

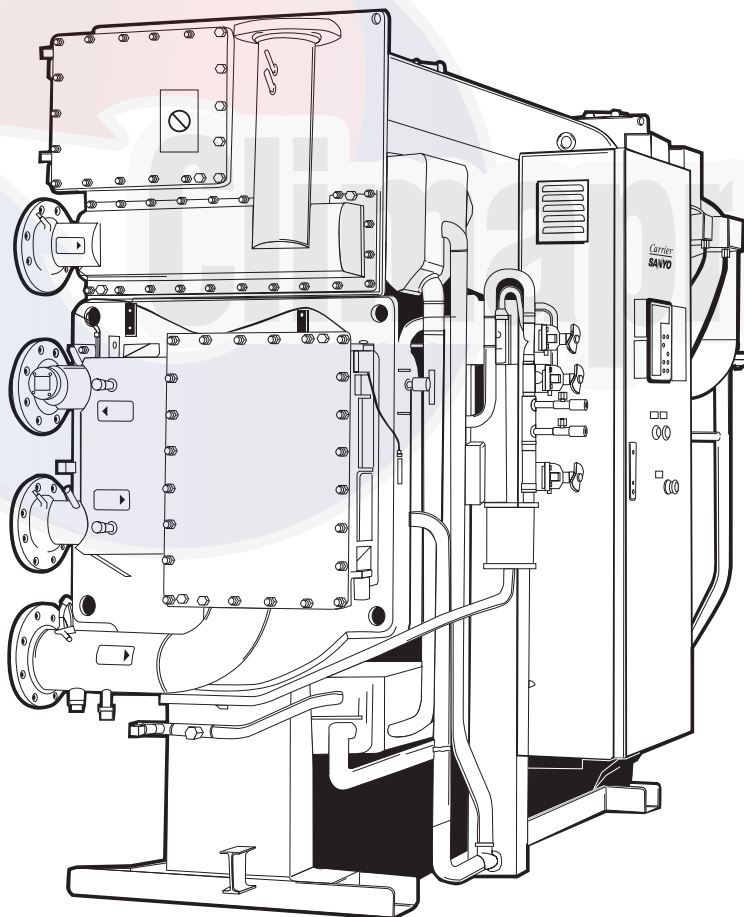

Product Data

16LJ Single-Effect, Low Temperature Hot Water Hermetic Absorption Liquid Chiller

75 to 525 Nominal Tons



Carrier
SANYO

Carrier-Sanyo's 16LJ single-effect hermetic absorption liquid chiller is an efficient and functional alternative to traditional electric driven chillers. The 16LJ absorption chiller uses low temperature hot water as its energy source; as it eliminates the need for high cost electricity, it may qualify for financial incentives as a gas cooling product. The 16LJ absorption chiller offers functional flexibility in a variety of installations:

- no CFCs; environmentally sound
- single stage design for simple, dependable operation
- high reliability with few moving parts
- nominal coefficient of performance (COP) of .70
- quiet, vibration-free operation
- Direct Digital Controls (DDC) for optimum chiller performance

Features/Benefits

Single-effect absorption cycle provides efficient, economical water chilling with minimal use of electricity.

Cost-effective cooling

Alternative-energy chiller — The 16LJ chiller is a solution for building owners who want to avoid high operating costs associated with electric-driven chillers. Powered by low temperature hot water, the Carrier-Sanyo 16LJ absorption chiller reduces or eliminates electric demand and/or ratchet charges while allowing the owner to take advantage of gas cooling incentives when offered by local utility companies.

Features/Benefits (cont)



Simple, reliable operation — The 16LJ chiller's single generator provides one stage of solution reconcentration, which makes the 16LJ chiller one of the most basic cycles currently available. The 16LJ chiller's simple design, in addition to its other quality features, equates to inherently high reliability. Few moving parts and simple, dependable operation reduce downtime, as well as service and maintenance costs.

Exceptional efficiency — The 16LJ chiller offers full-load COPs of .70 at standard ARI (Air Conditioning and Refrigeration Institute) operating conditions. The 16LJ chiller provides efficient performance for a low temperature hot water absorber. Incorporated into the standard machine design is a solution heat exchanger, intended to preheat the weak lithium bromide solution being pumped to the generator by precooling the strong solution from the generator.

Superior part-load performance — The concentration control system of the 16LJ chiller allows stable, part-load operation at cooling water temperatures as low as 64 F exclusive of the need for a cooling tower bypass. A control valve integral to the machine guarantees stable, continuous refrigerant pump operation at part-load conditions. The 16LJ chiller has a continuous operating range from 100% to 10% of rated machine capacity.

Application versatility

Designed for a variety of applications — Specifically designed for use with low temperature hot water, the 16LJ chiller can be applied to a variety of cooling needs. Waste heat from industrial processes and/or cogeneration systems can be used to provide chilled water for process cooling, as well as comfort cooling, thus reducing the need for additional energy and contributing to greater overall energy savings.

Ideal for new or retrofit applications — From replacement or expansion of existing chiller systems to new construction projects, the 16LJ chiller is capable of meeting the needs of almost any cooling application. Fifteen model sizes, with a capacity range of 75 to 525 tons, make the 16LJ single-effect absorption chiller the ultimate choice for comfort cooling and/or light industrial applications.

Computerized performance ratings allow the appropriately sized machine to be selected in order to meet exact job requirements. All machine selections are rated in accordance with the latest edition of ARI-560.

Combine absorption and electric-driven chillers — Utilizing both absorption and electric chillers in a central plant offers the flexibility to base load one chiller, while using the other to handle peak load requirements. Hybrid chiller systems have proven to be an economical solution for many chilled water plants. In many geographical areas, operating the electric chiller as the base loaded machine while using the absorption chiller during peak load conditions provides the most economical operating cost scenario. The reverse may also be true, depending on utility rate structures and other job specifics. Either way, a 16LJ single-effect absorption chiller used in conjunction with an electric-driven chiller may be the most efficient and cost-effective combination available.

Location and installation savings

Ease of installation — All machines are completely fabricated, assembled, wired and tested in the factory as single-piece units. Units are customarily shipped in one piece for all model sizes, but shipment in multiple sections is available, making the 16LJ chiller ideal for retrofit or replacement installations where equipment room access may be limited. Re-assembly of the chiller at the jobsite, if required, is both straightforward and simple due to special provisions made to the

machine during the factory fabrication and sectioning process.

Small footprint — Compared to other single-effect chillers, the 16LJ chiller is significantly smaller in overall physical size and weight, saving valuable space in the equipment room as well as reducing the rigging and installation cost of the machine.

Flanged waterbox nozzles — All 16LJ chillers incorporate ANSI (American National Standards Institute) raised face flanges as standard on all external piping connections, simplifying chiller installation and field piping.

Low sound and vibration levels allow location flexibility — Absorption chillers are distinguishable by their low sound and vibration levels, primarily because the only rotating parts are the refrigerant and absorbent pumps. The overall sound level of the Carrier-Sanyo 16LJ chiller is typically 80 dbA, therefore the machine may easily be installed near occupied spaces or in areas with strict sound requirements. Low vibration levels also make it possible to install the chiller on upper floors without special consideration for vibration dampening systems.

Microprocessor control features/benefits

Each 16LJ single-effect chiller includes a pre-programmed, factory-mounted and factory-wired control panel, which is functionally tested prior to shipment. Chiller monitoring and control is automatic and continuous, and the screen on the front panel displays chiller operational status and fault indications in English or metric units.

Table of contents

	Page
Features/Benefits	1-5
Model Number Nomenclature	6
Options and Accessories	6
Machine Components	7
Physical Data	8
Dimensions	9-16
Performance Data	17
Application Data	18-20
Electrical Data	21
Controls	22-24
Typical Piping	25
Guide Specifications	26-30



The Carrier-Sanyo microprocessor PID (proportional, integral, derivative) control system surpasses proportional only control systems by maintaining precise leaving chilled water temperature versus actual set point. The PID controls surpass proportional only controls in their ability to control the machine and narrow temperature variations. The 16LJ chiller control system also incorporates the ability to control the chilled water and cooling water pumps automatically. During shutdown these pumps are sequenced to ensure a complete dilution cycle, thus providing protection from solution crystallization.

Leaving chilled water temperature is measured every 5 seconds by the control system. Hot water input to the generator is then adjusted according to the degree of deviation of actual leaving chilled water temperature versus set point. System temperatures, set points and operational records are displayed on the front of the panel along with various indicator lights that represent chiller operational status. A purge status light on the panel indicates when noncondensables need to be exhausted from the external purge storage chamber via the purge pump.

The Carrier-Sanyo 16LJ chiller's control system automatically performs self-diagnostic checks by constantly monitoring the chiller's operational status and will automatically shut down the machine if a fault occurs. The cause of shut down will be retained in the controller's memory and can be displayed for immediate operator review. The controller's memory will also retain and display the cause of the last three system fault conditions, which is extremely useful for maintaining an accurate record of unit performance and fault history.

Local or remote operation of the 16LJ chiller can be done by configuration of the controls during initial setup.

Single point electrical connection — Installation costs are reduced by eliminating the need for field wiring between machine components. All electrical items, including the unit-mounted purge pump, are factory-wired to the chiller control center and require a single point electrical connection to the machine from the building's electrical service. A control power transformer mounted in the chiller panel provides secondary single-phase control power.

Low maintenance

Durable machine construction — Each Carrier-Sanyo 16LJ chiller is constructed to meet rigorous manufacturing and design requirements in an ISO-9002 and ISO-14001 certified facility. Furthermore, every machine meets strict Underwriters' Laboratories (UL) certification requirements and is UL listed. The 16LJ chiller offers numerous features as part of its standard design to provide dependable operation. Corrosion-proof stainless steel dispersion trays ensure continuous, reliable operation, free from blockage often characteristic of alternative designs. The evaporator, absorber and condenser tubesheets and waterboxes are epoxy painted to resist rust and corrosion. Also, every machine is furnished with a rupture disk to protect against an overpressure condition on the shellside. These standard design and construction features mean that every 16LJ single-effect chiller is built to withstand the most rigorous duty, whether applied for comfort cooling service or light process applications.

Leakproof hermetic pumps with isolation valves cut maintenance costs — The 16LJ chiller's absorbent and refrigerant pump/motor assemblies have a leakproof, self-contained and hermetically sealed design. The hermetic construction eliminates the need for a separate, complicated, and possibly leakprone seal water system and auxiliary water piping, while providing leak tightness and longer machine life. Specially designed bearings absorb both radial and axial thrusts to ensure correct fit at all times. Concerns about external contamination are eliminated since the fluid being pumped lubricates and cools the pump and motor assemblies. In addition, both the rotor and stator are separated by a stainless steel liner that protects the windings from the fluid being handled. Thermal overload switches are embedded in the stator as an additional safety feature. This feature protects against high winding temperature. The pumps are field serviceable and inspection is recommended after 25,000 hours or 3 years of continuous operation. Isolation valves, a standard feature on the suction and discharge of the absorbent and refrigerant pumps, allow easy access for service and maintenance.

Waterbox design simplifies maintenance procedures — Every 16LJ chiller is provided with numerous standard design features that permit convenient and simple maintenance to be carried out quickly. Hinged or removable waterbox covers on the evaporator, absorber, and condenser facilitate tube and waterbox inspection and/or cleaning from either end of the machine. In addition, the absorber and condenser sections are furnished as standard with marine waterboxes for easy access without having to disassemble water piping.

Factory-trained service organization — In addition to routine maintenance and repair services, Carrier also offers a wide array of preventative maintenance, full maintenance, and/or extended service contracts which can be custom-tailored to fulfill any service requirements. Carrier's extensive service organization offers trained and experienced service technicians in every major city.

Superior corrosion protection — All absorption chillers must be protected from the corrosion that occurs on internal machine surfaces when in contact with lithium bromide solution. The 16LJ absorption chiller includes an extremely effective corrosion inhibitor to provide an extra margin of protection against internal corrosion. Other inhibitors may need exotic tube materials in certain heat exchangers as they are less effective and require more frequent maintenance and analysis. The superior corrosion protection of the Carrier-Sanyo inhibitor allows the use of standard copper tubes throughout the machine, which results in long machine life and dependable operation.

Automatic purge extends machine life, ensures optimum efficiency and performance

The purge system on an absorption chiller is essential to ensuring long machine life and efficient operation. All absorption chillers operate in a vacuum and generate hydrogen (and other noncondensable gases) in small quantities, even when they are vacuum tight and properly inhibited. If not properly controlled, these gases can interfere with machine operation, therefore it is imperative that they be removed to protect against internal

Features/Benefits (cont)



corrosion, lithium bromide solution crystallization, and/or reduction of chiller capacity. The Carrier-Sanyo purge system protects against these potential hazards by operating continuously during machine operation.

How the purge system operates —

During chiller operation, any noncondensables that are present tend to accumulate in the absorber section, which operates at the lowest pressure internal to the machine. A slipstream of lithium bromide solution flows through an eductor from the absorbent pump discharge. This process creates suction, which draws the noncondensables from the absorber, entraining them with the solution flowing through the eductor. The eductor discharges the solution and noncondensables into the purge tank, where the noncondensables are separated from the solution. The noncondensables remain in the purge tank while the lithium bromide solution returns to the absorber sump. As noncondensables accumulate in the external purge tank, they are isolated from the chiller and cannot re-enter the chiller even during shutdown. A heated palladium cell connected to the storage chamber aids in elimination of hydrogen from the purge tank at all times. A unit-mounted purge pump further aids in removing noncondensables from the purge tank, when necessary.

Anticrystallization controls maintain proper solution concentration

— The 16LJ chiller automatically limits solution concentration in several ways to avoid both crystallization and overdilution to provide dependable, trouble-free operation. Crystallization of the lithium

bromide solution depends on the combination of temperature and concentration. The Carrier-Sanyo concentration control system automatically monitors solution concentration by continuously sensing the temperature of the strong solution and the refrigerant condensation temperature. From this data, the microprocessor controls are able to determine the solution concentration and automatically limit the heat input to the chiller, if necessary, to prevent an overconcentration condition from occurring. Constant monitoring of the cycle ensures continuous, reliable operation even at cooling water temperatures as low as 64 F. Upon shutdown, the chiller dilution cycle is automatically controlled to an optimized period ranging from 6 to 15 minutes by the microprocessor controls in conjunction with the generator solution temperature. This optimized dilution operation period enables energy savings of the onboard chiller pumps as well as the chilled water and cooling water pumps. The dilution cycle also minimizes the time required for chiller start-up by preventing overdilution of the solution.

16LJ single-effect absorption cooling cycle

The 16LJ single-effect absorption chiller is comprised of an evaporator, absorber, condenser, hot water generator, solution heat exchanger, refrigerant/absorbent pumps, purge, controls, and auxiliaries. Water is used as the refrigerant in vessels maintained under low absolute pressure (vacuum).

The chiller operates on the principle that under vacuum, water boils at a low

temperature (approximately 40 F), thereby cooling the chilled water circulating through the tubes of the evaporator. A refrigerant pump is used to circulate the refrigerant water over the evaporator tubes to enhance the heat transfer process. The refrigerant vapor is removed as it is produced in order to make the cooling process continuous. A lithium bromide solution (which has a high affinity for water) is used to absorb the water vapor. As this process continues, the lithium bromide becomes diluted, which reduces its absorption ability. An absorbent pump then transfers this weak (diluted) solution to the generator, where it is reconcentrated by the introduction of hot water in the tubes of the generator to boil off the previously absorbed water. The water vapor released on the shellside of the generator enters the condenser to be cooled and returned to a liquid state. At this point, the refrigerant water returns to the evaporator to begin a new cycle. To remove heat from the machine, relatively cool water from a cooling tower or other source is circulated through the tubes of the absorber to remove the heat of vaporization. This same water is then circulated through the tubes of the condenser. The strong (reconcentrated) solution from the generator flows back to the absorber to begin a new cycle. For efficiency, the strong solution from the generator is passed through a solution heat exchanger to preheat the weak solution while precooling the strong solution before returning to the absorber.

16LJ ABSORPTION CHILLER COOLING CYCLE

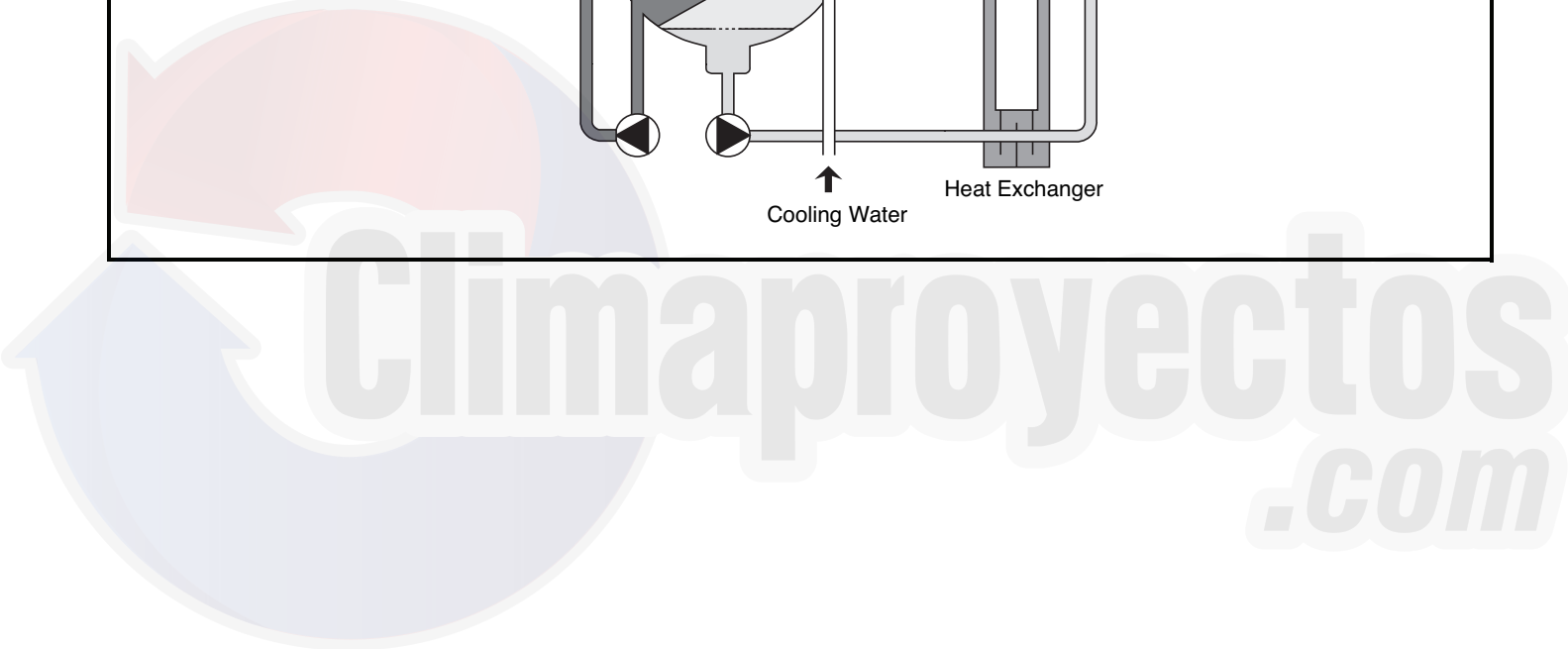
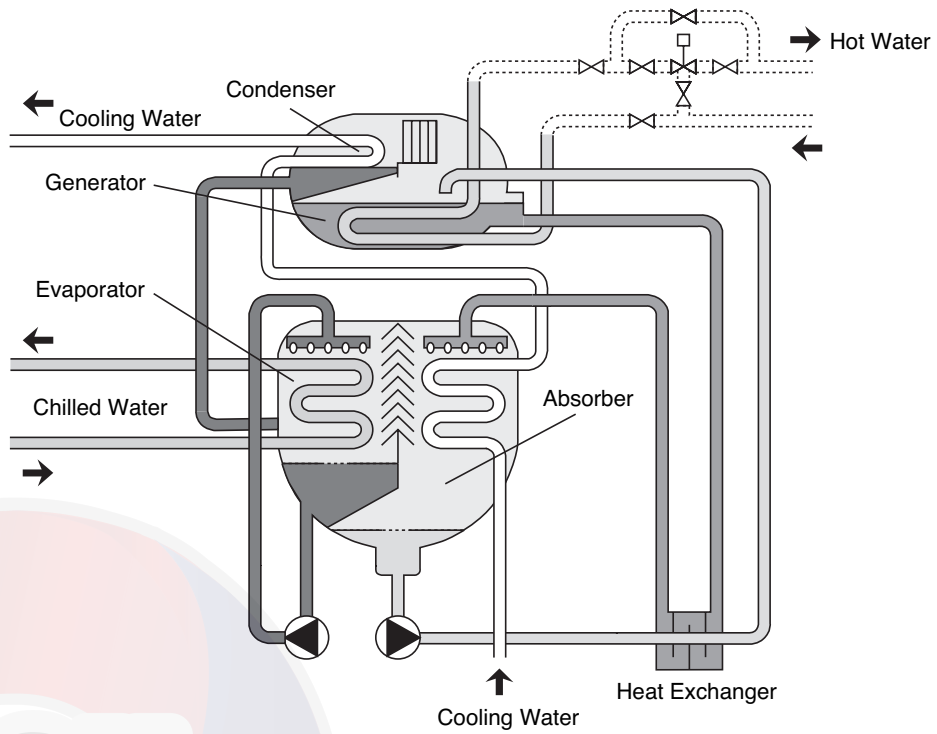

Model number nomenclature

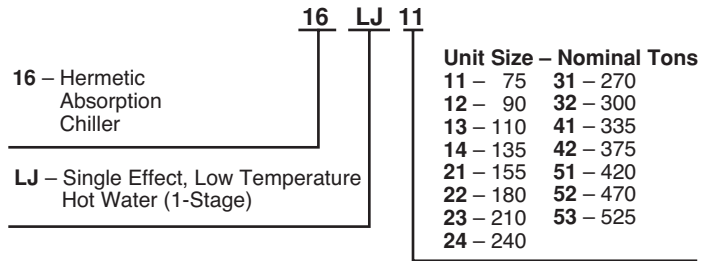

→ Options and accessories

ITEM	FACTORY-INSTALLED OPTION	FIELD-INSTALLED ACCESSORY
Cooling Water Flow Switch	X	
High-Pressure Waterboxes, 300 psig	X	
Hot Water Control Valve		X
Isolation Package		X
Marine Waterboxes	X	
Shipping Configuration (1-piece or 2-piece)	X	
Special Tubing	X	
Victaulic Nozzle Connections	X	
Thermometer Set		X

Machine components

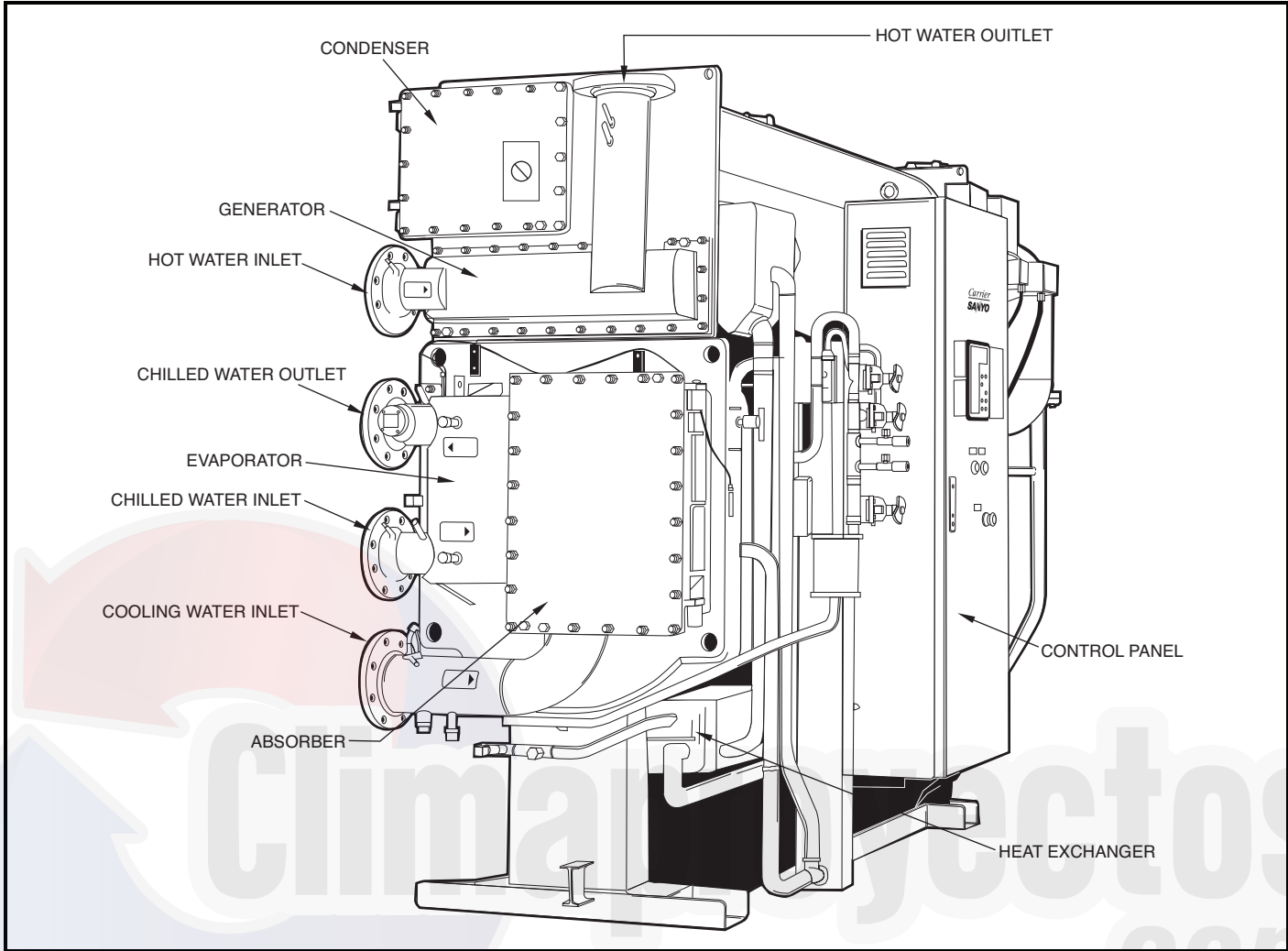

Physical data



UNIT 16LJ	11	12	13	14	21
NOMINAL COOLING CAPACITY (ton)	75	90	110	135	155
RIGGING WEIGHT (lb)	7,800	8,000	10,000	10,400	12,600
OPERATING WEIGHT (lb)	8,900	9,300	11,500	12,200	14,800
LITHIUM BROMIDE SOLUTION CHARGE (lb)	950	950	1,240	1,370	1,660
REFRIGERANT (WATER) CHARGE (lb)	130	130	220	200	240
CHILLED WATER					
Pipe Connection Size (in.)	3	3	4	4	5
No. of Passes	5	5	3	3	3
COOLING WATER					
Pipe Connection Size (in.)	5	5	5	5	6
No. of Passes					
Absorber	4	4	4	4	4
Condenser	2	2	2	2	2
HOT WATER					
Pipe Connection Size (in.)	4	4	4	4	5
No. of Passes	6	4	4	4	4

UNIT 16LJ	22	23	24	31	32
NOMINAL COOLING CAPACITY (ton)	180	210	240	270	300
RIGGING WEIGHT (lb)	13,300	15,500	16,100	19,900	20,800
OPERATING WEIGHT (lb)	15,700	18,100	19,200	23,400	24,500
LITHIUM BROMIDE SOLUTION CHARGE (lb)	1,790	2,170	2,360	2,720	2,960
REFRIGERANT (WATER) CHARGE (lb)	260	330	310	420	370
CHILLED WATER					
Pipe Connection Size (in.)	5	5	5	6	6
No. of Passes	3	3	3	3	3
COOLING WATER					
Pipe Connection Size (in.)	6	8	8	8	8
No. of Passes					
Absorber	4	2	2	2	2
Condenser	2	2	2	2	2
HOT WATER					
Pipe Connection Size (in.)	5	6	6	6	6
No. of Passes	4	3	3	3	3

UNIT 16LJ	41	42	51	52	53
NOMINAL COOLING CAPACITY (ton)	335	375	420	470	525
RIGGING WEIGHT (lb)	23,900	24,700	33,300	36,200	38,900
OPERATING WEIGHT (lb)	28,500	29,600	40,200	43,500	46,600
LITHIUM BROMIDE SOLUTION CHARGE (lb)	3,440	3,710	4,300	4,790	5,340
REFRIGERANT (WATER) CHARGE (lb)	550	510	570	640	680
CHILLED WATER					
Pipe Connection Size (in.)	8	8	8	8	8
No. of Passes	3	3	3	2	2
COOLING WATER					
Pipe Connection Size (in.)	10	10	12	12	12
No. of Passes					
Absorber	2	2	4	2	2
Condenser	2	2	2	2	2
HOT WATER					
Pipe Connection Size (in.)	8	8	8	8	8
No. of Passes	3	3	3	3	3

Dimensions



16LJ11 AND 16LJ12

- LEGEND**
- ANSI — American National Standards Institute
 - CHW — Chilled Water
 - COW — Cooling Water
 - HTW — Hot Water

NOTES:

1. Dimensions are shown in inches.
2. Dimensions (L), (W), (H) are for standard machine.
3. indicates the position of anchor bolts.
4. For routine maintenance allow 3 ft clearance on all sides and 8 in. above chiller.
5. For tube removal clearance, refer to drawing.
6. Standard water piping connections are ANSI 150 lb flanges.
7. Pass quantity and nozzle locations are for standard machine; other configurations are available.

UNIT 16LJ	A (in.)
11	4 1/4
12	5

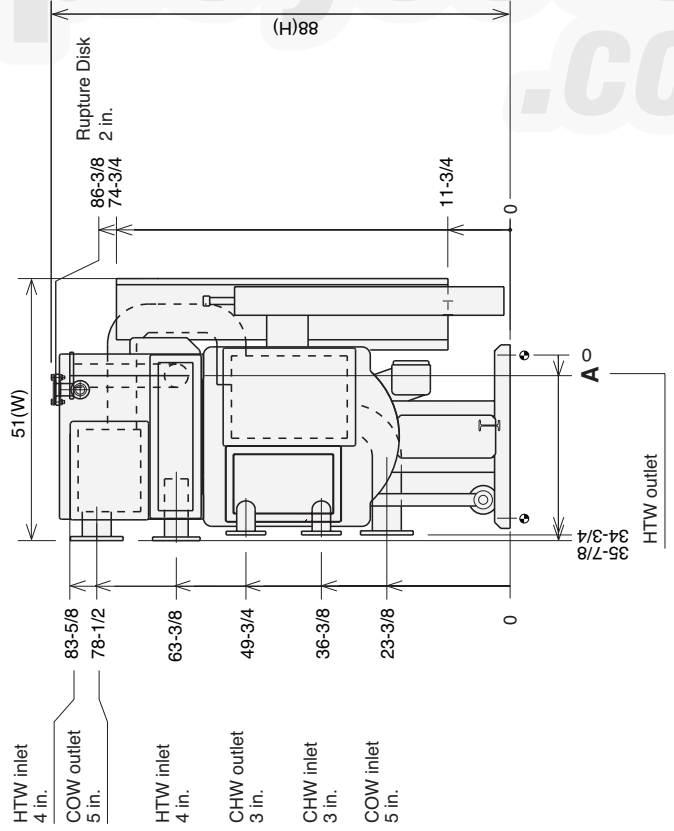
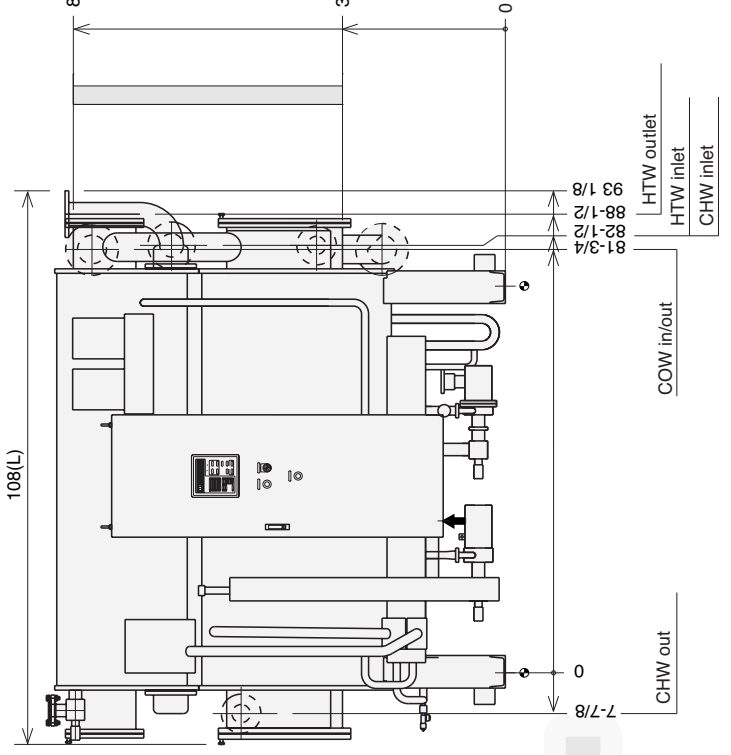
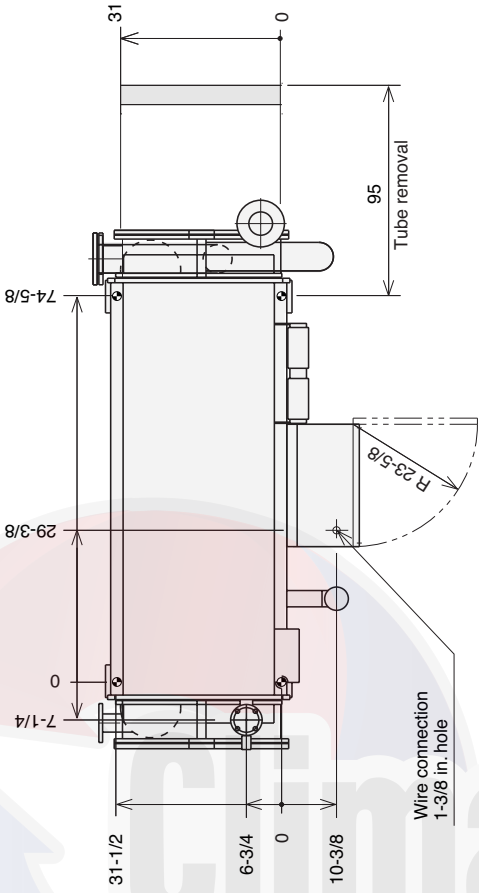

Dimensions (cont)



16LJ13 AND 16LJ14

- LEGEND**
- ANSI — American National Standards Institute
 - CHW — Chilled Water
 - COW — Cooling Water
 - HTW — Hot Water

NOTES:

1. Dimensions are shown in inches.
2. Dimensions (L), (W), (H) are for standard machine.
3.  indicates the position of anchor bolts.
4. For routine maintenance allow 3 ft clearance on all sides and 8 in. above chiller.
5. For tube removal clearance, refer to drawing.
6. Standard water piping connections are ANSI 150 lb flanges.
7. Pass quantity and nozzle locations are for standard machine; other configurations are available.

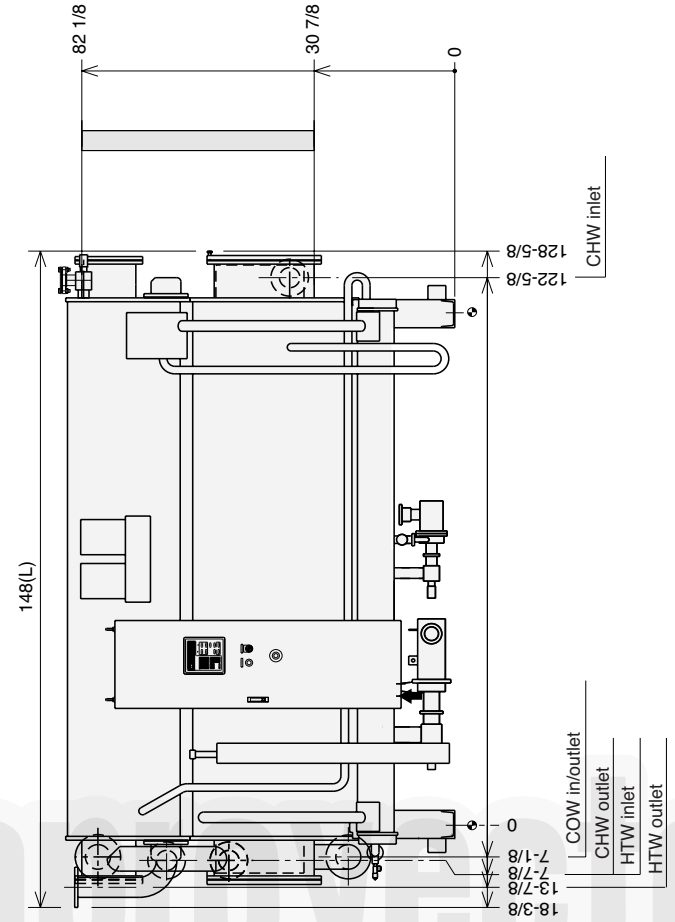
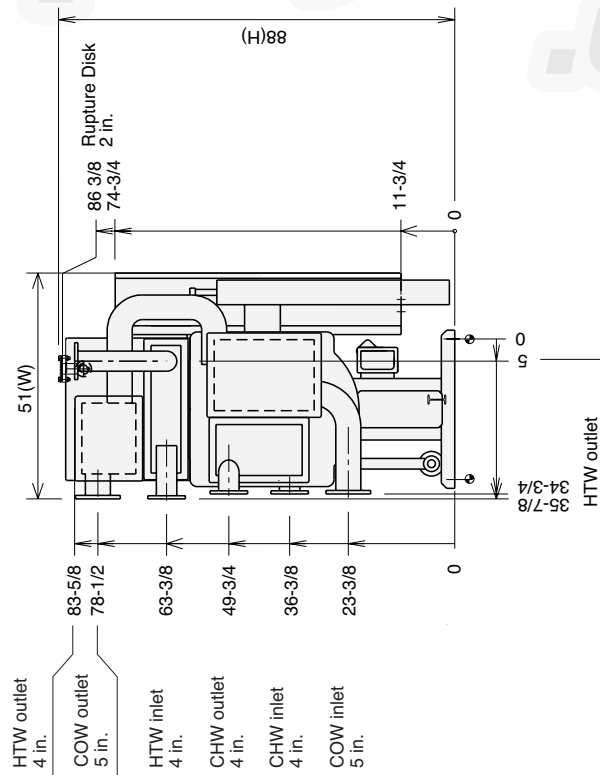
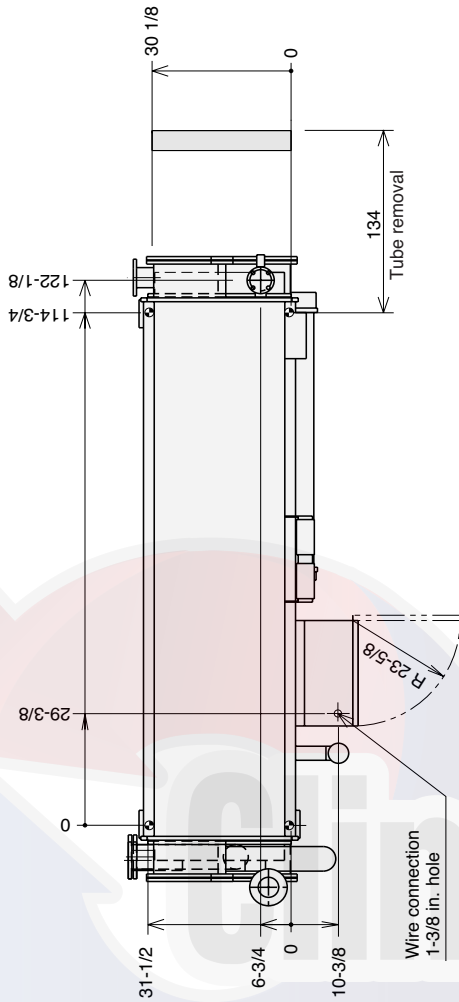

16LJ21 AND 16LJ22

- LEGEND**
- ANSI — American National Standards Institute
 - CHW — Chilled Water
 - COW — Cooling Water
 - HTW — Hot Water

- NOTES:**
1. Dimensions are shown in inches.
 2. Dimensions (L), (W), (H) are for standard machine.
 3. indicates the position of anchor bolts.
 4. For routine maintenance allow 3 ft clearance on all sides and 8 in. above chiller.
 5. For tube removal clearance, refer to drawing.
 6. Standard water piping connections are ANSI 150 lb flanges.
 7. Pass quantity and nozzle locations are for standard machine; other configurations are available.

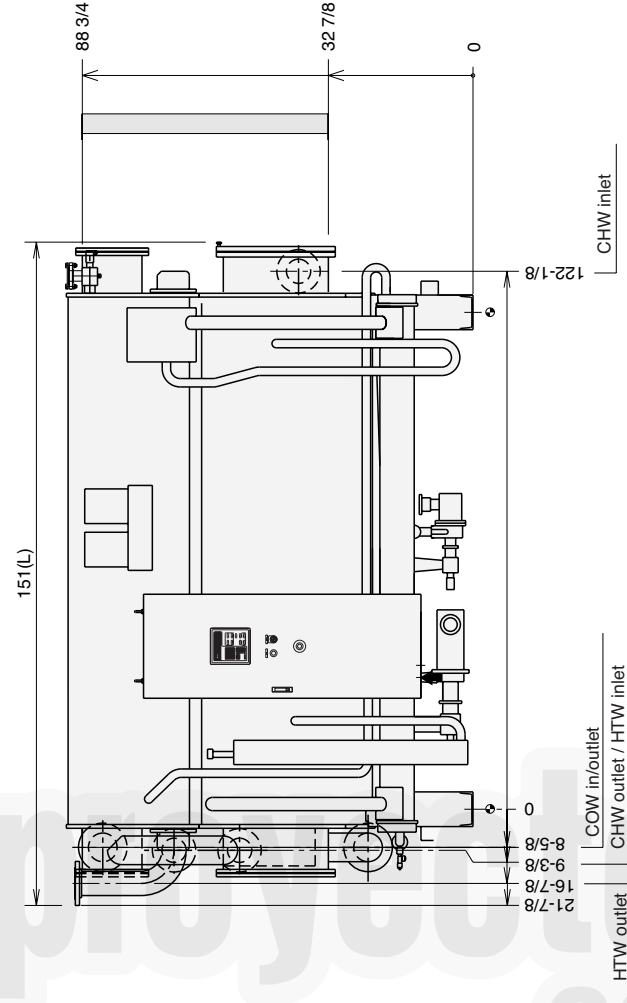
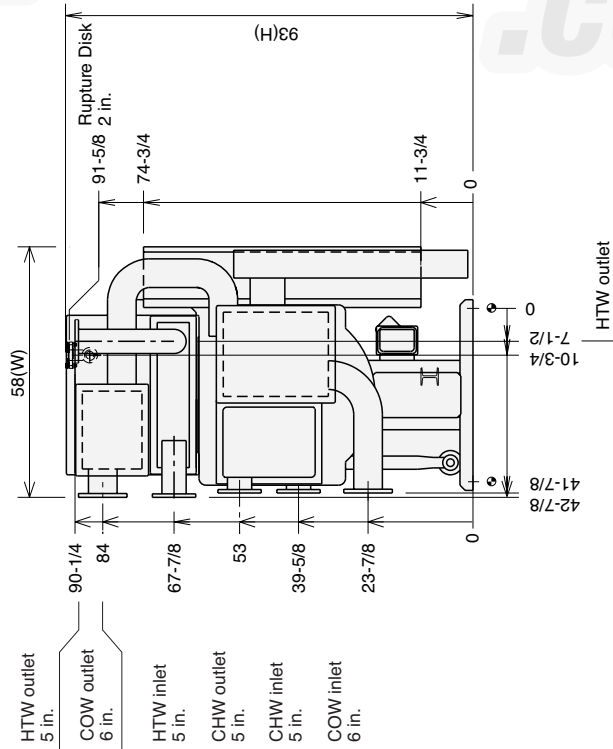
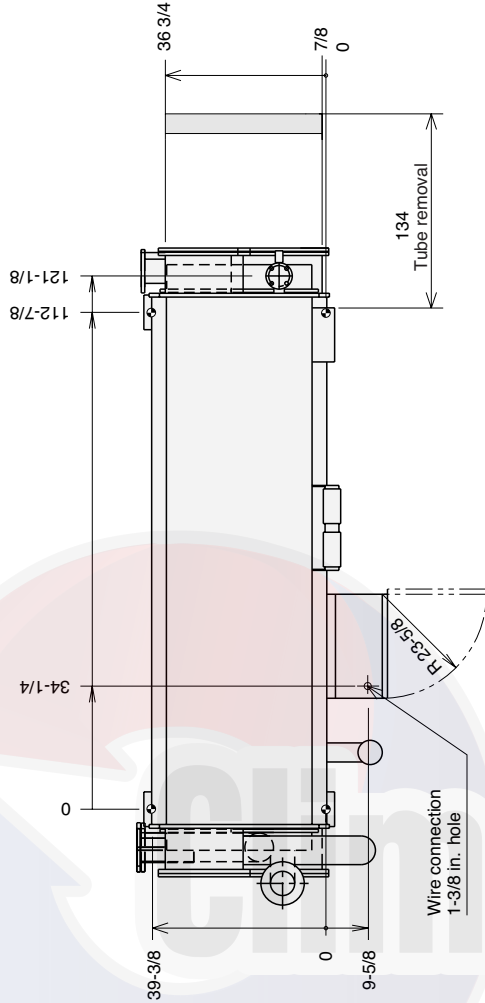

Dimensions (cont)



16LJ23 AND 16LJ24

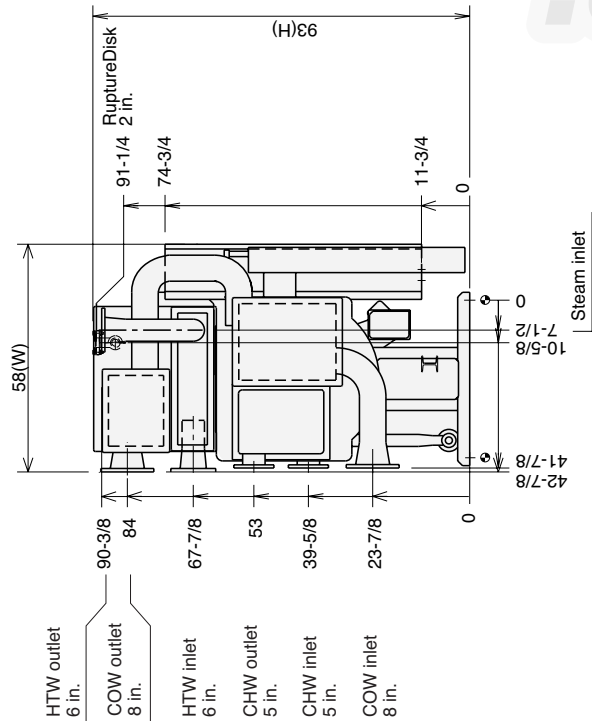
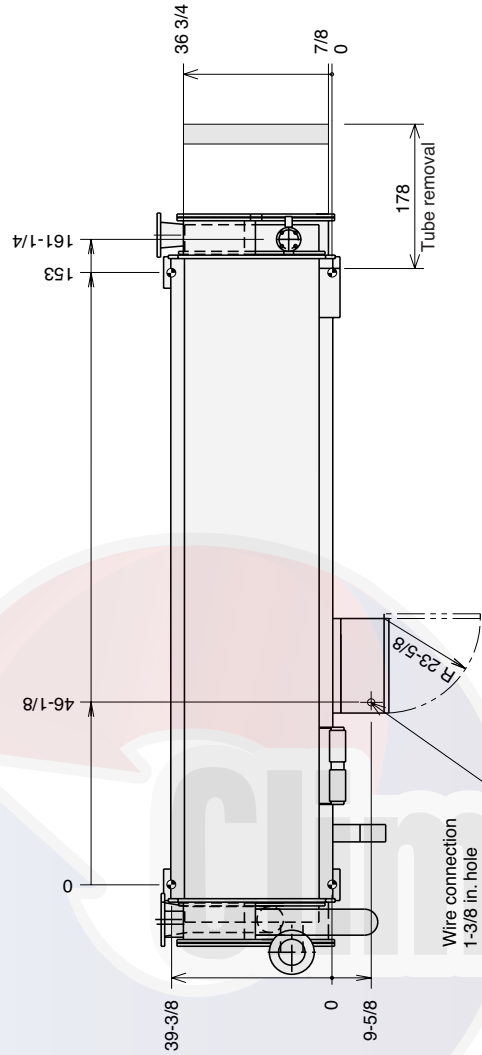

LEGEND

- ANSI** — American National Standards Institute
- CHW** — Chilled Water
- COW** — Cooling Water
- HTW** — Hot Water

NOTES:

1. Dimensions are shown in inches.
2. Dimensions (L), (W), (H) are for standard machine.
3. indicates the position of anchor bolts.
4. For routine maintenance allow 3 ft clearance on all sides and 8 in. above chiller.
5. For tube removal clearance, refer to drawing.
6. Standard water piping connections are ANSI 150 lb flanges.
7. Pass quantity and nozzle locations are for standard machine; other configurations are available.

Dimensions (cont)



16LJ41 AND 16LJ42

- LEGEND**
- ANSI — American National Standards Institute
 - CHW — Chilled Water
 - COW — Cooling Water
 - HTW — Hot Water

NOTES:

1. Dimensions are shown in inches.
2. Dimensions (L), (W), (H) are for standard machine.
3.  indicates the position of anchor bolts.
4. For routine maintenance allow 3 ft clearance on all sides and 8 in. above chiller.
5. For tube removal clearance, refer to drawing.
6. Standard water piping connections are ANSI 150 lb flanges.
7. Pass quantity and nozzle locations are for standard machine; other configurations are available.

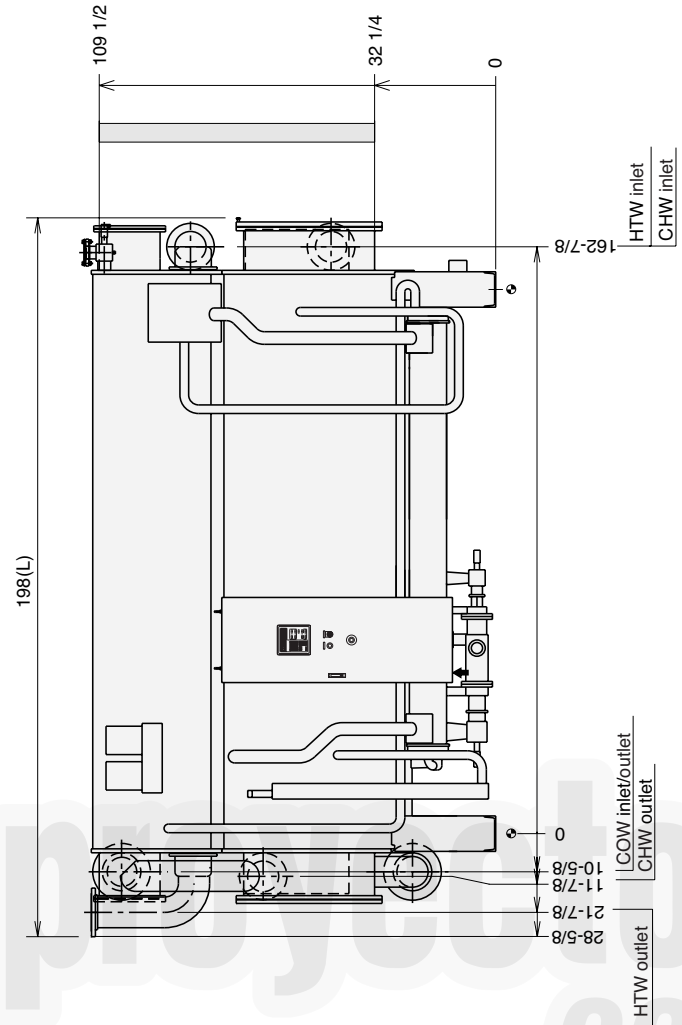
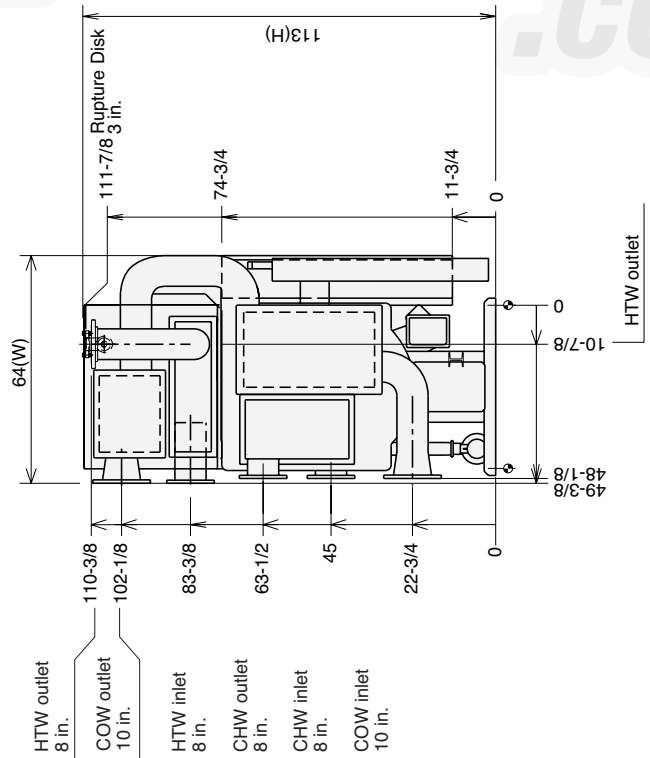
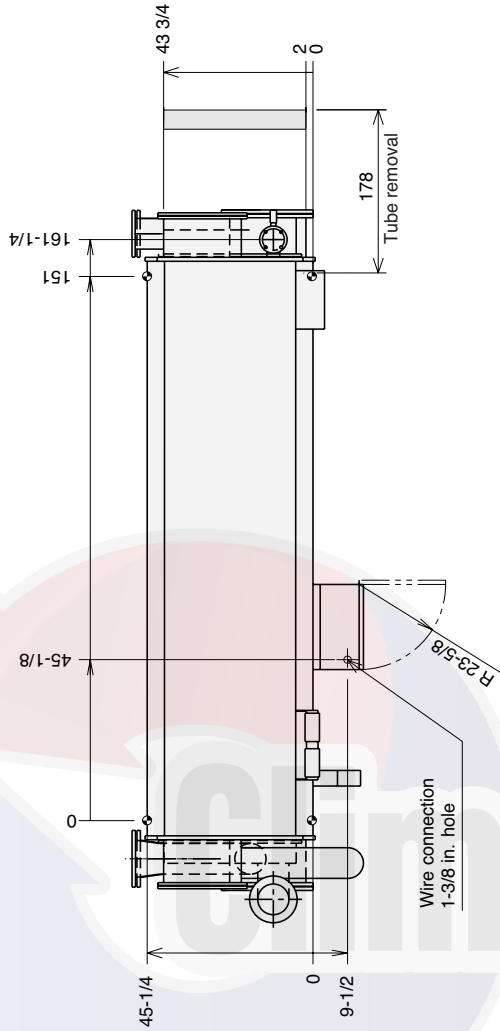

16LJ51-53

- LEGEND**
- ANSI — American National Standards Institute
 - CHW — Chilled Water
 - COW — Cooling Water
 - HTW — Hot Water

- NOTES:**
- Dimensions are shown in inches.
 - Dimensions (L), (W), (H) are for standard machine.
 - ⊙ indicates the position of anchor bolts.
 - For routine maintenance allow 3 ft clearance on all sides and 8 in. above chiller.
 - For tube removal clearance, refer to drawing.
 - Standard water piping connections are ANSI 150 lb flanges.
 - Pass quantity and nozzle locations are for standard machine; other configurations are available.

UNIT	A	B	C	D	E	F	K	L
16LJ								
51	145 ¹ / ₈	151	158 ³ / ₄	166 ¹ / ₂	33 ¹ / ₂	160 ⁵ / ₈	182	205
52	167 ¹ / ₄	172 ³ / ₈	180	187 ⁷ / ₈	33 ¹ / ₂	182	205	226
53	186 ⁷ / ₈	192	199 ⁵ / ₈	207 ¹ / ₂	33 ¹ / ₂	201 ⁵ / ₈	225	246

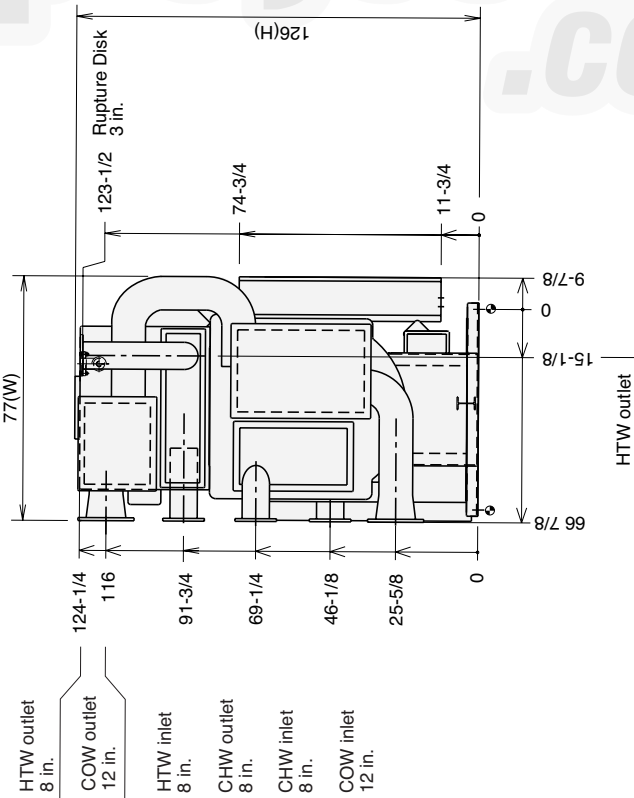
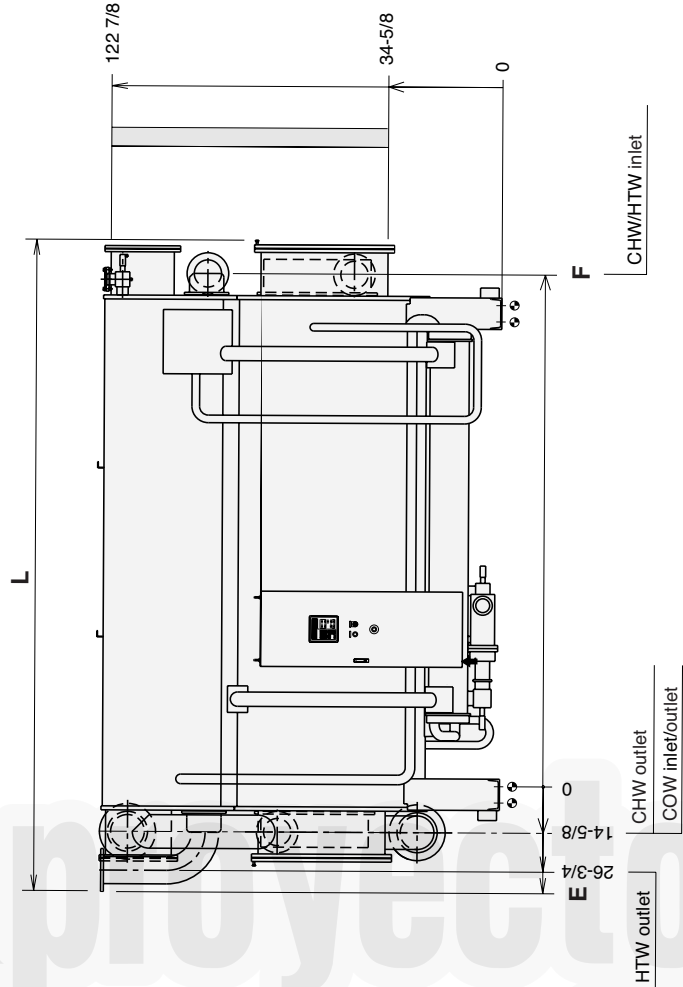
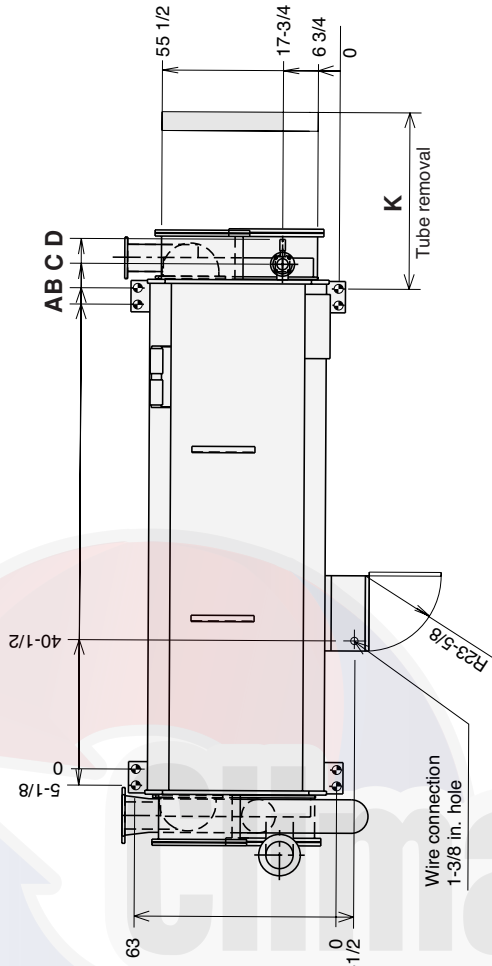

Dimensions (cont)



FOUNDATION

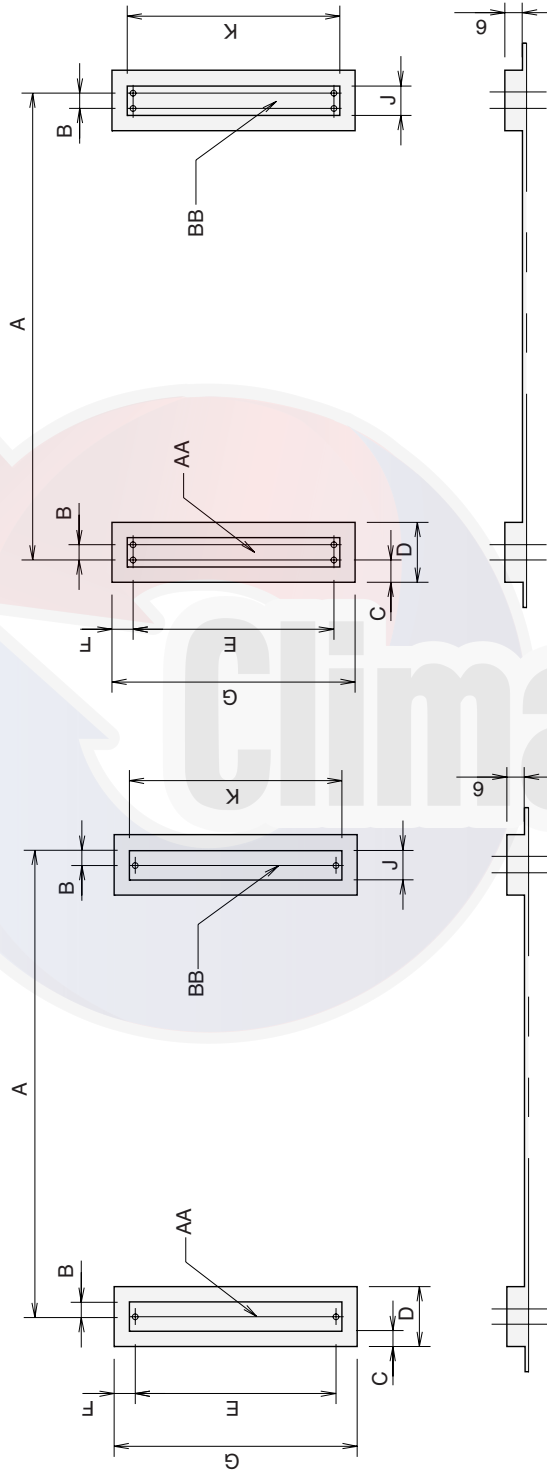

16LJ11-42

16LJ51-53

UNIT 16LJ	WEIGHT (lb)		DIMENSIONS (in.)										
	AA	BB	A	B	C	D	E	F	G	J	K		
11	4,450	4,450	74 ⁵ / ₈	7 ¹ / ₄	3 ⁷ / ₈	14 ¹ / ₈	31 ¹ / ₂	5 ⁷ / ₈	43 ¹ / ₄	6 ¹ / ₄	35 ³ / ₈		
12	4,650	4,650	74 ⁵ / ₈	7 ¹ / ₄	3 ⁷ / ₈	14 ¹ / ₈	31 ¹ / ₂	5 ⁷ / ₈	43 ¹ / ₄	6 ¹ / ₄	35 ³ / ₈		
13	5,750	5,750	114 ³ / ₄	7 ¹ / ₄	3 ⁷ / ₈	14 ¹ / ₈	31 ¹ / ₂	5 ⁷ / ₈	43 ¹ / ₄	6 ¹ / ₄	35 ³ / ₈		
14	6,100	6,100	114 ³ / ₄	7 ¹ / ₄	3 ⁷ / ₈	14 ¹ / ₈	31 ¹ / ₂	5 ⁷ / ₈	43 ¹ / ₄	6 ¹ / ₄	35 ³ / ₈		
21	7,400	7,400	112 ⁷ / ₈	7 ⁷ / ₈	3 ⁷ / ₈	15 ³ / ₄	39 ³ / ₈	5 ⁷ / ₈	51 ¹ / ₈	7 ⁷ / ₈	43 ¹ / ₄		
22	7,850	7,850	112 ⁷ / ₈	7 ⁷ / ₈	3 ⁷ / ₈	15 ³ / ₄	39 ³ / ₈	5 ⁷ / ₈	51 ¹ / ₈	7 ⁷ / ₈	43 ¹ / ₄		
23	9,050	9,050	153	7 ⁷ / ₈	3 ⁷ / ₈	15 ³ / ₄	39 ³ / ₈	5 ⁷ / ₈	51 ¹ / ₈	7 ⁷ / ₈	43 ¹ / ₄		
24	9,600	9,600	153	7 ⁷ / ₈	3 ⁷ / ₈	15 ³ / ₄	39 ³ / ₈	5 ⁷ / ₈	51 ¹ / ₈	7 ⁷ / ₈	43 ¹ / ₄		
31	11,700	11,700	151	8 ⁷ / ₈	3 ⁷ / ₈	17 ³ / ₄	43 ¹ / ₄	5 ⁷ / ₈	55 ¹ / ₈	9 ⁷ / ₈	47 ¹ / ₄		
32	12,250	12,250	151	8 ⁷ / ₈	3 ⁷ / ₈	17 ³ / ₄	43 ¹ / ₄	5 ⁷ / ₈	55 ¹ / ₈	9 ⁷ / ₈	47 ¹ / ₄		
41	14,250	14,250	151	8 ⁷ / ₈	3 ⁷ / ₈	17 ³ / ₄	45 ¹ / ₄	5 ⁷ / ₈	57 ¹ / ₈	9 ⁷ / ₈	49 ¹ / ₄		
42	14,800	14,800	151	8 ⁷ / ₈	3 ⁷ / ₈	17 ³ / ₄	45 ¹ / ₄	5 ⁷ / ₈	57 ¹ / ₈	9 ⁷ / ₈	49 ¹ / ₄		
51	20,100	20,100	145 ⁷ / ₈	5 ¹ / ₈	7 ¹ / ₂	20 ¹ / ₈	63	7 ¹ / ₈	77 ¹ / ₈	9 ⁷ / ₈	66 ⁷ / ₈		
52	21,750	21,750	167 ¹ / ₄	5 ¹ / ₈	7 ¹ / ₂	20 ¹ / ₈	63	7 ¹ / ₈	77 ¹ / ₈	9 ⁷ / ₈	66 ⁷ / ₈		
53	23,300	23,300	186 ⁷ / ₈	5 ¹ / ₈	7 ¹ / ₂	20 ¹ / ₈	63	7 ¹ / ₈	77 ¹ / ₈	9 ⁷ / ₈	66 ⁷ / ₈		

- NOTES:
- Dimensions are shown in inches.
 - The base of the machine has 2-in. diameter hole for anchor bolt.
 - Anchor bolts should be fixed as shown in detailed foundation drawings. Washer should be welded to base.
 - Drain ditch around the foundation is required.
 - Surface of foundation should be flat within $\pm 1/4$ in. per 20 ft.
 - Anchor bolts, washers and nuts are supplied by customer.

Performance data



UNIT 16LJ	11	12	13	14	21	22	23	24
COOLING CAPACITY (Ton)	75	90	110	135	155	180	210	240
CHILLED WATER								
Flow Rate (gpm)	180	216	264	324	372	432	504	576
Pressure Drop (ft)	18.3	20.1	11.9	13.1	11.7	12.3	24.8	26.5
COOLING WATER								
Flow Rate (gpm)	270	324	396	486	558	648	756	864
Pressure Drop (ft)	12.2	12.9	21.8	26.1	36.0	23.4	34.5	35.3
HOT WATER								
Flow Rate (gpm)	164	197	241	296	339	394	460	526
Pressure Drop (ft)	10.3	4.0	9.9	10.8	10.1	10.1	9.9	10.1

UNIT 16LJ	31	32	41	42	51	52	53
COOLING CAPACITY (Ton)	270	300	335	375	420	470	525
CHILLED WATER							
Flow Rate (gpm)	648	720	804	900	1008	1128	1260
Pressure Drop (ft)	25.4	26.9	25.1	25.0	20.6	10.8	14.1
COOLING WATER							
Flow Rate (gpm)	972	1080	1206	1350	1512	1692	1890
Pressure Drop (ft)	32.4	32.9	33.0	34.3	31.3	29.4	39.1
HOT WATER							
Flow Rate (gpm)	591	657	734	821	920	1029	1150
Pressure Drop (ft)	9.7	9.6	9.4	9.5	9.3	12.4	16.3

NOTE: Ratings are based on ARI 560-2000:
 44 F chilled water, 2.4 gpm/ton, .0001 ft²-hr-F/Btu fouling factor
 85 F cooling water, 3.6 gpm/ton, .00025 ft²-hr-F/Btu fouling factor
 203 F hot water, 2.19 gpm/ton, .0001 ft²-hr-F/Btu fouling factor

Part-load performance

Part-load performance energy requirements for the 16LJ chiller, ranging from 10% to 100% of full load, can be obtained by contacting a local sales office.

All performance data is rated in accordance with ARI 560, latest edition, which defines Integrated Part Load Value (IPLV) as a measure of part-load efficiency representing the weighted average of overall chiller performance calculated by the following equation:

$$IPLV = .01A + .42B + .45C + .12D \text{ where}$$

- A = COP (Coefficient of Performance) at 100%
- B = COP at 75%
- C = COP at 50%
- D = COP at 25% or minimum load

Application data



DESIGN AND TEST PRESSURES

UNIT 16LJ	RUPTURE DISK SIZE	PIPING CONNECTION SIZE
11-24	2 in.	2 in. 150 psig RF flange
31-53	3 in.	3 in. 150 psig RF flange

LEGEND

RF — Raised Face

Range of application

The 16LJ single-effect hot water absorption chiller is designed for standard water chilling applications of 75 to 525 tons at standard ARI rating conditions. In most applications, the minimum leaving chilled water temperature is limited to 41 F. The minimum continuous inlet water temperature to the absorber-condenser circuit is 64 F, although lower temperatures are permitted during machine start-up. Use of a cooling tower bypass is required if water temperatures are anticipated to be less than this value.

UL certification

All 16LJ chillers have met the necessary design and construction qualifications for certification per Underwriters' Laboratories. Each machine carries a UL listing and is labeled accordingly.

Vent and drain connections

Vent and drain connections are found on each waterbox. Provide a vent on the high points of all water piping and a drain on all low points. If shutoff valves are provided in the main water piping close to the chiller, some system water will be lost when the heat exchangers are drained.

It is recommended that pressure gages be provided at the entering and leaving water connections to measure pressure drop through the heat exchanger. Gages may be installed as shown in the table below. Pressure gages installed at the vent and drain connections do not include nozzle pressure losses.

Use a reliable manometer to measure pressure differential when determining water flow. Regular gages are insensitive and do not provide an accurate measurement of flow conditions.

PRESSURE GAGE LOCATION

NUMBER OF PASSES	GAGE LOCATION (Cooler or Condenser)
Even	Two gages in waterbox with nozzles
Odd	One gage in each waterbox

Rupture disk piping

All 16LJ chillers are equipped with a rupture disk. It is recommended that piping from the rupture disk be routed to appropriate areas away from the machine in accordance with Carrier-Sanyo's written installation instructions, the latest version of ANSI/ASHRAE-15 (American National Standards Institute/American Society of Heating, Refrigeration, and Air Conditioning Engineers), and any local jurisdictional requirements that may apply. Piping should be adequately supported and the proper fittings should be provided to allow periodic inspection of the disk. Refer to the machine dimensional drawing for the exact location of the rupture disk on the chiller.

Service access

To perform routine service or maintenance, allow 3 ft clearance on all sides of the machine and 8 in. above the chiller. Tube removal space equal to the overall length of the unit should be provided on at least one end of the 16LJ chiller. The absorber and condenser waterbox covers are hinged to permit easy opening and access for routine tube cleaning.

Thermal insulation

Thermal insulation of cold and hot machine surfaces should be done after final installation at jobsite. Refer to thermal insulation drawings for details on application technique and specific areas of the machine to be insulated. Insulation material should be Armaflex or equal for cold surfaces and fiberglass or equal for hot surfaces. Surface area requirements are per table below.

THERMAL INSULATION SURFACE AREA REQUIREMENTS (sq ft)

UNIT 16LJ	INSULATION THICKNESS			
	Hot Surface		Cold Surface	
	3 in.	1 $\frac{1}{8}$ in.	2 in.	1 $\frac{1}{8}$ in.
11	30.1	17.3	43.0	3.3
12	30.1	19.4	43.0	3.3
13	40.9	20.5	59.3	3.3
14	40.9	23.7	59.3	3.3
21	43.0	26.9	65.7	4.3
22	43.0	26.9	65.7	4.3
23	56.0	33.4	81.8	5.4
24	56.0	35.5	81.8	5.4
31	64.6	37.6	91.5	5.4
32	64.6	38.8	91.5	5.4
41	71.0	39.9	106.7	5.4
42	71.0	42.0	106.7	5.4
51	81.8	51.7	148.5	7.5
52	90.4	54.9	161.5	7.5
53	99.0	57.0	173.3	7.5

→ **Hot water control valve**

The hot water control valve for the 16LJ chiller is not part of the standard scope of supply of the unit. It is available as a field-installed accessory and is intended for installation at the jobsite. The valve should be installed in the hot water return line leaving the generator section of the chiller. The accessory valve is a three-way globe mixing type with linear V-port trim. The valve has a carbon steel body with ANSI 150 psig flanged end connections. Valve sizes are normally 2½ to 6 in., depending on specific job requirements.

A 4 to 20 mA signal from the chiller control panel operates the valve through either an electric or pneumatic actuator. The control signal allows the valve to modulate the flow of hot water to meet the required cooling load. An electric actuator requires 120-1-60 vac power, supplied from a separate source, to operate the motor. If the valve is of the pneumatic type, an I/P (current-to-pressure) transducer is provided to convert the 4 to 20 mA control signal into a 3 to 15 psig input signal to the pneumatic actuator.

**ACCESSORY HOT WATER CONTROL VALVE
(Pneumatic Actuator Shown)**

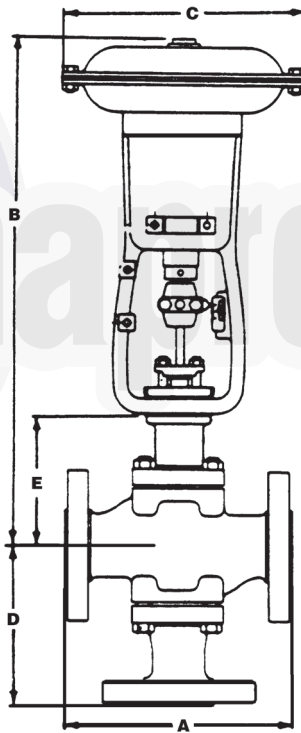

NOTE: All dimensions are in inches.

DIMENSIONS — FLANGED ENDS (150 psig Carbon Steel)

VALVE SIZE (in.)	A	B	C	D	E
2.5	10.88	23.75	12.81	7.25	6.25
3	11.75	28.25	15.0	7.56	8.13
4	13.88	29.25	15.0	9.38	9.13
6	17.75	38.25	17.5	11.56	12.88

Application data (cont)



HEAT EXCHANGER STANDARD PASS AND NOZZLE LOCATION

UNIT 16LJ	EVAPORATOR		ABSORBER		CONDENSER		GENERATOR	
	Pass Qty	Inlet Location	Pass Qty	Inlet Location	Pass Qty	Outlet Location	Pass Qty	Inlet Location
11	5	R	4	R	2	R	6	R
12	5	R	4	R	2	R	4	R
13-22	3	R	4	L	2	L	4	L
23-51	3	R	2	L	2	L	3	R
52-53	2	L	2	L	2	L	3	R

LEGEND

- L — Left End (when facing control panel)
- R — Right End (when facing control panel)

HEAT EXCHANGER STANDARD WATERBOX AND CROSSOVER PIPE CONFIGURATION

UNIT 16LJ	EVAPORATOR		ABSORBER		CONDENSER		CROSSOVER PIPE INCLUDED	
	Inlet	Outlet	Inlet	Outlet	Inlet	Outlet	Yes	Yes
11-53	N	N	M	M	M	M	Yes	Yes

LEGEND

- M — Marine Type Waterbox
- N — Nozzle-In-Head Waterbox

AVAILABLE NOZZLE ARRANGEMENTS

UNIT 16LJ	CHILLED WATER										COOLING WATER										HOT WATER										
	6 pass		5 pass		4 pass		3 pass		2 pass		4 + 2 pass		3 + 2 pass		3 + 1 pass		2 + 2 pass		2 + 1 pass		6 pass		4 pass		3 pass		2 pass		1 pass		
	I	O	I	O	I	O	I	O	I	O	I	O	I	O	I	O	I	O	I	O	I	O	I	O	I	O	I	O	I	O	I
11	L	L	R	L	L	L	R	L	L	L	R	R	L	R	L	L	—	—	R	L	R	R	R	R	L	R	R	R	—	—	
12	L	L	R	L	L	L	R	L	L	L	R	R	L	R	—	—	R	R	R	L	—	—	R	R	L	R	R	R	—	—	
13	—	—	R	L	L	L	R	L	L	L	L	L	R	L	R	R	—	—	L	R	L	L	L	R	L	L	L	—	—		
14	L	L	R	L	L	L	R	L	L	L	L	L	R	L	—	—	L	L	L	R	—	—	L	R	L	L	L	—	—		
21	L	L	R	L	L	L	R	L	L	L	L	L	R	L	—	—	L	L	L	R	L	L	L	R	L	L	L	—	—		
22	—	—	R	L	L	L	R	L	L	L	L	L	R	L	—	—	L	L	L	R	—	—	L	L	R	L	L	—	—		
23	L	L	R	L	L	L	R	L	L	L	L	L	R	L	R	R	L	L	L	R	L	L	L	R	L	L	L	R	L	L	
24	—	—	R	L	L	L	R	L	L	L	L	L	R	L	R	R	L	L	L	R	—	—	L	L	R	L	L	L	R	L	
31	—	—	—	—	L	L	R	L	L	L	L	L	R	L	R	R	L	L	L	R	—	—	R	R	L	R	R	R	L	R	
32	—	—	—	—	L	L	R	L	L	L	—	—	R	L	R	R	L	L	L	R	—	—	R	R	L	R	R	R	L	R	
41	—	—	—	—	L	L	R	L	L	L	—	—	R	L	R	R	L	L	L	R	—	—	L	L	R	L	L	L	R	L	
42	—	—	—	—	L	L	R	L	L	L	—	—	R	L	R	R	L	L	L	R	—	—	L	L	R	L	L	L	R	L	
51	—	—	—	—	L	L	R	L	L	L	L	L	R	L	R	R	L	L	L	R	—	—	L	L	R	L	L	L	R	L	
52	—	—	—	—	L	L	R	L	L	L	—	—	R	L	R	R	L	L	L	R	—	—	L	L	R	L	L	L	R	L	
53	—	—	—	—	L	L	R	L	L	L	—	—	R	L	R	R	L	L	L	R	—	—	L	L	R	L	L	L	R	L	

LEGEND

- I — In
- O — Out
- L — Nozzle location on LEFT end (when facing control panel)
- R — Nozzle location on RIGHT end (when facing control panel)
- Standard nozzle arrangement

Electrical data



UNIT VOLTAGE

460-3-60

UNIT 16LJ	PUMP/MOTOR (kW)			RLA			TOTAL AMPS	MCA	MFA	kW
	AP	RP	PP	AP	RP	PP				
11	1.1	0.2	0.75	2.7	1.2	1.45	6.2	7.5	10	4.3
12	1.1	0.2	0.75	2.7	1.2	1.45	6.2	7.5	10	4.3
13	1.1	0.2	0.75	2.7	1.2	1.45	6.2	7.5	10	4.3
14	1.1	0.2	0.75	2.7	1.2	1.45	6.2	7.5	10	4.3
21	2.2	0.2	0.75	5.1	1.2	1.45	8.6	10.4	15	5.9
22	2.2	0.2	0.75	5.1	1.2	1.45	8.6	10.4	15	5.9
23	2.2	0.3	0.75	5.1	1.3	1.45	8.7	10.4	15	5.9
24	2.2	0.3	0.75	5.1	1.3	1.45	8.7	10.4	15	5.9
31	3.0	0.3	0.75	6.7	1.3	1.45	10.3	12.9	20	7.2
32	3.0	0.3	0.75	6.7	1.3	1.45	10.3	12.9	20	7.2
41	3.0	0.3	0.75	6.7	1.3	1.45	10.3	12.9	20	7.2
42	3.0	0.3	0.75	6.7	1.3	1.45	10.3	12.9	20	7.2
51	3.0	0.3	0.75	6.7	1.3	1.45	10.3	12.9	20	7.2
52	3.0	0.3	0.75	6.7	1.3	1.45	10.3	12.9	20	7.2
53	3.0	0.3	0.75	6.7	1.3	1.45	10.3	12.9	20	7.2

208-3-60

UNIT 16LJ	PUMP/MOTOR (kW)			RLA			TOTAL AMPS	MCA	MFA	kW
	AP	RP	PP	AP	RP	PP				
11	1.1	0.2	0.75	5.4	2.2	3.2	12.7	15.6	20	4.0
12	1.1	0.2	0.75	5.4	2.2	3.2	12.7	15.6	20	4.0
13	1.1	0.2	0.75	5.4	2.2	3.2	12.7	15.6	20	4.0
14	1.1	0.2	0.75	5.4	2.2	3.2	12.7	15.6	20	4.0
21	2.2	0.2	0.75	10.2	2.2	3.2	17.5	21.7	30	5.5
22	2.2	0.2	0.75	10.2	2.2	3.2	17.5	21.7	30	5.5
23	2.2	0.3	0.75	10.2	2.4	3.2	17.7	21.9	30	5.6
24	2.2	0.3	0.75	10.2	2.4	3.2	17.7	21.9	30	5.6
31	3.0	0.3	0.75	13.8	2.4	3.2	21.3	27.5	40	7.0
32	3.0	0.3	0.75	13.8	2.4	3.2	21.3	27.5	40	7.0
41	3.0	0.3	0.75	13.8	2.4	3.2	21.3	27.5	40	7.0
42	3.0	0.3	0.75	13.8	2.4	3.2	21.3	27.5	40	7.0
51	3.0	0.3	0.75	13.8	2.4	3.2	21.3	27.5	40	7.0
52	3.0	0.3	0.75	13.8	2.4	3.2	21.3	27.5	40	7.0
53	3.0	0.3	0.75	13.8	2.4	3.2	21.3	27.5	40	7.0

LEGEND

- AP — Absorbent Pump
- MCA — Minimum Circuit Ampacity
- MFA — Maximum Fuse Amps
- PP — Purge Pump
- RLA — Rated Load Amps
- RP — Refrigerant Pump

NOTES:

1. MCA and MFA include absorbent pump, refrigerant pump, purge pumps, palladium cell heater and control circuit.
2. kW includes refrigerant pump, absorbent pump, purge pump, palladium cell heater and control circuit.
3. Control circuit voltage = 24-1-60.
4. Palladium cell voltage = 230-1-60 (460-3-60 power supply) and 208-1-60 (208-3-60 power supply).

STANDARD VOLTAGE (3-Ph, 60 Hz)	FOR USE ON SUPPLY VOLTAGES
208	200 to 208-volt systems
460	440 to 480-volt systems

Controls



Microprocessor controls

Microprocessor controls provide the safety, interlock, capacity control, and indications necessary to operate the chiller in a safe and efficient manner.

Control system

The microprocessor control on each 16LJ chiller is factory-mounted, factory-wired, and factory-tested to ensure chiller protection and efficient capacity control. In addition, the program logic ensures proper starting, stopping, and cycling of the chiller.

Features

Control system

- Diagnostic check
- Keypad interface for display, set point control and system configuration
- Local and remote operation modes
- Recall of alarm/alert messages
- Extensive diagnostic and service capabilities
- Advanced crystallization protection

Safety cutouts

- Absorbent pump motor overload
- Refrigerant pump motor overload
- Purge pump motor overload
- Low chilled water temperature

- Low cooling water temperature
- Generator high temperature
- Generator high pressure
- Chilled water flow
- Optional cooling water flow
- Chilled water pump interlock
- Cooling water pump interlock
- High solution concentration

Overrides

- Solution concentration control
- Desolidification mode

Capacity control

- Leaving chilled water control
- Chilled water reset

Indications

- Chiller operating status
- Dilution cycle
- Power-on
- Pre-alarm alert
- Alarm
- Safety shutdown messages
- Elapsed time (hours of operation)
- Remote/local
- Standby mode

Climaproyectos.com

**TYPICAL 16LJ ABSORPTION CHILLER CONTROL PANEL
FRONT AND LEFT SIDE VIEW**

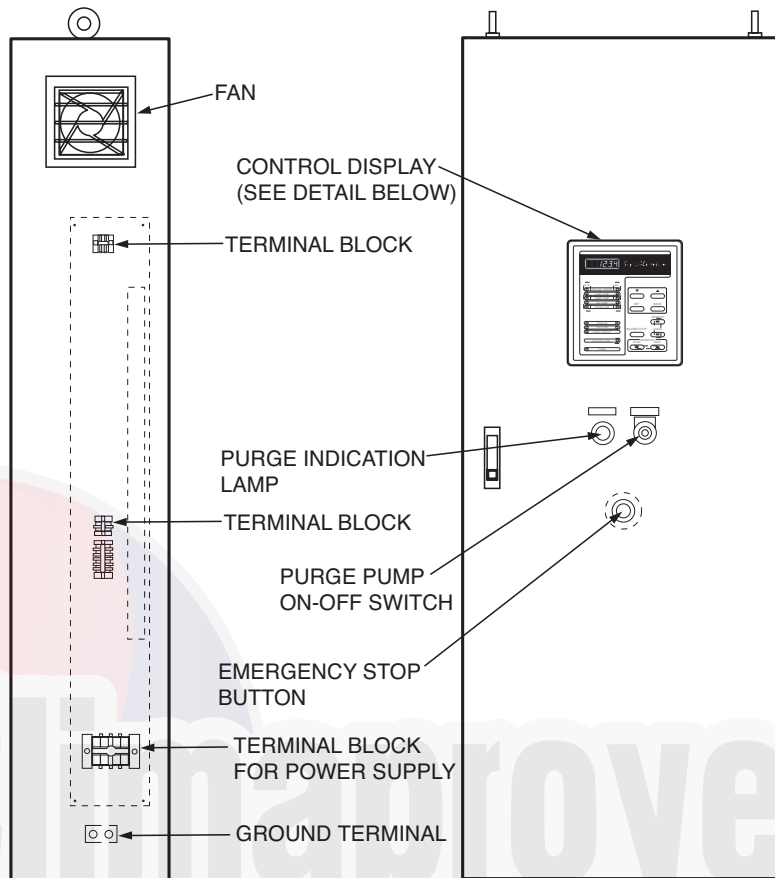

CONTROL DISPLAY

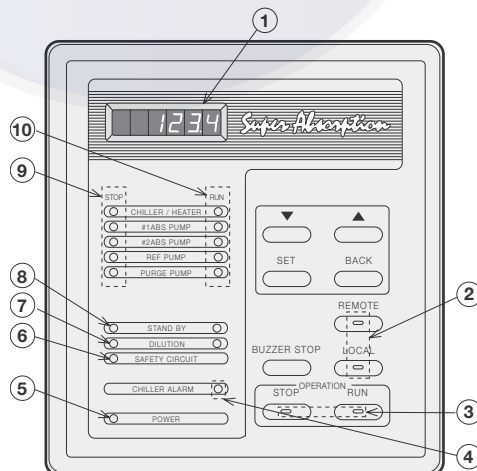

NUMBER	DESCRIPTION
1	Data display
2	Remote/local select button with lamp
3	Operation select button with lamp
4	Alarm indication lamp
5	Power indication lamp
6	Safety circuit indication lamp
7	Dilution indication lamp
8	Stand by indication lamp
9	Stop indication lamp
10	Operation indication lamp

TYPICAL 16LJ ABSORPTION CHILLER CONTROL PANEL (cont)
INSIDE AND RIGHT SIDE VIEW

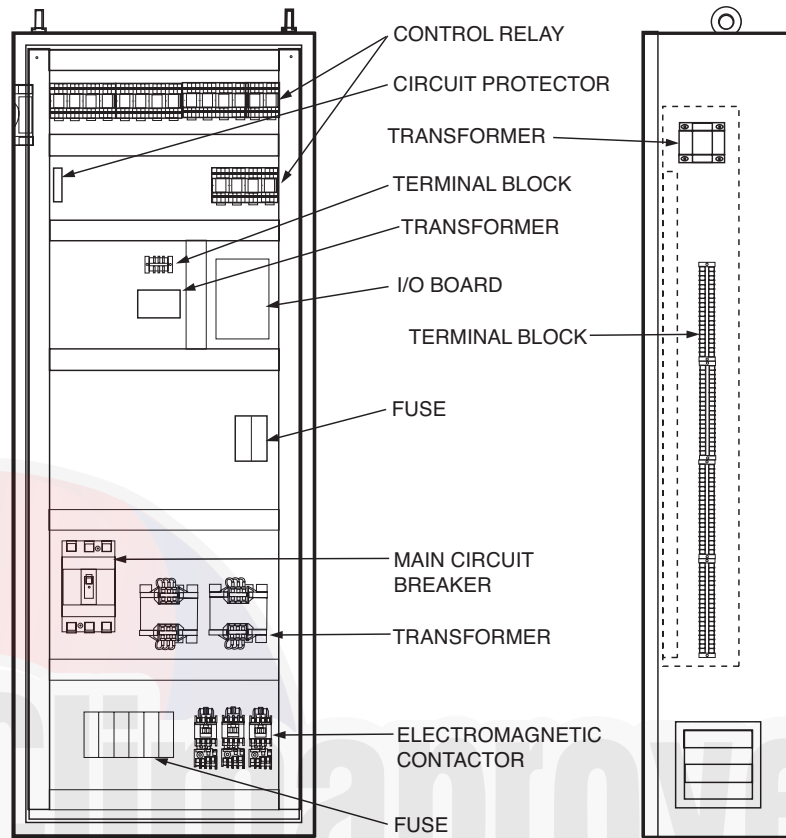

Typical piping

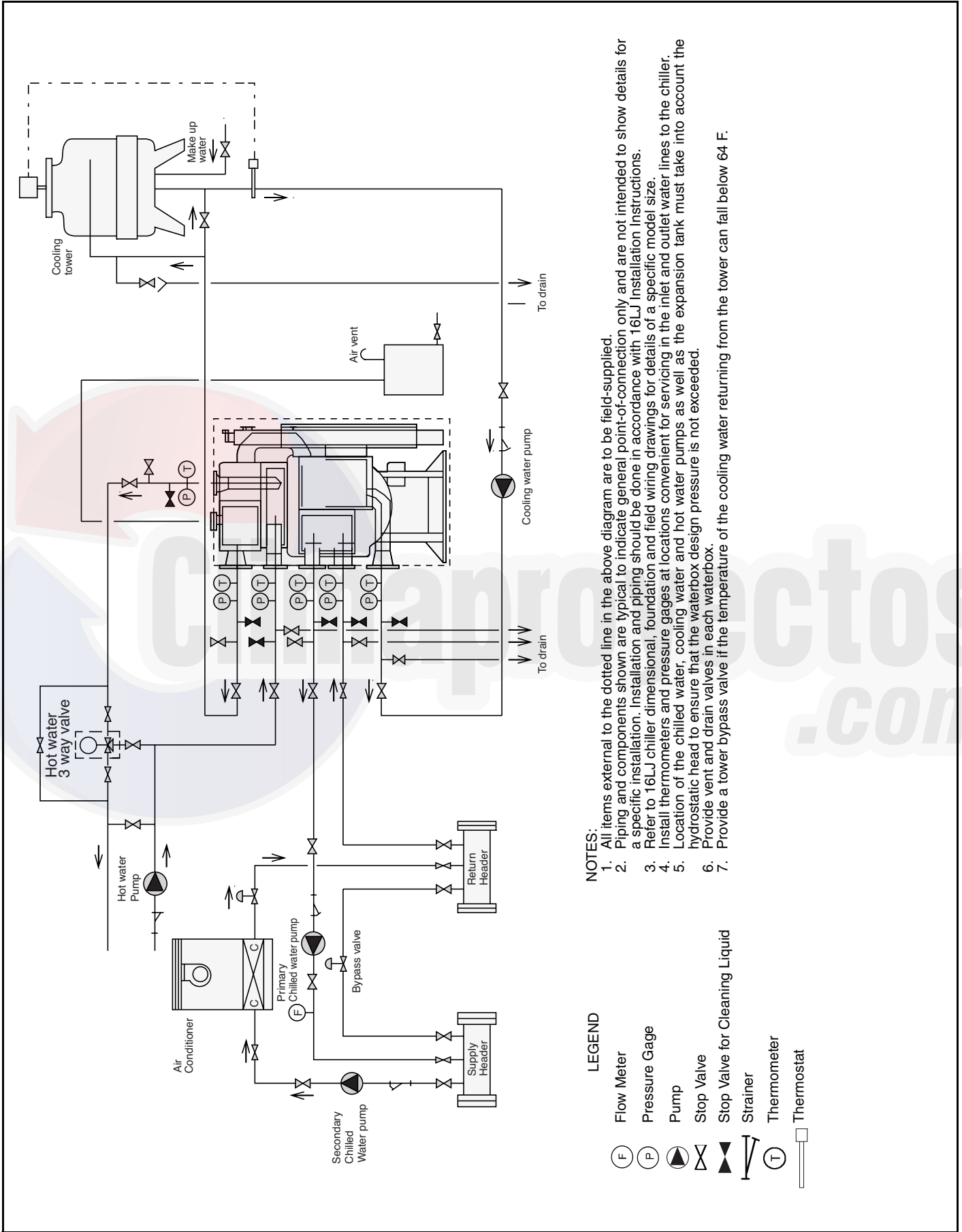

NOTES:

1. All items external to the dotted line in the above diagram are to be field-supplied.
2. Piping and components shown are typical to indicate general point-of-connection only and are not intended to show details for a specific installation. Installation and piping should be done in accordance with 16LJ Installation Instructions.
3. Refer to 16LJ chiller dimensional, foundation and field wiring drawings for details of a specific model size.
4. Install thermometers and pressure gages at locations convenient for servicing in the inlet and outlet water lines to the chiller.
5. Location of the chilled water, cooling water and hot water pumps as well as the expansion tank must take into account the hydrostatic head to ensure that the waterbox design pressure is not exceeded.
6. Provide vent and drain valves in each waterbox.
7. Provide a tower bypass valve if the temperature of the cooling water returning from the tower can fall below 64 F.

LEGEND

- Flow Meter (F)
- Pressure Gage (P)
- Pump (P)
- Stop Valve (V)
- Stop Valve for Cleaning Liquid (V)
- Strainer (S)
- Thermometer (T)
- Thermostat (T)

Guide specifications



Single-Effect, Low Temperature Hermetic Absorption Liquid Chillers

Size Range: **75 to 525 Tons**

Carrier-Sanyo Model Number: **16LJ**

Part 1 — General

1.01 SYSTEM DESCRIPTION

Electronically controlled, single effect (one-stage) absorption liquid chiller utilizing hermetic refrigerant and absorbent pumps, lithium bromide solution as the absorbent, and water as the refrigerant. Low temperature hot water shall be supplied to the generator as the heat source.

1.02 QUALITY ASSURANCE

- A. Chiller performance shall be rated in accordance with ARI Standard 560-2000.
- B. Chiller shall be manufactured in accordance with ANSI/ASHRAE 15 (latest edition) Safety Code for Mechanical Refrigeration.
- C. Chiller shall be designed and constructed to meet applicable UL requirements and shall bear the UL label.
- D. Each chiller shall undergo a series of standard factory tests to ensure that the unit is leak tight, that all electrical components operate as intended, and that every aspect of unit fabrication meets stringent quality standards in accordance with good practice and the manufacturer's quality assurance requirements.

1. The shellside of each chiller shall be leak tested by pressurizing to 7 psig with nitrogen and then checked by spraying a soap and water mixture on all welds, tube joints and/or gasketed joints to identify any major leaks. Afterward, a mass spectrometer test shall be performed by evacuating the unit to 0.01 mm Hg absolute, covering the machine with a vinyl tent and introducing helium gas under the tent. Any remaining leaks will allow the helium to be drawn into the shellside of the machine. The acceptable total leak rate as measured by the mass spectrometer test shall not exceed .000002 cc/sec standard air.
2. The tubeside of the evaporator, absorber, condenser and generator shall be hydrostatically tested at 1.5 times rated design pressure and held for 1 hour.
3. All machine wiring shall undergo an insulation resistance test. The machine control panel and all electrical components shall also be functionally tested to verify continuity and proper electrical operation.
4. Final assembly inspection shall consist of verifying that all valves, controls, instrumentation, pumps, purge components and all other machine components have been properly installed on the machine.
5. Each unit shall be checked for overall appearance and dimensional accuracy.

6. Final inspection shall be performed on each unit to check that the nameplate data is correct and that all accessories are furnished as required.

1.03 DELIVERY, STORAGE, AND HANDLING

- A. Unit shall be stored and handled in accordance with the manufacturer's recommendations.
- B. Unit shall be factory-charged with lithium bromide solution if the machine is configured to ship in one piece. For shipments of multiple pieces, charging of lithium bromide solution shall be performed at the jobsite in accordance with the manufacturer's written instructions.
- C. All units shall be shipped with 3 psig nitrogen pressure.
- D. Chiller shall be shipped with nameplates indicating name of manufacturer, model size, serial number and all other pertinent machine data.

1.04 WARRANTY

Manufacturer shall guarantee the chiller against defects in materials or workmanship for a period of one year from date of initial operation or 18 months from date of shipment, whichever occurs first. Manufacturer shall provide the labor to repair or replace any part found to be defective in material or workmanship within the warranty period.

Part 2 — Products

2.01 EQUIPMENT

- A. General:

Absorption liquid chiller shall include evaporator, absorber, condenser, generator, solution heat exchanger, refrigerant/absorbent pumps, purge system, piping, wiring, controls and auxiliaries. Standard shipment of the machine shall be in one piece. Initial charge of lithium bromide shall be shipped inside the machine for all single-piece shipments. For multiple-piece shipments, initial charge of lithium bromide shall be shipped separately for charging at the jobsite. Generator shall be designed for operation on low temperature hot water as specified on the equipment schedule. A rupture disk shall be provided as standard on all machines.
- B. Operating Characteristics:
 1. Chiller operation shall be characteristic of a single-effect absorption cycle. The weak solution pumped from the absorber to the generator shall initially pass through a solution heat exchanger to improve operating efficiency by preheating the weak solution on the tube side with the strong solution returning from the generator on the shellside.
 2. Unit shall be capable of continuous operation from 100 to 10% capacity, with entering condenser water temperatures as low as 64 F without the need for a cooling tower bypass valve. Thermostat on/off control of the cooling tower fan is recommended when cooling water temperature falls below 64 F.

C. Heat Exchangers:

1. All heat exchangers shall be of shell and tube construction with shells, tube sheets, tube support sheets and waterboxes fabricated of carbon steel. All heat exchangers shall incorporate straight tubes. Tube material shall be copper for all heat exchangers. The evaporator, absorber, condenser and generator tubes shall be rolled into grooved tubesheets and expanded into tube support sheets, and shall be individually replaceable.
2. The evaporator, absorber and condenser waterboxes shall be designed for 150 psig working pressure. The absorber and condenser waterboxes shall be hinged to permit access to all tubes from either end. Nozzle-in-head (NIH) type waterboxes shall be supplied on the evaporator while the absorber-condenser waterboxes shall be marine type. Waterboxes shall be provided with vent and drain connections. Epoxy painting of the waterboxes and tube sheets shall be provided for corrosion protection. ANSI 150 psig R.F. (raised face) flanges shall be furnished on all waterbox nozzle connections.
3. The generator tube side shall be designed for 150 psig working pressure for use with low temperature hot water.
4. A solution heat exchanger shall be an integral part of the machine to increase cycle efficiency by preheating the weak solution on its way to the generator while pre-cooling the strong solution returning from the generator.
5. Dispersion trays shall evenly distribute refrigerant over the evaporator tubes and lithium bromide over the absorber tubes. These trays shall be fabricated of stainless steel to ensure continuous, corrosion-free, high-efficiency operation.

D. Pump/Motors:

Refrigerant and absorbent pump/motor assemblies shall be of the self contained, leakproof, hermetic type, without an external seal water system to minimize air leakage into the machine. Lubrication and cooling shall be accomplished by the fluid being pumped; auxiliary water piping for cooling and lubrication shall not be acceptable. Each pump casing shall be welded into the piping at the factory and shall be furnished with isolation valves on the suction and discharge side. Each pump shall include spring-loaded, wear-compensating tapered carbon bearings to ensure long life and reliability. Pump/motor assemblies shall be designed for 25,000 hours of normal operation between inspections.

E. Purge System:

An automatic purge system shall be furnished to provide a continuous purging action whenever the chiller is in operation to assure long machine life and efficient performance. Noncondensables shall be removed from the absorber by a liquid eductor,

which shall use flow from the absorbent pump to create a suction. Noncondensables shall be stored external to the unit and shall be prevented from diffusing back into the machine when the unit is not operating. A palladium cell shall be provided to automatically vent hydrogen gas from the purge chamber to the atmosphere. It shall be continuously energized, even during machine shutdown. Further evacuation of the external storage chamber shall be accomplished with a factory-mounted purge pump, piped and wired to the machine. The need to operate the purge pump shall be indicated on the front of the control panel.

F. Controls, Safeties and Diagnostics:

1. Controls:

- a. The chiller shall be provided with a factory-installed and factory-wired microprocessor control system with modular component construction. The controls shall be of the PID type and shall continuously monitor the operation of the chiller and perform self-diagnostic checks to ensure that all control limits are satisfied and maintained. The system shall include a control center, power supply, temperature sensors, pressure sensors and all necessary auxiliary devices required for safe and proper chiller operation housed in a NEMA-1 enclosure with a hinged, lockable door. Control power shall be 24-1-60.

The chiller control system shall have the ability to interface and communicate with a building management system with additional hardware.

The control system shall include a 7-segment light-emitting diode (LED) display screen with function keys, emergency stop button and indication lamps. The microprocessor shall be configurable to display either English or metric units.

- b. The control panel display screen shall allow an operator to easily set and display the operating mode and configurable settings of the machine. The display shall indicate power on, chiller run status, safety circuit and alarm status, remote/local operation, standby mode and dilution cycle operation. Data input and machine settings shall be done via a data select key and shall allow scrolling through the individual chiller parameter settings.

Guide specifications (cont)



- c. Monitoring the operation of the chiller shall be done on a continuous basis. The display shall indicate all pertinent system operating parameters and alarms, as necessary, including the following:
 - 1) Chiller operating hours.
 - 2) Chilled water inlet temperature.
 - 3) Chilled water outlet temperature.
 - 4) Chilled water temperature set point.
 - 5) Cooling water inlet temperature.
 - 6) Condenser temperature.
 - 7) Generator temperature.
 - 8) Hot water inlet temperature.
 - 9) Hot water outlet temperature.
 - 10) Absorbent pump start counter and operating hours.
 - 11) Refrigerant pump start counter and operating hours.
 - 12) Purge pump start counter and operating hours.
 - 13) Chiller start counter.
 - 14) Purge tank pressure.
 - d. Capacity control shall be by means of electronically modulating the accessory hot water control valve to maintain the temperature of the chilled water. Load modulation shall be from 100% to 10% of machine full load under normal ARI conditions. The hot water control valve shall be positioned by a PID control algorithm to ensure precise control of desired chilled water temperature without hunting or overshooting the set point.
 - e. The microprocessor control system shall include a programmed sequence to ensure machine readiness prior to machine start-up. The microprocessor shall automatically enable and interlock the chilled water pump, cooling water pump and cooling tower fans upon chiller activation.
 - f. Upon request to start the chiller, the control system shall start the chilled water pump and verify chilled water flow. The controller shall then start the cooling water pump and verify interlock signal, before starting tower fan(s), absorbent pump and refrigerant pump.
 - g. The control system shall automatically sense impending abnormalities in the absorption operating cycle and take the following actions to either self-correct and/or limit the machine from approaching cycle crystallization line:
 - 1) Close hot water control valve for a set period.
 - 2) Stop the operation of the machine after performing a dilution cycle if the solution concentration is still over the pre-set level.
 - h. The rate at which the accessory hot water control valve is opened shall be precisely controlled.
 - i. The control system shall automatically cycle the refrigerant pump whenever the leaving chilled water temperature falls below the desired set point. The chilled water pump shall remain on and when the leaving chilled water temperature rises above the set point, the refrigerant pump shall automatically restart.
 - j. The control center shall allow reset of the chiller water temperature set point based upon any one of the following criteria:
 - 1) Chilled water reset based on an external 4 to 20 mA signal.
 - 2) Chilled water reset based on cooling water inlet temperature.
 - k. When the stop button is pressed or remote contacts open the control center shall immediately drive the hot water control valve to the closed position and initiate the normal shutdown sequence including dilution cycle. The display shall indicate that the machine is in the dilution cycle.
2. Safeties:
- a. Unit shall automatically shut down when any of the following conditions occur. In addition, the chiller goes into alarm mode and indicates the reason for the shutdown on the chiller data display.
 - 1) Absorbent pump motor overload.
 - 2) Refrigerant pump motor overload.
 - 3) Purge pump motor overload.
 - 4) Low chilled water temperature.
 - 5) Low cooling water temperature.
 - 6) Generator high temperature.
 - 7) Generator high pressure.
 - 8) Loss of chilled water flow.
 - 9) (Optional) loss of cooling water flow.
 - 10) Loss of chilled water pump interlock.
 - 11) Loss of cooling water pump interlock.
 - 12) High solution concentration.
 - b. The control system shall detect conditions that approach protective limits and take self-corrective action prior to an alarm occurring. The system shall automatically reduce chiller capacity when any of the following parameters are outside their normal operating range:
 - 1) Low cooling water inlet temperature.
 - 2) High cooling water inlet temperature.
 - 3) High solution concentration.
3. Diagnostics and Service:
- a. The chiller control system shall execute a series of self-diagnostic checks whenever power is first turned on to determine if temperatures are within pre-start limits, thereby allowing start-up to proceed. If any of the

limits are exceeded, an alert message will be displayed, informing the operator of the cause of the pre-start alert.

b. The control system shall provide an alarm display on the front of the panel for any sensor that has failed. These sensors include:

- 1) Chilled water inlet temperature.
- 2) Chilled water outlet temperature.
- 3) Cooling water inlet temperature.
- 4) Cooling water outlet temperature.
- 5) Cooling water intermediate temperature.
- 6) Hot water inlet temperature.
- 7) Hot water outlet temperature.
- 8) Condenser temperature.
- 9) Refrigerant temperature.
- 10) Diluted solution temperature.
- 11) Generator temperature.
- 12) Purge tank pressure.
- 13) Steam condensate temperature.

c. The chiller controls shall display maintenance messages and alarms when efficient operation of the chiller is in jeopardy or when immediate attention is necessary. When operating conditions are predicted to be problematic, the following messages shall be displayed on the panel:

- 1) Purge tank high pressure.
- 2) Cooling water tubes excessive fouling.
- 3) Cooling water high temperature.
- 4) Power failure.

4. Building Control System Interface:

The chiller control system shall have the ability to interface and communicate directly to the building control system with additional field-installed hardware and software.

G. Electrical Requirements:

1. Power supply to the unit shall be 3 ph, 60 Hz with voltages of 208 or 460 as specified on the equipment schedule. A control transformer shall provide 24-volt single-phase secondary power for the control panel.
2. Contractor/owner shall supply and install the electrical power line and all auxiliary electrical protection devices per local code requirements and as indicated necessary by the chiller manufacturer.
3. Contractor/owner shall supply and install electrical wiring and devices required to interface the chiller controls with the building controls system if applicable.

H. Piping Requirements:

1. Piping and instrumentation for the chilled water, cooling water and hot water shall be supplied and installed by the contractor/owner.
2. Absorber-condenser crossover piping shall be furnished by the chiller manufacturer.

3. Cooling water flow switch shall be supplied by either the chiller manufacturer or the contractor/owner.

4. Piping from the rupture disk shall be provided and installed by the contractor/owner and piped in accordance with the chiller manufacturer's written instructions and any local jurisdictional requirements.

I. Thermal Insulation:

Insulation of the evaporator, refrigerant pump, sump, piping and chilled water headers, in addition to any hot surfaces shall be field supplied and installed on the machine. Chiller manufacturer shall recommend the material and specify surface area to be insulated.

J. Sound Level:

The overall sound pressure level of the chiller shall not exceed 80 dbA when measured per ARI Standard 575-1994.

K. Start-up:

1. Unit manufacturer shall provide a factory-trained service representative, employed by the chiller manufacturer, to perform and/or supervise chiller pressure test (when required), charge chiller with refrigerant (water) and lithium bromide solution, place unit into operation, and calibrate all controls in accordance with the manufacturer's written start-up, operating and maintenance instructions.
2. After unit start-up has been performed, the same factory representative shall be available for a period of instruction not to exceed 4 hours to instruct the owner's personnel in the proper start-up, operating and maintenance procedures.
3. Manufacturer shall provide the following documentation and literature:
 - a. Installation Instructions.
 - b. Start-Up, Operating and Maintenance Instructions.
 - c. Dimensional Drawing.
 - d. Foundation Drawing.
 - e. Field Wiring Diagram.

L. Options and Accessories:

1. Marine Waterboxes:

Marine waterboxes with removable covers to facilitate tube cleaning and maintenance shall be furnished when specified on the equipment schedule.

2. High-Pressure Waterboxes:

Waterboxes rated for 300 psig working pressure with removable covers shall be furnished when specified on the equipment schedule.

3. Special Tubing:

Tubing of non-standard materials, geometry or wall thickness shall be provided when specified on the equipment schedule.

Guide specifications (cont)



4. Shipping Configuration:

Chiller shall ship either fully assembled or in multiple pieces as specified on the equipment schedule.

5. Victaulic Nozzle Connections:

Victaulic grooves shall be provided on all water-box nozzle connections when specified on the equipment schedule.

6. Cooling Water Flow Switch:

Cooling water flow switch, rated for either 150 psig or 300 psig, shall be factory supplied when specified on the equipment schedule.

7. Isolation Package:

A vibration isolation package consisting of neoprene isolation pads shall be furnished when specified on the equipment schedule.

8. Thermometer Set:

A package of 5 adjustable angle thermometers shall be factory-supplied for field installation when specified on the equipment schedule. Each shall have a 9 in. scale with a working range of 0° F to 120 F and shall be equipped with a 3/4-in. NPT brass well.

→

9. Hot Water Control Valve:

An accessory hot water control valve shall be provided when specified on the equipment schedule.



