



## **SUBMITTAL**

### **Project**

Chillers 2023

### **Date**

lunes, 13 de marzo de 2023

### **General Contractor**

### **Mechanical Contractor**

### **Mechanical Engineer**



# Table Of Contents

Project: Chillers 2023  
Prepared By:

03/15/2023  
09:42a. m.

Unit Report.....	3
Certified Drawing.....	4
Field Wiring Diagram.....	6
Acoustic Summary.....	9
Detailed Performance Report.....	10



## Unit Report For Chiller 20 TR 460

Project: Chillers 2023  
Prepared By:

03/15/2023  
09:42a. m.

### Unit Information

Tag Name:.....**Chiller 20 TR 460**  
 Model Number:.....**30RAP020**  
 Condenser Type:.....**Air Cooled**  
 Compressor Type:.....**Scroll**  
 Nameplate Voltage:.....**460-3-60** V-Ph-Hz  
 Quantity:.....**1**  
 Manufacturing Source:.....**Charlotte, NC USA**  
 Refrigerant:.....**R410A**  
 Independent Refrigerant Circuits:.....**1**  
 Capacity Control Steps:.....**2**  
 Minimum Capacity:.....**50.0** %  
 Shipping Weight:.....**1124** lb  
 Operating Weight:.....**1133** lb  
 Unit Length:.....**89** in  
 Unit Width:.....**41** in  
 Unit Height:.....**67** in

### Accessories and Installed Options

Evaporator Heater  
 Micro Channel  
 Low Sound - Aero Acoustic Fans  
 Single Point  
 Fixed Speed Condenser Fan

### Chiller Warranty Information (Note: for US & Canada only)

First Year - Parts Only (Standard)

### Ordering Information

Part Number	Description	Quantity
30RAP0206D-00100	Packaged Chiller	1
	Base Unit	
	Evaporator Heater	
	Micro Channel	
	Low Sound - Aero Acoustic Fans	
	Single Point	
	Fixed Speed Condenser Fan	

**Certified Drawing for Chiller 20 TR 460**

Project: Chillers 2023  
Prepared By:

03/15/2023  
09:42a. m.



# Certified Drawing for Chiller 20 TR 460

Project: Chillers 2023  
Prepared By:

03/15/2023  
09:42a. m.

UNIT	CENTER OF GRAVITY		UNIT HEIGHT		POWER ENTRY	WATER CONNECTION VICIAULIC IPS CARBON STEEL
	X	Y	H (STANDARD)	H (VALUE SOUND)		
30RA018	18.37 [467]	38.77 [985]	66.5 [1689]	61.0 [1549]	24.9 [631]	2"
30RA020	18.38 [467]	38.79 [985]	66.5 [1689]	61.0 [1549]	24.9 [631]	2"
30RA025	18.58 [472]	38.93 [989]	78.5 [1994]	73.0 [1854]	36.9 [936]	2"
30RA030	18.59 [472]	38.98 [990]	78.5 [1994]	73.0 [1854]	36.9 [936]	2"

**NOTES.**

1. DO NOT CAP OR OTHERWISE OBSTRUCT THE LIQUID LINE TEMPERATURE RELIEF.
2.  $\varnothing 7/8$  [22.4] PILOT HOLE PROVIDED FOR LOCATING FIELD POWER WIRING. ACTUAL HOLE REQUIRED DEPENDS ON FIELD WIRE SIZING.
3.  $\varnothing 0.437$  [11.10] HOLE USED FOR MOUNTING UNIT.
4. UNIT MUST HAVE CLEARANCES AS FOLLOWS:  
TOP - DO NOT RESTRICT.  
COIL SIDE - 42 [1067] FROM SOLID SURFACE.  
PANEL SIDE - 48 [1219] PER NEC.
5. SEE TABLE COLUMN H: DIMENSION FOR STANDARD FAN OR VALUE SOUND FAN OPTION.
6. CARRIER DOES NOT RECOMMEND INSTALLATION IN A PIT.
7. UNIT CAN BE HANDLED USING THE FORK TRUCK LIFT POCKETS.
8. WATER CONNECTIONS RECESSED 2 INCHES INSIDE UNIT. ALL WATER DRAIN AND VENTING HOLES ARE 1/4" NPT.

DIMENSIONS IN [ ] ARE IN MILLIMETERS

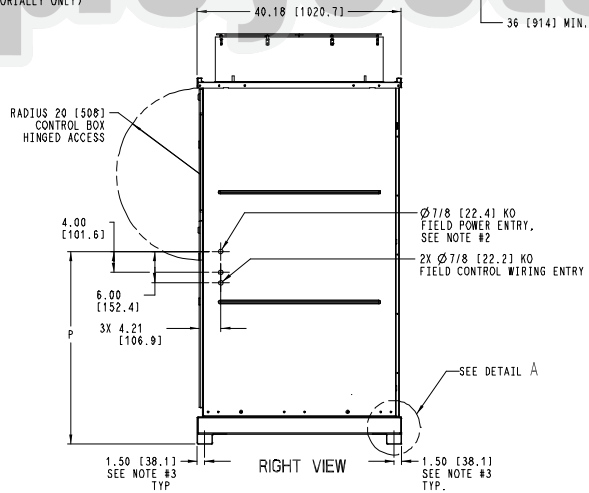
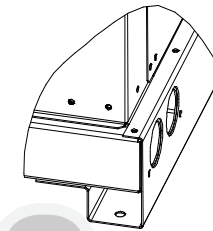
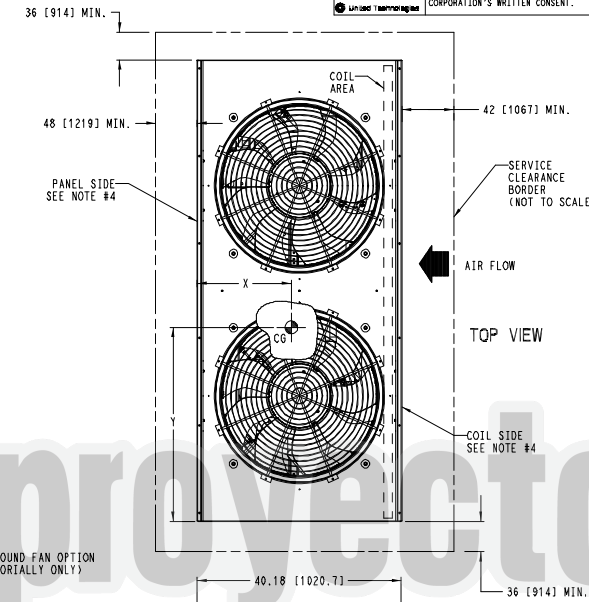
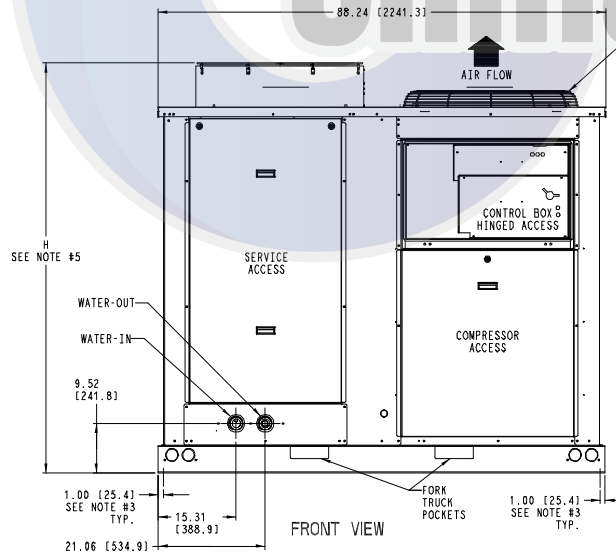

FOR LOW AMBIENT OPTION

DATE	SUPERCEDES	UNIT ASSY	REV
09/07/15	G	30RAP018-030 UNIT ASSY	H

# Field Wiring Diagram for Chiller 20 TR 460

Project: Chillers 2023  
Prepared By:

03/15/2023  
09:42a. m.

**NOTES:**

1. FACTORY WIRING IS IN ACCORDANCE WITH UL 1995 STANDARDS. FIELD MODIFICATIONS OR ADDITIONS MUST BE IN COMPLIANCE WITH ALL APPLICABLE CODES.
2. ALL UNITS OR MODULES HAVE SINGLE POINT PRIMARY POWER CONNECTION. MAIN POWER MUST BE SUPPLIED FROM A FIELD OR FACTORY SUPPLIED DISCONNECT.
3. WIRING FOR MAIN FIELD SUPPLY MUST BE RATED 75C. USE COPPER CONDUCTORS ONLY.
  - a. INCOMING WIRE SIZE RANGE FOR TERMINAL BLOCK WITH MCA UP TO 175 AMPS IS 14 AWG TO 2/0 FOR 10-60 TON CHILLERS.
  - b. INCOMING WIRE SIZE RANGE FOR TERMINAL BLOCK WITH MCA FROM 175.1 AMPS TO 335 AMPS IS 6 AWG TO 400 KCMIL FOR 10-60 TON CHILLERS.
  - c. INCOMING WIRE SIZE RANGE FOR TERMINAL BLOCK WITH MCA UP TO 420 AMPS IS 2 AWG TO 600KCMIL FOR 70-150 TON CHILLERS.
  - d. INCOMING WIRE SIZE RANGE FOR TERMINAL BLOCK WITH MCA FROM 420.1 AMPS TO 760 AMPS IS 6 AWG TO 500 KCMIL (TWO OPENINGS PER POLE) FOR 70-150 TON CHILLERS.
  - e. INCOMING WIRE SIZE RANGE FOR NON-FUSED DISCONNECT WITH MCA UP TO 100 AMPS IS 14AWG TO 3/0.
  - f. INCOMING WIRE SIZE RANGE FOR NON-FUSED DISCONNECT WITH MCA FROM 100.1 AMPS TO 250 AMPS IS 6AWG TO 350 KCMIL.
  - g. INCOMING WIRE SIZE RANGE FOR NON FUSED DISCONNECT WITH MCA FROM 250.1 TO 600 AMPS IS 3/0 AWG TO 500KCMIL (TWO OPENINGS PER POLE).
4. REFER TO CERTIFIED DIMENSIONAL DRAWINGS FOR EXACT LOCATIONS OF THE MAIN POWER AND CONTROL POWER ENTRANCE LOCATIONS.
5. TERMINALS 21 AND 25 OF THE LVT ARE FOR CONTROL OF CHILLED WATER PUMP1 (CWP1) STARTER. TERMINALS 21 AND 24 OF THE LVT ARE FOR CONTROL OF CHILLED WATER PUMP2 (CWP2) STARTER. THE MAXIMUM LOAD ALLOWED FOR THE CHILLED WATER PUMP RELAY IS 5 VA SEALED, 10 VA INRUSH AT 24 V. FIELD POWER SUPPLY IS NOT REQUIRED.
6. TERMINALS 18 AND 21 OF LVT ARE FOR AN ALARM RELAY. THE MAXIMUM LOAD ALLOWED FOR THE ALARM RELAY IS 5 VA SEALED, 10 VA INRUSH AT 24V. FIELD POWER SUPPLY IS NOT REQUIRED.
7. MAKE APPROPRIATE CONNECTIONS TO LVT AS SHOWN FOR ENERGY MANAGEMENT BOARD OPTIONS. THE CONTACTS FOR DEMAND LIMIT AND ICE DONE OPTIONS MUST BE RATED FOR DRY CIRCUIT APPLICATION CAPABLE OF HANDLING A 24VAC LOAD UP TO 50 MA. INSTALLATION OF OPTIONAL ENERGY MANAGEMENT BOARD REQUIRED.
8. REMOVE JUMPER BETWEEN TERMINALS 11 AND 17 WHEN FIELD CWP1 IS INSTALLED.
9. TERMINALS 13 & 14 OF TBS ARE FOR FIELD EXTERNAL CONNECTIONS FOR REMOTE ON-OFF. THE CONTACTS MUST BE RATED FOR DRY CIRCUIT APPLICATION CAPABLE OF HANDLING A 24VAC LOAD UP TO 50MA.

**LEGEND:**

- ALM R - ALARM RELAY (24V) 5 VA MAX
- AWG - AMERICAN WIRE GAUGE
- CWP - CHILLED WATER PUMP
- CWP1 - CHILLED WATER PUMP INTERLOCK
- EMM - ENERGY MANAGEMENT MODULE
- LVT - LOW VOLTAGE TERMINAL STRIP
- SPT - SPACE TEMPERATURE

- - - FIELD POWER WIRING
- - - FIELD CONTROL WIRING
- - - FACTORY INSTALLED WIRING
- FACTORY INSTALLED OPTION

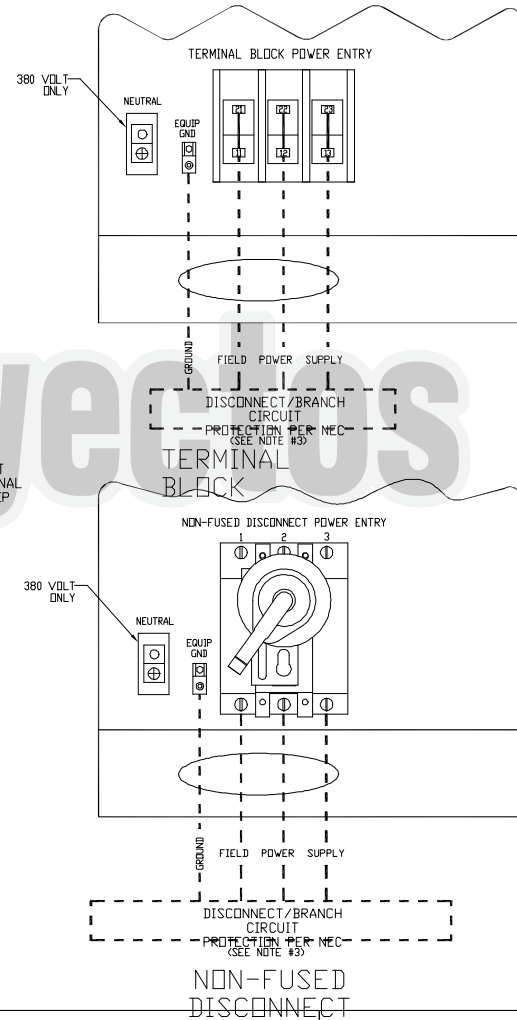
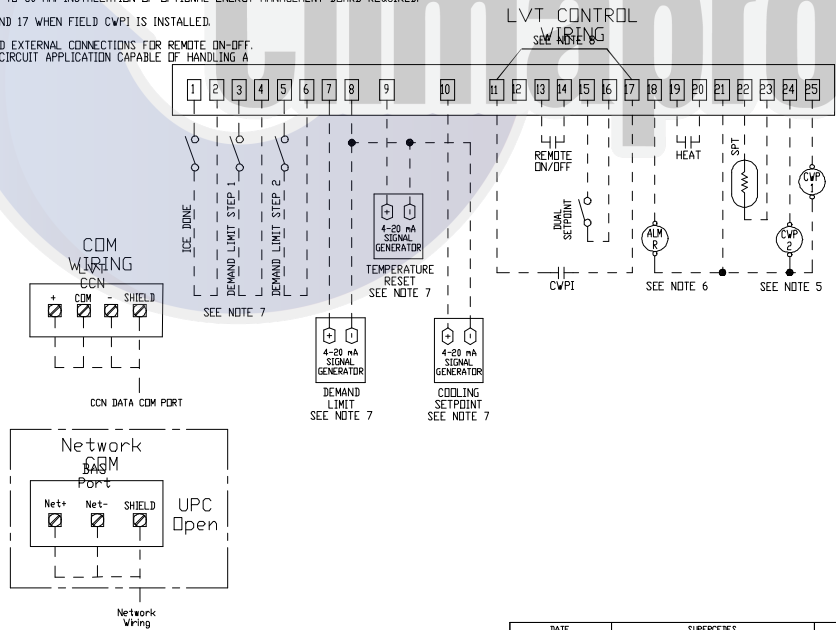

UNITED TECHNOLOGIES CARRIER P.O. BOX 4898 SYRACUSE, NY 13221  
 THIS DOCUMENT IS THE PROPERTY OF CARRIER CORPORATION AND IS DELIVERED UPON THE EXPRESS CONDITION THAT THE CONTENTS WILL NOT BE DISCLOSED OR USED WITHOUT CARRIER CORPORATION'S WRITTEN CONSENT.  
 SUBMISSION OF THESE DRAWINGS OR DOCUMENTS DOES NOT CONSTITUTE PART PERFORMANCE OR ACCEPTANCE OF CONTRACT.

DATE 11/04/11	SUPERCEDES 03/07/11	30RAP010-150 ELECTRICAL	30RA555560	REV D
------------------	------------------------	-------------------------	------------	----------

# Summary Performance Report For Chiller 20 TR 460

Project: Chillers 2023  
Prepared By:

03/15/2023  
09:42a. m.



## AquaSnap™ Air-Cooled Scroll Chiller



### Unit Information

Tag Name:.....**Chiller 20 TR 460**  
 Model Number:.....**30RAP020**  
 Quantity:.....**1**  
 Manufacturing Source: **Charlotte, NC USA**  
 ASHRAE 90.1:.....**2013/2016, 2010, 2007**  
 Refrigerant:.....**R-410A**  
 Independent Refrigerant Circuits:.....**1**  
 Shipping Weight:.....**1124** lb  
 Operating Weight:.....**1133** lb  
 Refrigerant Weight (Circuit A):.....**15** lb  
 Unit Length:.....**89** in  
 Unit Width:.....**41** in  
 Unit Height:.....**67** in  
 Chiller Pressure Drop\*:.....**15.1** ft H2O  
 \*Use Chiller Pressure Drop for sizing pumps. This value includes losses due to chiller piping, fittings, 40 mesh factory supplied strainer and BPHX.

### Performance Information

Cooling Capacity:.....**18.84** Tons  
 Total Compressor Power:.....**18.88** kW  
 Total Fan Motor Power:.....**2.860** kW  
 Total Unit Power (without pump):.....**21.74** kW  
 Efficiency (without pump) (EER):.....**10.40** BTU/Wh  
 IPLV:.IP:.....**14.66** BTU/Wh

### Accessories and Installed Options

- Evaporator Heater
- Micro Channel
- Low Sound - Aero Acoustic Fans
- Single Point
- Fixed Speed Condenser Fan

### Electrical Information

Unit Voltage:.....**460-3-60** V-Ph-Hz  
 Connection Type:.....**Single Point**

### Evaporator Information

Fluid Type:.....**Fresh Water**  
 Fouling Factor:.....**0.000100** (hr-sqft-F)/BTU  
 Leaving Temperature:.....**44.00** °F  
 Entering Temperature:.....**54.00** °F  
 Fluid Flow:.....**45.06** gpm  
 Evaporator Pressure Drop\*:.....**12.3** ft H2O  
 \*Refer to Chiller Pressure Drop for sizing pumps.

Amps	Electrical Circuit 1	Electrical Circuit 2
MCA	46.1	---
MOCP	60.0	---
ICF	148.7	---
Rec Fuse Size	60.0	---

### Condenser Information

Altitude:.....**0.000** ft  
 Number of Fans:.....**2**  
 Total Condenser Fan Air Flow:.....**17,500** CFM  
 Entering Air Temperature:.....**95.0** °F

### Integrated Pump Information

No Pump Selected

Sound power measured in accordance with ANSI/AHRI Standard 370-2015.



Certified in accordance with the AHRI Air-Cooled Water-Chilling Packages Certification Program, which is based on AHRI Standard 550/590 (I-P) and AHRI Standard 551/591 (SI). Certified units may be found in the AHRI Directory at [www.ahridirectory.org](http://www.ahridirectory.org).

# Summary Performance Report For Chiller 20 TR 460

Project: Chillers 2023  
Prepared By:

03/15/2023  
09:42a. m.

### Unit Parameters

Tag Name:..... **Chiller 20 TR 460**  
 Model Number:..... **30RAP020**  
 Condenser Type:..... **Air Cooled**  
 Compressor Type:..... **Scroll**  
 Chiller Nameplate Voltage:..... **460-3-60** V-Ph-  
 Hz  
 Quantity:..... **1**  
 Manufacturing Source:..... **Charlotte, NC USA**  
 Refrigerant:..... **R-410A**  
 Shipping Weight:..... **1124** lb  
 Operating Weight:..... **1133** lb  
 Refrigerant Weight (Circuit A):..... **15** lb  
 Unit Length:..... **89** in  
 Unit Width:..... **41** in  
 Unit Height:..... **67** in

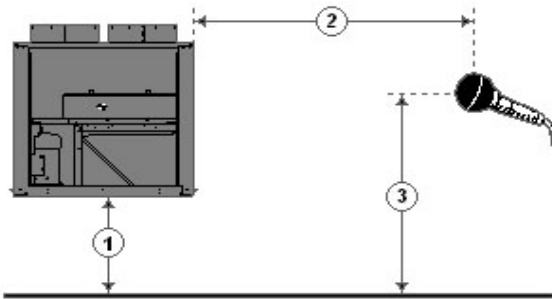

1 - Chiller Height Above Ground  
 2 - Horizontal Distance From Chiller to Receiver  
 3 - Receiver Height Above Ground  
 (See Note 3)

### Accessories and Installed Options

Evaporator Heater  
 Micro Channel  
 Low Sound - Aero Acoustic Fans

Single Point  
 Fixed Speed Condenser Fan

### Acoustic Information

**Table 1. A-Weighted Sound Power Levels (dB re 1 picowatt). See note #1.**

Octave Band Center Frequency, Hz	31	63	125	250	500	1k	2k	4k	8k	Overall
100% Load	---	59	72	78	83	83	82	77	70	88
75% Load	---	58	68	76	83	84	82	76	67	88
50% Load	---	56	68	76	82	83	81	75	66	88
25% Load	---	55	65	73	80	81	79	73	64	85

**Table 2. A-Weighted Sound Pressure Levels (dB re 20 micropascals) calculated based upon user defined input for dimensions 1, 2 and 3 as shown in above diagram. See note #2 and #3.**

Octave Band Center Frequency, Hz	31	63	125	250	500	1k	2k	4k	8k	Overall
100% Load	---	32	45	50	55	55	55	50	42	61
75% Load	---	31	40	49	55	56	54	49	40	61
50% Load	---	28	40	48	55	56	53	48	38	60
25% Load	---	28	37	46	52	53	51	46	37	58

- Notes: (1) Measurements performed in accordance with AHRI Standard 370-2015 for air cooled Chillers.  
 (2) Chiller is assumed to be a point source on a reflecting plane.  
 (3) Without user defined input, the default dimensions used to construct Table 2 are as follows:  
 1 - Chiller Height Above Ground = 0.0 ft  
 2 - Horizontal Distance From Chiller to Receiver = 30.0 ft  
 3 - Receiver Height Above Ground = 3.0 ft



**Please refer to Performance Output Summary or Detailed Performance Report for Acoustic information**



# Detailed Performance Summary For Chiller 20 TR 460

Project: Chillers 2023  
Prepared By:

03/15/2023  
09:42a. m.



## AquaSnap™ Air-Cooled Scroll Chiller



### Unit Information

Tag Name: **Chiller 20 TR 460**  
 Model Number: **30RAP020**  
 Condenser Type: **Air Cooled**  
 Compressor Type: **Scroll**  
 Nameplate Voltage: **460-3-60** V-Ph-Hz  
 Quantity: **1**  
 Manufacturing Source: **Charlotte, NC USA**  
 ASHRAE 90.1: **2013/2016, 2010, 2007**  
 Refrigerant: **R-410A**  
 Capacity Control Steps: **2**  
 Minimum Capacity: **50.00** %  
 Shipping Weight: **1124** lb  
 Operating Weight: **1133** lb  
 Refrigerant Weight (Circuit A): **15** lb  
 Unit Length: **89** in  
 Unit Width: **41** in  
 Unit Height: **67** in  
 Minimum Outdoor Operating Temp: **45.0** °F  
 Chiller Pressure Drop\*: **15.1** ft H2O

\*Use Chiller Pressure Drop for sizing pumps. This value includes losses due to chiller piping, fittings, 40 mesh factory supplied strainer and BPHX.

### Performance Information

Cooling Capacity: **18.84** Tons  
 Total Compressor Power: **18.88** kW  
 Total Fan Motor Power: **2.860** kW  
 Total Unit Power (without pump): **21.74** kW  
 Efficiency (without pump) (EER): **10.40** BTU/Wh

### Evaporator Information

Fluid Type: **Fresh Water**  
 Fouling Factor: **0.000100** (hr-sqft-F)/BTU  
 Leaving Temperature: **44.00** °F  
 Entering Temperature: **54.00** °F  
 Fluid Flow: **45.06** gpm  
 Fluid Flow Min: **23.00** gpm  
 Fluid Flow Max: **91.00** gpm

\*Refer to Chiller Pressure Drop for sizing pumps.  
 Evaporator Pressure Drop\*: **12.3** ft H2O  
 \*Refer to Chiller Pressure Drop for sizing pumps.

### Condenser Information

Altitude: **0.000** ft  
 Number of Fans: **2**  
 Total Condenser Fan Air Flow: **17,500** CFM  
 Entering Air Temperature: **95.0** °F

### Integrated Pump Information

No Pump Selected

### Accessories and Installed Options

Evaporator Heater  
 Micro Channel  
 Low Sound - Aero Acoustic Fans  
 Single Point  
 Fixed Speed Condenser Fan

### Electrical Information

Unit Voltage: **460-3-60** V-Ph-Hz  
 Connection Type: **Single Point**

Amps	Electrical Circuit 1	Electrical Circuit 2
MCA	46.1	---
MOCP	60.0	---
ICF	148.7	---
Rec Fuse Size	60.0	---

## Detailed Performance Summary For Chiller 20 TR 460

Project: Chillers 2023  
Prepared By:

03/15/2023  
09:42a. m.

### Integrated Part Load Value (AHLI)

IPLV:.....14.66 BTU/Wh

<b>Unit Performance</b>				
Percent of Full Load Capacity, %	100.00	75.00	50.00	25.00
Percent of Full Load Power, %	100.00	57.91	34.10	15.31
Unloading Sequence	A	A	A	A
Cooling Capacity, Tons	18.84	14.13	9.422	4.711
Total Unit Power, kW	21.74	12.59	7.414	3.328
Efficiency (EER), BTU/Wh	10.40	13.47	15.25	16.99
<b>Evaporator Data</b>				
Fluid Entering Temperature, °F	54.00	51.49	48.99	46.50
Fluid Leaving Temperature, °F	44.00	44.00	44.00	44.00
Fluid Flow Rate, gpm	45.06	45.06	45.06	45.06
Fouling Factor, (hr-sqft-F)/BTU	0.000100	0.000100	0.000100	0.000100
Pressure Drop, psi	6.54	6.57	6.60	6.63
<b>Condenser Data</b>				
Entering Air Temperature, °F	95.0	80.0	65.0	55.0

For some 75% operating points, the efficiency may be calculated at a condenser inlet air operating temperature as much as 0.8 degrees higher.

Sound power measured in accordance with ANSI/AHRI Standard 370-2015.



Certified in accordance with the AHRI Air-Cooled Water-Chilling Packages Certification Program, which is based on AHRI Standard 550/590 (I-P) and AHRI Standard 551/591 (SI). Certified units may be found in the AHRI Directory at [www.ahrirectory.org](http://www.ahrirectory.org).

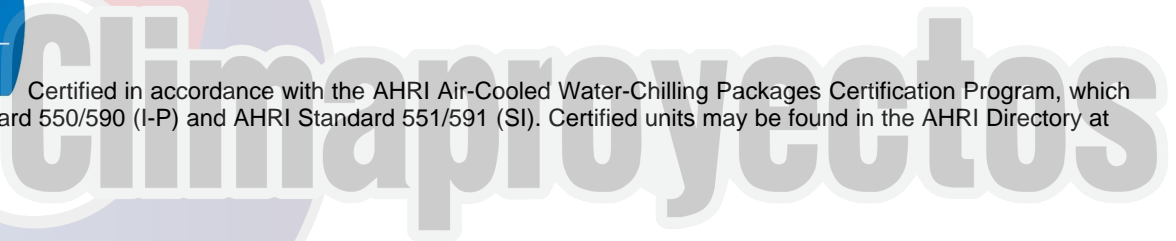

# Detailed Performance Summary For Chiller 20 TR 460

Project: Chillers 2023  
Prepared By:

03/15/2023  
09:42a. m.

### Unit Parameters

Tag Name:.....**Chiller 20 TR 460**  
 Model Number:.....**30RAP020**  
 Condenser Type:.....**Air Cooled**  
 Compressor Type:.....**Scroll**  
 Chiller Nameplate Voltage:.....**460-3-60** V-Ph-  
 Hz  
 Quantity:.....**1**  
 Manufacturing Source:.....**Charlotte, NC USA**  
 Refrigerant:.....**R-410A**  
 Shipping Weight:.....**1124** lb  
 Operating Weight:.....**1133** lb  
 Refrigerant Weight (Circuit A):.....**15** lb  
 Unit Length:.....**89** in  
 Unit Width:.....**41** in  
 Unit Height:.....**67** in

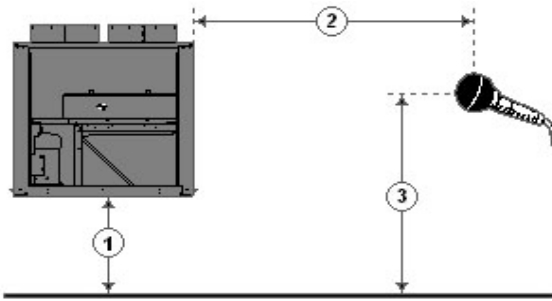

1 - Chiller Height Above Ground  
 2 - Horizontal Distance From Chiller to Receiver  
 3 - Receiver Height Above Ground  
 (See Note 3)

### Accessories and Installed Options

Evaporator Heater  
 Micro Channel  
 Low Sound - Aero Acoustic Fans

Single Point  
 Fixed Speed Condenser Fan

### Acoustic Information

**Table 1. A-Weighted Sound Power Levels (dB re 1 picowatt). See note #1.**

Octave Band Center Frequency, Hz	31	63	125	250	500	1k	2k	4k	8k	Overall
100% Load	---	59	72	78	83	83	82	77	70	88
75% Load	---	58	68	76	83	84	82	76	67	88
50% Load	---	56	68	76	82	83	81	75	66	88
25% Load	---	55	65	73	80	81	79	73	64	85

**Table 2. A-Weighted Sound Pressure Levels (dB re 20 micropascals) calculated based upon user defined input for dimensions 1, 2 and 3 as shown in above diagram. See note #2 and #3.**

Octave Band Center Frequency, Hz	31	63	125	250	500	1k	2k	4k	8k	Overall
100% Load	---	32	45	50	55	55	55	50	42	61
75% Load	---	31	40	49	55	56	54	49	40	61
50% Load	---	28	40	48	55	56	53	48	38	60
25% Load	---	28	37	46	52	53	51	46	37	58

- Notes: (1) Measurements performed in accordance with AHRI Standard 370-2015 for air cooled Chillers.  
 (2) Chiller is assumed to be a point source on a reflecting plane.  
 (3) Without user defined input, the default dimensions used to construct Table 2 are as follows:  
 1 - Chiller Height Above Ground = 0.0 ft  
 2 - Horizontal Distance From Chiller to Receiver = 30.0 ft  
 3 - Receiver Height Above Ground = 3.0 ft