



SUBMITTAL

Project

Chillers 2023

Date

lunes, 13 de marzo de 2023

General Contractor

Mechanical Contractor

Mechanical Engineer

A large, semi-transparent watermark logo for "Climaproyectos" is positioned on the left side of the page. It features a circular graphic with a red arrow pointing up and a blue arrow pointing down, forming a cycle. The word "Climaproyectos" is written in a large, bold, grey sans-serif font across the middle of the graphic.

Climaproyectos

Table Of Contents

Project: Chillers 2023
Prepared By:

03/16/2023
10:52a. m.

Unit Report.....	3
Certified Drawing.....	4
Field Wiring Diagram.....	6
Acoustic Summary.....	10
Detailed Performance Report.....	11



Unit Report For Chiller 120 TR 460

Project: Chillers 2023
 Prepared By:

03/16/2023
 10:52a. m.

Unit Information

Tag Name:.....**Chiller 120 TR 460**
 Model Number:.....**30RB120**
 Condenser Type:.....**Air Cooled**
 Compressor Type:.....**Scroll**
 Nameplate Voltage:.....**460-3-60** V-Ph-Hz
 Quantity:.....**1**
 Manufacturing Source:.....**Charlotte, NC USA**
 Refrigerant:.....**R410A**
 Independent Refrigerant Circuits:.....**2**
 Capacity Control Steps:.....**5**
 Minimum Capacity:.....**20.0** %
 Shipping Weight:.....**6744** lb
 Operating Weight:.....**7119** lb
 Unit Length:.....**189** in
 Unit Width:.....**89** in
 Unit Height:.....**90** in

Accessories and Installed Options

Freeze Protection
 Micro Channel
 Single Point
 Coil Trim Panels (Header side only)

Chiller Warranty Information (Note: for US & Canada only)

First Year - Parts Only (Standard)

Ordering Information

Part Number	Description	Quantity
30RBX12064-L---3	Packaged Chiller	1
	Base Unit	
	Freeze Protection	
	Micro Channel	
	Single Point	
	Coil Trim Panels (Header side only)	



Certified Drawing for Chiller 120 TR 460

Project: Chillers 2023
Prepared By:

03/16/2023
10:52a. m.



Certified Drawing for Chiller 120 TR 460

Project: Chillers 2023
Prepared By:

03/16/2023
10:52a. m.

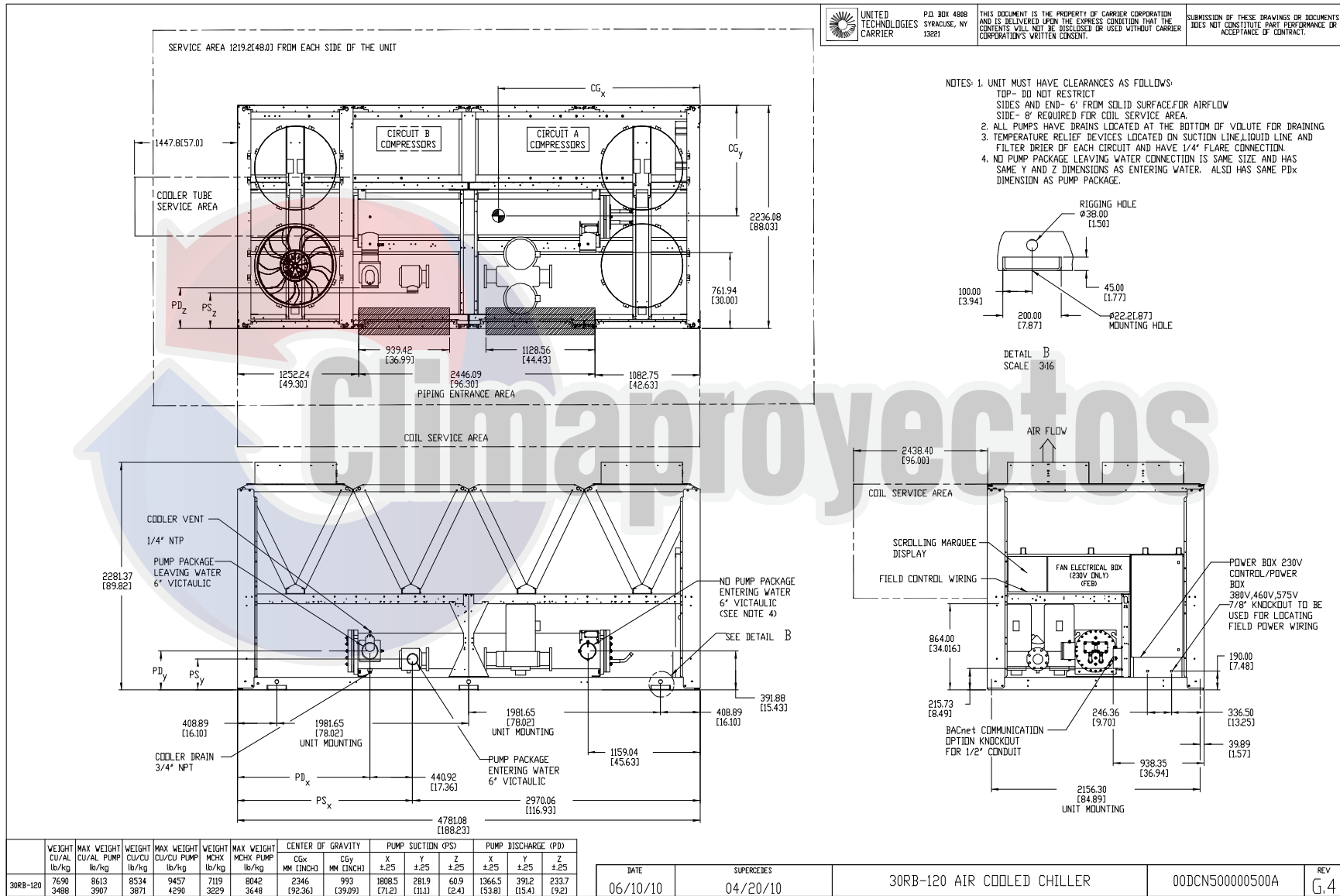

Field Wiring Diagram for Chiller 120 TR 460

Project: Chillers 2023
Prepared By:

03/16/2023
10:52a. m.

NOTES:

1. FACTORY WIRING IS IN ACCORDANCE WITH UL 1995 STANDARDS. FIELD MODIFICATIONS OR ADDITIONS MUST BE IN COMPLIANCE WITH ALL APPLICABLE CODES.
2. WIRING FOR MAIN FIELD SUPPLY MUST BE RATED 75C MINIMUM. USE COPPER FOR ALL UNITS. INCOMING WIRE SIZE RANGE FOR THE TERMINAL BLOCK IS #4 AWG TO 500 KCMIL. INCOMING WIRE SIZE RANGE OF NON-FUSED DISCONNECT WITH MCA UP TO 599.9 AMPS IS 3/0 TO 500 KCMIL. INCOMING WIRE SIZE RANGE OF NON-FUSED DISCONNECT WITH MCA FROM 600 TO 799.9 AMPS IS 1/0 TO 500 KCMIL. INCOMING WIRE SIZE RANGE OF NON-FUSED DISCONNECT WITH MCA FROM 800 TO 1199.9 AMPS IS 250 KCMIL TO 500 KCMIL.
3. TERMINALS 9 AND 10 OF TB5 ARE FOR FIELD EXTERNAL CONNECTIONS FOR REMOTE ON-OFF. THE CONTACTS MUST BE RATED FOR DRY CIRCUIT APPLICATION CAPABLE OF HANDLING A 24VAC LOAD UP TO 50 MA.
4. TERMINALS 1 AND 2 OF TB5 ARE FOR EXTERNAL CONNECTIONS OF CHILLED WATER PUMP INTERLOCK. THE CONTACTS MUST BE RATED FOR DRY CIRCUIT APPLICATION CAPABLE OF HANDLING A 24VAC LOAD UP TO 50 MA.
5. TERMINALS 11 AND 13 OF TB5 ARE FOR CONTROL OF CHILLED WATER PUMP1 (PMP1) STARTER. TERMINALS 13 AND 15 OF TB5 ARE FOR CONTROL OF CHILLED WATER PUMP2 (PMP2) STARTER. THE MAXIMUM LOAD ALLOWED FOR THE CHILLED WATER PUMP IS 5 VA SEALED, 10 VA INRUSH AT 24V. FIELD POWER SUPPLY IS NOT REQUIRED.
6. FOR CONTROL OF CHILLED WATER PUMPS, A SET OF NORMALLY OPEN CONTACTS RATED FOR DRY CIRCUIT APPLICATION MUST BE SUPPLIED FROM FIELD SUPPLIED PUMP STARTER RELAY. CONNECT CONTACTS TO VIOLET AND PINK WIRES IN HARNESS FROM MAIN BASE BOARD CHANNEL 18. WIRES IN HARNESS ARE MARKED PMP1-13 AND PMP1-14.
7. TERMINALS 12 AND 13 OF TB5 ARE FOR A ALARM RELAY. THE MAXIMUM LOAD ALLOWED FOR THE ALARM RELAY IS 10 VA SEALED, 25 VA INRUSH AT 24V. FIELD POWER SUPPLY IS NOT REQUIRED.
8. MAKE APPROPRIATE CONNECTIONS TO TB6 AS SHOWN FOR ENERGY MANAGEMENT BOARD OPTIONS. THE CONTACTS FOR OCCUPANCY OVERRIDE, DEMAND LIMIT AND ICE BONE OPTIONS MUST BE RATED FOR DRY CIRCUIT APPLICATION CAPABLE OF HANDLING A 24VAC LOAD UP TO 50 MA.
9. J3 - 24 AND 25 OF EMM BOARD ARE FOR RUN RELAY AND SHUTDOWN RELAY. THE MAXIMUM LOAD ALLOWED FOR THE RUN AND SHUTDOWN RELAY IS 10 VA SEALED, 25 VA INRUSH AT 24V. FIELD POWER SUPPLY IS NOT REQUIRED.

- A - ALARM
- PMP1- CHILLED WATER PUMP INTERLOCK
- CWP - CHILLED WATER PUMP
- EMM - ENERGY MANAGEMENT
- SHD R- SHUTDOWN RELAY
- RUN R- RUN RELAY
- MLV - MINIMUM LOAD VALVE
- TB - TERMINAL BLOCK
- FIELD POWER WIRING
- - - FIELD CONTROL WIRING

SIZE	STD UNIT
315A,B	160
330B	
330A	
345A,B	170
360B	
360A	190
390A,B	

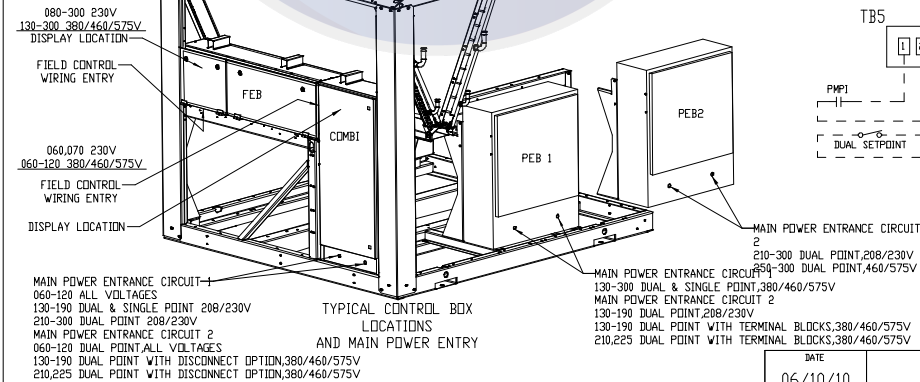

UNITED TECHNOLOGIES CARRIER P.O. BOX 4888 SYRACUSE, NY 13221
THIS DOCUMENT IS THE PROPERTY OF CARRIER CORPORATION AND IS DELIVERED UPON THE EXPRESS CONDITION THAT THE CONTENTS WILL NOT BE DISCLOSED OR USED WITHOUT CARRIER CORPORATION'S WRITTEN CONSENT.
SUBMISSION OF THESE DRAWINGS OR DOCUMENTS DOES NOT CONSTITUTE PART PERFORMANCE OR ACCEPTANCE OF CONTRACT.

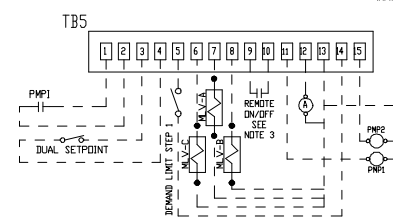
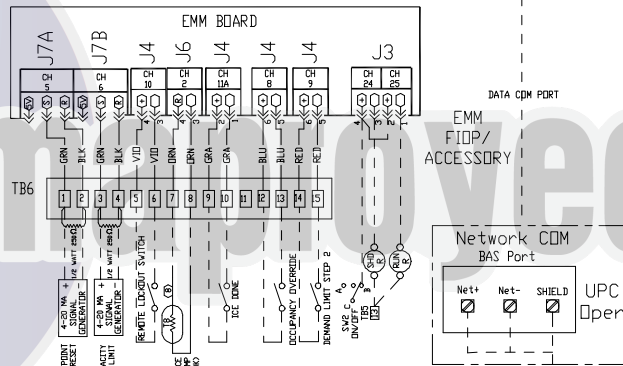
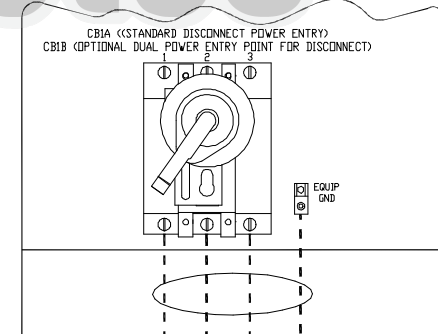
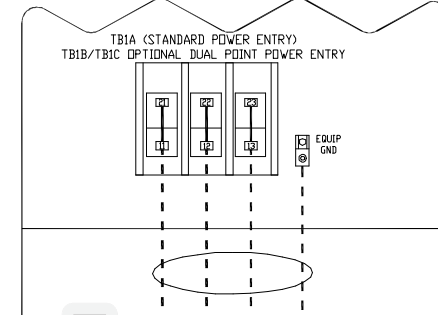
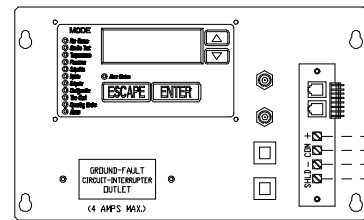

DATE	SUPERCEDES	30RB060-390 AIR-COOLED AQUASNAP CHILLER	00DCN500001300A	REV
06/10/10	03/09/09			G.2

Summary Performance Report For Chiller 120 TR 460

Project: Chillers 2023
Prepared By:

03/16/2023
10:52a. m.



AquaSnap™ Air-Cooled Scroll Chiller



Unit Information

Tag Name: **Chiller 120 TR 460**
 Model Number: **30RB120**
 Quantity: **1**
 Manufacturing Source: **Charlotte, NC USA**
 ASHRAE 90.1: **2013/2016, 2010, 2007**
 Refrigerant: **R-410A**
 Independent Refrigerant Circuits: **2**
 Shipping Weight: **6744** lb
 Operating Weight: **7119** lb
 Refrigerant Weight (Circuit A): **43** lb
 Refrigerant Weight (Circuit B): **57** lb
 Unit Length: **189** in
 Unit Width: **89** in
 Unit Height: **90** in

Accessories and Installed Options

Freeze Protection
 Micro Channel
 Single Point
 Coil Trim Panels (Header side only)

Electrical Information

Unit Voltage: **460-3-60** V-Ph-Hz
 Connection Type: **Single Point**
 Minimum Voltage: **414** Volts
 Maximum Voltage: **506** Volts

Amps	Electrical Circuit 1	Electrical Circuit 2
MCA	256.2	---
MOCP	300.0	---
ICF	469.6	---
Rec Fuse Size	300.0	---

Evaporator Information

Fluid Type: **Fresh Water**
 Fouling Factor: **0.000100** (hr-sqft-F)/BTU
 Leaving Temperature: **44.00** °F
 Entering Temperature: **54.00** °F
 Fluid Flow: **282.1** gpm
 Pressure Drop: **10.8** ft H2O

Condenser Information

Altitude: **0.000** ft
 Number of Fans: **7**
 Total Condenser Fan Air Flow: **86,800** CFM
 Entering Air Temperature: **95.0** °F

Integrated Pump Information

No Pump Selected

Performance Information

Cooling Capacity: **118.0** Tons
 Total Compressor Power: **119.7** kW
 Total Fan Motor Power: **18.06** kW
 Total Unit Power (without pump): **137.7** kW
 Efficiency (without pump) (EER): **10.28** BTU/Wh
 IPLV: IP: **13.82** BTU/Wh

Sound power measured in accordance with ANSI/AHRI Standard 370-2015.



Certified in accordance with the AHRI Air-Cooled Water-Chilling Packages Certification Program, which is based on AHRI Standard 550/590 (I-P) and AHRI Standard 551/591 (SI). Certified units may be found in the AHRI Directory at www.ahrirectory.org.

Summary Performance Report For Chiller 120 TR 460

Project: Chillers 2023
Prepared By:

03/16/2023
10:52a. m.



Summary Performance Report For Chiller 120 TR 460

Project: Chillers 2023
Prepared By:

03/16/2023
10:52a. m.

Unit Parameters

Tag Name:..... **Chiller 120 TR 460**
 Model Number:..... **30RB120**
 Condenser Type:..... **Air Cooled**
 Compressor Type:..... **Scroll**
 Chiller Nameplate Voltage:..... **460-3-60** V-Ph-
 Hz
 Quantity:..... **1**
 Manufacturing Source:..... **Charlotte, NC USA**
 Refrigerant:..... **R-410A**
 Shipping Weight:..... **6744** lb
 Operating Weight:..... **7119** lb
 Refrigerant Weight (Circuit A):..... **43** lb
 Refrigerant Weight (Circuit B):..... **57** lb
 Unit Length:..... **189** in
 Unit Width:..... **89** in
 Unit Height:..... **90** in

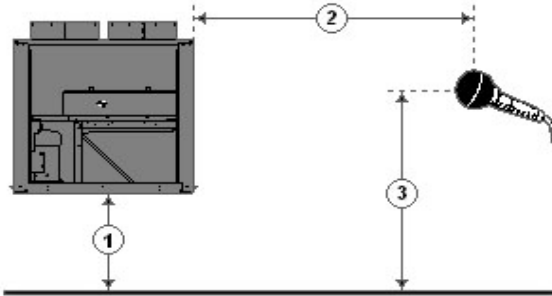

1 - Chiller Height Above Ground
 2 - Horizontal Distance From Chiller to Receiver
 3 - Receiver Height Above Ground
 (See Note 3)

Accessories and Installed Options

Freeze Protection
Micro Channel

Single Point
Coil Trim Panels (Header side only)

Acoustic Information

Table 1. A-Weighted Sound Power Levels (dB re 1 picowatt). See note #1.

Octave Band Center Frequency, Hz	31	63	125	250	500	1k	2k	4k	8k	Overall
100% Load	---	68	80	87	93	98	92	89	81	101
75% Load	---	68	80	87	93	98	92	88	80	100
50% Load	---	67	80	87	92	97	91	88	79	100
25% Load	---	65	80	85	90	94	89	86	76	97

Table 2. A-Weighted Sound Pressure Levels (dB re 20 micropascals) calculated based upon user defined input for dimensions 1, 2 and 3 as shown in above diagram. See note #2 and #3.

Octave Band Center Frequency, Hz	31	63	125	250	500	1k	2k	4k	8k	Overall
100% Load	---	40	51	59	65	70	64	61	52	72
75% Load	---	40	51	59	65	69	64	60	52	72
50% Load	---	39	51	58	64	69	63	59	51	71
25% Load	---	37	52	57	62	66	61	58	48	69

- Notes: (1) Measurements performed in accordance with AHRI Standard 370-2015 for air cooled Chillers.
 (2) Chiller is assumed to be a point source on a reflecting plane.
 (3) Without user defined input, the default dimensions used to construct Table 2 are as follows:
 1 - Chiller Height Above Ground = 0.0 ft
 2 - Horizontal Distance From Chiller to Receiver = 30.0 ft
 3 - Receiver Height Above Ground = 3.0 ft

Please refer to Performance Output Summary or Detailed Performance Report for Acoustic information



Detailed Performance Summary For Chiller 120 TR 460

Project: Chillers 2023
Prepared By:

03/16/2023
10:52a. m.



AquaSnap™ Air-Cooled Scroll Chiller



Unit Information

Tag Name:..... **Chiller 120 TR 460**
 Model Number:..... **30RB120**
 Condenser Type:..... **Air Cooled**
 Compressor Type:..... **Scroll**
 Nameplate Voltage:..... **460-3-60** V-Ph-Hz
 Quantity:..... **1**
 Manufacturing Source:..... **Charlotte, NC USA**
 ASHRAE 90.1:..... **2013/2016, 2010, 2007**
 Refrigerant:..... **R-410A**
 Capacity Control Steps:..... **5**
 Minimum Capacity:..... **20.00** %
 Shipping Weight:..... **6744** lb
 Operating Weight:..... **7119** lb
 Refrigerant Weight (Circuit A):..... **43** lb
 Refrigerant Weight (Circuit B):..... **57** lb
 Unit Length:..... **189** in
 Unit Width:..... **89** in
 Unit Height:..... **90** in
 Minimum Outdoor Operating Temp:..... **32.0** °F

Condenser Information

Altitude:..... **0.000** ft
 Number of Fans:..... **7**
 Total Condenser Fan Air Flow:..... **86,800** CFM
 Entering Air Temperature:..... **95.0** °F

Integrated Pump Information

No Pump Selected

Accessories and Installed Options

Freeze Protection
 Micro Channel
 Single Point
 Coil Trim Panels (Header side only)

Electrical Information

Unit Voltage:..... **460-3-60** V-Ph-Hz
 Connection Type:..... **Single Point**
 Minimum Voltage:..... **414** Volts
 Maximum Voltage:..... **506** Volts

Performance Information

Cooling Capacity:..... **118.0** Tons
 Total Compressor Power:..... **119.7** kW
 Total Fan Motor Power:..... **18.06** kW
 Total Unit Power (without pump):..... **137.7** kW
 Efficiency (without pump) (EER):..... **10.28** BTU/Wh

Amps	Electrical Circuit 1	Electrical Circuit 2
MCA	256.2	---
MOCP	300.0	---
ICF	469.6	---
Rec Fuse Size	300.0	---

Evaporator Information

Fluid Type:..... **Fresh Water**
 Fouling Factor:..... **0.000100** (hr-sqft-F)/BTU
 Leaving Temperature:..... **44.00** °F
 Entering Temperature:..... **54.00** °F
 Fluid Flow:..... **282.1** gpm
 Fluid Flow Min:..... **144.0** gpm
 Fluid Flow Max:..... **576.0** gpm
 Pressure Drop:..... **10.8** ft H2O

Detailed Performance Summary For Chiller 120 TR 460

Project: Chillers 2023
Prepared By:

03/16/2023
10:52a. m.

Integrated Part Load Value (AHRI)

IPLV:.....13.82 BTU/Wh

Unit Performance				
Percent of Full Load Capacity, %	100.00	75.00	50.00	25.00
Percent of Full Load Power, %	100.00	59.03	36.30	16.61
Unloading Sequence	B	B	B	B
Cooling Capacity, Tons	118.0	88.50	59.00	29.50
Total Unit Power, kW	137.7	81.29	50.00	22.87
Efficiency (EER), BTU/Wh	10.28	13.06	14.16	15.48
Evaporator Data				
Fluid Entering Temperature, °F	54.00	51.49	48.99	46.50
Fluid Leaving Temperature, °F	44.00	44.00	44.00	44.00
Fluid Flow Rate, gpm	282.1	282.1	282.1	282.1
Fouling Factor, (hr-sqft-F)/BTU	0.000100	0.000100	0.000100	0.000100
Pressure Drop, psi	4.70	4.72	4.74	4.77
Condenser Data				
Entering Air Temperature, °F	95.0	80.0	65.0	55.0

Sound power measured in accordance with ANSI/AHRI Standard 370-2015.



Certified in accordance with the AHRI Air-Cooled Water-Chilling Packages Certification Program, which is based on AHRI Standard 550/590 (I-P) and AHRI Standard 551/591 (SI). Certified units may be found in the AHRI Directory at www.ahridirectory.org.

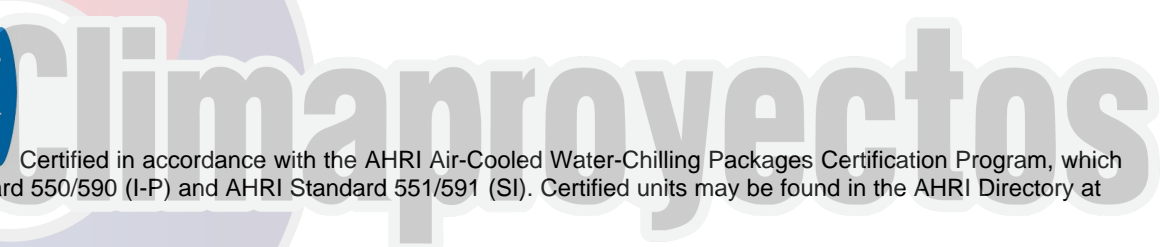

Detailed Performance Summary For Chiller 120 TR 460

Project: Chillers 2023
Prepared By:

03/16/2023
10:52a. m.

Unit Parameters

Tag Name:.....Chiller 120 TR 460
 Model Number:.....30RB120
 Condenser Type:.....Air Cooled
 Compressor Type:.....Scroll
 Chiller Nameplate Voltage:.....460-3-60 V-Ph-
 Hz
 Quantity:.....1
 Manufacturing Source:.....Charlotte, NC USA
 Refrigerant:.....R-410A
 Shipping Weight:.....6744 lb
 Operating Weight:.....7119 lb
 Refrigerant Weight (Circuit A):.....43 lb
 Refrigerant Weight (Circuit B):.....57 lb
 Unit Length:.....189 in
 Unit Width:.....89 in
 Unit Height:.....90 in

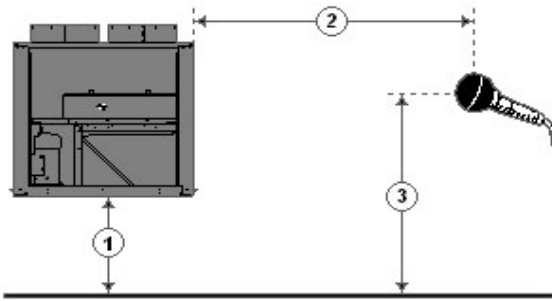

1 - Chiller Height Above Ground
 2 - Horizontal Distance From Chiller to Receiver
 3 - Receiver Height Above Ground
 (See Note 3)

Accessories and Installed Options

Freeze Protection
 Micro Channel
 Single Point
 Coil Trim Panels (Header side only)

Acoustic Information

Table 1. A-Weighted Sound Power Levels (dB re 1 picowatt). See note #1.

Octave Band Center Frequency, Hz	31	63	125	250	500	1k	2k	4k	8k	Overall
100% Load	---	68	80	87	93	98	92	89	81	101
75% Load	---	68	80	87	93	98	92	88	80	100
50% Load	---	67	80	87	92	97	91	88	79	100
25% Load	---	65	80	85	90	94	89	86	76	97

Table 2. A-Weighted Sound Pressure Levels (dB re 20 micropascals) calculated based upon user defined input for dimensions 1, 2 and 3 as shown in above diagram. See note #2 and #3.

Octave Band Center Frequency, Hz	31	63	125	250	500	1k	2k	4k	8k	Overall
100% Load	---	40	51	59	65	70	64	61	52	72
75% Load	---	40	51	59	65	69	64	60	52	72
50% Load	---	39	51	58	64	69	63	59	51	71
25% Load	---	37	52	57	62	66	61	58	48	69

- Notes: (1) Measurements performed in accordance with AHRI Standard 370-2015 for air cooled Chillers.
 (2) Chiller is assumed to be a point source on a reflecting plane.
 (3) Without user defined input, the default dimensions used to construct Table 2 are as follows:
 1 - Chiller Height Above Ground = 0.0 ft
 2 - Horizontal Distance From Chiller to Receiver = 30.0 ft
 3 - Receiver Height Above Ground = 3.0 ft