

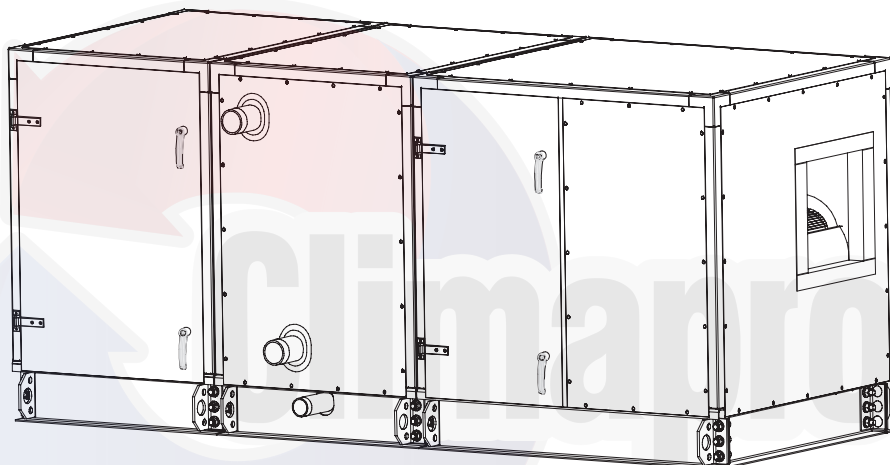

# Product Data

# Aero® 39MN, MW 03-110 Indoor and Weathertight Outdoor Air Handlers

1,500 to 60,500 Nominal Cfm



39MN INDOOR UNIT

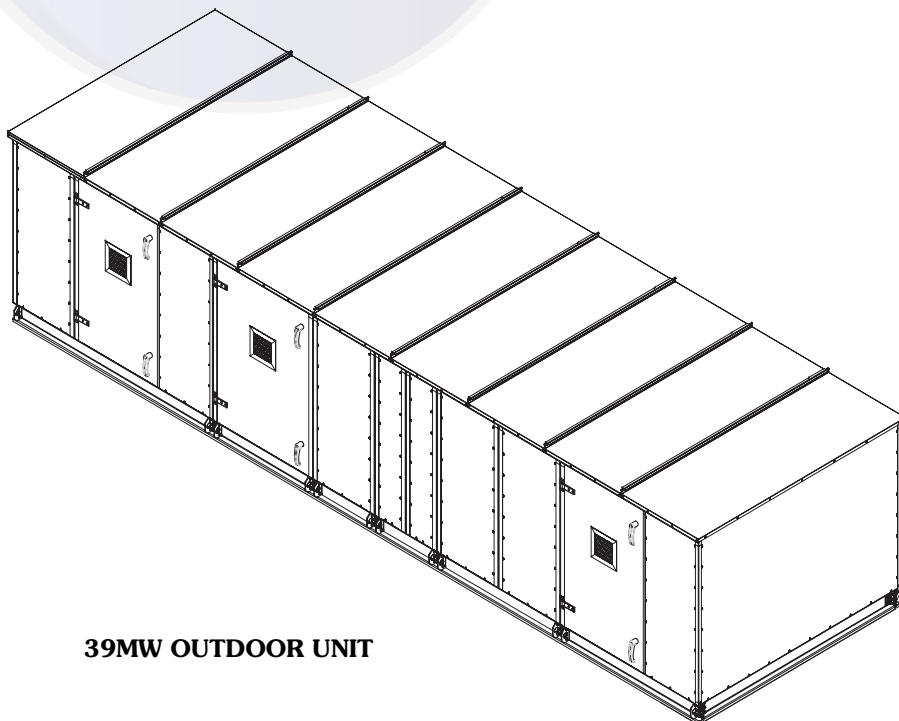

39MW OUTDOOR UNIT

Carrier's 39M air handlers offer:

- Shrink-wrapped units for complete protection while in transit
- Factory-supplied variable frequency drives that are programmed and started up at the factory
- Sealed panel double-wall R-13 insulation system
- Stacked indoor unit configurations for application versatility and maximum space utilization
- Outdoor weathertight cabinets have sloped roofs to reduce standing water, and are gasketed in all critical areas.
- Factory-installed integral face and bypass coils for extreme conditions
- Factory-installed humidifiers for precise indoor climate conditioning
- Factory-installed indirect fired gas heating sections with a minimum 10:1 turndown
- Factory-installed, AHRI 1060 certified ERV wheel sections
- Available direct drive fans and fan arrays
- Available factory-mounted controls, starters, disconnects and variable frequency drives
- **AHUBuilder®** software for easy unit selection
- Optional pre-painted unit exterior
- Optional Agion® anti-microbial coated panel interior
- Optional factory-installed UV-C germicidal lamps

## Features/Benefits

**The Aero 39M air handler is the only unit on the market that practically installs itself.**

### Easy installation

Frames, corners and base rails of the 39M air handler are all easily disassembled and reassembled in minutes with as little as 3 standard tools. Carrier's 39M units can be ordered with shipping splits, which speed section to section assembly.

# Features/Benefits (cont)



## Redefining flexibility

Standard stacked fans and exhaust box sections reduce the footprint of the unit and ensure economical use of building space. Accessibility is required from only one side of the unit, increasing location options. This may result in floor space savings of 20% over competitive units.

The use of non-staggered coils allows flat and cartridge style filter sections to maintain face velocities of 500 fpm or less at nominal airflow. Low velocity angle filtration sections typically have velocities of 350 fpm or less.

## Custom engineered for durability and longevity

Sealed panel double-wall R-13 insulation system means no insulation is exposed to the airstream. All panels are easily removed in one piece for cleaning or access to all components. Hinged doors are also available.

Internally mounted motors and drives operate in a clean environment, giving longer life to motor and belts. Belts and drives are factory installed and aligned.

Factory installed and wired variable frequency drives, bypasses, motor starters and disconnects are easily available at the click of a button with **AHUBuilder**<sup>®</sup> software.

Internal isolation of the fan assembly reduces vibration and eliminates the need for unit isolation at installation time. Fan and motor bearings are mounted on a corrosion-resistant steel frame, which is isolated from the outer casing with 2-in. deflection, factory-installed spring isolators and a vibration-absorbent fan discharge seal.

## Easy service and maintenance

Panels are easily removed in one piece for cleaning or access to all components. Hinged doors are also available.

## Optimized performance

Not only does **AHUBuilder** software help define the footprint of your custom air handler, it also suggests an optimally selected fan based on your performance criteria. Choose from airfoil, forward-curved, belt-drive plenum, direct-drive plenum, and plenum fan arrays based on first cost and performance requirements. As standard, pillow-block bearings are rated at 200,000 hours average life ( $L_{50}$ ) in all 03-110 size airfoil, forward-curved,

and belt-drive plenum fans. Optionally, bearings rated at 500,000 hours average life ( $L_{50}$ ) are available.

Standard low-leak dampers in mixing box sections seal tightly. Optional high-efficiency airfoil blade dampers are also available.

Exclusive Carrier coil surface results in efficient heat transfer. Since less heating and cooling fluid is circulated, pumping costs are reduced.

## Provisions for indoor air quality (IAQ) requirements

### Filtration flexibility includes

- 2-in. or 4-in. flat filters
- 2-in. or 4-in. angle filters
- Side loading 12-in. bag/cartridge filters with 2-in. prefilters
- Side loading 30-in. bag/cartridge filters with 2-in. prefilters
- Face loading bag/cartridge filters without prefilters
- HEPA face loading bag/cartridge filters without prefilters

### Optional galvanized or stainless steel coil drain pan

— Drain pan is sloped toward the drain to remove condensate completely. This eliminates build-up of stagnant water during shutdown periods and keeps the air handler free of odors and bacteria. Stainless steel provides an easy-to-clean surface that resists corrosion.

### UV-C germicidal lamps

- Energy Savings: Lowers energy costs by improving HVAC system heat transfer and increasing net cooling capacity.
- Maintenance Savings: Continuously cleans coils, drain pans, plenums, and ducts, reducing or eliminating manual cleaning and the use of harmful chemicals.
- Improved IAQ: Reduces the spread of airborne microorganisms that trigger allergy and asthma symptoms and reduces the spread of bacteria and viruses that can cause infectious diseases.
- Water Conservation: Reclaiming clean condensate for tower makeup, irrigation or gray water flushing reduces water and waste water costs.
- Rapid Return on Investment: Offers a return on investment in less than 2 years.
- LEED<sup>†</sup> Rating System Contribution: UV-C lamp may contribute to points in one or more areas of the

U.S. Green Building Council's LEED rating system.

## Extensive AHUBuilder software optimized coil selection

The 39M air handlers have a wide selection of coils to meet your application needs. All 39M coils have Carrier's high-performance coil surface; the coil tubes are mechanically expanded into the fins for improved fin bonding and peak thermal transfer. All vent and drain connections are accessible from outside the cabinet. Optional copper fins and stainless steel casings are available for all coils.

**Chilled water coils** — These coils have headers precisely sized to minimize water pressure loss. Chilled water coils are manufactured of 1/2-in. OD (5/8-in. OD optional) copper tubes with aluminum plate fins (8, 11, or 14 fins per in.). Copper and e-coated fins are optional. Large, medium and bypass face area coils are available in 4, 6, 8, or 10 rows. Steel coil connectors with male pipe thread are standard.

**Direct expansion coils** — There is no need to guess when it comes to direct expansion coil performance.

**AHUBuilder**<sup>®</sup> is the only selection program that crossplots the evaporator and condensing unit performance to show the true system capacity. Coils are available in large or medium face area, with 4, 6, or 8 rows. The tubes are of 1/2-in. OD copper with aluminum-plate fins, and 8, 11, or 14 fins per inch. Copper and e-coated fins are available as an option. Choose from quarter, half, full, or double circuits. Most direct expansion coils have at least two splits allowing you to match a coil with one or two condensing units for independent refrigerant systems.

**Hot water coils** — Carrier's hot water coils are designed to provide heating capability for a complete range of applications, at a working pressure of 300 psig at 200 F. Hot water coils are offered in 1, 2 or 4 rows, with fin spacings of 8, 11, or 14 fins per inch. Coils have aluminum plate fins with copper tubes (copper and e-coat fins available). Hot water coils are available with large, medium, small or bypass face areas.

**Steam coils** — The 39M inner distributing tube (IDT) steam coils are designed for a working pressure of 175 psig at 400 F. The plate-fin steam coil is available in one row 1-in. OD

copper tubes, with 6, 9, or 12 aluminum fins per inch. Steam coils are available with large, medium, small or bypass face areas, and are sloped to drain condensate. Steam coils are especially suited to applications where sub-freezing air enters the air-handling unit, or where uniformity of leaving-air temperature is required.

**Integral face and bypass coil section** — Carrier offers integral face and bypass (IFB) coils capable of maintaining a constant air volume within 5%, constant leaving-air temperature as entering-air conditions vary, and mixing of leaving-air temperatures within 3 ft downstream with a maximum variance in air temperature of 5° F, regardless of damper position.

**Electric heat coil** — The 39M electric heat coils may be ordered for factory installation into the electric heat section. Units with electric heat are designed in accordance by UL (Underwriters Laboratories) 1995.

**Indirect fired gas heating** — Gas-fired heating sections are available in 409 and 304L stainless steel tubular construction for use with natural gas or

propane. Our gas-fired heating sections allow a minimum of 10:1 and up to a maximum of 60:1 electronic modulation depending on unit size and gas heat configuration.

**Components for customizing standard units**

**Humidifiers** — The 39M humidifiers use insulated direct steam discharge uprights constructed of 316 stainless steel, supported by horizontal manifolds of the same material. Steam can be delivered to the humidifier at atmospheric pressure from a steam generator or up to 60 psi plant steam.

**Face and bypass components with bypass cooling and heating coils** — Four different component combinations provide controlled mixing of bypass air and conditioned air. These include bypass heating, bypass cooling, bypass heating/cooling, and bypass cooling/heating in either internal or external bypass mode.

**Blow-thru coil** — These components are available for single-duct, dual-duct, and multizone applications requiring cooling only or both heating and

cooling. The diffuser plate is integrally mounted to the fan discharge in blow-thru applications.

**Optional air mixer** — When installed immediately downstream from a mixing box or filter mixing box, the air mixer section blends airstreams with different temperatures to within a range of 6° F. The mixer section reduces air stratification and ensures that exiting blended air has a uniform velocity. Blended air helps to reduce the possibility of coil freeze-up and equalizes coil discharge temperatures.

**Carrier factory-installed Direct Digital Controls** — Carrier offers a wide range of Direct Digital Controls (DDC) to meet your application needs. Contact your Carrier sales representative for details.

**Custom design flexibility** — Options not shown in the Product Data or **AHUBuilder**® software may be available through the factory design enhancement center. Contact your local Carrier sales representative for details.

**AGION ANTI-MICROBIAL COATING**

**How it works:**  
 The Agion antimicrobial compound is blended into a paint system, which resides in zeolite's open molecular structure. When ambient moisture is present, the zeolite acts as an "ion pump," slowly releasing silver ions into the air. When the silver ions come into contact with bacteria and other microbes, their chemical interaction disrupts electron transfer and respiration, suppressing microbe growth on the air handler. As the air becomes more humid (and the more favorable for microbial growth), more silver is released. However, there is a maximum release rate, so even under very wet conditions, the silver ions are released slowly, for long-term protection.

## Table of contents

	Page
Features/Benefits . . . . .	1-4
AHRI Certification . . . . .	5
Model Number Nomenclature . . . . .	5
Application Data . . . . .	6-17
Selection Procedure . . . . .	18,19
Dimensions . . . . .	20-44
Physical Data . . . . .	45-77
Guide Specifications . . . . .	78-109

# Features/Benefits (cont)



## 39M Features and Benefits

- **Robust casing:** 2 in. post and panelized construction allows panel to be removed while maintaining structural integrity.
- **Rigid design:** Panel construction maintains an industry leading linear deflection ratio of L/240 at  $\pm 8$  in. wg.
- **Antimicrobial prevention:** Since 2003, Carrier has offered an optional Agion panel coating that provides constant protection against antimicrobial growth with the continuous release of silver ions.
- **Service and access:** Weld-free design promotes panel removal and optimizes serviceability of the unit.
- **Sound performance:** Sound data for fan inlet, discharge, and casing tested and certified in compliance with AHRI 260 at design and part load conditions where applicable.
- **Factory-mounted and tested control offering:** For convenience, available single point power.

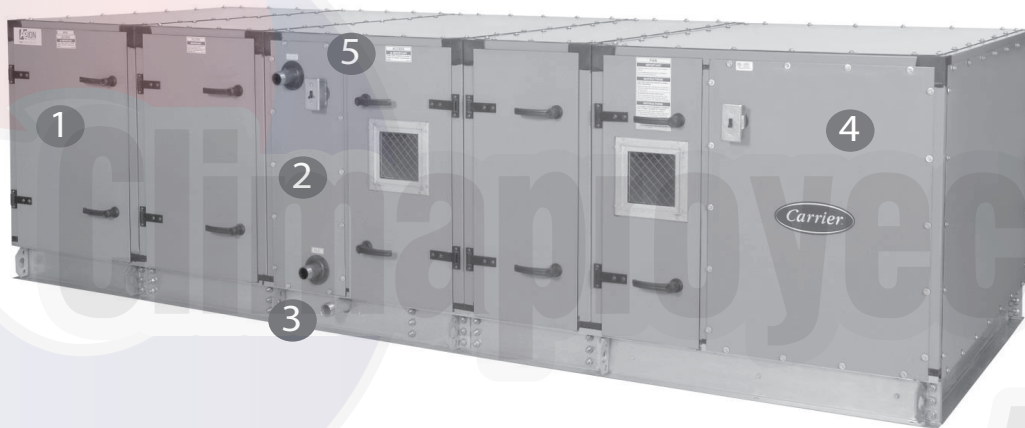

- 1 **Filtration flexibility:** Expanded filter and filter rack offerings designed to meet ASHRAE 52.1 standards.
- 2 **Expanded coil options:** Engineered solutions for coil face area variation ranging from small to large coil offering to meet cost and capacity requirements.
- 3 **Condensate control:** Minimum 2 in. thick, R-13 insulated drain pan as standard in all cooling coil selections. Optional drain pans available in other sections.
- 4 **Airflow measurement options:** Options such as piezometer rings and AMS dampers measure airflow for more precise unit control.
- 5 **Corrosion Prevention:** Electrofin<sup>\*\*</sup> e-coated option offered on coil selections.

\* Trademark of Scieasant.

† Registered trademark of the U.S. Green Building Council.

\*\* Registered Trademark of Luvata.

# AHRI certification



The Air-Conditioning, Heating, and Refrigeration Institute (AHRI) is a voluntary, nonprofit organization comprised of the manufacturers of air conditioning, refrigeration, and heating products. More than 90% of the air conditioning and refrigeration machinery and components manufactured in the United States is produced by members of AHRI.

Carrier 39M air handlers are rated in accordance with AHRI Standard 430, which is the industry standard for central station air-handling units. Certification by participating manufacturers of units within the scope of this program requires that the ratings and performance of any central station unit certified to AHRI be established in accordance with the AHRI Standard.

Electric heating coil ratings are not within the scope of the AHRI Central Station Air Handlers Certification program.

Coils installed in the Carrier 39M air handlers are rated and certified in accordance with AHRI Standard 410.

Plenum fans are rated in accordance with Air Movement and Control Association (AMCA) 210.



## Model number nomenclature

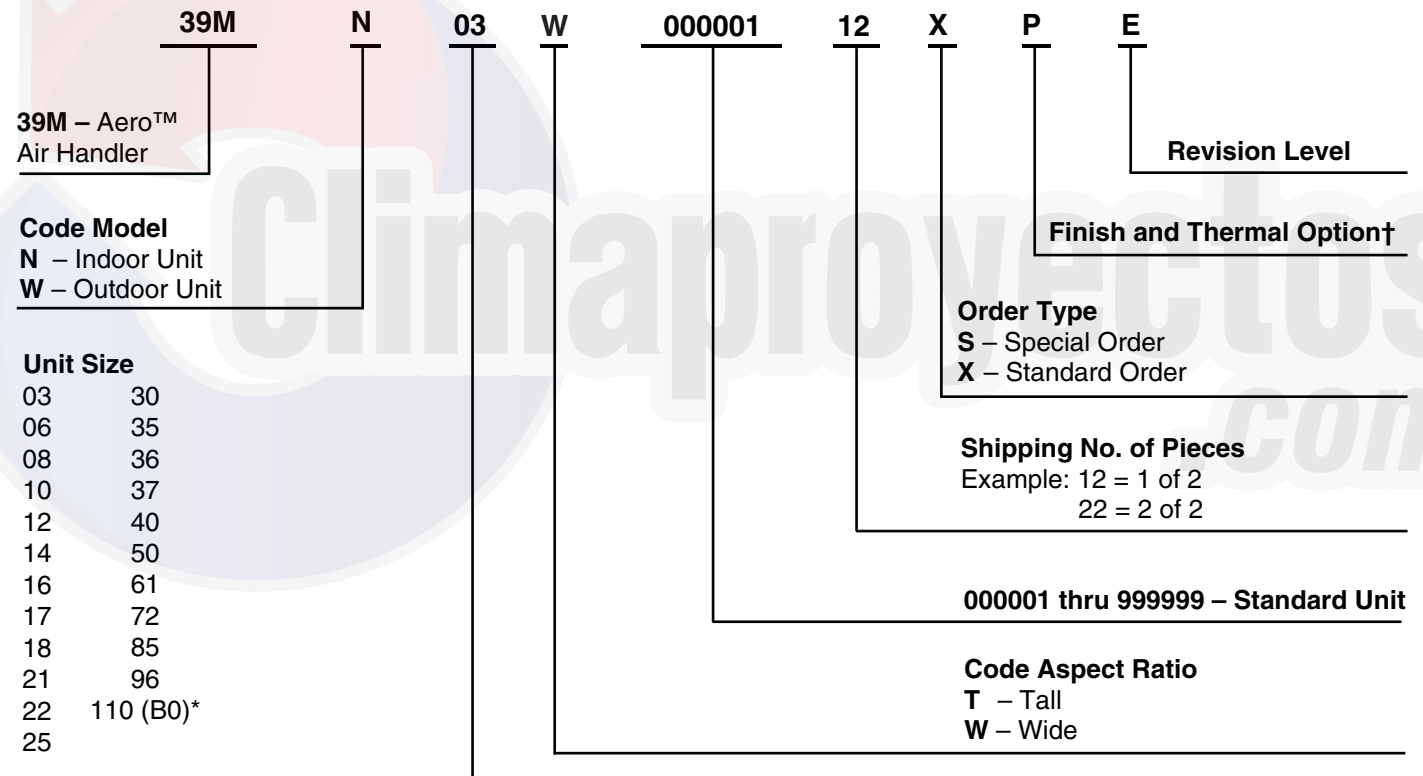

\*B0 should be used to select unit size 110.  
†See Finish and Thermal Option table.

### Quality Assurance

- ISO 9001:2008-certified processes
- MEA (Materials and Equipment Acceptance) number: 92-02-E



### FINISH AND THERMAL OPTION (POSITION 17)

CODE	EXTERNAL FINISH	INTERNAL FINISH	THERMAL BREAK
B	Pre-Paint	Agion	Level 1
C	Pre-Paint	Galvanized	Level 2
D	Pre-Paint	Galvanized	Level 1
F	Galvanized	Galvanized	Level 2
G	Galvanized	Galvanized	Level 1
H	Galvanized	Agion	Level 2
K	Galvanized	Agion	Level 1
L	Galvanized	Stainless Steel	
M	Galvanized	Stainless Steel	
P	Pre-Paint	Agion	Level 2
R	Pre-Paint	Stainless Steel	
S	Pre-Paint	Stainless Steel	
X	Special Order		

# Application data

## Central station air handler

The central station air handler is a heating, ventilating, or air-conditioning unit that is centrally located in, or on, a building or structure. The air handler distributes air to desired areas through a system of ducts.

### The 39M factory packaged unit

Individual components, such as fans, coils, and filters, are assembled at the factory.

Packaged equipment is less costly than field-fabricated equipment and does not require assembly.

The basic air-handling unit consists of a fan section and a coil section. Other components, such as filter sections, air-mixing boxes, access sections, and damper sections, may also be provided.

## Central station configurations

### Draw-thru units

#### Horizontal

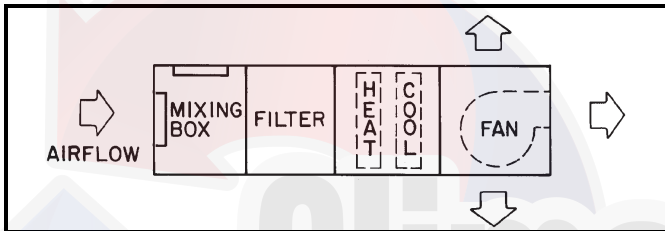

#### Vertical (indoor unit only)

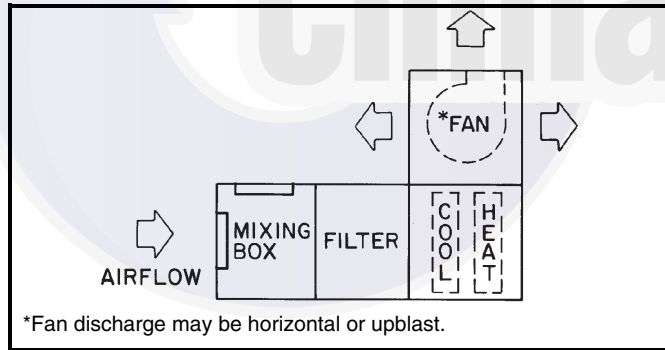

### Stacked return fan

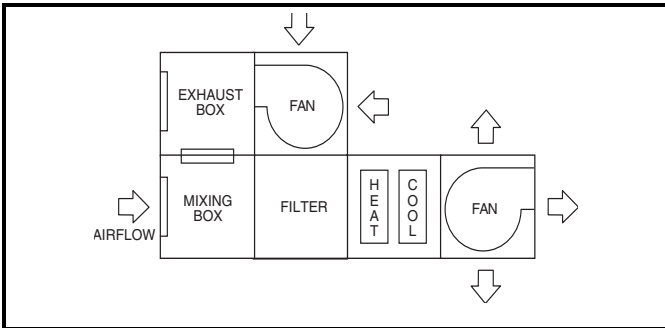

## Face and bypass units

### Horizontal

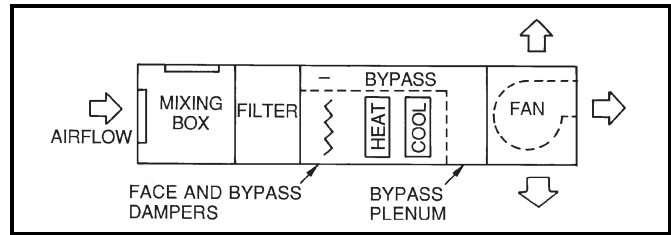

### Blow-thru units

Blow-thru arrangements are more suitable on systems with a significant amount of fan (and motor) heat. Fan heat can add 0.3° F to 0.5° F per in. of total static pressure to the airstream. Therefore, on such systems, it is more efficient to use a blow-thru arrangement and add the fan heat before the cooling coil. With a draw-thru unit, the airstream must be subcooled to anticipate the addition of fan heat downstream of the cooling coil. Thermal storage and cold air distribution systems benefit from blow-thru applications.

**Air mixing using a plenum fan** — A static air mixer is only effective between 900 and 1100 fpm. Using a blow-thru plenum fan as the air mixing device assures proper mixing at all airflows. This arrangement is best for VAV (variable air volume) systems and will eliminate the added expense of a static air mixer.

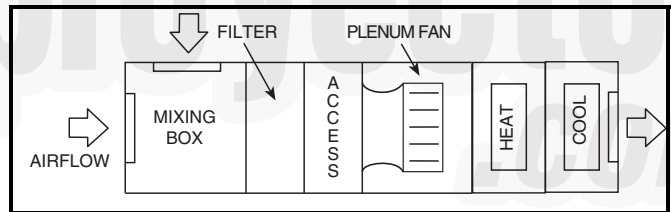

**Dual duct** — The unit delivers 2 outputs; one outlet produces hot air while the other produces cold air (indoor unit only).

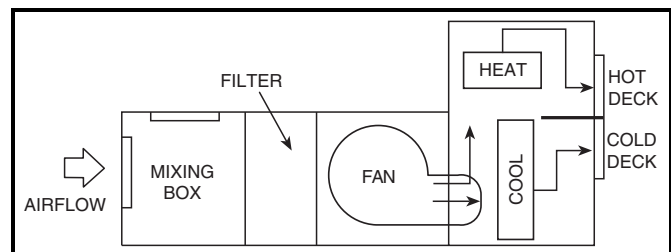

**Multizone** — Mixing dampers blend hot-deck and cold-deck temperatures to produce a desired temperature for individual zones. Several blending dampers per unit produce independent zones, each responding to its own thermostat (indoor unit only).

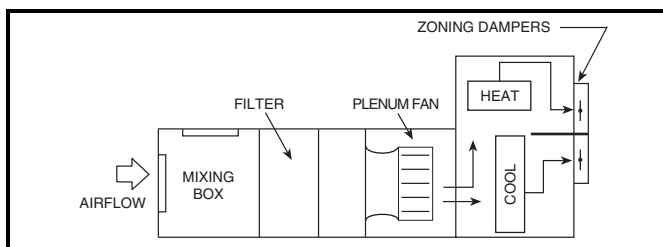

### High filtration units

High filtration units employ a filter section ahead of the cooling and heating coils. A second filter section, called a final filter, is placed at the end of the unit at the point where the air enters the ductwork.

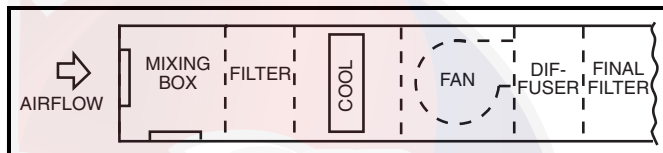

### Fans

The 39M central station air handlers use belt-driven centrifugal fans. A centrifugal fan is one in which the air flows radially through the impeller. Centrifugal fans are classified according to fan wheel and blade construction. The 39M fans can be selected as double width, double inlet (DWDI) with forward curved or airfoil blades. Plenum fans are selected as single width, single inlet (SWSI) with airfoil blades. Standard and small wheels are available on most sizes.

### Laws of fan performance

Fan laws are used to predict fan performance under changing operating conditions or by fan size. They are applicable to all types of fans.

The fan laws are stated below. The symbols used in the formulas represent the following variables:

- CFM* — Volume rate of flow through the fan.
- RPM* — Rotational speed of the impeller.
- P* — Pressure developed by the fan.
- Hp* — Horsepower input to the fan.
- D* — Fan wheel diameter. The fan size number can be used if it is proportional to the wheel diameter.
- W* — Air density, varying directly as the barometric pressure and inversely as the absolute temperature.

Application of these laws is limited to cases where fans are geometrically similar.

### FAN LAWS

VARIABLE	CONSTANT	LAW	FORMULA
<b>SPEED (RPM)</b>	Air Density Fan Size Distribution System	Airflow varies directly with the Speed.	$\frac{CFM_1}{CFM_2} = \frac{RPM_1}{RPM_2}$
		Pressure varies as the square of the Speed.	$\frac{P_1}{P_2} = \left(\frac{RPM_1}{RPM_2}\right)^2$
		Horsepower varies as the cube of the Speed.	$\frac{HP_1}{HP_2} = \left(\frac{RPM_1}{RPM_2}\right)^3$
<b>FAN SIZE (D)</b>	Air Density Tip Speed	Capacity and Horsepower vary as the square of the Fan Size.	$\frac{CFM_1}{CFM_2} = \frac{HP_1}{HP_2} = \left(\frac{D_1}{D_2}\right)^2$
		Speed varies inversely as the Fan Size.	$\frac{RPM_1}{RPM_2} = \frac{D_2}{D_1}$
		Pressure remains constant.	$P_1 = P_2$
	Air Density Wheel Speed	Capacity varies as the cube of the Size.	$\frac{CFM_1}{CFM_2} = \left(\frac{D_1}{D_2}\right)^3$
		Pressure varies as the square of the Size.	$\frac{P_1}{P_2} = \left(\frac{D_1}{D_2}\right)^2$
		Horsepower varies as the fifth power of the Size.	$\frac{HP_1}{HP_2} = \left(\frac{D_1}{D_2}\right)^5$
<b>AIR DENSITY (W)</b>	Pressure Fan Size Distribution System	Speed, Capacity, and Horsepower vary inversely as the square root of Density.	$\frac{RPM_1}{RPM_2} = \frac{CFM_1}{CFM_2} = \frac{HP_1}{HP_2} = \left(\frac{W_2}{W_1}\right)^{1/2}$
	Airflow Fan Size Distribution System	Pressure and Horsepower vary with Density.	$\frac{P_1}{P_2} = \frac{HP_1}{HP_2} = \frac{W_1}{W_2}$
		Speed remains constant.	$RPM_1 = RPM_2$

# Application data (cont)



## Fan selection criteria

**System requirements** — The major factors that influence fan selection are airflow, external static pressure, fan speed, brake horsepower, and sound level. Additional system considerations include the fan control method, overloading, and non-standard air density. Fan selection for air-conditioning service usually involves choosing the smallest fan that provides an acceptable level of performance, efficiency and quality.

**Pressure considerations** — The static pressure is the resistance of the combined system apart from the fan. Contributors to static pressure include other components in the air handler, ductwork, and terminals. The static pressure is dependent on the airflow through the system, which is determined by the air conditioning requirements. As shown in the second fan law in the table on the preceding page, the static pressure varies as the square of the airflow (cfm). This ratio between pressure and airflow determines the system curve for any air-handling system.

The static pressure used to select a fan should be the pressure calculated for the system at design airflow. If the static pressure is overestimated, the increase in horsepower and air volume depends upon the steepness of the fan curves in the selection area.

With forward-curved (FC) fans, if the actual system static pressure is less than the design static pressure, the fan has a tendency to deliver more air and draw correspondingly higher bhp (kW of energy). This higher current draw may overload the motor and trip circuit breakers. This is a common occurrence when FC centrifugal fans are operated before all the ductwork has been installed, or during the pull-down load on a VAV system.

With airfoil (AF) fans (non-overloading), if the actual static pressure is less than the design static pressure, the fan delivers more air with little or no increase in bhp in most applications. In this case, adding a safety factor to the calculated static pressure can increase fan horsepower (and costs) unnecessarily.

**Stability** — Fan operation is stable if it remains unchanged after a slight temporary disturbance, or if the fan operation point shifts to another location on the fan curve after a slight permanent disturbance. Fan operation is unstable if it fluctuates repeatedly or erratically. There are 2 main types of unstable fan operation:

*System surge* is a cycling increase and decrease in system static pressure.

*Fan stall* is the most common type of instability, and it occurs with any type of centrifugal fan when the fan is starved for air.

Normally, the rotation of the fan wheel forces the air through the blade passageway from the low pressure to the high pressure side of the fan. If the airflow is restricted too much, however, there is not enough air to fill the space between the blades and the air distribution between the blades becomes uneven and erratic. Air can flow backwards through the wheel, substantially increasing the noise level. If the fan runs in this condition for a long time, wheel failure will likely occur.

For a given speed, the operating point where a fan stalls is a function of the wheel geometry and wheel speed. In general, the stall point is within 15 to 25% of the airflow obtained at free delivery.

**Stability and VAV applications** — Special considerations must be made for VAV systems. While the initial fan selection may be acceptable, its operating point could shift to a point of stall at minimum airflow and pressure conditions. The typical minimum airflow is half of the design cooling airflow, which is also often equal to the heating airflow. To determine and plot the minimum airflow versus static pressure, use the following equation. This equation solves for the static pressure at a specific airflow based on a minimum static pressure set point:

$$\left( \left( \frac{CFM_1}{CFM_{DESIGN}} \right)^2 \times (SP_{DESIGN} - SP_{MIN}) \right) + SP_{MIN} = SP_1$$

$$\left( \left( \frac{7,500}{15,000} \right)^2 \times (4 - 2) \right) + 2 = 2.50 \text{ in. wg}$$

**CFM** — Airflow in Cubic Feet Per Minute  
**SP** — Static Pressure

The table below illustrates a system with an airfoil fan wheel at a cooling design of 15,000 cfm and a system static pressure of 4 in. wg. The minimum airflow is 7,500 cfm with a minimum system static pressure set point of 2 in. wg. **The minimum static set point is based on zero airflow and does not coincide with the minimum design airflow.**

Example:

% CFM	CFM	SYSTEM AND FAN STATIC PRESSURE in. wg
100	15,000	4.00
90	13,500	3.62
80	12,000	3.28
70	10,500	2.98
60	9,000	2.72
50	7,500	2.50

As shown on the highlighted VAV curve, the minimum airflow and static pressure (MP) are both well within the fan's acceptable operating conditions.

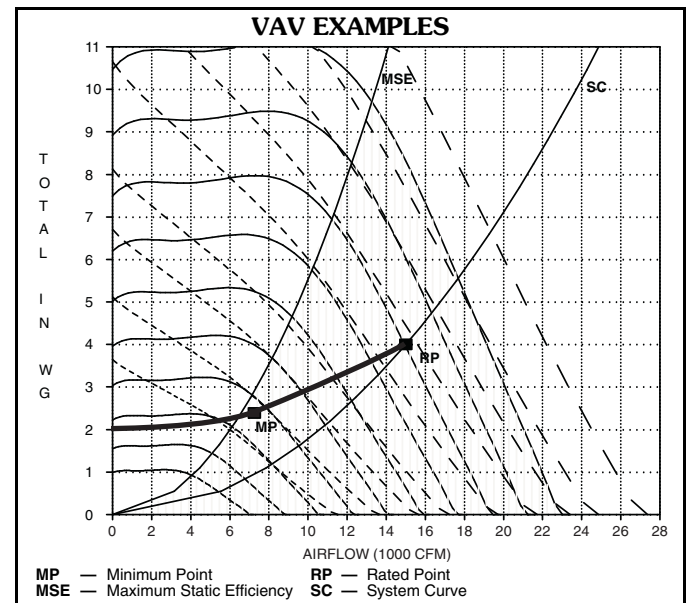



**Sound considerations** — The fan is one of the main sound sources in an air-conditioning system. Other sources of sound include the duct system and terminals, because they generate turbulence in the air flowing through them. Simply estimating fan sound does not give an accurate picture of total system sound, but fan sound is a major component of system sound, and should be minimized.

To minimize its sound generation, a fan must be correctly sized and selected to operate at or near peak efficiency. Oversized fans can generate much higher sound power levels than necessary, especially in VAV systems operating at low airflows. Undersized fans can also result in higher sound power levels because of increased fan speeds and the higher tip velocity of the air leaving the fan blades.

For VAV systems, the part load point at which the fan operates most of the time should be used to select a fan for lowest sound output.

Variable frequency drives (VFDs) are used to modulate fan volume. A VFD reduces the sound power level as the fan speed is reduced. At 50% load, the sound level is reduced approximately 15 dB compared to the sound level at 100% load. When using variable frequency drives, it is important that the static deflection of the vibration isolators is adequate. At very low fan speeds, the fan frequency may approach the natural frequency of the spring isolation. If this happens, the vibration levels can be amplified and resonant vibration conditions can occur.

When sound level is a major consideration, a blow-thru fan should be considered because of the reduced discharge sound level. This sound reduction is due to the sound absorption of the coil section downstream from the fan. Transition fittings and elbows can be reduced in size or eliminated, thereby eliminating a sound source.

To obtain projected sound data for a selected 39M unit, use the electronic catalog **AHUBuilder®** program.

**Dirty filtration considerations** — Consider selecting an air handler with dirty filters so that, in theory, the unit will have enough horsepower to deliver the same amount of air when the filters are dirty. On a constant volume unit, that would only work if the unit contained an airflow measuring station and could adjust the flow accordingly via a VFD. Otherwise, the point of operation moves along the rpm line as the static pressure in the system changes.

What happens when you order the fan with sheaves selected for dirty filters? Three things:

1. The air balancer forces the selection of a smaller sheave because the airflow is too high. When the filters load up, airflow is reduced.
2. If an air balance is not performed, the cooling coil may exhibit moisture carryover due to the considerable increase in airflow.
3. The fan motor trips out on overload with the forward curve fan because of the increase in bhp.

Example:

Forward-Curved Fan, 15,000 cfm, 1010 rpm, 17.8 hp, selected with 100% dirty 60 to 65% cartridge filters and pre-filters. Dirty filters result in a total static pressure (TSP) of 4 inches.

Clean filters result in a TSP of 2.55 inches.

In the chart below, follow the 1010 rpm line down to 2.55 inches.

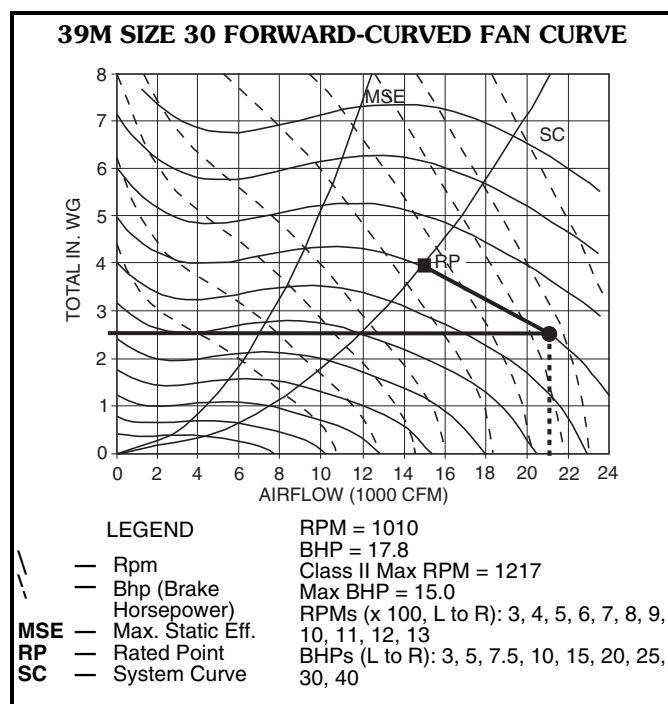

Airflow with a clean filter will be 21,000 cfm. Also note that the horsepower goes from 17.8 bhp to about 28 bhp because the FC fan is an overloading type fan.

So, if dirty filters need to be taken into consideration, do one of the following:

1. Make the final fan selection with the **clean** filter rpm but use the motor horsepower requirement for **dirty** filters.
2. Make the final fan selection with the **dirty** filter rpm and use the motor horsepower requirement for **dirty** filters – **only if** the engineer plans on using a VFD and airflow measurement station or if it is a VAV system.
3. Use an airfoil fan when the difference between dirty and clean filter pressure drop is greater than 1 inch. That way, the difference between clean and dirty airflow is minimized.

Example:

Airfoil Fan, 15,000 cfm, 2210 rpm, 18.8 hp, selected with 100% dirty 60 to 65% cartridge filters and pre-filters. Dirty filters result in a total static pressure (TSP) of 4 inches.

Clean filters result in a TSP of 2.55 inches.

# Application data (cont)



In the chart below, follow the 2210 rpm line down to 2.55 inches.

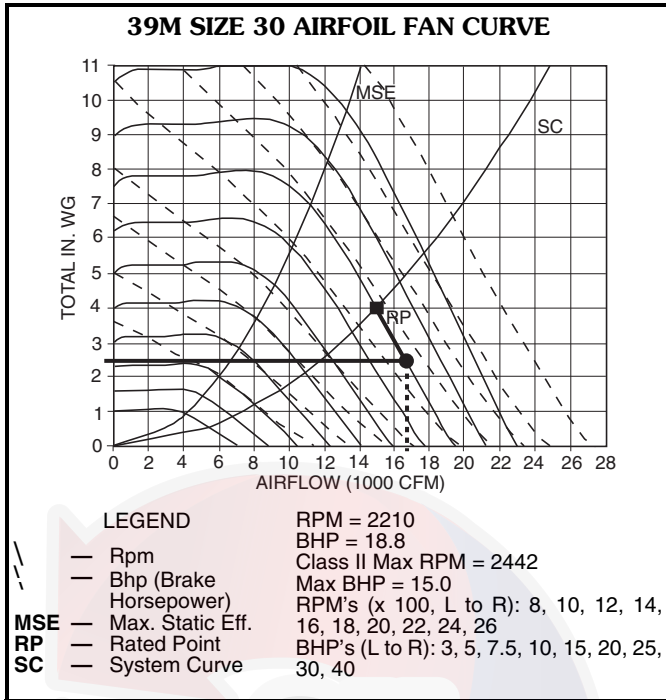

Airflow with a clean filter will be 16,700 cfm. Since airfoil fans are non-overloading (bhp lines run parallel with rpm lines) the bhp does not change (actually, bhp decreases).

**Fan, motor, and drive heat considerations** — The work output of a fan and its motor and drive contribute directly to the airflow and pressure exiting the air handler. Not all of the fan energy output generates airflow, however. Fan motors are not 100% efficient, and their efficiency loss translates directly into heat that must be factored in when calculating the temperature rise across a fan section. Fans also add a certain amount of heat to the airstream due to the effects of compression and bearing friction. Finally, belt drives do not transmit all of the energy generated by the motor. Some of the energy is lost as heat due to belt tension and the type and number of belts. Belt drive bhp losses range from 2 to 6 percent; a 3% loss is typical.

Because the 39M Series air handlers all have fans, motors, and drives located within the airstream, heat losses from these components affect the power requirements, cooling load, and heating load.

Power losses in the motor and drive should be allowed for when determining the motor output (bhp), so that the motor can be correctly sized and the additional heat output can be subtracted from cooling capacity or added to heating capacity. A typical example follows:

Given Fan Operating Point:

- 13,224 cfm
- 9.6 Fan bhp
- 3.0% Estimated drive loss

Calculate the required fan motor output ( $H_p$ ) due to drive loss.

$$H_p = (\text{Fan bhp}) \times (\text{Drive Loss})$$

$$H_p = 9.6 \times 1.03$$

$$H_p = 9.89 \text{ hp (select 10 Hp motor)}$$

Calculate the total fan motor heat output ( $Q$ ) according to motor efficiency:

$$Q = (\text{Motor Output}) \div (\text{Motor Efficiency [Typical]})$$

$$Q = 9.89 \div 0.86$$

$$Q = 11.5 \text{ hp}$$

Convert horsepower to Btu per hour.

$$11.5 \text{ hp} \times 2545 = 29,268 \text{ Btuh}$$

Calculate the increase in leaving-air temperature ( $\Delta T$ ) due to fan and motor heat and drive losses:

$$Q = 1.1 \times \text{cfm} \times \Delta T$$

$$29,268 \text{ Btuh} = 1.1 \times 13,224 \times \Delta T$$

$$29,268 \text{ Btuh} = 14,546.4 \times \Delta T$$

$$\Delta T = 2.01 \text{ F (use to estimate coil requirements)}$$

## Fan application

Certain fans are more efficient in low static pressure systems, while others operate best in higher pressure systems. Some fan types are designed to handle very large air volumes while others are more efficient at lower volumes. See the Fan Type and Application table on page 12.

**Forward-curved (FC) fans** are typically used for low to medium pressure applications (0 to 5 in. wg total static pressure [TSP]).

The FC fans are reasonably stable over a wide airflow (cfm) range at constant speed. Because of the relatively flat curve, FC fans tolerate modulation in airflow without large increases in static pressure. Most important, FC fans have the lowest first cost.

**Airfoil (AF) fans** are most efficient at higher static pressures (4.0 to 8.0 in. wg total static pressure).

Because of the shape of the AF fan performance curve, bhp decreases as air volume decreases only when a VAV volume control device, such as a variable frequency drive (VFD), is used.

Airfoil fans are more expensive than FC fans and, in addition, there is a price premium for the volume control device, if required.

**Plenum fans** (sometimes called “plug” fans) are typically used in medium to high static pressure applications where ductwork requires discharge location flexibility. They can reduce the need for ductwork turns or diffusers, especially when equipment room space is limited.

Plenum fans are less efficient than double-width, double-inlet airfoil fans. General construction also differs from that of FC or AF fans. The fan does not have a scroll to enclose the fan wheel and direct airflow. Instead, the entire interior of the plenum fan section is pressurized by the fan.

Plenum fans have single-width, single-inlet (SWSI) construction. The fan shaft is parallel with the airflow, and the motor and bearings are located inside the plenum in the pressurized airstream. An optional inlet screen and wheel cage can be installed to help protect personnel during maintenance.

Plenum fans are generally used where there are space limitations, a need for discharge flexibility, a need for reduced discharge sound, or where duct configurations might change in the future. For example, in an application where there is not enough room in the building for a large main duct, several smaller duct runs may approach the mechanical equipment room from all sides. In such an application, several connections can be made to one or more sides of the plenum fan section. Installing contractors can cut outlets in the plenum box at the time of installation to suit the conditions at the jobsite.

Because the casing of a plenum fan section acts as a sound attenuator, plenum fans are also sometimes used when discharge sound levels need to be reduced.

Duct takeoffs from plenum fans can have relatively high pressure losses and can also create turbulence that causes a larger pressure drop across coil and filter sections. When selecting a plenum fan, the pressure drop for the duct takeoffs must be added to the external static pressure for the rest of the system.

**To calculate the pressure losses from plenum fan duct takeoffs, use the following formula and refer to the figure at right.**

$$P_l = P_p - P_d = (C_v) (V_p)$$

Where  $P_l$  is the pressure loss,  $P_p$  is the plenum pressure,  $P_d$  is the duct pressure,  $C_v$  is the pressure loss coefficient, and  $V_p$  is the velocity pressure in the duct. Note that for radial duct takeoffs,  $C_v$  is 1.5 in. wg, while for axial duct takeoffs,  $C_v$  is 2.0 in. wg. To calculate velocity pressure ( $V_p$ ) in the duct, use the following formula, where  $V$  is the air velocity in the duct:

$$V_p = [(V) \div (4005)]^2$$

Also note that with more than one duct takeoff and different duct velocities, the highest duct velocity and highest  $C_v$  value should be used in the formulas.

### Duct design considerations (system effect prevention)

The discharge ductwork immediately downstream from the fan is critical for successful applications. Poorly designed ductwork can degrade fan performance and contribute to excessive pressure drop and noise.

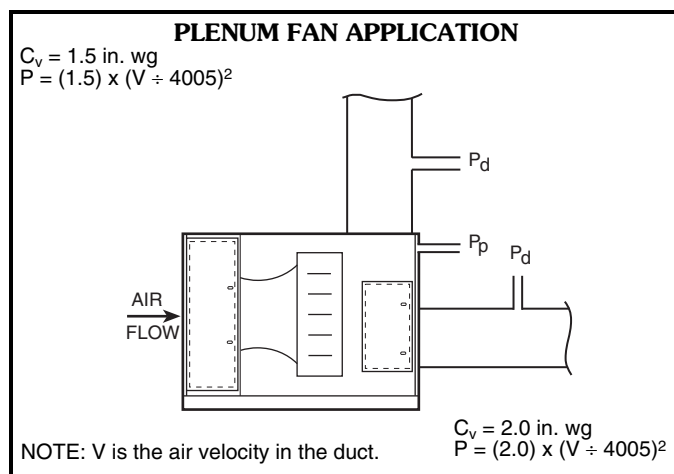

The 39M Series airfoil and forward-curved fans are tested as part of a system with straight discharge ductwork, and the fan ratings are based on this duct design. When designing ductwork in the field, it is important to use a straight discharge duct of the correct dimensions to obtain maximum fan performance. Straight ductwork helps the airflow to develop a uniform velocity profile as it exits the fan and allows the velocity pressure to recover into static pressure. See the figure below.



For 100% recovery of velocity pressure into static pressure, the straight portion of the discharge duct must be at least at least 2 1/2 times the discharge diameter in length for velocities of 2500 fpm or less. For each additional 1000 fpm, add one duct diameter to the length of the straight portion of the ductwork.

As an example of how to size the straight portion of duct, assume the fan has a 34 x 34 in. discharge outlet (8.03 sq ft). The equivalent diameter is 39 in., so the straight duct length required would be 8 ft long.

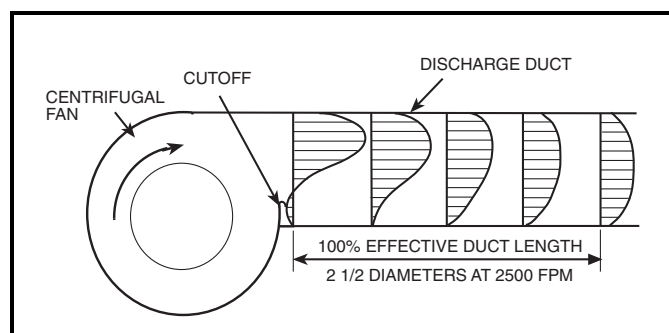
Plenum fans do not require straight ductwork of a particular minimum length, because velocity pressure is converted to static pressure inside the plenum fan section. Outlet ducts, however, should not be installed directly in line with the air discharge from the fan wheel.

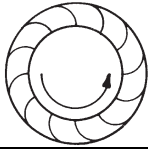

## FAN TYPE AND APPLICATION

TYPE	CHARACTERISTICS	APPLICATION
<b>Forward-Curved (FC)</b> <b>Side View</b> 	<ul style="list-style-type: none"> <li>• Double-width, double-inlet (DWDI) construction.</li> <li>• Best at low or medium pressure (approximately 0 to 5 in. wg).</li> <li>• Horsepower increases continuously with increase in air quantity (overloads) as static pressure decreases.</li> <li>• Less expensive than AF fans.</li> <li>• Runs at relatively low speed, typically 400 to 1200 rpm.</li> <li>• Blades curve toward direction of rotation.</li> </ul>	For low to medium pressure air-handling applications.
<b>Airfoil (AF)</b> <b>Side View</b> 	<ul style="list-style-type: none"> <li>• Double-width, double-inlet (DWDI) construction.</li> <li>• Best in high capacity and high-pressure applications (4 to 8 in. wg).</li> <li>• Horsepower peaks at high capacities.</li> <li>• Most expensive of centrifugal fans.</li> <li>• Operates at high speeds, typically 1200 to 2800 rpm. About double the speed of FC fan for similar air quantity.</li> <li>• Blades have aerodynamic shape similar to airplane wing and are curved away from direction of rotation.</li> </ul>	For medium to high air capacity and pressure applications.
<b>Plenum (PAF)</b> <b>End View</b> 	<ul style="list-style-type: none"> <li>• Single-width, single-inlet (SWSI) construction.</li> <li>• Characteristics similar to DWDI airfoil fan.</li> <li>• Blades have aerodynamic shape similar to airplane wing and are curved away from direction of rotation. Fewer blades and wider blade spacing than AF fans.</li> </ul>	Best in applications with limited space or multiple ducts.

## Fan control on variable air volume systems

### Introduction

Since VAV systems inherently reduce airflow to meet demand, they are a major source of energy savings. This occurs because fan brake horsepower (bhp) varies with the amount of air delivered.

The degree to which bhp savings are realized, however, is also affected by the type of fan volume control selected and the effectiveness of its application. Effective fan control ensures proper duct pressure for the required control stability of the air terminals and provides quiet terminal unit operation when “riding the fan curve.”

Consider the following when selecting a fan volume control method:

1. System parameters
  - a. Airflow (cfm)
  - b. Static pressure
  - c. Percent volume reduction (turndown)
2. Fan type and selection point
  - a. Design point efficiency
  - b. Part load efficiency (especially the point where the fan will be operating most of the time)
  - c. Part load stability
3. Ease of control installation and use
4. Motor selection
  - a. Higher bhp inputs due to efficiency of VAV control method
  - b. Compatibility with VAV control
5. Sound levels
  - a. Fan-generated sound
  - b. Terminal sound
  - c. Control-generated sound
  - d. System sound (ducts, fittings)
6. Initial cost and operating cost
7. Reliability and ease of maintenance



# Application data (cont)



As the load decreases in a VAV system and the terminal units throttle, duct static pressure increases. A static pressure sensor in the duct system detects the pressure increase and initiates a fan speed change through the VFD. Fan speed is reduced until the duct sensor detects a satisfactory duct pressure.

The Variable Frequency Fan Speed Control chart illustrates the results of fan speed reduction as operation shifts from Point A to Point B. If duct pressure begins to fall due to terminal units opening, the duct sensor signals the VFD to increase fan speed.

This method of air volume control permits fan speed reduction down to as low as 10% of the design speed. With FC fans riding the fan curve at the lower rpm, airflow may be as low as 10% of peak design, as long as motor rpm is not less than 1/6 of motor synchronous speed.

The method may be applied to any size VAV system with any type of fan. It is particularly cost effective on systems with high turndown requirements where the full speed reduction capability can be used.

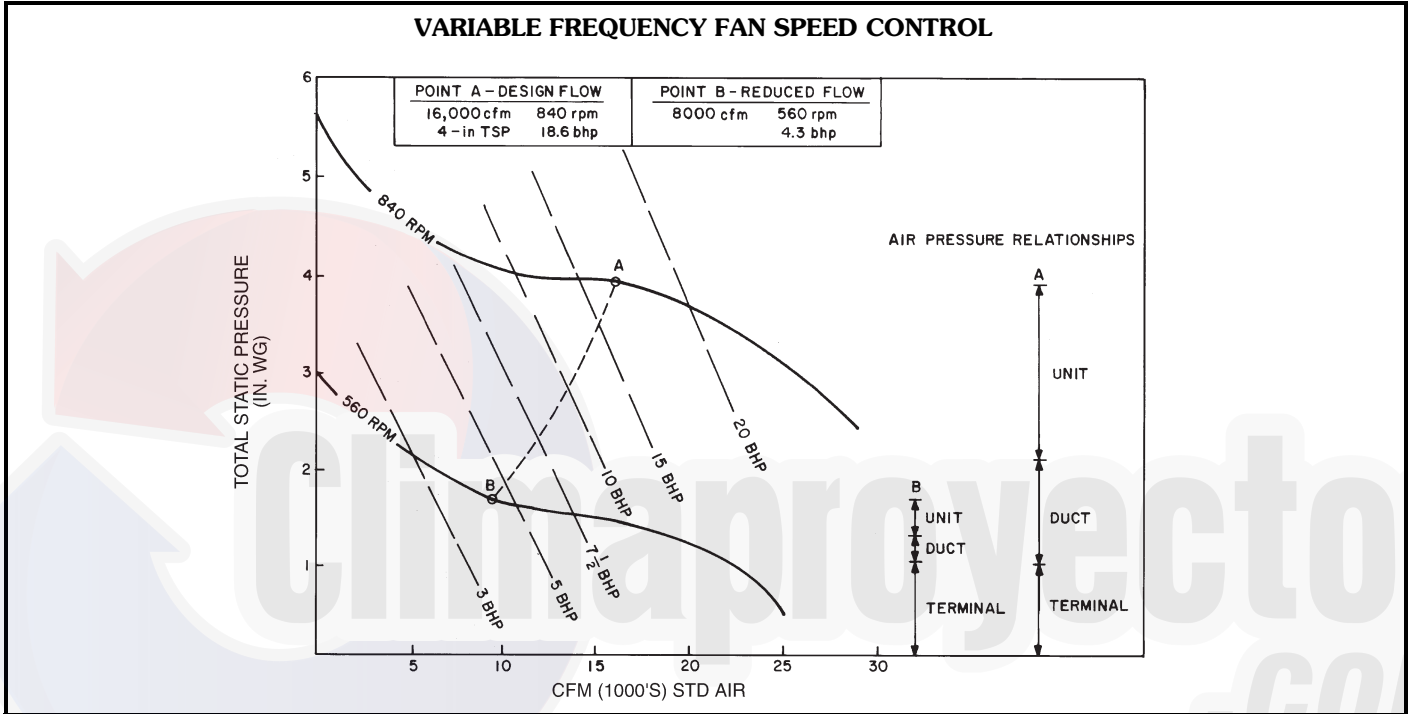

## FAN SUMMARY COMPARISON

TYPE OF CONTROL	FIRST-COST RANK	SOUND GENERATION RANK*	ENERGY-SAVINGS RANK	APPLICATION RANGE — NORMAL FOR AIR COND.	COMMENTS
FC Fan Terminal Throttling (Riding Fan Curve)	1 (Lowest Cost)	4	4	TSP 0 to 4.5 in. wg Cfm 3,000 to 35,000	For moderate turndown systems with a flat fan curve and low to medium static pressure and cfm range.
FC Fan with 2-Speed Motor	2	3	3	TSP 0 to 4.5 in. wg Cfm 3,000 to 35,000	For systems with predictable 2-load situations in low to medium static pressure range. Controls are more complicated. Starters are more costly.
FC Fan With Variable Frequency Drive	3	1 (Quietest)	1 (Best)	TSP 0 to 4.5 in. wg Cfm 3,000 to 35,000	For high turndown, low to medium static pressure systems. Best energy savings. Fast payback. Fan generates least sound.
AF and Plenum Fan With Variable Frequency Drive	4	1 (Quietest)	1 (Best)	TSP 4.5 to 8.0 in. wg Cfm 5,000 to 63,000	For high turndown, medium to high static pressure systems. Best energy savings. Fan generates least sound.

### LEGEND

- AF — Airfoil
- FC — Forward Curved
- TSP — Total Static Pressure

\*Including part load.

NOTE: Rank is based on a relative scale of 1 to 4. Some methods have comparable rating.

## Unit control arrangements with Carrier Direct Digital Controls

### Supply fan control

In a VAV system, supply fan control is used to match the supply fan delivery to the airflow required by the load. This is done by maintaining a constant static pressure in the supply duct at a point approximately  $\frac{2}{3}$  of the distance from the supply fan discharge.

The DDC processor uses a control loop to provide the capability. This processor measures the static pressure at the pick-up probe, compares it to the desired set point, and modulates the fan volume control device. See the Supply Fan Control figure. The volume control device can be a factory-installed or field-installed variable frequency drive (VFD).

The VFD provides the ability to maintain control over a much larger airflow range (it has a higher turn-down ratio). The following guideline should be used to ensure proper control:

- Variable frequency drives should not be operated at below  $\frac{1}{6}$  motor synchronous speed.

For supply fan applications, the DDC processor option maintains the duct static pressure at a desired set point between 0.2 and 4.5 in. wg to within  $\pm 0.1$  in. wg throughout the fan control range. In applications where more than 100 ft of pneumatic tubing is required, the transducer must be removed from the control box and remotely mounted near the static pressure pickup.

### Indoor air quality (IAQ) applications

The CO<sub>2</sub> demand-controlled ventilation (DCV) override increases the minimum ventilation level in order to maintain the CO<sub>2</sub> level at or below the maximum level per person. By ventilating only to the actual rate required, rather than the maximum design occupancy rate, energy savings are achieved. When combined with Product Integrated Controls, this feature automatically adapts and changes ventilation quantity without operator set point adjustments. The CO<sub>2</sub> DCV override feature has user-selectable values for minimum mixed-air temperature override, maximum damper ventilation override position, and supply air tempering (when hot water/steam heat is used).

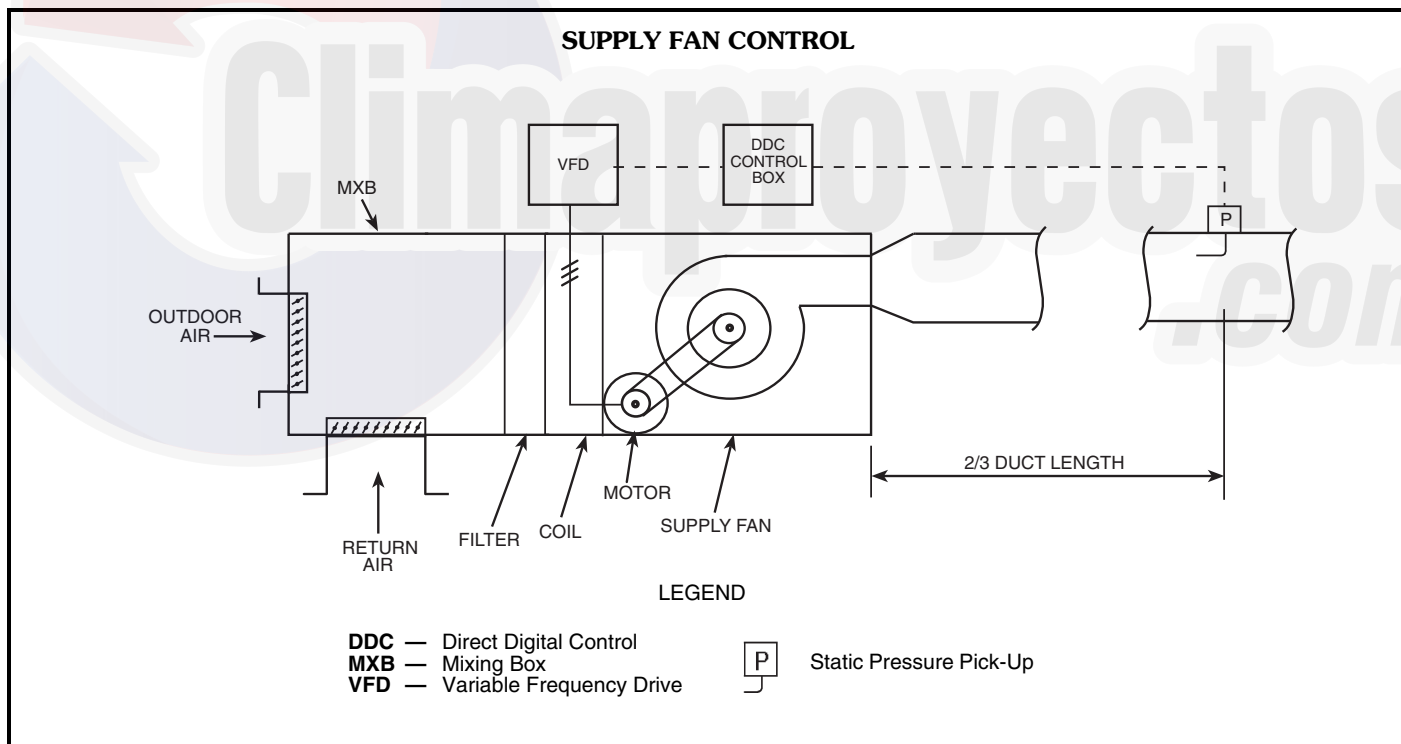

# Application data (cont)



## Coils

### Coil definitions

A coil, as the term is used with air-handling equipment, is a heat exchange device. A heating or cooling medium passes through the coil, where it either rejects heat to, or absorbs heat from, the airstream passing over the coil, depending upon the relative temperatures of the medium and airstream.

**Tube** — The tube is a small-diameter pipe through which the heating or cooling medium passes as it rejects or absorbs heat. Coil tubes are generally constructed of copper but may be made of other metals.

**Fin** — The coil fin is a thin metal plate attached to the tube to improve the heat transfer efficiency from medium to airstream. Typically, it is made of either aluminum or copper.

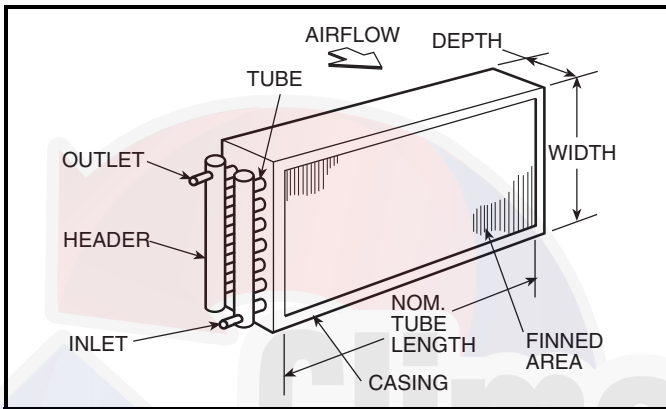

**Header** — The header is a large diameter pipe to which several tubes are connected. It distributes the heating or cooling medium to the tubes. Headers are typically of non-ferrous metal or steel.

**Casing** — The supporting metal structure for tubes and header is called a casing. It is usually made of galvanized steel but can be made of other materials (stainless steel).

**Inlet and outlet** — These are pipe stubs on the header where the heating or cooling medium enters and leaves the coil.

In water coils, the supply inlet is the pipe stub located on the side where the air leaves the coil. The outlet is the stub on the entering air side of the coil. Such an arrangement is known as counterflow.

In steam coils, the inlet is always the higher stub so that condensate will drain out of the lower stub.

**Finned area or face area** — The working area of the coil is defined as the width x length of the finned area through which air passes. This finned or face area does not include the casing.

**Face velocity** — This is the air velocity in fpm across the finned or face area of a coil. Face velocity is determined by dividing the air volume in cfm by the coil face area in square feet.

$$\text{Face Velocity (Fpm)} = \frac{\text{Air Volume (Cfm)}}{\text{Coil Face Area (Sq Ft)}}$$

The first step in selecting an air handler size is to determine the maximum allowable face velocity.

This maximum is determined by the specifier and is based primarily on the following criteria:

1. Avoidance of moisture carryover into the ductwork (applies to cooling coils only).
2. Air pressure drop across the coil.
3. Heat transfer efficiency.

The maximum safe air velocity without moisture carryover into the ductwork depends on the type and spacing of the finned surface, the amount of moisture on the coil, and the geometry between coil and fan inlet or ductwork. Since coil moisture conditions vary, and coil versus duct geometry varies (for example, between draw-thru, blow-thru, vertical, or horizontal units), the specified maximum face velocity should allow for these variations.

Fan horsepower is also affected by face velocity, since the air resistance across the coil varies roughly as the square of the face velocity.

For the above reasons, the maximum specified face velocity is normally a conservative figure (on the low side). Suggested design face velocities are as follows:

COIL TYPE	FACE VELOCITY RANGE
Cooling	400 to 550 fpm
Heating	400 to 800 fpm

In variable air volume (VAV) applications, the system generally operates below peak air volume for extended periods. In such cases, the design face velocity is commonly selected at the higher end of the suggested range.

**Tube face** — This is the number of tubes in any one coil row.

Below is a diagram of a 4-row coil with a 4-tube face. Note that tubes are staggered in adjacent rows.

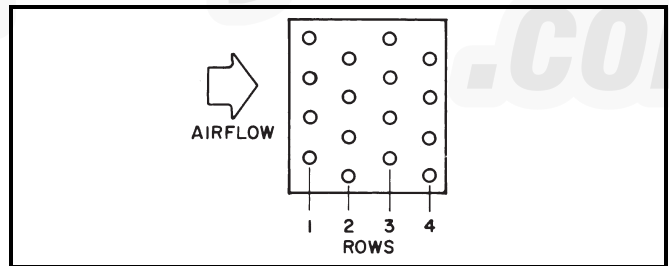

Cooling coils are typically available in 4, 6, 8, and 10-row configurations. Tubes should have an outside diameter (OD) of 1/2 in. to maximize heat transfer at minimum water flows. Coils should be sized for the most efficient use of water. Water temperature differences of 12 to 16° F are typical and represent optimum selection points.

**Pass** — That part of the circuit that passes through the airstream once.

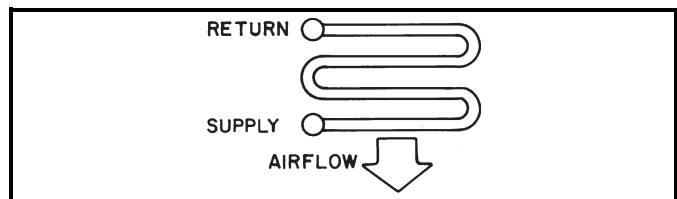

Note that this is a 4-pass circuit.



**Direct expansion (DX) coils** — Direct expansion coils can have two intertwined refrigerant circuits. In addition, quarter, half, full and double circuiting configurations are offered to allow optimum system performance and oil return at full and part-load operation.

Circuiting selection should result in a circuit loading of 0.8 to 2.0 tons per circuit at design load. Circuit loading must be evaluated at minimum load to ensure that it does not drop below 0.6 tons per circuit. Solenoid valves may be used, if necessary, to shut off the refrigerant supply to individual expansion valves to maintain adequate coil circuit loading.

Compressor minimum unloading and TXV quantity is necessary to determine minimum tonnage per circuit.

Minimum Unloading Equation:

$$\frac{(Tons/Circuit) \times (Minimum Unloading) \times (Total \# \text{ of TXVs})}{\# \text{ of TXVs Active}}$$

Example:

Condensing Unit: 38AUZ012  
 Minimum Unloading: 33%  
 Coil: 6 row, 11 FPI, Half Circuit  
 Coil Tons/Circuit: 1.68  
 Total TXVs: 2

In the first example we will determine the tons/circuit when both TXVs are active and the compressor is unloaded to its minimum of 33%.

$$= \frac{(1.68 \text{ Tons/Circuit}) \times (33\% \text{ Minimum Unloading}) \times (2 \text{ TXVs})}{2 \text{ TXVs Active}}$$

$$= \frac{(1.68) \times (.33) \times (2)}{2}$$

= .55 tons/circuit at minimum unloading: UNACCEPTABLE

If we install a liquid line solenoid valve before one of the TXVs and close it so that only one TXV is active when the compressor is unloaded to its minimum of 33 %, we see the following:

$$= \frac{(1.68 \text{ Tons/Circuit}) \times (33\% \text{ Minimum Unloading}) \times (2 \text{ TXVs})}{1 \text{ TXV Active}}$$

$$= \frac{(1.68) \times (.33) \times (2)}{1}$$

= 1.10 tons/circuit at minimum unloading: ACCEPTABLE

Thermostatic expansion valve (TXV) kits are available through **AHUBuilder**® software. If TXVs are purchased from an alternate vendor, be sure to specify a 5% minimum bleed port.

## Ethylene glycol

The effects of ethylene glycol usage on coil capacity and pressure drop can be determined from the **AHUBuilder**® program. For a quick estimate of these effects, use the chart below.

The chart is based on 6-row/14-fin coil performance with the only variable being ethylene glycol concentration by weight.

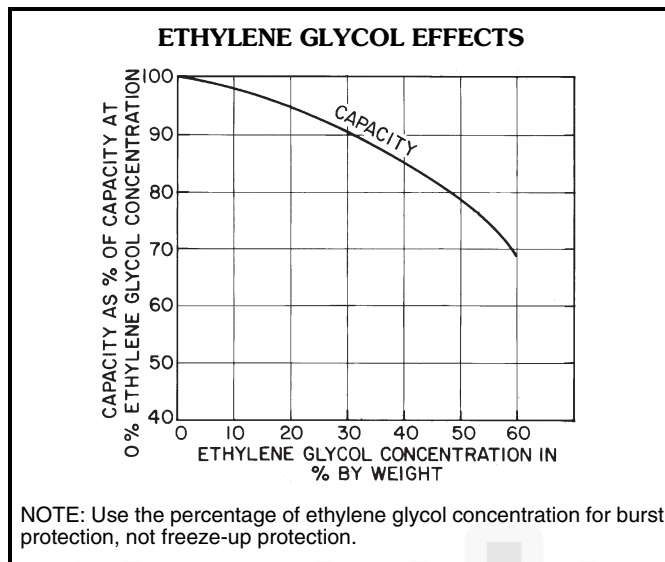

## Filters

Air is contaminated in varying degrees by soil, organic matter, spores, bacteria, smoke, dust, and fumes.

Air cleaning and filtration devices are required in order to create a clean work environment, reduce cleaning costs, and extend the life of machinery or equipment.

## Filter ratings (MERV)

Filters are rated according to efficiency and dust-holding capacity.

The most commonly accepted method of testing filter efficiency is per ASHRAE (American Society of Heating, Refrigerating and Air-Conditioning Engineers) Standard 52. An explanation of filter ratings can be found in Chapter 24 of the ASHRAE HVAC Systems and Equipment Handbook. ASHRAE standard 52.2 defines the minimum efficiency reporting value (MERV).

Filter dust-holding capacity is directly related to filter life. The filter is replaced when the amount of dirt and dust it contains builds up air resistance to an unacceptable level. Air resistance build-up is measured by a filter air-resistance gage.

# Selection procedure



## Size selection

This catalog has been designed to provide a quick and accurate means of selecting and specifying a central station air-handling unit. Start with the information you have: required airflow and preferred coil face velocity to select a nominal unit size. Contact your Carrier sales representative for the **AHUBuilder**® program. Next, refer to the component descriptions. NOTE: Carrier's **AHUBuilder** program provides exact coil and performance data certified to the AHRI 410 and 430 standards. In addition to standard outputs, the program provides coil moisture carryover information. When information from the computer selection programs is not available, use the following general guidelines for velocity limits to avoid moisture carryover.

COIL MOISTURE BLOWOFF LIMITS (fpm)			
FINS per Inch	ALUMINUM	COPPER	E-COAT
8	550	500	475
11	550	425	400
14	550	375	350

### NOTES:

1. See **AHUBuilder** program for specific limitations.
2. Data shown is for general use at 80 F dry bulb (db)/67 F wet bulb (wb) entering air, 55 db/55 wb (F) leaving air conditions.
3. Units apply to clean, properly maintained coils.

## Cost-efficient, computerized selection

The Products and Systems Electronic Catalog is a series of computer programs designed to run on an IBM-compatible personal computer to select products and systems offered by Carrier.

## General features:

- Provides “true” selection for all air-handling units coils and fans. Required capacity and/or entering and leaving conditions may be specified with the program determining performance ratings for all applicable coil configurations. User-specified performance rating for a particular configuration or specified performance criteria
- Guaranteed projection of unit size vs airflow without water carryover problems
- Minimized specifying input criteria — fixed or rarely changing parameters user specified as defaults and separated from main input screen
- Displayed output mode of coil performance ratings allow side-by-side comparison of user-defined performance ratings values (4 calculated values for each coil), or complete performance ratings of all coils in a spreadsheet format.
- Detailed summary reports including cooling, heating, fan, acoustic, and physical performance data can be generated in different formats. Fully featured on-line help system contained within the program
- Easier to use than previous generation systems
- Uses AHRI approved method, reduces engineering expense

**Special features** — Allows user to continually monitor and modify input/output. Provides processing for special application:

- Ethylene glycol or brine
- Altitude

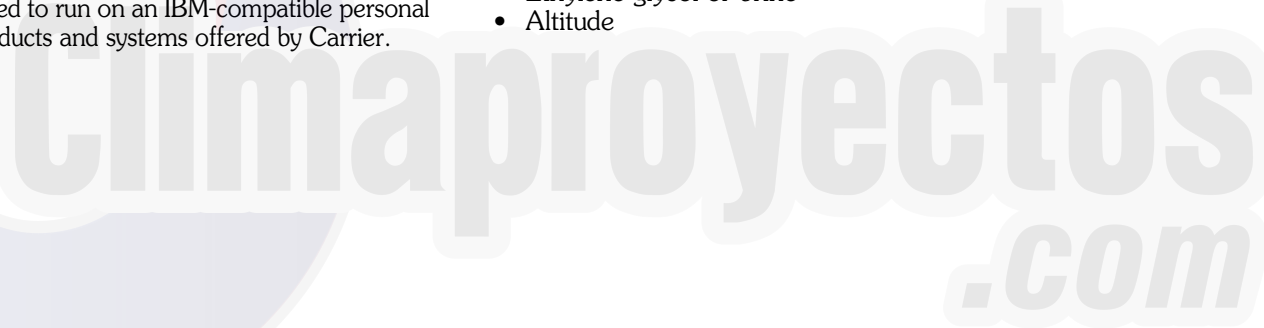

## Electric heat selection procedure

### I Determine electric heat requirements based on size of selected unit.

Given:

Air Quantity . . . . . 3,000 cfm  
 Entering-Air Temperature . . . . . 54 F  
 Leaving-Air Temperature . . . . . 77 F  
 Maximum Air Velocity . . . . . 650 fpm  
 Electric Service . . . . . 460-v, 3-ph, 60-Hz  
 Unit Type . . . . . Horizontal Draw-Thru

### II Determine heating load.

$$\begin{aligned} \text{Heating Load} &= 1.1 \times \text{Cfm} \times \text{Air Temp Rise} \\ &= 1.1 \times 3,000 \times 23 \\ &= 75,900 \text{ Btuh (75.9 MBtuh)} \end{aligned}$$

### III Verify unit size.

Size of the electric heating coil face area is usually predetermined by the selection of the air-handling unit and the cooling coil. However, the heater size must be checked to assure that the minimum face velocity is provided for the heater.

$$\begin{aligned} \text{Minimum Face Area} &= \frac{3,000}{650 \text{ Fpm}} \\ &= 4.6 \text{ sq ft} \end{aligned}$$

$$\begin{aligned} \text{Actual Face Velocity} &= \frac{3,000}{4.9 \text{ sq ft}} \quad (\text{Actual Coil Face Area}) \\ &= 615 \text{ Fpm} \end{aligned}$$

### IV Determine kilowatt equivalent of heating load.

$$\begin{aligned} \text{kW Heating Load} &= \frac{75.9 \text{ MBtuh}}{3.413 \text{ MBtuh/kW}} \\ &= \frac{75.9}{3.413} \\ &= 22.2 \text{ kW} \end{aligned}$$

### V Determine unit electric heater size.

Select the heater which has a kW rating closest to but greater than the required kW and is available at the required voltage. Electric heaters are available in one-kW increments. The Electric Heater Data on pages 46-49 shows incremental sizes only.

### VI Determine capacity of electric heater.

$$\begin{aligned} \text{Capacity} &= 23 \text{ kW} \times 3.413 \\ &= 78.5 \text{ MBtuh} \end{aligned}$$

### VII Calculate air temperature rise.

$$\begin{aligned} \text{Air Temp Rise} &= \frac{78,500 \text{ Btuh}}{1.1 \times 3,000 \text{ Cfm}} \\ &= 23.8 \text{ F} \end{aligned}$$

### VIII Calculate the actual leaving-air temperature.

$$\begin{aligned} \text{Leaving Air Temp} &= \text{Ent Air Temp} + \text{Air Temp Rise} \\ &= 54 + 23.8 \\ &= 77.8 \text{ F} \end{aligned}$$

### IX Determine air friction loss of electric heating coil.

Enter Component Pressure Drop table, page 48, and find (by interpolation) air friction loss of electric heater at 615 fpm to be 0.02 in. wg.

### X Voltage variations.

Variations from the rated voltage of the electric heating coils can significantly affect the coil's rated output. The effects of voltage variation can be determined by the following formula.

$$\text{kW}_a = \text{kW}_r \times \left( \frac{V_a}{V_r} \right)^2$$

$\text{kW}_a$  = Actual kW Output From Coil  
 $\text{kW}_r$  = Rated kW Output From Coil  
 $V_a$  = Actual Voltage at Coil  
 $V_r$  = Rated Voltage at Coil

### Air handler selection guide

1. Unit size = Coil face area (ft<sup>2</sup>) = design cfm/max face velocity  
 Example: 12,000 cfm/500 fpm = 24 → Size 25
2. Consider your system and choose the appropriate component sections.
3. Determine overall unit dimensions and weight. The height and width for any given unit size is the same for all component sections.
4. Finalize your selections using Carrier's latest version of the **AHUBuilder**® program. The **AHUBuilder** program is a comprehensive selection tool designed to help our customers quickly and efficiently make the proper air handler choice.

# Dimensions



→ **SIZE 03W (1500 cfm)**

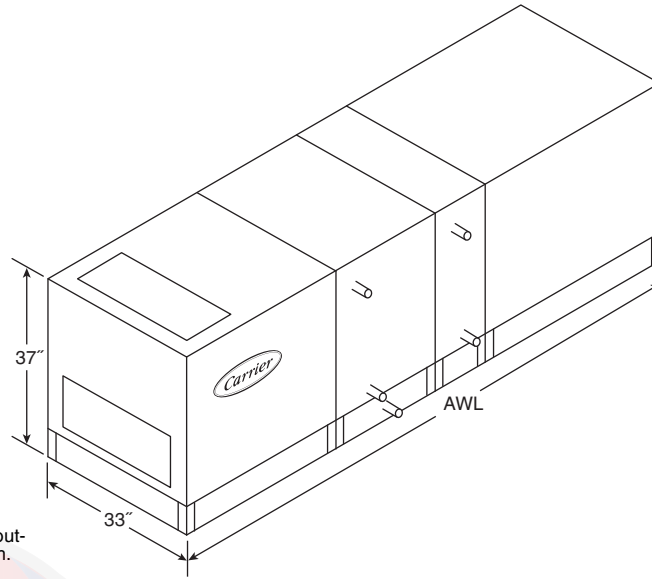

**NOTES:**

1. Dimensions are shown for indoor units. For outdoor units add 4 in. to height and 3 in. to width.
2. Height dimensions include 6-in. base rail.

AIR DISTRIBUTION COMPONENTS		AWL (in.)	Weight (lb)	DAMPER QUANTITY		
	Mixing Box	18	142	1		
	Side Inlet Mixing Box	21	158	1		
	Filter Mixing Box (2-in. or 4-in. Flat Filter)	25	222	1		
	Filter Mixing Box (6-in. Flat Filter)	27	231	1		
	Filter Mixing Box (Angle Filter)	36	274	1		
	Filter Mixing Box (Bag Cartridge Filter)	38	284	1		
	Air Mixer	18	167	N/A		
	Exhaust Box	18	159	1		
	Side Outlet Exhaust Box	21	171	1		
	Internal Face and Bypass Damper	18	137	1		
	External Face and Bypass Damper Section	18	219	1		
FILTRATION COMPONENTS		AWL (in.)	Weight (lb)	FILTER QUANTITY	FILTER SIZE (in.)	FILTER AREA (ft <sup>2</sup> )
	2-in. or 4-in. Flat Filter	12	189	1	25 x 20	3.5
	2-in. Pre-Filter with 4-in. Flat Filter	14	195	1	25 x 20	3.5
	2-in. or 4-in. Angle Filter	24	224	2	16 x 25	5.6
	Short Bag/Side Loading Cartridge Filter	24	228	1	24 x 24	4.0
	Long Bag/Side Loading Cartridge Filter	42	282	1	24 x 24	4.0
	Bag/Front Loading Cartridge Filter	48	301	1	24 x 24	4.0
	Blow-thru Front Loading HEPA Filter	48	301	1	24 x 24	4.0
HEAT TRANSFER SECTIONS		MIN AWL (in.)	MIN Weight (lb)	MAX AWL (in.)	MAX Weight (lb)	
	Coil and Variable Length Plenum (with Drain Pan)	24	155	61	275	
	Coil and Variable Length Plenum (without Drain Pan)	12	119	60	264	
	Dual Coil and Variable Length Plenum (with Drain Pan)	24	155	61	275	
	Vertical Coil	42	216	N/A	N/A	
	Internal Face and Bypass Cooling Coil	24	155	N/A	N/A	
	Internal Face and Bypass Heating Coil	12	119	24	155	
	Electric Heat with Control Box (Low Amp [min]/High Amp [max])	24	196	36	232	
AIR MOVEMENT SECTIONS**		MIN AWL (in.)*	MIN Weight (lb)*	MAX AWL (in.)†	MAX Weight (lb)†	
	Airfoil Fan	39	559	39	588	
	Downblast Airfoil Fan	39	559	39	588	
	Forward Curved Fan	24	512	24	557	
	Belt-Drive Plenum Fan	48	602	48	632	
	Direct Drive Plenum Fan	34	302	39	372	
	Vertical Forward Curve Fan	42	587	42	632	
	Vertical Airfoil Fan	42	581	42	611	
MISCELLANEOUS SECTIONS		MIN AWL (in.)	MIN Weight (lb)	MAX AWL (in.)	MAX Weight (lb)	
	ERV Section	103	1676	N/A	N/A	
	Humidifier	24	254	48	326	
	Access and Plenum	12	121	48	230	
	Turning Plenum	24	169	N/A	N/A	

**LEGEND**

- AWL — Airway Length
- ERV — Energy Recovery Ventilator
- DA — Duct Depth
- DW — Duct Width

\* Refer to **AHUBuilder®** program for application specific weight and AWL.  
 † Maximum is based on largest motor and largest fan wheel combination.  
 \*\* Minimum is based on smallest motor and smallest fan wheel combination.

→ **SIZE 06W (3000 cfm)**

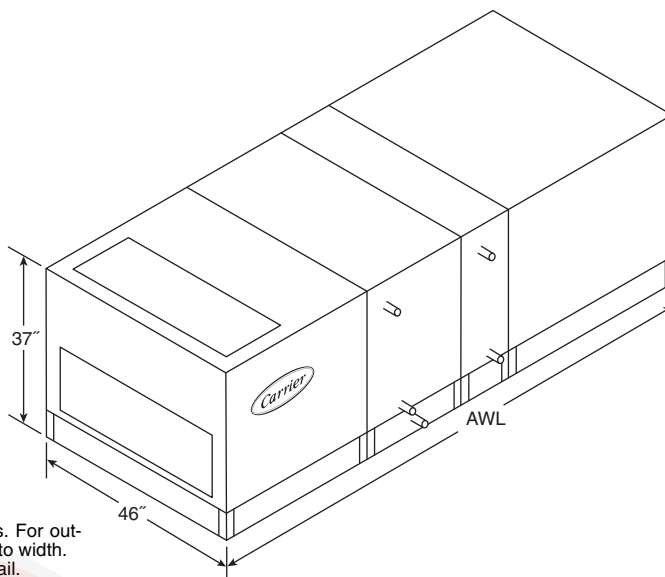

**NOTES:**

1. Dimensions are shown for indoor units. For outdoor units add 4 in. to height and 3 in. to width.
2. Height dimensions include 6-in. base rail.

AIR DISTRIBUTION COMPONENTS		AWL (in.)	Weight (lb)	DAMPER QUANTITY		
	Mixing Box	21	169	1		
	Side Inlet Mixing Box	27	198	1		
	Filter Mixing Box (2-in. or 4-in. Flat Filter)	28	279	1		
	Filter Mixing Box (6-in Flat Filter)	30	290	1		
	Filter Mixing Box (Angle Filter)	36	323	1		
	Filter Mixing Box (Bag Cartridge Filter)	41	351	1		
	Air Mixer	18	198	N/A		
	Exhaust Box	21	192	1		
	Side Outlet Exhaust Box	27	214	1		
	Internal Face and Bypass Damper	18	156	1		
	External Face and Bypass Damper Section	21	291	1		
	Multizone Damper (Front Discharge) (Two Deck)	5	90	N/A		
	Multizone Damper (Top Discharge) (Two Deck)	5 (height)	90	N/A		
FILTRATION COMPONENTS		AWL (in.)	Weight (lb)	FILTER QUANTITY	FILTER SIZE (in.)	FILTER AREA (ft <sup>2</sup> )
	2-in. or 4-in. Flat Filter	12	227	2	25 x 20	6.9
	2-in. Pre-Filter with 4-in. Flat Filter	14	234	2	25 x 20	6.9
	2-in. or 4-in. Angle Filter	24	269	4	16 x 20	8.9
	Short Bag/Side Loading Cartridge Filter	24	273	1 / 1	24 x 24 / 24 x 12	6.0
	Long Bag/Side Loading Cartridge Filter	42	336	1 / 1	24 x 24 / 24 x 12	6.0
	Bag/Front Loading Cartridge Filter	48	357	1 / 1	24 x 24 / 24 x 12	6.0
	Blow-thru Front Loading HEPA Filter	48	357	1 / 1	24 x 24 / 24 x 12	6.0
HEAT TRANSFER SECTIONS		MIN AWL (in.)	MIN Weight (lb)	MAX AWL (in.)	MAX Weight (lb)	Zones
	Coil and Variable Length Plenum (with Drain Pan)	24	177	61	318	
	Coil and Variable Length Plenum (without Drain Pan)	12	135	60	303	
	Dual Coil and Variable Length Plenum (with Drain Pan)	24	177	61	318	
	Vertical Coil	42	245	N/A	N/A	
	Multizone Front Discharge	49	629	N/A	N/A	6 zones
	Multizone Top Discharge	49	599	N/A	N/A	6 zones
	Internal Face and Bypass Cooling Coil	24	177	N/A	N/A	
	Internal Face and Bypass Heating Coil	12	135	24	177	
	Integral Face and Bypass Heating Coil	48	265	N/A	N/A	
	Electric Heat with Control Box (Low Amp [min]/High Amp [max])	30	264	36	285	
	Gas Heat (Low BTU [min]/High BTU [max])	61	498	97	871	
AIR MOVEMENT SECTIONS**		MIN AWL (in.)*	MIN Weight (lb)*	MAX AWL (in.)†	MAX Weight (lb)†	
	Airfoil Fan	39	674	40	700	
	Downblast Airfoil Fan	39	670	40	700	
	Forward Curved Fan	30	654	30	667	
	Belt-Drive Plenum Fan	54	763	54	820	
	Direct Drive Plenum Fan	36	405	43	520	
	Vertical Forward Curve Fan	42	696	42	734	
	Vertical Airfoil Fan	42	696	42	727	
MISCELLANEOUS SECTIONS		MIN AWL (in.)	MIN Weight (lb)	MAX AWL (in.)	MAX Weight (lb)	
	ERV Section	103	1987	103	2086	
	Humidifier	24	295	48	379	
	Access and Plenum	12	139	48	264	
	Turning Plenum	24	195	N/A	N/A	

**LEGEND**

- AWL — Airway Length
- ERV — Energy Recovery Ventilator
- DA — Duct Depth
- DW — Duct Width

\* Refer to **AHUBuilder®** program for application specific weight and AWL.  
 † Maximum is based on largest motor and largest fan wheel combination.  
 \*\* Minimum is based on smallest motor and smallest fan wheel combination.

# Dimensions (cont)



→ **SIZE 08W (4000 cfm)**

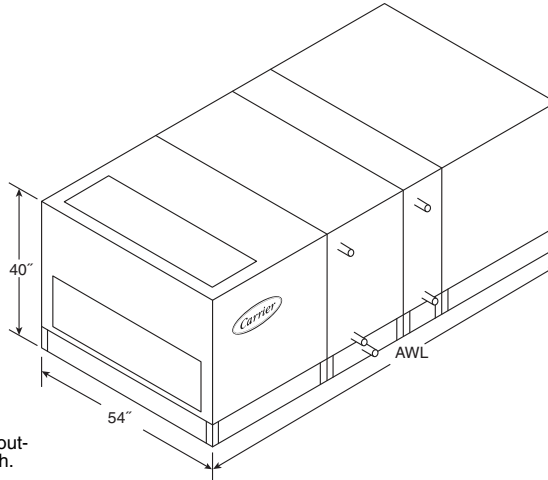

**NOTES:**

1. Dimensions are shown for indoor units. For outdoor units add 4 in. to height and 3 in. to width.
2. Height dimensions include 6-in. base rail.

AIR DISTRIBUTION COMPONENTS		AWL (in.)	Weight (lb)	DAMPER QUANTITY		
Mixing Box		21	188	1		
Side Inlet Mixing Box		27	223	1		
Filter Mixing Box (2-in. or 4-in. Flat Filter)		28	317	1		
Filter Mixing Box (6-in. Flat Filter)		30	329	1		
Filter Mixing Box (Angle Flat Filter)		36	365	1		
Filter Mixing Box (Bag Cartridge Flat Filter)		41	396	1		
Air Mixer		18	224	N/A		
Exhaust Box		21	213	1		
Side Outlet Exhaust Box		27	238	1		
Combination Exhaust Mixing Box		27	207	1		
Internal Face and Bypass Damper		18	172	1		
External Face and Bypass Damper Section		21	336	1		
Multizone Damper (Front Discharge) (Two Deck)		5	105	N/A		
Multizone Damper (Top Discharge) (Two Deck)	5 (height)		104	N/A		
FILTRATION COMPONENTS		AWL (in.)	Weight (lb)	FILTER QUANTITY	FILTER SIZE (in.)	FILTER AREA (ft <sup>2</sup> )
2-in. or 4-in. Flat Filter		12	255	3	25 x 16	8.3
2-in. Pre-Filter with 4-in. Flat Filter		14	263	3	25 x 16	8.3
2-in. or 4-in. Angle Filter		24	302	4	16 x 25	11.1
Short Bag/Side Loading Cartridge Filter		24	306	2	24 x 24	8.0
Long Bag/Side Loading Cartridge Filter		42	377	2	24 x 24	8.0
Bag/Front Loading Cartridge Filter		48	400	2	24 x 24	8.0
Blow-thru Front Loading HEPA Filter		48	400	2	24 x 24	8.0
HEAT TRANSFER SECTIONS		MIN AWL (in.)	MIN Weight (lb)	MAX AWL (in.)	MAX Weight (lb)	Zones
Coil and Variable Length Plenum (with Drain Pan)		24	195	61	353	
Coil and Variable Length Plenum (without Drain Pan)		12	148	60	336	
Dual Coil and Variable Length Plenum (with Drain Pan)		24	195	61	353	
Vertical Coil		36	253	N/A	N/A	
Multizone Front Discharge		49	694	N/A	N/A	7 zones
Multizone Top Discharge		49	658	N/A	N/A	7 zones
Internal Face and Bypass Cooling Coil		24	195	N/A	N/A	
Internal Face and Bypass Heating Coil		12	148	24	195	
Integral Face and Bypass Heating Coil		48	293	N/A	N/A	
Electric Heat with Control Box (Low Amp [min]/High Amp [max])		30	301	42	348	
Gas Heat (Low BTU [min]/High BTU [max])		85	800	121	1216	
AIR MOVEMENT SECTIONS**		MIN AWL (in.)*	MIN Weight (lb)*	MAX AWL (in.)†	MAX Weight (lb)†	
Airfoil Fan		40	772	40	795	
Downblast Airfoil Fan		40	761	40	823	
Forward Curved Fan		36	799	36	755	
Belt-Drive Plenum Fan		54	844	42	859	
Direct Drive Plenum Fan		38	462	46	706	
Fan Array		37	514	39	700	
Vertical Forward Curve Fan		36	784	36	784	
Vertical Airfoil Fan		36	771	36	829	
MISCELLANEOUS SECTIONS		MIN AWL (in.)	MIN Weight (lb)	MAX AWL (in.)	MAX Weight (lb)	
ERV Section		109	2328	109	2463	
Humidifier		24	325	48	419	
Access and Plenum		12	152	48	293	
Turning Plenum		24	218	N/A	N/A	

**LEGEND**

- AWL — Airway Length
- ERV — Energy Recovery Ventilator
- DA — Duct Depth
- DW — Duct Width

† Maximum is based on largest motor and largest fan wheel combination.

\*\* Minimum is based on smallest motor and smallest fan wheel combination.

\* Refer to **AHUBuilder®** program for application specific weight and AWL.

→ **SIZE 10W (5000 cfm)**

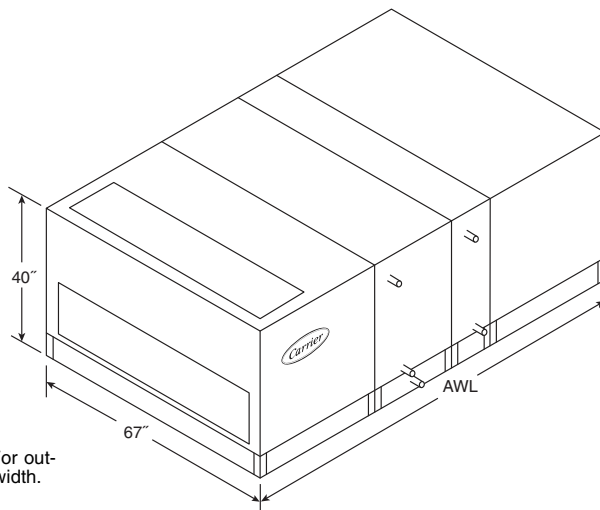

**NOTES:**

1. Dimensions are shown for indoor units. For outdoor units add 4 in. to height and 3 in. to width.
2. Height dimensions include 6-in. base rail.

<b>AIR DISTRIBUTION COMPONENTS</b>	<b>AWL (in.)</b>	<b>Weight (lb)</b>	<b>DAMPER QUANTITY</b>		
Mixing Box	21	210	1		
Side Inlet Mixing Box	33	277	1		
Filter Mixing Box (2" or 4" Flat Filter)	28	356	1		
Filter Mixing Box (6" Flat Filter)	30	370	1		
Filter Mixing Box (Angle Filter)	36	410	1		
Filter Mixing Box (Bag Cartridge Filter)	41	445	1		
Air Mixer	24	281	N/A		
Exhaust Box	21	236	1		
Side Outlet Exhaust Box	33	291	1		
Combination Exhaust Mixing Box	33	231	1		
Internal Face and Bypass Damper	18	191	1		
External Face and Bypass Damper	21	384	1		
Multizone Damper (Front Discharge) (Two Deck)	5	118	N/A		
Multizone Damper (Top Discharge) (Two Deck)	5 (height)	118	N/A		
<b>FILTRATION COMPONENTS</b>	<b>AWL (in.)</b>	<b>Weight (lb)</b>	<b>FILTER QUANTITY</b>	<b>FILTER SIZE (in.)</b>	<b>FILTER AREA (ft<sup>2</sup>)</b>
2-in. or 4-in. Flat Filter	12	286	3	25 x 20	10.4
2-in. Pre-Filter with 4-in. Flat Filter	14	295	3	25 x 20	10.4
2-in. or 4-in. Angle Filter	24	339	6	16 x 20	13.3
Short Bag/Side Loading Cartridge Filter	24	343	1 / 1	24 x 24 / 24 x 12	10.0
Long Bag/Side Loading Cartridge Filter	42	422	1 / 1	24 x 24 / 24 x 12	10.0
Bag/Front Loading Cartridge Filter	48	449	2 / 1	24 x 24 / 24 x 12	10.0
Blow-thru Front Loading HEPA Filter	48	449	2 / 1	24 x 24 / 24 x 12	10.0
<b>HEAT TRANSFER SECTIONS</b>	<b>MIN AWL (in.)</b>	<b>MIN Weight (lb)</b>	<b>MAX AWL (in.)</b>	<b>MAX Weight (lb)</b>	<b>Zones</b>
Coil and Variable Length Plenum (with Drain Pan)	24	217	61	403	
Coil and Variable Length Plenum (without Drain Pan)	12	165	60	390	
Dual Coil and Variable Length Plenum (with Drain Pan)	24	217	61	403	
Vertical Coil	36	281	N/A	N/A	
Multizone Front Discharge	49	901	N/A	N/A	10 zones
Multizone Top Discharge	49	853	N/A	N/A	10 zones
Internal Face and Bypass Cooling Coil	24	217	N/A	N/A	
Internal Face and Bypass Heating Coil	12	165	24	217	
Integral Face and Bypass Heating Coil	48	327	N/A	N/A	
Electric Heat with Control Box (Low Amp [min]/High Amp [max])	30	344	42	397	
Gas Heat (Low BTU [min]/High BTU [max])	85	903	121	1359	
<b>AIR MOVEMENT SECTIONS**</b>	<b>MIN AWL (in.)*</b>	<b>MIN Weight (lb)*</b>	<b>MAX AWL (in.)†</b>	<b>MAX Weight (lb)†</b>	
Airfoil Fan	40	849	34	887	
Downblast Airfoil Fan	40	849	34	887	
Forward Curved Fan	36	874	36	830	
Belt-Drive Plenum Fan	42	899	42	1072	
Direct Drive Plenum Fan	42	555	48	785	
Fan Array	37	578	41	785	
Vertical Forward Curve Fan	36	867	36	912	
Vertical Airfoil Fan	36	848	36	932	
<b>MISCELLANEOUS SECTIONS</b>	<b>MIN AWL (in.)</b>	<b>MIN Weight (lb)</b>	<b>MAX AWL (in.)</b>	<b>MAX Weight (lb)</b>	
ERV Section	109	2563	128	2891	
Humidifier	24	360	48	465	
Access and Plenum	12	169	48	327	
Turning Plenum	24	244	N/A	N/A	

**LEGEND**

- AWL** — Airway Length
- ERV** — Energy Recovery Ventilator
- DA** — Duct Depth
- DW** — Duct Width

\* Refer to **AHUBuilder®** program for application specific weight and AWL.  
 † Maximum is based on largest motor and largest fan wheel combination.  
 \*\* Minimum is based on smallest motor and smallest fan wheel combination.

# Dimensions (cont)



→ **SIZE 12W (6000 cfm)**

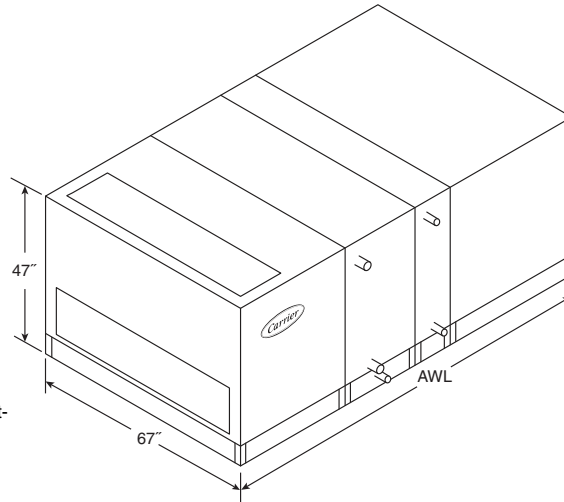

**NOTES:**

1. Dimensions are shown for indoor units. For outdoor units add 4 in. to height and 3 in. to width.
2. Height dimensions include 6-in. base rail.

AIR DISTRIBUTION COMPONENTS	AWL (in.)	Weight (lb)	DAMPER QUANTITY		
Mixing Box	21	227	1		
Side Inlet Mixing Box	33	293	1		
Filter Mixing Box (2-in. or 4-in. Flat Filter)	28	391	1		
Filter Mixing Box (6-in. Flat Filter)	30	406	1		
Filter Mixing Box (Angle Filter)	36	448	1		
Filter Mixing Box (Bag Cartridge Filter)	41	484	1		
Air Mixer	24	303	N/A		
Exhaust Box	21	251	1		
Side Outlet Exhaust Box	33	305	1		
Combination Exhaust Mixing Box	33	250	1		
Internal Face and Bypass Damper	18	199	1		
External Face and Bypass Damper Section	21	425	1		
Multizone Damper (Front Discharge) (Two Deck)	5	132	N/A		
Multizone Damper (Top Discharge) (Two Deck)	5 (height)	132	N/A		
FILTRATION COMPONENTS	AWL (in.)	Weight (lb)	FILTER QUANTITY	FILTER SIZE (in.)	FILTER AREA (ft <sup>2</sup> )
2-in. or 4-in. Flat Filter	12	309	6	16 x 20	13.3
2-in. Pre-Filter with 4-in. Flat Filter	14	318	6	16 x 20	13.3
2-in. or 4-in. Angle Filter	24	364	6	20 x 20	16.7
Short Bag/Side Loading Cartridge Filter	24	369	2 / 3	24 x 24 / 24 x 12	14.0
Long Bag/Side Loading Cartridge Filter	42	453	2 / 3	24 x 24 / 24 x 12	14.0
Bag/Front Loading Cartridge Filter	48	481	2 / 2	24 x 24 / 24 x 12	12.0
Blow-thru Front Loading HEPA Filter	48	481	2 / 2	24 x 24 / 24 x 12	12.0
HEAT TRANSFER SECTIONS	MIN AWL (in.)	MIN Weight (lb)	MAX AWL (in.)	MAX Weight (lb)	Zones
Coil and Variable Length Plenum (with Drain Pan)	24	227	61	423	
Coil and Variable Length Plenum (without Drain Pan)	12	171	60	409	
Dual Coil and Variable Length Plenum (with Drain Pan)	24	227	61	423	
Vertical Coil	42	325	N/A	N/A	
Multizone Front Discharge	61	913	N/A	N/A	10 zones
Multizone Top Discharge	61	840	N/A	N/A	10 zones
Internal Face and Bypass Cooling Coil	24	227	N/A	N/A	
Internal Face and Bypass Heating Coil	12	171	24	227	
Integral Face and Bypass Heating Coil	48	344	N/A	N/A	
Electric Heat with Control Box (Low Amp [min]/High Amp [max])	30	371	42	427	
Gas Heat (Low BTU [min]/High BTU [max])	85	947	121	1440	
AIR MOVEMENT SECTIONS**	MIN AWL (in.)*	MIN Weight (lb)*	MAX AWL (in.)†	MAX Weight (lb)†	
Airfoil Fan	34	929	40	1089	
Downblast Airfoil Fan	37	888	43	1104	
Forward Curved Fan	42	970	42	969	
Belt-Drive Plenum Fan	48	998	48	1141	
Direct Drive Plenum Fan	42	610	50	857	
Fan Array	40	648	43	864	
Vertical Forward Curve Fan	42	976	42	1020	
Vertical Airfoil Fan	42	968	42	1149	
MISCELLANEOUS SECTIONS	MIN AWL (in.)	MIN Weight (lb)	MAX AWL (in.)	MAX Weight (lb)	
ERV Section	109	2815	131	3175	
Humidifier	24	382	48	493	
Access and Plenum	12	176	48	343	
Turning Plenum	24	262	N/A	N/A	

**LEGEND**

- AWL — Airway Length
- ERV — Energy Recovery Ventilator
- DA — Duct Depth
- DW — Duct Width

\* Refer to **AHUBuilder®** program for application specific weight and AWL.

† Maximum is based on largest motor and largest fan wheel combination.

\*\* Minimum is based on smallest motor and smallest fan wheel combination.



→ **SIZE 14W (7000 cfm)**

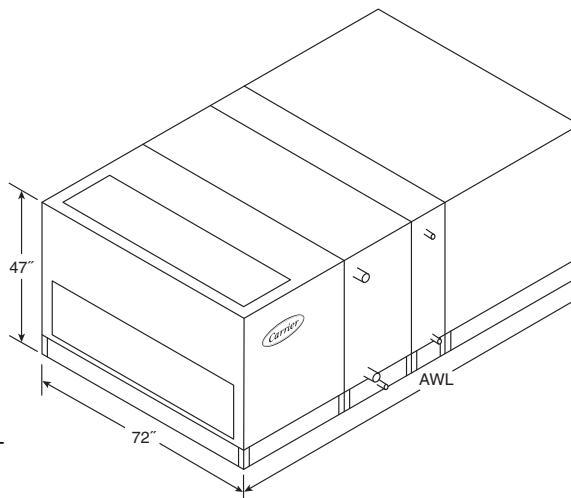

**NOTES:**

1. Dimensions are shown for indoor units. For outdoor units add 4 in. to height and 3 in. to width.
2. Height dimensions include 6-in. base rail.

AIR DISTRIBUTION COMPONENTS		AWL (in.)	Weight (lb)	DAMPER QUANTITY		
	Mixing Box	24	243	2		
	Side Inlet Mixing Box	39	332	1		
	Filter Mixing Box (2-in. or 4-in. Flat Filter)	31	431	2		
	Filter Mixing Box (6-in. Flat Filter)	33	446	2		
	Filter Mixing Box (Angle Filter)	36	468	2		
	Filter Mixing Box (Bag Cartridge Filter)	44	528	2		
	Air Mixer	24	318	N/A		
	Exhaust Box	24	274	2		
	Side Outlet Exhaust Box	39	346	1		
	Combination Exhaust Mixing Box	39	268	1		
	Internal Face and Bypass Damper	18	207	2		
	External Face and Bypass Damper Section	24	473	2		
	Multizone Damper (Front Discharge) (Two Deck)	5	146	N/A		
	Multizone Damper (Top Discharge) (Two Deck)	5 (height)	147	N/A		
FILTRATION COMPONENTS		AWL (in.)	Weight (lb)	FILTER QUANTITY	FILTER SIZE (in.)	FILTER AREA (ft <sup>2</sup> )
	2-in. or 4-in. Flat Filter	12	330	3 / 3	16 x 20 / 20 x 20	15.0
	2-in. Pre-Filter with 4-in. Flat Filter	14	340	3 / 3	16 x 20 / 20 x 20	15.0
	2-in. or 4-in. Angle Filter	24	388	4 / 2	20 x 24 / 20 x 20	18.9
	Short Bag/Side Loading Cartridge Filter	24	393	2 / 3	24 x 24 / 24 x 12'	14.0
	Long Bag/Side Loading Cartridge Filter	42	480	2 / 3	24 x 24 / 24 x 12'	14.0
	Bag/Front Loading Cartridge Filter	48	509	2 / 3	24 x 24 / 24 x 12'	14.0
	Blow-thru Front Loading HEPA Filter	48	509	2 / 3	24 x 24 / 24 x 12'	14.0
HEAT TRANSFER SECTIONS		MIN AWL (in.)	MIN Weight (lb)	MAX AWL (in.)	MAX Weight (lb)	Zones
	Coil and Variable Length Plenum (with Drain Pan)	24	236	61	439	
	Coil and Variable Length Plenum (without Drain Pan)	12	178	60	424	
	Dual Coil and Variable Length Plenum (with Drain Pan)	24	236	61	439	
	Vertical Coil	48	360	N/A	N/A	
	Multizone Front Discharge	61	951	N/A	N/A	10 zones
	Multizone Top Discharge	61	872	N/A	N/A	10 zones
	Internal Face and Bypass Cooling Coil	24	236	N/A	N/A	
	Internal Face and Bypass Heating Coil	12	178	24	236	
	Integral Face and Bypass Heating Coil	48	357	N/A	N/A	
	Electric Heat with Control Box (Low Amp [min]/High Amp [max])	32	396	42	454	
	Gas Heat (Low BTU [min]/High BTU [max])	85	978	121	1594	
AIR MOVEMENT SECTIONS**		MIN AWL (in.)*	MIN Weight (lb)*	MAX AWL (in.)†	MAX Weight (lb)†	
	Airfoil Fan	34	984	46	1104	
	Downblast Airfoil Fan	37	999	49	1159	
	Forward Curved Fan	48	1055	48	1054	
	Belt-Drive Plenum Fan	48	1059	48	1202	
	Direct Drive Plenum Fan	46	662	51	913	
	Fan Array	38	705	43	885	
	Vertical Forward Curve Fan	48	1066	48	1110	
	Vertical Airfoil Fan	48	1114	48	1209	
MISCELLANEOUS SECTIONS		MIN AWL (in.)	MIN Weight (lb)	MAX AWL (in.)	MAX Weight (lb)	
	ERV Section	115	3157	142	3524	
	Humidifier	24	403	48	519	
	Access and Plenum	12	183	48	356	
	Turning Plenum	24	273	N/A	N/A	

**LEGEND**

- AWL** — Airway Length
- ERV** — Energy Recovery Ventilator
- DA** — Duct Depth
- DW** — Duct Width

\* Refer to **AHUBuilder®** program for application specific weight and AWL.  
 † Maximum is based on largest motor and largest fan wheel combination.  
 \*\* Minimum is based on smallest motor and smallest fan wheel combination.

# Dimensions (cont)



→ **SIZE 16T (8000 cfm)**

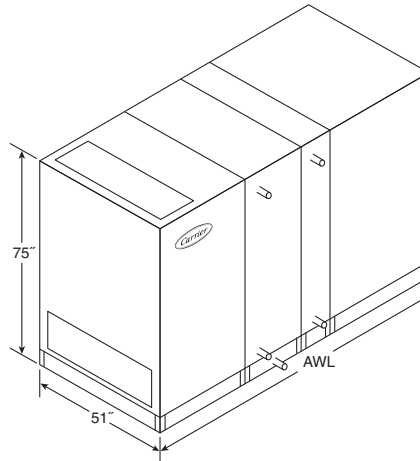

**NOTES:**

1. Dimensions are shown for indoor units. For outdoor units add 4 in. to height and 3 in. to width.
2. Height dimensions include 6-in. base rail.

AIR DISTRIBUTION COMPONENTS	AWL (in.)	Weight (lb)	DAMPER QUANTITY
Mixing Box	33	273	1
Side Inlet Mixing Box	27	367	2
Filter Mixing Box (2-in. or 4-in. Flat Filter)	40	502	1
Filter Mixing Box (6-in. Flat Filter)	42	517	1
Filter Mixing Box (Angle Filter)	41	509	1
Filter Mixing Box (Bag Cartridge Filter)	53	604	1
Air Mixer	24	363	N/A
Exhaust Box	33	308	1
Side Outlet Exhaust Box	27	380	2
Combination Exhaust Mixing Box	27	301	2
Internal Face and Bypass Damper	18	224	1
External Face and Bypass Damper Section	33	532	1
Multizone Damper (Front Discharge) (Two Deck)			Future offering
Multizone Damper (Top Discharge) (Two Deck)			Future offering

FILTRATION COMPONENTS	AWL (in.)	Weight (lb)	FILTER QUANTITY	FILTER SIZE (in.)	FILTER AREA (ft <sup>2</sup> )
2-in. or 4-in. Flat Filter	12	364	6	20 x 20	16.7
2-in. Pre-Filter with 4-in. Flat Filter	14	374	6	20 x 20	16.7
2-in. or 4-in. Angle Filter	26	424	8	20 x 20	22.2
Short Bag/Side Loading Cartridge Filter	24	432	2 / 3	24 x 24 / 12 x 24	14.0
Long Bag/Side Loading Cartridge Filter	42	523	2 / 3	24 x 24 / 12 x 24	14.0
Bag/Front Loading Cartridge Filter	48	554	2 / 3	24 x 24 / 12 x 24	14.0
Blow-thru Front Loading HEPA Filter	48	554	2 / 3	24 x 24 / 12 x 24	14.0

HEAT TRANSFER SECTIONS	MIN AWL (in.)	MIN Weight (lb)	MAX AWL (in.)	MAX Weight (lb)
Coil and Variable Length Plenum (with Drain Pan)	24	255	61	473
Coil and Variable Length Plenum (without Drain Pan)	12	194	60	450
Dual Coil and Variable Length Plenum (with Drain Pan)	24	255	61	473
Vertical Coil				Future offering
Multizone Front Discharge				Future offering
Multizone Top Discharge				Future offering
Internal Face and Bypass Cooling Coil	12	255	N/A	N/A
Internal Face and Bypass Heating Coil	14	194	24	254
Integral Face and Bypass Heating Coil				Future offering
Electric Heat with Control Box (Low Amp [min]/High Amp [max])	30	431	42	461
Gas Heat (Low BTU [min]/High BTU [max])				Future offering

AIR MOVEMENT SECTIONS**	MIN AWL (in.)*	MIN Weight (lb)*	MAX AWL (in.)†	MAX Weight (lb)†
Airfoil Fan	53	1125	61	1141
Downblast Airfoil Fan	56	1137	64	1253
Forward Curved Fan	49	1155	54	1164
Belt-Drive Plenum Fan				Future offering
Direct Drive Plenum Fan	46	783	51	1068
Fan Array				Future offering
Vertical Forward Curve Fan				Future offering
Vertical Airfoil Fan				Future offering

MISCELLANEOUS SECTIONS	MIN AWL (in.)	MIN Weight (lb)	MAX AWL (in.)	MAX Weight (lb)
ERV Section				Future offering
Humidifier	24	428	48	546
Access and Plenum	12	428	48	378
Turning Plenum	24	317	N/A	N/A

**LEGEND**

- AWL — Airway Length
- ERV — Energy Recovery Ventilator
- DA — Duct Depth
- DW — Duct Width

\* Refer to **AHUBuilder®** program for application specific weight and AWL.  
 † Maximum is based on largest motor and largest fan wheel combination.  
 \*\* Minimum is based on smallest motor and smallest fan wheel combination.

→ **SIZE 17W (8500 cfm)**

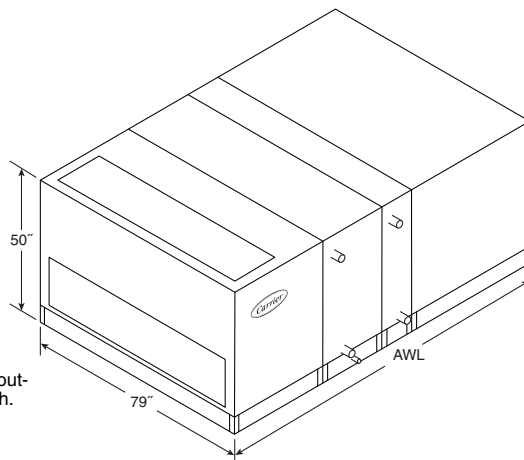

**NOTES:**

1. Dimensions are shown for indoor units. For outdoor units add 4 in. to height and 3 in. to width.
2. Height dimensions include 6-in. base rail.

AIR DISTRIBUTION COMPONENTS	AWL (in.)	Weight (lb)	DAMPER QUANTITY		
Mixing Box	24	264	2		
Side Inlet Mixing Box	39	360	2		
Filter Mixing Box (2-in. or 4-in. Flat Filter)	31	479	2		
Filter Mixing Box (6-in. Flat Filter)	33	495	2		
Filter Mixing Box (Angle Filter)	36	518	2		
Filter Mixing Box (Bag Cartridge Filter)	44	582	2		
Air Mixer	30	380	N/A		
Exhaust Box	24	297	2		
Side Outlet Exhaust Box	39	375	2		
Combination Exhaust Mixing Box	39	291	2		
Internal Face and Bypass Damper	18	221	2		
External Face and Bypass Damper Section	24	534	2		
Multizone Damper (Front Discharge) (Two Deck)	5	168	N/A		
Multizone Damper (Top Discharge) (Two Deck)	5 (height)	168	N/A		
FILTRATION COMPONENTS	AWL (in.)	Weight (lb)	FILTER QUANTITY	FILTER SIZE (in.)	FILTER AREA (ft <sup>2</sup> )
2-in. or 4-in. Flat Filter	12	364	6	20 x 20	16.7
2-in. Pre-Filter with 4-in. Flat Filter	14	375	6	20 x 20	16.7
2-in. or 4-in. Angle Filter	24	427	12	12 x 24	24.0
Short Bag/Side Loading Cartridge Filter	24	432	3 / 3	24 x 24 / 24 x 12	18.0
Long Bag/Side Loading Cartridge Filter	42	526	3 / 3	24 x 24 / 24 x 12	18.0
Bag/Front Loading Cartridge Filter	48	557	3 / 3	24 x 24 / 24 x 12	18.0
Blow-thru Front Loading HEPA Filter	48	557	3 / 3	24 x 24 / 24 x 12	18.0
HEAT TRANSFER SECTIONS	MIN AWL (in.)	MIN Weight (lb)	MAX AWL (in.)	MAX Weight (lb)	Zones
Coil and Variable Length Plenum (with Drain Pan)	24	252	61	471	
Coil and Variable Length Plenum (without Drain Pan)	12	189	60	454	
Dual Coil and Variable Length Plenum (with Drain Pan)	24	252	61	471	
Vertical Coil	48	389	N/A	N/A	
Multizone Front Discharge	61	1015	N/A	N/A	12 zones
Multizone Top Discharge	61	931	N/A	N/A	12 zones
Internal Face and Bypass Cooling Coil	24	252	N/A	N/A	
Internal Face and Bypass Heating Coil	12	189	24	252	
Integral Face and Bypass Heating Coil	48	382	N/A	N/A	
Electric Heat with Control Box (Low Amp [min]/High Amp [max])	32	438	42	500	
Gas Heat (Low BTU [min]/High BTU [max])	85	1075	121	1721	
AIR MOVEMENT SECTIONS**	MIN AWL (in.)*	MIN Weight (lb)*	MAX AWL (in.)†	MAX Weight (lb)†	
Airfoil Fan	46	1160	46	1237	
Downblast Airfoil Fan	49	1158	49	1253	
Forward Curved Fan	48	1277	48	1149	
Belt-Drive Plenum Fan	48	1207	48	1306	
Direct Drive Plenum Fan	49	812	57	1085	
Fan Array	39	788	46	1227	
Vertical Forward Curve Fan	48	1213	48	1214	
Vertical Airfoil Fan	48	1162	48	1312	
MISCELLANEOUS SECTIONS	MIN AWL (in.)	MIN Weight (lb)	MAX AWL (in.)	MAX Weight (lb)	
ERV Section	121	3514	147	3929	
Humidifier	24	437	48	562	
Access and Plenum	12	195	48	382	
Turning Plenum	24	296	N/A	N/A	

**LEGEND**

- AWL — Airway Length
- ERV — Energy Recovery Ventilator
- DA — Duct Depth
- DW — Duct Width

\* Refer to **AHUBuilder®** program for application specific weight and AWL.  
 † Maximum is based on largest motor and largest fan wheel combination.  
 \*\* Minimum is based on smallest motor and smallest fan wheel combination.

# Dimensions (cont)



→ **SIZE 18T (9000 cfm)**

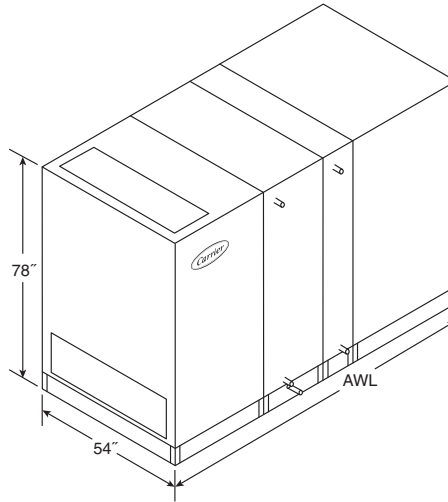

- NOTES:  
 1. Dimensions are shown for indoor units. For outdoor units add 4 in. to height and 3 in. to width.  
 2. Height dimensions include 6-in. base rail.

AIR DISTRIBUTION COMPONENTS		AWL (in.)	Weight (lb)	DAMPER QUANTITY		
	Mixing Box	33	291	1		
	Side Inlet Mixing Box	27	391	2		
	Filter Mixing Box (2-in. or 4-in. Flat Filter)	40	539	1		
	Filter Mixing Box (6-in. Flat Filter)	42	556	1		
	Filter Mixing Box (Angle Filter)	41	547	1		
	Filter Mixing Box (Bag Cartridge Filter)	53	645	1		
	Air Mixer	30	390	N/A		
	Exhaust Box	33	328	1		
	Side Outlet Exhaust Box	27	404	2		
	Combination Exhaust/Mixing Box	27	321	2		
	Internal Face and Bypass Damper	18	232	2		
	External Face and Bypass Damper Section	33	576	2		
	Multizone Damper (Front Discharge) (Two Deck)			Future offering		
	Multizone Damper (Top Discharge) (Two Deck)			Future offering		
FILTRATION COMPONENTS		AWL (in.)	Weight (lb)	FILTER QUANTITY	FILTER SIZE (in.)	FILTER AREA (ft <sup>2</sup> )
	2-in. or 4-in. Flat Filter	12	385	6	20 x 25	20.8
	2-in. Pre-Filter with 4-in. Flat Filter	14	395	6	20 x 25	20.8
	2-in. or 4-in. Angle Filter	26	447	8	20 x 25	27.8
	Short Bag/Side Loading Cartridge Filter	24	455	4 / 1	24 x 24 / 12 x 24	18.0
	Long Bag/Side Loading Cartridge Filter	42	548	4 / 1	24 x 24 / 12 x 24	18.0
	Bag/Front Loading Cartridge Filter	48	580	4 / 1	24 x 24 / 12 x 24	18.0
	Blow-thru Front Loading HEPA Filter	48	580	4 / 1	24 x 24 / 12 x 24	18.0
HEAT TRANSFER SECTIONS		MIN AWL (in.)	MIN Weight (lb)	MAX AWL (in.)	MAX Weight (lb)	
	Coil and Variable Length Plenum (with Drain Pan)	24	263	61	489	
	Coil and Variable Length Plenum (without Drain Pan)	12	201	60	465	
	Dual Coil and Variable Length Plenum (with Drain Pan)	24	263	61	489	
	Vertical Coil			Future offering		
	Multizone Front Discharge			Future offering		
	Multizone Top Discharge			Future offering		
	Internal Face and Bypass Cooling Coil	24	263	N/A	N/A	
	Internal Face and Bypass Heating Coil	12	201	24	263	
	Integral Face and Bypass Heating Coil			Future offering		
	Electric Heat with Control Box (Low Amp [min]/High Amp [max])	30	456	42	485	
	Gas Heat (Low BTU [min]/High BTU [max])			Future offering		
AIR MOVEMENT SECTIONS**		MIN AWL (in.)*	MIN Weight (lb)*	MAX AWL (in.)†	MAX Weight (lb)†	
	Airfoil Fan	61	1204	64	1222	
	Downblast Airfoil Fan	64	1214	67	1334	
	Forward Curved Fan	49	1232	57	1244	
	Belt-Drive Plenum Fan			Future offering		
	Direct Drive Plenum Fan	49	853	57	1148	
	Fan Array			Future offering		
	Vertical Forward Curve Fan			Future offering		
	Vertical Airfoil Fan			Future offering		
MISCELLANEOUS SECTIONS		MIN AWL (in.)	MIN Weight (lb)	MAX AWL (in.)	MAX Weight (lb)	
	ERV Section			Future offering		
	Humidifier	24	453	48	576	
	Access and Plenum	12	453	48	392	
	Turning Plenum	24	333	N/A	N/A	

- LEGEND  
**AWL** — Airway Length  
**ERV** — Energy Recovery Ventilator  
**DA** — Duct Depth  
**DW** — Duct Width

\* Refer to **AHUBuilder®** program for application specific weight and AWL.  
 † Maximum is based on largest motor and largest fan wheel combination.  
 \*\* Minimum is based on smallest motor and smallest fan wheel combination.

→ **SIZE 21W (10,500 cfm)**

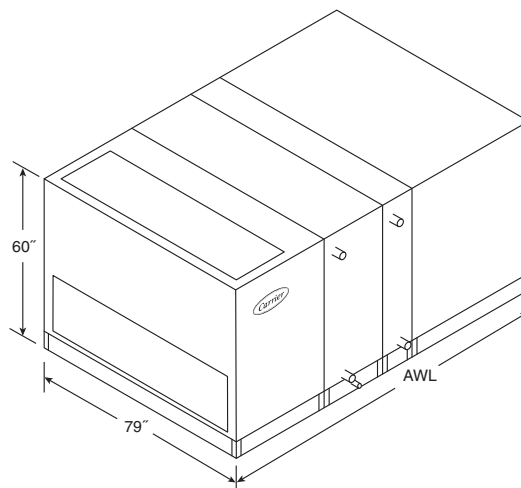

**NOTES:**

1. Dimensions are shown for indoor units. For outdoor units add 4 in. to height and 3 in. to width.
2. Height dimensions include 6-in. base rail.

AIR DISTRIBUTION COMPONENTS		AWL (in.)	Weight (lb)	DAMPER QUANTITY	
Mixing Box	27	301	2		
Side Inlet Mixing Box	39	388	2		
Filter Mixing Box (2-in. or 4-in. Flat Filter)	34	559	2		
Filter Mixing Box (6-in. Flat Filter)	36	575	2		
Filter Mixing Box (Angle Filter)	38	575	2		
Filter Mixing Box (Bag Cartridge Filter)	47	668	2		
Air Mixer	30	418	N/A		
Exhaust Box	27	335	2		
Side Outlet Exhaust Box	39	400	2		
Combination Exhaust Mixing Box	39	332	2		
Internal Face and Bypass Damper	18	233	2		
External Face and Bypass Damper Section	27	624	2		
Multizone Damper (Front Discharge) (Two Deck)	5	197	N/A		
Multizone Damper (Top Discharge) (Two Deck)	5 (height)	196	N/A		
FILTRATION COMPONENTS	AWL (in.)	Weight (lb)	FILTER QUANTITY	FILTER SIZE (in.)	FILTER AREA (ft <sup>2</sup> )
2-in. or 4-in. Flat Filter	12	406	6	20 x 25	20.8
2-in. Pre-Filter with 4-in. Flat Filter	14	417	6	20 x 25	20.8
2-in. or 4-in. Angle Filter	24	471	12	16 x 25	33.3
Short Bag/Side Loading Cartridge Filter	24	478	6	24 x 24	24.0
Long Bag/Side Loading Cartridge Filter	42	579	6	24 x 24	24.0
Bag/Front Loading Cartridge Filter	48	612	6	24 x 24	24.0
Blow-thru Front Loading HEPA Filter	48	612	6	24 x 24	24.0
HEAT TRANSFER SECTIONS	MIN AWL (in.)	MIN Weight (lb)	MAX AWL (in.)	MAX Weight (lb)	Zones
Coil and Variable Length Plenum (with Drain Pan)	24	266	61	498	
Coil and Variable Length Plenum (without Drain Pan)	12	199	60	481	
Dual Coil and Variable Length Plenum (with Drain Pan)	24	266	61	498	
Vertical Coil	48	425	N/A	N/A	
Multizone Front Discharge	73	1191	N/A	N/A	12 zones
Multizone Top Discharge	73	1087	N/A	N/A	12 zones
Internal Face and Bypass Cooling Coil	24	266	N/A	N/A	
Internal Face and Bypass Heating Coil	12	199	24	266	
Integral Face and Bypass Heating Coil	48	406	N/A	N/A	
Electric Heat with Control Box (Low Amp [min]/High Amp [max])	30	485	30	485	
Gas Heat (Low BTU [min]/High BTU [max])	91	1235	127	1904	
AIR MOVEMENT SECTIONS**	MIN AWL (in.)*	MIN Weight (lb)*	MAX AWL (in.)†	MAX Weight (lb)†	
Airfoil Fan	46	1277	48	1472	
Downblast Airfoil Fan	49	1402	51	1489	
Forward Curved Fan	48	1365	48	1395	
Belt-Drive Plenum Fan	48	1339	54	1577	
Direct Drive Plenum Fan	51	1014	61	1391	
Fan Array	42	881	46	1279	
Vertical Forward Curve Fan	48	1474	48	1474	
Vertical Airfoil Fan	48	1346	48	1550	
MISCELLANEOUS SECTIONS	MIN AWL (in.)	MIN Weight (lb)	MAX AWL (in.)	MAX Weight (lb)	
ERV Section	121	3871	147	4411	
Humidifier	24	476	48	609	
Access and Plenum	12	205	48	405	
Turning Plenum	30	351	N/A	N/A	

**LEGEND**

- AWL — Airway Length
- ERV — Energy Recovery Ventilator
- DA — Duct Depth
- DW — Duct Width

\* Refer to **AHUBuilder®** program for application specific weight and AWL.  
 † Maximum is based on largest motor and largest fan wheel combination.  
 \*\* Minimum is based on smallest motor and smallest fan wheel combination.

# Dimensions (cont)



→ **SIZE 22T (11,000 cfm)**

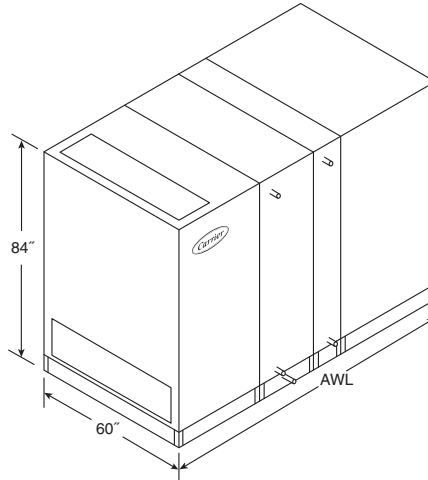

**NOTES:**

1. Dimensions are shown for indoor units. For outdoor units add 4 in. to height and 3 in. to width.
2. Height dimensions include 6-in. base rail.

AIR DISTRIBUTION COMPONENTS		AWL (in.)	Weight (lb)	DAMPER QUANTITY		
Mixing Box		39	327			2
Side Inlet Mixing Box		33	437			2
Filter Mixing Box (2-in. or 4-in. Flat Filter)		46	607			2
Filter Mixing Box (6-in. Flat Filter)		48	624			2
Filter Mixing Box (Angle Filter)		48	624			2
Filter Mixing Box (Bag Cartridge Filter)		59	721			2
Air Mixer		30	444			N/A
Exhaust Box		39	370			2
Side Outlet Exhaust Box		33	450			2
Combination Exhaust Mixing Box		33	360			2
Internal Face and Bypass Damper		18	247			2
External Face and Bypass Damper Section		39	664			2
Multizone Damper (Front Discharge) (Two Deck)					Future offering	
Multizone Damper (Top Discharge) (Two Deck)					Future offering	
FILTRATION COMPONENTS		AWL (in.)	Weight (lb)	FILTER QUANTITY	FILTER SIZE (in.)	FILTER AREA (ft <sup>2</sup> )
2-in. or 4-in. Flat Filter		12	425	2 / 6	20 x 25 / 16 x 25	23.6
2-in. Pre-Filter with 4-in. Flat Filter		14	436	2 / 6	20 x 25 / 16 x 25	23.6
2-in. or 4-in. Angle Filter		23	493	12	16 x 25	33.3
Short Bag/Side Loading Cartridge Filter		24	500	6	24 x 24	24.0
Long Bag/Side Loading Cartridge Filter		42	599	6	24 x 24	24.0
Bag/Front Loading Cartridge Filter		48	633	6	24 x 24	24.0
Blow-thru Front Loading HEPA Filter		48	633	4 / 2	24 x 24 / 12 x 24	20.0
HEAT TRANSFER SECTIONS		MIN AWL (in.)	MIN Weight (lb)	MAX AWL (in.)	MAX Weight (lb)	
Coil and Variable Length Plenum (with Drain Pan)		24	280	61	522	
Coil and Variable Length Plenum (without Drain Pan)		12	213	60	495	
Dual Coil and Variable Length Plenum (with Drain Pan)		24	280	61	522	
Vertical Coil					Future offering	
Multizone Front Discharge					Future offering	
Multizone Top Discharge					Future offering	
Internal Face and Bypass Cooling Coil		24	280	N/A	N/A	
Internal Face and Bypass Heating Coil		12	213	24	279	
Integral Face and Bypass Heating Coil					Future offering	
Electric Heat with Control Box (Low Amp [min]/High Amp [max])		30	506	42	532	
Gas Heat (Low BTU [min]/High BTU [max])					Future offering	
AIR MOVEMENT SECTIONS**		MIN AWL (in.)*	MIN Weight (lb)*	MAX AWL (in.)†	MAX Weight (lb)†	
Airfoil Fan		64	1362	66	1385	
Downblast Airfoil Fan		67	1368	72	1494	
Forward Curved Fan		49	1387	64	1405	
Belt-Drive Plenum Fan					Future offering	
Direct Drive Plenum Fan		51	995	61	1308	
Fan Array					Future offering	
Vertical Forward Curve Fan					Future offering	
Vertical Airfoil Fan					Future offering	
MISCELLANEOUS SECTIONS		MIN AWL (in.)	MIN Weight (lb)	MAX AWL (in.)	MAX Weight (lb)	
ERV Section					Future offering	
Humidifier		24	502	48	636	
Access and Plenum		12	502	48	419	
Turning Plenum		30	366	N/A	N/A	

**LEGEND**  
**AWL** — Airway Length  
**ERV** — Energy Recovery Ventilator  
**DA** — Duct Depth  
**DW** — Duct Width

\*Refer to **AHUBuilder®** program for application specific weight and AWL.  
 † Maximum is based on largest motor and largest fan wheel combination.  
 \*\* Minimum is based on smallest motor and smallest fan wheel combination.

→ **SIZE 25W (12,500 cfm)**

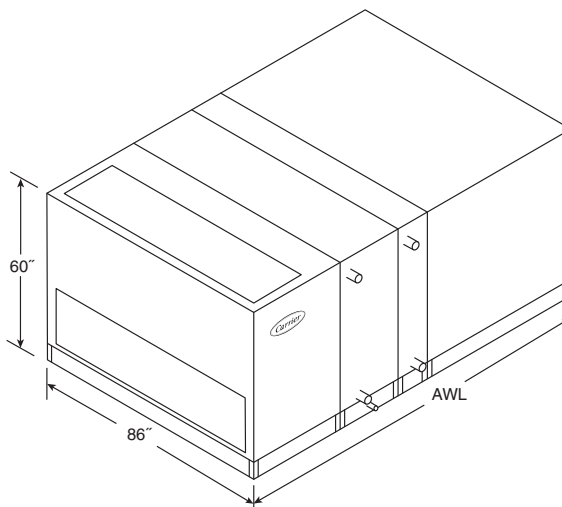

**NOTES:**

1. Dimensions are shown for indoor units. For outdoor units add 4 in. to height and 3 in. to width.
2. Height dimensions include 6-in. base rail.

AIR DISTRIBUTION COMPONENTS		AWL (in.)	Weight (lb)	DAMPER QUANTITY		
	Mixing Box	27	315	2		
	Side Inlet Mixing Box	45	439	2		
	Filter Mixing Box (2-in. or 4-in. Flat Filter)	34	605	2		
	Filter Mixing Box (6-in. Flat Filter)	36	622	2		
	Filter Mixing Box (Angle Filter)	36	622	2		
	Filter Mixing Box (Bag Cartridge Filter)	47	719	2		
	Air Mixer	30	445	N/A		
	Exhaust Box	27	357	2		
	Side Outlet Exhaust Box	45	457	2		
	Combination Exhaust Mixing Box	45	347	2		
	Internal Face and Bypass Damper	18	243	2		
	External Face and Bypass Damper Section	27	697	2		
	Multizone Damper (Front Discharge) (Two Deck)	5	224	N/A		
	Multizone Damper (Top Discharge) (Two Deck)	5 (height)	224	N/A		
FILTRATION COMPONENTS		AWL (in.)	Weight (lb)	FILTER QUANTITY	FILTER SIZE (in.)	FILTER AREA (ft <sup>2</sup> )
	2-in. or 4-in. Flat Filter	12	444	8	24 x 20	26.7
	2-in. Pre-Filter with 4-in. Flat Filter	14	456	8	24 x 20	26.7
	2-in. or 4-in. Angle Filter	24	514	12	16 x 25	33.3
	Short Bag/Side Loading Cartridge Filter	24	520	6	24 x 24	24.0
	Long Bag/Side Loading Cartridge Filter	42	625	6	24 x 24	24.0
	Bag/Front Loading Cartridge Filter	48	660	6	24 x 24	24.0
	Blow-thru Front Loading HEPA Filter	48	660	6	24 x 24	24.0
HEAT TRANSFER SECTIONS		MIN AWL (in.)	MIN Weight (lb)	MAX AWL (in.)	MAX Weight (lb)	Zones
	Coil and Variable Length Plenum (with Drain Pan)	24	278	61	521	
	Coil and Variable Length Plenum (without Drain Pan)	12	208	60	502	
	Dual Coil and Variable Length Plenum (with Drain Pan)	24	278	61	521	
	Vertical Coil	60	520	N/A	N/A	
	Multizone Front Discharge	73	1252	N/A	N/A	13 zones
	Multizone Top Discharge	73	1137	N/A	N/A	13 zones
	Internal Face and Bypass Cooling Coil	24	278	N/A	N/A	
	Internal Face and Bypass Heating Coil	12	208	24	278	
	Integral Face and Bypass Heating Coil	48	424	N/A	N/A	
	Electric Heat with Control Box (Low Amp [min]/High Amp [max])	30	528	30	528	
	Gas Heat (Low BTU [min]/High BTU [max])	91	1282	127	1965	
AIR MOVEMENT SECTIONS**		MIN AWL (in.)*	MIN Weight (lb)*	MAX AWL (in.)†	MAX Weight (lb)†	
	Airfoil Fan	46	1460	58	1677	
	Downblast Airfoil Fan	49	1508	61	1712	
	Forward Curved Fan	60	1586	60	1586	
	Belt-Drive Plenum Fan	54	1486	54	1689	
	Direct Drive Plenum Fan	54	1123	65	1632	
	Fan Array	44	951	50	1424	
	Vertical Forward Curve Fan	60	1536	60	1664	
	Vertical Airfoil Fan	60	1538	60	1781	
MISCELLANEOUS SECTIONS		MIN AWL (in.)	MIN Weight (lb)	MAX AWL (in.)	MAX Weight (lb)	
	ERV Section	138	4483	170	5113	
	Humidifier	24	512	48	652	
	Access and Plenum	12	214	48	423	
	Turning Plenum	30	369	N/A	N/A	

**LEGEND**

- AWL — Airway Length
- ERV — Energy Recovery Ventilator
- DA — Duct Depth
- DW — Duct Width

\* Refer to **AHUBuilder®** program for application specific weight and AWL.  
 † Maximum is based on largest motor and largest fan wheel combination.  
 \*\* Minimum is based on smallest motor and smallest fan wheel combination.

# Dimensions (cont)



→ **SIZE 25T (12,500 cfm)**

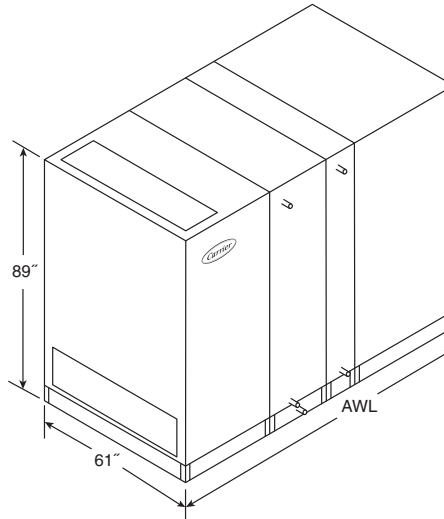

**NOTES:**

1. Dimensions are shown for indoor units. For outdoor units add 4 in. to height and 3 in. to width.
2. Height dimensions include 6-in. base rail.

AIR DISTRIBUTION COMPONENTS		AWL (in.)	Weight (lb)	DAMPER QUANTITY		
	Mixing Box	45	354	2		
	Side Inlet Mixing Box	33	473	3		
	Filter Mixing Box (2-in. or 4-in. Flat Filter)	52	672	2		
	Filter Mixing Box (6-in. Flat Filter)	54	691	2		
	Filter Mixing Box (Angle Filter)	53	681	2		
	Filter Mixing Box (Bag Cartridge Filter)	65	791	2		
	Air Mixer	30	485	N/A		
	Exhaust Box	45	400	2		
	Side Outlet Exhaust Box	33	484	3		
	Combination Exhaust Mixing Box	33	390	3		
	Internal Face and Bypass Damper	18	258	2		
	External Face and Bypass Damper Section	45	731	2		
	Multizone Damper (Front Discharge) (Two Deck)			Future offering		
	Multizone Damper (Top Discharge) (Two Deck)			Future offering		
FILTRATION COMPONENTS		AWL (in.)	Weight (lb)	FILTER QUANTITY	FILTER SIZE (in.)	FILTER AREA (ft <sup>2</sup> )
	2-in. or 4-in. Flat Filter	12	456	2 / 6	16 x 25 / 20 x 25	26.4
	2-in. Pre-Filter with 4-in. Flat Filter	14	467	2 / 6	16 x 25 / 20 x 25	26.4
	2-in. or 4-in. Angle Filter	30	527	12	25 x 16	33.3
	Short Bag/Side Loading Cartridge Filter	24	534	6	24 x 24	24.0
	Long Bag/Side Loading Cartridge Filter	42	638	6	24 x 24	24.0
	Bag/Front Loading Cartridge Filter	48	673	6	24 x 24	24.0
	Blow-thru Front Loading HEPA Filter	48	673	6	24 x 24	24.0
HEAT TRANSFER SECTIONS		MIN AWL (in.)	MIN Weight (lb)	MAX AWL (in.)	MAX Weight (lb)	
	Coil and Variable Length Plenum (with Drain Pan)	24	293	61	547	
	Coil and Variable Length Plenum (without Drain Pan)	12	223	60	518	
	Dual Coil and Variable Length Plenum (with Drain Pan)	24	293	61	547	
	Vertical Coil				Future offering	
	Multizone Front Discharge				Future offering	
	Multizone Top Discharge				Future offering	
	Internal Face and Bypass Cooling Coil	24	293	N/A	N/A	
	Internal Face and Bypass Heating Coil	12	223	24	292	
	Integral Face and Bypass Heating Coil				Future offering	
	Electric Heat with Control Box (Low Amp [min]/High Amp [max])	30	543	42	568	
	Gas Heat (Low BTU [min]/High BTU [max])				Future offering	
AIR MOVEMENT SECTIONS**		MIN AWL (in.)*	MIN Weight (lb)*	MAX AWL (in.)†	MAX Weight (lb)†	
	Airfoil Fan	66	1408	68	1506	
	Downblast Airfoil Fan	72	1483	74	1615	
	Forward Curved Fan	58	1504	64	1526	
	Belt-Drive Plenum Fan				Future offering	
	Direct Drive Plenum Fan	54	1101	65	1429	
	Fan Array				Future offering	
	Vertical Forward Curve Fan				Future offering	
	Vertical Airfoil Fan				Future offering	
MISCELLANEOUS SECTIONS		MIN AWL (in.)	MIN Weight (lb)	MAX AWL (in.)	MAX Weight (lb)	
	ERV Section				Future offering	
	Humidifier	24	539	48	681	
	Access and Plenum	12	539	48	439	
	Turning Plenum	30	391	N/A	N/A	

**LEGEND**

- AWL** — Airway Length
- ERV** — Energy Recovery Ventilator
- DA** — Duct Depth
- DW** — Duct Width

\* Refer to **AHUBuilder®** program for application specific weight and AWL.

† Maximum is based on largest motor and largest fan wheel combination.

\*\* Minimum is based on smallest motor and smallest fan wheel combination.



→ **SIZE 30W (15,000 cfm)**

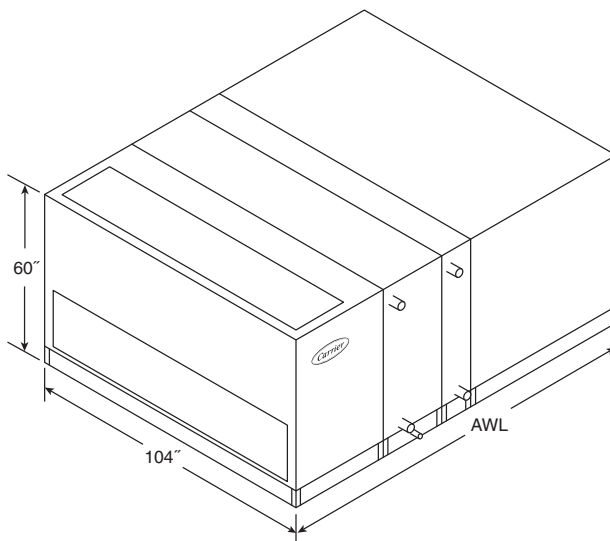

**NOTES:**

1. Dimensions are shown for indoor units. For outdoor units add 4 in. to height and 3 in. to width.
2. Height dimensions include 6-in. base rail.

AIR DISTRIBUTION COMPONENTS		AWL (in.)	Weight (lb)	DAMPER QUANTITY		
Mixing Box		27	409	2		
Side Inlet Mixing Box		51	601	2		
Filter Mixing Box (2-in. or 4-in. Flat Filter)		34	744	2		
Filter Mixing Box (6-in. Flat Filter)		36	766	2		
Filter Mixing Box (Angle Filter)		36	766	2		
Filter Mixing Box (Bag Cartridge Filter)		47	890	2		
Air Mixer		36	606	N/A		
Exhaust Box		27	455	2		
Side Outlet Exhaust Box		51	618	2		
Combination Exhaust Mixing Box		51	450	2		
Internal Face and Bypass Damper		18	323	2		
External Face and Bypass Damper Section		27	858	2		
Multizone Damper (Front Discharge) (Two Deck)		5	260	N/A		
Multizone Damper (Top Discharge) (Two Deck)		5 (height)	260	N/A		
FILTRATION COMPONENTS		AWL (in.)	Weight (lb)	FILTER QUANTITY	FILTER SIZE (in.)	FILTER AREA (ft <sup>2</sup> )
2-in. or 4-in. Flat Filter		12	555	10	24 x 20	33.3
2-in. Pre-Filter with 4-in. Flat Filter		14	568	10	24 x 20	33.3
2-in. or 4-in. Angle Filter		24	638	16	16 x 25	44.4
Short Bag/Side Loading Cartridge Filter		24	645	8	24 x 24	32.0
Long Bag/Side Loading Cartridge Filter		42	770	8	24 x 24	32.0
Bag/Front Loading Cartridge Filter		48	811	8	24 x 24	32.0
Blow-thru Front Loading HEPA Filter		48	811	8	24 x 24	32.0
HEAT TRANSFER SECTIONS		MIN AWL (in.)	MIN Weight (lb)	MAX AWL (in.)	MAX Weight (lb)	Zones
Coil and Variable Length Plenum (with Drain Pan)		24	365	61	675	
Coil and Variable Length Plenum (without Drain Pan)		12	282	60	628	
Dual Coil and Variable Length Plenum (with Drain Pan)		24	365	61	675	
Vertical Coil		60	672	N/A	N/A	
Multizone Front Discharge		73	1528	N/A	N/A	16 zones
Multizone Top Discharge		73	1389	N/A	N/A	16 zones
Internal Face and Bypass Cooling Coil		24	365	N/A	N/A	
Internal Face and Bypass Heating Coil		12	282	24	364	
Integral Face and Bypass Heating Coil		48	537	N/A	N/A	
Electric Heat with Control Box (Low Amp [min]/High Amp [max])		30	661	30	661	
Gas Heat (Low BTU [min]/High BTU [max])		97	1440	163	3365	
AIR MOVEMENT SECTIONS**		MIN AWL (in.)*	MIN Weight (lb)*	MAX AWL (in.)†	MAX Weight (lb)†	
Airfoil Fan		58	1770	58	1923	
Downblast Airfoil Fan		61	1841	61	1864	
Forward Curved Fan		60	1799	60	1799	
Belt-Drive Plenum Fan		54	1739	54	1984	
Direct Drive Plenum Fan		54	1273	69	1844	
Fan Array		44	1180	50	1572	
Vertical Forward Curve Fan		60	1912	60	1942	
Vertical Airfoil Fan		60	1942	60	2065	
MISCELLANEOUS SECTIONS		MIN AWL (in.)	MIN Weight (lb)	MAX AWL (in.)	MAX Weight (lb)	
ERV Section		138	5388	179	6156	
Humidifier		24	630	48	796	
Access and Plenum		12	289	48	537	
Turning Plenum		30	473	N/A	N/A	

**LEGEND**

- AWL — Airway Length
- ERV — Energy Recovery Ventilator
- DA — Duct Depth
- DW — Duct Width

\* Refer to **AHUBuilder®** program for application specific weight and AWL.

† Maximum is based on largest motor and largest fan wheel combination.

\*\* Minimum is based on smallest motor and smallest fan wheel combination.

# Dimensions (cont)



→ **SIZE 30T (15,000 cfm)**

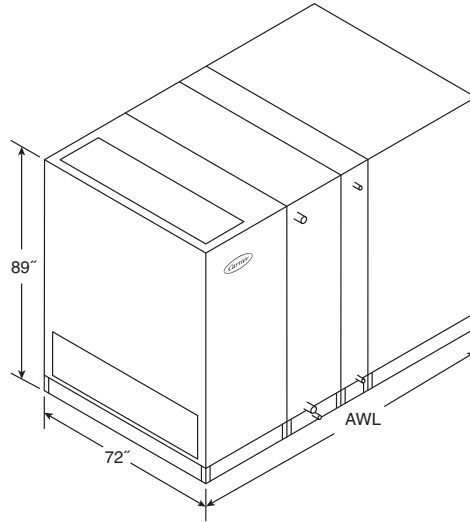

**NOTES:**

1. Dimensions are shown for indoor units. For outdoor units add 4 in. to height and 3 in. to width.
2. Height dimensions include 6-in. base rail.

AIR DISTRIBUTION COMPONENTS		AWL (in.)	Weight (lb)	DAMPER QUANTITY		
	Mixing Box	45	399	2		
	Side Inlet Mixing Box	39	531	3		
	Filter Mixing Box (2-in. or 4-in. Flat Filter)	52	767	2		
	Filter Mixing Box (6-in. Flat Filter)	54	786	2		
	Filter Mixing Box (Angle Filter)	53	776	2		
	Filter Mixing Box (Bag Cartridge Filter)	65	895	2		
	Air Mixer	36	553	N/A		
	Exhaust Box	45	452	2		
	Side Outlet Exhaust Box	39	542	3		
	Combination Exhaust Mixing Box	39	439	3		
	Internal Face and Bypass Damper	18	276	2		
	External Face and Bypass Damper Section	45	841	2		
	Multizone Damper (Front Discharge) (Two Deck)			Future offering		
	Multizone Damper (Top Discharge) (Two Deck)			Future offering		
FILTRATION COMPONENTS		AWL (in.)	Weight (lb)	FILTER QUANTITY	FILTER SIZE (in.)	FILTER AREA (ft <sup>2</sup> )
	2-in. or 4-in. Flat Filter	12	506	9	24 x 20	30.0
	2-in. Pre-Filter with 4-in. Flat Filter	14	519	9	24 x 20	30.0
	2-in. or 4-in. Angle Filter	30	584	16	25 x 16	44.4
	Short Bag/Side Loading Cartridge Filter	24	591	6 / 3	24 x 24 / 12 x 24	30.0
	Long Bag/Side Loading Cartridge Filter	42	702	6 / 3	24 x 24 / 12 x 24	30.0
	Bag/Front Loading Cartridge Filter	48	739	6 / 3	24 x 24 / 12 x 24	30.0
	Blow-thru Front Loading HEPA Filter	48	739	6 / 3	24 x 24 / 12 x 24	30.0
HEAT TRANSFER SECTIONS		MIN AWL (in.)	MIN Weight (lb)	MAX AWL (in.)	MAX Weight (lb)	
	Coil and Variable Length Plenum (with Drain Pan)	24	314	61	589	
	Coil and Variable Length Plenum (without Drain Pan)	12	239	60	555	
	Dual Coil and Variable Length Plenum (with Drain Pan)	24	314	61	589	
	Vertical Coil				Future offering	
	Multizone Front Discharge				Future offering	
	Multizone Top Discharge				Future offering	
	Internal Face and Bypass Cooling Coil	24	314	N/A	N/A	
	Internal Face and Bypass Heating Coil	12	239	24	313	
	Integral Face and Bypass Heating Coil				Future offering	
	Electric Heat with Control Box (Low Amp [min]/High Amp [max])	30	605	42	628	
	Gas Heat (Low BTU [min]/High BTU [max])				Future offering	
AIR MOVEMENT SECTIONS**		MIN AWL (in.)*	MIN Weight (lb)*	MAX AWL (in.)†	MAX Weight (lb)†	
	Airfoil Fan	66	1677	72	1710	
	Downblast Airfoil Fan	72	1676	77	1815	
	Forward Curved Fan	59	1698	59	1727	
	Belt-Drive Plenum Fan				Future offering	
	Direct Drive Plenum Fan	54	1278	65	1630	
	Fan Array				Future offering	
	Vertical Forward Curve Fan				Future offering	
	Vertical Airfoil Fan				Future offering	
MISCELLANEOUS SECTIONS		MIN AWL (in.)	MIN Weight (lb)	MAX AWL (in.)	MAX Weight (lb)	
	ERV Section				Future offering	
	Humidifier	24	601	48	756	
	Access and Plenum	12	601	48	473	
	Turning Plenum	N/A	432	N/A	N/A	

- LEGEND**
- AWL — Airway Length
  - ERV — Energy Recovery Ventilator
  - DA — Duct Depth
  - DW — Duct Width

\* Refer to **AHUBuilder®** program for application specific weight and AWL.  
 † Maximum is based on largest motor and largest fan wheel combination.  
 \*\* Minimum is based on smallest motor and smallest fan wheel combination.

→ **SIZE 35T (18,000 cfm)**

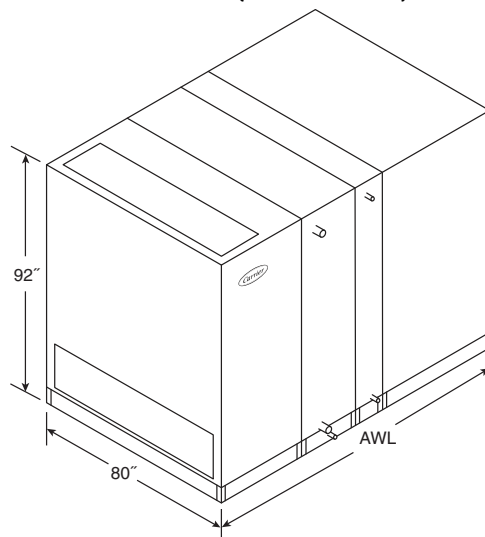

**NOTES:**

1. Dimensions are shown for indoor units. For outdoor units add 4 in. to height and 3 in. to width.
2. Height dimensions include 6-in. base rail.

<b>AIR DISTRIBUTION COMPONENTS</b>		<b>AWL (in.)</b>	<b>Weight (lb)</b>	<b>DAMPER QUANTITY</b>		
	Mixing Box	45	444	2		
	Side Inlet Mixing Box	39	590	3		
	Filter Mixing Box (2-in. or 4-in. Flat Filter)	52	862	2		
	Filter Mixing Box (6-in. Flat Filter)	54	883	2		
	Filter Mixing Box (Angle Filter)	53	872	2		
	Filter Mixing Box (Bag Cartridge Filter)	65	999	2		
	Air Mixer	36	621	N/A		
	Exhaust Box	45	503	2		
	Side Outlet Exhaust Box	45	600	3		
	Combination Exhaust Mixing Box	45	489	3		
	Internal Face and Bypass Damper	18	295	2		
	External Face and Bypass Damper Section	45	951	2		
	Multizone Damper (Front Discharge) (Two Deck)			Future offering		
	Multizone Damper (Top Discharge) (Two Deck)			Future offering		
<b>FILTRATION COMPONENTS</b>		<b>AWL (in.)</b>	<b>Weight (lb)</b>	<b>FILTER QUANTITY</b>	<b>FILTER SIZE (in.)</b>	<b>FILTER AREA (ft<sup>2</sup>)</b>
	2-in. or 4-in. Flat Filter	12	557	3 / 9	16 x 25 x 20 x 25	39.6
	2-in. Pre-Filter with 4-in. Flat Filter	14	570	3 / 9	16 x 25 x 20 x 25	39.6
	2-in. or 4-in. Angle Filter	23	640	18	16 x 25	50.0
	Short Bag/Side Loading Cartridge Filter	24	648	9	24 x 24	36.0
	Long Bag/Side Loading Cartridge Filter	42	765	9	24 x 24	36.0
	Bag/Front Loading Cartridge Filter	48	805	9	24 x 24	36.0
	Blow-thru Front Loading HEPA Filter	48	805	9	24 x 24	36.0
<b>HEAT TRANSFER SECTIONS</b>		<b>MIN AWL (in.)</b>	<b>MIN Weight (lb)</b>	<b>MAX AWL (in.)</b>	<b>MAX Weight (lb)</b>	
	Coil and Variable Length Plenum (with Drain Pan)	24	336	61	630	
	Coil and Variable Length Plenum (without Drain Pan)	12	256	60	593	
	Dual Coil and Variable Length Plenum (with Drain Pan)	24	336	61	630	
	Vertical Coil				Future offering	
	Multizone Front Discharge				Future offering	
	Multizone Top Discharge				Future offering	
	Internal Face and Bypass Cooling Coil	24	336	N/A	N/A	
	Internal Face and Bypass Heating Coil	12	256	24	334	
	Integral Face and Bypass Heating Coil				Future offering	
	Electric Heat with Control Box (Low Amp [min]/High Amp [max])	30	667	42	687	
	Gas Heat (Low BTU [min]/High BTU [max])				Future offering	
<b>AIR MOVEMENT SECTIONS**</b>		<b>MIN AWL (in.)*</b>	<b>MIN Weight (lb)*</b>	<b>MAX AWL (in.)†</b>	<b>MAX Weight (lb)†</b>	
	Airfoil Fan	77	1875	79	1913	
	Downblast Airfoil Fan	84	1869	87	2016	
	Forward Curved Fan	59	1892	71	1927	
	Belt-Drive Plenum Fan				Future offering	
	Direct Drive Plenum Fan	61	1454	69	1830	
	Fan Array				Future offering	
	Vertical Forward Curve Fan				Future offering	
	Vertical Airfoil Fan				Future offering	
<b>MISCELLANEOUS SECTIONS</b>		<b>MIN AWL (in.)</b>	<b>MIN Weight (lb)</b>	<b>MAX AWL (in.)</b>	<b>MAX Weight (lb)</b>	
	ERV Section				Future offering	
	Humidifier	24	663	48	831	
	Access and Plenum	12	663	48	507	
	Turning Plenum	33	473	N/A	N/A	

**LEGEND**

- AWL** — Airway Length
- ERV** — Energy Recovery Ventilator
- DA** — Duct Depth
- DW** — Duct Width

\* Refer to **AHUBuilder®** program for application specific weight and AWL.  
 † Maximum is based on largest motor and largest fan wheel combination.  
 \*\* Minimum is based on smallest motor and smallest fan wheel combination.

# Dimensions (cont)



→ **SIZE 36W (18000 cfm)**

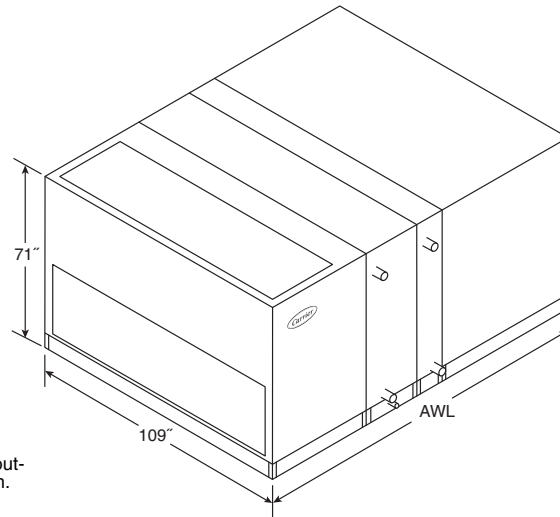

**NOTES:**

1. Dimensions are shown for indoor units. For outdoor units add 4 in. to height and 3 in. to width.
2. Height dimensions include 6-in. base rail.

AIR DISTRIBUTION COMPONENTS		AWL (in.)	Weight (lb)	DAMPER QUANTITY		
	Mixing Box	36	503	3		
	Side Inlet Mixing Box	57	717	2		
	Filter Mixing Box (2-in. or 4-in. Flat Filter)	43	878	3		
	Filter Mixing Box (6-in. Flat Filter)	45	903	3		
	Filter Mixing Box (Angle Filter)	45	903	3		
	Filter Mixing Box (Bag Cartridge Filter)	65	1153	3		
	Air Mixer	36	666	N/A		
	Exhaust Box	36	570	3		
	Side Outlet Exhaust Box	57	728	2		
	Combination Exhaust Mixing Box	39	554	2		
	Internal Face and Bypass Damper	18	357	3		
	External Face and Bypass Damper Section	33	1022	3		
	Multizone Damper (Front Discharge) (Two Deck)	5	302	N/A		
	Multizone Damper (Top Discharge) (Two Deck)	5 (height)	303	N/A		
FILTRATION COMPONENTS		AWL (in.)	Weight (lb)	FILTER QUANTITY	FILTER SIZE (in.)	FILTER AREA (ft <sup>2</sup> )
	2-in. or 4-in. Flat Filter	12	620	12	20 x 25	41.7
	2-in. Pre-Filter with 4-in. Flat Filter	14	635	12	20 x 25	41.7
	2-in. or 4-in. Angle Filter	26	725	16	20 x 25	55.5
	Short Bag/Side Loading Cartridge Filter	24	729	4 / 8	12 x 24 / 24 x 24	40.0
	Long Bag/Side Loading Cartridge Filter	42	864	4 / 8	12 x 24 / 24 x 24	40.0
	Bag/Front Loading Cartridge Filter	48	912	4 / 8	12 x 24 / 24 x 24	40.0
	Blow-thru Front Loading HEPA Filter	48	913	4 / 8	12 x 24 / 24 x 24	40.0
HEAT TRANSFER SECTIONS		MIN AWL (in.)	MIN Weight (lb)	MAX AWL (in.)	MAX Weight (lb)	Zones
	Coil and Variable Length Plenum (with Drain Pan)	24	402	61	753	
	Coil and Variable Length Plenum (without Drain Pan)	12	312	60	703	
	Dual Coil and Variable Length Plenum (with Drain Pan)	24	402	61	753	
	Vertical Coil	60	769	N/A	N/A	
	Multizone Front Discharge	85	1756	N/A	N/A	17 zones
	Multizone Top Discharge	85	1604	N/A	N/A	17 zones
	Internal Face and Bypass Cooling Coil	24	402	N/A	N/A	
	Internal Face and Bypass Heating Coil	12	312	24	401	
	Integral Face and Bypass Heating Coil	48	590	N/A	N/A	
	Electric Heat with Control Box (Low Amp [min]/High Amp [max])	30	762	30	762	
	Gas Heat (Low BTU [min]/High BTU [max])	100	2092	189	3133	
AIR MOVEMENT SECTIONS**		MIN AWL (in.)*	MIN Weight (lb)*	MAX AWL (in.)†	MAX Weight (lb)†	
	Airfoil Fan	57	1990	57	2017	
	Downblast Airfoil Fan	57	1988	61	2141	
	Forward Curved Fan	60	2044	60	2145	
	Belt-Drive Plenum Fan	54	2121	66	2343	
	Direct Drive Plenum Fan	61	1627	72	2161	
	Fan Array	47	1436	57	2005	
	Vertical Forward Curve Fan	60	2181	60	2253	
	Vertical Airfoil Fan	60	2179	60	2188	
MISCELLANEOUS SECTIONS		MIN AWL (in.)	MIN Weight (lb)	MAX AWL (in.)	MAX Weight (lb)	
	Humidifier	24	714	48	894	
	Access to Plenum	12	330	48	600	
	Turning Plenum	33	563	N/A	N/A	

**LEGEND**

- AWL — Airway Length
- ERV — Energy Recovery Ventilator
- DA — Duct Depth
- DW — Duct Width

\* Refer to **AHUBuilder®** program for application specific weight and AWL.

† Maximum is based on largest motor and largest fan wheel combination.

\*\* Minimum is based on smallest motor and smallest fan wheel combination.

→ **SIZE 37T (18,500 cfm)**

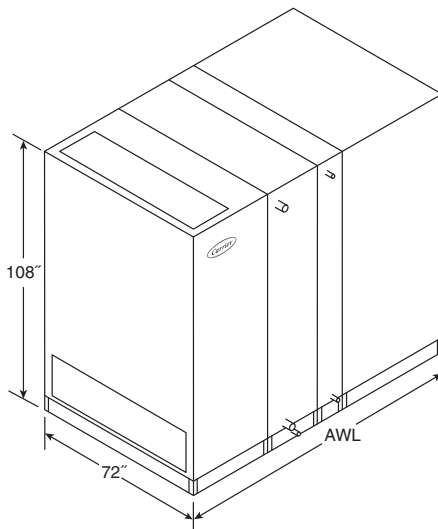

**NOTES:**

1. Dimensions are shown for indoor units. For outdoor units add 4 in. to height and 3 in. to width.
2. Height dimensions include 6-in. base rail.

AIR DISTRIBUTION COMPONENTS		AWL (in.)	Weight (lb)	DAMPER QUANTITY		
	Mixing Box	45	461	2		
	Side Inlet Mixing Box	39	613	3		
	Filter Mixing Box (2-in. or 4-in. Flat Filter)	52	932	2		
	Filter Mixing Box (6-in. Flat Filter)	54	954	2		
	Filter Mixing Box (Angle Filter)	50	910	2		
	Filter Mixing Box (Bag Cartridge Filter)	65	1073	2		
	Air Mixer	36	648	N/A		
	Exhaust Box	45	523	2		
	Side Outlet Exhaust Box	39	623	3		
	Combination Exhaust Mixing Box	39	508	3		
	Internal Face and Bypass Damper	18	302	2		
	External Face and Bypass Damper Section	45	995	2		
	Multizone Damper (Front Discharge) (Two Deck)			Future offering		
	Multizone Damper (Top Discharge) (Two Deck)			Future offering		
FILTRATION COMPONENTS		AWL (in.)	Weight (lb)	FILTER QUANTITY	FILTER SIZE (in.)	FILTER AREA (ft <sup>2</sup> )
	2-in. or 4-in. Flat Filter	12	577	9 / 3	24 x 20 / 20 x 20	38.3
	2-in. Pre-Filter with 4-in. Flat Filter	14	591	9 / 3	24 x 20 / 20 x 20	38.3
	2-in. or 4-in. Angle Filter	27	663	24	20 x 16	53.3
	Short Bag/Side Loading Cartridge Filter	24	671	6 / 5	24 x 24 / 12 x 24	34.0
	Long Bag/Side Loading Cartridge Filter	42	791	6 / 5	24 x 24 / 12 x 24	34.0
	Bag/Front Loading Cartridge Filter	48	831	8 / 4	24 x 24 / 12 x 24	40.0
	Blow-thru Front Loading HEPA Filter	48	831	6 / 5	24 x 24 / 12 x 24	34.0
HEAT TRANSFER SECTIONS		MIN AWL (in.)	MIN Weight (lb)	MAX AWL (in.)	MAX Weight (lb)	
	Coil and Variable Length Plenum (with Drain Pan)	24	344	61	647	
	Coil and Variable Length Plenum (without Drain Pan)	12	262	60	608	
	Dual Coil and Variable Length Plenum (with Drain Pan)	24	344	61	647	
	Vertical Coil				Future offering	
	Multizone Front Discharge				Future offering	
	Multizone Top Discharge				Future offering	
	Internal Face and Bypass Cooling Coil	24	344	N/A	N/A	
	Internal Face and Bypass Heating Coil	12	262	24	342	
	Integral Face and Bypass Heating Coil				Future offering	
	Electric Heat with Control Box (Low Amp [min]/High Amp [max])	30	692	42	711	
	Gas Heat (Low BTU [min]/High BTU [max])				Future offering	
AIR MOVEMENT SECTIONS**		MIN AWL (in.)*	MIN Weight (lb)*	MAX AWL (in.)†	MAX Weight (lb)†	
	Airfoil Fan	77	1954	79	1994	
	Downblast Airfoil Fan	84	1946	87	2096	
	Forward Curved Fan	59	1969	71	2008	
	Belt-Drive Plenum Fan				Future offering	
	Direct Drive Plenum Fan	62	1525	72	1911	
	Fan Array				Future offering	
	Vertical Forward Curve Fan				Future offering	
	Vertical Airfoil Fan				Future offering	
MISCELLANEOUS SECTIONS		MIN AWL (in.)	MIN Weight (lb)	MAX AWL (in.)	MAX Weight (lb)	
	ERV Section				Future offering	
	Humidifier	24	687	48	861	
	Access and Plenum	12	687	48	521	
	Turning Plenum	33	490	N/A	N/A	

**LEGEND**

- AWL — Airway Length
- ERV — Energy Recovery Ventilator
- DA — Duct Depth
- DW — Duct Width

\* Refer to **AHUBuilder®** program for application specific weight and AWL.  
 † Maximum is based on largest motor and largest fan wheel combination.  
 \*\* Minimum is based on smallest motor and smallest fan wheel combination.

# Dimensions (cont)



→ **SIZE 40W (20,000 cfm)**

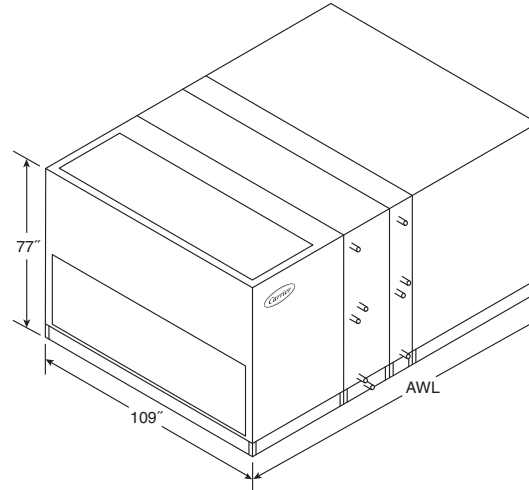

**NOTES:**

1. Dimensions are shown for indoor units. For outdoor units add 4 in. to height and 3 in. to width.
2. Height dimensions include 6-in. base rail.

AIR DISTRIBUTION COMPONENTS		AWL (in.)	Weight (lb)	DAMPER QUANTITY		
Mixing Box	39	538	3			
Side Inlet Mixing Box	57	741	2			
Filter Mixing Box (2-in. or 4-in. Flat Filter)	46	946	3			
Filter Mixing Box (6-in. Flat Filter)	48	971	3			
Filter Mixing Box (Angle Filter)	48	971	3			
Filter Mixing Box (Bag Cartridge Filter)	65	1190	3			
Air Mixer	42	741	N/A			
Exhaust Box	39	612	3			
Side Outlet Exhaust Box	57	752	2			
Combination Exhaust Mixing Box	39	592	2			
Internal Face and Bypass Damper	18	365	3			
External Face and Bypass Damper Section	33	1097	3			
Multizone Damper (Front Discharge) (Two Deck)	5	331	N/A			
Multizone Damper (Top Discharge) (Two Deck)	5 (height)	330	N/A			
FILTRATION COMPONENTS		AWL (in.)	Weight (lb)	FILTER QUANTITY	FILTER SIZE (in.)	FILTER AREA (ft <sup>2</sup> )
2-in. or 4-in. Flat Filter	12	657	13	20 x 25	45.1	
2-in. Pre-Filter with 4-in. Flat Filter	14	673	13	20 x 25	45.1	
2-in. or 4-in. Angle Filter	24	749	24	16 x 25	66.7	
Short Bag/Side Loading Cartridge Filter	24	770	4 / 8	12 x 24 / 24 x 24	40.0	
Long Bag/Side Loading Cartridge Filter	42	909	4 / 8	12 x 24 / 24 x 24	40.0	
Bag/Front Loading Cartridge Filter	48	958	4 / 8	12 x 24 / 24 x 24	40.0	
Blow-thru Front Loading HEPA Filter	48	959	4 / 8	12 x 24 / 24 x 24	40.0	
HEAT TRANSFER SECTIONS		MIN AWL (in.)	MIN Weight (lb)	MAX AWL (in.)	MAX Weight (lb)	Zones
Coil and Variable Length Plenum (with Drain Pan)	24	411	61	773		
Coil and Variable Length Plenum (without Drain Pan)	12	319	60	722		
Dual Coil and Variable Length Plenum (with Drain Pan)	24	411	61	773		
Vertical Coil	60	799	66	835		
Multizone Front Discharge	91	1923	N/A	N/A	17 zones	
Multizone Top Discharge	91	1751	N/A	N/A	17 zones	
Internal Face and Bypass Cooling Coil	24	411	N/A	N/A		
Internal Face and Bypass Heating Coil	12	319	24	411		
Integral Face and Bypass Heating Coil	48	605	N/A	N/A		
Electric Heat with Control Box (Low Amp [min]/High Amp [max])	30	803	30	803		
Gas Heat (Low BTU [min]/High BTU [max])	99	2147	166	4363		
AIR MOVEMENT SECTIONS**		MIN AWL (in.)*	MIN Weight (lb)*	MAX AWL (in.)†	MAX Weight (lb)†	
Airfoil Fan	63	2181	63	2207		
Downblast Airfoil Fan	63	2191	63	2408		
Forward Curved Fan	60	2154	60	2258		
Belt-Drive Plenum Fan	72	2428	72	2519		
Direct Drive Plenum Fan	62	1723	72	2208		
Fan Array	47	1474	57	2046		
Vertical Forward Curve Fan	50	2083	60	2376		
Vertical Airfoil Fan	66	2350	60	2362		
MISCELLANEOUS SECTIONS		MIN AWL (in.)	MIN Weight (lb)	MAX AWL (in.)	MAX Weight (lb)	
Humidifier	24	749	48	934		
Access and Plenum	12	338	48	616		
Turning Plenum	33	587	N/A	N/A		

**LEGEND**

- AWL — Airway Length
- ERV — Energy Recovery Ventilator
- DA — Duct Depth
- DW — Duct Width

\* Refer to **AHUBuilder®** program for application specific weight and AWL.

† Maximum is based on largest motor and largest fan wheel combination.

\*\* Minimum is based on smallest motor and smallest fan wheel combination.

→ **SIZE 50W (25,000 cfm)**

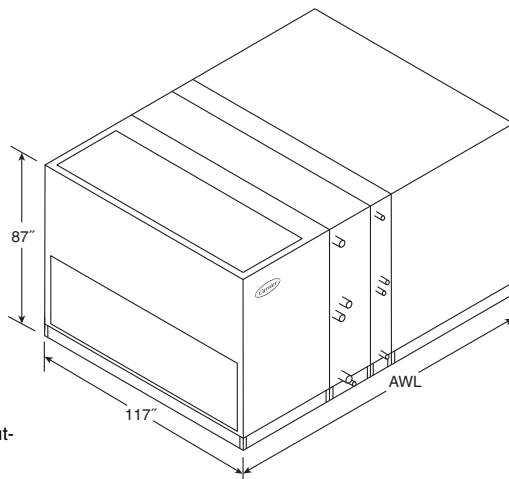

**NOTES:**

1. Dimensions are shown for indoor units. For outdoor units add 4 in. to height and 3 in. to width.
2. Height dimensions include 6-in. base rail.

AIR DISTRIBUTION COMPONENTS		AWL (in.)	Weight (lb)	DAMPER QUANTITY		
Mixing Box	42	616	3			
Side Inlet Mixing Box	63	913	2			
Filter Mixing Box (2-in. or 4-in. Flat Filter)	49	1105	3			
Filter Mixing Box (6-in. Flat Filter)	51	1132	3			
Filter Mixing Box (Angle Filter)	51	1132	3			
Filter Mixing Box (Bag Cartridge Filter)	62	1285	3			
Air Mixer	42	824	N/A			
Exhaust Box	42	700	3			
Side Outlet Exhaust Box	63	912	2			
Combination Exhaust Mixing Box	63	678	2			
Internal Face and Bypass Damper	18	394	3			
External Face and Bypass Damper Section	39	1327	3			
Multizone Damper (Front Discharge) (Two Deck)	5	402	N/A			
Multizone Damper (Top Discharge) (Two Deck)	5 (height)	401	N/A			
FILTRATION COMPONENTS		AWL (in.)	Weight (lb)	FILTER QUANTITY	FILTER SIZE (in.)	FILTER AREA (ft <sup>2</sup> )
2-in. or 4-in. Flat Filter	12	757	15	20 x 25	52.1	
2-in. Pre-Filter with 4-in. Flat Filter	14	774	15	20 x 25	52.1	
2-in. or 4-in. Angle Filter	24	856	18 / 12	16 x 20 / 16 x 25	73.3	
Short Bag/Side Loading Cartridge Filter	24	880	12 / 3	24 x 24 / 24 x 12	54.0	
Long Bag/Side Loading Cartridge Filter	42	1031	12 / 3	24 x 24 / 24 x 12	54.0	
Bag/Front Loading Cartridge Filter	48	1084	12 / 3	24 x 24 / 24 x 12	54.0	
Blow-thru Front Loading HEPA Filter	48	1085	12 / 3	24 x 24 / 24 x 12	54.0	
HEAT TRANSFER SECTIONS		MIN AWL (in.)	MIN Weight (lb)	MAX AWL (in.)	MAX Weight (lb)	Zones
Coil and Variable Length Plenum (with Drain Pan)	24	451	61	859		
Coil and Variable Length Plenum (without Drain Pan)	12	343	60	797		
Dual Coil and Variable Length Plenum (with Drain Pan)	24	451	61	859		
Vertical Coil	66	946	72	985		
Multizone Front Discharge	103	2316	N/A	N/A	18 zones	
Multizone Top Discharge	103	2069	N/A	N/A	18 zones	
Internal Face and Bypass Cooling Coil	24	451	N/A	N/A		
Internal Face and Bypass Heating Coil	12	343	24	444		
Integral Face and Bypass Heating Coil	48	655	N/A	N/A		
Electric Heat with Control Box (Low Amp [min]/High Amp [max])	30	916	30	916		
Gas Heat (Low BTU [min]/High BTU [max])	102	2395	192	3482		
AIR MOVEMENT SECTIONS**		MIN AWL (in.)*	MIN Weight (lb)*	MAX AWL (in.)†	MAX Weight (lb)†	
Airfoil Fan	69	2641	69	2531		
Downblast Airfoil Fan	69	2524	63	2864		
Forward Curved Fan	64	2598	64	2638		
Belt-Drive Plenum Fan	72	2717	72	2957		
Direct Drive Plenum Fan	67	2077	72	2359		
Fan Array	50	2748	61	2676		
Vertical Forward Curve Fan	66	2694	66	2819		
Vertical Airfoil Fan	72	2712	60	2747		
MISCELLANEOUS SECTIONS		MIN AWL (in.)	MIN Weight (lb)	MAX AWL (in.)	MAX Weight (lb)	
Humidifier	24	851	48	1060		
Access and Plenum	12	365	48	667		
Turning Plenum	36	686	N/A	N/A		

**LEGEND**

- AWL — Airway Length
- ERV — Energy Recovery Ventilator
- DA — Duct Depth
- DW — Duct Width

† Maximum is based on largest motor and largest fan wheel combination.  
 \*\* Minimum is based on smallest motor and smallest fan wheel combination.

\* Refer to **AHUBuilder®** program for application specific weight and AWL.

# Dimensions (cont)



→ **SIZE 61W (30,500 cfm)**

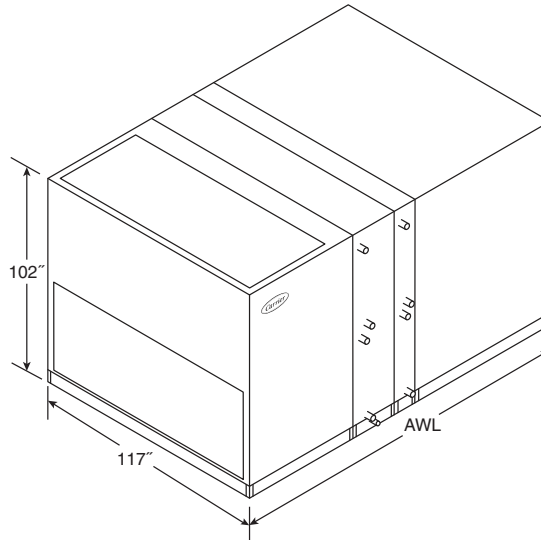

- NOTES:  
 1. Dimensions are shown for indoor units. For outdoor units add 4 in. to height and 3 in. to width.  
 2. Height dimensions include 6-in. base rail.

AIR DISTRIBUTION COMPONENTS	AWL (in.)	Weight (lb)	DAMPER QUANTITY		
Mixing Box	51	723	3		
Side Inlet Mixing Box	63	979	3		
Filter Mixing Box (2-in. or 4-in. Flat Filter)	58	1316	3		
Filter Mixing Box (6-in. Flat Filter)	60	1345	3		
Filter Mixing Box (Angle Filter)	60	1345	3		
Filter Mixing Box (Bag Cartridge Filter)	71	1507	3		
Air Mixer	48	951	N/A		
Exhaust Box	51	830	3		
Side Outlet Exhaust Box	63	978	3		
Combination Exhaust Mixing Box	63	796	3		
Internal Face and Bypass Damper	18	414	3		
External Face and Bypass Damper Section	45	1573	3		
Multizone Damper (Front Discharge) (Two Deck)	5	480	N/A		
Multizone Damper (Top Discharge) (Two Deck)	5 (height)	480	N/A		
FILTRATION COMPONENTS	AWL (in.)	Weight (lb)	FILTER QUANTITY	FILTER SIZE (in.)	FILTER AREA (ft <sup>2</sup> )
2-in. or 4-in. Flat Filter	12	858	14 / 14	20 x 16 / 25 x 16	70.0
2-in. Pre-Filter with 4-in. Flat Filter	14	875	14 / 14	20 x 16 / 25 x 16	70.0
2-in. or 4-in. Angle Filter	24	961	24 / 16	16 x 20 / 16 x 25	97.8
Short Bag/Side Loading Cartridge Filter	24	989	7 / 12	12 x 24 / 24 x 24	62.2
Long Bag/Side Loading Cartridge Filter	42	1151	7 / 12	12 x 24 / 24 x 24	62.2
Bag/Front Loading Cartridge Filter	48	1207	7 / 12	12 x 24 / 24 x 24	62.2
Blow-thru Front Loading HEPA Filter	48	1207	7 / 12	12 x 24 / 24 x 24	62.2
HEAT TRANSFER SECTIONS	MIN AWL (in.)	MIN Weight (lb)	MAX AWL (in.)	MAX Weight (lb)	Zones
Coil and Variable Length Plenum (with Drain Pan)	24	475	61	908	
Coil and Variable Length Plenum (without Drain Pan)	12	361	60	845	
Dual Coil and Variable Length Plenum (with Drain Pan)	24	475	61	908	
Vertical Coil	66	1030	78	1115	
Multizone Front Discharge	121	2725	N/A	N/A	18 zones
Multizone Top Discharge	121	2411	N/A	N/A	18 zones
Internal Face and Bypass Cooling Coil	24	475	N/A	N/A	
Internal Face and Bypass Heating Coil	12	361	24	468	
Integral Face and Bypass Heating Coil	48	695	N/A	N/A	
Electric Heat with Control Box (Low Amp [min]/High Amp [max])	30	1025	30	1025	
Gas Heat (Low BTU [min]/High BTU [max])	102	2506	169	5002	
AIR MOVEMENT SECTIONS**	MIN AWL (in.)*	MIN Weight (lb)*	MAX AWL (in.)†	MAX Weight (lb)†	
Airfoil Fan	69	2997	75	3238	
Downblast Airfoil Fan	69	2979	75	3226	
Forward Curved Fan	66	2811	66	2961	
Belt-Drive Plenum Fan	78	3112	78	3441	
Direct Drive Plenum Fan	68	2159	72	2481	
Fan Array	50	2869	65	3191	
Vertical Forward Curve Fan	66	3003	66	3153	
Vertical Airfoil Fan	78	3222	78	3452	
MISCELLANEOUS SECTIONS	MIN AWL (in.)	MIN Weight (lb)	MAX AWL (in.)	MAX Weight (lb)	
Humidifier	24	943	48	1166	
Access and Plenum	12	385	48	706	
Turning Plenum	36	751	N/A	N/A	

- LEGEND  
**AWL** — Airway Length  
**ERV** — Energy Recovery Ventilator  
**DA** — Duct Depth  
**DW** — Duct Width

\* Refer to **AHUBuilder®** program for application specific weight and AWL.  
 † Maximum is based on largest motor and largest fan wheel combination.  
 \*\* Minimum is based on smallest motor and smallest fan wheel combination.



→ **SIZE 72W (36,000 cfm)**

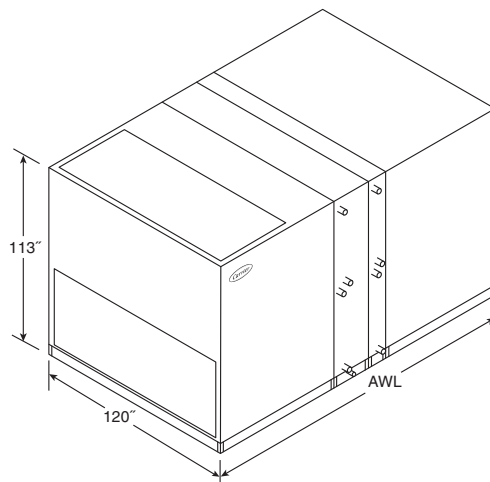

**NOTES:**

1. Dimensions are shown for indoor units. For outdoor units add 4 in. to height and 3 in. to width.
2. Height dimensions include 6-in. base rail.

AIR DISTRIBUTION COMPONENTS	AWL (in.)	Weight (lb)	DAMPER QUANTITY		
Mixing Box	53	795	3		
Side Inlet Mixing Box	57	953	3		
Filter Mixing Box (2-in. or 4-in. Flat Filter)	60	1381	3		
Filter Mixing Box (6-in. Flat Filter)	62	1412	3		
Filter Mixing Box (Angle Filter)	79	1675	3		
Filter Mixing Box (Bag Cartridge Filter)	73	1582	3		
Air Mixer	60	1195	N/A		
Exhaust Box	54	914	3		
Side Outlet Exhaust Box	57	954	3		
Combination Exhaust Mixing Box	57	875	3		
Internal Face and Bypass Damper	18	435	3		
External Face and Bypass Damper Section	54	1837	3		
FILTRATION COMPONENTS	AWL (in.)	Weight (lb)	FILTER QUANTITY	FILTER SIZE (in.)	FILTER AREA (ft <sup>2</sup> )
2-in. or 4-in. Flat Filter	12	959	33	20 x 16	73.3
2-in. Pre-Filter with 4-in. Flat Filter	14	978	33	20 x 16	73.3
2-in. or 4-in. Angle Filter	27	1098	56	16 x 20	124.4
Short Bag/Side Loading Cartridge Filter	24	1101	16 / 4	24 x 24 / 24 x 12	72.0
Long Bag/Side Loading Cartridge Filter	42	1272	16 / 4	24 x 24 / 24 x 12	72.0
Bag/Front Loading Cartridge Filter	48	1328	16 / 4	24 x 24 / 24 x 12	72.0
Blow-thru Front Loading HEPA Filter	48	1329	16 / 4	24 x 24 / 24 x 12	72.0
HEAT TRANSFER SECTIONS	MIN AWL (in.)	MIN Weight (lb)	MAX AWL (in.)	MAX Weight (lb)	
Coil and Variable Length Plenum (with Drain Pan)	24	499	61	966	
Coil and Variable Length Plenum (without Drain Pan)	12	378	60	890	
Dual Coil and Variable Length Plenum (with Drain Pan)	24	499	61	966	
Vertical Coil	N/A	N/A	N/A	N/A	
Multizone Front Discharge	N/A	N/A	N/A	N/A	
Multizone Top Discharge	N/A	N/A	N/A	N/A	
Internal Face and Bypass Cooling Coil	24	499	N/A	N/A	
Internal Face and Bypass Heating Coil	12	378	24	492	
Integral Face and Bypass Heating Coil	48	732	N/A	N/A	
Electric Heat with Control Box (Low Amp [min]/High Amp [max])	30	1133	30	1133	
Gas Heat (Low BTU [min]/High BTU [max])	100	2894	167	6132	
AIR MOVEMENT SECTIONS**	MIN AWL (in.)*	MIN Weight (lb)*	MAX AWL (in.)†	MAX Weight (lb)†	
Airfoil Fan	70	3320	76	3551	
Downblast Airfoil Fan	72	3307	79	3565	
Forward Curved Fan	70	3320	76	3563	
Belt-Drive Plenum Fan	67	3502	70	3725	
Direct Drive Plenum Fan	N/A	N/A	N/A	N/A	
Fan Array	51	3233	69	3372	
Vertical Forward Curve Fan	N/A	N/A	N/A	N/A	
Vertical Airfoil Fan	N/A	N/A	N/A	N/A	
MISCELLANEOUS SECTIONS	MIN AWL (in.)	MIN Weight (lb)	MAX AWL (in.)	MAX Weight (lb)	
Access and Plenum	12	405	48	744	
Turning Plenum	34	796	N/A	N/A	

**LEGEND**

- AWL — Airway Length
- ERV — Energy Recovery Ventilator
- DA — Duct Depth
- DW — Duct Width

\* Refer to **AHUBuilder®** program for application specific weight and AWL.  
 † Maximum is based on largest motor and largest fan wheel combination.  
 \*\* Minimum is based on smallest motor and smallest fan wheel combination.

# Dimensions (cont)



→ **SIZE 85W (42,500 cfm)**

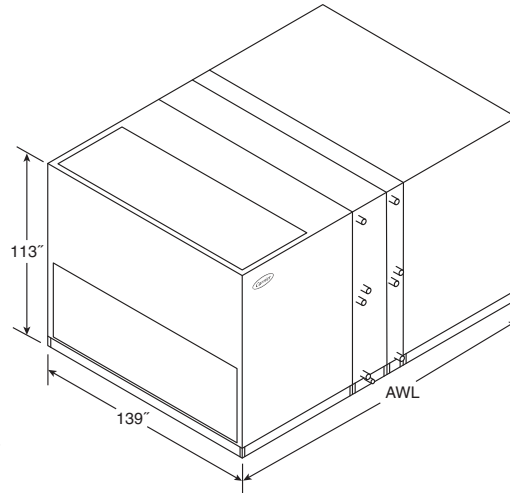

**NOTES:**

1. Dimensions are shown for indoor units. For outdoor units add 4 in. to height and 3 in. to width.
2. Height dimensions include 6-in. base rail.

AIR DISTRIBUTION COMPONENTS		AWL (in.)	Weight (lb)	DAMPER QUANTITY		
	Mixing Box	53	874	3		
	Side Inlet Mixing Box	65	1166	3		
	Filter Mixing Box (2-in. or 4-in. Flat Filter)	60	1539	3		
	Filter Mixing Box (6-in. Flat Filter)	62	1573	3		
	Filter Mixing Box (Angle Filter)	79	1861	3		
	Filter Mixing Box (Bag Cartridge Filter)	73	1760	3		
	Air Mixer	66	1371	N/A		
	Exhaust Box	53	1003	3		
	Side Outlet Exhaust Box	65	1169	3		
	Combination Exhaust Mixing Box	65	962	3		
	Internal Face and Bypass Damper	18	475	3		
	External Face and Bypass Damper Section	53	2092	3		
FILTRATION COMPONENTS		AWL (in.)	Weight (lb)	FILTER QUANTITY	FILTER SIZE (in.)	FILTER AREA (ft <sup>2</sup> )
	2-in. or 4-in. Flat Filter	12	1091	38	20 x 16	84.4
	2-in. Pre-Filter with 4-in. Flat Filter	14	1112	38	20 x 16	84.4
	2-in. or 4-in. Angle Filter	27	1246	64	16 x 20	142.2
	Short Bag/Side Loading Cartridge Filter	24	1245	20 / 4	24 x 24 / 24 x 12	88.0
	Long Bag/Side Loading Cartridge Filter	42	1434	20 / 4	24 x 24 / 24 x 12	88.0
	Bag/Front Loading Cartridge Filter	48	1496	20 / 4	24 x 24 / 24 x 12	88.0
	Blow-thru Front Loading HEPA Filter	48	1496	20	24 x 24	88.0
HEAT TRANSFER SECTIONS		MIN AWL (in.)	MIN Weight (lb)	MAX AWL (in.)	MAX Weight (lb)	
	Coil and Variable Length Plenum (with Drain Pan)	24	542	61	1031	
	Coil and Variable Length Plenum (without Drain Pan)	12	412	60	955	
	Dual Coil and Variable Length Plenum (with Drain Pan)	24	542	61	1031	
	Internal Face and Bypass Cooling Coil	24	542	N/A	N/A	
	Internal Face and Bypass Heating Coil	12	412	24	537	
	Integral Face and Bypass Heating Coil	48	801	N/A	N/A	
	Electric Heat with Control Box (Low Amp [min]/High Amp [max])	30	1281	30	1281	
	Gas Heat (Low BTU [min]/High BTU [max])	100	3166	167	6590	
AIR MOVEMENT SECTIONS**		MIN AWL (in.)*	MIN Weight (lb)*	MAX AWL (in.)†	MAX Weight (lb)†	
	Airfoil Fan	76	3844	81	3999	
	Downblast Airfoil Fan	79	3753	86	4022	
	Forward Curved Fan	76	3844	81	3999	
	Belt-Drive Plenum Fan	76	4015	79	4219	
	Fan Array	54	3985	72	3777	
MISCELLANEOUS SECTIONS		MIN AWL (in.)	MIN Weight (lb)	MAX AWL (in.)	MAX Weight (lb)	
	Access and Plenum	12	441	48	815	
	Turning Plenum	34	876	N/A	N/A	

**LEGEND**

- AWL — Airway Length
- ERV — Energy Recovery Ventilator
- DA — Duct Depth
- DW — Duct Width

\* Refer to **AHUBuilder®** program for application specific weight and AWL.  
 † Maximum is based on largest motor and largest fan wheel combination.  
 \*\* Minimum is based on smallest motor and smallest fan wheel combination.

→ **SIZE 96W (48,000 cfm)**

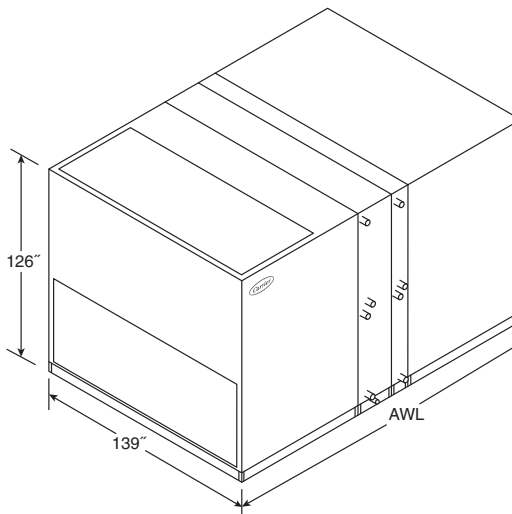

**NOTES:**

1. Dimensions are shown for indoor units. For outdoor units add 4 in. to height and 3 in. to width.
2. Height dimensions include 6-in. base rail.

AIR DISTRIBUTION COMPONENTS		AWL (in.)	Weight (lb)	DAMPER QUANTITY		
	Mixing Box	59	1025	3		
	Side Inlet Mixing Box	65	1229	3		
	Filter Mixing Box (2-in. or 4-in. Flat Filter)	66	1732	3		
	Filter Mixing Box (6-in. Flat Filter)	68	1767	3		
	Filter Mixing Box (Angle Filter)	84	2050	3		
	Filter Mixing Box (Bag Cartridge Filter)	79	1962	3		
	Air Mixer	69	1487	N/A		
	Exhaust Box	59	1160	3		
	Side Outlet Exhaust Box	65	1231	3		
	Combination Exhaust Mixing Box	65	113	3		
	Internal Face and Bypass Damper	18	493	3		
	External Face and Bypass Damper Section	59	2389	3		
FILTRATION COMPONENTS		AWL (in.)	Weight (lb)	FILTER QUANTITY	FILTER SIZE (in.)	FILTER AREA (ft <sup>2</sup> )
	2-in. or 4-in. Flat Filter	12	1189	24 / 12	20 x 16 x 20 x 25	95.0
	2-in. Pre-Filter with 4-in. Flat Filter	14	1211	24 / 12	20 x 16 x 20 x 25	95.0
	2-in. or 4-in. Angle Filter	27	1349	64	16 x 20	142.2
	Short Bag/Side Loading Cartridge Filter	24	1351	20 / 9	24 x 24 / 24 x 12	98.0
	Long Bag/Side Loading Cartridge Filter	42	1549	20 / 9	24 x 24 / 24 x 12	98.0
	Bag/Front Loading Cartridge Filter	48	1614	20 / 9	24 x 24 / 24 x 12	98.0
	Blow-thru Front Loading HEPA Filter	48	1614	20 / 5	24 x 24 / 24 x 12	98.0
HEAT TRANSFER SECTIONS		MIN AWL (in.)	MIN Weight (lb)	MAX AWL (in.)	MAX Weight (lb)	
	Coil and Variable Length Plenum (with Drain Pan)	24	562	61	1073	
	Coil and Variable Length Plenum (without Drain Pan)	12	427	60	997	
	Dual Coil and Variable Length Plenum (with Drain Pan)	24	562	61	1073	
	Internal Face and Bypass Cooling Coil	24	562	N/A	N/A	
	Internal Face and Bypass Heating Coil	12	427	24	558	
	Integral Face and Bypass Heating Coil	48	835	N/A	N/A	
	Electric Heat with Control Box (Low Amp [min]/High Amp [max])	30	1386	30	1386	
	Gas Heat (Low BTU [min]/High BTU [max])	104	3562	195	5667	
AIR MOVEMENT SECTIONS**		MIN AWL (in.)*	MIN Weight (lb)*	MAX AWL (in.)†	MAX Weight (lb)†	
	Airfoil Fan	76	4241	81	4308	
	Downblast Airfoil Fan	79	4153	86	4333	
	Forward Curved Fan	76	4241	81	4308	
	Belt-Drive Plenum Fan	79	4372	89	4675	
	Fan Array	54	4198	72	3897	
MISCELLANEOUS SECTIONS		MIN AWL (in.)	MIN Weight (lb)	MAX AWL (in.)	MAX Weight (lb)	
	Access and Plenum	12	458	48	849	
	Turning Plenum	38	971	N/A	N/A	

**LEGEND**

- AWL — Airway Length
- ERV — Energy Recovery Ventilator
- DA — Duct Depth
- DW — Duct Width

\* Refer to **AHUBuilder®** program for application specific weight and AWL.  
 † Maximum is based on largest motor and largest fan wheel combination.  
 \*\* Minimum is based on smallest motor and smallest fan wheel combination.

# Dimensions (cont)



→ **SIZE 110W (55,000 cfm)**

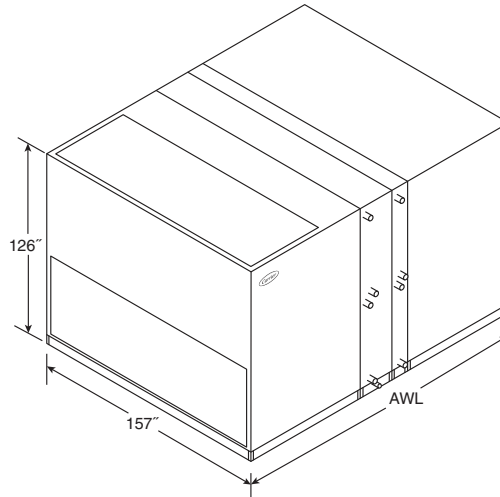

**NOTES:**

1. Dimensions are shown for indoor units. For outdoor units add 4 in. to height and 3 in. to width.
2. Height dimensions include 6-in. base rail.

AIR DISTRIBUTION COMPONENTS		AWL (in.)	Weight (lb)	DAMPER QUANTITY	
	Mixing Box	59	1025	4	
	Side Inlet Mixing Box	73	1410	4	
	Filter Mixing Box (2-in. or 4-in. Flat Filter)	66	1922	4	
	Filter Mixing Box (6-in. Flat Filter)	68	1957	4	
	Filter Mixing Box (Angle Filter)	84	2240	4	
	Filter Mixing Box (Bag Cartridge Filter)	79	2152	4	
	Air Mixer	69	1487	N/A	
	Exhaust Box	59	1160	4	
	Side Outlet Exhaust Box	73	1415	4	
	Combination Exhaust Mixing Box	73	113	4	
	Internal Face and Bypass Damper	18	527	4	
	External Face and Bypass Damper Section	59	2389	4	

FILTRATION COMPONENTS		AWL (in.)	Weight (lb)	FILTER QUANTITY	FILTER SIZE (in.)	FILTER AREA (ft <sup>2</sup> )
	2-in. or 4-in. Flat Filter	12	1189	27 / 14	20 x 16 / 20 x 25	108.6
	2-in. Pre-Filter with 4-in. Flat Filter	14	1211	27 / 14	20 x 16 / 20 x 25	108.6
	2-in. or 4-in. Angle Filter	27	1349	72	16 x 20	160.0
	Short Bag/Side Loading Cartridge Filter	24	1351	24 / 6	24 x 24 / 24 x 12	108.0
	Long Bag/Side Loading Cartridge Filter	42	1549	24 / 6	24 x 24 / 24 x 12	108.0
	Bag/Front Loading Cartridge Filter	48	1614	24 / 6	24 x 24 / 24 x 12	108.0
	Blow-thru Front Loading HEPA Filter	48	1614	24 / 6	24 x 24 / 24 x 12	108.0

HEAT TRANSFER SECTIONS		MIN AWL (in.)	MIN Weight (lb)	MAX AWL (in.)	MAX Weight (lb)
	Coil and Variable Length Plenum (with Drain Pan)	24	601	61	1143
	Coil and Variable Length Plenum (without Drain Pan)	12	458	60	1059
	Dual Coil and Variable Length Plenum (with Drain Pan)	24	601	61	1143
	Vertical Coil	N/A	N/A	N/A	N/A
	Internal Face and Bypass Cooling Coil	24	601	N/A	N/A
	Internal Face and Bypass Heating Coil	12	458	24	596
	Integral Face and Bypass Heating Coil	48	889	N/A	N/A
	Electric Heat with Control Box (Low Amp [min]/High Amp [max])	30	1530	30	1530
	Gas Heat (Low BTU [min]/High BTU [max])	104	3962	195	7669

AIR MOVEMENT SECTIONS**		MIN AWL (in.)*	MIN Weight (lb)*	MAX AWL (in.)†	MAX Weight (lb)†
	Airfoil Fan	72	4693	81	4703
	Downblast Airfoil Fan	86	4638	92	4794
	Forward Curved Fan	81	4703	81	4703
	Belt-Drive Plenum Fan	85	4890	95	5202
	Fan Array	54	4333	72	4044

MISCELLANEOUS SECTIONS		MIN AWL (in.)	MIN Weight (lb)	MAX AWL (in.)	MAX Weight (lb)
	Access and Plenum	12	458	48	849
	Turning Plenum	38	971	N/A	N/A

**LEGEND**

- AWL — Airway Length
- ERV — Energy Recovery Ventilator
- DA — Duct Depth
- DW — Duct Width

\* Refer to **AHUBuilder®** program for application specific weight and AWL.  
 † Maximum is based on largest motor and largest fan wheel combination.  
 \*\* Minimum is based on smallest motor and smallest fan wheel combination.

## AIR FRICTION DATA TYPICAL FILTER PRESSURE DROP (in. wg)

39M COMPONENT	FILTER TYPE	AIR VELOCITY THROUGH FILTER SECTION (fpm)											
		200	250	300	350	400	450	500	550	600	650	700	
FLAT	Throwaway (2 in.)	0.05	0.08	0.11	0.14	0.19	0.22	0.28	0.32	0.35	0.40	0.46	
	Permanent (2 in.)	0.03	0.04	0.05	0.07	0.09	0.11	0.13	0.15	0.17	0.19	0.21	
	Throwaway (4 in.)	0.06	0.09	0.12	0.15	0.19	0.22	0.28	0.32	0.35	0.40	0.46	
FILTER/MIXING BOX*	Throwaway (2 in.)	0.03	0.04	0.05	0.07	0.08	0.10	0.12	0.15	0.17	0.20	0.22	
	Permanent (2 in.)	0.02	0.03	0.04	0.05	0.06	0.08	0.09	0.10	0.12	0.14	0.15	
	Throwaway (4 in.)	0.04	0.05	0.06	0.08	0.08	0.10	0.12	0.15	0.17	0.20	0.22	
ANGLE*	Throwaway (2 in.)	0.01	0.02	0.03	0.05	0.05	0.06	0.07	0.08	0.11	0.12	0.14	
	Permanent (2 in.)	0.01	0.01	0.02	0.03	0.04	0.04	0.06	0.06	0.08	0.09	0.10	
	Throwaway (4 in.)	0.02	0.03	0.04	0.06	0.05	0.06	0.07	0.08	0.11	0.12	0.14	
BAG/ CARTRIDGE	Bag† (% Efficient)	(60-65)	0.07	0.10	0.13	0.17	0.21	0.25	0.30	0.36	0.40	0.48	0.52
		(80-85)	0.14	0.18	0.22	0.27	0.32	0.38	0.43	0.48	0.54	0.60	0.65
		(90-95)	0.23	0.29	0.36	0.43	0.51	0.60	0.67	0.75	0.85	0.94	1.00
	Cartridge** (% Efficient)	(60-65)	0.11	0.15	0.19	0.23	0.27	0.31	0.35	0.39	0.43	0.47	0.51
		(80-85)	0.20	0.25	0.30	0.35	0.40	0.45	0.50	0.55	0.60	0.65	0.71
		(90-95)	0.23	0.30	0.37	0.44	0.51	0.58	0.65	0.72	0.79	0.85	0.92
HEPA††		0.54	0.68	0.82	0.97	1.11	1.25	1.40	1.53	1.67	1.83	1.95	

\*Filter data shown is for clean filter. Consult filter manufacturer's recommendation for final dirty-filter pressure drop. Typically, 0.5 in. wg is allowed for dirty filter. Add pressure drop for pre-filter (flat filter) if used.

†Filter data shown is for clean filter. Consult filter manufacturer's recommendation for final dirty-filter pressure drop. Typically, 1.0 in. wg is allowed for dirty filter. Add pressure drop for pre-filter (flat filter) if used.

\*\*Filter data shown is for clean filter. Consult filter manufacturer's recommendation for final dirty-filter pressure drop. Typically, 1.5 in. wg is allowed for dirty filter. Add pressure drop for pre-filter (flat filter) if used.

††Filter data shown is for clean filter. Consult filter manufacturer's recommendation for final dirty-filter pressure drop. Typically, 2.5 in. wg is allowed for dirty filter. Add pressure drop for pre-filter (flat filter) if used.

NOTE: Filters are field-supplied and field-installed. Pressure drop values shown are typical and can vary with manufacturer and filter efficiency.

## COMPONENT PRESSURE DROP (in. wg)

39M COMPONENT	STANDARD DAMPERS OR COMPONENT CONSTRUCTION											
	Air Velocity Through Component (fpm)											
	400	600	800	1000	1200	1400	1600	1800	2000	3000	4000	
Air Mixer	—	0.07	0.11	0.15	0.21	0.29	0.39	—	—	—	—	—
Diffuser Plate	0.01	0.02	0.04	0.05	0.08	0.10	0.14	0.17	0.22	0.56	—	—
Electric Heat	0.01	0.02	0.04	0.05	0.08	0.10	0.14	—	—	—	—	—
Mixing or Exhaust Box	0.02	0.05	0.10	0.15	0.22	0.31	0.40	0.50	0.62	1.38	—	—
Zone Damper	—	—	—	0.03	0.04	0.06	0.07	0.09	0.10	0.25	0.48	—
Side Intake Louver	0.02	0.05	0.08	0.13	0.18	0.25	0.33	—	—	—	—	—
Rear Inlet Hood	0.24	0.53	0.94	1.47	—	—	—	—	—	—	—	—

39M COMPONENT	PREMIUM DAMPERS OR COMPONENT CONSTRUCTION											
	Air Velocity Through Dampers (fpm)											
	400	600	800	1000	1200	1400	1600	1800	2000	3000	4000	
Mixing or Exhaust Box	0.02	0.04	0.07	0.11	0.16	0.22	0.28	0.36	0.44	1.00	—	—
Side Mixing or Exhaust Box	0.02	0.04	0.07	0.11	0.16	0.22	0.28	0.36	0.44	1.00	—	—

### NOTES:

1. For mixing box dampers, worst case pressure drops will occur with one damper open and one closed. With one damper partially open and one partially closed, the actual pressure drop will be much less.

2. Diffuser plates are mounted on fan discharge.

## COOLING COIL AIR FRICTION (in. wg, Dry Coil)

ROWS	FINS	FACE VELOCITY (fpm)				
		300	400	500	600	700
4	8	0.15	0.25	0.37	0.51	0.66
	11	0.19	0.31	0.45	0.61	0.79
	14	0.23	0.36	0.52	0.70	0.90
6	8	0.23	0.38	0.55	0.76	1.00
	11	0.29	0.46	0.67	0.91	1.18
	14	0.34	0.55	0.79	1.06	1.36
8	8	0.30	0.50	0.74	1.02	1.33
	11	0.38	0.62	0.90	1.22	1.57
	14	0.46	0.73	1.05	1.41	1.81
10	8	0.38	0.63	0.92	1.27	1.66
	11	0.48	0.77	1.12	1.52	1.97
	14	0.57	0.91	1.31	1.76	2.26

## HEATING COIL AIR FRICTION (in. wg)

ROWS	FINS	FACE VELOCITY (fpm)									
		300	400	500	600	700	800	900	1000	1100	
1 or 2	8	0.08	0.13	0.19	0.26	0.34	0.43	0.53	0.64	0.75	
	11	0.09	0.15	0.22	0.30	0.39	0.50	0.61	0.72	0.85	
	14	0.12	0.19	0.27	0.37	0.47	0.59	0.71	0.85	0.99	
4	8	0.15	0.25	0.37	0.51	0.66	—	—	—	—	
	11	0.19	0.31	0.45	0.61	0.79	—	—	—	—	
	14	0.23	0.36	0.52	0.70	0.90	—	—	—	—	

## STEAM COIL AIR FRICTION (in. wg)

ROWS	FINS	FACE VELOCITY (fpm)										
		300	400	500	600	700	800	900	1000	1100	1200	
1 or 2	6	0.03	0.05	0.07	0.10	0.13	0.16	0.20	0.25	0.29	0.34	
	9	0.07	0.11	0.17	0.22	0.30	0.38	0.46	0.55	0.65	0.76	
	12	0.12	0.18	0.27	0.37	0.47	0.58	0.72	0.85	1.01	1.15	

# Physical data (cont)



## ELECTRIC HEATER DATA

39M UNIT SIZE	HEATER AREA (sq ft)	NO. OF CONTROL STEPS*	HEATER COIL KW	NOMINAL COIL FACE VELOCITY (fpm)	TEMP RISE (F)	208/3/60 VOLTS				240/3/60 VOLTS				480/3/60 VOLTS				600/3/60 VOLTS				380/3/50 VOLTS				
						Total FLA	MCA†	No. Sub Ckt	MOCP	Total FLA	MCA†	No. Sub Ckt	MOCP	Total FLA	MCA†	No. Sub Ckt	MOCP	Total FLA	MCA†	No. Sub Ckt	MOCP	Total FLA	MCA†	No. Sub Ckt	MOCP	
03W	3	3	5	500	11	14	17	1	20	12	15	1	20	6	8	1	20	5	6	1	20	8	10	1	20	
			10	500	21	28	35	1	35	24	30	1	35	12	15	1	20	10	12	1	20	15	19	1	20	
			15	500	32	42	52	1	60	36	45	1	50	18	23	1	25	14	18	1	20	23	29	1	30	
			20	500	43	56	69	2	70	48	60	2	70	24	30	1	35	19	24	1	25	30	38	1	40	
			25	500	53	69	87	2	90	60	75	2	80	30	38	1	40	24	30	1	35	38	48	1	50	
			30	500	64	83	104	2	110	72	90	2	100	36	45	1	50	29	36	1	40	46	57	1	60	
			35	500	75	97	122	3	125	84	105	2	110	42	53	1	60	34	42	1	45	53	67	2	70	
06W	5.2	3	10	500	12	28	35	1	35	24	30	1	35	12	15	1	20	10	12	1	20	15	19	1	20	
			15	500	18	42	52	1	60	36	45	1	50	18	23	1	25	14	18	1	20	23	29	1	30	
			20	500	25	56	69	2	70	48	60	2	70	24	30	1	35	19	24	1	25	30	38	1	40	
			30	500	37	83	104	2	110	72	90	2	100	36	45	1	50	29	36	1	40	46	57	1	60	
			40	500	49	111	139	3	150	96	120	3	125	48	60	2	70	39	48	1	50	61	76	2	80	
			50	500	61	139	174	3	175	120	151	3	175	60	75	2	80	48	60	2	70	76	95	2	100	
			60	500	74	167	208	4	225	145	181	4	200	72	90	2	100	58	72	2	80	91	114	2	125	
08W	7.4	3	20	500	17	56	69	2	70	48	60	2	70	24	30	1	35	19	24	1	25	30	38	1	40	
			30	500	26	83	104	2	110	72	90	2	100	36	45	1	50	29	36	1	40	46	57	1	60	
			40	500	35	111	139	3	150	96	120	3	125	48	60	2	70	39	48	1	50	61	76	2	80	
			50	500	43	139	174	3	175	120	151	3	175	60	75	2	80	48	60	2	70	76	95	2	100	
			60	500	52	167	208	4	225	145	181	4	200	72	90	2	100	58	72	2	80	91	114	2	125	
			70	500	60	195	243	5	250	169	211	4	225	84	105	2	110	67	84	2	90	106	133	3	150	
			80	500	69	222	278	5	300	193	241	5	250	96	120	3	125	77	96	2	100	122	152	3	175	
10W	9.9	3	20	500	13	56	69	2	70	48	60	2	70	24	30	1	35	19	24	1	25	30	38	1	40	
			30	500	19	83	104	2	110	72	90	2	100	36	45	1	50	29	36	1	40	46	57	1	60	
			40	500	26	111	139	3	150	96	120	3	125	48	60	2	70	39	48	1	50	61	76	2	80	
			50	500	32	139	174	3	175	120	151	3	175	60	75	2	80	48	60	2	70	76	95	2	100	
			60	500	39	167	208	4	225	145	181	4	200	72	90	2	100	58	72	2	80	91	114	2	125	
			75	500	48	208	261	5	300	181	226	4	250	90	113	2	125	72	90	2	100	114	143	3	150	
			90	500	58	250	313	6	350	217	271	5	300	108	135	3	150	87	108	2	110	137	171	3	175	
12W	12.4	3	100	500	65	278	347	6	350	241	301	6	350	120	151	3	175	96	120	3	125	152	190	4	200	
			20	500	10	56	69	2	70	48	60	2	70	24	30	1	35	19	24	1	25	30	38	1	40	
			30	500	15	83	104	2	110	72	90	2	100	36	45	1	50	29	36	1	40	46	57	1	60	
			40	500	21	111	139	3	150	96	120	3	125	48	60	2	70	39	48	1	50	61	76	2	80	
			50	500	26	139	174	3	175	120	151	3	175	60	75	2	80	48	60	2	70	76	95	2	100	
			60	500	31	167	208	4	225	145	181	4	200	72	90	2	100	58	72	2	80	91	114	2	125	
			80	500	41	222	278	5	300	193	241	5	250	96	120	3	125	77	96	2	100	122	152	3	175	
14W	13.6	3	100	500	52	278	347	6	350	241	301	6	350	120	151	3	175	96	120	3	125	152	190	4	200	
			115	500	59	—	—	—	—	—	—	—	—	—	138	173	3	175	111	138	3	150	175	219	4	225
			130	500	67	—	—	—	—	—	—	—	—	—	157	196	4	200	125	157	3	175	198	247	5	250
			30	500	14	83	104	2	110	72	90	2	100	36	45	1	50	29	36	1	40	46	57	1	60	
			45	500	21	125	156	3	175	108	135	3	150	54	68	2	70	43	54	1	60	68	86	2	90	
			60	500	28	167	208	4	225	145	181	4	200	72	90	2	100	58	72	2	80	91	114	2	125	
			80	500	38	222	278	5	300	193	241	5	250	96	120	3	125	77	96	2	100	122	152	3	175	
16T	14.60	3	100	500	47	278	347	6	350	241	301	6	350	120	151	3	175	96	120	3	125	152	190	4	200	
			115	500	54	—	—	—	—	—	—	—	—	—	138	173	3	175	111	138	3	150	175	219	4	225
			130	500	61	—	—	—	—	—	—	—	—	—	157	196	4	200	125	157	3	175	198	247	5	250
			150	500	70	—	—	—	—	—	—	—	—	—	181	226	4	250	145	181	4	200	228	—	5	300
			30	500	13	83	104	2	110	72	90	2	100	36	45	1	50	29	36	1	40	46	57	1	60	
			45	500	20	125	156	3	175	108	135	3	150	54	68	2	70	43	54	1	60	68	86	2	90	
			60	500	26	167	208	4	225	144	180	4	200	72	90	2	100	58	72	2	80	91	114	2	125	
17W	16.6	3	75	500	33	208	260	5	300	180	226	4	250	90	113	2	125	72	90	2	100	114	142	3	150	
			80	500	35	222	278	5	300	193	241	5	250	96	120	3	125	77	96	2	100	122	152	3	175	
			100	500	44	278	347	6	350	241	301	6	300	120	150	3	175	96	120	3	125	152	190	3	200	
			120	500	52	—	—	—	—	—	—	—	—	—	144	180	4	200	115	144	3	175	182	228	4	250
			140	500	61	—	—	—	—	—	—	—	—	—	168	210	4	225	135	168	3	200	213	266	4	300
			160	500	70	—	—	—	—	—	—	—	—	—	192	241	5	250	154	192	4	225	243	266	5	300
			30	500	12	83	104	2	110	72	90	2	100	36	45	1	50	29	36	1	40	46	57	1	60	
17W	16.6	6	45	500	17	125	156	3	175	108	135	3	150	54	68	2	70	43	54	1	60	68	86	2	90	
			60	500	23	167	208	4	225	145	181	4	200	72	90	2	100	58	72	2	80	91	114	2	125	
			75	500	29	208	261	5	300	181	226	4	250	90	113	2	125	72	90	2	100	114	143	3	150	
			80	500	31	222																				

## ELECTRIC HEATER DATA (cont)

39M UNIT SIZE	HEATER AREA (sq ft)	NO. OF CONTROL STEPS*	HEATER COIL kW	NOMINAL COIL FACE VELOCITY (fpm)	TEMP RISE (F)	208/3/60 VOLTS				240/3/60 VOLTS				480/3/60 VOLTS				600/3/60 VOLTS				380/3/50 VOLTS						
						Total FLA	MCA †	No. Sub Ckt	MOCP	Total FLA	MCA †	No. Sub Ckt	MOCP	Total FLA	MCA †	No. Sub Ckt	MOCP	Total FLA	MCA †	No. Sub Ckt	MOCP	Total FLA	MCA †	No. Sub Ckt	MOCP			
18T	16.67	3	30	500	11	83	104	2	110	72	90	2	100	36	45	1	50	29	36	1	40	46	304	6	90			
			45	500	17	125	156	3	175	108	135	3	150	54	68	2	70	43	54	1	60	68	57	1	125			
			60	500	23	167	208	4	225	144	180	4	200	72	90	2	100	58	72	2	80	91	85	2	150			
		6	75	500	29	208	260	5	300	180	226	4	250	90	113	2	125	72	90	2	100	114	114	2	175			
			80	500	31	222	278	5	300	192	241	5	250	96	120	3	125	77	96	2	100	122	142	3	200			
			100	500	38	—	—	—	—	—	—	—	—	—	—	—	120	150	3	175	96	120	3	125	152	250		
			125	500	48	—	—	—	—	—	—	—	—	—	—	150	188	4	200	120	150	3	175	182	190	300		
			150	500	57	—	—	—	—	—	—	—	—	—	—	180	226	4	250	144	180	4	200	213	228	350		
			175	500	67	—	—	—	—	—	—	—	—	—	—	210	263	5	300	168	210	4	225	243	266	400		
			40	500	12	111	139	3	150	96	120	3	125	48	60	2	70	39	48	1	50	61	76	2	80			
21W	21	3	50	500	15	139	174	3	175	120	151	3	175	60	75	2	80	48	60	2	70	76	95	2	100			
			60	500	18	167	208	4	225	145	181	4	200	72	90	2	100	58	72	2	80	91	114	2	125			
			80	500	24	222	278	5	300	193	241	5	250	96	120	3	125	77	96	2	100	122	152	3	175			
		6	100	500	30	278	347	6	350	241	301	6	350	120	151	3	175	96	120	3	125	152	190	4	200			
			125	500	38	—	—	—	—	—	—	—	—	—	—	151	188	4	200	120	151	3	175	190	238	250		
			150	500	46	—	—	—	—	—	—	—	—	—	—	181	226	4	250	145	181	4	200	228	285	300		
			175	500	53	—	—	—	—	—	—	—	—	—	—	211	263	5	300	169	211	4	225	266	333	350		
			200	500	61	—	—	—	—	—	—	—	—	—	—	241	301	6	350	193	241	5	250	304	380	400		
			220	500	67	—	—	—	—	—	—	—	—	—	—	265	331	6	350	212	265	5	300	335	418	450		
			40	500	12	111	139	3	150	96	120	3	125	48	60	2	70	38	48	1	50	61	76	2	80			
22T	21.18	3	50	500	15	139	173	3	175	120	150	3	175	60	75	2	80	48	60	2	70	76	95	2	100			
			60	500	18	167	208	4	225	144	180	4	200	72	90	2	100	58	72	2	80	91	114	2	125			
			80	500	24	222	278	5	300	192	241	5	250	96	120	3	125	77	96	2	100	122	152	3	175			
		6	100	500	30	278	347	6	350	241	301	6	350	120	150	3	175	96	120	3	125	152	190	4	200			
			125	500	38	—	—	—	—	—	—	—	—	—	—	150	188	4	200	120	150	3	175	190	237	250		
			150	500	45	—	—	—	—	—	—	—	—	—	—	180	226	4	250	144	180	4	200	228	285	300		
			175	500	53	—	—	—	—	—	—	—	—	—	—	210	263	5	300	168	210	4	225	266	332	350		
			200	500	60	—	—	—	—	—	—	—	—	—	—	241	301	6	350	192	241	5	250	304	380	400		
			230	500	69	—	—	—	—	—	—	—	—	—	—	277	346	6	350	221	277	5	300	349	437	450		
			40	500	11	111	139	3	150	96	120	3	125	48	60	2	70	39	48	1	50	61	76	2	80			
25W	23.3	3	50	500	14	139	174	3	175	120	151	3	175	60	75	2	80	48	60	2	70	76	95	2	100			
			60	500	16	167	208	4	225	145	181	4	200	72	90	2	100	58	72	2	80	91	114	2	125			
			80	500	22	222	278	5	300	193	241	5	250	96	120	3	125	77	96	2	100	122	152	3	175			
		6	100	500	27	278	347	6	350	241	301	6	350	120	151	3	175	96	120	3	125	152	190	4	200			
			125	500	34	—	—	—	—	—	—	—	—	—	—	7	400	151	188	4	200	120	151	3	175	190	238	250
			150	500	41	—	—	—	—	—	—	—	—	—	—	8	500	181	226	4	250	145	181	4	200	228	285	300
			175	500	48	—	—	—	—	—	—	—	—	—	—	9	600	211	263	5	300	169	211	4	225	266	333	350
			200	500	55	—	—	—	—	—	—	—	—	—	—	11	700	241	301	6	350	193	241	5	250	304	380	400
			225	500	62	—	—	—	—	—	—	—	—	—	—	12	700	271	339	6	350	217	271	5	300	—	—	—
			250	500	69	—	—	—	—	—	—	—	—	—	—	13	700	301	376	7	400	241	301	6	350	—	—	—
25T	23.45	3	40	500	11	111	139	3	150	96	120	3	125	48	60	2	70	38	48	1	50	61	76	2	80			
			50	500	14	139	173	3	175	120	150	3	175	60	75	2	80	48	60	2	70	76	95	2	100			
			60	500	16	167	208	4	225	144	180	4	200	72	90	2	100	58	72	2	80	91	114	2	125			
		6	80	500	22	222	278	5	300	192	241	5	250	96	120	3	125	77	96	2	100	122	152	3	175			
			100	500	27	278	347	6	350	241	301	6	350	120	150	3	175	96	120	3	125	152	190	4	200			
			125	500	34	—	—	—	—	—	—	—	—	—	—	150	188	4	200	120	150	3	175	190	237	250		
			150	500	41	—	—	—	—	—	—	—	—	—	—	180	226	4	250	144	180	4	200	228	285	300		
			175	500	48	—	—	—	—	—	—	—	—	—	—	210	263	5	300	168	210	4	225	266	332	350		
			200	500	54	—	—	—	—	—	—	—	—	—	—	241	301	6	350	192	241	5	250	304	380	400		
			225	500	61	—	—	—	—	—	—	—	—	—	—	271	338	6	350	217	271	5	300	342	427	450		
30W	29.3	3	40	500	9	111	139	3	150	96	120	3	125	48	75	2	70	39	48	1	50	61	76	2	80			
			50	500	11	139	174	3	175	120	151	3	175	60	90	2	80	48	60	2	70	76	91	2	100			
			60	500	13	167	208	3	225	145	181	4	200	72	96	2	100	58	72	2	80	91	122	3	125			
		6	80	500	17	222	278	3	300	193	241	5	250	96	120	3	125	77	96	2	100	122	152	3	175			
			100	500	22	278	347	3	350	241	301	6	350	120	151	3	175	96	120	3	125	152	190	4	200			
			125	500	27	347	434	3	450	301	376	7	400	151	188	4	200	120	151	3	175	190	238	4	250			
			150	500	33	—	—	—	—	—	—	—	—	—	—	8	500	181	226	4	250	145	181	4	200	228	285	300
			175	500	38	—	—	—	—	—	—	—	—	—	—	9	600	211	263	5	300	169	211	4	225	266	333	350
			200	500	44	—	—	—	—	—	—	—	—	—	—	11	700	241	301	6	350	193	241	5	250	304	380	400
			225	500	49	—	—	—	—	—	—	—	—	—	—	12	700	271	339	6	350	217	271	5	300	—	—	—

**LEGEND**

AHRI — Air-Conditioning, Heating and Refrigeration Institute  
 FLA — Full Load Amps  
 MCA — Minimum Circuit Amps  
 MOCP — Maximum Overcurrent Protection

\*Standard control steps are listed under the Control Step heading. "Free" additional steps of control are optionally available when the number of subcircuits exceeds the standard number of control steps.

†MCA = 1.25 x FLA; for proper wire sizing, refer to Table 310-16 of the NEC (National Electrical Code).

**NOTES:**

Subcircuits are internal heater circuits of 48 amps or less.  
 Electric heat performance is not within the scope of AHRI standard 430 certification.  
 To avoid damage due to overheating, minimum face velocity cannot fall below 350 fpm.  
 Heaters up to (and including) 60 kW have 3 control steps; beyond 60 k, 6 steps are standard.  
 Heater kW offering is controlled by AHUBuilder® program This table for reference only.

# Physical data (cont)



## ELECTRIC HEATER DATA (cont)

39M UNIT SIZE	HEATER AREA (sq ft)	NO. OF CONTROL STEPS*	HEATER COIL KW	NOMINAL COIL FACE VELOCITY (fpm)	TEMP RISE (F)	208/3/60 VOLTS				240/3/60 VOLTS				480/3/60 VOLTS				600/3/60 VOLTS				380/3/50 VOLTS				
						Total FLA	MCA†	No. Sub Ckt	MOCP	Total FLA	MCA†	No. Sub Ckt	MOCP	Total FLA	MCA†	No. Sub Ckt	MOCP	Total FLA	MCA†	No. Sub Ckt	MOCP	Total FLA	MCA†	No. Sub Ckt	MOCP	
30T	29.05	3	40	500	11	111	139	3	150	96	120	3	125	48	60	2	70	38	48	1	50	61	76	2	80	
			50	500	14	139	173	3	175	120	150	3	175	60	75	2	80	48	60	2	70	76	95	2	100	
			60	500	16	167	208	4	225	144	180	4	200	72	90	2	100	58	72	2	80	91	114	2	125	
		6	80	500	22	222	278	5	300	192	241	5	250	96	120	3	125	77	96	2	100	122	152	3	175	
			100	500	27	278	347	6	350	241	301	6	350	120	150	3	175	96	120	3	125	152	190	4	200	
			125	500	34	—	—	—	—	—	—	—	—	—	150	188	4	200	120	150	3	175	190	237	4	250
			150	500	41	—	—	—	—	—	—	—	—	—	180	226	4	250	144	180	4	200	228	285	5	300
			175	500	48	—	—	—	—	—	—	—	—	—	210	263	5	300	168	210	4	225	266	332	6	350
			200	500	54	—	—	—	—	—	—	—	—	—	241	301	6	350	192	241	5	250	304	380	7	400
			225	500	61	—	—	—	—	—	—	—	—	—	271	338	6	350	217	271	5	300	342	427	8	450
			250	500	68	—	—	—	—	—	—	—	—	—	301	376	7	400	241	301	6	350	380	475	8	500
			275	500	75	—	—	—	—	—	—	—	—	—	331	413	7	450	265	331	6	350	—	—	—	—
35T	34.61	3	60	500	16	167	208	4	225	144	180	4	200	72	90	2	100	58	72	2	80	91	114	2	125	
			80	500	22	222	278	5	300	192	241	5	250	96	120	3	125	77	96	2	100	122	152	3	175	
			100	500	27	278	347	6	350	241	301	6	350	120	150	3	175	96	120	3	125	152	190	4	200	
		6	125	500	34	—	—	—	—	—	—	—	—	—	150	188	4	200	120	150	3	175	190	237	4	250
			150	500	41	—	—	—	—	—	—	—	—	—	180	226	4	250	144	180	4	200	228	285	5	300
			175	500	48	—	—	—	—	—	—	—	—	—	210	263	5	300	168	210	4	225	266	332	6	350
			200	500	54	—	—	—	—	—	—	—	—	—	241	301	6	350	192	241	5	250	304	380	7	400
			225	500	61	—	—	—	—	—	—	—	—	—	271	338	6	350	217	271	5	300	342	427	8	450
			250	500	68	—	—	—	—	—	—	—	—	—	301	376	7	400	241	301	6	350	380	475	8	500
			300	500	82	—	—	—	—	—	—	—	—	—	361	451	8	500	289	361	7	400	—	—	—	—
			350	500	95	—	—	—	—	—	—	—	—	—	421	526	9	600	337	421	8	450	—	—	—	—
			36W	38	6	60	500	10	167	208	4	225	145	181	4	200	72	90	2	100	58	72	2	80	91	114
80	500	13				222	278	5	300	193	241	5	250	96	120	3	125	77	96	2	100	122	152	3	175	
100	500	17				278	347	6	350	241	301	6	350	120	151	3	175	96	120	3	125	152	190	4	200	
6	125	500			21	—	—	—	—	—	—	—	—	—	151	188	4	200	120	151	3	175	190	238	4	250
	150	500			25	—	—	—	—	—	—	—	—	—	181	226	4	250	145	181	4	200	228	285	5	300
	175	500			29	—	—	—	—	—	—	—	—	—	211	263	5	300	169	211	4	225	266	333	6	350
	200	500			34	—	—	—	—	—	—	—	—	—	241	301	6	350	193	241	5	250	304	380	7	400
	225	500			38	—	—	—	—	—	—	—	—	—	271	339	6	350	217	271	5	300	342	428	8	450
	250	500			42	—	—	—	—	—	—	—	—	—	301	376	7	400	241	301	6	350	380	475	8	500
	300	500			50	—	—	—	—	—	—	—	—	—	361	452	8	500	289	361	7	400	—	—	—	—
	350	500			59	—	—	—	—	—	—	—	—	—	421	527	9	600	337	421	8	450	—	—	—	—
	37T	36.24			3	60	500	16	167	208	4	225	144	180	4	200	72	90	2	100	58	72	2	80	91	114
80			500	22		222	278	5	300	192	241	5	250	96	120	3	125	77	96	2	100	122	152	3	175	
100			500	27		278	347	6	350	241	301	6	350	120	150	3	175	96	120	3	125	152	190	4	200	
6			125	500	34	—	—	—	—	—	—	—	—	—	150	188	4	200	120	150	3	175	190	237	4	250
			150	500	41	—	—	—	—	—	—	—	—	—	180	226	4	250	144	180	4	200	228	285	5	300
			175	500	48	—	—	—	—	—	—	—	—	—	210	263	5	300	168	210	4	225	266	332	6	350
			200	500	54	—	—	—	—	—	—	—	—	—	241	301	6	350	192	241	5	250	304	380	7	400
			225	500	61	—	—	—	—	—	—	—	—	—	271	338	6	350	217	271	5	300	342	427	8	450
			250	500	68	—	—	—	—	—	—	—	—	—	301	376	7	400	241	301	6	350	380	475	8	500
			300	500	82	—	—	—	—	—	—	—	—	—	361	451	8	500	289	361	7	400	—	—	—	—
			350	500	95	—	—	—	—	—	—	—	—	—	421	526	9	600	337	421	8	450	—	—	—	—
			360	500	98	—	—	—	—	—	—	—	—	—	433	541	10	600	346	433	8	450	—	—	—	—
40W	41.9	6	60	500	9	167	208	4	225	145	181	4	200	72	90	2	100	58	72	2	80	91	114	2	125	
			80	500	12	222	278	5	300	193	241	5	250	96	120	3	125	77	96	2	100	122	152	3	175	
			100	500	15	278	347	6	350	241	301	6	350	120	151	3	175	96	120	3	125	152	190	4	200	
		6	125	500	19	—	—	—	—	—	—	—	—	—	151	188	4	200	120	151	3	175	190	238	4	250
			150	500	23	—	—	—	—	—	—	—	—	—	181	226	4	250	145	181	4	200	228	285	5	300
			175	500	27	—	—	—	—	—	—	—	—	—	211	263	5	300	169	211	4	225	266	333	6	350
			200	500	30	—	—	—	—	—	—	—	—	—	241	301	6	350	193	241	5	250	304	380	7	400
			250	500	38	—	—	—	—	—	—	—	—	—	301	376	7	400	241	301	6	350	380	475	8	500
			300	500	46	—	—	—	—	—	—	—	—	—	361	452	8	500	289	361	7	400	—	—	—	—
			350	500	53	—	—	—	—	—	—	—	—	—	421	527	9	600	337	421	8	450	—	—	—	—
			400	500	61	—	—	—	—	—	—	—	—	—	482	602	11	700	385	482	9	500	—	—	—	—

**LEGEND**

**AHRI** — Air-Conditioning, Heating and Refrigeration Institute  
**FLA** — Full Load Amps  
**MCA** — Minimum Circuit Amps  
**MOCP** — Maximum Overcurrent Protection

\*Standard control steps are listed under the Control Step heading. "Free" additional steps of control are optionally available when the number of subcircuits exceeds the standard number of control steps.

†MCA = 1.25 x FLA; for proper wire sizing, refer to Table 310-16 of the NEC (National Electrical Code).

**NOTES:**

Subcircuits are internal heater circuits of 48 amps or less.  
 Electric heat performance is not within the scope of AHRI standard 430 certification.  
 To avoid damage due to overheating, minimum face velocity cannot fall below 350 fpm.  
 Heaters up to (and including) 60 kW have 3 control steps; beyond 60 k, 6 steps are standard.  
 Heater kW offering is controlled by **AHUBuilder®** program This table for reference only.



### ELECTRIC HEATER DATA (cont)

39M UNIT SIZE	HEATER AREA (sq ft)	NO. OF CONTROL STEPS*	HEATER COIL kW	NOMINAL COIL FACE VELOCITY (fpm)	TEMP RISE (F)	208/3/60 VOLTS				240/3/60 VOLTS				480/3/60 VOLTS				600/3/60 VOLTS				380/3/50 VOLTS																		
						Total FLA	MCA†	No. Sub Ckt	MOCP	Total FLA	MCA†	No. Sub Ckt	MOCP	Total FLA	MCA†	No. Sub Ckt	MOCP	Total FLA	MCA†	No. Sub Ckt	MOCP	Total FLA	MCA†	No. Sub Ckt	MOCP															
						50W	52.6	6	60	500	7	167	208	4	225	145	181	4	200	72	90	2	100	58	72	2	80	91	114	2	125									
61W	63.1	6	60	500	6				167	208	4	225	145	181	4	200	72	90	2	100	58	72	2	80	91	114	2	125												
			72W	73.5	6				60	500	5	167	208	4	225	145	181	4	200	72	90	2	100	58	72	2	80	91	114	2	125									
									85W	86.9	6	60	500	4	167	208	4	225	145	181	4	200	72	90	2	100	58	72	2	80	91	114	2	125						
												96W	98.0	6	60	500	4	167	208	4	225	145	181	4	200	72	90	2	100	58	72	2	80	91	114	2	125			
															110W	112.3	6	60	500	3	167	208	4	225	145	181	4	200	72	90	2	100	58	72	2	80	91	114	2	125

**LEGEND**  
**AHRI** — Air-Conditioning, Heating and Refrigeration Institute  
**FLA** — Full Load Amps  
**MCA** — Minimum Circuit Amps  
**MOCP** — Maximum Overcurrent Protection

**NOTES:**  
 Subcircuits are internal heater circuits of 48 amps or less.  
 Electric heat performance is not within the scope of AHRI standard 430 certification.  
 To avoid damage due to overheating, minimum face velocity cannot fall below 350 fpm.  
 Heaters up to (and including) 60 kW have 3 control steps; beyond 60 k, 6 steps are standard.  
 Heater kW offering is controlled by **AHUBUILDER®** program This table for reference only.

\*Standard control steps are listed under the Control Step heading. "Free" additional steps of control are optionally available when the number of subcircuits exceeds the standard number of control steps.  
 †MCA = 1.25 x FLA; for proper wire sizing, refer to Table 310-16 of the NEC (National Electrical Code).

# Physical data (cont)



## FAN OFFERINGS BY UNIT SIZE AND TYPE

39M UNIT SIZE	FORWARD CURVE FANS											
	SUPPLY						RETURN / EXHAUST					
	FAN WHEEL	HP / FRAME		FAN WHEEL	HP / FRAME		FAN WHEEL	HP / FRAME		FAN WHEEL	HP / FRAME	
MAX		MIN	MAX		MIN	MAX		MIN	MAX		MIN	
03W	N/A	N/A	N/A	A9-4A	5 / 184T	0.5 / 56	N/A	N/A	N/A	A9-4A	5 / 184T	0.5 / 56
06W	A10-8A	5 / 184T	0.75 / 56	A10-8A	5 / 184T	0.75 / 56	A9-4A	5 / 184T	0.5 / 56	A10-8A	5 / 184T	0.75 / 56
08W	A10-8A	7.5 / 213T	3 / 182T	A12-12A	5 / 184T	0.75 / 56	A10-8A	7.5 / 213T	3 / 182T	A12-12A	5 / 184T	0.75 / 56
10W	A12-12A	10 / 215T	5 / 184T	A15-15A	5 / 184T	1 / 143T	A12-12A	10 / 215T	5 / 184T	A15-15A	5 / 184T	1 / 143T
12W	A12-11A	15 / 254T	5 / 184T	A15-15A	7.5 / 213T	1.5 / 145T	A12-12A	10 / 215T	5 / 184T	A15-15A	7.5 / 213T	1.5 / 145T
14W	A15-15A	15 / 254T	5 / 184T	A18-18A	7.5 / 213T	1.5 / 145T	A15-15A	15 / 254T	5 / 184T	A18-18A	7.5 / 213T	1.5 / 145T
16T	A-15-15A	5 / 184T	15 / 254T	A18-18A	1.5 / 145T	10 / 215T	A-15-15A	5 / 184T	15 / 254T	A18-18A	1.5 / 145T	10 / 215T
17W	A15-15A	25 / 284T	7.5 / 213T	A18-18A	10 / 215T	1.5 / 145T	A15-15A	25 / 284T	7.5 / 213T	A18-18A	10 / 215T	1.5 / 145T
18T	A-15-15A	7.5 / 213T	25 / 284T	A18-18A	1.5 / 145T	11 / 215T	A-15-15A	7.5 / 213T	25 / 284T	A18-18A	1.5 / 145T	11 / 215T
21W	A15-15A	25 / 284T	7.5 / 213T	A20-18A	15 / 254T	2 / 145T	A18-18A	10 / 215T	1.5 / 145T	A20-18A	15 / 254T	2 / 145T
22T	A-15-15A	7.5 / 213T	26 / 284T	A20-18A	2 / 145T	15 / 254T	A-15-15A	7.5 / 213T	26 / 284T	A20-18A	2 / 145T	15 / 254T
25T	A20-15A	10 / 215T	25 / 284T	A20-18A	3 / 145T	16 / 254T	A20-15A	10 / 215T	25 / 284T	A20-18A	3 / 145T	16 / 254T
25W	A20-15A	25 / 284T	10 / 215T	A20-18A	15 / 254T	2 / 145T	A18-18A	10 / 215T	1.5 / 145T	A20-18A	15 / 254T	2 / 145T
30T	A20-18H	10 / 215T	30 / 286T	A20-20H	3 / 182T	20 / 256T	A20-18H	10 / 215T	30 / 286T	A20-20H	3 / 182T	20 / 256T
30W	A20-18H	30 / 286T	10 / 215T	A20-20H	20 / 256T	3 / 182T	A20-18H	30 / 286T	10 / 215T	A20-20H	20 / 256T	3 / 182T
35T	A20-20H	3 / 182T	20 / 256T	A22-22H	15 / 254T	30 / 286T	A20-20H	3 / 182T	20 / 256T	A22-22H	15 / 254T	30 / 286T
36W	A22-22H	30 / 286T	15 / 254T	A25-25H	25 / 284T	3 / 182T	A20-20H	20 / 256T	3 / 182T	A25-25H	25 / 284T	3 / 182T
37T	A22-22H	15 / 254T	30 / 286T	A25-25H	3 / 182T	25 / 284T	A22-22H	15 / 254T	30 / 286T	A25-25H	3 / 182T	25 / 284T
40W	A25-20H	30 / 286T	15 / 254T	A25-25H	25 / 284T	3 / 182T	A20-20H	20 / 256T	3 / 182T	A25-25H	25 / 284T	3 / 182T
50W	A27-22H	40 / 324T	15 / 254T	A27-27H	30 / 286T	5 / 184T	A25-25H	25 / 284T	3 / 182T	A27-27H	30 / 286T	5 / 184T
61W	A27-27H	50 / 326T	20 / 256T	A30-30H	40 / 324T	5 / 184T	A27-27H	50 / 326T	20 / 256T	A30-30H	40 / 324T	5 / 184T
72W	32	75 / 365T	10 / 215T	36	75 / 365T	10 / 215T	32	75 / 365T	10 / 215T	36	75 / 365T	10 / 215T
85W	36	75 / 365T	10 / 215T	40	75 / 365T	10 / 215T	36	75 / 365T	10 / 215T	40	75 / 365T	10 / 215T
96W	N/A	N/A	N/A	40	75 / 365T	10 / 215T	N/A	N/A	N/A	40	75 / 365T	10 / 215T
110W	N/A	N/A	N/A	40	75 / 365T	10 / 215T	N/A	N/A	N/A	40	75 / 365T	10 / 215T

39M UNIT SIZE	AIRFOIL FANS											
	SUPPLY						RETURN / EXHAUST					
	FAN WHEEL	HP / FRAME		FAN WHEEL	HP / FRAME		FAN WHEEL	HP / FRAME		FAN WHEEL	HP / FRAME	
MAX		MIN	MAX		MIN	MAX		MIN	MAX		MIN	
03W	N/A	N/A	N/A	101	5 / 184T	0.5 / 56	N/A	N/A	N/A	101	5 / 184T	0.5 / 56
06W	101	5 / 184T	0.5 / 56	121	7.5 / 184T	0.5 / 56	101	5 / 184T	0.5 / 56	121	7.5 / 184T	0.5 / 56
08W	121	7.5 / 184T	0.5 / 56	131	10 / 215T	1 / 143T	121	7.5 / 184T	0.5 / 56	131	10 / 215T	1 / 143T
10W	121	7.5 / 184T	0.5 / 56	131	15 / 254T	1.5 / 145T	121	7.5 / 184T	0.5 / 56	131	15 / 254T	1.5 / 145T
12W	131	15 / 254T	1.5 / 145T	161	15 / 254T	1.5 / 145T	131	15 / 254T	1.5 / 145T	161	15 / 254T	1.5 / 145T
14W	131	15 / 254T	1.5 / 145T	161	20 / 256T	1.5 / 145T	131	15 / 254T	1.5 / 145T	161	20 / 256T	1.5 / 145T
16T	131	1.5 / 145T	15 / 254T	161	1.5 / 145T	20 / 256T	131	1.5 / 145T	15 / 254T	161	1.5 / 145T	20 / 256T
17W	161	20 / 256T	1.5 / 145T	181	20 / 256T	1.5 / 145T	161	20 / 256T	1.5 / 145T	181	20 / 256T	1.5 / 145T
18T	161	1.5 / 145T	20 / 256T	181	1.5 / 145T	20 / 256T	161	1.5 / 145T	20 / 256T	181	1.5 / 145T	20 / 256T
21W	181	20 / 256T	1.5 / 145T	201	25 / 284T	2 / 145T	181	20 / 256T	1.5 / 145T	201	25 / 284T	2 / 145T
22T	181	1.5 / 145T	20 / 256T	201	2 / 145T	25 / 284T	181	1.5 / 145T	20 / 256T	201	2 / 145T	25 / 284T
25T	201	2 / 145T	25 / 284T	221	2 / 145T	30 / 286T	201	2 / 145T	25 / 284T	221	2 / 145T	30 / 286T
25W	201	25 / 284T	2 / 145T	221	30 / 286T	2 / 145T	201	25 / 284T	2 / 145T	221	30 / 286T	2 / 145T
30T	221	3 / 182T	40 / 324T	221	5 / 184T	40 / 324T	221	3 / 182T	40 / 324T	221	5 / 184T	40 / 324T
30W	N/A	N/A	N/A	221	40 / 324T	3 / 182T	N/A	N/A	N/A	221	40 / 324T	3 / 182T
35T	241	5 / 184T	40 / 324T	271	3 / 182T	15 / 254T	241	5 / 184T	40 / 324T	271	3 / 182T	15 / 254T
36W	271	40 / 324T	3 / 182T	241	40 / 324T	5 / 184T	241	40 / 324T	5 / 184T	271	40 / 324T	3 / 182T
37T	241	5 / 184T	40 / 324T	271	3 / 182T	15 / 254T	241	5 / 184T	40 / 324T	271	3 / 182T	15 / 254T
40W	301	50 / 326T	3 / 182T	271	50 / 326T	5 / 184T	271	50 / 326T	5 / 184T	301	50 / 326T	3 / 182T
50W	331	60 / 364T	5 / 184T	301	60 / 364T	7.5 / 213T	301	60 / 364T	7.5 / 213T	331	60 / 364T	5 / 184T
61W	301	60 / 364T	7.5 / 213T	331	75 / 365T	7.5 / 213T	331	75 / 365T	7.5 / 213T	361	20 / 256T	5 / 184T
72W	32	75 / 365T	7.5 / 213T	36	100 / 405T	7.5 / 213T	32	75 / 365T	7.5 / 213T	36	100 / 405T	7.5 / 213T
85W	36	100 / 405T	7.5 / 213T	40	125 / 444T	10 / 215T	36	100 / 405T	7.5 / 213T	40	125 / 444T	10 / 215T
96W	36	100 / 405T	7.5 / 213T	40	125 / 444T	10 / 215T	36	100 / 405T	7.5 / 213T	40	125 / 444T	10 / 215T
110W	40	125 / 444T	10 / 215T	44	150 / 445T	15 / 254T	40	125 / 444T	10 / 215T	44	150 / 445T	15 / 254T

### FAN OFFERINGS BY UNIT SIZE AND TYPE (cont)

39M UNIT SIZE	BELT DRIVE PLENUM FANS											
	SUPPLY						RETURN / EXHAUST					
	FAN WHEEL	HP / FRAME		FAN WHEEL	HP / FRAME		FAN WHEEL	HP / FRAME		FAN WHEEL	HP / FRAME	
MAX		MIN	MAX		MIN	MAX		MIN	MAX		MIN	
03W	N/A	N/A	N/A	123	5 / 184T	0.5 / 56	N/A	N/A	N/A	123	5 / 184T	0.5 / 56
06W	N/A	N/A	N/A	153	7.5 / 213T	.75 / 56	N/A	N/A	N/A	153	7.5 / 213T	.75 / 56
08W	153	7.5 / 213T	.75 / 56	163	10 / 215T	.75 / 56	153	7.5 / 213T	.75 / 56	163	10 / 215T	.75 / 56
10W	N/A	N/A	N/A	183Q	15 / 254T	1 / 143T	N/A	N/A	N/A	183Q	15 / 254T	1 / 143T
12W	N/A	N/A	N/A	223Q	20 / 256T	1 / 143T	N/A	N/A	N/A	223Q	20 / 256T	1 / 143T
14W	N/A	N/A	N/A	223Q	20 / 256T	1 / 143T	N/A	N/A	N/A	223Q	20 / 256T	1 / 143T
17W	223Q	20 / 256T	1 / 143T	243Q	20 / 256T	1.5 / 145T	223Q	20 / 256T	1 / 143T	243Q	20 / 256T	1.5 / 145T
21W	243Q	20 / 256T	1.5 / 145T	273Q	25 / 284T	2 / 145T	243Q	20 / 256T	1.5 / 145T	273Q	25 / 284T	2 / 145T
25W	273Q	25 / 284T	2 / 145T	303Q	25 / 284T	2 / 145T	273Q	25 / 284T	2 / 145T	303Q	25 / 284T	2 / 145T
30W	303Q	25 / 284T	2 / 145T	333Q	30 / 286T	3 / 182T	303Q	25 / 284T	2 / 145T	333Q	30 / 286T	3 / 182T
36W	333Q	30 / 286T	3 / 182T	363Q	40 / 324T	3 / 182T	333Q	30 / 286T	3 / 182T	363Q	40 / 324T	3 / 182T
40W	333Q	30 / 286T	3 / 182T	363Q	40 / 324T	3 / 182T	363Q	40 / 324T	3 / 182T	403Q	20 / 256T	3 / 182T
50W	363Q	40 / 324T	3 / 182T	403Q	50 / 326T	7.5 / 213T	403Q	50 / 326T	7.5 / 213T	443Q	60 / 364T	5 / 184T
61W	403Q	50 / 326T	7.5 / 213T	443Q	60 / 364T	5 / 184T	443Q	60 / 364T	5 / 184T	493Q	30 / 286T	5 / 184T
72W	40HE	75 / 365T	7.5 / 213T	44HE	100 / 405T	7.5 / 213T	40HE	75 / 365T	7.5 / 213T	44HE	100 / 405T	7.5 / 213T
85W	44HE	100 / 405T	7.5 / 213T	49HE	125 / 444T	10 / 215T	44HE	100 / 405T	7.5 / 213T	49HE	125 / 444T	10 / 215T
96W	49HE	125 / 444T	10 / 215T	55HE	150 / 445T	15 / 254T	49HE	125 / 444T	10 / 215T	55HE	150 / 445T	15 / 254T
110W	49HE	125 / 444T	10 / 215T	55HE	150 / 445T	15 / 254T	49HE	125 / 444T	10 / 215T	55HE	150 / 445T	15 / 254T

39M UNIT SIZE	DIRECT DRIVE PLENUM FANS								
	SUPPLY/RETURN/EXHAUST								
	FAN WHEEL	HP / FRAME		FAN WHEEL	HP / FRAME		FAN WHEEL	HP / FRAME	
MAX		MIN	MAX		MIN	MAX		MIN	
03W	105	5 / 184T	0.5 / 56	122	5 / 184T	0.5 / 56	N/A	N/A	N/A
06W	135	7.5 / 213T	1 / 143T	150	7.5 / 215T	1 / 143T	165	10 / 215T	1 / 143T
08W	150	7.5 / 215T	1 / 143T	165	10 / 215T	1 / 143T	182	15 / 254T	1 / 143T
10W	165	10 / 215T	1 / 143T	182	15 / 254T	1 / 143T	200	15 / 256T	1 / 143T
12W	182	15 / 254T	1 / 143T	200	15 / 254T	1 / 143T	222	20 / 256T	1 / 143T
14W	200	15 / 254T	1 / 143T	222	20 / 256T	1 / 143T	245	20 / 256T	1.5 / 182T
16T	200	15 / 256T	1 / 143T	222	20 / 256T	1 / 143T	245	20 / 256	1.5 / 182T
17W	222	20 / 256T	1 / 143T	245	20 / 256T	1.5 / 182T	270	25 / 284T	2 / 184T
18T	222	20 / 256T	1 / 143T	245	20 / 256T	1.5 / 182T	270	25 / 284T	2 / 184T
21W	245	20 / 256T	1.5 / 182T	270	25 / 284T	2 / 184T	300	30 / 324T	3 / 213T
22T	245	20 / 256T	1.5 / 182T	270	25 / 284T	2 / 184T	300	30 / 286T	3 / 213T
25T	270	25 / 284T	2 / 184T	300	30 / 286T	3 / 213T	330	40 / 364T	5 / 215T
25W	270	25 / 284T	2 / 184T	300	30 / 326T	3 / 213T	330	40 / 364T	5 / 215T
30T	270	25 / 284T	2 / 184T	330	40 / 364T	5 / 215T	365	50 / 364T	10 / 256T
30W	270	25 / 284T	2 / 184T	330	40 / 364T	6 / 215T	365	50 / 364T	10 / 256T
35T	300	30 / 286T	3 / 213T	330	40 / 364T	5 / 215T	365	50 / 364T	10 / 256T
36W	300	30 / 326T	3 / 213T	365	50 / 364T	10 / 256T	402	50 / 365T	10 / 256T
37T	330	40 / 364T	5 / 215T	365	50 / 364T	10 / 256T	402	50 / 365T	10 / 256T
40W	330	40 / 364T	5 / 215T	365	50 / 364T	10 / 256T	402	50 / 365T	10 / 256T
50W	365	50 / 364T	10 / 256T	402	50 / 365T	10 / 256T	N/A	N/A	N/A
61W	365	50 / 364T	10 / 256T	402	50 / 365T	10 / 256T	N/A	N/A	N/A

39M UNIT SIZE	DIRECT DRIVE PLENUM FAN ARRAYS								
	SUPPLY/RETURN/EXHAUST								
	2 FAN WHEELS	HP / FRAME		4 FAN WHEELS	HP / FRAME		6 FAN WHEELS	HP / FRAME	
MAX		MIN	MAX		MIN	MAX		MIN	
08W	135	7.5 / 213T	1 / 143T	N/A	N/A	N/A	N/A	N/A	N/A
10W	150	7.5 / 215T	1 / 143T	N/A	N/A	N/A	N/A	N/A	N/A
12W	165	10 / 215T	1 / 143T	N/A	N/A	N/A	N/A	N/A	N/A
14W	165	10 / 215T	1 / 143T	N/A	N/A	N/A	N/A	N/A	N/A
17W	182	15 / 254T	1 / 143T	N/A	N/A	N/A	N/A	N/A	N/A
21W	182	15 / 254T	1 / 143T	N/A	N/A	N/A	N/A	N/A	N/A
25W	222	20 / 256T	1 / 143T	N/A	N/A	N/A	N/A	N/A	N/A
30W	222	20 / 256T	1 / 143T	N/A	N/A	N/A	N/A	N/A	N/A
36W	270	25 / 284T	5 / 184T	N/A	N/A	N/A	N/A	N/A	N/A
40W	270	25 / 284T	5 / 184T	182	15 / 254T	1 / 143T	N/A	N/A	N/A
50W	300	30 / 324T	7.5 / 213T	222	20 / 256T	1 / 143T	182	15 / 254T	1 / 143T
61W	330	40 / 364T	10 / 215T	245	20 / 256T	3 / 182T	182	15 / 254T	1 / 143T
72W	365	50 / 364T	20 / 256T	N/A	N/A	N/A	222	20 / 256T	1 / 143T
85W	402	50 / 365T	20 / 256T	N/A	N/A	N/A	245	20 / 256T	3 / 182T
96W	N/A	N/A	N/A	N/A	N/A	N/A	245	20 / 256T	3 / 182T
110W	N/A	N/A	N/A	N/A	N/A	N/A	245	20 / 256T	3 / 182T

# Physical data (cont)



## → FAN DATA BY WHEEL DIAMETER AND TYPE

FORWARD CURVE FANS										
Fan Wheel	Wheel Diameter (in.)	Inlet Cone Diameter (in.)	Max Speed (rpm)		Fan Shaft Diameter (in.)*		Fan Wheel Weight (lb)		Number of Fan Blades	K Factor
			Class 1	Class 2	Class 1	Class 2	Class 1	Class 2		
A9-4A	9 1/2	7 13/16	2132	2749	3/4	3/4	4	4	43	†
A10-8A	10 5/8	8 13/16	1806	2347	3/4	1	6	6	48	†
A12-11A	12 5/8	10 3/8	1533	1986	1	1 3/16	10	10	43	†
A12-12A	12 5/8	10 3/8	1491	1938	1	1 3/16	10	10	43	†
A15-15A	15	12 5/8	1262	1639	1 3/16	1 3/16	16	17	51	†
A18-18A	18 1/32	15 1/2	1097	1378	1 3/16	1 7/16	32	34	48	†
A20-15A	20	16 1/4	969	1238	1 7/16	1 11/16	51	51	37	†
A20-18A	20	16 1/4	960	1217	1 7/16	1 11/16	53	53	37	†
A20-18H	20	16 1/4	952	1237	1 3/16	1 7/16	42	45	51	†
A20-20H	20	16 1/4	952	1237	1 3/16	1 7/16	42	45	51	†
A22-22H	22 3/8	18 1/16	884	1119	1 7/16	2 3/16	63	63	37	†
A25-20H	25	21 5/16	770	980	1 11/16	2 7/16	73	73	37	†
A25-25H	25	21 5/16	751	960	1 11/16	2 7/16	81	81	37	†
A27-22H	27 5/8	23 15/16	684	873	1 11/16	2 7/16	101	101	37	†
A27-27H	27 5/8	23 15/16	656	865	1 11/16	2 7/16	111	111	37	†
A30-30H	30 1/4	26 3/8	618	793	1 11/16	2 11/16	128	128	37	†
32	31 1/2	25 3/4	675	760	2 3/16	2 3/16	132	134	38	23,750
36	35 7/16	29	600	660	2 7/16	2 7/16	158	178	42	31,300
40	39	32 3/4	550	600	2 7/16	2 7/16	194	214	48	37,650

\* Minimum motor shaft diameter listed.

† Calculate from air balance data.

AIRFOIL FANS										
Fan Wheel	Wheel Diameter (in.)	Inlet Cone Diameter (in.)	Max Speed (rpm)		Fan Shaft Diameter (in.)*		Fan Wheel Weight (lb)		Number of Fan Blades	K Factor
			Class 1	Class 2	Class 1	Class 2	Class 1	Class 2		
101	10	6 1/8	N/A	4655	N/A	1	N/A	8	18	631
121	12 1/4	7 1/2	N/A	4560	N/A	1 3/16	N/A	11	18	890
131	13 1/2	8 3/8	N/A	4033	N/A	1 7/16	N/A	15	18	1,098
161	16 1/2	10 1/8	N/A	3254	N/A	1 11/16	N/A	37	18	1,560
181	18 1/4	11	2261	2950	1 11/16	1 15/16	52	52	20	1,816
201	20	12 7/16	2019	2598	1 11/16	1 15/16	60	60	20	2,279
221	22 1/4	13 7/8	1872	2442	1 15/16	2 3/16	73	73	20	2,798
241	24 1/2	15 1/8	1701	2218	2 3/16	2 7/16	88	91	20	3,286
271	27	16 13/16	1463	1910	2 3/16	2 7/16	104	106	20	3,992
301	30	18 13/16	1316	1715	2 7/16	2 11/16	136	145	20	4,961
331	33	20 9/16	1202	1568	2 7/16	2 15/16	168	176	20	5,895
361	36 1/2	23 1/8	1055	1378	2 11/16	2 15/16	235	233	18	7,277
32	31 7/8	21 5/8	1300	1700	2 3/16	2 7/16	195	195	10	14,035
36	35 13/16	24	1250	1550	2 7/16	2 3/4	262	273	10	18,400
40	39 3/8	26 7/8	1200	1350	2 3/4	2 15/16	348	358	10	22,750
44	44 3/32	30	850	1150	2 15/16	3 3/16	441	459	10	28,650

BELT DRIVE PLENUM FANS										
Fan Wheel	Wheel Diameter (in.)	Inlet Cone Diameter (in.)	Max Speed (rpm)		Fan Shaft Diameter (in.)*		Fan Wheel Weight (lb)		Number of Fan Blades	K Factor
			Class 1	Class 2	Class 1	Class 2	Class 1	Class 2		
123	12 1/4	7 1/2	3567	4655	1	1 3/16	8	8	9	890
153	15	9 1/4	2765	3610	1	1 3/16	13	13	9	1,314
163	16 1/2	10 1/8	2465	3216	1	1	27	27	9	1,560
183Q	18 1/4	11 15/17	2190	2855	1	1 3/16	35	35	12	2,118
223Q	22 1/4	14 1/2	1872	2442	1 7/16	1 7/16	50	50	12	3,056
243Q	24 1/2	15 67/83	1701	2218	1 7/16	1 7/16	70	70	12	4,333
273Q	27	17 17/33	1463	1910	1 7/16	1 7/16	80	80	12	4,333
303Q	30	19 11/16	1316	1715	1 7/16	1 7/16	100	100	12	5,434
333Q	33	21 33/68	1202	1568	1 11/16	1 11/16	135	135	12	6,436
363Q	36 1/2	24	1055	1378	1 11/16	1 11/16	171	171	12	7,836
403Q	40 1/4	26 5/8	955	1249	1 15/16	1 15/16	203	203	12	10,207
443Q	44 1/2	29 1/2	865	1131	2 3/16	2 3/16	277	277	12	12,324
493Q	49	32 1/2	808	1050	2 11/16	2 11/16	366	366	12	15,442
40HE	40	26 7/8	1150	1400	2 7/16	2 7/16	250	257	10	13,025
44HE	44 3/4	30	1100	1200	2 3/16	2 7/16	356	360	10	14,600
49HE	49 13/16	33 7/16	950	1100	2 7/16	2 7/16	454	454	10	17,550
55HE	55 1/4	37 1/16	850	975	2 15/16	2 15/16	651	651	10	21,370

### FAN DATA BY WHEEL DIAMETER AND TYPE (cont)

DIRECT DRIVE PLENUM FANS							
Fan Wheel	Wheel Diameter (in.)	Inlet Cone Diameter (in.)	Max Speed (rpm) Class 2	Motor Shaft Diameter (in.)* Class 2	Fan Wheel Weight (lb) Class 2	Number of Fan Blades	K Factor
105	10 1/2	6 31/50	5195	5/8	4	9	592
122	12 1/5	7 18/25	4425	5/8	5	9	842
135	13 1/2	8 1/2	4038	7/8	7	9	963
150	15	9 11/25	3650	7/8	11	9	1147
165	16 1/2	10 16/39	3275	7/8	13	9	1450
182	18 1/5	11 1/2	2979	7/8	17	9	1571
200	20	12 23/39	2771	7/8	19	9	2087
222	22 1/5	14 2/67	2454	7/8	26	9	2458
245	24 1/2	15 11/25	2269	1 1/8	32	9	2941
270	27	17 1/33	2035	1 1/8	45	9	3597
300	30	18 47/50	1851	1 3/8	63	9	4641
330	33	20 17/21	1620	1 3/8	75	9	5352
365	36 1/2	23	1465	1 5/8	93	9	6629
402	40 1/5	25 19/50	1330	1 5/8	120	9	7943

\* Minimum fan shaft diameter listed. Refer to centerline distance table for specific diameter by unit size.

† Calculate from air balance data.



# Physical data (cont)



## DIRECT-EXPANSION CIRCUITING DATA MEDIUM FACE AREA COILS

39M UNIT SIZE	03W			06W			08W			10W			12W			14W		
	Quarter	Half	Full	Quarter	Half	Full	Quarter	Half	Full	Quarter	Half	Full	Quarter	Half	Full	Quarter	Half	Full
<b>CIRCUITING TYPE</b>																		
Airflow (cfm) at 500 fpm	1,215			2,066			2,778			3,611			4,965			6,146		
Total Face Area (sq ft)	2.4			4.1			5.6			7.2			9.9			12.3		
Tubes in Face	14	14	14	14	14	14	16	16	16	16	16	16	22	22	22	24	24	24
Tube Length (in.)	20	20	20	34	34	34	40	40	40	52	52	52	52	52	52	59	59	59
No. of Circuits - Total	4	7	14	4	7	14	4	8	16	4	8	16	6	11	22	6	12	24
<b>4-Row Coil</b>																		
<b>Face Split Coils</b>																		
No. of TXVs	2	2	—	2	2	—	2	2	—	2	2	—	2	2	2	2	2	2
Suction Connections (in. OD)	7/8	7/8	—	7/8	7/8	—	7/8	7/8	—	7/8	7/8	—	7/8	1 1/8	1 3/8	7/8	1 1/8	1 3/8
Distributor Connections (in. OD)	7/8	7/8	—	7/8	7/8	—	7/8	7/8	—	7/8	7/8	—	7/8	7/8	1 1/8	7/8	7/8	1 3/8
Distributor Nozzle Size*	G-1.5	G-2.5/G-2	—	G-1.5	G-2.5/G-2	—	G-1.5	G-2.5	—	G-1.5	G-2.5	—	G-2	G-4/G-3	E-12	G-2	G-4	C-12
<b>Intertwined Row Split Coils</b>																		
No. of TXVs	2	2	—	2	2	—	2	2	—	2	2	—	2	2	—	2	2	—
Suction Connections (in. OD)	7/8	7/8	—	7/8	7/8	—	7/8	7/8	—	7/8	7/8	—	7/8	1 1/8	—	7/8	1 1/8	—
Distributor Connections (in. OD)	7/8	7/8	—	7/8	7/8	—	7/8	7/8	—	7/8	7/8	—	7/8	7/8	—	7/8	7/8	—
Distributor Nozzle Size*	G-1.5	G-2.5/G-2	—	G-1.5	G-2.5/G-2	—	G-1.5	G-2.5	—	G-1.5	G-2.5	—	G-2	G-4/G-3	—	G-2	G-4	—
<b>Single-Circuit Coils</b>																		
No. of TXVs	1	1	—	1	1	—	1	1	—	1	1	—	1	1	—	1	1	—
Suction Connections (in. OD)	7/8	1 1/8	—	7/8	1 1/8	—	7/8	1 1/8	—	7/8	1 1/8	—	1 1/8	1 3/8	—	1 1/8	1 3/8	—
Distributor Connections (in. OD)	7/8	7/8	—	7/8	7/8	—	7/8	7/8	—	7/8	7/8	—	7/8	1 1/8	—	7/8	1 3/8	—
Distributor Nozzle Size	G-2.5	G-6	—	G-2.5	G-6	—	G-2.5	G-8	—	G-2.5	G-8	—	G-4	E-12	—	G-4	C-12	—
<b>6-Row Coil</b>																		
<b>Face Split Coils</b>																		
No. of TXVs	2	2	—	2	2	—	2	2	2	2	2	2	2	2	—	2	2	2
Suction Connections (in. OD)	7/8	7/8	—	7/8	7/8	—	7/8	7/8	1 1/8	7/8	7/8	1 1/8	7/8	1 1/8	1 3/8	—	1 1/8	1 3/8
Distributor Connections (in. OD)	7/8	7/8	—	7/8	7/8	—	7/8	7/8	7/8	7/8	7/8	—	7/8	7/8	1 1/8	—	7/8	1 3/8
Distributor Nozzle Size*	G-1.5	G-2.5/G-2	—	G-1.5	G-2.5/G-2	—	G-1.5	G-2.5	G-8	G-1.5	G-2.5	G-8	G-2	G-4/G-3	E-12	—	G-4	C-12
<b>Intertwined Row Split Coils</b>																		
No. of TXVs	2	2	—	2	2	—	2	2	—	2	2	—	2	2	—	2	2	—
Suction Connections (in. OD)	7/8	7/8	—	7/8	7/8	—	7/8	7/8	—	7/8	7/8	—	7/8	1 1/8	1 3/8	—	1 1/8	1 3/8
Distributor Connections (in. OD)	7/8	7/8	—	7/8	7/8	—	7/8	7/8	—	7/8	7/8	—	7/8	7/8	1 1/8	—	7/8	1 3/8
Distributor Nozzle Size*	G-1.5	G-2.5/G-2	—	G-1.5	G-2.5/G-2	—	G-1.5	G-2.5	—	G-1.5	G-2.5	—	G-2	G-4/G-3	E-12	—	G-4	C-12
<b>Single-Circuit Coils</b>																		
No. of TXVs	1	1	—	1	1	—	1	1	—	1	1	—	1	1	—	1	1	—
Suction Connections (in. OD)	7/8	1 1/8	—	7/8	1 1/8	—	7/8	1 1/8	—	7/8	1 1/8	—	1 1/8	1 3/8	—	1 1/8	1 3/8	—
Distributor Connections (in. OD)	7/8	7/8	—	7/8	7/8	—	7/8	7/8	—	7/8	7/8	—	7/8	1 1/8	—	7/8	1 3/8	—
Distributor Nozzle Size	G-2.5	G-6	—	G-2.5	G-6	—	G-2.5	G-8	—	G-2.5	G-8	—	G-4	E-12	—	—	C-12	—
<b>8-Row Coil</b>																		
<b>Face Split Coils</b>																		
No. of TXVs	—	2	2	—	2	2	—	2	2	—	2	2	—	2	2	—	2	2
Suction Connections (in. OD)	—	7/8	1 1/8	—	7/8	1 1/8	—	7/8	1 1/8	—	7/8	1 1/8	—	1 1/8	1 3/8	—	1 1/8	1 3/8
Distributor Connections (in. OD)	—	7/8	7/8	—	7/8	7/8	—	7/8	7/8	—	7/8	7/8	—	7/8	1 1/8	—	7/8	1 3/8
Distributor Nozzle Size*	—	G-2.5/G-2	G-6	—	G-2.5/G-2	G-6	—	G-2.5	G-8	—	G-2.5	G-8	—	G-4/G-3	E-12	—	G-4	C-12
<b>Intertwined Row Split Coils</b>																		
No. of TXVs	—	2	—	—	2	2	—	2	2	—	2	2	—	2	2	—	2	2
Suction Connections (in. OD)	—	7/8	—	—	7/8	1 1/8	—	7/8	1 1/8	—	7/8	1 1/8	—	1 1/8	1 3/8	—	1 1/8	1 3/8
Distributor Connections (in. OD)	—	7/8	—	—	7/8	7/8	—	7/8	7/8	—	7/8	7/8	—	7/8	1 1/8	—	7/8	1 3/8
Distributor Nozzle Size*	—	G-2.5/G-2	—	—	G-2.5/G-2	G-6	—	G-2.5	G-8	—	G-2.5	G-8	—	G-4/G-3	E-12	—	G-4	C-12
<b>Single-Circuit Coils</b>																		
No. of TXVs	1	1	—	—	1	—	—	1	—	—	1	—	—	1	—	—	1	—
Suction Connections (in. OD)	7/8	1 1/8	—	—	1 1/8	—	—	1 1/8	—	—	1 1/8	—	—	1 3/8	—	—	1 3/8	—
Distributor Connections (in. OD)	7/8	7/8	—	—	7/8	—	—	7/8	—	—	7/8	—	—	1 1/8	—	—	1 3/8	—
Distributor Nozzle Size	G-2.5	G-6	—	—	G-6	—	—	G-8	—	—	G-8	—	—	E-12	—	—	C-12	—

**LEGEND**

TXV — Thermostatic Expansion Valve (Field Supplied)

\*When 2 nozzle sizes are listed, the smaller nozzle should be located on the upper distributor.

NOTE: Factory-supplied distributors have factory-selected nozzle sizes as shown. If necessary, replace factory-supplied nozzles with field-supplied and field-installed nozzles. Consult **AHUBuilder®** software selection program for correct nozzle selection.

→ DIRECT-EXPANSION CIRCUITING DATA (cont)  
MEDIUM FACE AREA COILS (cont)

39M UNIT SIZE	16T								17W		18T			
	Quarter		Half		Full		Double		Half	Full	Half		Full	
Airflow (cfm) at 500 fpm	5,938								6,771		7,474			
Total Face Area (sq ft)	11.9								13.5		14.9			
	Upper	Lower	Upper	Lower	Upper	Lower	Upper	Lower			Upper	Lower	Upper	Lower
Tubes in Face	36	36	36	36	36	36	36	36	24	65	42	42	42	42
Tube Length (in.)	38	38	38	38	38	38	38	38	12	24	41	41	41	41
No. of Circuits - Total	9	9	18	18	36	36	72	72			21	21	42	42
<b>4-Row Coil</b>														
<b>Face Split Coils</b>														
No. of TXVs	2	2	2	2	2	2	—	—	2	2	2	2	4	4
Suction Connections (in. OD)	1 <sup>5</sup> / <sub>8</sub>	1 <sup>5</sup> / <sub>8</sub>	1 <sup>3</sup> / <sub>8</sub>	1 <sup>3</sup> / <sub>8</sub>	1 <sup>5</sup> / <sub>8</sub>	1 <sup>5</sup> / <sub>8</sub>	—	—	1 <sup>1</sup> / <sub>8</sub>	1 <sup>3</sup> / <sub>8</sub>	1 <sup>5</sup> / <sub>8</sub>	1 <sup>5</sup> / <sub>8</sub>	1 <sup>5</sup> / <sub>8</sub>	1 <sup>5</sup> / <sub>8</sub>
Distributor Connections (in. OD)	1 <sup>3</sup> / <sub>8</sub>	1 <sup>3</sup> / <sub>8</sub>	1 <sup>1</sup> / <sub>8</sub>	1 <sup>1</sup> / <sub>8</sub>	1 <sup>3</sup> / <sub>8</sub>	1 <sup>3</sup> / <sub>8</sub>	—	—	7 <sup>7</sup> / <sub>8</sub>	1 <sup>3</sup> / <sub>8</sub>	1 <sup>3</sup> / <sub>8</sub>	1 <sup>3</sup> / <sub>8</sub>	1 <sup>3</sup> / <sub>8</sub>	1 <sup>3</sup> / <sub>8</sub>
Distributor Nozzle Size*	G-3/G-2.5	G-3/G-2.5	E-8	E-8	C-17	C-17	—	—	G-4	C-12	E-12/E-10	E-12/E-10	E-12/E-10	E-12/E-10
<b>Intertwined Row Split Coils</b>														
No. of TXVs	2	2	2	2	2	2	—	—	2	2	2	2	4	4
Suction Connections (in. OD)	1 <sup>5</sup> / <sub>8</sub>	1 <sup>5</sup> / <sub>8</sub>	1 <sup>3</sup> / <sub>8</sub>	1 <sup>3</sup> / <sub>8</sub>	1 <sup>5</sup> / <sub>8</sub>	1 <sup>5</sup> / <sub>8</sub>	—	—	1 <sup>1</sup> / <sub>8</sub>	1 <sup>3</sup> / <sub>8</sub>	1 <sup>5</sup> / <sub>8</sub>	1 <sup>5</sup> / <sub>8</sub>	1 <sup>5</sup> / <sub>8</sub>	1 <sup>5</sup> / <sub>8</sub>
Distributor Connections (in. OD)	1 <sup>3</sup> / <sub>8</sub>	1 <sup>3</sup> / <sub>8</sub>	1 <sup>1</sup> / <sub>8</sub>	1 <sup>1</sup> / <sub>8</sub>	1 <sup>3</sup> / <sub>8</sub>	1 <sup>3</sup> / <sub>8</sub>	—	—	7 <sup>7</sup> / <sub>8</sub>	1 <sup>3</sup> / <sub>8</sub>	1 <sup>3</sup> / <sub>8</sub>	1 <sup>3</sup> / <sub>8</sub>	1 <sup>3</sup> / <sub>8</sub>	1 <sup>3</sup> / <sub>8</sub>
Distributor Nozzle Size*	G-3/G-2.5	G-3/G-2.5	E-8	E-8	C-17	C-17	—	—	G-4	C-12	E-12/E-10	E-12/E-10	E-12/E-10	E-12/E-10
<b>Single-Circuit Coils</b>														
No. of TXVs	1	1	—	—	—	—	—	—	1	—	—	—	—	—
Suction Connections (in. OD)	1 <sup>3</sup> / <sub>8</sub>	1 <sup>3</sup> / <sub>8</sub>	—	—	—	—	—	—	1 <sup>3</sup> / <sub>8</sub>	—	—	—	—	—
Distributor Connections (in. OD)	1 <sup>1</sup> / <sub>8</sub>	1 <sup>1</sup> / <sub>8</sub>	—	—	—	—	—	—	1 <sup>3</sup> / <sub>8</sub>	—	—	—	—	—
Distributor Nozzle Size*	E-8	E-8	—	—	—	—	—	—	C-12	—	—	—	—	—
<b>6-Row Coil</b>														
<b>Face Split Coils</b>														
No. of TXVs	—	—	2	2	2	2	—	—	2	2	2	2	4	4
Suction Connections (in. OD)	—	—	1 <sup>3</sup> / <sub>8</sub>	1 <sup>3</sup> / <sub>8</sub>	1 <sup>5</sup> / <sub>8</sub>	1 <sup>5</sup> / <sub>8</sub>	—	—	1 <sup>1</sup> / <sub>8</sub>	1 <sup>3</sup> / <sub>8</sub>	1 <sup>5</sup> / <sub>8</sub>	1 <sup>5</sup> / <sub>8</sub>	1 <sup>5</sup> / <sub>8</sub>	1 <sup>5</sup> / <sub>8</sub>
Distributor Connections (in. OD)	—	—	1 <sup>1</sup> / <sub>8</sub>	1 <sup>1</sup> / <sub>8</sub>	1 <sup>3</sup> / <sub>8</sub>	1 <sup>3</sup> / <sub>8</sub>	—	—	7 <sup>7</sup> / <sub>8</sub>	1 <sup>3</sup> / <sub>8</sub>	1 <sup>3</sup> / <sub>8</sub>	1 <sup>3</sup> / <sub>8</sub>	1 <sup>3</sup> / <sub>8</sub>	1 <sup>3</sup> / <sub>8</sub>
Distributor Nozzle Size*	—	—	E-8	E-8	C-17	C-17	—	—	G-4	C-12	E-12/E-10	E-12/E-10	E-12/E-10	E-12/E-10
<b>Intertwined Row Split Coils</b>														
No. of TXVs	—	—	2	2	2	2	—	—	2	2	2	2	4	4
Suction Connections (in. OD)	—	—	1 <sup>3</sup> / <sub>8</sub>	1 <sup>3</sup> / <sub>8</sub>	1 <sup>5</sup> / <sub>8</sub>	1 <sup>5</sup> / <sub>8</sub>	—	—	1 <sup>1</sup> / <sub>8</sub>	1 <sup>3</sup> / <sub>8</sub>	1 <sup>5</sup> / <sub>8</sub>	1 <sup>5</sup> / <sub>8</sub>	1 <sup>5</sup> / <sub>8</sub>	1 <sup>5</sup> / <sub>8</sub>
Distributor Connections (in. OD)	—	—	1 <sup>1</sup> / <sub>8</sub>	1 <sup>1</sup> / <sub>8</sub>	1 <sup>3</sup> / <sub>8</sub>	1 <sup>3</sup> / <sub>8</sub>	—	—	7 <sup>7</sup> / <sub>8</sub>	1 <sup>3</sup> / <sub>8</sub>	1 <sup>3</sup> / <sub>8</sub>	1 <sup>3</sup> / <sub>8</sub>	1 <sup>3</sup> / <sub>8</sub>	1 <sup>3</sup> / <sub>8</sub>
Distributor Nozzle Size*	—	—	E-8	E-8	C-17	C-17	—	—	G-4	C-12	E-12/E-10	E-12/E-10	E-12/E-10	E-12/E-10
<b>Single-Circuit Coils</b>														
No. of TXVs	—	—	—	—	—	—	—	—	1	—	—	—	—	—
Suction Connections (in. OD)	—	—	—	—	—	—	—	—	1 <sup>3</sup> / <sub>8</sub>	—	—	—	—	—
Distributor Connections (in. OD)	—	—	—	—	—	—	—	—	1 <sup>3</sup> / <sub>8</sub>	—	—	—	—	—
Distributor Nozzle Size	—	—	—	—	—	—	—	—	C-12	—	—	—	—	—
<b>8-Row Coil</b>														
<b>Face Split Coils</b>														
No. of TXVs	—	—	2	2	2	2	4	4	2	2	2	2	4	4
Suction Connections (in. OD)	—	—	1 <sup>3</sup> / <sub>8</sub>	1 <sup>3</sup> / <sub>8</sub>	1 <sup>5</sup> / <sub>8</sub>	1 <sup>5</sup> / <sub>8</sub>	1 <sup>5</sup> / <sub>8</sub>	1 <sup>5</sup> / <sub>8</sub>	1 <sup>1</sup> / <sub>8</sub>	1 <sup>3</sup> / <sub>8</sub>	1 <sup>5</sup> / <sub>8</sub>	1 <sup>5</sup> / <sub>8</sub>	1 <sup>5</sup> / <sub>8</sub>	1 <sup>5</sup> / <sub>8</sub>
Distributor Connections (in. OD)	—	—	1 <sup>1</sup> / <sub>8</sub>	1 <sup>1</sup> / <sub>8</sub>	1 <sup>3</sup> / <sub>8</sub>	1 <sup>3</sup> / <sub>8</sub>	1 <sup>3</sup> / <sub>8</sub>	1 <sup>3</sup> / <sub>8</sub>	7 <sup>7</sup> / <sub>8</sub>	1 <sup>3</sup> / <sub>8</sub>	1 <sup>3</sup> / <sub>8</sub>	1 <sup>3</sup> / <sub>8</sub>	1 <sup>3</sup> / <sub>8</sub>	1 <sup>3</sup> / <sub>8</sub>
Distributor Nozzle Size*	—	—	E-8	E-8	C-17	C-17	C-17	C-17	G-4	C-12	E-12/E-10	E-12/E-10	E-12/E-10	E-12/E-10
<b>Intertwined Row Split Coils</b>														
No. of TXVs	—	—	2	2	2	2	4	4	2	2	2	2	4	4
Suction Connections (in. OD)	—	—	1 <sup>3</sup> / <sub>8</sub>	1 <sup>3</sup> / <sub>8</sub>	1 <sup>5</sup> / <sub>8</sub>	1 <sup>5</sup> / <sub>8</sub>	1 <sup>5</sup> / <sub>8</sub>	1 <sup>5</sup> / <sub>8</sub>	1 <sup>1</sup> / <sub>8</sub>	1 <sup>3</sup> / <sub>8</sub>	1 <sup>5</sup> / <sub>8</sub>	1 <sup>5</sup> / <sub>8</sub>	1 <sup>5</sup> / <sub>8</sub>	1 <sup>5</sup> / <sub>8</sub>
Distributor Connections (in. OD)	—	—	1 <sup>1</sup> / <sub>8</sub>	1 <sup>1</sup> / <sub>8</sub>	1 <sup>3</sup> / <sub>8</sub>	1 <sup>3</sup> / <sub>8</sub>	1 <sup>3</sup> / <sub>8</sub>	1 <sup>3</sup> / <sub>8</sub>	7 <sup>7</sup> / <sub>8</sub>	1 <sup>3</sup> / <sub>8</sub>	1 <sup>3</sup> / <sub>8</sub>	1 <sup>3</sup> / <sub>8</sub>	1 <sup>3</sup> / <sub>8</sub>	1 <sup>3</sup> / <sub>8</sub>
Distributor Nozzle Size*	—	—	E-8	E-8	C-17	C-17	C-17	C-17	G-4	C-12	E-12/E-10	E-12/E-10	E-12/E-10	E-12/E-10
<b>Single-Circuit Coils</b>														
No. of TXVs	—	—	—	—	—	—	—	—	1	—	—	—	—	—
Suction Connections (in. OD)	—	—	—	—	—	—	—	—	1 <sup>3</sup> / <sub>8</sub>	—	—	—	—	—
Distributor Connections (in. OD)	—	—	—	—	—	—	—	—	1 <sup>3</sup> / <sub>8</sub>	—	—	—	—	—
Distributor Nozzle Size	—	—	—	—	—	—	—	—	C-12	—	—	—	—	—

LEGEND

TXV — Thermostatic Expansion Valve (Field Supplied)

\*When 2 nozzle sizes are listed, the smaller nozzle should be located on the upper distributor.

NOTE: Factory-supplied distributors have factory-selected nozzle sizes as shown. If necessary, replace factory-supplied nozzles with field-supplied and field-installed nozzles. Consult AHUBuilder® software selection program for correct nozzle selection.

# Physical data (cont)



## → DIRECT-EXPANSION CIRCUITING DATA (cont) MEDIUM FACE AREA COILS (cont)

CIRCUITING TYPE	39M UNIT SIZE			22T						25W		
	Half	Full	Double	Half		Full		Double		Half	Full	Double
Airflow (cfm) at 500 fpm	9,028			8,976						10,278		
Total Face Area (sq ft)	18.1			18.0						20.6		
				Upper	Lower	Upper	Lower	Upper	Lower			
Tubes in Face	32	32	32	44	44	44	44	44	44	32	32	32
Tube Length (in.)	65	65	65	47	47	47	47	47	47	72	72	72
No. of Circuits - Total	16	32	64	22	22	44	44	88	88	16	32	64
<b>4-Row Coil</b>												
<b>Face Split Coils</b>												
No. of TXVs	2	2	—	2	2	4	4	—	—	2	2	—
Suction Connections (in. OD)	1 <sup>1</sup> / <sub>8</sub>	1 <sup>5</sup> / <sub>8</sub>	—	1 <sup>3</sup> / <sub>8</sub>	1 <sup>3</sup> / <sub>8</sub>	1 <sup>3</sup> / <sub>8</sub>	1 <sup>3</sup> / <sub>8</sub>	—	—	1 <sup>1</sup> / <sub>8</sub>	1 <sup>5</sup> / <sub>8</sub>	—
Distributor Connections (in. OD)	7 <sup>7</sup> / <sub>8</sub>	1 <sup>3</sup> / <sub>8</sub>	—	1 <sup>1</sup> / <sub>8</sub>	1 <sup>1</sup> / <sub>8</sub>	1 <sup>1</sup> / <sub>8</sub>	1 <sup>1</sup> / <sub>8</sub>	—	—	7 <sup>7</sup> / <sub>8</sub>	1 <sup>3</sup> / <sub>8</sub>	—
Distributor Nozzle Size*	G-8	C-17	—	E-12	E-12	E-12	E-12	—	—	G-8	C-17	—
<b>Intertwined Row Split Coils</b>												
No. of TXVs	2	2	—	2	2	4	4	—	—	2	2	—
Suction Connections (in. OD)	1 <sup>1</sup> / <sub>8</sub>	1 <sup>5</sup> / <sub>8</sub>	—	1 <sup>3</sup> / <sub>8</sub>	1 <sup>3</sup> / <sub>8</sub>	1 <sup>3</sup> / <sub>8</sub>	1 <sup>3</sup> / <sub>8</sub>	—	—	1 <sup>1</sup> / <sub>8</sub>	1 <sup>5</sup> / <sub>8</sub>	—
Distributor Connections (in. OD)	7 <sup>7</sup> / <sub>8</sub>	1 <sup>3</sup> / <sub>8</sub>	—	1 <sup>1</sup> / <sub>8</sub>	1 <sup>1</sup> / <sub>8</sub>	1 <sup>1</sup> / <sub>8</sub>	1 <sup>1</sup> / <sub>8</sub>	—	—	7 <sup>7</sup> / <sub>8</sub>	1 <sup>3</sup> / <sub>8</sub>	—
Distributor Nozzle Size*	G-8	C-17	—	E-12	E-12	E-12	E-12	—	—	G-8	C-17	—
<b>Single-Circuit Coils</b>												
No. of TXVs	—	—	—	—	—	—	—	—	—	—	—	—
Suction Connections (in. OD)	—	—	—	—	—	—	—	—	—	—	—	—
Distributor Connections (in. OD)	—	—	—	—	—	—	—	—	—	—	—	—
Distributor Nozzle Size	—	—	—	—	—	—	—	—	—	—	—	—
<b>6-Row Coil</b>												
<b>Face Split Coils</b>												
No. of TXVs	2	2	—	2	2	4	4	—	—	2	2	—
Suction Connections (in. OD)	1 <sup>1</sup> / <sub>8</sub>	1 <sup>5</sup> / <sub>8</sub>	—	1 <sup>3</sup> / <sub>8</sub>	1 <sup>3</sup> / <sub>8</sub>	1 <sup>3</sup> / <sub>8</sub>	1 <sup>3</sup> / <sub>8</sub>	—	—	1 <sup>1</sup> / <sub>8</sub>	1 <sup>5</sup> / <sub>8</sub>	—
Distributor Connections (in. OD)	7 <sup>7</sup> / <sub>8</sub>	1 <sup>3</sup> / <sub>8</sub>	—	1 <sup>1</sup> / <sub>8</sub>	1 <sup>1</sup> / <sub>8</sub>	1 <sup>1</sup> / <sub>8</sub>	1 <sup>1</sup> / <sub>8</sub>	—	—	7 <sup>7</sup> / <sub>8</sub>	1 <sup>3</sup> / <sub>8</sub>	—
Distributor Nozzle Size*	G-8	C-17	—	E-12	E-12	E-12	E-12	—	—	G-8	C-17	—
<b>Intertwined Row Split Coils</b>												
No. of TXVs	2	2	—	2	2	4	4	—	—	2	2	—
Suction Connections (in. OD)	1 <sup>1</sup> / <sub>8</sub>	1 <sup>5</sup> / <sub>8</sub>	—	1 <sup>3</sup> / <sub>8</sub>	1 <sup>3</sup> / <sub>8</sub>	1 <sup>3</sup> / <sub>8</sub>	1 <sup>3</sup> / <sub>8</sub>	—	—	1 <sup>1</sup> / <sub>8</sub>	1 <sup>5</sup> / <sub>8</sub>	—
Distributor Connections (in. OD)	7 <sup>7</sup> / <sub>8</sub>	1 <sup>3</sup> / <sub>8</sub>	—	1 <sup>1</sup> / <sub>8</sub>	1 <sup>1</sup> / <sub>8</sub>	1 <sup>1</sup> / <sub>8</sub>	1 <sup>1</sup> / <sub>8</sub>	—	—	7 <sup>7</sup> / <sub>8</sub>	1 <sup>3</sup> / <sub>8</sub>	—
Distributor Nozzle Size*	G-8	C-17	—	E-12	E-12	E-12	E-12	—	—	G-8	C-17	—
<b>Single-Circuit Coils</b>												
No. of TXVs	—	—	—	—	—	—	—	—	—	—	—	—
Suction Connections (in. OD)	—	—	—	—	—	—	—	—	—	—	—	—
Distributor Connections (in. OD)	—	—	—	—	—	—	—	—	—	—	—	—
Distributor Nozzle Size	—	—	—	—	—	—	—	—	—	—	—	—
<b>8-Row Coil</b>												
<b>Face Split Coils</b>												
No. of TXVs	2	2	4	2	2	4	4	8	8	2	2	4
Suction Connections (in. OD)	1 <sup>1</sup> / <sub>8</sub>	1 <sup>5</sup> / <sub>8</sub>	1 <sup>5</sup> / <sub>8</sub>	1 <sup>3</sup> / <sub>8</sub>	1 <sup>3</sup> / <sub>8</sub>	1 <sup>3</sup> / <sub>8</sub>	1 <sup>3</sup> / <sub>8</sub>	1 <sup>3</sup> / <sub>8</sub>	1 <sup>3</sup> / <sub>8</sub>	1 <sup>1</sup> / <sub>8</sub>	1 <sup>5</sup> / <sub>8</sub>	1 <sup>5</sup> / <sub>8</sub>
Distributor Connections (in. OD)	7 <sup>7</sup> / <sub>8</sub>	1 <sup>3</sup> / <sub>8</sub>	1 <sup>3</sup> / <sub>8</sub>	1 <sup>1</sup> / <sub>8</sub>	1 <sup>1</sup> / <sub>8</sub>	1 <sup>1</sup> / <sub>8</sub>	1 <sup>1</sup> / <sub>8</sub>	1 <sup>1</sup> / <sub>8</sub>	1 <sup>1</sup> / <sub>8</sub>	7 <sup>7</sup> / <sub>8</sub>	1 <sup>3</sup> / <sub>8</sub>	1 <sup>3</sup> / <sub>8</sub>
Distributor Nozzle Size*	G-8	C-17	C-17	E-12	E-12	E-12	E-12	E-12	E-12	G-8	C-17	C-17
<b>Intertwined Row Split Coils</b>												
No. of TXVs	—	2	4	—	—	4	4	8	8	—	2	4
Suction Connections (in. OD)	—	1 <sup>5</sup> / <sub>8</sub>	1 <sup>5</sup> / <sub>8</sub>	—	—	1 <sup>3</sup> / <sub>8</sub>	1 <sup>3</sup> / <sub>8</sub>	1 <sup>3</sup> / <sub>8</sub>	1 <sup>3</sup> / <sub>8</sub>	—	1 <sup>5</sup> / <sub>8</sub>	1 <sup>5</sup> / <sub>8</sub>
Distributor Connections (in. OD)	—	1 <sup>3</sup> / <sub>8</sub>	1 <sup>3</sup> / <sub>8</sub>	—	—	1 <sup>1</sup> / <sub>8</sub>	1 <sup>1</sup> / <sub>8</sub>	1 <sup>1</sup> / <sub>8</sub>	1 <sup>1</sup> / <sub>8</sub>	—	1 <sup>3</sup> / <sub>8</sub>	1 <sup>3</sup> / <sub>8</sub>
Distributor Nozzle Size*	—	C-17	C-17	—	—	E-12	E-12	E-12	E-12	—	C-17	C-17
<b>Single-Circuit Coils</b>												
No. of TXVs	—	—	—	—	—	—	—	—	—	—	—	—
Suction Connections (in. OD)	—	—	—	—	—	—	—	—	—	—	—	—
Distributor Connections (in. OD)	—	—	—	—	—	—	—	—	—	—	—	—
Distributor Nozzle Size	—	—	—	—	—	—	—	—	—	—	—	—

**LEGEND**

**TXV** — Thermostatic Expansion Valve (Field Supplied)

\*When 2 nozzle sizes are listed, the smaller nozzle should be located on the upper distributor.

NOTE: Factory-supplied distributors have factory-selected nozzle sizes as shown. If necessary, replace factory-supplied nozzles with field-supplied and field-installed nozzles. Consult **AHUBuilder**® software selection program for correct nozzle selection.



→ **DIRECT-EXPANSION CIRCUITING DATA (cont)**  
**MEDIUM FACE AREA COILS (cont)**

39M UNIT SIZE	25T						30W			30T					
	Half		Full		Double		Half	Full	Double	Half		Full		Double	
Airflow (cfm) at 500 fpm	9,358						15,174			11,267					
Total Face Area (sq ft)	18.7						30.3			22.5					
	Upper	Lower	Upper	Lower	Upper	Lower				Upper	Lower	Upper	Lower	Upper	Lower
Tubes in Face	44	44	44	44	44	44	38	38	38	44	44	44	44	44	44
Tube Length (in.)	49	49	49	49	49	49	92	92	92	59	59	59	59	59	59
No. of Circuits - Total	22	22	44	44	88	88	19	38	76	22	22	44	44	88	88
<b>4-Row Coil</b>															
<b>Face Split Coils</b>															
No. of TXVs	2	2	4	4	—	—	2	2	—	2	2	4	4	—	—
Suction Connections (in. OD)	1 <sup>3</sup> / <sub>8</sub>	1 <sup>3</sup> / <sub>8</sub>	1 <sup>3</sup> / <sub>8</sub>	1 <sup>3</sup> / <sub>8</sub>	—	—	1 <sup>3</sup> / <sub>8</sub>	1 <sup>3</sup> / <sub>8</sub>	—	1 <sup>3</sup> / <sub>8</sub>	1 <sup>3</sup> / <sub>8</sub>	1 <sup>3</sup> / <sub>8</sub>	1 <sup>3</sup> / <sub>8</sub>	—	—
Distributor Connections (in. OD)	1 <sup>1</sup> / <sub>8</sub>	1 <sup>1</sup> / <sub>8</sub>	1 <sup>1</sup> / <sub>8</sub>	1 <sup>1</sup> / <sub>8</sub>	—	—	1 <sup>1</sup> / <sub>8</sub>	1 <sup>3</sup> / <sub>8</sub>	—	1 <sup>1</sup> / <sub>8</sub>	1 <sup>1</sup> / <sub>8</sub>	1 <sup>1</sup> / <sub>8</sub>	1 <sup>1</sup> / <sub>8</sub>	—	—
Distributor Nozzle Size*	E-12	E-12	E-12	E-12	—	—	E-10/E-8	C-20	—	E-12	E-12	E-12	E-12	—	—
<b>Intertwined Row Split Coils</b>															
No. of TXVs	2	2	4	4	—	—	2	2	—	2	2	4	4	—	—
Suction Connections (in. OD)	1 <sup>3</sup> / <sub>8</sub>	1 <sup>3</sup> / <sub>8</sub>	1 <sup>3</sup> / <sub>8</sub>	1 <sup>3</sup> / <sub>8</sub>	—	—	1 <sup>3</sup> / <sub>8</sub>	1 <sup>5</sup> / <sub>8</sub>	—	1 <sup>3</sup> / <sub>8</sub>	1 <sup>3</sup> / <sub>8</sub>	1 <sup>3</sup> / <sub>8</sub>	1 <sup>3</sup> / <sub>8</sub>	—	—
Distributor Connections (in. OD)	1 <sup>1</sup> / <sub>8</sub>	1 <sup>1</sup> / <sub>8</sub>	1 <sup>1</sup> / <sub>8</sub>	1 <sup>1</sup> / <sub>8</sub>	—	—	1 <sup>1</sup> / <sub>8</sub>	1 <sup>3</sup> / <sub>8</sub>	—	1 <sup>1</sup> / <sub>8</sub>	1 <sup>1</sup> / <sub>8</sub>	1 <sup>1</sup> / <sub>8</sub>	1 <sup>1</sup> / <sub>8</sub>	—	—
Distributor Nozzle Size*	E-12	E-12	E-12	E-12	—	—	E-10/E-8	C-20	—	E-12	E-12	E-12	E-12	—	—
<b>Single-Circuit Coils</b>															
No. of TXVs	—	—	—	—	—	—	—	—	—	—	—	—	—	—	—
Suction Connections (in. OD)	—	—	—	—	—	—	—	—	—	—	—	—	—	—	—
Distributor Connections (in. OD)	—	—	—	—	—	—	—	—	—	—	—	—	—	—	—
Distributor Nozzle Size	—	—	—	—	—	—	—	—	—	—	—	—	—	—	—
<b>6-Row Coil</b>															
<b>Face Split Coils</b>															
No. of TXVs	2	2	4	4	—	—	2	2	—	2	2	4	4	—	—
Suction Connections (in. OD)	1 <sup>3</sup> / <sub>8</sub>	1 <sup>3</sup> / <sub>8</sub>	1 <sup>3</sup> / <sub>8</sub>	1 <sup>3</sup> / <sub>8</sub>	—	—	1 <sup>3</sup> / <sub>8</sub>	1 <sup>5</sup> / <sub>8</sub>	—	1 <sup>3</sup> / <sub>8</sub>	1 <sup>3</sup> / <sub>8</sub>	1 <sup>3</sup> / <sub>8</sub>	1 <sup>3</sup> / <sub>8</sub>	—	—
Distributor Connections (in. OD)	1 <sup>1</sup> / <sub>8</sub>	1 <sup>1</sup> / <sub>8</sub>	1 <sup>1</sup> / <sub>8</sub>	1 <sup>1</sup> / <sub>8</sub>	—	—	1 <sup>1</sup> / <sub>8</sub>	1 <sup>3</sup> / <sub>8</sub>	—	1 <sup>1</sup> / <sub>8</sub>	1 <sup>1</sup> / <sub>8</sub>	1 <sup>1</sup> / <sub>8</sub>	1 <sup>1</sup> / <sub>8</sub>	—	—
Distributor Nozzle Size*	E-12	E-12	E-12	E-12	—	—	E-10/E-8	C-20	—	E-12	E-12	E-12	E-12	—	—
<b>Intertwined Row Split Coils</b>															
No. of TXVs	2	2	4	4	—	—	2	2	—	2	2	4	4	—	—
Suction Connections (in. OD)	1 <sup>3</sup> / <sub>8</sub>	1 <sup>3</sup> / <sub>8</sub>	1 <sup>3</sup> / <sub>8</sub>	1 <sup>3</sup> / <sub>8</sub>	—	—	1 <sup>3</sup> / <sub>8</sub>	1 <sup>5</sup> / <sub>8</sub>	—	1 <sup>3</sup> / <sub>8</sub>	1 <sup>3</sup> / <sub>8</sub>	1 <sup>3</sup> / <sub>8</sub>	1 <sup>3</sup> / <sub>8</sub>	—	—
Distributor Connections (in. OD)	1 <sup>1</sup> / <sub>8</sub>	1 <sup>1</sup> / <sub>8</sub>	1 <sup>1</sup> / <sub>8</sub>	1 <sup>1</sup> / <sub>8</sub>	—	—	1 <sup>1</sup> / <sub>8</sub>	1 <sup>3</sup> / <sub>8</sub>	—	1 <sup>1</sup> / <sub>8</sub>	1 <sup>1</sup> / <sub>8</sub>	1 <sup>1</sup> / <sub>8</sub>	1 <sup>1</sup> / <sub>8</sub>	—	—
Distributor Nozzle Size*	E-12	E-12	E-12	E-12	—	—	E-10/E-8	C-20	—	E-12	E-12	E-12	E-12	—	—
<b>Single-Circuit Coils</b>															
No. of TXVs	—	—	—	—	—	—	—	—	—	—	—	—	—	—	—
Suction Connections (in. OD)	—	—	—	—	—	—	—	—	—	—	—	—	—	—	—
Distributor Connections (in. OD)	—	—	—	—	—	—	—	—	—	—	—	—	—	—	—
Distributor Nozzle Size	—	—	—	—	—	—	—	—	—	—	—	—	—	—	—
<b>8-Row Coil</b>															
<b>Face Split Coils</b>															
No. of TXVs	2	2	4	4	8	8	2	2	4	2	2	4	4	8	8
Suction Connections (in. OD)	1 <sup>3</sup> / <sub>8</sub>	1 <sup>3</sup> / <sub>8</sub>	1 <sup>3</sup> / <sub>8</sub>	1 <sup>3</sup> / <sub>8</sub>	1 <sup>3</sup> / <sub>8</sub>	1 <sup>3</sup> / <sub>8</sub>	1 <sup>3</sup> / <sub>8</sub>	1 <sup>5</sup> / <sub>8</sub>	1 <sup>5</sup> / <sub>8</sub>	1 <sup>3</sup> / <sub>8</sub>	1 <sup>3</sup> / <sub>8</sub>	1 <sup>3</sup> / <sub>8</sub>	1 <sup>3</sup> / <sub>8</sub>	1 <sup>3</sup> / <sub>8</sub>	1 <sup>3</sup> / <sub>8</sub>
Distributor Connections (in. OD)	1 <sup>1</sup> / <sub>8</sub>	1 <sup>1</sup> / <sub>8</sub>	1 <sup>1</sup> / <sub>8</sub>	1 <sup>1</sup> / <sub>8</sub>	1 <sup>1</sup> / <sub>8</sub>	1 <sup>1</sup> / <sub>8</sub>	1 <sup>1</sup> / <sub>8</sub>	1 <sup>3</sup> / <sub>8</sub>	1 <sup>3</sup> / <sub>8</sub>	1 <sup>1</sup> / <sub>8</sub>	1 <sup>1</sup> / <sub>8</sub>	1 <sup>1</sup> / <sub>8</sub>	1 <sup>1</sup> / <sub>8</sub>	1 <sup>1</sup> / <sub>8</sub>	1 <sup>1</sup> / <sub>8</sub>
Distributor Nozzle Size*	E-12	E-12	E-12	E-12	E-12	E-12	E-10/E-8	C-20	C-20	E-12	E-12	E-12	E-12	E-12	E-12
<b>Intertwined Row Split Coils</b>															
No. of TXVs	—	—	4	4	8	8	2	2	2	—	—	4	4	8	8
Suction Connections (in. OD)	—	—	1 <sup>3</sup> / <sub>8</sub>	1 <sup>3</sup> / <sub>8</sub>	1 <sup>3</sup> / <sub>8</sub>	1 <sup>3</sup> / <sub>8</sub>	1 <sup>3</sup> / <sub>8</sub>	1 <sup>5</sup> / <sub>8</sub>	1 <sup>5</sup> / <sub>8</sub>	—	—	1 <sup>3</sup> / <sub>8</sub>	1 <sup>3</sup> / <sub>8</sub>	1 <sup>3</sup> / <sub>8</sub>	1 <sup>3</sup> / <sub>8</sub>
Distributor Connections (in. OD)	—	—	1 <sup>1</sup> / <sub>8</sub>	1 <sup>1</sup> / <sub>8</sub>	1 <sup>1</sup> / <sub>8</sub>	1 <sup>1</sup> / <sub>8</sub>	1 <sup>1</sup> / <sub>8</sub>	1 <sup>3</sup> / <sub>8</sub>	1 <sup>3</sup> / <sub>8</sub>	—	—	1 <sup>1</sup> / <sub>8</sub>	1 <sup>1</sup> / <sub>8</sub>	1 <sup>1</sup> / <sub>8</sub>	1 <sup>1</sup> / <sub>8</sub>
Distributor Nozzle Size*	—	—	E-12	E-12	E-12	E-12	E-10/E-8	C-20	C-20	—	—	E-12	E-12	E-12	E-12
<b>Single-Circuit Coils</b>															
No. of TXVs	—	—	—	—	—	—	—	—	—	—	—	—	—	—	—
Suction Connections (in. OD)	—	—	—	—	—	—	—	—	—	—	—	—	—	—	—
Distributor Connections (in. OD)	—	—	—	—	—	—	—	—	—	—	—	—	—	—	—
Distributor Nozzle Size	—	—	—	—	—	—	—	—	—	—	—	—	—	—	—

**LEGEND**

**TXV** — Thermostatic Expansion Valve (Field Supplied)

\*When 2 nozzle sizes are listed, the smaller nozzle should be located on the upper distributor.

NOTE: Factory-supplied distributors have factory-selected nozzle sizes as shown. If necessary, replace factory-supplied nozzles with field-supplied and field-installed nozzles. Consult **AHUBuilder®** software selection program for correct nozzle selection.

# Physical data (cont)



## → DIRECT-EXPANSION CIRCUITING DATA (cont) MEDIUM FACE AREA COILS (cont)

CIRCUITING TYPE	39M UNIT SIZE		35T				36W		37T					
	Half		Full		Double		Full	Double	Half		Full		Double	
Airflow (cfm) at 500 fpm			13,958				15,000		15,365					
Total Face Area (sq ft)			27.9				30.0		37.9					
	Upper	Lower	Upper	Lower	Upper	Lower			Upper	Lower	Upper	Lower	Upper	Lower
Tubes in Face	24	24	24	24	24	24	36	36	30	30	30	30	30	30
Tube Length (in.)	67	67	67	67	67	67	96	96	59	59	59	59	59	59
No. of Circuits - Total	12	12	24	24	48	48	36	72	15	15	30	30	60	60
<b>4-Row Coil</b>														
<b>Face Split Coils</b>														
No. of TXVs	2	2	2	2	—	—	2	—	2	2	2	2	—	—
Suction Connections (in. OD)	1 <sup>1</sup> / <sub>8</sub>	1 <sup>1</sup> / <sub>8</sub>	1 <sup>3</sup> / <sub>8</sub>	1 <sup>3</sup> / <sub>8</sub>	—	—	1 <sup>5</sup> / <sub>8</sub>	—	1 <sup>1</sup> / <sub>8</sub>	1 <sup>1</sup> / <sub>8</sub>	1 <sup>3</sup> / <sub>8</sub>	1 <sup>5</sup> / <sub>8</sub>	—	—
Distributor Connections (in. OD)	7 <sup>7</sup> / <sub>8</sub>	7 <sup>7</sup> / <sub>8</sub>	1 <sup>3</sup> / <sub>8</sub>	1 <sup>3</sup> / <sub>8</sub>	—	—	1 <sup>3</sup> / <sub>8</sub>	—	7 <sup>7</sup> / <sub>8</sub>	7 <sup>7</sup> / <sub>8</sub>	1 <sup>3</sup> / <sub>8</sub>	1 <sup>3</sup> / <sub>8</sub>	—	—
Distributor Nozzle Size*	G-4	G-4	C-12	C-12	—	—	C-17	—	G-8/G-6	G-8/G-6	C-15	C-15	—	—
<b>Intertwined Row Split Coils</b>														
No. of TXVs	2	2	2	2	—	—	2	—	2	2	2	2	—	—
Suction Connections (in. OD)	1 <sup>1</sup> / <sub>8</sub>	1 <sup>1</sup> / <sub>8</sub>	1 <sup>3</sup> / <sub>8</sub>	1 <sup>3</sup> / <sub>8</sub>	—	—	1 <sup>5</sup> / <sub>8</sub>	—	1 <sup>1</sup> / <sub>8</sub>	1 <sup>1</sup> / <sub>8</sub>	1 <sup>3</sup> / <sub>8</sub>	1 <sup>5</sup> / <sub>8</sub>	—	—
Distributor Connections (in. OD)	7 <sup>7</sup> / <sub>8</sub>	7 <sup>7</sup> / <sub>8</sub>	1 <sup>3</sup> / <sub>8</sub>	1 <sup>5</sup> / <sub>8</sub>	—	—	1 <sup>3</sup> / <sub>8</sub>	—	7 <sup>7</sup> / <sub>8</sub>	7 <sup>7</sup> / <sub>8</sub>	1 <sup>3</sup> / <sub>8</sub>	1 <sup>3</sup> / <sub>8</sub>	—	—
Distributor Nozzle Size*	G-4	G-4	C-12	C-12	—	—	C-17	—	G-8/G-6	G-8/G-6	C-15	C-15	—	—
<b>Single-Circuit Coils</b>														
No. of TXVs	—	—	—	—	—	—	—	—	—	—	—	—	—	—
Suction Connections (in. OD)	—	—	—	—	—	—	—	—	—	—	—	—	—	—
Distributor Connections (in. OD)	—	—	—	—	—	—	—	—	—	—	—	—	—	—
Distributor Nozzle Size	—	—	—	—	—	—	—	—	—	—	—	—	—	—
<b>6-Row Coil</b>														
<b>Face Split Coils</b>														
No. of TXVs	2	2	2	2	—	—	2	—	2	2	2	2	—	—
Suction Connections (in. OD)	1 <sup>1</sup> / <sub>8</sub>	1 <sup>1</sup> / <sub>8</sub>	1 <sup>3</sup> / <sub>8</sub>	1 <sup>3</sup> / <sub>8</sub>	—	—	1 <sup>5</sup> / <sub>8</sub>	—	1 <sup>1</sup> / <sub>8</sub>	1 <sup>1</sup> / <sub>8</sub>	1 <sup>5</sup> / <sub>8</sub>	1 <sup>5</sup> / <sub>8</sub>	—	—
Distributor Connections (in. OD)	7 <sup>7</sup> / <sub>8</sub>	7 <sup>7</sup> / <sub>8</sub>	1 <sup>3</sup> / <sub>8</sub>	1 <sup>3</sup> / <sub>8</sub>	—	—	1 <sup>3</sup> / <sub>8</sub>	—	7 <sup>7</sup> / <sub>8</sub>	7 <sup>7</sup> / <sub>8</sub>	1 <sup>3</sup> / <sub>8</sub>	1 <sup>3</sup> / <sub>8</sub>	—	—
Distributor Nozzle Size*	G-4	G-4	C-12	C-12	—	—	C-17	—	G-8/G-6	G-8/G-6	C-15	C-15	—	—
<b>Intertwined Row Split Coils</b>														
No. of TXVs	2	2	2	2	—	—	2	—	2	2	2	2	—	—
Suction Connections (in. OD)	1 <sup>1</sup> / <sub>8</sub>	1 <sup>1</sup> / <sub>8</sub>	1 <sup>3</sup> / <sub>8</sub>	1 <sup>3</sup> / <sub>8</sub>	—	—	1 <sup>5</sup> / <sub>8</sub>	—	1 <sup>1</sup> / <sub>8</sub>	1 <sup>1</sup> / <sub>8</sub>	1 <sup>3</sup> / <sub>8</sub>	1 <sup>5</sup> / <sub>8</sub>	—	—
Distributor Connections (in. OD)	7 <sup>7</sup> / <sub>8</sub>	7 <sup>7</sup> / <sub>8</sub>	1 <sup>3</sup> / <sub>8</sub>	1 <sup>5</sup> / <sub>8</sub>	—	—	1 <sup>3</sup> / <sub>8</sub>	—	7 <sup>7</sup> / <sub>8</sub>	7 <sup>7</sup> / <sub>8</sub>	1 <sup>3</sup> / <sub>8</sub>	1 <sup>3</sup> / <sub>8</sub>	—	—
Distributor Nozzle Size*	G-4	G-4	C-12	C-12	—	—	C-17	—	G-8/G-6	G-8/G-6	C-15	C-15	—	—
<b>Single-Circuit Coils</b>														
No. of TXVs	—	—	—	—	—	—	—	—	—	—	—	—	—	—
Suction Connections (in. OD)	—	—	—	—	—	—	—	—	—	—	—	—	—	—
Distributor Connections (in. OD)	—	—	—	—	—	—	—	—	—	—	—	—	—	—
Distributor Nozzle Size	—	—	—	—	—	—	—	—	—	—	—	—	—	—
<b>8-Row Coil</b>														
<b>Face Split Coils</b>														
No. of TXVs	2	2	2	2	4	4	2	4	2	2	2	2	4	4
Suction Connections (in. OD)	1 <sup>1</sup> / <sub>8</sub>	1 <sup>1</sup> / <sub>8</sub>	1 <sup>3</sup> / <sub>8</sub>	1 <sup>3</sup> / <sub>8</sub>	1 <sup>3</sup> / <sub>8</sub>	1 <sup>3</sup> / <sub>8</sub>	1 <sup>5</sup> / <sub>8</sub>	1 <sup>5</sup> / <sub>8</sub>	1 <sup>1</sup> / <sub>8</sub>	1 <sup>1</sup> / <sub>8</sub>	1 <sup>5</sup> / <sub>8</sub>	1 <sup>5</sup> / <sub>8</sub>	1 <sup>5</sup> / <sub>8</sub>	1 <sup>5</sup> / <sub>8</sub>
Distributor Connections (in. OD)	7 <sup>7</sup> / <sub>8</sub>	7 <sup>7</sup> / <sub>8</sub>	1 <sup>3</sup> / <sub>8</sub>	1 <sup>3</sup> / <sub>8</sub>	1 <sup>3</sup> / <sub>8</sub>	1 <sup>3</sup> / <sub>8</sub>	1 <sup>3</sup> / <sub>8</sub>	1 <sup>3</sup> / <sub>8</sub>	7 <sup>7</sup> / <sub>8</sub>	7 <sup>7</sup> / <sub>8</sub>	1 <sup>3</sup> / <sub>8</sub>	1 <sup>3</sup> / <sub>8</sub>	1 <sup>3</sup> / <sub>8</sub>	1 <sup>3</sup> / <sub>8</sub>
Distributor Nozzle Size*	G-4	G-4	C-12	C-12	C-12	C-12	C-17	C-17	G-8/G-6	G-8/G-6	C-15	C-15	C-15	C-15
<b>Intertwined Row Split Coils</b>														
No. of TXVs	2	2	2	2	4	4	2	4	2	2	2	2	4	4
Suction Connections (in. OD)	1 <sup>1</sup> / <sub>8</sub>	1 <sup>1</sup> / <sub>8</sub>	1 <sup>3</sup> / <sub>8</sub>	1 <sup>3</sup> / <sub>8</sub>	1 <sup>3</sup> / <sub>8</sub>	1 <sup>3</sup> / <sub>8</sub>	1 <sup>5</sup> / <sub>8</sub>	1 <sup>5</sup> / <sub>8</sub>	1 <sup>1</sup> / <sub>8</sub>	1 <sup>1</sup> / <sub>8</sub>	1 <sup>5</sup> / <sub>8</sub>	1 <sup>5</sup> / <sub>8</sub>	1 <sup>5</sup> / <sub>8</sub>	1 <sup>5</sup> / <sub>8</sub>
Distributor Connections (in. OD)	7 <sup>7</sup> / <sub>8</sub>	7 <sup>7</sup> / <sub>8</sub>	1 <sup>3</sup> / <sub>8</sub>	1 <sup>5</sup> / <sub>8</sub>	1 <sup>3</sup> / <sub>8</sub>	1 <sup>3</sup> / <sub>8</sub>	1 <sup>3</sup> / <sub>8</sub>	1 <sup>3</sup> / <sub>8</sub>	7 <sup>7</sup> / <sub>8</sub>	7 <sup>7</sup> / <sub>8</sub>	1 <sup>3</sup> / <sub>8</sub>	1 <sup>3</sup> / <sub>8</sub>	1 <sup>3</sup> / <sub>8</sub>	1 <sup>3</sup> / <sub>8</sub>
Distributor Nozzle Size*	G-4	G-4	C-12	C-12	C-12	C-12	C-17	C-17	G-8/G-6	G-8/G-6	C-15	C-15	C-15	C-15
<b>Single-Circuit Coils</b>														
No. of TXVs	—	—	—	—	—	—	—	—	—	—	—	—	—	—
Suction Connections (in. OD)	—	—	—	—	—	—	—	—	—	—	—	—	—	—
Distributor Connections (in. OD)	—	—	—	—	—	—	—	—	—	—	—	—	—	—
Distributor Nozzle Size	—	—	—	—	—	—	—	—	—	—	—	—	—	—

**LEGEND**

TXV — Thermostatic Expansion Valve (Field Supplied)

\*When 2 nozzle sizes are listed, the smaller nozzle should be located on the upper distributor.

NOTE: Factory-supplied distributors have factory-selected nozzle sizes as shown. If necessary, replace factory-supplied nozzles with field-supplied and field-installed nozzles. Consult AHUBuilder® software selection program for correct nozzle selection.

**DIRECT-EXPANSION CIRCUITING DATA (cont)**  
**MEDIUM FACE AREA COILS (cont)**

39M UNIT SIZE	40W		50W		61W				72W			
	Full	Double	Full	Double	Full		Double		Full		Double	
<b>CIRCUITING TYPE</b>	18,333		19,861		25,278				29,722			
<b>Airflow (cfm) at 500 fpm</b>	36.7		39.7		50.6				59.4			
<b>Total Face Area (sq ft)</b>	44		44		28	28	28	28	32	32	32	32
<b> Tubes in Face</b>	44	44	44	44	104	104	104	104	107	107	107	107
<b> Tube Length (in.)</b>	60	60	104	104	28	28	56	56	32	32	60	64
<b> No. of Circuits - Total</b>	44	88	44	88	28	28	56	56	32	32	60	64
<b>4-Row Coil</b>					Upper	Lower	Upper	Lower	Upper	Lower	Upper	Lower
<b>Face Split Coils</b>												
<b>No. of TXVs</b>	4	—	4	—	2	2	—	—	2	2	—	—
<b>Suction Connections (in. OD)</b>	1 <sup>3</sup> / <sub>8</sub>	—	1 <sup>3</sup> / <sub>8</sub>	—	1 <sup>5</sup> / <sub>8</sub>	1 <sup>5</sup> / <sub>8</sub>	—	—	1 <sup>5</sup> / <sub>8</sub>	1 <sup>5</sup> / <sub>8</sub>	—	—
<b>Distributor Connections (in. OD)</b>	1 <sup>1</sup> / <sub>8</sub>	—	1 <sup>1</sup> / <sub>8</sub>	—	1 <sup>3</sup> / <sub>8</sub>	1 <sup>3</sup> / <sub>8</sub>	—	—	1 <sup>3</sup> / <sub>8</sub>	1 <sup>3</sup> / <sub>8</sub>	—	—
<b>Distributor Nozzle Size*</b>	E-12	—	E-12	—	C-15	C-15	—	—	C-17	C-17	—	—
<b>Intertwined Row Split Coils</b>												
<b>No. of TXVs</b>	4	—	4	—	2	2	—	—	2	2	—	—
<b>Suction Connections (in. OD)</b>	1 <sup>3</sup> / <sub>8</sub>	—	1 <sup>3</sup> / <sub>8</sub>	—	1 <sup>5</sup> / <sub>8</sub>	1 <sup>5</sup> / <sub>8</sub>	—	—	1 <sup>5</sup> / <sub>8</sub>	1 <sup>5</sup> / <sub>8</sub>	—	—
<b>Distributor Connections (in. OD)</b>	1 <sup>1</sup> / <sub>8</sub>	—	1 <sup>1</sup> / <sub>8</sub>	—	1 <sup>3</sup> / <sub>8</sub>	1 <sup>3</sup> / <sub>8</sub>	—	—	1 <sup>3</sup> / <sub>8</sub>	1 <sup>3</sup> / <sub>8</sub>	—	—
<b>Distributor Nozzle Size*</b>	E-12	—	E-12	—	C-15	C-15	—	—	C-17	C-17	—	—
<b>Single-Circuit Coils</b>												
<b>No. of TXVs</b>	—	—	—	—	—	—	—	—	—	—	—	—
<b>Suction Connections (in. OD)</b>	—	—	—	—	—	—	—	—	—	—	—	—
<b>Distributor Connections (in. OD)</b>	—	—	—	—	—	—	—	—	—	—	—	—
<b>Distributor Nozzle Size</b>	—	—	—	—	—	—	—	—	—	—	—	—
<b>6-Row Coil</b>												
<b>Face Split Coils</b>												
<b>No. of TXVs</b>	4	—	4	—	2	2	—	—	2	2	—	—
<b>Suction Connections (in. OD)</b>	1 <sup>3</sup> / <sub>8</sub>	—	1 <sup>3</sup> / <sub>8</sub>	—	1 <sup>5</sup> / <sub>8</sub>	1 <sup>5</sup> / <sub>8</sub>	—	—	1 <sup>5</sup> / <sub>8</sub>	1 <sup>5</sup> / <sub>8</sub>	—	—
<b>Distributor Connections (in. OD)</b>	1 <sup>1</sup> / <sub>8</sub>	—	1 <sup>1</sup> / <sub>8</sub>	—	1 <sup>3</sup> / <sub>8</sub>	1 <sup>3</sup> / <sub>8</sub>	—	—	1 <sup>3</sup> / <sub>8</sub>	1 <sup>3</sup> / <sub>8</sub>	—	—
<b>Distributor Nozzle Size*</b>	E-12	—	E-12	—	C-15	C-15	—	—	C-17	C-17	—	—
<b>Intertwined Row Split Coils</b>												
<b>No. of TXVs</b>	4	—	4	—	2	2	—	—	2	2	—	—
<b>Suction Connections (in. OD)</b>	1 <sup>3</sup> / <sub>8</sub>	—	1 <sup>3</sup> / <sub>8</sub>	—	1 <sup>5</sup> / <sub>8</sub>	1 <sup>5</sup> / <sub>8</sub>	—	—	1 <sup>5</sup> / <sub>8</sub>	1 <sup>5</sup> / <sub>8</sub>	—	—
<b>Distributor Connections (in. OD)</b>	1 <sup>1</sup> / <sub>8</sub>	—	1 <sup>1</sup> / <sub>8</sub>	—	1 <sup>3</sup> / <sub>8</sub>	1 <sup>3</sup> / <sub>8</sub>	—	—	1 <sup>3</sup> / <sub>8</sub>	1 <sup>3</sup> / <sub>8</sub>	—	—
<b>Distributor Nozzle Size*</b>	E-12	—	E-12	—	C-15	C-15	—	—	C-17	C-17	—	—
<b>Single-Circuit Coils</b>												
<b>No. of TXVs</b>	—	—	—	—	—	—	—	—	—	—	—	—
<b>Suction Connections (in. OD)</b>	—	—	—	—	—	—	—	—	—	—	—	—
<b>Distributor Connections (in. OD)</b>	—	—	—	—	—	—	—	—	—	—	—	—
<b>Distributor Nozzle Size</b>	—	—	—	—	—	—	—	—	—	—	—	—
<b>8-Row Coil</b>												
<b>Face Split Coils</b>												
<b>No. of TXVs</b>	4	8	4	8	2	2	4	4	2	2	4	4
<b>Suction Connections (in. OD)</b>	1 <sup>3</sup> / <sub>8</sub>	1 <sup>3</sup> / <sub>8</sub>	1 <sup>3</sup> / <sub>8</sub>	1 <sup>3</sup> / <sub>8</sub>	1 <sup>5</sup> / <sub>8</sub>	1 <sup>5</sup> / <sub>8</sub>	1 <sup>5</sup> / <sub>8</sub>	1 <sup>5</sup> / <sub>8</sub>	1 <sup>5</sup> / <sub>8</sub>	1 <sup>5</sup> / <sub>8</sub>	1 <sup>5</sup> / <sub>8</sub>	1 <sup>5</sup> / <sub>8</sub>
<b>Distributor Connections (in. OD)</b>	1 <sup>1</sup> / <sub>8</sub>	1 <sup>1</sup> / <sub>8</sub>	1 <sup>1</sup> / <sub>8</sub>	1 <sup>1</sup> / <sub>8</sub>	1 <sup>3</sup> / <sub>8</sub>	1 <sup>3</sup> / <sub>8</sub>	1 <sup>3</sup> / <sub>8</sub>	1 <sup>3</sup> / <sub>8</sub>	1 <sup>3</sup> / <sub>8</sub>	1 <sup>3</sup> / <sub>8</sub>	1 <sup>3</sup> / <sub>8</sub>	1 <sup>3</sup> / <sub>8</sub>
<b>Distributor Nozzle Size*</b>	E-12	E-12	E-12	E-12	C-15	C-15	C-15	C-15	C-17	C-17	C-17	C-17
<b>Intertwined Row Split Coils</b>												
<b>No. of TXVs</b>	4	8	4	8	2	2	4	4	2	2	4	4
<b>Suction Connections (in. OD)</b>	1 <sup>3</sup> / <sub>8</sub>	1 <sup>3</sup> / <sub>8</sub>	1 <sup>3</sup> / <sub>8</sub>	1 <sup>3</sup> / <sub>8</sub>	1 <sup>5</sup> / <sub>8</sub>	1 <sup>5</sup> / <sub>8</sub>	1 <sup>5</sup> / <sub>8</sub>	1 <sup>5</sup> / <sub>8</sub>	1 <sup>5</sup> / <sub>8</sub>	1 <sup>5</sup> / <sub>8</sub>	1 <sup>5</sup> / <sub>8</sub>	1 <sup>5</sup> / <sub>8</sub>
<b>Distributor Connections (in. OD)</b>	1 <sup>1</sup> / <sub>8</sub>	1 <sup>1</sup> / <sub>8</sub>	1 <sup>1</sup> / <sub>8</sub>	1 <sup>1</sup> / <sub>8</sub>	1 <sup>3</sup> / <sub>8</sub>	1 <sup>3</sup> / <sub>8</sub>	1 <sup>3</sup> / <sub>8</sub>	1 <sup>3</sup> / <sub>8</sub>	1 <sup>3</sup> / <sub>8</sub>	1 <sup>3</sup> / <sub>8</sub>	1 <sup>3</sup> / <sub>8</sub>	1 <sup>3</sup> / <sub>8</sub>
<b>Distributor Nozzle Size*</b>	E-12	E-12	E-12	E-12	C-15	C-15	C-15	C-15	C-17	C-17	C-17	C-17
<b>Single-Circuit Coils</b>												
<b>No. of TXVs</b>	—	—	—	—	—	—	—	—	—	—	—	—
<b>Suction Connections (in. OD)</b>	—	—	—	—	—	—	—	—	—	—	—	—
<b>Distributor Connections (in. OD)</b>	—	—	—	—	—	—	—	—	—	—	—	—
<b>Distributor Nozzle Size</b>	—	—	—	—	—	—	—	—	—	—	—	—

LEGEND

TXV — Thermostatic Expansion Valve (Field Supplied)

\*When 2 nozzle sizes are listed, the smaller nozzle should be located on the upper distributor.

NOTE: Factory-supplied distributors have factory-selected nozzle sizes as shown. If necessary, replace factory-supplied nozzles with field-supplied and field-installed nozzles. Consult AHUBuilder® software selection program for correct nozzle selection.

# Physical data (cont)



## DIRECT-EXPANSION CIRCUITING DATA (cont) MEDIUM FACE AREA COILS (cont)

CIRCUITING TYPE	39M UNIT SIZE				85W				96W				110W			
	Full		Double		Full		Double		Full		Double		Full		Double	
Airflow (cfm) at 500 fpm					35,000				39,375				45,000			
Total Face Area (sq ft)					70.0				78.8				90.0			
Tubes in Face	32	32	32	32	36	36	36	36	36	36	36	36	36	36	36	36
Tube Length (in.)	126	126	126	126	126	126	126	126	144	144	144	144	144	144	144	144
No. of Circuits - Total	32	32	64	64	36	36	72	72	36	36	72	72	36	36	72	72
<b>4-Row Coil</b>																
<b>Face Split Coils</b>																
No. of TXVs	2	2	—	—	2	2	—	—	2	2	—	—	2	2	—	—
Suction Connections (in. OD)	1 <sup>5</sup> / <sub>8</sub>	1 <sup>5</sup> / <sub>8</sub>	—	—	1 <sup>5</sup> / <sub>8</sub>	1 <sup>5</sup> / <sub>8</sub>	—	—	1 <sup>5</sup> / <sub>8</sub>	1 <sup>5</sup> / <sub>8</sub>	—	—	1 <sup>5</sup> / <sub>8</sub>	1 <sup>5</sup> / <sub>8</sub>	—	—
Distributor Connections (in. OD)	1 <sup>3</sup> / <sub>8</sub>	1 <sup>3</sup> / <sub>8</sub>	—	—	1 <sup>3</sup> / <sub>8</sub>	1 <sup>3</sup> / <sub>8</sub>	—	—	1 <sup>3</sup> / <sub>8</sub>	1 <sup>3</sup> / <sub>8</sub>	—	—	1 <sup>3</sup> / <sub>8</sub>	1 <sup>3</sup> / <sub>8</sub>	—	—
Distributor Nozzle Size*	C-17	C-17	—	—	C-17	C-17	—	—	C-17	C-17	—	—	C-17	C-17	—	—
<b>Intertwined Row Split Coils</b>																
No. of TXVs	2	2	—	—	2	2	—	—	2	2	—	—	2	2	—	—
Suction Connections (in. OD)	1 <sup>5</sup> / <sub>8</sub>	1 <sup>5</sup> / <sub>8</sub>	—	—	1 <sup>5</sup> / <sub>8</sub>	1 <sup>5</sup> / <sub>8</sub>	—	—	1 <sup>5</sup> / <sub>8</sub>	1 <sup>5</sup> / <sub>8</sub>	—	—	1 <sup>5</sup> / <sub>8</sub>	1 <sup>5</sup> / <sub>8</sub>	—	—
Distributor Connections (in. OD)	1 <sup>3</sup> / <sub>8</sub>	1 <sup>3</sup> / <sub>8</sub>	—	—	1 <sup>3</sup> / <sub>8</sub>	1 <sup>3</sup> / <sub>8</sub>	—	—	1 <sup>3</sup> / <sub>8</sub>	1 <sup>3</sup> / <sub>8</sub>	—	—	1 <sup>3</sup> / <sub>8</sub>	1 <sup>3</sup> / <sub>8</sub>	—	—
Distributor Nozzle Size*	C-17	C-17	—	—	C-17	C-17	—	—	C-17	C-17	—	—	C-17	C-17	—	—
<b>Single-Circuit Coils</b>																
No. of TXVs	—	—	—	—	—	—	—	—	—	—	—	—	—	—	—	—
Suction Connections (in. OD)	—	—	—	—	—	—	—	—	—	—	—	—	—	—	—	—
Distributor Connections (in. OD)	—	—	—	—	—	—	—	—	—	—	—	—	—	—	—	—
Distributor Nozzle Size	—	—	—	—	—	—	—	—	—	—	—	—	—	—	—	—
<b>6-Row Coil</b>																
<b>Face Split Coils</b>																
No. of TXVs	2	2	—	—	2	2	—	—	2	2	—	—	2	2	—	—
Suction Connections (in. OD)	1 <sup>5</sup> / <sub>8</sub>	1 <sup>5</sup> / <sub>8</sub>	—	—	1 <sup>5</sup> / <sub>8</sub>	1 <sup>5</sup> / <sub>8</sub>	—	—	1 <sup>5</sup> / <sub>8</sub>	1 <sup>5</sup> / <sub>8</sub>	—	—	1 <sup>5</sup> / <sub>8</sub>	1 <sup>5</sup> / <sub>8</sub>	—	—
Distributor Connections (in. OD)	1 <sup>3</sup> / <sub>8</sub>	1 <sup>3</sup> / <sub>8</sub>	—	—	1 <sup>3</sup> / <sub>8</sub>	1 <sup>3</sup> / <sub>8</sub>	—	—	1 <sup>3</sup> / <sub>8</sub>	1 <sup>3</sup> / <sub>8</sub>	—	—	1 <sup>3</sup> / <sub>8</sub>	1 <sup>3</sup> / <sub>8</sub>	—	—
Distributor Nozzle Size*	C-17	C-17	—	—	C-17	C-17	—	—	C-17	C-17	—	—	C-17	C-17	—	—
<b>Intertwined Row Split Coils</b>																
No. of TXVs	2	2	—	—	2	2	—	—	2	2	—	—	2	2	—	—
Suction Connections (in. OD)	1 <sup>5</sup> / <sub>8</sub>	1 <sup>5</sup> / <sub>8</sub>	—	—	1 <sup>5</sup> / <sub>8</sub>	1 <sup>5</sup> / <sub>8</sub>	—	—	1 <sup>5</sup> / <sub>8</sub>	1 <sup>5</sup> / <sub>8</sub>	—	—	1 <sup>5</sup> / <sub>8</sub>	1 <sup>5</sup> / <sub>8</sub>	—	—
Distributor Connections (in. OD)	1 <sup>3</sup> / <sub>8</sub>	1 <sup>3</sup> / <sub>8</sub>	—	—	1 <sup>3</sup> / <sub>8</sub>	1 <sup>3</sup> / <sub>8</sub>	—	—	1 <sup>3</sup> / <sub>8</sub>	1 <sup>3</sup> / <sub>8</sub>	—	—	1 <sup>3</sup> / <sub>8</sub>	1 <sup>3</sup> / <sub>8</sub>	—	—
Distributor Nozzle Size*	C-17	C-17	—	—	C-17	C-17	—	—	C-17	C-17	—	—	C-17	C-17	—	—
<b>Single-Circuit Coils</b>																
No. of TXVs	—	—	—	—	—	—	—	—	—	—	—	—	—	—	—	—
Suction Connections (in. OD)	—	—	—	—	—	—	—	—	—	—	—	—	—	—	—	—
Distributor Connections (in. OD)	—	—	—	—	—	—	—	—	—	—	—	—	—	—	—	—
Distributor Nozzle Size	—	—	—	—	—	—	—	—	—	—	—	—	—	—	—	—
<b>8-Row Coil</b>																
<b>Face Split Coils</b>																
No. of TXVs	2	2	4	4	2	2	4	4	2	2	4	4	2	2	4	4
Suction Connections (in. OD)	1 <sup>5</sup> / <sub>8</sub>	1 <sup>5</sup> / <sub>8</sub>	1 <sup>5</sup> / <sub>8</sub>	1 <sup>5</sup> / <sub>8</sub>	1 <sup>5</sup> / <sub>8</sub>	1 <sup>5</sup> / <sub>8</sub>	1 <sup>5</sup> / <sub>8</sub>	1 <sup>5</sup> / <sub>8</sub>	1 <sup>5</sup> / <sub>8</sub>	1 <sup>5</sup> / <sub>8</sub>	1 <sup>5</sup> / <sub>8</sub>	1 <sup>5</sup> / <sub>8</sub>	1 <sup>5</sup> / <sub>8</sub>	1 <sup>5</sup> / <sub>8</sub>	1 <sup>5</sup> / <sub>8</sub>	1 <sup>5</sup> / <sub>8</sub>
Distributor Connections (in. OD)	1 <sup>3</sup> / <sub>8</sub>	1 <sup>3</sup> / <sub>8</sub>	1 <sup>3</sup> / <sub>8</sub>	1 <sup>3</sup> / <sub>8</sub>	1 <sup>3</sup> / <sub>8</sub>	1 <sup>3</sup> / <sub>8</sub>	1 <sup>3</sup> / <sub>8</sub>	1 <sup>3</sup> / <sub>8</sub>	1 <sup>3</sup> / <sub>8</sub>	1 <sup>3</sup> / <sub>8</sub>	1 <sup>3</sup> / <sub>8</sub>	1 <sup>3</sup> / <sub>8</sub>	1 <sup>3</sup> / <sub>8</sub>	1 <sup>3</sup> / <sub>8</sub>	1 <sup>3</sup> / <sub>8</sub>	1 <sup>3</sup> / <sub>8</sub>
Distributor Nozzle Size*	C-17	C-17	C-17	C-17	C-17	C-17	C-17	C-17	C-17	C-17	C-17	C-17	C-17	C-17	C-17	C-17
<b>Intertwined Row Split Coils</b>																
No. of TXVs	2	2	4	4	2	2	4	4	2	2	4	4	2	2	4	4
Suction Connections (in. OD)	1 <sup>5</sup> / <sub>8</sub>	1 <sup>5</sup> / <sub>8</sub>	1 <sup>5</sup> / <sub>8</sub>	1 <sup>5</sup> / <sub>8</sub>	1 <sup>5</sup> / <sub>8</sub>	1 <sup>5</sup> / <sub>8</sub>	1 <sup>5</sup> / <sub>8</sub>	1 <sup>5</sup> / <sub>8</sub>	1 <sup>5</sup> / <sub>8</sub>	1 <sup>5</sup> / <sub>8</sub>	1 <sup>5</sup> / <sub>8</sub>	1 <sup>5</sup> / <sub>8</sub>	1 <sup>5</sup> / <sub>8</sub>	1 <sup>5</sup> / <sub>8</sub>	1 <sup>5</sup> / <sub>8</sub>	1 <sup>5</sup> / <sub>8</sub>
Distributor Connections (in. OD)	1 <sup>3</sup> / <sub>8</sub>	1 <sup>3</sup> / <sub>8</sub>	1 <sup>3</sup> / <sub>8</sub>	1 <sup>3</sup> / <sub>8</sub>	1 <sup>3</sup> / <sub>8</sub>	1 <sup>3</sup> / <sub>8</sub>	1 <sup>3</sup> / <sub>8</sub>	1 <sup>3</sup> / <sub>8</sub>	1 <sup>3</sup> / <sub>8</sub>	1 <sup>3</sup> / <sub>8</sub>	1 <sup>3</sup> / <sub>8</sub>	1 <sup>3</sup> / <sub>8</sub>	1 <sup>3</sup> / <sub>8</sub>	1 <sup>3</sup> / <sub>8</sub>	1 <sup>3</sup> / <sub>8</sub>	1 <sup>3</sup> / <sub>8</sub>
Distributor Nozzle Size*	C-17	C-17	C-17	C-17	C-17	C-17	C-17	C-17	C-17	C-17	C-17	C-17	C-17	C-17	C-17	C-17
<b>Single-Circuit Coils</b>																
No. of TXVs	—	—	—	—	—	—	—	—	—	—	—	—	—	—	—	—
Suction Connections (in. OD)	—	—	—	—	—	—	—	—	—	—	—	—	—	—	—	—
Distributor Connections (in. OD)	—	—	—	—	—	—	—	—	—	—	—	—	—	—	—	—
Distributor Nozzle Size	—	—	—	—	—	—	—	—	—	—	—	—	—	—	—	—

**LEGEND**

TXV — Thermostatic Expansion Valve (Field Supplied)

\*When 2 nozzle sizes are listed, the smaller nozzle should be located on the upper distributor.

NOTE: Factory-supplied distributors have factory-selected nozzle sizes as shown. If necessary, replace factory-supplied nozzles with field-supplied and field-installed nozzles. Consult AHUBuilder® software selection program for correct nozzle selection.

## DIRECT-EXPANSION CIRCUITING DATA (cont) LARGE FACE AREA COILS

39M UNIT SIZE	03W			06W			08W			10W			12W			14W		
	Quarter	Half	Full	Quarter	Half	Full	Quarter	Half	Full	Quarter	Half	Full	Quarter	Half	Full	Quarter	Half	Full
<b>CIRCUITING TYPE</b>																		
Airflow (cfm) at 500 fpm	1,736			2,951			3,819			4,965			6,319			7,170		
Total Face Area (sq ft)	3.5			5.9			7.6			9.9			12.6			14.3		
Tubes in Face	20	20	20	20	20	20	22	22	22	22	22	22	28	28	28	28	28	28
Tube Length (in.)	20	20	20	34	34	34	40	40	40	52	52	52	52	52	52	59	59	59
No. of Circuits - Total	4	10	20	4	10	20	6	11	22	6	11	22	7	14	28	7	14	28
<b>4-Row Coil</b>																		
<b>Face Split Coils</b>																		
No. of TXVs	2	2	—	2	2	—	2	2	—	2	2	—	2	2	—	2	2	—
Suction Connections (in. OD)	7/8	1 1/8	—	7/8	1 1/8	—	7/8	1 1/8	—	7/8	1 1/8	—	7/8	1 1/8	—	7/8	1 1/8	—
Distributor Connections (in. OD)	7/8	7/8	—	7/8	7/8	—	7/8	7/8	—	7/8	7/8	—	7/8	7/8	—	7/8	7/8	—
Distributor Nozzle Size*	G-1.5	G-3	—	G-1.5	G-3	—	G-2	G-4/G-3	—	G-2	G-4/G-3	—	G-2.5/G-2	G-6	—	G-2.5/G-2	G-6	—
<b>Intertwined Row Split Coils</b>																		
No. of TXVs	2	2	—	2	2	—	2	2	—	2	2	—	2	2	—	2	2	—
Suction Connections (in. OD)	7/8	1 1/8	—	7/8	1 1/8	—	7/8	1 1/8	—	7/8	1 1/8	—	7/8	1 1/8	—	7/8	1 1/8	—
Distributor Connections (in. OD)	7/8	7/8	—	7/8	7/8	—	7/8	7/8	—	7/8	7/8	—	7/8	7/8	—	7/8	7/8	—
Distributor Nozzle Size*	G-1.5	G-3	—	G-1.5	G-3	—	G-2	G-4/G-3	—	G-2	G-4/G-3	—	G-2.5/G-2	G-6	—	G-2.5/G-2	G-6	—
<b>Single-Circuit Coils</b>																		
No. of TXVs	1	1	—	1	1	—	1	1	—	1	1	—	1	1	—	1	1	—
Suction Connections (in. OD)	1 1/8	1 3/8	—	1 1/8	1 3/8	—	1 1/8	1 3/8	—	1 1/8	1 3/8	—	1 1/8	1 3/8	—	1 1/8	1 3/8	—
Distributor Connections (in. OD)	7/8	1 1/8	—	7/8	1 1/8	—	7/8	1 1/8	—	7/8	1 1/8	—	7/8	1 1/8	—	7/8	1 1/8	—
Distributor Nozzle Size	G-3	E-10	—	G-3	E-10	—	G-4	E-12	—	G-4	E-12	—	G-6	C-15	—	G-6	C-15	—
<b>6-Row Coil</b>																		
<b>Face Split Coils</b>																		
No. of TXVs	2	2	—	2	2	—	2	2	—	2	2	—	2	2	—	2	2	—
Suction Connections (in. OD)	7/8	1 1/8	—	7/8	1 1/8	—	7/8	1 1/8	—	7/8	1 1/8	—	7/8	1 1/8	—	7/8	1 1/8	—
Distributor Connections (in. OD)	7/8	7/8	—	7/8	7/8	—	7/8	7/8	—	7/8	7/8	—	7/8	7/8	—	7/8	7/8	—
Distributor Nozzle Size*	G-1.5	G-3	—	G-1.5	G-3	—	G-2	G-4/G-3	—	E-12	G-2	—	G-4/G-3	E-12	—	G-6	C-15	—
<b>Intertwined Row Split Coils</b>																		
No. of TXVs	2	2	—	2	2	—	2	2	—	2	2	—	2	2	—	2	2	—
Suction Connections (in. OD)	7/8	1 1/8	—	7/8	1 1/8	—	7/8	1 1/8	—	7/8	1 1/8	—	7/8	1 1/8	—	7/8	1 1/8	—
Distributor Connections (in. OD)	7/8	7/8	—	7/8	7/8	—	7/8	7/8	—	7/8	7/8	—	7/8	7/8	—	7/8	7/8	—
Distributor Nozzle Size*	G-1.5	G-3	—	G-1.5	G-3	—	G-2	G-4/G-3	—	E-12	G-2	—	G-4/G-3	E-12	—	G-6	C-15	—
<b>Single-Circuit Coils</b>																		
No. of TXVs	1	1	—	1	1	—	1	1	—	1	1	—	1	1	—	1	1	—
Suction Connections (in. OD)	1 1/8	1 3/8	—	1 1/8	1 3/8	—	1 1/8	1 3/8	—	1 1/8	1 3/8	—	1 1/8	1 3/8	—	1 1/8	1 3/8	—
Distributor Connections (in. OD)	7/8	1 1/8	—	7/8	1 1/8	—	7/8	1 1/8	—	7/8	1 1/8	—	7/8	1 1/8	—	7/8	1 1/8	—
Distributor Nozzle Size	G-3	E-10	—	G-3	E-10	—	G-4	E-12	—	G-4	E-12	—	—	—	—	C-15	—	—
<b>8-Row Coil</b>																		
<b>Face Split Coils</b>																		
No. of TXVs	—	2	2	—	2	2	—	2	2	—	2	2	—	2	2	—	2	2
Suction Connections (in. OD)	—	1 1/8	1 3/8	—	1 1/8	1 3/8	—	1 1/8	1 3/8	—	1 1/8	1 3/8	—	1 1/8	1 3/8	—	1 1/8	1 3/8
Distributor Connections (in. OD)	—	7/8	1 1/8	—	7/8	1 1/8	—	7/8	1 1/8	—	7/8	1 1/8	—	7/8	1 1/8	—	7/8	1 1/8
Distributor Nozzle Size*	—	G-3	E-10	—	G-3	E-10	—	G-4/G-3	E-12	—	G-4/G-3	E-12	—	G-6	C-15	—	G-6	C-15
<b>Intertwined Row Split Coils</b>																		
No. of TXVs	—	2	—	—	2	—	—	2	—	—	2	—	—	2	—	—	2	—
Suction Connections (in. OD)	—	1 1/8	—	—	1 1/8	—	—	1 1/8	—	—	1 1/8	—	—	1 1/8	—	—	1 1/8	—
Distributor Connections (in. OD)	—	7/8	—	—	7/8	—	—	7/8	—	—	7/8	—	—	7/8	—	—	7/8	—
Distributor Nozzle Size*	—	G-3	—	—	G-3	—	—	G-4/G-3	—	—	G-4/G-3	—	—	G-6	—	—	G-6	—
<b>Single-Circuit Coils</b>																		
No. of TXVs	—	1	—	—	1	—	—	1	—	—	1	—	—	1	—	—	1	—
Suction Connections (in. OD)	—	1 3/8	—	—	1 3/8	—	—	1 3/8	—	—	1 3/8	—	—	1 3/8	—	—	1 3/8	—
Distributor Connections (in. OD)	—	1 1/8	—	—	1 1/8	—	—	1 1/8	—	—	1 1/8	—	—	1 3/8	—	—	1 3/8	—
Distributor Nozzle Size	—	E-10	—	—	E-10	—	—	E-12	—	—	E-12	—	—	C-15	—	—	C-15	—

**LEGEND**

TXV — Thermostatic Expansion Valve (Field Supplied)

\*When 2 nozzle sizes are listed, the smaller nozzle should be located on the upper distributor.

NOTE: Factory-supplied distributors have factory-selected nozzle sizes as shown. If necessary, replace factory-supplied nozzles with field-supplied and field-installed nozzles. Consult AHUBuilder® software selection program for correct nozzle selection.

# Physical data (cont)



## → DIRECT-EXPANSION CIRCUITING DATA (cont) LARGE FACE AREA COILS (cont)

CIRCUITING TYPE	16T								17W			18T					
	Quarter		Half		Full		Double		Half	Full	Double	Half		Full		Double	
Airflow (cfm) at 500 fpm	7,587								8,464			8,898					
Total Face Area (sq ft)	15.2								16.9			17.8					
	Upper	Lower	Upper	Lower	Upper	Lower	Upper	Lower				Upper	Lower	Upper	Lower	Upper	Lower
Tubes in Face	22	24	22	24	22	24	22	24	30	30	30	24	26	24	26	24	26
Tube Length (in.)	38	38	38	38	38	38	38	38	65	65	65	41	41	41	41	41	41
No. of Circuits - Total	6	6	11	12	22	24	44	48	15	30	60	12	13	24	26	48	52
<b>4-Row Coil</b>																	
<b>Face Split Coils</b>																	
No. of TXVs	2	2	2	2	2	2	—	—	2	2	—	2	2	2	2	—	—
Suction Connections (in. OD)	7/8	7/8	1 1/8	1 1/8	1 3/8	1 3/8	—	—	1 1/8	1 5/8	—	1 1/8	1 5/8	1 3/8	1 5/8	—	—
Distributor Connections (in. OD)	7/8	7/8	7/8	7/8	1 1/8	1 3/8	—	—	7/8	1 3/8	—	7/8	1 3/8	1 3/8	1 3/8	—	—
Distributor Nozzle Size*	G-2	G-2	G-4/G-3	G-4	E-12	C-12	—	—	G-8/G-6	C-15	—	G-4	G-6/6-4	C-12	C-12	—	—
<b>Intertwined Row Split Coils</b>																	
No. of TXVs	2	2	2	2	2	2	—	—	2	2	—	2	1	2	2	—	—
Suction Connections (in. OD)	7/8	7/8	1 1/8	1 1/8	1 3/8	1 3/8	—	—	1 1/8	1 5/8	—	1 1/8	1 5/8	1 3/8	1 5/8	—	—
Distributor Connections (in. OD)	7/8	7/8	7/8	7/8	1 1/8	1 3/8	—	—	7/8	1 3/8	—	7/8	1 3/8	1 3/8	1 3/8	—	—
Distributor Nozzle Size*	G-2	G-2	G-4/G-3	G-4	E-12	C-12	—	—	G-8/G-6	C-15	—	G-4	G-6/6-4	C-12	C-12	—	—
<b>Single-Circuit Coils</b>																	
No. of TXVs	1	1	1	1	—	—	—	—	1	—	—	—	—	—	—	—	—
Suction Connections (in. OD)	1 1/8	1 1/8	1 3/8	1 3/8	—	—	—	—	1 5/8	—	—	—	—	—	—	—	—
Distributor Connections (in. OD)	7/8	7/8	1 1/8	1 1/8	—	—	—	—	1 3/8	—	—	—	—	—	—	—	—
Distributor Nozzle Size	G-4	G-4	E-12	C-12	—	—	—	—	C-15	—	—	—	—	—	—	—	—
<b>6-Row Coil</b>																	
<b>Face Split Coils</b>																	
No. of TXVs	2	2	2	2	2	2	—	—	2	2	—	2	1	2	2	—	—
Suction Connections (in. OD)	7/8	7/8	1 1/8	1 1/8	1 3/8	1 3/8	—	—	1 1/8	1 5/8	—	1 1/8	1 5/8	1 3/8	1 5/8	—	—
Distributor Connections (in. OD)	7/8	7/8	7/8	7/8	1 1/8	1 3/8	—	—	7/8	1 3/8	—	7/8	1 3/8	1 3/8	1 3/8	—	—
Distributor Nozzle Size*	G-2	G-2	G-4/G-3	G-4	E-12	C-12	—	—	G-8/G-6	C-15	—	G-4	G-6/6-4	C-12	C-12	—	—
<b>Intertwined Row Split Coils</b>																	
No. of TXVs	2	2	2	2	2	2	—	—	2	2	—	2	2	2	2	—	—
Suction Connections (in. OD)	7/8	7/8	1 1/8	1 1/8	1 3/8	1 3/8	—	—	1 1/8	1 5/8	—	1 1/8	1 5/8	1 3/8	1 5/8	—	—
Distributor Connections (in. OD)	7/8	7/8	7/8	7/8	1 1/8	1 3/8	—	—	7/8	1 3/8	—	7/8	1 3/8	1 3/8	1 3/8	—	—
Distributor Nozzle Size*	G-2	G-2	G-4/G-3	G-4	E-12	C-12	—	—	G-8/G-6	C-15	—	G-4	G-6/6-4	C-12	C-12	—	—
<b>Single-Circuit Coils</b>																	
No. of TXVs	1	1	1	1	—	—	—	—	1	—	—	—	—	—	—	—	—
Suction Connections (in. OD)	1 1/8	1 1/8	1 3/8	1 3/8	—	—	—	—	1 5/8	—	—	—	—	—	—	—	—
Distributor Connections (in. OD)	7/8	7/8	1 1/8	1 1/8	—	—	—	—	1 3/8	—	—	—	—	—	—	—	—
Distributor Nozzle Size	G-4	G-4	E-12	C-12	—	—	—	—	C-15	—	—	—	—	—	—	—	—
<b>8-Row Coil</b>																	
<b>Face Split Coils</b>																	
No. of TXVs	—	—	2	2	2	2	4	4	4	2	4	2	2	2	2	4	4
Suction Connections (in. OD)	—	—	1 1/8	1 1/8	1 3/8	1 3/8	1 3/8	1 3/8	1 1/8	1 5/8	1 5/8	1 1/8	1 5/8	1 3/8	1 5/8	1 3/8	1 5/8
Distributor Connections (in. OD)	—	—	7/8	7/8	1 1/8	1 3/8	1 1/8	1 3/8	7/8	1 3/8	1 3/8	7/8	1 3/8	1 3/8	1 3/8	1 3/8	1 3/8
Distributor Nozzle Size*	—	—	G-4/G-3	G-4	E-12	C-12	E-12	C-12	G-8/G-6	C-15	C-15	G-4	G-6/6-4	C-12	C-12	C-12	C-12
<b>Intertwined Row Split Coils</b>																	
No. of TXVs	—	—	2	2	2	2	4	4	4	1	4	2	2	2	2	4	4
Suction Connections (in. OD)	—	—	1 1/8	1 1/8	1 3/8	1 3/8	1 3/8	1 3/8	1 1/8	1 5/8	1 5/8	1 1/8	1 1/8	1 3/8	1 5/8	1 3/8	1 5/8
Distributor Connections (in. OD)	—	—	7/8	7/8	1 1/8	1 3/8	1 1/8	1 3/8	7/8	1 3/8	1 3/8	7/8	7/8	1 3/8	1 3/8	1 3/8	1 3/8
Distributor Nozzle Size*	—	—	G-4/G-3	G-4	E-12	C-12	E-12	C-12	G-8/G-6	C-15	C-15	G-4	G-6	C-12	C-12	C-12	C-12
<b>Single-Circuit Coils</b>																	
No. of TXVs	—	—	1	1	—	—	—	—	1	—	—	—	—	—	—	—	—
Suction Connections (in. OD)	—	—	1 3/8	1 3/8	—	—	—	—	1 5/8	—	—	—	—	—	—	—	—
Distributor Connections (in. OD)	—	—	1 1/8	1 3/8	—	—	—	—	1 3/8	—	—	—	—	—	—	—	—
Distributor Nozzle Size	—	—	E-12	C-12	—	—	—	—	C-15	—	—	—	—	—	—	—	—

LEGEND  
 TXV — Thermostatic Expansion Valve (Field Supplied)  
 \*When 2 nozzle sizes are listed, the smaller nozzle should be located on the upper distributor.

NOTE: Factory-supplied distributors have factory-selected nozzle sizes as shown. If necessary, replace factory-supplied nozzles with field-supplied and field-installed nozzles. Consult AHUBuilder® software selection program for correct nozzle selection.

→ **DIRECT-EXPANSION CIRCUITING DATA (cont)**  
**LARGE FACE AREA COILS (cont)**

39M UNIT SIZE	21W			22T						25W		
	Half	Full	Double	Half		Full		Double		Half	Full	Double
<b>CIRCUITING TYPE</b>												
Airflow (cfm) at 500 fpm	10,720			11,016						12,205		
Total Face Area (sq ft)	21.4			22.0						24.4		
				Upper	Lower	Upper	Lower	Upper	Lower			
<b>Tubes in Face</b>	38	38	38	26	28	26	28	26	28	38	38	38
<b>Tube Length (in.)</b>	65	65	65	47	47	47	47	47	47	72	72	72
<b>No. of Circuits - Total</b>	19	38	76	13	14	26	28	52	56	19	38	76
<b>4-Row Coil</b>												
<b>Face Split Coils</b>												
No. of TXVs	2	2	—	2	2	2	2	—	—	2	2	—
Suction Connections (in. OD)	1 <sup>3</sup> / <sub>8</sub>	1 <sup>5</sup> / <sub>8</sub>	—	1 <sup>5</sup> / <sub>8</sub>	1 <sup>1</sup> / <sub>8</sub>	1 <sup>5</sup> / <sub>8</sub>	1 <sup>5</sup> / <sub>8</sub>	—	—	1 <sup>3</sup> / <sub>8</sub>	1 <sup>5</sup> / <sub>8</sub>	—
Distributor Connections (in. OD)	1 <sup>1</sup> / <sub>8</sub>	1 <sup>3</sup> / <sub>8</sub>	—	1 <sup>3</sup> / <sub>8</sub>	7 <sup>8</sup> / <sub>8</sub>	1 <sup>3</sup> / <sub>8</sub>	1 <sup>3</sup> / <sub>8</sub>	—	—	1 <sup>1</sup> / <sub>8</sub>	1 <sup>3</sup> / <sub>8</sub>	—
Distributor Nozzle Size*	E-10/E-8	C-20	—	G-6/6-4	G-6	C-12	C-15	—	—	E-10/E-8	C-20	—
<b>Intertwined Row Split Coils</b>												
No. of TXVs	2	2	—	2	2	2	2	—	—	2	2	—
Suction Connections (in. OD)	1 <sup>3</sup> / <sub>8</sub>	1 <sup>5</sup> / <sub>8</sub>	—	1 <sup>5</sup> / <sub>8</sub>	1 <sup>1</sup> / <sub>8</sub>	1 <sup>5</sup> / <sub>8</sub>	1 <sup>5</sup> / <sub>8</sub>	—	—	1 <sup>3</sup> / <sub>8</sub>	1 <sup>5</sup> / <sub>8</sub>	—
Distributor Connections (in. OD)	1 <sup>1</sup> / <sub>8</sub>	1 <sup>3</sup> / <sub>8</sub>	—	1 <sup>3</sup> / <sub>8</sub>	7 <sup>8</sup> / <sub>8</sub>	1 <sup>3</sup> / <sub>8</sub>	1 <sup>3</sup> / <sub>8</sub>	—	—	1 <sup>1</sup> / <sub>8</sub>	1 <sup>3</sup> / <sub>8</sub>	—
Distributor Nozzle Size*	E-10/E-8	C-20	—	G-6/6-4	G-6	C-12	C-15	—	—	E-10/E-8	C-20	—
<b>Single-Circuit Coils</b>												
No. of TXVs	—	—	—	—	—	—	—	—	—	—	—	—
Suction Connections (in. OD)	—	—	—	—	—	—	—	—	—	—	—	—
Distributor Connections (in. OD)	—	—	—	—	—	—	—	—	—	—	—	—
Distributor Nozzle Size	—	—	—	—	—	—	—	—	—	—	—	—
<b>6-Row Coil</b>												
<b>Face Split Coils</b>												
No. of TXVs	2	2	—	2	2	2	2	—	—	2	2	—
Suction Connections (in. OD)	1 <sup>3</sup> / <sub>8</sub>	1 <sup>5</sup> / <sub>8</sub>	—	1 <sup>5</sup> / <sub>8</sub>	1 <sup>1</sup> / <sub>8</sub>	1 <sup>5</sup> / <sub>8</sub>	1 <sup>5</sup> / <sub>8</sub>	—	—	1 <sup>3</sup> / <sub>8</sub>	1 <sup>5</sup> / <sub>8</sub>	—
Distributor Connections (in. OD)	1 <sup>1</sup> / <sub>8</sub>	1 <sup>3</sup> / <sub>8</sub>	—	1 <sup>3</sup> / <sub>8</sub>	7 <sup>8</sup> / <sub>8</sub>	1 <sup>3</sup> / <sub>8</sub>	1 <sup>3</sup> / <sub>8</sub>	—	—	1 <sup>1</sup> / <sub>8</sub>	1 <sup>3</sup> / <sub>8</sub>	—
Distributor Nozzle Size*	E-10/E-8	C-20	—	G-6/6-4	G-6	C-12	C-15	—	—	E-10/E-8	C-20	—
<b>Intertwined Row Split Coils</b>												
No. of TXVs	2	2	—	2	2	2	2	—	—	2	2	—
Suction Connections (in. OD)	1 <sup>3</sup> / <sub>8</sub>	1 <sup>5</sup> / <sub>8</sub>	—	1 <sup>5</sup> / <sub>8</sub>	1 <sup>1</sup> / <sub>8</sub>	1 <sup>5</sup> / <sub>8</sub>	1 <sup>5</sup> / <sub>8</sub>	—	—	1 <sup>3</sup> / <sub>8</sub>	1 <sup>5</sup> / <sub>8</sub>	—
Distributor Connections (in. OD)	1 <sup>1</sup> / <sub>8</sub>	1 <sup>3</sup> / <sub>8</sub>	—	1 <sup>3</sup> / <sub>8</sub>	7 <sup>8</sup> / <sub>8</sub>	1 <sup>3</sup> / <sub>8</sub>	1 <sup>3</sup> / <sub>8</sub>	—	—	1 <sup>1</sup> / <sub>8</sub>	1 <sup>3</sup> / <sub>8</sub>	—
Distributor Nozzle Size*	E-10/E-8	C-20	—	G-6/6-4	G-6	C-12	C-15	—	—	E-10/E-8	C-20	—
<b>Single-Circuit Coils</b>												
No. of TXVs	—	—	—	—	—	—	—	—	—	—	—	—
Suction Connections (in. OD)	—	—	—	—	—	—	—	—	—	—	—	—
Distributor Connections (in. OD)	—	—	—	—	—	—	—	—	—	—	—	—
Distributor Nozzle Size	—	—	—	—	—	—	—	—	—	—	—	—
<b>8-Row Coil</b>												
<b>Face Split Coils</b>												
No. of TXVs	2	2	4	2	2	2	2	4	4	2	2	4
Suction Connections (in. OD)	1 <sup>3</sup> / <sub>8</sub>	1 <sup>5</sup> / <sub>8</sub>	1 <sup>5</sup> / <sub>8</sub>	1 <sup>5</sup> / <sub>8</sub>	1 <sup>5</sup> / <sub>8</sub>	1 <sup>5</sup> / <sub>8</sub>	1 <sup>5</sup> / <sub>8</sub>	1 <sup>5</sup> / <sub>8</sub>	1 <sup>5</sup> / <sub>8</sub>	1 <sup>3</sup> / <sub>8</sub>	1 <sup>5</sup> / <sub>8</sub>	1 <sup>5</sup> / <sub>8</sub>
Distributor Connections (in. OD)	1 <sup>1</sup> / <sub>8</sub>	1 <sup>3</sup> / <sub>8</sub>	1 <sup>3</sup> / <sub>8</sub>	1 <sup>3</sup> / <sub>8</sub>	7 <sup>8</sup> / <sub>8</sub>	1 <sup>3</sup> / <sub>8</sub>	1 <sup>3</sup> / <sub>8</sub>	1 <sup>3</sup> / <sub>8</sub>	1 <sup>3</sup> / <sub>8</sub>	1 <sup>1</sup> / <sub>8</sub>	1 <sup>3</sup> / <sub>8</sub>	1 <sup>3</sup> / <sub>8</sub>
Distributor Nozzle Size*	E-10/E-8	C-20	C-20	G-6/6-4	G-6	C-12	C-15	C-12	C-15	E-10/E-8	C-20	C-20
<b>Intertwined Row Split Coils</b>												
No. of TXVs	2	2	4	2	2	2	2	4	4	2	2	4
Suction Connections (in. OD)	1 <sup>3</sup> / <sub>8</sub>	1 <sup>5</sup> / <sub>8</sub>	1 <sup>5</sup> / <sub>8</sub>	1 <sup>5</sup> / <sub>8</sub>	1 <sup>1</sup> / <sub>8</sub>	1 <sup>5</sup> / <sub>8</sub>	1 <sup>5</sup> / <sub>8</sub>	1 <sup>5</sup> / <sub>8</sub>	1 <sup>5</sup> / <sub>8</sub>	1 <sup>3</sup> / <sub>8</sub>	1 <sup>5</sup> / <sub>8</sub>	1 <sup>5</sup> / <sub>8</sub>
Distributor Connections (in. OD)	1 <sup>1</sup> / <sub>8</sub>	1 <sup>3</sup> / <sub>8</sub>	1 <sup>3</sup> / <sub>8</sub>	1 <sup>3</sup> / <sub>8</sub>	7 <sup>8</sup> / <sub>8</sub>	1 <sup>3</sup> / <sub>8</sub>	1 <sup>3</sup> / <sub>8</sub>	1 <sup>3</sup> / <sub>8</sub>	1 <sup>3</sup> / <sub>8</sub>	1 <sup>1</sup> / <sub>8</sub>	1 <sup>3</sup> / <sub>8</sub>	1 <sup>3</sup> / <sub>8</sub>
Distributor Nozzle Size*	E-10/E-8	C-20	C-20	G-6	G-6	C-12	C-15	C-12	C-15	E-10/E-8	C-20	C-20
<b>Single-Circuit Coils</b>												
No. of TXVs	—	—	—	—	—	—	—	—	—	—	—	—
Suction Connections (in. OD)	—	—	—	—	—	—	—	—	—	—	—	—
Distributor Connections (in. OD)	—	—	—	—	—	—	—	—	—	—	—	—
Distributor Nozzle Size	—	—	—	—	—	—	—	—	—	—	—	—

**LEGEND**

**TXV** — Thermostatic Expansion Valve (Field Supplied)

\*When 2 nozzle sizes are listed, the smaller nozzle should be located on the upper distributor.

**NOTE:** Factory-supplied distributors have factory-selected nozzle sizes as shown. If necessary, replace factory-supplied nozzles with field-supplied and field-installed nozzles. Consult **AHUBuilder®** software selection program for correct nozzle selection.

# Physical data (cont)



## → DIRECT-EXPANSION CIRCUITING DATA (cont) LARGE FACE AREA COILS (cont)

39M UNIT SIZE	25T						30W			30T					
	Half		Full		Double		Half	Full	Double	Half		Full		Double	
Airflow (cfm) at 500 fpm	12,335						15,174			14,852					
Total Face Area (sq ft)	24.7						30.3			29.7					
	Upper	Lower	Upper	Lower	Upper	Lower				Upper	Lower	Upper	Lower	Upper	Lower
Tubes in Face	28	30	28	30	28	30	38	38	38	28	30	28	30	28	30
Tube Length (in.)	49	49	49	49	49	49	92	92	92	59	59	59	59	59	59
No. of Circuits - Total	14	15	28	30	56	60	19	38	76	14	15	28	30	56	60
<b>4-Row Coil</b>															
<b>Face Split Coils</b>															
No. of TXVs	2	2	2	2	—	—	2	2	—	2	2	2	2	—	—
Suction Connections (in. OD)	1 <sup>1</sup> / <sub>8</sub>	1 <sup>1</sup> / <sub>8</sub>	1 <sup>5</sup> / <sub>8</sub>	1 <sup>5</sup> / <sub>8</sub>	—	—	1 <sup>3</sup> / <sub>8</sub>	1 <sup>5</sup> / <sub>8</sub>	—	1 <sup>1</sup> / <sub>8</sub>	1 <sup>1</sup> / <sub>8</sub>	1 <sup>5</sup> / <sub>8</sub>	1 <sup>5</sup> / <sub>8</sub>	—	—
Distributor Connections (in. OD)	7 <sup>7</sup> / <sub>8</sub>	7 <sup>7</sup> / <sub>8</sub>	1 <sup>3</sup> / <sub>8</sub>	1 <sup>3</sup> / <sub>8</sub>	—	—	1 <sup>1</sup> / <sub>8</sub>	1 <sup>3</sup> / <sub>8</sub>	—	7 <sup>7</sup> / <sub>8</sub>	7 <sup>7</sup> / <sub>8</sub>	1 <sup>3</sup> / <sub>8</sub>	1 <sup>3</sup> / <sub>8</sub>	—	—
Distributor Nozzle Size*	G-6	G-8/G-6	C-15	C-15	—	—	E-10/E-8	C-20	—	G-8/G-6	G-8/G-6	C-15	C-15	—	—
<b>Intertwined Row Split Coils</b>															
No. of TXVs	2	2	2	2	—	—	—	—	—	2	2	2	2	—	—
Suction Connections (in. OD)	1 <sup>1</sup> / <sub>8</sub>	1 <sup>1</sup> / <sub>8</sub>	1 <sup>5</sup> / <sub>8</sub>	1 <sup>5</sup> / <sub>8</sub>	—	—	1 <sup>3</sup> / <sub>8</sub>	1 <sup>5</sup> / <sub>8</sub>	—	1 <sup>1</sup> / <sub>8</sub>	1 <sup>1</sup> / <sub>8</sub>	1 <sup>5</sup> / <sub>8</sub>	1 <sup>5</sup> / <sub>8</sub>	—	—
Distributor Connections (in. OD)	7 <sup>7</sup> / <sub>8</sub>	7 <sup>7</sup> / <sub>8</sub>	1 <sup>3</sup> / <sub>8</sub>	1 <sup>3</sup> / <sub>8</sub>	—	—	1 <sup>1</sup> / <sub>8</sub>	1 <sup>3</sup> / <sub>8</sub>	—	7 <sup>7</sup> / <sub>8</sub>	7 <sup>7</sup> / <sub>8</sub>	1 <sup>3</sup> / <sub>8</sub>	1 <sup>3</sup> / <sub>8</sub>	—	—
Distributor Nozzle Size*	G-6	G-8/G-6	C-15	C-15	—	—	E-10/E-8	C-20	—	G-8/G-6	G-8/G-6	C-15	C-15	—	—
<b>Single-Circuit Coils</b>															
No. of TXVs	—	—	—	—	—	—	—	—	—	—	—	—	—	—	—
Suction Connections (in. OD)	—	—	—	—	—	—	—	—	—	—	—	—	—	—	—
Distributor Connections (in. OD)	—	—	—	—	—	—	—	—	—	—	—	—	—	—	—
Distributor Nozzle Size	—	—	—	—	—	—	—	—	—	—	—	—	—	—	—
<b>6-Row Coil</b>															
<b>Face Split Coils</b>															
No. of TXVs	2	2	2	2	—	—	2	2	—	2	2	2	2	—	—
Suction Connections (in. OD)	1 <sup>1</sup> / <sub>8</sub>	1 <sup>1</sup> / <sub>8</sub>	1 <sup>5</sup> / <sub>8</sub>	1 <sup>5</sup> / <sub>8</sub>	—	—	1 <sup>3</sup> / <sub>8</sub>	1 <sup>5</sup> / <sub>8</sub>	—	1 <sup>1</sup> / <sub>8</sub>	1 <sup>1</sup> / <sub>8</sub>	1 <sup>5</sup> / <sub>8</sub>	1 <sup>5</sup> / <sub>8</sub>	—	—
Distributor Connections (in. OD)	7 <sup>7</sup> / <sub>8</sub>	7 <sup>7</sup> / <sub>8</sub>	1 <sup>3</sup> / <sub>8</sub>	1 <sup>3</sup> / <sub>8</sub>	—	—	1 <sup>1</sup> / <sub>8</sub>	1 <sup>3</sup> / <sub>8</sub>	—	7 <sup>7</sup> / <sub>8</sub>	7 <sup>7</sup> / <sub>8</sub>	1 <sup>3</sup> / <sub>8</sub>	1 <sup>3</sup> / <sub>8</sub>	—	—
Distributor Nozzle Size*	G-6	G-8/G-6	C-15	C-15	—	—	E-10/E-8	C-20	—	G-8/G-6	G-8/G-6	C-15	C-15	—	—
<b>Intertwined Row Split Coils</b>															
No. of TXVs	2	2	2	2	—	—	—	—	—	2	2	2	2	—	—
Suction Connections (in. OD)	1 <sup>1</sup> / <sub>8</sub>	1 <sup>1</sup> / <sub>8</sub>	1 <sup>5</sup> / <sub>8</sub>	1 <sup>5</sup> / <sub>8</sub>	—	—	1 <sup>3</sup> / <sub>8</sub>	1 <sup>5</sup> / <sub>8</sub>	—	1 <sup>1</sup> / <sub>8</sub>	1 <sup>1</sup> / <sub>8</sub>	1 <sup>5</sup> / <sub>8</sub>	1 <sup>5</sup> / <sub>8</sub>	—	—
Distributor Connections (in. OD)	7 <sup>7</sup> / <sub>8</sub>	7 <sup>7</sup> / <sub>8</sub>	1 <sup>3</sup> / <sub>8</sub>	1 <sup>3</sup> / <sub>8</sub>	—	—	1 <sup>1</sup> / <sub>8</sub>	1 <sup>3</sup> / <sub>8</sub>	—	7 <sup>7</sup> / <sub>8</sub>	7 <sup>7</sup> / <sub>8</sub>	1 <sup>3</sup> / <sub>8</sub>	1 <sup>3</sup> / <sub>8</sub>	—	—
Distributor Nozzle Size*	G-6	G-8/G-6	C-15	C-15	—	—	E-10/E-8	C-20	—	G-8/G-6	G-8/G-6	C-15	C-15	—	—
<b>Single-Circuit Coils</b>															
No. of TXVs	—	—	—	—	—	—	—	—	—	—	—	—	—	—	—
Suction Connections (in. OD)	—	—	—	—	—	—	—	—	—	—	—	—	—	—	—
Distributor Connections (in. OD)	—	—	—	—	—	—	—	—	—	—	—	—	—	—	—
Distributor Nozzle Size	—	—	—	—	—	—	—	—	—	—	—	—	—	—	—
<b>8-Row Coil</b>															
<b>Face Split Coils</b>															
No. of TXVs	2	2	2	2	4	4	2	2	4	2	2	2	2	4	4
Suction Connections (in. OD)	1 <sup>1</sup> / <sub>8</sub>	1 <sup>5</sup> / <sub>8</sub>	1 <sup>5</sup> / <sub>8</sub>	1 <sup>5</sup> / <sub>8</sub>	1 <sup>5</sup> / <sub>8</sub>	1 <sup>5</sup> / <sub>8</sub>	1 <sup>3</sup> / <sub>8</sub>	1 <sup>5</sup> / <sub>8</sub>	1 <sup>5</sup> / <sub>8</sub>	1 <sup>1</sup> / <sub>8</sub>	1 <sup>1</sup> / <sub>8</sub>	1 <sup>5</sup> / <sub>8</sub>	1 <sup>5</sup> / <sub>8</sub>	1 <sup>5</sup> / <sub>8</sub>	1 <sup>5</sup> / <sub>8</sub>
Distributor Connections (in. OD)	7 <sup>7</sup> / <sub>8</sub>	7 <sup>7</sup> / <sub>8</sub>	1 <sup>3</sup> / <sub>8</sub>	1 <sup>3</sup> / <sub>8</sub>	1 <sup>3</sup> / <sub>8</sub>	1 <sup>3</sup> / <sub>8</sub>	1 <sup>1</sup> / <sub>8</sub>	1 <sup>3</sup> / <sub>8</sub>	1 <sup>3</sup> / <sub>8</sub>	7 <sup>7</sup> / <sub>8</sub>	7 <sup>7</sup> / <sub>8</sub>	1 <sup>3</sup> / <sub>8</sub>	1 <sup>3</sup> / <sub>8</sub>	1 <sup>3</sup> / <sub>8</sub>	1 <sup>3</sup> / <sub>8</sub>
Distributor Nozzle Size*	G-6	G-8/G-6	C-15	C-15	C-15	C-15	E-10/E-8	C-20	C-20	G-8/G-6	G-8/G-6	C-15	C-15	C-15	C-15
<b>Intertwined Row Split Coils</b>															
No. of TXVs	2	2	2	2	4	4	2	2	2	2	2	2	2	4	4
Suction Connections (in. OD)	1 <sup>1</sup> / <sub>8</sub>	1 <sup>1</sup> / <sub>8</sub>	1 <sup>5</sup> / <sub>8</sub>	1 <sup>5</sup> / <sub>8</sub>	1 <sup>5</sup> / <sub>8</sub>	1 <sup>5</sup> / <sub>8</sub>	1 <sup>3</sup> / <sub>8</sub>	1 <sup>5</sup> / <sub>8</sub>	1 <sup>5</sup> / <sub>8</sub>	1 <sup>1</sup> / <sub>8</sub>	1 <sup>1</sup> / <sub>8</sub>	1 <sup>5</sup> / <sub>8</sub>	1 <sup>5</sup> / <sub>8</sub>	1 <sup>5</sup> / <sub>8</sub>	1 <sup>5</sup> / <sub>8</sub>
Distributor Connections (in. OD)	7 <sup>7</sup> / <sub>8</sub>	7 <sup>7</sup> / <sub>8</sub>	1 <sup>3</sup> / <sub>8</sub>	1 <sup>3</sup> / <sub>8</sub>	1 <sup>3</sup> / <sub>8</sub>	1 <sup>3</sup> / <sub>8</sub>	1 <sup>1</sup> / <sub>8</sub>	1 <sup>3</sup> / <sub>8</sub>	1 <sup>3</sup> / <sub>8</sub>	7 <sup>7</sup> / <sub>8</sub>	7 <sup>7</sup> / <sub>8</sub>	1 <sup>3</sup> / <sub>8</sub>	1 <sup>3</sup> / <sub>8</sub>	1 <sup>3</sup> / <sub>8</sub>	1 <sup>3</sup> / <sub>8</sub>
Distributor Nozzle Size*	G-6	G-8/G-6	C-15	C-15	C-15	C-15	E-10/E-8	C-20	C-20	G-8/G-6	G-8/G-6	C-15	C-15	C-15	C-15
<b>Single-Circuit Coils</b>															
No. of TXVs	—	—	—	—	—	—	—	—	—	—	—	—	—	—	—
Suction Connections (in. OD)	—	—	—	—	—	—	—	—	—	—	—	—	—	—	—
Distributor Connections (in. OD)	—	—	—	—	—	—	—	—	—	—	—	—	—	—	—
Distributor Nozzle Size	—	—	—	—	—	—	—	—	—	—	—	—	—	—	—

**LEGEND**

**TXV** — Thermostatic Expansion Valve (Field Supplied)

\*When 2 nozzle sizes are listed, the smaller nozzle should be located on the upper distributor.

NOTE: Factory-supplied distributors have factory-selected nozzle sizes as shown. If necessary, replace factory-supplied nozzles with field-supplied and field-installed nozzles. Consult **AHUBuilder®** software selection program for correct nozzle selection.



→ DIRECT-EXPANSION CIRCUITING DATA (cont)  
LARGE FACE AREA COILS (cont)

CIRCUITING TYPE	39M UNIT SIZE		35T				36W		37T					
	Half		Full		Double		Full	Double	Half		Full		Double	
Airflow (cfm) at 500 fpm			17.448				18.333		18.950					
Total Face Area (sq ft)			34.9				36.7		37.9					
	Upper	Lower	Upper	Lower	Upper	Lower			Upper	Lower	Upper	Lower	Upper	Lower
Tubes in Face	30	30	30	30	30	30	44	44	36	38	36	38	36	38
Tube Length (in.)	67	67	67	67	67	67	96	96	59	59	59	59	59	59
No. of Circuits - Total	15	15	30	30	60	60	44	88	18	19	36	38	72	76
<b>4-Row Coil</b>														
<b>Face Split Coils</b>														
No. of TXVs	2	2	2	2	—	—	4	—	2	2	2	2	—	—
Suction Connections (in. OD)	1 <sup>1</sup> / <sub>8</sub>	1 <sup>1</sup> / <sub>8</sub>	1 <sup>5</sup> / <sub>8</sub>	1 <sup>5</sup> / <sub>8</sub>	—	—	1 <sup>3</sup> / <sub>8</sub>	—	1 <sup>1</sup> / <sub>8</sub>	1 <sup>3</sup> / <sub>8</sub>	1 <sup>5</sup> / <sub>8</sub>	1 <sup>5</sup> / <sub>8</sub>	—	—
Distributor Connections (in. OD)	7 <sup>7</sup> / <sub>8</sub>	7 <sup>7</sup> / <sub>8</sub>	1 <sup>3</sup> / <sub>8</sub>	1 <sup>3</sup> / <sub>8</sub>	—	—	1 <sup>1</sup> / <sub>8</sub>	—	1 <sup>1</sup> / <sub>8</sub>	1 <sup>1</sup> / <sub>8</sub>	1 <sup>3</sup> / <sub>8</sub>	1 <sup>3</sup> / <sub>8</sub>	—	—
Distributor Nozzle Size*	G-8/G-6	G-8/G-6	C-15	C-15	—	—	E-12	—	E-8	E-10/E-8	C-17	C-20	—	—
<b>Intertwined Row Split Coils</b>														
No. of TXVs	2	2	2	2	—	—	4	—	2	2	2	2	—	—
Suction Connections (in. OD)	1 <sup>1</sup> / <sub>8</sub>	1 <sup>1</sup> / <sub>8</sub>	1 <sup>5</sup> / <sub>8</sub>	1 <sup>5</sup> / <sub>8</sub>	—	—	1 <sup>3</sup> / <sub>8</sub>	—	1 <sup>1</sup> / <sub>8</sub>	1 <sup>3</sup> / <sub>8</sub>	1 <sup>5</sup> / <sub>8</sub>	1 <sup>5</sup> / <sub>8</sub>	—	—
Distributor Connections (in. OD)	7 <sup>7</sup> / <sub>8</sub>	7 <sup>7</sup> / <sub>8</sub>	1 <sup>3</sup> / <sub>8</sub>	1 <sup>3</sup> / <sub>8</sub>	—	—	1 <sup>1</sup> / <sub>8</sub>	—	1 <sup>1</sup> / <sub>8</sub>	1 <sup>1</sup> / <sub>8</sub>	1 <sup>3</sup> / <sub>8</sub>	1 <sup>3</sup> / <sub>8</sub>	—	—
Distributor Nozzle Size*	G-8/G-6	G-8/G-6	C-15	C-15	—	—	E-12	—	E-8	E-10/E-8	C-17	C-20	—	—
<b>Single-Circuit Coils</b>														
No. of TXVs	—	—	—	—	—	—	—	—	—	—	—	—	—	—
Suction Connections (in. OD)	—	—	—	—	—	—	—	—	—	—	—	—	—	—
Distributor Connections (in. OD)	—	—	—	—	—	—	—	—	—	—	—	—	—	—
Distributor Nozzle Size	—	—	—	—	—	—	—	—	—	—	—	—	—	—
<b>6-Row Coil</b>														
<b>Face Split Coils</b>														
No. of TXVs	2	2	2	2	—	—	4	—	2	2	2	2	—	—
Suction Connections (in. OD)	1 <sup>1</sup> / <sub>8</sub>	1 <sup>1</sup> / <sub>8</sub>	1 <sup>5</sup> / <sub>8</sub>	1 <sup>5</sup> / <sub>8</sub>	—	—	1 <sup>3</sup> / <sub>8</sub>	—	1 <sup>3</sup> / <sub>8</sub>	1 <sup>3</sup> / <sub>8</sub>	1 <sup>5</sup> / <sub>8</sub>	1 <sup>5</sup> / <sub>8</sub>	—	—
Distributor Connections (in. OD)	7 <sup>7</sup> / <sub>8</sub>	7 <sup>7</sup> / <sub>8</sub>	1 <sup>3</sup> / <sub>8</sub>	1 <sup>3</sup> / <sub>8</sub>	—	—	1 <sup>1</sup> / <sub>8</sub>	—	1 <sup>1</sup> / <sub>8</sub>	1 <sup>1</sup> / <sub>8</sub>	1 <sup>3</sup> / <sub>8</sub>	1 <sup>3</sup> / <sub>8</sub>	—	—
Distributor Nozzle Size*	G-8/G-6	G-8/G-6	C-15	C-15	—	—	E-12	—	E-8	E-10/E-8	C-17	C-20	—	—
<b>Intertwined Row Split Coils</b>														
No. of TXVs	2	2	2	2	—	—	4	—	2	2	2	2	—	—
Suction Connections (in. OD)	1 <sup>1</sup> / <sub>8</sub>	1 <sup>1</sup> / <sub>8</sub>	1 <sup>5</sup> / <sub>8</sub>	1 <sup>5</sup> / <sub>8</sub>	—	—	1 <sup>3</sup> / <sub>8</sub>	—	1 <sup>3</sup> / <sub>8</sub>	1 <sup>3</sup> / <sub>8</sub>	1 <sup>5</sup> / <sub>8</sub>	1 <sup>5</sup> / <sub>8</sub>	—	—
Distributor Connections (in. OD)	7 <sup>7</sup> / <sub>8</sub>	7 <sup>7</sup> / <sub>8</sub>	1 <sup>3</sup> / <sub>8</sub>	1 <sup>3</sup> / <sub>8</sub>	—	—	1 <sup>1</sup> / <sub>8</sub>	—	1 <sup>1</sup> / <sub>8</sub>	1 <sup>1</sup> / <sub>8</sub>	1 <sup>3</sup> / <sub>8</sub>	1 <sup>3</sup> / <sub>8</sub>	—	—
Distributor Nozzle Size*	G-8/G-6	G-8/G-6	C-15	C-15	—	—	E-12	—	E-8	E-10/E-8	C-17	C-20	—	—
<b>Single-Circuit Coils</b>														
No. of TXVs	—	—	—	—	—	—	—	—	—	—	—	—	—	—
Suction Connections (in. OD)	—	—	—	—	—	—	—	—	—	—	—	—	—	—
Distributor Connections (in. OD)	—	—	—	—	—	—	—	—	—	—	—	—	—	—
Distributor Nozzle Size	—	—	—	—	—	—	—	—	—	—	—	—	—	—
<b>8-Row Coil</b>														
<b>Face Split Coils</b>														
No. of TXVs	2	2	2	2	4	4	4	—	2	2	2	2	4	4
Suction Connections (in. OD)	1 <sup>1</sup> / <sub>8</sub>	1 <sup>1</sup> / <sub>8</sub>	1 <sup>5</sup> / <sub>8</sub>	1 <sup>5</sup> / <sub>8</sub>	1 <sup>5</sup> / <sub>8</sub>	1 <sup>5</sup> / <sub>8</sub>	1 <sup>3</sup> / <sub>8</sub>	—	1 <sup>3</sup> / <sub>8</sub>	1 <sup>3</sup> / <sub>8</sub>	1 <sup>5</sup> / <sub>8</sub>	1 <sup>5</sup> / <sub>8</sub>	1 <sup>5</sup> / <sub>8</sub>	1 <sup>5</sup> / <sub>8</sub>
Distributor Connections (in. OD)	7 <sup>7</sup> / <sub>8</sub>	7 <sup>7</sup> / <sub>8</sub>	1 <sup>3</sup> / <sub>8</sub>	1 <sup>3</sup> / <sub>8</sub>	1 <sup>3</sup> / <sub>8</sub>	1 <sup>3</sup> / <sub>8</sub>	1 <sup>1</sup> / <sub>8</sub>	—	1 <sup>1</sup> / <sub>8</sub>	1 <sup>1</sup> / <sub>8</sub>	1 <sup>3</sup> / <sub>8</sub>	1 <sup>3</sup> / <sub>8</sub>	1 <sup>3</sup> / <sub>8</sub>	1 <sup>3</sup> / <sub>8</sub>
Distributor Nozzle Size*	G-8/G-6	G-8/G-6	C-15	C-15	C-15	C-15	E-12	—	E-8	E-10/E-8	C-17	C-20	C-17	C-20
<b>Intertwined Row Split Coils</b>														
No. of TXVs	2	2	2	2	4	4	4	—	2	2	2	2	4	4
Suction Connections (in. OD)	1 <sup>1</sup> / <sub>8</sub>	1 <sup>1</sup> / <sub>8</sub>	1 <sup>5</sup> / <sub>8</sub>	1 <sup>5</sup> / <sub>8</sub>	1 <sup>5</sup> / <sub>8</sub>	1 <sup>5</sup> / <sub>8</sub>	1 <sup>3</sup> / <sub>8</sub>	—	1 <sup>3</sup> / <sub>8</sub>	1 <sup>3</sup> / <sub>8</sub>	1 <sup>5</sup> / <sub>8</sub>	1 <sup>5</sup> / <sub>8</sub>	1 <sup>5</sup> / <sub>8</sub>	1 <sup>5</sup> / <sub>8</sub>
Distributor Connections (in. OD)	7 <sup>7</sup> / <sub>8</sub>	7 <sup>7</sup> / <sub>8</sub>	1 <sup>3</sup> / <sub>8</sub>	1 <sup>3</sup> / <sub>8</sub>	1 <sup>3</sup> / <sub>8</sub>	1 <sup>3</sup> / <sub>8</sub>	1 <sup>1</sup> / <sub>8</sub>	—	1 <sup>1</sup> / <sub>8</sub>	1 <sup>1</sup> / <sub>8</sub>	1 <sup>3</sup> / <sub>8</sub>	1 <sup>3</sup> / <sub>8</sub>	1 <sup>3</sup> / <sub>8</sub>	1 <sup>3</sup> / <sub>8</sub>
Distributor Nozzle Size*	G-8/G-6	G-8/G-6	C-15	C-15	C-15	C-15	E-12	—	E-8	E-10/E-8	C-17	C-20	C-17	C-20
<b>Single-Circuit Coils</b>														
No. of TXVs	—	—	—	—	—	—	—	—	—	—	—	—	—	—
Suction Connections (in. OD)	—	—	—	—	—	—	—	—	—	—	—	—	—	—
Distributor Connections (in. OD)	—	—	—	—	—	—	—	—	—	—	—	—	—	—
Distributor Nozzle Size	—	—	—	—	—	—	—	—	—	—	—	—	—	—

LEGEND

TXV — Thermostatic Expansion Valve (Field Supplied)

\*When 2 nozzle sizes are listed, the smaller nozzle should be located on the upper distributor.

NOTE: Factory-supplied distributors have factory-selected nozzle sizes as shown. If necessary, replace factory-supplied nozzles with field-supplied and field-installed nozzles. Consult AHUBuilder® software selection program for correct nozzle selection.

# Physical data (cont)



## DIRECT-EXPANSION CIRCUITING DATA (cont) LARGE FACE AREA COILS (cont)

CIRCUITING TYPE	40W				50W				61W				72W			
	Full		Double		Full		Double		Full		Double		Full		Double	
Airflow (cfm) at 500 fpm	20,000				25,278				30,694				36,224			
Total Face Area (sq ft)	40.0				50.6				61.4				72.4			
	Upper	Lower	Upper	Lower	Upper	Lower	Upper	Lower	Upper	Lower	Upper	Lower	Upper	Lower	Upper	Lower
Tubes in Face	24	24	24	24	28	28	28	28	34	34	34	34	38	40	38	40
Tube Length (in.)	96	96	96	96	104	104	104	104	104	104	104	104	107	107	107	107
No. of Circuits - Total	24	24	48	48	28	28	56	56	34	34	68	68	38	40	76	80
<b>4-Row Coil</b>																
<b>Face Split Coils</b>																
No. of TXVs	2	2	—	—	2	2	—	—	2	2	—	—	2	4	—	—
Suction Connections (in. OD)	1 <sup>3</sup> / <sub>8</sub>	1 <sup>3</sup> / <sub>8</sub>	—	—	1 <sup>5</sup> / <sub>8</sub>	1 <sup>5</sup> / <sub>8</sub>	—	—	1 <sup>5</sup> / <sub>8</sub>	1 <sup>5</sup> / <sub>8</sub>	—	—	1 <sup>5</sup> / <sub>8</sub>	1 <sup>3</sup> / <sub>8</sub>	—	—
Distributor Connections (in. OD)	1 <sup>3</sup> / <sub>8</sub>	1 <sup>3</sup> / <sub>8</sub>	—	—	1 <sup>3</sup> / <sub>8</sub>	1 <sup>3</sup> / <sub>8</sub>	—	—	1 <sup>3</sup> / <sub>8</sub>	1 <sup>3</sup> / <sub>8</sub>	—	—	1 <sup>3</sup> / <sub>8</sub>	1 <sup>1</sup> / <sub>8</sub>	—	—
Distributor Nozzle Size*	C-12	C-12	—	—	C-15	C-15	—	—	C-17	C-17	—	—	C-20	E-10	—	—
<b>Intertwined Row Split Coils</b>																
No. of TXVs	2	2	—	—	2	2	—	—	2	2	—	—	2	4	—	—
Suction Connections (in. OD)	1 <sup>3</sup> / <sub>8</sub>	1 <sup>3</sup> / <sub>8</sub>	—	—	1 <sup>5</sup> / <sub>8</sub>	1 <sup>5</sup> / <sub>8</sub>	—	—	1 <sup>5</sup> / <sub>8</sub>	1 <sup>5</sup> / <sub>8</sub>	—	—	1 <sup>5</sup> / <sub>8</sub>	1 <sup>3</sup> / <sub>8</sub>	—	—
Distributor Connections (in. OD)	1 <sup>3</sup> / <sub>8</sub>	1 <sup>3</sup> / <sub>8</sub>	—	—	1 <sup>3</sup> / <sub>8</sub>	1 <sup>3</sup> / <sub>8</sub>	—	—	1 <sup>3</sup> / <sub>8</sub>	1 <sup>3</sup> / <sub>8</sub>	—	—	1 <sup>3</sup> / <sub>8</sub>	1 <sup>1</sup> / <sub>8</sub>	—	—
Distributor Nozzle Size*	C-12	C-12	—	—	C-15	C-15	—	—	C-17	C-17	—	—	C-20	E-10	—	—
<b>Single-Circuit Coils</b>																
No. of TXVs	—	—	—	—	—	—	—	—	—	—	—	—	—	—	—	—
Suction Connections (in. OD)	—	—	—	—	—	—	—	—	—	—	—	—	—	—	—	—
Distributor Connections (in. OD)	—	—	—	—	—	—	—	—	—	—	—	—	—	—	—	—
Distributor Nozzle Size	—	—	—	—	—	—	—	—	—	—	—	—	—	—	—	—
<b>6-Row Coil</b>																
<b>Face Split Coils</b>																
No. of TXVs	2	2	—	—	2	2	—	—	2	2	—	—	2	4	—	—
Suction Connections (in. OD)	1 <sup>3</sup> / <sub>8</sub>	1 <sup>3</sup> / <sub>8</sub>	—	—	1 <sup>5</sup> / <sub>8</sub>	1 <sup>5</sup> / <sub>8</sub>	—	—	1 <sup>5</sup> / <sub>8</sub>	1 <sup>5</sup> / <sub>8</sub>	—	—	1 <sup>5</sup> / <sub>8</sub>	1 <sup>3</sup> / <sub>8</sub>	—	—
Distributor Connections (in. OD)	1 <sup>3</sup> / <sub>8</sub>	1 <sup>3</sup> / <sub>8</sub>	—	—	1 <sup>3</sup> / <sub>8</sub>	1 <sup>3</sup> / <sub>8</sub>	—	—	1 <sup>3</sup> / <sub>8</sub>	1 <sup>3</sup> / <sub>8</sub>	—	—	1 <sup>3</sup> / <sub>8</sub>	1 <sup>1</sup> / <sub>8</sub>	—	—
Distributor Nozzle Size*	C-12	C-12	—	—	C-15	C-15	—	—	C-17	C-17	—	—	C-20	E-10	—	—
<b>Intertwined Row Split Coils</b>																
No. of TXVs	2	2	—	—	2	2	—	—	2	2	—	—	2	4	—	—
Suction Connections (in. OD)	1 <sup>3</sup> / <sub>8</sub>	1 <sup>3</sup> / <sub>8</sub>	—	—	1 <sup>5</sup> / <sub>8</sub>	1 <sup>5</sup> / <sub>8</sub>	—	—	1 <sup>5</sup> / <sub>8</sub>	1 <sup>5</sup> / <sub>8</sub>	—	—	1 <sup>5</sup> / <sub>8</sub>	1 <sup>3</sup> / <sub>8</sub>	—	—
Distributor Connections (in. OD)	1 <sup>3</sup> / <sub>8</sub>	1 <sup>3</sup> / <sub>8</sub>	—	—	1 <sup>3</sup> / <sub>8</sub>	1 <sup>3</sup> / <sub>8</sub>	—	—	1 <sup>3</sup> / <sub>8</sub>	1 <sup>3</sup> / <sub>8</sub>	—	—	1 <sup>3</sup> / <sub>8</sub>	1 <sup>1</sup> / <sub>8</sub>	—	—
Distributor Nozzle Size*	C-12	C-12	—	—	C-15	C-15	—	—	C-17	C-17	—	—	C-20	E-10	—	—
<b>Single-Circuit Coils</b>																
No. of TXVs	—	—	—	—	—	—	—	—	—	—	—	—	—	—	—	—
Suction Connections (in. OD)	—	—	—	—	—	—	—	—	—	—	—	—	—	—	—	—
Distributor Connections (in. OD)	—	—	—	—	—	—	—	—	—	—	—	—	—	—	—	—
Distributor Nozzle Size	—	—	—	—	—	—	—	—	—	—	—	—	—	—	—	—
<b>8-Row Coil</b>																
<b>Face Split Coils</b>																
No. of TXVs	2	2	4	4	2	2	4	4	2	2	4	4	2	4	4	8
Suction Connections (in. OD)	1 <sup>3</sup> / <sub>8</sub>	1 <sup>3</sup> / <sub>8</sub>	1 <sup>3</sup> / <sub>8</sub>	1 <sup>3</sup> / <sub>8</sub>	1 <sup>5</sup> / <sub>8</sub>	1 <sup>5</sup> / <sub>8</sub>	1 <sup>5</sup> / <sub>8</sub>	1 <sup>5</sup> / <sub>8</sub>	1 <sup>5</sup> / <sub>8</sub>	1 <sup>5</sup> / <sub>8</sub>	1 <sup>5</sup> / <sub>8</sub>	1 <sup>5</sup> / <sub>8</sub>	1 <sup>5</sup> / <sub>8</sub>	1 <sup>3</sup> / <sub>8</sub>	1 <sup>5</sup> / <sub>8</sub>	1 <sup>3</sup> / <sub>8</sub>
Distributor Connections (in. OD)	1 <sup>3</sup> / <sub>8</sub>	1 <sup>3</sup> / <sub>8</sub>	1 <sup>3</sup> / <sub>8</sub>	1 <sup>3</sup> / <sub>8</sub>	1 <sup>3</sup> / <sub>8</sub>	1 <sup>3</sup> / <sub>8</sub>	1 <sup>3</sup> / <sub>8</sub>	1 <sup>3</sup> / <sub>8</sub>	1 <sup>3</sup> / <sub>8</sub>	1 <sup>3</sup> / <sub>8</sub>	1 <sup>3</sup> / <sub>8</sub>	1 <sup>3</sup> / <sub>8</sub>	1 <sup>3</sup> / <sub>8</sub>	1 <sup>1</sup> / <sub>8</sub>	1 <sup>3</sup> / <sub>8</sub>	1 <sup>1</sup> / <sub>8</sub>
Distributor Nozzle Size*	C-12	C-12	C-12	C-12	C-15	C-15	C-15	C-15	C-17	C-17	C-17	C-17	C-20	E-10	C-20	E-10
<b>Intertwined Row Split Coils</b>																
No. of TXVs	2	2	4	4	2	2	4	4	2	2	4	4	2	4	4	8
Suction Connections (in. OD)	1 <sup>3</sup> / <sub>8</sub>	1 <sup>3</sup> / <sub>8</sub>	1 <sup>3</sup> / <sub>8</sub>	1 <sup>3</sup> / <sub>8</sub>	1 <sup>5</sup> / <sub>8</sub>	1 <sup>5</sup> / <sub>8</sub>	1 <sup>5</sup> / <sub>8</sub>	1 <sup>5</sup> / <sub>8</sub>	1 <sup>5</sup> / <sub>8</sub>	1 <sup>5</sup> / <sub>8</sub>	1 <sup>5</sup> / <sub>8</sub>	1 <sup>5</sup> / <sub>8</sub>	1 <sup>5</sup> / <sub>8</sub>	1 <sup>3</sup> / <sub>8</sub>	1 <sup>5</sup> / <sub>8</sub>	1 <sup>3</sup> / <sub>8</sub>
Distributor Connections (in. OD)	1 <sup>3</sup> / <sub>8</sub>	1 <sup>3</sup> / <sub>8</sub>	1 <sup>3</sup> / <sub>8</sub>	1 <sup>3</sup> / <sub>8</sub>	1 <sup>3</sup> / <sub>8</sub>	1 <sup>3</sup> / <sub>8</sub>	1 <sup>3</sup> / <sub>8</sub>	1 <sup>3</sup> / <sub>8</sub>	1 <sup>3</sup> / <sub>8</sub>	1 <sup>3</sup> / <sub>8</sub>	1 <sup>3</sup> / <sub>8</sub>	1 <sup>3</sup> / <sub>8</sub>	1 <sup>3</sup> / <sub>8</sub>	1 <sup>1</sup> / <sub>8</sub>	1 <sup>3</sup> / <sub>8</sub>	1 <sup>1</sup> / <sub>8</sub>
Distributor Nozzle Size*	C-12	C-12	C-12	C-12	C-15	C-15	C-15	C-15	C-17	C-17	C-17	C-17	C-20	E-10	C-20	E-10
<b>Single-Circuit Coils</b>																
No. of TXVs	—	—	—	—	—	—	—	—	—	—	—	—	—	—	—	—
Suction Connections (in. OD)	—	—	—	—	—	—	—	—	—	—	—	—	—	—	—	—
Distributor Connections (in. OD)	—	—	—	—	—	—	—	—	—	—	—	—	—	—	—	—
Distributor Nozzle Size	—	—	—	—	—	—	—	—	—	—	—	—	—	—	—	—

**LEGEND**

**TXV** — Thermostatic Expansion Valve (Field Supplied)

\*When 2 nozzle sizes are listed, the smaller nozzle should be located on the upper distributor.

NOTE: Factory-supplied distributors have factory-selected nozzle sizes as shown. If necessary, replace factory-supplied nozzles with field-supplied and field-installed nozzles. Consult **AHUBuilder®** software selection program for correct nozzle selection.

### DIRECT-EXPANSION CIRCUITING DATA (cont) LARGE FACE AREA COILS (cont)

39M UNIT SIZE	85W				96W				110W			
	Full		Double		Full		Double		Full		Double	
<b>CIRCUITING TYPE</b>	46,656 85.3				48,125 96.3				55,000 110.0			
Airflow (cfm) at 500 fpm												
Total Face Area (sq ft)	Upper	Lower	Upper	Lower	Upper	Lower	Upper	Lower	Upper	Lower	Upper	Lower
Tubes in Face	38	40	38	40	44	44	44	44	44	44	44	44
Tube Length (in.)	126	126	126	126	126	126	126	126	144	144	144	144
No. of Circuits - Total	38	40	76	80	44	44	88	88	44	44	88	88
<b>4-Row Coil</b>												
<b>Face Split Coils</b>												
No. of TXVs	2	4	—	—	4	4	—	—	4	4	—	—
Suction Connections (in. OD)	1 <sup>5</sup> / <sub>8</sub>	1 <sup>3</sup> / <sub>8</sub>	—	—	1 <sup>3</sup> / <sub>8</sub>	1 <sup>3</sup> / <sub>8</sub>	—	—	1 <sup>3</sup> / <sub>8</sub>	1 <sup>3</sup> / <sub>8</sub>	—	—
Distributor Connections (in. OD)	1 <sup>3</sup> / <sub>8</sub>	1 <sup>1</sup> / <sub>8</sub>	—	—	1 <sup>1</sup> / <sub>8</sub>	1 <sup>1</sup> / <sub>8</sub>	—	—	1 <sup>1</sup> / <sub>8</sub>	1 <sup>1</sup> / <sub>8</sub>	—	—
Distributor Nozzle Size*	C-20	E-10	—	—	E-12	E-12	—	—	E-12	E-12	—	—
<b>Intertwined Row Split Coils</b>												
No. of TXVs	2	4	—	—	4	4	—	—	4	4	—	—
Suction Connections (in. OD)	1 <sup>5</sup> / <sub>8</sub>	1 <sup>3</sup> / <sub>8</sub>	—	—	1 <sup>3</sup> / <sub>8</sub>	1 <sup>3</sup> / <sub>8</sub>	—	—	1 <sup>3</sup> / <sub>8</sub>	1 <sup>3</sup> / <sub>8</sub>	—	—
Distributor Connections (in. OD)	1 <sup>3</sup> / <sub>8</sub>	1 <sup>1</sup> / <sub>8</sub>	—	—	1 <sup>1</sup> / <sub>8</sub>	1 <sup>1</sup> / <sub>8</sub>	—	—	1 <sup>1</sup> / <sub>8</sub>	1 <sup>1</sup> / <sub>8</sub>	—	—
Distributor Nozzle Size*	C-20	E-10	—	—	E-12	E-12	—	—	E-12	E-12	—	—
<b>Single-Circuit Coils</b>												
No. of TXVs	—	—	—	—	—	—	—	—	—	—	—	—
Suction Connections (in. OD)	—	—	—	—	—	—	—	—	—	—	—	—
Distributor Connections (in. OD)	—	—	—	—	—	—	—	—	—	—	—	—
Distributor Nozzle Size	—	—	—	—	—	—	—	—	—	—	—	—
<b>6-Row Coil</b>												
<b>Face Split Coils</b>												
No. of TXVs	2	4	—	—	4	4	—	—	4	4	—	—
Suction Connections (in. OD)	1 <sup>5</sup> / <sub>8</sub>	1 <sup>3</sup> / <sub>8</sub>	—	—	1 <sup>3</sup> / <sub>8</sub>	1 <sup>3</sup> / <sub>8</sub>	—	—	1 <sup>3</sup> / <sub>8</sub>	1 <sup>3</sup> / <sub>8</sub>	—	—
Distributor Connections (in. OD)	1 <sup>3</sup> / <sub>8</sub>	1 <sup>1</sup> / <sub>8</sub>	—	—	1 <sup>1</sup> / <sub>8</sub>	1 <sup>1</sup> / <sub>8</sub>	—	—	1 <sup>1</sup> / <sub>8</sub>	1 <sup>1</sup> / <sub>8</sub>	—	—
Distributor Nozzle Size*	C-20	E-10	—	—	E-12	E-12	—	—	E-12	E-12	—	—
<b>Intertwined Row Split Coils</b>												
No. of TXVs	2	4	—	—	4	4	—	—	4	4	—	—
Suction Connections (in. OD)	1 <sup>5</sup> / <sub>8</sub>	1 <sup>3</sup> / <sub>8</sub>	—	—	1 <sup>3</sup> / <sub>8</sub>	1 <sup>3</sup> / <sub>8</sub>	—	—	1 <sup>3</sup> / <sub>8</sub>	1 <sup>3</sup> / <sub>8</sub>	—	—
Distributor Connections (in. OD)	1 <sup>3</sup> / <sub>8</sub>	1 <sup>1</sup> / <sub>8</sub>	—	—	1 <sup>1</sup> / <sub>8</sub>	1 <sup>1</sup> / <sub>8</sub>	—	—	1 <sup>1</sup> / <sub>8</sub>	1 <sup>1</sup> / <sub>8</sub>	—	—
Distributor Nozzle Size*	C-20	E-10	—	—	E-12	E-12	—	—	E-12	E-12	—	—
<b>Single-Circuit Coils</b>												
No. of TXVs	—	—	—	—	—	—	—	—	—	—	—	—
Suction Connections (in. OD)	—	—	—	—	—	—	—	—	—	—	—	—
Distributor Connections (in. OD)	—	—	—	—	—	—	—	—	—	—	—	—
Distributor Nozzle Size	—	—	—	—	—	—	—	—	—	—	—	—
<b>8-Row Coil</b>												
<b>Face Split Coils</b>												
No. of TXVs	2	4	4	8	4	4	8	8	4	4	8	8
Suction Connections (in. OD)	1 <sup>5</sup> / <sub>8</sub>	1 <sup>3</sup> / <sub>8</sub>	1 <sup>5</sup> / <sub>8</sub>	1 <sup>3</sup> / <sub>8</sub>	1 <sup>3</sup> / <sub>8</sub>	1 <sup>3</sup> / <sub>8</sub>	1 <sup>3</sup> / <sub>8</sub>	1 <sup>3</sup> / <sub>8</sub>	1 <sup>3</sup> / <sub>8</sub>	1 <sup>3</sup> / <sub>8</sub>	1 <sup>3</sup> / <sub>8</sub>	1 <sup>3</sup> / <sub>8</sub>
Distributor Connections (in. OD)	1 <sup>3</sup> / <sub>8</sub>	1 <sup>1</sup> / <sub>8</sub>	1 <sup>3</sup> / <sub>8</sub>	1 <sup>1</sup> / <sub>8</sub>	1 <sup>1</sup> / <sub>8</sub>	1 <sup>1</sup> / <sub>8</sub>	1 <sup>1</sup> / <sub>8</sub>	1 <sup>1</sup> / <sub>8</sub>	1 <sup>1</sup> / <sub>8</sub>	1 <sup>1</sup> / <sub>8</sub>	1 <sup>1</sup> / <sub>8</sub>	1 <sup>1</sup> / <sub>8</sub>
Distributor Nozzle Size*	C-20	E-10	C-20	E-10	E-12	E-12	E-12	E-12	E-12	E-12	E-12	E-12
<b>Intertwined Row Split Coils</b>												
No. of TXVs	2	4	4	8	4	4	8	8	4	4	8	8
Suction Connections (in. OD)	1 <sup>5</sup> / <sub>8</sub>	1 <sup>3</sup> / <sub>8</sub>	1 <sup>5</sup> / <sub>8</sub>	1 <sup>3</sup> / <sub>8</sub>	1 <sup>3</sup> / <sub>8</sub>	1 <sup>3</sup> / <sub>8</sub>	1 <sup>3</sup> / <sub>8</sub>	1 <sup>3</sup> / <sub>8</sub>	1 <sup>3</sup> / <sub>8</sub>	1 <sup>3</sup> / <sub>8</sub>	1 <sup>3</sup> / <sub>8</sub>	1 <sup>3</sup> / <sub>8</sub>
Distributor Connections (in. OD)	1 <sup>3</sup> / <sub>8</sub>	1 <sup>1</sup> / <sub>8</sub>	1 <sup>3</sup> / <sub>8</sub>	1 <sup>1</sup> / <sub>8</sub>	1 <sup>1</sup> / <sub>8</sub>	1 <sup>1</sup> / <sub>8</sub>	1 <sup>1</sup> / <sub>8</sub>	1 <sup>1</sup> / <sub>8</sub>	1 <sup>1</sup> / <sub>8</sub>	1 <sup>1</sup> / <sub>8</sub>	1 <sup>1</sup> / <sub>8</sub>	1 <sup>1</sup> / <sub>8</sub>
Distributor Nozzle Size*	C-20	E-10	C-20	E-10	E-12	E-12	E-12	E-12	E-12	E-12	E-12	E-12
<b>Single-Circuit Coils</b>												
No. of TXVs	—	—	—	—	—	—	—	—	—	—	—	—
Suction Connections (in. OD)	—	—	—	—	—	—	—	—	—	—	—	—
Distributor Connections (in. OD)	—	—	—	—	—	—	—	—	—	—	—	—
Distributor Nozzle Size	—	—	—	—	—	—	—	—	—	—	—	—

**LEGEND**

TXV — Thermostatic Expansion Valve (Field Supplied)

\*When 2 nozzle sizes are listed, the smaller nozzle should be located on the upper distributor.

NOTE: Factory-supplied distributors have factory-selected nozzle sizes as shown. If necessary, replace factory-supplied nozzles with field-supplied and field-installed nozzles. Consult **AHUBuilder®** software selection program for correct nozzle selection.

# Physical data (cont)



## COIL DATA

39M UNIT SIZE	03W	06W	08W	10W	12W	14W	16T	17W	18T	21W	22TW	25W	25T
<b>1/2-in. CHILLED WATER/DIRECT EXPANSION</b>													
<b>Large Face Area</b>													
Nominal Capacity (cfm) at 500 fpm	1,736	2,951	3,819	4,965	6,319	7,170	7,587	8,464	8,898	10,720	11,016	12,205	12,335
Lower Coil Height (in.)	25	25	27.5	27.5	35	35	30	37.5	32.5	47.5	35	47.5	37.5
Upper Coil Height (in.)	N/A	N/A	N/A	N/A	N/A	N/A	27.5	N/A	30	N/A	32.5	N/A	35
Length (in.)	20	34	40	52	52	59	38	65	41	65	47	74	49
Total Face Area (sq ft)	3.5	5.9	7.6	9.9	12.6	14.3	15.2	16.9	17.8	21.4	22.0	24.4	24.7
<b>Medium Face Area</b>													
Nominal Capacity (cfm) at 500 fpm	1,215	2,066	2,778	3,611	4,965	6,146	5,938	6,771	7,474	9,028	8,976	10,278	9,358
Lower Coil Height (in.)	17.5	17.5	20	20	27.5	30	45	30	52.5	40	55	40	55
Upper Coil Height (in.)	N/A	N/A	N/A	N/A	N/A	N/A	N/A	N/A	N/A	N/A	N/A	N/A	N/A
Length (in.)	20	34	40	52	52	59	38	65	41	65	47	74	49
Total Face Area (sq ft)	2.4	4.1	5.6	7.2	9.9	12.3	11.9	13.5	14.9	18.1	18.0	20.6	18.7
<b>Bypass Face Area (Internal Chilled Water Only)</b>													
Nominal Capacity (cfm) at 500 fpm	1,042	1,771	2,431	3,160	4,514	5,122	4,948	6,207	5,694	7,899	6,936	8,993	8,082
Lower Coil Height (in.)	15	15	17.5	17.5	25	25	37.5	27.5	40	35	42.5	35	47.5
Upper Coil Height (in.)	N/A	N/A	N/A	N/A	N/A	N/A	N/A	N/A	N/A	N/A	N/A	N/A	N/A
Length (in.)	20	34	40	52	52	59	38	65	41	65	47	74	49
Total Face Area (sq ft)	2.1	3.5	4.9	6.3	9.0	10.2	15.2	12.4	11.4	15.8	13.9	18.0	16.2
<b>1/2-in. HOT WATER HEATING</b>													
<b>Large Face Area</b>													
Nominal Capacity (cfm) at 700 fpm	2,431	4,132	5,347	6,951	8,847	10,038	10,622	11,849	12,457	15,009	15,422	17,087	17,269
Lower Coil Height (in.)	25	25	27.5	27.5	35	35	30	37.5	32.5	47.5	35	47.5	37.5
Upper Coil Height (in.)	N/A	N/A	N/A	N/A	N/A	N/A	27.5	N/A	30	N/A	32.5	N/A	35
Length (in.)	20	34	40	52	52	59	38	65	41	65	47	74	49
Total Face Area (sq ft)	3.5	5.9	7.6	9.9	12.6	14.3	9.9	16.9	17.8	21.4	22.0	24.4	24.7
<b>Medium Face Area</b>													
Nominal Capacity (cfm) at 700 fpm	1,701	2,892	3,889	5,056	6,951	8,604	8,313	9,479	10,464	12,639	12,566	14,389	13,101
Lower Coil Height (in.)	17.5	17.5	20	20	27.5	30	45	30	52.5	40	55	40	55
Upper Coil Height (in.)	N/A	N/A	N/A	N/A	N/A	N/A	N/A	N/A	N/A	N/A	N/A	N/A	N/A
Length (in.)	20	34	40	52	52	59	38	65	41	65	47	74	49
Total Face Area (sq ft)	2.4	4.1	5.6	7.2	9.9	12.3	11.9	13.5	11.4	18.1	22.0	20.6	18.7
<b>Small Face Area</b>													
Nominal Capacity (cfm) at 700 fpm	—	2,479	2,917	3,792	4,424	5,019	5,542	6,319	6,477	7,109	7,425	8,094	7,741
Height (in.)	—	15	15	15	17.5	17.5	30	20	32.5	22.5	32.5	22.5	32.5
Length (in.)	—	34	40	52	52	59	38	65	41	65	47	74	49
Total Face Area (sq ft)	—	3.5	4.2	5.4	6.3	7.2	7.9	9.0	9.3	10.2	10.6	11.6	11.1
<b>Bypass Face Area (Internal)</b>													
Nominal Capacity (cfm) at 700 fpm	1,458	2,479	3,403	4,424	6,319	7,170	6,927	8,689	7,972	11,059	9,710	12,590	11,314
Lower Coil Height (in.)	15	15	17.5	17.5	25	25	37.5	27.5	40	35	42.5	35	47.5
Upper Coil Height (in.)	N/A	N/A	N/A	N/A	N/A	N/A	N/A	N/A	N/A	N/A	N/A	N/A	N/A
Length (in.)	20	34	40	52	52	59	38	65	41	65	47	74	49
Total Face Area (sq ft)	2.1	3.5	4.9	6.3	9.0	10.2	9.9	12.4	11.4	15.8	13.9	18.0	16.2
<b>5/8-in. STEAM HEATING</b>													
<b>Large Face Area</b>													
Nominal Capacity (cfm) at 700 fpm	2,333	3,967	5,250	6,825	8,342	9,465	6,096	11,375	7,175	14,219	10,281	16,188	10,719
Lower Coil Height (in.)	24	24	27	27	33	33	33	36	36	45	45	45	45
Upper Coil Height (in.)	N/A	N/A	N/A	N/A	N/A	N/A	N/A	N/A	N/A	N/A	N/A	N/A	N/A
Length (in.)	20	34	40	52	52	59	38	65	41	65	37	74	49
Total Face Area (sq ft)	3.3	5.7	7.5	9.8	11.9	13.5	8.7	16.3	10.3	20.3	14.7	23.1	15.3
<b>Medium Face Area</b>													
Nominal Capacity (cfm) at 700 fpm	1,458	2,479	3,500	4,550	6,825	8,604	5,542	9,479	5,979	12,323	8,910	14,029	9,290
Lower Coil Height (in.)	15	15	18	18	27	30	30	30	30	39	39	39	39
Upper Coil Height (in.)	N/A	N/A	N/A	N/A	N/A	N/A	N/A	N/A	N/A	N/A	N/A	N/A	N/A
Length (in.)	20	34	40	52	52	59	38	65	41	65	47	74	49
Total Face Area (sq ft)	2.1	3.5	5.0	6.5	9.8	12.3	7.9	13.5	8.5	17.6	12.7	20.0	13.3
<b>Small Face Area</b>													
Nominal Capacity (cfm) at 700 fpm	—	2,479	2,917	3,792	3,792	4,302	2,771	5,688	3,588	6,635	4,798	7,554	5,002
Height (in.)	—	15	15	15	15	15	15	18	18	21	21	21	21
Length (in.)	—	34	40	52	52	59	38	65	41	65	47	74	49
Total Face Area (sq ft)	—	3.5	4.2	5.4	5.4	6.1	4.0	8.1	5.1	9.5	6.9	10.8	7.1
<b>Bypass Face Area (Internal)</b>													
Nominal Capacity (cfm) at 700 fpm	1,458	2,479	2,917	3,792	6,067	6,883	4,433	8,531	5,381	10,427	7,540	11,871	7,860
Height (in.)	15	15	15	15	24	24	24	27	27	33	33	33	33
Length (in.)	20	34	40	52	52	59	38	65	41	65	47	74	49
Total Face Area (sq ft)	2.1	3.5	4.2	5.4	8.7	9.8	6.3	12.2	7.7	14.9	10.8	17.0	11.2

### COIL DATA (cont)

39M UNIT SIZE	30W	30T	35T	36W	37T	40W	50W	61W	72W	85W	96W	110W
<b>1/2-in. CHILLED WATER/DIRECT EXPANSION</b>												
<b>Large Face Area</b>												
Nominal Capacity (cfm) at 500 fpm	15,174	14,852	17,488	18,333	18,950	20,000	25,278	30,694	36,224	42,656	48,125	55,000
Lower Coil Height (in.)	47.5	37.5	37.5	55	47.5	30	35	42.5	50	50	55	55
Upper Coil Height (in.)	N/A	35.0	37.5	N/A	45	30	35	42.5	47.5	47.5	55	55
Length (in.)	92	59	67	96	59	96	104	104	107	126	126	144
Total Face Area (sq ft)	30.3	29.7	34.9	36.7	37.9	40.0	50.6	61.4	72.4	85.3	96.3	110.0
<b>Medium Face Area</b>												
Nominal Capacity (cfm) at 500 fpm	12,778	11,267	13,958	15,000	15,365	18,333	19,861	25,278	29,722	35,000	39,375	45,000
Lower Coil Height (in.)	40	55	30	45	37.5	55	55	35	40	40	45	45
Upper Coil Height (in.)	N/A	N/A	30	N/A	37.5	N/A	N/A	35	40	40	45	45
Length (in.)	92	59	67	96	59	96	104	104	107	126	126	144
Total Face Area (sq ft)	25.6	22.5	27.9	30.0	30.7	36.7	39.7	50.6	59.4	70.0	78.8	90.0
<b>Bypass Face Area (Internal Chilled Water Only)</b>												
Nominal Capacity (cfm) at 500 fpm	11,181	9,731	11,632	12,500	12,292	15,000	16,250	19,861	23,220	27,344	30,625	35,000
Lower Coil Height (in.)	35	47.5	50	37.5	30	45	45	55	32.5	32.5	35	35
Upper Coil Height (in.)	N/A	N/A	N/A	N/A	30	N/A	N/A	N/A	30	30	35	35
Length (in.)	92	59	67	96	59	96	104	104	107	126	126	144
Total Face Area (sq ft)	22.4	19.5	23.3	25.0	24.6	30.0	32.5	39.7	46.4	54.7	61.3	70.0
<b>1/2-in. HOT WATER HEATING</b>												
<b>Large Face Area</b>												
Nominal Capacity (cfm) at 700 fpm	21,243	20,793	24,427	25,667	26,530	28,000	35,389	42,972	50,714	59,719	67,375	77,000
Lower Coil Height (in.)	47.5	37.5	37.5	55	47.5	30	35	42.5	50	50	55	55
Upper Coil Height (in.)	N/A	35	37.5	N/A	45	30	35	42.5	47.5	47.5	55	55
Length (in.)	92	59	67	96	59	96	104	104	107	126	126	144
Total Face Area (sq ft)	30.3	29.7	27.9	36.7	37.9	40.0	50.6	61.4	72.4	85.3	96.3	110.0
<b>Medium Face Area</b>												
Nominal Capacity (cfm) at 700 fpm	17,889	15,774	19,542	21,000	21,510	25,667	27,806	35,389	41,611	49,000	55,125	63,000
Lower Coil Height (in.)	40	55	30	45	37.5	55	55	35	40	40	45	45
Upper Coil Height (in.)	N/A	N/A	30	N/A	37.5	N/A	N/A	35	40	40	45	45
Length (in.)	92	59	67	96	59	96	104	104	107	126	126	144
Total Face Area (sq ft)	25.6	22.5	37.9	30.0	30.7	36.7	39.7	50.6	59.4	70.0	78.8	90.0
<b>Small Face Area</b>												
Nominal Capacity (cfm) at 700 fpm	10,063	9,321	13,842	14,000	13,623	14,000	17,694	21,486	—	—	—	—
Height (in.)	22.5	32.5	42.5	30	47.5	30	35	42.5	—	—	—	—
Length (in.)	92	59	67	96	59	96	104	104	—	—	—	—
Total Face Area (sq ft)	14.4	13.3	19.8	20.0	19.5	20.0	25.3	30.7	—	—	—	—
<b>Bypass Face Area (Internal)</b>												
Nominal Capacity (cfm) at 700 fpm	15,653	13,623	16,285	17,500	17,208	21,000	22,750	27,806	32,509	38,281	42,875	49,000
Lower Coil Height (in.)	35	47.5	50	37.5	30	45	45	55	32.5	32.5	35	35
Upper Coil Height (in.)	N/A	N/A	N/A	N/A	30	N/A	N/A	N/A	30	30	35	35
Length (in.)	92	59	67	96	59	96	104	104	107	126	126	144
Total Face Area (sq ft)	22.4	19.5	23.3	25.0	24.6	30.0	32.5	39.7	46.4	54.7	61.3	70.0

# Physical data (cont)



## COIL DATA (cont)

39M UNIT SIZE	03W	06W	08W	10W	12W	14W	16T	17W	18T	21W	22T	25W	25T
<b>5/8-in. CHILLED WATER</b>													
<b>Large Face Area</b>													
Nominal Capacity (cfm) at 500 fpm	1,667	2,833	3,750	4,875	5,958	6,760	7,521	8,125	8,542	10,156	10,771	11,563	12,250
Lower Coil Height (in.)	24	24	27	27	33	33	30	36	30	45	33	45	36
Upper Coil Height (in.)	N/A	N/A	N/A	N/A	N/A	N/A	27	N/A	30	N/A	33	N/A	36
Length (in.)	20	34	40	52	52	59	38	65	41	65	47	74	49
Total Face Area (sq ft)	3.3	5.7	7.5	9.8	11.9	13.5	15.0	16.3	17.5	20.3	21.5	23.1	29.5
<b>Medium Face Area</b>													
Nominal Capacity (cfm) at 500 fpm	1,042	1,771	2,500	3,250	4,875	6,146	6,333	6,771	7,260	8,802	8,913	10,021	10,208
Lower Coil Height (in.)	15	15	18	18	27	30	48	30	51	39	54	39	30
Upper Coil Height (in.)	N/A	N/A	N/A	N/A	N/A	N/A	N/A	N/A	N/A	N/A	N/A	N/A	30
Length (in.)	20	34	40	52	52	59	38	65	41	65	47	74	49
Total Face Area (sq ft)	2.1	3.5	5.0	6.5	9.8	12.3	12.7	13.5	14.5	17.6	17.6	20.0	20.4
<b>Bypass Face Area (Internal Chilled Water Only)</b>													
Nominal Capacity (cfm) at 500 fpm	1,042	1,771	2,083	2,708	4,333	4,917	5,146	6,094	5,552	7,448	6,854	8,479	8,167
Lower Coil Height (in.)	15	15	15	15	24	24	39	27	39	33	42	33	48
Upper Coil Height (in.)	N/A	N/A	N/A	N/A	N/A	N/A	N/A	N/A	N/A	N/A	N/A	N/A	N/A
Length (in.)	20	34	40	52	52	59	38	65	41	65	47	74	49
Total Face Area (sq ft)	2.1	3.5	4.2	5.4	8.7	9.8	10.3	12.2	11.1	14.9	13.7	17.0	16.3
<b>5/8-in. HOT WATER HEATING</b>													
<b>Large Face Area</b>													
Nominal Capacity (cfm) at 700 fpm	2,333	3,967	5,250	6,825	8,342	9,465	10,529	11,375	11,958	14,219	15,079	16,188	17,150
Lower Coil Height (in.)	24	24	27	27	33	33	30	36	30	45	33	45	36
Upper Coil Height (in.)	N/A	N/A	N/A	N/A	N/A	N/A	27	N/A	30	N/A	33	N/A	36
Length (in.)	20	34	40	52	52	59	38	65	41	65	47	74	49
Total Face Area (sq ft)	3.3	5.7	7.5	9.8	11.9	13.5	15.0	16.3	17.1	20.3	21.5	23.1	24.5
<b>Medium Face Area</b>													
Nominal Capacity (cfm) at 700 fpm	1,458	2,479	3,500	4,550	6,825	8,604	8,867	9,479	10,165	12,323	12,338	14,029	14,292
Lower Coil Height (in.)	15	15	18	18	27	30	48	30	51	39	54	39	30
Upper Coil Height (in.)	N/A	N/A	N/A	N/A	N/A	N/A	N/A	N/A	N/A	N/A	N/A	N/A	30
Length (in.)	20	34	40	52	52	59	38	65	41	65	47	74	49
Total Face Area (sq ft)	2.1	3.5	5.0	6.5	9.8	12.3	12.7	13.5	14.5	17.6	17.6	20.0	20.4
<b>Small Face Area</b>													
Nominal Capacity (cfm) at 700 fpm	—	2,479	2,917	3,792	3,792	4,302	5,542	5,688	6,577	6,635	8,225	7,554	9,290
Height (in.)	—	15	15	15	15	15	30	18	33	21	36	21	39
Length (in.)	—	34	40	52	52	59	38	65	41	65	47	74	49
Total Face Area (sq ft)	—	3.5	4.2	5.4	5.4	6.1	7.9	8.1	9.4	9.5	11.8	10.8	13.3
<b>Bypass Face Area (Internal)</b>													
Nominal Capacity (cfm) at 700 fpm	1,458	2,479	2,917	3,792	6,067	6,883	7,204	8,531	7,773	10,427	9,596	11,871	11,433
Lower Coil Height (in.)	15	15	15	15	24	24	39	27	39	33	42	33	48
Upper Coil Height (in.)	N/A	N/A	N/A	N/A	N/A	N/A	N/A	N/A	N/A	N/A	N/A	N/A	N/A
Length (in.)	20	34	40	52	52	59	38	65	41	65	47	74	49
Total Face Area (sq ft)	2.1	3.5	4.2	5.4	8.7	9.8	10.3	12.2	11.1	14.9	13.7	17.0	16.3
<b>1-in. STEAM HEATING</b>													
<b>Large Face Area</b>													
Nominal Capacity (cfm) at 700 fpm	2,333	3,967	5,250	6,825	8,342	9,465	6,096	11,375	7,175	14,219	10,281	16,188	10,719
Lower Coil Height (in.)	24	24	27	27	33	33	33	36	36	45	45	45	45
Upper Coil Height (in.)	N/A	N/A	N/A	N/A	N/A	N/A	N/A	N/A	N/A	N/A	N/A	N/A	N/A
Length (in.)	20	34	40	52	52	59	38	65	41	65	47	74	49
Total Face Area (sq ft)	3.3	5.7	7.5	9.8	11.9	13.5	8.7	16.3	10.3	20.3	14.7	23.1	15.3
<b>Medium Face Area</b>													
Nominal Capacity (cfm) at 700 fpm	1,458	2,479	3,500	4,550	6,825	8,604	5,542	9,479	5,979	12,323	8,910	14,029	9,290
Lower Coil Height (in.)	15	15	18	18	27	30	30	30	30	39	39	39	39
Upper Coil Height (in.)	N/A	N/A	N/A	N/A	N/A	N/A	N/A	N/A	N/A	N/A	N/A	N/A	N/A
Length (in.)	20	34	40	52	52	59	38	65	41	65	47	74	49
Total Face Area (sq ft)	2.1	3.5	5.0	6.5	9.8	12.3	8.7	13.5	8.5	17.6	12.7	20.0	9,290
<b>Small Face Area</b>													
Nominal Capacity (cfm) at 700 fpm	—	2,479	2,917	3,792	3,792	4,302	2,771	5,688	3,558	6,635	4,798	7,554	5,002
Height (in.)	—	15	15	15	15	15	15	18	18	21	21	21	21
Length (in.)	—	34	40	52	52	59	38	65	41	65	47	74	49
Total Face Area (sq ft)	—	3.5	4.2	5.4	5.4	6.1	4.0	8.1	5.1	9.5	6.9	10.8	7.1
<b>Bypass Face Area (Internal)</b>													
Nominal Capacity (cfm) at 700 fpm	1,458	2,479	2,917	3,792	6,067	6,883	4,433	8,531	5,381	10,427	7,540	11,871	7,860
Lower Coil Height (in.)	15	15	15	15	24	24	24	27	27	33	33	33	33
Upper Coil Height (in.)	N/A	N/A	N/A	N/A	N/A	N/A	N/A	N/A	N/A	N/A	N/A	N/A	N/A
Length (in.)	20	34	40	52	52	59	38	65	41	65	47	74	49
Total Face Area (sq ft)	2.1	3.5	4.2	5.4	8.7	9.8	6.3	12.2	7.7	14.9	10.8	17.0	11.2
<b>5/8-in. HOT WATER INTEGRAL FACE AND BYPASS</b>													
Nominal Capacity (cfm)	—	3,000	4,000	5,000	6,000	7,000	800	8,500	900	10,500	11,000	12,500	12,500
Coil Height (in.)	—	22.9	30.6	30.6	30.6	30.6	30.6	24	24	33	33	33	33
Length (in.)	—	24	30	39	39	45	45	59.4	59.4	59.4	59.4	59.4	59.4
Total Face Area (sq ft)	—	3.3	5.7	7.4	7.4	8.5	7.6	9.2	8.1	12.6	13.00	12.6	14.7
<b>5/8-in. STEAM INTEGRAL FACE AND BYPASS</b>													
Nominal Capacity (cfm)	—	3,000	4,000	5,000	6,000	7,000	8000	8,500	9000	10,500	11,000	12,500	12,500
Coil Height (in.)	—	22.88	30.56	30.56	30.56	30.56	30.56	24	24	33	33	33	33
Length (in.)	—	24	30	39	39	45	45	59.38	59.38	59.38	59.38	59.38	59.38
Total Face Area (sq ft)	—	3.3	5.7	7.4	7.4	8.5	7.6	9.2	8.1	12.6	13.5	12.6	14.7

### COIL DATA (cont)

39M UNIT SIZE	30W	30T	35T	36W	37T	40W	50W	61W	72W	85W	96W	110W
<b>5/8-in. CHILLED WATER</b>												
<b>Large Face Area</b>												
Nominal Capacity (cfm) at 500 fpm	14,375	14,705	17,448	18,000	18,438	20,000	24,917	30,333	35,667	42,000	47,250	54,000
Lower Coil Height (in.)	45	36	39	54	45	30	36	42	48	48	54	54
Upper Coil Height (in.)	N/A	36	36	N/A	45	30	33	42	48	48	54	54
Length (in.)	92	59	67	96	59	96	104	104	107	126	126	144
Total Face Area (sq ft)	28.8	29.5	34.9	36.0	36.9	40.0	49.8	60.7	71.3	84.0	94.5	108.0
<b>Medium Face Area</b>												
Nominal Capacity (cfm) at 500 fpm	12,458	12,906	15,354	15,000	15,979	18,000	19,500	24,917	28,979	34,125	38,063	43,500
Lower Coil Height (in.)	39	33	33	45	39	54	54	36	39	39	45	45
Upper Coil Height (in.)	N/A	30	33	N/A	39	N/A	N/A	33	39	39	42	42
Length (in.)	92	59	67	96	59	96	104	104	107	126	126	144
Total Face Area (sq ft)	24.9	25.8	30.7	30.0	32.0	36.0	39.0	49.8	58.0	68.3	76.1	87.0
<b>Bypass Face Area (Internal Chilled Water Only)</b>												
Nominal Capacity (cfm) at 500 fpm	10,542	9,833	11,865	12,000	12,292	15,000	16,250	19,500	23,406	27,563	31,500	36,000
Lower Coil Height (in.)	33	48	51	36	30	45	45	54	33	33	36	36
Upper Coil Height (in.)	N/A	N/A	N/A	N/A	30	N/A	N/A	N/A	30	30	36	36
Length (in.)	92	59	67	96	59	96	104	104	107	126	126	144
Total Face Area (sq ft)	21.1	19.7	23.7	24.0	24.6	30.0	32.5	39.0	46.8	55.1	63.0	72.0
<b>5/8-in. HOT WATER HEATING</b>												
<b>Large Face Area</b>												
Nominal Capacity (cfm) at 700 fpm	20,125	20,650	24,427	25,200	25,813	28,000	34,883	42,467	49,933	58,800	66,150	75,600
Lower Coil Height (in.)	45	36	39	54	45	30	36	42	48	48	54	54
Upper Coil Height (in.)	N/A	36	36	N/A	45	30	33	42	48	48	54	54
Length (in.)	92	59	59	96	67	96	104	104	107	126	126	144
Total Face Area (sq ft)	28.8	29.5	29.5	36.0	34.9	40.0	49.8	60.7	71.3	84.0	94.5	108.0
<b>Medium Face Area</b>												
Nominal Capacity (cfm) at 700 fpm	17,442	18,069	21,496	21,000	22,371	25,200	27,300	34,883	40,571	47,775	53,288	60,900
Lower Coil Height (in.)	39	33	33	45	39	54	54	36	39	39	45	45
Upper Coil Height (in.)	N/A	30	33	N/A	38	N/A	N/A	33	39	39	42	42
Length (in.)	92	59	67	96	59	96	104	104	107	126	126	144
Total Face Area (sq ft)	24.9	25.8	30.7	30.0	32	36.0	39.0	49.8	58.0	68.3	76.1	87.0
<b>Small Face Area</b>												
Nominal Capacity (cfm) at 700 fpm	9,392	11,185	12,702	14,000	14,627	14,000	16,683	21,233	—	—	—	—
Height (in.)	21	39	39	30	51	30	33	42	—	—	—	—
Length (in.)	92	59	67	96	59	96	104	104	—	—	—	—
Total Face Area (sq ft)	13.4	19.7	18.1	20.0	20.9	20.0	23.8	30.3	—	—	—	—
<b>Bypass Face Area (Internal)</b>												
Nominal Capacity (cfm) at 700 fpm	14,758	13,767	16,610	16,800	17,208	21,000	22,750	27,300	32,769	38,588	44,100	50,400
Lower Coil Height (in.)	33	48	51	36	30	45	45	54	33	33	36	36
Upper Coil Height (in.)	N/A	N/A	N/A	N/A	30	N/A	N/A	N/A	30	30	36	36
Length (in.)	92	59	67	96	59	96	104	104	107	126	126	144
Total Face Area (sq ft)	21.1	16.0	23.7	24.0	24.6	30.0	32.5	39.0	46.8	55.1	63.0	72.0
<b>1-in. STEAM HEATING</b>												
<b>Large Face Area</b>												
Nominal Capacity (cfm) at 700 fpm	20,125	12,906	17,588	25,200	15,488	28,000	34,883	42,467	49,933	58,800	66,150	75,600
Lower Coil Height (in.)	45	45	54	54	54	30	36	42	48	48	54	54
Upper Coil Height (in.)	N/A	N/A	N/A	N/A	N/A	30	33	42	48	48	54	54
Length (in.)	92	59	67	96	59	96	104	104	107	126	126	144
Total Face Area (sq ft)	28.8	18.4	25.1	36.0	22.1	40.0	49.8	60.7	71.3	84.0	94.5	108.0
<b>Medium Face Area</b>												
Nominal Capacity (cfm) at 700 fpm	17,442	11,185	14,656	21,000	12,906	25,200	27,300	34,883	40,571	47,775	53,288	60,900
Lower Coil Height (in.)	39	39	45	45	45	54	54	36	39	39	45	45
Upper Coil Height (in.)	N/A	N/A	N/A	N/A	N/A	N/A	N/A	33	39	39	42	42
Length (in.)	92	59	67	96	59	96	104	104	107	126	126	144
Total Face Area (sq ft)	24.9	19.7	20.9	30.0	18.4	36.0	39.0	49.8	58.0	68.3	76.1	87.0
<b>Small Face Area</b>												
Nominal Capacity (cfm) at 700 fpm	9,392	6,023	9,771	14,000	8,604	14,000	16,683	21,233	—	—	—	—
Height (in.)	21	21	30	30	30	30	33	42	—	—	—	—
Length (in.)	92	59	67	96	59	96	104	104	—	—	—	—
Total Face Area (sq ft)	13.4	8.6	14.0	20.0	12.3	20.0	23.8	30.3	—	—	—	—
<b>Bypass Face Area (Internal)</b>												
Nominal Capacity (cfm) at 700 fpm	14,758	9,465	11,725	16,800	10,325	21,000	22,750	27,300	32,769	38,588	44,100	50,400
Lower Coil Height (in.)	33	33	36	36	36	45	45	54	33	33	36	36
Upper Coil Height (in.)	N/A	N/A	N/A	N/A	N/A	N/A	N/A	N/A	30	30	36	36
Length (in.)	92	59	67	96	59	96	104	104	107	126	126	144
Total Face Area (sq ft)	21.1	13.5	16.8	24.0	14.8	30.0	32.5	39.0	46.8	55.1	63.0	72.0
<b>5/8-in. HOT WATER INTEGRAL FACE AND BYPASS</b>												
Nominal Capacity (cfm)	15,000	15,000	17,500	18,000	18,500	20,000	25,000	30,500	36,000	42,500	48,000	55,000
Coil Height (in.)	33	33	45	45	45	51	60	75	87	87	96	96
Length (in.)	81.4	81.4	81.4	81.4	81.4	81.4	92.4	92.4	92.4	114.4	114.4	136.4
Total Face Area (sq ft)	17.6	19.6	25.6	24.1	25.4	27.3	36.7	45.8	53.2	66.5	73.3	88.0
<b>5/8-in. STEAM INTEGRAL FACE AND BYPASS</b>												
Nominal Capacity (cfm)	15,000	15,000	17,500	18,000	18,500	20,000	25,000	30,500	36,000	42,500	48,000	55,000
Coil Height (in.)	33	33	45	45	45	51	60	75	87	87	96	96
Length (in.)	81.4	81.4	81.4	81.4	81.4	81.4	92.4	92.4	92.4	114.4	114.4	136.4
Total Face Area (sq ft)	17.6	19.6	25.6	25.6	25.4	27.3	36.7	45.8	53.2	66.5	73.3	88.0

# Physical data (cont)



## 1/2-in. WATER COIL CONNECTION SIZES

FACE AREA	ROWS	CIRCUIT TYPE	39M UNIT SIZE																									
			03W	06W	08W	10W	12W	14W	16T	17W	18T	21W	22T	25W	25T	30W	30T	35T	36W	37T	40W	50W	61W	72W	85W	96W	110W	
			Nozzle Size (in. MPT)																									
LARGE	1, 2	HALF/FULL	1.5	1.5	1.5	1.5	1.5	1.5	1.5	2.5	2.5	2.5	2.5	2.5	2.5	2.5	2.5	2.5	2.5	2.5	2.5	(2)1.5	(2)1.5	(2)2.5	(2)2.5	(2)2.5	(2)2.5	(2)2.5
	4	HALF/FULL	1.5	1.5	1.5	1.5	1.5	1.5	1.5	2.5	2.5	2.5	2.5	2.5	2.5	2.5	2.5	2.5	2.5	2.5	2.5	2.5	(2)1.5	(2)1.5	(2)2.5	(2)2.5	(2)2.5	(2)2.5
		DOUBLE	2.5	2.5	2.5	2.5	2.5	2.5	2.5	2.5	2.5	2.5	2.5	2.5	2.5	2.5	2.5	2.5	2.5	2.5	2.5	2.5	(2)2.5	(2)2.5	(2)2.5	(2)2.5	(2)2.5	(2)2.5
	6, 8, 10	HALF	1.5	1.5	1.5	1.5	2.5	2.5	2.5	2.5	2.5	2.5	2.5	2.5	2.5	2.5	2.5	2.5	2.5	2.5	2.5	2.5	(2)1.5	(2)2.5	(2)2.5	(2)2.5	(2)2.5	(2)2.5
		DOUBLE	1.5	1.5	1.5	1.5	2.5	2.5	2.5	2.5	2.5	2.5	2.5	2.5	2.5	2.5	2.5	2.5	3	3	3	3	(2)1.5	(2)2.5	(2)2.5	(2)3	(2)3	(2)3
	MEDIUM	1, 2	HALF/FULL	1.5	1.5	1.5	1.5	1.5	1.5	1.5	1.5	1.5	1.5	2.5	2.5	2.5	2.5	2.5	2.5	2.5	2.5	2.5	2.5	2.5	2.5	2.5	2.5	2.5
4		HALF/FULL	1.5	1.5	1.5	1.5	1.5	1.5	1.5	1.5	1.5	1.5	2.5	2.5	2.5	2.5	2.5	2.5	2.5	2.5	2.5	2.5	2.5	2.5	2.5	2.5	2.5	
		DOUBLE	2.5	2.5	2.5	2.5	2.5	2.5	2.5	2.5	2.5	2.5	2.5	2.5	2.5	2.5	2.5	2.5	2.5	2.5	2.5	2.5	2.5	2.5	2.5	2.5	2.5	
6, 8, 10		HALF	1.5	1.5	1.5	1.5	1.5	1.5	1.5	1.5	1.5	1.5	2.5	2.5	2.5	2.5	2.5	2.5	2.5	2.5	2.5	2.5	2.5	2.5	2.5	2.5	2.5	
		DOUBLE	1.5	1.5	1.5	1.5	1.5	1.5	1.5	1.5	1.5	1.5	2.5	2.5	2.5	2.5	2.5	2.5	2.5	2.5	2.5	2.5	2.5	2.5	2.5	2.5	2.5	
BYPASS		1, 2	HALF/FULL	1.5	1.5	1.5	1.5	1.5	1.5	1.5	1.5	1.5	1.5	1.5	3	1.5	3	1.5	2.5	2.5	2.5	2.5	2.5	2.5	2.5	2.5	2.5	2.5
	4	HALF/FULL	1.5	1.5	1.5	1.5	1.5	1.5	2.5	1.5	2.5	1.5	2.5	1.5	2.5	1.5	1.5	2.5	2.5	2.5	2.5	2.5	2.5	2.5	2.5	2.5	2.5	
		DOUBLE	1.5	1.5	1.5	1.5	1.5	1.5	1.5	1.5	1.5	1.5	2.5	2.5	2.5	2.5	2.5	2.5	2.5	2.5	2.5	2.5	2.5	2.5	2.5	2.5	2.5	
	6, 8, 10	HALF/FULL	1.5	1.5	1.5	1.5	1.5	1.5	1.5	2.5	1.5	1.5	2.5	2.5	2.5	2.5	2.5	2.5	2.5	2.5	2.5	2.5	2.5	2.5	2.5	2.5	2.5	
		DOUBLE	2.5	2.5	2.5	2.5	2.5	2.5	3	2.5	3	2.5	3	2.5	3	2.5	3	3	3	3	3	3	3	3	3	3	3	
	SMALL	1, 2	HALF/FULL	—	1.5	1.5	1.5	1.5	1.5	1.5	1.5	1.5	1.5	1.5	1.5	1.5	1.5	1.5	1.5	1.5	1.5	1.5	1.5	1.5	1.5	1.5	1.5	
4		HALF/FULL	—	1.5	1.5	1.5	1.5	1.5	1.5	1.5	1.5	1.5	1.5	1.5	1.5	1.5	1.5	1.5	1.5	1.5	1.5	1.5	1.5	1.5	1.5	1.5		
		DOUBLE	—	2.5	2.5	2.5	2.5	2.5	2.5	2.5	2.5	2.5	2.5	2.5	2.5	2.5	2.5	2.5	2.5	2.5	2.5	2.5	2.5	2.5	2.5	2.5	2.5	

NOTES:

1. Large face area sizes 40, 50 and 61 and medium face area size 61 units have 2 sets of water coil connections.
2. All 72-110 size units have 2 sets of water coil connections.

## 5/8-in. WATER COIL CONNECTION SIZES

FACE AREA	ROWS	CIRCUIT TYPE	39M UNIT SIZE																								
			03W	06W	08W	10W	12W	14W	16T	17W	18T	21W	22T	25W	25T	30W	30T	35T	36W	37T	40W	50W	61W	72W	85W	96W	110W
			Nozzle Size (in. MPT)																								
LARGE	1	HALF	1.5	1.5	1.5	1.5	1.5	1.5	1.5	1.5	2	2	2	2	2	2	2	2	2	2	2	(2)1.5	(2)1.5	(2)2	(2)2	(2)2	(2)2
	2, 4	HALF	1.5	1.5	1.5	1.5	1.5	1.5	1.5	1.5	1.5	2	2	2	2	2	2	2	2	2	2	2	(2)1.5	(2)1.5	(2)2	(2)2	(2)2
		FULL	2	2	2	2	2.5	2.5	2.5	2.5	2.5	2.5	2.5	2.5	2.5	2.5	2.5	2.5	2.5	2.5	2.5	2.5	(2)2	(2)2.5	(2)2.5	(2)2.5	(2)2.5
	6, 8	FULL	2	2	2	2	2.5	2.5	2.5	2.5	2.5	3	3	3	3	3	3	3	3	3	3	3	(2)2	(2)2.5	(2)2.5	(2)3	(2)3
		DOUBLE	2.5	2.5	2.5	2.5	2.5	2.5	2.5	2.5	2.5	2.5	2.5	2.5	2.5	2.5	2.5	2.5	2.5	2.5	2.5	2.5	2.5	2.5	2.5	2.5	2.5
	MEDIUM	1	HALF	1.5	1.5	1.5	1.5	1.5	1.5	1.5	1.5	2	2	2	2	2	2	2	2	2	2	2	(2)1.5	(2)2	(2)2	(2)2	(2)2
2, 4		HALF	1.5	1.5	1.5	1.5	1.5	1.5	1.5	1.5	2	2	2	2	2	2	2	2	2	2	2	2	(2)1.5	(2)2	(2)2	(2)2	(2)2
		FULL	1.5	1.5	2	2	2	2.5	2.5	2.5	2.5	2.5	2.5	2.5	2.5	2.5	2.5	2.5	2.5	2.5	2.5	2.5	2.5	2.5	2.5	2.5	2.5
6, 8		FULL	1.5	1.5	2	2	2	2.5	2.5	2.5	2.5	2.5	2.5	2.5	2.5	2.5	2.5	2.5	2.5	2.5	2.5	2.5	2.5	2.5	2.5	2.5	2.5
		DOUBLE	2.5	2.5	2.5	2.5	2.5	2.5	2.5	2.5	2.5	2.5	2.5	2.5	2.5	2.5	2.5	2.5	2.5	2.5	2.5	2.5	2.5	2.5	2.5	2.5	2.5
BYPASS		1	HALF	1.5	1.5	1.5	1.5	1.5	1.5	1.5	1.5	1.5	1.5	1.5	1.5	1.5	1.5	1.5	1.5	1.5	1.5	1.5	1.5	1.5	1.5	1.5	1.5
	2, 4	HALF	1.5	1.5	1.5	1.5	1.5	1.5	1.5	1.5	1.5	1.5	1.5	1.5	1.5	1.5	1.5	1.5	1.5	1.5	1.5	1.5	1.5	1.5	1.5	1.5	
		FULL	1.5	1.5	1.5	1.5	2	2	2	2	2	2	2.5	2.5	2.5	2.5	2.5	2.5	2.5	2.5	2.5	2.5	2.5	2.5	2.5	2.5	2.5
	6, 8	FULL	1.5	1.5	1.5	1.5	2	2	2	2	2	2	2.5	2.5	2.5	2.5	2.5	2.5	2.5	2.5	2.5	2.5	2.5	2.5	2.5	2.5	2.5
		DOUBLE	2.5	2.5	2.5	2.5	2.5	2.5	2.5	2.5	2.5	2.5	2.5	2.5	2.5	2.5	2.5	2.5	2.5	2.5	2.5	2.5	2.5	2.5	2.5	2.5	2.5
	SMALL	1	HALF	—	1.5	1.5	1.5	1.5	1.5	1.5	1.5	1.5	1.5	1.5	1.5	1.5	1.5	1.5	1.5	1.5	1.5	1.5	1.5	1.5	1.5	1.5	1.5
2		HALF	—	1.5	1.5	1.5	1.5	1.5	1.5	1.5	1.5	1.5	1.5	1.5	1.5	1.5	1.5	1.5	1.5	1.5	1.5	1.5	1.5	1.5	1.5	1.5	
		FULL	—	1.5	1.5	1.5	1.5	1.5	1.5	1.5	1.5	2	2	2	2	2	2	2	2	2	2	2	2	2	2	2	2

NOTES:

1. Large face area sizes 40, 50 and 61 and medium face area size 61 units have 2 sets of water coil connections.
2. All 72-110 size units have 2 sets of water coil connections.



### 1-in. STEAM COIL CONNECTION SIZES

FACE AREA	ROWS	CONNECTION	39M UNIT SIZE																								
			03W	06W	08W	10W	12W	14W	16T	17W	18T	21W	22T	25W	25T	30W	30T	35T	36W	37T	40W	50W	61W	72W	85W	96W	110W
			Nozzle Size (in. MPT)																								
ALL*	ALL	INLET	2.5	2.5	2.5	2.5	2.5	2.5	2.5	2.5	2.5	2.5	2.5	2.5	2.5	2.5	2.5	2.5	2.5	2.5	2.5	2.5	2.5	(2)2.5	(2)2.5	(2)2.5	(2)2.5
		OUTLET	2.5	2.5	2.5	2.5	2.5	2.5	2.5	2.5	2.5	2.5	2.5	2.5	2.5	2.5	2.5	2.5	2.5	2.5	2.5	2.5	2.5	2.5	(2)2.5	(2)2.5	(2)2.5

\*Large face area sizes 40, 50 and 61 and medium face area size 61 units have 2 sets of steam coil connections.

### 5/8-in. STEAM COIL CONNECTION SIZES

FACE AREA	ROWS	CONNECTION	39M UNIT SIZE																								
			03W	06W	08W	10W	12W	14W	16T	17W	18T	21W	22T	25W	25T	30W	30T	35T	36W	37W	40W	50W	61W	72W	85W	96W	110W
			Nozzle Size (in. MPT)																								
LARGE	1	INLET	2	2	2	2	2	2	(2)2	2	(2)2	2.5	(2)2	2.5	(2)2	—	—	—	—	—	—	—	—	—	—	—	—
		OUTLET	2	2	2	2	2	2	2	2	2	2	2	2	2	—	—	—	—	—	—	—	—	—	—	—	—
		INLET	2	2	2	2	2	2	2.5	2	2.5	2	2.5	2	(2)2	—	—	—	—	—	—	—	—	—	—	—	—
		OUTLET	2	2	2	2	2	2	2	2	2	2	2	2	2	—	—	—	—	—	—	—	—	—	—	—	—
		INLET	2	2	2	2	2	2	2	2	2	2	2	2	2	—	—	—	—	—	—	—	—	—	—	—	—
		OUTLET	2	2	2	2	2	2	2	2	2	2	2	2	2	—	—	—	—	—	—	—	—	—	—	—	—
MEDIUM	2	INLET	2.5	2.5	2.5	2.5	2.5	2.5	(2)2.5	2.5	(2)2.5	3	(2)2.5	3	(2)2.5	—	—	—	—	—	—	—	—	—	—	—	—
		OUTLET	2.5	2.5	2.5	2.5	2.5	2.5	2.5	2.5	2.5	2.5	2.5	2.5	2.5	—	—	—	—	—	—	—	—	—	—	—	—
		INLET	2.5	2.5	2.5	2.5	2.5	2.5	3	2.5	3	2.5	3	2.5	(2)2.5	—	—	—	—	—	—	—	—	—	—	—	—
		OUTLET	2.5	2.5	2.5	2.5	2.5	2.5	2.5	2.5	2.5	2.5	2.5	2.5	2.5	—	—	—	—	—	—	—	—	—	—	—	—
		INLET	2.5	2.5	2.5	2.5	2.5	2.5	2.5	2.5	2.5	2.5	2.5	2.5	2.5	3	—	—	—	—	—	—	—	—	—	—	—
		OUTLET	2.5	2.5	2.5	2.5	2.5	2.5	2.5	2.5	2.5	2.5	2.5	2.5	2.5	2.5	—	—	—	—	—	—	—	—	—	—	—
SMALL	3	INLET	2.5	2.5	2.5	2.5	2.5	2.5	2.5	2.5	2.5	2.5	2.5	2.5	—	—	—	—	—	—	—	—	—	—	—	—	
		OUTLET	2.5	2.5	2.5	2.5	2.5	2.5	2.5	2.5	2.5	2.5	2.5	2.5	—	—	—	—	—	—	—	—	—	—	—	—	

### HOT WATER — INTEGRAL FACE AND BYPASS COIL CONNECTION SIZES

ROWS	CONNECTION	39M UNIT SIZE																									
		03W	06W	08W	10W	12W	14W	16T	17W	18T	21W	22T	25W	25T	30W	30T	35T	36W	37T	40W	50W	61W	72W	85W	96W	110W	
		Nozzle Size (in. MPT)																									
1	INLET	—	2.5	2.5	2.5	2.5	2.5	2	2	2	2	2	2	2	2	2	2	2	2	2	2	2	2	2	2	2	
	OUTLET	—	2.5	2.5	2.5	2.5	2.5	2	2	2	2	2	2	2	2	2	2	2	2	2	2	2	2	2	2	2	
2	INLET	—	2.5	2.5	2.5	2.5	2.5	2	2	2	2	2	2	2	2.5	2	2	2.5	2	2.5	2	2.5	2.5	2.5	3	3	3
	OUTLET	—	2.5	2.5	2.5	2.5	2.5	2	2	2	2	2	2	2	2.5	2	2.5	2.5	2	2.5	2.5	2.5	2.5	3	3	3	
3	INLET	—	2.5	2.5	2.5	2.5	2.5	2	2	2	2	2	2	2	2.5	2	2.5	2.5	2	2.5	2.5	2.5	2.5	3	3	3	
	OUTLET	—	2.5	2.5	2.5	2.5	2.5	2	2	2	2	2	2	2	2.5	2	2.5	2.5	2	2.5	2.5	2.5	2.5	3	3	3	

### STEAM — INTEGRAL FACE AND BYPASS COIL CONNECTION SIZES

ROWS	CONNECTION	39M UNIT SIZE																								
		03W	06W	08W	10W	12W	14W	16T	17W	18T	21W	22T	25W	25T	30W	30T	35T	36W	37T	40W	50W	61W	72W	85W	96W	110W
		Nozzle Size (in. MPT)																								
1	INLET	—	2.5	2.5	2.5	2.5	2.5	2.5	2.5	2.5	2.5	2.5	2.5	2.5	2.5	2.5	2.5	2.5	2.5	2.5	2.5	3	3	3	3	3
	OUTLET	—	2.5	2.5	2.5	2.5	2.5	2	2	2	2	2	2	2	2	2	2	2	2	2	2	2.5	2.5	2.5	2.5	2.5
2	INLET	—	2.5	2.5	2.5	2.5	2.5	2.5	3	2.5	3	2.5	3	2.5	3	2.5	3	3	2.5	3	3	3	3	4	4	4
	OUTLET	—	2.5	2.5	2.5	2.5	2.5	2	2.5	2	2.5	2	2.5	2	2.5	2	2.5	2.5	2	2.5	2.5	2.5	2.5	3	3	3
3	INLET	—	2.5	2.5	2.5	2.5	2.5	2.5	3	2.5	3	2.5	3	2.5	3	2.5	3	3	2.5	3	3	3	3	4	4	4
	OUTLET	—	2.5	2.5	2.5	2.5	2.5	2	2.5	2	2.5	2	2.5	2	2.5	2	2.5	2.5	2	2.5	2.5	2.5	2.5	3	3	3

# Physical data (cont)



## OPERATING CHARGE (Approximate) — DIRECT-EXPANSION COIL

ROWS	CONNECTION	39M UNIT SIZE																								
		03W	06W	08W	10W	12W	14W	16T	17W	18T	21W	22T	25W	25T	30W	30T	35T	36W	37T	40W	50W	61W	72W	85W	96W	110W
		Refrigerant R-410A (lb)																								
4	Large	1	3	4	4	5	6	7	7	8	9	10	11	11	13	13	15	16	16	18	22	27	32	37	42	48
	Medium	1	2	3	3	4	5	5	6	6	7	7	8	8	10	10	12	12	12	13	17	20	24	28	32	36
6	Large	2	4	6	7	9	10	12	12	13	15	16	18	18	22	22	26	26	27	29	37	45	53	62	70	80
	Medium	2	3	4	5	7	8	9	9	10	11	12	14	14	16	16	19	20	20	22	27	33	39	47	53	60
8	Large	3	6	8	10	12	15	17	18	19	22	23	26	26	31	31	36	37	38	42	52	63	75	88	100	114
	Medium	2	5	6	8	9	11	12	13	14	16	17	20	20	23	23	27	28	29	31	39	48	56	66	75	86

## COIL VOLUME (Gal. Water)

39M UNIT SIZE	03W	06W	08W	10W	12W	14W	16T	17W	18T	21W	22T	25W	25T	30W	30T	35T	36W	37T	40W	50W	61W	72W	85W	96W	110W	
<b>CHILLED WATER</b>																										
<b>Large Face Area</b>																										
4-Row	1.4	2.2	2.8	3.7	4.7	5.3	5.7	6.2	6.6	7.8	8.1	8.9	9.1	11.0	10.9	12.7	13.3	13.9	14.5	18.3	22.2	26.2	30.7	34.7	39.6	
6-Row	2.0	3.3	4.3	5.5	7.0	7.9	8.5	9.3	9.9	11.8	12.2	13.3	13.6	16.5	16.3	19.1	19.9	20.8	21.7	27.4	33.3	39.3	46.1	52.0	59.3	
8-Row	2.7	4.4	5.7	7.3	9.3	10.5	11.3	12.4	13.2	15.7	16.3	17.8	18.2	22.0	21.8	25.5	26.5	27.8	29.0	36.5	44.4	52.3	61.5	69.3	79.1	
10-Row	3.4	5.5	7.1	9.1	11.6	13.1	14.1	15.5	16.5	19.6	20.3	22.2	22.7	27.5	27.2	31.8	33.2	34.7	36.2	45.7	55.5	65.4	76.8	86.7	98.9	
<b>Medium Face Area</b>																										
4-Row	0.9	1.5	2.1	2.7	3.7	4.5	4.4	4.9	5.6	6.6	6.6	7.5	6.9	9.3	8.3	10.2	10.9	11.3	13.3	14.4	18.3	21.5	25.2	28.4	32.4	
6-Row	1.4	2.3	3.1	4.0	5.5	6.8	6.6	7.4	8.3	9.9	9.9	11.2	10.4	13.9	12.4	15.3	16.3	16.9	19.9	21.5	27.4	32.2	37.8	42.6	48.5	
8-Row	1.9	3.1	4.1	5.3	7.3	9.0	8.9	9.9	11.1	13.2	13.3	15.0	13.8	18.5	16.5	20.4	21.7	22.5	26.5	28.7	36.5	42.9	50.4	56.7	64.7	
10-Row	2.4	3.9	5.2	6.6	9.1	11.3	11.1	12.4	13.9	16.5	16.6	18.7	17.7	23.1	20.6	25.5	27.1	28.1	33.2	35.9	45.7	53.7	63.0	70.9	80.9	
<b>Small Face Area</b>																										
4-Row	—	1.3	1.5	2.0	2.3	2.6	3.0	3.3	3.4	3.7	3.9	4.2	4.1	5.2	4.9	7.2	7.2	7.1	7.2	9.1	11.1	—	—	—	—	
<b>Bypass Face Area</b>																										
4-Row	0.8	1.3	1.8	2.3	3.3	3.8	3.7	4.5	4.2	5.8	5.1	6.5	6.0	8.1	7.1	8.5	9.0	9.0	10.9	11.7	14.4	16.8	19.7	22.1	25.2	
6-Row	1.2	2.0	2.7	3.5	5.0	5.6	5.5	6.8	6.3	8.7	7.7	9.8	8.9	12.2	10.7	12.7	13.6	13.5	16.3	17.6	21.5	25.2	29.6	33.1	37.8	
8-Row	1.6	2.7	3.6	4.7	6.6	7.5	7.4	9.1	8.5	11.5	10.2	13.1	11.9	16.2	14.3	17.0	18.1	18.0	21.7	23.5	28.7	33.6	39.4	44.1	50.3	
10-Row	2.0	3.3	4.5	5.8	8.3	9.4	9.2	11.3	10.6	14.4	12.8	16.4	14.9	20.3	17.8	21.2	22.6	22.5	27.1	29.4	35.9	41.9	49.3	55.2	62.9	
<b>HOT WATER</b>																										
<b>Large Face Area</b>																										
1-Row	0.3	0.6	0.7	0.9	1.2	1.3	1.4	1.5	1.7	2.0	2.0	2.2	2.3	2.7	2.7	3.2	3.3	3.5	3.6	4.6	5.5	6.5	7.7	8.7	9.9	
2-Row	0.7	1.1	1.4	1.8	2.3	2.6	2.8	3.1	3.3	3.9	4.1	4.4	4.5	5.5	5.4	6.4	6.6	6.9	7.2	9.1	11.1	13.1	15.4	17.3	19.8	
<b>Medium Face Area</b>																										
1-Row	0.2	0.4	0.5	0.7	0.9	1.1	1.1	1.2	1.4	1.6	1.7	1.9	1.7	2.3	2.1	2.5	2.7	2.8	3.3	3.6	4.6	5.4	6.3	7.1	8.1	
2-Row	0.5	0.8	1.0	1.3	1.8	2.3	2.2	2.5	2.8	3.3	3.3	3.7	3.5	4.6	4.1	5.1	5.4	5.6	6.6	7.2	9.1	10.7	12.6	14.2	16.2	
<b>Small Face Area</b>																										
1-Row	—	0.3	0.4	0.5	0.6	0.7	0.7	0.8	0.9	0.9	1.0	1.1	1.0	1.3	1.2	1.8	1.8	1.8	1.8	2.3	2.8	—	—	—	—	
2-Row	—	0.7	0.8	1.0	1.2	1.3	1.5	1.6	1.7	1.9	2.0	2.1	2.0	2.6	2.4	3.6	3.6	3.6	3.6	4.6	5.5	—	—	—	—	
<b>Bypass Face Area</b>																										
1-Row	0.2	0.3	0.5	0.6	0.8	0.9	0.9	1.1	1.1	1.4	1.0	1.6	1.5	2.0	1.8	2.1	2.3	2.3	2.7	2.9	3.6	4.2	4.9	5.5	6.3	
2-Row	0.4	0.7	0.9	1.2	1.7	1.9	1.8	2.3	2.1	2.9	2.0	3.3	3.0	4.1	3.6	4.2	4.5	4.5	5.4	5.9	7.2	8.4	9.9	11.0	12.6	
<b>Integral Bypass Face Area</b>																										
1-Row	—	0.3	0.5	0.6	0.6	0.7	0.5	0.6	0.5	0.8	0.9	0.8	1.0	1.2	1.3	1.7	1.6	1.6	1.8	2.4	3.0	3.4	4.3	4.7	5.6	
2-Row	—	0.6	0.9	1.2	1.2	1.4	1.0	1.2	1.1	1.7	1.8	1.7	1.9	2.3	2.5	3.3	3.2	3.3	3.6	4.8	5.9	6.8	8.5	9.4	11.3	
3-Row	—	0.8	1.4	1.8	1.8	2.0	1.5	1.9	1.6	2.5	2.6	2.5	2.9	3.5	3.8	5.0	4.7	4.9	5.3	7.1	8.9	10.3	12.8	14.1	16.9	

NOTE: One gallon of water weighs 8.33 lb.

DRY COIL WEIGHTS (lb)

COIL TYPE	FACE AREA	ROWS	FPI	39M UNIT SIZE																									
				03W	06W	08W	10W	12W	14W	16T	17W	18T	21W	22T	25W	25T	30W	30T	35T	36W	37T	40W	50W	61W	72W	85W	96W	110W	
CHILLED WATER OR DIRECT EXPANSION	LARGE	4	8	50	85	110	143	182	207	219	244	256	309	317	353	355	437	428	503	528	546	576	728	884	1043	1229	1386	1584	
			11	52	89	115	149	190	215	228	254	267	320	328	330	367	370	455	446	523	550	568	600	758	921	1087	1280	1444	1650
			14	54	92	119	155	197	224	237	264	278	335	344	382	385	473	463	544	572	591	624	789	958	1130	1331	1502	1716	
		6	8	70	120	154	200	255	289	306	341	359	432	444	494	497	612	599	704	739	764	806	1019	1238	1461	1720	1940	2218	
			11	73	124	160	209	265	301	319	355	374	450	463	514	518	637	624	733	770	796	840	1062	1289	1521	1792	2021	2310	
			14	76	129	167	217	276	313	331	370	389	468	481	535	539	663	649	762	801	828	874	1104	1341	1582	1863	2102	2402	
		8	8	90	154	198	258	328	372	393	439	461	556	571	635	639	787	770	905	950	982	1037	1310	1591	1878	2211	2495	2851	
			11	94	160	206	268	341	387	410	457	480	579	595	661	666	819	802	942	990	1023	1080	1365	1658	1956	2303	2599	2970	
			14	98	166	215	279	355	403	426	475	500	602	619	688	693	852	834	980	1030	1064	1123	1420	1724	2034	2396	2703	3089	
		10	8	107	182	235	305	388	441	466	520	547	659	677	753	758	932	913	1072	1126	1164	1229	1553	1886	2226	2621	2957	3379	
			11	111	190	244	318	404	459	486	542	569	686	705	784	789	971	951	1117	1173	1213	1280	1618	1964	2318	2730	3080	3520	
			14	116	197	254	331	421	477	505	563	592	714	733	815	821	1010	989	1161	1220	1261	1331	1682	2043	2411	2839	3203	3661	
	MEDIUM	4	8	35	60	80	104	143	177	171	195	215	260	259	296	270	368	325	402	432	443	528	572	728	856	1008	1134	1296	
			11	36	62	83	108	149	184	178	203	224	271	269	308	281	383	338	419	450	461	550	596	758	892	1050	1181	1350	
			14	38	64	87	113	155	192	185	211	233	282	280	321	292	399	352	436	468	479	572	620	789	927	1092	1229	1404	
		6	8	49	83	112	146	200	248	239	273	301	364	362	414	377	515	454	563	605	620	739	801	1019	1198	1411	1588	1814	
			11	51	87	117	152	209	258	249	284	314	379	377	432	393	537	473	586	630	645	770	834	1062	1248	1470	1654	1890	
			14	53	90	121	158	217	268	259	296	326	394	392	449	409	558	492	786	836	847	1001	1115	1450	1669	1966	2211	2527	
		8	8	63	107	144	187	257	319	308	351	387	468	465	533	485	662	584	724	778	797	950	1030	1310	1541	1814	2041	2333	
			11	66	112	150	195	268	332	321	366	404	488	485	555	505	690	608	758	810	830	990	1073	1365	1605	1890	2126	2430	
			14	68	116	156	203	279	345	333	380	420	507	504	577	526	718	633	810	842	863	1030	1115	1450	1669	1966	2211	2527	
		10	8	75	127	171	222	305	378	365	416	459	555	551	631	575	785	692	858	922	944	1126	1220	1553	1826	2100	2419	2765	
			11	78	132	178	231	318	393	380	433	478	578	574	658	599	818	721	893	960	983	1173	1271	1618	1902	2240	2520	2880	
			14	81	138	185	240	330	409	395	451	497	601	597	684	623	850	750	929	998	1023	1220	1322	1682	1978	2300	2621	2995	
SMALL	4	8	—	51	60	78	91	103	114	130	133	146	153	167	159	207	192	285	288	280	288	364	442	—	—	—	—		
		11	—	53	63	81	95	108	119	135	139	152	159	173	166	216	200	297	300	292	300	379	460	—	—	—	—		
		14	—	55	65	85	99	112	124	141	144	158	165	180	173	224	208	308	312	304	312	394	479	—	—	—	—		
	6	8	30	51	70	91	130	148	143	179	164	228	200	259	233	322	280	335	364	354	432	468	572	669	788	882	1008		
		11	31	53	73	95	135	154	148	186	171	237	208	270	242	335	292	349	375	369	450	488	596	697	820	919	1050		
		14	33	55	76	99	141	160	154	194	178	246	216	281	252	349	304	363	390	384	468	507	620	724	853	956	1092		
	8	8	42	71	98	127	182	207	200	250	230	319	281	363	326	451	392	469	504	496	605	655	801	936	1103	1235	1411		
		11	44	74	102	133	190	215	208	261	239	332	291	378	339	470	409	489	525	516	630	683	834	975	1148	1286	1470		
		14	46	77	106	138	197	224	216	271	249	345	303	393	353	488	425	508	546	537	655	710	868	1014	1194	1338	1529		
	10	8	54	92	126	164	234	266	257	322	295	410	360	466	419	580	504	603	648	637	778	842	1030	1204	1418	1588	1814		
		11	56	96	131	171	244	277	267	335	308	427	375	486	436	604	525	628	675	664	810	878	1073	1254	1477	1654	1890		
		14	59	99	137	177	254	288	278	349	320	444	390	505	456	628	546	653	702	690	842	913	1115	1304	1536	1720	1966		
HOT WATER	LARGE	1	8	17	28	37	48	61	69	73	81	85	103	106	118	146	143	168	176	182	192	243	295	348	410	462	528		
			11	17	30	38	50	63	72	76	85	89	107	110	122	123	152	149	174	183	189	200	253	307	362	427	481	550	
			14	18	31	40	52	66	75	79	88	93	112	115	127	128	158	154	181	191	197	208	263	319	377	444	501	572	
	2	8	23	40	51	67	85	96	102	114	120	144	148	165	166	204	200	235	246	255	269	340	413	487	573	647	739		
		11	24	41	53	70	88	100	106	118	125	150	154	171	173	212	208	244	257	265	280	350	430	507	597	674	770		
		14	25	43	56	72	92	104	110	123	130	156	160	178	180	221	216	254	267	276	291	368	447	527	621	701	801		
	4	8	50	85	110	143	182	207	—	244	—	309	—	353	—	437	—	528	—	576	728	884	1043	1229	1386	1584			
		11	52	89	115	149	190	215	—	254	—	322	—	367	—	455	—	550	—	600	758	921	1087	1280	1444	1650			
		14	54	92	119	155	197	224	—	264	—	335	—	382	—	473	—	572	—	624	789	958	1130	1331	1502	1716			
	MEDIUM	1	8	12	20	27	35	48	59	57	65	72	87	86	99	90	123	108	134	144	148	176	191	243	285	336	378	432	
			11	12	21	28	36	50	61	59	68	75	90	90	103	94	128	113	140	150	154	183	199	253	297	350	394	450	
			14	13	21	29	38	52	64	62	70	78	94	93	107	97	133	117	145	156	160	191	207	263	309	364	410	468	
2		8	16	28	37	49	67	83	80	91	100	121	121	138	126	172	151	188	202	207	246	267	340	399	470	529	605		
		11	17	29	39	51	70	86	83	95	105	126	126	144	131	179	158	195	210	215	257	278	354	416	490	551	630		
		14	18	30	40	53	72	89	86	99	109	131	131	150	136	186	164	203	218	224	267	289	368	433	510	573	655		
4		8	35	60	80	104	143	177	—	195	—	260	—	296	—	368	—	432	—	528	572	728	884	1043	1229	1386	1584		
		11	36	62	83	108	149	184	—	203	—	271	—	308	—	383	—	450	—	550	596	758	921	1087	1280	1444	1650		
		14	38	64	87	113	155	192	—	211	—	282	—	321	—	399	—	468	—	572	620	789	958	1130	1331	1502	1716		
SMALL		1	8	—	17	20	26	30	34	38	43	44	49	51	56	53	69	64	95	96	93	96	121	147	—	—	—	—	
			11	—	18	21	27	32	36	40	45	46	51	53	58	55	72	67	99	100	97	100	126	153	—	—	—	—	
			14	—	18	22	28	33	37	41	47	48	53	55	60	58	75</												



**ELECTRICAL DATA - PREMIUM EFFICIENCY EISA COMPLIANT MOTORS**

**ODP T-FRAME MOTORS - 1800 RPM**

MOTOR HP	FLA FOR 3-PHASE, 60 Hz VOLTAGES				EFF. (%)	NEMA FRAME
	208	230	460	575		
1	3.1	2.8	1.4	1.1	85.5	143T
1.5	4.6	4.2	2.1	1.7	86.5	145T
2	6.1	5.6	2.8	2.2	86.5	145T
3	8.6	7.8	3.9	3.1	89.5	182T
5	14.3	13.0	6.5	5.2	89.5	184T
7.5	20.8	18.8	9.4	7.5	91.0	213T
10	27.3	24.7	12.4	9.9	91.7	215T
15	39.8	36.0	18.0	14.4	93.0	254T
20	53.1	48.0	24.0	19.2	93.0	256T
25	65.5	59.3	29.6	23.7	93.6	284T
30	77.8	70.4	35.2	28.2	94.1	286T
40	103.8	93.8	46.9	37.5	94.1	324T
50	128.6	116.3	58.2	46.5	94.5	326T
60	152.7	138.1	69.1	55.2	95.0	364T
75	190.9	172.6	86.3	69.1	95.0	365T
100	252.4	228.3	114.1	91.3	95.4	404T
125	—	—	142.7	114.1	95.4	405T
150	—	—	169.8	135.8	95.8	444T

**ODP T-FRAME MOTORS - 3600 RPM**

MOTOR HP	FLA FOR 3-PHASE, 60 Hz VOLTAGES				EFF. (%)	NEMA FRAME
	208	230	460	575		
1	3.9	3.5	1.8	1.4	77.0	143T
1.5	4.9	4.4	2.2	1.8	84.0	143T
2	6.3	5.7	2.8	2.3	85.5	145T
3	9.4	8.5	4.3	3.4	85.5	145T
5	15.4	13.9	6.9	5.6	86.5	182T
7.5	22.0	19.9	9.9	8.0	88.5	184T
10	28.7	25.9	13.0	10.4	89.5	213T
15	42.4	38.3	19.1	15.3	90.2	215T
20	55.5	50.2	25.1	20.1	91.0	254T
25	68.3	61.8	30.9	24.7	91.7	256T
30	82.0	74.1	37.1	29.6	91.7	284T
40	107.6	97.3	48.7	38.9	92.4	286T
50	132.8	120.1	60.0	48.0	93.0	324T
60	157.3	142.3	71.1	56.9	93.6	326T
75	196.6	177.8	88.9	71.1	93.6	364T
100	262.2	237.1	118.6	94.8	93.6	365T
125	—	—	146.6	117.3	94.1	404T
150	—	—	176.0	140.8	94.1	405T

**TEFC T-FRAME MOTORS - 1800 RPM**

MOTOR HP	FLA FOR 3-PHASE, 60 Hz VOLTAGES				EFF. (%)	NEMA FRAME
	208	230	460	575		
1	3.1	2.8	1.4	1.1	85.5	143T
1.5	4.6	4.2	2.1	1.7	86.5	145T
2	6.1	5.6	2.8	2.2	86.5	145T
3	8.6	7.8	3.9	3.1	89.5	182T
5	14.3	13.0	6.5	5.2	89.5	184T
7.5	20.5	18.5	9.3	7.4	91.7	213T
10	27.3	24.7	12.4	9.9	91.7	215T
15	40.4	36.5	18.2	14.6	92.4	254T
20	53.1	48.0	24.0	19.2	93.0	256T
25	65.5	59.3	29.6	23.7	93.6	284T
30	78.7	71.1	35.6	28.5	93.6	286T
40	103.8	93.8	46.9	37.5	94.1	324T
50	128.6	116.3	58.2	46.5	94.5	326T
60	152.7	138.1	69.1	55.2	95.0	364T
75	189.3	171.2	85.6	68.5	95.4	365T
100	252.4	228.3	114.1	91.3	95.4	405T
125	—	—	142.7	114.1	95.4	444T
150	—	—	169.8	135.8	95.8	445T

**TEFC T-FRAME MOTORS - 3600 RPM**

MOTOR HP	FLA FOR 3-PHASE, 60 Hz VOLTAGES				EFF. (%)	NEMA FRAME
	208	230	460	575		
1	3.9	3.5	1.8	1.4	77.0	143T
1.5	4.9	4.4	2.2	1.8	84.0	143T
2	6.3	5.7	2.8	2.3	85.5	145T
3	9.2	8.3	4.2	3.3	86.5	182T
5	14.7	13.3	6.6	5.3	88.5	184T
7.5	21.5	19.5	9.7	7.8	89.5	213T
10	28.2	25.5	12.8	10.2	90.2	215T
15	41.6	37.6	18.8	15.1	91.0	254T
20	55.5	50.2	25.1	20.1	91.0	256T
25	68.3	61.8	30.9	24.7	91.7	284T
30	82.0	74.1	37.1	29.6	91.7	286T
40	107.6	97.3	48.7	38.9	92.4	324T
50	132.8	120.1	60.0	48.0	93.0	326T
60	157.3	142.3	71.1	56.9	93.6	364T
75	196.6	177.8	88.9	71.1	93.6	365T
100	259.4	234.6	117.3	93.8	94.1	405T
125	—	—	143.9	115.1	95.0	444T
150	—	—	172.6	138.1	95.0	445T

**LEGEND**

- EFF.** — Efficiency
- EISA** — Energy Independence and Security Act of 2007
- FLA** — Full Load Amps
- NEMA** — National Electrical Manufacturers Association
- ODP** — Open Drip Proof
- TEFC** — Totally Enclosed Fan Cooled

**NOTES:**

1. Approximate motor full load amps listed. Actual motor full load amps can be found on the motor nameplate.
2. Motor voltage and availability is controlled by **AHUBuilder** software.

## 39M Indoor Air Handler Units

### HVAC Guide Specifications

Size Range: **1,500 to 60,500 Nominal Cfm**

Carrier Model Number: **39MN — Indoor Unit**

#### Part 1 — General

##### 1.01 QUALITY ASSURANCE

###### A. Manufacturer Qualifications:

Company specializing in manufacturing the products specified in this section with minimum of five years documented experience.

→ B. The management system governing the manufacturing of this product is ISO (International Organization for Standardization) 9001:2008 certified.

C. Air-handling unit assembly shall have UL (Underwriters Laboratories) 1995 certification for safety, including use with electric heat.

D. Products requiring electric connection shall be listed and classified by ETL and CSA (Canadian Standards Association) as suitable for the purpose specified and indicated.

E. Coil performance shall be certified in accordance with AHRI (Air-Conditioning, Heating, and Refrigerating Institute) Standard 410, latest edition.

F. Unit performance shall be rated in accordance with AHRI Standard 430 for Central Air Handling Units and subject to verification of rating accuracy by AHRI-sponsored, third party testing. Units shall meet NFPA (National Fire Protection Association) 90A requirements.

##### 1.02 DELIVERY, STORAGE AND PROTECTION

A. All indoor units, painted or unpainted, shall be completely shrink-wrapped from the factory for protection during shipment. Tarping of bare units is unacceptable.

B. Inspect for transportation damage and store in clean dry place and protect from weather and construction traffic. Handle carefully to avoid damage to components, enclosures, and finish.

##### 1.03 START-UP REQUIREMENTS

Do not operate units until ductwork is clean, filters are in place, bearings lubricated, condensate properly trapped, piping connections verified and leak tested, belts aligned and tensioned, all shipping braces have been removed, and fan has been test run under observation.

#### Part 2 — Products

##### 2.01 GENERAL DESCRIPTION

A. Units shall ship in the number of sections necessary to meet project requirements and shall ship in as many splits as specified in selection software. Split options as follows:

1. Shipped in sections — shipping split.
2. Shipped assembled — base rail break (ship attached).
3. Shipped assembled — solid base rail.

B. Unit shall be factory-supplied, central station air handler. The air-handling unit may consist of a fan with the following factory-installed components as indicated on the equipment schedule.

###### 1. Mixing Box Section:

- a. No filter tracks.
- b. With flat filter tracks.
- c. With angle filter tracks.
- d. With bag cartridge filter tracks.
- e. With exhaust air dampers.

###### 2. Air Mixer Section.

###### 3. Exhaust Box Section.

###### 4. Integral Face and Bypass Section:

- a. With hot water coil.
- b. With steam coil.

###### 5. Internal Face and Bypass Damper Section.

###### 6. External Face and Bypass Damper Section.

###### 7. Plenum Section:

- a. With drain pan.
- b. No drain pan.

###### 8. Humidifier Section.

###### 9. Blow-Thru Discharge Plenum.

###### 10. Filter Section:

- a. 2-in. flat filters.
- b. 4-in. flat filters.
- c. 4-in. flat filters with 2-in. pre-filters.
- d. 2-in. angle filters.
- e. 4-in. angle filters.
- f. Side loading 12-in. bag/cartridge filters with 2-in. pre-filters.
- g. Side loading 30-in. bag/cartridge filters with 2-in. pre-filters.
- h. Face loading bag/cartridge filters without pre-filters. Maximum bag/cartridge filter length is limited to access/plenum sections placed after this section.
- i. Face loading HEPA (high-efficiency particulate air) bag/cartridge filters without pre-filters.

###### 11. Gas Heating Section.

###### 12. Coil Section:

- a. Chilled water coil.
- b. Direct expansion coil.
- c. Hot water coil.
- d. Steam coil.
- e. Electric coil.

###### 13. Multi-Zone Cooling/Heating Coil Section:

- a. With dampers.
- b. No dampers (for dual duct).

###### 14. Energy Recovery Wheel Section.

15. Fan Section:
  - a. Horizontal draw-thru (supply, return, and exhaust).
  - b. Horizontal blow-thru (with integral diffuser on supply fan only).
  - c. Plenum fan (with optional exhaust air damper on return fan only).
  - d. Vertical draw-thru.

## 2.02 CASING

### A. Construction:

1. Unit shall be constructed of a complete frame with easily removable panels. Removal of any panel shall not affect the structural integrity of the unit.
2. All units shall be supplied with 14-gage or heavier, G-90 galvanized steel base rails. Bolt-on legs are NOT acceptable. Perimeter lifting lugs for overhead lifting shall be provided on each shipping section. Slings in place of lifting lugs shall not be acceptable.
3. Unit shall be thermally broken to minimize the conduction path from the inside of the casing to the outside.
4. Casing panels (top, sides, and bottom) shall be constructed of galvanized steel, and shall have one of the following exterior finishes as specified:
  - a. Pre-painted with a baked enamel finish passing 500-hour salt spray test (ASTM [American Society of Mechanical Engineers] B-117) for pre-painted steel and 125-hour marine level 1 profession test (ASTM G-85.A5) for pre-painted steel.
  - b. Unpainted G-90 galvanized steel.
5. Casing panels (top, sides, and bottom) shall be constructed of galvanized steel or stainless steel, and shall have one of the following interior finishes as specified:
  - a. G-90 pre-coated galvanized steel with a silver zeolite antimicrobial material registered by the US EPA (Environmental Protection Agency) for use in HVAC applications.
  - b. Unpainted G-90 galvanized steel.
  - c. Unpainted 304 stainless steel.
6. Casing panels (top, sides, and bottom) shall be one piece, double-wall construction with insulation sealed between the inner and outer panels. Panel assemblies shall not carry an R-value of less than 13.
7. Casing deflection shall not exceed a L/240 ratio when subject to an internal pressure of  $\pm$  8-in. wg and shall exhibit no permanent deformation at  $\pm$  9-in. wg. L is defined as the longest linear panel or cabinet length (measured to AHRI 1350 Cd level 2).

8. Casing leakage rate shall be less than 1% at 8 in. wg of nominal unit airflow or 50 cfm, whichever is greater. Leakage rate shall be tested and documented on a routine basis on random production units. Optionally, factory witness leak testing and/or test reports shall be available.
  9. Side panels shall be easily removable for access to unit and shall seal against a full perimeter automotive style gasket to ensure a tight seal.
  10. The panel retention system shall comply with UL 1995 which states all moving parts (for example, fan blades, blower wheels, pulleys, and belts) that, if accidentally contacted, could cause bodily injury, shall be guarded against accidental contact by an enclosure requiring tools for removal.
  11. Accessibility options shall be as follows:
    - a. Hinged double-wall access door on either side with removable access panel(s) on the other side.
    - b. Hinged double-wall access doors on both sides.
    - c. Removable double-wall access panels on both sides.
  12. Depending on the options selected and the remaining available space inside each section, the following options may be available:
    - a. Thermal pane reinforced glass viewports shall be factory-installed on the access panel(s) or door(s) of the section.
    - b. Marine lights shall be factory installed with or without GFCI (ground fault circuit interrupter) convenience outlets.
  13. Fan supports, structural members, panels, or flooring shall not be welded, unless aluminum, stainless steel, or other corrosion-resistant material is used. Painted welds on unit exterior steel or galvanized steel are not acceptable.
  14. All coil sections shall be doublewall construction with insulation sealed between the inner and outer panels. Panel assemblies shall not carry an R-value of less than 13. Single height coil sections shall have removable frame sections to facilitate vertical coil extraction.
  15. Blow-thru sections shall have a diffuser plate as an integral part of the fan section.
- B. Access Doors:
- Access doors shall be one piece, double-wall construction with insulation sealed between the inner and outer panels. Panel assemblies shall not carry an R-value of less than 13.
- C. Drain Pans:
- Drain pans shall be insulated double-wall galvanized or stainless steel construction. The pan shall be sloped toward the drain connection. Drain pan shall have 1 $\frac{1}{2}$ -in. MPT connection exiting through the hand side or opposite side of the casing as specified. One drain outlet shall be supplied for each cooling

coil section. Drain pan shall allow no standing water and comply with ASHRAE (American Society of Heating, Refrigeration and Air-Conditioning Engineers, Standard 62.1-2010. Where 2 or more coils are stacked in a coil bank, intermediate drain pans shall be provided and the condensate shall be piped to the bottom drain pan. The bottom coil shall not serve as a drain path for the upper coil.

## 2.03 FANS

### A. General:

1. Forward-curved fan sections shall have one double-width double-inlet (DWDI) fan wheel and scroll. They shall be constructed of galvanized steel with baked enamel. They shall be designed for continuous operation at the maximum rated fan speed and motor horsepower. Fans shall have an AMCA class rating corresponding to the static pressure at which the fan is designed to operate (Class I or II). Completed fan assembly shall be dynamically balanced in accordance with AHRI Guideline G and ANSI S2.19 at design operating speed using contract drive and motor if ordered.
2. Airfoil fan sections shall have one DWDI airfoil fan wheel and scroll. Airfoil blades shall be double thickness design constructed of heavy gage, high strength steel or aluminum continuously welded to the backplate and the spun inlet flange. Entire fan assembly shall be cleaned, primed and painted with alkyd enamel, except for an aluminum fan wheel when supplied. Fans shall have an AMCA class rating corresponding to the static pressure at which the fan is designed to operate (Class I or II). Completed fan assembly shall be dynamically balanced to minimum grade of G 6.3 per ANSI/AMCA 204 at design operating speed using contract drive and motor if ordered.
3. Belt drive plenum fan sections shall have one single-width single-inlet (SWSI) airfoil fan wheel. Airfoil blades shall be double thickness design constructed of heavy gage, high strength steel or aluminum continuously welded to the backplate and the spun inlet flange. Entire fan assembly shall be cleaned, primed and painted with alkyd enamel, except for an aluminum fan wheel when supplied. They shall be designed for continuous operation at the maximum rated fan speed and motor horsepower. Fans shall have an AMCA class rating corresponding to the static pressure at which the fan is designed to operate (Class I or II). Completed fan assembly shall be dynamically balanced to minimum grade of G 6.3 per ANSI/AMCA 204 at design operating speed using contract drive and motor if ordered.
4. Direct drive plenum fan sections shall have the option of one, two, four, or six single width single inlet (SWSI) airfoil fan wheel(s). Airfoil blades shall be double thickness design

continuously welded to the back plate and the front plate. Fan wheel shall be constructed of aluminum. Airfoil blades shall be aluminum extrusions and shall be top welded to the back plate and front plate of the wheel. Fan wheel shall be dynamically balanced per ISO standard 1940 quality grade G6.3.

5. Fan assembly vibration shall not exceed 0.248 in. per second when mounted on active isolators. Vibration shall be measured in both vertical and horizontal directions at the specified fan operating speed using specified motor. For testing purposes, accelerometers shall be mounted on the motor near the bearing locations and removed before shipment.
  6. All fan sled components shall provide corrosion protection to pass 100-hour salt spray test per ASTM B-117.
  7. Fan wheels shall be keyed to the shaft and shall be designed for continuous operation at maximum rated fan speed and motor horsepower. Fan wheels and shafts shall be selected with a maximum operating speed 25% below the first critical.
  8. Belt drive fan motor shall be mounted within the fan section casing on slide rails equipped with adjusting screws. Motor shall be premium efficiency, open drip-proof or totally enclosed fan cooled NEMA (National Electrical Manufacturers Association) Design A or B with size and electrical characteristics as shown on the equipment schedule. Motor shall be mounted on a horizontal flat surface and shall not be supported by the fan or its structural members. All three-phase motors shall have a  $\pm 10\%$  voltage utilization range and a 1.15 minimum service factor. Motor shall be compliant with the Energy Independence and Security Act (EISA) of 2007 where applicable. Single-phase motors shall be available up to and including 5 hp.
- B. Performance Ratings:  
Fan performance shall be rated and certified in accordance with AHRI Standard 430, latest edition.
- C. Sound Ratings:  
Manufacturer shall submit first through eighth octave sound power for fan discharge and casing radiated sound. Sound ratings shall be tested in accordance with AHRI 260.
- D. Mounting:  
Fan scroll, wheel, shaft, bearings, drives, and motor shall be mounted on a common base assembly. The base assembly is isolated from the outer casing with factory-installed isolators and rubber vibration absorbent fan discharge seal. A canvas style duct connection between fan discharge and cabinet is not acceptable. Units shall use 2-in. deflection spring isolators.



#### E. Fan Accessories:

1. Forward-curved fans:
  - a. Variable frequency drives with or without bypass.
  - b. Magnetic motor starters.
  - c. Motor disconnects.
  - d. Airflow measuring piezo ring.
  - e. Piezo ring transducer.
  - f. Motor shaft grounding ring.
  - g. Belt guards.
  - h. Inlet screen.
2. Airfoil Fans:
  - a. Variable frequency drives with or without bypass.
  - b. Magnetic motor starters.
  - c. Motor disconnects.
  - d. Airflow measuring piezo ring.
  - e. Piezo ring transducer.
  - f. Motor shaft grounding ring.
  - g. Belt guards.
  - h. Inlet screen.
3. Belt Drive Plenum Fans:
  - a. Variable frequency drives with or without bypass.
  - b. Magnetic motor starters.
  - c. Motor disconnects.
  - d. Airflow measuring piezo ring.
  - e. Piezo ring transducer.
  - f. Motor shaft grounding ring.
  - g. Inlet screen and wheel cage.
4. Direct Drive Plenum Fans:
  - a. Variable frequency drives.
  - b. Motor protection box for motor current protection with a single VFD driving multiple motors.
  - c. Airflow measuring piezo ring.
  - d. Piezo ring transducer.
  - e. Motor shaft grounding ring.
  - f. Inlet guard.
  - g. Blank off plate.
  - h. Backdraft dampers.

Optional backdraft damper blades shall be 6063-T5 extruded aluminum channel with galvanized steel braces and extruded vinyl blade seals. Blades shall be mechanically fastened to axle rod rods rotating in corrosion-resistant, synthetic bearings. Blades open at 0.12 in. wg and are fully open at 0.2 in. wg.

#### F. Flexible Connection:

The base assembly is isolated from the outer casing with factory-installed isolators and rubber vibration absorbent fan discharge seal. A canvas style duct connection between fan discharge and cabinet is not acceptable.

#### 2.04 BEARINGS AND DRIVES

##### A. Bearings:

Self-aligning, grease lubricated, anti-friction with lubrication fittings extended to drive side of fan section. Optional grease fittings extended to the exterior of the casing are available. All bearing life calculations shall be done in accordance with ABMA 9 for ball bearings and ABMA 11 for roller bearings.

1. Size 03 to 110 forward-curved fans: Cartridge type bearings for Class I fans. Heavy-duty pillow block type, self-aligning, regreasable ball or roller type bearings selected for a minimum average life ( $L_{50}$ ) of 200,000 hours or optionally for an ( $L_{50}$ ) of 500,000 hours.
2. Size 03 to 110 airfoil fans: Heavy-duty pillow block type, self-aligning, regreasable ball or roller type bearings selected for a minimum average life ( $L_{50}$ ) of 200,000 hours or optionally for an ( $L_{50}$ ) of 500,000 hours.
3. Size 06 to 110 belt-drive plenum fans: Heavy-duty pillow block type, self-aligning, regreasable roller type bearings selected for a minimum average life ( $L_{50}$ ) of 200,000 hours or optionally for an ( $L_{50}$ ) of 500,000 hours.

##### B. Shafts:

Fan shafts shall be solid steel, turned, ground, polished and coated with a rust inhibitor.

##### C. V-Belt Drive:

Drive shall be designed for a minimum 1.2 service factor as standard with a 1.5 service factor option and/or a factory-supplied extra set of belts. Drives shall be fixed pitch with optional variable pitch for motors 15 hp and less. All drives shall be factory mounted, with sheaves aligned and belts properly tensioned.

#### 2.05 COILS

- A. All water, steam and direct expansion (DX) refrigerant coils shall be provided to meet the scheduled performance. All coil performance shall be certified in accordance with AHRI Standard 410. All water and direct expansion coils shall be tested at 450 psig air pressure. Direct expansion coils shall be designed and tested in accordance with ANSI/ASHRAE 15 Safety Code for Mechanical Refrigeration (latest edition). Factory-supplied  $1/2$ -in. OD coils shall be covered under the standard product one-year limited warranty. All steam coils, integral face and bypass coils and  $5/8$ -in. OD coils shall be warranted for a period not in excess of 12 months from their shipment from the manufacturer. Coil epoxy coating shall be covered under a 5-year limited warranty from the date of shipment from the manufacturer.

## B. General Fabrication:

1. All water and refrigerant coils shall have minimum  $\frac{1}{2}$ -in. OD copper tubes mechanically expanded into fins to ensure high thermal performance with lower total flow and pumping requirements. Minimum tube wall thickness shall be 0.016 inches. Optional tube wall thickness of 0.025 in. shall be supplied, if specified.
2. Optionally, water coils shall have minimum  $\frac{5}{8}$ -in. OD copper tubes mechanically expanded into fins to ensure high thermal performance with lower total flow and pumping requirements. Minimum tube wall thickness shall be 0.020 inches. Optional tube wall thickness of 0.035 in. shall be supplied, if specified.
3. Aluminum plate fin type with belled collars. Optional copper plate fins shall be supplied, if specified. Fin type shall be sine wave construction.
4. Aluminum-finned coils shall be supplied with die-formed casing and tube sheets of mill galvanized steel or stainless steel as specified. Copper-finned coils shall be supplied with stainless steel casing and tube sheets.

## C. Hydronic Heating and Cooling Coils:

1. Headers shall be constructed of steel with steel MPT connections. Headers shall have drain and vent connections accessible from the exterior of the unit. Optional non-ferrous headers and red brass MPT connections shall be supplied if specified.
2. Configuration: Coils shall be drainable, with non-trapping circuits. Coils will be suitable for a design working pressure of 300 psig at 200 F.

## D. Steam Distribution (Non-Freeze Type) Heating Coils:

1. Headers shall be steel with MPT connections.
2. Inner steam distributing tubes shall be  $\frac{5}{8}$ -in. OD, 0.020 in. wall thickness, located within 1 in. OD, 0.030 in. wall outer condensing tubes. Working pressure shall be 175 psig at 400 F.
3. Inner steam distributing tubes shall be  $\frac{3}{8}$ -in. OD, 0.020 in. wall thickness, located within  $\frac{5}{8}$ -in. OD, 0.035 in. wall outer condensing tubes. Working pressure shall be 175 psig at 400 F.

## E. Integral Face and Bypass Coils:

1. Sizes 03-14 shall have horizontal steam or hot water coils with a tubewall thickness of not less than 0.020 inches. Tubes shall be mechanically expanded into die formed collars formed in aluminum plate type fins.
2. Sizes 17-110 shall have vertical steam or hot water coils with a tubewall thickness of not less than 0.035 inches. Fins shall be spiral edge-wound copper. Tubes shall be free-floating for

thermal expansion and contraction without the use of offset bends or floating headers.

## F. Refrigerant Coils:

1. Headers shall be constructed of copper with brazed joints.
2. Standard circuiting selections include:
  - a. Single distributor arrangement for sizes 03-17.
  - b. Row split intertwined, multiple distributor arrangement for sizes 03-110.
  - c. Face split, multiple distributor arrangement for sizes 03-110.
3. Thermal expansion valves, replaceable nozzle, brass refrigerant distributors and seamless copper distribution tubes are factory supplied to ensure uniform flow.
4. Submittals must include a DX coil and condensing unit cross plot to show that the coil and condensing unit capacity match at the rated design conditions.

## G. Electric Heating Section:

1. The electric heater casing is constructed of galvanized steel. Heater control box access door shall be mounted on the designated hand side of the unit. Element construction as follows:
  - a. Open-wire type, 80% nickel, 20% chromium resistance coils, insulated by Steatite bushings and supported in a galvanized steel frame. Bushings shall be recessed into embossed openings and stacked into supporting brackets, spaced no more than 4-in. centers. Thermal cutouts for overtemperature protection shall be provided to meet UL and NEC requirements. Maximum element heating density shall be 55 watts/sq inch.
    - 1) Contactor control - electric heaters up through 60 kW shall have 3 stages of control, beyond 60 kW shall have 6 stages of control.
    - 2) SCR control - electric heaters up through a maximum of 90 amps are available with full SCR control. The entire heater is modulated to achieve the proportional control based on a 0 to 10 volt DC or 4 to 20 mA control signal.
    - 3) Vernier control - the heater has full modulating control of the first circuit of heat, all of which is rated at equal kW increments. There is a minimum of 3 circuits for this type of control. These stage increments are turned on and off by a step controller. As each stage fulfills the demand for heat, the SCR increment is used as a fully modulating filler between stages. This end output is a fully proportional control of the electric heater based on a 0 to 10 volt DC or 4 to 20 mA control signal.

b. Sheathed type, 80% nickel, 20% chromium resistance coils, suspended in a magnesium oxide insulator fill within a tubular steel sheath/brazed fin assembly. Silicone rubber end seals shall prevent contamination of the interior, and the exterior shall be protected from corrosion by a high temperature aluminum coating. Thermal cutouts for overtemperature protection shall be provided to meet UL and NEC requirements. Maximum element heating density shall be 55 watts/sq inch.

- 1) Contactor control - electric heaters up through 60 kW shall have 3 stages of control, beyond 60 kW shall have 6 stages of control.
2. The manufacturer shall furnish an integral control box containing thermal cutouts, primary control, subcircuit fusing, airflow switch, and fused control transformer.
3. Electric heaters shall be UL listed for zero clearance and shall meet all applicable National Electric Code requirements.
4. Units with electric heat sections shall be listed under UL 1995 Standard for Safety.

## 2.06 GAS HEATING SECTION

A. Indirect fired gas furnace section(s) shall have a minimum thermal efficiency of 80% and incorporate agency listed gas-fired duct furnace(s) per UL, CSA, or ETL for operation on natural or propane gas to the current edition of ANSI Z83.8 or Canadian CSA 2.6 Standard for Gas-Fired Duct Furnaces. Duct furnaces shall be installed on the positive pressure side of the supply fan only.

B. The duct furnace module(s) shall have:

1. 20 gage galvanized steel heat exchanger cabinet.
2. 1 in. thick, minimum 1<sup>1</sup>/<sub>2</sub> lb per cu ft density thermal insulation for the heat exchanger cabinet.
3. Each furnace shall have an induced-draft fan for the removal of flue gases and to keep the heat exchanger at a negative pressure.
4. Air pressure switches to prove air supply for combustion before operation of gas valve.
5. Patented inshot gas burners with integral carryovers.
6. Direct-spark ignition of the gas burners with remote flame sensor to prove carryover across all burners.
7. A listed 24-vac redundant combination gas valve including two electric shutoff valves, gas pressure regulator, and a manual shutoff valve per furnace.
8. An automatic reset type high limit switch to limit maximum outlet air temperature to less than 250 F.

9. Manual reset flame rollout switches.

10. Minimum of one 40 va, 24 vac control transformer.

11. 1/8 in. NPT tapped test gage connection in the gas manifold for measuring gas pressure.

12. Union fitting downstream of gas control to facilitate installation and service.

13. Provision for attachment of a vent system to exhaust flue gases to the outdoors.

C. Gas-fired duct furnace(s) provided shall have an 18 gage tubular heat exchanger assembly suitable to withstand 3.0 in. wg total external static pressure without burner flame disturbance and constructed of either:

1. Type 409 stainless steel (0.044 minimum wall thickness) produced to ASTM A268.
2. Type 304L stainless tubes (0.047 minimum wall thickness) produced to ASTM A249.

D. Gas heating section modules shall be listed for application downstream of refrigeration and cooling systems and shall provide means for removal of condensate that occurs in the tubes during cooling operation. Heat exchanger tubes shall have (integral formed dimpled restrictors; formed tubulators) to provide for an unobstructed drainage path and tubes shall be formed to provide a positive pitch to promote condensate drainage. Drainage shall be configured so that burners and burner surfaces are not exposed to condensate.

E. Gas heating section shall incorporate a direct spark ignition control module listed by one of the following: US, CSA, or ETL.

F. Controls shall provide:

1. 100% safety shutoff.
2. A 15-second minimum pre-purge period prior to trial for ignition.
3. High-energy direct spark ignition of main burners.
4. Electronic flame supervision incorporating a 0.8-second flame failure response time.
5. Up to 2 additional ignition retries preceded by an inter-purge period.
6. A minimum 30-second post-purge.
7. Automatic reset after one hour to initiate additional ignition trials if lockout occurs during heat call.
8. An LED indicator light to provide a flash code to identify the operating condition of the control.

G. Gas heating section shall be equipped for operation with 115 vac, single-phase, 60 Hz power supply.

H. All electrical components shall be listed or recognized by UL, CSA, or ETL.

## I. Gas Furnace Control:

1. Single furnace — Operates from 10 to 100% of input from a single analog input of 0 to 10 vdc.
2. Two furnaces in series — Lead unit operates from 20 to 100% of input and secondary unit operates in two-stage operation to achieve overall system input of 10 to 100% from a single analog input of 0 to 10 vdc.
3. Furnace rack systems — Multiple furnaces operate from a single analog input of 0 to 10 vdc with a lead modulating furnace and multiple secondary two-stage furnaces to achieve overall system input of 10 to 100%. (10:1 turndown minimum; most rack systems provide greater than 10:1 turndown.)

J. Electronic modulation — Operates from 10 to 100% of input from a single analog input of 0 to 10 vdc. Heat enable contact (supplied by others) initiates and ends heating cycles. Heating unit incorporates two-speed operation of combustion air blower and two-stage gas valve, signal amplifier and timer relay control.

K. Gas supply pressure to the gas valve inlet shall be 5.0 to 13.5 in. wg for natural gas or 11.0 to 13.5 in. wg for propane gas.

L. Units are orificed for operation up to 2000 ft above sea level unless specified for high altitude operation.

M. Duct furnaces shall be test-fired prior to shipment to verify proper ignition, operation and shutdown and satisfactory operation of all components.

N. Furnaces shall be provided with printed installation and maintenance instructions, burner operating and maintenance instructions, piping and wiring diagrams and installation start-up data sheet.

## 2.07 ENERGY RECOVERY WHEEL

### A. Construction:

1. Wheel sections shall incorporate a rotary wheel in an insulated cassette frame complete with seals, drive motor and drive belt.
2. The wheel shall be coated with silica gel desiccant, permanently bonded without the use of binders or adhesives.
3. The substrate shall be made of a light weight polymer and shall not degrade nor require additional coatings for application in coastal environments.
4. Coated wheel segments shall be washable with detergent or alkaline coil cleaner and water.
5. The silica gel desiccant shall not dissolve nor deliquesce in the presence of water or high humidity.
6. The wheel polymer layers shall be wound continuously with one flat and one structured layer in an ideal parallel plate geometry providing laminar flow and minimum pressure drop.

7. The wheel shall incorporate the channel matrix design and an optional adjustable mechanical purge.

8. The polymer layers shall be captured in a stainless steel wheel frame or aluminum and stainless steel segment frames that provide a rigid and self-supporting matrix.

9. Energy recovery wheels greater than 25 inches in diameter shall be provided with removable wheel segments.

10. Wheel frame shall be a welded hub, spoke and rim assembly of stainless, plated and/or coated steel and shall be self-supporting without the wheel segments in place.

11. Wheel segments shall be removable without the use of tools to facilitate maintenance and cleaning.

12. Wheel bearings shall provide an L-10 life in excess of 400,000 hours.

13. Wheel rim shall be continuous rolled stainless steel and the wheel shall be connected to the shaft by means of taper locks.

14. All diameter and perimeter seals shall be provided as part of the cassette assembly and shall be factory set.

15. Drive belts of stretch urethane shall be provided for wheel rim drive without the need for external tensioners or adjustment.

16. The energy recovery section shall be a UL recognized component for electrical and fire safety. The wheel drive motor shall be UL recognized and mounted in the cassette frame and supplied with a service connector or junction box.

17. Thermal performance shall be AHRI Standard 1060 certified and bear the AHRI Certified Product Seal. Cassettes shall be listed in the AHRI Certified Products Directory and bear the AHRI Certified Product Seal.

18. Wheel shall carry a 5-year parts warranty. This warranty is for all wheel cassette components except the drive motor, which carries the motor manufacturer's warranty.

## 2.08 HUMIDIFIERS

A. The humidifiers shall be of the direct discharge type, using steam from existing steam lines or boilers to be injected into the air plenums for humidification.

B. Each humidifier shall consist of multiple, vertical steam discharge pipes, supported on horizontal header manifolds, spaced to provide the optimum of steam to air contact while minimizing pressure drop. Each humidifier shall be sized to nominally match the air plenum width and height for maximum contact of the discharging steam to the air passing around the vertical steam discharge pipes.

C. The vertical steam discharge pipes shall be constructed of 316 stainless steel. Each pipe shall have

a full-length, inverted slot on each side for steam discharge at 100% air to steam contact. Nozzles and holes have less than 15% air to steam contact and are, therefore, unacceptable.

- D. A full-length stainless steel fishbone shaped baffle shall be used inside the vertical discharge pipe to wick condensate away from the discharge slots and back to the center of the pipe for re-evaporation.
- E. The feeder manifolds shall be constructed of 316 stainless steel, sized to move the steam in a specific mass-flow speed range, for maximum condensate separation. Final condensate separation shall occur inside the feeder manifolds, after the control valve, with the dried steam then injected directly into the vertical discharge pipes.
- F. Insulated uprights provide a cushion of air that reduces both heat gain and condensate formation. Insulated models have nozzles inserted in the uprights to ensure that only dry steam is delivered into the air.
- G. The steam humidifier shall be designed with slip fittings for easy assembly. The steam humidifier shall be designed without plastic nozzles, collars, o-rings or gaskets for zero maintenance.

## 2.09 FILTER SECTIONS

- A. Flat filter sections shall accept either 2-in. or 4-in. filters. Sections shall include side access slide rails. Optional 6-in. filter racks shall be capable of accepting 4-in. final filters. Optional 2 in. pre-filter shall be available.
- B. Angle filter sections shall accept either 2-in. or 4-in. filters of standard sizes, arranged in a horizontal V formation.
- C. Draw-thru bag/cartridge filter sections shall be capable of accepting headered standard size 6-in. to 12-in. deep rigid media or bag filters and a 2-in. pre-filter.
- D. Draw-thru bag/cartridge filter sections shall be capable of accepting headered standard size 12-in. to 30-in. deep rigid media or bag filters and a 2-in. pre-filter.
- E. Blow-thru bag/cartridge filter sections shall contain a face loading filter frame and be capable of accepting standard size 12-in. deep rigid media (headered or box) or bag filters.
- F. Blow-thru HEPA filter sections shall contain a face loading filter frame and be capable of accepting standard size 12-in. deep HEPA box filters.
- G. Differential Pressure Gages:
  1. Housing shall be constructed of a glass filled nylon case and acrylic lens. Exterior finish shall be coated black.
  2. Accuracy shall be  $\pm 5\%$  of full scale throughout range at 70 F.
  3. Pressure limits shall be 30 psig continuous to either pressure connection.
  4. Temperature limits shall be 20 to 120 F.

5. Diameter of dial face shall be 2.33 in.

6. Process connections shall be barbed,  $\frac{3}{16}$ -in. for ID tubing

## 2.10 DAMPERS

- A. Factory-supplied dampers shall be warranted to be free from defects in material and workmanship for a period of 12 months after being installed or placed in service, but in no instance shall the period of warranty be longer than 18 months from the date of the original shipment by the manufacturer.
- B. Mixing boxes, filter-mixing boxes, and exhaust boxes shall have parallel or opposed blades and interconnecting outside-air and return-air dampers.
  1. Standard Dampers:
 

Damper blades shall be constructed of galvanized steel, with blade seals and stainless steel jamb seals. Blades shall be mechanically fastened to axle rods rotating in self-lubricating synthetic bearings. Maximum leakage rate shall be 4 cfm/ft<sup>2</sup> at 1 in. wg differential pressure.
  2. Premium Dampers:
 

Damper blades shall be constructed of galvanized steel with a double-skin airfoil design, with blade seals and stainless steel jamb seals. Blades shall be mechanically fastened to axle rods rotating in self-lubricating synthetic bearings. Maximum leakage rate shall be 2 cfm/ft<sup>2</sup> at 1 in. wg differential pressure.
  3. Outside Air Measurement Dampers:
    - a. Damper frame shall be nominal 4 in. x 1 in. x minimum 0.081 in. and constructed of 6063-T5 extruded aluminum.
    - b. Airflow measuring blades shall be airfoil-shaped, heavy gage anodized 6063-T5 extruded aluminum and fixed in 10 in. x minimum 16 gage galvanized steel frame.
    - c. Jamb seals shall be flexible metal compression type along control damper sides.
    - d. Blade seals shall be neoprene along control damper blade edges.
    - e. Bearings shall be molded synthetic.
    - f. Linkage shall be galvanized steel, concealed in frame.
    - g. Axles shall be minimum  $\frac{1}{2}$ -in. diameter plated steel, hex-shaped, mechanically attached to blade.
    - h. Operating temperature shall be -22 to 140 F.
    - i. Air straightener section shall be aluminum alloy honeycomb contained in 5 in. long, 16 gage galvanized steel sleeve attached to monitoring blade frame.
    - j. Airflow range shall be 400 to 5,000 ft per minute face velocity.
    - k. Maximum leakage rate shall be 2 cfm/ft<sup>2</sup> at 1 in. wg differential pressure.

## C. Integral Face and Bypass Dampers:

1. Integral face and bypass (IFB) coils shall be capable of maintaining a constant air volume, within 5%, shall be capable of maintaining a constant leaving air temperature as entering air conditions vary, and shall be capable of producing mixed leaving air temperatures within 3 ft downstream with a maximum variance in air temperature of 5° F, regardless of damper position.
2. When no heating is required, dampers shall divert air to bypass around heating surface with minimal temperature override.
3. Coil casing, dampers and baffles shall be fabricated from galvanized steel with an option for stainless steel. Coils shall be tested at 300 psig.
4. Integral face and bypass coils shall be provided with a connection point for field-mounted actuator(s), electrical or pneumatic, or can be provided from the factory at an additional cost.
5. Actuator connection point shall be mechanically attached to dampers via linkage mechanisms. Dampers shall be interconnected for operation simultaneously across each face of coil.

## D. Face and Bypass Dampers:

### 1. Internal Face and Bypass Dampers:

Internal face and bypass dampers shall be factory mounted in galvanized steel frame. Damper blades shall be constructed of galvanized steel, with high temperature blade and edge seals. Blades shall be mechanically fastened to axle rods rotating in self-lubricating synthetic bearings. To eliminate blade warping, face dampers shall be sectionalized to limit blade length to 60 in. maximum. Face damper blades shall be opposed and arranged to match coil face with top bypass, and internal linkage.

### 2. External Face and Bypass Dampers:

Face damper shall be factory mounted in galvanized steel frame. Damper blades shall be constructed of galvanized steel, with high temperature blade and edge seals. Blades shall be mechanically fastened to axle rods rotating in self-lubricating synthetic bearings. Bypass damper shall be constructed of galvanized steel, with blade seals and stainless steel jamb seals. Blades shall be mechanically fastened to axle rod rotating in self-lubricating synthetic bearings. Face damper blades shall be opposed with top bypass, and internally mounted linkage.

## E. Multi-Zone Dampers:

Multi-zone dampers shall be factory mounted in galvanized steel frame. Damper blades shall be constructed of galvanized steel with a double-skin airfoil design, with blade seals and stainless steel jamb seals. Blades shall be mechanically fastened to axle rods rotating in self-lubricating synthetic bearings. Maximum leakage rate shall be 11 cfm/ft<sup>2</sup> at

1 in. wg differential pressure. Maximum pressure drop due to dampers shall be no more than 0.40 in. wg. Number of zones shall vary by size of section.

## 2.11 AIR MIXER

Air mixer of 0.081-in. aluminum construction of size, performance and maximum pressure drop indicated. The air mixer shall mix two or more airstreams of differing temperature to within ±6° F of theoretical mixed-air temperature and provide a more uniform air velocity contour entering a downstream filter or coil bank.

## 2.12 UV-C GERMICIDAL LAMPS

A. Emitters and fixtures for UV-C lamps shall be designed for use inside an HVAC system and shall be covered by a 1 year warranty. Individual lamp output shall be measured in an ASME nozzled test apparatus using a 45 F airstream moving at not less than 400 fpm. Lamp output at 253.7 nm shall not be less than 10 μW/cm<sup>2</sup> per inch of arc length measured at a distance of one meter.

B. Power supplies for UV-C lamps shall be a high-efficiency electronic type which are matched to the emitters and are capable of producing the specified output intensity with an input power no more than 80 watts.

C. Fixtures for UV-C lamps shall be factory installed and wired to a SPDT disconnect switch and door interlock switches in each door. Fixtures are wired for 120 v/single ph requiring a minimum circuit ampacity of 15 amps. Lamps shall ship separately for field installation to minimize the chance for bulb damage.

D. Emitters and fixtures shall be installed in sufficient quantity and arranged so as to provide an equal distribution of UV-C energy on the coil and drain pan.

E. The minimum UV-C energy striking the leading edge of the coil pan shall be not less than 820 μW/cm<sup>2</sup> at the closest point and through placement, not less than 60% of that value at the farthest point. Equal amounts are to strike the drain pan, either directly or indirectly through reflection.

F. Emitters and fixtures shall be installed such that UV-C energy strikes all surfaces of the coil, drain pan, and the available line of sight airstream.

## 2.13 ELECTRICAL ACCESSORIES:

### A. Marine Lights and Convenience Outlets:

1. Cast, non-ferrous metal, weatherproof, fixture.
2. Cast, non-ferrous metal, weatherproof, electrical junction box.
3. Gasketed, heat and shock resistant glass globe protects against moisture and debris.
4. Cast, non-ferrous metal lamp guard to protect glass globe.
5. UL and CSA listed.
6. 100 watt type 'A' lamp maximum capacity.

7. Each fixture is equipped with a 9.5 watt, 120 volt 800 lumen LED lamp with an average rated life of 25,000 hours, factory installed.
8. Metallic, single gang, electrical junction box, UL listed.
9. With convenience outlet: Factory supplied and wired, SPST, toggle switch and 15 amp, 120 vac/60 Hz, NEMA 5-15 type, ground fault circuit interrupt (GFCI) receptacle, UL listed.
10. Without convenience outlet: Factory supplied and wired, SPST, UL listed toggle switch.
11. Each fixture is factory wired to an externally mounted switch box. (Field power connections are made to the switch box mounted externally on the unit.)
12. All factory wiring penetrating through the panel is protected in 'RIGID' type metal conduit.

**B. Disconnects:**

Factory-supplied disconnects shall be covered under a 1 year limited warranty from the manufacturer from the date of shipment.

1. 115-230 volt/single-phase non-fused disconnects shall have the following characteristics:
  - a. Plated current carrying components for superior corrosion protection.
  - b. Factory-installed equipment grounding terminals with slot/square drive screws.
  - c. Rated for motor disconnect applications (10 Hp maximum).
  - d. NEMA type 3R non-metallic enclosure.
  - e. Up to 10,000 rms symmetrical amperes SCCR, when protected by a fuse or circuit breaker rated 60 amperes or less.
  - f. Cover padlock hasp.
  - g. Pull-out cartridge type.
  - h. UL listed.
2. 115-230 volt/single-phase fused disconnects shall have the following characteristics:
  - a. Visible blades.
  - b. Quick-make, quick-break operating mechanism.
  - c. Cover padlock hasp and handle lock "OFF."
  - d. 240 vac maximum.
  - e. Factory supplied and installed class 'T Series' fuses (fused disconnects only).
  - f. Up to 10,000 rms symmetrical amperes SCCR, utilizing appropriately rated factory-supplied fuses.
  - g. Horsepower rated for motor applications.
  - h. Tangential combination knockouts for field wiring.
  - i. Spring reinforced plated copper fuse clips.
  - j. NEMA type 1 enclosures.
  - k. Insulated, bondable solid neutral assemblies.
  - l. UL listed, File E2875.

- m. Meet or exceed NEMA KS1-1990.
3. 200-230 volt/3-phase fused and non-fused disconnects shall have the following characteristics:
  - a. Visible blades.
  - b. Quick-make, quick-break operating mechanism.
  - c. Cover padlock hasp and handle lock "OFF."
  - d. 240 vac maximum.
  - e. Factory supplied and installed class RK5 fuses (fused disconnects only).
  - f. Up to 100,000 rms symmetrical amperes SCCR, utilizing appropriately rated, factory-supplied Class R fuses.
  - g. Horsepower rated for motor applications.
  - h. Tangential combination knockouts for field wiring.
  - i. Spring reinforced plated copper fuse clips.
  - j. NEMA type 1 enclosures.
  - k. Insulated, bondable solid neutral assemblies.
  - l. UL listed, File E2875.
  - m. Meet or exceed NEMA KS1-1990.

4. 380-575 volt/3-phase fused and non-fused disconnects shall have the following characteristics:
  - a. Visible switch blades with for positive "OFF" indication.
  - b. Quick-make, quick-break operating mechanism.
  - c. Dual cover interlock.
  - d. Color coded "ON" — "OFF" indicator handle.
  - e. Cover padlock hasp and handle lock "OFF" provision for multiple padlocks.
  - f. 600 vac maximum.
  - g. Factory supplied and installed class RK5 fuses (fused disconnects only).
  - h. Up to 200,000 rms symmetrical amperes SCCR, utilizing appropriately rated, factory-supplied Class R fuses.
  - i. Horsepower rated for motor applications.
  - j. Spring reinforced plated copper fuse clips.
  - k. Tangential combination knockouts.
  - l. NEMA type 1 enclosures.
  - m. Insulated, bondable solid neutral assemblies.
  - n. Wire terminations suitable for aluminum or copper conductors.
  - o. UL listed.
  - p. Meet or exceed NEMA KS1-1999.

**C. Starters:**

Factory-supplied disconnects shall be covered under a 1 year limited warranty from the manufacturer from the date of shipment.

1. Starter without disconnect:
  - a. Adjustable motor overload with trip indication.
  - b. Manual overload reset button (accessible without opening enclosure).

# Guide specifications — indoor unit (cont)



- c. 115-v fused secondary control transformer (fuse included — fused primary and secondary over 50 amps).
  - d. Hand/Off/Auto selector switch (accessible without opening enclosure).
  - e. Separate 4-position terminal strip for remote H-O-A wiring.
  - f. C series contactors.
  - g. Horsepower rated for motor applications.
  - h. NEMA 4X type non-metallic enclosures.
  - i. Lug connections for field wiring.
  - j. Factory mounted, wired, and run tested with factory-supplied motor.
  - k. UL listed.
2. Combination Starter/Disconnect:
- a. Non-fused UL 508 disconnect switch with lockable handle (locks not provided).
  - b. Cover interlock.
  - c. Adjustable motor overload with trip indication.
  - d. Manual overload reset button (accessible without opening enclosure).
  - e. 115-v fused secondary control transformer (fuse included — fused primary and secondary over 50 amps).
  - f. Hand/Off/Auto selector switch (accessible without opening enclosure).
  - g. Separate 4-position terminal strip for remote H-O-A wiring.
  - h. C series contactors.
  - i. Horsepower rated for motor applications.
  - j. NEMA 4X type non-metallic enclosures.
  - k. Lug connections for field power wiring.
  - l. Factory mounted, wired, and run tested with factory-supplied motor.
  - m. UL listed.

## D. Bypass for Variable Frequency Drives:

Factory-supplied bypasses shall be covered under a 1 year limited warranty from the manufacturer from the date of shipment.

- 1. 200-230 v/3 Ph/60 Hz (1 to 7.5 Hp), 460-575 v/3 Ph/60 Hz (1 to 20 Hp), 380 v/3 Ph/50 Hz (1 to 15 Hp):
  - a. 4-position panel-mounted disconnect style switch with lockable handle (locks not provided), meets OSHA 1910.
  - b. Switch position indication (LINE/OFF/DRIVE/TEST).
  - c. Adjustable motor overload with trip indication (LINE position).
  - d. Manual overload reset button.
  - e. Horsepower rated for motor applications.
  - f. Direct control (no contactors, relays, or holding coils).

- g. Complete isolation of inverter in LINE position.
  - h. NEMA 12 type metal enclosures.
  - i. Terminal strip provided for field power supply wiring.
  - j. Lug connection for field ground wire.
  - k. Gold flashed, auxiliary switch contact set (for switch position monitoring).
  - l. Factory mounted, wired to VFD and motor, and run tested (motor and VFD must be factory supplied and installed).
  - m. UL; UL, Canada; CE listed.
2. 200-230 v/3 Ph/60 Hz (10 to 75 Hp), 460-575 v/3 Ph/60 Hz (25 to 150 Hp), 380 v/3 Ph/50 Hz (20 to 75 Hp):
- a. 4-position panel-mounted disconnect style switch with lockable handle (locks not provided), meets OSHA 1910.
  - b. Switch position indication (LINE/OFF/DRIVE/TEST).
  - c. Adjustable motor overload with trip indication (in LINE position).
  - d. Manual overload reset button.
  - e. Horsepower rated for motor applications.
  - f. 115-v control transformer with fused secondary (fused primary on units over 50 amps).
  - g. Contactor for Line Start/Stop.
  - h. Door-mounted Line Start and Line Stop pushbuttons.
  - i. Complete isolation of inverter in LINE position.
  - j. NEMA 12 type metal enclosures.
  - k. Terminal strip provided for field power supply wiring.
  - l. Lug connection for field ground wire.
  - m. Gold flashed, auxiliary switch contact set (for switch position monitoring).
  - n. Factory mounted, wired to VFD and motor, and run tested (motor and VFD must be factory supplied and installed).
  - o. UL; UL, Canada; CE listed.

## E. Variable Frequency Drives:

- 1. Factory-mounted variable frequency drives (VFDs) shall be wired to factory-supplied motors.
- 2. Factory-supplied VFDs are programmed and started up from the factory and qualify the VFD, through ABB, for a 24-month warranty from date of commissioning or 30 months from date of sale, whichever occurs first.
- 3. The VFD parameters are programmed into the controller and removable keypad. In the event that the VFD fails and needs replacement, the



- program can then be uploaded to the replacement VFD via the original keypad.
4. The VFD package as specified herein shall be enclosed in a UL Listed type enclosure, exceeding NEMA enclosure design criteria (enclosures with only NEMA ratings are not acceptable), completely assembled and tested by the manufacturer in an ISO 9001 facility. The VFD tolerated voltage window shall allow the VFD to operate from a line of +30% nominal, and -35% nominal voltage as a minimum.
    - a. Environmental operating conditions: VFDs shall be capable of continuous operation at -15 to 40 C (5 to 104 F) ambient temperature with no frost allowed as per VFD manufacturers documented/submittal data or VFD must be oversized to meet these temperature requirements. Not acceptable are VFDs that can only operate at 40 C intermittently (average during a 24-hour period) and therefore, must be oversized. VFDs shall be capable of operating at altitude 0 to 3300 ft above sea level and less than 95% humidity, non-condensing. All circuit boards shall have conformal coating.
    - b. Enclosure shall be rated UL Type 1 and shall be UL listed as a plenum rated VFD. VFDs without these ratings are not acceptable. Type 1 enclosures with only NEMA rating are not acceptable (must be UL Type 1).
  5. All VFDs shall have the following standard features:
    - a. All VFDs shall have the same customer interface, including digital display, and keypad, regardless of horsepower rating. The keypad shall be removable, capable of remote mounting and allow for uploading and downloading of parameter settings as an aid for start-up of multiple VFDs.
    - b. The keypad shall include Hand-Off-Auto selections and manual speed control. The drive shall incorporate “bumpless transfer” of speed reference when switching between “Hand” and “Auto” modes. There shall be fault reset and “Help” buttons on the keypad. The Help button shall include “on-line” assistance for programming and troubleshooting.
    - c. There shall be a built-in timeclock in the VFD keypad. The clock shall have a battery back-up with 10 years minimum life span. The clock shall be used to date and time stamp faults and record operating parameters at the time of fault. If the battery fails, the VFD shall automatically revert to hours of operation since initial power up. Capacitor back-up is not acceptable. The clock shall also be programmable to control start/stop functions, constant speeds, PID parameter sets and output Form-C relays. The VFD shall have a digital input that allows an override to the timeclock (when in the off mode) for a programmable time frame. There shall be four (4) separate, independent timer functions that have both weekday and weekend settings.
    - d. The VFDs shall utilize pre-programmed application macros specifically designed to facilitate start-up. The application macros shall provide one command to reprogram all parameters and customer interfaces for a particular application to reduce programming time. The VFD shall have two user macros to allow the end-user to create and save custom settings.
    - e. The VFD shall have cooling fans that are designed for easy replacement. The fans shall be designed for replacement without requiring removing the VFD from the wall or removal of circuit boards. The VFD cooling fans shall operate only when required. To extend the fan and bearing operating life, the VFD shall cycle the cooling fans on and off as required.
    - f. The VFD shall be capable of starting into a coasting load (forward or reverse) up to full speed and accelerate or decelerate to set point without tripping or component damage (flying start).
    - g. The VFD shall have the ability to automatically restart after an overcurrent, over-voltage, under-voltage, or loss of input signal protective trip. The number of restart attempts, trial time, and time between attempts shall be programmable.
    - h. The overload rating of the drive shall be 110% of its normal duty current rating for 1 minute every 10 minutes, 130% overload for 2 seconds. The minimum FLA rating shall meet or exceed the values in the NEC/UL table 430.250 for 4-pole motors.
    - i. The VFD shall have internal 5% impedance reactors to reduce the harmonics to the power line and to add protection from AC line transients. The 5% impedance may be from dual (positive and negative DC bus) reactors, or 5% AC line reactors. VFDs with only one DC reactor shall add an AC line reactor.
    - j. The input current rating of the VFD shall be no more than 3% greater than the output current rating. VFDs with higher input current ratings require the upstream wiring, protection devices, and source transformers to be oversized per NEC 430.120. Input and output current ratings must be shown on the VFD nameplate.
    - k. The VFD shall include a coordinated AC transient surge protection system consisting

of 4 to 120 joule rated MOVs (phase to phase and phase to ground), a capacitor clamp, and 5% impedance reactors.

1. The VFD shall provide a programmable loss-of-load (broken belt/broken coupling) Form-C relay output. The drive shall be programmable to signal the loss-of-load condition via a keypad warning, Form-C relay output, and/or over the serial communications bus. The loss-of-load condition sensing algorithm shall include a programmable time delay that will allow for motor acceleration from zero speed without signaling a false loss-of-load condition.
  - m. The VFD shall have user programmable underload and overload curve functions to allow user defined indications of broken belt or mechanical failure/jam condition causing motor overload
  - n. The VFD shall include multiple “two zone” PID algorithms that allow the VFD to maintain PID control from two separate feedback signals (4 to 20mA, 0 to 10V, and/or serial communications). The two zone control PID algorithm will control motor speed based on a minimum, maximum, or average of the two feedback signals. All of the VFD PID controllers shall include the ability for “two zone” control.
  - o. If the input reference (4 to 20mA or 2 to 10V) is lost, the VFD shall give the user the option of either (1) stopping and displaying a fault, (2) running at a programmable preset speed, (3) hold the VFD speed based on the last good reference received, or (4) cause a warning to be issued, as selected by the user. The drive shall be programmable to signal this condition via a keypad warning, Form-C relay output and/or over the serial communication bus.
  - p. The VFD shall have programmable “Sleep” and “Wake up” functions to allow the drive to be started and stopped from the level of a process feedback signal.
6. All VFDs to have the following adjustments:
- a. Three (3) programmable critical frequency lockout ranges to prevent the VFD from operating the load continuously at an unstable speed. The lockout range must be fully adjustable, from 0 to full speed.
  - b. Two (2) PID set point controllers shall be standard in the drive, allowing pressure or flow signals to be connected to the VFD, using the microprocessor in the VFD for the closed-loop control. The VFD shall have 250 mA of 24 VDC auxiliary power and be capable of loop powering a transmitter supplied by others. The PID set point shall be adjustable from the VFD keypad, analog inputs, or over the communications bus. There shall be two independent parameter sets for the PID controller and the capability to switch between the parameter sets via a digital input, serial communications or from the keypad. The independent parameter sets are typically used for night setback, switching between summer and winter set points, etc.
  - c. There shall be an independent, second PID loop that can utilize the second analog input and modulate one of the analog outputs to maintain the set point of an independent process (i.e. valves, dampers, etc.). All set points, process variables, etc. to be accessible from the serial communication network.
  - d. Two (2) programmable analog inputs shall accept current or voltage signals.
  - e. Two (2) programmable analog outputs (0 to 20 mA or 4 to 20 mA). The outputs may be programmed to output proportional to Frequency, Motor Speed, Output Voltage, Output Current, Motor Torque, Motor Power (kW), DC Bus voltage, Active Reference, Active Feedback, and other data.
  - f. Six (6) programmable digital inputs for maximum flexibility in interfacing with external devices. All digital inputs shall be programmable to initiate upon an application or removal of 24 VDC or 24 VAC.
  - g. Three (3) programmable, digital Form-C relay outputs. The relay outputs shall include programmable on and off delay times and adjustable hysteresis. The relays shall be rated for maximum switching current 8 amps at 24 VDC and 0.4 A at 250 VAC; Maximum voltage 300 VDC and 250 VAC; continuous current rating of 2 amps RMS. Outputs shall be true Form-C type contacts; open collector outputs are not acceptable.
  - h. Run permissive circuit: There shall be a run permissive circuit for damper or valve control. Regardless of the source of a run command (keypad, input contact closure, time-clock control, or serial communications), the VFD shall provide a dry contact closure that will signal the damper to open (VFD motor does not operate). When the damper is fully open, a normally open dry contact (end-switch) shall close. The closed end-switch is wired to a VFD digital input and allows VFD motor operation. Two separate safety interlock inputs shall be provided. When either safety is opened, the motor shall be commanded to coast to stop and the damper shall be commanded to close. The keypad shall display “start enable 1 (or 2) missing”. The safety input status shall also be transmitted over the serial communications bus.

- i. The VFD control shall include a programmable time delay for VFD start and a keypad indication that this time delay is active. A Form C relay output provides a contact closure to signal the VAV boxes open. This will allow VAV boxes to be driven open before the motor operates. The time delay shall be field programmable from 0 to 120 seconds. Start delay shall be active regardless of the start command source (keypad command, input contact closure, time-clock control, or serial communications).
  - j. Seven (7) programmable preset speeds.
  - k. Two independently adjustable accelerate and decelerate ramps with 1 to 1800 seconds adjustable time ramps.
  - l. The VFD shall include a motor flux optimization circuit that will automatically reduce applied motor voltage to the motor to optimize energy consumption and reduce audible motor noise. The VFD shall have selectable software for optimization of motor noise, energy consumption, and motor speed control.
  - m. The VFD shall include a carrier frequency control circuit that reduces the carrier frequency based on actual VFD temperature that allows higher carrier frequency settings without derating the VFD.
  - n. The VFD shall include password protection against parameter changes.
7. The keypad shall include a backlit LCD display. The display shall be in complete English words for programming and fault diagnostics (alpha-numeric codes are not acceptable). All VFD faults shall be displayed in English words. The keypad shall include a minimum of 14 assistants including:
- a. Start-up assistant
  - b. Parameter assistants
  - c. PID assistant
  - d. Reference assistant
  - e. I/O assistant
  - f. Serial communications assistant
  - g. Option module assistant
  - h. Panel display assistant
  - i. Low noise set-up assistant
  - j. Maintenance assistant
  - k. Troubleshooting assistant
  - l. Drive optimizer assistants
8. All applicable operating values shall be capable of being displayed in engineering (user) units. A minimum of three operating values from the list below shall be capable of being displayed at all times. The display shall be in complete English words (alpha-numeric codes are not acceptable):
- a. Output Frequency
  - b. Motor Speed (RPM, %, or Engineering units)
  - c. Motor Current
  - d. Motor Torque
  - e. Motor Power (kW)
  - f. DC Bus Voltage
  - g. Output Voltage
9. The VFD shall include a fireman's override input. Upon receipt of a contact closure from the fire / smoke control station, the VFD shall operate in one of two modes: 1) Operate at a programmed predetermined fixed speed ranging from -500 Hz (reverse) to 500 Hz (forward). 2) Operate in a specific fireman's override PID algorithm that automatically adjusts motor speed based on override set point and feedback. The mode shall override all other inputs (analog/digital, serial communication, and all keypad commands), except customer defined safety run interlocks, and force the motor to run in one of the two modes above. "Override Mode" shall be displayed on the keypad. Upon removal of the override signal, the VFD shall resume normal operation, without the need to cycle the normal digital input run command.
10. Serial Communications:
- a. The VFD shall have an EIA-485 port as standard. The standard protocols shall be Modbus, Johnson Controls N2, Siemens Building Technologies FLN, and BACnet\*. [Optional protocols for LonWorks†, Profibus, EtherNet, BACnet IP, and DeviceNet shall be available.] Each individual drive shall have the protocol in the base VFD. The use of third party gateways and multiplexers is not acceptable. All protocols shall be "certified" by the governing authority (i.e., BTL Listing for BACnet). Use of non-certified protocols is not allowed.
  - b. The BACnet connection shall be an EIA-485, MS/TP interface operating at 9.6, 19.2, 38.4, or 76.8 Kbps. The connection shall be tested by the BACnet Testing Labs (BTL) and be BTL Listed. The BACnet interface shall conform to the BACnet standard device type of an Applications Specific Controller (B-ASC). The interface shall support all BIBBs defined by the BACnet standard profile for a B-ASC including, but not limited to:
    - 1) Data Sharing – Read Property – B.
    - 2) Data Sharing – Write Property – B.
    - 3) Device Management – Dynamic Device Binding (Who-Is; I-Am).

- 4) Device Management – Dynamic Object Binding (Who-Has; I-Have).
  - 5) Device Management – Communication Control – B.
  - c. If additional hardware is required to obtain the BACnet interface, the VFD manufacturer shall supply one BACnet gateway per drive. Multiple VFDs sharing one gateway shall not be acceptable.
  - d. Serial communication capabilities shall include, but not be limited to; run-stop control, speed set adjustment, proportional/integral/derivative PID control adjustments, current limit, accel/decel time adjustments, and lock and unlock the keypad. The drive shall have the capability of allowing the DDC to monitor feedback such as process variable feedback, output speed / frequency, current (in amps), % torque, power (kW), kilowatt hours (resettable), operating hours (resettable), and drive temperature. The DDC shall also be capable of monitoring the VFD relay output status, digital input status, and all analog input and analog output values. All diagnostic warning and fault information shall be transmitted over the serial communications bus. Remote VFD fault reset shall be possible.
  - e. The VFD shall include an independent PID loop for customer use. The independent PID loop may be used for cooling tower bypass valve control, chilled water valve / hot water valve control, etc. Both the VFD PID control loop and the independent PID control loop shall continue functioning even if the serial communications connection is lost. As default, the VFD shall keep the last good set point command and last good DO and AO commands in memory in the event the serial communications connection is lost and continue controlling the process.
11. EMI/RFI filters: All VFDs shall include EMI/RFI filters. The onboard filters shall allow the VFD assembly to be CE Marked and the VFD shall meet product standard EN 61800-3 for the First Environment restricted level with up to 100 feet of motor cable. No Exceptions. Certified test reports shall be provided with the submittals confirming compliance to EN 61800-3, First Environment.
  12. All VFDs through 75 hp at 480 V shall be protected from input and output power mis-wiring. The VFD shall sense this condition and display an alarm on the keypad. The VFD shall not sustain damage from this power mis-wiring condition.
  13. Operational Functions:
    - a. The drive shall contain two separate acceleration/deceleration times with auto tuning for optimum setting (0.1 to 6000 seconds) with choice of linear, S, or C curves that shall be factory programmed to match the fan load and prevent nuisance overcurrent fault trips.
  - b. The drive shall be equipped with both local/remote and manual/auto keys on touchpad.
  - c. The drive shall be equipped with a quick setup key.
  - d. The drive shall contain 15 preset speeds, which can be activated from the keypad, terminal inputs, and host computer.
  - e. The drive shall have the capability of storable special custom user setting.
  - f. The drive shall restart into a rotating motor operating in either the forward or reverse direction and match that frequency.
  - g. The drive shall have adjustable soft stall (10% to 150%) which reduces frequency and voltage of the inverter to sustain a run in an overload situation factory programmed for each motor's characteristics.
  - h. The drive shall be capable of performing a time base pattern run using 4 groups of 8 patterns each using the 15 preset speed values for a maximum of 32 different patterns.
  - i. The drive shall have adjustable UL listed electronic overload protection (10% to 100%) factory programmed to match each motor's FLA/RLA (full load amp/rated load amp) ratings.
  - j. The drive shall have a custom programmable volt/hertz pattern.
14. Protective Features:
    - a. The drive shall be rated for 200,000 AIC (ampere interrupting capacity). The use of input fuses to achieve this rating shall not be acceptable.
    - b. The drive shall have external fault input.
    - c. The drive shall be capable of resetting faults remotely and locally.
    - d. The drive shall be programmable to alert the following alarms:
      - 1) Over torque alarm.
      - 2) Inverter overload pre-alarm.
      - 3) Motor overload pre-alarm.
      - 4) Braking resistor overload pre-alarm.
      - 5) Inverter overheat pre-alarm.
      - 6) Undercurrent alarm.
      - 7) Overcurrent pre-alarm.
      - 8) Communication error alarm.
      - 9) Cumulative timer alarm.
      - 10) Executing retry.
    - e. The drive shall identify and display the following faults:
      - 1) Overcurrent during acceleration trip.

- 2) Overcurrent during deceleration trip.
  - 3) Overcurrent during normal run trip.
  - 4) Overcurrent on the DC Bus during acceleration trip.
  - 5) Overcurrent on the DC Bus during deceleration trip.
  - 6) Overcurrent on the DC Bus during normal run trip.
  - 7) Load end overcurrent trip detected at start-up (output terminals, motor wiring, etc.).
  - 8) U-phase short circuit trip detected at start-up.
  - 9) V-phase short circuit trip detected at start-up.
  - 10) W-phase short circuit trip detected at start-up.
  - 11) Overvoltage during acceleration trip.
  - 12) Overvoltage during deceleration trip.
  - 13) Overvoltage during normal (constant speed) run trip.
  - 14) Inverter overloaded trip.
  - 15) Motor overloaded trip.
  - 16) Inverter overheat trip.
  - 17) Emergency off trip message.
  - 18) EEPROM failure during write cycle.
  - 19) EEPROM abnormality during initial reading.
  - 20) RAM error.
  - 21) ROM error.
  - 22) CPU error.
  - 23) Communication interruption error.
  - 24) Gate array error.
  - 25) Output current detection circuit error.
  - 26) Option PCB error trip.
  - 27) Low operating current trip.
  - 28) Main circuit under voltage trip.
  - 29) Over torque trip.
  - 30) Software detected earth fault trip.
  - 31) Hardware detected earth fault trip.
  - 32) Inverter type form mismatch error.
  - 33) EEPROM type form mismatch error.
15. Monitor Functions:
- a. The drive digital display shall be capable of displaying the following: Frequency, percent current, current amps, percent voltage I/O, voltage in volts I/O, RPM, GPM, I/O watts, torque, and input reference signal, kWh.
  - b. The drive shall have 320 programmable parameters which can be changed while the drive is operating.
  - c. The drive's 353 parameters shall be adjustable from the 8-key touchpad or computer link.
  - d. The drive's 8-key touchpad shall be NEMA 12 rated.
  - e. The drive's keypad shall be capable of being extended 15 ft from the drive.
  - f. The drive shall contain a reset of all parameters to factory default settings or user defaults (whichever one is chosen).
  - g. The drive shall have 2 programmable analog outputs programmable to 17 choices.
  - h. The drive shall have one programmable relay output programmable to 67 choices.
  - i. The drive shall have 8 programmable digital inputs programmable to 54 choices.
  - j. The drive shall have a pulse train out-put proportional to frequency (48, 96, 360 times frequency).
  - k. The drive shall have an elapsed time meter.
16. Options:
- a. VFD with Integral Disconnect:
    - 1) UL listed by the drive manufacturer as a complete assembly.
    - 2) UL 508 labeled .
    - 3) Capable of being locked by three padlocks.

## 39MW Weathertight Outdoor Air Handlers

### HVAC Guide Specifications

Size Range: **1,500 to 60,500 Nominal Cfm**

Carrier Model Number: **39MW — Outdoor Unit**

#### Part 1 — General

##### 1.01 QUALITY ASSURANCE

###### A. Manufacturer Qualifications:

Company specializing in manufacturing the products specified in this section with minimum of 5 years documented experience.

###### B. Units shall be manufactured in a facility registered to ISO (International Organization for Standardization) 9001 manufacturing quality standard.

###### C. Air-handling unit assembly shall have UL (Underwriters Laboratories) 1995 certification for safety, including use with electric heat.

###### D. Products requiring electric connection shall be listed and classified by ETL and CSA (Canadian Standards Association) as suitable for the purpose specified and indicated.

###### E. Coil performance shall be certified in accordance with AHRI (Air-Conditioning, Heating, and Refrigerating Institute) Standard 410, latest edition.

###### F. Unit performance shall be rated in accordance with AHRI Standard 430 for Central Air-Handling Units and subject to verification of rating accuracy by AHRI-sponsored, third party testing. Units shall meet NFPA (National Fire Protection Association) 90A requirements.

##### 1.02 DELIVERY, STORAGE AND PROTECTION

###### A. All outdoor units shall be completely shrink-wrapped from the factory for protection during shipment. Tarping of bare units is unacceptable.

###### B. Inspect for transportation damage and store in clean dry place and protect from weather and construction traffic. Handle carefully to avoid damage to components, enclosures, and finish.

##### 1.03 START-UP REQUIREMENTS

Do not operate units until ductwork is clean, filters are in place, bearings lubricated, condensate properly trapped, piping connections verified and leak tested, belts aligned and tensioned, all shipping braces have been removed, and fan has been test run under observation.

#### Part 2 — Products

##### 2.01 GENERAL DESCRIPTION

###### A. Units shall ship in the number of sections necessary to meet project requirements and shall ship in as many splits as specified in selection software. Split options as follows:

1. Shipped in sections — shipping split.
2. Shipped assembled — base rail break (shipped attached).
3. Shipped assembled — solid base rail.

###### B. Unit shall be factory-supplied, factory-assembled, outdoor, curb-mounted central station air handler. The air-handling unit may consist of a fan with the following factory-installed components as indicated on the equipment schedule.

###### 1. Mixing Box Section:

- a. No filter tracks.
- b. With filter tracks.
- c. With angle filter tracks
- d. With bag cartridge filter tracks.
- e. With exhaust air dampers.

###### 2. Air Mixer Section.

###### 3. Exhaust Box Section.

###### 4. Integral Face and Bypass Section:

- a. With hot water coil.
- b. With steam coil.

###### 5. Internal Face and Bypass Damper Section.

###### 6. Plenum Section:

- a. With drain pan.
- b. No drain pan.

###### 7. Humidifier Section.

###### 8. Blow-Thru Discharge Plenum.

###### 9. Filter Section:

- a. 2-in. flat filters.
- b. 4-in. flat filters.
- c. 4-in. flat filters with 2-in. pre-filters.
- d. 2-in. angle filters.
- e. 4-in. angle filters.
- f. Side loading 12-in. bag/cartridge filters with 2-in. pre-filters.
- g. Side loading 30-in. bag/cartridge filters with 2-in. pre-filters.
- h. Face loading bag/cartridge filters without pre-filters. Maximum bag/cartridge filter length is limited to access/plenum sections placed after this section.
- i. Face loading HEPA (high-efficiency particulate air) bag/cartridge filters without pre-filters.

###### 10. Coil Section:

- a. Chilled water coil.
- b. Direct expansion coil.
- c. Hot water coil.
- d. Steam coil.
- e. Electric coil

###### 11. Gas Heating Section.

###### 12. Fan Section:

- a. Horizontal draw-thru.
- b. Horizontal blow-thru (with integral diffuser).
- c. Plenum fan (with optional exhaust air damper on return fan only).

## 2.02 CASING

### A. Construction:

1. Unit shall be constructed of a complete frame with easily removable panels. Removal of any panel shall not affect the structural integrity of the unit.
2. All units shall be supplied with a perimeter, 14-gage or heavier, G-90 galvanized, high tensile steel base rail with a pocket to accommodate roof curb. Perimeter lifting lugs for overhead lifting shall be provided on each shipping section. Slings units in place of lifting lugs shall not be acceptable.
3. Unit shall be thermally broken to minimize the conduction path from the inside of the casing to the outside.
4. Casing panels (top, sides, and bottom) shall be constructed of galvanized steel, and shall have one of the following exterior finishes as specified:
  - a. Pre-painted with a baked enamel finish passing 500-hour salt spray test (ASTM [American Society of Mechanical Engineers] B-117) for pre-painted steel and 125-hour marine level 1 prohesion test (ASTM G-85.A5) for pre-painted steel.
  - b. Unpainted G-90 galvanized steel.
5. Casing panels (top, sides, and bottom) shall be constructed of galvanized or stainless steel, and shall have one of the following interior finishes as specified:
  - a. Pre-coated galvanized steel with a silver zeolite antimicrobial material registered by the US EPA (Environmental Protection Agency) for use in HVAC applications.
  - b. Unpainted G-90 galvanized steel.
  - c. Unpainted 304 stainless steel.
6. Roof shall be double-wall, pitched in four directions at a minimum roof slope of  $1/4$ -in. per foot across the width of the unit. No penetrations shall be made in pressure sensitive panels. Roof shall incorporate a standing top seam. All seams in the roof shall be gasketed and capped to prevent water infiltration into the unit.
7. Casing panels (top, sides, and bottom) shall be one piece double-wall construction with insulation sealed between the inner and outer panels. Panel assemblies shall not carry an R-value of less than 13.
8. Casing deflection shall not exceed an L/240 ratio when subject to an internal pressure of  $\pm 8$ -in. wg and shall exhibit no permanent deformation at  $\pm 9$  in. wg L is defined as the longest linear panel or cabinet length (measured at AHRI 1350 Cd level 2).
9. Casing leakage rate shall be less than 1% at  $\pm 8$  in. wg of nominal unit airflow or 50 cfm, which-

ever is greater. Leakage rate shall be tested and documented on a routine basis on random production units. Optionally, factory witness leak testing and/or test reports shall be available.

10. Side panels shall be easily removable for access to unit and shall seal against a full perimeter automotive style gasket to ensure a tight seal.
11. The panel retention system shall comply with UL 1995 which states all moving parts (for example, fan blades, blower wheels, pulleys, and belts) that, if accidentally contacted, could cause bodily injury, shall be guarded against accidental contact by an enclosure requiring tools for removal.
12. Base rail shall overhang the curb to facilitate water run-off and protection of the curb to base connection from water intrusion.
13. Accessibility options shall be as follows:
  - a. Hinged double-wall access door on either side with removable access panel(s) on the other side.
  - b. Hinged double-wall access doors on both sides.
  - c. Removable double-wall access panels on both sides.
14. Depending on the options selected and the remaining available space inside each section, the following options may be available:
  - a. Thermal pane reinforced glass viewports shall be factory-installed on the access panel(s) or door(s) of this section.
  - b. Marine lights shall be factory-installed with or without GCFI (ground fault circuit interrupter) convenience outlets.
15. Fan supports, structural members, panels, or flooring shall not be welded, unless aluminum, stainless steel, or other corrosion-resistant material is used. Painted welds on unit exterior steel or galvanized steel are not acceptable.
16. All coil sections shall be solid double-wall construction with insulation sealed between the inner and outer panels. Panel assemblies shall not carry an R-value of less than 13.
17. Blow-thru fan sections shall have a diffuser plate as an integral part of the fan section.

### B. Access Doors:

Access doors shall be one piece double-wall construction with insulation sealed between the inner and outer panels. Panel assemblies shall not carry an R-value of less than 13.

### C. Drain Pans:

Drain pans shall be insulated double-wall galvanized or stainless steel construction. The pan shall be sloped toward the drain connection. Drain pan shall have  $1\frac{1}{2}$ -in. MPT connection exiting through the hand side or opposite side of the casing as specified. Drain connection shall be insulated from the drain

pan to the point at which it exits the casing. One drain outlet shall be supplied for each cooling coil section. Drain pan shall allow no standing water and comply with ASHRAE (American Society of Heating, Refrigerating, and Air-Conditioning Engineers) Standard 62.1-2010. Where 2 or more coils are stacked in a coil bank, intermediate drain pans shall be provided and the condensate shall be piped to the bottom drain pan. The bottom coil shall not serve as a drain path for the upper coil.

#### D. Roof Curbs:

1. Roof curb shall be delivered to jobsite in an unassembled, knockdown state.
2. Curb shall be constructed of 14-gage G-90 galvanized steel, 14 in. or 24 inches in height.
3. Full perimeter wood nailers shall be securely mounted to curb sheet metal.
4. Curb channel supports will be supplied on all curbs exceeding 10 ft in total unit airway length.
5. Gasketing between curb and unit shall be shipped for field installation with the unit curb.
6. Coil connection housing curb will be offered optionally to enclose coil piping. Multiple coil connection housings may be specified (up to two per side).

#### E. Hoods and Louvers:

1. Outside Air Hoods:
  - a. Outside air hoods shall be constructed of 20-gage galvanized G-90 steel and sized for 100% of unit nominal cfm.
  - b. Hoods shall include easily accessible 1-in. moisture eliminators with a maximum velocity of no more than 500 fpm.
2. Exhaust Air Hoods:
  - a. Exhaust air hoods shall be constructed of 16-gage galvanized G-90 steel and shipped collapsed in place.
  - b. Expanded metal bird screen shall be provided to prevent entry of unwanted materials into air handler.
3. Power Exhaust Air Hood:
  - a. Power exhaust air hoods shall be constructed of 18-gage galvanized G-90 pre-painted steel.
  - b. Expanded metal bird screen shall be provided to prevent entry of unwanted materials into air handler.
  - c. Optional backdraft damper blades shall be 6063-T5 extruded aluminum channel with galvanized steel braces and extruded vinyl blade seals. Blades shall be mechanically fastened to axle rods rotating in corrosion-resistant, synthetic bearings. Blades begin to open at 0.12 in. wg and are fully open at 0.2 in. wg.

#### 4. Side Intake Louvers:

- a. Frames and blades shall be 6063 alloy, 0.081 in. thick, mechanically fastened with stainless steel fasteners. Frame depth shall be 6 inches.
- b. Vertical blades shall be designed to collect and drain water to exterior at sill by means of a center rain hook and channels in jambs and mullions.
- c. Louvers shall have 1/2-in. mesh removable aluminum bird screen.
- d. Visible mullions required for louver widths greater than 96 inches.
- e. Provide sill-flashing pans 4 in. high by full depth formed from minimum 0.060 in. thick aluminum.
- f. Louvers shall be designed to withstand a wind load of 25 lb per sq ft.
- g. Water penetration shall be no more than 0.01 oz per sq ft of free area at 1250 fpm per AMCA publication 511. The AMCA test was unable to determine the beginning water penetration for this louver due to the fact that it lies above 1250 fpm through free area.
- h. Louver shall have a mill finish.

#### 2.03 FANS

##### A. General:

1. Forward-curved fan sections shall have one double-width double-inlet (DWDI) fan wheel and scroll. They shall be constructed of galvanized steel with baked enamel. They shall be designed for continuous operation at the maximum rated fan speed and motor horsepower. Fans shall have an AMCA class rating corresponding to the static pressure at which the fan is designed to operate (Class I or II). Completed fan assembly shall be dynamically balanced in accordance with AHRI Guideline G and ANSI S2.19 at design operating speed using contract drive and motor if ordered.
2. Airfoil fan sections shall have one DWDI airfoil fan wheel and scroll. Airfoil blades shall be double thickness design constructed of heavy gage, high strength steel or aluminum continuously welded to the backplate and the spun inlet flange. Entire fan assembly shall be cleaned, primed and painted with alkyd enamel, except for an aluminum fan wheel when supplied. Fans shall have an AMCA class rating corresponding to the static pressure at which the fan is designed to operate (Class I or II). Completed fan assembly shall be dynamically balanced to minimum grade of G 6.3 per ANSI/AMCA 204 at design operating speed using contract drive and motor if ordered.
3. Belt drive plenum fan sections shall have one single-width single-inlet (SWSI) airfoil fan wheel.



- Airfoil blades shall be double thickness design constructed of heavy gage, high strength steel or aluminum continuously welded to the backplate and the spun inlet flange. Entire fan assembly shall be cleaned, primed and painted with alkylid enamel, except for an aluminum fan wheel when supplied. They shall be designed for continuous operation at the maximum rated fan speed and motor horsepower. Fans shall have an AMCA class rating corresponding to the static pressure at which the fan is designed to operate (Class I or II). Completed fan assembly shall be dynamically balanced to minimum grade of G 6.3 per ANSI/AMCA 204 at design operating speed using contract drive and motor if ordered.
4. Direct drive plenum fan sections shall have the option of one, two, four, or six single width single inlet (SWSI) airfoil fan wheel(s). Airfoil blades shall be double thickness design continuously welded to the back plate and the front plate. Fan wheel shall be constructed of aluminum. Airfoil blades shall be aluminum extrusions and shall be top welded to the back plate and front plate of the wheel. Fan wheel shall be dynamically balanced per ISO standard 1940 quality grade G6.3.
  5. Fan assembly vibration shall not exceed 0.248 in. per second when mounted on active isolators. Vibration shall be measured in both vertical and horizontal directions at the specified fan operating speed using specified motor. For testing purposes, accelerometers shall be mounted on the motor near the bearing locations and removed before shipment.
  6. All fan sled components shall provide corrosion protection to pass 100-hour salt spray test per ASTM B-117.
  7. Fan wheels shall be keyed to the shaft and shall be designed for continuous operation at maximum rated fan speed and motor horsepower. Fan wheels and shafts shall be selected with a maximum operating speed 25% below the first critical.
  8. Belt drive fan motor shall be mounted within the fan section casing on slide rails equipped with adjusting screws. Motor shall be premium efficiency, open drip-proof or totally enclosed fan cooled NEMA (National Electrical Manufacturers Association) Design A or B with size and electrical characteristics as shown on the equipment schedule. Motor shall be mounted on a horizontal flat surface and shall not be supported by the fan or its structural members. All three-phase motors shall have a  $\pm 10\%$  voltage utilization range and a 1.15 minimum service factor. Motor shall be compliant with the Energy Independence and Security Act (EISA) of 2007 where applicable. Single-phase motors shall be available up to and including 5 hp.
- B. Performance Ratings:  
Fan performance shall be rated and certified in accordance with AHRI Standard 430.
  - C. Sound Ratings:  
Manufacturer shall submit first through eighth octave sound power for fan discharge and casing radiated sound. Sound ratings shall be tested in accordance with AHRI 260.
  - D. Mounting:  
Fan scroll, wheel, shaft, bearings, drives, and motor shall be mounted on a common base assembly. The base assembly is isolated from the outer casing with factory-installed isolators and vibration absorbent an discharge seal. A canvas style duct connection between fan discharge and cabinet is not acceptable. Units shall use 2-in. deflection spring isolators.
  - E. Fan Accessories:
    1. Forward curved fans:
      - a. Variable frequency drives with or without bypass.
      - b. Magnetic motor starters.
      - c. Motor disconnects.
      - d. Airflow measuring piezo ring.
      - e. Piezo ring transducer.
      - f. Motor shaft grounding ring.
      - g. Belt guards.
      - h. Inlet screen.
    2. Airfoil fans:
      - a. Variable frequency drives with or without bypass.
      - b. Magnetic motor starters.
      - c. Motor disconnects.
      - d. Airflow measuring piezo ring.
      - e. Piezo ring transducer.
      - f. Motor shaft grounding ring.
      - g. Belt guards.
      - h. Inlet screen.
    3. Belt drive plenum fans:
      - a. Variable frequency drives with or without bypass.
      - b. Magnetic motor starters.
      - c. Motor disconnects.
      - d. Airflow measuring piezo ring.
      - e. Piezo ring transducer.
      - f. Motor shaft grounding ring.
      - g. Inlet screen and wheel cage.
    4. Direct Drive Plenum Fans:
      - a. Variable frequency drives.
      - b. Motor protection box for motor current protection with a single VFD driving multiple motors.
      - c. Airflow measuring piezo ring.

- d. Piezo ring transducer.
- e. Motor shaft grounding ring.
- f. Inlet guard.
- g. Blank off plate.
- h. Backdraft Dampers

Optional backdraft damper blades shall be 6063-T5 extruded aluminum channel with galvanized steel braces and extruded vinyl blade seals. Blades shall be mechanically fastened to axle rods rotating in corrosion-resistant synthetic bearings. Blades begin to open at 0.12 in. wg and are fully open at 0.2 in. wg.

#### F. Flexible Connection:

The base assembly is isolated from the outer casing with factory-installed isolators and vibration absorbent fan discharge seal. A canvas style duct connection between fan discharge and cabinet is not acceptable.

## 2.04 BEARINGS AND DRIVES

### A. Bearings:

Self-aligning, grease lubricated, anti-friction with lubrication fittings extended to drive side of fan section. Optional grease fittings extended to the exterior of the casing are available. All bearing life calculations shall be done in accordance with ABMA 9 for ball bearings and ABMA 11 for roller bearings.

1. Size 03 to 110 forward-curved fans: Cartridge type bearings for Class I fans. Heavy-duty pillow block type, self-aligning, regreasable ball or roller type bearings selected for a minimum average life ( $L_{50}$ ) of 200,000 hours or optionally for an ( $L_{50}$ ) of 500,000 hours.
2. Size 03 to 110 airfoil fans: Heavy-duty pillow block type, self-aligning, regreasable ball or roller type bearings selected for a minimum average life ( $L_{50}$ ) of 200,000 hours or optionally for an ( $L_{50}$ ) of 500,000 hours.
3. Size 06 to 110 belt-drive plenum fans: Heavy-duty pillow block type, self-aligning, regreasable roller type bearings selected for a minimum average life ( $L_{50}$ ) of 200,000 hours or optionally for an ( $L_{50}$ ) of 500,000 hours.

### B. Shafts:

Fan shafts shall be solid steel, turned, ground, polished and coated with a rust inhibitor.

### C. V-Belt Drive:

Drive shall be designed for a minimum 1.2 service factor as standard with a 1.5 service factor option and/or a factory-supplied extra set of belts. Drives shall be fixed pitch with optional variable pitch for motors 15 hp and less. All drives shall be factory mounted, with sheaves aligned and belts properly tensioned.

## 2.05 COILS

### A. All water, steam and direct expansion (DX) refrigerant coils shall be provided to meet the scheduled

performance. All coil performance shall be certified in accordance with AHRI Standard 410. All water and direct expansion coils shall be tested at 450 psig air pressure. Direct expansion coils shall be designed and tested in accordance with ANSI/ASHRAE 15 Safety Code for Mechanical Refrigeration (latest edition). Factory-supplied  $1/2$ -in. OD coils shall be covered under the standard product one-year limited warranty. All steam coils, integral face and bypass coils and  $5/8$ -in. OD coils shall be warranted for a period not in excess of 12 months from their shipment from the manufacturer. Coil epoxy coating shall be covered under a 5-year limited warranty from the date of shipment from the manufacturer.

### B. General Fabrication:

1. All water and refrigerant coils shall have minimum  $1/2$ -in. OD copper tubes mechanically expanded into fins to ensure high thermal performance with lower total flow and pumping requirements. Minimum tube wall thickness shall be 0.016 inches. Optional tube wall thickness of 0.025 in. shall be supplied, if specified.
2. Optionally, water coils shall have minimum  $5/8$ -in. OD copper tubes mechanically expanded into fins to ensure high thermal performance with lower total flow and pumping requirements. Minimum tube wall thickness shall be 0.020 inches. Optional tube wall thickness of 0.035 in. shall be supplied, if specified.
3. Aluminum plate fin type with belled collars. Optional copper plate fins shall be supplied, if specified. Fin type shall be sine wave construction.
4. Aluminum-finned coils shall be supplied with die-formed casing and tube sheets of mill galvanized steel or stainless steel as specified. Copper-finned coils shall be supplied with stainless steel casing and tube sheets.

### C. Hydronic Heating and Cooling Coils:

1. Headers shall be constructed of steel with steel MPT connections. Headers shall have drain and vent connections accessible from the exterior of the unit. Optional non-ferrous headers and red brass MPT connections shall be supplied if specified.
2. Configuration: Coils shall be drainable, with non-trapping circuits. Coils will be suitable for a design working pressure of 300 psig at 200 F.

### D. Steam Distribution (Non-Freeze Type) Heating Coils:

1. Headers shall be steel with MPT connections.
2. Inner steam distributing tubes shall be  $5/8$ -in. OD, 0.020 in. wall thickness, located within 1 in. OD, 0.030 in. wall outer condensing tubes. Working pressure shall be 175 psig at 400 F.
3. Inner steam distributing tubes shall be  $3/8$ -in. OD, 0.020 in. wall thickness, located within  $5/8$ -in. OD, 0.035 in. wall outer condensing

tubes. Working pressure shall be 175 psig at 400 F.

**E. Integral Face and Bypass Coils:**

1. Sizes 03-14 shall have horizontal steam or hot water coils with a tubewall thickness of not less than 0.020 inches. Tubes shall be mechanically expanded into die formed collars formed in aluminum plate type fins.
2. Sizes 17-110 shall have vertical steam or hot water coils with a tubewall thickness of not less than 0.035 inches. Fins shall be spiral edge-wound copper. Tubes shall be free-floating for thermal expansion and contraction without the use of offset bends or floating headers.

**F. Refrigerant Coils:**

1. Headers shall be constructed of copper with brazed joints.
2. Standard circuiting selections include:
  - a. Single distributor arrangement for sizes 03-17.
  - b. Row split intertwined, multiple distributor arrangement for sizes 03-110.
  - c. Face split, multiple distributor arrangement for sizes 03-110.
3. Thermal expansion valve, replaceable nozzle, brass refrigerant distributors and seamless copper distribution tubes are factory supplied to ensure uniform flow.
4. Submittals must include a DX coil and condensing unit cross plot to show that the coil and condensing unit capacity match at the rated design conditions.

**G. Electric Heating Section:**

1. The electric heater casing is constructed of galvanized steel. Heater control box access door shall be mounted on the designated hand side of the unit. Element construction as follows:
  - a. Open-wire type, 80% nickel, 20% chromium resistance coils, insulated by Steatite bushings and supported in a galvanized steel frame. Bushings shall be recessed into embossed openings and stacked into supporting brackets, spaced no more than 4-in. centers. Thermal cutouts for overtemperature protection shall be provided to meet UL and NEC requirements. Maximum element heating density shall be 55 watts/sq inch.
    - 1) Contactor control - electric heaters up through 60 kW shall have 3 stages of control, beyond 60 kW shall have 6 stages of control.
    - 2) SCR control - electric heaters up through a maximum of 90 amps are available with full SCR control. The entire heater is modulated to achieve the proportional control based on a 0 to 10 volt DC or 4 to 20 mA control signal.

- 3) Vernier control - the heater has full modulating control of the first circuit of heat, all of which is rated at equal kW increments. There is a minimum of 3 circuits for this type of control. These stage increments are turned on and off by a step controller. As each stage fulfills the demand for heat, the SCR increment is used as a fully modulating filler between stages. This end output is a fully proportional control of the electric heater based on a 0 to 10 volt DC or 4 to 20 mA control signal.

- b. Sheathed type, 80% nickel, 20% chromium resistance coils, suspended in a magnesium oxide insulator fill within a tubular steel sheath/brazed fin assembly. Silicone rubber end seals shall prevent contamination of the interior, and the exterior shall be protected from corrosion by a high temperature aluminum coating. Thermal cutouts for overtemperature protection shall be provided to meet UL and NEC requirements. Maximum element heating density shall be 55 watts/sq inch.

- 1) Contactor control - electric heaters up through 60 kW shall have 3 stages of control, beyond 60 kW shall have 6 stages of control.

2. The manufacturer shall furnish an integral control box containing thermal cutouts, primary control, subcircuit fusing, airflow switch, and fused control transformer.

3. Electric heaters shall be UL listed for zero clearance and shall meet all applicable National Electric Code requirements.

4. Units with electric heat sections shall be listed under UL 1995 Standard for Safety.

**2.06 GAS HEATING SECTION**

- A. Indirect fired gas furnace section(s) shall have a minimum thermal efficiency of 80% and incorporate agency listed gas-fired duct furnace(s) per UL, CSA, or ETL for operation on natural or propane gas to the current edition of ANSI Z83.8 or Canadian CSA 2.6 Standard for Gas-Fired Duct Furnaces. Duct furnaces shall be installed on the positive pressure side of the supply fan only.

- B. The duct furnace modules shall have:

1. 20 gage galvanized steel heat exchanger cabinet.
2. 1 in. thick, minimum 1 1/2 lb per cu ft density thermal insulation for the heat exchanger cabinet.
3. Each furnace shall have an induced-draft fan for the removal of flue gases and to keep the heat exchanger at a negative pressure.
4. Air pressure switches to prove air supply for combustion before operation of gas valve.

5. Patented inshot gas burners with integral carry-overs.
  6. Direct-spark ignition of the gas burners with remote flame sensor to prove carryover across all burners.
  7. A listed 24-vac redundant combination gas valve including two electric shutoff valves, gas pressure regulator, and a manual shutoff valve per furnace.
  8. An automatic reset type high limit switch to limit maximum outlet air temperature to less than 250 F.
  9. Manual reset flame rollout switches.
  10. Minimum of one 40 va, 24 vac control transformer.
  11. 1/8 in. NPT tapped test gage connection in the gas manifold for measuring gas pressure.
  12. Union fitting downstream of gas control to facilitate installation and service
  13. Provision for attachment of a vent system to exhaust flue gases to the outdoors.
- C. Gas-fired duct furnace(s) provided shall have an 18 gage tubular heat exchanger assembly suitable to withstand 3.0 in. wg total external static pressure without burner flame disturbance and constructed of either:
1. Type 409 stainless steel (0.044 minimum wall thickness) produced to ASTM A268.
  2. Type 304L stainless tubes (0.047 minimum wall thickness) produced to ASTM A249.
- D. Gas heating section modules shall be listed for application downstream of refrigeration and cooling systems and shall provide means for removal of condensate that occurs in the tubes during cooling operation. Heat exchanger tubes shall have (integral formed dimpled restrictors; formed tubulators) to provide for an unobstructed drainage path and tubes shall be formed to provide a positive pitch to promote condensate drainage. Drainage shall be configured so that burners and burner surfaces are not exposed to condensate.
- E. Gas heating section shall incorporate a direct-spark ignition control module listed by one of the following: US, CSA, or ETL.
- F. Controls shall provide:
1. 100% safety shutoff.
  2. A 15-second minimum pre-purge period prior to trial for ignition.
  3. High-energy direct-spark ignition of main burners.
  4. Electronic flame supervision incorporating a 0.8-second flame failure response time.
  5. Up to 2 additional ignition retries preceded by an inter-purge period.
  6. A minimum 30-second post-purge.
  7. Automatic reset after one hour to initiate additional ignition trials if lockout occurs during heat call.
  8. An LED indicator light to provide a flash code to identify the operating condition of the control.
- G. Gas heating section shall be equipped for operation with 115 vac, single-phase, 60 Hz power supply.
- H. All electrical components shall be listed or recognized by UL, CSA, or ETL.
- I. Gas Furnace Control:
1. Single furnace — Operates from 10 to 100% of input from a single analog input of 0 to 10 vdc.
  2. Two furnaces in series — Lead unit operates from 20 to 100% of input and secondary unit operates in two-stage operation to achieve overall system input of 10 to 100% from a single analog input of 0 to 10 vdc.
  3. Furnace rack systems — Multiple furnaces operate from a single analog input of 0 to 10 vdc with a lead modulating furnace and multiple secondary two-stage furnaces to achieve overall system input of 10 to 100%. (10:1 turndown minimum; most rack systems provide greater than 10:1 turndown.)
- J. Electronic modulation — Operates from 10 to 100% of input from a single analog input of 0 to 10 vdc. Heat enable contact (supplied by others) initiates and ends heating cycles. Heating unit incorporates two-speed operation of combustion air blower and two-stage gas valve, signal amplifier and timer relay control.
- K. Gas supply pressure to the gas valve inlet shall be 5.0 to 13.5 in. wg for natural gas or 11.0 to 13.5 in. wg for propane gas.
- L. Units are orificed for operation up to 2000 ft above sea level unless specified for high altitude operation.
- M. Duct furnaces shall be test-fired prior to shipment to verify proper ignition, operation and shutdown and satisfactory operation of all components.
- N. Furnaces shall be provided with printed installation and maintenance instructions, burner operating and maintenance instructions, piping and wiring diagrams and installation start-up data sheet.

## 2.07 HUMIDIFIERS

- A. The humidifiers shall be of the direct discharge type, using steam from existing steam lines or boilers to be injected into the air plenums for humidification.
- B. Each humidifier shall consist of multiple, vertical steam discharge pipes, supported on horizontal header manifolds, spaced to provide the optimum of steam to air contact while minimizing pressure drop. Each humidifier shall be sized to nominally match the air plenum width and height for maximum contact of the discharging steam to the air passing around the vertical steam discharge pipes.

- C. The vertical steam discharge pipes shall be constructed of 316 stainless steel. Each pipe shall have a full-length, inverted slot on each side for steam discharge at 100% air to steam contact. Nozzles and holes have less than 15% air to steam contact and are, therefore, unacceptable.
- D. A full-length stainless steel fishbone shaped baffle shall be used inside the vertical discharge pipe to wick condensate away from the discharge slots and back to the center of the pipe for re-evaporation.
- E. The feeder manifolds shall be constructed of 316 stainless steel, sized to move the steam in a specific mass-flow speed range, for maximum condensate separation. Final condensate separation shall occur inside the feeder manifolds, after the control valve, with the dried steam then injected directly into the vertical discharge pipes.
- F. Insulated uprights provide a cushion of air that reduces both heat gain and condensate formation. Insulated models have nozzles inserted in the uprights to ensure that only dry steam is delivered into the air.
- G. The steam humidifier shall be designed with slip fittings for easy assembly. The steam humidifier shall be designed without plastic nozzles, collars, o-rings or gaskets for zero maintenance.

## 2.08 FILTER SECTIONS

- A. Flat filter sections shall accept either 2-in. or 4-in. filters. Sections shall include side access slide rails. Optional 2 in. pre-filter shall be available.
- B. Angle filter sections shall accept either 2-in. or 4-in. filters of standard sizes, arranged in a horizontal V formation.
- C. Draw-thru bag/cartridge filter sections shall be capable of accepting headered standard size 6-in. to 12-in. deep rigid media or bag filters and a 2-in. pre-filter.
- D. Draw-thru bag/cartridge filter sections shall be capable of accepting headered standard size 12-in. to 30-in. deep rigid media or bag filters and a 2-in. pre-filter.
- E. Blow-thru bag/cartridge filter sections shall contain a face loading filter frame and be capable of accepting standard size 12-in. deep rigid media (headered or box) or bag filters.
- F. Blow-thru HEPA filter sections shall contain a face loading filter frame and be capable of accepting standard size 12-in. deep HEPA box filters.
- G. Differential Pressure Gages:
  - 1. Housing shall be constructed of a glass filled nylon case and acrylic lens. Exterior finish shall be coated black.
  - 2. Accuracy shall be  $\pm 5\%$  of full scale throughout range at 70 F.
  - 3. Pressure limits shall be 30 psig continuous to either pressure connection.
  - 4. Temperature limits shall be 20 to 120 F.

- 5. Diameter of dial face shall be 2.33 in.
- 6. Process connections shall be barbed,  $\frac{3}{16}$ -in. for ID tubing.

## 2.09 DAMPERS

- A. Factory-supplied dampers shall be warranted to be free from defects in material and workmanship for a period of 12 months after being installed or placed in service, but in no instance shall the period of warranty be longer than 18 months from the date of the original shipment by the manufacturer.
- B. Mixing boxes, filter-mixing boxes, and exhaust boxes shall have parallel or opposed blades and interconnecting outside-air and return-air dampers.
  - 1. Standard Dampers:
    - Damper blades shall be constructed of galvanized steel, with blade seals and stainless steel jamb seals. Blades shall be mechanically fastened to axle rods rotating in self-lubricating synthetic bearings. Maximum leakage rate shall be 4 cfm/ft<sup>2</sup> at 1 in. wg differential pressure.
  - 2. Premium Dampers:
    - Damper blades shall be constructed of galvanized steel with a double-skin airfoil design, with blade seals and stainless steel jamb seals. Blades shall be mechanically fastened to axle rods rotating in self-lubricating synthetic bearings. Maximum leakage rate shall be 2 cfm/ft<sup>2</sup> at 1 in. wg differential pressure.
  - 3. Outside Air Measurement Dampers:
    - a. Damper frame shall be nominal 4 in. x 1 in. x minimum 0.081 in. and constructed of 6063-T5 extruded aluminum.
    - b. Airflow measuring blades shall be airfoil-shaped, heavy gage anodized 6063-T5 extruded aluminum and fixed in 10 in. x minimum 16 gage galvanized steel frame.
    - c. Jamb seals shall be flexible metal compression type along control damper sides.
    - d. Blade seals shall be neoprene along control damper blade edges.
    - e. Bearings shall be molded synthetic.
    - f. Linkage shall be galvanized steel, concealed in frame.
    - g. Axles shall be minimum  $\frac{1}{2}$ -in. diameter plated steel, hex-shaped, mechanically attached to blade.
    - h. Operating temperature shall be -22 to 140 F.
    - i. Air straightener section shall be aluminum alloy honeycomb contained in 5 in. long, 16 gage galvanized steel sleeve attached to monitoring blade frame.
    - j. Airflow range shall be 400 to 5,000 ft per minute face velocity.
    - k. Maximum leakage rate shall be 2 cfm/ft<sup>2</sup> at 1 in. wg differential pressure.

## C. Integral Face and Bypass Dampers:

1. Integral face and bypass (IFB) coils shall be capable of maintaining a constant air volume, within 5%, shall be capable of maintaining a constant leaving air temperature as entering air conditions vary, and shall be capable of producing mixed leaving air temperatures within 3 ft downstream with a maximum variance in air temperature of 5° F, regardless of damper position.
2. When no heating is required, dampers shall divert air to bypass around heating surface with minimal temperature override.
3. Coil casing, dampers and baffles shall be fabricated from galvanized steel with an option for stainless steel. Coils shall be tested at 300 psig.
4. Integral face and bypass coils shall be provided with a connection point for field-mounted actuator(s), electrical or pneumatic, or can be provided from the factory at an additional cost.
5. Actuator connection point shall be mechanically attached to dampers via linkage mechanisms. Dampers shall be interconnected for operation simultaneously across each face of coil.

## D. Internal Face and Bypass Dampers:

Internal face and bypass dampers shall be factory mounted in galvanized steel frame. Damper blades shall be constructed of galvanized steel, with high temperature blade and edge seals. Blades shall be mechanically fastened to axle rods rotating in self-lubricating synthetic bearings. To eliminate blade warping, face dampers shall be sectionalized to limit blade length to 60 in. maximum. Face damper blades shall be opposed and arranged to match coil face with top bypass, and internal linkage.

## E. Power Exhaust Hood Dampers:

Backdraft damper blades shall be 6063-T5 extruded aluminum channel with galvanized steel braces and extruded vinyl blade seals. Blades shall be mechanically fastened to axle rods rotating in corrosion-resistant, synthetic bearings. Blades begin to open at 0.12 in. wg and are fully open at 0.2 in. wg.

## 2.10 AIR MIXER

Air mixer of 0.081-in. aluminum construction of size, performance and maximum pressure drop indicated. The air mixer shall mix two or more airstreams of differing temperature to within  $\pm 6^\circ$  F of theoretical mixed-air temperature and provide a more uniform air velocity contour entering a downstream filter or coil bank.

## 2.11 UV-C GERMICIDAL LAMPS

- A. Emitters and fixtures for UV-C lamps shall be designed for use inside an HVAC system and shall be covered by a 1 year warranty. Individual lamp output shall be measured in an ASME nozzled test apparatus using a 45 F airstream moving at not less than 400 fpm. Lamp output at 253.7 nm shall not

be less than  $10 \mu\text{W}/\text{cm}^2$  per inch of arc length measured at a distance of one meter.

- B. Power supplies for UV-C lamps shall be a high-efficiency electronic type which are matched to the emitters and are capable of producing the specified output intensity with an input power no more than 80 watts.
- C. Fixtures for UV-C lamps shall be factory installed and wired to a SPDT disconnect switch and door interlock switches in each door. Fixtures are wired for 120 v/single ph requiring a minimum circuit ampacity of 15 amps. Lamps shall ship separately for field installation to minimize the chance for bulb damage.
- D. Emitters and fixtures shall be installed in sufficient quantity and arranged so as to provide an equal distribution of UV-C energy on the coil and drain pan.
- E. The minimum UV-C energy striking the leading edge of the coil pan shall be not less than  $820 \mu\text{W}/\text{cm}^2$  at the closest point and through placement, not less than 60% of that value at the farthest point. Equal amounts are to strike the drain pan, either directly or indirectly through reflection.
- F. Emitters and fixtures shall be installed such that UV-C energy strikes all surfaces of the coil, drain pan, and the available line of sight airstream.

## 2.12 ELECTRICAL ACCESSORIES

### A. Marine Lights and Convenience Outlets:

1. Cast, non-ferrous metal, weatherproof, fixture.
2. Cast, non-ferrous metal, weatherproof, electrical junction box.
3. Gasketed, heat and shock resistant glass globe protects against moisture and debris.
4. Cast, non-ferrous metal lamp guard to protect glass globe.
5. UL and CSA listed.
6. 100 watt type 'A' lamp maximum capacity.
7. Each fixture is equipped with a 9.5 watt, 120 volt, 800 lumen LED lamp with an average rated life of 25,000 hours, factory installed.
8. Cast, non-ferrous metal, single gang, weatherproof, switch enclosure.
9. With convenience outlet: Factory supplied and wired, SPST, toggle switch and 15 amp, 120 vac/60 Hz, NEMA 5-15 type, ground fault circuit interrupt (GFCI) receptacle, weatherproof, 'In-Use' type, lockable cover, UL listed.
10. Without convenience outlet: Factory supplied and wired, SPST switch with non-ferrous metal, weatherproof cover plate, UL listed.
11. Each fixture is factory wired to an externally mounted switch box. (Field power connections are made to the switch box mounted externally on the unit.)
12. All factory wiring penetrating through the panel is protected in 'RIGID' type metal conduit.

## B. Disconnects:

Factory-supplied disconnects shall be covered under a 1 year limited warranty from the manufacturer from the date of shipment.

1. 115-230 volt/single-phase non-fused disconnects shall have the following characteristics:
  - a. Plated current carrying components for superior corrosion protection.
  - b. Factory-installed equipment grounding terminals with slot/square drive screws.
  - c. Rated for motor disconnect applications (10 hp maximum).
  - d. NEMA type 3R non-metallic enclosure.
  - e. Up to 10,000 rms symmetrical amperes SCCR, when protected by a fuse or circuit breaker rated 60 amperes or less.
  - f. Cover padlock hasp.
  - g. Pull-out cartridge type.
  - h. UL listed.
2. 115-230 volt/single-phase fused disconnects shall have the following characteristics:
  - a. Visible blades.
  - b. Quick-make, quick-break operating mechanism.
  - c. Cover padlock hasp and handle lock "OFF."
  - d. 240 vac maximum.
  - e. Factory supplied and installed class RK5 fuses.
  - f. Up to 100,000 rms symmetrical amperes SCCR, utilizing appropriately rated, factory supplied, Class R fuses.
  - g. Horsepower rated for motor applications.
  - h. Tangential combination knockouts for field wiring.
  - i. Spring reinforced plated copper fuse clips.
  - j. NEMA type 3R enclosures.
  - k. Insulated, bondable solid neutral assemblies.
  - l. UL listed, File E2875.
  - m. Meet or exceed NEMA KS1-1990.
3. 200-230 volt/3-phase fused and non-fused disconnects shall have the following characteristics:
  - a. Visible blades.
  - b. Quick-make, quick-break operating mechanism.
  - c. Cover padlock hasp and handle lock "OFF."
  - d. 240 vac maximum.
  - e. Factory supplied and installed class RK5 fuses (fused disconnects only).
  - f. Up to 100,000 rms symmetrical amperes SCCR, utilizing appropriately rated Class R fuses.
  - g. Horsepower rated for motor applications.
  - h. Tangential combination knockouts for field wiring.

- i. Spring reinforced plated copper fuse clips.
  - j. NEMA type 3R enclosures.
  - k. Insulated, bondable solid neutral assemblies.
  - l. UL listed, File E2875.
  - m. Meet or exceed NEMA KS1-1990.
4. 380-575 volt/3-phase fused and non-fused disconnects shall have the following characteristics:
    - a. Visible switch blades with for positive "OFF" indication.
    - b. Quick-make, quick-break operating mechanism.
    - c. Dual cover interlock.
    - d. Color coded "ON" — "OFF" indicator handle.
    - e. Cover padlock hasp and handle lock "OFF" provision for multiple padlocks.
    - f. 600 vac maximum.
    - g. Factory supplied and installed class RK5 fuses (fused disconnects only).
    - h. Up to 200,000 rms symmetrical amperes SCCR, utilizing appropriately rated Class R fuses.
    - i. Horsepower rated for motor applications.
    - j. Spring reinforced plated copper fuse clips.
    - k. Tangential combination knockouts.
    - l. NEMA type 3R enclosures.
    - m. Insulated, bondable solid neutral assemblies.
    - n. Wire terminations suitable for aluminum or copper conductors.
    - o. UL listed.
    - p. Meet or exceed NEMA KS1-1999.

## C. Starters:

Factory-supplied disconnects shall be covered under a 1 year limited warranty from the manufacturer from the date of shipment.

1. Starter without disconnect:
  - a. Adjustable motor overload with trip indication.
  - b. Manual overload reset button (accessible without opening enclosure).
  - c. 115-v fused secondary control transformer (fuse included — fused primary and secondary over 50 amps).
  - d. Hand/Off/Auto selector switch (accessible without opening enclosure).
  - e. Separate 4-position terminal strip for remote H-O-A wiring.
  - f. C series contactors.
  - g. Horsepower rated for motor applications.
  - h. NEMA 4X type non-metallic enclosures.
  - i. Lug connections for field wiring.
  - j. Factory mounted, wired, and run tested with factory-supplied motor.

- k. UL listed.
- 2. Combination Starter/Disconnect:
  - a. Non-fused UL 508 disconnect switch with lockable handle (locks not provided).
  - b. Cover interlock.
  - c. Adjustable motor overload with trip indication.
  - d. Manual overload reset button (accessible without opening enclosure).
  - e. 115-v fused secondary control transformer (fuse included — fused primary and secondary over 50 amps).
  - f. Hand/Off/Auto selector switch (accessible without opening enclosure).
  - g. Separate 4-position terminal strip for remote H-O-A wiring.
  - h. C series contactors.
  - i. Horsepower rated for motor applications.
  - j. NEMA 4X type non-metallic enclosures.
  - k. Lug connections for field power wiring.
  - l. Factory mounted, wired, and run tested with factory-supplied motor.
- D. Bypass for Variable Frequency Drives:

Factory-supplied bypasses shall be covered under a 1 year limited warranty from the manufacturer from the date of shipment.

  - 1. 200-230 v /3 Ph/60 Hz (1 to 7.5 Hp), 460-575 v/3 Ph/60 Hz (1 to 20 Hp), 380 v/3 Ph/50 Hz (1 to 15 Hp):
    - a. 4-position panel-mounted disconnect style switch with lockable handle (locks not provided), meets OSHA 1910.
    - b. Switch position indication (LINE/OFF/DRIVE/TEST).
    - c. Adjustable motor overload with trip indication (LINE position).
    - d. Manual overload reset button.
    - e. Horsepower rated for motor applications.
    - f. Direct control (no contactors, relays, or holding coils).
    - g. Complete isolation of inverter in LINE position.
    - h. NEMA 4 type metal enclosures.
    - i. Terminal strip provided for field power supply wiring.
    - j. Lug connection for field ground wire.
    - k. Gold flashed, auxiliary switch contact set (for switch position monitoring).
    - l. Factory mounted, wired to VFD and motor, and run tested (motor and VFD must be factory supplied and installed).
    - m. UL; UL, Canada; CE listed.
  - 2. 200-230 v /3 Ph/60 Hz (10 to 75 Hp), 460-575 v/3 Ph/60 Hz (25 to 150 Hp), 380 v/3 Ph/50 Hz (20 to 75 Hp):
    - a. 4-position panel-mounted disconnect style switch with lockable handle (locks not provided), meets OSHA 1910.
    - b. Switch position indication (LINE/OFF/DRIVE/TEST).
    - c. Adjustable motor overload with trip indication (in LINE position).
    - d. Manual overload reset button.
    - e. Horsepower rated for motor applications.
    - f. 115-v control transformer with fused secondary (fused primary on units over 50 amps).
    - g. Contactor for Line Start/Stop.
    - h. Door-mounted Line Start and Line Stop pushbuttons.
    - i. Complete isolation of inverter in LINE position.
    - j. NEMA 12 type metal enclosures.
    - k. Terminal strip provided for field power supply wiring.
    - l. Lug connection for field ground wire.
    - m. Gold flashed, auxiliary switch contact set (for switch position monitoring).
    - n. Factory mounted, wired to VFD and motor, and run tested (motor and VFD must be factory supplied and installed).
    - o. UL; UL, Canada; CE listed.
- E. Variable Frequency Drives:
  - 1. Factory-mounted variable frequency drives (VFDs) shall be wired to factory-supplied motors.
  - 2. Factory-supplied VFDs are programmed and started up from the factory and qualify the VFD, through ABB, for a 24-month warranty from date of commissioning or 30 months from date of sale, whichever occurs first.
  - 3. The VFD parameters are programmed into the controller and removable keypad. In the event that the VFD fails and needs replacement, the program can then be uploaded to the replacement VFD via the original keypad.
  - 4. The VFD shall be mounted inside the unit cabinet shielded from upstream components and within the unit's ambient conditions. Access to the VFD shall be through the unit's hinged access door.
  - 5. The VFD package as specified herein shall be enclosed in a UL Listed type enclosure, exceeding NEMA enclosure design criteria (enclosures with only NEMA ratings are not acceptable), completely assembled and tested by the manufacturer in an ISO 9001 facility. The VFD tolerated voltage window shall allow the VFD to



operate from a line of +30% nominal, and -35% nominal voltage as a minimum.

- a. Environmental operating conditions: VFDs shall be capable of continuous operation at -15 to 40 C (5 to 104 F) ambient temperature with no frost allowed as per VFD manufacturers documented/submittal data or VFD must be oversized to meet these temperature requirements. Not acceptable are VFDs that can only operate at 40 C intermittently (average during a 24-hour period) and therefore must be oversized. VFDs shall be capable of operating at altitude 0 to 3300 ft above sea level and less than 95% humidity, non-condensing. All circuit boards shall have conformal coating.
  - b. Enclosure shall be rated UL Type 1 and shall be UL listed as a plenum rated VFD. VFDs without these ratings are not acceptable. Type 1 enclosures with only NEMA ratings are not acceptable (must be UL Type 1).
6. All VFDs shall have the following standard features:
- a. All VFDs shall have the same customer interface, including digital display, and keypad, regardless of horsepower rating. The keypad shall be removable, capable of remote mounting and allow for uploading and downloading of parameter settings as an aid for start-up of multiple VFDs.
  - b. The keypad shall include Hand-Off-Auto selections and manual speed control. The drive shall incorporate "bumpless transfer" of speed reference when switching between "Hand" and "Auto" modes. There shall be fault reset and "Help" buttons on the keypad. The Help button shall include "on-line" assistance for programming and troubleshooting.
  - c. There shall be a built-in timeclock in the VFD keypad. The clock shall have a battery back-up with 10 years minimum life span. The clock shall be used to date and time stamp faults and record operating parameters at the time of fault. If the battery fails, the VFD shall automatically revert to hours of operation since initial power up. Capacitor back-up is not acceptable. The clock shall also be programmable to control start/stop functions, constant speeds, PID parameter sets and output Form-C relays. The VFD shall have a digital input that allows an override to the timeclock (when in the off mode) for a programmable time frame. There shall be four (4) separate, independent timer functions that have both weekday and weekend settings.
  - d. The VFDs shall utilize pre-programmed application macros specifically designed to facilitate start-up. The Application Macros shall provide one command to reprogram all parameters and customer interfaces for a particular application to reduce programming time. The VFD shall have two user macros to allow the end-user to create and save custom settings.
  - e. The VFD shall have cooling fans that are designed for easy replacement. The fans shall be designed for replacement without requiring removing the VFD from the wall or removal of circuit boards. The VFD cooling fans shall operate only when required. To extend the fan and bearing operating life, the VFD shall cycle the cooling fans on and off as required.
  - f. The VFD shall be capable of starting into a coasting load (forward or reverse) up to full speed and accelerate or decelerate to set point without tripping or component damage (flying start).
  - g. The VFD shall have the ability to automatically restart after an overcurrent, over-voltage, under-voltage, or loss of input signal protective trip. The number of restart attempts, trial time, and time between attempts shall be programmable.
  - h. The overload rating of the drive shall be 110% of its normal duty current rating for 1 minute every 10 minutes, 130% overload for 2 seconds. The minimum FLA rating shall meet or exceed the values in the NEC/UL table 430.250 for 4-pole motors.
  - i. The VFD shall have internal 5% impedance reactors to reduce the harmonics to the power line and to add protection from AC line transients. The 5% impedance may be from dual (positive and negative DC bus) reactors, or 5% AC line reactors. VFDs with only one DC reactor shall add an AC line reactor.
  - j. The input current rating of the VFD shall be no more than 3% greater than the output current rating. VFDs with higher input current ratings require the upstream wiring, protection devices, and source transformers to be oversized per NEC 430.120. Input and output current ratings must be shown on the VFD nameplate.
  - k. The VFD shall include a coordinated AC transient surge protection system consisting of 4 to 120 joule rated MOVs (phase to phase and phase to ground), a capacitor clamp, and 5% impedance reactors.
  - l. The VFD shall provide a programmable loss-of-load (broken belt/broken coupling) Form-C relay output. The drive shall be programmable to signal the loss-of-load condition via a keypad warning, Form-C relay output, and/or over the serial communications bus.

The loss-of-load condition sensing algorithm shall include a programmable time delay that will allow for motor acceleration from zero speed without signaling a false loss-of-load condition.

- m. The VFD shall have user programmable underload and overload curve functions to allow user defined indications of broken belt or mechanical failure/jam condition causing motor overload
  - n. The VFD shall include multiple “two zone” PID algorithms that allow the VFD to maintain PID control from two separate feedback signals (4 to 20 mA, 0 to 10V, and/or serial communications). The two zone control PID algorithm will control motor speed based on a minimum, maximum, or average of the two feedback signals. All of the VFD PID controllers shall include the ability for “two zone” control.
  - o. If the input reference (4 to 20 mA or 2 to 10 V) is lost, the VFD shall give the user the option of either (1) stopping and displaying a fault, (2) running at a programmable preset speed, (3) hold the VFD speed based on the last good reference received, or (4) cause a warning to be issued, as selected by the user. The drive shall be programmable to signal this condition via a keypad warning, Form-C relay output and / or over the serial communication bus.
  - p. The VFD shall have programmable “Sleep” and “Wake up” functions to allow the drive to be started and stopped from the level of a process feedback signal.
7. All VFDs to have the following adjustments:
- a. Three (3) programmable critical frequency lockout ranges to prevent the VFD from operating the load continuously at an unstable speed. The lockout range must be fully adjustable, from 0 to full speed.
  - b. Two (2) PID set point controllers shall be standard in the drive, allowing pressure or flow signals to be connected to the VFD, using the microprocessor in the VFD for the closed-loop control. The VFD shall have 250 mA of 24 VDC auxiliary power and be capable of loop powering a transmitter supplied by others. The PID set point shall be adjustable from the VFD keypad, analog inputs, or over the communications bus. There shall be two independent parameter sets for the PID controller and the capability to switch between the parameter sets via a digital input, serial communications or from the keypad. The independent parameter sets are typically used for night setback, switching between summer and winter set points, etc.
  - c. There shall be an independent, second PID loop that can utilize the second analog input and modulate one of the analog outputs to maintain the set point of an independent process (ie. valves, dampers, etc.). All set points, process variables, etc. to be accessible from the serial communication network.
  - d. Two (2) programmable analog inputs shall accept current or voltage signals.
  - e. Two (2) programmable analog outputs (0 to 20 mA or 4 to 20 mA). The outputs may be programmed to output proportional to Frequency, Motor Speed, Output Voltage, Output Current, Motor Torque, Motor Power (kW), DC Bus voltage, Active Reference, Active Feedback, and other data.
  - f. Six (6) programmable digital inputs for maximum flexibility in interfacing with external devices. All digital inputs shall be programmable to initiate upon an application or removal of 24 VDC or 24 VAC.
  - g. Three (3) programmable, digital Form-C relay outputs. The relay outputs shall include programmable on and off delay times and adjustable hysteresis. The relays shall be rated for maximum switching current 8 amps at 24 VDC and 0.4 A at 250 VAC; Maximum voltage 300 VDC and 250 VAC; continuous current rating of 2 amps RMS. Outputs shall be true Form-C type contacts; open collector outputs are not acceptable.
  - h. Run permissive circuit: There shall be a run permissive circuit for damper or valve control. Regardless of the source of a run command (keypad, input contact closure, time-clock control, or serial communications), the VFD shall provide a dry contact closure that will signal the damper to open (VFD motor does not operate). When the damper is fully open, a normally open dry contact (end-switch) shall close. The closed end-switch is wired to a VFD digital input and allows VFD motor operation. Two separate safety interlock inputs shall be provided. When either safety is opened, the motor shall be commanded to coast to stop and the damper shall be commanded to close. The keypad shall display “start enable 1 (or 2) missing.” The safety input status shall also be transmitted over the serial communications bus.
  - i. The VFD control shall include a programmable time delay for VFD start and a keypad indication that this time delay is active. A Form C relay output provides a contact closure to signal the VAV boxes open. This will allow VAV boxes to be driven open before the motor operates. The time delay shall be field programmable from 0 to 120 seconds. Start delay shall be active regardless

- of the start command source (keypad command, input contact closure, time-clock control, or serial communications).
- j. Seven (7) programmable preset speeds.
  - k. Two independently adjustable accelerate and decelerate ramps with 1 to 1800 seconds adjustable time ramps.
  - l. The VFD shall include a motor flux optimization circuit that will automatically reduce applied motor voltage to the motor to optimize energy consumption and reduce audible motor noise. The VFD shall have selectable software for optimization of motor noise, energy consumption, and motor speed control.
  - m. The VFD shall include a carrier frequency control circuit that reduces the carrier frequency based on actual VFD temperature that allows higher carrier frequency settings without derating the VFD.
  - n. The VFD shall include password protection against parameter changes.
8. The keypad shall include a backlit LCD display. The display shall be in complete English words for programming and fault diagnostics (alpha-numeric codes are not acceptable). All VFD faults shall be displayed in English words. The keypad shall include a minimum of 14 assistants including:
    - a. Start-up assistant
    - b. Parameter assistants
    - c. PID assistant
    - d. Reference assistant
    - e. I/O assistant
    - f. Serial communications assistant
    - g. Option module assistant
    - h. Panel display assistant
    - i. Low noise set-up assistant
    - j. Maintenance assistant
    - k. Troubleshooting assistant
    - l. Drive optimizer assistants
  9. All applicable operating values shall be capable of being displayed in engineering (user) units. A minimum of three operating values from the list below shall be capable of being displayed at all times. The display shall be in complete English words (alpha-numeric codes are not acceptable):
    - a. Output Frequency
    - b. Motor Speed (RPM, %, or Engineering units)
    - c. Motor Current
    - d. Motor Torque
    - e. Motor Power (kW)
    - f. DC Bus Voltage
    - g. Output Voltage
  10. The VFD shall include a fireman's override input. Upon receipt of a contact closure from the fire / smoke control station, the VFD shall operate in one of two modes: 1) Operate at a programmed predetermined fixed speed ranging from -500 Hz (reverse) to 500 Hz (forward). 2) Operate in a specific fireman's override PID algorithm that automatically adjusts motor speed based on override set point and feedback. The mode shall override all other inputs (analog/digital, serial communication, and all keypad commands), except customer defined safety run interlocks, and force the motor to run in one of the two modes above. "Override Mode" shall be displayed on the keypad. Upon removal of the override signal, the VFD shall resume normal operation, without the need to cycle the normal digital input run command.
  11. Serial Communications:
    - a. The VFD shall have an EIA-485 port as standard. The standard protocols shall be Modbus, Johnson Controls N2, Siemens Building Technologies FLN, and BACnet. [Optional protocols for LonWorks, Profibus, EtherNet, BACnet IP, and DeviceNet shall be available.] Each individual drive shall have the protocol in the base VFD. The use of third party gateways and multiplexers is not acceptable. All protocols shall be "certified" by the governing authority (i.e., BTL Listing for BACnet). Use of non-certified protocols is not allowed.
    - b. The BACnet connection shall be an EIA-485, MS/TP interface operating at 9.6, 19.2, 38.4, or 76.8 Kbps. The connection shall be tested by the BACnet Testing Labs (BTL) and be BTL Listed. The BACnet interface shall conform to the BACnet standard device type of an Applications Specific Controller (B-ASC). The interface shall support all BIBBs defined by the BACnet standard profile for a B-ASC including, but not limited to:
      - 1) Data Sharing – Read Property – B.
      - 2) Data Sharing – Write Property – B.
      - 3) Device Management – Dynamic Device Binding (Who-Is; I-Am).
      - 4) Device Management – Dynamic Object Binding (Who-Has; I-Have).
      - 5) Device Management – Communication Control – B.
    - c. If additional hardware is required to obtain the BACnet interface, the VFD manufacturer shall supply one BACnet gateway per drive. Multiple VFDs sharing one gateway shall not be acceptable.
    - d. Serial communication capabilities shall include, but not be limited to; run-stop control, speed set adjustment, proportional/

integral/derivative PID control adjustments, current limit, accel/decel time adjustments, and lock and unlock the keypad. The drive shall have the capability of allowing the DDC to monitor feedback such as process variable feedback, output speed / frequency, current (in amps), % torque, power (kW), kilowatt hours (resettable), operating hours (resettable), and drive temperature. The DDC shall also be capable of monitoring the VFD relay output status, digital input status, and all analog input and analog output values. All diagnostic warning and fault information shall be transmitted over the serial communications bus. Remote VFD fault reset shall be possible.

- e. The VFD shall include an independent PID loop for customer use. The independent PID loop may be used for cooling tower bypass valve control, chilled water valve / hot water valve control, etc. Both the VFD PID control loop and the independent PID control loop shall continue functioning even if the serial communications connection is lost. As default, the VFD shall keep the last good set point command and last good DO and AO commands in memory in the event the serial communications connection is lost and continue controlling the process.
12. EMI/RFI filters. All VFDs shall include EMI/RFI filters. The onboard filters shall allow the VFD assembly to be CE Marked and the VFD shall meet product standard EN 61800-3 for the First Environment restricted level with up to 100 feet of motor cable. No Exceptions. Certified test reports shall be provided with the submittals confirming compliance to EN 61800-3, First Environment.
  13. All VFDs through 75 hp at 480 V shall be protected from input and output power mis-wiring. The VFD shall sense this condition and display an alarm on the keypad. The VFD shall not sustain damage from this power mis-wiring condition.
  14. Operational Functions:
    - a. The drive shall contain two separate acceleration/deceleration times with auto tuning for optimum setting (0.1 to 6000 seconds) with choice of linear, S, or C curves that shall be factory programmed to match the fan load and prevent nuisance overcurrent fault trips.
    - b. The drive shall be equipped with both local/remote and manual/auto keys on touchpad.
    - c. The drive shall be equipped with a quick setup key.
    - d. The drive shall contain 15 preset speeds, which can be activated from the keypad, terminal inputs, and host computer.
    - e. The drive shall have the capability of storable special custom user setting.
    - f. The drive shall restart into a rotating motor operating in either the forward or reverse direction and match that frequency.
    - g. The drive shall have adjustable soft stall (10% to 150%) which reduces frequency and voltage of the inverter to sustain a run in an overload situation factory programmed for each motor's characteristics.
    - h. The drive shall be capable of performing a time base pattern run using 4 groups of 8 patterns each using the 15 preset speed values for a maximum of 32 different patterns.
    - i. The drive shall have adjustable UL listed electronic overload protection (10% to 100%) factory programmed to match each motor's FLA/RLA (full load amps/rated load amps) ratings.
    - j. The drive shall have a custom programmable volt/hertz pattern.
  15. Protective Features:
    - a. The drive shall be rated for 200,000 AIC (ampere interrupting capacity). The use of input fuses to achieve this rating shall not be acceptable.
    - b. The drive shall have external fault input.
    - c. The drive shall be capable of resetting faults remotely and locally.
    - d. The drive shall be programmable to alert the following alarms:
      - 1) Over torque alarm.
      - 2) Inverter overload pre-alarm.
      - 3) Motor overload pre-alarm.
      - 4) Braking resistor overload pre-alarm.
      - 5) Inverter overheat pre-alarm.
      - 6) Undercurrent alarm.
      - 7) Overcurrent pre-alarm.
      - 8) Communication error alarm.
      - 9) Cumulative timer alarm.
      - 10) Executing retry.
    - e. The drive shall identify and display the following faults:
      - 1) Overcurrent during acceleration trip.
      - 2) Overcurrent during deceleration trip.
      - 3) Overcurrent during normal run trip.
      - 4) Overcurrent on the DC Bus during acceleration trip.
      - 5) Overcurrent on the DC Bus during deceleration trip.
      - 6) Overcurrent on the DC Bus during normal run trip.

- 7) Load end overcurrent trip detected at start-up (output terminals, motor wiring, etc.).
- 8) U-phase short circuit trip detected at start-up.
- 9) V-phase short circuit trip detected at start-up.
- 10) W-phase short circuit trip detected at start-up.
- 11) Overvoltage during acceleration trip.
- 12) Overvoltage during deceleration trip.
- 13) Overvoltage during normal (constant speed) run trip.
- 14) Inverter overloaded trip.
- 15) Motor overloaded trip.
- 16) Inverter overheat trip.
- 17) Emergency off trip message.
- 18) EEPROM failure during write cycle.
- 19) EEPROM abnormality during initial reading.
- 20) RAM error.
- 21) ROM error.
- 22) CPU error.
- 23) Communication interruption error.
- 24) Gate array error.
- 25) Output current detection circuit error.
- 26) Option PCB error trip.
- 27) Low operating current trip.
- 28) Main circuit under voltage trip.
- 29) Over torque trip.
- 30) Software detected earth fault trip.
- 31) Hardware detected earth fault trip.
- 32) Inverter type form mismatch error.
- 33) EEPROM type form mismatch error.

16. Monitor Functions:

- a. The drive digital display shall be capable of displaying the following: Frequency, percent current, current amps, percent voltage I/O, voltage in volts I/O, RPM, GPM, I/O watts, torque, and input reference signal, kWh.
  - b. The drive shall have 320 programmable parameters which can be changed while the drive is operating.
  - c. The drive's 353 parameters shall be adjustable from the 8-key touchpad or computer link.
  - d. The drive's 8-key touchpad shall be NEMA 12 rated.
  - e. The drive's keypad shall be capable of being extended 15 ft from the drive.
  - f. The drive shall contain a reset of all parameters to factory default settings or user defaults (whichever one is chosen).
  - g. The drive shall have 2 programmable analog outputs programmable to 17 choices.
  - h. The drive shall have one programmable relay output programmable to 67 choices.
  - i. The drive shall have 8 programmable digital inputs programmable to 54 choices.
  - j. The drive shall have a pulse train output proportional to frequency (48, 96, 360 times frequency).
  - k. The drive shall have an elapsed time meter.
17. Options:
- a. VFD with Integral Disconnect:
    - 1) UL Listed by the drive manufacturer as a complete assembly
    - 2) UL 508 labeled
    - 3) Capable of being locked by three padlocks

