

48ES-A

Comfort™ 13 SEER Single-Packaged Air Conditioner
and Gas Furnace System with Puron® (R-410A)
Refrigerant
Single and Three Phase
2 to 5 Nominal Tons (Sizes 24-60)



Product Data

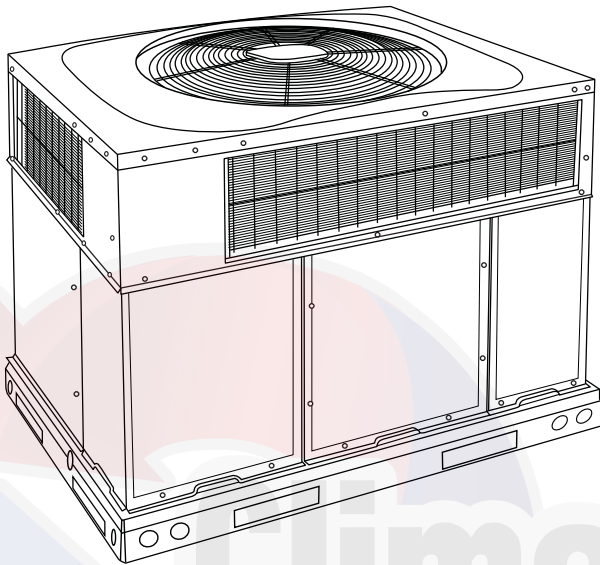

Fig. 1 - Unit 48ES-A

A09034

Single-Packaged Products with Energy-Saving Features and Puron® refrigerant.

- Up to 13.5 SEER
- Up to 80.4% AFUE
- Factory-Installed TXV
- ECM Motor-Standard
- Direct Spark Ignition
- Low Sound Levels
- Dehumidification Feature

FEATURES/BENEFITS

One-piece heating and cooling units with low sound levels, easy installation, low maintenance, and dependable performance.

Puron Environmentally Sound Refrigerant is Carrier's unique refrigerant designed to help protect the environment. Puron is an HFC refrigerant which does not contain chlorine that can harm the ozone layer. Puron refrigerant is in service in millions of systems, proving highly reliable, environmentally sound performance.

Easy Installation

Factory-assembled package is a compact, fully self-contained, combination gas heating/electric cooling unit that is prewired, pre-piped, and pre-charged for minimum installation expense. These units are available in a variety of standard and optional heating/cooling size combinations with voltage options to meet residential and light commercial requirements. Units are lightweight and install easily on a rooftop or at ground level. The high tech composite base eliminates rust problems associated with ground level applications.

Innovative Unit Base Design

On the inside a high-tech composite material will not rust and incorporates a sloped drain pan which improves drainage and helps inhibit mold, algae and bacterial growth. On the outside metal base rails provide added stability as well as easier handling and rigging.

Convertible duct configuration

Unit is designed for use in either downflow or horizontal applications. Each unit is converted from horizontal to downflow and includes horizontal duct covers. Downflow operation is provided in the field to allow vertical ductwork connections. The basepan seals on the bottom openings to ensure a positive seal in the vertical airflow mode.

Efficient operation High-efficiency design offers SEER (Seasonal Energy Efficiency Ratios) of up to 13.5 and AFUE (Annual Fuel Utilization Efficiency) ratings as high as 80.4%.

Energy-saving, direct spark ignition saves gas by operating only when the room thermostat calls for heating. Standard units are furnished with natural gas controls. A low-cost field installed kit for propane conversion is available for all units.

48ESN units are dedicated Low NOx units designed for California installations. These models meet the California maximum oxides of nitrogen (NOx) emissions requirement of 40 nanograms/joule or less as shipped from the factory and MUST be installed in California Air Quality Management Districts and wherever a Low NOx rule exists.

Durable, dependable components Compressors are designed for high efficiency. Each compressor is hermetically sealed against contamination to help promote longer life and dependable operation. Each compressor also has vibration isolation to provide quieter operation. All compressors have internal high pressure and overcurrent protection.

Monoport inshot burners produce precise air-to-gas mixture, which provides for clean and efficient combustion. The large monoport on the inshot (or injection type) burners seldom, if ever, requires cleaning. All gas furnace components are accessible in one compartment.

Turbo-tubular™ heat exchangers are constructed of aluminized steel for corrosion resistance and optimum heat transfer for improved efficiency. The tubular design permits hot gases to make multiple passes across the path of the supply air.

In addition, dimples located on the heat exchanger walls force the hot gases to stay in close contact with the walls, improving heat transfer.

ECM Motor is standard on all 48ES-A models.

Direct-drive PSC (Permanent Split Capacitor) condenser-fan motors are designed to help reduce energy consumption and provide for cooling operation down to 40°F (4.4°C) outdoor temperature. Motormaster® II low ambient kit is available as a field-installed accessory.

Thermostatic Expansion Valve - A hard shutoff, balance port TXV maintains a constant superheat at the evaporator exit (cooling cycle) resulting in higher overall system efficiency.

Refrigerant system is designed to provide dependability. Liquid filter driers are used to promote clean, unrestricted operation. Each unit leaves the factory with a full refrigerant charge. Refrigerant service connections make checking operating pressures easier.

High and Low Pressure Switches provide added reliability for the compressor.

Indoor and Outdoor coils are computer-designed for optimum heat transfer and efficiency. The indoor coil is fabricated from copper tube and aluminum fins and is located inside the unit for protection against damage. The outdoor coil is internally mounted on the top tier of the unit.

Low sound ratings ensure a quiet indoor and outdoor environment with sound ratings as low as 75dBA.

Easy to service cabinets provide easy 3-panel accessibility to serviceable components during maintenance and installation. The basepan with integrated drain pan provides easy ground level installation with a mounting pad. A nesting feature ensures a positive basepan to roof curb seal when the unit is roof mounted. A convenient 3/4-in. (19.05 mm) wide perimeter flange makes frame mounting on a rooftop easy.

Horizontal metal duct covers are standard with insulation come with the unit and cover the horizontal duct openings. These can be left in place if the units are converted to downflow.

Integrated Gas Control (IGC) board provides safe and efficient control of heating and simplifies trouble-shooting through its built-in diagnostic function.

Cabinets are constructed of heavyduty, phosphated, zinc-coated prepainted steel capable of withstanding 500 hours in salt spray. Interior surfaces of the evaporator/heat exchanger compartment are insulated with cleanable semi-rigid insulation board, which keeps the conditioned air from being affected by the outdoor ambient temperature and provides improved indoor air quality. (Conforms to American Society of Heating, Refrigeration and Air Conditioning Engineers 62.2.) The sloped drain pan minimizes standing water in the drain. An external drain is provided.

TABLE OF CONTENTS

Features/Benefits	1–2
Model Number Nomenclature	3
AHRI Capacities	4
Physical Data	5–6
Options and Accessories	7
Base Unit Dimensions	9–10
Accessory Dimensions	11
Selection Procedure	12
Performance Data	13–29
Typical Piping and Wiring	30
Application Data	31
Electrical Data	32
Typical Wiring Schematics	33–38
Controls	39
Guide Specifications	40–41



MODEL NUMBER NOMENCLATURE

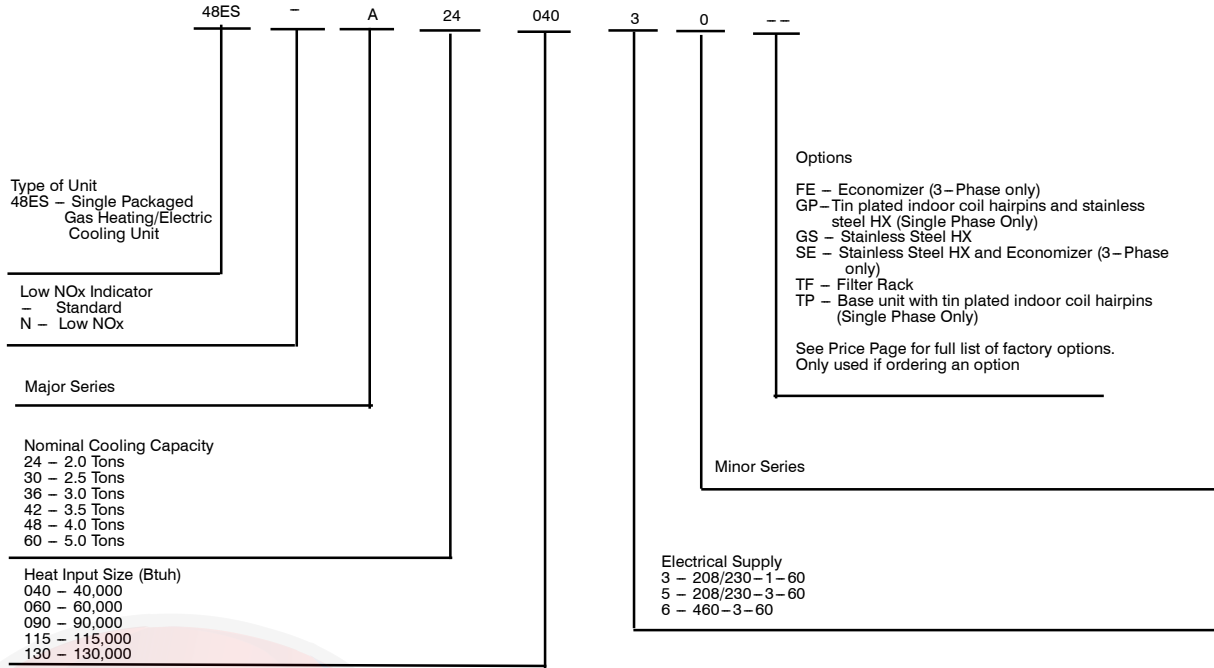

48ES--A

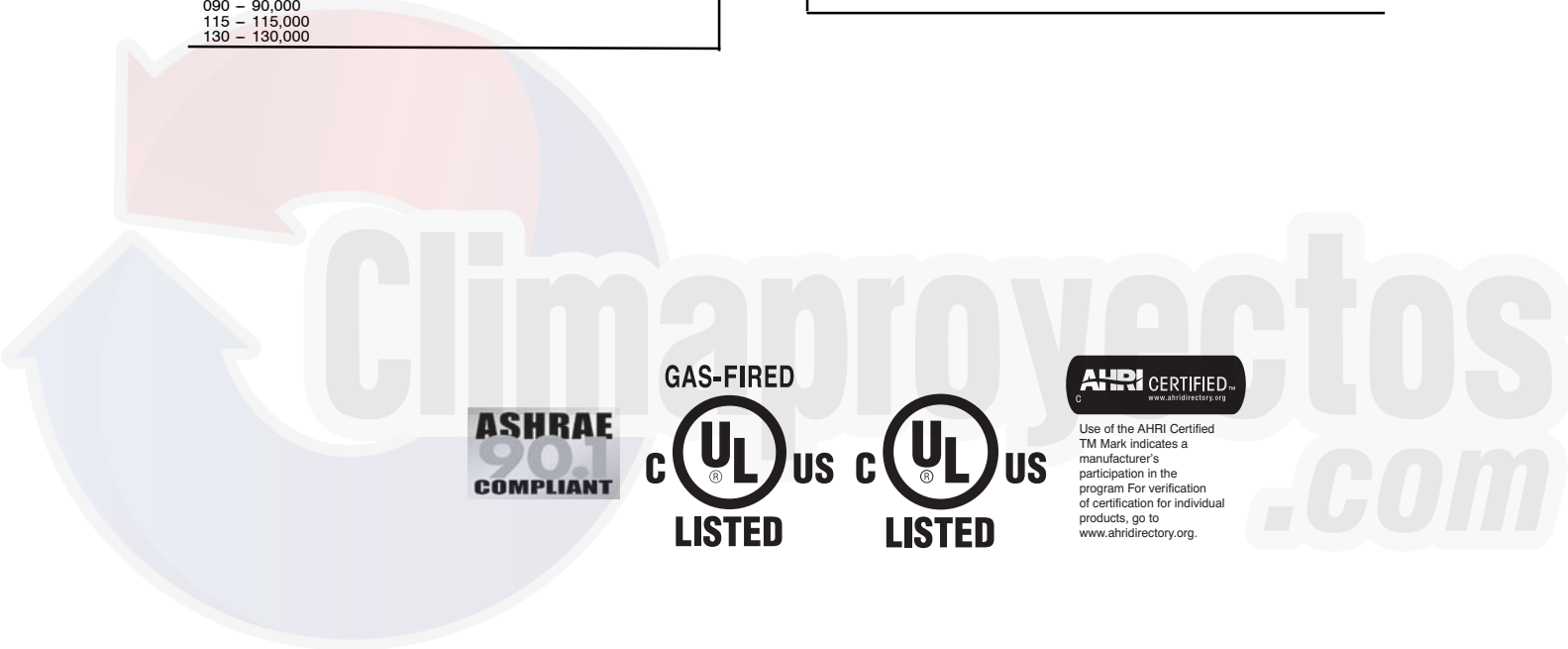

GAS-FIRED



Use of the AHRI Certified TM Mark indicates a manufacturer's participation in the program. For verification of certification for individual products, go to www.ahridirectory.org.

AHRI* CAPACITIES

Cooling Capacities and Efficiencies

UNIT 48ES-A	NOMINAL TONS	STANDARD CFM	NET COOLING CAPACITIES (Btuh)	EER**	SEER†
24	2	800	23,000	11.0	13.2
30	2-1/2	1000	28,400	11.2	13.5
36	3	1200	34,400	11.0	13.0
42	3-1/2	1400	40,500	11.2	13.2
48	4	1600	46,500	11.2	13.2
60	5	1750	57,000	11.0	13.4

LEGEND

dB—Sound Levels (decibels)

db—Dry Bulb

SEER—Seasonal Energy Efficiency Ratio

wb—Wet Bulb

COP—Coefficient of Performance

* Air Conditioning, Heating & Refrigeration Institute.

**At "A" conditions—80°F (26.7°C) indoor db/67°F (19.4°C) indoor wb & 95°F (35°C) outdoor db.

† Rated in accordance with U.S. Government DOE Department of Energy) test procedures and/or AHRI Standards 210/240.

Notes:

1. Ratings are net values, reflecting the effects of circulating fan heat.

Ratings are based on:

Cooling Standard: 80°F (26.7°C) db, 67°F wb (19.4°C) indoor entering—air temperature and 95°F db (35°C) outdoor entering—air temperature.

2. Before purchasing this appliance, read important energy cost and efficiency information available from your retailer.

48ES--A

Gas Heating Capacities and Efficiencies

UNIT 48ES-A	HEATING INPUT (Btuh)	OUTPUT CAPACITY (Btuh)	TEMPERATURE RISE RANGE °F (°C)	AFUE (%)
24040 30040	40,000	32,000	30-60 (16.7-33.3)	80.0
24060 30060 36060 42060	60,000	48,000 48,000 48,000 47,000	25-55 (13.9-30.6)	80.0 80.0 80.0 78.5
36090 42090 48090 60090	90,000	72,000 73,000 73,000 73,000	35-65 (19.4-36.1)	79.3 80.4 80.4 80.4
48115 60115	115,000	93,000	30-60 (16.7-33.3)	80.3
48130 60130	130,000	103,000	35-65 (19.4-36.1)	78.9

LEGEND

AFUE—Annual Fuel Utilization Efficiency

NOTE: Before purchasing this appliance, read important energy cost and efficiency information available from your retailer.

A-Weighted Sound Power Level (dBA)

UNIT 48ES-A	STANDARD RATING dBA	TYPICAL OCTAVE BAND SPECTRUM (dBA without tone adjustment)						
		125	250	500	1000	2000	4000	8000
24---30	76	66.0	66.0	70.5	71.5	67.5	62.5	58.5
30---30/50	75	66.0	63.5	68.0	68.5	67.5	61.5	55.0
36---30/50/60	75	64.0	63.5	68.0	70.5	64.5	61.0	61.0
42---30/50/60	77	67.0	67.0	69.5	70.5	68.0	65.5	61.0
48---30/50/60	78	71.5	66.5	73.0	71.5	68.0	64.0	57.0
60---30/50/60	78	74.5	66.5	70.0	70.0	66.5	64.0	57.0

* Tested in accordance with AHRI Standard 270 (not listed in AHRI).

PHYSICAL DATA

UNIT SIZE	24040	24060	30040	30060	36060	36090	42060	42090
NOMINAL COOLING CAPACITY (ton)	2	2	2-1/2	2-1/2	3	3	3-1/2	3-1/2
NOMINAL HEATING INPUT (Btu/hr)	40,000	60,000	40,000	60,000	60,000	90,000	60,000	90,000
SHIPPING WEIGHT** lb.	311	311	316	316	326	326	420	420
SHIPPING WEIGHT** (kg)	141	141	143	143	148	148	191	191
COMPRESSORS	Scroll							
Quantity	1							
REFRIGERANT (R-410A)								
Quantity lb.	4.8	4.8	6.2	6.2	6.4	6.4	6.1	6.1
Quantity (kg)	2.2	2.2	2.8	2.8	2.9	2.9	2.7	2.7
REFRIGERANT METERING DEVICE	TXV							
OUTDOOR COIL								
Rows...Fins/in.	1...21	1...21	1...21	1...21	1...21	1...21	1...21	1...21
Face Area (sq ft)	10.2	10.2	11.9	11.9	15.4	15.4	13.6	13.6
OUTDOOR FAN								
Nominal CFM	2800	2800	3000	3000	3200	3200	3600	3600
Diameter in.	24	24	24	24	24	24	26	26
Diameter (mm)	609.6	609.6	609.6	609.6	609.6	609.6	660.4	660.4
Motor Hp (Rpm)	1/5 (810)	1/5 (810)	1/5 (810)	1/5 (810)	1/5 (810)	1/5 (810)	1/5 (810)	1/5 (810)
INDOOR COIL								
Rows...Fins/in.	2...17	2...17	3...17	3...17	3...17	3...17	3...17	3...17
Face Area (sq ft)	3.7	3.7	3.7	3.7	3.7	3.7	4.7	4.7
INDOOR BLOWER								
Nominal Cooling Airflow (Cfm)	800	800	1000	1000	1200	1200	1400	1400
Size in.	10x10	10x10	10x10	10x10	11x10	11x10	11x10	11x10
Size (mm.)	254x254	254x254	254x254	254x254	279.4x254	279.4x254	279.4x254	279.4x254
Motor HP (RPM)	1/2 (1050)	1/2 (1050)	1/2 (1050)	1/2 (1050)	3/4 (1000)	3/4 (1000)	3/4 (1075)	3/4 (1075)
FURNACE SECTION*								
Burner Orifice No. (Qty...Drill Size)								
Natural Gas Factory Installed	2...44	2...38	2...44	2...38	2...38	3...38	2...38	3...38
Propane Gas	2...55	2...53	2...55	2...53	2...53	3...53	2...53	3...53
HIGH-PRESSURE SWITCH (psig) Cut-out Reset (Auto)	650 +/- 15 420 +/- 25							
LOSS-OF-CHARGE / LOW-PRESSURE SWITCH (Liquid Line) (psig) cut-out Reset (auto)	20 +/- 5 45 +/- 10							
RETURN-AIR FILTERS††								
Throwaway Size in. (mm)	20x20x1 508x508x25	20x24x1 508x610x25			24x30x1 610x762x25			

48ES--A

PHYSICAL DATA (CONT)

UNIT SIZE	48090	48115	48130	60090	60115	60130
NOMINAL CAPACITY (ton)	4	4	4	5	5	5
NOMINAL HEATING INPUT (Btu/hr)	90,000	115,000	130,000	90,000	115,000	130,000
SHIPPING WEIGHT** lb	428	428	428	450	450	450
SHIPPING WEIGHT** kg	194	194	194	204	204	204
COMPRESSORS	Scroll					
Quantity	1					
REFRIGERANT (R-410A)						
Quantity lb	6.4	6.4	6.4	10.0	10.0	10.0
Quantity (kg.)	2.9	2.9	2.9	4.5	4.5	4.5
REFRIGERANT METERING DEVICE	TXV					
OUTDOOR COIL						
Rows...Fins/in.	1...21	1...21	1...21	2...21	2...21	2...21
Face Area (sq ft)	15.5	15.5	15.5	15.5	15.5	15.5
OUTDOOR FAN						
Nominal Cfm	4000	4000	4000	3200	3200	3200
Diameter in.	26	26	26	26	26	26
Diameter (mm)	660.4	660.4	660.4	660.4	660.4	660.4
Motor Hp (Rpm)	1/5 (810)	1/5 (810)	1/5 (810)	1/5 (810)	1/5 (810)	1/5 (810)
INDOOR COIL						
Rows...Fins/in.	3...17	3...17	3...17	3...17	3...17	3...17
Face Area (sq ft)	4.7	4.7	4.7	5.7	5.7	5.7
INDOOR BLOWER						
Nominal Cooling Airflow (Cfm)	1600	1600	1600	1750	1750	1750
Size in.	11x10	11x10	11x10	11x10	11x10	11x10
Size (mm)	279.4x254	279.4x254	279.4x254	279.4x254	279.4x254	279.4x254
Motor HP (RPM)	1.0 (1075)	1.0 (1075)	1.0 (1075)	1.0 (1040)	1.0 (1040)	1.0 (1040)
FURNACE SECTION*						
Burner Orifice No.						
Natural Gas Qty...Drill Size (Factory Installed)	3...38	3...33	3...31	3...38	3...33	3...31
Propane Gas	3...53	3...51	3...49	3...53	3...51	3...49
HIGH-PRESSURE SWITCH (psig) Cut-out Reset (Auto)	650 +/- 15 420 +/- 25					
LOSS-OF-CHARGE / LOW-PRESSURE SWITCH (Liquid Line) (psig) cut-out Reset (auto)	20 +/- 5 45 +/- 10					
RETURN-AIR FILTERS Throwaway†‡ in. (mm)	24x36x1 610x914x25					

*Based on altitude of 0 to 2000 ft (0-610 m).

† Required filter sizes shown are based on the larger of the AHRI (Air Conditioning, Heating and Refrigeration Institute) rated cooling airflow or the heating airflow velocity of 300 ft/minute for throwaway type. Air filter pressure drop for non-standard filters must not exceed 0.08 IN. W.C.

‡ If using accessory filter rack refer to the filter rack installation instructions for correct filter sizes and quantity.

** For 460 volt units, add 14 lbs (6.35 kg) to the shipping weight.

48ES--A

OPTIONS AND ACCESSORIES

ITEM	DESCRIPTION	FACTORY INSTALLED OPTION	FIELD INSTALLED ACCESSORY
Coil Options	Base unit with tin plated indoor coil hairpins	X	
Compressor Start Kit	Compressor Start Kit assists compressor start-up by providing additional starting torque on sing phase units only.		X
Corporate Thermostats	Thermostats provide control for the system heating and cooling functions.		X
Crankcase Heater	Crankcase Heater provides anit-floodback protection for low-load cooling applications.		X*
Economizer	Horizontal Economizer with solid state controls and barometric relief dampers includes filter racks and provide outdoor air during cooling and reduce compressor operation.		X
	Vertical Economizer with solid state controls and barometric relief dampers includes filter racks and provide outdoor air during cooling and reduce compressor operation.	X	X
Filter Rack	Filter Rack features easy installation, serviceability, and high-filtering performance for vertical applications. Includes 1-in. filter.	X	X
Flat Roof Curbs	Flat Roof Curbs in both 11-in (279 mm) and 14-in. (356 mm) sizes are available for roof mounted applications.		X
Flue Discharge Deflector	Directs flue gas exhaust 90 degrees upward from current discharge.		X
Heat Exchanger	Stainless Steel Heat Exchanger	X	
High Altitude Propane Conversion Kit	High Altitude Propane Conversion Kit is for use at 2001 to 6000 ft. (611 – 1829 m) above sea level. Kit consists of propane gas orifices that compensate for gas heat operation at high altitude.		X
Low Ambient Kit	Low Ambient Kit (Motormaster II Control) allows the use of mechanical cooling down to outdoor temperatures as low as 0° F (– 18° C) when properly installed.		X
Louver Metal Outdoor Coil Grilles	Louver Metal Outdoor Coil Grilles provides hail and vandalism protection.		
Manual Outside Air Damper	Manual Outside Air Damper includes hood and filter rack with adjustable damper blade for up to 25% outdoor air.		X
Natural to Propane Gas Conversion Kit	Natural to Propane Gas Conversion Kit allows for conversion from natural gas to propane gas (0–2000 ft) (0–610 m)		X
Propane to Natural Gas Conversion Kit	Propane to Natural Gas Conversion Kit allows for conversion from propane to natural gas for altitudes of 0–2000 ft (0–610 m)		X
Square-to-Round Duct Transition Kit	Square-to-Round Duct Transition Kit enable 24–48 size units to be fitted to 14 in. (356 mm) round ductwork.		X
Time Guard II	Automatically prevents the compressor from restarting for at least 4 minutes and 45 seconds after shutdown of the compressor. Not required when a corporate programmable thermostat is applied or with a RTU-MP control.		X

*Refer to Price Page for application detail.

ECONOMIZER

48ES--A

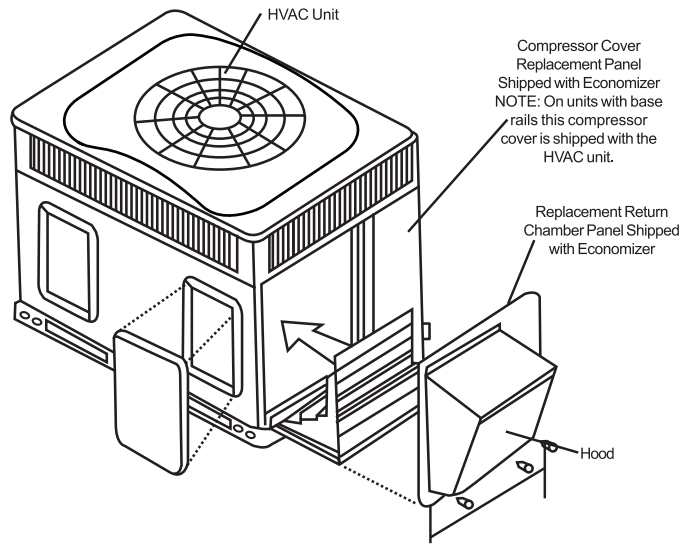
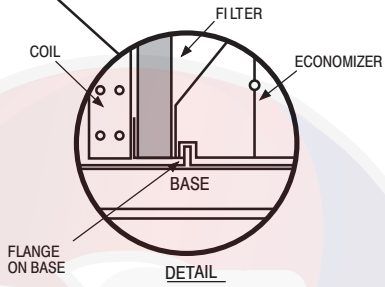
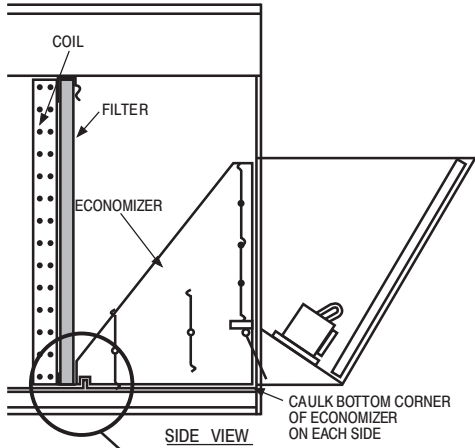

Vertical Economizer

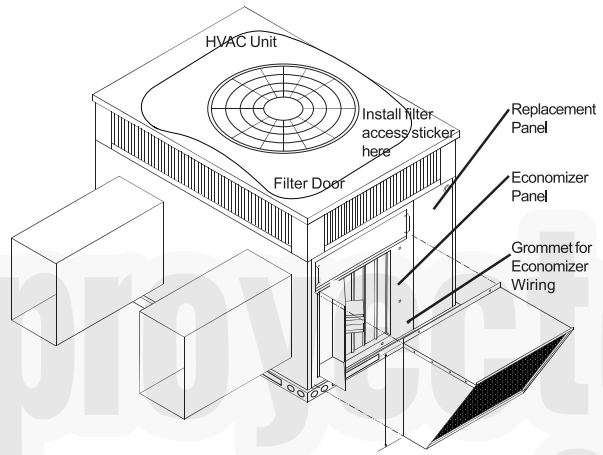

Horizontal Economizer

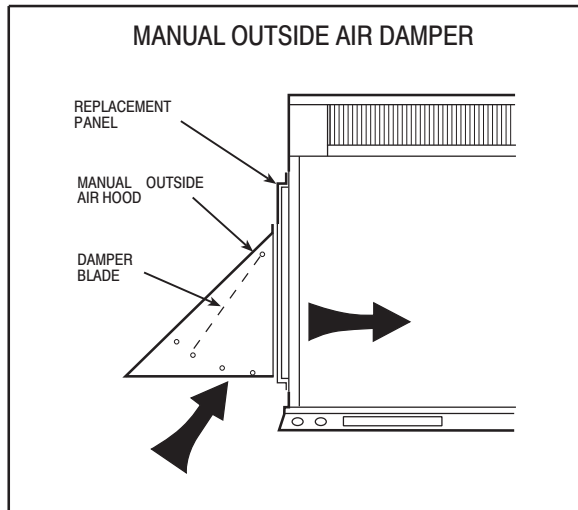
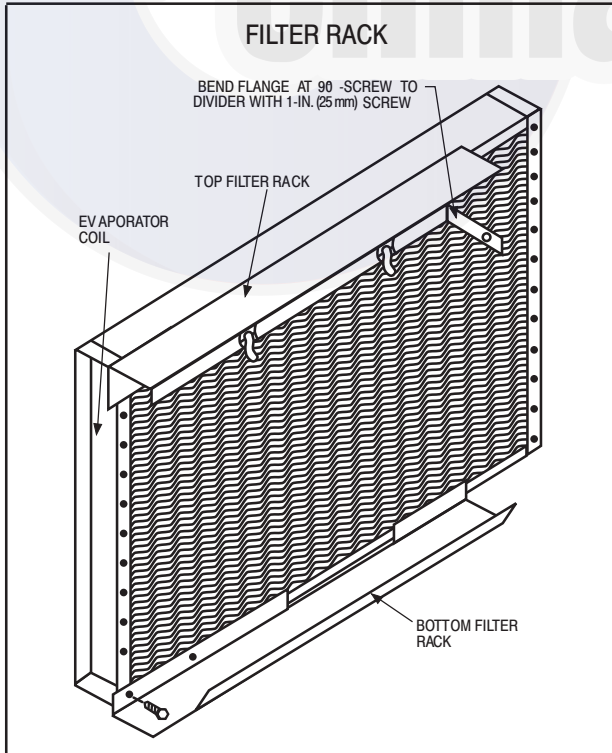

A09375

UNIT DIMENSIONS - 48ES-A24-36

UNIT	ELECTRICAL CHARACTERISTICS	UNIT WT.		UNIT HEIGHT		CENTER OF GRAVITY					
		LB	KG	"A"	"A"	X	Y	Z			
48ES(-)/NA24(040/060)130	208/230-1-50	304	137.8	40-1/8	1019	22-13/16	519.4	15-5/16	388.9	15-11/16	388.5
48ES(-)/NA30(040/060)137.5	208/230-1-1	309	140.0	42-1/8	1010	22-13/16	519.4	15-5/16	388.9	15-13/16	401.8
48ES(-)/NA36(060/090)150	208/230-1-1	319	144.6	46-1/8	1172	22-13/16	519.4	15-5/16	388.9	16-5/8	422.3
48ES(-)/NA36(060/090)160	460-3-60	333	150.9	46-1/8	1172	22-13/16	519.4	15-5/16	388.9	16-5/8	422.3

UNITS	VOLTAGE	CORNER WEIGHT		
		LB/16	"3"	"4"
48ES(-)/NA24(040/060)130	208/230	45.6	20.7	16.0
48ES(-)/NA30(040/060)137.5	208/230	46.3	21.0	16.1
48ES(-)/NA36(060/090)150	208/230	47.8	22.1	17.3
48ES(-)/NA36(060/090)160	460	47.8	22.1	17.3

	INCHES (MM)
TOP OF UNIT	2 (50.8)
DUCT SIDE OF UNIT	2 (50.8)
SIDE OPPOSITE DUCTS	14 (355.6)
BOTTOM OF UNIT	0 (0.0)
FLUE PANEL	36 (914.4)

REQ. REQUIRED CLEARANCES

	INCHES (MM)
BETWEEN UNITS, POWER ENTRY SIDE	42 (1066.8)
UNIT AND BLOWER OR CONCRETE WALLS AND OTHER	36 (914.4)
ROUNDED SURFACES, POWER ENTRY SIDE	42 (1066.8)
EVAP. COIL ACCESS SIDE	36 (914.4)
POWER ENTRY SIDE	42 (1066.8)
(EXCEPT FOR REC REQUIREMENTS)	48 (1219.2)
SIDE OPPOSITE DUCTS	48 (1219.2)
DUCT PANEL	32 (812.8)

*MINIMUM DISTANCES: IF UNIT IS PLACED LESS THAN 12 (304.8) FROM WALL SYSTEM, THEN SYSTEM PERFORMANCE MAYBE COMPROMISED.

DIMENSIONS IN [] ARE IN MM

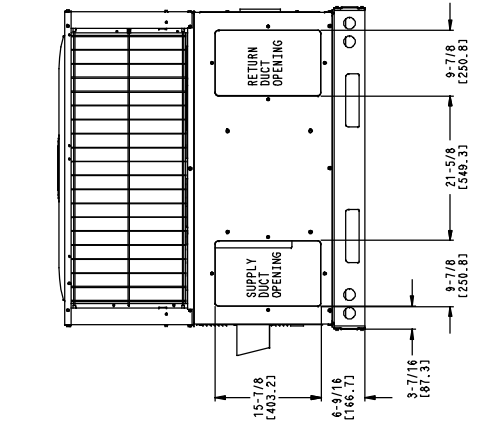
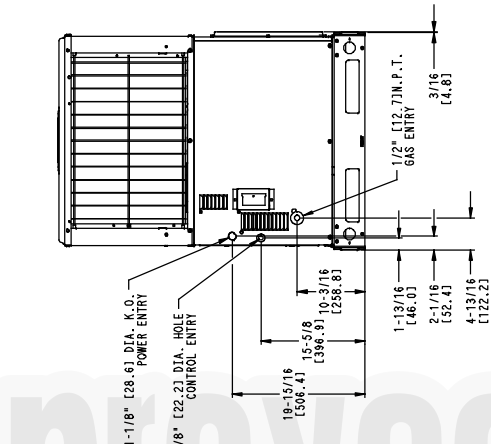
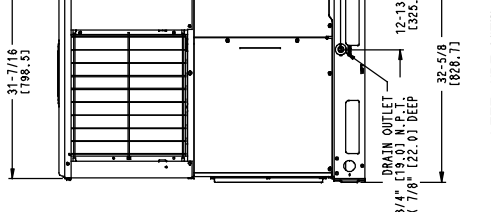
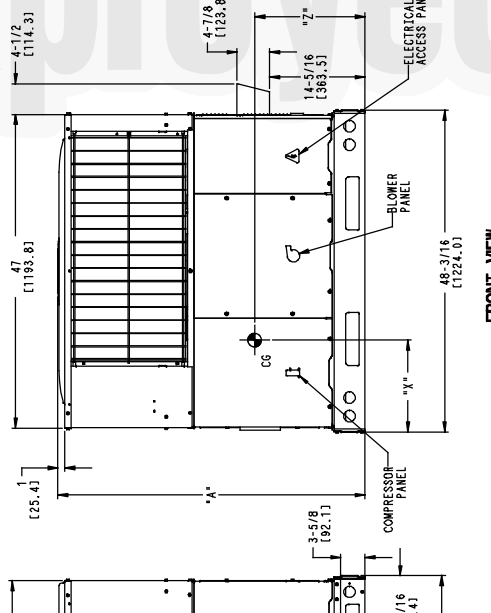
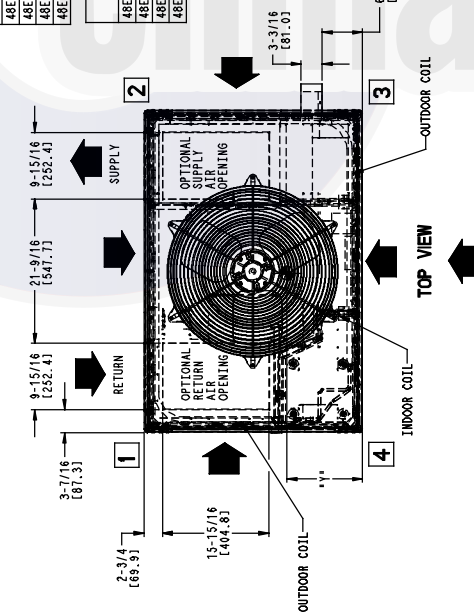

48ES500214
REV 3.0

48ES--A

UNIT DIMENSIONS - 48ES-A42-60

48ES--A

UNIT	ELECTRICAL CHARACTERISTICS	UNIT WT.			UNIT HEIGHT IN/MM			CENTER OF GRAVITY IN/MM			
		LB	KG	"A"	"A"	X	Y	Z			
48ES(-)N/A42(060/090)(3/5)0	208/230-1, 208/230-3-60	411	186.5	44-3/4	1137	22-13/16	579.4	18	457.2	17-1/8	435.0
48ES(-)N/A42(060/090)60	460-3-60	425	192.9	44-3/4	1137	22-13/16	579.4	18	457.2	17-1/8	435.0
48ES(-)N/A48(090/115/130)(3/5)0	208/230-1, 208/230-3-60	419	190.2	46-3/4	1187	22-13/16	579.4	18	457.2	17-3/8	441.3
48ES(-)N/A48(090/115/130)60	460-3-60	433	196.5	46-3/4	1187	22-13/16	579.4	18	457.2	17-3/8	441.3
48ES(-)N/A60(090/115/130)(3/5)0	208/230-1, 208/230-3-60	441	200.1	46-3/4	1187	22-13/16	579.4	18	457.2	17-5/8	441.7
48ES(-)N/A60(090/115/130)60	460-3-60	455	206.5	46-3/4	1187	22-13/16	579.4	18	457.2	17-5/8	441.7

UNITS	VOLTAGE	CORNER WEIGHT LB/KG			
		"1"	"2"	"3"	"4"
48ES(-)N/A42(060/090)(3/5)0	208/230	61.7	28.0	82.2	37.3
48ES(-)N/A42(060/090)60	460	61.7	28.0	82.2	37.3
48ES(-)N/A48(090/115/130)(3/5)0	208/230	62.9	28.4	83.8	38.1
48ES(-)N/A48(090/115/130)60	460	62.9	28.4	83.8	38.1
48ES(-)N/A60(090/115/130)(3/5)0	208/230	66.2	30.0	88.2	40.1
48ES(-)N/A60(090/115/130)60	460	66.2	30.0	88.2	40.1

REQUIRED CLEARANCES TO COMBUSTIBLE MATL.

	INCHES (MM)
TOP OF UNIT.....	14 (355.6)
SIDE OF UNIT.....	2 (50.8)
SIDE OPPOSITE DUCTS.....	14 (355.6)
BOTTOM OF UNIT.....	3 (76.2)
FLOOR PANEL.....	36 (914.4)

NEC. REQUIRED CLEARANCES

	INCHES (MM)
BETWEEN UNITS, POWER ENTRY SIDE.....	42 (1066.8)
UNIT AND UNGROUND SURFACES, POWER ENTRY SIDE.....	36 (914.4)
UNIT AND BLOCK OR CONCRETE WALLS AND OTHER GROUND SURFACES, POWER ENTRY SIDE.....	42 (1066.8)

REQUIRED CLEARANCE FOR OPERATION AND SERVICING

	INCHES (MM)
EVAP. COIL ACCESS SIDE.....	36 (914.4)
POWER ENTRY SIDE.....	42 (1066.8)
UNITS EXCEPT NEC REQUIREMENTS.....	48 (1219.2)
UNIT TOP.....	36 (914.4)
SIDE OPPOSITE DUCTS.....	48 (1219.2)
DUCT PANEL.....	12 (304.8)*

*MINIMUM DISTANCES IF UNIT IS PLACED LESS THAN 12 (304.8) FROM WALL SYSTEM, THEN SYSTEM PERFORMANCE MAY BE COMPROMISED. DIMENSIONS IN () ARE IN MM.

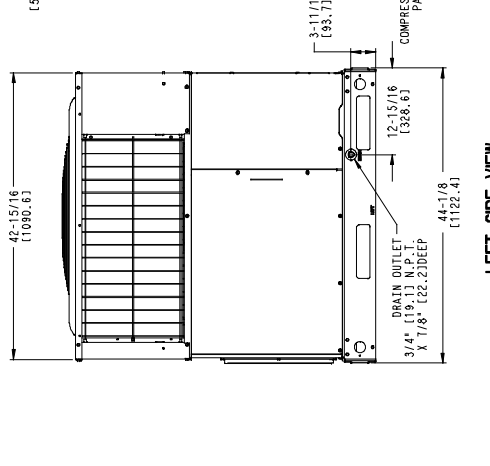
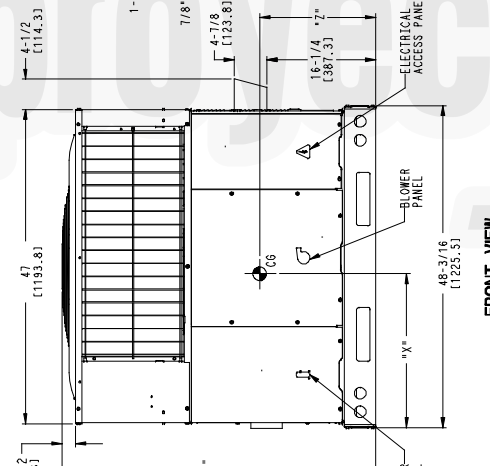
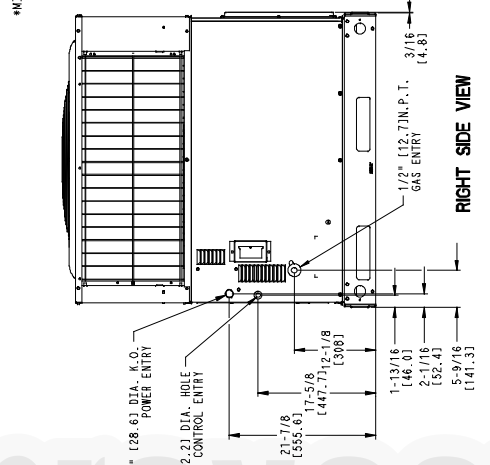
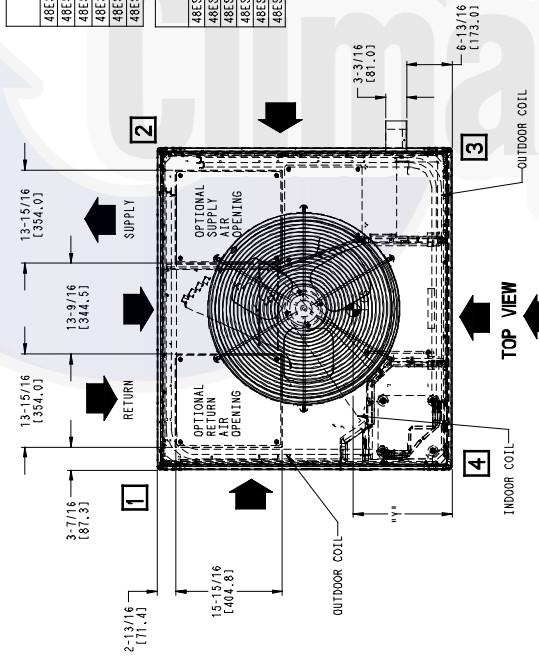

48ES500215 REV 3.0

ACCESSORY DIMENSIONS

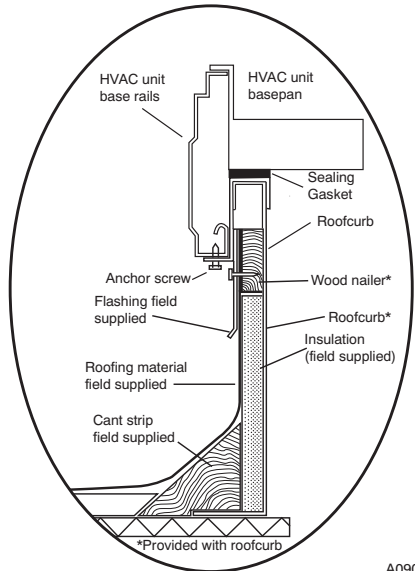

A09090

ROOF CURB DETAIL

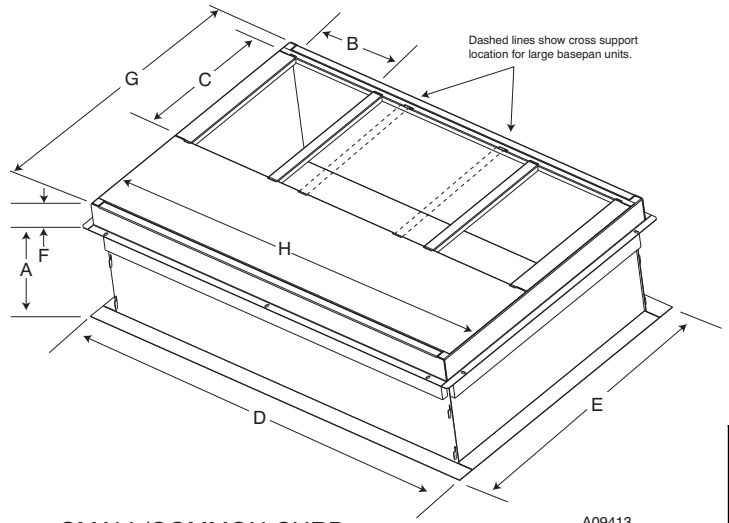

SMALL/COMMON CURB

A09413

48ES--A

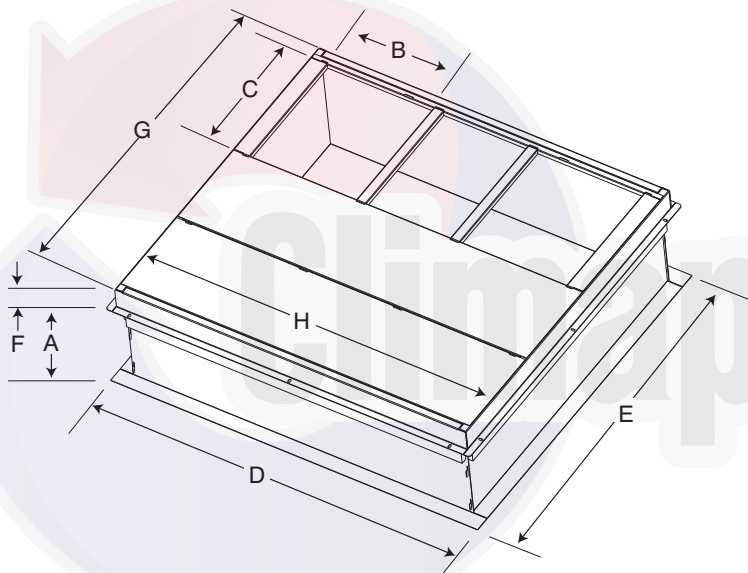

LARGE CURB

A09415

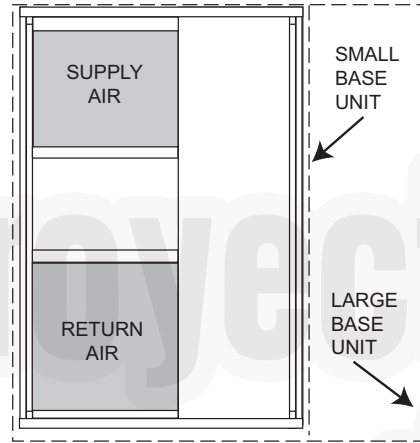

UNIT PLACEMENT ON COMMON CURB

A09094

SMALL OR LARGE BASE UNIT

A09414

UNIT SIZE	CATALOG NUMBER	A IN. (mm)	B (small / common base) IN. (mm)*	B (large base) IN. (mm)*	C IN. (mm)	D IN. (mm)	E IN. (mm)	F IN. (mm)	G IN. (mm)	H IN. (mm)
Small or Large	CPRFCURB010A00	11 (279)	10 (254)	14 (356)	16 (406)	47.8 (1214)	32.4 (822)	2.7 (69)	30.6 (778)	46.1 (1170)
	CPRFCURB011A00	14 (356)					43.9 (1116)			
Large	CPRFCURB012A00	11 (279)	14 (356)	14 (356)	16 (406)	47.8 (1214)	43.9 (1116)	2.7 (69)	42.2 (1072)	46.1 (1170)
	CPRFCURB013A00	14 (356)					43.9 (1116)			

* Part Numbers CPRFCURB010A00 and CPRFCURB011A00 can be used on both small and large basepan units. The cross supports must be located based on whether the unit is a small basepan or a large basepan.

NOTES:

1. Roof curb must be set up for unit being installed.
2. Seal strip must be applied, as required, to unit being installed.
3. Roof curb is made of 16-gauge steel.
4. Attach ductwork to curb (flanges of duct rest on curb).
5. Insulated panels: 1-in. (25.4 mm) thick fiberglass 1 lb. density.

SELECTION PROCEDURE (WITH EXAMPLE)

1. Determine cooling and heating requirements at design conditions:

Given:

Required Cooling Capacity (TC) 34,000 Btuh
Sensible Heat Capacity (SHC) 25,000 Btuh
Required Heating Capacity 60,000 Btuh
Condenser Entering Air Temperature 95°F (35°C)
Indoor-Air Temperature 80°F (26°C)edb 67°F (19°C) ewb
Evaporator Air Quantity 1200 CFM
External Static Pressure 0.300 in. W.C.
Electrical Characteristics 230-1-60

2. Select unit based on required cooling capacity.

Enter Net Cooling Capacities table at condenser entering temperature of 95°F (35°C). Unit 036 at 1200 CFM and 67°F (19°C) ewb (entering wet bulb) will provide a total capacity of 34,400 Btuh and a SHC of 25,900 Btuh. Calculate SHC correction, if required, using Note 4 under Cooling Capacities tables.

3. Select heating capacity of unit to provide design condition requirement.

In the Heating Capacities and Efficiencies table, note that the unit 036090 will provide 72,000 Btuh with an input of 90,000 Btuh.

4. Determine fan speed and power requirements at design conditions.

Before entering the air delivery tables, calculate the total static pressure required. From the given example, the Wet Coil Pressure Drop Table, and the Filter Pressure Drop Table:

External Static Pressure	0.300 in. W.C.
Filter	0.130 in. W.C.
Wet Coil Pressure Drop	<u>0.100 in. W.C</u>
Total Static Pressure	0.530 in. W.C

Enter the table for Dry Coil Air Delivery—Horizontal and Downflow Discharge. At .530 in. W.C. ESP, the closest speed to 1200 CFM is Med-High (orange wire), which delivers 1316 CFM at .6 in ESP.

5. Select unit that corresponds to power source available.

The Electrical Data Table shows that the unit is designed to operate at 230-1-60.

48ES--A

Climaproyectos
.com

PERFORMANCE DATA

48ES-A24

EVAPORATOR AIR		CONDENSER ENTERING AIR TEMPERATURES °F (°C)																	
		75 (23.9)			85 (29.4)			95 (35)			105 (40.6)			115 (46.1)			125 (51.7)		
CFM/BF	EWB °F (°C)	Capacity MBtuh		Total Sys KW	Capacity MBtuh		Total Sys KW	Capacity MBtuh		Total Sys KW	Capacity MBtuh		Total Sys KW	Capacity MBtuh		Total Sys KW			
		Total	Sens		Total	Sens		Total	Sens		Total	Sens		Total	Sens				
700/0.07	57 (13.8)	22.74	22.74	1.66	21.26	21.26	1.85	19.77	19.77	2.06	18.28	18.28	2.29	16.77	16.77	2.54	15.24	15.24	2.80
	62 (16.6)	23.94	20.55	1.66	22.18	19.57	1.86	20.42	18.59	2.07	18.67	17.59	2.30	16.93	16.57	2.54	15.24	15.24	2.80
	63* (17.2)	24.48	17.00	1.67	22.68	16.12	1.86	20.88	15.23	2.07	19.08	14.35	2.30	17.27	13.46	2.54	15.45	12.56	2.81
	67 (19.4)	26.34	17.55	1.67	24.42	16.65	1.86	22.49	15.76	2.07	20.57	14.86	2.30	18.64	13.97	2.55	16.70	13.07	2.82
	72 (22.2)	28.95	14.51	1.67	26.85	13.70	1.87	24.76	12.88	2.08	22.66	12.07	2.31	20.56	11.25	2.56	18.45	10.43	2.83
	57 (13.8)	23.78	23.78	1.68	22.21	22.21	1.87	20.64	20.64	2.08	19.06	19.06	2.31	17.46	17.46	2.56	15.85	15.85	2.82
	62 (16.6)	24.57	22.03	1.68	22.75	20.99	1.87	20.94	19.93	2.08	19.15	18.83	2.31	17.46	17.46	2.56	15.85	15.85	2.82
	63* (17.2)	25.10	18.06	1.68	23.23	17.14	1.88	21.36	16.21	2.09	19.49	15.29	2.32	17.62	14.37	2.56	15.74	13.44	2.82
	67 (19.4)	27.00	18.66	1.69	25.00	17.73	1.88	23.00	16.80	2.09	21.01	15.87	2.32	19.01	14.94	2.57	17.00	14.00	2.83
	72 (22.2)	29.65	15.23	1.69	27.48	14.39	1.89	25.30	13.54	2.10	23.13	12.71	2.33	20.96	11.86	2.58	18.77	11.01	2.84
900/0.1	57 (13.8)	24.67	24.67	1.70	23.02	23.02	1.89	21.37	21.37	2.10	19.71	19.71	2.33	18.05	18.05	2.58	16.36	16.36	2.84
	62 (16.6)	25.09	23.40	1.70	23.23	22.27	1.89	21.39	21.39	2.10	19.71	19.71	2.33	18.04	18.04	2.58	16.35	16.35	2.84
	63* (17.2)	25.60	19.06	1.70	23.66	18.11	1.89	21.74	17.15	2.10	19.81	16.20	2.33	17.89	15.24	2.58	15.96	14.27	2.84
	67 (19.4)	27.52	19.73	1.70	25.45	18.76	1.90	23.40	17.80	2.11	21.34	16.83	2.34	19.29	15.87	2.59	17.23	14.89	2.85
	72 (22.2)	30.21	15.91	1.71	27.97	15.04	1.90	25.72	14.18	2.11	23.50	13.31	2.35	21.26	12.45	2.60	19.02	11.58	2.86

See Legend and Notes on Page 19.

PERFORMANCE DATA
48ES-A30

EVAPORATOR AIR		CONDENSER ENTERING AIR TEMPERATURES °F (°C)																	
		75 (23.9)			85 (29.4)			95 (35)			105 (40.6)			115 (46.1)			125 (51.7)		
		EWB °F (°C)	CFM/BF	Capacity MBtuh	Total Sys KW	Capacity MBtuh	Total Sys KW	Capacity MBtuh	Total Sys KW	Capacity MBtuh	Total Sys KW	Capacity MBtuh	Total Sys KW	Capacity MBtuh	Total Sys KW	Capacity MBtuh	Total Sys KW		
57 (13.6)		29.20	2.09	27.20	2.30	25.19	2.52	23.18	2.77	21.16	3.04	19.13	3.32						
62 (16.6)		30.09	2.09	27.78	2.30	25.48	2.52	23.12	2.77	21.16	3.04	19.12	3.32						
63* (17.2)	875/0.03	30.75	2.09	28.36	2.30	25.99	2.52	23.63	2.77	21.26	3.04	18.90	3.32						
67 (19.4)		33.12	2.08	30.58	2.29	28.05	2.52	19.23	2.77	23.00	3.04	20.48	3.32						
72 (22.2)		36.50	2.08	33.73	2.29	30.97	2.52	28.22	2.77	25.48	3.04	22.73	3.32						
57 (13.6)		30.51	2.12	28.39	2.33	26.27	2.56	24.14	2.80	22.01	3.07	19.87	3.35						
62 (16.6)		30.85	2.12	28.49	2.33	26.26	2.56	24.14	2.80	22.01	3.07	19.86	3.35						
63* (17.2)	1000/0.03	31.44	2.12	28.97	2.33	26.51	2.56	24.07	2.81	21.63	3.07	19.21	3.35						
67 (19.4)		33.86	2.12	31.22	2.33	28.60	2.55	25.99	2.80	23.40	3.07	20.80	3.35						
72 (22.2)		37.30	2.11	34.43	2.32	31.58	2.55	28.74	2.80	25.91	3.07	23.07	3.35						
57 (13.6)		31.61	2.15	29.39	2.36	27.17	2.59	24.95	2.84	22.72	3.10	20.48	3.39						
62 (16.6)		31.61	2.15	29.39	2.36	27.17	2.59	24.95	2.84	22.72	3.10	20.48	3.39						
63* (17.2)	1125/0.04	31.97	2.15	29.43	2.36	26.91	2.59	24.41	2.84	21.92	3.10	19.45	3.39						
67 (19.4)		34.42	2.15	31.71	2.36	29.02	2.59	26.35	2.84	23.69	3.10	21.05	3.39						
72 (22.2)		37.91	2.14	34.96	2.35	32.03	2.58	29.12	2.83	26.22	3.10	23.32	3.39						

See Legend and Notes on Page 19.

PERFORMANCE DATA (CONT)

48ES-A36

EVAPORATOR AIR CFM/BF	EWB °F (°C)	CONDENSER ENTERING AIR TEMPERATURES °F (°C)																	
		75 (23.9)			85 (29.4)			95 (35)			105 (40.6)			115 (46.1)			125 (51.7)		
		Capacity MBtuh Total	Sens	Total S/S KW	Capacity MBtuh Total	Sens	Total S/S KW	Capacity MBtuh Total	Sens	Total S/S KW	Capacity MBtuh Total	Sens	Total S/S KW	Capacity MBtuh Total	Sens	Total S/S KW			
1050/0.04	57 (13.6)	35.66	35.66	2.38	32.84	32.84	2.71	30.06	30.06	3.07	27.32	27.32	3.47	24.62	24.62	3.91	21.93	21.93	4.39
	62 (16.6)	37.06	32.25	2.39	33.82	30.46	2.71	30.65	28.68	3.07	27.56	26.88	3.47	24.62	24.62	3.91	21.93	21.93	4.39
	63* (17.2)	37.87	26.52	2.39	34.55	24.93	2.71	31.28	23.37	3.08	28.09	21.82	3.48	24.95	20.29	3.91	18.77	18.77	4.39
	67 (19.4)	40.79	27.41	2.39	37.23	25.80	2.72	33.74	24.21	3.08	30.32	22.64	3.48	26.96	21.09	3.92	19.54	19.54	4.39
	72 (22.2)	44.91	22.49	2.39	41.02	21.04	2.72	37.19	19.62	3.09	33.45	18.21	3.49	29.78	16.82	3.93	15.44	15.44	4.40
	57 (13.6)	37.24	37.24	2.43	34.27	34.27	2.76	31.33	31.33	3.12	28.44	28.44	3.52	25.58	25.58	3.96	22.76	22.76	4.44
1200/0.04	62 (16.6)	37.97	34.65	2.43	34.64	32.72	2.76	31.35	31.35	3.12	28.43	28.43	3.52	25.58	25.58	3.96	22.75	22.75	4.44
	63* (17.2)	38.73	28.25	2.43	35.29	26.59	2.76	31.91	24.95	3.12	28.60	23.33	3.52	25.37	21.73	3.96	20.12	20.12	4.44
	67 (19.4)	41.71	29.24	2.44	38.02	27.56	2.76	34.40	25.90	3.13	30.86	24.26	3.53	27.40	22.63	3.97	21.00	21.00	4.44
	72 (22.2)	45.90	23.65	2.44	41.86	22.16	2.77	37.91	20.68	3.13	34.05	19.23	3.54	30.26	17.79	3.98	16.36	16.36	4.45
	57 (13.6)	38.59	38.59	2.48	35.47	35.47	2.81	32.40	32.40	3.17	29.37	29.37	3.57	26.39	26.39	4.01	23.43	23.43	4.49
	62 (16.6)	38.77	36.79	2.48	35.46	35.46	2.81	32.39	32.39	3.17	29.37	29.37	3.57	26.38	26.38	4.01	23.43	23.43	4.49
1350/0.05	63* (17.2)	39.40	29.91	2.48	35.85	28.18	2.81	32.38	26.47	3.17	28.99	24.78	3.57	25.69	23.09	4.01	22.46	21.40	4.49
	67 (19.4)	42.41	31.01	2.48	38.61	29.26	2.81	34.89	27.52	3.18	31.27	25.81	3.58	27.72	24.10	4.02	24.26	22.39	4.49
	72 (22.2)	46.65	24.77	2.49	42.51	23.22	2.82	38.45	21.70	3.18	34.49	20.20	3.58	30.61	18.72	4.03	26.80	17.24	4.50

See Legend and Notes on Page 19.

PERFORMANCE DATA

48ES-A42

EVAPORATOR AIR		CONDENSER ENTERING AIR TEMPERATURES °F (°C)																	
		75 (23.9)			85 (29.4)			95 (35)			105 (40.6)			115 (46.1)			125 (51.7)		
CFM/BF	EWB	Capacity MBtuh		Total Sys KW	Capacity MBtuh		Total Sys KW	Capacity MBtuh		Total Sys KW	Capacity MBtuh		Total Sys KW	Capacity MBtuh		Total Sys KW			
		Total	Sens		Total	Sens		Total	Sens		Total	Sens		Total	Sens				
1225/0.03	57 (13.8)	40.45	40.45	3.00	37.98	37.98	3.37	35.49	35.49	3.78	32.98	32.98	4.20	30.44	30.44	4.65	27.84	27.84	5.10
	62 (16.6)	42.06	37.63	2.94	35.73	35.73	3.33	33.83	33.83	3.74	31.92	31.92	4.18	30.48	30.48	4.64	27.88	27.88	5.10
	63* (17.2)	42.93	30.96	2.91	29.27	39.95	3.31	36.96	27.59	3.72	33.97	25.92	4.17	30.95	30.95	4.63	27.90	22.59	5.10
	67 (19.4)	46.12	31.94	2.80	30.23	42.92	3.19	39.72	28.52	3.61	36.53	26.83	4.05	33.31	33.31	4.52	30.04	23.46	4.99
	72 (22.2)	50.58	26.16	2.65	24.61	47.09	3.04	43.59	23.08	3.46	40.11	21.56	3.90	36.60	36.60	4.37	33.04	18.53	4.84
	57 (13.8)	42.24	42.24	2.98	39.61	39.61	3.35	36.97	36.97	3.76	34.32	34.32	4.18	31.63	31.63	4.63	28.88	28.88	5.08
1400/0.04	62 (16.6)	43.11	40.44	2.95	38.38	40.11	3.34	37.15	36.28	3.75	34.31	34.31	4.18	31.62	31.62	4.63	28.88	28.88	5.08
	63* (17.2)	43.91	32.97	2.92	31.21	40.81	3.32	37.71	29.45	3.73	34.61	27.70	4.18	31.49	31.49	4.64	28.35	24.21	5.12
	67 (19.4)	47.15	34.07	2.81	32.28	43.82	3.20	40.50	30.50	3.62	37.19	28.73	4.06	33.86	33.86	4.53	30.50	25.20	5.00
	72 (22.2)	51.67	27.51	2.65	25.91	48.05	3.05	44.42	24.32	3.46	40.81	22.75	3.91	37.19	37.19	4.38	33.51	19.62	4.85
	57 (13.8)	43.75	49.75	2.97	40.99	40.99	3.34	38.22	38.22	3.75	35.43	35.43	4.17	32.62	32.62	4.62	29.74	29.74	5.07
	62 (16.6)	44.02	42.95	2.96	41.01	41.01	3.34	38.21	38.21	3.75	35.43	35.43	4.17	32.61	32.61	4.62	29.74	29.74	5.07
1575/0.05	63* (17.2)	44.67	34.90	2.94	33.06	41.47	3.33	38.28	31.23	3.75	35.10	29.41	4.20	31.91	31.91	4.66	28.70	25.74	5.14
	67 (19.4)	47.93	36.13	2.82	34.26	44.51	3.21	41.09	32.40	3.63	37.69	30.56	4.08	34.28	34.28	4.54	30.85	26.85	5.02
	72 (22.2)	52.51	28.80	2.67	27.15	48.78	3.06	45.05	25.51	3.48	41.34	23.89	3.93	37.63	37.63	4.39	33.86	20.67	4.87

See Legend and Notes on Page 19.

PERFORMANCE DATA (CONT)

48ES-A48

EVAPORATOR AIR CFMBF	EWB °F (°C)	CONDENSER ENTERING AIR TEMPERATURES °F (°C)												Total Sys KW						
		75 (23.9)			85 (29.4)			95 (35)			105 (40.6)				115 (46.1)			125 (51.7)		
		Capacity MBtuh	Sens	Total Sys KW	Capacity MBtuh	Sens	Total Sys KW	Capacity MBtuh	Sens	Total Sys KW	Capacity MBtuh	Sens	Total Sys KW		Capacity MBtuh	Sens	Total Sys KW			
1400/0.04	57 (13.8)	46.51	48.51	3.29	43.60	43.60	40.66	40.66	4.11	37.70	37.70	4.56	34.70	34.70	5.05	31.64	31.64	5.55		
	62 (16.6)	48.43	41.91	3.29	45.02	40.09	38.24	41.60	4.10	38.19	36.35	4.56	34.81	34.56	5.05	31.64	31.64	5.55		
	63* (17.2)	49.45	34.51	3.29	45.95	32.87	32.87	42.43	4.10	38.89	29.56	4.56	35.34	27.89	5.05	31.75	26.19	5.55		
	67 (19.4)	53.14	35.61	3.29	49.39	33.95	33.95	45.62	4.10	41.85	30.61	4.55	38.05	28.93	5.04	34.20	27.21	5.55		
	72 (22.2)	58.33	29.19	3.28	54.23	27.68	26.15	50.11	4.09	46.00	24.62	4.55	41.85	23.08	5.03	37.64	21.51	5.54		
	57 (13.8)	48.55	48.55	3.35	45.46	45.46	42.35	42.35	4.16	39.21	39.21	4.61	36.04	36.04	5.10	32.81	32.81	5.60		
1600/0.05	62 (16.6)	49.62	44.99	3.35	46.10	43.02	40.97	42.60	4.16	39.21	39.21	4.61	36.04	36.04	5.10	32.80	32.80	5.60		
	63* (17.2)	50.57	36.73	3.35	46.92	35.02	33.30	43.27	4.16	39.61	31.57	4.61	35.94	29.83	5.10	32.24	28.05	5.60		
	67 (19.4)	54.31	37.96	3.34	50.41	36.23	34.50	46.50	4.15	42.59	32.76	4.61	38.66	30.99	5.09	34.70	29.20	5.60		
	72 (22.2)	59.58	30.68	3.34	55.32	29.12	27.54	51.05	4.15	46.80	25.97	4.60	42.51	24.38	5.08	38.17	22.76	5.59		
	57 (13.8)	50.26	50.26	3.40	47.02	47.02	43.76	43.76	4.21	40.47	40.47	4.66	37.15	37.15	5.15	33.76	33.76	5.65		
	62 (16.6)	50.64	47.75	3.40	47.06	47.06	43.75	43.75	4.21	40.46	40.46	4.66	37.14	37.14	5.15	33.76	33.76	5.65		
1800/0.06	63* (17.2)	51.44	38.88	3.40	47.67	37.10	35.31	43.92	4.21	40.16	33.51	4.67	36.40	31.68	5.15	32.62	29.81	5.66		
	67 (19.4)	55.22	40.25	3.40	51.19	38.45	36.64	47.17	4.21	43.16	34.83	4.66	39.13	32.98	5.14	35.08	31.10	5.65		
	72 (22.2)	60.54	32.12	3.40	56.16	30.51	28.89	51.77	4.20	47.40	27.27	4.65	43.00	25.64	5.13	38.55	23.98	5.64		

See Legend and Notes on Page 19.

PERFORMANCE DATA

48ES-A60

EVAPORATOR AIR CFM/BF	EWB °F (°C)	CONDENSER ENTERING AIR TEMPERATURES °F (°C)																	
		75 (23.9)			85 (29.4)			95 (35)			105 (40.6)			115 (46.1)			125 (51.7)		
		Capacity MBtuh	Sens	Total Sys KW	Capacity MBtuh	Sens	Total Sys KW	Capacity MBtuh	Sens	Total Sys KW	Capacity MBtuh	Sens	Total Sys KW	Capacity MBtuh	Sens	Total Sys KW	Capacity MBtuh	Sens	Total Sys KW
1750/0.02	57 (13.8)	57.89	57.89	4.22	54.53	54.53	4.84	51.13	51.13	5.08	47.68	47.68	5.56	44.15	44.15	6.06	40.50	40.50	6.59
	62 (16.6)	59.66	51.98	4.24	55.71	49.84	4.85	47.68	47.68	5.09	45.44	47.84	5.56	44.15	44.15	6.06	40.49	40.49	6.59
	63* (17.2)	60.79	42.58	4.25	56.72	40.64	4.86	38.69	38.69	5.10	36.74	48.53	5.57	44.37	34.78	6.06	40.12	32.78	6.58
	67 (19.4)	65.28	43.94	4.28	60.89	41.97	4.70	40.00	40.00	5.14	38.03	52.08	5.61	47.59	36.03	6.10	43.00	34.00	6.62
	72 (22.2)	71.52	35.78	4.34	66.71	33.95	4.75	32.13	32.13	5.19	30.30	57.02	5.66	52.07	28.45	6.15	47.01	26.57	6.66
	57 (13.8)	60.39	60.39	4.33	56.80	56.80	4.74	53.18	53.18	5.18	49.50	49.50	5.66	45.74	45.74	6.16	41.85	41.85	6.68
2000/0.02	62 (16.6)	61.11	55.94	4.33	57.07	53.59	4.74	53.18	53.18	5.18	49.50	49.50	5.66	45.74	45.74	6.16	41.85	41.85	6.68
	63* (17.2)	62.07	45.41	4.34	57.83	43.39	4.75	41.36	41.36	5.19	39.33	49.33	5.66	45.03	37.28	6.15	40.64	35.18	6.67
	67 (19.4)	66.60	46.95	4.38	62.04	44.89	4.79	42.84	42.84	5.23	40.78	52.89	5.69	48.25	38.70	6.19	43.52	36.58	6.70
	72 (22.2)	72.91	37.66	4.43	67.90	35.78	4.85	33.90	33.90	5.28	32.01	57.85	5.75	52.74	30.11	6.24	47.52	28.18	6.74
	57 (13.8)	62.47	62.47	4.43	56.69	58.69	4.84	54.87	54.87	5.28	51.00	51.00	5.75	47.03	47.03	6.25	42.94	42.94	6.77
	62 (16.6)	62.48	62.48	4.43	58.68	58.68	4.84	54.86	54.86	5.28	50.99	50.99	5.75	47.03	47.03	6.25	42.94	42.94	6.77
2250/0.03	63* (17.2)	63.04	48.14	4.43	58.67	46.04	4.84	43.93	43.93	5.28	41.81	49.93	5.74	45.52	39.67	6.23	41.04	37.45	6.75
	67 (19.4)	67.60	49.85	4.47	62.90	47.72	4.88	45.59	45.59	5.32	43.44	53.50	5.78	48.74	41.27	6.27	43.91	39.04	6.78
	72 (22.2)	73.95	39.47	4.53	68.79	37.54	4.94	35.61	35.61	5.37	33.68	58.45	5.84	53.20	31.73	6.32	47.86	29.75	6.82

See Legend and Notes on Page 19.

PERFORMANCE DATA (CONT)

* At 75°F (24°C) entering dry bulb—Tennessee Valley Authority (TVA) rating conditions; all others at 80°F (27°C) dry bulb.

LEGEND

BF— Bypass Factor

edb— Entering Dry—Bulb

Ewb— Entering Wet—Bulb

kW — Total Unit Power Input

SHC— Sensible Heat Capacity (1000 Btuh)

TC — Total Capacity (1000 Btuh) (net)

rh—Relative Humidity

COOLING NOTES:

1. Ratings are net; they account for the effects of the evaporator—fan motor power and heat.
2. Direct interpolation is permissible. Do not extrapolate.
3. The following formulas may be used:

$$t_{ldb} = t_{edb} - \frac{\text{Sensible capacity (Btuh)}}{1.10 \times \text{cfm}}$$

$$t_{lwb} = \text{Wet—bulb temperature corresponding to enthalpy air leaving evaporator coil (} h_{lwb} \text{)}$$

$$h_{lwb} = h_{ewb} - \frac{\text{total capacity (Btuh)}}{4.5 \times \text{cfm}}$$

Where: h_{ewb} = Enthalpy of air entering evaporator coil

4. The SHC is based on 80°F (26.6°C) edb temperature of air entering evaporator coil. Below 80°F (26.6°C) edb, subtract (corr factor x cfm) from SHC.

Above 80°F (26.6°C) edb, add (corr factor x cfm) to SHC.

Correction Factor = $1.10 \times (1 + \text{BF}) \times (\text{edb} - 80)$.

5. Integrated capacity is maximum (instantaneous) capacity less the effect of frost on the outdoor coil and the heat required to defrost it.

48ES--A

Climaproyectos
.com

PERFORMANCE DATA (CONT)

Natural Gas Orifice Sizes and Manifold Pressure

Nameplate Input (Btu/hr)		ALTITUDE OF INSTALLATION (FT. ABOVE SEA LEVEL) U.S.A.*				
		0 to 2000 (0-610 m)	2001 to 3000* (611 to 914 m)	3001 to 4000 (915 to 1219 m)	4001 to 5000 (1220 to 1524 m)	5001 to 6000 (1524 to 1829 m)
40000	Orifice No. (Qty)	44 (2)	45 (2)†	48 (2)†	48 (2)†	48 (2)†
	Manifold Press. (in. W.C.)	3.2	3.2	3.8	3.5	3.2
60000	Orifice No. (Qty)	38 (2)	41 (2)†	41 (2)†	42 (2)†	42 (2)†
	Manifold Press. (in. W.C.)	3.6	3.8	3.4	3.4	3.2
90000	Orifice No. (Qty)	38 (3)	41 (3)†	41 (3)†	42 (3)†	42 (3)†
	Manifold Press. (in. W.C.)	3.6	3.8	3.4	3.4	3.2
115000	Orifice No. (Qty)	33 (3)	36 (3)†	36 (3)†	36 (3)†	38 (3)†
	Manifold Press. (in. W.C.)	3.8	3.8	3.6	3.3	3.6
130000	Orifice No. (Qty)	31 (3)	31 (3)	33 (3)†	33 (3)†	34 (3)†
	Manifold Press. (in. W.C.)	3.8	3.2	3.7	3.4	3.3

*In the U.S.A., the input rating for altitudes above 2000 ft (610m) must be reduced by 4% for each 1000 ft (305 m) above Sea level.

In Canada, the input rating for altitudes from 2001 to 4500 ft (611 to 1372 m) above sea level must be derated by 10% by an authorized gas conversion station or dealer.

For Canadian Installations from 2000 to 4500 ft, use U.S.A. column 2001 to 3000 ft.

Note: Orifice sizes and manifold pressure settings are based on natural gas with a heating value of 1025 Btu/ft³ and a specific gravity of .6.

† Orifices available through your distributor.

Propane Gas Orifice Sizes and Manifold Pressure

Nameplate Input (Btu/hr)		ALTITUDE OF INSTALLATION (FT. ABOVE SEA LEVEL) U.S.A.*				
		0 to 2000 (0-610 m)	2001 to 3000* (611 to 914 m)	3001 to 4000 (915 to 1219 m)	4001 to 5000 (1220 to 1524 m)	5001 to 6000 (1524 to 1829 m)
40000	Orifice No. (Qty)	55 (2)	56 (2)	56 (2)	56 (2)	56 (2)
	Manifold Press. (in. W.C.)	10.0	11.0	11.0	11.0	10.7
60000	Orifice No. (Qty)	53 (2)	54 (2)	54 (2)	54 (2)	54 (2)
	Manifold Press. (in. W.C.)	10.0	11.0	11.0	11.0	11.0
90000	Orifice No. (Qty)	53 (3)	54 (3)	54 (3)	54 (3)	54 (3)
	Manifold Press. (in. W.C.)	10.0	11.0	11.0	11.0	11.0
115000	Orifice No. (Qty)	51 (3)	52 (3)	52 (3)	53 (3)	53 (3)
	Manifold Press. (in. W.C.)	10.0	11.0	10.6	11.0	11.0
130000	Orifice No. (Qty)	49 (3)	50 (3)	51 (3)	52 (3)	52 (3)
	Manifold Press. (in. W.C.)	10.0	11.0	11.0	11.0	11.0

*In the U.S.A., the input rating for altitudes above 2000 ft (610m) must be reduced by 4% for each 1000 ft (305 m) above Sea level.

In Canada, the input rating for altitudes from 2001 to 4500 ft (611 to 1372 m) above sea level must be derated by 10% by an authorized gas conversion station or dealer.

For Canadian Installations from 2000 to 4500 ft, use U.S.A. column 2001 to 3000 ft.

†Use Kit No. CPLPCONV013A00 (0-2000 ft [0-610 m] above sea level). Use Kit No. CPLPCONV014A00 (2001-6000 ft [611-1829 m] above sea level).

High Altitude Compensation, Natural Gas

Nameplate Input (Btu/hr)	Rated Heating Input (Btu/hr), Natural Gas at Installation Altitude Above Sea Level, U.S.A.*				
	0 to 2000 ft (0-610 m)	2001 to 3000 ft* (611 to 914 m)	3001 to 4000 ft (915 to 1219 m)	4001 to 5000 ft (1220 to 1524 m)	5001 to 6000 ft (1524 to 1829 m)
40000	40000	36000	34400	32800	31200
60000	60000	54000	51600	49200	46800
90000	90000	81000	77400	73800	70200
115000	115000	103500	98900	94300	89700
130000	130000	117000	111800	106600	101400

*In the U.S.A., the input rating for altitudes above 2000 ft (610m) must be reduced by 4% for each 1000 ft (305 m) above Sea level.

In Canada, the input rating for altitudes from 2001 to 4500 ft (611 to 1372 m) above sea level must be derated by 10% by an authorized gas conversion station or dealer.

For Canadian Installations from 2000 to 4500 ft (610-1372 m), use U.S.A. column 2001 to 3000 ft (611 to 914 m).

High Altitude Compensation, Propane Gas

Nameplate Input (Btu/hr)	Rated Heating Input (Btu/hr), LP Gas at Installation Altitude Above Sea Level, U.S.A.*				
	0 to 2000 ft (0-610 m)	2001 to 3000 ft* (611 to 914 m)	3001 to 4000 ft (915 to 1219 m)	4001 to 5000 ft (1220 to 1524 m)	5001 to 6000 ft (1524 to 1829 m)
40000	38000	31700	31700	31700	31200
60000	53000	45900	45900	45800	45800
90000	79000	68900	68900	68600	68600
115000	103000	100400	98900	83000	83000
130000	116000	115500	111800	101300	100400

*In the U.S.A., the input rating for altitudes above 2000 ft (610m) must be reduced by 4% for each 1000 ft (305 m) above Sea level.

In Canada, the input rating for altitudes from 2001 to 4500 ft (611 to 1372 m) above sea level must be derated by 10% by an authorized gas conversion station or dealer.

For Canadian Installations from 2000 to 4500 ft (610-1372 m), use U.S.A. column 2001 to 3000 ft (611 to 914 m).

PERFORMANCE DATA (CONT)
Dry Coil Air Delivery* - Horizontal Discharge - Unit 48ES-A24-60

UNIT	HEATING RISE RANGE of (°C)	MOTOR SPEED	WIRE COLOR		EXTERNAL STATIC PRESSURE (IN. W.C.)													
					0.1	0.2	0.3	0.4	0.5	0.6	0.7	0.8	0.9					
48ES(-,N)A30040	30 - 60 (17 - 33)	Low	Blue	CFM	741	638	547	415	--	--	--	--	--	--	--	0.9		
				Heating Rise (°F)	41	47	55	NA	NA	NA	NA	NA	NA	NA	NA	NA	NA	NA
				Heating Rise (°C)	23	26	31	NA	NA	NA	NA	NA	NA	NA	NA	NA	NA	NA
		Med - Low ¹	Pink	CFM	973	887	823	733	665	538	451	--	--	--	--	--	--	--
				Heating Rise (°F)	31	34	37	41	45	56	NA	NA	NA	NA	NA	NA	NA	NA
				Heating Rise (°C)	17	19	20	23	25	31	NA	NA	NA	NA	NA	NA	NA	NA
		Medium	Red	CFM	1088	1023	954	881	800	723	658	563	461	361	277	193	109	25
				Heating Rise (°F)	NA	30	32	34	38	42	46	54	63	72	81	90	100	110
				Heating Rise (°C)	NA	16	18	19	21	23	26	30	34	38	42	46	50	54
		Med - High ²	Orange	CFM	1140	1064	996	915	840	758	687	564	480	396	312	228	144	60
Heating Rise (°F)	NA			NA	30	33	36	40	44	54	64	74	84	94	104	114		
Heating Rise (°C)	NA			NA	17	18	20	22	24	28	32	36	40	44	48	52		
48ES(-,N)A30060	25 - 55 (14 - 31)	High	Black	CFM	1202	1140	1082	1015	961	881	810	732	631	548	465	382	300	
				Heating Rise (°F)	NA	NA	NA	30	31	34	37	41	48	55	62	70	78	86
				Heating Rise (°C)	NA	NA	NA	17	17	19	21	23	27	30	33	36	40	43
		Low	Blue	CFM	741	638	547	415	--	--	--	--	--	--	--	--	--	--
				Heating Rise (°F)	NA	NA	NA	NA	NA	NA	NA	NA	NA	NA	NA	NA	NA	NA
				Heating Rise (°C)	NA	NA	NA	NA	NA	NA	NA	NA	NA	NA	NA	NA	NA	NA
		Med - Low	Pink	CFM	973	887	823	733	665	538	451	--	--	--	--	--	--	--
				Heating Rise (°F)	46	50	54	NA	NA	NA	NA	NA	NA	NA	NA	NA	NA	NA
				Heating Rise (°C)	25	28	30	NA	NA	NA	NA	NA	NA	NA	NA	NA	NA	NA
		Medium	Red	CFM	1088	1023	954	881	800	723	658	563	461	361	277	193	109	25
Heating Rise (°F)	41			43	47	50	NA	NA	NA	NA	NA	NA	NA	NA	NA	NA		
Heating Rise (°C)	23			24	26	28	NA	NA	NA	NA	NA	NA	NA	NA	NA	NA		
Med - High ²	Orange	CFM	1140	1064	996	915	840	758	687	564	480	396	312	228	144	60		
		Heating Rise (°F)	39	42	45	49	53	NA	NA	NA	NA	NA	NA	NA	NA	NA		
		Heating Rise (°C)	22	23	25	27	29	NA	NA	NA	NA	NA	NA	NA	NA	NA		
High ¹	Black	CFM	1202	1140	1082	1015	961	881	810	732	631	548	465	382	300	217		
		Heating Rise (°F)	37	39	41	44	46	50	55	63	72	81	91	101	111	121		
		Heating Rise (°C)	21	22	23	24	26	28	30	33	36	40	44	48	52	56		

PERFORMANCE DATA (CONT)
Dry Coil Air Delivery* - Horizontal Discharge - Unit 48ES-A24-60

UNIT	HEATING RISE RANGE of (°C)	MOTOR SPEED	WIRE COLOR	CFM	EXTERNAL STATIC PRESSURE (IN. W.C.)										
					0.1	0.2	0.3	0.4	0.5	0.6	0.7	0.8	0.9		
48ES(-,N)A36060	25 - 55 (14 - 31)	Low ¹	Blue	CFM	1234	1168	1093	1021	961	894	825	759	687		
				Heating Rise (°F)	36	38	41	44	46	50	54	NA	NA		
				Heating Rise (°C)	20	21	23	24	26	28	30	NA	NA		
		Med-Low	Pink	CFM	1290	1223	1154	1090	1027	977	894	828	762		
				Heating Rise (°F)	34	36	39	41	43	45	50	54	NA		
				Heating Rise (°C)	19	20	21	23	24	25	28	30	NA		
	Medium ²	Red	CFM	1354	1290	1226	1158	1102	1046	981	918	843			
			Heating Rise (°F)	33	34	36	38	40	42	45	48	53			
			Heating Rise (°C)	18	19	20	21	22	24	24	25	27			
			Med-High	Orange	CFM	1606	1546	1489	1430	1371	1316	1258	1208	1140	
					Heating Rise (°F)	28	29	30	31	32	34	35	37	39	
					Heating Rise (°C)	15	16	17	17	18	19	20	20	22	
48ES(-,N)A36090	35 - 65 (19 - 36)	High	Black	CFM	1630	1580	1517	1463	1407	1339	1277	1210	1131		
				Heating Rise (°F)	27	28	29	30	32	33	35	37	39		
				Heating Rise (°C)	15	16	16	17	18	18	19	19	20		
		Low	Blue	CFM	1234	1168	1093	1021	961	894	825	759	687		
				Heating Rise (°F)	55	58	62	NA	NA	NA	NA	NA	NA		
				Heating Rise (°C)	31	32	35	NA	NA	NA	NA	NA	NA		
	Med-Low	Pink	CFM	1290	1223	1154	1090	1027	977	894	828	762			
			Heating Rise (°F)	53	56	59	62	NA	NA	NA	NA	NA			
			Heating Rise (°C)	29	31	33	35	NA	NA	NA	NA	NA			
			Medium ²	Red	CFM	1354	1290	1226	1158	1102	1046	981	918	843	
					Heating Rise (°F)	50	53	55	59	62	65	65	NA	NA	
					Heating Rise (°C)	28	29	31	33	34	36	36	NA	NA	
Med-High	Orange	CFM	1606	1546	1489	1430	1371	1316	1258	1208	1140				
		Heating Rise (°F)	42	44	46	48	50	52	54	56	60				
		Heating Rise (°C)	24	24	25	26	28	29	30	31	33				
		High ¹	Black	CFM	1630	1580	1517	1463	1407	1339	1277	1210	1131		
				Heating Rise (°F)	42	43	45	46	48	51	53	56	60		
				Heating Rise (°C)	23	24	25	26	27	28	30	31	33		

PERFORMANCE DATA (CONT)
Dry Coil Air Delivery* - Horizontal Discharge - Unit 48ES-A24-60

UNIT	HEATING RISE RANGE of (°C)	MOTOR SPEED	WIRE COLOR	CFM	EXTERNAL STATIC PRESSURE (IN. W.C.)										
					0.1	0.2	0.3	0.4	0.5	0.6	0.7	0.8	0.9		
48ES(-,N)A42060	25 - 55 (14 - 31)	Low ¹	Blue	CFM	1295	1234	1182	1126	1075	1016	955	898	857		
				Heating Rise (°F)	34	36	38	39	41	44	47	49	52		
		Med-Low	Pink	Heating Rise (°C)	19	20	21	22	23	24	26	27	29		
				CFM	1345	1282	1235	1194	1140	1095	1027	974	921		
		Medium	Red	Heating Rise (°F)	33	35	36	37	39	41	43	46	48		
				Heating Rise (°C)	18	19	20	21	22	23	24	25	27		
		Med-High ²	Orange	CFM	1505	1452	1413	1358	1323	1282	1234	1169	1130		
				Heating Rise (°F)	30	31	31	33	34	35	36	38	39		
		High	Black	Heating Rise (°C)	16	17	17	18	19	19	20	21	22		
				CFM	1545	1492	1449	1411	1362	1313	1278	1231	1188		
Low	Blue	Heating Rise (°F)	29	30	31	31	33	34	35	36	37				
		Heating Rise (°C)	16	17	17	17	18	19	19	20	21				
Med-Low	Pink	CFM	1705	1643	1607	1568	1518	1483	1448	1404	1360				
		Heating Rise (°F)	26	27	28	28	29	30	31	32	33				
High	Black	Heating Rise (°C)	14	15	15	16	16	17	17	18	18				
		CFM	1295	1234	1182	1126	1075	1016	955	898	857				
Med-Low	Orange	Heating Rise (°F)	53	55	58	60	63	66	69	72	75				
		Heating Rise (°C)	29	31	32	34	35	36	37	38	39				
High	Black	CFM	1345	1282	1235	1194	1140	1095	1027	974	921				
		Heating Rise (°F)	51	53	55	57	60	62	64	66	68				
Med-Low	Pink	Heating Rise (°C)	28	29	31	32	33	35	36	37	38				
		CFM	1505	1452	1413	1358	1323	1282	1234	1169	1130				
High	Black	Heating Rise (°F)	45	47	48	50	51	53	55	58	60				
		Heating Rise (°C)	25	26	27	28	29	29	31	32	33				
Med-Low	Orange	CFM	1545	1492	1449	1411	1362	1313	1278	1231	1188				
		Heating Rise (°F)	44	46	47	48	50	52	53	55	57				
High	Black	Heating Rise (°C)	24	25	26	27	28	29	30	31	32				
		CFM	1705	1643	1607	1568	1518	1483	1448	1404	1360				
Med-Low	Pink	Heating Rise (°F)	40	41	42	43	45	46	48	49	50				
		Heating Rise (°C)	22	23	24	24	25	25	26	27	28				

PERFORMANCE DATA (CONT)
Dry Coil Air Delivery* - Horizontal Discharge - Unit 48ES-A24-60

UNIT	HEATING RISE RANGE of (°C)	MOTOR SPEED	WIRE COLOR	CFM	EXTERNAL STATIC PRESSURE (IN. W.C.)									
					0.1	0.2	0.3	0.4	0.5	0.6	0.7	0.8	0.9	
48ES(-,N)A48090	35 - 65 (19 - 36)	Low ¹	Blue	CFM	1402	1351	1311	1263	1224	1172	1136	1080	1041	
				Heating Rise (°F)	49	50	52	54	56	58	60	63	65	
		Med-Low	Pink	CFM	1457	1404	1367	1318	1284	1233	1197	1144	1104	
				Heating Rise (°F)	47	48	50	52	53	55	57	59	62	
		Medium ²	Red	CFM	1736	1695	1642	1601	1553	1512	1465	1427	1381	
				Heating Rise (°F)	39	40	41	42	44	45	46	48	49	
		Med-High	Orange	CFM	2149	2111	2062	2026	1980	1945	1905	1864	1803	
				Heating Rise (°F)	NA	NA	NA	NA	NA	35	36	36	38	
		High	Black	CFM	2844	2306	2259	2203	2141	2070	1991	1902	1803	
				Heating Rise (°F)	NA	NA	NA	NA	NA	NA	NA	NA	38	
Low	Blue	CFM	1402	1351	1311	1263	1224	1172	1136	1080	1041			
		Heating Rise (°F)	NA	NA	NA	NA	NA	NA	NA	NA	NA			
Med-Low	Pink	CFM	1457	1404	1367	1318	1284	1233	1197	1144	1104			
		Heating Rise (°F)	60	NA	NA	NA	NA	NA	NA	NA	NA			
Medium ²	Red	CFM	1736	1695	1642	1601	1553	1512	1465	1427	1381			
		Heating Rise (°F)	50	51	53	54	56	57	59	NA	NA			
Med-High ¹	Orange	CFM	2149	2111	2062	2026	1980	1945	1905	1864	1793			
		Heating Rise (°F)	40	41	42	43	44	45	46	47	48			
High	Black	CFM	2844	2306	2259	2203	2141	2070	1991	1902	1803			
		Heating Rise (°F)	37	38	38	39	41	42	44	46	48			

PERFORMANCE DATA (CONT)
Dry Coil Air Delivery* - Horizontal Discharge - Unit 48ES-A24-60

UNIT	HEATING RISE RANGE of (°C)	MOTOR SPEED	WIRE COLOR	CFM	EXTERNAL STATIC PRESSURE (IN. W.C.)																			
					0.1	0.2	0.3	0.4	0.5	0.6	0.7	0.8	0.9											
48ES(-,N)A48130	35 - 65 (19 - 36)	Low	Blue	CFM	1402	1351	1311	1263	1224	1172	1136	1080	1041											
				Heating Rise (°F)	NA	NA	NA	NA	NA	NA	NA	NA	NA	NA	NA	NA	NA	NA	NA	NA	NA	NA	NA	
		Med-Low	Pink	CFM	1457	1404	1367	1318	1284	1233	1197	1144	1104											
				Heating Rise (°F)	NA	NA	NA	NA	NA	NA	NA	NA	NA	NA	NA	NA	NA	NA	NA	NA	NA	NA	NA	NA
		Medium ²	Red	CFM	1736	1695	1642	1601	1553	1512	1465	1427	1381											
				Heating Rise (°F)	55	57	59	60	62	64	NA	NA	NA	NA	NA	NA	NA	NA	NA	NA	NA	NA	NA	NA
		Med-High ¹	Orange	CFM	2149	2111	2062	2026	1980	1945	1905	1864	1803											
				Heating Rise (°F)	45	46	47	48	49	50	51	52	54											
		High	Black	CFM	2344	2306	2259	2203	2141	2070	1991	1902	1803											
				Heating Rise (°F)	41	42	43	44	45	47	48	51	53											
Low ¹	Blue	CFM	1445	1389	1341	1281	1236	1189	1139	1072	1027													
		Heating Rise (°F)	47	49	51	53	55	57	60	63	63													
Med-Low	Pink	CFM	1678	1635	1602	1558	1513	1474	1438	1404	1349													
		Heating Rise (°F)	41	42	42	44	45	46	47	48	50													
Medium ²	Red	CFM	1962	1915	1880	1843	1794	1753	1711	1675	1628													
		Heating Rise (°F)	35	36	36	37	38	39	40	41	42													
Med-High	Orange	CFM	2131	2088	2065	2013	1982	1941	1888	1860	1785													
		Heating Rise (°F)	NA	NA	NA	NA	NA	35	36	37	38													
High	Black	CFM	2461	2409	2339	2286	2192	2140	2062	1968	1874													
		Heating Rise (°F)	NA	NA	NA	NA	NA	NA	NA	NA	36													

PERFORMANCE DATA (CONT)
Dry Coil Air Delivery* - Horizontal Discharge - Unit 48ES-A24-60

UNIT	HEATING RISE RANGE °F (°C)	MOTOR SPEED	WIRE COLOR		EXTERNAL STATIC PRESSURE (IN. W.C.)									
					0.1	0.2	0.3	0.4	0.5	0.6	0.7	0.8	0.9	
48ES(-,N)/A60115	30 - 60 (17 - 33)	Low	Blue	CFM	1445	1389	1341	1281	1236	1189	1139	1072	1027	
				Heating Rise (°F)	60	NA	NA	NA	NA	NA	NA	NA	NA	
				Heating Rise (°C)	33	NA	NA	NA	NA	NA	NA	NA	NA	
		Med-Low	Pink	CFM	1678	1635	1602	1558	1513	1474	1438	1404	1349	
				Heating Rise (°F)	52	53	54	56	57	59	60	NA	NA	
				Heating Rise (°C)	29	30	30	31	32	33	34	NA	NA	
	Medium ²	Red	CFM	1962	1915	1880	1843	1794	1753	1711	1675	1628		
			Heating Rise (°F)	44	45	46	47	48	50	51	52	53		
			Heating Rise (°C)	25	25	26	26	27	28	28	29	30		
	Med-High ¹	Orange	CFM	2131	2088	2065	2013	1982	1941	1888	1860	1785		
			Heating Rise (°F)	41	42	42	43	44	45	46	47	49		
			Heating Rise (°C)	23	23	23	24	24	25	26	26	27		
High	Black	CFM	2461	2409	2339	2286	2192	2140	2062	1968	1874			
		Heating Rise (°F)	35	36	37	38	40	41	42	44	46			
		Heating Rise (°C)	20	20	21	21	22	23	23	25	26			

PERFORMANCE DATA (CONT)
Dry Coil Air Delivery* - Horizontal Discharge - Unit 48ES-A24-60

UNIT	HEATING RISE RANGE °F (°C)	MOTOR SPEED	WIRE COLOR	CFM	EXTERNAL STATIC PRESSURE (IN. W.C.)									
					0.1	0.2	0.3	0.4	0.5	0.6	0.7	0.8	0.9	
48ES(-,N)/A60130	Low	Blue	CFM	1445	1389	1341	1281	1236	1189	1139	1072	1027		
			Heating Rise (°F)	NA	NA	NA	NA	NA	NA	NA	NA	NA	NA	NA
			Heating Rise (°C)	NA	NA	NA	NA	NA	NA	NA	NA	NA	NA	NA
			CFM	1678	1635	1602	1558	1513	1474	1438	1404	1349		
			Heating Rise (°F)	57	59	60	62	64	65	65	65	65	65	65
			Heating Rise (°C)	32	33	33	34	35	36	36	36	36	36	36
	Med-Low	Pink	CFM	1962	1915	1880	1843	1794	1753	1711	1675	1628		
			Heating Rise (°F)	49	50	51	52	54	55	55	55	55	55	55
			Heating Rise (°C)	27	28	28	29	30	31	31	31	31	31	31
			CFM	2131	2088	2065	2013	1982	1941	1888	1860	1874		
			Heating Rise (°F)	45	46	47	48	49	50	51	52	54		
			Heating Rise (°C)	25	26	26	27	27	28	28	28	29	30	
Med-High ¹	Orange	CFM	2461	2409	2339	2286	2192	2140	2062	1968	1874			
		Heating Rise (°F)	39	40	41	42	44	45	45	45	45	45	45	
		Heating Rise (°C)	22	22	23	23	24	25	25	25	25	25	25	
		CFM	2461	2409	2339	2286	2192	2140	2062	1968	1874			
		Heating Rise (°F)	39	40	41	42	44	45	45	45	45	45	45	
		Heating Rise (°C)	22	22	23	23	24	25	25	25	25	25	25	

*Air delivery values are without air filter and are for dry coil (See 48ES-A Wet Coil Pressure Drop table).

¹ Factory-shipped heating speed

² Factory-shipped cooling speed

"NA" = Not allowed for heating speed

Note: Duct field-supplied air filter pressure drop and wet coil pressure drop to obtain external static pressure available for ducting.

Shaded areas indicate speed/static combinations that are not permitted for dehumidification speed.

Note: Deduct 10% for 208 volt operation.

Dry Coil Air Delivery - Downflow Discharge

UNIT	HEATING RISE RANGE	MOTOR SPEED	WIRE COLOR	EXTERNAL STATIC PRESSURE (IN. W.C.)																						
				0.1	0.2	0.3	0.4	0.5	0.6	0.7	0.8	0.9	1.0													
48ES(-,N)A24040	30 - 60°F (17 - 33°C)	Low	Blue	CFM	809	664	554	447	---	---	---	---	---	---	---	---	---	---	---	---	---	---				
				WATTS	85	82	87	95	---	---	---	---	---	---	---	---	---	---	---	---	---	---	---	---		
				BHP	0.09	0.09	0.09	0.10	---	---	---	---	---	---	---	---	---	---	---	---	---	---	---	---	---	
				Heating Rise (°F)	37	46	55	NA	---	---	---	---	---	---	---	---	---	---	---	---	---	---	---	---	---	
				Heating Rise (°C)	21	25	30	NA	---	---	---	---	---	---	---	---	---	---	---	---	---	---	---	---	---	---
				CFM	875	787	693	612	498	392	---	---	---	---	---	---	---	---	---	---	---	---	---	---	---	---
		Med-Low	Pink	WATTS	101	111	115	125	131	142	---	---	---	---	---	---	---	---	---	---	---	---	---	---	---	
				BHP	0.11	0.12	0.12	0.13	0.14	0.15	---	---	---	---	---	---	---	---	---	---	---	---	---	---	---	
				Heating Rise (°F)	35	38	44	49	NA	NA	---	---	---	---	---	---	---	---	---	---	---	---	---	---	---	
				Heating Rise (°C)	19	21	24	27	NA	NA	---	---	---	---	---	---	---	---	---	---	---	---	---	---	---	
				CFM	939	860	748	663	591	472	399	---	---	---	---	---	---	---	---	---	---	---	---	---	---	---
				WATTS	119	124	134	138	147	155	164	---	---	---	---	---	---	---	---	---	---	---	---	---	---	---
Med-High ¹	Orange	BHP	0.13	0.13	0.14	0.15	0.16	0.17	0.18	0.18	0.17	0.16	0.15	0.14	0.13	0.12	0.11	0.10	0.09	0.08	0.07	0.06	0.05			
		Heating Rise (°F)	32	35	40	46	51	NA	NA	---	---	---	---	---	---	---	---	---	---	---	---	---	---	---		
		Heating Rise (°C)	18	20	22	25	28	NA	NA	---	---	---	---	---	---	---	---	---	---	---	---	---	---	---		
		CFM	1026	949	873	786	694	604	516	---	---	---	---	---	---	---	---	---	---	---	---	---	---	---		
		WATTS	146	151	161	167	177	183	195	---	---	---	---	---	---	---	---	---	---	---	---	---	---	---		
		BHP	0.16	0.16	0.17	0.18	0.19	0.20	0.21	---	---	---	---	---	---	---	---	---	---	---	---	---	---	---		
High	Black	Heating Rise (°F)	NA	32	35	38	44	50	59	---	---	---	---	---	---	---	---	---	---	---	---	---	---			
		Heating Rise (°C)	NA	18	19	21	24	28	28	33	---	---	---	---	---	---	---	---	---	---	---	---	---			
		CFM	1264	1202	1134	1070	1002	931	870	806	746	686	626	566	506	446	386	326	266	206	146	86	26			
		WATTS	250	261	274	279	290	296	308	319	328	338	348	358	368	378	388	398	408	418	428	438	448			
		BHP	0.27	0.28	0.29	0.30	0.31	0.32	0.33	0.34	0.35	0.36	0.37	0.38	0.39	0.40	0.41	0.42	0.43	0.44	0.45	0.46	0.47			
		Heating Rise (°C)	NA	NA	NA	NA	30	32	35	37	43	50	58	66	74	82	90	98	106	114	122	130	138			

Dry Coil Air Delivery - Downflow Discharge

UNIT	HEATING RISE RANGE	MOTOR SPEED	WIRE COLOR	EXTERNAL STATIC PRESSURE (IN. W.C.)																
				0.1	0.2	0.3	0.4	0.5	0.6	0.7	0.8	0.9	1.0							
48ES(-,N)A30040	30 - 60°F (17 - 33°C)	Low	Blue	CFM	756	689	548	457	---	---	---	---	---	---	---	---	---	---		
				WATTS	84	90	96	106	---	---	---	---	---	---	---	---	---	---	---	
				BHP	0.09	0.10	0.10	0.11	---	---	---	---	---	---	---	---	---	---	---	---
				Heating Rise (°F)	40	45	55	NA	---	---	---	---	---	---	---	---	---	---	---	---
				Heating Rise (°C)	22	25	31	NA	---	---	---	---	---	---	---	---	---	---	---	---
				CFM	1002	928	842	733	660	560	450	---	---	---	---	---	---	---	---	---
		Med-Low	Pink	WATTS	144	155	161	173	185	192	203	---	---	---	---	---	---	---	---	
				BHP	0.15	0.17	0.17	0.19	0.20	0.21	0.22	---	---	---	---	---	---	---	---	
				Heating Rise (°F)	30	33	36	41	46	54	NA	---	---	---	---	---	---	---	---	
				Heating Rise (°C)	17	18	20	23	25	30	NA	---	---	---	---	---	---	---	---	
				CFM	1110	1025	967	879	814	706	611	509	461	---	---	---	---	---	---	
				WATTS	188	195	205	211	223	236	243	255	243	---	---	---	---	---	---	
Medium ²	Red	BHP	0.20	0.21	0.22	0.23	0.24	0.25	0.26	0.27	0.26	0.27	0.26	0.27	0.26	0.26	0.26			
		Heating Rise (°F)	27	29	31	34	37	43	49	59	NA	---	---	---	---	---	---			
		Heating Rise (°C)	15	16	17	19	21	24	27	33	NA	---	---	---	---	---	---			
		CFM	1160	1091	1004	945	866	804	699	615	496	---	---	---	---	---	---			
		WATTS	213	225	232	243	249	261	273	285	291	---	---	---	---	---	---			
		BHP	0.23	0.24	0.25	0.26	0.27	0.28	0.29	---	---	---	---	---	---	---	---			
Med-High ¹	Orange	Heating Rise (°F)	NA	NA	30	32	35	38	43	49	NA	---	---	---	---	---				
		Heating Rise (°C)	NA	NA	17	18	19	21	24	27	NA	---	---	---	---	---				
		CFM	1240	1173	1110	1031	966	902	821	726	626	---	---	---	---	---				
		WATTS	254	266	274	284	295	302	315	327	331	---	---	---	---	---				
		BHP	0.27	0.29	0.29	0.30	0.32	0.32	0.34	0.35	0.35	---	---	---	---	---				
		Heating Rise (°F)	NA	NA	NA	NA	31	34	37	42	48	---	---	---	---	---				
High	Black	Heating Rise (°C)	NA	NA	NA	NA	17	19	20	23	27	27	23	27	---	---				
		CFM	1240	1173	1110	1031	966	902	821	726	626	---	---	---	---					
		WATTS	254	266	274	284	295	302	315	327	331	---	---	---	---					
		BHP	0.27	0.29	0.29	0.30	0.32	0.32	0.34	0.35	0.35	---	---	---	---					
		Heating Rise (°F)	NA	NA	NA	NA	31	34	37	42	48	---	---	---	---					
		Heating Rise (°C)	NA	NA	NA	NA	17	19	20	23	27	---	---	---	---					

Dry Coil Air Delivery - Downflow Discharge

UNIT	HEATING RISE RANGE	MOTOR SPEED	WIRE COLOR	EXTERNAL STATIC PRESSURE (IN. W.C.)										
				0.1	0.2	0.3	0.4	0.5	0.6	0.7	0.8	0.9	1.0	
48ES(-,N)A36060	25 - 55°F (14 - 31°C)	Low	Blue	CFM	1277	1215	1147	1094	1045	992	932	874	826	757
				WATTS	285	289	299	305	314	319	328	335	347	352
				BHP	0.31	0.31	0.32	0.33	0.34	0.34	0.35	0.36	0.37	0.38
				Heating Rise (°F)	NA	25	26	28	29	30	32	35	37	40
				Heating Rise (°C)	NA	14	15	15	16	17	18	19	20	22
				CFM	1312	1260	1203	1153	1095	1050	995	943	889	829
		Med-Low	Pink	WATTS	314	324	329	340	344	355	361	372	382	387
				BHP	0.34	0.35	0.35	0.36	0.37	0.38	0.39	0.40	0.41	0.42
				Heating Rise (°F)	NA	NA	25	26	28	29	30	32	34	36
				Heating Rise (°C)	NA	NA	14	15	15	16	17	18	19	20
				CFM	1381	1326	1269	1212	1161	1121	1070	1019	974	912
				WATTS	358	365	375	383	391	395	406	418	424	434
Med-High ¹	Orange	BHP	0.38	0.39	0.40	0.41	0.42	0.42	0.44	0.45	0.45	0.47		
		Heating Rise (°F)	NA	NA	NA	25	26	27	28	30	31	33		
		Heating Rise (°C)	NA	NA	NA	14	14	15	16	16	17	18		
		CFM	1631	1579	1525	1477	1423	1372	1336	1284	1233	1166		
		WATTS	567	576	581	592	598	609	617	619	613	598		
		BHP	0.61	0.62	0.62	0.63	0.64	0.65	0.66	0.66	0.66	0.64		
High	Black	Heating Rise (°F)	NA	NA	NA	NA	NA	NA	NA	NA	NA	25	26	
		Heating Rise (°C)	NA	NA	NA	NA	NA	NA	NA	NA	NA	14	14	
		CFM	1681	1633	1575	1526	1478	1415	1366	1312	1249	1159		
		WATTS	618	626	636	644	652	653	649	642	627	602		
		BHP	0.66	0.67	0.68	0.69	0.70	0.70	0.70	0.69	0.67	0.65		
		Heating Rise (°F)	NA	NA	NA	NA	NA	NA	NA	NA	NA	NA	26	
Heating Rise (°C)	NA	NA	NA	NA	NA	NA	NA	NA	NA	NA	14			

Dry Coil Air Delivery - Downflow Discharge

UNIT	HEATING RISE RANGE	MOTOR SPEED	WIRE COLOR	EXTERNAL STATIC PRESSURE (IN. W.C.)										
				0.1	0.2	0.3	0.4	0.5	0.6	0.7	0.8	0.9	1.0	
48ES(-.N)A36090	35 - 65°F (19 - 36°C)	Low	Blue	CFM	1277	1215	1147	1094	1045	992	932	874	826	757
				WATTS	285	289	299	305	314	319	328	335	347	352
				BHP	0.31	0.31	0.32	0.33	0.34	0.34	0.35	0.36	0.37	0.38
				Heating Rise (°F)	NA	25	26	28	29	30	32	35	37	40
				Heating Rise (°C)	NA	14	15	15	16	17	18	19	20	22
				CFM	1312	1260	1203	1153	1095	1050	995	943	889	829
		Med-Low	Pink	WATTS	314	324	329	340	344	355	361	372	382	387
				BHP	0.34	0.35	0.35	0.36	0.37	0.38	0.39	0.40	0.41	0.42
				Heating Rise (°F)	NA	NA	25	26	28	29	30	32	34	36
				Heating Rise (°C)	NA	NA	14	15	15	16	17	18	19	20
				CFM	1381	1326	1269	1212	1161	1121	1070	1019	974	912
				WATTS	358	365	375	383	391	395	406	418	424	434
Med-High ¹	Orange	BHP	0.38	0.39	0.40	0.41	0.42	0.42	0.44	0.45	0.45	0.47		
		Heating Rise (°F)	NA	NA	NA	25	26	27	28	30	31	33		
		Heating Rise (°C)	NA	NA	NA	14	14	15	16	16	17	18		
		CFM	1631	1579	1525	1477	1423	1372	1336	1284	1233	1166		
		WATTS	567	576	581	592	598	609	617	619	613	598		
		BHP	0.61	0.62	0.62	0.63	0.64	0.65	0.66	0.66	0.66	0.64		
High	Black	Heating Rise (°F)	NA	NA	NA	NA	NA	NA	NA	NA	NA	25	26	
		Heating Rise (°C)	NA	NA	NA	NA	NA	NA	NA	NA	NA	14	14	
		CFM	1681	1633	1575	1526	1478	1415	1366	1312	1249	1159		
		WATTS	618	626	636	644	652	653	649	642	627	602		
		BHP	0.66	0.67	0.68	0.69	0.70	0.70	0.70	0.69	0.67	0.65		
		Heating Rise (°F)	NA	NA	NA	NA	NA	NA	NA	NA	NA	NA	26	
Heating Rise (°C)	NA	NA	NA	NA	NA	NA	NA	NA	NA	NA	14			

Dry Coil Air Delivery - Downflow Discharge

UNIT	HEATING RISE RANGE	MOTOR SPEED	WIRE COLOR	EXTERNAL STATIC PRESSURE (IN. W.C.)										
				0.1	0.2	0.3	0.4	0.5	0.6	0.7	0.8	0.9	1.0	
48ES(-.N)A42060	25 - 55°F (14 - 31°C)	Low ¹	Blue	CFM	1365	1324	1284	1233	1181	1127	1084	1039	984	939
				WATTS	177	189	201	210	222	236	248	261	269	281
				BHP	0.19	0.20	0.22	0.23	0.24	0.25	0.27	0.28	0.29	0.30
				Heating Rise (°F)	NA	34	35	36	38	39	41	43	45	47
				Heating Rise (°C)	NA	19	19	20	21	22	23	24	25	26
				CFM	1425	1384	1339	1301	1254	1199	1151	1104	1065	1015
		WATTS	197	210	223	235	248	257	271	284	296	305		
		BHP	0.21	0.23	0.24	0.25	0.27	0.28	0.29	0.30	0.32	0.33		
		Heating Rise (°F)	NA	NA	NA	34	35	37	39	40	42	44		
		Heating Rise (°C)	NA	NA	NA	19	20	21	21	22	23	24		
		CFM	1582	1549	1509	1469	1433	1392	1346	1300	1249	1213		
		WATTS	267	280	294	308	322	336	344	359	374	387		
BHP	0.29	0.30	0.32	0.33	0.35	0.36	0.37	0.38	0.40	0.42				
Heating Rise (°F)	NA	NA	NA	NA	NA	NA	NA	34	36	37				
Heating Rise (°C)	NA	NA	NA	NA	NA	NA	NA	19	20	20				
CFM	1623	1586	1553	1511	1470	1433	1393	1350	1309	1261				
WATTS	285	299	312	324	335	349	363	378	393	407				
BHP	0.31	0.32	0.33	0.35	0.36	0.37	0.39	0.41	0.42	0.44				
Heating Rise (°F)	NA	NA	NA	NA	NA	NA	NA	NA	34	35				
Heating Rise (°C)	NA	NA	NA	NA	NA	NA	NA	NA	19	20				
CFM	1775	1736	1696	1660	1622	1588	1557	1516	1472	1426				
WATTS	371	386	401	410	424	439	453	468	483	497				
BHP	0.40	0.41	0.43	0.44	0.45	0.47	0.49	0.50	0.52	0.53				
Heating Rise (°F)	NA	NA	NA	NA	NA	NA	NA	NA	NA	NA				
Heating Rise (°C)	NA	NA	NA	NA	NA	NA	NA	NA	NA	NA				

Dry Coil Air Delivery - Downflow Discharge

UNIT	HEATING RISE RANGE	MOTOR SPEED	WIRE COLOR	EXTERNAL STATIC PRESSURE (IN. W.C.)										
				0.1	0.2	0.3	0.4	0.5	0.6	0.7	0.8	0.9	1.0	
48ES(-.N)A42090	35 - 65°F (19 - 36°C)	Low ¹	Blue	CFM	1365	1324	1284	1233	1181	1127	1084	1039	984	939
				WATTS	177	189	201	210	222	236	248	261	269	281
				BHP	0.19	0.20	0.22	0.23	0.24	0.25	0.27	0.28	0.29	0.30
				Heating Rise (°F)	NA	34	35	36	38	39	41	43	45	47
				Heating Rise (°C)	NA	19	19	20	21	22	23	24	25	26
				CFM	1425	1384	1339	1301	1254	1199	1151	1104	1065	1015
		WATTS	197	210	223	235	248	257	271	284	296	305		
		BHP	0.21	0.23	0.24	0.25	0.27	0.28	0.29	0.30	0.32	0.33		
		Heating Rise (°F)	NA	NA	NA	34	35	37	39	40	42	44		
		Heating Rise (°C)	NA	NA	NA	19	20	21	21	22	23	24		
		CFM	1582	1549	1509	1469	1433	1392	1346	1300	1249	1213		
		WATTS	267	280	294	308	322	336	344	359	374	387		
BHP	0.29	0.30	0.32	0.33	0.35	0.36	0.37	0.38	0.40	0.42				
Heating Rise (°F)	NA	NA	NA	NA	NA	NA	NA	34	36	37				
Heating Rise (°C)	NA	NA	NA	NA	NA	NA	NA	19	20	20				
CFM	1623	1586	1553	1511	1470	1433	1393	1350	1309	1261				
WATTS	285	299	312	324	335	349	363	378	393	407				
BHP	0.31	0.32	0.33	0.35	0.36	0.37	0.39	0.41	0.42	0.44				
Heating Rise (°F)	NA	NA	NA	NA	NA	NA	NA	NA	34	35				
Heating Rise (°C)	NA	NA	NA	NA	NA	NA	NA	NA	19	20				
CFM	1775	1736	1696	1660	1622	1588	1557	1516	1472	1426				
WATTS	371	386	401	410	424	439	453	468	483	497				
BHP	0.40	0.41	0.43	0.44	0.45	0.47	0.49	0.50	0.52	0.53				
Heating Rise (°F)	NA	NA	NA	NA	NA	NA	NA	NA	NA	NA				
Heating Rise (°C)	NA	NA	NA	NA	NA	NA	NA	NA	NA	NA				

Dry Coil Air Delivery - Downflow Discharge

UNIT	HEATING RISE RANGE	MOTOR SPEED	WIRE COLOR	EXTERNAL STATIC PRESSURE (IN. W.C.)										
				0.1	0.2	0.3	0.4	0.5	0.6	0.7	0.8	0.9	1.0	
48ES(-.N)A48090	35 - 65°F (19 - 36°C)	Low ¹	Blue	CFM	1503	1457	1423	1374	1330	1287	1241	1199	1153	1111
				WATTS	225	233	246	254	269	282	292	307	314	329
				BHP	0.24	0.25	0.26	0.27	0.29	0.30	0.31	0.33	0.34	0.35
				Heating Rise (°F)	45	47	48	49	51	53	55	57	59	61
				Heating Rise (°C)	25	26	27	27	28	29	30	32	33	34
				CFM	1556	1508	1461	1432	1388	1346	1302	1256	1221	1168
		WATTS	244	261	268	281	290	305	319	330	345	353		
		BHP	0.26	0.28	0.29	0.30	0.31	0.33	0.34	0.35	0.37	0.38		
		Heating Rise (°F)	44	45	47	47	49	51	52	54	56	58		
		Heating Rise (°C)	24	25	26	26	27	28	29	30	31	32		
		CFM	1861	1822	1786	1758	1716	1688	1660	1619	1583	1539		
		WATTS	400	417	426	441	452	467	482	492	507	519		
BHP	0.43	0.45	0.46	0.47	0.48	0.50	0.52	0.53	0.54	0.56				
Heating Rise (°F)	37	37	38	39	40	40	41	42	43	44				
Heating Rise (°C)	20	21	21	21	22	22	23	23	24	25				
CFM	2319	2291	2255	2230	2193	2166	2118	2057	1992	1887				
WATTS	758	769	787	799	808	823	822	805	780	737				
BHP	0.81	0.82	0.84	0.86	0.87	0.88	0.88	0.86	0.84	0.79				
Heating Rise (°F)	NA	NA	NA	NA	NA	NA	NA	NA	NA	36				
Heating Rise (°C)	NA	NA	NA	NA	NA	NA	NA	NA	NA	20				
CFM	2532	2487	2444	2391	2330	2259	2179	2111	2033	1949				
WATTS	1014	1022	1015	994	965	935	898	858	823	786				
BHP	1.09	1.10	1.09	1.07	1.03	1.00	0.96	0.92	0.88	0.84				
Heating Rise (°F)	NA	NA	NA	NA	NA	NA	NA	NA	NA	35				
Heating Rise (°C)	NA	NA	NA	NA	NA	NA	NA	NA	NA	19				

Dry Coil Air Delivery - Downflow Discharge

UNIT	HEATING RISE RANGE	MOTOR SPEED	WIRE COLOR	EXTERNAL STATIC PRESSURE (IN. W.C.)										
				0.1	0.2	0.3	0.4	0.5	0.6	0.7	0.8	0.9	1.0	
48ES(-.N)A48115	30 - 60°F (17 - 33°C)	Low ¹	Blue	CFM	1503	1457	1423	1374	1330	1287	1241	1199	1153	1111
				WATTS	225	233	246	254	269	282	292	307	314	329
				BHP	0.24	0.25	0.26	0.27	0.29	0.30	0.31	0.33	0.34	0.35
				Heating Rise (°F)	45	47	48	49	51	53	55	57	59	61
				Heating Rise (°C)	25	26	27	27	28	29	30	32	33	34
				CFM	1556	1508	1461	1432	1388	1346	1302	1256	1221	1168
		Med-Low	Pink	WATTS	244	261	268	281	290	305	319	330	345	353
				BHP	0.26	0.28	0.29	0.30	0.31	0.33	0.34	0.35	0.37	0.38
				Heating Rise (°F)	44	45	47	47	49	51	52	54	56	58
				Heating Rise (°C)	24	25	26	26	27	28	29	30	31	32
				CFM	1861	1822	1786	1758	1716	1688	1660	1619	1583	1539
				WATTS	400	417	426	441	452	467	482	492	507	519
Med-High	Orange	BHP	0.43	0.45	0.46	0.47	0.48	0.50	0.52	0.53	0.54	0.56		
		Heating Rise (°F)	37	37	38	39	40	40	41	42	43	44		
		Heating Rise (°C)	20	21	21	21	22	22	23	23	24	25		
		CFM	2319	2291	2255	2230	2193	2166	2118	2057	1992	1887		
		WATTS	758	769	787	799	808	823	822	805	780	737		
		BHP	0.81	0.82	0.84	0.86	0.87	0.88	0.88	0.86	0.84	0.79		
High	Black	Heating Rise (°F)	NA	NA	NA	NA	NA	NA	NA	NA	NA	NA	NA	
		Heating Rise (°C)	NA	NA	NA	NA	NA	NA	NA	NA	NA	NA	NA	
		CFM	2532	2487	2444	2391	2330	2259	2179	2111	2033	1949		
		WATTS	1014	1022	1015	994	965	935	898	858	823	786		
		BHP	1.09	1.10	1.09	1.07	1.03	1.00	0.96	0.92	0.88	0.84		
		Heating Rise (°F)	NA	NA	NA	NA	NA	NA	NA	NA	NA	NA	NA	
Heating Rise (°C)	NA	NA	NA	NA	NA	NA	NA	NA	NA	NA	NA			

Dry Coil Air Delivery - Downflow Discharge

UNIT	HEATING RISE RANGE	MOTOR SPEED	WIRE COLOR	EXTERNAL STATIC PRESSURE (IN. W.C.)										
				0.1	0.2	0.3	0.4	0.5	0.6	0.7	0.8	0.9	1.0	
48ES(-.N)A48130	35 - 65°F (19 - 36°C)	Low ¹	Blue	CFM	1503	1457	1423	1374	1330	1287	1241	1199	1153	1111
				WATTS	225	233	246	254	269	282	292	307	314	329
				BHP	0.24	0.25	0.26	0.27	0.29	0.30	0.31	0.33	0.34	0.35
				Heating Rise (°F)	45	47	48	49	51	53	55	57	59	61
				Heating Rise (°C)	25	26	27	27	28	29	30	32	33	34
				CFM	1556	1508	1461	1432	1388	1346	1302	1256	1221	1168
		WATTS	244	261	268	281	290	305	319	330	345	353		
		BHP	0.26	0.28	0.29	0.30	0.31	0.33	0.34	0.35	0.37	0.38		
		Heating Rise (°F)	44	45	47	47	49	51	52	54	56	58		
		Heating Rise (°C)	24	25	26	26	27	28	29	30	31	32		
		CFM	1861	1822	1786	1758	1716	1688	1660	1619	1583	1539		
		WATTS	400	417	426	441	452	467	482	492	507	519		
BHP	0.43	0.45	0.46	0.47	0.48	0.50	0.52	0.53	0.54	0.56				
Heating Rise (°F)	37	37	38	39	40	40	41	42	43	44				
Heating Rise (°C)	20	21	21	21	22	22	23	23	24	25				
CFM	2319	2291	2255	2230	2193	2166	2118	2057	1992	1887				
WATTS	758	769	787	799	808	823	822	805	780	737				
BHP	0.81	0.82	0.84	0.86	0.87	0.88	0.88	0.86	0.84	0.79				
Heating Rise (°F)	NA	NA	NA	NA	NA	NA	NA	NA	NA	36				
Heating Rise (°C)	NA	NA	NA	NA	NA	NA	NA	NA	NA	20				
CFM	2532	2487	2444	2391	2330	2259	2179	2111	2033	1949				
WATTS	1014	1022	1015	994	965	935	898	858	823	786				
BHP	1.09	1.10	1.09	1.07	1.03	1.00	0.96	0.92	0.88	0.84				
Heating Rise (°F)	NA	NA	NA	NA	NA	NA	NA	NA	NA	35				
Heating Rise (°C)	NA	NA	NA	NA	NA	NA	NA	NA	NA	19				

Dry Coil Air Delivery - Downflow Discharge

UNIT	HEATING RISE RANGE	MOTOR SPEED	WIRE COLOR	EXTERNAL STATIC PRESSURE (IN. W.C.)										
				0.1	0.2	0.3	0.4	0.5	0.6	0.7	0.8	0.9	1.0	
48ES(-,N)A60090	35 - 65°F (19 - 36°C)	Low ¹	Blue	CFM	1479	1436	1387	1346	1298	1253	1206	1160	1114	1061
				WATTS	224	239	247	262	270	284	300	319	330	
				BHP	0.24	0.26	0.26	0.28	0.29	0.30	0.32	0.33	0.34	0.35
				Heating Rise (°F)	46	47	49	51	52	54	56	59	NA	NA
				Heating Rise (°C)	26	26	27	28	29	30	31	33	NA	NA
				CFM	1841	1796	1761	1724	1690	1651	1616	1578	1527	1478
		WATTS	425	434	453	460	476	485	501	508	525	542		
		BHP	0.46	0.47	0.49	0.49	0.51	0.52	0.54	0.54	0.56	0.58		
		Heating Rise (°F)	37	38	39	39	40	41	42	43	45	46		
		Heating Rise (°C)	21	21	21	22	22	23	23	24	25	26		
		CFM	1944	1913	1872	1838	1801	1771	1731	1698	1655	1613		
		WATTS	486	501	511	529	537	554	565	578	595	603		
BHP	0.52	0.54	0.55	0.57	0.58	0.59	0.61	0.62	0.64	0.65				
Heating Rise (°F)	35	36	36	37	38	38	39	40	41	42				
Heating Rise (°C)	19	20	20	21	21	21	22	22	23	23				
CFM	2178	2148	2105	2073	2036	2002	1967	1919	1845	1751				
WATTS	674	691	703	717	733	743	758	754	734	701				
BHP	0.72	0.74	0.75	0.77	0.79	0.80	0.81	0.81	0.79	0.75				
Heating Rise (°F)	NA	NA	NA	NA	NA	34	35	35	37	39				
Heating Rise (°C)	NA	NA	NA	NA	NA	19	19	20	20	22				
CFM	2480	2432	2375	2322	2236	2161	2085	2006	1917	1808				
WATTS	1029	1012	995	975	941	908	869	836	796	751				
BHP	1.10	1.09	1.07	1.05	1.01	0.97	0.93	0.90	0.85	0.81				
Heating Rise (°F)	NA	NA	NA	NA	NA	NA	NA	34	35	38				
Heating Rise (°C)	NA	NA	NA	NA	NA	NA	NA	19	20	21				

Dry Coil Air Delivery - Downflow Discharge

UNIT	HEATING RISE RANGE	MOTOR SPEED	WIRE COLOR	EXTERNAL STATIC PRESSURE (IN. W.C.)										
				0.1	0.2	0.3	0.4	0.5	0.6	0.7	0.8	0.9	1.0	
48ES(-,N)A60115	30 - 60°F (17 - 33°C)	Low ¹	Blue	CFM	1479	1436	1387	1346	1298	1253	1206	1160	1114	1061
				WATTS	224	239	247	262	270	284	300	319	330	
				BHP	0.24	0.26	0.26	0.28	0.29	0.30	0.32	0.33	0.34	0.35
				Heating Rise (°F)	46	47	49	51	52	54	56	59	NA	NA
				Heating Rise (°C)	26	26	27	28	29	30	31	33	NA	NA
				CFM	1841	1796	1761	1724	1690	1651	1616	1578	1527	1478
		WATTS	425	434	453	460	476	485	501	508	525	542		
		BHP	0.46	0.47	0.49	0.49	0.51	0.52	0.54	0.54	0.56	0.58		
		Heating Rise (°F)	37	38	39	39	40	41	42	43	45	46		
		Heating Rise (°C)	21	21	21	22	22	23	23	24	25	26		
		CFM	1944	1913	1872	1838	1801	1771	1731	1698	1655	1613		
		WATTS	486	501	511	529	537	554	565	578	595	603		
BHP	0.52	0.54	0.55	0.57	0.58	0.59	0.61	0.62	0.64	0.65				
Heating Rise (°F)	35	36	36	37	38	38	39	40	41	42				
Heating Rise (°C)	19	20	20	21	21	21	22	22	23	23				
CFM	2178	2148	2105	2073	2036	2002	1967	1919	1845	1751				
WATTS	674	691	703	717	733	743	758	754	734	701				
BHP	0.72	0.74	0.75	0.77	0.79	0.80	0.81	0.81	0.79	0.75				
Heating Rise (°F)	NA	NA	NA	NA	NA	34	35	35	37	39				
Heating Rise (°C)	NA	NA	NA	NA	NA	19	19	20	20	22				
CFM	2480	2432	2375	2322	2236	2161	2085	2006	1917	1808				
WATTS	1029	1012	995	975	941	908	869	836	796	751				
BHP	1.10	1.09	1.07	1.05	1.01	0.97	0.93	0.90	0.85	0.81				
Heating Rise (°F)	NA	NA	NA	NA	NA	NA	NA	34	35	38				
Heating Rise (°C)	NA	NA	NA	NA	NA	NA	NA	19	20	21				

Dry Coil Air Delivery - Downflow Discharge

UNIT	HEATING RISE RANGE	MOTOR SPEED	WIRE COLOR	EXTERNAL STATIC PRESSURE (IN. W.C.)										
				0.1	0.2	0.3	0.4	0.5	0.6	0.7	0.8	0.9	1.0	
48ES(-,N)A60130	35 - 65°F (19 - 36°C)	Low ¹	Blue	CFM	1479	1436	1387	1346	1298	1253	1206	1160	1114	1061
				WATTS	224	239	247	262	270	284	300	307	319	330
				BHP	0.24	0.26	0.26	0.28	0.29	0.30	0.32	0.33	0.34	0.35
				Heating Rise (°F)	46	47	49	51	52	54	56	59	NA	NA
				Heating Rise (°C)	26	26	27	28	29	30	31	33	NA	NA
				CFM	1841	1796	1761	1724	1690	1651	1616	1578	1527	1478
	Med-Low	Pink	WATTS	425	434	453	460	476	485	501	508	525	542	
			BHP	0.46	0.47	0.49	0.49	0.51	0.52	0.54	0.54	0.56	0.58	
			Heating Rise (°F)	37	38	39	39	40	41	42	43	45	46	
			Heating Rise (°C)	21	21	21	22	22	23	23	24	25	26	
			CFM	1944	1913	1872	1838	1801	1771	1731	1698	1655	1613	
			WATTS	486	501	511	529	537	554	565	578	595	603	
Med-High	Orange	BHP	0.52	0.54	0.55	0.57	0.58	0.59	0.61	0.62	0.64	0.65		
		Heating Rise (°F)	35	36	36	37	38	38	39	40	41	42		
		Heating Rise (°C)	19	20	20	21	21	21	22	22	23	23		
		CFM	2178	2148	2105	2073	2036	2002	1967	1919	1845	1751		
		WATTS	674	691	703	717	733	743	758	754	734	701		
		BHP	0.72	0.74	0.75	0.77	0.79	0.80	0.81	0.81	0.79	0.75		
High	Black	Heating Rise (°F)	NA	NA	NA	NA	NA	34	35	37	39			
		Heating Rise (°C)	NA	NA	NA	NA	NA	19	20	20	22			
		CFM	2480	2432	2375	2322	2236	2161	2085	2006	1917	1808		
		WATTS	1029	1012	995	975	941	908	869	836	796	751		
		BHP	1.10	1.09	1.07	1.05	1.01	0.97	0.93	0.90	0.85	0.81		
		Heating Rise (°F)	NA	NA	NA	NA	NA	NA	NA	34	35	38		
Heating Rise (°C)	NA	NA	NA	NA	NA	NA	NA	19	20	21				

*Air delivery values are without air filter and are for dry coil (See 48ES Wet Coil Pressure Drop table).

¹ Factory-shipped heating speed.

² Factory-shipped cooling speed

"NA" = Not allowed for heating speed

NOTE: Deduct field-supplied air filter pressure drop and wet coil pressure drop to obtain external static pressure available for ducting. Shaded areas indicate speed/static combinations that are not permitted for dehumidification speed.

Wet Coil Pressure Drop (IN. W.C.)

UNIT SIZE	STANDARD CFM (SCFM)																
	600	700	800	900	1000	1100	1200	1300	1400	1500	1600	1700	1800	1900	2000	2100	2200
24	0.03	0.04	0.04	0.05	0.06												
30				0.05	0.06	0.07	0.08	0.11									
36				0.06	0.06	0.09	0.10	0.11	0.14								
42					0.05	0.05	0.06	0.07	0.08	0.08	0.09	0.09	0.11				
48							0.04	0.06	0.09	0.10	0.10	0.11	0.12	0.13	0.14		
60									0.06	0.06	0.07	0.01	0.08	0.09	0.10	0.12	0.13

Economizer with 1-in. Filter Pressure Drop (IN. W.C.)

FILTER SIZE IN. (MM)	COOLING TONS	STANDARD CFM (SCFM)																
		600	700	800	900	1000	1100	1200	1300	1400	1500	1600	1700	1800	1900	2000	2100	2200
600-1400 CFM 12x20x1+12x20x1 (305x508x25+305x508x25)	2.0,	-	-	0.09	0.14	0.16	0.18	0.25	0.28	0.3	-	-	-	-	-	-	-	-
	2.5,																	
	3.0																	
1200-1800 CFM 16x24x1+14x24x1 (406x610x25+356x610x25)	3.5,	-	-	-	-	-	-	0.10	0.11	0.12	0.13	0.14	0.16	0.16	-	-	-	-
	4.0																	
1500-2200 CFM 16x24x1+18x24x1 (406x610x25+457x610x25)	5.0	-	-	-	-	-	-	-	-	-	0.15	0.17	0.18	0.20	0.21	0.22	0.23	0.23

Filter Pressure Drop Table (IN. W.C.)

FILTER SIZE IN. (MM)	COOLING TONS	STANDARD CFM (SCFM)																
		600	700	800	900	1000	1100	1200	1300	1400	1500	1600	1700	1800	1900	2000	2100	2200
600-1400 CFM 12x20x1+12x20x1 (305x508x25+305x508x25)	2.0,	0.03	0.05	0.06	0.08	0.10	0.11	0.13	0.14	0.16	-	-	-	-	-	-	-	-
	2.5,																	
	3.0																	
1200-1800 CFM 16x24x1+14x24x1 (406x610x25+356x610x25)	3.5,	-	-	-	-	-	-	0.07	0.08	0.09	0.09	0.10	0.11	0.12	-	-	-	-
	4.0																	
1500-2200 CFM 16x24x1+18x24x1 (406x610x25+457x610x25)	5.0	-	-	-	-	-	-	-	-	-	0.04	0.06	0.08	0.10	0.11	0.13	0.14	0.15

TYPICAL PIPING AND WIRING

48ES--A

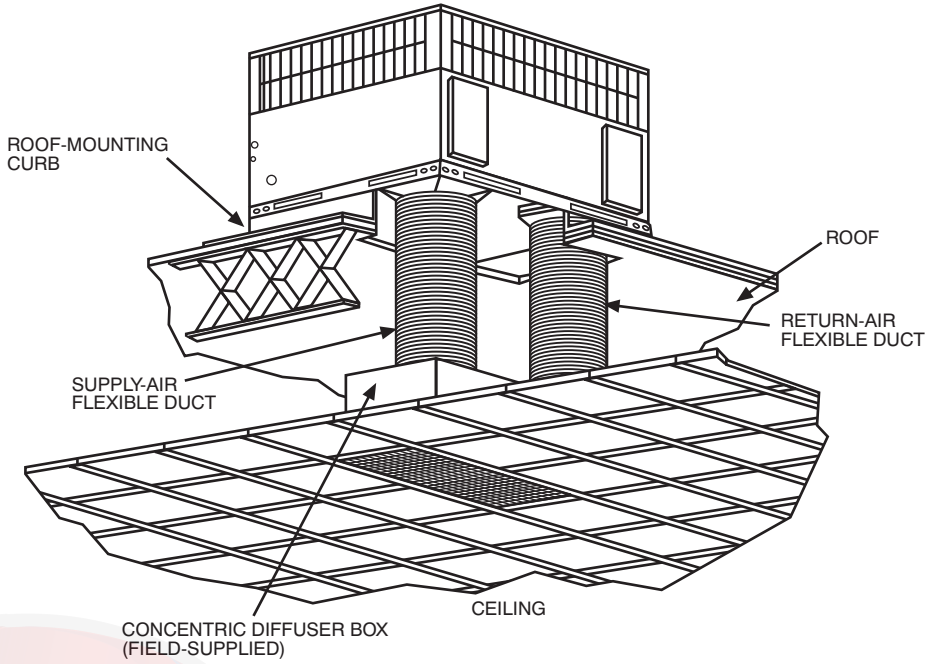

A09230

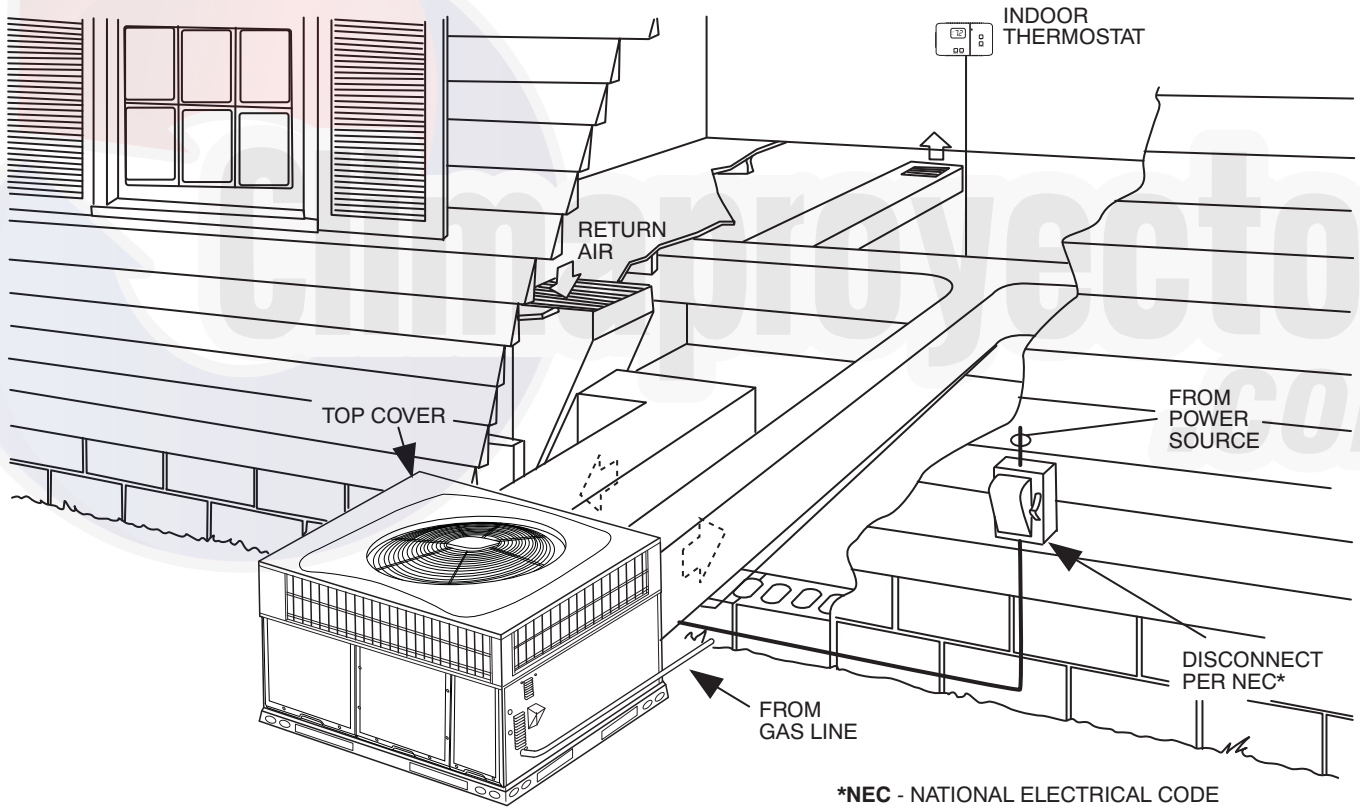

*NEC - NATIONAL ELECTRICAL CODE

A09231

APPLICATION DATA

Condensate trap — A 2-in. (51 mm) condensate trap must be field supplied.

Ductwork — Secure downflow discharge ductwork to roof curb. For horizontal discharge applications, attach ductwork to unit with flanges.

To convert a unit to downflow discharge — Units are equipped with factory-installed inserts in the down-flow openings. Removal of the inserts is similar to removing an electrical knock-out. Use the duct cover to seal the horizontal discharge openings in the unit. Units installed in horizontal discharge orientation do not require duct covers.

Airflow — Units are draw-thru in the cooling mode and blow-thru in the heating mode.

Maximum cooling airflow — To minimize the possibility of condensate blow-off from the evaporator, airflow through the units should not exceed 450 cfm per ton.

Minimum cooling airflow — Minimum cooling airflow is 350 cfm per ton.

Minimum ambient cooling operation temperature — All standard units have a minimum ambient operating temperature of 40°F (4°C). With accessory low ambient temperature kit, units can operate at temperatures down to 0°F (-17°C).

Minimum temperature — Air entering the heat exchanger in heating mode must be a minimum of 50°F (10°C) continuous and/or 45°F (7°C) intermittent.



ELECTRICAL DATA

48ES--A

UNIT	NOMINAL V-PH-HZ	VOLTAGE RANGE		COMPRESSOR		OFM	IFM	IDM	POWER SUPPLY				
		MIN	MAX	RLA	LRA	FLA	FLA	FLA	MCA	MOCP**			
48ES(-,N)A24040	208/230-1-60	187	253	12.8	58.3	1.2	4.1	0.7	21.3	30.			
48ES(-,N)A24060				12.8	58.3	1.2	4.1	1.7	21.3	30.			
48ES(-,N)A30040				12.8	64.0	1.2	4.1	0.7	21.3	30.			
48ES(-,N)A30060				12.8	64.0	1.2	4.1	1.7	21.3	30.			
48ES(-,N)A36060				16.7	79.0	1.2	6.0	1.7	28.0	40.			
48ES(-,N)A36090				16.7	79.0	1.2	6.0	0.5	28.0	40.			
48ES(-,N)A42060				17.9	112.0	1.2	6.0	1.7	29.6	40.			
48ES(-,N)A42090				17.9	112.0	1.2	6.0	0.7	29.6	40.			
48ES(-,N)A48090				21.8	117.0	1.2	7.6	0.7	36.0	50.			
48ES(-,N)A48115				21.8	117.0	1.2	7.6	1.7	36.0	50.			
48ES(-,N)A48130				21.8	117.0	1.2	7.6	0.5	36.0	50.			
48ES(-,N)A60090				26.4	134.0	1.2	7.6	0.7	41.8	60.			
48ES(-,N)A60115				26.4	134.0	1.2	7.6	1.7	41.8	60.			
48ES(-,N)A60130				26.4	134.0	1.2	7.6	0.5	41.8	60.			
48ES(-,N)A30040				208/230-3-60	187	253	8.4	58.0	1.2	4.1	0.7	15.8	20.
48ES(-,N)A30060	8.4	58.0	1.2				4.1	1.7	15.8	20.			
48ES(-,N)A36060	10.4	88.0	1.2				6.0	1.7	20.3	30.			
48ES(-,N)A36090	10.4	88.0	1.2				6.0	0.5	20.3	30.			
48ES(-,N)A42060	13.5	88.0	1.2				6.0	1.7	24.1	35.			
48ES(-,N)A42090	13.5	88.0	1.2				6.0	0.7	24.1	35.			
48ES(-,N)A48090	13.7	83.1	1.2				7.6	0.7	25.9	35.			
48ES(-,N)A48115	13.7	83.1	1.2				7.6	1.7	25.9	35.			
48ES(-,N)A48130	13.7	83.1	1.2				7.6	0.5	25.9	35.			
48ES(-,N)A60090	16.0	110.0	1.2				7.6	0.7	28.8	40.			
48ES(-,N)A60115	16.0	110.0	1.2				7.6	1.7	28.8	40.			
48ES(-,N)A60130	16.0	110.0	1.2				7.6	0.5	28.8	40.			
48ES(-,N)A36060	460-3-60	414	506				5.8	38.0	0.5	3.0	0.7	10.7	15.
48ES(-,N)A36090							5.8	38.0	0.5	3.0	0.3	10.7	15.
48ES(-,N)A42060							6.0	44.0	0.5	3.0	0.7	11.0	15.
48ES(-,N)A42090				6.0	44.0	0.5	3.0	0.3	11.0	15.			
48ES(-,N)A48090				6.2	41.0	0.5	3.8	0.3	12.1	15.			
48ES(-,N)A48115				6.2	41.0	0.5	3.8	0.7	12.1	15.			
48ES(-,N)A48130				6.2	41.0	0.5	3.8	0.3	12.1	15.			
48ES(-,N)A60090				7.8	52.0	0.5	3.8	0.3	14.3	20.			
48ES(-,N)A60115				7.8	52.0	0.5	3.8	0.7	14.0	20.			
48ES(-,N)A60130				7.8	52.0	0.5	3.8	0.3	14.0	20.			

** FUSE OR CIRCUIT BREAKER

Note: 460 volt units have 230 volt ID motors with FLA values at 230 volts

LEGEND

- FLA - Full Load Amps
- IDM - Inducer Motor
- IFM - Indoor Fan Motor
- LRA - Locked Rotor Amps
- MCA - Minimum Circuit Amps
- MOCP - Maximum Over Current Protection
- OFM - Outdoor Fan Motor
- RLA - Rated Load Amps

NOTES:

- In compliance with NEC (National Electrical Code) requirements for multimotor and combination load equipment (refer to NEC Articles 430 and 440), the overcurrent protective device for the unit shall be Power Supply fuse or circuit breaker.
- Minimum wire size is based on 60 C copper wire. If other than 60 C wire is used, or if length exceeds wire length in table, determine size from NEC.
- Unbalanced 3-Phase Supply Voltage
Never operate a motor where a phase imbalance in supply voltage is greater than 2%. Use the following formula to determine the percentage of voltage imbalance

$$\% \text{ Voltage imbalance} = 100 \times \frac{\text{max voltage deviation from average voltage}}{\text{average voltage}}$$

EXAMPLE: Supply voltage is 230-3-60.

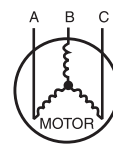

AB = 228 v
BC = 231 v
AC = 227 v

$$\begin{aligned} \text{Average Voltage} &= \frac{228 + 231 + 227}{3} \\ &= \frac{686}{3} \\ &= 229 \end{aligned}$$

Determine maximum deviation from average voltage.

(AB) 229 - 228 = 1 v
(BC) 231 - 229 = 2 v
(AC) 229 - 227 = 2 v

Maximum deviation is 2 v.

Determine percent of voltage imbalance

$$\begin{aligned} \% \text{ Voltage Imbalance} &= 100 \times \frac{2}{229} \\ &= 0.8\% \end{aligned}$$

This amount of phase imbalance is satisfactory as it is below the maximum allowable 2%.

IMPORTANT: If the supply voltage phase imbalance is more than 2%, contact your local electric utility company immediately.

A06564

CONNECTION WIRING SCHEMATIC 208/230-1-60

CONNECTION WIRING DIAGRAM

DANGER: ELECTRICAL SHOCK HAZARD DISCONNECT POWER BEFORE SERVICING

NOTES:

- IF ANY OF THE ORIGINAL WIRES FURNISHED ARE REPLACED, THEY MUST BE REPLACED WITH TYPE 90 DEG. C WIRE OR ITS EQUIVALENT.
- SEE PRICE PAGES FOR THERMOSTAT AND SUBBASES.
- USE 75 DEG. COPPER CONDUCTORS FOR FIELD INSTALLATION.
- SEE INSTALLATION INSTRUCTIONS FOR PROPER HEATING AND COOLING CONNECTIONS FOR YOUR UNIT. INDOOR FAN MOTOR PLUGS - "DO NOT DISCONNECT UNDER LOAD"
- ON SMALL BASE MODELS LS1 AND LS2 ARE WIRED IN SERIES. LARGE BASE MODELS HAVE LS1 ONLY.
- INDUCER CAPACITOR AND WIRING ON CERTAIN MODELS ONLY. IF CAP2 IS PRESENT, YELLOW WIRES FROM IGC AND IDM CONNECT ON SAME SIDE OF CAP2.
- THIS FUSE IS MANUFACTURED BY LITTELFUSE, P/N 257003.
- THIS FUSE IS MANUFACTURED BY LITTELFUSE, P/N 257005.

SCHEMATIC 208/230-1-60

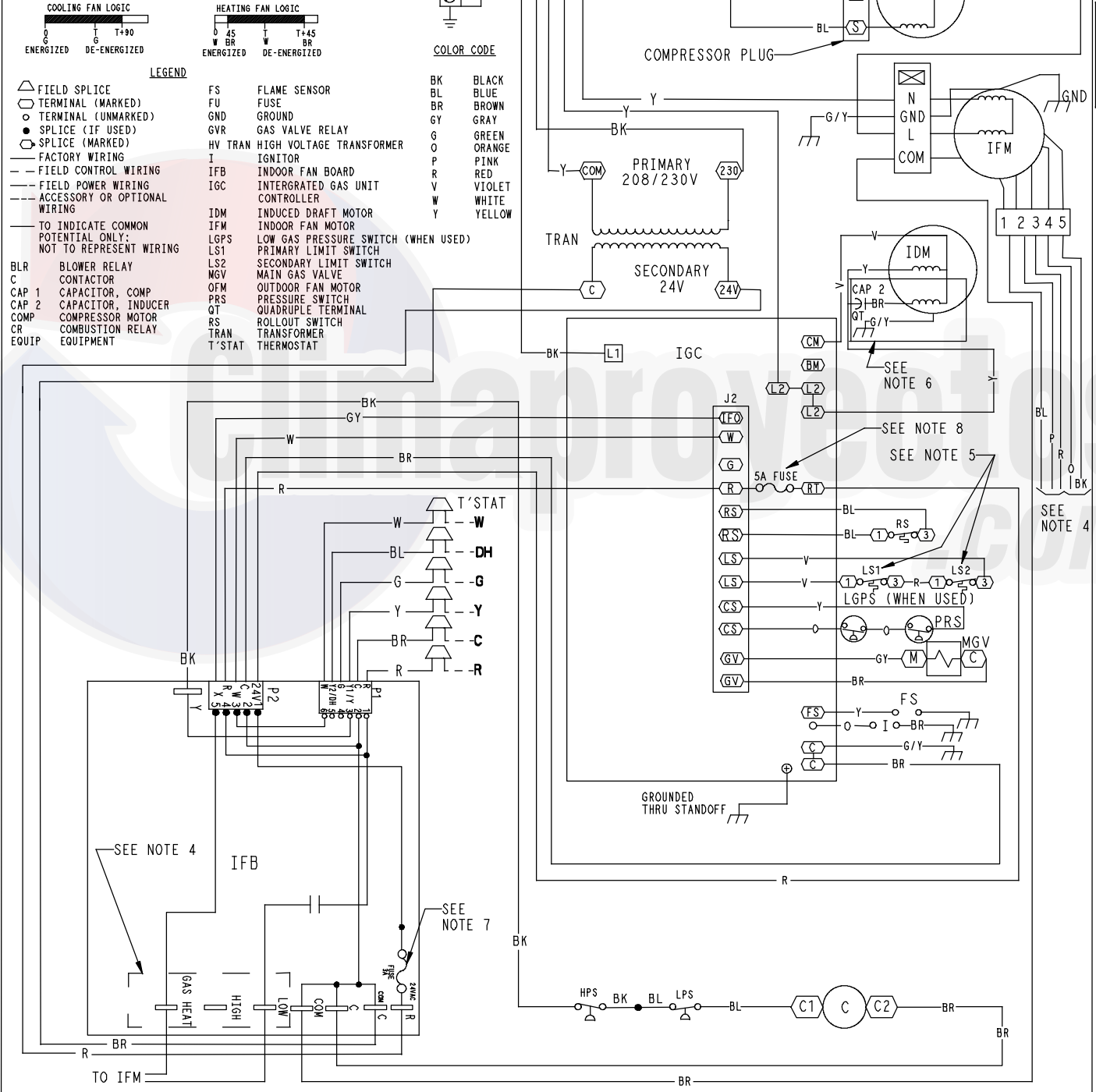

48ES--A

LADDER WIRING DIAGRAM

DANGER: ELECTRICAL SHOCK HAZARD DISCONNECT POWER BEFORE SERVICING

48ES--A

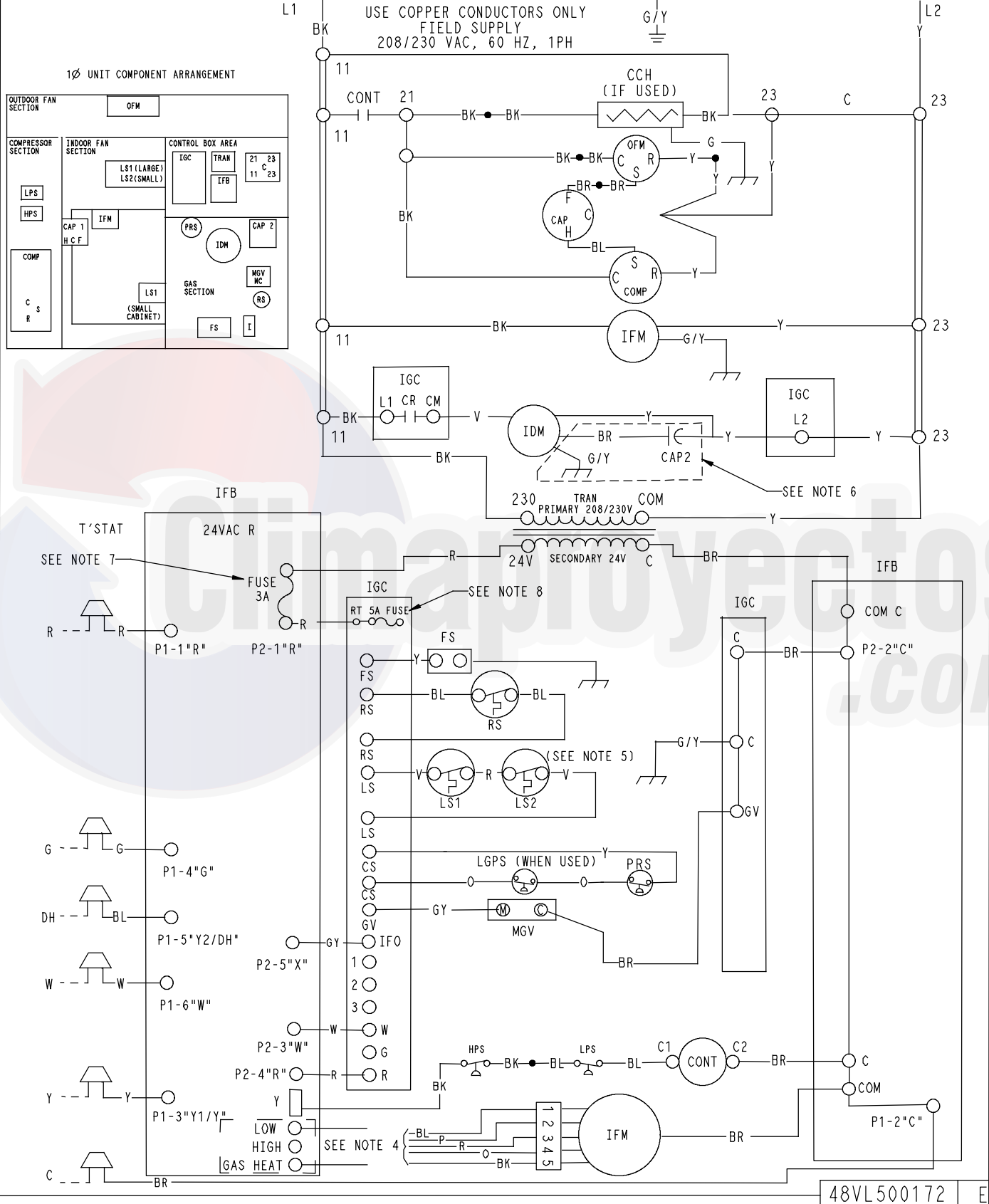

48VL500172 E

CONNECTION WIRING SCHEMATIC 208/230-3-60

CONNECTION WIRING DIAGRAM

DANGER: ELECTRICAL SHOCK HAZARD DISCONNECT POWER BEFORE SERVICING

NOTES:

- IF ANY OF THE ORIGINAL WIRES FURNISHED ARE REPLACED, THEY MUST BE REPLACED WITH TYPE 90 DEG. C WIRE OR ITS EQUIVALENT.
- SEE PRICE PAGES FOR THERMOSTAT AND SUBBASES.
- USE 75 DEG. COPPER CONDUCTORS FOR FIELD INSTALLATION.
- SEE INSTALLATION INSTRUCTIONS FOR PROPER HEATING AND COOLING CONNECTIONS FOR YOUR UNIT. INDOOR FAN MOTOR PLUGS - "DO NOT DISCONNECT UNDER LOAD"
- LS2 USED ON SMALL CHASSIS ONLY.
- INDUCER CAPACITOR AND WIRING ON CERTAIN MODELS ONLY. IF CAP2 IS PRESENT, YELLOW WIRES FROM IGC AND IDM CONNECT ON SAME SIDE OF CAP2.
- THIS FUSE IS MANUFACTURED BY LITTELFUSE, P/N 257003.
- THIS FUSE IS MANUFACTURED BY LITTELFUSE, P/N 257005.
- DEHUMIDIFICATION FEATURE CANNOT BE USED WHEN ECONOMIZER IS INSTALLED.

SCHEMATIC 208/230-3-60

COLOR CODE

BK	BLACK
BL	BLUE
BR	BROWN
GY	GRAY
G	GREEN
O	ORANGE
P	PINK
R	RED
V	VIOLET
W	WHITE
Y	YELLOW

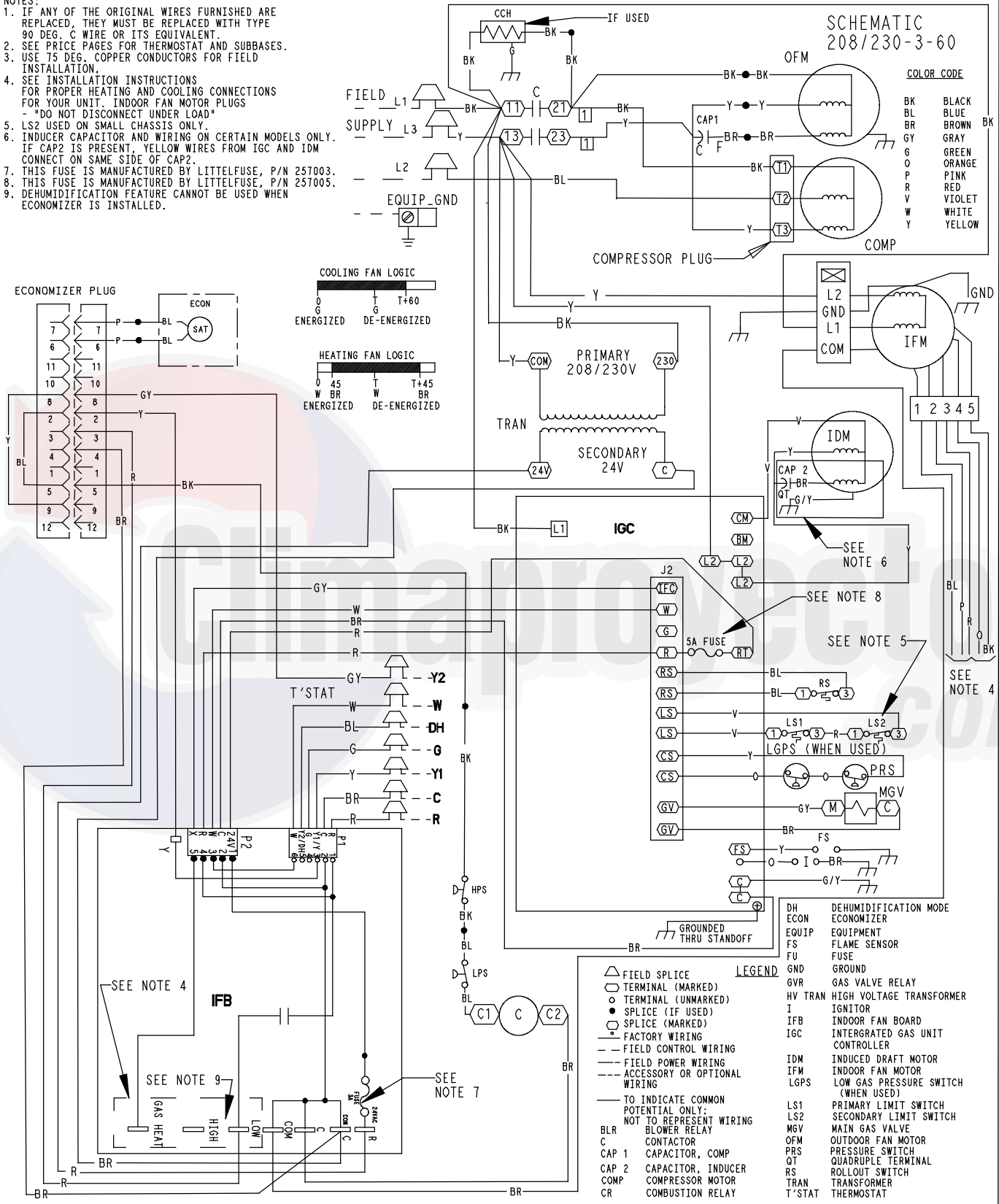

48ES--A

LADDER WIRING DIAGRAM

DANGER: ELECTRICAL SHOCK HAZARD DISCONNECT POWER BEFORE SERVICING

48ES--A

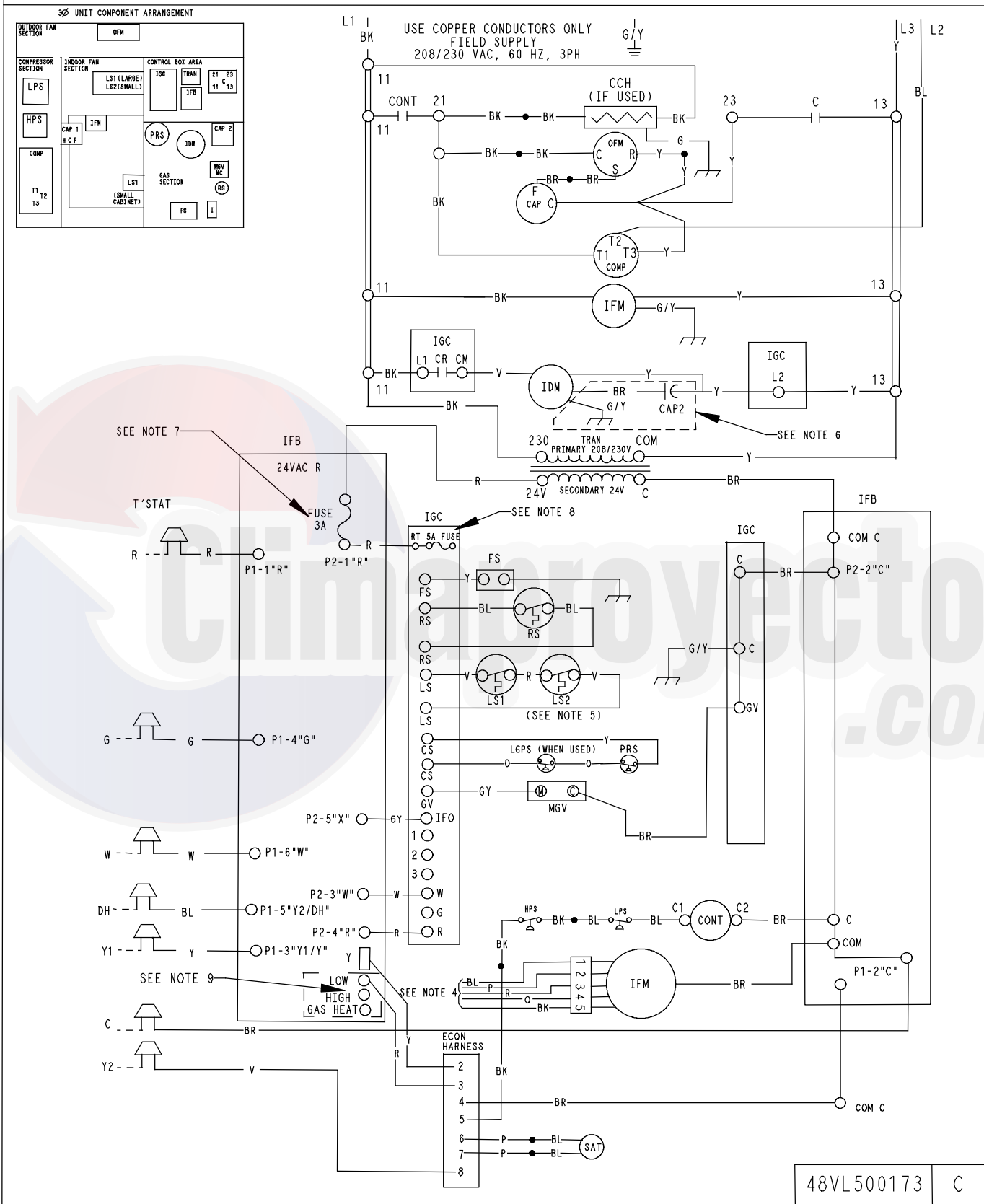

48VL500173 C

CONNECTION WIRING SCHEMATIC 460-3-60

CONNECTION WIRING DIAGRAM

DANGER: ELECTRICAL SHOCK HAZARD DISCONNECT POWER BEFORE SERVICING

NOTES:

1. IF ANY OF THE ORIGINAL WIRES FURNISHED ARE REPLACED, THEY MUST BE REPLACED WITH TYPE 90 DEG. C WIRE OR ITS EQUIVALENT.
2. SEE PRICE PAGES FOR THERMOSTAT AND SUBBASES.
3. USE 75 DEG. COPPER CONDUCTORS FOR FIELD INSTALLATION.
4. SEE INSTALLATION INSTRUCTIONS FOR PROPER HEATING AND COOLING CONNECTIONS FOR YOUR UNIT. INDOOR FAN MOTOR PLUGS - "DO NOT DISCONNECT UNDER LOAD"
5. LS2 USED ON SMALL CHASSIS ONLY.
6. INDUCER CAPACITOR AND WIRING ON CERTAIN MODELS ONLY. IF CAP2 IS PRESENT, YELLOW WIRES FROM CONTACTOR AND IDM CONNECT ON SAME SIDE OF CAP2.
7. THIS FUSE IS MANUFACTURED BY LITTELFUSE, P/N 257003.
8. THIS FUSE IS MANUFACTURED BY LITTELFUSE, P/N 257005.
9. THESE FUSES ARE MANUFACTURED BY COOPER BUSSMAN, P/N FMO-R-5.
10. DEHUMIDIFICATION FEATURE CANNOT BE USED WHEN ECONOMIZER IS INSTALLED.

SCHMATIC 460-3-60

COLOR CODE

BK	BLACK
BL	BLUE
BR	BROWN
GY	GRAY
G	GREEN
O	ORANGE
P	PINK
R	RED
V	VIOLET
W	WHITE
Y	YELLOW

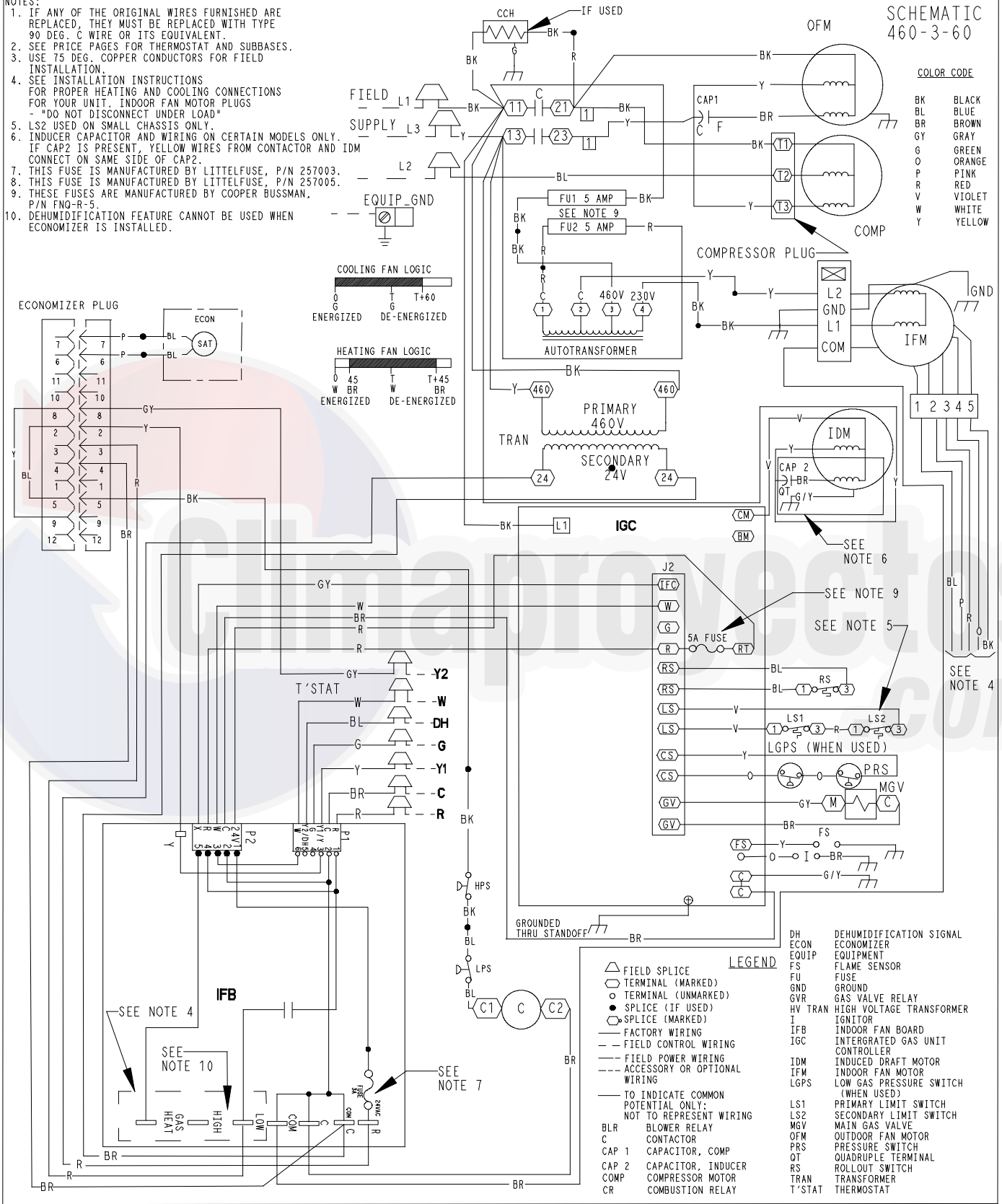

48ES--A

LEGEND

△	FIELD SPLICE
○	TERMINAL (MARKED)
○	TERMINAL (UNMARKED)
●	SPLICE (IF USED)
○	SPLICE (MARKED)
---	FACTORY WIRING
- - -	FIELD CONTROL WIRING
- · - · -	FIELD POWER WIRING
- · - · -	ACCESSORY OR OPTIONAL WIRING
---	TO INDICATE COMMON POTENTIAL ONLY; NOT TO REPRESENT WIRING
BLR	BLOWER RELAY
C	CONTACTOR
CAP 1	CAPACITOR, COMP
CAP 2	CAPACITOR, INDUCER
COMP	COMPRESSOR MOTOR
CR	COMBUSTION RELAY
DH	DEHUMIDIFICATION SIGNAL
ECON	ECONOMIZER
EQUIP	EQUIPMENT
FS	FLAME SENSOR
FU	FUSE
GND	GROUND
GVR	GAS VALVE RELAY
HV TRAN	HIGH VOLTAGE TRANSFORMER
I	IGNITER
IFB	INDOOR FAN BOARD
IGC	INTERGRATED GAS UNIT CONTROLLER
IDM	INDUCED DRAFT MOTOR
IFM	INDOOR FAN MOTOR
LGPS	LOW GAS PRESSURE SWITCH (WHEN USED)
LS1	PRIMARY LIMIT SWITCH
LS2	SECONDARY LIMIT SWITCH
MGV	MAIN GAS VALVE
OFM	OUTDOOR FAN MOTOR
PRS	PRESSURE SWITCH
QT	QUADRUPLE TERMINAL
RS	ROLLOUT SWITCH
TRAN	TRANSFORMER
T' STAT	THERMOSTAT

A09265

LADDER WIRING SCHEMATIC 460-3-60

LADDER WIRING DIAGRAM

DANGER: ELECTRICAL SHOCK HAZARD DISCONNECT POWER BEFORE SERVICING

30 UNIT COMPONENT ARRANGEMENT

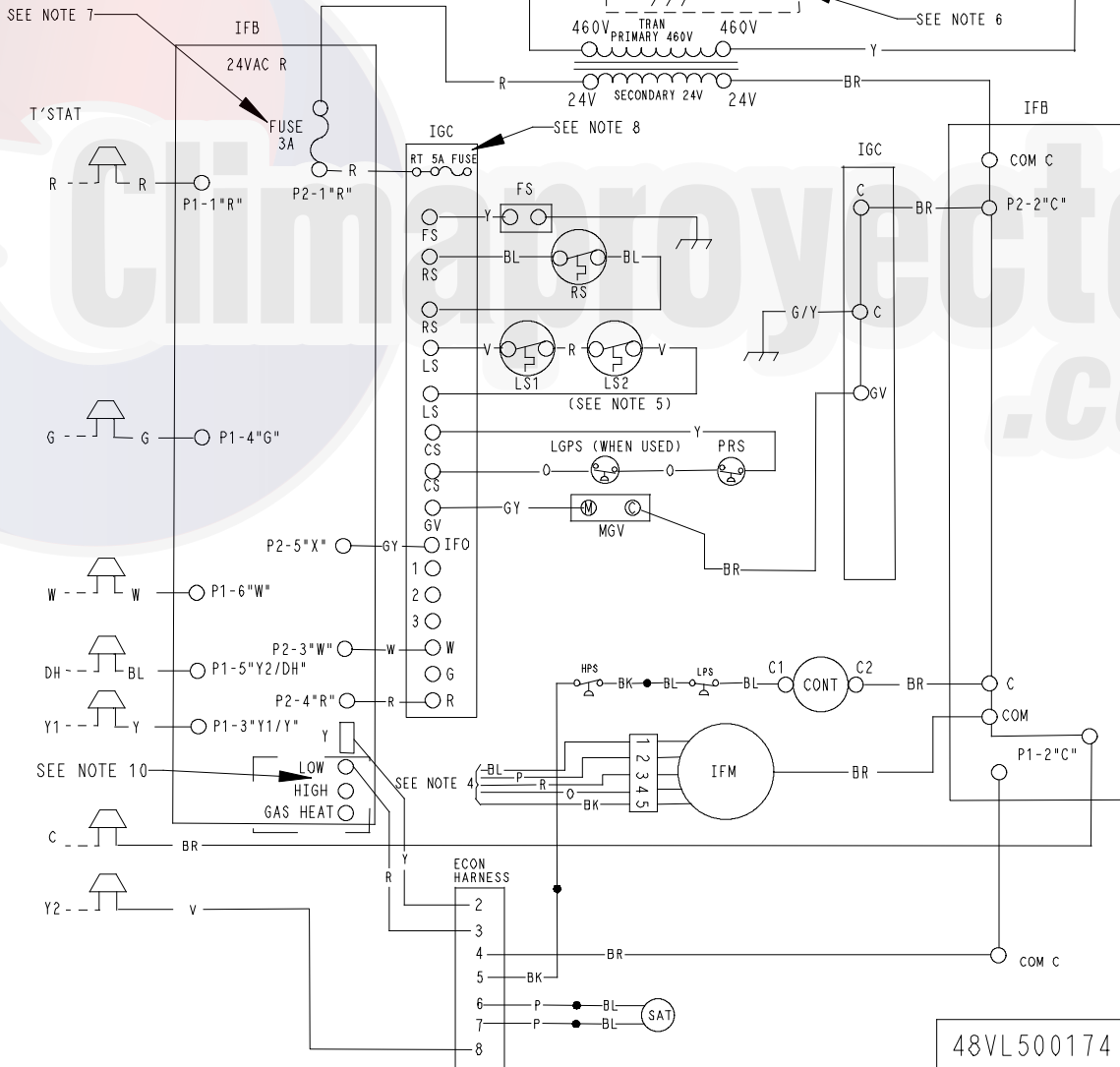
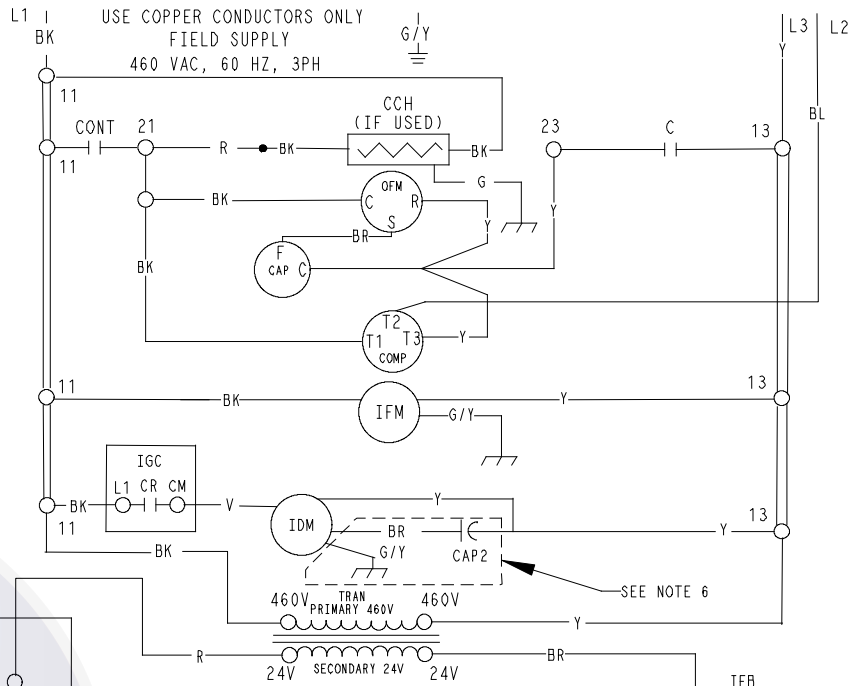
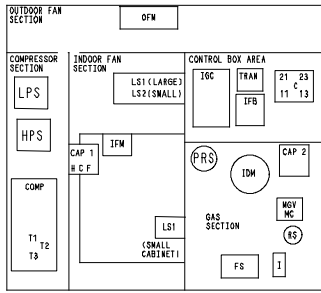

48VL500174

C

A09265

48ES--A

CONTROLS

Operating sequence

Heating - On a call for heating, terminal “W” of the thermostat is energized, starting the induced-draft motor. When the pressure switch senses that the induced-draft motor is moving sufficient combustion air, the burner sequence begins. This function is performed by the integrated gas unit controller (IGC). The indoor (evaporator)-fan motor is energized 45 sec after flame is established. When the thermostat is satisfied and W is de-energized, the burners stop firing and the indoor (evaporator) fan motor shuts off after a 45-sec time-off delay. Please note that the IGC has the capability to automatically reduce the indoor fan motor on delay and increase the indoor fan motor off delay in the event of high duct static and/or partially-clogged filter.

Cooling — When the system thermostat calls for cooling, 24 V is supplied to the “Y1/Y” and “G” terminals of the thermostat. This completes the circuit to the contactor coil (C) and indoor (evaporator) fan relay (IFR). The normally open contacts of energized C close and complete the circuit through compressor motor (COMP) to outdoor (condenser) fan motor (OFM). Both motors start instantly. The set of normally open contacts of energized IFR close and complete the circuit through IFM. The IFM starts instantly.

On the loss of the thermostat call for cooling, 24 V is removed from both the “Y1/Y” and “G” terminals (provided the fan switch is in the “AUTO” position) de-energizing the compressor contactor and opening the contacts supplying power to compressor/OFM. After a 90-second delay, the IFM shuts off. If the thermostat fan selector switch is in the “ON” position, the IFM will run continuously.

NOTE: On units with a Time Guard® II device: Once the compressor has started and then stopped, it cannot be restarted again until 5 minutes have elapsed.

Climaproyectos
.com

GUIDE SPECIFICATIONS

Packaged Gas Heating/Electric Cooling Units Constant Volume Application

HVAC Guide Specifications

Size Range: **2 to 5 Tons, Nominal Cooling
40,000 to 130,000 Btuh,
Nominal Heating Input**

Model Number: 48ES-A

Part 1 — General

SYSTEM DESCRIPTION

Outdoor rooftop mounted, gas heating/electric cooling unit utilizing a hermetic scroll compressor for cooling duty. Unit shall discharge supply air vertically or horizontally as shown on contract drawings. Condenser fan/coil section shall have a draw-thru design with vertical discharge for minimum sound levels.

QUALITY ASSURANCE

- A. Unit shall be rated in accordance with AHRI Standards 210/240 and 270.
- B. Unit shall be designed in accordance with UL Standard 1995 and ANSI Z21.47.
- C. Unit shall be manufactured in a facility registered to ISO 9001 manufacturing quality standard.
- D. Unit shall be UL listed and c-UL certified as a total package for safety requirements.
- E. Roof curb shall be designed to conform to NRCA Standards.
- F. Insulation and adhesives shall meet NFPA 90.1 requirements for flame spread and smoke generation.
- G. Cabinet insulation shall meet ASHRAE Standard 62.2.

DELIVERY, STORAGE AND HANDLING

Unit shall be stored and handled per manufacturer's recommendations.

Part 2 — Products

EQUIPMENT

A. General:

Factory-assembled, single-piece, heating and cooling unit. Contained within the enclosure shall be all factory wiring, piping, controls, refrigerant charge with R-410A refrigerant, and special features required prior to field start-up.

B. Unit Cabinet:

1. Unit cabinet shall be constructed of phosphated, zinc-coated, pre-painted steel capable of with-standing 500 hours in salt spray.
2. Normal service shall be through multiple removable cabinet panels.
3. The unit shall be constructed on a rust proof unit base that has an externally trapped, integrated sloped drain.
4. Evaporator fan compartment top surface shall be insulated with a minimum 1/2-in. (12.7 mm) thick, flexible fiberglass insulation, coated on the air side and retained by adhesive and mechanical means. The evaporator wall sections will be insulated with a minimum semi-rigid foil-faced board capable of being wiped clean. Aluminum foil-faced fiberglass insulation shall be used in the entire indoor air cavity section.
5. Unit shall have a field-supplied condensate trap.

C. Fans:

1. The evaporator fan motor shall be a multi-speed, direct-drive, as shown on equipment drawings.
2. Fan wheel shall be made from steel, be double-inlet type with forward curved blades with corrosion resistant finish. Fan wheel shall be dynamically balanced.

3. Condenser fan shall be direct drive propeller type with aluminum blades riveted to corrosion resistant steel spiders, be dynamically balanced, and discharge air vertically.

D. Compressor:

1. Fully hermetic compressors with factory-installed vibration isolation.
2. Scroll compressors shall be standard on all units.

E. Coils:

Evaporator and condenser coils shall have aluminum plate fins mechanically bonded to seamless copper tubes with all joints brazed. Tube sheet openings shall be belled to prevent tube wear.

F. Heating Section:

1. Induced-draft combustion type with energy saving direct spark ignition system and redundant main gas valve.
2. Induced-draft motors shall provide adequate airflow for combustion.
3. The heat exchangers shall be constructed of aluminized steel for corrosion resistance.
4. Burners shall be of the in-shot type constructed of aluminum coated steel.
5. All gas piping and electric power shall enter the unit cabinet at a single location.

G. Refrigerant Components:

Refrigerant expansion device shall be of the TXV (thermostatic expansion valve) type.

H. Filters:

Filter section shall consist of field-installed, throwaway, 1-in. (25 mm) thick fiberglass filters of commercially available sizes.

I. Controls and Safeties:

1. Unit controls shall be complete with a self-contained low voltage control circuit.
2. Compressors shall incorporate a solid-state compressor protector that provides reset capability.

J. Operating Characteristics:

1. Unit shall be capable of starting and running at 125°F (51°C) ambient outdoor temperature per maximum load criteria of AHRI Standard 210.
2. Compressor with standard controls shall be capable of operation down to 40°F (4°C) ambient outdoor temperature.
3. Units shall be provided with fan time delay to prevent cold air delivery before the heat exchanger warms up.
4. Unit shall be provided with 90-second fan time delay after the thermostat is satisfied.

K. Electrical Requirements:

All unit power wiring shall enter the unit cabinet at a single location.

L. Motors:

1. Compressor motors shall be of the refrigerant-cooled type with line-break thermal and current overload protection.
2. All fan motors shall have permanently lubricated bearings, and inherent, automatic reset, thermal overload protection.
3. Condenser fan motor shall be totally enclosed.
4. Evaporator Fan Motor to be ECM Motor.

M. Low NOx:

Shall provide NOx reduction to values below 40 nanograms/joule to meet California's and other localities' emission requirements as shipped from factory.

GUIDE SPECIFICATIONS (CONT)

N. Compressor Protection:

Solid-state control shall protect compressor by preventing “short cycling.”

O. Special Features Available:

1. Coil Options

Base unit with tin plated indoor coil hairpins available as a factory installed option.

2. Compressor Start Kit (single phase units only):

Shall provide additional starting torque for single-phase compressors.

3. Thermostat:

To provide for one-stage heating and cooling in addition manual or automatic changeover and indoor fan control.

4. Crankcase Heater:

Shall provide anti-floodback protection for low-load cooling applications.

5. Economizer:

(Horizontal - Field installed accessory)

(Vertical - Field installed accessory or factory installed option)

a. Economizer controls capable of providing free cooling using outside air.

b. Equipped with low leakage dampers not to exceed 3% leakage, at 1.0 IN. W.C. pressure differential.

c. Spring return motor shuts off outdoor damper on power failure.

6. Filter Rack Kit:

Shall provide filter mounting for downflow applications. Offered as an accessory or as a factory installed option.

7. Flat Roof Curb:

Curbs shall have seal strip and a wood nailer for flashing and shall be installed per manufacturer’s instructions.

8. Flue Discharge Deflector

Directs flue gas exhaust 90 degrees upward from current discharge.

9. Heat Exchanger

Stainless Steel Heat Exchanger available as a factory installed option.

10. High Altitude Propane Conversion Kit:

Shall consist of all required hardware to convert to propane gas heat operation at 2001 to 6000 ft (611 to 1829 m) above sea level.

11. Low Ambient Package:

Shall consist of a solid-state control and condenser coil temperature sensor for controlling condenser-fan motor operation, which shall allow unit to operate down to 0°F (-17°C) outdoor ambient temperature when properly installed.

12. Louver Metal Outdoor Coil Grilles

Available as a field accessory. Provides hail and vandalism protection.

13. Manual Outdoor Air Damper:

Package shall consist of damper, birdscreen, and rainhood which can be preset to admit outdoor air for year-round ventilation.

14. Natural-to-Propane Conversion Kit:

Shall be complete with all required hardware to convert to propane gas operation at 10.0 IN. W.C. manifold pressure.

15. Propane-to-Natural Conversion Kit

Shall be complete with all hardware to convert to natural gas at standard altitude (0 to 2000 ft [0 to 610 m] above sea level).

16. Square-To-Round Duct Transitions (24-48 size):

Shall have the ability to convert the supply and return openings from rectangular to round.

17. Time Guard II

Automatically prevents the compressor from restarting for at least 4 minutes and 45 seconds after shutdown of the compressor. Not required when a corporate programmable thermostat is applied or with a RTU-MP control.

