

48HC
High-Efficiency
Single Package Rooftop
Gas Heat/Electric Cooling
with Puron® (R-410A) Refrigerant
15, 17.5, 20, 25 Tons – (Sizes 17, 20, 24, 28)



Product Data



WeatherMaster®



C10997

(Unit shown with economizer and power exhaust.)



TABLE OF CONTENTS

	PAGE		PAGE
FEATURES AND BENEFITS	3	APPLICATION/SELECTION DATA	31
MODEL NUMBER NOMENCLATURE	4	COOLING CAPACITIES	33
FACTORY OPTIONS AND/OR ACCESSORIES	6	STATIC PRESSURE ADDERS	41
AHRI COOLING RATING TABLES	10	DAMPER, BARO RELIEF & PE PERFORMANCE ...	42
HEATING RATING TABLE	10	FAN PERFORMANCE	44
SOUND PERFORMANCE TABLE	11	ELECTRICAL INFORMATION	49
PHYSICAL DATA	12	TYPICAL WIRING DIAGRAMS	60
DIMENSIONS	15	SEQUENCE OF OPERATION	64
OPTIONS & ACCESSORIES WEIGHT ADDERS ...	30	GUIDE SPECIFICATIONS	67



The 15 to 25 Ton WeatherMaster[®] Carrier rooftop unit (RTU) was designed by customers for customers. With a newly designed cabinet that integrates “no-strip” screw collars, handled access panels, and more we’ve made your unit easy to install, easy to maintain, easy to use and reliable.

Easy to install:

These WeatherMaster units are designed for dedicated factory-supplied vertical or horizontal air flow duct configurations. No special field kits are required. Designed to fit on pre-installed curbs by another manufacturer, these units also fit on past designed Carrier installed curbs with a new certified and authorized adapter curb. This cabinet design also integrates a large control box that gives you room to work and room to mount Carrier accessory controls.

Easy to maintain:

Easy access handles by Carrier provide quick and easy access to all normally serviced components. Our “no-strip” screw system has superior holding power and guides screws into position while preventing the screw from stripping the unit’s metal. Take accurate pressure readings by reading system pressures with panels in place as compressors are strategically located to eliminate any air bypass.

Easy to use:

The newly designed, central terminal board by Carrier puts all your connections and troubleshooting points in one convenient place, standard. Most low voltage connections are made to the same board and make it easy to find what you’re looking for and easy to access it.

Reliable:

Each unit comes with precision sized and tested scroll compressor that is internally protected from over temperature and pressures. In addition, each refrigerant circuit is further protected with a high-pressure and low-pressure switch as well as containing a liquid line filter drier. Each unit is factory tested prior to shipment to help ensure unit operation once properly installed.

FEATURES AND BENEFITS

- Two stage cooling capability with independent circuits and control.
- High performance copper tube / aluminum plate (RTPF) fin condenser and evaporator coils with optional coating.
- EER's up to 12.0
- IEER's up to 13.2 with single speed indoor fan motor and 13.8 with SAV™ (Staged Air Volume) 2-speed/VFD indoor fan motor.
- Gas heating efficiencies up to 81% thermal efficiency.
- Dedicated vertical and horizontal air flow duct configuration models. No field kits required.
- Utility connections through the side or bottom. Bottom connections are also in an enclosed environment to help prevent water entry. Field supplied couplings are required.
- Standardized components and layout. Standardized components and controls make service and stocking parts easier.
- Scroll compressors on all units. This makes service, stocking parts, replacement, and trouble-shooting easier.
- Precision sized TXV metering device on each refrigerant circuit.
- Easy-adjust, belt-drive motor available. Motor assembly also contains a fan belt break protection system on all models and reliable pillow block bearing system that allows lubrication thru front of the unit.
- Single-point gas / electrical connection.
- Sloped, composite drain pan sheds water; and won't rust.
- Standardized controls and control box layout. Standardized components and controls make stocking parts and service easier.
- Clean, large, easy to use control box.
- Color-coded wiring.
- Large, laminated wiring and power wiring drawings which are affixed to unit make troubleshooting easy.
- Single, central terminal board for test and wiring connections.
- Fast-access, handled, panels for easy access on normally accessed service panels.
- "No-strip" screw system guides screws into the panel and captures them tightly without stripping the screw, the panel, or the unit.
- Mechanical cooling (125°F to 35°F / 52°C to -2°C) standard on all models. Low ambient controller allows operation down to -20°F / -29°C
- Redundant gas valve for 2-stage gas heating capacity control with induced-draft flue exhaust design to help ensure no flue gas can escape into the indoor air stream.
- Exclusive IGC solid state gas controller for on board diagnostics with LED error code designation, burner control logic and energy saving indoor fan motor delay.
- 2-in (51 mm) disposable filters on all units, with 4-in (102 mm) filter track field-installed.
- Refrigerant filter-drier on each circuit.
- High and low pressure switches. Added reliability with high-pressure switch and low-pressure switch.
- Many factory-installed options ranging from air management economizers, 2 position dampers, manual outdoor air dampers, plus convenience outlets, disconnect switch and smoke detectors.
- Factory-installed Humidi-MiZer® adaptive dehumidification system.
- Standard Parts Warranty: 10 year aluminized heat exchanger, 5 year compressor, 1 year others.
- Optional Staged Air Volume (SAV) system utilizes a Variable Frequency Drive (VFD) to automatically adjust the indoor fan motor speed between cooling stages. Available on 2-stage cooling models 17-28 with electro-mechanical controls or RTU Open.

MODEL NUMBER NOMENCLATURE

Position:	1	2	3	4	5	6	7	8	9	10	11	12	13	14	15	16	17	18
Example:	4	8	H	C	D	D	2	4	A	3	A	5	-	0	A	0	A	0

Unit Heat Type

48 - Gas Heat Packaged Rooftop

Model Series - WeatherMaster®

HC - High Efficiency

Heat Options

D = Low Gas Heat
 E = Medium Gas Heat
 F = High Gas Heat
 S = Low Heat w/ Stainless Steel Exchanger
 R = Medium Heat w/ Stainless Steel Exchanger
 T = High Heat w/ Stainless Steel Exchanger

Refrig. Systems Options

D = Two stage cooling model
 E = Two stage cooling models with Humidi-MiZer® System
 G = Two stage cooling models with Motormaster® Low Ambient controller

Cooling Tons

17 = 15 tons
 20 = 17.5 tons
 24 = 20 tons
 28 = 25 tons

Sensor Options

A = None
 B = RA Smoke Detector
 C = SA Smoke Detector
 D = RA + SA Smoke Detector
 E = CO₂
 F = RA Smoke Detector and CO₂
 G = SA Smoke Detector and CO₂
 H = RA + SA Smoke Detector and CO₂
 J = Condensate Overflow Switch
 K = Condensate Overflow Switch and RA Smoke Detectors
 L = Condensate Overflow Switch and RA and SA Smoke Detectors

Indoor Fan Options & Air Flow Configuration

1 = Standard Static/Vertical Supply, Return Air Flow
 2 = Medium Static/Vertical Supply, Return Air Flow
 3 = High Static/Vertical Supply, Return Air Flow
 B = Medium Static, High Efficiency Motor/Vertical Supply, Return Air Flow
 C = High Static, High Efficiency Motor/Vertical Supply, Return Air Flow
 5 = Standard Static/Horizontal Supply, Return Air Flow
 6 = Medium Static/Horizontal Supply, Return Air Flow
 7 = High Static/Horizontal Supply, Return Air Flow
 F = Medium Static, High Efficiency Motor/Horizontal Supply, Return Air Flow
 G = High Static, High Efficiency Motor/Horizontal Supply, Return Air Flow

NOTE:

Not all possible options are displayed. See the current 48HC 15 to 25 Ton Price Pages for more details.

Packaging

0 = Standard

Electrical Options

A = None
 B = HACR Breaker
 C = Non-Fused Disconnect
 G = 2-Speed Indoor Fan (VFD) Controller
 J = 2 Speed Fan Controller (VFD) & Non-Fused Disconnect

Service Options

0 = None
 1 = Unpowered Convenience Outlet
 2 = Powered Convenience Outlet
 3 = Hinged Panels
 4 = Hinged Panels & Unpowered Convenience Outlet
 5 = Hinged Panels & Powered Convenience Outlet
 C = Foil Faced Insulation

Intake / Exhaust Options

A = None
 B = Temperature Economizer w/ Barometric Relief
 F = Enthalpy Economizer w/ Barometric Relief
 K = 2-Position Damper
 P = Manual Outdoor Air Damper
 U = Temp Ultra Low Leak Economizer w/ Barometric Relief
 V = Temp Ultra Low Leak Economizer w/ Power Exhaust - Vertical Air Only
 W = Enthalpy Ultra Low Leak Economizer w/ Barometric Relief
 X = Enthalpy Ultra Low Leak Economizer w/ Power Exhaust - Vertical Air Only

Base Unit Controls

0 = Electro-mechanical Controls. Can be used with W7212 EconoMi\$er IV (Non-Fault Detection and Diagnostic)
 1 = PremierLink™ Controller
 2 = RTU Open Multi-Protocol Controller
 6 = Electro-mechanical w/ 2-Speed Fan and W7220 Economizer Controller. Can be used with W7220 EconoMi\$er X (with Fault Detection and Diagnostic)
 D = ComfortLink Controls

Design Revision

- = Factory Design Revision

Voltage

1 = 575/3/60
 5 = 208-230/3/60
 6 = 460/3/60

Coil Options – RTPF (Outdoor - Indoor - Hail Guard)

A = Al/Cu - Al/Cu
 B = Precoat Al/Cu - Al/Cu
 C = E-coat Al/Cu - Al/Cu
 D = E-coat Al/Cu - E-coat Al/Cu
 E = Cu/Cu - Al/Cu
 F = Cu/Cu - Cu/Cu
 M = Al/Cu -Al/Cu — Louvered Hail Guard
 N = Precoat Al/Cu - Al/Cu — Louvered Hail Guard
 P = E-coat Al/Cu - Al/Cu — Louvered Hail Guard
 Q = E-coat Al/Cu - E-coat Al/Cu — Louvered Hail Guard
 R = Cu/Cu - Al/Cu — Louvered Hail Guard
 S = Cu/Cu - Cu/Cu — Louvered Hail Guard

C160095

Table 1 – FACTORY-INSTALLED OPTIONS AND FIELD-INSTALLED ACCESSORIES

CATEGORY	ITEM	FACTORY-INSTALLED OPTION	FIELD-INSTALLED ACCESSORY
Cabinet	Dedicated Vertical Air Flow Duct Configuration	X	
	Dedicated Horizontal Air Flow Duct Configuration	X	
	Hinged Access Panels	X	
	Foil faced insulation throughout entire cabinet	X	
Coil Options	Cu/Cu (indoor) coils	X	
	E-coated (outdoor & indoor) coils	X	
	Pre-coated outdoor coils	X	
Humidity Control	Humidi-MiZer® Adaptive Dehumidification System	X	
Condenser Protection	Condenser coil hail guard (louvered design)	X	X
Controls	Thermostats, temperature sensors, and subbases		X
	PremierLink™ DDC communicating controller	X	X
	ComfortLink Controls	X	X
	RTU Open protocol controller	X	
	Smoke detector (supply and/or return air)	X	X
	Horn/Strobe Annunciator ⁹		X
	Time Guard II compressor delay control circuit		X
	Phase Monitor		X
	Condensate Overflow switch – for electro-mechanical controls only		X
	Carrier Energy Demand System (EDS)		X
Economizers & Outdoor Air Dampers	EconoMi\$er IV for electro-mechanical controls – Non FDD (Standard air leak damper models) ⁷	X	X
	EconoMi\$er 2 for DDC controls, complies with FDD (Standard and Ultra Low Leak air damper models) ^{7, 8}	X	X
	Motorized 2 position outdoor-air damper	X	X
	Manual outdoor-air damper (25%)	X	X
	Barometric relief ¹	X	X
	Barometric hood (Horizontal economizer)		X
	Power exhaust-centrifugal blower	X	X
EconoMi\$er X for electro-mechanical controls, complies with FDD. (Standard and Ultra Low Leak air damper models.) ⁷	X	X	
Economizer Sensors & IAQ Devices	Single dry bulb temperature sensors ²	X	X
	Differential dry bulb temperature sensors ²		X
	Single enthalpy sensors ²	X	X
	Differential enthalpy sensors ²		X
	Wall or duct mounted CO ₂ sensor ²		X
	Unit mounted CO ₂ sensor ²	X	
Gas Heat	4-in Filter Track Assembly		X
	Propane conversion kit		X
	Stainless steel heat exchanger	X	
	High altitude conversion kit		X
Indoor Motor & Drive	Flue Discharge Deflector		X
	Multiple motor and drive packages	X	
	Staged Air Volume (SAV™) system w/VFD controller (2-stage cool only with electro-mechanical and RTU Open controls)	X	
Low Ambient Control	Display Kit for SAV system with VFD		X
	Winter start kit ³		X
Power Options	Motormaster® head pressure controller to -20°F (-29°C) ³		X
	Convenience outlet (powered)	X	
	Convenience outlet (unpowered)	X	
	HACR circuit breaker ⁵	X	
Roof Curbs	Non-fused disconnect ⁴	X	
	Roof curb 14-in (356 mm)		X
	Roof curb 24-in (610 mm)		X
	Adapter Curb (Adapts to Models – DP/DR/HJ/TM/TJ) ⁵		X

NOTES:

- Included with economizer.
- Sensors used to optimize economizer performance.
- See application data for assistance.
- Non-fused disconnect switch cannot be used when MOCP electrical rating exceeds 70 amps at 460/575 volt and 150 amps at 208/230 volt. Carrier Packaged RTUBuilder selects this automatically.
- HACR circuit breaker cannot be used when rooftop MOCP electrical rating exceeds 200 amps at 208/230 volt, 90 amps at 460 volt and 90 amps at 575 volt. 575 volt can only be used on Wye power supply. Delta power supply is prohibited. Carrier RTUBuilder selects this automatically.
- Not for 48TJE024-028 models using 48DP900041, 48DP900051 or 48DP900061 roof curbs.
- FDD (Fault Detection and Diagnostic) capability per California Title 24 section 120.2.
- Models with RTU Open and ComfortLink DDC controls comply with California Title 24 Fault Detection and Diagnostic (FDD). PremierLink Controller is non FDD.
- Requires a field-supplied 24V transformer for each application. See price pages for details.

FACTORY OPTIONS AND/OR ACCESSORIES

Economizer (dry-bulb or enthalpy)

Economizers can reduce operating costs. They bring in fresh, outside air for ventilation; and provide cool outside air to cool your building. This also is the preferred method of low ambient cooling. When coupled to CO₂ sensors, economizers can limit the ventilation air to only that amount required.

Economizers are available, installed and tested by the factory, with either enthalpy or temperature dry-bulb inputs. There are also models for electro-mechanical, direct digital controllers and single speed fan or 2-speed indoor fan motors. Additional sensors are available as accessories to optimize the economizer.

Economizers include gravity controlled barometric relief that helps equalize building pressure and ambient air pressures. This can be a cost effective solution to prevent building pressurization. Economizers are available in Ultra Low Leak and standard low leak versions.

CO₂ Sensor

The CO₂ sensor works with the economizer to intake only the correct amount of outside air for ventilation. As occupants fill your building, the CO₂ sensor detects their presence through increasing CO₂ levels, and opens the economizer appropriately.

When the occupants leave, the CO₂ levels decrease, and the sensor appropriately closes the economizer. This intelligent control of the ventilation air, called Demand Controlled Ventilation (DCV) reduces the overall load on the rooftop, saving money.

Smoke Detectors

Trust the experts. Smoke detectors make your application safer and your job easier. Carrier smoke detectors immediately shut down the rooftop unit when smoke is detected. They are available, installed by the factory, for supply air, return air, or both.

Louvered Hail Guards

Sleek, louvered panels protect the condenser coil from hail damage, foreign objects, and incidental contact.

Convenience Outlet (powered or un-powered)

Reduce service and/or installation costs by including a convenience outlet in your specification. Carrier will install this service feature at our factory. Provides a convenient, 15 amp, 115v GFCI receptacle with “Wet in Use” cover. The “powered” option allows the installer to power the outlet from the line side of the disconnect side as required by code. The “unpowered” option is to be powered from a separate 115/120v power source.

Non-Fused Disconnect

This OSHA-compliant, factory-installed, safety switch allows a service technician to locally secure power to the rooftop.

When selecting a factory-installed non-fused disconnect, note they are sized for unit as ordered from the factory. The sizing of these does not accommodate any power exhaust devices, etc.

Power Exhaust with Barometric Relief

Superior internal building pressure control. This field-installed accessory or factory-installed option may eliminate the need for costly, external pressure control fans.

PremierLink™ DDC Controller

This CCN controller regulates your rooftop’s performance to tighter tolerances and expanded limits, as well as facilitates zoning systems and digital accessories. It also unites your Carrier HVAC equipment together on one, coherent CCN network. The PremierLink Controller can be factory-installed, or easily field-installed.

RTU Open Protocol Controller

Connect the rooftop to an existing BAS without needing complicated translators or adapter modules using the RTU Open controller. This new controller speaks the 4 most common building automation system languages (BACnet*, Modbus†, N2, and LonWorks**). Use this controller when you have an existing BAS.

Time Guard II Control Circuit

This accessory protects your compressor by preventing short-cycling in the event of some other failure, prevents the compressor from restarting for 30 seconds after stopping. Not required with PremierLink, RTU Open, or authorized commercial thermostats.

Motorized 2-Position Damper

The new Carrier 2-position, motorized outdoor air damper admits up to 100% outside air. Using reliable, gear-driven technology, the 2-position damper opens to allow ventilation air and closes when the rooftop stops, stopping unwanted infiltration.

Manual OA Damper

Manual outdoor air dampers are an economical way to bring in ventilation air. The dampers are available in 25% versions.

Optional Humidi-MiZer® Adaptive Dehumidification System

Carrier’s Humidi-MiZer adaptive dehumidification system is an all-inclusive factory-installed option that can be ordered with any WeatherMaster® 48HC17-28 rooftop unit.

This system expands the envelope of operation of Carrier’s WeatherMaster rooftop products to provide unprecedented flexibility to meet year round comfort conditions.

The Humidi-MiZer adaptive dehumidification system has a unique dual operational mode setting. The Humidi-MiZer system includes two new modes of operation.

* BACnet is a registered trademark of ASHRAE (American Society of Heating, Refrigerating and Air-Conditioning Engineers).

† Modbus is a registered trademark of Schneider Electric.

** LonWorks is a registered trademark of Echelon Corporation.

FACTORY OPTIONS AND/OR ACCESSORIES (cont.)

Opt. Humidi-MiZer[®] Adaptive Dehumidification System (cont.)

The WeatherMaster[®] 48HC17-28 rooftop coupled with the Humidi-MiZer system is capable of operating in normal design cooling mode, subcooling mode, and hot gas reheat mode. Normal design cooling mode is when the unit will operate under its normal sequence of operation by cycling compressors to maintain comfort conditions.

Subcooling mode will operate to satisfy part load type conditions when the space requires combined sensible and a higher proportion of latent load control. Hot Gas Reheat mode will operate when outdoor temperatures diminish and the need for latent capacity is required for sole humidity control. Hot Gas Reheat mode will provide neutral air for maximum dehumidification operation.

Staged Air Volume (SAV[™]) Indoor Fan Speed System

Carrier's Staged Air Volume (SAV) system saves energy and installation time by utilizing a Variable Frequency Drive (VFD) to automatically adjust the indoor fan motor speed in sequence with the units cooling operation. Per ASHRAE 90.1 standard, during the first stage of cooling operation the VFD will adjust the fan motor to provide 66% of the total cfm established for the unit. When a call for the second stage of cooling is required, the VFD will allow the total cfm for the unit established (100%). During the heating mode the VFD will allow total design cfm (100%) operation and during the ventilation mode the VFD will allow operation to 66% of total cfm.

Compared to single speed indoor fan motor systems, Carrier's SAV system can save substantial energy, 25%+, versus single speed indoor fan motor systems.

IMPORTANT: Data based on .10 (\$/kWh) in an office application utilizing Carrier's HAP 4.6 simulation software program.

The VFD used in Carrier's SAV system has soft start capabilities to slowly ramp up the speeds, thus eliminating any high inrush air volume during initial start-up. It also has internal over current protection for the fan motor and a field-installed display kit that allows adjustment and in depth diagnostics of the VFD.

This SAV system is available on models with 2-stage cooling operation with electrical mechanical or RTU Open, Multi Protocol controls. Both space sensor and conventional thermostats controls can be used to provide accurate control in any application.

The SAV system is very flexible for initial fan performance set up and adjustment. The standard factory shipped VFD is pre-programmed to automatically stage the fan speed between the first and second stage of cooling. The unit fan performance static pressure and cfm can be easily adjusted using the traditional means of pulley adjustments. The other means to adjust the unit static and cfm performance is to utilize the field-installed

Display Kit and adjust the frequency and voltage in the VFD to required performance requirements. In either case, once set up, the VFD will automatically adjust the speed between the cooling stage operations.

Motormaster[®] Head Pressure Controller

The Motormaster motor controller is a low ambient, head pressure controller kit that is designed to maintain the unit's condenser head pressure during periods of low ambient cooling operation. This device should be used as an alternative to economizer free cooling when economizer usage is either not appropriate or desired. The Motormaster will either cycle the outdoor-fan motors or operate them at reduced speed to maintain the unit operation, depending on the model.

Motormaster allows cooling operation down to -20°F (-29°C) ambient conditions.

Winter Start Kit

The winter start kit by Carrier extends the low ambient limit of your rooftop to 25°F (-4°C). The kit bypasses the low pressure switch, preventing nuisance tripping of the low pressure switch. Other low ambient precautions may still be prudent.

Propane Heating

Convert your gas heat rooftop from standard natural gas operation to Propane using this field-installed kit.

High Altitude Heating

High altitudes have less oxygen, which means heat exchangers need less fuel. The new gas orifices in this field-installed kit make the necessary adjustment for high altitude applications. They restore the optimal fuel to air mixture and maintain healthy combustion at altitudes above 2000 ft (610 m). Kits may not be required in all areas.

Optional Stainless Steel Heat Exchanger

The stainless steel heat exchanger option provides the tubular heat exchanger be made out of a minimum 20 gauge type 409 stainless steel for applications where the mixed air to the heat exchanger is expected to drop below 45°F (7°C). Stainless steel may be specified on applications where the presence of airborne contaminants require its use (applications such as paper mills) or in area with very high outdoor humidity that may result in severe condensation in the heat exchanger during cooling operation.

Flue Discharge Deflector

The flue discharge deflector is a useful accessory when flue gas recirculation is a concern. By venting the flue discharge upwards, the deflector minimizes the chance for a neighboring unit to intake the flue exhaust.

FACTORY OPTIONS AND/OR ACCESSORIES (cont.)

Hinged Access Panels

Allows access to unit's major components with specifically designed hinged access panels. Panels are filter, control box, indoor fan motor.

Alternate Motors and Drives

Some applications need larger horsepower motors, some need more airflow, and some need both. Regardless of the case, your Carrier expert has a factory-installed combination to meet your application. A wide selection of motors and pulleys (drives) are available, factory-installed, to handle nearly any application.

Thru-the-Base Connections

Thru-the-base provisions/connection points are available as standard with every unit. When bottom connections are required, field furnished couplings are required.

Barometric Hood

For Horizontal Economizer applications where relief damper is installed in duct work. This kit provides the needed protection.

ComfortLink Controls

Models with the optional Carrier ComfortLink Controls allow added unit diagnostics and operation setup capabilities, as well as controlling logic for single zone Variable Air Volume (VAV) applications.

The ComfortLink control is your link to a world of simple and easy to use rooftop units that offer outstanding performance and value. It optimizes the performance of the refrigeration circuits as conditions change, resulting in the following features:

- Better control of temperature and humidity
- Superior reliability
- Automatic redundancy
- Low ambient cooling operation to 0°F (-18°C)
- More accurate diagnostics, at unit or remote

The ComfortLink Scrolling Marquee is very easy to use. The messages are displayed in easy to understand English, no decoding is required. A scrolling readout provides detailed explanations of control information. Only four, large, easy-to-use buttons are required to maneuver through the entire menu. The readout is designed to be visible even in the brightest sunlight. A handheld Navigator accessory or wall-mounted System Pilot™ accessory can be used for added service flexibility.

The ComfortLink control provides service diagnostic information. Temperature and pressure can be read directly from the display with no need for separate gauges. Other data, such as compressor cycles, unit run time hours, current alarms, can also be accessed. A history of alarms is also available for viewing.

The service run test can be very helpful when troubleshooting. The user can run test major components to determine the root cause of a problem. The unit can be run-tested before an installation is complete to ensure satisfactory start-up. To ensure reliability, the ComfortLink control prevents reverse compressor rotation. No laptop computers are required for start-up.

Time schedules are built in and the Scrolling Marquee display provides easy access to setpoints. The ComfortLink control accepts input from a CO₂ sensor and a smoke detector. Both are available as factory-installed options or as field-installed accessories.

HACR Breaker

These manual reset devices provide overload and short circuit protection for the unit. Factory wired and mounted with the units with access cover to help provide environment protection.

On 575V applications, HACR breaker can only be used with WYE power distribution systems. Use on Delta power distribution systems is prohibited.

Foil Faced Insulated Cabinet

Cabinet is fully insulated with non-fibrous, foil faced cleanable insulation that is secured and encapsulated in unit design.

Low Ambient Controller

The low ambient controller is a head pressure controller kit that is designed to maintain the unit's condenser head pressure during periods of low ambient cooling operation. This device should be used as an alternative to economizer free cooling not when economizer usage is either not appropriate or desired. The low ambient controller will either cycle the outdoor fan motors or operate them at reduced speed to maintain the unit operation, depending on the model. This controller allows cooling operation down to 0°F (-18°C) ambient conditions.

Condensate Overflow Switch (Factory-Installed Option)

This sensor and related controller monitors the condensate level in the drain pan and shuts down compression operation when overflow conditions occur. It includes:

- Indicator light - solid red (more than 10 seconds on water contact - compressors disabled), blinking red (sensor disconnected)
- 10 second delay to break - eliminates nuisance trips from splashing or waves in pan (sensor needs 10 seconds of constant water contact before tripping)
- Disables the compressor(s) operation when condensate plug is detected, but still allows fans to run for Economizer.

NOTE: The Condensate Overflow switch FIOP is only available for units with electro-mechanical controls.

FACTORY OPTIONS AND/OR ACCESSORIES (cont.)

Carrier Energy Demand System (EDS)

Carrier's wireless automated demand management and demand response controllers can be easily installed onto any packaged rooftop unit. Once installed, the controllers work together like a swarm of bees, intelligently communicating and managing the duty cycles of the units being controlled.

Utilizing patented intelligence, the controllers dramatically reduce peak electrical demand by up to 30 percent in commercial and light industrial properties and allow for effective scheduling of overnight and weekend loads. This platform can easily be installed when a full building automation system is not required.

The Energy Demand System is as easy to install as thermostats, and requires no special training. Every controller has a built-in self-configuring wireless network. The controllers work together to establish a wireless network, eliminating the need for expensive wiring. The secure web portal allows property managers to easily access multiple sites from any internet connection to monitor building performance and reconfigure controllers for demand response or the scheduling of loads.

- Simple, affordable, wireless electrical demand management
- Automated demand response, including Open ADR
- Energy consumption reduction through efficient schedule-based control
- Intelligent, adaptive energy management
- Web-based interface
- Electrical demand reductions
- Helps reduce energy costs, not comfort

Table 2 – AHRI COOLING RATING TABLE 2-STAGE COOLING

48HC MODEL SIZE	COOLING STAGES	NOM. CAPACITY (TONS)	NET COOLING CAPACITY (MBH)	CONFIGURATION	TOTAL POWER (kW)	EER	IEER WITH SINGLE SPEED INDOOR FAN	IEER WITH 2-SPEED INDOOR FAN
17	2	15	174.0	Vertical	14.5	12.0	13.0	13.5
17	2	15	174.0	Horizontal	15.1	11.5	12.0	13.0
20	2	17.5	202.0	Vertical	16.8	12.0	13.0	13.6
20	2	17.5	202.0	Horizontal	17.9	11.3	11.5	13.2
24	2	20	232.0	Vertical	19.3	12.0	13.2	13.8
24	2	20	232.0	Horizontal	20.4	11.4	12.0	13.0
28	2	25	282.0	Vertical	25.2	11.2	12.0	12.5
28	2	25	282.0	Horizontal	26.9	10.5	N/A	11.9

LEGEND

- AHRI – Air-Conditioning, Heating and Refrigeration Institute Test Standard
- ASHRAE – American Society of Heating, Refrigerating and Air-Conditioning Engineers
- EER – Energy Efficiency Ratio
- IEER – Integrated Energy Efficiency Ratio

NOTES:

1. Rated and certified under AHRI Standard 340/360, as appropriate.
2. Ratings are based on:
Cooling Standard: 80°F (27°C) db, 67°F (19°C) wb indoor air temp and 95°F (35°C) db outdoor air temp.
IEER Standard: A measure that expresses cooling part-load EER efficiency for commercial unitary air conditioning and heat pump equipment on the basis of weighted operation at various load capacities.
3. All 48HC units comply with ASHRAE 90.1 and Energy Star Energy Standard for minimum EER and IEER requirements.
4. 48HC units comply with US Energy Policy Act (2005). To evaluate code compliance requirements, refer to state and local codes or visit the following website: <http://bcap-energy.org> to determine if compliance with this standard pertains to your state, territory, or municipality.



Use of the AHRI Certified TM Mark indicates a manufacturer's participation in the program. For verification of certification for individual products, go to www.ahridirectory.org.

Table 3 – HEATING RATING TABLE - NATURAL GAS & PROPANE

48HC MODEL SIZE	HEAT SIZE	AL/SS HEAT EXCHANGER		TEMP RISE (DEG F)	THERMAL EFFICIENCY (%)
		INPUT / OUTPUT STAGE 1 (MBH)	INPUT / OUTPUT STAGE 2 (MBH)		
17	LOW	176 / 142	220 / 178	20 – 55	81%
	MED	248 / 200	310 / 251	30 – 60	81%
	HIGH	320 / 260	400 / 324	35 – 65	81%
20	LOW	176 / 142	220 / 178	15 – 55	81%
	MED	248 / 200	310 / 251	25 – 60	81%
	HIGH	320 / 260	400 / 324	30 – 65	81%
24	LOW	176 / 142	220 / 178	15 – 55	81%
	MED	248 / 200	310 / 251	20 – 60	81%
	HIGH	320 / 260	400 / 324	30 – 65	81%
28	LOW	176 / 142	220 / 178	10 – 55	81%
	MED	248 / 200	310 / 251	15 – 60	81%
	HIGH	320 / 260	400 / 324	20 – 65	81%

NOTES:

1. Heat ratings are for natural gas heat exchangers operated at or below 2000 ft (610 m). For information on Propane or altitudes above 2000 ft (610 m), see the Application Data section of this book. Accessory Propane/High Altitude kits are also available.
2. In the USA the input rating for altitudes above 2000 ft (610 m) must be derated by 4% for each 1000 ft (305 m) above sea level.

Table 4 – SOUND PERFORMANCE TABLE

48HC Model Size	Cooling Stages	A-Weighted	AHRI 370 Rating	OUTDOOR SOUND (dB) AT 60 Hz							
				63	125	250	500	1000	2000	4000	8000
17	2	84.1	84	92.2	83.9	80.4	81.8	78.7	76.5	72.2	65.4
20	2	84.1	84	92.2	83.9	80.4	81.8	78.7	76.5	72.2	65.4
24	2	86.5	87	95.6	87.5	84.2	84.2	81.7	77.9	73.2	66.3
28	2	85.9	86	97.1	88.3	84.4	83.3	80.7	77.4	73.4	67.3

LEGEND

dB – Decibel

NOTES:

1. Outdoor sound data is measured in accordance with AHRI standard 370.
2. Measurements are expressed in terms of sound power. Do not compare these values to sound pressure values because sound pressure depends on specific environmental factors which normally do not match individual applications. Sound power values are independent of the environment and therefore more accurate.
3. A-weighted sound ratings filter out very high and very low frequencies, to better approximate the response of "average" human ear. A-weighted measurements for Carrier units are taken in accordance with AHRI standard 370.

Table 5 – MINIMUM - MAXIMUM AIRFLOW RATINGS (CFM) - NATURAL GAS & PROPANE

48HC MODEL SIZE	HEAT SIZE	COOLING				AL HEAT EXCHANGER HEATING		SS HEAT EXCHANGER HEATING	
		Minimum Single Speed Fan Motor	Minimum 2-speed Fan Motor (at high speed)	Minimum 2-speed Fan Motor (at low speed)	Maximum	Minimum	Maximum	Minimum	Maximum
17	LOW	4500	5070	3380	7500	3000	8250	3000	8250
	MED					3880	7750	3880	7750
	HIGH					4620	8570	4620	8570
20	LOW	5250	5915	3943	9000	3000	11000	3000	11000
	MED					3880	9300	3880	9300
	HIGH					4620	10000	4620	10000
24	LOW	6000	7500	5000	10000	3000	11000	3000	11000
	MED					3880	11630	3880	11630
	HIGH					4620	10000	4620	10000
28	LOW	7500	8450	5633	12500	3000	16500	3000	16500
	MED					3880	15500	3880	15500
	HIGH					4620	15000	4620	15000

AL = Aluminum Gas Heat Exchanger

SS = Stainless Steel Gas Heat Exchanger

Table 6 – PHYSICAL DATA

(COOLING)

15 - 25 TONS

	48HC**17	48HC**20	48HC**24	48HC**28	
Refrigeration System					
# Circuits / # Comp. / Type	2 / 2 / Scroll	2 / 2 / Scroll	2 / 2 / Scroll	2 / 2 / Scroll	
R-410A charge A/B (lbs)	17/16.4	17.5/16.8	23.8/23.1	24.9/27.7	
w/ Humidi-MiZer® R-410A charge A/B (lbs)	24.5/25.7	25.5/25.5	30.0/30.7	35.1/35.4	
Metering device	TXV	TXV	TXV	TXV	
High-press. Trip / Reset (psig)	630 / 505	630 / 505	630 / 505	630 / 505	
Low-press. Trip / Reset (psig)	54 / 117	54 / 117	54 / 117	54 / 117	
w/ Humidi-MiZer, Low-press. Trip / Reset (psig)	27 / 44	27 / 44	27 / 44	27 / 44	
Evap. Coil					
Material	Cu / Al	Cu / Al	Cu / Al	Cu / Al	
Tube Diameter	3/8-in RTPF	3/8-in RTPF	3/8-in RTPF	3/8-in RTPF	
Rows / FPI	4 / 15	4 / 15	4 / 15	4 / 15	
Total face area (ft ²)	22	22	26	26	
Condensate drain conn. size	3/4-in	3/4-in	3/4-in	3/4-in	
Humidi-MiZer Coil					
Material	Cu / Al	Cu / Al	Cu / Al	Cu / Al	
Tube Diameter	3/8-in RTPF	3/8-in RTPF	3/8-in RTPF	3/8-in RTPF	
Rows / FPI	1 / 17	1 / 17	1 / 17	1 / 17	
Total face area (ft ²)	22	22	26	26	
Evap. fan and motor					
VERTICAL					
Standard Static	Motor Qty / Belt Qty / Drive type	1 / 1 / Belt	1 / 1 / Belt	n/a	1 / 1 / Belt
	Max BHP	2.9	3.7	n/a	4.9
	RPM range	514-680	622-822	n/a	717-911
	Motor frame size	56	56	n/a	56
	Fan Qty / Type	2 / Centrifugal	2 / Centrifugal	n/a	2 / Centrifugal
	Fan Diameter (in)	15 x 15	15 x 15	n/a	15 x 15
Medium Static	Motor Qty / Belt Qty / Drive type	1 / 1 / Belt	1 / 1 / Belt	n/a	n/a
	Max BHP	3.7	4.9	n/a	n/a
	RPM range	679-863	713-879	n/a	n/a
	Motor frame size	56	56	n/a	n/a
	Fan Qty / Type	2 / Centrifugal	2 / Centrifugal	n/a	n/a
	Fan Diameter (in)	15 x 15	15 x 15	n/a	n/a
High Static	Motor Qty / Belt Qty / Drive type	1 / 1 / Belt	n/a	n/a	n/a
	Max BHP	4.9	n/a	n/a	n/a
	RPM range	826-1009	n/a	n/a	n/a
	Motor frame size	56	n/a	n/a	n/a
	Fan Qty / Type	2 / Centrifugal	n/a	n/a	n/a
	Fan Diameter (in)	15 x 15	n/a	n/a	n/a
Standard Static High Efficiency	Motor Qty / Belt Qty / Drive type	n/a	n/a	1 / 1 / Belt	n/a
	Max BHP (208/230/460/575v)	n/a	n/a	6.5/6.9/7.0/8.3	n/a
	RPM range	n/a	n/a	690-863	n/a
	Motor frame size	n/a	n/a	184T	n/a
	Fan Qty / Type	n/a	n/a	2 / Centrifugal	n/a
	Fan Diameter (in)	n/a	n/a	15 x 15	n/a
Medium Static High Efficiency	Motor Qty / Belt Qty / Drive type	n/a	n/a	1 / 1 / Belt	1 / 1 / Belt
	Max BHP (208/230/460/575v)	n/a	n/a	6.5/6.9/7.0/8.3	6.5/6.9/7.0/8.3
	RPM range	n/a	n/a	835-1021	913-1116
	Motor frame size	n/a	n/a	184T	184T
	Fan Qty / Type	n/a	n/a	2 / Centrifugal	2 / Centrifugal
	Fan Diameter (in)	n/a	n/a	15 x 15	15 x 15
High Static High Efficiency	Motor Qty / Belt Qty / Drive type	n/a	1 / 1 / Belt	1 / 1 / Belt	1 / 1 / Belt
	Max BHP (208/230/460/575v)	n/a	6.5/6.9/7.0/8.3	10.5/11.9/11.9/11	10.5/11.9/11.9/11
	RPM range	n/a	882-1078	941-1176	941-1176
	Motor frame size	n/a	184T	213T	213T
	Fan Qty / Type	n/a	2 / Centrifugal	2 / Centrifugal	2 / Centrifugal
	Fan Diameter (in)	n/a	15 x 15	15 x 15	15 x 15

Table 6 – PHYSICAL DATA (cont.)

(COOLING)

15 - 25 TONS

		48HC**17	48HC**20	48HC**24	48HC**28
HORIZONTAL					
Standard Static	Motor Qty / Belt Qty / Drive type	1 / 1 / Belt	1 / 1 / Belt	n/a	n/a
	Max BHP	2.9	3.7	n/a	n/a
	RPM range	514–680	622–822	n/a	n/a
	Motor frame size	56	56	n/a	n/a
	Fan Qty / Type	2 / Centrifugal	2 / Centrifugal	n/a	n/a
	Fan Diameter (in)	18 x 15/15 X 11	18 x 15/15 X 11	n/a	n/a
Medium Static	Motor Qty / Belt Qty / Drive type	1 / 1 / Belt	1 / 1 / Belt	n/a	n/a
	Max BHP	3.7	4.9	n/a	n/a
	RPM range	614–780	713–879	n/a	n/a
	Motor frame size	56	56	n/a	n/a
	Fan Qty / Type	2 / Centrifugal	2 / Centrifugal	n/a	n/a
	Fan Diameter (in)	18 x 15/15 X 11	18 x 15/15 X 11	n/a	n/a
High Static	Motor Qty / Belt Qty / Drive type	1 / 1 / Belt	n/a	n/a	n/a
	Max BHP	4.9	n/a	n/a	n/a
	RPM range	746–912	n/a	n/a	n/a
	Motor frame size	56	n/a	n/a	n/a
	Fan Qty / Type	2 / Centrifugal	n/a	n/a	n/a
	Fan Diameter (in)	18 x 15/15 X 11	n/a	n/a	n/a
Standard Static High Efficiency	Motor Qty / Belt Qty / Drive type	n/a	n/a	1 / 1 / Belt	n/a
	Max BHP (208/230/460/575v)	n/a	n/a	6.5/6.9/7.0/8.3	n/a
	RPM range	n/a	n/a	690–863	n/a
	Motor frame size	n/a	n/a	184T	n/a
	Fan Qty / Type	n/a	n/a	2 / Centrifugal	n/a
	Fan Diameter (in)	n/a	n/a	18 x 15/15 X 11	n/a
Medium Static High Efficiency	Motor Qty / Belt Qty / Drive type	n/a	n/a	1 / 1 / Belt	1 / 1 / Belt
	Max BHP (208/230/460/575v)	n/a	n/a	6.5/6.9/7.0/8.3	6.5/6.9/7.0/8.3
	RPM range	n/a	n/a	835–1021	755/923
	Motor frame size	n/a	n/a	184T	184T
	Fan Qty / Type	n/a	n/a	2 / Centrifugal	2 / Centrifugal
	Fan Diameter (in)	n/a	n/a	18 x 15/15 X 11	18 x 15/15 X 11
High Static High Efficiency	Motor Qty / Belt Qty / Drive type	n/a	1 / 1 / Belt	1 / 1 / Belt	1 / 1 / Belt
	Max BHP (208/230/460/575v)	n/a	6.5/6.9/7.0/8.3	10.5/11.9/11.9/11	10.5/11.9/11.9/11
	RPM range	n/a	835–1021	941–1100	906–1100
	Motor frame size	n/a	184T	213T	213T
	Fan Qty / Type	n/a	2 / Centrifugal	2 / Centrifugal	2 / Centrifugal
	Fan Diameter (in)	n/a	18 x 15/15 X 11	18 x 15/15 X 11	18 x 15/15 X 11
Cond. Coil (Circuit A)					
	Coil type	RTPF	RTPF	RTPF	RTPF
	Coil Length (in)	70	72	82	95
	Coil Height (in)	44	44	52	52
	Rows / FPI (fins per inch)	2 / 17	2 / 17	2 / 17	2 / 17
	Total face area (ft ²)	21.4	22.0	29.6	34.3
Cond. Coil (Circuit B)					
	Coil type	RTPF	RTPF	RTPF	RTPF
	Coil Length (in)	70	64	80	95
	Coil Height (in)	44	44	52	52
	Rows / FPI (fins per inch)	2 / 17	2 / 17	2 / 17	2 / 17
	Total face area (ft ²)	21.4	19.5	29.6	34.3
Cond. fan / motor					
	Qty / Motor drive type	3 / direct	4 / direct	4/ direct	6 / direct
	Motor HP / RPM	1/4 / 1100	1/4 / 1100	1/4 / 1100	1/4 / 1100
	Fan diameter (in)	22	22	22	22
Filters					
	RA Filter # / size (in)	6 / 20 x 25 x 2	6 / 20 x 25 x 2	9 / 16 x 25 x 2	9 / 16 x 25 x 2
	OA inlet screen # / size (in)	4 / 16 x 25 x 1	4 / 16 x 25 x 1	4 / 16 x 25 x 1	4 / 16 x 25 x 1

Table 7 – PHYSICAL DATA

(HEATING)

15 - 25 TONS

		48HC**17	48HC**20	48HC**24	48HC**28
Gas Connection					
	# of Gas Valves	1	1	1	1
	Nat. gas supply line press (in. w.g.)/(PSIG)	5 – 13 / 0.18–0.47	5 – 13 / 0.18–0.47	5 – 13 / 0.18–0.47	5 – 13 / 0.18–0.47
	Propane supply line press (in. w.g.)/(PSIG)	11– 13 / 0.40–0.47	11– 13 / 0.40–0.47	11– 13 / 0.40–0.47	11– 13 / 0.40–0.47
Heat Anticipator Setting (Amps)					
	1st stage	0.14	0.14	0.14	0.14
	2nd stage	0.14	0.14	0.14	0.14
Natural Gas Heat					
LOW	# of stages / # of burners (total)	2 / 5	2 / 5	2 / 5	2 / 5
	Connection size	3/4–in NPT	3/4–in NPT	3/4–in NPT	3/4–in NPT
	Rollout switch opens / closes (F)	195 / 115	195 / 115	195 / 115	195 / 115
	Temperature rise range (F)	25 – 55	25 – 55	25 – 55	25 – 55
MED	# of stages / # of burners (total)	2 / 7	2 / 7	2 / 7	2 / 7
	Connection size	3/4–in NPT	3/4–in NPT	3/4–in NPT	3/4–in NPT
	Rollout switch opens / closes (F)	195 / 115	195 / 115	195 / 115	195 / 115
	Temperature rise range (F)	30 – 60	30 – 60	30 – 60	30 – 60
HIGH	# of stages / # of burners (total)	2 / 10	2 / 10	2 / 10	2 / 10
	Connection size	3/4–in NPT	3/4–in NPT	3/4–in NPT	3/4–in NPT
	Rollout switch opens / closes (F)	195 / 115	195 / 115	195 / 115	195 / 115
	Temperature rise range (F)	35 – 65	35 – 65	35 – 65	35 – 65
Liquid Propane Heat					
LOW	# of stages / # of burners (total)	2 / 5	2 / 5	2 / 5	2 / 5
	Connection size	3/4–in NPT	3/4–in NPT	3/4–in NPT	3/4–in NPT
	Rollout switch opens / closes (F)	195 / 115	195 / 115	195 / 115	195 / 115
	Temperature rise range (F)	25 – 55	25 – 55	25 – 55	25 – 55
MED	# of stages / # of burners (total)	2 / 7	2 / 7	2 / 7	2 / 7
	Connection size	3/4–in NPT	3/4–in NPT	3/4–in NPT	3/4–in NPT
	Rollout switch opens / closes (F)	195 / 115	196 / 115	197 / 115	198 / 115
	Temperature rise range (F)	30 – 60	30 – 60	30 – 60	30 – 60
HIGH	# of stages / # of burners (total)	2 / 10	2 / 10	2 / 10	2 / 10
	Connection size	3/4–in NPT	3/4–in NPT	3/4–in NPT	3/4–in NPT
	Rollout switch opens / closes (F)	195 / 115	195 / 115	195 / 115	195 / 115
	Temperature rise range (F)	35 – 65	35 – 65	35 – 65	35 – 65

DIMENSIONS

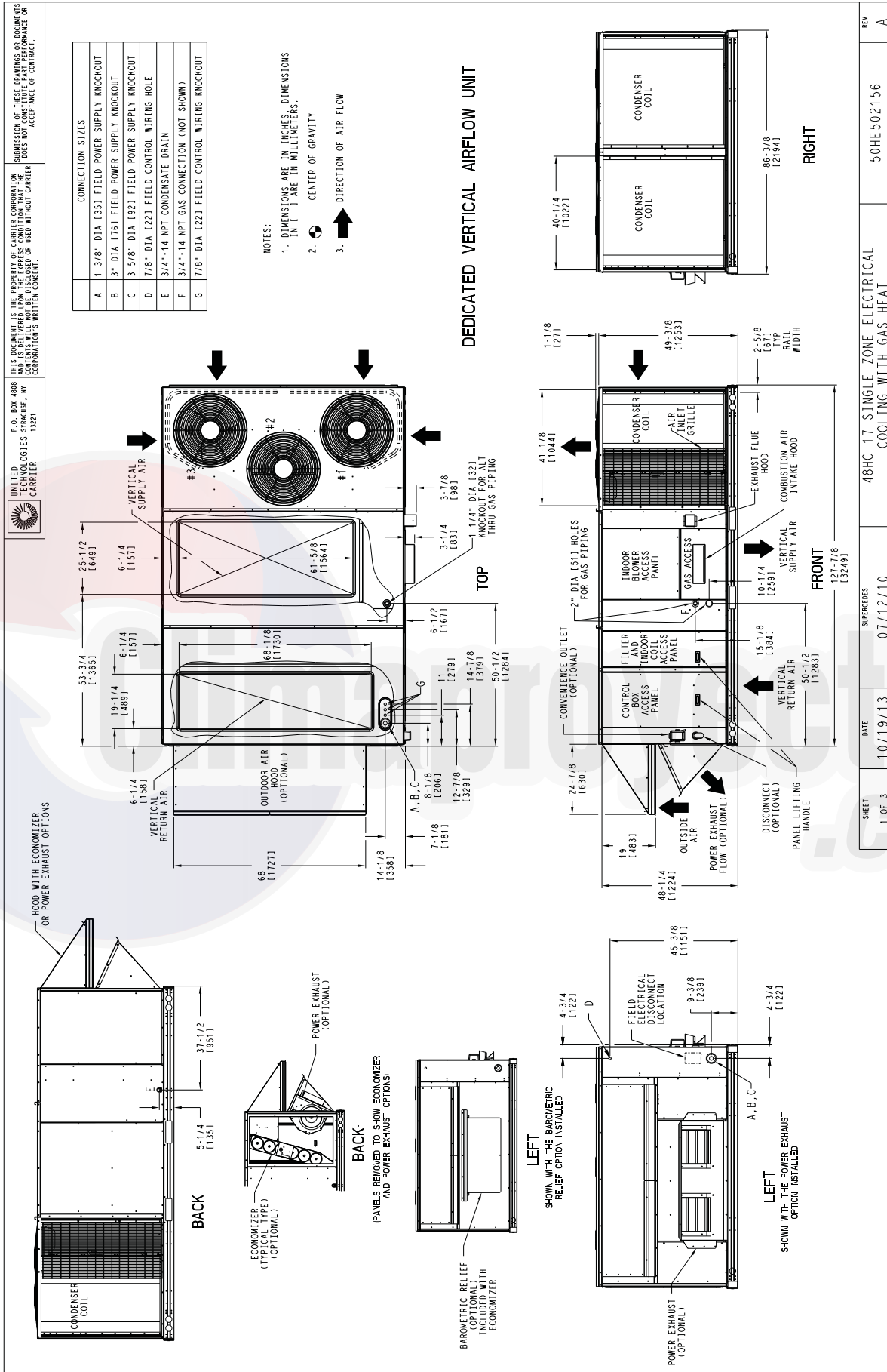

SHEET 1 OF 3

DATE 10/19/13

SUPERCEDES 07/12/10

REV A

50HE502156

48HC 17 SINGLE ZONE ELECTRICAL COOLING WITH GAS HEAT

Fig. 1 - Unit Dimension Drawing - Size 17 Unit - Sheet 1 of 3

DIMENSIONS (cont.)

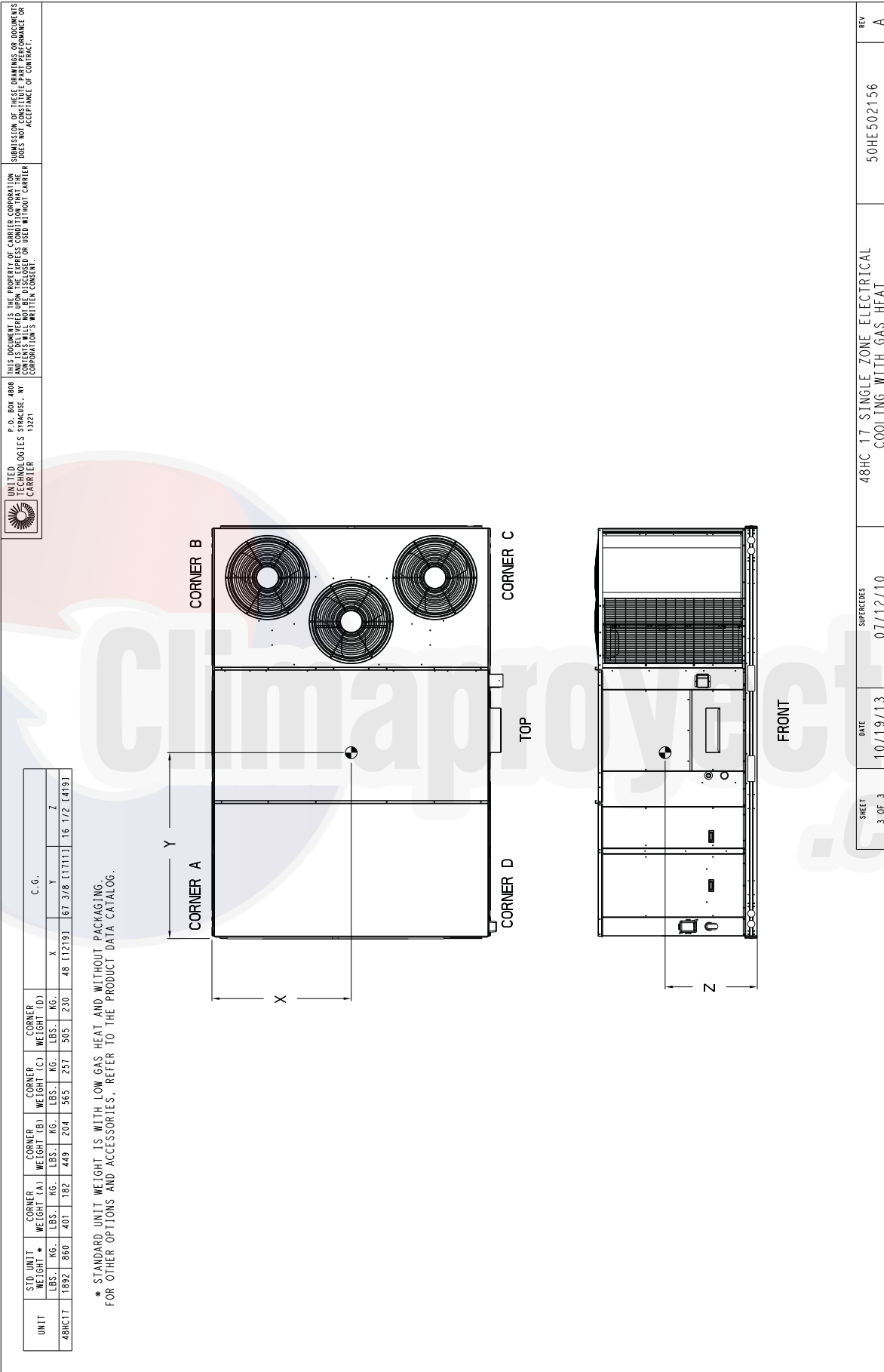

Fig. 3 - Unit Dimension Drawing - Size 17 Unit - Sheet 3 of 3

DIMENSIONS (cont.)

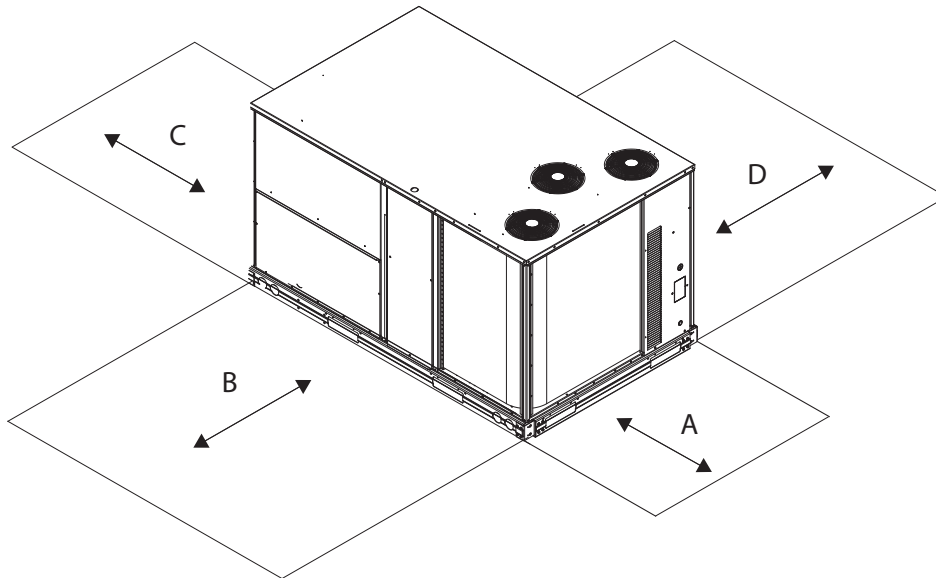

Fig. 4 - Service Clearance

C09051

LOC	DIMENSION	CONDITION
A	36-in	<ul style="list-style-type: none"> Recommended clearance for airflow and service.
B	42-in	<ul style="list-style-type: none"> Recommended clearance for airflow and service.
C	18-in	<ul style="list-style-type: none"> No Convenience Outlet No Economizer. No field-installed disconnect on economizer hood side (factory-installed disconnect installed).
	36-in	<ul style="list-style-type: none"> Convenience Outlet installed. Vertical surface behind servicer is electrically non-conductive (e.g., wood, fiberglass).
	42-in	<ul style="list-style-type: none"> Convenience Outlet installed. Vertical surface behind servicer is electrically conductive (e.g., metal, masonry)
	96-in	<ul style="list-style-type: none"> Economizer and/or Power Exhaust installed. Check for sources of flue products within 10-ft of economizer fresh air intake.
	42-in	<ul style="list-style-type: none"> Recommended clearance for service.

NOTE: Unit not designed to have overhead obstruction. Contact Application Engineering for guidance on any application planning overhead obstruction or for vertical clearances.

DIMENSIONS (cont.)

UNIT SIZE	"A"	ROOF CURB ACCESSORY
17	1'-2" [356.0] 2'-0" [610.0]	CRRFCURB045A00 CRRFCURB046A00

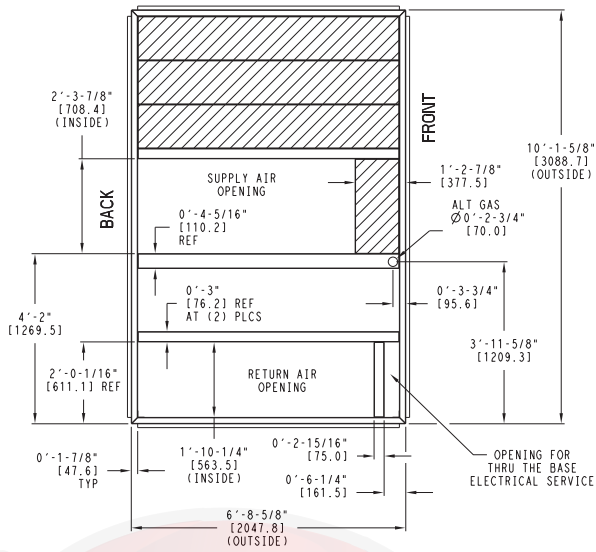

NOTES:

- 1 ROOF CURB ACCESSORY IS SHIPPED UNASSEMBLED.
- 2 DIMENSIONS IN [] ARE IN MILLIMETERS.
- 3 ROOF CURB GALVANIZED STEEL.
- 4 ATTACH DUCTWORK TO CURB (FLANGES ON DUCT REST ON CURB)
- 5 SERVICE CLEARANCE 4 FT ON EACH SIDE

➔ DIRECTION OF AIR FLOW

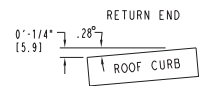
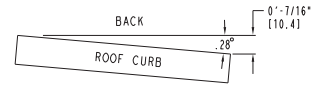

MAX CURB LEVELING TOLERANCES

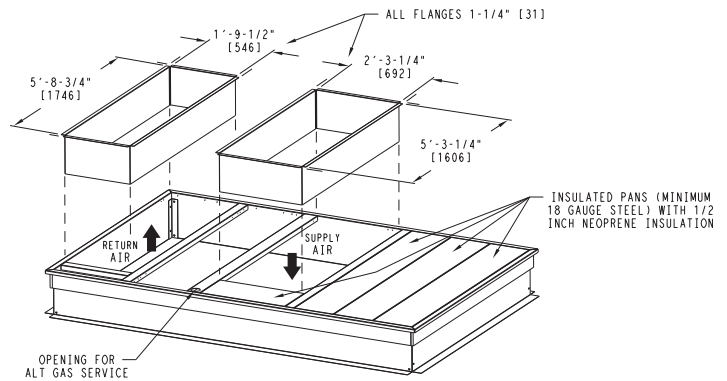
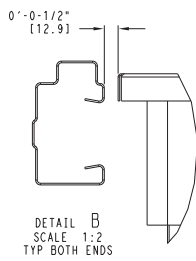
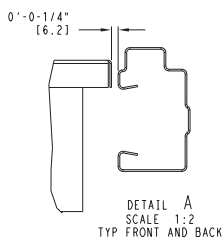
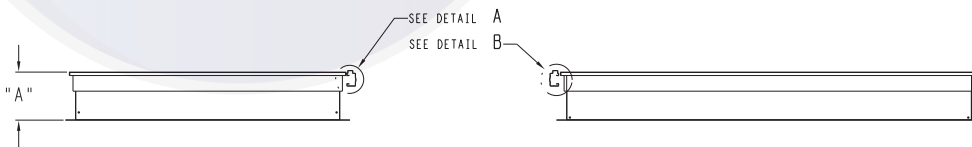
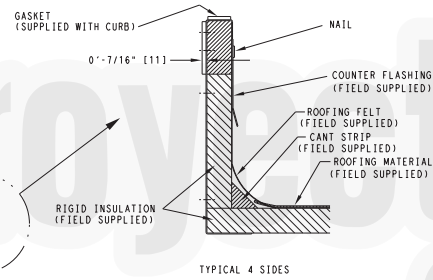
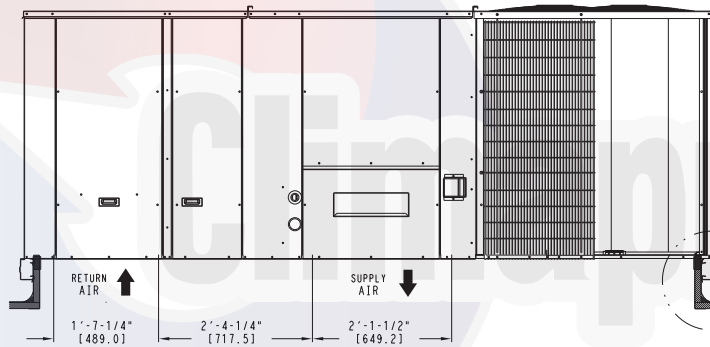

Fig. 5 - Roof Curb Details - Size 17 Unit

C10954

DIMENSIONS (cont.)

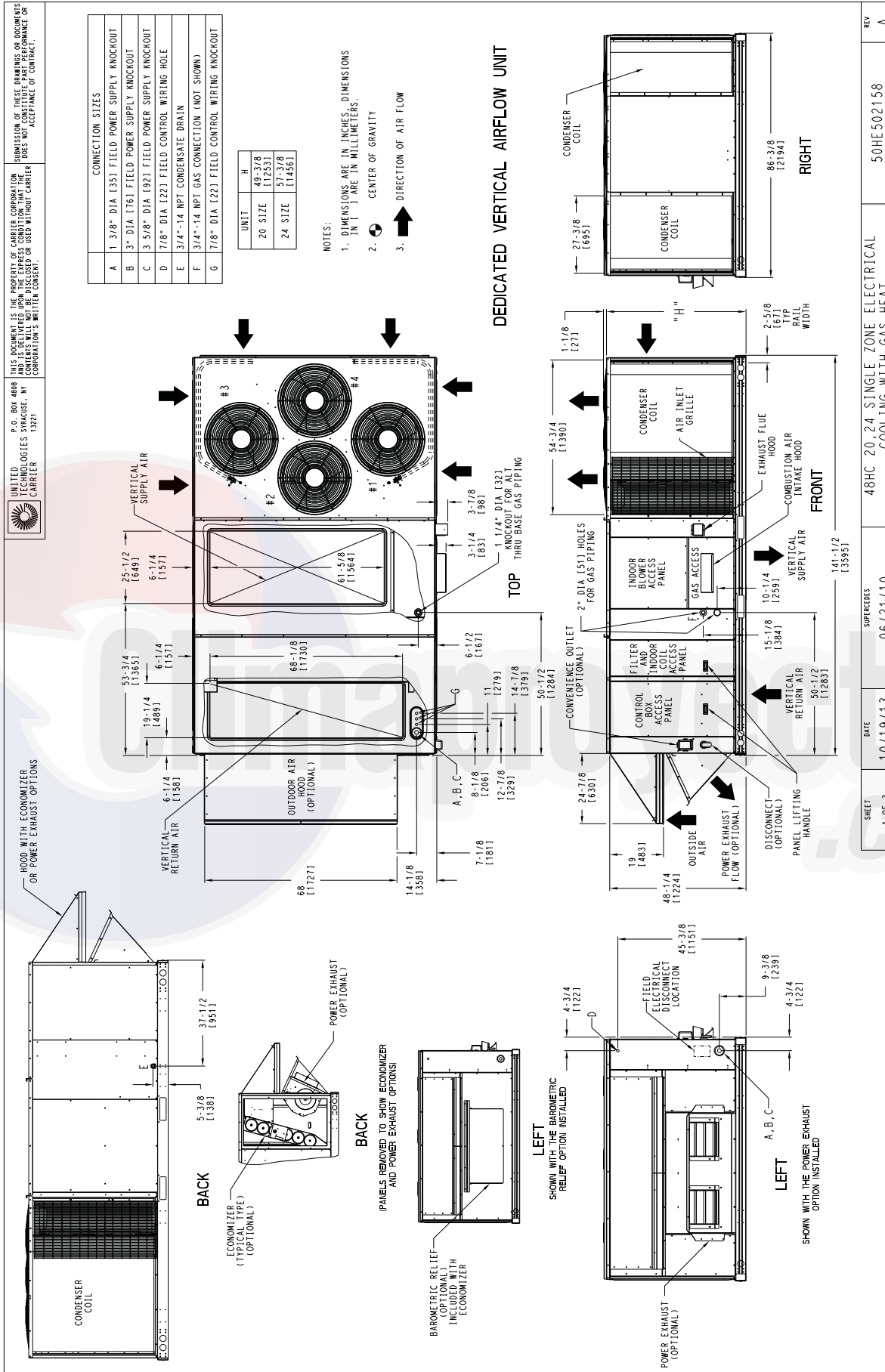

Fig. 6 - Unit Dimension Drawing - Size 20 - 24 Units - Sheet 1 of 3

DIMENSIONS (cont.)

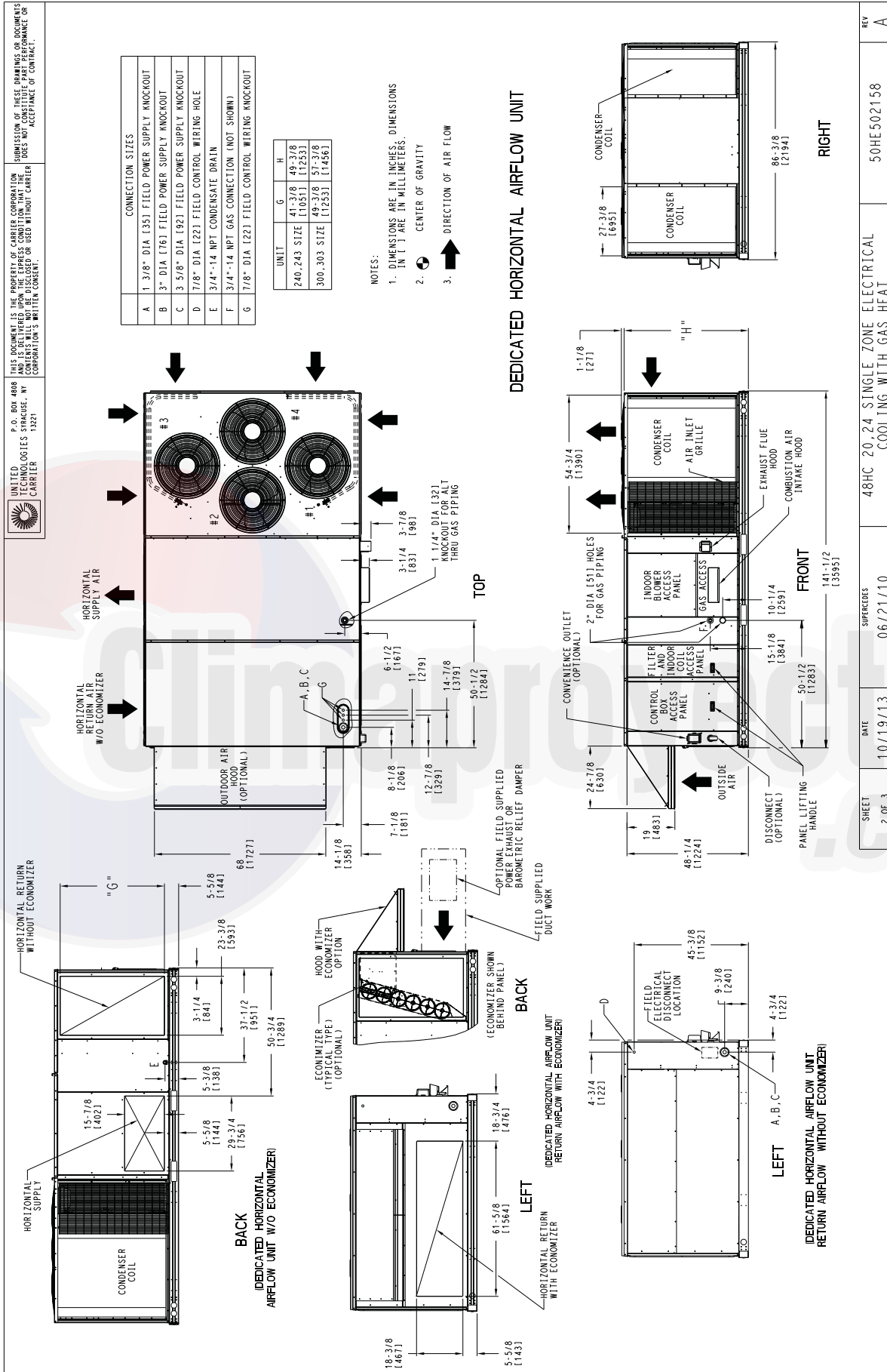
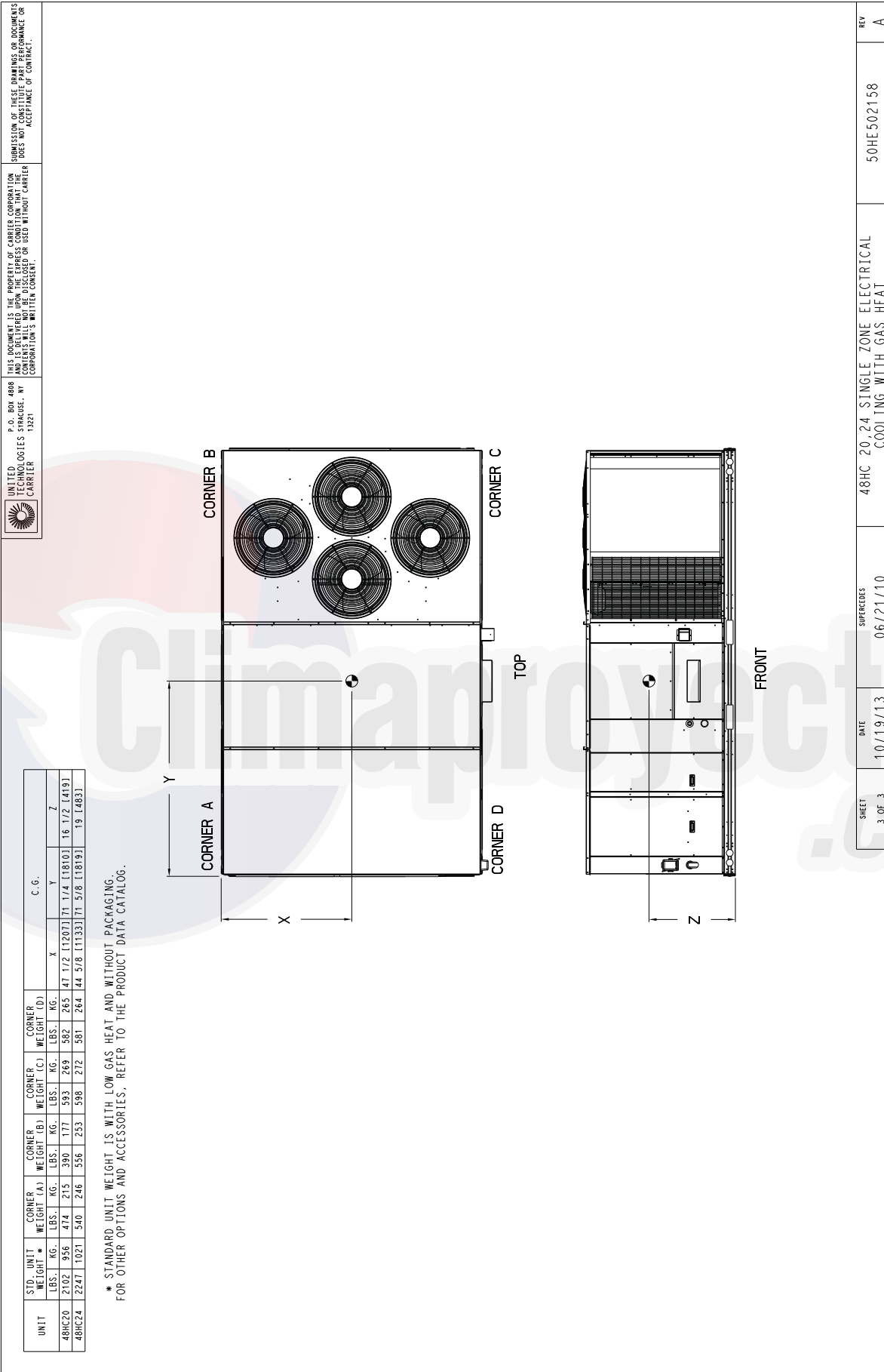

Fig. 7 - Unit Dimension Drawing - Size 20 - 24 Units - Sheet 2 of 3

DIMENSIONS (cont.)



SHEET	DATE	SUPERCEDES	REV
3 OF 3	10/19/13	06/21/10	A

48HC 20, 24 SINGLE ZONE ELECTRICAL
COOLING WITH GAS HEAT

50HE502158

Fig. 8 - Unit Dimension Drawing - Size 20 - 24 Units - Sheet 3 of 3

DIMENSIONS (cont.)

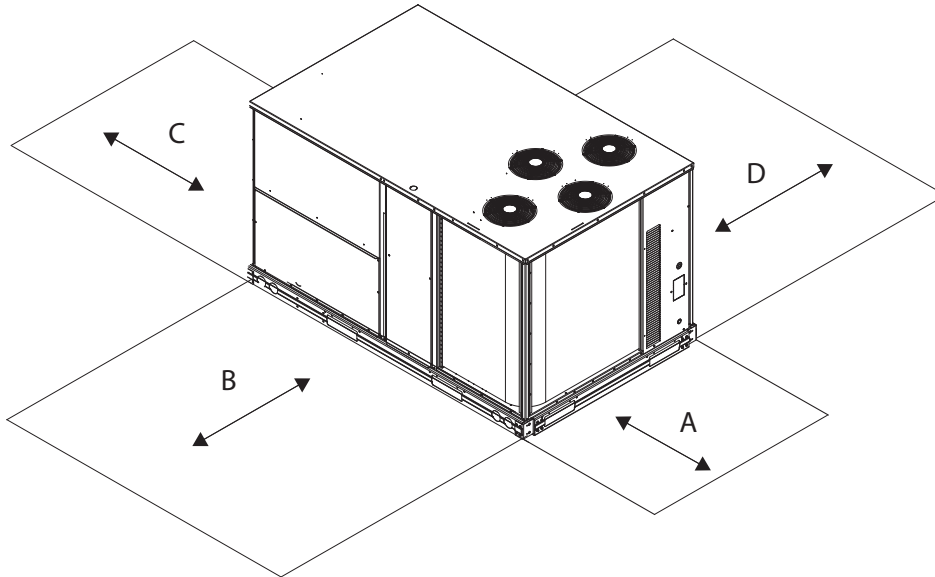

Fig. 9 - Service Clearance

C10579

LOC	DIMENSION	CONDITION
A	36-in	<ul style="list-style-type: none"> • Recommended clearance for airflow and service.
B	42-in	<ul style="list-style-type: none"> • Recommended clearance for airflow and service.
C	18-in	<ul style="list-style-type: none"> • No Convenience Outlet. • No Economizer. • No field-installed disconnect on economizer hood side (factory-installed disconnect installed).
	36-in	<ul style="list-style-type: none"> • Convenience Outlet installed. • Vertical surface behind servicer is electrically non-conductive (e.g., wood, fiberglass).
	42-in	<ul style="list-style-type: none"> • Convenience Outlet installed. • Vertical surface behind servicer is electrically conductive (e.g., metal, masonry)
	96-in	<ul style="list-style-type: none"> • Economizer and/or Power Exhaust installed. • Check for sources of flue products within 10-ft of economizer fresh air intake.
D	42-in	<ul style="list-style-type: none"> • Recommended clearance for service.

NOTE: Unit not designed to have overhead obstruction. Contact Application Engineering for guidance on any application planning overhead obstruction or for vertical clearances.

DIMENSIONS (cont.)

UNIT SIZE	"A"	ROOF CURB ACCESSORY
20, 24	1'-2" [356.0] 2'-0" [610.0]	CRRFCURB047A00 CRRFCURB048A00

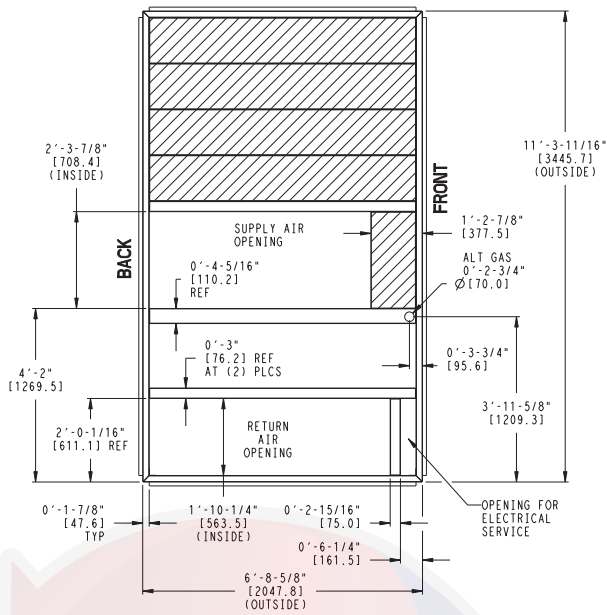

NOTES:

- 1 ROOF CURB ACCESSORY IS SHIPPED UNASSEMBLED.
- 2 DIMENSIONS IN [] ARE IN MILLIMETERS.
- 3 ROOF CURB GALVANIZED STEEL.
- 4 ATTACH DUCTWORK TO CURB (FLANGES ON DUCT REST ON CURB)
- 5 SERVICE CLEARANCE 4 FT ON EACH SIDE

➔ DIRECTION OF AIR FLOW

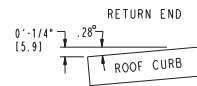
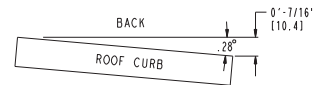

MAX CURB LEVELING TOLERANCES

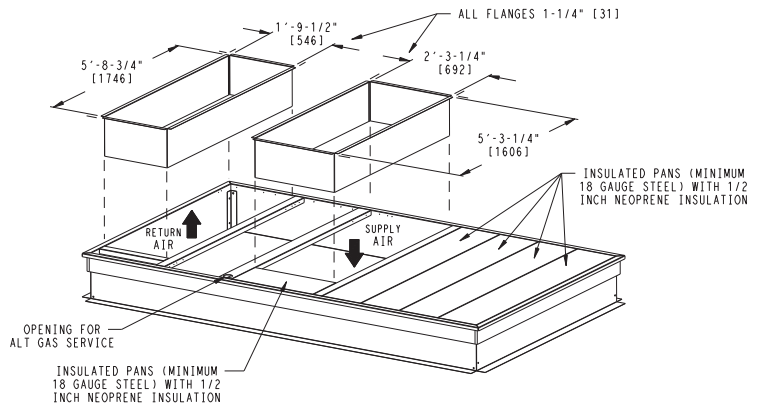
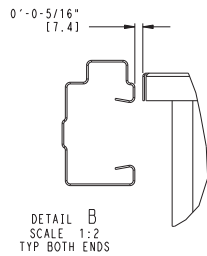
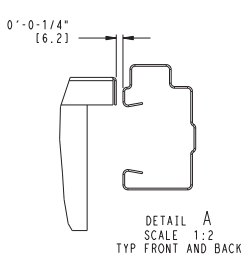
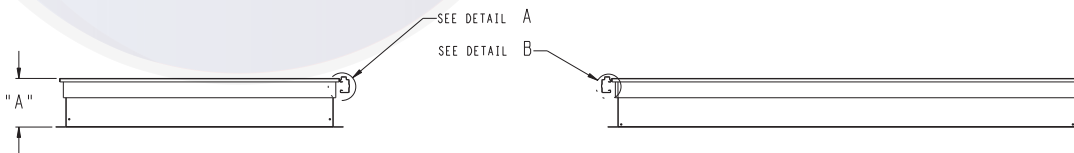
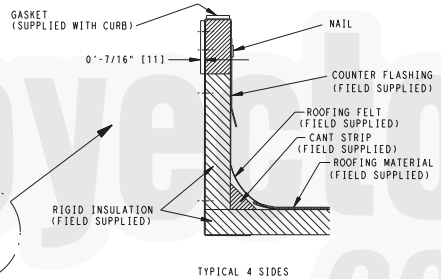
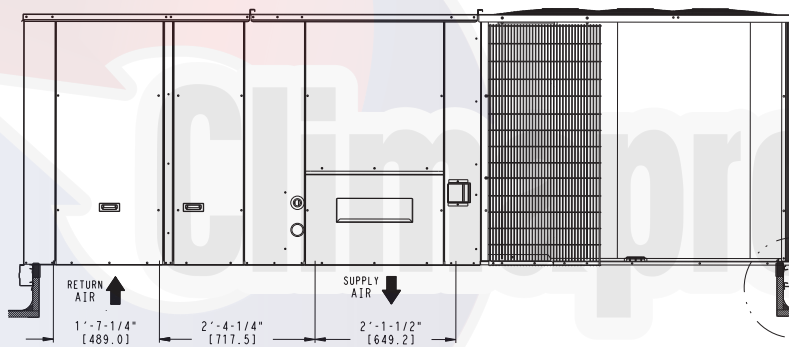

Fig. 10 - Roof Curb Details - Size 20 - 24 Units

C10955

DIMENSIONS (cont.)

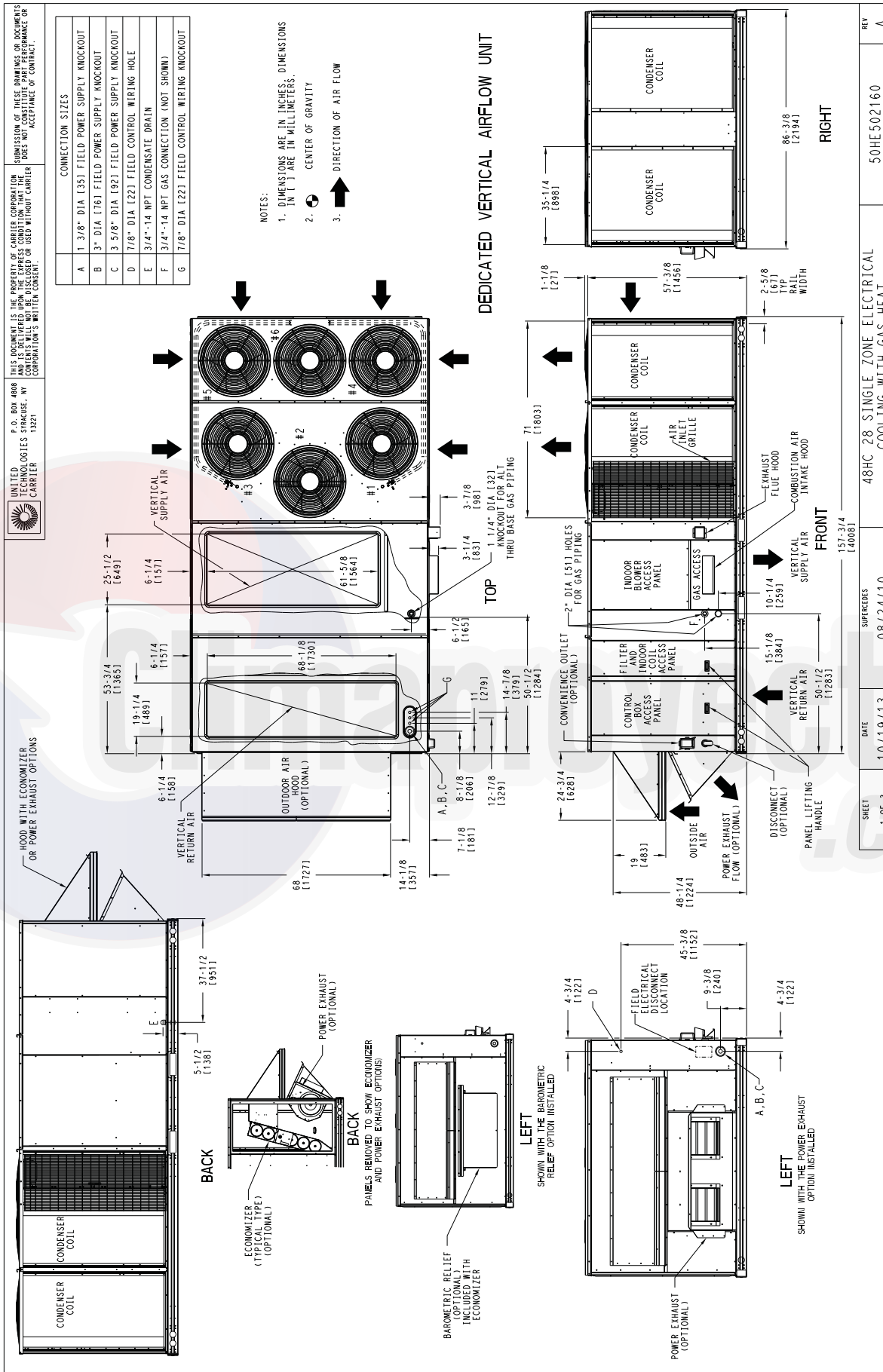

Fig. 11 - Unit Dimension Drawing - Size 28 Unit - Sheet 1 of 3

DIMENSIONS (cont.)

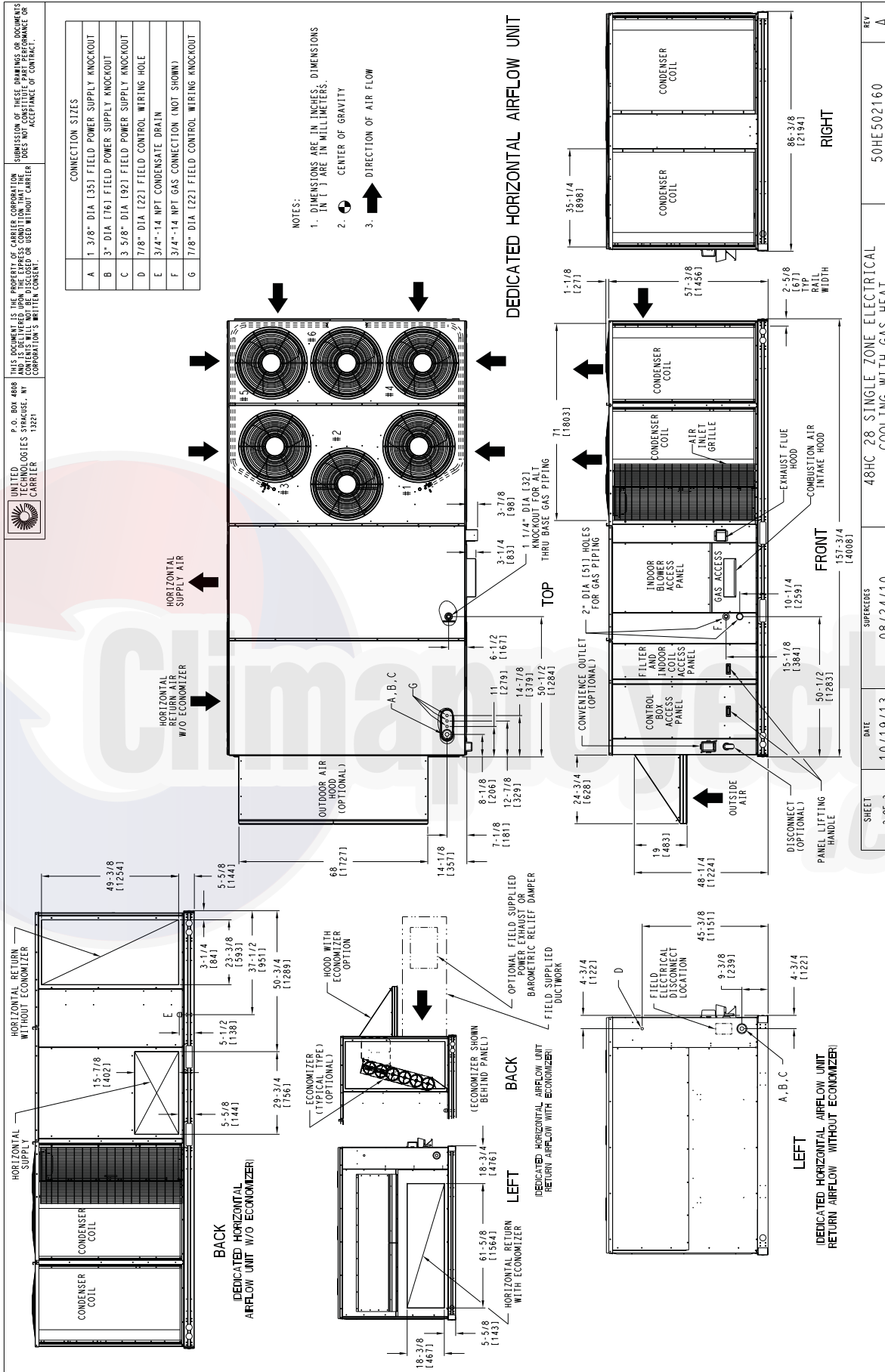

Fig. 12 - Unit Dimension Drawing - Size 28 Unit - Sheet 2 of 3

DIMENSIONS (cont.)

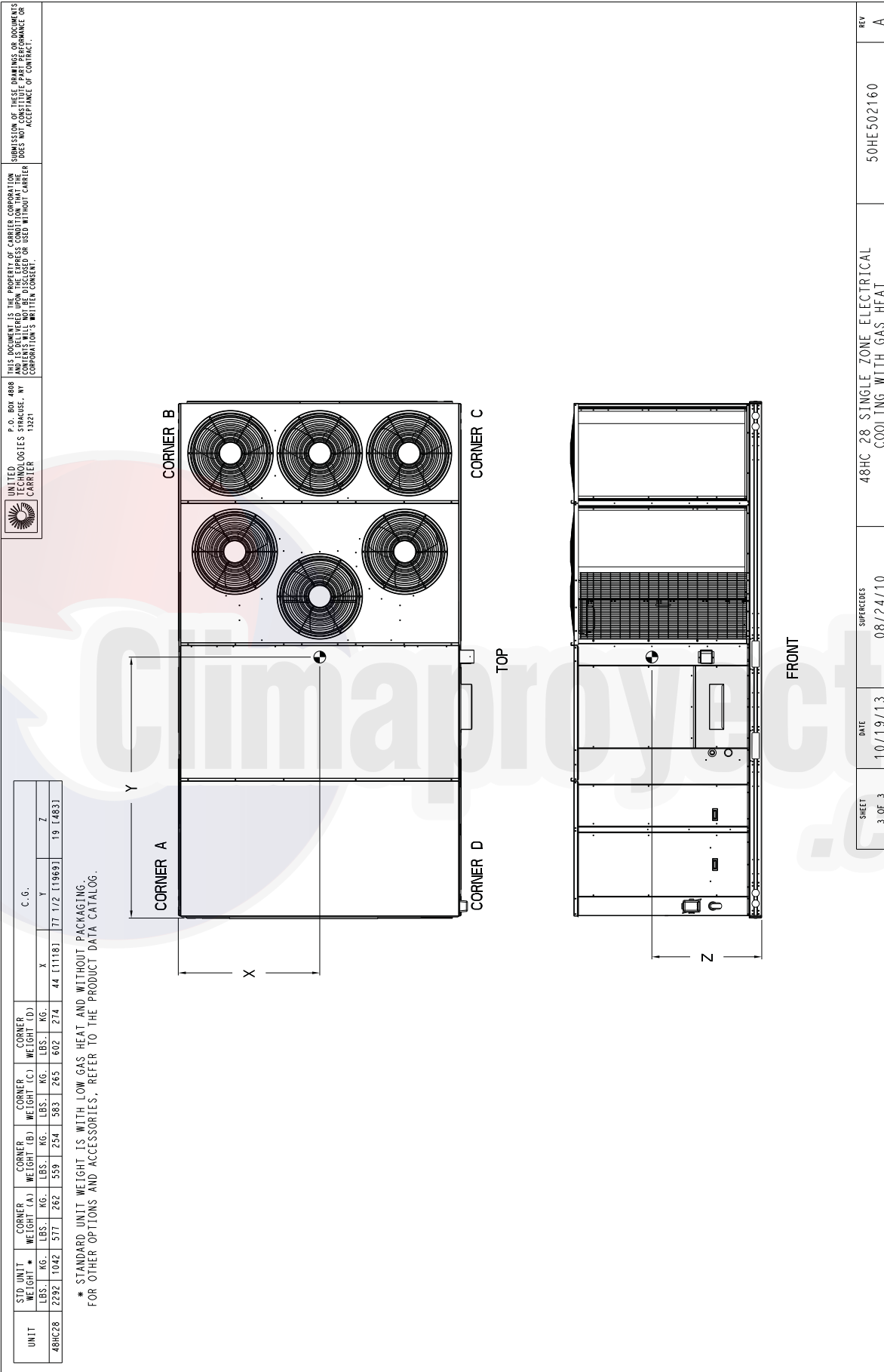

Fig. 13 - Unit Dimension Drawing - Size 28 Unit - Sheet 3 of 3

DIMENSIONS (cont.)

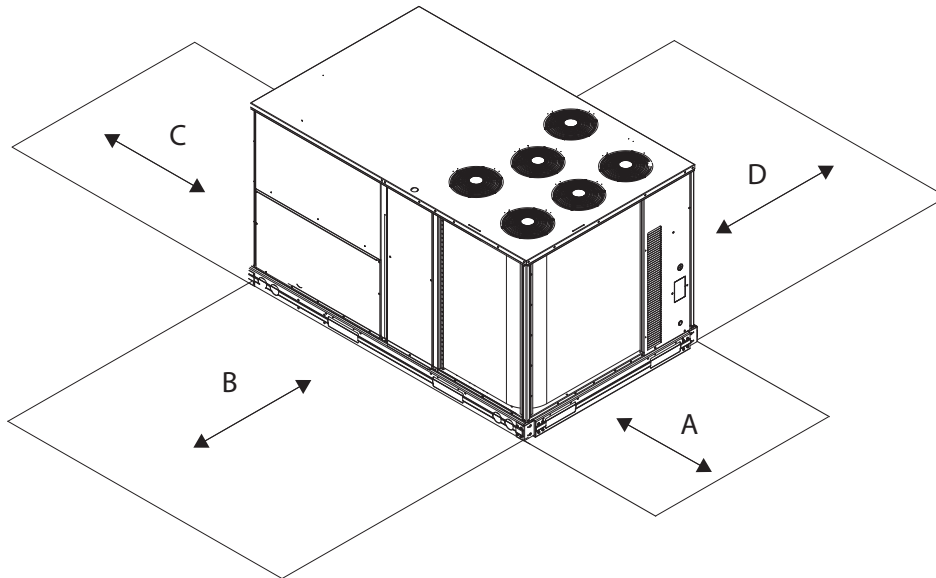

Fig. 14 - Service Clearance

C10998

LOC	DIMENSION	CONDITION
A	36-in	<ul style="list-style-type: none"> • Recommended clearance for airflow and service.
B	42-in	<ul style="list-style-type: none"> • Recommended clearance for airflow and service.
C	18-in	<ul style="list-style-type: none"> • No Convenience Outlet. • No Economizer. • No field-installed disconnect on economizer hood side (factory-installed disconnect installed).
	36-in	<ul style="list-style-type: none"> • Convenience Outlet installed. • Vertical surface behind servicer is electrically non-conductive (e.g., wood, fiberglass).
	42-in	<ul style="list-style-type: none"> • Convenience Outlet installed. • Vertical surface behind servicer is electrically conductive (e.g., metal, masonry)
	96-in	<ul style="list-style-type: none"> • Economizer and/or Power Exhaust installed. • Check for sources of flue products within 10-ft of economizer fresh air intake.
D	42-in	<ul style="list-style-type: none"> • Recommended clearance for service.

NOTE: Unit not designed to have overhead obstruction. Contact Application Engineering for guidance on any application planning overhead obstruction or for vertical clearances.

DIMENSIONS (cont.)

UNIT SIZE	"A"	ROOF CURB ACCESSORY
28	1'-2" [356.0] 2'-0" [610.0]	CRRFCURB049A00 CRRFCURB050A00

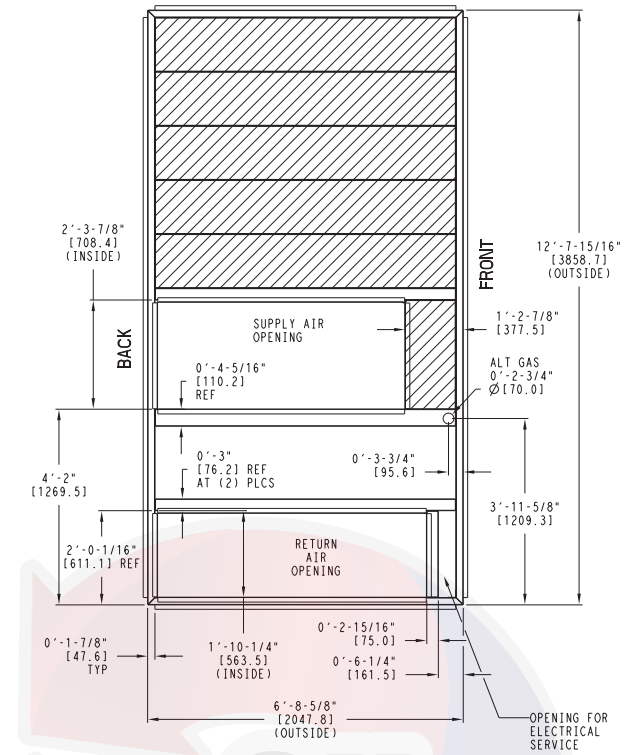

- NOTES:
- 1 ROOF CURB ACCESSORY IS SHIPPED UNASSEMBLED.
 - 2 BOLT HEADS TO BE ON INSIDE OF FLANGE. CLEARANCE IS (11) 0'-0-7/16" TYP ALL CORNERS.
 - 3 DIMENSIONS IN () ARE IN MILLIMETERS.
 - 4 ROOF CURB GALVANIZED STEEL.
 - 5 ATTACH DUCTWORK TO CURB (FLANGES ON DUCT REST ON CURB)
 - 6 SERVICE CLEARANCE 4 FT ON EACH SIDE
 - 7 GAS SERVICE PLATE IS PART OF A SEPARATELY SHIPPED ACCESSORY PACKAGE.
 - 8 GAS SERVICE PLATE CAN BE USED WITH EITHER ACCESSORY ROOFCURB.

➔ DIRECTION OF AIR FLOW

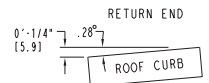
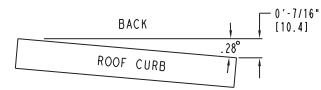

MAX CURB LEVELING TOLERANCES

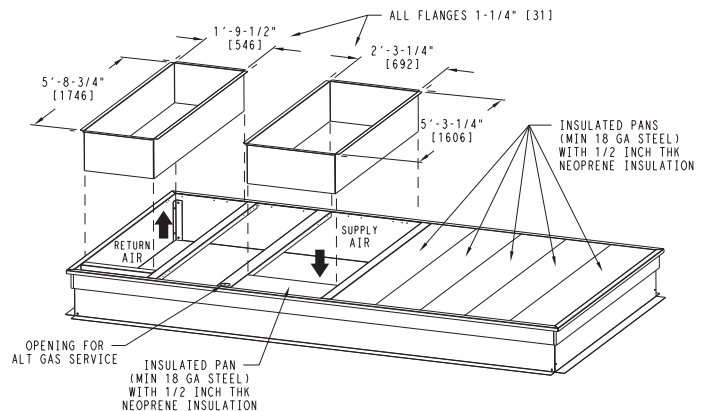
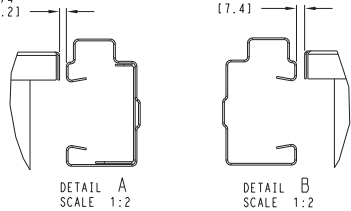
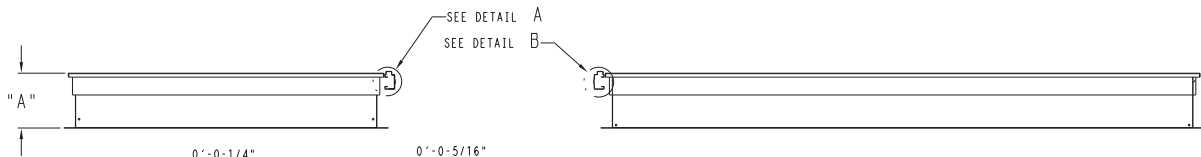
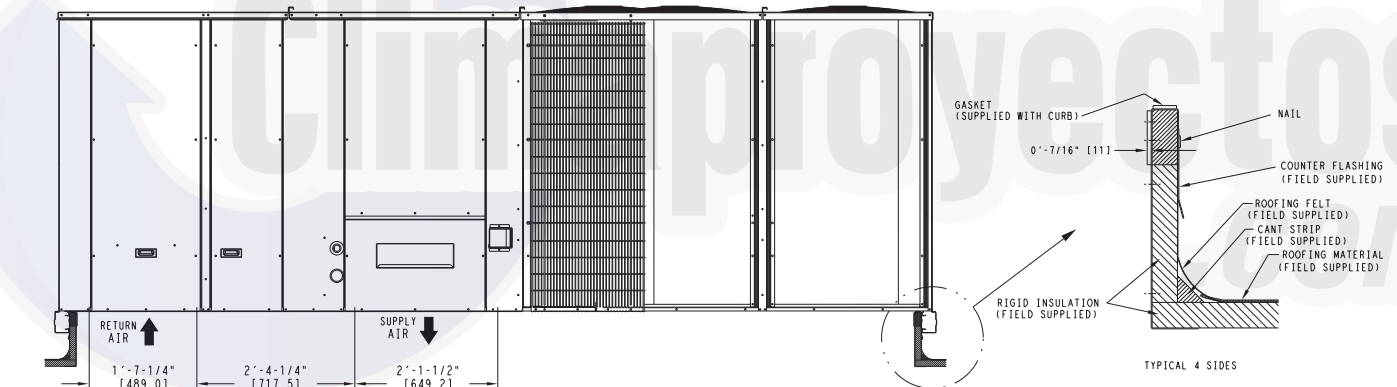

Fig. 15 - Roof Curb Details - Size 28 Unit

C10956

OPTIONS AND ACCESSORIES WEIGHT ADDERS

BASE UNIT WITH OPTIONS AND ACCESSORIES (Weight Adders)	MAX WEIGHT ADD							
	48HC**17		48HC**20		48HC**24		48HC**28	
	lb	kg	lb	kg	lb	kg	lb	kg
Humidi-MiZer® System*	110	50	120	55	120	55	120	55
Base Unit Operating Weight	1892	858	2102	953	2247	1019	2292	1040
Power Exhaust	125	57	125	57	125	57	125	57
EconoMi\$er (IV, X, or 2)	170	77	170	77	170	77	195	88
Copper Tube/Fin Evaporator Coil	110	50	110	50	135	61	161	73
Low Gas Heat	85	39	85	39	85	39	85	39
Medium Gas Heat	90	41	90	41	90	41	90	41
High Gas Heat	113	51	113	51	113	51	113	51
Flue Discharge Deflector	7	3	7	3	7	3	7	3
Roof Curb 14-in (356 mm)	240	109	240	109	240	109	255	116
Roof Curb 24-in (610 mm)	340	154	340	154	340	154	355	161
Louvered Hail Guard	60	27	60	27	120	54	150	68
CO ₂ sensor	5	2	5	2	5	2	5	2
Return Smoke Detector	5	2	5	2	5	2	5	2
Supply Smoke Detector	5	2	5	2	5	2	5	2
Fan/Filter Status Switch	2	1	2	1	2	1	2	1
Non-Fused Disconnect	15	7	15	7	15	7	15	7
HACR Circuit Breaker	15	7	15	7	15	7	15	7
Powered Convenience Outlet	35	16	35	16	35	16	35	16
Non-Powered Convenience Outlet	5	2	5	2	5	2	5	2
Enthalpy Sensor	2	1	2	1	2	1	2	1
Differential Enthalpy Sensor	3	1	3	1	3	1	3	1
Two Position Motorized Damper	50	23	50	23	50	23	65	29
Manual Damper	35	16	35	16	35	16	40	18
Field Filter Track 4-in (102 mm)	12	5	12	5	12	5	12	5
Motormaster® Controller	35	16	35	16	35	16	35	16
Medium Static Motor/Drive	5	2	6	3	6	3	6	3
High Static Motor/Drive	11	5	12	5	16	7	16	7
Barometric Relief Hood (Horizontal)	25	11	25	11	25	11	25	11
SAV™ System with VFD	20	9	20	9	20	9	20	9

* For Humidi-MiZer system add Motormaster Controller

APPLICATION/SELECTION DATA

Min operating ambient temp (cooling):

In mechanical cooling mode, your Carrier rooftop unit can safely operate down to an outdoor ambient temperature of 35°F (2°C). It is possible to provide cooling at lower outdoor ambient temperatures by using less outside air, economizers, and/or accessory low ambient kits.

Max operating ambient temp (cooling):

The maximum operating ambient temperature for cooling mode is 125°F (52°C). While cooling operation above 125°F (52°C) may be possible, it could cause either a reduction in performance, reliability, or a protective action by the unit's internal safety devices.

Min mixed air temp (heating):

Using the factory settings, the minimum temperatures for the mixed air (the combined temperature of the warm return air and the cold outdoor air) entering the dimpled, gas heat exchangers are:

<u>Aluminized</u>	<u>Stainless Steel</u>
50°F (10°C) continuous	40°F (4°C) continuous
45°F (7°C) intermittent	35°F (2°C) intermittent

Operating at lower mixed-air temperatures may be possible, if a field-supplied, outdoor air thermostat initiates both heat stages when the temperature is less than the minimum temperatures listed above. Please contact your local Carrier representative for assistance.

Min and max airflow (heating and cooling):

To maintain safe and reliable operation of your rooftop, operate within the heating airflow limits during heating mode and cooling airflow limits during cooling mode. Operating above the max may cause blow-off, undesired airflow noise, or airflow related problems with the rooftop unit. Operating below the min may cause problems with coil freeze-up and unsafe heating operation. For proper minimum and maximum CFM values see Table 5.

Heating-to-cooling changeover:

Your unit will automatically change from heating to cooling mode when using a thermostat with an auto-change-over feature.

Airflow:

All units are draw-through in cooling mode and blow-through in heating mode.

Outdoor air application strategies:

Economizers reduce operating expenses and compressor run time by providing a free source of cooling and a means of ventilation to match application changing needs. In fact, they should be considered for most applications. Also, consider the various economizer control methods and their benefits, as well as sensors required to accomplish your application goals. Please contact your local Carrier representative for assistance.

Motor limits, break horsepower (BHP):

Due to internal design of Carrier units, the air path, and specially designed motors, the full horsepower (maximum continuous BHP) band, as listed in Physical Data Table Cooling, can be used with the utmost confidence. There is no need for extra safety factors, as Carrier motors are designed and rigorously tested to use the entire, listed BHP range without either nuisance tripping or premature motor failure.

Propane heating:

Propane has different physical qualities than natural gas. As a result, Propane requires different fuel to air mixture. To optimize the fuel/air mixture for Propane, Carrier sells different burner orifices in an easy to install accessory kit. To select the correct burner orifices or determine the heat capacity for an Propane application, use either the selection software or the unit's service manual.

High altitude heating:

High altitudes have less oxygen, which affects the fuel/air mixture in heat exchangers. In order to maintain a proper fuel/air mixture, heat exchangers operating in altitudes above 2000 ft (610 m) require different orifices. To select the correct burner orifices or determine the heat capacity for a high altitude application, use either the selection software or the unit's service manual.

High altitudes have less oxygen, which means heat exchangers need less fuel. The new gas orifices in this field-installed kit make the necessary adjustment for high altitude applications. They restore the optimal fuel to air mixture and maintain healthy combustion on altitudes above 2000 ft (610 m).

NOTE: Typical natural gas heating value ranges from 975 to 1050 Btu/ft³ at sea level nationally. The heating value goes down approximately 1.7% per every thousand feet elevation. Standard factory orifices can typically be used up to 2000 ft (610 m) elevation without any operational issues.

APPLICATION/SELECTION DATA (cont.)

Sizing a rooftop

Bigger isn't necessarily better. While an air conditioner needs to have enough capacity to meet the design loads, it doesn't need excess capacity. In fact, excess capacity typically results in very poor part load performance and humidity control.

Using higher design temperatures than ASHRAE recommends for your location, adding "safety factors" to the calculated load, are all signs of oversizing air conditioners. Oversizing the air conditioner leads to poor humidity control, reduced efficiency, higher utility bills, larger indoor temperature swings, excessive noise, and increased wear and tear on the air conditioner.

Rather than oversizing an air conditioner, engineers should "right-size" or even slightly undersize air conditioners. Correctly sizing an air conditioner controls humidity better; promotes efficiency; reduces utility bills; extends equipment life, and maintains even, comfortable temperatures. Please contact your local Carrier representative for assistance.

Low ambient applications

The optional Carrier economizer can adequately cool your space by bringing in fresh, cool outside air. In fact, when so equipped, accessory low-ambient kit may not be necessary. In low ambient conditions, unless the outdoor air is excessively humid or contaminated, economizer-based "free cooling" is the preferred less costly and energy conscious method.

In low ambient applications where outside air might not be desired (such as contaminated or excessively humid outdoor environments), your Carrier rooftop can operate to ambient temperatures down to -20°F (-29°C) using the recommended field-installed accessory Motormaster® low ambient controller or down to 0°F (-18°C) with the factory-installed low ambient controller option.

Application/Selection Option

Selection software by Carrier saves time by performing many of the steps above. Contact your Carrier sales representative for assistance.

Staged Air Volume (SAV™) with Variable Frequency Drive (VFD)

Carrier's Staged Air Volume (SAV) system utilizes a Variable Frequency Drive (VFD) to automatically adjust the indoor fan motor speed in sequence with the units cooling operation. Per ASHRAE 90.1 standard, during the first stage of cooling operation the VFD will adjust the fan motor to provide 66% of the total cfm established for the unit. When a call for the second stage of cooling is required, the VFD will allow the total cfm for the unit established (100%). During the heating mode, the VFD will allow total design cfm (100%) operation and during the ventilation mode the VFD will allow operation to 66% of total cfm.

The VFD used in Carrier's SAV system has soft start capabilities to slowly ramp up the speeds, thus eliminating any high inrush air volume during initial start-up. It also has internal over current protection for the fan motor and a field-installed display kit that allows adjustment and in depth diagnostics of the VFD.

This SAV system is available on models with 2-stage cooling operation with electrical mechanical or RTU Open (multi Protocol) controls. Both space sensor and conventional thermostats controls can be used to provide accurate control in any application.

The SAV system is very flexible for initial fan performance set up and adjustment. The standard factory shipped VFD is pre-programmed to automatically stage the fan speed between the first and second stage of cooling. The unit fan performance static pressure and cfm can be easily adjusted using the traditional means of pulley adjustments. The other means to adjust the unit static and cfm performance is to utilize the field-installed display module and adjust the frequency and voltage in the VFD to required performance requirements. In either case, once set up the VFD will automatically adjust the speed between the cooling stage operations.

Table 8 – COOLING CAPACITIES

2-STAGE COOLING

15 TONS

48HC*D17			AMBIENT TEMPERATURE (F)															
			85			95			105			115			125			
			EAT (db)			EAT (db)			EAT (db)			EAT (db)			EAT (db)			
			75	80	85	75	80	85	75	80	85	75	80	85	75	80	85	
4500 CFM	EAT (wb)	58	TC	158.3	158.3	179.2	152.6	152.6	172.9	146.6	146.6	166.1	140.2	140.2	158.8	133.2	133.2	150.8
			SHC	137.3	158.3	179.2	132.4	152.6	172.9	127.2	146.6	166.1	121.6	140.2	158.8	115.5	133.2	150.8
		62	TC	166.8	166.8	169.0	159.5	159.5	165.6	151.8	151.8	161.9	143.6	143.6	157.9	134.9	134.9	153.4
			SHC	123.1	146.1	169.0	119.7	142.6	165.6	116.1	139.0	161.9	112.3	135.1	157.9	108.2	130.8	153.4
		67	TC	182.9	182.9	182.9	174.9	174.9	174.9	166.3	166.3	166.3	157.2	157.2	157.2	147.6	147.6	147.6
			SHC	100.0	123.1	146.1	96.7	119.8	142.8	93.2	116.3	139.4	89.7	112.7	135.7	85.9	108.9	131.9
		72	TC	200.5	200.5	200.5	191.6	191.6	191.6	182.2	182.2	182.2	172.2	172.2	172.2	161.7	161.7	161.7
			SHC	76.1	99.5	122.8	72.9	96.2	119.5	69.5	92.8	116.1	66.0	89.3	112.5	62.4	85.6	108.8
		76	TC	-	215.4	215.4	-	205.8	205.8	-	195.6	195.6	-	184.8	184.8	-	173.6	173.6
			SHC	-	80.2	105.0	-	77.1	101.7	-	73.7	98.2	-	70.2	94.5	-	66.7	90.7
5250 CFM	EAT (wb)	58	TC	166.7	166.7	188.8	160.6	160.6	181.9	154.0	154.0	174.4	147.0	147.0	166.5	139.5	139.5	157.9
			SHC	144.6	166.7	188.8	139.3	160.6	181.9	133.6	154.0	174.4	127.6	147.0	166.5	121.0	139.5	157.9
		62	TC	172.0	172.0	185.1	164.3	164.3	181.2	156.3	156.3	177.0	147.8	147.8	172.4	139.6	139.6	164.3
			SHC	132.5	158.8	185.1	128.9	155.1	181.2	125.0	151.0	177.0	120.9	146.6	172.4	114.9	139.6	164.3
		67	TC	188.3	188.3	188.3	179.7	179.7	179.7	170.7	170.7	170.7	161.0	161.0	161.0	150.9	150.9	150.9
			SHC	106.1	132.7	159.3	102.8	129.3	155.9	99.3	125.8	152.4	95.6	122.1	148.6	91.7	118.2	144.7
		72	TC	206.1	206.1	206.1	196.7	196.7	196.7	186.7	186.7	186.7	176.2	176.2	176.2	165.3	165.3	165.3
			SHC	78.8	105.6	132.5	75.5	102.3	129.1	72.1	98.8	125.6	68.5	95.2	121.9	64.8	91.4	118.0
		76	TC	-	221.2	221.2	-	211.0	211.0	-	200.3	200.3	-	189.0	189.0	-	177.2	177.2
			SHC	-	83.6	111.7	-	80.3	108.2	-	76.9	104.6	-	73.3	100.9	-	69.7	97.1
6000 CFM	EAT (wb)	58	TC	173.8	173.8	196.8	167.2	167.2	189.4	160.2	160.2	181.4	152.7	152.7	173.0	144.7	144.7	163.8
			SHC	150.8	173.8	196.8	145.1	167.2	189.4	139.0	160.2	181.4	132.5	152.7	173.0	125.5	144.7	163.8
		62	TC	176.3	176.3	199.5	168.5	168.5	194.9	160.5	160.5	188.9	152.9	152.9	179.9	144.8	144.8	170.4
			SHC	140.9	170.2	199.5	136.9	165.9	194.9	132.1	160.5	188.9	125.8	152.9	179.9	119.2	144.8	170.4
		67	TC	192.3	192.3	192.3	183.4	183.4	183.4	173.9	173.9	173.9	164.0	164.0	164.0	153.4	153.4	156.9
			SHC	112.0	142.0	172.0	108.5	138.5	168.5	104.9	134.9	164.8	101.2	131.1	161.0	97.2	127.1	156.9
		72	TC	210.4	210.4	210.4	200.6	200.6	200.6	190.2	190.2	190.2	179.3	179.3	179.3	167.9	167.9	167.9
			SHC	81.2	111.4	141.7	77.9	108.0	138.2	74.4	104.5	134.6	70.7	100.8	130.8	67.0	96.9	126.9
		76	TC	-	225.6	225.6	-	215.0	215.0	-	203.8	203.8	-	192.1	192.1	-	180.0	180.0
			SHC	-	86.7	117.9	-	83.3	114.5	-	79.9	110.8	-	76.3	107.1	-	72.6	103.2
6750 CFM	EAT (wb)	58	TC	179.8	179.8	203.7	172.9	172.9	195.8	165.5	165.5	187.4	157.5	157.5	178.4	149.0	149.0	168.8
			SHC	156.0	179.8	203.7	150.0	172.9	195.8	143.5	165.5	187.4	136.7	157.5	178.4	129.3	149.0	168.8
		62	TC	180.5	180.5	210.7	173.0	173.0	203.6	165.6	165.6	194.9	157.7	157.7	185.5	149.1	149.1	175.5
			SHC	147.6	179.2	210.7	142.4	173.0	203.6	136.3	165.6	194.9	129.8	157.7	185.5	122.8	149.1	175.5
		67	TC	195.6	195.6	195.6	186.2	186.2	186.2	176.5	176.5	176.8	166.2	166.2	172.7	155.4	155.4	168.4
			SHC	117.5	150.8	184.1	114.0	147.3	180.5	110.4	143.6	176.8	106.5	139.6	172.7	102.4	135.4	168.4
		72	TC	213.8	213.8	213.8	203.6	203.6	203.6	192.9	192.9	192.9	181.6	181.6	181.6	169.9	169.9	169.9
			SHC	83.5	117.0	150.5	80.1	113.5	147.0	76.5	109.9	143.3	72.8	106.1	139.4	69.1	102.3	135.5
		76	TC	-	229.1	229.1	-	218.1	218.1	-	206.6	206.6	-	194.6	194.6	-	182.1	182.1
			SHC	-	89.6	124.0	-	86.2	120.5	-	82.7	116.8	-	79.0	113.0	-	75.2	109.0
7500 CFM	EAT (wb)	58	TC	185.1	185.1	209.6	177.7	177.7	201.3	170.0	170.0	192.5	161.6	161.6	183.0	152.8	152.8	173.0
			SHC	160.6	185.1	209.6	154.2	177.7	201.3	147.5	170.0	192.5	140.2	161.6	183.0	132.5	152.8	173.0
		62	TC	185.2	185.2	218.0	177.9	177.9	209.3	170.1	170.1	200.2	161.8	161.8	190.4	152.9	152.9	179.9
			SHC	152.5	185.2	218.0	146.4	177.9	209.3	140.0	170.1	200.2	133.2	161.8	190.4	125.8	152.9	179.9
		67	TC	198.1	198.1	198.1	188.6	188.6	192.1	178.6	178.6	188.1	168.1	168.1	183.8	157.2	157.2	179.1
			SHC	122.8	159.3	195.9	119.2	155.7	192.1	115.5	151.8	188.1	111.5	147.7	183.8	107.3	143.2	179.1
		72	TC	216.6	216.6	216.6	206.1	206.1	206.1	195.1	195.1	195.1	183.5	183.5	183.5	171.6	171.6	171.6
			SHC	85.6	122.3	159.0	82.2	118.8	155.5	78.6	115.2	151.7	74.9	111.3	147.8	71.1	107.4	143.8
		76	TC	-	231.9	231.9	-	220.7	220.7	-	208.9	208.9	-	196.5	196.5	-	183.8	183.8
			SHC	-	92.4	129.9	-	88.9	126.3	-	85.4	122.6	-	81.6	118.7	-	77.8	114.6

NOTE: See Minimum–Maximum Airflow Ratings in Table 5. Do not operate outside these limits.

LEGEND:

- Do not operate
- Cfm - Cubic feet per minute (supply air)
- EAT (db) - Entering Air Temperature (dry bulb)
- EAT (wb) - Entering Air Temperature (wet bulb)
- SHC - Sensible Heat Capacity (1000 Btuh) Gross
- TC - Total Capacity (1000 Btuh) Gross

48HC*E17 (15 TONS) – UNIT WITH HUMIDI-MIZER IN SUBCOOLING MODE										
Temp (F) Air Ent Condenser (Edb)		AIR ENTERING EVAPORATOR – CFM								
		4,500			6,000			7,500		
		Air Entering Evaporator – Ewb (F)								
		72	67	62	72	67	62	72	67	62
75	TC	202.9	184.6	166.2	213.7	194.6	175.4	222.3	202.5	182.7
	SHC	91.9	112.4	132.9	106.1	126.4	146.8	117.5	137.7	158.0
	kW	10.19	10.12	9.78	10.51	10.19	9.95	10.61	10.36	10.12
85	TC	189.8	171.8	153.8	201.0	182.2	163.3	209.9	190.4	170.8
	SHC	75.9	101.0	126.2	91.2	116.3	141.3	103.4	128.4	153.5
	kW	11.57	11.49	11.15	11.88	11.56	11.32	11.98	11.73	11.49
95	TC	176.7	159.1	141.4	188.3	169.7	151.2	197.5	178.2	159.0
	SHC	59.8	89.7	119.6	76.2	106.1	135.9	89.4	119.2	149.0
	kW	12.87	12.81	12.47	13.20	12.88	12.64	13.30	13.05	12.81
105	TC	163.6	146.3	129.0	175.6	157.3	139.1	185.1	166.1	147.1
	SHC	43.8	78.4	112.9	61.3	95.9	130.4	75.3	109.9	144.4
	kW	14.05	14.00	13.65	14.39	14.07	13.82	14.40	14.24	14.00
115	TC	150.5	133.5	116.5	162.9	144.9	127.0	172.7	154.0	135.3
	SHC	27.7	67.0	106.3	46.4	85.7	125.0	61.3	100.6	133.4
	kW	15.44	15.36	15.02	15.75	15.43	15.19	15.85	15.60	15.36
125	TC	137.4	120.8	104.1	150.2	132.5	114.9	160.3	141.9	123.5
	SHC	11.7	55.7	99.6	31.4	75.5	112.9	47.3	91.3	123.0
	kW	16.77	16.71	16.37	17.10	16.78	16.54	17.20	16.95	16.71

48HC*E17 (15 TONS) – UNIT WITH HUMIDI-MIZER IN HOT GAS REHEAT MODE										
Temp (F) Air Ent Condenser (Edb)		AIR ENTERING EVAPORATOR (F)								
		75 Dry Bulb			75 Dry Bulb			75 Dry Bulb		
		62.5 Wet Bulb			64 Wet Bulb			65.3 Wet Bulb		
		(50% Relative)			(56% Relative)			(60% Relative)		
		Air Entering Evaporator – Cfm								
4,500	6,000	7,500	4,500	6,000	7,500	4,500	6,000	7,500		
80	TC	64.50	71.00	73.30	68.40	74.50	77.30	71.20	79.70	80.60
	SHC	12.60	24.90	36.80	6.80	13.70	23.90	-0.80	5.50	13.80
	kW	10.10	10.26	10.42	10.18	10.40	10.56	10.33	10.47	10.67
75	TC	66.60	73.10	75.60	70.50	76.60	79.50	73.20	80.80	82.90
	SHC	14.30	26.70	38.50	8.10	14.90	25.70	0.70	7.00	15.00
	kW	10.05	10.22	10.36	10.14	10.36	10.52	10.28	10.43	10.62
70	TC	68.70	75.10	77.40	72.50	78.60	81.40	75.20	82.80	84.90
	SHC	15.40	27.80	40.00	9.50	16.20	26.80	2.10	8.40	16.30
	kW	10.00	10.18	10.33	10.10	10.31	10.47	10.23	10.40	10.58
60	TC	72.80	79.30	81.60	76.70	82.80	85.70	79.40	86.90	88.80
	SHC	19.00	31.10	43.20	12.70	19.90	30.10	5.30	11.60	20.00
	kW	9.92	10.09	10.24	10.01	10.22	10.37	10.14	10.31	10.49
50	TC	76.80	83.40	85.70	80.80	86.90	89.70	83.50	90.90	92.80
	SHC	21.70	34.20	46.20	15.80	22.70	33.20	8.40	14.70	22.80
	kW	9.83	10.00	10.15	9.92	10.13	10.29	10.05	10.21	10.39
40	TC	80.90	87.30	89.60	84.90	90.80	93.60	87.40	94.80	96.70
	SHC	24.90	37.10	49.30	19.00	26.00	36.10	11.60	17.90	26.20
	kW	9.74	9.91	10.06	9.83	10.04	10.20	9.96	10.12	10.30

LEGEND

- Edb** – Entering Dry–Bulb
- Ewb** – Entering Wet–Bulb
- kW** – Compressor Motor Power Input
- ldb** – Leaving Dry–Bulb
- lwb** – Leaving Wet–Bulb
- SHC** – Sensible Heat Capacity (1000 Btuh) Gross
- TC** – Total Capacity (1000 Btuh) Gross

NOTES:

1. Direct interpolation is permissible. Do not extrapolate.
2. The following formulas may be used:

$$t_{ldb} = t_{edb} - \frac{\text{sensible capacity (Btuh)}}{1.10 \times \text{cfm}}$$

t_{lwb} = Wet–bulb temperature corresponding to enthalpy of air leaving evaporator coil (h_{lwb})

$$h_{lwb} = h_{ewb} - \frac{\text{total capacity (Btuh)}}{4.5 \times \text{cfm}}$$

Where: h_{ewb} = Enthalpy of air entering evaporator coil

Table 10 – COOLING CAPACITIES

2-STAGE COOLING

17.5 TONS

48HC*D20			AMBIENT TEMPERATURE (F)															
			85			95			105			115			125			
			EAT (db)			EAT (db)			EAT (db)			EAT (db)			EAT (db)			
			75	80	85	75	80	85	75	80	85	75	80	85	75	80	85	
5250 CFM	EAT (wb)	58	TC	185.1	185.1	209.2	178.7	178.7	201.9	171.8	171.8	194.1	164.5	164.5	185.8	156.7	156.7	177.0
			SHC	161.1	185.1	209.2	155.4	178.7	201.9	149.4	171.8	194.1	143.1	164.5	185.8	136.3	156.7	177.0
		62	TC	193.8	193.8	199.5	185.6	185.6	195.4	176.9	176.9	191.1	167.7	167.7	186.4	158.2	158.2	181.1
			SHC	145.6	172.6	199.5	141.7	168.6	195.4	137.6	164.4	191.1	133.2	159.8	186.4	128.3	154.7	181.1
		67	TC	212.2	212.2	212.2	203.3	203.3	203.3	193.8	193.8	193.8	183.8	183.8	183.8	173.1	173.1	173.1
			SHC	119.0	146.0	173.1	115.3	142.3	169.4	111.4	138.4	165.4	107.3	134.3	161.3	103.0	130.0	157.0
		72	TC	232.3	232.3	232.3	222.7	222.7	222.7	212.4	212.4	212.4	201.6	201.6	201.6	190.1	190.1	190.1
			SHC	91.5	118.8	146.2	87.9	115.2	142.5	84.1	111.4	138.7	80.2	107.4	134.6	76.0	103.2	130.4
		76	TC	-	249.5	249.5	-	239.2	239.2	-	228.2	228.2	-	216.6	216.6	-	204.3	204.3
			SHC	-	96.7	125.3	-	93.2	121.7	-	89.5	117.9	-	85.6	113.8	-	81.5	109.5
6125 CFM	EAT (wb)	58	TC	194.7	194.7	220.0	187.8	187.8	212.2	180.4	180.4	203.8	172.5	172.5	194.9	164.1	164.1	185.5
			SHC	169.4	194.7	220.0	163.3	187.8	212.2	156.9	180.4	203.8	150.1	172.5	194.9	142.8	164.1	185.5
		62	TC	199.6	199.6	218.0	191.1	191.1	213.5	182.1	182.1	208.4	173.0	173.0	201.2	164.3	164.3	192.8
			SHC	156.5	187.2	218.0	152.3	182.9	213.5	147.7	178.0	208.4	141.8	171.5	201.2	135.8	164.3	192.8
		67	TC	218.0	218.0	218.0	208.7	208.7	208.7	198.7	198.7	198.7	188.2	188.2	188.2	177.1	177.1	177.1
			SHC	126.2	157.4	188.6	122.4	153.6	184.7	118.4	149.6	180.7	114.3	145.4	176.5	109.9	141.0	172.1
		72	TC	238.5	238.5	238.5	228.4	228.4	228.4	217.7	217.7	217.7	206.3	206.3	206.3	194.3	194.3	194.3
			SHC	94.7	126.1	157.5	91.0	122.4	153.8	87.2	118.5	149.8	83.1	114.4	145.7	78.9	110.1	141.4
		76	TC	-	255.9	255.9	-	245.1	245.1	-	233.6	233.6	-	221.4	221.4	-	208.5	208.5
			SHC	-	100.7	133.3	-	97.1	129.6	-	93.3	125.6	-	89.3	121.5	-	85.1	117.1
7000 CFM	EAT (wb)	58	TC	202.7	202.7	229.1	195.4	195.4	220.8	187.5	187.5	211.9	179.2	179.2	202.5	170.3	170.3	192.4
			SHC	176.4	202.7	229.1	170.0	195.4	220.8	163.1	187.5	211.9	155.9	179.2	202.5	148.1	170.3	192.4
		62	TC	204.6	204.6	234.4	196.0	196.0	228.0	187.7	187.7	220.3	179.3	179.3	210.5	170.4	170.4	200.0
			SHC	166.0	200.2	234.4	160.8	194.4	228.0	155.1	187.7	220.3	148.2	179.3	210.5	140.8	170.4	200.0
		67	TC	222.5	222.5	222.5	212.8	212.8	212.8	202.4	202.4	202.4	191.5	191.5	191.5	180.0	180.0	186.4
			SHC	133.0	168.2	203.4	129.2	164.3	199.5	125.1	160.3	195.4	120.9	156.0	191.0	116.4	151.4	186.4
		72	TC	243.3	243.3	243.3	232.7	232.7	232.7	221.6	221.6	221.6	209.9	209.9	209.9	197.4	197.4	197.4
			SHC	97.5	132.9	168.3	93.8	129.2	164.5	89.9	125.2	160.5	85.8	121.1	156.3	81.6	116.7	151.9
		76	TC	-	260.8	260.8	-	249.6	249.6	-	237.7	237.7	-	225.1	225.1	-	211.7	211.7
			SHC	-	104.4	140.8	-	100.7	137.0	-	96.9	133.0	-	92.8	128.8	-	88.5	124.4
7875 CFM	EAT (wb)	58	TC	209.6	209.6	236.8	201.8	201.8	228.1	193.6	193.6	218.8	184.8	184.8	208.9	175.5	175.5	198.3
			SHC	182.3	209.6	236.8	175.6	201.8	228.1	168.4	193.6	218.8	160.8	184.8	208.9	152.7	175.5	198.3
		62	TC	209.8	209.8	246.2	202.0	202.0	237.1	193.8	193.8	227.4	185.0	185.0	217.1	175.6	175.6	206.1
			SHC	173.4	209.8	246.2	167.0	202.0	237.1	160.1	193.8	227.4	152.9	185.0	217.1	145.1	175.6	206.1
		67	TC	226.1	226.1	226.1	216.0	216.0	216.0	205.4	205.4	209.4	194.2	194.2	204.8	182.4	182.4	199.9
			SHC	139.6	178.6	217.7	135.6	174.7	213.7	131.5	170.5	209.4	127.1	166.0	204.8	122.5	161.2	199.9
		72	TC	247.0	247.0	247.0	236.2	236.2	236.2	224.7	224.7	224.7	212.7	212.7	212.7	199.9	199.9	199.9
			SHC	100.2	139.5	178.8	96.5	135.7	174.9	92.5	131.7	170.9	88.4	127.5	166.6	84.1	123.1	162.1
		76	TC	-	264.7	264.7	-	253.1	253.1	-	240.9	240.9	-	227.9	227.9	-	-	-
			SHC	-	107.9	148.1	-	104.2	144.3	-	100.2	140.2	-	96.1	135.9	-	-	-
8750 CFM	EAT (wb)	58	TC	215.4	215.4	243.4	207.3	207.3	234.3	198.7	198.7	224.6	189.6	189.6	214.2	179.9	179.9	203.2
			SHC	187.4	215.4	243.4	180.3	207.3	234.3	172.9	198.7	224.6	164.9	189.6	214.2	156.5	179.9	203.2
		62	TC	215.5	215.5	253.0	207.5	207.5	243.5	198.9	198.9	233.4	189.7	189.7	222.7	180.0	180.0	211.2
			SHC	178.1	215.5	253.0	171.5	207.5	243.5	164.4	198.9	233.4	156.8	189.7	222.7	148.8	180.0	211.2
		67	TC	228.9	228.9	231.5	218.7	218.7	227.3	207.8	207.8	222.8	196.4	196.4	217.9	184.5	184.5	212.6
			SHC	145.8	188.6	231.5	141.8	184.5	227.3	137.5	180.1	222.8	133.0	175.5	217.9	128.2	170.4	212.6
		72	TC	250.1	250.1	250.1	239.0	239.0	239.0	227.3	227.3	227.3	214.9	214.9	214.9	201.8	201.8	201.8
			SHC	102.8	145.8	188.9	99.0	142.0	185.0	95.0	137.9	180.9	90.8	133.7	176.5	86.4	129.2	172.0
		76	TC	-	267.8	267.8	-	256.0	256.0	-	243.5	243.5	-	230.2	230.2	-	-	-
			SHC	-	111.2	155.2	-	107.4	151.3	-	103.5	147.1	-	99.3	142.8	-	-	-

NOTE: See Minimum–Maximum Airflow Ratings in Table 5. Do not operate outside these limits.

LEGEND:

- Do not operate
- Cfm - Cubic feet per minute (supply air)
- EAT (db) - Entering Air Temperature (dry bulb)
- EAT (wb) - Entering Air Temperature (wet bulb)
- SHC - Sensible Heat Capacity (1000 Btuh) Gross
- TC - Total Capacity (1000 Btuh) Gross

48HC*E20 (17.5 TONS) – UNIT WITH HUMIDI-MIZER IN SUBCOOLING MODE										
Temp (F) Air Ent Condenser (Edb)		AIR ENTERING EVAPORATOR – CFM								
		5,250			7,000			8,750		
		Air Entering Evaporator – Ewb (F)								
		72	67	62	72	67	62	72	67	62
75	TC	232.0	211.3	190.6	242.4	221.0	199.7	250.7	228.9	207.0
	SHC	110.9	133.7	156.4	127.6	150.3	173.0	141.1	163.7	186.4
	kW	12.45	12.16	11.81	12.74	12.41	12.02	12.93	12.51	12.18
85	TC	215.9	195.7	175.5	226.0	205.2	184.4	234.2	212.8	191.5
	SHC	90.6	118.8	147.0	108.4	136.6	164.9	122.7	151.0	179.2
	kW	13.48	13.20	12.88	13.77	13.47	13.07	13.96	13.58	13.23
95	TC	199.7	180.0	160.3	209.7	189.4	169.1	217.6	196.8	176.1
	SHC	70.3	104.0	137.7	89.2	123.0	156.7	104.4	138.2	172.1
	kW	14.60	14.25	13.94	14.89	14.51	14.15	15.08	14.63	14.31
105	TC	183.6	164.5	145.2	193.3	173.5	153.8	201.0	180.8	160.6
	SHC	50.0	89.1	128.3	70.0	109.3	148.6	86.0	125.5	158.6
	kW	15.64	15.36	15.01	15.93	15.60	15.21	16.12	15.72	15.37
115	TC	167.5	148.8	130.1	176.9	157.7	138.5	184.5	164.8	145.1
	SHC	29.7	74.3	118.9	50.7	95.6	138.1	67.7	112.7	145.1
	kW	16.70	16.38	15.82	16.98	16.63	16.03	17.17	16.75	16.19
125	TC	151.4	133.2	115.0	160.6	141.9	123.1	167.9	148.8	129.7
	SHC	9.4	59.5	109.6	31.5	81.9	123.0	49.3	100.0	129.7
	kW	17.71	17.39	17.09	18.01	17.65	17.30	18.20	17.76	17.46

48HC*E020 (17.5 TONS) – UNIT WITH HUMIDI-MIZER IN HOT GAS REHEAT MODE										
Temp (F) Air Ent Condenser (Edb)		AIR ENTERING EVAPORATOR (F)								
		75 Dry Bulb			75 Dry Bulb			75 Dry Bulb		
		62.5 Wet Bulb			64 Wet Bulb			65.3 Wet Bulb		
		(50% Relative)			(56% Relative)			(60% Relative)		
		Air Entering Evaporator – Cfm								
		5,250	7,000	8,750	5,250	7,000	8,750	5,250	7,000	8,750
80	TC	67.80	71.30	74.10	70.50	74.80	79.80	73.30	78.20	82.40
	SHC	9.00	26.50	41.70	2.20	13.20	26.90	-5.20	2.90	13.80
	kW	11.65	11.75	11.87	11.82	11.90	11.98	11.93	12.10	12.19
75	TC	72.50	76.00	78.80	75.00	79.20	84.30	78.00	83.00	86.90
	SHC	13.40	30.90	46.10	6.50	18.00	31.30	-2.10	7.20	17.90
	kW	11.44	11.54	11.66	11.61	11.68	11.75	11.70	11.86	11.95
70	TC	77.10	80.60	83.40	79.50	83.90	88.90	82.40	87.30	91.10
	SHC	17.60	34.70	49.90	10.80	22.20	35.10	3.20	11.50	22.20
	kW	11.22	11.33	11.45	11.40	11.46	11.54	11.49	11.64	11.75
60	TC	86.30	89.90	92.70	88.80	93.20	98.20	91.70	96.60	100.50
	SHC	26.20	43.20	58.40	19.40	30.80	43.60	11.60	20.10	30.70
	kW	10.76	10.86	10.98	10.93	11.00	11.07	11.03	11.18	11.28
50	TC	95.50	99.10	101.90	98.00	102.40	107.40	101.00	106.00	109.80
	SHC	34.80	51.80	67.00	28.00	39.40	52.20	20.10	28.70	39.40
	kW	10.33	10.43	10.55	10.50	10.52	10.63	10.59	10.74	10.85
40	TC	104.80	108.40	111.20	107.30	111.70	116.60	110.30	115.30	119.10
	SHC	43.40	60.40	75.60	36.60	48.00	60.80	28.80	37.30	47.90
	kW	9.87	9.97	10.09	10.04	10.11	10.18	10.14	10.28	10.40

LEGEND

- Edb** – Entering Dry–Bulb
- Ewb** – Entering Wet–Bulb
- kW** – Compressor Motor Power Input
- ldb** – Leaving Dry–Bulb
- lwb** – Leaving Wet–Bulb
- SHC** – Sensible Heat Capacity (1000 Btuh) Gross
- TC** – Total Capacity (1000 Btuh) Gross

NOTES:

1. Direct interpolation is permissible. Do not extrapolate.
2. The following formulas may be used:

$$t_{ldb} = t_{edb} - \frac{\text{sensible capacity (Btuh)}}{1.10 \times \text{cfm}}$$

t_{lwb} = Wet–bulb temperature corresponding to enthalpy of air leaving evaporator coil (h_{lwb})

$$h_{lwb} = h_{ewb} - \frac{\text{total capacity (Btuh)}}{4.5 \times \text{cfm}}$$

Where: h_{ewb} = Enthalpy of air entering evaporator coil

Table 12 – COOLING CAPACITIES

2-STAGE COOLING

20 TONS

48HC*D24			AMBIENT TEMPERATURE (F)															
			85			95			105			115			125			
			EAT (db)			EAT (db)			EAT (db)			EAT (db)			EAT (db)			
			75	80	85	75	80	85	75	80	85	75	80	85	75	80	85	
6000 CFM	EAT (wb)	58	TC	214.4	214.4	242.5	207.0	207.0	234.2	199.0	199.0	225.1	190.2	190.2	215.2	180.6	180.6	204.3
			SHC	186.3	214.4	242.5	179.9	207.0	234.2	173.0	199.0	225.1	165.3	190.2	215.2	157.0	180.6	204.3
		62	TC	226.8	226.8	227.7	217.3	217.3	223.0	206.9	206.9	218.0	195.8	195.8	212.5	183.7	183.7	206.4
			SHC	167.0	197.3	227.7	162.4	192.7	223.0	157.6	187.8	218.0	152.3	182.4	212.5	146.6	176.5	206.4
		67	TC	248.4	248.4	248.4	237.9	237.9	237.9	226.6	226.6	226.6	214.3	214.3	214.3	201.0	201.0	201.0
			SHC	136.5	167.1	197.6	132.2	162.7	193.2	127.5	158.0	188.4	122.5	152.9	183.4	117.2	147.6	178.0
		72	TC	271.9	271.9	271.9	260.3	260.3	260.3	247.9	247.9	247.9	234.5	234.5	234.5	220.1	220.1	220.1
			SHC	105.1	136.0	167.0	100.8	131.7	162.5	96.3	127.1	157.9	91.4	122.1	152.9	86.3	116.9	147.6
		76	TC	-	291.7	291.7	-	279.2	279.2	-	265.7	265.7	-	251.3	251.3	-	235.8	235.8
			SHC	-	110.7	143.7	-	106.5	139.5	-	102.0	134.7	-	97.2	129.7	-	92.1	124.3
7000 CFM	EAT (wb)	58	TC	225.8	225.8	255.3	217.8	217.8	246.3	209.1	209.1	236.5	199.6	199.6	225.7	189.2	189.2	214.0
			SHC	196.2	225.8	255.3	189.3	217.8	246.3	181.7	209.1	236.5	173.4	199.6	225.7	164.4	189.2	214.0
		62	TC	233.9	233.9	248.8	223.8	223.8	243.8	213.1	213.1	238.2	201.4	201.4	231.8	190.0	190.0	221.5
			SHC	179.4	214.1	248.8	174.6	209.2	243.8	169.4	203.8	238.2	163.7	197.8	231.8	155.9	188.7	221.5
		67	TC	255.7	255.7	255.7	244.6	244.6	244.6	232.6	232.6	232.6	219.6	219.6	219.6	205.7	205.7	205.7
			SHC	144.7	179.7	214.8	140.2	175.2	210.2	135.4	170.4	205.4	130.3	165.2	200.2	124.9	159.8	194.7
		72	TC	279.4	279.4	279.4	267.3	267.3	267.3	254.1	254.1	254.1	240.1	240.1	240.1	224.9	224.9	224.9
			SHC	108.7	144.1	179.6	104.3	139.7	175.1	99.6	135.0	170.3	94.7	129.9	165.1	89.5	124.6	159.7
		76	TC	-	299.4	299.4	-	286.2	286.2	-	272.1	272.1	-	256.9	256.9	-	240.7	240.7
			SHC	-	115.3	152.9	-	110.9	148.2	-	106.3	143.3	-	101.3	138.0	-	96.1	132.6
8000 CFM	EAT (wb)	58	TC	235.3	235.3	266.2	226.8	226.8	256.5	217.5	217.5	246.0	207.4	207.4	234.5	196.3	196.3	222.0
			SHC	204.5	235.3	266.2	197.1	226.8	256.5	189.0	217.5	246.0	180.2	207.4	234.5	170.6	196.3	222.0
		62	TC	239.7	239.7	268.1	229.4	229.4	262.0	219.0	219.0	253.3	208.3	208.3	241.9	196.7	196.7	231.0
			SHC	190.7	229.4	268.1	185.4	223.7	262.0	178.6	215.9	253.3	170.4	206.2	241.9	162.3	196.7	231.0
		67	TC	261.3	261.3	261.3	249.6	249.6	249.6	237.1	237.1	237.1	223.6	223.6	223.6	209.2	209.2	210.6
			SHC	152.3	191.8	231.2	147.7	187.1	226.6	142.9	182.2	221.6	137.7	177.0	216.3	132.2	171.4	210.6
		72	TC	285.3	285.3	285.3	272.5	272.5	272.5	258.9	258.9	258.9	244.2	244.2	244.2	228.6	228.6	228.6
			SHC	111.9	151.7	191.5	107.5	147.2	186.9	102.7	142.4	182.0	97.7	137.2	176.7	92.4	131.8	171.2
		76	TC	-	305.4	305.4	-	291.6	291.6	-	276.8	276.8	-	261.2	261.2	-	244.4	244.4
			SHC	-	119.4	161.0	-	114.9	156.2	-	110.1	151.2	-	105.1	146.0	-	99.8	140.4
9000 CFM	EAT (wb)	58	TC	243.5	243.5	275.4	234.5	234.5	265.2	224.6	224.6	254.0	213.9	213.9	241.9	202.3	202.3	228.8
			SHC	211.6	243.5	275.4	203.8	234.5	265.2	195.2	224.6	254.0	185.9	213.9	241.9	175.8	202.3	228.8
		62	TC	245.4	245.4	282.9	235.4	235.4	274.6	225.0	225.0	264.3	214.4	214.4	251.7	202.5	202.5	237.8
			SHC	199.7	241.3	282.9	193.2	233.9	274.6	185.6	224.9	264.3	176.8	214.3	251.7	167.1	202.5	237.8
		67	TC	265.6	265.6	265.6	253.6	253.6	253.6	240.7	240.7	240.7	226.8	226.8	231.8	212.0	212.0	225.8
			SHC	159.6	203.3	247.1	154.9	198.6	242.3	150.0	193.6	237.3	144.7	188.3	231.8	139.0	182.4	225.8
		72	TC	289.9	289.9	289.9	276.7	276.7	276.7	262.6	262.6	262.6	247.5	247.5	247.5	231.4	231.4	231.4
			SHC	114.9	159.0	203.0	110.4	154.4	198.3	105.6	149.5	193.3	100.5	144.2	188.0	95.2	138.7	182.3
		76	TC	-	310.1	310.1	-	295.8	295.8	-	280.6	280.6	-	264.4	264.4	-	247.3	247.3
			SHC	-	123.2	168.9	-	118.6	164.1	-	113.8	159.0	-	108.7	153.6	-	103.4	147.9
10,000 CFM	EAT (wb)	58	TC	250.4	250.4	283.2	240.9	240.9	272.5	230.7	230.7	260.9	219.5	219.5	248.2	207.3	207.3	234.5
			SHC	217.7	250.4	283.2	209.4	240.9	272.5	200.5	230.7	260.9	190.7	219.5	248.2	180.2	207.3	234.5
		62	TC	250.8	250.8	294.6	241.1	241.1	283.3	231.1	231.1	271.4	219.6	219.6	258.0	207.5	207.5	243.7
			SHC	207.0	250.8	294.6	199.0	241.1	283.3	190.7	231.1	271.4	181.2	219.6	258.0	171.2	207.5	243.7
		67	TC	269.2	269.2	269.2	256.8	256.8	257.6	243.5	243.5	252.3	229.4	229.4	246.4	214.3	214.3	240.0
			SHC	166.6	214.5	262.5	161.9	209.7	257.6	156.8	204.5	252.3	151.3	198.9	246.4	145.5	192.8	240.0
		72	TC	293.7	293.7	293.7	280.1	280.1	280.1	265.6	265.6	265.6	250.2	250.2	250.2	233.7	233.7	233.7
			SHC	117.8	166.0	214.2	113.2	161.3	209.3	108.3	156.3	204.3	103.2	151.0	198.8	97.8	145.4	193.1
		76	TC	-	313.9	313.9	-	299.3	299.3	-	283.7	283.7	-	267.1	267.1	-	249.6	249.6
			SHC	-	126.8	176.5	-	122.2	171.6	-	117.3	166.5	-	112.1	161.0	-	106.7	155.1

NOTE: See Minimum–Maximum Airflow Ratings in Table 5. Do not operate outside these limits.

LEGEND:

- Do not operate
- Cfm - Cubic feet per minute (supply air)
- EAT (db) - Entering Air Temperature (dry bulb)
- EAT (wb) - Entering Air Temperature (wet bulb)
- SHC - Sensible Heat Capacity (1000 Btuh) Gross
- TC - Total Capacity (1000 Btuh) Gross

Table 13 – COOLING CAPACITIES

2-STAGE COOLING

20 TONS (cont.)

48HC*E24 (20 TONS) – UNIT WITH HUMIDI-MIZER IN SUBCOOLING MODE										
Temp (F) Air Ent Condenser (Edb)		AIR ENTERING EVAPORATOR – CFM								
		6,000			8,000			10,000		
		Air Entering Evaporator – Ewb (F)								
		72	67	62	72	67	62	72	67	62
75	TC	281.6	256.5	231.3	293.1	267.0	240.9	302.3	275.4	248.6
	SHC	114.7	141.0	167.4	140.6	166.6	192.6	161.6	187.3	212.9
	kW	13.52	13.25	12.95	13.82	13.46	13.21	13.97	13.60	13.31
85	TC	261.3	236.9	212.4	272.1	247.7	221.3	280.7	254.6	228.5
	SHC	90.9	123.5	156.1	118.8	151.1	183.3	141.4	173.4	205.4
	kW	14.95	14.68	14.48	15.25	14.89	14.64	15.40	15.03	14.74
95	TC	241.1	217.2	193.4	251.1	226.4	201.7	259.2	233.8	208.4
	SHC	67.2	106.0	144.8	97.1	120.1	174.1	121.2	159.5	197.8
	kW	16.52	16.25	15.95	16.82	16.46	16.21	16.97	16.60	16.31
105	TC	220.8	197.5	174.4	230.2	206.2	182.2	237.7	213.0	188.4
	SHC	43.4	88.4	133.5	75.3	120.1	164.9	101.0	145.7	178.9
	kW	18.09	17.82	17.52	18.39	18.03	17.78	18.54	18.17	17.88
115	TC	200.5	178.0	155.5	209.2	185.9	162.6	216.2	192.2	168.7
	SHC	19.7	70.9	122.2	53.5	104.6	155.7	80.9	131.8	161.2
	kW	19.65	19.38	19.08	19.95	19.59	19.34	20.10	19.73	19.44
125	TC	180.2	158.4	136.5	188.2	165.6	143.0	194.7	171.4	148.2
	SHC	-4.1	53.4	110.8	31.7	89.1	142.2	60.7	118.0	145.1
	kW	20.59	20.32	20.02	20.89	20.53	20.28	21.04	20.67	20.38

48HC*E24 (20 TONS) – UNIT WITH HUMIDI-MIZER IN HOT GAS REHEAT MODE										
Temp (F) Air Ent Condenser (Edb)		AIR ENTERING EVAPORATOR (F)								
		75 Dry Bulb			75 Dry Bulb			75 Dry Bulb		
		62.5 Wet Bulb			64 Wet Bulb			65.3 Wet Bulb		
		(50% Relative)			(56% Relative)			(60% Relative)		
		Air Entering Evaporator – Cfm								
6,000	8,000	10,000	6,000	8,000	10,000	6,000	8,000	10,000		
80	TC	115.20	123.30	130.60	120.40	129.30	138.20	122.80	135.00	143.70
	SHC	40.80	58.30	76.10	32.30	45.50	60.40	20.10	34.30	48.00
	kW	13.24	13.32	13.39	13.43	13.57	13.65	13.49	13.68	13.74
75	TC	119.80	128.60	135.90	125.50	135.30	143.20	128.00	139.50	148.40
	SHC	45.60	62.80	82.10	37.00	49.80	65.20	24.30	38.70	52.60
	kW	13.05	13.10	13.17	13.21	13.35	13.43	13.27	13.46	13.52
70	TC	122.50	133.10	140.20	129.80	140.70	147.60	132.40	144.40	153.20
	SHC	49.80	76.00	86.10	41.10	54.30	69.20	28.80	41.40	56.80
	kW	12.80	12.87	12.94	12.98	13.12	13.20	13.04	13.23	13.29
60	TC	133.80	142.50	149.60	139.30	150.40	157.40	141.50	154.20	163.00
	SHC	58.60	76.00	95.00	50.20	63.50	78.10	37.80	52.10	65.90
	kW	12.34	12.42	12.49	12.53	12.67	12.75	12.59	12.78	12.84
50	TC	143.50	151.80	159.30	149.00	160.00	167.00	151.30	163.60	172.50
	SHC	67.70	84.80	103.80	59.10	72.40	87.00	46.70	61.00	74.90
	kW	11.88	11.95	12.03	12.07	12.21	12.29	12.13	12.32	12.38
40	TC	153.20	161.30	168.70	158.60	169.20	176.60	160.80	173.10	182.00
	SHC	76.50	93.60	111.60	68.00	81.50	95.80	55.80	69.80	84.00
	kW	11.42	11.49	11.56	11.60	11.74	11.82	11.66	11.85	11.91

LEGEND

- Edb – Entering Dry–Bulb
- Ewb – Entering Wet–Bulb
- kW – Compressor Motor Power Input
- ldb – Leaving Dry–Bulb
- lwb – Leaving Wet–Bulb
- SHC – Sensible Heat Capacity (1000 Btuh) Gross
- TC – Total Capacity (1000 Btuh) Gross

NOTES:

1. Direct interpolation is permissible. Do not extrapolate.
2. The following formulas may be used:

$$t_{ldb} = t_{edb} - \frac{\text{sensible capacity (Btuh)}}{1.10 \times \text{cfm}}$$

t_{lwb} = Wet–bulb temperature corresponding to enthalpy of air leaving evaporator coil (h_{lwb})

$$h_{lwb} = h_{ewb} - \frac{\text{total capacity (Btuh)}}{4.5 \times \text{cfm}}$$

Where: h_{ewb} = Enthalpy of air entering evaporator coil

Table 14 – COOLING CAPACITIES

2-STAGE COOLING

25 TONS

48HC*D28			AMBIENT TEMPERATURE (F)															
			85			95			105			115			125			
			EAT (db)			EAT (db)			EAT (db)			EAT (db)			EAT (db)			
			75	80	85	75	80	85	75	80	85	75	80	85	75	80	85	
7,500 CFM	EAT (wb)	58	TC	264.4	264.4	298.9	254.6	254.6	287.9	244.1	244.1	276.0	232.7	232.7	263.1	220.3	220.3	249.1
			SHC	229.9	264.4	298.9	221.4	254.6	287.9	212.2	244.1	276.0	202.3	232.7	263.1	191.5	220.3	249.1
		62	TC	278.7	278.7	282.4	266.3	266.3	276.4	252.8	252.8	269.8	238.5	238.5	262.4	223.9	223.9	251.3
			SHC	206.8	244.6	282.4	200.9	238.7	276.4	194.6	232.2	269.8	187.7	225.0	262.4	178.7	215.0	251.3
		67	TC	305.3	305.3	305.3	291.9	291.9	291.9	277.3	277.3	277.3	261.5	261.5	261.5	244.5	244.5	244.5
			SHC	169.0	207.0	245.0	163.4	201.4	239.4	157.4	195.3	233.3	151.0	188.9	226.8	144.2	182.1	219.9
		72	TC	334.0	334.0	334.0	319.4	319.4	319.4	303.6	303.6	303.6	286.5	286.5	286.5	268.1	268.1	268.1
			SHC	129.9	168.5	207.1	124.5	163.0	201.5	118.7	157.1	195.5	112.5	150.8	189.2	106.0	144.2	182.3
		76	TC	-	358.2	358.2	-	342.4	342.4	-	325.4	325.4	-	307.1	307.1	-	287.4	287.4
			SHC	-	137.0	178.2	-	131.7	172.9	-	126.0	166.9	-	119.9	160.4	-	113.4	153.4
8,750 CFM	EAT (wb)	58	TC	278.2	278.2	314.5	267.8	267.8	302.8	256.5	256.5	289.9	244.2	244.2	276.1	230.8	230.8	261.0
			SHC	241.9	278.2	314.5	232.8	267.8	302.8	223.0	256.5	289.9	212.3	244.2	276.1	200.7	230.8	261.0
		62	TC	287.2	287.2	308.3	274.3	274.3	301.5	260.8	260.8	291.7	247.0	247.0	280.9	232.0	232.0	269.1
			SHC	222.1	265.2	308.3	215.7	258.6	301.5	207.7	249.7	291.7	199.0	240.0	280.9	189.7	229.4	269.1
		67	TC	314.0	314.0	314.0	299.8	299.8	299.8	284.4	284.4	284.4	267.8	267.8	267.8	250.0	250.0	250.0
			SHC	179.1	222.7	266.4	173.3	216.9	260.6	167.2	210.8	254.3	160.7	204.2	247.7	153.7	197.2	240.6
		72	TC	343.0	343.0	343.0	327.7	327.7	327.7	311.1	311.1	311.1	293.1	293.1	293.1	273.8	273.8	273.8
			SHC	134.3	178.5	222.6	128.8	172.9	216.9	122.9	166.9	210.8	116.6	160.4	204.3	109.9	153.6	197.3
		76	TC	-	367.3	367.3	-	350.8	350.8	-	333.0	333.0	-	313.8	313.8	-	293.2	293.2
			SHC	-	142.6	189.4	-	137.1	183.5	-	131.2	177.3	-	125.0	170.7	-	118.4	163.7
10,000 CFM	EAT (wb)	58	TC	289.7	289.7	327.5	278.7	278.7	315.0	266.6	266.6	301.4	253.6	253.6	286.7	239.4	239.4	270.7
			SHC	251.9	289.7	327.5	242.3	278.7	315.0	231.8	266.6	301.4	220.5	253.6	286.7	208.2	239.4	270.7
		62	TC	294.6	294.6	329.6	282.2	282.2	319.7	268.7	268.7	309.1	254.1	254.1	298.4	239.7	239.7	281.4
			SHC	234.7	282.1	329.6	226.8	273.3	319.7	218.4	263.7	309.1	209.7	254.1	298.4	197.9	239.7	281.4
		67	TC	320.6	320.6	320.6	305.9	305.9	305.9	289.9	289.9	289.9	272.7	272.7	272.7	254.3	254.3	260.3
			SHC	188.6	237.7	286.8	182.7	231.8	280.9	176.5	225.5	274.5	169.8	218.8	267.7	162.8	211.5	260.3
		72	TC	350.0	350.0	350.0	334.0	334.0	334.0	316.8	316.8	316.8	298.2	298.2	298.2	278.3	278.3	278.3
			SHC	138.4	187.9	237.5	132.8	182.2	231.7	126.8	176.1	225.5	120.4	169.6	218.8	113.6	162.6	211.7
		76	TC	-	374.4	374.4	-	357.3	357.3	-	338.7	338.7	-	318.9	318.9	-	297.5	297.5
			SHC	-	147.7	199.5	-	142.1	193.7	-	136.1	187.4	-	129.7	180.6	-	123.0	173.5
11,250 CFM	EAT (wb)	58	TC	299.4	299.4	338.4	287.8	287.8	325.4	275.2	275.2	311.1	261.4	261.4	295.6	246.6	246.6	278.8
			SHC	260.3	299.4	338.4	250.2	287.8	325.4	239.2	275.2	311.1	227.3	261.4	295.6	214.4	246.6	278.8
		62	TC	302.2	302.2	346.0	289.3	289.3	335.7	275.5	275.5	323.5	262.1	262.1	307.7	246.8	246.8	289.8
			SHC	244.8	295.4	346.0	236.7	286.2	335.7	227.5	275.5	323.5	216.4	262.1	307.7	203.8	246.8	289.8
		67	TC	325.9	325.9	325.9	310.7	310.7	310.7	294.2	294.2	294.2	276.6	276.6	286.7	257.7	257.7	278.9
			SHC	197.6	252.1	306.5	191.7	246.1	300.4	185.3	239.6	293.9	178.5	232.6	286.7	171.2	225.1	278.9
		72	TC	355.5	355.5	355.5	339.1	339.1	339.1	321.3	321.3	321.3	302.2	302.2	302.2	281.8	281.8	281.8
			SHC	142.1	197.0	251.8	136.4	191.2	245.9	130.4	185.0	239.6	123.9	178.3	232.8	117.1	171.3	225.5
		76	TC	-	380.0	380.0	-	362.4	362.4	-	343.3	343.3	-	322.8	322.8	-	300.9	300.9
			SHC	-	152.4	209.4	-	146.8	203.4	-	140.7	197.0	-	134.2	190.2	-	127.3	182.8
12,500 CFM	EAT (wb)	58	TC	307.7	307.7	347.9	295.7	295.7	334.2	282.5	282.5	319.3	268.2	268.2	303.2	252.7	252.7	285.7
			SHC	267.6	307.7	347.9	257.1	295.7	334.2	245.6	282.5	319.3	233.2	268.2	303.2	219.7	252.7	285.7
		62	TC	308.4	308.4	362.2	295.9	295.9	347.4	283.1	283.1	332.4	268.4	268.4	315.2	252.8	252.8	296.9
			SHC	254.6	308.4	362.2	244.4	295.9	347.4	233.8	283.1	332.4	221.7	268.4	315.2	208.8	252.8	296.9
		67	TC	330.2	330.2	330.2	314.6	314.6	319.2	297.8	297.8	312.3	279.8	279.8	304.7	260.6	260.6	295.9
			SHC	206.3	265.9	325.5	200.3	259.7	319.2	193.8	253.1	312.3	186.7	245.7	304.7	179.0	237.4	295.9
		72	TC	360.1	360.1	360.1	343.2	343.2	343.2	325.0	325.0	325.0	305.4	305.4	305.4	284.6	284.6	284.6
			SHC	145.7	205.7	265.7	139.9	199.8	259.7	133.8	193.5	253.3	127.3	186.8	246.3	120.4	179.7	238.9
		76	TC	-	384.6	384.6	-	366.5	366.5	-	346.9	346.9	-	325.9	325.9	-	303.5	303.5
			SHC	-	157.0	218.9	-	151.2	212.9	-	145.1	206.3	-	138.5	199.3	-	131.5	191.7

NOTE: See Minimum–Maximum Airflow Ratings in Table 5. Do not operate outside these limits.

LEGEND:

- Do not operate
- Cfm - Cubic feet per minute (supply air)
- EAT (db) - Entering Air Temperature (dry bulb)
- EAT (wb) - Entering Air Temperature (wet bulb)
- SHC - Sensible Heat Capacity (1000 Btuh) Gross
- TC - Total Capacity (1000 Btuh) Gross

48HC*E28 (25 TONS) – UNIT WITH HUMIDI-MIZER IN SUBCOOLING MODE										
Temp (F) Air Ent Condenser (Edb)		AIR ENTERING EVAPORATOR – CFM								
		7,500			10,000			12,500		
		Air Entering Evaporator – Ewb (F)								
		72	67	62	72	67	62	72	67	62
75	TC	351.3	319.5	287.8	370.4	337.3	304.1	385.8	351.5	317.2
	SHC	166.5	199.4	232.3	191.2	245.6	258.5	211.4	245.6	279.9
	kW	16.75	16.55	15.20	17.30	16.75	15.85	17.80	17.50	16.50
85	TC	327.5	296.4	265.3	346.1	313.6	281.2	361.1	327.5	294.0
	SHC	137.4	178.2	219.0	162.6	204.5	246.4	183.3	226.0	268.7
	kW	18.65	18.45	17.25	19.20	18.65	17.80	19.45	19.15	18.15
95	TC	303.7	273.3	242.9	321.8	290.0	258.3	336.4	303.5	270.7
	SHC	108.2	157.0	205.8	134.0	184.1	234.3	155.1	206.4	257.6
	kW	20.60	20.40	19.34	21.15	20.60	19.95	21.60	21.30	20.30
105	TC	279.9	250.2	220.4	297.5	266.4	235.3	311.7	279.5	247.4
	SHC	79.0	135.8	192.5	105.4	163.8	222.2	127.1	186.7	246.4
	kW	22.85	22.65	21.45	23.40	22.85	22.05	23.70	23.40	22.40
115	TC	256.2	227.1	198.0	273.2	242.8	212.4	287.0	255.5	224.1
	SHC	49.9	114.5	179.2	76.8	143.4	210.1	98.9	167.1	223.8
	kW	25.05	24.85	23.65	25.60	25.05	24.25	25.90	25.60	24.60
125	TC	232.4	203.9	175.5	248.9	219.2	189.5	262.3	231.5	200.8
	SHC	20.7	93.3	166.0	48.2	123.1	188.9	70.8	147.4	200.8
	kW	27.25	27.05	25.80	27.80	27.25	26.50	28.15	27.85	26.85

48HC*E28 (25 TONS) – UNIT WITH HUMIDI-MIZER IN HOT GAS REHEAT MODE										
Temp (F) Air Ent Condenser (Edb)		AIR ENTERING EVAPORATOR (F)								
		75 Dry Bulb			75 Dry Bulb			75 Dry Bulb		
		62.5 Wet Bulb			64 Wet Bulb			65.3 Wet Bulb		
		(50% Relative)			(56% Relative)			(60% Relative)		
		Air Entering Evaporator – Cfm								
7,500	10,000	12,500	7,500	10,000	12,500	7,500	10,000	12,500		
80	TC	124.40	133.90	139.00	132.00	142.10	145.10	135.60	149.10	151.50
	SHC	37.60	60.70	82.20	27.80	45.40	65.80	17.50	34.20	50.10
	kW	15.83	15.90	16.00	15.97	16.13	16.16	16.11	16.31	16.38
75	TC	129.00	138.50	144.60	136.60	147.60	150.10	140.60	154.00	156.30
	SHC	47.10	70.60	92.10	37.30	55.30	75.70	27.00	43.70	60.00
	kW	15.77	15.83	15.94	15.91	16.07	16.10	16.05	16.25	16.32
70	TC	133.60	143.10	149.20	141.20	152.30	154.80	145.30	158.80	161.10
	SHC	57.30	80.70	102.20	47.50	65.40	85.80	37.20	53.90	70.10
	kW	15.68	15.75	15.86	15.83	16.00	16.04	15.88	16.08	16.15
60	TC	142.80	158.40	158.40	150.40	161.40	163.90	153.90	167.40	169.70
	SHC	76.50	121.40	121.40	66.70	84.60	105.00	56.40	73.10	89.30
	kW	15.54	15.60	15.71	15.68	15.84	15.87	15.82	16.02	16.09
50	TC	151.80	161.30	167.40	159.40	170.50	173.20	162.80	176.20	178.80
	SHC	94.10	117.50	139.00	84.30	102.20	122.60	74.00	90.70	106.90
	kW	15.40	15.47	15.58	15.54	15.68	15.71	15.66	15.86	15.93
40	TC	161.20	170.70	176.80	168.80	179.80	182.50	172.20	185.70	188.20
	SHC	114.10	137.60	159.10	104.30	122.30	142.70	94.00	110.70	127.00
	kW	15.24	15.31	15.42	15.39	15.55	15.58	15.53	15.73	15.80

LEGEND

- Edb** – Entering Dry–Bulb
- Ewb** – Entering Wet–Bulb
- kW** – Compressor Motor Power Input
- ldb** – Leaving Dry–Bulb
- lwb** – Leaving Wet–Bulb
- SHC** – Sensible Heat Capacity (1000 Btuh) Gross
- TC** – Total Capacity (1000 Btuh) Gross

NOTES:

1. Direct interpolation is permissible. Do not extrapolate.
2. The following formulas may be used:

$$t_{ldb} = t_{edb} - \frac{\text{sensible capacity (Btuh)}}{1.10 \times \text{cfm}}$$

t_{lwb} = Wet–bulb temperature corresponding to enthalpy of air leaving evaporator coil (h_{lwb})

$$h_{lwb} = h_{ewb} - \frac{\text{total capacity (Btuh)}}{4.5 \times \text{cfm}}$$

Where: h_{ewb} = Enthalpy of air entering evaporator coil

Table 16 – STATIC PRESSURE ADDERS (IN. WG) - Factory Options and/or Accessories

Humidi-MiZer® Coil

15 – 17.5 Tons												
CFM	3750	4750	5750	6750	7750	8750	9750	10750	11750	12750	13750	
Pressure Drop (in. wg)	0.03	0.04	0.06	0.07	0.09	0.10	0.12	0.14	0.16	0.19	0.21	

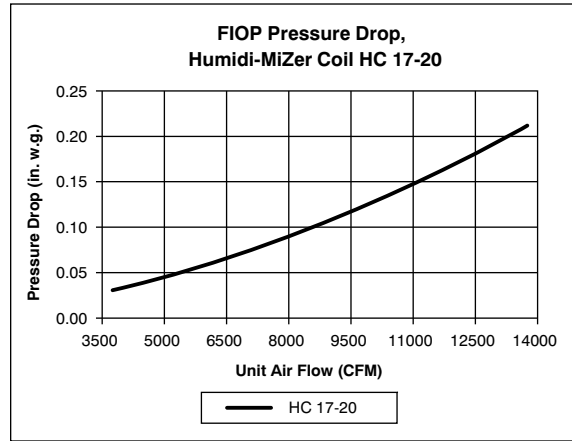

C160096

20 – 25 Tons												
CFM	3750	4750	5750	6750	7750	8750	9750	10750	11750	12750	13750	
Pressure Drop (in. wg)	0.02	0.03	0.04	0.05	0.07	0.08	0.09	0.11	0.13	0.14	0.16	

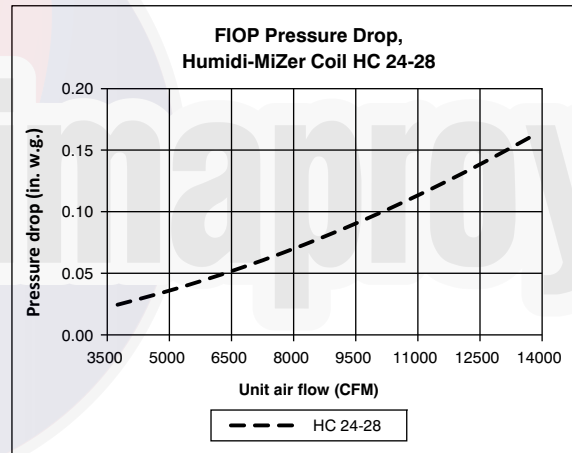

C160097

Economizers

15 – 25 Tons											
CFM	4750	5750	6750	7750	8750	9750	10750	11750	12750	13750	
Pressure Drop (in. wg)	0.00	0.01	0.01	0.02	0.03	0.05	0.06	0.07	0.09	0.11	

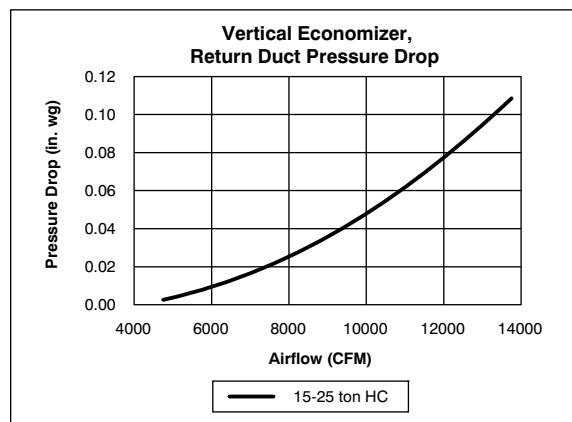

C160098

DAMPER, BAROMETRIC RELIEF AND PE PERFORMANCE

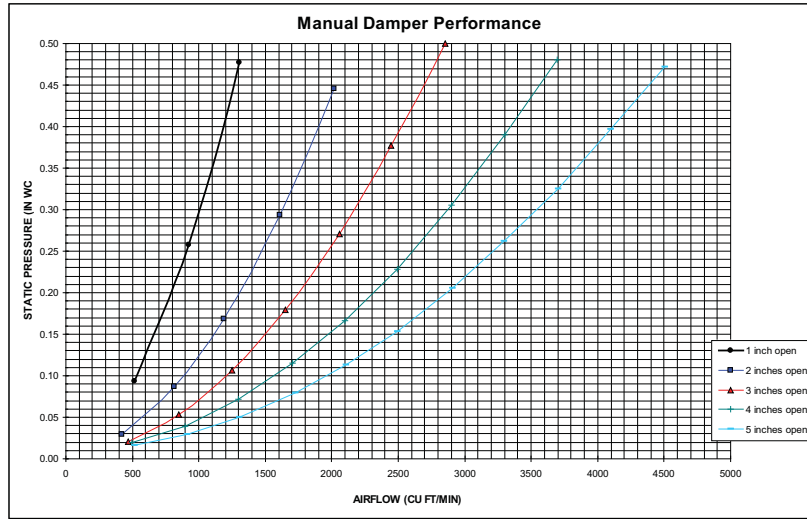

Fig. 16 - Manual Damper Performance

C09264

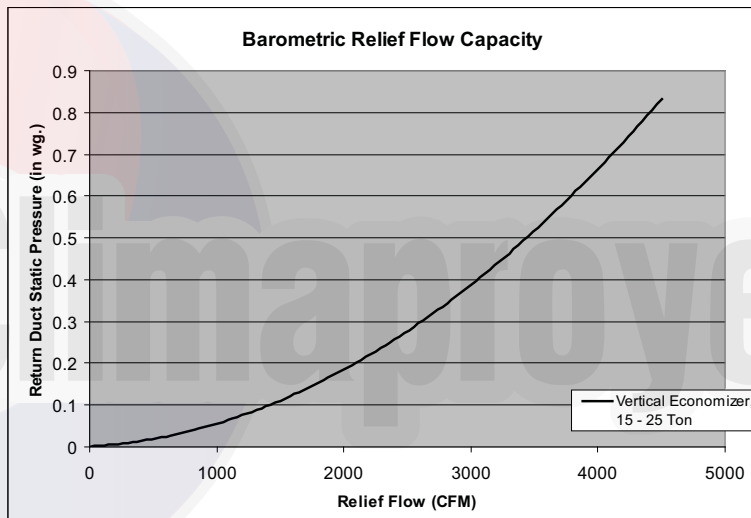

Fig. 17 - Barometric Relief Flow Capacity

C101044

Power Exhaust Fan Performance

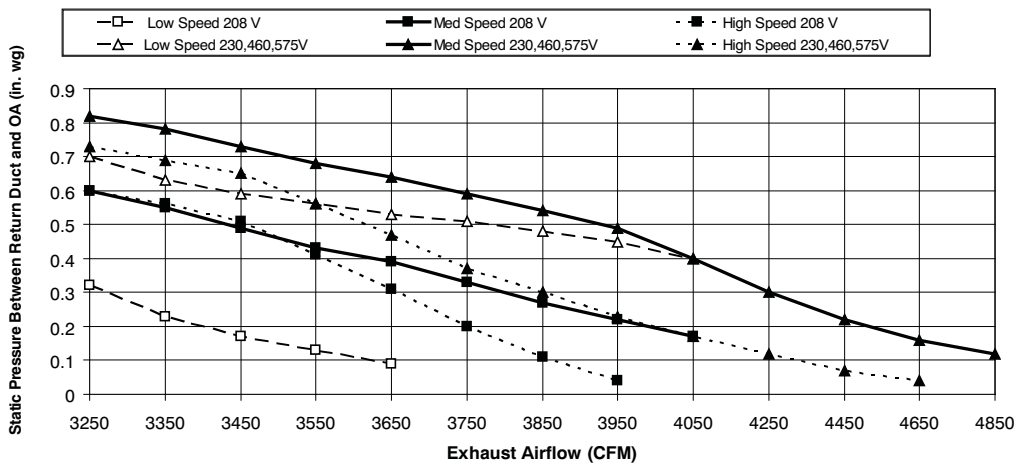

Fig. 18 - Power Exhaust Fan Performance

C09270

GENERAL FAN PERFORMANCE NOTES:

1. Interpolation is permissible. Do not extrapolate.
2. External static pressure is the static pressure difference between the return duct and the supply duct plus the static pressure caused by any FIOPs or accessories.
3. Tabular data accounts for pressure loss due to clean filters, high gas heat, unit casing, and wet coils. Factory options and accessories may add static pressure losses. Selection software is available, through your salesperson, to help you select the best motor/drive combination for your application.
4. The Fan Performance tables offer motor/drive recommendations. In cases when two motor/drive combinations would work, Carrier recommended the lower horsepower option.
5. For information on the electrical properties of Carrier motors, please see the Electrical information section of this book.
6. For more information on the performance limits of Carrier motors, see the application data section of this book.



FAN PERFORMANCE

Table 17 – 48HC**I7

15 TON VERTICAL SUPPLY

CFM	Available External Static Pressure (in. wg)																			
	0.2		0.4		0.6		0.8		1.0		1.2		1.4		1.6		1.8		2.0	
	RPM	BHP	RPM	BHP	RPM	BHP	RPM	BHP	RPM	BHP	RPM	BHP	RPM	BHP	RPM	BHP	RPM	BHP	RPM	BHP
4500	494	0.77	583	1.09	662	1.43	732	1.80	796	2.19	856	2.60	911	3.02	963	3.46	1012	3.92	1059	4.39
4900	522	0.93	605	1.27	681	1.64	750	2.03	813	2.44	871	2.86	926	3.30	977	3.76	1026	4.23	1072	4.72
5250	547	1.10	626	1.45	700	1.84	766	2.24	828	2.67	885	3.11	939	3.57	990	4.05	1038	4.54	-	-
5650	577	1.32	651	1.68	721	2.09	786	2.51	846	2.96	903	3.43	956	3.91	1006	4.40	-	-	-	-
6000	603	1.53	674	1.91	741	2.33	804	2.78	863	3.24	918	3.72	971	4.22	1020	4.73	-	-	-	-
6400	634	1.81	701	2.20	765	2.64	826	3.10	883	3.59	937	4.09	988	4.61	-	-	-	-	-	-
6750	662	2.07	725	2.49	787	2.94	846	3.42	902	3.92	954	4.44	-	-	-	-	-	-	-	-
7150	694	2.42	754	2.85	813	3.31	869	3.81	923	4.33	975	4.87	-	-	-	-	-	-	-	-
7500	722	2.74	779	3.19	836	3.67	890	4.19	943	4.72	-	-	-	-	-	-	-	-	-	-

STD Static – 514 – 680 RPM, 2.9 Max BHP

MED Static – 679 – 863 RPM, 3.7 Max BHP

HIGH Static – 826 – 1009 RPM, 4.9 Max BHP

BOLD – requires alternate standard static drive package

ITALICS – requires high static drive package with different motor pulley.

For more information, see General Fan Performance Notes on page 43.

Table 18 – 48HC**I7

15 TON HORIZONTAL SUPPLY

CFM	Available External Static Pressure (in. wg)																			
	0.2		0.4		0.6		0.8		1.0		1.2		1.4		1.6		1.8		2.0	
	RPM	BHP	RPM	BHP	RPM	BHP	RPM	BHP	RPM	BHP	RPM	BHP	RPM	BHP	RPM	BHP	RPM	BHP	RPM	BHP
4500	508	1.25	582	1.76	647	2.31	705	2.89	758	3.51	807	4.16	852	4.83	-	-	-	-	-	-
4900	540	1.51	610	2.05	672	2.64	729	3.26	781	3.91	829	4.58	-	-	-	-	-	-	-	-
5250	568	1.78	635	2.35	695	2.96	750	3.61	801	4.29	-	-	-	-	-	-	-	-	-	-
5650	600	2.13	664	2.73	723	3.37	776	4.05	825	4.76	-	-	-	-	-	-	-	-	-	-
6000	629	2.47	691	3.10	747	3.77	799	4.48	-	-	-	-	-	-	-	-	-	-	-	-
6400	663	2.91	721	3.57	776	4.28	-	-	-	-	-	-	-	-	-	-	-	-	-	-
6750	693	3.34	749	4.03	801	4.76	-	-	-	-	-	-	-	-	-	-	-	-	-	-
7150	727	3.88	781	4.61	-	-	-	-	-	-	-	-	-	-	-	-	-	-	-	-
7500	757	4.40	-	-	-	-	-	-	-	-	-	-	-	-	-	-	-	-	-	-

STD Static – 514 – 680 RPM, 2.9 Max BHP

MED Static – 614 – 780 RPM, 3.7 Max BHP

HIGH Static – 746 – 912 RPM, 4.9 Max BHP

For more information, see General Fan Performance Notes on page 43.

FAN PERFORMANCE (cont.)

Table 19 – 48HC20**

17.5 TON VERTICAL SUPPLY

CFM	Available External Static Pressure (in. wg)																			
	0.2		0.4		0.6		0.8		1.0		1.2		1.4		1.6		1.8		2.0	
	RPM	BHP	RPM	BHP	RPM	BHP	RPM	BHP	RPM	BHP	RPM	BHP	RPM	BHP	RPM	BHP	RPM	BHP	RPM	BHP
5250	547	1.10	626	1.45	700	1.84	766	2.24	828	2.67	885	3.11	939	3.57	990	4.05	1038	4.54	1084	5.04
5700	581	1.35	655	1.72	724	2.12	789	2.55	849	3.00	905	3.47	958	3.95	1008	4.45	1055	4.96	1100	5.48
6150	615	1.63	684	2.02	750	2.44	812	2.90	871	3.37	925	3.86	977	4.36	1026	4.88	1073	5.42	1118	5.96
6550	646	1.92	711	2.32	774	2.77	834	3.24	891	3.73	945	4.24	995	4.76	1043	5.30	1090	5.86	1134	6.42
7000	682	2.28	743	2.71	803	3.17	860	3.66	915	4.17	967	4.71	1017	5.26	1064	5.82	1109	6.39	-	-
7450	718	2.70	775	3.14	832	3.62	887	4.13	940	4.67	991	5.22	1039	5.79	1085	6.38	-	-	-	-
7900	755	3.16	809	3.62	863	4.12	915	4.65	966	5.21	1015	5.78	1062	6.38	-	-	-	-	-	-
8300	787	3.62	839	4.09	891	4.61	941	5.16	990	5.73	1038	6.33	-	-	-	-	-	-	-	-
8750	825	4.18	874	4.68	923	5.22	971	5.78	1018	6.38	-	-	-	-	-	-	-	-	-	-

STD Static – 622–822 RPM, 3.7 Max BHP

MED Static – 713–879 RPM, 4.9 Max BHP

HIGH Static – 882–1078 RPM

Voltage: 208V / 230V / 460V / 575V, Max BHP: 6.5 / 6.9 / 7.0 / 8.3

BOLD – requires alternate standard static drive package

BLACK – requires high static drive package with different motor pulley. Confirm Max BHP based on unit voltage selected.

For more information, see General Fan Performance Notes on page 43.

Table 20 – 48HC20**

17.5 TON HORIZONTAL SUPPLY

CFM	Available External Static Pressure (in. wg)																			
	0.2		0.4		0.6		0.8		1.0		1.2		1.4		1.6		1.8		2.0	
	RPM	BHP	RPM	BHP	RPM	BHP	RPM	BHP	RPM	BHP	RPM	BHP	RPM	BHP	RPM	BHP	RPM	BHP	RPM	BHP
5250	568	1.78	635	2.35	695	2.96	750	3.61	801	4.29	848	4.99	893	5.72	934	6.47	974	7.25	1012	8.05
5700	604	2.17	668	2.78	726	3.43	779	4.11	829	4.82	875	5.56	918	6.33	959	7.12	998	7.93	-	-
6150	642	2.63	702	3.27	758	3.95	809	4.67	857	5.42	902	6.20	944	7.00	985	7.83	-	-	-	-
6550	676	3.09	733	3.76	786	4.48	836	5.23	883	6.01	927	6.82	968	7.65	-	-	-	-	-	-
7000	714	3.67	769	4.38	820	5.14	868	5.92	913	6.74	955	7.58	-	-	-	-	-	-	-	-
7450	753	4.33	805	5.08	854	5.87	900	6.69	944	7.54	-	-	-	-	-	-	-	-	-	-
7900	792	5.06	841	5.85	888	6.68	933	7.54	-	-	-	-	-	-	-	-	-	-	-	-
8300	827	5.78	874	6.61	920	7.47	-	-	-	-	-	-	-	-	-	-	-	-	-	-
8750	867	6.69	912	7.55	-	-	-	-	-	-	-	-	-	-	-	-	-	-	-	-

STD Static – 622–822 RPM, 3.7 Max BHP

MED Static – 713–879 RPM, 4.9 Max BHP

HIGH Static – 835–1021 RPM

Voltage: 208V / 230V / 460V / 575V, Max BHP: 6.5 / 6.9 / 7.0 / 8.3

BOLD – requires alternate standard static drive package

BLACK – requires high static drive package with different motor pulley. Confirm Max BHP based on unit voltage selected.

For more information, see General Fan Performance Notes on page 43.

FAN PERFORMANCE (cont.)

Table 21 – 48HC**24

20 TON VERTICAL SUPPLY

CFM	Available External Static Pressure (in. wg)																			
	0.2		0.4		0.6		0.8		1.0		1.2		1.4		1.6		1.8		2.0	
	RPM	BHP	RPM	BHP	RPM	BHP	RPM	BHP	RPM	BHP	RPM	BHP	RPM	BHP	RPM	BHP	RPM	BHP	RPM	BHP
6000	615	1.25	690	1.56	757	1.89	819	2.22	875	2.57	928	2.92	978	3.28	1025	3.65	1071	4.03	1114	4.42
6500	653	1.52	725	1.87	789	2.21	848	2.57	903	2.94	955	3.31	1003	3.69	1050	4.09	1094	4.49	1137	4.89
7000	692	1.85	760	2.21	822	2.58	879	2.96	932	3.35	983	3.75	1030	4.15	1075	4.56	1119	4.98	1161	5.41
7500	731	2.21	796	2.60	856	3.00	911	3.40	963	3.81	1011	4.23	1058	4.66	1102	5.09	1145	5.53	1186	5.98
8000	771	2.63	833	3.04	890	3.47	944	3.89	994	4.33	1041	4.77	1087	5.21	1130	5.67	1171	6.13	-	-
8500	812	3.10	871	3.54	926	3.98	977	4.43	1026	4.89	1072	5.35	1116	5.82	1158	6.30	-	-	-	-
9000	852	3.62	909	4.09	961	4.55	1011	5.03	1059	5.51	1104	6.00	1147	6.49	1188	6.99	-	-	-	-
9500	893	4.20	947	4.69	998	5.19	1046	5.69	1092	6.19	1136	6.70	1178	7.22	-	-	-	-	-	-
10000	934	4.85	986	5.36	1035	5.88	1082	6.40	1126	6.93	1169	7.47	-	-	-	-	-	-	-	-

STD Static – 690–863 RPM
Voltage: 208V / 230V / 460V / 575V
Max BHP: 6.5 / 6.9 / 7.0 / 8.3

MED Static – 835–1021 RPM
Voltage: 208V / 230V / 460V / 575V
Max BHP: 6.5 / 6.9 / 7.0 / 8.3

HIGH Static – 941–1176 RPM
Voltage: 208V / 230V / 460V / 575V
Max BHP: 10.5 / 11.9 / 11.9 / 11.0

BOLD – requires alternate standard static drive package

ITALICS – requires high static drive package with different motor pulley. All voltages

For more information, see General Fan Performance Notes on page 43.

Table 22 – 48HC**24

20 TON HORIZONTAL SUPPLY

CFM	Available External Static Pressure (in. wg)																			
	0.2		0.4		0.6		0.8		1.0		1.2		1.4		1.6		1.8		2.0	
	RPM	BHP	RPM	BHP	RPM	BHP	RPM	BHP	RPM	BHP	RPM	BHP	RPM	BHP	RPM	BHP	RPM	BHP	RPM	BHP
6000	633	1.92	700	2.44	759	2.98	812	3.53	861	4.10	907	4.68	949	5.27	990	5.88	1028	6.50	1064	7.13
6500	674	2.34	738	2.90	795	3.48	847	4.07	894	4.67	939	5.29	981	5.92	1020	6.56	1058	7.21	1094	7.88
7000	715	2.83	776	3.43	831	4.05	882	4.67	928	5.31	972	5.97	1013	6.63	1052	7.31	1089	8.00	-	-
7500	757	3.39	816	4.03	869	4.68	917	5.35	963	6.03	1005	6.72	1046	7.42	1084	8.13	-	-	-	-
8000	800	4.02	856	4.70	907	5.39	954	6.10	998	6.81	1040	7.54	1079	8.28	-	-	-	-	-	-
8500	843	4.73	896	5.45	945	6.18	991	6.93	1034	7.68	1075	8.45	-	-	-	-	-	-	-	-
9000	886	5.52	937	6.28	984	7.06	1029	7.84	1071	8.63	-	-	-	-	-	-	-	-	-	-
9500	929	6.40	978	7.21	1024	8.02	1067	8.84	-	-	-	-	-	-	-	-	-	-	-	-
10000	973	7.38	1020	8.22	1064	9.08	-	-	-	-	-	-	-	-	-	-	-	-	-	-

STD Static – 690–863 RPM
Voltage: 208V / 230V / 460V / 575V
Max BHP: 6.5 / 6.9 / 7.0 / 8.3

MED Static – 835–1021 RPM
Voltage: 208V / 230V / 460V / 575V
Max BHP: 6.5 / 6.9 / 7.0 / 8.3

HIGH Static – 941–1176 RPM
Voltage: 208V / 230V / 460V / 575V
Max BHP: 10.5 / 11.9 / 11.9 / 11.0

BOLD – requires alternate standard static drive package

UNDERSCORE – Operation point covered by MED static drive. Confirm Max BHP coverage based on unit voltage selected.

For more information, see General Fan Performance Notes on page 43.

FAN PERFORMANCE (cont.)

Table 23 – 48HC28**

25 TON VERTICAL SUPPLY

CFM	Available External Static Pressure (in. wg)																			
	0.2		0.4		0.6		0.8		1.0		1.2		1.4		1.6		1.8		2.0	
	RPM	BHP	RPM	BHP	RPM	BHP	RPM	BHP	RPM	BHP	RPM	BHP	RPM	BHP	RPM	BHP	RPM	BHP	RPM	BHP
7500	731	2.21	796	2.60	856	3.00	911	3.40	963	3.81	1011	4.23	1058	4.66	1102	5.09	1145	5.53	1186	5.98
8150	783	2.76	844	3.19	901	3.61	954	4.05	1003	4.49	1050	4.94	1095	5.39	1138	5.85	1180	6.32	-	-
8750	832	3.35	890	3.80	943	4.26	994	4.73	1042	5.19	1088	5.67	1131	6.15	1173	6.64	-	-	-	-
9400	885	4.08	940	4.57	991	5.06	1039	5.55	1085	6.05	1129	6.56	1172	7.07	-	-	-	-	-	-
10000	934	4.85	986	5.36	1035	5.88	1082	6.40	1126	6.93	1169	7.47	-	-	-	-	-	-	-	-
10650	988	5.78	1038	6.33	1084	6.88	1129	7.44	1172	8.00	-	-	-	-	-	-	-	-	-	-
11250	1038	6.74	1086	7.32	1130	7.91	1173	8.49	-	-	-	-	-	-	-	-	-	-	-	-
11900	1093	7.91	1138	8.52	1181	9.14	-	-	-	-	-	-	-	-	-	-	-	-	-	-
12500	1144	9.10	1187	9.74	-	-	-	-	-	-	-	-	-	-	-	-	-	-	-	-

STD Static – 717–911 RPM, 4.9 Max BHP

MED Static – 913–1116 RPM
Voltage: 208V / 230V / 460V / 575V
Max BHP: 6.5 / 6.9 / 7.0 / 8.3

HIGH Static – 941–1176 RPM
Voltage: 208V / 230V / 460V / 575V
Max BHP: 10.5 / 11.9 / 11.9 / 11.0

ITALICS – requires high static drive package with different motor pulley.

UNDERScore – Operation point covered by MED static drive. Confirm Max BHP coverage based on unit voltage selected.
For more information, see General Fan Performance Notes on page 43.

Table 24 – 48HC28**

25 TON HORIZONTAL SUPPLY

CFM	Available External Static Pressure (in. wg)																			
	0.2		0.4		0.6		0.8		1.0		1.2		1.4		1.6		1.8		2.0	
	RPM	BHP	RPM	BHP	RPM	BHP	RPM	BHP	RPM	BHP	RPM	BHP	RPM	BHP	RPM	BHP	RPM	BHP	RPM	BHP
7500	757	3.39	816	4.03	869	4.68	917	5.35	963	6.03	1005	6.72	1046	7.42	1084	8.13	-	-	-	-
8000	800	4.02	856	4.70	907	5.39	954	6.10	998	6.81	1040	7.54	1079	8.28	-	-	-	-	-	-
8500	843	4.73	896	5.45	945	6.18	991	6.93	1034	7.68	1075	8.45	-	-	-	-	-	-	-	-
9000	886	5.52	937	6.28	984	7.06	1029	7.84	1071	8.63	-	-	-	-	-	-	-	-	-	-
9500	929	6.40	978	7.21	1024	8.02	1067	8.84	-	-	-	-	-	-	-	-	-	-	-	-
10000	973	7.38	1020	8.22	1064	9.08	-	-	-	-	-	-	-	-	-	-	-	-	-	-
10500	1017	8.45	1062	9.33	-	-	-	-	-	-	-	-	-	-	-	-	-	-	-	-
11000	1061	9.63	-	-	-	-	-	-	-	-	-	-	-	-	-	-	-	-	-	-
11500	-	-	-	-	-	-	-	-	-	-	-	-	-	-	-	-	-	-	-	-

MED Static – 755–923 RPM
Voltage: 208V / 230V / 460V / 575V
Max BHP: 6.5 / 6.9 / 7.0 / 8.3

HIGH Static – 906–1100 RPM
Voltage: 208V / 230V / 460V / 575V
Max BHP: 10.5 / 11.9 / 11.9 / 11.0

BOLD – requires alternate standard static drive package
For more information, see General Fan Performance Notes on page 43

FAN PERFORMANCE (cont.)

Table 25 – PULLEY ADJUSTMENT

Vertical

MODEL SIZE	MOTOR/DRIVE COMBO	MOTOR PULLEY TURNS OPEN										
		0	0.5	1	1.5	2	2.5	3	3.5	4	4.5	5
17	Standard Static	680	663	647	630	614	597	580	564	547	531	514
	Medium Static	863	845	826	808	789	771	753	734	716	697	679
	High Static	1009	991	972	954	936	918	899	881	863	844	826
20	Standard Static	822	802	782	762	742	722	702	682	662	642	622
	Medium Static	879	862	846	829	813	796	779	763	746	730	713
	High Static	1078	1058	1039	1019	1000	980	960	941	921	902	882
24	Standard Static	863	846	828	811	794	777	759	742	725	707	690
	Medium Static	1021	1002	984	965	947	928	909	891	872	854	835
	High Static	1176	1153	1129	1106	1082	1059	1035	1012	988	965	941
28	Standard Static	911	892	872	853	833	814	795	775	756	736	717
	Medium Static	1116	1096	1075	1055	1035	1015	994	974	954	933	913
	High Static	1176	1153	1129	1106	1082	1059	1035	1012	988	965	941

NOTE: Do not adjust pulley further than 5 turns open.

■ – Factory settings

Horizontal

MODEL SIZE	MOTOR/DRIVE COMBO	MOTOR PULLEY TURNS OPEN										
		0	0.5	1	1.5	2	2.5	3	3.5	4	4.5	5
17	Standard Static	680	663	647	630	614	597	580	564	547	531	514
	Medium Static	780	763	747	730	714	697	680	664	647	631	614
	High Static	912	895	879	862	846	829	812	796	779	763	746
20	Standard Static	822	802	782	762	742	722	702	682	662	642	622
	Medium Static	879	862	846	829	813	796	779	763	746	730	713
	High Static	1021	1002	984	965	947	928	909	891	872	854	835
24	Standard Static	863	846	828	811	794	777	759	742	725	707	690
	Medium Static	1021	1002	984	965	947	928	909	891	872	854	835
	High Static	1176	1153	1129	1106	1082	1059	1035	1012	988	965	941
28	*Standard Static	–	–	–	–	–	–	–	–	–	–	–
	Medium Static	923	906	889	873	856	839	822	805	789	772	755
	High Static	1107	1187	1067	1047	1027	1007	986	966	946	926	906

NOTE: Do not adjust pulley further than 5 turns open.

* 48HC size 28 uses a field supplied drive

■ – Factory settings

ELECTRICAL INFORMATION

Table 26 – 2-STAGE COOLING WITH SINGLE SPEED INDOOR FAN MOTOR

UNIT	V-Ph-Hz	VOLTAGE RANGE		COMP 1		COMP 2		OFM (ea)		IFM		
		MIN	MAX	RLA	LRA	RLA	LRA	WATTS	FLA	TYPE	EFF at Full Load	FLA
17	208-3-60	187	253	25.0	164	25.0	164	350	1.5	STD	81.3%	7.5
										MED	87.0%	10.6
										HIGH	82.9%	13.6
	230-3-60	187	253	25.0	164	25.0	164	350	1.5	STD	81.3%	7.5
										MED	87.0%	10.6
										HIGH	82.9%	12.7
	460-3-60	414	506	12.8	100	12.8	100	277	0.9	STD	81.3%	7.5
										MED	87.0%	5.3
										HIGH	82.9%	6.4
	575-3-60	518	633	9.6	78	9.6	78	397	0.6	STD	81.1%	2.8
										MED	81.1%	2.8
										HIGH	83.6%	5.6
20	208-3-60	187	253	27.6	191	25.0	164	350	1.5	STD	83.8%	10.2
										MED	82.9%	13.6
										HIGH/High-Efficiency	89.5%	17.1
	230-3-60	187	253	27.6	191	25.0	164	350	1.5	STD	83.8%	10.2
										MED	82.9%	12.7
										HIGH/High-Efficiency	89.5%	17.1
	460-3-60	414	506	12.8	100	12.2	100	277	0.9	STD	83.8%	4.8
										MED	82.9%	6.4
										HIGH/High-Efficiency	89.5%	8.6
	575-3-60	518	633	9.6	78	9.0	78	397	0.6	STD	81.1%	2.8
										MED	83.6%	5.6
										HIGH/High-Efficiency	89.5%	7.6
24	208-3-60	187	253	28.2	239	28.2	239	350	1.5	STD/High-Efficiency	89.5%	17.7
										MED/High-Efficiency	89.5%	17.1
										HIGH/High-Efficiency	91.7%	28.5
	230-3-60	187	253	28.2	239	28.2	239	350	1.5	STD/High-Efficiency	89.5%	17.1
										MED/High-Efficiency	89.5%	17.1
										HIGH/High-Efficiency	91.7%	28.5
	460-3-60	414	506	14.7	130	14.7	130	277	0.9	STD/High-Efficiency	89.5%	8.6
										MED/High-Efficiency	89.5%	8.6
										HIGH/High-Efficiency	91.7%	14.3
	575-3-60	518	633	11.3	94	11.3	94	397	0.6	STD/High-Efficiency	83.6%	5.6
										MED/High-Efficiency	89.5%	7.6
										HIGH/High-Efficiency	91.7%	9.5
28	208-3-60	187	253	48.1	245	33.9	240	350	1.5	STD	82.9%	13.6
										MED/High-Efficiency	89.5%	17.1
										HIGH/High-Efficiency	91.7%	28.5
	230-3-60	187	253	48.1	245	33.9	240	350	1.5	STD	82.9%	12.7
										MED/High-Efficiency	89.5%	17.1
										HIGH/High-Efficiency	91.7%	28.5
	460-3-60	414	506	18.6	125	16.0	140	277	0.9	STD	82.9%	6.4
										MED/High-Efficiency	89.5%	8.6
										HIGH/High-Efficiency	91.7%	14.3
	575-3-60	518	633	14.7	100	12.9	108	397	0.6	STD	83.6%	5.6
										MED/High-Efficiency	89.5%	7.6
										HIGH/High-Efficiency	91.7%	9.5

NOTE: STD static is not available on 48HC**28 horizontal units.

See: "Legend and Notes for Tables 26 – 31" on page 59.

ELECTRICAL INFORMATION (cont.)

Table 27 – 2-STAGE COOLING WITH 2-SPEED INDOOR FAN MOTOR

UNIT	V-Ph-Hz	VOLTAGE RANGE		COMP 1		COMP 2		OFM (ea)		IFM		
		MIN	MAX	RLA	LRA	RLA	LRA	WATTS	FLA	TYPE	EFF at Full Load	FLA
17	208-3-60	187	253	25.0	164	25.0	164	350	1.5	STD	85.0%	8.6
										MED	81.5%	10.8
										HIGH	83.6%	13.6
	230-3-60	187	253	25.0	164	25.0	164	350	1.5	STD	85.0%	7.8
										MED	81.5%	9.8
										HIGH	83.6%	12.7
	460-3-60	414	506	12.8	100	12.8	100	277	0.9	STD	85.0%	3.8
										MED	81.5%	4.9
										HIGH	83.6%	6.4
	575-3-60	518	633	9.6	78	9.6	78	397	0.6	STD	81.1%	4.5
										MED	81.1%	4.5
										HIGH	83.6%	6.2
20	208-3-60	187	253	27.6	191	25.0	164	350	1.5	STD	81.5%	10.8
										MED	83.6%	13.6
										HIGH	89.5%	17.1
	230-3-60	187	253	27.6	191	25.0	164	350	1.5	STD	81.5%	9.8
										MED	83.6%	12.7
										HIGH	89.5%	17.1
	460-3-60	414	506	12.8	100	12.2	100	277	0.9	STD	81.5%	4.9
										MED	83.6%	6.4
										HIGH	89.5%	8.6
	575-3-60	518	633	9.6	78	9.0	78	397	0.6	STD	81.1%	4.5
										MED	83.6%	6.2
										HIGH	89.5%	7.6
24	208-3-60	187	253	28.2	239	28.2	239	350	1.5	STD	83.6%	13.6
										MED	89.5%	17.1
										HIGH	91.7%	28.5
	230-3-60	187	253	28.2	239	28.2	239	350	1.5	STD	83.6%	12.7
										MED	89.5%	17.1
										HIGH	91.7%	28.5
	460-3-60	414	506	14.7	130	14.7	130	277	0.9	STD	83.6%	6.4
										MED	89.5%	8.6
										HIGH	91.7%	14.3
	575-3-60	518	633	11.3	94	11.3	94	397	0.6	STD	83.6%	6.2
										MED	89.5%	7.6
										HIGH	91.7%	9.5
28	208-3-60	187	253	48.1	245	33.9	240	350	1.5	STD	83.6%	13.6
										MED	89.5%	17.1
										HIGH	91.7%	28.5
	230-3-60	187	253	48.1	245	33.9	240	350	1.5	STD	83.6%	12.7
										MED	89.5%	17.1
										HIGH	91.7%	28.5
	460-3-60	414	506	18.6	125	16.0	140	277	0.9	STD	83.6%	6.4
										MED	89.5%	8.6
										HIGH	91.7%	14.3
	575-3-60	518	633	14.7	100	12.9	108	397	0.6	STD	83.6%	6.2
										MED	89.5%	7.6
										HIGH	91.7%	9.5

NOTE: STD static is not available on 48HC**28 horizontal units.

See: "Legend and Notes for Tables 26 – 31" on page 59.

ELECTRICAL INFORMATION (cont.)

Table 28 – UNIT WIRE/FUSE OR HACR BREAKER SIZING DATA - SINGLE-SPEED INDOOR FAN MOTOR

UNIT	NOM. V-Ph-Hz	IFM TYPE	NO C.O. or UNPWR C.O.						w/ PWRD C.O.										
			NO PE.			w/ P.E. (pwrd fr/ unit)			NO PE.			w/ P.E. (pwrd fr/ unit)							
			MCA	MAX FUSE or HACR BRKR	DISC. SIZE FLA LRA	MCA	MAX FUSE or HACR BRKR	DISC. SIZE FLA LRA	MCA	MAX FUSE or HACR BRKR	DISC. SIZE FLA LRA	MCA	MAX FUSE or HACR BRKR	DISC. SIZE FLA LRA					
48HC**17	208/230-3-60	STD	68.3	90	71	393	80.1	100	85	413	73.1	90	77	398	84.9	100	90	418	
		MED	71.4	90	75	423	83.2	100	88	443	76.2	100	80	428	88.0	100	94	448	
		HIGH	74.4/73.5	90/90	78/77	425	86.2/85.3	100/100	92/91	445	79.2/78.3	100/100	84/83	430	91.0/90.1	100/100	97/96	450	
		STD	34.9	45	36	234	41.1	50	44	246	37.1	45	39	236	43.3	50	46	248	
		MED	36.8	45	39	249	43.0	50	46	261	39.0	50	41	251	45.2	50	48	263	
		HIGH	37.9	50	40	250	44.1	50	47	262	40.1	50	42	252	46.3	50	50	264	
	575-3-60	STD	26.2	30	27	184	31.0	40	33	192	27.9	35	29	186	32.7	40	35	194	
		MED	26.2	30	27	184	31.0	40	33	192	27.9	35	29	186	32.7	40	35	194	
		HIGH	29.0	35	31	198	33.8	40	36	206	30.7	40	33	200	35.5	45	38	208	
		STD	75.7	100	79	440	87.5	100	93	460	80.5	100	85	445	92.3	100	98	465	
		MED	79.1/78.2	100/100	83/82	455	90.9/90.0	100/100	97/96	475	83.9/83.0	100/100	89/88	460	95.7/94.8	110/110	102/101	480	
		HIGH-High Efficiency	82.6	100	87	451	94.4	110	101	471	87.4	100	93	456	99.2	125	106	476	
48HC**20	460-3-60	STD	36.6	45	38	245	42.8	50	46	257	38.8	50	41	247	45.0	50	48	259	
		MED	38.2	50	40	252	44.4	50	47	264	40.4	50	43	254	46.6	50	50	266	
		HIGH-High Efficiency	40.4	50	43	250	46.6	50	50	262	42.6	50	45	252	48.8	60	52	264	
		STD	26.2	30	27	186	31.0	40	33	194	27.9	35	29	188	32.7	40	35	196	
		MED	29.0	35	31	200	33.8	40	36	208	30.7	40	33	202	35.5	45	38	210	
		HIGH-High Efficiency	31.0	40	33	198	35.8	45	38	206	32.7	40	35	200	37.5	45	40	208	
	208/230-3-60	STD	87.3/86.4	100/100	92/91	550	99.1/98.2	125/125	105/104	570	92.1/91.2	100/100	97/96	555	103.9/103.0	125/125	111/110	575	
		MED	90.8	100	96	546	102.6	125	109	566	95.6	125	101	551	107.4	125	115	571	
		HIGH	102.2	125	109	625	114.0	125	122	645	107.0	125	114	630	118.8	150	128	650	
		STD	47.6	60	50	280	53.8	60	57	292	49.8	60	52	282	56	70	60	294	
		MED	49.8	60	52	278	56.0	70	60	290	52.0	60	55	280	58.2	70	62	292	
		HIGH	55.5	60	59	318	61.7	70	66	330	57.7	70	62	320	63.9	80	69	332	
48HC**24 Units produced on or prior to May 15, 2016	575-3-60	STD	35.5	45	37	204	40.3	50	43	212	37.2	45	39	206	42	50	45	214	
		MED	37.5	45	40	202	42.3	50	45	210	39.2	50	42	204	44.0	50	47	212	
		HIGH	39.4	50	42	229	44.2	50	47	237	41.1	50	44	231	45.9	50	49	239	
		STD-High Efficiency	86.6	100	91	574	98.4	125	105	594	91.4	100	97	579	103.2	125	111	599	
		MED-High Efficiency	86.6	100	91	574	98.4	125	105	594	91.4	100	97	579	103.2	125	111	599	
		HIGH-High Efficiency	98.0	125	105	653	108.8	125	118	673	102.8	125	110	668	114.6	125	124	678	
	48HC**24 Units produced on or after May 16, 2016	208/230-3-60	STD-High Efficiency	45.3	50	48	310	51.5	60	55	322	47.5	60	50	312	53.7	60	58	324
			MED-High Efficiency	45.3	50	48	310	51.5	60	55	322	47.5	60	50	312	53.7	60	58	324
			HIGH-High Efficiency	51.0	60	54	350	57.2	70	62	362	53.2	60	57	352	59.4	70	64	364
			STD-High Efficiency	33.4	40	35	232	38.2	45	41	240	35.1	45	37	234	39.9	50	43	242
			MED-High Efficiency	35.4	45	37	230	40.2	50	43	238	37.1	45	39	232	41.9	50	45	240
			HIGH-High Efficiency	37.3	45	40	257	42.1	50	45	265	39.0	50	42	259	43.8	50	47	267

See: "Legend and Notes for Tables 26 – 31" on page 59.

ELECTRICAL INFORMATION (cont.)

Table 28 - UNIT WIRE/FUSE OR HACR BREAKER SIZING DATA - SINGLE-SPEED INDOOR FAN MOTOR (cont.)

UNIT	NOM. V-Ph-Hz	IFM TYPE	NO C.O. or UNPWR C.O.						w/ PWRD C.O.										
			NO PE.			w/ P.E. (pwrd fr/ unit)			NO PE.			w/ P.E. (pwrd fr/ unit)							
			MCA	MAX FUSE or HACR BRKR	DISC. SIZE FLA LRA	MCA	MAX FUSE or HACR BRKR	DISC. SIZE FLA LRA	MCA	MAX FUSE or HACR BRKR	DISC. SIZE FLA LRA	MCA	MAX FUSE or HACR BRKR	DISC. SIZE FLA LRA					
48HC**28 Units produced on or prior to May 15, 2016	208/230-3-60	STD	116.0/115.1	150/150	120/119	590	127.8/126.9	175/175	133/132	610	120.8/119.9	150/150	125/124	595	132.6/131.7	175/175	139/138	615	
		MED	119.5	150	124	586	131.3	175	137	606	124.3	150	129	591	136.1	175	143	611	
	460-3-60	HIGH	130.9	175	137	665	142.7	175	150	685	135.7	175	142	670	147.5	175	156	690	
		STD	53	60	56	306	59.2	70	63	318	55.2	60	58	308	61.4	70	66	320	
	575-3-60	MED	55.2	60	58	304	61.4	70	65	316	57.4	70	61	306	63.6	80	68	318	
		HIGH	60.9	70	65	344	67.1	80	72	356	63.1	80	67	346	69.3	80	74	358	
	48HC**28 1 Units produced on or after May 16, 2016	208/230-3-60	STD	40.4	50	42	228	45.2	50	48	236	42.1	50	44	230	46.9	60	50	238
			MED	42.4	50	45	226	47.2	60	50	234	44.1	50	46	228	48.9	60	52	236
		460-3-60	HIGH	44.3	50	47	253	49.1	60	52	261	46	60	49	255	50.8	60	54	263
			STD	116.6/115.7	150/150	120/119	591	128.4/127.5	175/175	134/133	611	121.4/120.5	150/150	126/125	596	133.2/132.3	175/175	139/138	616
575-3-60		MED-High Efficiency	120.1	150	124	587	131.9	175	138	607	124.9	150	130	592	136.7	175	143	612	
		HIGH-High Efficiency	131.5	175	137	666	143.3	175	151	686	136.3	175	143	671	148.1	175	157	691	
208/230-3-60		STD	51.1	60	53	321	57.3	70	60	333	53.3	60	56	323	59.5	70	63	335	
		MED-High Efficiency	53.3	60	56	319	59.5	70	63	331	55.5	70	58	321	61.7	80	66	333	
460-3-60		HIGH-High Efficiency	59.0	70	62	359	65.2	80	70	371	61.2	70	65	361	67.4	80	72	373	
		STD	40.5	50	42	256	45.3	50	48	264	42.2	50	44	258	47.0	60	50	266	
575-3-60	MED-High Efficiency	42.5	50	45	254	47.3	60	50	262	44.2	50	47	256	49.0	60	52	264		
	HIGH-High Efficiency	44.4	50	47	281	49.2	60	52	289	46.1	60	49	283	50.9	60	54	291		

1 - STD static is not available on 48HC**28 horizontal.

See: "Legend and Notes for Tables 26 - 31" on page 59.

ELECTRICAL INFORMATION(cont.)

Table 29 – UNIT WIRE SIZING DATA WITH FACTORY-INSTALLED HACR BREAKER - SINGLE-SPEED INDOOR FAN MOTOR

UNIT	NOM. V-Ph-Hz	IFM TYPE	NO C.O. or UNPWR C.O.						w/ PWRD C.O.										
			NO RE.			w/ P.E. (pwr'd fr/ unit)			NO PE.			w/ P.E. (pwr'd fr/ unit)							
			MCA	HACR BRKR	DISC. SIZE FLA LRA	MCA	HACR BRKR	DISC. SIZE FLA LRA	MCA	HACR BRKR	DISC. SIZE FLA LRA	MCA	HACR BRKR	DISC. SIZE FLA LRA					
48HC**17	208/230-3-60	STD	68.3	90	71	393	80.1	100	85	413	73.1	90	77	398	84.9	100	90	418	
		MED	71.4	90	75	423	83.2	100	88	443	76.2	100	80	428	88.0	100	94	448	
	460-3-60	HIGH	74.4/74.4	90/90	78/77	425	86.2/86.2	100/100	92/91	445	79.2/79.2	100/100	84/83	430	91.0/91.0	100/100	97/96	450	
		STD	34.9	45	36	234	41.1	50	44	246	37.1	45	39	236	43.3	50	46	248	
	575-3-60	MED	36.8	45	39	249	43.0	50	46	261	38.0	50	41	251	45.2	50	48	263	
		HIGH	37.9	50	40	250	44.1	50	47	262	40.1	50	42	252	46.3	50	50	264	
	208/230-3-60	STD	26.2	30	27	184	31.0	40	33	192	27.9	35	29	186	32.7	40	35	194	
		MED	26.2	30	27	184	31.0	40	33	192	27.9	35	29	186	32.7	40	35	194	
		HIGH	29.0	35	31	198	33.8	40	36	206	30.7	40	33	200	35.5	45	38	208	
		STD	75.7	100	79	440	87.5	100	93	460	80.5	100	85	445	92.3	100	98	465	
48HC**20	460-3-60	MED	79.1/79.1	100/100	83/82	455	90.9/90.9	100/100	97/96	475	83.9/83.9	100/100	89/88	460	95.7/95.7	110/110	102/101	480	
		HIGH-High Efficiency	82.6	100	87	451	94.4	110	101	471	87.4	100	93	456	99.2	125	106	476	
48HC**24 produced on or prior to May 15, 2016	208/230-3-60	STD	36.6	45	38	245	42.8	50	46	257	38.8	50	41	247	45.0	50	48	259	
		MED	38.2	50	40	252	44.4	50	47	264	40.4	50	43	254	46.6	50	50	266	
	460-3-60	HIGH-High Efficiency	40.4	50	43	250	46.6	50	50	262	42.6	50	45	252	48.8	60	52	264	
		STD	26.2	30	27	186	31.0	40	33	194	27.9	35	29	188	32.7	40	35	196	
	575-3-60	MED	29.0	35	31	200	33.8	40	36	208	30.7	40	33	202	35.5	45	38	210	
		HIGH-High Efficiency	31.0	40	33	198	35.8	45	38	206	32.7	40	35	200	37.5	45	40	208	
	48HC**24 produced on or after May 16, 2016	208/230-3-60	STD	87.3/87.3	100/100	92/91	550	99.1/99.1	125/125	105/104	570	92.1/92.1	100/100	97/96	555	103.9/103.9	125/125	111/110	575
			MED	90.8	100	96	546	102.6	125	109	566	95.6	125	101	551	107.4	125	115	571
		460-3-60	HIGH	102.2	125	109	625	114.0	125	122	645	107.0	125	114	630	118.8	150	128	650
			STD	47.6	60	50	280	53.8	60	57	292	48.8	60	52	282	56	70	60	294
575-3-60		MED	49.8	60	52	278	56.0	70	60	290	52.0	60	55	280	58.2	70	62	292	
		HIGH	55.5	60	59	318	61.7	70	66	330	57.7	70	62	320	63.9	80	69	332	
48HC**24 produced on or after May 16, 2016	208/230-3-60	STD	35.5	45	37	204	40.3	50	43	212	37.2	45	39	206	42	50	45	214	
		MED	37.5	45	40	202	42.3	50	45	210	39.2	50	42	204	44.0	50	47	212	
	460-3-60	HIGH	39.4	50	42	229	44.2	50	47	237	41.1	50	44	231	45.9	50	48	239	
		STD-High Efficiency	86.6	100	91	574	98.4	125	105	594	91.4	100	97	579	103.2	125	111	589	
48HC**24 produced on or after May 16, 2016	208/230-3-60	MED-High Efficiency	86.6	100	91	574	98.4	125	105	594	91.4	100	97	579	103.2	125	111	589	
		HIGH-High Efficiency	98.0	125	105	653	109.8	125	118	673	102.8	125	110	668	114.6	125	124	678	
	460-3-60	STD-High Efficiency	45.3	50	48	310	51.5	60	55	322	47.5	60	50	312	53.7	60	58	324	
		MED-High Efficiency	45.3	50	48	310	51.5	60	55	322	47.5	60	50	312	53.7	60	58	324	
	575-3-60	HIGH-High Efficiency	51.0	60	54	350	57.2	70	62	362	53.2	60	57	352	59.4	70	64	364	
		STD-High Efficiency	33.4	40	35	232	38.2	45	41	240	35.1	45	37	234	39.9	50	43	242	
575-3-60	MED-High Efficiency	35.4	45	37	230	40.2	50	43	238	37.1	45	39	232	41.9	50	45	240		
	HIGH-High Efficiency	37.3	45	40	257	42.1	50	45	265	38.0	50	42	259	43.8	50	47	267		

See: "Legend and Notes for Tables 26 – 31" on page 59.

ELECTRICAL INFORMATION (cont.)

Table 29 - UNIT WIRE SIZING DATA WITH FACTORY-INSTALLED HACR BREAKER - SINGLE-SPEED INDOOR FAN MOTOR (cont.)

UNIT	NOM. V-Ph-Hz	IFM TYPE	NO C.O. or UNPWR C.O.												w/ PWRD C.O.						
			NO PE.						w/ P.E. (pwrd fr/ unit)						NO PE.			w/ P.E. (pwrd fr/ unit)			
			MCA	HACR BRKR	FLA	DISC. SIZE	LRA	MCA	HACR BRKR	FLA	DISC. SIZE	LRA	MCA	HACR BRKR	FLA	DISC. SIZE	LRA	MCA	HACR BRKR	FLA	DISC. SIZE
48HC**28 Units produced on or prior to May 15, 2016	208/230-3-60	STD	116.0/116.0	150/150	120/119	590	127.8/127.8	133/132	610	120.8/120.8	150/150	125/124	595	132.6/132.6	139/138	615	132.6/132.6	175/175	139/138	615	
		MED	119.5	150	124	586	131.3	137	606	124.3	150	129	591	136.1	143	611	136.1	175	143	611	
		HIGH	130.9	175	137	665	142.7	150	685	135.7	175	142	670	147.5	156	680	147.5	175	156	680	
	460-3-60	STD	53	60	56	306	59.2	70	63	318	55.2	60	58	308	61.4	65	320	55.2	70	65	320
		MED	55.2	60	58	304	61.4	70	65	318	57.4	60	61	306	63.6	68	318	63.6	80	68	318
		HIGH	60.9	70	65	344	67.1	80	72	356	63.1	80	67	346	69.3	74	358	69.3	80	74	358
	575-3-60	STD	40.4	50	42	228	45.2	50	48	236	42.1	50	44	230	46.9	50	238	46.9	60	50	238
		MED	42.4	50	45	226	47.2	60	50	234	44.1	50	46	228	48.9	52	236	48.9	60	52	236
		HIGH	44.3	50	47	253	49.1	60	52	261	46	60	49	255	50.8	54	263	50.8	60	54	263
48HC**28 1 Units produced on or after May 16, 2016	208/230-3-60	STD	116.6/116.6	150/150	120/119	591	128.4/128.4	134/133	611	121.4/121.4	150/150	126/125	596	133.2/133.2	139/138	616	133.2/133.2	175/175	139/138	616	
		MED-High Efficiency	120.1	150	124	587	131.9	138	607	124.9	150	130	592	136.7	143	612	136.7	175	143	612	
		HIGH-High Efficiency	131.5	175	137	666	143.3	151	686	136.3	175	143	671	148.1	157	681	148.1	175	157	681	
	460-3-60	STD	51.1	60	53	321	57.3	70	60	333	53.3	60	56	323	59.5	63	335	59.5	70	63	335
		MED-High Efficiency	53.3	60	56	319	59.5	70	63	331	55.5	70	58	321	61.7	66	333	61.7	80	66	333
		HIGH-High Efficiency	59.0	70	62	359	65.2	80	70	371	61.2	70	65	361	67.4	72	373	67.4	80	72	373
	575-3-60	STD	40.5	50	42	256	45.3	50	48	264	42.2	50	44	258	47.0	50	266	47.0	60	50	266
		MED-High Efficiency	42.5	50	45	254	47.3	60	50	262	44.2	50	47	256	49.0	52	264	49.0	60	52	264
		HIGH-High Efficiency	44.4	50	47	281	49.2	60	52	289	46.1	60	49	283	50.9	54	291	50.9	60	54	291

1 - STD static is not available on 48HC**28 horizontal.

See: "Legend and Notes for Tables 26 - 31" on page 59.

ELECTRICAL INFORMATION (cont.)

Table 30 – UNIT WIRE/FUSE OR HACR BREAKER SIZING DATA - 2-SPEED INDOOR FAN MOTOR

UNIT	NOM. V-Ph-Hz	IFM TYPE	NO C.O. or UNPWR C.O.						w/ PWRD C.O.									
			NO PE.			w/ PE. (pwrdr fr/ unit)			NO PE.			w/ PE. (pwrdr fr/ unit)						
			MCA	MAX FUSE or HACR BRKR	DISC. SIZE FLA LRA	MCA	MAX FUSE or HACR BRKR	DISC. SIZE FLA LRA	MCA	MAX FUSE or HACR BRKR	DISC. SIZE FLA LRA	MCA	MAX FUSE or HACR BRKR	DISC. SIZE FLA LRA				
48HC**17	208/230-3-60	STD	69.4/68.6	90/90	73/72	390	81.2/80.4	100/100	86/85	410	74.2/73.4	90/90	78/77	395	86.0/85.2	100/100	92/91	415
		MED	71.6/70.6	90/90	75/74	414	83.4/82.4	100/100	89/88	434	76.4/75.4	100/100	81/79	419	88.2/87.2	100/100	94/93	439
		HIGH	74.4/73.5	90/90	78/77	425	86.2/85.3	100/100	92/91	445	79.2/78.3	100/100	84/83	430	91.0/90.1	100/100	97/96	450
	480-3-60	STD	35.3	45	37	233	41.5	50	44	245	37.5	50	39	235	43.7	50	47	247
		MED	36.4	45	38	245	42.6	50	45	257	38.6	50	41	247	44.8	50	48	259
		HIGH	37.9	50	40	250	44.1	50	47	262	40.1	50	42	252	46.3	50	50	264
	575-3-60	STD	27.9	35	29	184	32.7	40	35	192	29.6	35	31	186	34.4	40	37	194
		MED	27.9	35	29	184	32.7	40	35	192	29.6	35	31	186	34.4	40	37	194
		HIGH	29.6	35	31	198	34.4	40	37	206	31.3	40	33	200	36.1	45	39	208
	48HC**20	208/230-3-60	STD	76.3/75.3	100/100	80/79	444	88.1/87.1	100/100	93/92	464	81.1/80.1	100/100	85/84	449	92.9/91.9	100/100	99/98
MED			79.1/78.2	100/100	83/82	455	90.9/90.0	100/100	97/96	475	83.9/83.0	100/100	89/88	460	95.7/94.8	110/110	102/101	480
HIGH			82.6	100	87	451	94.4	110	101	471	87.4	100	93	456	99.2	125	106	476
480-3-60		STD	36.7	45	39	247	42.9	50	46	259	38.9	50	41	249	45.1	50	48	261
		MED	38.2	50	40	252	44.4	50	47	264	40.4	50	43	254	46.6	50	50	266
		HIGH	40.4	50	43	250	46.6	50	50	262	42.6	50	45	252	48.8	60	52	264
575-3-60		STD	27.9	35	29	186	32.7	40	35	194	29.6	35	31	188	34.4	40	37	196
		MED	29.6	35	31	200	34.4	40	37	208	31.3	40	33	202	36.1	45	39	210
		HIGH	31.0	40	33	198	35.8	45	38	206	32.7	40	35	200	37.5	45	40	208
48HC**24 Units produced on or prior to May 15, 2016		208/230-3-60	STD	87.3/86.4	100/100	92/91	550	99.1/98.2	125/125	105/104	570	92.1/91.2	100/100	97/96	555	103.9/103.0	125/125	111/110
	MED		90.8	100	96	546	102.6	125	109	566	95.6	125	101	551	107.4	125	115	571
	HIGH		102.2	125	109	625	114.0	125	122	645	107.0	125	114	630	118.8	150	128	650
	480-3-60	STD	47.6	60	50	280	53.8	60	57	292	49.8	60	52	282	56.0	70	60	294
		MED	49.8	60	52	278	56.0	70	60	290	52.0	60	55	280	58.2	70	62	292
		HIGH	55.5	60	59	318	61.7	70	66	330	57.7	70	62	320	63.9	80	69	332
	575-3-60	STD	36.1	45	38	204	40.9	50	43	212	37.8	45	40	206	42.6	50	45	214
		MED	37.5	45	40	202	42.3	50	45	210	39.2	50	42	204	44.0	50	47	212
		HIGH	39.4	50	42	229	44.2	50	47	237	41.1	50	44	231	45.9	50	49	239
	48HC**24 Units produced on or after May 16, 2016	208/230-3-60	STD	83.1/82.2	100/100	87/86	578	94.9/94.0	110/110	101/100	598	87.9/87.0	100/100	93/92	583	99.7/98.8	125/125	106/105
MED			86.6	100	91	574	98.4	125	105	594	91.4	100	97	579	103.2	125	111	599
HIGH			98.0	125	105	653	109.8	125	118	673	102.8	125	110	668	114.6	125	124	678
480-3-60		STD	43.1	50	45	312	49.3	60	52	324	45.3	50	48	314	51.5	60	55	326
		MED	45.3	50	48	310	51.5	60	55	322	47.5	60	50	312	53.7	60	58	324
		HIGH	51.0	60	54	350	57.2	70	62	362	53.2	60	57	352	59.4	70	64	364
575-3-60		STD	34.0	45	36	232	38.8	50	41	240	35.7	45	38	234	40.5	50	43	242
		MED	35.4	45	37	230	40.2	50	43	238	37.1	45	39	232	41.9	50	45	240
		HIGH	37.3	45	40	257	42.1	50	45	265	39.0	50	42	259	43.8	50	47	267

See: "Legend and Notes for Tables 26 – 31" on page 59.

ELECTRICAL INFORMATION (cont.)

Table 30 - UNIT WIRE/FUSE OR HACR BREAKER SIZING DATA - 2-SPEED INDOOR FAN MOTOR (cont.)

UNIT	NOM. V-Ph-Hz	IFM TYPE	NO C.O. or UNPWR C.O.						w/ PWRD C.O.										
			NO PE.			w/ P.E. (pwrd fr/ unit)			NO PE.			w/ P.E. (pwrd fr/ unit)							
			MCA	MAX FUSE or HACR BRKR	DISC. SIZE FLA LRA	MCA	MAX FUSE or HACR BRKR	DISC. SIZE FLA LRA	MCA	MAX FUSE or HACR BRKR	DISC. SIZE FLA LRA	MCA	MAX FUSE or HACR BRKR	DISC. SIZE FLA LRA					
48HC**28 Units produced on or prior to May 15, 2016	208/230-3-60	STD	116.0/115.1	150/150	120/119	590	127.8/126.9	175/175	133/132	610	120.8/119.9	150/150	125/124	595	132.6/131.7	175/175	139/138	615	
		MED	119.5	150	124	586	131.3	175	137	606	124.3	150	129	591	136.1	175	143	611	
		HIGH	130.9	175	137	665	142.7	175	150	685	135.7	175	142	670	147.5	175	156	690	
	460-3-60	STD	53.0	60	56	306	59.2	70	63	318	55.2	60	58	308	61.4	70	66	320	
		MED	55.2	60	58	304	61.4	70	65	316	57.4	70	61	306	63.6	80	68	318	
		HIGH	60.9	70	65	344	67.1	80	72	356	63.1	80	67	346	69.3	80	74	358	
	575-3-60	STD	41.0	50	43	228	45.8	60	48	236	42.7	50	45	230	47.5	60	50	238	
		MED	42.4	50	45	226	47.2	60	50	234	44.1	50	46	228	48.9	60	52	236	
		HIGH	44.3	50	47	253	49.1	60	52	261	46.0	60	49	255	50.8	60	54	263	
	48HC**28 1 Units produced on or after May 16, 2016	208/230-3-60	STD	116.6/115.7	150/150	120/119	591	128.4/127.5	175/175	134/133	611	121.4/120.5	150/150	126/125	596	133.2/132.3	175/175	139/138	616
			MED	120.1	150	124	587	131.9	175	138	607	124.9	150	130	592	136.7	175	143	612
			HIGH	131.5	175	137	666	143.3	175	151	686	136.3	175	143	671	148.1	175	157	691
460-3-60		STD	51.1	60	53	321	57.3	70	60	333	53.3	60	56	323	59.5	70	63	335	
		MED	53.3	60	56	319	59.5	70	63	331	55.5	70	58	321	61.7	80	66	333	
		HIGH	59.0	70	62	359	65.2	80	70	371	61.2	70	65	361	67.4	80	72	373	
575-3-60		STD	41.1	50	43	256	45.9	60	49	264	42.8	50	45	258	47.6	60	50	266	
		MED	42.5	50	45	254	47.3	60	50	262	44.2	50	47	256	49.0	60	52	264	
		HIGH	44.4	50	47	281	49.2	60	52	289	46.1	60	49	283	50.9	60	54	291	

1 - STD static is not available on 48HC**28 horizontal.

See: "Legend and Notes for Tables 26 - 31" on page 59.

ELECTRICAL INFORMATION (cont.)

Table 31 – UNIT WIRE SIZING DATA WITH FACTORY-INSTALLED HACR BREAKER - 2-SPEED INDOOR FAN OPTION

UNIT	NOM. V-Ph-Hz	IFM TYPE	NO C.O. or UNPWR C.O.						w/ PWRD C.O.									
			NO PE.			w/ PE. (pwrdr fr/ unit)			NO PE.			w/ PE. (pwrdr fr/ unit)						
			MCA	MAX FUSE or HACR BRKR	DISC. SIZE FLA LRA	MCA	MAX FUSE or HACR BRKR	DISC. SIZE FLA LRA	MCA	MAX FUSE or HACR BRKR	DISC. SIZE FLA LRA	MCA	MAX FUSE or HACR BRKR	DISC. SIZE FLA LRA				
48HC**17	208/230-3-60	STD	69.4/69.4	90/90	73/72	390	81.2/81.2	100/100	86/85	410	74.2/74.2	90/90	78/77	395	86.0/86.0	100/100	92/91	415
		MED	71.6/71.6	90/90	75/74	414	83.4/83.4	100/100	89/88	434	76.4/76.4	100/100	81/79	419	88.2/88.2	100/100	94/93	439
		HIGH	74.4/74.4	90/90	78/77	425	86.2/86.2	100/100	92/91	445	79.2/79.2	100/100	84/83	430	91.0/91.0	100/100	97/96	450
	480-3-60	STD	35.3	45	37	233	41.5	50	44	245	37.5	50	39	235	43.7	50	47	247
		MED	36.4	45	38	245	42.6	50	45	257	38.6	50	41	247	44.8	50	48	259
		HIGH	37.9	50	40	250	44.1	50	47	262	40.1	50	42	252	46.3	50	50	264
		STD	27.9	35	29	184	32.7	40	35	192	29.6	35	31	186	34.4	40	37	194
48HC**20	208/230-3-60	MED	27.9	35	29	184	32.7	40	35	192	29.6	35	31	186	34.4	40	37	194
		HIGH	29.6	35	31	198	34.4	40	37	206	31.3	40	33	200	36.1	45	39	208
		STD	76.3/76.3	100/100	80/79	444	88.1/88.1	100/100	93/92	464	81.1/81.1	100/100	85/84	449	92.9/92.9	100/100	99/98	469
	460-3-60	MED	79.1/79.1	100/100	83/82	455	90.9/90.9	100/100	97/96	475	83.9/83.9	100/100	89/88	460	95.7/95.7	110/110	102/101	480
		HIGH	82.6	100	87	451	94.4	110	101	471	87.4	100	93	456	99.2	125	106	476
		STD	36.7	45	39	247	42.9	50	46	259	38.9	50	41	249	45.1	50	48	261
		MED	38.2	50	40	252	44.4	50	47	264	40.4	50	43	254	46.6	50	50	266
48HC**24 produced on or prior to May 15, 2016	208/230-3-60	HIGH	40.4	50	43	250	46.6	50	50	262	42.6	50	45	252	48.8	60	52	264
		STD	27.9	35	29	186	32.7	40	35	194	29.6	35	31	188	34.4	40	37	196
		MED	29.6	35	31	200	34.4	40	37	208	31.3	40	33	202	36.1	45	39	210
	460-3-60	HIGH	31.0	40	33	198	35.8	45	38	206	32.7	40	35	200	37.5	45	40	208
		STD	87.3/87.3	100/100	92/91	550	99.1/99.1	125/125	105/104	570	92.1/92.1	100/100	97/96	565	103.9/103.9	125/125	111/110	575
		MED	90.8	100	96	546	102.6	125	109	566	95.6	125	101	551	107.4	125	115	571
		HIGH	102.2	125	109	625	114.0	125	122	645	107.0	125	114	630	118.8	150	128	650
48HC**24 produced on or after May 16, 2016	460-3-60	STD	47.6	60	50	280	53.8	60	57	292	49.8	60	52	282	56	70	60	294
		MED	49.8	60	52	278	56.0	70	60	290	52.0	60	55	280	58.2	70	62	292
		HIGH	55.5	60	59	318	61.7	70	66	330	57.7	70	62	320	63.9	80	69	332
	575-3-60	STD	36.1	45	38	204	40.9	50	43	212	37.8	45	40	206	42.6	50	45	214
		MED	37.5	45	40	202	42.3	50	45	210	39.2	50	42	204	44.0	50	47	212
		HIGH	39.4	50	42	229	44.2	50	47	237	41.1	50	44	231	45.9	50	49	239
		STD	83.1/83.1	100/100	87/86	578	94.9/94.9	110/110	101/100	598	87.9/87.9	100/100	93/92	583	99.7/99.7	125/125	106/105	603
48HC**24 Units produced on or after May 16, 2016	208/230-3-60	MED	86.6	100	91	574	98.4	125	105	594	91.4	100	97	579	103.2	125	111	599
		HIGH	98.0	125	105	653	109.8	125	118	673	102.8	125	110	668	114.6	125	124	678
		STD	43.1	50	45	312	49.3	60	52	324	45.3	60	48	314	51.5	60	55	326
	460-3-60	MED	45.3	50	48	310	51.5	60	55	322	47.5	60	50	312	53.7	60	58	324
		HIGH	51.0	60	54	350	57.2	70	62	362	53.2	60	57	352	59.4	70	64	364
		STD	34.0	45	36	232	38.8	50	41	240	35.7	45	38	234	40.5	50	43	242
		MED	35.4	45	37	230	40.2	50	43	238	37.1	45	39	232	41.9	50	45	240
575-3-60	HIGH	37.3	45	40	257	42.1	50	45	265	39.0	50	42	259	43.8	50	47	267	

See: "Legend and Notes for Tables 26 – 31" on page 59.

ELECTRICAL INFORMATION (cont.)

Table 31 - UNIT WIRE SIZING DATA WITH FACTORY-INSTALLED HACR BREAKER - 2-SPEED INDOOR FAN OPTION (cont.)

UNIT	NOM. V-Ph-Hz	IFM TYPE	NO C.O. or UNPWR C.O.						w/ PWRD C.O.									
			NO PE.			w/ P.E. (pwrdr fr/ unit)			NO PE.			w/ P.E. (pwrdr fr/ unit)						
			MCA	MAX FUSE or HACR BRKR	DISC. SIZE FLA LRA	MCA	MAX FUSE or HACR BRKR	DISC. SIZE FLA LRA	MCA	MAX FUSE or HACR BRKR	DISC. SIZE FLA LRA	MCA	MAX FUSE or HACR BRKR	DISC. SIZE FLA LRA				
48HC**28 Units produced on or prior to May 15, 2016	208/230-3-60	STD	116.0/116.0	150/150	120/119	590	127.8/127.8	175/175	133/132	610	120.8/120.8	150/150	125/124	595	132.6/132.6	175/175	139/138	615
		MED	119.5	150	124	586	131.3	175	137	606	124.3	150	129	591	136.1	175	143	611
	460-3-60	HIGH	130.9	175	137	665	142.7	175	150	685	135.7	175	142	670	147.5	175	156	690
		STD	53	60	56	306	59.2	70	63	318	55.2	60	58	308	61.4	70	66	320
	575-3-60	MED	55.2	60	58	304	61.4	70	65	316	57.4	70	61	306	63.6	80	68	318
		HIGH	60.9	70	65	344	67.1	80	72	356	63.1	80	67	346	69.3	80	74	358
48HC**28 1 Units produced on or after May 16, 2016	208/230-3-60	STD	116.6/116.6	150/150	120/119	591	128.4/128.4	175/175	134/133	611	121.4/121.4	150/150	126/125	596	133.2/133.2	175/175	139/138	616
		MED	120.1	150	124	587	131.9	175	138	607	124.9	150	130	592	136.7	175	143	612
	460-3-60	HIGH	131.5	175	137	666	143.3	175	151	686	136.3	175	143	671	148.1	175	157	691
		STD	51.1	60	53	321	57.3	70	60	333	53.3	60	56	323	59.5	70	63	335
	575-3-60	MED	53.3	60	56	319	59.5	70	63	331	55.5	70	58	321	61.7	80	66	333
		HIGH	59.0	70	62	359	65.2	80	70	371	61.2	70	65	361	67.4	80	72	373
48HC**28 1 Units produced on or after May 16, 2016	575-3-60	STD	41.1	50	43	256	45.9	60	49	264	42.8	50	45	258	47.6	60	50	266
		MED	42.5	50	45	254	47.3	60	50	262	44.2	50	47	256	49.0	60	52	264
		HIGH	44.4	50	47	281	49.2	60	52	289	46.1	60	49	283	50.9	60	54	291

1 - STD static is not available on 48HC**28 horizontal.

See: "Legend and Notes for Tables 26 - 31" on page 59.

Legend and Notes for Tables 26 - 31

LEGEND:	
BRKR	— Circuit breaker
C.O.	— Convenience outlet
DISC	— Disconnect
EFF	— Efficiency
FLA	— Full load amps
LRA	— Locked rotor amps
MCA	— Minimum circuit amps
PE	— Power exhaust
Pwrld fr/ unit	— Powered from unit
PWRD C.O.	— Powered convenience outlet
RLA	— Rated load amps
UNPWR C.O.	— Unpowered convenience outlet



NOTES:

- In compliance with NEC requirements for multimotor and combination load equipment (refer to NEC Articles 430 and 440), the overcurrent protective device for the unit shall be fuse or HACR breaker. Canadian units may be fuse or circuit breaker.

- For 208/230 v units, where one value is shown it is the same for either 208 or 230 volts.

- Unbalanced 3-Phase Supply Voltage**
Never operate a motor where a phase imbalance in supply voltage is greater than 2%. Use the following formula to determine the percentage of voltage imbalance.

$$\% \text{ Voltage Imbalance} = 100 \times \frac{\text{max voltage deviation from average voltage}}{\text{average voltage}}$$

Example: Supply voltage is 230-3-60



AB = 224 v
BC = 231 v
AC = 226 v

$$\text{Average Voltage} = \frac{(224 + 231 + 226)}{3} = \frac{681}{3} = 227$$

Determine maximum deviation from average voltage.

$$(AB) 227 - 224 = 3 \text{ v}$$

$$(BC) 231 - 227 = 4 \text{ v}$$

$$(AC) 227 - 226 = 1 \text{ v}$$

Maximum deviation is 4 v.

Determine percent of voltage imbalance.

$$\% \text{ Voltage Imbalance} = 100 \times \frac{4}{227} = 1.76\%$$

This amount of phase imbalance is satisfactory as it is below the maximum allowable 2%.
IMPORTANT: If the supply voltage phase imbalance is more than 2%, contact your local electric utility company immediately.

NOTE: The 2 speed motors are the same efficiency level as the single speed motors.

TYPICAL WIRING DIAGRAMS

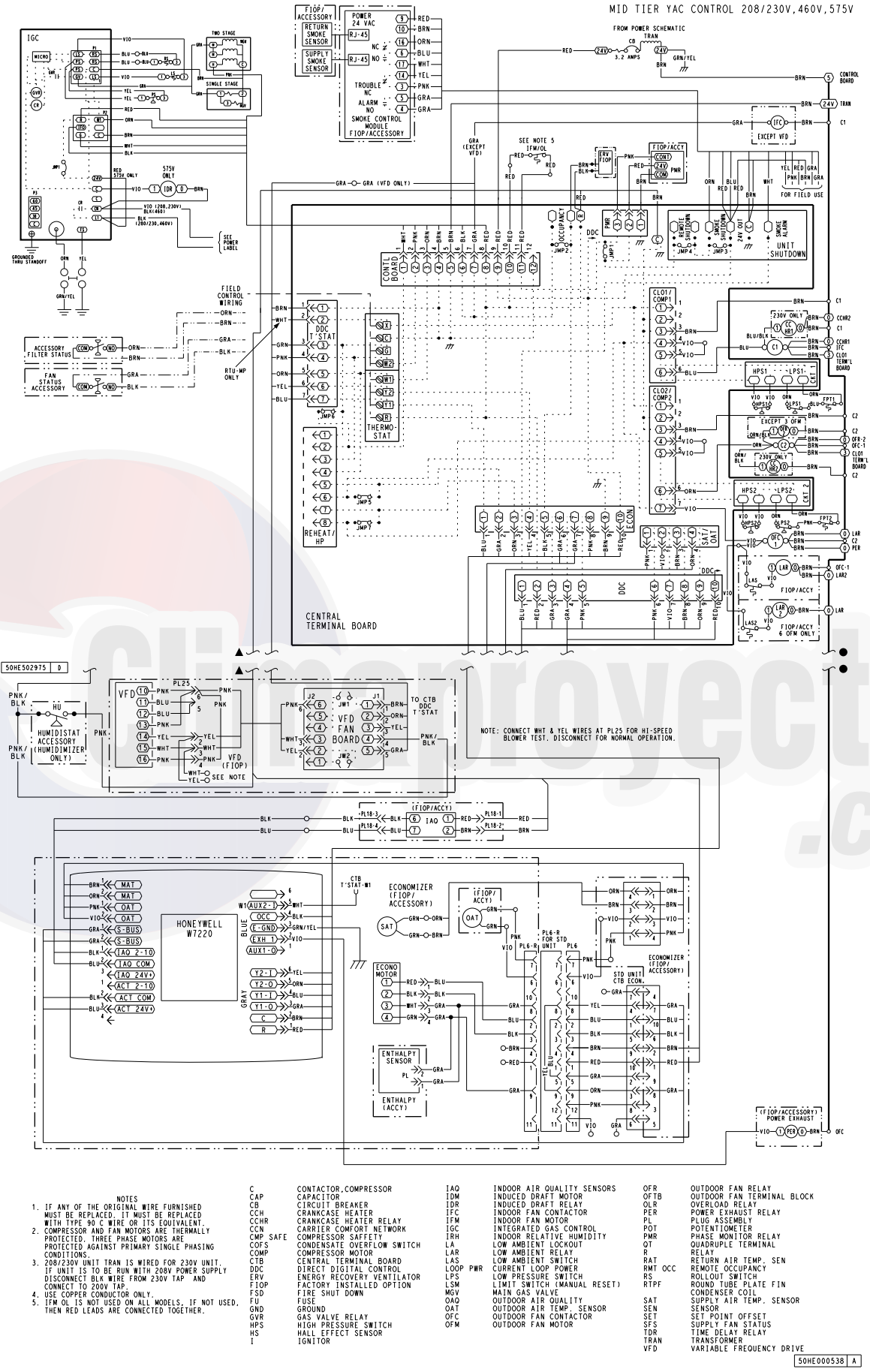

- NOTES**
1. IF ANY OF THE ORIGINAL WIRE FURNISHED MUST BE REPLACED, IT MUST BE REPLACED WITH TYPE 90 C WIRE OR ITS EQUIVALENT.
 2. COMPRESSOR AND FAN MOTORS ARE THERMALLY PROTECTED. THREE PHASE MOTORS ARE PROTECTED AGAINST PRIMARY SINGLE PHASING CONDITIONS.
 3. 208/230V UNIT TRAIL IS WIRED FOR 230V SUPPLY. IF UNIT IS TO BE RUN WITH 208V POWER SUPPLY DISCONNECT BLK WIRE FROM 230V TAP AND CONNECT TO 208V TAP.
 4. USE COPPER CONDUCTOR ONLY.
 5. IFM OL IS NOT USED ON ALL MODELS. IF NOT USED, THEN RED LEADS ARE CONNECTED TOGETHER.

C	CONTACTOR, COMPRESSOR	IAO	INDOOR AIR QUALITY SENSORS	OFR	OUTDOOR FAN RELAY
CAP	CAPACITOR	IDM	INDUCED DRAFT MOTOR	OTFB	OUTDOOR FAN TERMINAL BLOCK
CB	CIRCUIT BREAKER	IDR	INDUCED DRAFT RELAY	OLR	OVERLOAD RELAY
CH	CRANKCASE HEATER	IFC	INDOOR FAN CONTACTOR	PER	POWER EXHAUST RELAY
CCH	CRANKCASE HEATER RELAY	IFM	INDOOR FAN MOTOR	PL	PLUG ASSEMBLY
CCN	CARRIER COMFORT NETWORK	IGC	INTEGRATED GAS CONTROL	POT	POTENTIOMETER
CMP	COMPRESSOR SAFETY	IRH	INDOOR RELATIVE HUMIDITY	PWR	PHASE MONITOR RELAY
COFS	CONDENSATE OVERFLOW SWITCH	LA	LOW AMBIENT LOCKOUT	QTR	QUADRUPLE TERMINAL
COMP	COMPRESSOR MOTOR	LAR	LOW AMBIENT RELAY	R	RELAY
CTB	CENTRAL TERMINAL BOARD	LAS	LOW AMBIENT SWITCH	RAT	RETURN AIR TEMP. SEN
DDC	DIRECT DIGITAL CONTROL	LSP	LOW PRESSURE SWITCH	RMT	REMOTE OCCUPANCY
ERV	ENERGY RECOVERY VENTILATOR	LWS	LIMIT SWITCH (MANUAL RESET)	RS	ROLLOUT SWITCH
FAC	FACTORY INSTALLED OPTION	LSM	LOW SMOKE	RTP	ROUND TUBE PLATE FIN
FSD	FIRE SHUT DOWN	MGV	MAIN GAS VALVE	SCN	CONDENSER COIL
FU	FUSE	OAO	OUTDOOR AIR QUALITY	SAT	SUPPLY AIR TEMP. SENSOR
GND	GROUND	OAT	OUTDOOR AIR TEMP. SENSOR	SEN	SENSOR
GVR	GAS VALVE RELAY	OFC	OUTDOOR FAN CONTACTOR	SET	SET POINT OFFSET
HPS	HIGH PRESSURE SWITCH	OFM	OUTDOOR FAN MOTOR	SFS	SUPPLY FAN STATUS
I	IGNITOR			TDR	TIME DELAY RELAY
				TRN	TRANSFORMER
				VFD	VARIABLE FREQUENCY DRIVE

Fig. 19 - Electro-mechanical Control Wiring Diagram 48HC 17-24

TYPICAL WIRING DIAGRAMS (cont.)

MID TIER YAC W/DEHUMIDIFICATION CONTROL 208/230V, 460V, 575V

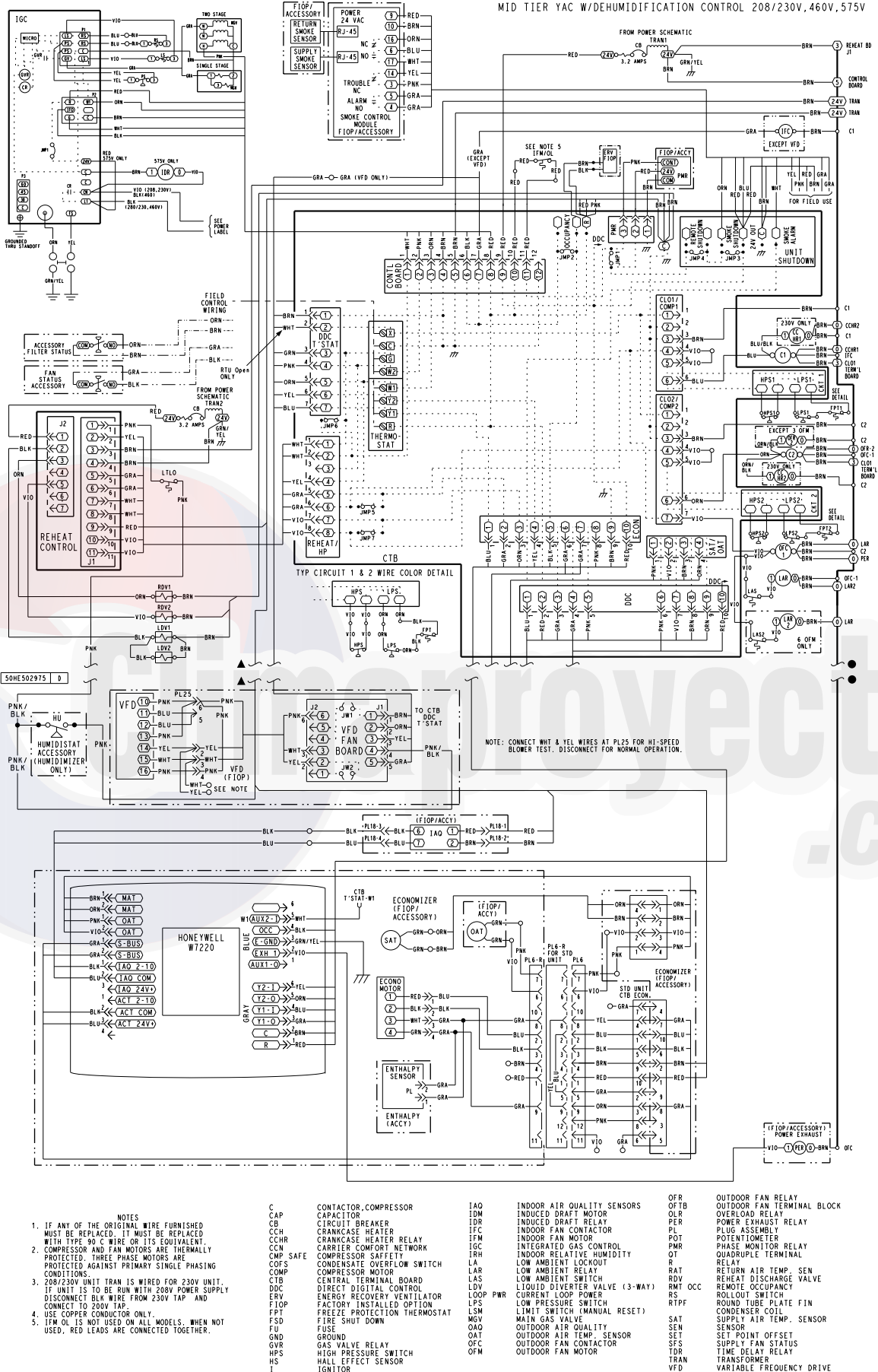

Fig. 20 - Electro-mechanical Control Wiring Diagram 48HC 17-24 with Optional Humidi-MiZer® System

TYPICAL WIRING DIAGRAMS (cont.)

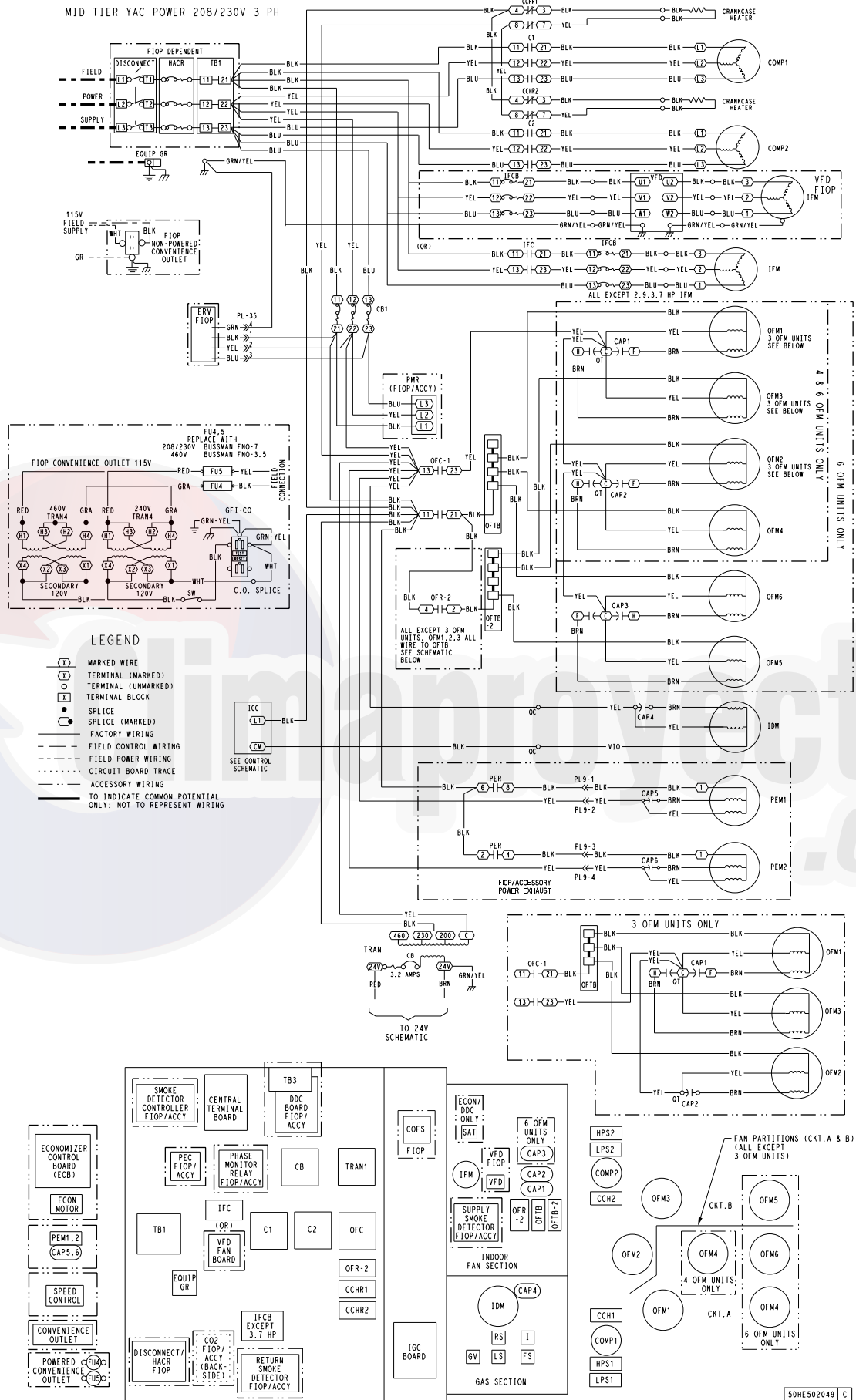

Fig. 21 - Typical Power Wiring Diagram, 48HC 17-24 208/230V shown

TYPICAL WIRING DIAGRAMS (cont.)

MID TIER YAC W/DEHUMIDIFICATION POWER 208/230V 3 PH

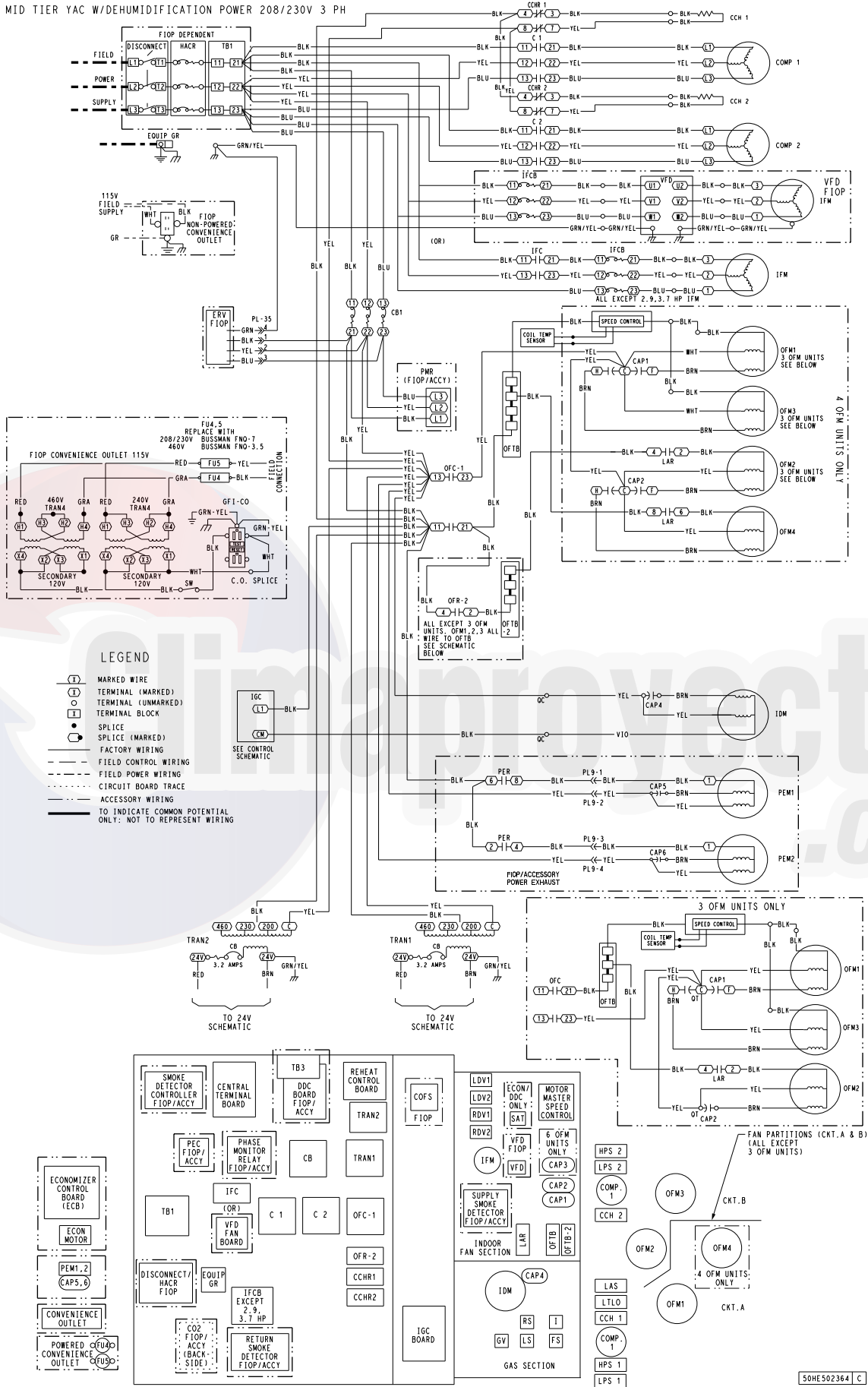

Fig. 22 - Typical Power Wiring Diagram for unit with Optional Humidi-MiZer® System, 48HC 17-24 208/230V shown

SEQUENCE OF OPERATION

General

The sequence below describes the sequence of operation for an electro-mechanical unit with and without a factory-installed EconoMi\$er IV and X (called “economizer” in this sequence). For information regarding a direct digital controller, see the start-up, operations, and troubleshooting manual for the applicable controller.

Electro-mechanical units with no economizer

Cooling (Single speed indoor fan motor) —

When the thermostat calls for cooling, terminals G and Y1 are energized. As a result, the indoor-fan contactor (IFC) and the compressor contactor (C1) are energized, causing the indoor-fan motor (IFM), compressor #1, and outdoor fan to start. If the unit has 2 stages of cooling, the thermostat will additionally energize Y2. The Y2 signal will energize compressor contactor #2 (C2), causing compressor #2 to start. Regardless of the number of stages, the outdoor-fan motor runs continuously while unit is cooling.

Cooling (2-speed indoor fan motor) —

Per ASHRAE 90.1-2013 standard, during the first stage of cooling operation the VFD will adjust the fan motor to provide 66% of the total cfm established for the unit. When a call for the second stage of cooling is required, the VFD will allow the total cfm for the unit established (100%).

Heating —

NOTE: WeatherMaster® (48HC) units have 2 stages of gas heat.

When the thermostat calls for heating, power is sent to W on the Integrated Gas Controller (IGC) board. An LED (light-emitting diode) on the IGC board turns on and remains on during normal operation. A check is made to ensure that the rollout switch and limit switch are closed. If the check was successful, the induced-draft motor is energized, and when its speed is satisfactory, as proven by the flue gas pressure switch, the ignition activation period begins. The burners will ignite within 5 seconds. If the burners do not light, there is a 22-second delay before another 5-second attempt. This sequence is repeated for 15 minutes or until the burners light. If, after the 15 minutes, the burners still have not lit, heating is locked out. To reset the control, break 24-v power to the thermostat.

When ignition occurs, the IGC board will continue to monitor the condition of the rollout switch, the limit switches, the flue gas pressure switch, as well as the flame sensor. Forty-five seconds after ignition occurs, assuming the unit is controlled through a room thermostat set for fan auto, the indoor-fan motor will energize (and the outdoor-air dampers will open to their minimum position). If, for some reason, the over-temperature limit opens prior to the start of the indoor fan blower, the unit will shorten the 45-second delay to 5 seconds less than

the time from initiation of heat to when the limit tripped. Gas will not be interrupted to the burners and heating will continue. Once the fan-on delay has been modified, it will not change back to 45 seconds until power is reset to the control.

On units with 2 stages of heat, when additional heat is required, W2 closes and initiates power to the second stage of the main gas valve. When the thermostat is satisfied, W1 and W2 open and the gas valve closes, interrupting the flow of gas to the main burners.

If the call for W1 lasted less than 1 minute, the heating cycle will not terminate until 1 minute after W1 became active. If the unit is controlled through a room thermostat set for fan auto, the indoor-fan motor will continue to operate for an additional 45 seconds then stop. If the over-temperature limit opens after the indoor motor is stopped, but within 10 minutes of W1 becoming inactive, on the next cycle the time will be extended by 15 seconds. The maximum delay is 3 minutes. Once modified, the fan off delay will not change back to 45 seconds unless power is reset to the control. A LED indicator is provided on the IGC to monitor operation.

Electro-mechanical units with an economizer

Cooling —

When free cooling is not available, the compressors will be controlled by the zone thermostat. When free cooling is available, the outdoor-air damper is modulated by the EconoMi\$er IV and X control to provide a 50°F (10°C) to 55°F (13°C) mixed-air temperature into the zone. As the mixed air temperature fluctuates above 55°F (13°C) or below 50°F (10°C) dampers will be modulated (open or close) to bring the mixed-air temperature back within control. If mechanical cooling is utilized with free cooling, the outdoor-air damper will maintain its current position at the time the compressor is started. If the increase in cooling capacity causes the mixed-air temperature to drop below 45°F (7°C), then the outdoor-air damper position will be decreased to the minimum position. If the mixed-air temperature continues to fall, the outdoor-air damper will close. Control returns to normal once the mixed-air temperature rises above 48°F (9°C). The power exhaust fans will be energized and de-energized, if installed, as the outdoor-air damper opens and closes.

If field-installed accessory CO₂ sensors are connected to the EconoMi\$er IV and X control, a demand controlled ventilation strategy will begin to operate. As the CO₂ level in the zone increases above the CO₂ setpoint, the minimum position of the damper will be increased proportionally. As the CO₂ level decreases because of the increase in fresh air, the outdoor-air damper will be proportionally closed. For EconoMi\$er IV and X operation, there must be a thermostat call for the fan (G). If the unit is occupied and the fan is on, the damper will operate at minimum position. Otherwise, the damper will be closed.

SEQUENCE OF OPERATION (cont.)

When the EconoMiSer IV and X control is in the occupied mode and a call for cooling exists (Y1 on the thermostat), the control will first check for indoor fan operation. If the fan is not on, then cooling will not be activated. If the fan is on, then the control will open the EconoMiSer IV and damper to the minimum position.

On the initial power to the EconoMiSer IV and X control, it will take the damper up to 2-1/2 minutes before it begins to position itself. After the initial power-up, further changes in damper position can take up to 30 seconds to initiate. Damper movement from full closed to full open (or vice versa) will take between 1-1/2 and 2-1/2 minutes. If free cooling can be used as determined from the appropriate changeover command (switch, dry bulb, enthalpy curve, differential dry bulb, or differential enthalpy), then the control will modulate the dampers open to maintain the mixed-air temperature setpoint at 50°F (10°C) to 55°F (13°C). If there is a further demand for cooling (cooling second stage - Y2 is energized), then the control will bring on compressor stage 1 to maintain the mixed-air temperature setpoint. The EconoMiSer IV and X damper will be open at maximum position. EconoMiSer IV and X operation is limited to a single compressor.

2-Speed Note: When operating in ventilation mode only, the indoor fan motor will automatically adjust to 66% of the total cfm established.

Heating —

The sequence of operation for the heating is the same as an electro-mechanical unit with no economizer. The only difference is how the economizer acts. The economizer will stay at the Economizer Minimum Position while the evaporator fan is operating. The outdoor-air damper is closed when the indoor fan is not operating.

Refer to Service and Maintenance Manual for further details.

Optional Humidi-MiZer® Dehumidification System

Units with the factory equipped Humidi-MiZer option are capable of providing multiple modes of improved dehumidification as a variation of the normal cooling cycle. The Humidi-MiZer option includes additional valves in the liquid line and discharge line of each refrigerant circuit, a small reheat condenser coil downstream of the evaporator, and Motormaster® variable-speed control of some or all outdoor fans. Operation of the revised refrigerant circuit for each mode is described below.

The Humidi-MiZer system provides three sub-modes of operation: Cool, Reheat1, and Reheat2.

Cool mode - provides a normal ratio of Sensible and Latent Cooling effect from the evaporator coil.

Reheat1 - provides increased Latent Cooling while slightly reducing the Sensible Cooling effect.

Reheat2 - provides normal Latent Cooling but with null or minimum Sensible Cooling effect delivered to the space.

The Reheat1 and Reheat2 modes are available when the unit is not in a Heating mode and when the Low Ambient Lockout switch is closed.

RTU Open (Factory Option)

For details on operating 48HC units equipped with the factory-installed RTU Open option refer to *Factory Installed Option RTU Open Multi-Protocol Controller Controls, Start-Up, Operation and Troubleshooting* (Catalog No.: 48-50LHTCQ-01T or later).

SEQUENCE OF OPERATION (cont.)

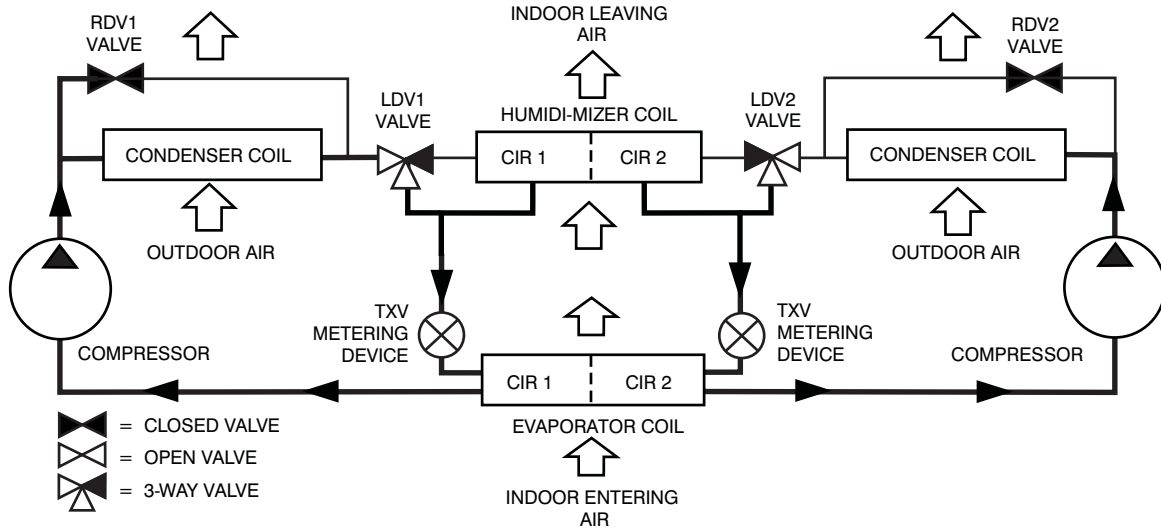

Normal Cooling Mode - Humidi-MiZer® System

C12705

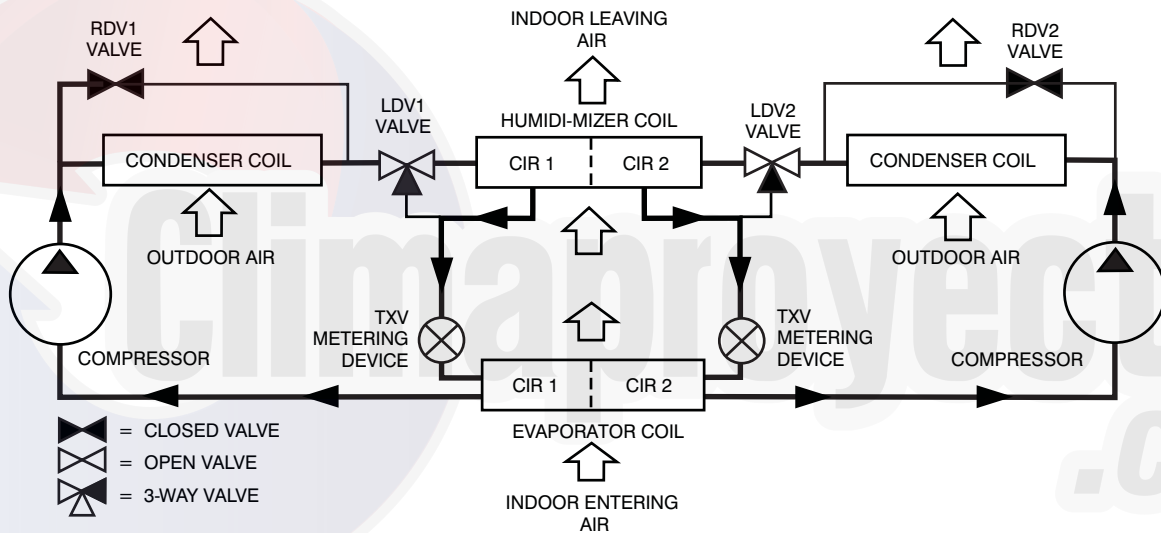

Subcooling Mode (Reheat 1) - Humidi-MiZer System

C12706

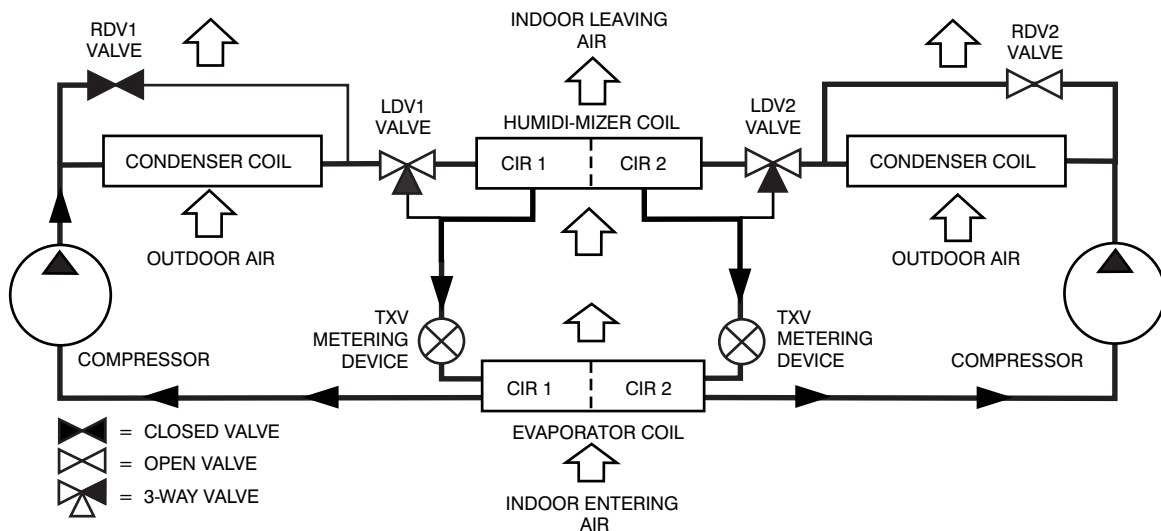

Hot Gas Reheat Mode (Reheat 2) - Humidi-MiZer System

C12707

GUIDE SPECIFICATIONS - 48HC**17-28

Note about this specification:

These specifications are written in “Masterformat” as published by the Construction Specification Institute. Please feel free to copy this specification directly into your building spec.

WeatherMaster® Gas Heat/Electric Cooling Packaged Rooftop HVAC Guide Specifications



Size Range: 15 to 25 Nominal Tons

Section Description

23 06 80 Schedules for Decentralized HVAC Equipment

- 23 06 80.13 Decentralized Unitary HVAC Equipment Schedule
- 23 06 80.13.A. Rooftop unit schedule
 - 1. Schedule is per the project specification requirements.

23 07 16 HVAC Equipment Insulation

- 23 07 16.13 Decentralized, Rooftop Units:
 - 23 07 16.13.A. Evaporator fan compartment:
 - 1. Interior cabinet surfaces shall be insulated with a minimum 1/2-in. thick, minimum 1 1/2 lb density, flexible fiberglass insulation bonded with a phenolic binder, neoprene coated on the air side.
 - 2. Insulation and adhesive shall meet NFPA 90A requirements for flame spread and smoke generation.
 - 3. Unit internal insulation linings shall be resistant to mold growth in accordance with “mold growth and humidity” test in ASTM C1338, G21, and UL 181 or comparable test method. Air stream surfaces shall be evaluated in accordance with the “Erosion Test” in UL 181, as part of ASTM C1071.
 - 23 07 16.13.B. Gas heat compartment:
 - 1. Aluminum foil-faced fiberglass insulation shall be used.
 - 2. Insulation and adhesive shall meet NFPA 90A requirements for flame spread and smoke generation.

23 09 13 Instrumentation and Control Devices for HVAC

- 23 09 13.23 Sensors and Transmitters
 - 23 09 13.23.A. Thermostats
 - 1. Thermostat must
 - a. energize both “W” and “G” when calling for heat.
 - b. have capability to energize 2 different stages of cooling, and 2 different stages of heating.
 - c. include capability for occupancy scheduling.

23 09 23 Direct-digital Control system for HVAC

- 23 09 23.13 Decentralized, Rooftop Units:
 - 23 09 23.13.A. PremierLink™ controller
 - 1. Shall be ASHRAE 62 compliant.
 - 2. Shall accept 18-32 VAC input power.
 - 3. Shall have an operating temperature range from -40°F (-40°C) to 158°F (70°C), 10% - 95% RH (non-condensing).
 - 4. Shall include an integrated economizer controller to support an economizer with 4 to 20 mA actuator input and no microprocessor controller.
 - 5. Controller shall accept the following inputs: space temperature, setpoint adjustment, outdoor air temperature, indoor air quality, outdoor air quality, indoor relative humidity, compressor lock-out, fire shutdown, enthalpy, fan status, remote time clock/door switch.
 - 6. Shall accept a CO₂ sensor in the conditioned space, and be Demand Controlled Ventilation (DCV) ready.
 - 7. Shall provide the following outputs: economizer, fan, cooling stage 1, cooling stage 2, heat stage 1, heat stage 2, heat stage 3/ exhaust/ reversing valve/ dehumidify/ occupied.
 - 8. Unit shall provide surge protection for the controller through a circuit breaker.
 - 9. Shall be Internet capable, and communicate at a Baud rate of 38.4K or faster.
 - 10. Shall have an LED display independently showing the status of activity on the communication bus, and processor operation.

11. Shall include an EIA-485 protocol communication port, an access port for connection of either a computer or a Carrier technician tool, an EIA-485 port for network communication to intelligent space sensors and displays, and a port to connect an optional LonWorks* plug-in communications card.
12. Shall have built-in Carrier Comfort Network® (CCN) protocol, and be compatible with other CCN devices, including ComfortVIEW™ controllers.
13. Shall have built-in support for Carrier technician tool.
14. Software upgrades will be accomplished by local download. Software upgrades through chip replacements are not allowed.
15. Shall be shock resistant in all planes to 5G peak, 11ms during operation, and 100G peak, 11ms during storage.
16. Shall be vibration resistant in all planes to 1.5G at 20-300 Hz.
17. Shall support a bus length of 4000 ft (1219 m) max, 60 devices per 1000 ft (305 m) section, and 1 RS-485 repeater per 1000 ft (305 m) sections.

* LonWorks is a registered trademark of Echelon Corporation.

23 09 23.13.B. RTU Open protocol, direct digital controller:

1. Shall be ASHRAE 62 compliant.
2. Shall accept 18-30VAC, 50-60Hz, and consume 15VA or less power.
3. Shall have an operating temperature range from -40°F (-40°C) to 130°F (54°C), 10% - 90% RH (non-condensing).
4. Shall include built-in protocol for BACnet† (MS/TP and PTP modes), Modbus** (RTU and ASCII), Johnson N2 and LonWorks. LonWorks Echelon processor required for all Lon applications shall be contained in separate communication board.
5. Shall allow access of up to 62 network variables (SNVT). Shall be compatible with all open controllers.
6. Baud rate controller shall be selectable using a dipswitch.
7. Shall have an LED display independently showing the status of serial communication, running, errors, power, all digital outputs, and all analog inputs.
8. Shall accept the following inputs: space temperature, setpoint adjustment, outdoor air temperature, indoor air quality, outdoor air quality, compressor lock-out, fire shutdown, enthalpy switch, and fan status/filter status/humidity/ remote occupancy.
9. Shall provide the following outputs: economizer, fan, cooling stage 1, cooling stage 2, heat stage 1, heat stage 2, heat stage 3/ exhaust/ reversing valve.
10. Shall have built-in surge protection circuitry through solid-state polyswitches. Polyswitches shall be used on incoming power and network connections. Polyswitches will return to normal when the “trip” condition clears.
11. Shall have a battery back-up capable of a minimum of 10,000 hours of data and time clock retention during power outages.
12. Shall have built-in support for Carrier technician tool.
13. Shall include an EIA-485 protocol communication port, an access port for connection of either a computer or a Carrier technician tool, an EIA-485 port for network communication to intelligent space sensors and displays, and a port to connect an optional LonWorks communications card.
14. Software upgrades will be accomplished by either local or remote download. No software upgrades through chip replacements are allowed.

† BACnet is a registered trademark of ASHRAE (American Society of Heating, Refrigerating and Air-Conditioning Engineers).

** Modbus is a registered trademark of Schneider Electric.

23 09 23.13.C. ComfortLink Unit Controls shall contain:

1. Four button detailed English scrolling marquee display.
2. CCN (Carrier Comfort Network) capable.
3. Unit control with standard suction pressure transducers and condensing temperature thermistors.
4. Shall provide a 5°F temperature difference between cooling and heating set points to meet ASHRAE 90.1-2013 Energy Standard.
5. Shall provide and display a current alarm list and an alarm history list.
6. Service run test capability.
7. Shall accept input from a CO₂ sensor (both indoor and outdoor).
8. Configurable alarm light shall be provided which activates when certain types of alarms occur.
9. Compressor minimum run time (3 minutes) and minimum off time (5 minutes) are provided.
10. Service diagnostic mode.
11. Economizer control (optional).
12. Control multiple capacity stages.
13. Unit shall be complete with self-contained low voltage control circuit.

14. Unit shall have 0°F low ambient cooling operation.

23 09 33 Electric and Electronic Control System for HVAC

23 09 33.13 Decentralized, Rooftop Units:

23 09 33.13.A. General:

1. Shall be complete with self-contained low-voltage control circuit protected by a resettable circuit breaker on the 24-v transformer side. Transformer shall have 75VA capability.
2. Shall utilize color-coded wiring.
3. Shall include a central control terminal board to conveniently and safely provide connection points for vital control functions such as: smoke detectors, phase monitor, gas controller, economizer, thermostat, DDC control options, and low and high pressure switches.
4. The heat exchanger shall be controlled by an integrated gas controller (IGC) microprocessor. See heat exchanger section of this specification.
5. Unit shall include a minimum of one 8-pin screw terminal connection board for connection of control wiring.

23 09 33.13.B. Safeties:

1. Compressor over-temperature, over-current. High internal pressure differential.
2. Low-pressure switch.
 - a. Units shall have different sized connectors for the circuit 1 and circuit 2 low and high pressure switches. They shall physically prevent the cross-wiring of the safety switches between circuits 1 and 2.
 - b. Low-pressure switch shall use different color wire than the high-pressure switch. The purpose is to assist the installer and service technician to correctly wire and or troubleshoot the rooftop unit.
3. High-pressure switch.
 - a. Units shall have different sized connectors for the circuit 1 and circuit 2 low and high pressure switches. They shall physically prevent the cross-wiring of the safety switches between circuits 1 and 2.
 - b. High-pressure switch shall use different color wire than the low-pressure switch. The purpose is to assist the installer and service technician to correctly wire and or troubleshoot the rooftop unit.
4. Automatic reset, motor thermal overload protector.
5. Heating section shall be provided with the following minimum protections:
 - a. High-temperature limit switches.
 - b. Induced draft motor speed sensor.
 - c. Flame rollout switch.
 - d. Flame proving controls.

23 09 93 Sequence of Operations for HVAC Controls

23 09 93.13 Decentralized, Rooftop Units:

23 09 93.13.A. INSERT SEQUENCE OF OPERATION

23 40 13 Panel Air Filters

23 40 13.13 Decentralized, Rooftop Units:

23 40 13.13.A. Standard filter section

1. Shall consist of factory-installed, low velocity, disposable 2-in. thick fiberglass filters of commercially available sizes.
2. Unit shall use only one filter size. Multiple sizes are not acceptable.
3. Filters shall be accessible through a dedicated, weather tight access panel.
4. 4-in filter capabilities shall be capable with pre-engineered and approved Carrier filter track field-installed accessory. This kit requires field furnished filters.

23 81 19 Self-Contained Air Conditioners

23 81 19.13 Medium-Capacity Self-Contained Air Conditioners (48HC**17-28)

23 81 19.13.A. General

1. Outdoor, rooftop mounted, electrically controlled, heating and cooling unit utilizing a fully hermetic scroll compressor(s) for cooling duty and gas combustion for heating duty.
2. Factory assembled, single-piece heating and cooling rooftop unit. Contained within the unit enclosure shall be all factory wiring, piping, controls, and special features required prior to field start-up.
3. Unit shall use Puron[®] refrigerant.
4. Unit shall be installed in accordance with the manufacturer's instructions.
5. Unit must be selected and installed in compliance with local, state, and federal codes.

23 81 19.13.B. Quality Assurance

1. Unit meets ASHRAE 90.1-2013 minimum efficiency requirements.
2. Units are Energy Star certified where sizes are required.
3. Unit shall be rated in accordance with AHRI Standard 340/360.
4. Unit shall be designed to conform to ASHRAE 15.
5. Unit shall be ETL-tested and certified in accordance with ANSI Z21.47 Standards and ETL-listed and certified under Canadian standards as a total package for safety requirements.
6. Insulation and adhesive shall meet NFPA 90A requirements for flame spread and smoke generation.
7. Unit internal insulation linings shall be resistant to mold growth in accordance with “mold growth and humidity” test in ASTM C1338, G21, and UL 181 or comparable test method. Air stream surfaces shall be evaluated in accordance with the “Erosion Test” in UL 181, as part of ASTM C1071.
8. Unit casing shall be capable of withstanding 500-hour salt spray exposure per ASTM B117 (scribed specimen).
9. Roof curb shall be designed to conform to NRCA Standards.
10. Unit shall be subjected to a completely automated run test on the assembly line. The data for each unit will be stored at the factory, and must be available upon request.
11. Unit shall be designed in accordance with UL Standard 1995, ETL listed including tested to withstand rain.
12. Unit shall be constructed to prevent intrusion of snow and tested to prevent snow intrusion into the control box up to 40 mph.
13. Unit shake tested to assurance level 1, ASTM D4169 to ensure shipping reliability.
14. High-Efficiency Motors listed shall meet section 313 of the Energy Independence and Security Act of 2007 (EISA 2007).

23 81 19.13.C. Delivery, Storage, and Handling

1. Unit shall be stored and handled per manufacturer’s recommendations.
2. Lifted by crane requires either shipping top panel or spreader bars.
3. Unit shall only be stored or positioned in the upright position.

23 81 19.13.D. Project Conditions

1. As specified in the contract.

23 81 19.13.E. Operating Characteristics

1. Unit shall be capable of starting and running at 125°F (52°C) ambient outdoor temperature, meeting maximum load criteria of AHRI Standard 340/360 at ± 10% voltage.
2. Compressor with standard controls shall be capable of operation down to 35°F (2°C), ambient outdoor temperatures. Accessory winter start kit is necessary if mechanically cooling at ambient temperatures below 35°F (2°C).
3. Unit shall discharge supply air vertically or horizontally as shown on contract drawings.
4. Unit shall be factory configured and ordered for vertical supply & return configurations.
5. Unit shall be factory furnished for either vertical or horizontal configuration without the use of special conversion kits. No field conversion is possible.

23 81 19.13.F. Electrical Requirements

1. Main power supply voltage, phase, and frequency must match those required by the manufacturer.

23 81 19.13.G. Unit Cabinet

1. Unit cabinet shall be constructed of galvanized steel, and shall be bonderized and coated with a pre-painted baked enamel finish on all externally exposed surfaces.
2. Unit cabinet exterior paint shall be: film thickness, (dry) 0.003 inches minimum, gloss (per ASTM D523, 60°F / 16°C): 60, Hardness: H-2H Pencil hardness.
3. Evaporator fan compartment interior cabinet insulation shall conform to AHRI Standard 340/360 minimum exterior sweat criteria. Interior surfaces shall be insulated with a minimum 1/2-in. thick, 1 lb density, flexible fiberglass insulation, neoprene coated on the air side. Aluminum foil-faced fiberglass insulation shall be used in the gas heat compartment.
4. Unit internal insulation linings shall be resistant to mold growth in accordance with “mold growth and humidity” test in ASTM C1338, G21, and UL 181 or comparable test method. Air stream surfaces shall be evaluated in accordance with the “Erosion Test” in UL 181, as part of ASTM C1071.
5. Base of unit shall have a minimum of four locations for thru-the-base gas and electrical connections standard. Both gas and electric connections shall be internal to the cabinet to protect from environmental issues.
6. Base Rail
 - a. Unit shall have base rails on a minimum of 2 sides.
 - b. Holes shall be provided in the base rails for rigging shackles to facilitate maneuvering and overhead rigging.

- c. Holes shall be provided in the base rail for moving the rooftop by fork truck.
 - d. Base rail shall be a minimum of 16 gauge thickness.
7. Condensate pan and connections:
- a. Shall be a sloped condensate drain pan made of a non-corrosive material.
 - b. Shall comply with ASHRAE Standard 62.
 - c. Shall use a 3/4-in -14 NPT drain connection, through the side of the drain pan. Connection shall be made per manufacturer's recommendations.
8. Top panel:
- a. Shall be a multi-piece top panel linked with water tight flanges and locking systems.
9. Gas Connections:
- a. All gas piping connecting to unit gas valve shall enter the unit cabinet at a single location on side of unit (horizontal plane).
 - b. Thru-the-base capability
 - (1.) Standard unit shall have a thru-the-base gas-line location using a raised, embossed portion of the unit basepan.
 - (2.) Thru-the-base provisions/connections are available as standard with every unit. When bottom connections are required, field furnished couplings are required.
 - (3.) No basepan penetration, other than those authorized by the manufacturer, is permitted.
10. Electrical Connections
- a. All unit power wiring shall enter unit cabinet at a single, factory-prepared, knockout location.
 - b. Thru-the-base capability.
 - (1.) Thru-the-base provisions/connections are available as standard with every unit. When bottom connections are required, field furnished couplings are required.
 - (2.) No basepan penetration, other than those authorized by the manufacturer, is permitted.
11. Component access panels (standard)
- a. Cabinet panels shall be easily removable for servicing.
 - b. Unit shall have one factory-installed, tool-less, removable, filter access panel.
 - c. Panels covering control box and filter shall have molded composite handles while the blower access door shall have an integrated flange for easy removal.
 - d. Handles shall be UV modified, composite. They shall be permanently attached, and recessed into the panel.
 - e. Screws on the vertical portion of all removable access panel shall engage into heat resistant, molded composite collars.
 - f. Collars shall be removable and easily replaceable using manufacturer recommended parts.
- 23 81 19.13.H. Gas Heat
1. General
- a. Heat exchanger shall be an induced draft design. Positive pressure heat exchanger designs shall not be allowed.
 - b. Shall incorporate a direct-spark ignition system and redundant main gas valve.
 - c. Gas supply pressure at the inlet to the rooftop unit gas valve must match that required by the manufacturer.
2. The heat exchanger shall be controlled by an integrated gas controller (IGC) microprocessor.
- a. IGC board shall notify users of fault using an LED (light-emitting diode).
 - b. IGC board shall contain algorithms that modify evaporator-fan operation to prevent future cycling on high temperature limit switch.
 - c. Unit shall be equipped with anti-cycle protection with one short cycle on unit flame rollout switch or 4 continuous short cycles on the high temperature limit switch. Fault indication shall be made using an LED.
3. Standard Heat Exchanger construction
- a. Heat exchanger shall be of the tubular-section type constructed of a minimum of 20-gauge steel coated with a nominal 1.2 mil aluminum-silicone alloy for corrosion resistance.
 - b. Burners shall be of the in-shot type constructed of aluminum-coated steel.
 - c. Burners shall incorporate orifices for rated heat output up to 2000 ft (610 m) elevation. Additional accessory kits may be required for applications above 2000 ft (610 m) elevation, depending on local gas supply conditions.
 - d. Each heat exchanger tube shall contain multiple dimples for increased heating effectiveness.
4. Optional Stainless Steel Heat Exchanger construction
- a. Use energy saving, direct-spark ignition system.
 - b. Use a redundant main gas valve.

- c. Burners shall be of the in-shot type constructed of aluminum-coated steel.
 - d. All gas piping shall enter the unit cabinet at a single location on side of unit (horizontal plane).
 - e. The optional stainless steel heat exchanger shall be of the tubular-section type, constructed of a minimum of 20-gauge type 409 stainless steel.
 - f. Type 409 stainless steel shall be used in heat exchanger tubes and vestibule plate.
 - g. Complete stainless steel heat exchanger allows for greater application flexibility.
5. Induced draft combustion motor and blower
- a. Shall be a direct-drive, single inlet, forward-curved centrifugal type.
 - b. Shall be made from steel with a corrosion-resistant finish.
 - c. Shall have permanently lubricated sealed bearings.
 - d. Shall have inherent thermal overload protection.
 - e. Shall have an automatic reset feature.

23 81 19.13.I. Coils

1. Standard Aluminum Fin/Copper Tube Coils:

- a. Standard evaporator and condenser coils shall have aluminum lanced plate fins mechanically bonded to seamless internally grooved copper tubes with all joints brazed.
- b. Evaporator coils shall be leak tested to 150 psig, pressure tested to 450 psig, and qualified to UL 1995 burst test at 1775 psig.
- c. Condenser coils shall be leak tested to 150 psig, pressure tested to 650 psig, and qualified to UL 1995 burst test at 1980 psig.

2. Optional Pre-coated aluminum-fin condenser coils:

- a. Shall have a durable epoxy-phenolic coating to provide protection in mildly corrosive coastal environments.
- b. Coating shall be applied to the aluminum fin stock prior to the fin stamping process to create an inert barrier between the aluminum fin and copper tube.
- c. Epoxy-phenolic barrier shall minimize galvanic action between dissimilar metals.
- d. Corrosion durability of fin stock shall be confirmed through testing to be no less than 1000 hours salt spray per ASTM B117-90.
- e. Corrosion durability of fin stock shall be confirmed through testing to have no visible corrosion after 48 hour immersion in a room temperature solution of 5% salt, 1% acetic acid.
- f. Fin stock coating shall pass 2000 hours of the following: one week exposure in the prohesion chamber followed by one week of accelerated ultraviolet light testing. Prohesion chamber: the solution shall contain 3.5% sodium chloride and 0.35% ammonium sulfate. The exposure cycle is one hour of salt fog application at ambient followed by one hour drying at 95°F (35°C).

3. Optional Copper-fin evaporator and condenser coils:

- a. Shall be constructed of copper fins mechanically bonded to copper tubes and copper tube sheets.
- b. Galvanized steel tube sheets shall not be acceptable.
- c. A polymer strip shall prevent coil assembly from contacting the sheet metal coil pan to minimize potential for galvanic corrosion between coil and pan.

4. Optional E-coated aluminum-fin evaporator and condenser coils:

- a. Shall have a flexible epoxy polymer coating uniformly applied to all coil surface areas without material bridging between fins.
- b. Coating process shall ensure complete coil encapsulation of tubes, fins and headers.
- c. Color shall be high gloss black with gloss per ASTM D523-89.
- d. Uniform dry film thickness from 0.8 to 1.2 mil on all surface areas including fin edges.
- e. Superior hardness characteristics of 2H per ASTM D3363-92A and cross-hatch adhesion of 4B-5B per ASTM D3359-93.
- f. Impact resistance shall be up to 160 in.-lb (ASTM D2794-93).
- g. Humidity and water immersion resistance shall be up to minimum 1000 and 250 hours respectively (ASTM D2247-92 and ASTM D870-92).
- h. Corrosion durability shall be confirmed through testing to be no less than 6000 hours salt spray per ASTM B117-90.

5. Optional E-coated aluminum-fin, aluminum tube condenser coils:

- a. Shall have a flexible epoxy polymer coating uniformly applied to all coil external surface areas without material bridging between fins or louvers.
- b. Coating process shall ensure complete coil encapsulation, including all exposed fin edges.

- c. E-coat thickness of 0.8 to 1.2 mil with top coat having a uniform dry film thickness from 1.0 to 2.0 mil on all external coil surface areas, including fin edges, shall be provided.
- d. Shall have superior hardness characteristics of 2H per ASTM D3363-00 and cross-hatch adhesion of 4B-5B per ASTM D3359-02.
- e. Shall have superior impact resistance with no cracking, chipping or peeling per NSF/ANSI 51-2002 Method 10.2.

23 81 19.13.J. Refrigerant Components

- 1. Refrigerant circuit shall include the following control, safety, and maintenance features:
 - a. Thermostatic Expansion Valve (TXV) shall help provide optimum performance across the entire operating range. Shall contain removable power element to allow change out of power element and bulb without removing the valve body.
 - b. Refrigerant filter drier.
 - c. Service gauge connections on suction and discharge lines.
 - d. Pressure gauge access through a specially designed access screen on the side of the unit.
- 2. Compressors
 - a. Unit shall use fully hermetic, scroll compressor for each independent refrigeration circuit.
 - b. Models shall be available with 2 compressor/2-stage cooling.
 - c. Compressor motors shall be cooled by refrigerant gas passing through motor windings.
 - d. Compressors shall be internally protected from high discharge temperature conditions.
 - e. Compressors shall be protected from an over-temperature and over-ampere conditions by an internal, motor overload device.
 - f. Compressor shall be factory mounted on rubber grommets.
 - g. Compressor motors shall have internal line break thermal, current overload and high pressure differential protection.
 - h. Crankcase heaters shall not be required for normal operating range, unless provided by the factory.

23 81 19.13.K. Filter Section

- 1. Filters access is specified in the unit cabinet section of this specification.
- 2. Filters shall be held in place by a preformed, slide-out filter tray, facilitating easy removal and installation.
- 3. Shall consist of factory-installed, low velocity, throw-away 2-in. thick fiberglass filters.
- 4. Filters shall be standard, commercially available sizes.
- 5. Only one size filter per unit is allowed.
- 6. 4-in filter capability is possible with a field-installed pre-engineered slide out filter track accessory. 4-in filters are field furnished.

23 81 19.13.L. Evaporator Fan and Motor

- 1. Evaporator fan motor:
 - a. Shall have inherent automatic-reset thermal overload protection or circuit breaker.
 - b. Shall have a maximum continuous bhp rating for continuous duty operation; no safety factors above that rating shall be required.
- 2. Belt-driven Evaporator Fan:
 - a. Belt drive shall include an adjustable-pitch motor pulley and belt break protection system.
 - b. Shall use rigid pillow block bearing system with lubricant fittings at accessible bearing or lubrication line.
 - c. Blower fan shall be double-inlet type with forward-curved blades.
 - d. Shall be constructed from steel with a corrosion resistant finish and dynamically balanced.

23 81 19.13.M. Condenser Fans and Motors

- 1. Condenser fan motors:
 - a. Shall be a totally enclosed motor.
 - b. Shall use permanently lubricated bearings.
 - c. Shall have inherent thermal overload protection with an automatic reset feature.
 - d. Shall use a shaft-down design.
- 2. Condenser Fans:
 - a. Shall be a direct-driven propeller type fan.
 - b. Shall have aluminum blades riveted to corrosion-resistant steel spiders and shall be dynamically balanced.

23 81 19.13.N. Special Features Options and Accessories

- 1. Staged Air Volume System (SAV™) for 2-stage cooling models only:

- a. Evaporator fan motor:
 - (1.) Shall have permanently lubricated bearings.
 - (2.) Shall have a maximum continuous bhp rating for continuous duty operation; no safety factors above that rating.
 - (3.) Shall be Variable Frequency duty and 2-speed control.
 - (4.) Shall contain motor shaft grounding ring to prevent electrical bearing fluting damage by safely diverting harmful shaft voltages and bearing currents to ground.
2. Variable Frequency Drive (VFD). Only available on 2-speed indoor fan motor option (SAV):
 - a. Factory-supplied VFDs qualify, through ABB, for a 24-month warranty from date of commissioning or 30 months from date of sale, whichever occurs first.
 - b. Shall be installed inside the unit cabinet, mounted, wired and tested.
 - c. Shall contain Electromagnetic Interference (EMI) frequency protection.
 - d. Insulated Gate Bi-Polar Transistors (IGBT) used to produce the output pulse width modulated (PWM) waveform, allowing for quiet motor operation.
 - e. Self diagnostics with fault and power code LED indicator. Field accessory Display Kit available for further diagnostics and special setup applications.
 - f. RS485 capability standard.
 - g. Electronic thermal overload protection.
 - h. 5% swinging chokes for harmonic reduction and improved power factor.
 - i. All printed circuit boards shall be conformal coated.
3. Integrated EconoMi\$er IV, EconoMi\$er 2, and EconoMi\$er X standard leak rate models. (Factory or field-installed)
 - a. Integrated, gear driven opposing modulating blade design type capable of simultaneous economizer and compressor operation.
 - b. Modules for vertical or horizontal return configuration shall be available.
 - c. Damper blades shall be galvanized steel with composite gears. Plastic or composite blades on intake or return shall not be acceptable.
 - d. Shall include all hardware and controls to provide free cooling with outdoor air when temperature and/or humidity are below setpoints.
 - e. Shall be equipped with gear driven dampers for both the outdoor ventilation air and the return air for positive air stream control.
 - f. Standard leak rate models shall be equipped with dampers not to exceed 2% leakage at 1 in. wg pressure differential.
 - g. Economizer controller on EconoMi\$er IV models shall be the Honeywell W7212 that provides:
 - (1.) Combined minimum and DCV maximum damper position potentiometers with compressor staging relay.
 - (2.) Functions with solid-state analog enthalpy or dry bulb changeover control sensing.
 - (3.) Contain LED indicates for: when free cooling is available, when module is in DCV mode, when exhaust fan contact is closed.
 - h. Economizer controller on EconoMi\$er X models shall be the Honeywell W7220 that provides:
 - (1.) 2-line LCD interface screen for setup, configuration and troubleshooting
 - (2.) On-board Fault Detection and Diagnostics (FDD) that senses and alerts when the economizer is not operating properly, per California Title 24.
 - (3.) Sensor failure loss of communication identification.
 - (4.) Automatic sensor detection.
 - (5.) Capabilities for use with multiple-speed indoor fan systems.
 - (6.) Utilize digital sensors: Dry bulb and Enthalpy.
 - i. Economizer controller on EconoMi\$er 2 models with PremierLink™ controller shall be 4-20mA design and controlled by the PremierLink controller. PremierLink does not comply with California Title 24 Fault Detection & Diagnostic (FDD) requirements.
 - j. Economizer controller on EconoMi\$er 2 models with RTU Open models shall be a 4-20mA design controlled directly by the RTU Open controller. RTU Open meets California Title 24 Fault Detection & Diagnostic (FDD) requirements.
 - k. Economizer controller on EconoMi\$er 2 models with ComfortLink models shall be controlled directly by the ComfortLink controller. ComfortLink meets California Title 24 Fault Detection & Diagnostic (FDD) requirements.
 - l. Shall be capable of introducing up to 100% outdoor air.

- m. Shall be equipped with a barometric relief damper capable of relieving up to 100% return air and contain seals that meet ASHRAE 90.1-2013 requirements.
 - n. Shall be designed to close damper(s) during loss-of-power situations with spring return built into motor.
 - o. Dry bulb outdoor air temperature sensor shall be provided as standard. Enthalpy sensor is also available for factory-installed economizers only. Outdoor air sensor setpoint shall be adjustable and shall range from 40 to 100°F (4 to 38°C). Additional sensor options shall be available as accessories.
 - p. The economizer controller shall also provide control of an accessory power exhaust unit function. Factory set at 100%, with a range of 0% to 100%.
 - q. The economizer shall maintain minimum airflow into the building during occupied period and provide design ventilation rate for full occupancy.
 - r. Dampers shall be completely closed when the unit is in the unoccupied mode.
 - s. Economizer controller shall accept a 2-10 Vdc CO₂ sensor input for IAQ/DCV control. In this mode, dampers shall modulate the outdoor air damper to provide ventilation based on the sensor input.
 - t. Compressor lockout temperature on W7220 is adjustable from -45°F to 80°F, set at a factory default of 32°F. Others shall open at 35°F (2°C) and closes at 50°F (10°C).
 - u. Actuator shall be direct coupled to economizer gear. No linkage arms or control rods shall be acceptable.
 - v. Economizer controller shall provide indications when in free cooling mode, in the DCV mode, or the exhaust fan contact is closed.
4. Integrated EconoMi\$er 2 and EconoMi\$er X Ultra Low Leak rate models. (Factory or field-installed)
- a. Integrated, gear driven opposing modulating blade design type capable of simultaneous economizer and compressor operation.
 - b. Modules for vertical or horizontal return configuration shall be available.
 - c. Damper blades shall be galvanized steel with composite gears. Plastic or composite blades on intake or return shall not be acceptable.
 - d. Shall include all hardware and controls to provide free cooling with outdoor air when temperature and/or humidity are below setpoints.
 - e. Shall be equipped with gear driven dampers for both the outdoor ventilation air and the return air for positive air stream control.
 - f. Ultra Low Leak design meets California Title 24 section 140.4 and ASHRAE 90.1-2013 requirements of 4 cfm per sq. ft. on the outside air dampers and 10 cfm per sq. ft. on the return dampers.
 - g. Economizer controller on EconoMi\$er X models shall be the Honeywell W7220 that provides:
 - (1.) 2-line LCD interface screen for setup, configuration and troubleshooting.
 - (2.) On-board Fault Detection and Diagnostics (FDD) that senses and alerts when the economizer is not operating properly, per California Title 24.
 - (3.) Sensor failure loss of communication identification.
 - (4.) Automatic sensor detection.
 - (5.) Capabilities for use with multiple-speed indoor fan systems.
 - (6.) Utilize digital sensors: Dry bulb and Enthalpy.
 - h. Economizer controller on EconoMi\$er 2 models with RTU Open models shall be a 4-20mA design controlled directly by the RTU Open controller. RTU Open meets California Title 24 Fault Detection & Diagnostic (FDD) requirements.
 - i. Economizer controller on EconoMi\$er 2 models with ComfortLink models shall be controlled directly by the ComfortLink controller. ComfortLink meets California Title 24 Fault Detection & Diagnostic (FDD) requirements.
 - j. Shall be capable of introducing up to 100% outdoor air.
 - k. Shall be equipped with a barometric relief damper capable of relieving up to 100% return air and contain seals that meet ASHRAE 90.1-2013 requirements.
 - l. Shall be designed to close damper(s) during loss-of-power situations with spring return built into motor.
 - m. Dry bulb outdoor air temperature sensor shall be provided as standard. Enthalpy sensor is also available for factory-installed economizers only. Outdoor air sensor setpoint shall be adjustable and shall range from 40 to 100°F (4 to 38°C). Additional sensor options shall be available as accessories.
 - n. The economizer controller shall also provide control of an accessory power exhaust unit function. Factory set at 100%, with a range of 0% to 100%.
 - o. The economizer shall maintain minimum airflow into the building during occupied period and provide design ventilation rate for full occupancy.
 - p. Dampers shall be completely closed when the unit is in the unoccupied mode.

- q. Economizer controller shall accept a 2-10 Vdc CO₂ sensor input for IAQ/DCV control. In this mode, dampers shall modulate the outdoor air damper to provide ventilation based on the sensor input.
 - r. Compressor lockout temperature on W7220 is adjustable from -45°F to 80°F, set at a factory default of 32°F. Others shall open at 35°F (2°C) and closes at 50°F (10°C).
 - s. Actuator shall be direct coupled to economizer gear. No linkage arms or control rods shall be acceptable.
 - t. Economizer controller shall provide indications when in free cooling mode, in the DCV mode, or the exhaust fan contact is closed.
5. Two-Position Motorized Damper
 - a. Damper shall be a 2-position damper. Damper travel shall be from the full closed position to the field adjustable %-open setpoint.
 - b. Damper shall include adjustable damper travel from 25% to 100% (full open).
 - c. Damper shall include single or dual blade, gear driven dampers and actuator motor.
 - d. Actuator shall be direct coupled to damper gear. No linkage arms or control rods shall be acceptable.
 - e. Damper will admit up to 100% outdoor air for applicable rooftop units.
 - f. Damper shall close upon indoor (evaporator) fan shutoff and/or loss of power.
 - g. The damper actuator shall plug into the rooftop unit's wiring harness plug. No hard wiring shall be required.
 - h. Outside air hood shall include aluminum water entrainment filter.
 6. Manual damper
 - a. Manual damper package shall consist of damper, air inlet screen, and rain hood which can be preset to admit up to 25% outdoor air for year round ventilation.
 7. Humidi-MiZer[®] Adaptive Dehumidification System
 - a. The Humidi-MiZer Adaptive Dehumidification System shall be factory-installed and shall provide greater dehumidification of the occupied space by two modes of dehumidification operations in addition to its normal design cooling mode:
 - (1.) Subcooling mode further sub cools the hot liquid refrigerant leaving the condenser coil when both temperature and humidity in the space are not satisfied.
 - (2.) Hot gas reheat mode shall mix a portion of the hot gas from the discharge of the compressor with the hot liquid refrigerant leaving the condenser coil to create a two-phase heat transfer in the system, resulting in a neutral leaving-air temperature when only humidity in the space is not satisfied.
 - (3.) Includes head pressure controller.
 8. Head Pressure Control Package (Motormaster[®])
 - a. Controller shall control coil head pressure by condenser-fan speed modulation or condenser-fan cycling and wind baffles.
 - b. Shall consist of solid-state control and condenser-coil temperature sensor to maintain condensing temperature between 90°F (32°C) and 110°F (43°C) at outdoor ambient temperatures down to -20°F (-29°C).
 9. Low Ambient Controller (Factory-installed only)
 - a. Controller shall control coil head pressure by condenser-fan speed modulation or condenser-fan cycling and wind baffles.
 - b. Shall consist of solid-state control and condenser-coil temperature sensor to maintain condensing temperature between 90°F (32°C) and 110°F (43°C) at outdoor ambient temperatures down to 0°F (-18°C).
 10. Propane Conversion Kit
 - a. Package shall contain all the necessary hardware and instructions to convert a standard natural gas unit for use with liquefied propane. Kits shall be available for elevations from 0 up to 14,000 ft (4,276 m).
 11. Condenser Coil Hail Guard Assembly
 - a. Shall protect against damage from hail.
 - b. Shall be louvered style design.
 12. Unit-Mounted, Non-Fused Disconnect Switch:
 - a. Switch shall be factory-installed, internally mounted.
 - b. National Electric Code (NEC) and UL approved non-fused switch shall provide unit power shutoff.
 - c. Shall be accessible from outside the unit.
 - d. Shall provide local shutdown and lockout capability.
 - e. Sized only for the unit as ordered from the factory. Does not accommodate field-installed devices.
 13. HACR Breaker
 - a. These manual reset devices provide overload and short circuit protection for the unit. Factory wired and mounted with the units, with access cover to help provide environmental protection. On 575V applications,

- HACR breaker can only be used with WYE power distribution systems. Use on Delta power distribution systems is prohibited.
- b. Sized only for the unit as ordered from the factory. Does not accommodate field-installed devices.
14. Convenience Outlet:
 - a. Powered convenience outlet.
 - (1.) Outlet shall be powered from main line power to the rooftop unit.
 - (2.) Outlet shall be powered from line side of disconnect by installing contractor, as required by code. If outlet is powered from load side of disconnect, unit electrical ratings shall be ETL certified and rated for additional outlet amperage.
 - (3.) Outlet shall be factory-installed and internally mounted with easily accessible 115-v female receptacle.
 - (4.) Outlet shall include 15 amp GFI receptacles with independent fuse protection.
 - (5.) Voltage required to operate convenience outlet shall be provided by a factory-installed step-down transformer.
 - (6.) Outlet shall be accessible from outside the unit.
 - (7.) Outlet shall include a field-installed “Wet in Use” cover.
 - b. Non-Powered convenience outlet.
 - (1.) Outlet shall be powered from a separate 115/120v power source.
 - (2.) A transformer shall not be included.
 - (3.) Outlet shall be factory-installed and internally mounted with easily accessible 115-v female receptacle.
 - (4.) Outlet shall include 15 amp GFI receptacles with independent fuse protection.
 - (5.) Outlet shall be accessible from outside the unit.
 - (6.) Outlet shall include a field-installed “Wet in Use” cover.
 15. Flue Discharge Deflector:
 - a. Flue discharge deflector shall direct unit exhaust vertically instead of horizontally.
 - b. Deflector shall be defined as a “natural draft” device by the National Fuel and Gas (NFG) code.
 16. Fan/Filter Status Switch:
 - a. Switch shall provide status of indoor evaporator fan (ON/OFF) or filter (CLEAN/DIRTY).
 - b. Status shall be displayed either over communication bus (when used with direct digital controls) or with an indicator light at the thermostat.
 17. Centrifugal Propeller Power Exhaust:
 - a. Power exhaust shall be used in conjunction with an integrated economizer.
 - b. Independent modules for vertical or horizontal return configurations shall be available.
 - c. Horizontal power exhaust is shall be mounted in return ductwork.
 - d. Power exhaust shall be controlled by economizer controller operation. Exhaust fans shall be energized when dampers open past the 0-100% adjustable setpoint on the economizer control.
 18. Roof Curbs (Vertical):
 - a. Full perimeter roof curb with exhaust capability providing separate air streams for energy recovery from the exhaust air without supply air contamination.
 - b. Formed galvanized steel with wood nailer strip and shall be capable of supporting entire unit weight.
 - c. Permits installation and securing of ductwork to curb prior to mounting unit on the curb.
 19. Adapter Curb (Vertical):
 - a. Full perimeter – fully assembled and welded roof curb with exhaust capability providing separate air streams for energy recovery from the exhaust air without supply air contamination.
 - b. Formed galvanized steel with wood nailer strip and shall be capable of supporting entire unit weight.
 - c. Permits installation of new 48HC 17-28 models to past Carrier design curb models: DP, DR, HJ, TM, and TJ. (Not for 48TJE024-028 models.) Check with Carrier sales expert of further details and information.
 20. High Altitude Gas Conversion Kit:
 - a. Package shall contain all the necessary hardware and instructions to convert a standard natural gas unit to operate from 3,000-10,000 ft (914 to 3048 m) elevation and 10,001-14,000 ft (3049-4267 m) elevation.
 21. Outdoor Air Enthalpy Sensor:
 - a. The outdoor air enthalpy sensor shall be used to provide single enthalpy control. When used in conjunction with a return air enthalpy sensor, the unit will provide differential enthalpy control. The sensor allows the unit to determine if outside air is suitable for free cooling.
 22. Return Air Enthalpy Sensor:

- a. The return air enthalpy sensor shall be used in conjunction with an outdoor air enthalpy sensor to provide differential enthalpy control.
23. Indoor Air Quality (CO₂) Sensor:
 - a. Shall be able to provide demand ventilation indoor air quality (IAQ) control.
 - b. The IAQ sensor shall be available in duct mount, wall mount, or wall mount with LED display. The setpoint shall have adjustment capability.
24. Smoke detectors:
 - a. Shall be a Four-Wire Controller and Detector.
 - b. Shall be environmental compensated with differential sensing for reliable, stable, and drift-free sensitivity.
 - c. Shall use magnet-activated test/reset sensor switches.
 - d. Shall have tool-less connection terminal access.
 - e. Shall have a recessed momentary switch for testing and resetting the detector.
 - f. Controller shall include:
 - (1.) One set of normally open alarm initiation contacts for connection to an initiating device circuit on a fire alarm control panel.
 - (2.) Two Form-C auxiliary alarm relays for interface with rooftop unit or other equipment.
 - (3.) One Form-C supervision (trouble) relay to control the operation of the Trouble LED on a remote test/reset station.
 - (4.) Capable of direct connection to two individual detector modules.
 - (5.) Can be wired to up to 14 other duct smoke detectors for multiple fan shutdown applications
25. Horn/Strobe Annunciator
 - a. Provides an audible/visual signaling device for use with factory-installed option or field-installed accessory smoke detectors.
 - (1.) Requires installation of a field-supplied 24-v transformer suitable for 4.2 VA (AC) or 3.0 VA (DC) per horn/strobe accessory.
 - (2.) Requires field-supplied electrical box, North American 1-gang box, 2-in (51 mm) x 4-in (102 mm).
 - (3.) Shall have a clear colored lens.
26. Winter start kit
 - a. Shall contain a bypass device around the low pressure switch.
 - b. Shall be required when mechanical cooling is required down to 25°F (-4°C).
 - c. Shall not be required to operate on an economizer when below an outdoor ambient of 40°F (4°C).
27. Time Guard
 - a. Shall prevent compressor short cycling by providing a 5-minute delay (±2 minutes) before restarting a compressor after shutdown for any reason.
 - b. One device shall be required per compressor.
28. Barometric Hood (Horizontal Economizer Applications)
 - a. Shall be required when a horizontal economizer and barometric relief are required. Barometric relief damper must be installed in the return air (horizontal) duct work. This hood provides weather protection.
29. Display Kit for Variable Frequency Drive
 - a. Kit allows the ability to access the VFD controller programs to provide special setup capabilities and diagnostics.
 - b. Kit contains display module and communication cable.
 - c. Display Kit can be permanently installed in the unit or used on any SAV™ system VFD controller as needed.
30. Condensate Overflow Switch (for units with electro-mechanical controls only):
 - a. This sensor and related controller monitors the condensate level in the drain pan and shuts down compression operation when overflow conditions occur. It includes:
 - (1.) Indicator light - solid red (more than 10 seconds on water contact - compressors disabled), blinking red (sensor disconnected).
 - (2.) 10 second delay to break - eliminates nuisance trips from splashing or waves in pan (sensor needs 10 seconds of constant water contact before tripping).
 - (3.) Disables the compressor(s) operation when condensate plug is detected, but still allows fans to run for Economizer.
31. Hinged Access Panels
 - a. Shall provide easy access through integrated quarter turn latches.

- b. Shall be on major panels of – filter, control box, fan motor and compressor.
- 32. Foil faced insulation
 - a. Throughout unit cabinet air stream, non-fibrous and cleanable foil faced insulation is used.
- 33. Energy Demand System - EDS (field-installed accessory):
 - a. Shall utilize wireless network communication to optimize rooftop unit energy usage, up to 875 yds and up to 49 load controllers for each gateway. A wireless cellular signal shall be utilized to communicate energy information to/from the customer web portal.
 - b. Shall utilize explicit algorithms to minimize rooftop electrical demand charges, customizable to each facility.
 - c. Shall allow scheduling of rooftop units and provide a “staggered start” approach to minimize electrical consumption charges, customized to each facility.
 - d. Scheduling, adjustments, and sub-metered electrical data shall be accessible through a web based customer portal.
 - e. Shall provide demand response capability, including compliance with Open ADR protocol.
 - f. Shall utilize an external 4-pole relay and an internal single pole relay.
 - g. Shall use (2) split core transformers to provide real-time sub-metered electrical usage.



