

48LC WeatherExpert® Series
Ultra High–Efficiency
Single Package Rooftop and Single Zone VAV
Gas Heat/Electric Cooling Unit
Sizes 14 – 26 with Puron® (R–410A) Refrigerant
12.5– 23 Ton



Product Data



WeatherExpert®



Unit shown with Economizer and Power Exhaust

C160064

TABLE OF CONTENTS

	PAGE		PAGE
UNIT FEATURES	3	OPTIONS AND ACCESSORY WEIGHTS	28
MODEL NUMBER NOMENCLATURE	4	APPLICATION DATA	29
FACTORY OPTIONS AND/OR ACCESSORIES	5	COOLING CAPACITY TABLES	31
AHRI COOLING RATING TABLES	9	STATIC PRESSURE ADDERS	51
HEATING RATING TABLE	10	ECONO, BARO RELIEF & PE PERFORMANCE ...	52
SOUND PERFORMANCE TABLE	10	FAN PERFORMANCE	53
COOLING MIN/MAX AIRFLOW RATINGS	10	ELECTRICAL INFORMATION	60
HEATING MIN/MAX CFM	11	WIRING DIAGRAMS	66
PHYSICAL DATA	12	SEQUENCE OF OPERATION	70
UNIT: DIMENSIONS, WEIGHTS & CURBS	15	GUIDE SPECIFICATIONS	74



48LC

Carrier’s new Gas Heat / Electric Cooling WeatherExpert® 12.5 to 23 ton Commercial Package Rooftop models are designed to provide total low cost of ownership by providing some of the highest cooling efficiencies in the industry with low installed costs, low maintenance costs, and high reliability. These models focus on providing high IEERs (Integrated Energy Efficiency Ratios) which are a measurement of cooling part load performance and where actual buildings operate nearly all of the time. These high part load values are achieved by using logic that strategically sequences compressor stages, indoor fan motor and condenser fan motor speeds. These models are in addition to the 3 to 5 ton models with SEERs up to 17.5 and 6 to 10 ton models with IEERs up to 20.8 to provide a full range offering.

Ultra high efficiency:

With IEERs up to 19.1, these new WeatherExpert models help to contribute in LEED credits and help qualify for rebates. The high IEER efficiencies are achieved by utilizing a proven staged compressor design on a single refrigerant circuit that provides three stages of cooling capacity control. The indoor fan motors are high efficiency belt drive and controlled by a VFD (Variable Frequency Drive) system that matches the cooling capacity stages for optimum comfort and efficient control.

Gas heat is provided with efficiencies up to 81% and two stages of operation to better match building loads. Models also have multiple heat capacities for each size and use an induced draft combustion system.

Easy to install:

Units are designed for dedicated factory-supplied vertical or horizontal air flow duct configuration. No special field kits are required. Designed to fit on pre-installed curbs by another manufacturer, these units also fit on past designed Carrier installed curbs with an authorized adapter curb. The cabinet design also integrates a large control box that gives you room to work and room to mount Carrier accessory controls.

Easy to maintain:

Easy access door handles by Carrier provide quick access to all normally serviced components. Our “no-strip” screw system has superior holding power and guides screws into position while preventing the screw from stripping the unit’s metal. Units come with accessible 2-inch filter that have a dedicated access door for easy replacement. Optional hinged panels allow easy access with pull tabs and quarter turn latches.

Reliable:

Carrier conducts rigorous testing to insure your unit will perform as designed. Extensive rain testing is conducted in special designed test areas and under conditions that simulate actual job sites. In addition, units are both shake tested and driven around the country to make sure not only the packaging holds up, but the unit components within. Condensate pans are made of non corrosive – composite material, motors are permanently lubricated and compressors use crankcase heaters, all to further strengthen the unit’s reliability.



UNIT FEATURES

- Three-stage cooling capacity control with staged scroll compressors design. Each stage is different in capacity output to better match typical building load profiles.
- Single refrigerant circuit design with precision sized TXV refrigerant metering devices to provide optimum operation through the entire operating range.
- Single full faced evaporator coil for full surface utilization, even at part load operation.
- Crankcase heater on each compressor designed to cycle off during the on cycle.
- IEER up to 19.1 and EERs up to 12.5.
- High efficiency permanently lubricated belt driven evaporator-fan motor with VFD (Variable Frequency Drive) controller.
- Electro-Mechanical Integrated Staging Control (ISC) board that provides:
 - Thermostat controls
 - Compressor staging
 - Indoor fan motor staging
 - Field and factory wiring connections
 - Outdoor fan motor staging
 - Crank case heater control
- Sound levels as low as 84 dB.
- Exclusive non-corrosive composite condensate pan in accordance with ASHRAE 62 Standard, sloping design; side or bottom drain.
- Multiple gas heat sizes with heating efficiencies up to 81%.
- Induced draft combustion design.
- Redundant gas valve, with up to 2 stages of heating.
- Pre-painted exterior panels and primer-coated interior panels tested to 500 hours salt spray protection.
- Fully insulated with foil faced insulation throughout the entire cabinet.
- Exclusive IGC solid-state control for on-board diagnostics with LED error code designation, burner control logic and energy saving indoor fan motor delay.
- High ambient cooling operation and ratings up to 125°F (52°C).
- Low ambient mechanical cooling operation down to 40°F (4°C). An economizer shall be the source of cooling in low ambient temperature conditions. When the outside air temperature is below 40°F (4°C), to reduce operating costs, mechanical cooling shall not be utilized.
- Access panels with easy grip handles.
- Innovative, easy starting, no-strip screw feature on unit access panels.
- Two-inch disposable return air filters.
- Tool-less filter access door.
- Dedicated vertical and horizontal airflow models available ordered as factory option. No special kits required.
- Provisions for thru-the-bottom power entry capability as standard.
- Single point gas and electric connections.
- Full perimeter base rail with built-in rigging adapters and fork truck slots.
- 24-volt control circuit protected with resettable circuit breaker.
- Totally enclosed high-efficiency ECM outdoor fan motor with permanently lubricated bearings.
- Low-pressure switch and high-pressure switch protection.
- Solid-state electronic direct spark ignition system.
- Flame roll-out safety protector.
- High capacity liquid line filter drier.
- Factory-installed Humidi-MiZer[®] Adaptive Dehumidification System on all sizes
- Factory-installed SystemVu[™] controller with LCD user display
- Standard Limited Parts Warranty: 10 yr. aluminized heat exchanger, 15 yr. stainless steel heat exchanger, 5 yr. compressor, 3 yr. SystemVu controller, 1 yr. parts.

MODEL NUMBER NOMENCLATURE

1	2	3	4	5	6	7	8	9	10	11	12	13	14	15	16	17	18
4	8	L	C	D	0	2	4	A	1	A	1	-	0	A	0	A	0

Unit Type

48 = Gas Heat Packaged Rooftop

Model Series – Weather Expert

LC = Ultra High Efficiency

Heat Size

D = Low gas heat
 E = Medium gas heat
 F = High gas heat
 S = Low heat with stainless steel exchanger
 R = Med heat with stainless steel exchanger
 T = High heat with stainless steel exchanger

Refrig. System Options

0 = Three-stage cooling capacity
 A = Three-stage cooling capacity control with Humidi-MiZer®

Cooling Tons

14 = 12.5 Ton
 17 = 15 Ton
 20 = 17.5 Ton
 24 = 20 Ton
 26 = 23 Ton

Sensor Options

A = None
 B = RA smoke detector
 C = SA smoke detector
 D = RA & SA smoke detector
 E = CO₂ sensor
 F = RA smoke detector & CO₂
 G = SA smoke detector & CO₂
 H = RA & SA smoke detector & CO₂

Indoor Fan Options & Indoor Fan Options

1 = Standard Static / Vertical Supply, Return Air Flow
 2 = Medium Static / Vertical Supply, Return Air Flow
 3 = High Static / Vertical Supply, Return Air Flow
 4 = Ultra High Static / Vertical Supply, Return Air Flow
 5 = Standard Static / Horizontal Supply, Return Air Flow
 6 = Medium Static / Horizontal Supply, Return Air Flow
 7 = High Static / Horizontal Supply, Return Air Flow
 8 = Ultra High Static / Horizontal Supply, Return Air Flow

Coil Options (Outdoor-Indoor-Hail Guard)

A = Al/Cu – Al/Cu
 B = Pre-coat Al/Cu – Al/Cu
 C = E coat Al/Cu – Al/Cu
 D = E coat Al/Cu – E coat Al/Cu
 E = Cu/Cu – Al/Cu
 F = Cu/Cu – Cu/Cu
 M = Al/Cu – Al/Cu – Louvered Hail Guard
 N = Pre-coat Al/Cu – Al/Cu – Louvered Hail Guard
 P = E-coat Al/Cu – Al/Cu – Louvered Hail Guard
 Q = E-coat Al/Cu – E-coat Al/Cu – Louvered Hail Guard
 R = Cu/Cu – Al/Cu – Louvered Hail Guard
 S = Cu/Cu – Cu/Cu – Louvered Hail Guard

Brand / Packaging

0 = Standard
 1 = LTL

Electrical Options

A = None
 B = HACR Breaker
 C = Non-fused disconnect

Service Options

0 = None
 1 = Unpowered convenience outlet
 2 = Powered convenience outlet
 3 = Hinged panels
 4 = Hinged panels, unprwd conv outlet
 5 = Hinged panels, prwd conv outlet

Air Intake / Exhaust Options

A = None
 B = Temp Standard Leak Econo w/Baro relief
 C = Temp Standard Leak Econo w/PE (cent) – Vertical Only
 E = Enthalpy Standard Leak Econo w/Baro relief
 F = Enthalpy Standard Leak Econo w/PE (cent) – Vertical Only
 N = Temp Ultra Low Leak temp econo w/Baro relief
 P = Temp Ultra Low Leak temp econo w/PE (cent) – Vertical Only
 R = Enthalpy Ultra low leak enthalpy econo w/Baro relief
 S = Enthalpy Ultra low leak econo w/PE (cent) – Vertical Only

Base Unit Controls

0 = Electro-Mechanical Control
 1 = RTU Open Protocol Controller
 4 = SystemVu™ Controller*

Design Rev

– Factory design revision

Voltage

1 = 575/3/60
 5 = 208–230/3/60
 6 = 460/3/60

* SystemVu controller is not available on units equipped with Standard Leak Economizers or Humidi-MiZer system.

Not all possible options can be displayed above – see Price Pages for more details.

Table 1 – FACTORY-INSTALLED OPTIONS AND FIELD-INSTALLED ACCESSORIES

CATEGORY	ITEM	FACTORY-INSTALLED OPTION	FIELD-INSTALLED ACCESSORY
Cabinet	Hinged access panels	X	
Coil Options	Cu/Cu indoor and/or outdoor coils	X	
	Pre-coated outdoor coils	X	
	Premium, E-coated outdoor coils	X	
Humidity Control	Humidi-MiZer [®] Adaptive Dehumidification System	X	X
Condenser Protection	Condenser coil hail guard (louvered design)	X	X
Controls	Thermostats, temperature sensors, and subbases		X
	Smoke detector (supply and/or return air)	X	X
	Horn/Strobe Annunciator ⁷		X
	Time Guard II compressor delay control circuit		X
	Phase Monitor		X
	SystemVu™ Controller ⁶	X	
Economizers & Outdoor Air Dampers	EconoMi\$er X for electromechanical controls, complies with FDD. (Standard and Ultra Low Leak air damper models) ⁵	X	X
	EconoMi\$er2 for DDC controls, complies with FDD. (Standard and Ultra Low Leak air damper models) ⁵	X	X
	Barometric relief ¹	X	X
	Power exhaust	X	X
Economizer Sensors & IAQ Devices	Single dry bulb temperature sensors ²	X	X
	Differential dry bulb temperature sensors ²		X
	Single enthalpy sensors ²	X	X
	Differential enthalpy sensors ²		X
	Wall or duct mounted CO ₂ sensor ²		X
	Unit mounted CO ₂ sensor ²	X	
Gas Heat	Propane conversion kit		X
	Stainless steel heat exchanger	X	
	High altitude conversion kit		X
	Flue Discharge Deflector		X
Indoor Motor & Drive	Multiple motor and drive packages	X	
Power Options	Convenience outlet (powered)	X	
	Convenience outlet (unpowered)	X	
	HACR circuit breaker ^{3,4}	X	
	Non-fused disconnect ⁴	X	
Roof Curbs	Roof curb 14-in (356 mm)		X
	Roof curb 24-in (610 mm)		X

NOTES:

- 1 Included with economizer.
- 2 Sensors used to optimize economizer performance.
- 3 On 575V applications, HACR breaker can only be used with WYE power distribution systems. Using on Delta power distribution systems is prohibited.
- 4 When selecting a factory installed HACR breaker or non-fused disconnect, note they are sized for the unit as ordered from the factory. The sizing of these do not accommodate any field items, such as power exhaust devices, etc.
- 5 FDD (Fault Detection and Diagnostic) capability per California Title 24 section 120.2.
- 6 SystemVu controller is not available on units equipped with Standard Leak Economizers or Humidi-MiZer system.
- 7 Requires a field-supplied 24V transformer for each application. See price pages for details.

FACTORY OPTIONS AND/OR ACCESSORIES

Economizer

Economizers can reduce operating costs. They bring in fresh, outside air for ventilation; and provide cool outside air to cool your building. This also is the preferred method of low ambient cooling. When coupled to CO₂ sensors, economizers can limit the ventilation air to only that amount required.

Economizers are available, installed and tested by the factory, with either enthalpy or temperature dry-bulb inputs. There are also models for electromechanical and direct digital controllers. Additional sensors are available as accessories to optimize the economizer.

Economizers include gravity controlled barometric relief that helps equalize building pressure and ambient air pressures. This can be a cost effective solution to prevent building pressurization. Economizers are available in Ultra Low Leak and standard low leak versions.

CO₂ Sensor

The CO₂ sensor works with the economizer to intake only the correct amount of outside air for ventilation. As occupants fill your building, the CO₂ sensor detects their presence through increasing CO₂ levels, and opens the economizer appropriately.

When the occupants leave, the CO₂ levels decrease, and the sensor appropriately closes the economizer. This intelligent control of the ventilation air, called Demand Controlled Ventilation (DCV) reduces the overall load on the rooftop, saving money.

Smoke Detectors

Trust the experts. Smoke detectors make your application safer and your job easier. Carrier smoke detectors immediately shut down the rooftop unit when smoke is detected. They are available, installed by the factory, for supply air, return air, or both.

Louvered Hail Guards

Sleek, louvered panels protect the condenser coil from hail damage, foreign objects, and incidental contact.

Convenience Outlet (powered or un-powered)

Reduce service and/or installation costs by including a convenience outlet in your specification. Carrier will install this service feature at our factory. Provides a convenient, 15 amp, 115v GFCI receptacle with “Wet in Use” cover. The “powered” option allows the installer to power the outlet from the line side of the disconnect or load side as required by code. The “unpowered” option is to be powered from a separate 115/120v power source.

Non-fused Disconnect

This OSHA-compliant, factory-installed, safety switch allows a service technician to locally secure power to the rooftop.

When selecting a factory-installed non-fused disconnect, note they are sized for unit as ordered from the factory. The sizing of these does not accommodate any power exhaust devices, etc.

Power Exhaust

Superior internal building pressure control. This field-installed accessory may eliminate the need for costly, external pressure control fans.

Time Guard II Control Circuit

This accessory protects your compressor by preventing short-cycling in the event of some other failure, prevents the compressor from restarting for 30 seconds after stopping. Not required if built into thermostat or building management system.

Hinged Access Panels

Allows access to unit's major components with specifically designed hinged access panels. Panels are: filter, control box, fan motor and compressor. Comes with quarter turn latches and lift tabs.

Propane Heating

Convert your gas heat rooftop from standard natural gas operation to Propane using this field-installed kit.

High Altitude Heating

High altitudes have less oxygen, which means heat exchangers need less fuel. The new gas orifices in this field-installed kit make the necessary adjustment for high altitude applications. They restore the optimal fuel to air mixture and maintain healthy combustion at altitudes above 2000 ft (610 m). Kits may not be required in all areas.

Flue Discharge Deflector

The flue discharge deflector is a useful accessory when flue gas recirculation is a concern. By venting the flue discharge upwards, the deflector minimizes the chance for a neighboring unit to intake the flue exhaust.

FACTORY OPTIONS AND/OR ACCESSORIES (cont.)

Optional Stainless Steel Heat Exchanger

The stainless steel heat exchanger option provides the tubular heat exchanger be made out of a minimum 20 gauge type 409 stainless steel for applications where the mixed air to the heat exchanger is expected to drop below 45°F (7°C). Stainless steel may be specified on applications where the presence of airborne contaminants require its use (applications such as paper mills) or in area with very high outdoor humidity that may result in severe condensation in the heat exchanger during cooling operation.

HACR Breaker

These manual reset devices provide overload and short circuit protection for the unit. Factory wired and mounted with the units with access cover to help provide environment protection.

When selecting a factory installed non-fused disconnect, note they are sized for unit as ordered from the factory. The sizing of these do not accommodate any power exhaust devices, etc.

On 575V applications, HACR breaker can only be used with WYE power distribution systems. Use on Delta power distribution systems is prohibited.

Alternate Motors and Drives

Some applications need larger horsepower motors, some need more airflow, and some need both. Regardless of the case, your Carrier expert has a factory-installed combination to meet your application. A wide selection of motors and pulleys (drives) are available, factory installed, to handle nearly any application.

Thru-the-Bottom Connections

Provisions for thru-the-bottom power connections are standard.

Thermostat

Due to the three-stage cooling capacity design of these units, a three-stage cooling thermostat is required for the unit to perform at listed operating efficiencies.

Carrier offers a Honeywell branded T7350D (3 Cool/3 Heat) Commercial Programmable Thermostat. This provides:

- 7-day programmable
- 65-day clock with holiday programming
- Automatic Daylight Saving Time adjustment
- Backlit display
- Changeover selections: automatic or manual
- Fan configurable: continuous or intermittent during occupied

Optional Humidi-MiZer[®] Adaptive Dehumidification System

Carrier's Humidi-MiZer adaptive dehumidification system is an all-inclusive factory installed option that can be ordered with any 48LC WeatherExpert[®] rooftop unit, except for units equipped with SystemVu[™] controls.

This system expands the envelope of operation of Carrier's WeatherExpert rooftop products to provide unprecedented flexibility to meet year round comfort conditions.

The Humidi-MiZer adaptive dehumidification system has a unique dual operational mode setting. The Humidi-MiZer system provides greater dehumidification of the occupied space by two modes of dehumidification operations in addition to its normal design cooling mode.

The 48LC WeatherExpert rooftop coupled with the Humidi-MiZer system is capable of operating in normal design cooling mode, subcooling mode, and hot gas reheat mode. Normal design cooling mode is when the unit will operate under its normal sequence of operation by cycling compressors to maintain comfort conditions.

Subcooling mode will operate to satisfy part load type conditions when the space requires combined sensible and a higher proportion of latent load control. Hot Gas Reheat mode will operate when outdoor temperatures diminish and the need for latent capacity is required for sole humidity control. Hot Gas Reheat mode will provide neutral air for maximum dehumidification operation.

FACTORY OPTIONS AND/OR ACCESSORIES (cont.)

SystemVu™ Controller

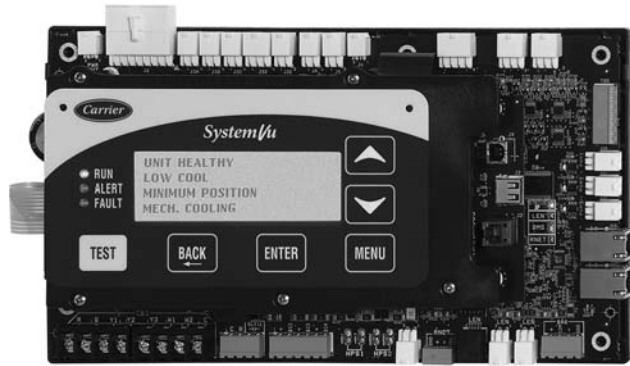

C150174



BACnet is a registered trademark of ASHRAE. ASHRAE does not endorse, approve or test products for compliance with ASHRAE standards. Compliance of listed products to the requirements of ASHRAE Standard 135 is the responsibility of BACnet International (BI). BTL is a registered trademark of BI.

Carrier's new SystemVu™ unit controller is an optional factory installed and tested controller designed specifically for use in the WeatherExpert® rooftop units.

This new controller takes on a whole new approach to provide an intuitive, intelligent controller that not only monitors and controls the unit, but also provides linkage to multiple building automation systems.

Each SystemVu controller makes it easy to set up, service, troubleshoot, gain historical data, generate reports and provide comfort only Carrier is noted for.

Some of the key features include:

- Easy to read back lit four line text screen for superior visibility.
- Quick operational condition LED's of: Run, Alert, and Fault.
- Simple navigation with large keypad buttons of: Navigation arrows, Test, Back, Enter and Menu.
- Capable of being controlled with a conventional thermostat, space sensor or building automation systems.
- Service Capabilities Include:
 - Auto run test
 - Manual run test
 - Component run hours and starts
 - Commissioning reports
 - Data logging
- Full Range of Diagnosis:
 - Read refrigerant pressures without the need of gauges
 - Sensor faults
 - Compressor reverse rotation
 - Economizer diagnostics that meets California Title 24 requirements
- Quick data transfer via USB port:
 - Unit configuration uploading/downloading
 - Data logging
 - Software upgrades
- Built in capability for:
 - i-Vu® open systems
 - BACnet* systems
 - CCN systems
- Configuration and alarms point capability
 - Contain over 100 alarm codes
 - Contain over 260 status, troubleshooting, diagnostic and maintenance points
 - Contain over 270 control configuration setpoints

NOTE: SystemVu controller is not available on units equipped with Standard Leak Economizers or Humidi-MiZer® system.

* BACnet is a registered trademark of ASHRAE (American Society of Heating, Refrigerating and Air-Conditioning Engineers)

Table 2 – AHRI COOLING RATING TABLE

208V — VERTICAL AIR FLOW

LC SIZE	COOLING STAGES	NOMINAL CAPACITY (Tons)	NET COOLING CAPACITY (MBH)	TOTAL POWER (kW)	INDOOR MOTOR OPTION (Static Capability)	EER	IEER
14	3	12.5	146.0	11.8	Std, High, Ultra High	12.4	19.1
				11.9	Med	12.3	18.9
17	3	15.0	172.0	13.8	Std, Med, High, Ultra High	12.5	18.4
20	3	17.5	192.0	16.0	Std, Med, High, Ultra High	12.0	17.7
24	3	20.0	230.0	19.2	Std, Med, High	12.0	18.0
26	3	23.0	272.0	24.5	Std, Med, High	11.1	17.8

Table 3 – AHRI COOLING RATING TABLE

230/460/575V — VERTICAL AIR FLOW

LC SIZE	COOLING STAGES	NOMINAL CAPACITY (Tons)	NET COOLING CAPACITY (MBH)	TOTAL POWER (kW)	INDOOR MOTOR OPTION (Static Capability)	EER	IEER
14	3	12.5	146.0	11.8	Std, High, Ultra High	12.4	19.1
				11.9	Med	12.3	18.9
17	3	15.0	174.0	13.9	Std, Med, High, Ultra High	12.5	18.4
20	3	17.5	194.0	16.2	Std, Med, High, Ultra High	12.0	17.5
24	3	20.0	232.0	19.3	Std, Med, High	12.0	18.0
26	3	23.0	272.0	24.5	Std, Med, High	11.1	17.8

Table 4 – AHRI COOLING RATING TABLE

208V — HORIZONTAL AIR FLOW

LC SIZE	COOLING STAGES	NOMINAL CAPACITY (Tons)	NET COOLING CAPACITY (MBH)	TOTAL POWER (kW)	INDOOR MOTOR OPTION (Static Capability)	EER	IEER
14	3	12.5	146.0	12.2	Std, High, Ultra High	12.0	18.3
				12.4	Med	11.8	18.1
17	3	15.0	170.0	14.4	Std, Med, High, Ultra High	11.8	17.2
20	3	17.5	190.0	17.0	Std, Med, High, Ultra High	11.2	16.8
24	3	20.0	228.0	20.8	Std, Med, High	10.9	17.1
26	3	23.0	266.0	26.3	Std, Med, High	10.1	16.1

Table 5 – AHRI COOLING RATING TABLE

230/460/575V — HORIZONTAL AIR FLOW

LC SIZE	COOLING STAGES	NOMINAL CAPACITY (Tons)	NET COOLING CAPACITY (MBH)	TOTAL POWER (kW)	INDOOR MOTOR OPTION (Static Capability)	EER	IEER
14	3	12.5	146.0	12.2	Std, High, Ultra High	12.0	18.3
				12.4	Med	11.8	18.1
17	3	15.0	172.0	14.6	Std, Med, High, Ultra High	11.8	17.2
20	3	17.5	192.0	17.1	Std, Med, High, Ultra High	11.2	16.6
24	3	20.0	230.0	21.0	Std, Med, High	10.9	17.1
26	3	23.0	266.0	26.3	Std, Med, High	10.1	16.1

LEGEND AND NOTES FOR TABLES 2 – 5

- AHRI – Air-Conditioning, Heating and Refrigeration Institute Test Standard
- ASHRAE – American Society of Heating, Refrigerating and Air-Conditioning Engineers
- EER – Energy Efficiency Ratio
- IEER – Integrated Energy Efficiency Ratio

NOTES:

- 1 Rated in accordance with AHRI Standards.
- 2 Ratings are based on:
Cooling Standard: 80°F (27°C) db, 67°F (19°C) wb indoor air temp and 95°F (35°C) db outdoor air temp.
- 3 48LC units comply with US Energy Policy Act. To evaluate code compliance requirements, refer to state and local codes.

Table 6 – HEATING RATING TABLE - NATURAL GAS & PROPANE

48LC	GAS HEAT	AL/SS HEAT EXCHANGER		TEMP RISE (DEG F)	THERMAL EFFICIENCY (%)
		INPUT / OUTPUT STAGE 1 (MBH)	INPUT / OUTPUT STAGE 2 (MBH)		
14	LOW	141 / 114	176 / 143	20 – 50	81%
	MED	176 / 142	220 / 178	20 – 55	81%
	HIGH	248 / 200	310 / 251	30 – 60	81%
17	LOW	176 / 142	220 / 178	20 – 55	81%
	MED	248 / 200	310 / 251	30 – 60	81%
	HIGH	320 / 260	400 / 324	35 – 65	81%
20	LOW	176 / 142	220 / 178	20 – 55	81%
	MED	248 / 200	310 / 251	30 – 60	81%
	HIGH	320 / 260	400 / 324	35 – 65	81%
24	LOW	176 / 142	220 / 178	20 – 55	81%
	MED	248 / 200	310 / 251	30 – 60	81%
	HIGH	320 / 260	400 / 324	35 – 65	81%
26	LOW	176 / 142	220 / 178	20 – 55	80%
	MED	248 / 200	310 / 251	30 – 60	81%
	HIGH	320 / 260	400 / 324	35 – 65	81%

NOTES:

- Heat ratings are for natural gas heat exchangers operated at or below 2000 ft (610 m). For information on Propane or altitudes above 2000 ft (610 m), see the Application Data section of this book. Accessory Propane/High Altitude kits are also available.
- In the USA the input rating for altitudes above 2000 ft (610 m) must be derated by 4% for each 1000 ft (305 m) above sea level.

Table 7 – SOUND PERFORMANCE TABLE

48LC	Cooling Stages	OUTDOOR SOUND (dB) AT 60 Hz									
		A-Weighted	31.5	63	125	250	500	1000	2000	4000	8000
14	3	84	92.6	92.2	83.9	80.4	81.8	78.7	76.5	72.2	65.4
17	3	86	101.3	97.1	88.3	84.4	83.3	80.7	77.4	73.4	67.3
20	3	86	101.3	97.1	88.3	84.4	83.3	80.7	77.4	73.4	67.3
24	3	86	101.3	97.1	88.3	84.4	83.3	80.7	77.4	73.4	67.3
26	3	86	101.3	97.1	88.3	84.4	83.3	80.7	77.4	73.4	67.3

LEGEND

dB – Decibel

NOTES:

- Outdoor sound data is measured in accordance with AHRI standard 270.
- Measurements are expressed in terms of sound power. Do not compare these values to sound pressure values because sound pressure depends on specific environmental factors which normally do not match individual applications. Sound power values are independent of the environment and therefore more accurate.
- A-weighted sound ratings filter out very high and very low frequencies, to better approximate the response of “average” human ear. A-weighted measurements for Carrier units are taken in accordance with AHRI standard 270.

Table 8 – COOLING MINIMUM - MAXIMUM AIRFLOW RATINGS

48LC	COOLING STAGE	MAX CFM	MIN CFM	MAX OD AMBIENT TEMP °F	MIN OD AMBIENT TEMP °F
14	Stage-3	6250	3150	125	40
	Stage-2	3750	1900		
	Stage-1	2500	1250		
17	Stage-3	7500	3750	125	40
	Stage-2	4500	2250		
	Stage-1	3000	1500		
20	Stage-3	8750	4400	125	40
	Stage-2	5400	2700		
	Stage-1	4600	2300		
24	Stage-3	10000	5000	125	40
	Stage-2	5700	2850		
	Stage-1	4300	2150		
26	Stage-3	11250	5650	125	40
	Stage-2	8100	4050		
	Stage-1	6750	3400		

NOTE: SystemVu™ controller provides minimum outdoor temperature operation down to 0°F (-18°C).

Table 9 – HEATING MINIMUM / MAXIMUM CFM TABLE - NATURAL GAS & PROPANE

48LC	GAS HEAT	MIN. AIRFLOW		MAX. AIRFLOW	
		CFM	CFM/TON	CFM	CFM/TON
14	LOW	2640	210	6600	530
	MED	3000	240	8250	660
	HIGH	3880	310	7750	620
17	LOW	3000	200	8250	550
	MED	3880	260	7750	520
	HIGH	4620	310	8570	570
20	LOW	3000	170	8250	470
	MED	3880	220	7750	440
	HIGH	4620	260	8570	490
24	LOW	3000	150	8250	410
	MED	3880	190	7750	390
	HIGH	4620	230	8570	430
26	LOW	2960	130	8150	350
	MED	3880	170	7750	340
	HIGH	4620	200	8570	370



Table 10 – PHYSICAL DATA

(COOLING)

12.5 - 23 TONS

	48LC**14	48LC**17	48LC**20	48LC**24	48LC**26	
Refrigeration System						
# Circuits / # Comp. / Type	1 / 2 / Scroll	1 / 2 / Scroll	1/2/Scroll	1 / 2 / Scroll	1 / 2 / Scroll	
RTPF models R-410A charge (lbs – oz)	32-0	33-6	35-6	40-10	43-4	
Alternate (Humidi-MiZer®) R-410A charge (lbs – oz)	40-0	50-7	49-0	57-7	54-0	
Metering device	TXV	TXV	TXV	TXV	TXV	
High–press. Trip / Reset (psig)	630 / 505	630 / 505	630 / 505	630 / 505	630 / 505	
Low–press. Trip / Reset (psig)	54 / 117	54 / 117	54 / 117	54 / 117	54 / 117	
Evap. Coil						
Material	Cu / Al	Cu / Al	Cu / Al	Cu / Al	Cu / Al	
Coil type	5/16" RTPF	5/16" RTPF	5/16" RTPF	5/16" RTPF	5/16" RTPF	
Coil Length (in)	72	72	72	72	72	
Coil Height (in)	44	52	52	52	52	
Rows / FPI	4 / 15	4 / 15	4 / 15	4 / 15	4 / 15	
total face area (ft ²)	22.0	26.0	26.0	26.0	26.0	
Condensate drain conn. size	3/4"	3/4"	3/4"	3/4"	3/4"	
Humidi-MiZer Coil						
Material	Cu / Al	Cu / Al	Cu / Al	Cu / Al	Cu / Al	
Coil type	5/16" RTPF	5/16" RTPF	5/16" RTPF	5/16" RTPF	5/16" RTPF	
Coil Length (in)	72	72	72	72	72	
Coil Height (in)	44	52	52	52	52	
Rows / FPI	1 / 18	1 / 18	2 / 18	3 / 18	4 / 18	
total face area (ft ²)	22	26	26	26	26	
Evap. fan and motor						
VERTICAL						
Standard Static	Motor Qty / Belt Qty / Driver Type	1 / 1 / Belt	1 / 1 / Belt	1 / 1 / Belt	1 / 1 / Belt	1 / 1 / Belt
	Max BHP	2.9	2.9	2.9	7.4	7.4
	RPM range	498-676	555-753	676-854	707-888	707-888
	motor frame size	56	56	56HZ	184T	184T
	Fan Qty / Type	2 / Centrifugal	2 / Centrifugal	2 / Centrifugal	2 / Centrifugal	2 / Centrifugal
	Fan Diameter (in)	15 x 15 / 15 X 15	15 x 15 / 15 X 15	15 x 15 / 15 X 15	15 x 15 / 15 X 15	15 x 15 / 15 X 15
Medium Static	Motor Qty / Belt Qty / Driver Type	1 / 1 / Belt	1 / 1 / Belt	1 / 1 / Belt	1 / 1 / Belt	1 / 1 / Belt
	Max BHP	4.9	7.4	7.4	9.9	9.9
	RPM range	682-861	707-888	782-963	872-1053	872-1053
	motor frame size	145TZ	184T	184T	213T	213T
	Fan Qty / Type	2 / Centrifugal	2 / Centrifugal	2 / Centrifugal	2 / Centrifugal	2 / Centrifugal
	Fan Diameter (in)	15 x 15 / 15 X 15	15 x 15 / 15 X 15	15 x 15 / 15 X 15	15 x 15 / 15 X 15	15 x 15 / 15 X 15
High Static	Motor Qty / Belt Qty / Driver Type	1 / 1 / Belt	1 / 1 / Belt	1 / 1 / Belt	1 / 2 / Belt	1 / 2 / Belt
	Max BHP	7.4	9.9	9.9	13.6	13.6
	RPM range	782-963	872-1053	933-1113	1049-1291	1049-1291
	motor frame size	184T	213T	213T	215T	215T
	Fan Qty / Type	2 / Centrifugal	2 / Centrifugal	2 / Centrifugal	2 / Centrifugal	2 / Centrifugal
	Fan Diameter (in)	15 x 15 / 15 X 15	15 x 15 / 15 X 15	15 x 15 / 15 X 15	15 x 15 / 15 X 15	15 x 15 / 15 X 15
Ultra High Static	Motor Qty / Belt Qty / Driver Type	1 / 1 / Belt	1 / 2 / Belt	1 / 2 / Belt	N/A	N/A
	Max BHP (208/230/460/575v)	9.9	13.6	13.6	N/A	N/A
	RPM range	933-1113	1049-1291	1049-1291	N/A	N/A
	motor frame size	213T	215T	215T	N/A	N/A
	Fan Qty / Type	2 / Centrifugal	2 / Centrifugal	2 / Centrifugal	N/A	N/A
	Fan Diameter (in)	15 x 15 / 15 X 15	15 x 15 / 15 X 15	15 x 15 / 15 X 15	N/A	N/A

Table 10 (cont.) - PHYSICAL DATA

(COOLING)

12.5 - 23 TONS

		48LC**14	48LC**17	48LC**20	48LC**24	48LC**26
Horizontal						
Standard Static	Motor Qty / Belt Qty / Driver Type	1 / 1 / Belt	1 / 1 / Belt	1 / 1 / Belt	1 / 1 / Belt	1 / 1 / Belt
	Max BHP	2.9	2.9	2.9	7.4	7.4
	RPM range	498-676	525-713	555-753	707-888	707-888
	motor frame size	56	56	56HZ	184T	184T
	Fan Qty / Type	2 / Centrifugal	2 / Centrifugal	2 / Centrifugal	2 / Centrifugal	2 / Centrifugal
	Fan Diameter (in)	18 x 15 / 15 X 11	18 x 15 / 15 X 11	18 x 15 / 15 X 11	18 x 15 / 15 X 11	18 x 15 / 15 X 11
Medium Static	Motor Qty / Belt Qty / Driver Type	1 / 1 / Belt	1 / 1 / Belt	1 / 1 / Belt	1 / 1 / Belt	1 / 1 / Belt
	Max BHP	4.9	7.4	7.4	9.9	9.9
	RPM range	644-808	707-888	707-888	859-1026	859-1026
	motor frame size	145TZ	184T	184T	213T	213T
	Fan Qty / Type	2 / Centrifugal	2 / Centrifugal	2 / Centrifugal	2 / Centrifugal	2 / Centrifugal
	Fan Diameter (in)	18 x 15 / 15 X 11	18 x 15 / 15 X 11	18 x 15 / 15 X 11	18 x 15 / 15 X 11	18 x 15 / 15 X 11
High Static	Motor Qty / Belt Qty / Driver Type	1 / 1 / Belt	1 / 1 / Belt	1 / 1 / Belt	1 / 2 / Belt	1 / 2 / Belt
	Max BHP	7.4	9.9	9.9	13.6	13.6
	RPM range	782-963	872-1053	872-1053	948-1190	948-1190
	motor frame size	184T	213T	213T	215T	215T
	Fan Qty / Type	2 / Centrifugal	2 / Centrifugal	2 / Centrifugal	2 / Centrifugal	2 / Centrifugal
	Fan Diameter (in)	18 x 15 / 15 X 11	18 x 15 / 15 X 11	18 x 15 / 15 X 11	18 x 15 / 15 X 11	18 x 15 / 15 X 11
Ultra High Static	Motor Qty / Belt Qty / Driver Type	1 / 1 / Belt	1 / 2 / Belt	1 / 2 / Belt	N/A	N/A
	Max BHP (208/230/460/575v)	9.9	13.6	13.6	N/A	N/A
	RPM range	933-1113	948-1190	948-1190	N/A	N/A
	motor frame size	213T	215T	215T	N/A	N/A
	Fan Qty / Type	2 / Centrifugal	2 / Centrifugal	2 / Centrifugal	N/A	N/A
	Fan Diameter (in)	18 x 15 / 15 X 11	18 x 15 / 15 X 11	18 x 15 / 15 X 11	N/A	N/A
Cond. Coil 1						
	Material	Cu / Al	Cu / Al	Cu / Al	Cu / Al	Cu / Al
	Coil type	5/16" RTPF	5/16" RTPF	5/16" RTPF	5/16" RTPF	5/16" RTPF
	Coil Length (in)	68	82	82	98	98
	Coil Height (in)	44	52	52	52	52
	Rows / FPI	2 / 18	2 / 18	2 / 18	2 / 18	2 / 18
	total face area (ft2)	20.8	29.6	29.6	35.4	35.4
Cond. Coil 2						
	Material	Cu / Al	Cu / Al	Cu / Al	Cu / Al	Cu / Al
	Coil type	5/16" RTPF	5/16" RTPF	5/16" RTPF	5/16" RTPF	5/16" RTPF
	Coil Length (in)	68	82	82	98	98
	Coil Height (in)	44	52	52	52	52
	Rows / FPI	2 / 18	2 / 18	2 / 18	2 / 18	2 / 18
	total face area (ft2)	20.8	29.6	29.6	35.4	35.4
Cond. fan / motor						
	Qty / Motor drive type	3 / direct	4 / direct	4 / direct	6 / direct	6 / direct
	Motor HP / RPM	1/3 / 1000	1/3 / 1000	1/3 / 1000	1/3 / 1000	1/3 / 1000
	Fan diameter (in)	22	22	22	22	22
Filters						
	RA Filter # / size (in)	6 / 20 x 25 x 2	9 / 16 x 25 x 2	9 / 16 x 25 x 2	9 / 16 x 25 x 2	9 / 16 x 25 x 2
	OA inlet screen # / size (in)	4 / 16 x 25 x 1	4 / 16 x 25 x 1	4 / 16 x 25 x 1	4 / 16 x 25 x 1	4 / 16 x 25 x 1

Table 11 – PHYSICAL DATA

(HEATING)

12.5 - 23 TONS

	48LC**14	48LC**17	48LC**20	48LC**24	48LC**26
Gas Connection					
# of Gas Valves	1	1	1	1	1
Nat. gas supply line press (in. w.g.) / (PSIG)	4 – 13 / 0.18 – 0.47	4 – 13 / 0.18 – 0.47	4 – 13 / 0.18 – 0.47	4 – 13 / 0.18 – 0.47	4 – 13 / 0.18 – 0.47
LP supply line press (in. w.g.) / (PSIG)	11 – 13 / 0.40 – 0.47	11 – 13 / 0.40 – 0.47	11 – 13 / 0.40 – 0.47	11 – 13 / 0.40 – 0.47	11 – 13 / 0.40 – 0.47
Heat Anticipator setting (Amps)					
1st stage	0.14	0.14	0.14	0.14	0.14
2nd stage	0.14	0.14	0.14	0.14	0.14
Natural Gas Heat					
# of stages / # of burners (total)	1 or 2 / 4	1 or 2 / 5	1 or 2 / 5	1 or 2 / 5	1 or 2 / 5
LOW Connection Size	3/4" NPT	3/4" NPT	3/4" NPT	3/4" NPT	3/4" NPT
Rollout switch opens / closes (F)	195 / 115	195 / 115	195 / 115	195 / 115	195 / 115
Temperature Rise (F)	20 – 50	20 – 55	20 – 55	20 – 55	20 – 55
# of stages / # of burners (total)	1 or 2 / 5	1 or 2 / 7	1 or 2 / 7	1 or 2 / 7	1 or 2 / 7
MED Connection Size	3/4" NPT	3/4" NPT	3/4" NPT	3/4" NPT	3/4" NPT
Rollout switch opens / closes (F)	195 / 115	195 / 115	195 / 115	195 / 115	195 / 115
Temperature Rise (F)	20 – 55	30 – 60	30 – 60	30 – 60	30 – 60
# of stages / # of burners (total)	1 or 2 / 7	1 or 2 / 9	1 or 2 / 9	1 or 2 / 9	1 or 2 / 9
HIGH Connection Size	3/4" NPT	3/4" NPT	3/4" NPT	3/4" NPT	3/4" NPT
Rollout switch opens / closes (F)	195 / 115	195 / 115	195 / 115	195 / 115	195 / 115
Temperature Rise (F)	30 – 60	35 – 65	35 – 65	35 – 65	35 – 65
Liquid Propane Heat					
# of stages / # of burners (total)	1 or 2 / 4	1 or 2 / 5	1 or 2 / 5	1 or 2 / 5	1 or 2 / 5
LOW Connection Size	3/4" NPT	3/4" NPT	3/4" NPT	3/4" NPT	3/4" NPT
Rollout switch opens / closes (F)	195 / 115	195 / 115	195 / 115	195 / 115	195 / 115
Temperature Rise (F)	20 – 50	20 – 55	20 – 55	20 – 55	20 – 55
# of stages / # of burners (total)	1 or 2 / 5	1 or 2 / 7	1 or 2 / 7	1 or 2 / 7	1 or 2 / 7
MED Connection Size	3/4" NPT	3/4" NPT	3/4" NPT	3/4" NPT	3/4" NPT
Rollout switch opens / closes (F)	195 / 115	195 / 115	195 / 115	195 / 115	195 / 115
Temperature Rise (F)	20 – 55	30 – 60	30 – 60	30 – 60	30 – 60
# of stages / # of burners (total)	1 or 2 / 7	1 or 2 / 9	1 or 2 / 9	1 or 2 / 9	1 or 2 / 9
HIGH Connection Size	3/4" NPT	3/4" NPT	3/4" NPT	3/4" NPT	3/4" NPT
Rollout switch opens / closes (F)	195 / 115	195 / 115	195 / 115	195 / 115	195 / 115
Temperature Rise (F)	30 – 60	35 – 65	35 – 65	35 – 65	35 – 65

UNIT: DIMENSIONS, WEIGHTS & CURBS

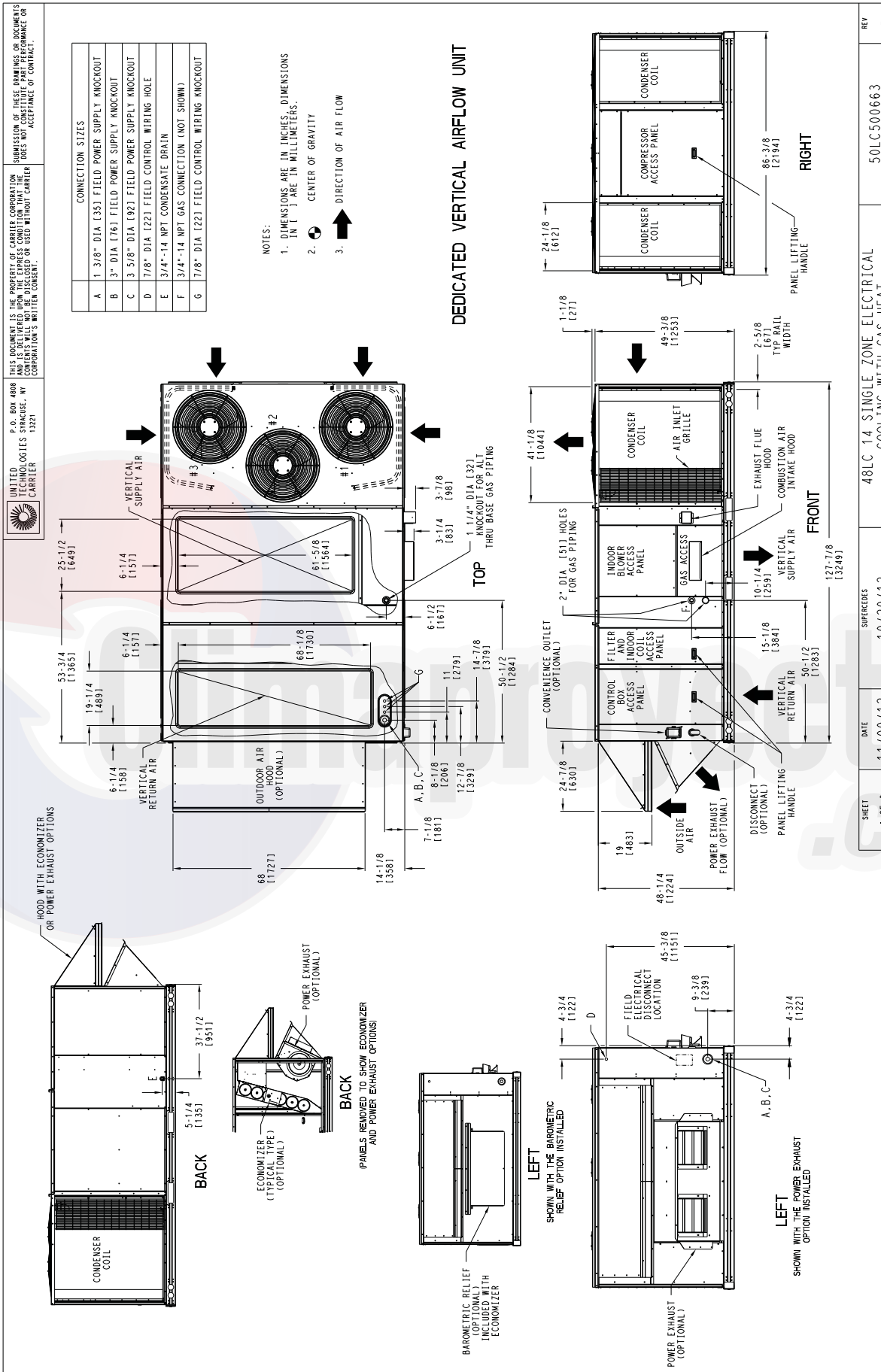

BACK

HOOD WITH ECONOMIZER OR POWER EXHAUST OPTIONS

ECONOMIZER (TYPICAL TYPE) (OPTIONAL)

POWER EXHAUST (OPTIONAL)

PANELS REMOVED TO SHOW ECONOMIZER AND POWER EXHAUST OPTIONS

LEFT

BAROMETRIC RELIEF (OPTIONAL) INCLUDED WITH ECONOMIZER

SHOWN WITH THE BAROMETRIC RELIEF OPTION INSTALLED

FRONT

INDOOR BLOWER ACCESS PANEL

CONTROL BOX ACCESS PANEL

FILTER AND INDOOR ACCESS PANEL

CONVENIENCE OUTLET (OPTIONAL)

2" DIA [51] HOLES FOR GAS PIPING

CONDENSER COIL

AIR INLET GRILLE

EXHAUST FLUE HOOD

COMBUSTION AIR INTAKE HOOD

2-5/8" [67] TIP RAIL WIDTH

1-1/8" [27] TIP RAIL WIDTH

48-3/8" [1253] TIP RAIL WIDTH

10-1/4" [259] TIP RAIL WIDTH

15-1/8" [384] TIP RAIL WIDTH

50-1/2" [1283] TIP RAIL WIDTH

127-7/8" [3249] TIP RAIL WIDTH

19" [483] TIP RAIL WIDTH

48-1/4" [1224] TIP RAIL WIDTH

24-7/8" [630] TIP RAIL WIDTH

41-1/8" [1044] TIP RAIL WIDTH

7-1/8" [181] TIP RAIL WIDTH

8-1/8" [206] TIP RAIL WIDTH

12-7/8" [329] TIP RAIL WIDTH

14-7/8" [379] TIP RAIL WIDTH

50-1/2" [1284] TIP RAIL WIDTH

6-1/4" [158] TIP RAIL WIDTH

19-1/4" [489] TIP RAIL WIDTH

53-3/4" [1365] TIP RAIL WIDTH

25-1/2" [649] TIP RAIL WIDTH

6-1/4" [157] TIP RAIL WIDTH

6-1/4" [157] TIP RAIL WIDTH

68-1/8" [1730] TIP RAIL WIDTH

11" [279] TIP RAIL WIDTH

14-7/8" [379] TIP RAIL WIDTH

3-1/4" [83] TIP RAIL WIDTH

3-7/8" [96] TIP RAIL WIDTH

1-1/8" [27] TIP RAIL WIDTH

48-3/8" [1253] TIP RAIL WIDTH

2-5/8" [67] TIP RAIL WIDTH

10-1/4" [259] TIP RAIL WIDTH

15-1/8" [384] TIP RAIL WIDTH

50-1/2" [1283] TIP RAIL WIDTH

127-7/8" [3249] TIP RAIL WIDTH

SHEET 1 OF 3

DATE 11/09/12

SUPERCEDS 10/29/12

48LC 14 SINGLE ZONE ELECTRICAL COOLING WITH GAS HEAT

REV 50LC500663

Fig. 1 - Dimensions 48LC 14

UNIT: DIMENSIONS, WEIGHTS & CURBS (cont.)

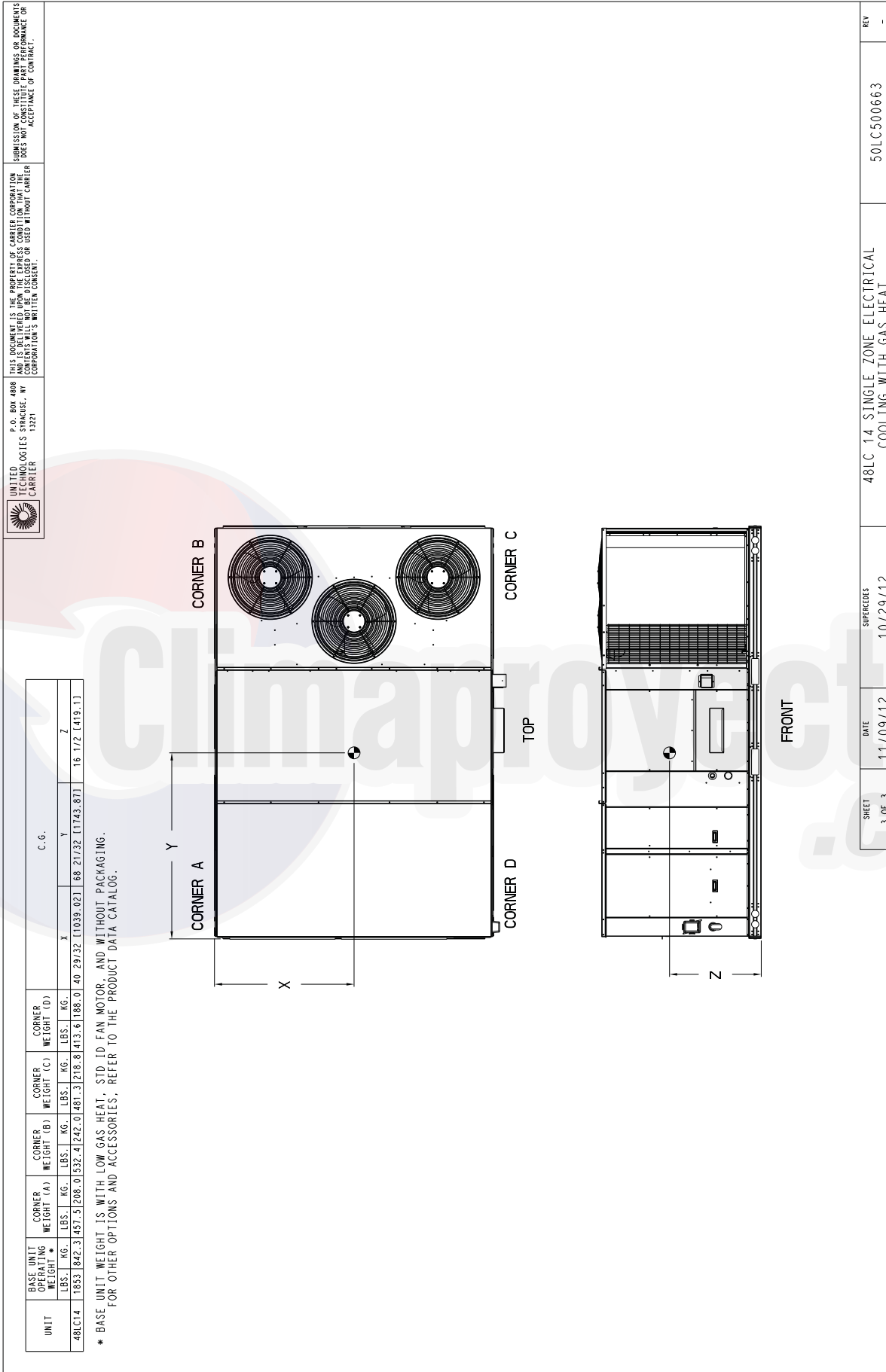

SHEET	DATE	SUPERCEDES	REV
3 OF 3	11/09/12	10/29/12	-
48LC 14 SINGLE ZONE ELECTRICAL COOLING WITH GAS HEAT		50LC500663	

Fig. 3 - Dimensions 48LC 14

UNIT: DIMENSIONS, WEIGHTS & CURBS (cont.)

UNIT SIZE	"A"	ROOF CURB ACCESSORY
14	1'-2" [356.0] 2'-0" [610.0]	CRRFCURB045A00 CRRFCURB046A00

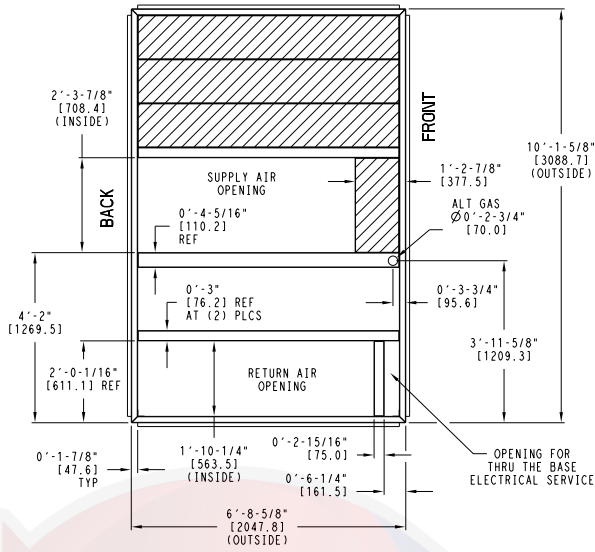

NOTES:

- 1 ROOF CURB ACCESSORY IS SHIPPED UNASSEMBLED.
- 2 DIMENSIONS IN () ARE IN MILLIMETERS.
- 3 ROOF CURB GALVANIZED STEEL.
- 4 ATTACH DUCTWORK TO CURB (FLANGES ON DUCT REST ON CURB)
- 5 SERVICE CLEARANCE 4 ft ON EACH SIDE

➔ DIRECTION OF AIR FLOW

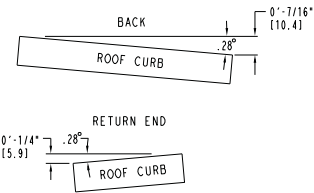

MAX CURB LEVELING TOLERANCES

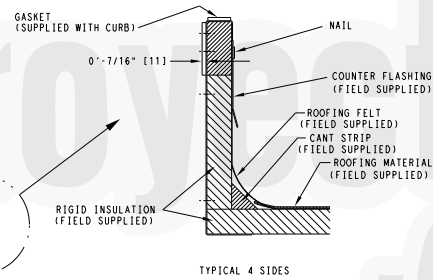
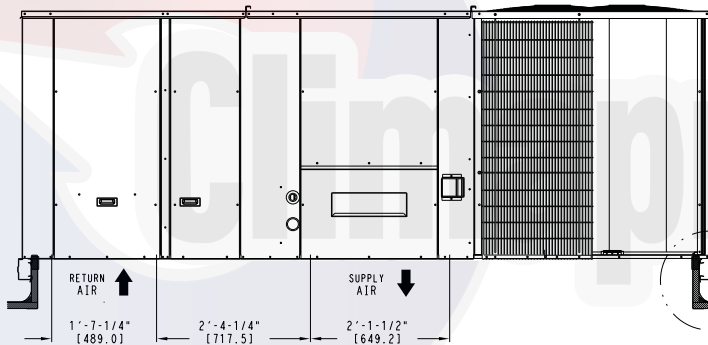

TYPICAL 4 SIDES

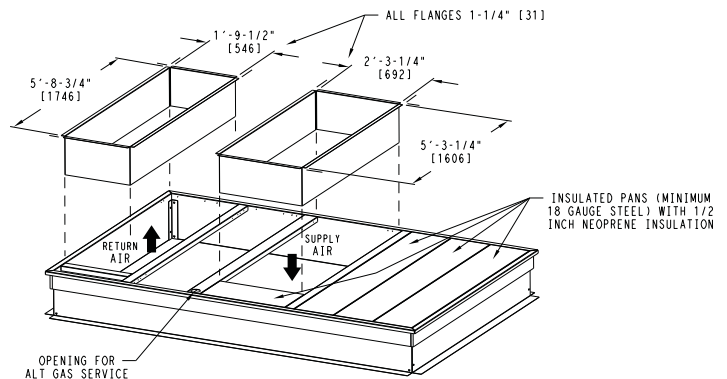
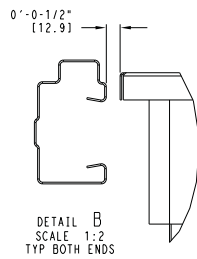
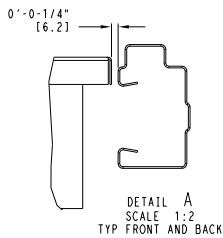
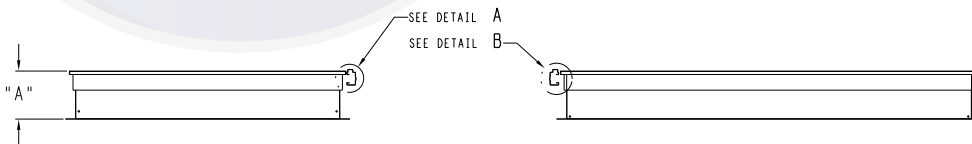

Fig. 4 - Roof Curb Details - Size 14 Units

UNIT: DIMENSIONS, WEIGHTS & CURBS (cont.)

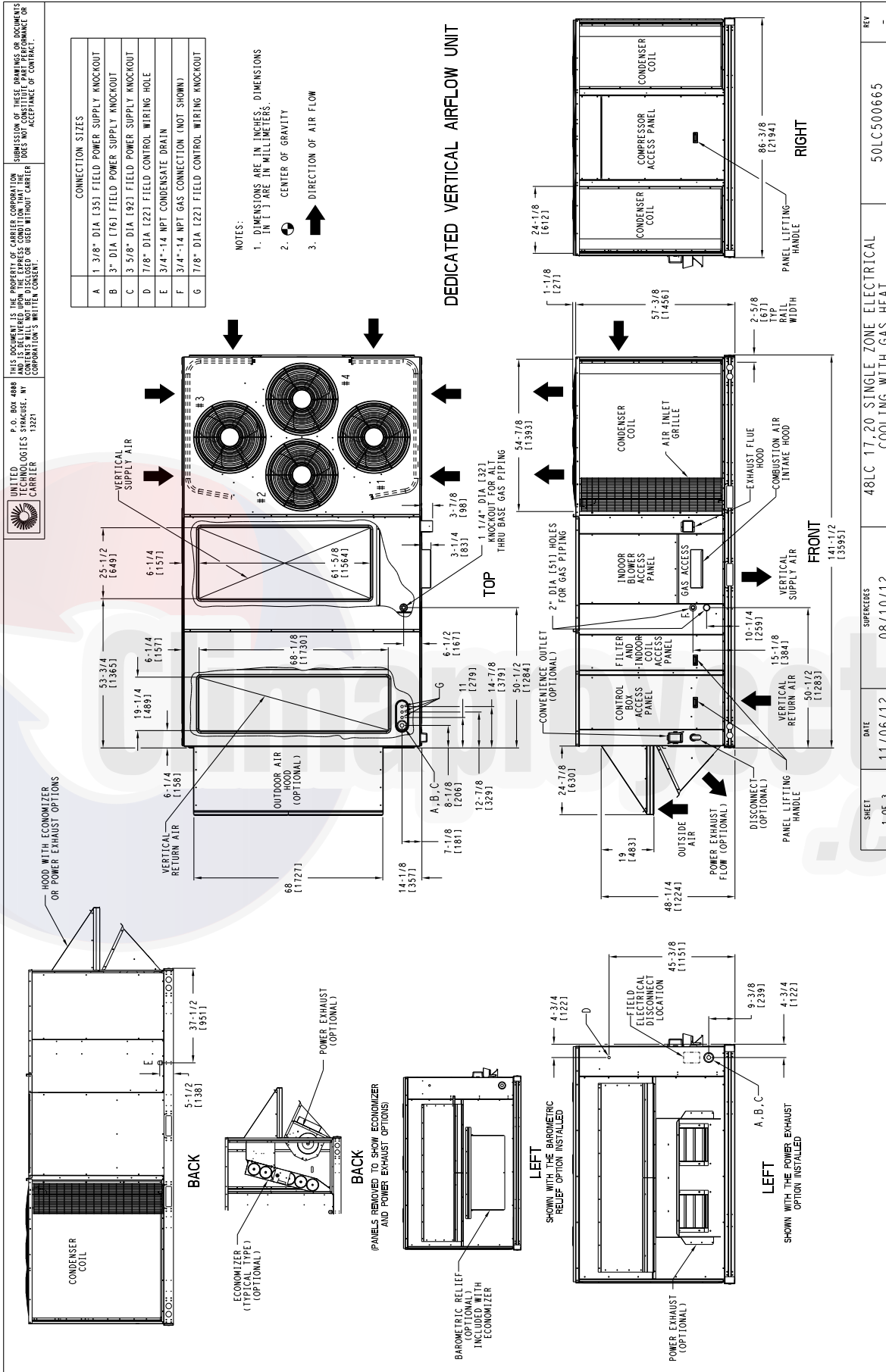
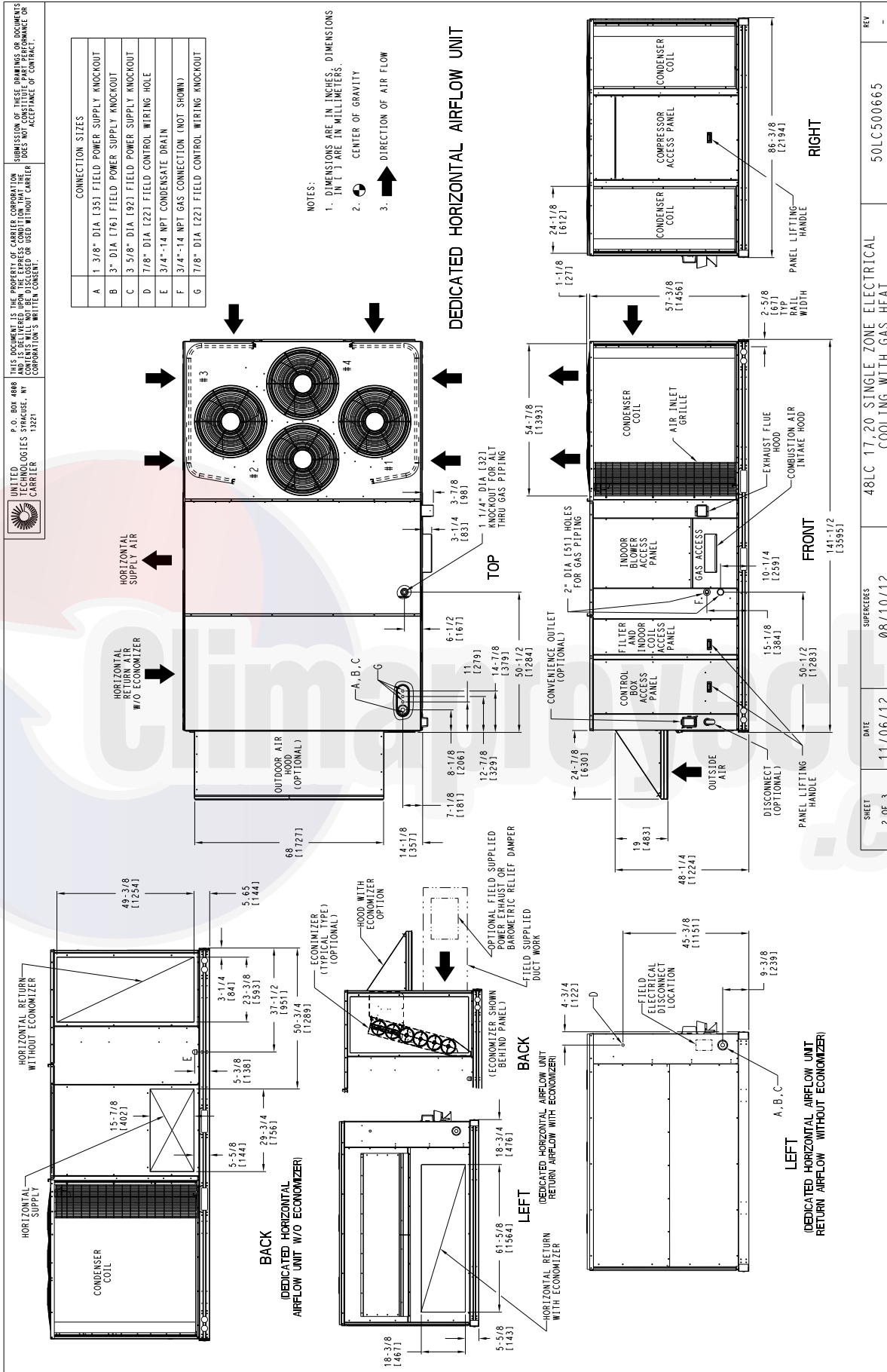

Fig. 5 - Dimensions 48LC 17, 20

UNIT: DIMENSIONS, WEIGHTS & CURBS (cont.)



SHEET 2 OF 3

DATE 11/06/12

SUPERCEDES 08/10/12

REV -

Fig. 6 - Dimensions 48LC 17, 20

UNIT: DIMENSIONS, WEIGHTS & CURBS (cont.)

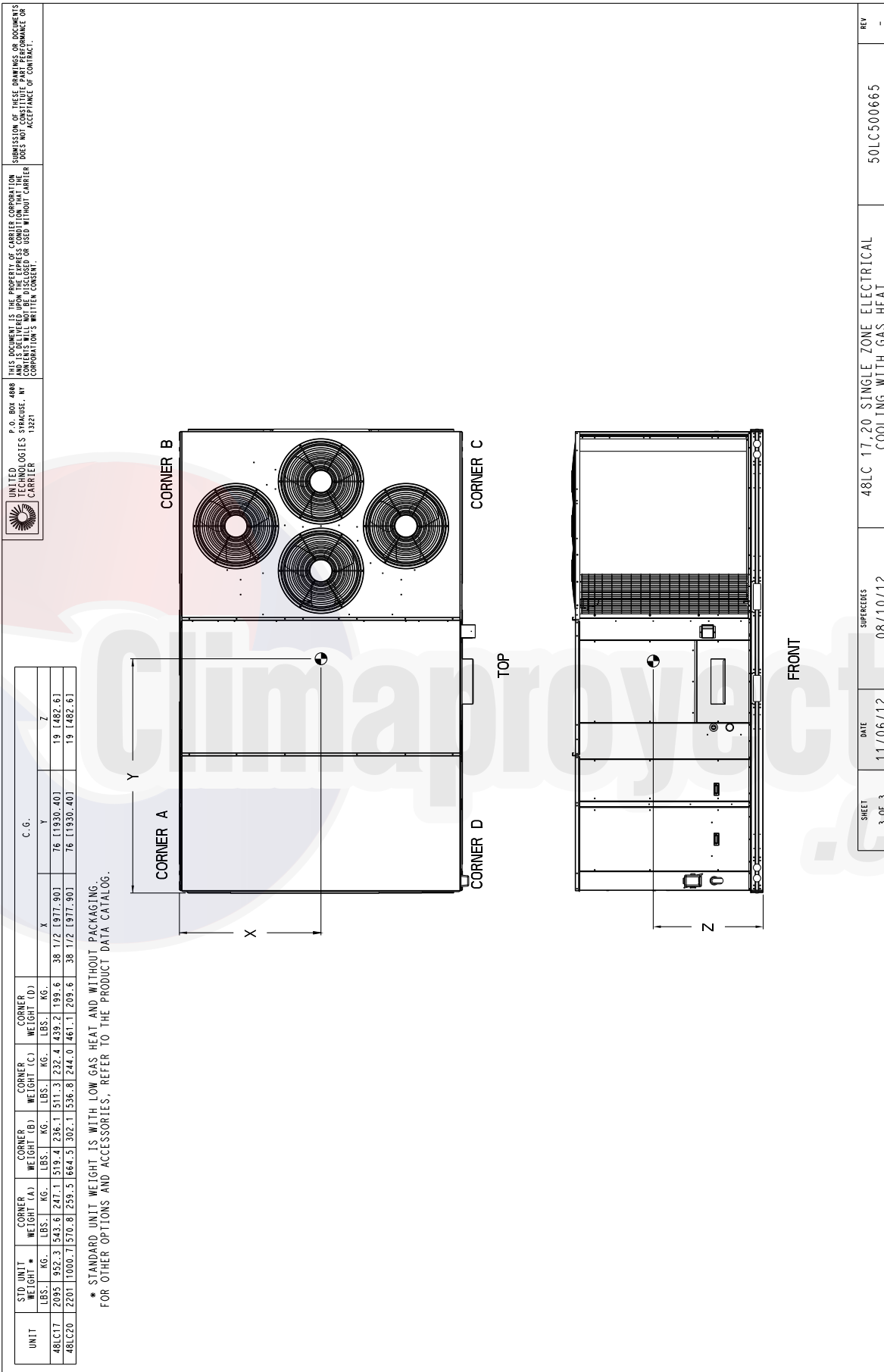
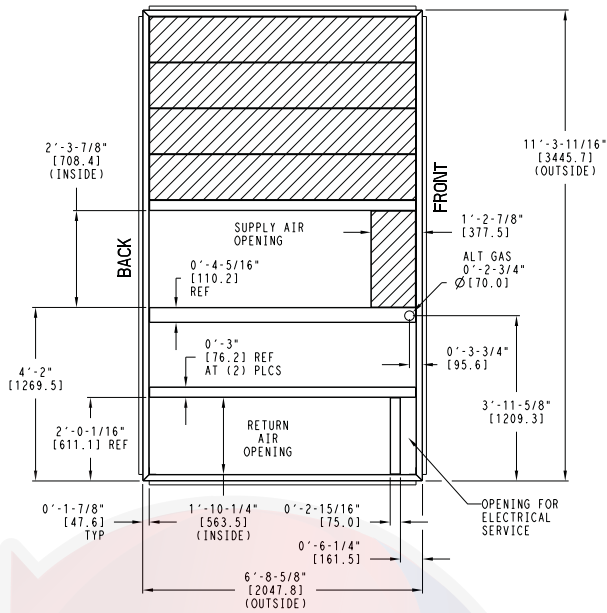

Fig. 7 - Dimensions 48LC 17, 20

UNIT: DIMENSIONS, WEIGHTS & CURBS (cont.)

UNIT SIZE	"A"	ROOF CURB ACCESSORY
17, 20	1'-2" [356.0] 2'-0" [610.0]	CRRFCURB047A00 CRRFCURB048A00



- NOTES:
- 1 ROOF CURB ACCESSORY IS SHIPPED UNASSEMBLED.
 - 2 DIMENSIONS IN [] ARE IN MILLIMETERS.
 - 3 ROOF CURB GALVANIZED STEEL.
 - 4 ATTACH DUCTWORK TO CURB (FLANGES ON DUCT REST ON CURB)
 - 5 SERVICE CLEARANCE 4 FT ON EACH SIDE

➔ DIRECTION OF AIR FLOW

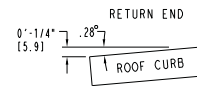
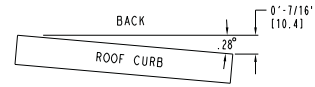

MAX CURB LEVELING TOLERANCES

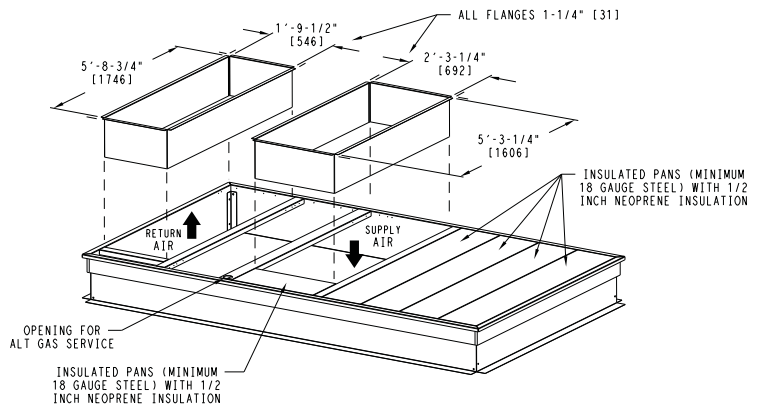
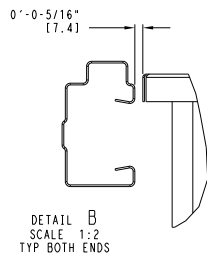
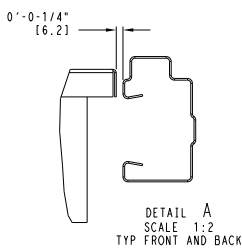
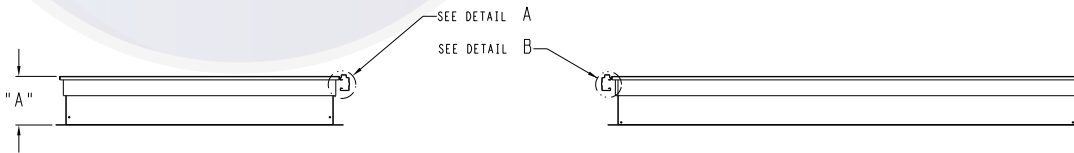
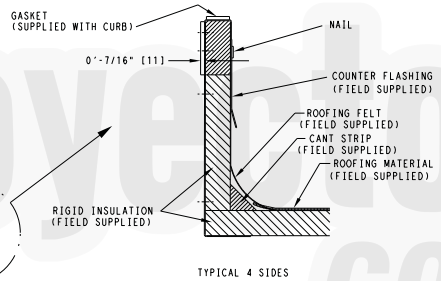
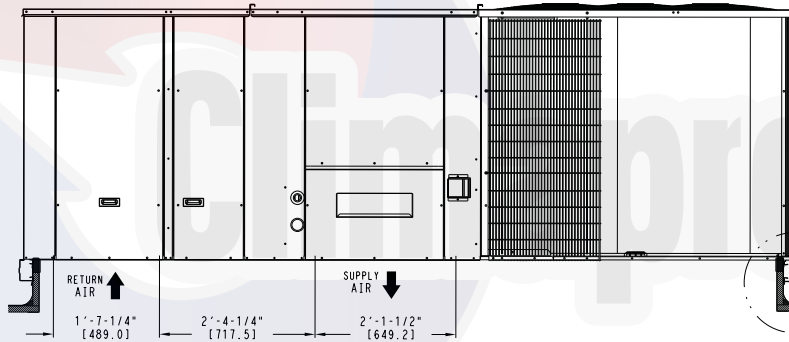

Fig. 8 - Roof Curb Details Size 17, 20 Units

C13055

UNIT: DIMENSIONS, WEIGHTS & CURBS (cont.)

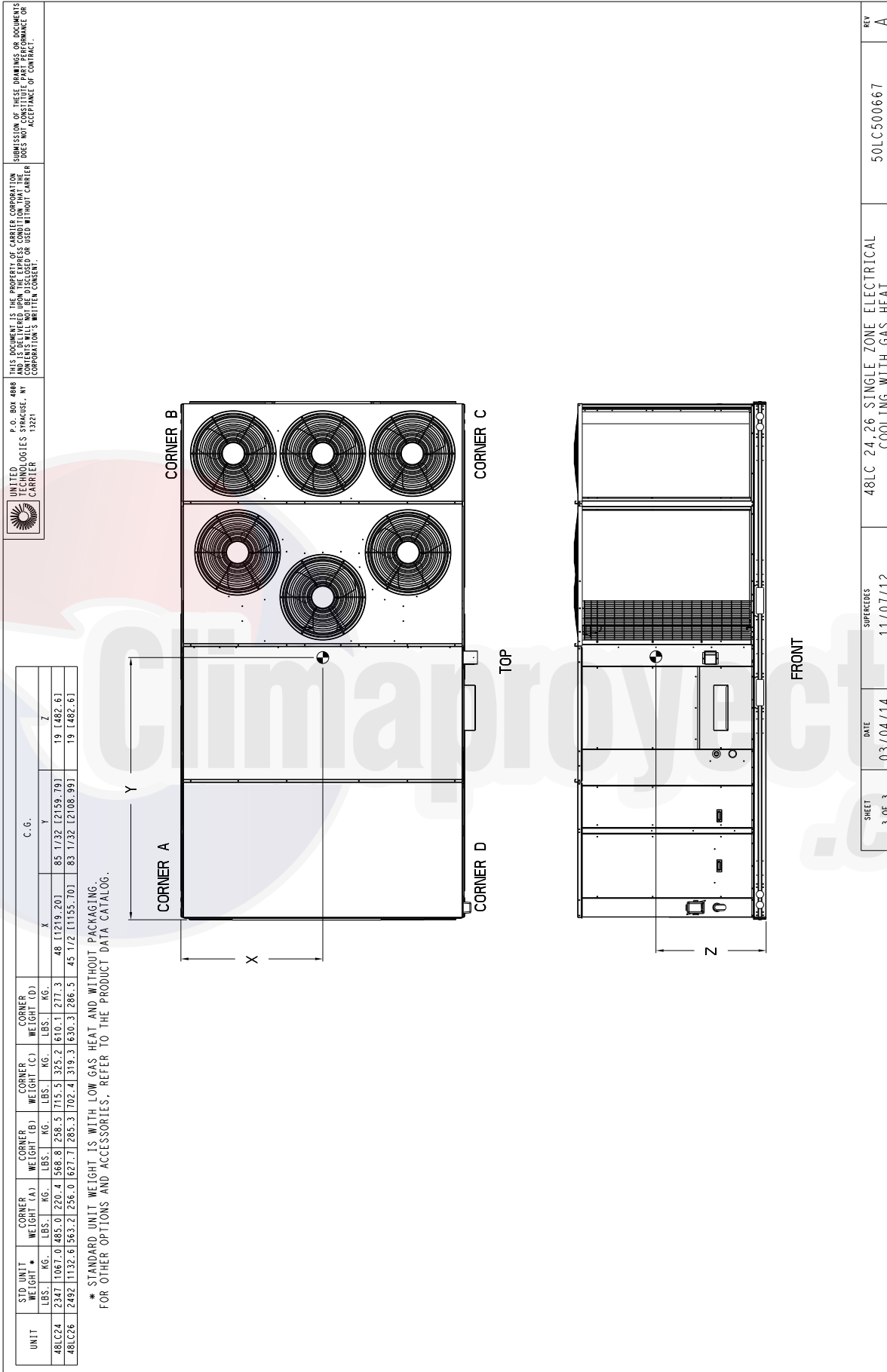
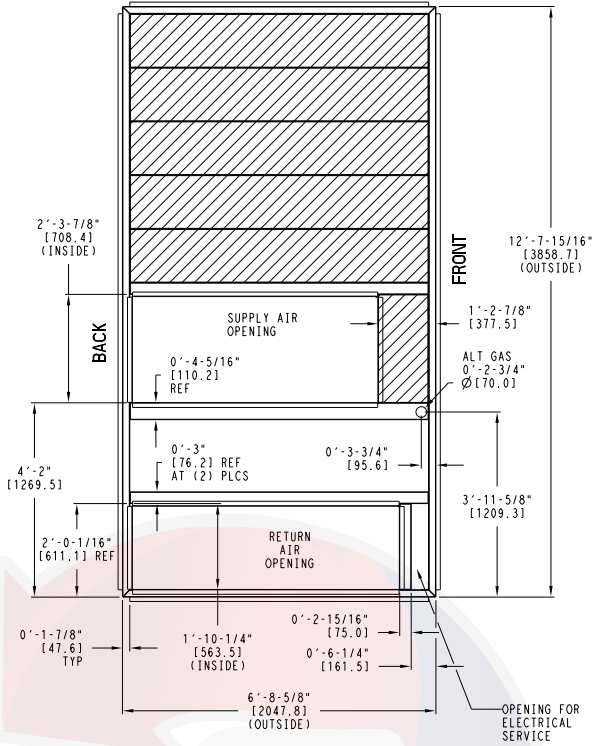

Fig. 11 - Dimensions 48LC 24, 26

UNIT: DIMENSIONS, WEIGHTS & CURBS (cont.)

UNIT SIZE	"A"	ROOF CURB ACCESSORY
24, 26	1'-2" [356.0] 2'-0" [610.0]	CRRFCURB049A00 CRRFCURB050A00



- NOTES:
- 1 ROOF CURB ACCESSORY IS SHIPPED UNASSEMBLED.
 - 2 BOLT HEADS TO BE ON INSIDE OF FLANGE. CLEARANCE IS (11) 0-0-7/16" TYP ALL CORNERS.
 - 3 DIMENSIONS IN () ARE IN MILLIMETERS.
 - 4 ROOF CURB GALVANIZED STEEL.
 - 5 ATTACH DUCTWORK TO CURB (FLANGES ON DUCT REST ON CURB)
 - 6 SERVICE CLEARANCE 4 FT ON EACH SIDE
 - 7 GAS SERVICE PLATE IS PART OF A SEPARATELY SHIPPED ACCESSORY PACKAGE.
 - 8 GAS SERVICE PLATE CAN BE USED WITH EITHER ACCESSORY ROOFCURB.

➔ DIRECTION OF AIR FLOW

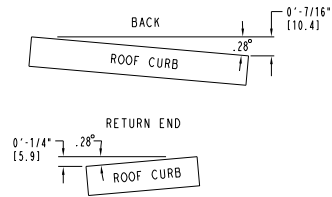

MAX CURB LEVELING TOLERANCES

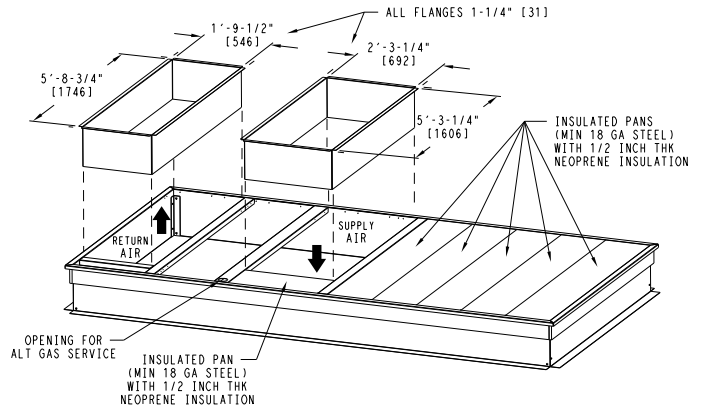
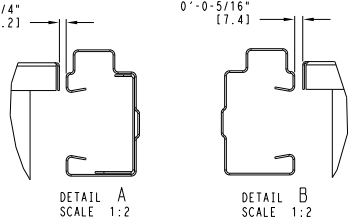
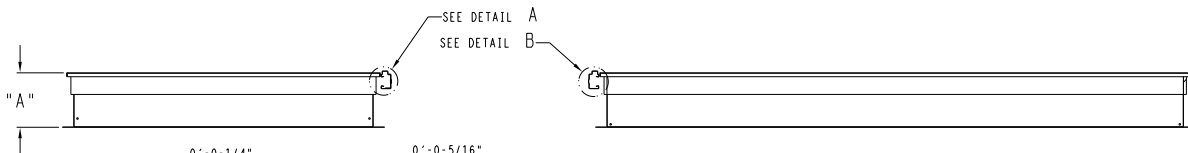
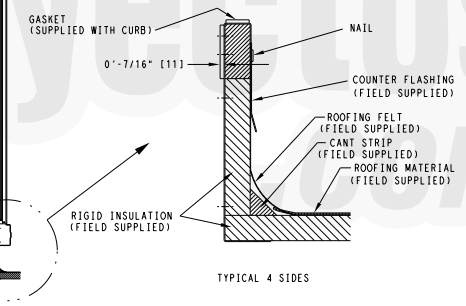
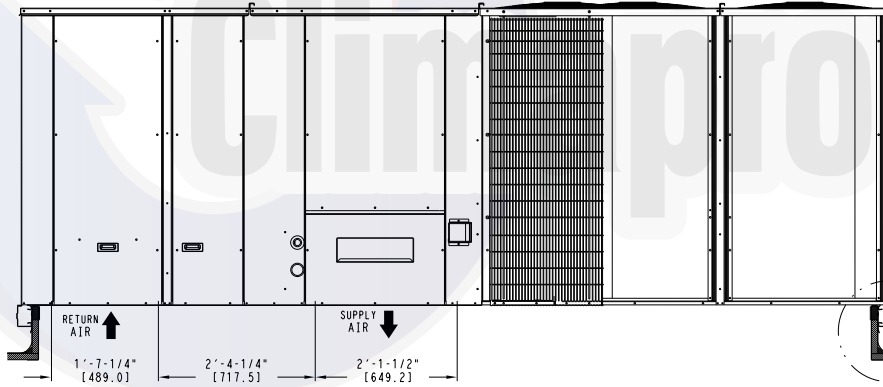
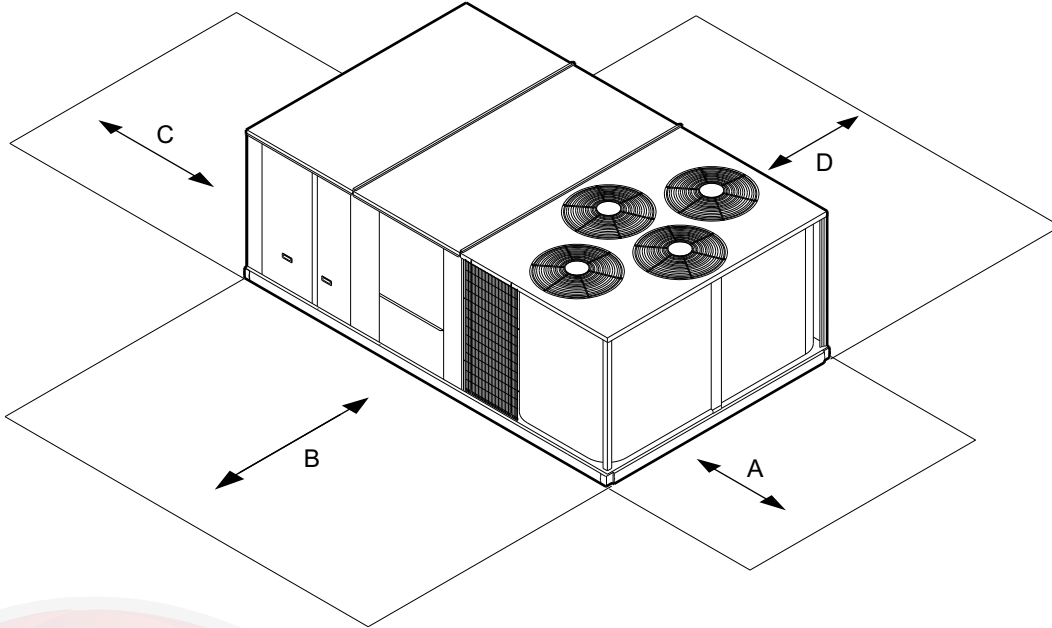

Fig. 12 - Roof Curb Details - Size 24, 26 Units

C13056

UNIT: DIMENSIONS, WEIGHTS & CURBS (cont.)



C13292

LOCATION	DIMENSION	CONDITION
A	36-in (914 mm)	<ul style="list-style-type: none"> Recommended clearance for air flow and service
B	42-in (1067 mm)	<ul style="list-style-type: none"> Recommended clearance for air flow and service
C	18-in (457 mm)	<ul style="list-style-type: none"> No Convenience Outlet No Economizer No field installed disconnect on economizer hood side (Factory-installed disconnect installed).
	36-in (914 mm)	<ul style="list-style-type: none"> Convenience Outlet installed. Vertical surface behind servicer is electrically non-conductive (e.g.: wood, fiberglass).
	42-in (1067 mm)	<ul style="list-style-type: none"> Convenience Outlet installed. Vertical surface behind servicer is electrically conductive (e.g.: metal, masonry).
C	96-in (2438 mm)	<ul style="list-style-type: none"> Economizer and/or Power Exhaust installed. Check for sources of flue products with 10 feet (3 meters) of economizer fresh air intake.
	42-in (1067 mm)	<ul style="list-style-type: none"> Recommended clearance for service.

NOTE: 1. Unit not designed to have overhead obstruction. Contact Application Engineering for guidance on any application planning overhead obstruction or for vertical clearances.

2. The number of fans varies with the unit size. Depending on size unit will have three to six fans.

Fig. 13 - Service Clearance Dimensional Drawing — Typical All 48LC 14-26 Units

OPTIONS & ACCESSORY WEIGHTS

OPTION / ACCESSORY	WEIGHT in LBS				
	48LC**14	48LC**17	48LC**20	48LC**24	48LC**26
Humidi-MiZer®	120	120	120	120	120
Medium Gas Heat	90	90	90	90	90
High Gas Heat	113	113	113	113	113
Medium Heat w/ Stainless Steel Exchanger	90	90	90	90	90
High Heat w/ Stainless Steel Exchanger	113	113	113	113	113
Return Smoke Detector	5	5	5	5	5
Supply Smoke Detector	5	5	5	5	5
RA & SA Smoke Detector	10	10	10	10	10
CO ₂ sensor	5	5	5	5	5
RA Smoke Detector & CO ₂	10	10	10	10	10
SA Smoke Detector & CO ₂	10	10	10	10	10
RA & SA Smoke Detector & CO ₂	15	15	15	15	15
Medium Static Belt Drive	5	6	6	10	10
High Static Belt Drive	11	16	16	20	20
Cu/Cu Cond & Al/Cu Evap	28	34	34	34	34
Cu/Cu Cond & Cu/Cu Evap	53	64	64	64	64
Al/Cu Cond & Al/Cu Evap + Hail Guard	60	150	150	150	150
Pre-coat Al/Cu Cond & Al/Cu Evap + Hail Guard	60	150	150	150	150
E-coat Al/Cu Cond & Al/Cu Evap + Hail Guard	60	150	150	150	150
E-coat Al/Cu Cond & E-coat Al/Cu Evap + Hail Guard	60	150	150	150	150
Cu/Cu Cond & Al/Cu Evap + Hail Guard	88	184	184	184	184
Cu/Cu Cond & Cu/Cu Evap + Hail Guard	113	214	214	214	214
Temp Ultra Low Leak Econo w/Baro Relief	246	246	246	246	246
Temp Ultra Low Leak Econo w/ Power Exhaust	371	371	371	371	371
Enthalpy Ultra Low Leak Econo w/Baro Relief	246	246	246	246	246
Enthalpy Ultra Low Leak Econo w/ Power Exhaust	371	371	371	371	371
Unpowered Convenience Outlet	5	5	5	5	5
Powered Convenience outlet	35	35	35	35	35
Hinged Panels	5	5	5	5	5
Hinged Panels with Unpowered Convenience Outlet	10	10	10	10	10
Hinged Panels with Powered Convenience Outlet	40	40	40	40	40
HACR Breaker	10	10	10	10	10
Non-Fused Disconnect	15	15	15	15	15

APPLICATION DATA

Min operating ambient temp (cooling):

In mechanical cooling mode, your Carrier rooftop unit can safely operate down to an outdoor ambient temperature of 40°F (4°C). An economizer shall be the source of cooling in low ambient conditions. When the outside air temperature is below 40°F, to improve system reliability, reduce energy usage, and improve system efficiency: mechanical cooling shall not be utilized. Therefore, an economizer shall be used in these conditions to provide efficient low ambient cooling. Using an economizer for low ambient cooling merely requires fan energy to satisfy space requirements. The compressors shall not be required to run which will provide exceptional energy savings due to less power draw, improved system reliability due to fewer compressor run hours, improved reliability through fewer starts/stops, and lower life cycle costs due to reduced compressor maintenance.

Max operating ambient temp (cooling):

The maximum operating ambient temperature for cooling mode is 125°F (52°C). While cooling operation above 125°F (52°C) may be possible, it could cause either a reduction in performance, reliability, or a protective action by the unit's internal safety devices.

Min mixed air temp (heating):

Using the factory settings, the minimum temperatures for the mixed air (the combined temperature of the warm return air and the cold outdoor air) entering the dimpled, gas heat exchangers are:

<u>Aluminized</u>	<u>Stainless Steel</u>
50°F (10°C) continuous	40°F (4°C) continuous
45°F (7°C) intermittent	35°F (2°C) intermittent

Operating at lower mixed-air temperatures may be possible, if a field-supplied, outdoor air thermostat initiates both heat stages when the temperature is less than the minimum temperatures listed above. Please contact your local Carrier representative for assistance.

Min and max airflow (heating and cooling):

To maintain safe and reliable operation of your rooftop, operate within the heating airflow limits during heating mode and cooling airflow limits during cooling mode. Operating above the max may cause blow-off, undesired airflow noise, or airflow related problems with the rooftop unit. Operating below the min may cause problems with coil freeze-up and unsafe heating operation. For proper minimum and maximum CFM values see Tables 8 and 9.

Heating-to-cooling changeover:

Your unit will automatically change from heating to cooling mode when using a thermostat or sensor with an auto-change-over feature.

Airflow:

All units are draw-through in cooling mode and blow-through in heating mode.

Outdoor air application strategies:

Economizers reduce operating expenses and compressor run time by providing a free source of cooling and a means of ventilation to match application changing needs. In fact, they should be considered for most applications. Also, consider the various economizer control methods and their benefits, as well as sensors required to accomplish your application goals. Please contact your local Carrier representative for assistance.

Motor limits, break horsepower (BHP):

Due to internal design of Carrier units, the air path, and specially designed motors, the full horsepower (maximum continuous BHP) band, as listed in Table 10, can be used with the utmost confidence. There is no need for extra safety factors, as Carrier motors are designed and rigorously tested to use the entire, listed BHP range without either nuisance tripping or premature motor failure.

Propane heating:

Propane has different physical qualities than natural gas. As a result, Propane requires different fuel to air mixture. To optimize the fuel/air mixture for Propane, Carrier sells different burner orifices in an easy to install accessory kit. To select the correct burner orifices or determine the heat capacity for a Propane application, use either the selection software, or the unit's service manual.

High altitude heating:

High altitudes have less oxygen, which affects the fuel/air mixture in heat exchangers. In order to maintain a proper fuel/air mixture, heat exchangers operating in altitudes above 2000 ft (610 m) require different orifices. To select the correct burner orifices or determine the heat capacity for a high altitude application, use either the selection software, or the unit's service manual.

High altitudes have less oxygen, which means heat exchangers need less fuel. The new gas orifices in this field-installed kit make the necessary adjustment for high altitude applications. They restore the optimal fuel to air mixture and maintain healthy combustion on altitudes above 2000 ft (610 m).

NOTE: Typical natural gas heating value ranges from 975 to 1050 Btu/ft³ at sea level nationally. The heating value goes down approximately 1.7% per every thousand feet elevation. Standard factory orifices can typically be used up to 2000 ft (610 m) elevation without any operational issues.

APPLICATION DATA (cont.)

Sizing a rooftop

Bigger isn't necessarily better. While an air conditioner needs to have enough capacity to meet the design loads, it doesn't need excess capacity. In fact, excess capacity typically results in very poor part load performance and humidity control.

Using higher design temperatures than ASHRAE recommends for your location, adding "safety factors" to the calculated load, are all signs of oversizing air conditioners. Oversizing the air conditioner leads to poor humidity control, reduced efficiency, higher utility bills, larger indoor temperature swings, excessive noise, and increased wear and tear on the air conditioner.

Rather than oversizing an air conditioner, engineers should "right-size" or even slightly undersize air conditioners. Correctly sizing an air conditioner controls humidity better; promotes efficiency; reduces utility bills; extends equipment life, and maintains even, comfortable temperatures. Please contact your local Carrier representative for assistance.



Climaproyectos
.com

Table 12 – COOLING CAPACITIES - FIRST STAGE, PART LOAD

12.5 TONS

14 SIZE			AMBIENT TEMPERATURE																
			85°F			95°F			105°F			115°F			125°F				
			EAT (db)			EAT (db)			EAT (db)			EAT (db)			EAT (db)				
			75	80	85	75	80	85	75	80	85	75	80	85	75	80	85		
2000 Cfm	EAT (wb)	58	TC	58.0	58.0	66.0	54.1	54.1	61.9	50.2	50.2	57.6	46.0	46.0	53.1	41.7	41.7	48.6	
			SHC	49.9	58.0	66.0	46.3	54.1	61.9	42.7	50.2	57.6	38.9	46.0	53.1	35.0	41.7	48.6	
		62	TC	58.8	58.8	67.6	54.4	54.4	64.4	50.3	50.3	60.3	46.1	46.1	55.7	41.8	41.8	50.9	
			SHC	46.7	57.1	67.6	43.7	54.0	64.4	40.3	50.3	60.3	36.7	46.1	55.7	32.8	41.8	50.9	
		67	TC	65.8	65.8	65.8	60.9	60.9	60.9	56.1	56.1	56.1	50.9	50.9	50.9	45.6	45.6	46.8	
			SHC	37.5	48.1	58.7	34.7	45.2	55.8	31.8	42.3	52.8	28.8	39.3	49.8	25.7	36.3	46.8	
	72	TC	73.9	73.9	73.9	68.8	68.8	68.8	63.6	63.6	63.6	58.1	58.1	58.1	52.5	52.5	52.5		
		SHC	28.1	38.7	49.3	25.2	35.8	46.4	22.3	32.9	43.5	19.3	29.9	40.6	16.4	26.9	37.5		
	76	TC	-	80.9	80.9	-	75.5	75.5	-	69.9	69.9	-	64.2	64.2	-	58.2	58.2		
		SHC	-	31.0	41.7	-	28.1	38.8	-	25.3	35.9	-	22.2	33.0	-	19.3	29.9		
	2350 Cfm	EAT (wb)	58	TC	61.8	61.8	70.4	57.8	57.8	66.0	53.6	53.6	61.4	49.2	49.2	56.7	44.7	44.7	51.8
				SHC	53.3	61.8	70.4	49.6	57.8	66.0	45.7	53.6	61.4	41.7	49.2	56.7	37.6	44.7	51.8
62			TC	61.9	61.9	73.3	57.9	57.9	68.8	53.7	53.7	64.2	49.3	49.3	59.3	44.8	44.8	54.2	
			SHC	50.6	61.9	73.3	46.9	57.9	68.8	43.2	53.7	64.2	39.3	49.3	59.3	35.3	44.8	54.2	
67			TC	67.8	67.8	67.8	62.8	62.8	62.8	57.7	57.7	59.4	52.5	52.5	56.4	47.0	47.0	53.1	
			SHC	40.8	53.0	65.3	37.8	50.1	62.4	34.9	47.1	59.4	31.9	44.1	56.4	28.8	41.0	53.1	
72		TC	76.1	76.1	76.1	70.7	70.7	70.7	65.2	65.2	65.2	59.6	59.6	59.6	53.7	53.7	53.7		
		SHC	29.5	41.9	54.3	26.6	39.0	51.4	23.7	36.1	48.4	20.8	33.1	45.4	17.6	30.0	42.3		
76		TC	-	83.1	83.1	-	77.4	77.4	-	71.7	71.7	-	65.7	65.7	-	59.6	59.6		
		SHC	-	32.9	45.3	-	29.9	42.4	-	27.0	39.4	-	24.0	36.4	-	21.0	33.3		
2700 Cfm		EAT (wb)	58	TC	65.0	65.0	73.9	60.8	60.8	69.3	56.5	56.5	64.5	51.9	51.9	59.6	47.1	47.1	54.4
				SHC	56.2	65.0	73.9	52.3	60.8	69.3	48.3	56.5	64.5	44.1	51.9	59.6	39.8	47.1	54.4
	62		TC	65.1	65.1	77.0	60.8	60.8	72.2	56.5	56.5	67.4	51.9	51.9	62.3	47.2	47.2	56.9	
			SHC	53.3	65.1	77.0	49.5	60.8	72.2	45.6	56.5	67.4	41.5	51.9	62.3	37.3	47.2	56.9	
	67		TC	69.3	69.3	71.8	64.3	64.3	68.7	59.0	59.0	65.6	53.6	53.6	62.4	48.2	48.2	59.1	
			SHC	43.8	57.8	71.8	40.9	54.8	68.7	37.8	51.7	65.6	34.7	48.6	62.4	31.5	45.2	59.1	
	72	TC	77.6	77.6	77.6	72.1	72.1	72.1	66.5	66.5	66.5	60.7	60.7	60.7	54.7	54.7	54.7		
		SHC	30.9	45.0	59.1	28.0	42.0	56.1	25.0	39.0	53.0	21.9	36.0	50.0	18.9	32.9	46.9		
	76	TC	-	84.6	84.6	-	78.8	78.8	-	72.9	72.9	-	66.9	66.9	-	60.5	60.5		
		SHC	-	34.5	48.7	-	31.6	45.7	-	28.6	42.7	-	25.5	39.7	-	22.4	36.5		
	3050 Cfm	EAT (wb)	58	TC	67.8	67.8	76.9	63.3	63.3	72.2	58.8	58.8	67.2	54.0	54.0	62.0	49.0	49.0	56.6
				SHC	58.6	67.8	76.9	54.5	63.3	72.2	50.3	58.8	67.2	46.0	54.0	62.0	41.5	49.0	56.6
62			TC	67.9	67.9	80.0	63.4	63.4	75.2	58.8	58.8	70.1	54.1	54.1	64.7	49.1	49.1	59.3	
			SHC	55.6	67.9	80.0	51.7	63.4	75.2	47.6	58.8	70.1	43.4	54.1	64.7	39.0	49.1	59.3	
67			TC	70.6	70.6	77.8	65.4	65.4	74.7	60.2	60.2	71.4	54.8	54.8	68.0	49.4	49.4	63.7	
			SHC	46.7	62.2	77.8	43.7	59.2	74.7	40.6	56.0	71.4	37.3	52.7	68.0	33.8	48.8	63.7	
72		TC	78.8	78.8	78.8	73.2	73.2	73.2	67.5	67.5	67.5	61.5	61.5	61.5	55.5	55.5	55.5		
		SHC	32.2	47.9	63.7	29.3	44.9	60.6	26.2	41.8	57.5	23.1	38.8	54.5	20.0	35.7	51.3		
76		TC	-	85.9	85.9	-	80.0	80.0	-	73.9	73.9	-	67.7	67.7	-	61.3	61.3		
		SHC	-	36.1	51.9	-	33.2	48.8	-	30.1	45.8	-	27.0	42.7	-	23.9	39.6		
3350 Cfm		EAT (wb)	58	TC	69.7	69.7	79.1	65.1	65.1	74.2	60.5	60.5	69.0	55.6	55.6	63.8	50.5	50.5	58.3
				SHC	60.4	69.7	79.1	56.2	65.1	74.2	51.9	60.5	69.0	47.4	55.6	63.8	42.8	50.5	58.3
	62		TC	69.8	69.8	82.4	65.2	65.2	77.3	60.5	60.5	72.1	55.7	55.7	66.6	50.6	50.6	60.9	
			SHC	57.2	69.8	82.4	53.2	65.2	77.3	49.0	60.5	72.1	44.8	55.7	66.6	40.3	50.6	60.9	
	67		TC	71.6	71.6	82.7	66.4	66.4	79.5	61.1	61.1	75.9	55.9	55.9	71.8	50.7	50.7	66.2	
			SHC	48.9	65.8	82.7	45.9	62.7	79.5	42.7	59.3	75.9	39.3	55.6	71.8	35.2	50.7	66.2	
	72	TC	79.6	79.6	79.6	73.9	73.9	73.9	68.2	68.2	68.2	62.1	62.1	62.1	56.0	56.0	56.0		
		SHC	33.2	50.3	67.4	30.2	47.3	64.4	27.1	44.2	61.2	24.1	41.1	58.1	21.0	37.9	54.9		
	76	TC	-	86.8	86.8	-	80.7	80.7	-	74.6	74.6	-	68.3	68.3	-	61.8	61.8		
		SHC	-	37.3	54.5	-	34.3	51.5	-	31.3	48.4	-	28.2	45.2	-	25.1	42.0		

LEGEND:

- - Do not operate
- Cfm - Cubic feet per minute (supply air)
- EAT (db) - Entering Air Temperature (dry bulb)
- EAT (wb) - Entering Air Temperature (wet bulb)
- SHC - Sensible Heat Capacity (1000 Btuh) Gross
- TC - Total Capacity (1000 Btuh) Gross

Table 13 – COOLING CAPACITIES - SECOND STAGE, PART LOAD

12.5 TONS

14 SIZE			AMBIENT TEMPERATURE																
			85°F			95°F			105°F			115°F			125°F				
			EAT (db)			EAT (db)			EAT (db)			EAT (db)			EAT (db)				
			75	80	85	75	80	85	75	80	85	75	80	85	75	80	85		
3000 Cfm	EAT (wb)	58	TC	76.5	76.5	88.1	69.1	69.1	80.2	61.5	61.5	72.2	53.7	53.7	63.9	45.6	45.6	55.3	
			SHC	64.9	76.5	88.1	57.9	69.1	80.2	50.8	61.5	72.2	43.5	53.7	63.9	36.0	45.6	55.3	
		62	TC	76.6	76.6	92.1	69.2	69.2	84.1	61.6	61.6	75.9	53.8	53.8	67.5	45.7	45.7	58.7	
			SHC	61.2	76.6	92.1	54.3	69.2	84.1	47.3	61.6	75.9	40.2	53.8	67.5	32.9	45.7	58.7	
		67	TC	86.9	86.9	86.9	78.0	78.0	78.0	68.9	68.9	68.9	59.7	59.7	61.6	50.2	50.2	55.3	
			SHC	48.4	64.3	80.0	42.2	58.1	74.0	36.1	52.0	67.9	29.9	45.7	61.6	23.6	39.5	55.3	
	72	TC	99.1	99.1	99.1	89.8	89.8	89.8	80.2	80.2	80.2	70.5	70.5	70.5	60.5	60.5	60.5		
		SHC	35.0	51.0	67.0	29.0	44.9	60.8	22.8	38.8	54.7	16.7	32.6	48.5	10.4	26.3	42.2		
	76	TC	-	109.5	109.5	-	99.8	99.8	-	90.0	90.0	-	79.8	79.8	-	69.2	69.2		
		SHC	-	40.2	56.3	-	34.1	50.2	-	28.0	44.1	-	21.8	37.8	-	15.5	31.6		
	3500 Cfm	EAT (wb)	58	TC	82.1	82.1	94.3	74.3	74.3	86.0	66.3	66.3	77.5	58.1	58.1	68.7	49.7	49.7	59.8
				SHC	69.9	82.1	94.3	62.6	74.3	86.0	55.1	66.3	77.5	47.5	58.1	68.7	39.6	49.7	59.8
62			TC	82.2	82.2	98.5	74.4	74.4	90.0	66.4	66.4	81.3	58.2	58.2	72.4	49.8	49.8	63.3	
			SHC	66.0	82.2	98.5	58.8	74.4	90.0	51.5	66.4	81.3	44.0	58.2	72.4	36.3	49.8	63.3	
67			TC	89.6	89.6	89.8	80.4	80.4	83.6	71.2	71.2	77.3	61.7	61.7	70.9	52.0	52.0	64.4	
			SHC	53.1	71.5	89.8	46.9	65.2	83.6	40.7	59.0	77.3	34.3	52.7	70.9	27.9	46.1	64.4	
72		TC	101.8	101.8	101.8	92.2	92.2	92.2	82.5	82.5	82.5	72.3	72.3	72.3	62.0	62.0	62.0		
		SHC	37.3	55.8	74.2	31.1	49.6	68.1	24.9	43.4	61.8	18.6	37.1	55.5	12.3	30.6	49.0		
76		TC	-	112.4	112.4	-	102.4	102.4	-	92.2	92.2	-	81.7	81.7	-	70.9	70.9		
		SHC	-	43.0	61.6	-	36.8	55.4	-	30.6	49.1	-	24.3	42.8	-	17.9	36.4		
4000 Cfm		EAT (wb)	58	TC	86.7	86.7	99.3	78.6	78.6	90.7	70.3	70.3	81.9	61.8	61.8	72.7	53.0	53.0	63.4
				SHC	74.1	86.7	99.3	66.5	78.6	90.7	58.7	70.3	81.9	50.8	61.8	72.7	42.6	53.0	63.4
	62		TC	86.8	86.8	103.6	78.7	78.7	94.9	70.4	70.4	85.9	61.9	61.9	76.6	53.1	53.1	67.0	
			SHC	69.9	86.8	103.6	62.5	78.7	94.9	54.9	70.4	85.9	47.2	61.9	76.6	39.2	53.1	67.0	
	67		TC	91.7	91.7	99.2	82.5	82.5	92.7	73.0	73.0	86.3	63.4	63.4	79.6	53.6	53.6	72.5	
			SHC	57.6	78.4	99.2	51.3	72.1	92.7	44.9	65.6	86.3	38.5	59.0	79.6	31.9	52.2	72.5	
	72	TC	103.9	103.9	103.9	94.1	94.1	94.1	84.1	84.1	84.1	73.8	73.8	73.8	63.3	63.3	63.3		
		SHC	39.4	60.3	81.2	33.2	54.0	75.0	26.8	47.7	68.6	20.5	41.3	62.2	13.9	34.8	55.7		
	76	TC	-	114.6	114.6	-	104.3	104.3	-	93.9	93.9	-	83.2	83.2	-	72.2	72.2		
		SHC	-	45.5	66.6	-	39.3	60.4	-	33.0	53.9	-	26.5	47.5	-	20.1	41.0		
	4500 Cfm	EAT (wb)	58	TC	90.6	90.6	103.5	82.2	82.2	94.7	73.6	73.6	85.5	64.8	64.8	76.1	55.8	55.8	66.5
				SHC	77.5	90.6	103.5	69.7	82.2	94.7	61.7	73.6	85.5	53.5	64.8	76.1	45.0	55.8	66.5
62			TC	90.7	90.7	108.0	82.3	82.3	99.0	73.7	73.7	89.6	64.9	64.9	80.0	55.9	55.9	70.1	
			SHC	73.3	90.7	108.0	65.6	82.3	99.0	57.8	73.7	89.6	49.8	64.9	80.0	41.5	55.9	70.1	
67			TC	93.6	93.6	107.9	84.2	84.2	101.3	74.8	74.8	94.5	65.3	65.3	87.0	56.2	56.2	76.8	
			SHC	61.8	84.9	107.9	55.4	78.4	101.3	48.9	71.8	94.5	42.1	64.5	87.0	34.4	55.6	76.8	
72		TC	105.5	105.5	105.5	95.6	95.6	95.6	85.4	85.4	85.4	74.9	74.9	74.9	64.3	64.3	64.3		
		SHC	41.2	64.5	87.9	34.9	58.2	81.5	28.6	51.9	75.2	22.1	45.3	68.6	15.6	38.8	62.0		
76		TC	-	116.2	116.2	-	105.9	105.9	-	95.2	95.2	-	84.2	84.2	-	73.0	73.0		
		SHC	-	47.9	71.3	-	41.5	64.9	-	35.2	58.5	-	28.8	52.0	-	22.1	45.3		
4950 Cfm		EAT (wb)	58	TC	93.5	93.5	106.9	84.9	84.9	97.7	76.2	76.2	88.3	67.2	67.2	78.8	57.9	57.9	68.8
				SHC	80.2	93.5	106.9	72.2	84.9	97.7	64.1	76.2	88.3	55.7	67.2	78.8	47.0	57.9	68.8
	62		TC	93.6	93.6	111.4	85.1	85.1	102.1	76.3	76.3	92.5	67.3	67.3	82.7	58.0	58.0	72.5	
			SHC	75.9	93.6	111.4	68.1	85.1	102.1	60.1	76.3	92.5	51.9	67.3	82.7	43.4	58.0	72.5	
	67		TC	95.2	95.2	115.3	85.8	85.8	108.4	76.4	76.4	100.8	67.6	67.6	89.9	58.1	58.1	80.0	
			SHC	65.4	90.4	115.3	58.9	83.7	108.4	52.1	76.4	100.8	44.1	67.0	89.9	36.3	58.1	80.0	
	72	TC	106.7	106.7	106.7	96.6	96.6	96.6	86.3	86.3	86.3	75.8	75.8	75.8	64.9	64.9	67.6		
		SHC	42.9	68.3	93.7	36.5	61.9	87.3	30.1	55.5	80.8	23.6	48.9	74.3	17.1	42.3	67.6		
	76	TC	-	117.4	117.4	-	107.0	107.0	-	96.1	96.1	-	85.1	85.1	-	73.7	73.7		
		SHC	-	49.9	75.4	-	43.5	69.0	-	37.1	62.5	-	30.5	55.9	-	24.0	49.1		

LEGEND:

- - Do not operate
- Cfm - Cubic feet per minute (supply air)
- EAT (db) - Entering Air Temperature (dry bulb)
- EAT (wb) - Entering Air Temperature (wet bulb)
- SHC - Sensible Heat Capacity (1000 Btuh) Gross
- TC - Total Capacity (1000 Btuh) Gross

Table 14 – COOLING CAPACITIES - THIRD STAGE, FULL LOAD

12.5 TONS

14 SIZE			AMBIENT TEMPERATURE																
			85°F			95°F			105°F			115°F			125°F				
			EAT (db)			EAT (db)			EAT (db)			EAT (db)			EAT (db)				
			75	80	85	75	80	85	75	80	85	75	80	85	75	80	85		
3750 Cfm	EAT (wb)	58	TC	127.7	127.7	145.1	120.8	120.8	137.6	113.6	113.6	129.6	106.0	106.0	121.3	98.0	98.0	112.6	
			SHC	110.4	127.7	145.1	104.0	120.8	137.6	97.5	113.6	129.6	90.6	106.0	121.3	83.5	98.0	112.6	
		62	TC	133.7	133.7	138.8	125.3	125.3	133.7	116.6	116.6	128.3	107.6	107.6	122.8	98.9	98.9	116.2	
			SHC	99.6	119.2	138.8	94.6	114.1	133.7	89.3	108.8	128.3	83.9	103.4	122.8	78.1	97.1	116.2	
		67	TC	148.2	148.2	148.2	139.2	139.2	139.2	129.8	129.8	129.8	120.1	120.1	120.1	110.0	110.0	110.0	
			SHC	81.6	101.3	121.0	76.5	96.2	115.9	71.4	91.1	110.8	66.1	85.8	105.4	60.6	80.3	99.9	
	72	TC	164.3	164.3	164.3	154.8	154.8	154.8	144.9	144.9	144.9	134.6	134.6	134.6	123.6	123.6	123.6		
		SHC	63.2	83.0	102.9	58.2	78.0	97.8	53.1	72.9	92.6	47.9	67.7	87.5	42.5	62.3	82.0		
	76	TC	-	177.9	177.9	-	168.0	168.0	-	157.7	157.7	-	146.6	146.6	-	-	-		
		SHC	-	68.0	88.0	-	63.1	83.2	-	58.0	78.1	-	52.8	72.9	-	-	-		
	4400 Cfm	EAT (wb)	58	TC	136.2	136.2	154.5	128.8	128.8	146.4	121.1	121.1	138.0	113.0	113.0	129.1	104.5	104.5	119.8
				SHC	117.9	136.2	154.5	111.2	128.8	146.4	104.1	121.1	138.0	96.8	113.0	129.1	89.1	104.5	119.8
62			TC	138.8	138.8	154.1	130.3	130.3	148.6	121.9	121.9	142.2	113.1	113.1	134.7	104.6	104.6	125.2	
			SHC	108.9	131.5	154.1	103.5	126.1	148.6	97.9	120.0	142.2	91.6	113.1	134.7	84.1	104.6	125.2	
67			TC	152.9	152.9	152.9	143.5	143.5	143.5	133.8	133.8	133.8	123.6	123.6	123.6	113.1	113.1	113.1	
			SHC	87.7	110.5	133.4	82.5	105.4	128.2	77.2	100.0	122.9	71.9	94.7	117.5	66.4	89.1	111.9	
72		TC	169.1	169.1	169.1	159.2	159.2	159.2	148.9	148.9	148.9	138.2	138.2	138.2	126.8	126.8	126.8		
		SHC	66.0	89.0	111.9	60.9	83.9	106.9	55.8	78.7	101.7	50.5	73.4	96.3	45.0	68.0	90.9		
76		TC	-	182.8	182.8	-	172.5	172.5	-	161.8	161.8	-	150.5	150.5	-	-	-		
		SHC	-	71.5	94.9	-	66.4	89.8	-	61.3	84.6	-	56.1	79.4	-	-	-		
5000 Cfm		EAT (wb)	58	TC	142.6	142.6	161.8	134.8	134.8	153.2	126.8	126.8	144.3	118.3	118.3	135.0	109.4	109.4	125.3
				SHC	123.6	142.6	161.8	116.5	134.8	153.2	109.2	126.8	144.3	101.5	118.3	135.0	93.5	109.4	125.3
	62		TC	143.2	143.2	166.7	135.0	135.0	159.5	126.9	126.9	150.4	118.5	118.5	140.8	109.6	109.6	130.8	
			SHC	116.6	141.7	166.7	110.5	135.0	159.5	103.4	126.9	150.4	96.0	118.5	140.8	88.3	109.6	130.8	
	67		TC	156.1	156.1	156.1	146.5	146.5	146.5	136.5	136.5	136.5	126.3	126.3	128.1	115.4	115.4	122.4	
			SHC	92.8	118.6	144.3	87.7	113.4	139.0	82.3	107.9	133.7	76.8	102.5	128.1	71.3	96.8	122.4	
	72	TC	172.4	172.4	172.4	162.2	162.2	162.2	151.6	151.6	151.6	140.6	140.6	140.6	129.1	129.1	129.1		
		SHC	68.3	94.2	120.0	63.2	89.0	114.9	58.0	83.8	109.6	52.7	78.4	104.1	47.1	72.8	98.6		
	76	TC	-	186.2	186.2	-	175.7	175.7	-	164.7	164.7	-	153.2	153.2	-	-	-		
		SHC	-	74.3	100.5	-	69.3	95.5	-	64.2	90.2	-	58.8	84.9	-	-	-		
	5650 Cfm	EAT (wb)	58	TC	148.5	148.5	168.3	140.3	140.3	159.3	131.9	131.9	150.1	123.0	123.0	140.4	113.9	113.9	130.3
				SHC	128.8	148.5	168.3	121.4	140.3	159.3	113.7	131.9	150.1	105.8	123.0	140.4	97.4	113.9	130.3
62			TC	148.7	148.7	175.1	140.5	140.5	165.8	132.0	132.0	156.3	123.2	123.2	146.3	114.0	114.0	135.9	
			SHC	122.3	148.7	175.1	115.1	140.5	165.8	107.7	132.0	156.3	100.0	123.2	146.3	92.0	114.0	135.9	
67			TC	159.0	159.0	159.0	149.3	149.3	150.2	139.0	139.0	144.8	128.5	128.5	139.1	117.6	117.6	133.2	
			SHC	98.2	126.9	155.6	92.9	121.6	150.2	87.6	116.1	144.8	82.0	110.6	139.1	76.3	104.8	133.2	
72		TC	175.2	175.2	175.2	164.8	164.8	164.8	154.1	154.1	154.1	142.7	142.7	142.7	130.9	130.9	130.9		
		SHC	70.6	99.5	128.3	65.5	94.3	123.1	60.3	89.0	117.8	54.8	83.6	112.3	49.2	78.0	106.7		
76		TC	-	189.2	189.2	-	178.3	178.3	-	167.1	167.1	-	155.4	155.4	-	-	-		
		SHC	-	77.2	106.5	-	72.2	101.3	-	67.0	96.0	-	61.6	90.7	-	-	-		
6250 Cfm		EAT (wb)	58	TC	153.1	153.1	173.4	144.7	144.7	164.2	135.9	135.9	154.5	126.8	126.8	144.6	117.3	117.3	134.1
				SHC	132.8	153.1	173.4	125.2	144.7	164.2	117.3	135.9	154.5	109.0	126.8	144.6	100.4	117.3	134.1
	62		TC	153.2	153.2	180.3	144.9	144.9	170.9	136.0	136.0	161.0	126.9	126.9	150.6	117.4	117.4	139.8	
			SHC	126.2	153.2	180.3	118.9	144.9	170.9	111.2	136.0	161.0	103.3	126.9	150.6	95.0	117.4	139.8	
	67		TC	161.3	161.3	165.8	151.3	151.3	160.3	141.0	141.0	154.6	130.4	130.4	148.8	119.4	119.4	142.5	
			SHC	103.0	134.4	165.8	97.6	129.0	160.3	92.1	123.4	154.6	86.6	117.7	148.8	80.7	111.6	142.5	
	72	TC	177.4	177.4	177.4	166.8	166.8	166.8	155.8	155.8	155.8	144.3	144.3	144.3	132.3	132.3	132.3		
		SHC	72.6	104.2	135.8	67.5	99.0	130.6	62.2	93.7	125.2	56.7	88.1	119.6	51.1	82.6	114.0		
	76	TC	-	191.4	191.4	-	180.4	180.4	-	169.0	169.0	-	157.1	157.1	-	-	-		
		SHC	-	79.9	111.7	-	74.7	106.6	-	69.4	101.3	-	64.1	95.8	-	-	-		

LEGEND:

- - Do not operate
- Cfm - Cubic feet per minute (supply air)
- EAT (db) - Entering Air Temperature (dry bulb)
- EAT (wb) - Entering Air Temperature (wet bulb)
- SHC - Sensible Heat Capacity (1000 Btuh) Gross
- TC - Total Capacity (1000 Btuh) Gross

48LC*A14 REHEAT MODE #1 CAPACITIES (MBTUH), STANDARD UNITS

Reheat-1 (Subcooler Mode)		AIR ENTERING EVAPORATOR - SCFM/BF (80db)								
		3750			5000			6250		
Outdoor Air Temp ° F		Air Entering Evaporator -- Ewb (F)								
		72	67	62	72	67	62	72	67	62
75	TC	165	148	135	173	158	146	179	164	153
	SHC	72	90	111	83	109	135	93	125	153
	kW	8.2	7.9	7.7	8.3	8.1	7.9	8.4	8.2	8.0
85	TC	156	142	130	163	149	138	168	155	144
	SHC	64	85	106	73	100	128	83	117	141
	kW	9.1	8.9	8.6	9.2	9.0	8.8	9.3	9.1	8.9
95	TC	147	132	123	154	140	129	158	144	135
	SHC	56	75	100	65	92	120	74	107	135
	kW	10.1	9.8	9.7	10.3	10.0	9.8	10.3	10.1	9.9
105	TC	138	123	114	145	131	121	148	134	126
	SHC	47	67	92	57	84	112	65	98	126
	kW	11.3	11.0	10.8	11.4	11.1	10.9	11.5	11.2	11.0
115	TC	129	116	107	133	122	112	137	125	117
	SHC	39	61	85	46	76	104	55	89	113
	kW	12.6	12.3	12.1	12.6	12.4	12.2	12.7	12.5	12.3
125	TC	119	108	99	124	112	104	127	115	108
	SHC	31	54	78	39	67	97	46	80	108
	kW	14.0	13.7	13.5	14.1	13.8	13.6	14.1	13.8	13.7

LEGEND AND NOTES

- kW --- Compressor Power Input
- SHC --- Sensible Heat Capacity (1000 Btuh) Gross
- TC --- Total Capacity(1000 Btuh) Gross

48LC*A14 REHEAT MODE #2 CAPACITIES (MBTUH), STANDARD UNITS

Reheat-2 (Hot Gas Reheat Mode)		AIR ENTERING EVAPORATOR - SCFM/BF (80db)								
		3750			5000			6250		
Outdoor Air Temp ° F		Air Entering Evaporator -- Ewb (F)								
		62.5	64	65.3	62.5	64	65.3	62.5	64	65.3
80	TC	52	53	54	54	55	56	55	56	58
	SHC	10	1	-6	20	9	1	31	19	8
	kW	11.2	11.4	11.5	11.3	11.4	11.6	11.3	11.5	11.6
75	TC	54	56	57	57	58	59	58	59	61
	SHC	12	4	-4	22	12	3	33	21	11
	kW	10.7	10.9	11.0	10.8	10.9	11.1	10.8	11.0	11.1
70	TC	57	58	60	59	61	62	61	62	63
	SHC	14	6	-1	25	14	6	36	24	14
	kW	10.2	10.4	10.5	10.3	10.5	10.6	10.4	10.5	10.6
60	TC	62	63	65	64	66	68	66	68	69
	SHC	19	11	4	29	19	11	40	29	19
	kW	9.4	9.5	9.6	9.4	9.6	9.7	9.5	9.6	9.8
50	TC	67	68	70	70	71	73	71	73	75
	SHC	23	15	8	34	24	16	45	34	24
	kW	8.6	8.7	8.8	8.7	8.8	8.9	8.7	8.9	9.0
40	TC	72	74	76	75	77	79	77	79	81
	SHC	28	20	14	39	30	21	51	40	30
	kW	7.9	8.0	8.1	8.0	8.1	8.2	8.1	8.2	8.3

LEGEND AND NOTES

- kW --- Compressor Power Input
- SHC --- Sensible Heat Capacity (1000 Btuh) Gross
- TC --- Total Capacity (1000 Btuh) Gross

Table 16 – COOLING CAPACITIES - FIRST STAGE, PART LOAD

15 TONS

17 SIZE			AMBIENT TEMPERATURE																
			85°F			95°F			105°F			115°F			125°F				
			EAT (db)			EAT (db)			EAT (db)			EAT (db)			EAT (db)				
			75	80	85	75	80	85	75	80	85	75	80	85	75	80	85		
2550 Cfm	EAT (wb)	58	TC	119.0	119.0	132.0	71.3	71.3	80.9	67.2	67.2	76.3	62.7	62.7	71.5	57.8	57.8	66.1	
			SHC	105.9	119.0	132.0	61.6	71.3	80.9	57.9	67.2	76.3	53.8	62.7	71.5	49.4	57.8	66.1	
		62	TC	75.3	75.3	88.4	71.4	71.4	84.2	67.3	67.3	79.6	62.8	62.8	74.5	57.9	57.9	69.0	
			SHC	61.7	75.1	88.4	58.5	71.4	84.2	54.9	67.3	79.6	51.0	62.8	74.5	46.8	57.9	69.0	
		67	TC	83.4	83.4	83.4	78.5	78.5	78.5	107.8	107.8	119.8	67.7	67.7	68.4	61.5	61.5	65.3	
			SHC	49.5	63.2	76.7	47.0	60.5	74.1	95.8	107.8	119.8	41.3	54.9	68.4	38.2	51.8	65.3	
	72	TC	93.0	93.0	93.0	87.8	87.8	87.8	82.3	82.3	82.3	76.2	76.2	76.2	69.7	69.7	69.7		
		SHC	37.0	50.6	64.3	34.3	48.0	61.7	31.7	45.3	59.0	28.8	42.4	56.1	25.7	39.4	53.0		
	76	TC	-	101.4	101.4	-	96.0	96.0	-	90.2	90.2	-	83.9	83.9	-	76.9	76.9		
		SHC	-	40.3	54.0	-	37.7	51.5	-	35.1	48.8	-	32.3	45.9	-	29.3	42.9		
	2950 Cfm	EAT (wb)	58	TC	79.2	79.2	89.7	75.2	75.2	85.3	208.3	208.3	208.3	66.1	66.1	75.3	121.4	121.4	121.4
				SHC	68.7	79.2	89.7	65.0	75.2	85.3	65.0	80.8	96.6	56.8	66.1	75.3	34.7	50.4	66.1
62			TC	79.3	79.3	93.3	75.3	75.3	88.8	70.9	70.9	83.9	66.2	66.2	78.5	61.0	61.0	72.6	
			SHC	65.3	79.3	93.3	61.8	75.3	88.8	58.0	70.9	83.9	53.8	66.2	78.5	49.4	61.0	72.6	
67			TC	85.4	85.4	85.4	80.4	80.4	81.8	75.1	75.1	79.1	69.2	69.2	76.1	63.0	63.0	72.8	
			SHC	53.2	68.9	84.5	50.6	66.2	81.8	47.9	63.5	79.1	44.9	60.5	76.1	41.7	57.3	72.8	
72		TC	95.2	95.2	95.2	89.9	89.9	89.9	84.0	84.0	84.0	77.9	77.9	77.9	71.1	71.1	71.1		
		SHC	38.6	54.3	70.1	36.0	51.7	67.5	33.2	48.9	64.6	30.3	46.0	61.8	27.3	43.0	58.7		
76		TC	-	103.7	103.7	-	98.2	98.2	-	92.0	92.0	-	85.5	85.5	-	78.4	78.4		
		SHC	-	42.4	58.2	-	39.9	55.7	-	37.1	52.9	-	34.3	50.1	-	31.3	47.1		
3400 Cfm		EAT (wb)	58	TC	83.1	83.1	94.0	78.9	78.9	89.4	74.3	74.3	84.3	69.3	69.3	78.9	63.9	63.9	72.9
				SHC	72.2	83.1	94.0	68.3	78.9	89.4	64.2	74.3	84.3	59.7	69.3	78.9	54.9	63.9	72.9
	62		TC	83.2	83.2	97.8	79.0	79.0	93.0	74.4	74.4	87.8	69.3	69.3	82.2	64.0	64.0	76.1	
			SHC	68.5	83.2	97.8	64.8	79.0	93.0	60.8	74.4	87.8	56.6	69.3	82.2	51.9	64.0	76.1	
	67		TC	87.3	87.3	92.9	82.2	82.2	90.2	76.7	76.7	87.3	70.8	70.8	84.1	64.5	64.5	80.6	
			SHC	57.2	75.1	92.9	54.5	72.3	90.2	51.7	69.5	87.3	48.7	66.4	84.1	45.4	63.0	80.6	
	72	TC	97.0	97.0	97.0	91.6	91.6	91.6	85.6	85.6	85.6	79.3	79.3	79.3	72.3	72.3	72.3		
		SHC	40.4	58.3	76.3	37.7	55.7	73.7	34.9	52.9	70.9	32.0	50.0	68.0	28.9	46.9	64.8		
	76	TC	-	105.6	105.6	-	99.9	99.9	-	93.7	93.7	-	87.0	87.0	-	79.7	79.7		
		SHC	-	44.7	62.9	-	42.0	60.3	-	39.3	57.4	-	36.4	54.5	-	33.3	51.5		
	3800 Cfm	EAT (wb)	58	TC	86.0	86.0	97.2	81.6	81.6	92.4	76.8	76.8	87.3	71.7	71.7	81.5	66.1	66.1	75.4
				SHC	74.7	86.0	97.2	70.7	81.6	92.4	66.4	76.8	87.3	61.8	71.7	81.5	56.7	66.1	75.4
62			TC	86.1	86.1	101.1	81.7	81.7	96.2	76.9	76.9	90.8	71.8	71.8	84.9	66.2	66.2	78.6	
			SHC	71.0	86.1	101.1	67.2	81.7	96.2	63.0	76.9	90.8	58.6	71.8	84.9	53.7	66.2	78.6	
67			TC	88.6	88.6	100.1	83.5	83.5	97.3	78.0	78.0	94.2	72.2	72.2	90.7	66.3	66.3	84.6	
			SHC	60.5	80.3	100.1	57.8	77.6	97.3	54.9	74.6	94.2	51.8	71.2	90.7	47.6	66.1	84.6	
72		TC	98.3	98.3	98.3	92.7	92.7	92.7	86.7	86.7	86.7	80.1	80.1	80.1	73.1	73.1	73.1		
		SHC	41.7	61.8	81.8	39.1	59.1	79.2	36.3	56.4	76.3	33.3	53.3	73.3	30.2	50.2	70.2		
76		TC	-	107.0	107.0	-	101.2	101.2	-	94.9	94.9	-	87.9	87.9	-	80.5	80.5		
		SHC	-	46.5	66.7	-	43.9	64.1	-	41.1	61.3	-	38.2	58.3	-	35.1	55.3		
4250 Cfm		EAT (wb)	58	TC	88.7	88.7	100.3	84.2	84.2	95.4	79.3	79.3	90.0	73.9	73.9	84.0	68.2	68.2	77.7
				SHC	77.1	88.7	100.3	73.0	84.2	95.4	68.6	79.3	90.0	63.9	73.9	84.0	58.6	68.2	77.7
	62		TC	88.8	88.8	104.3	84.3	84.3	99.3	79.4	79.4	93.6	74.0	74.0	87.6	68.3	68.3	81.0	
			SHC	73.3	88.8	104.3	69.4	84.3	99.3	65.1	79.4	93.6	60.5	74.0	87.6	55.5	68.3	81.0	
	67		TC	90.1	90.1	107.7	84.9	84.9	104.6	79.6	79.6	100.7	74.1	74.1	94.4	68.3	68.3	87.5	
			SHC	64.2	86.0	107.7	61.3	83.0	104.6	58.1	79.5	100.7	53.8	74.1	94.4	49.2	68.3	87.5	
	72	TC	99.4	99.4	99.4	93.7	93.7	93.7	87.7	87.7	87.7	81.0	81.0	81.0	73.9	73.9	76.1		
		SHC	43.3	65.5	87.8	40.7	62.9	85.1	37.8	60.1	82.3	34.8	57.0	79.3	31.7	53.8	76.1		
	76	TC	-	108.1	108.1	-	102.3	102.3	-	95.8	95.8	-	88.8	88.8	-	81.3	81.3		
		SHC	-	48.6	70.9	-	45.9	68.3	-	43.1	65.5	-	40.2	62.5	-	37.1	59.4		

LEGEND:

- - Do not operate
- Cfm - Cubic feet per minute (supply air)
- EAT (db) - Entering Air Temperature (dry bulb)
- EAT (wb) - Entering Air Temperature (wet bulb)
- SHC - Sensible Heat Capacity (1000 Btuh) Gross
- TC - Total Capacity (1000 Btuh) Gross

Table 17 – COOLING CAPACITIES - SECOND STAGE, PART LOAD

15 TONS

17 SIZE			AMBIENT TEMPERATURE																
			85°F			95°F			105°F			115°F			125°F				
			EAT (db)			EAT (db)			EAT (db)			EAT (db)			EAT (db)				
			75	80	85	75	80	85	75	80	85	75	80	85	75	80	85		
3700 Cfm	EAT (wb)	58	TC	110.2	110.2	124.5	104.9	104.9	118.7	99.6	99.6	112.8	94.2	94.2	106.7	88.3	88.3	100.2	
			SHC	95.8	110.2	124.5	91.2	104.9	118.7	86.5	99.6	112.8	81.6	94.2	106.7	76.4	88.3	100.2	
		62	TC	110.4	110.4	129.5	105.1	105.1	123.4	99.7	99.7	117.4	94.3	94.3	111.1	88.4	88.4	104.3	
			SHC	91.3	110.4	129.5	86.7	105.1	123.4	82.2	99.7	117.4	77.5	94.3	111.1	72.5	88.4	104.3	
		67	TC	120.7	120.7	120.7	113.8	113.8	113.8	107.0	107.0	107.0	100.0	100.0	102.4	92.6	92.6	99.0	
			SHC	73.0	92.6	112.1	69.8	89.3	108.9	66.6	86.2	105.7	63.4	82.9	102.4	60.1	79.6	99.0	
	72	TC	133.5	133.5	133.5	125.9	125.9	125.9	118.5	118.5	118.5	110.9	110.9	110.9	102.9	102.9	102.9		
		SHC	54.2	73.9	93.6	51.0	70.7	90.3	47.8	67.5	87.1	44.7	64.3	83.9	41.3	60.9	80.6		
	76	TC	-	144.5	144.5	-	136.4	136.4	-	128.3	128.3	-	120.2	120.2	-	111.8	111.8		
		SHC	-	58.6	78.5	-	55.4	75.3	-	52.3	72.1	-	49.0	68.8	-	45.8	65.5		
	4300 Cfm	EAT (wb)	58	TC	115.8	115.8	130.8	110.2	110.2	124.5	104.4	104.4	118.2	98.6	98.6	111.7	92.4	92.4	104.8
				SHC	100.8	115.8	130.8	95.7	110.2	124.5	90.8	104.4	118.2	85.5	98.6	111.7	80.0	92.4	104.8
62			TC	115.9	115.9	136.0	110.3	110.3	129.5	104.6	104.6	122.9	98.8	98.8	116.2	92.5	92.5	109.1	
			SHC	95.9	115.9	136.0	91.1	110.3	129.5	86.2	104.6	122.9	81.2	98.8	116.2	76.0	92.5	109.1	
67			TC	123.5	123.5	123.5	116.3	116.3	120.0	109.3	109.3	116.7	102.1	102.1	113.3	94.6	94.6	109.7	
			SHC	78.3	100.8	123.3	75.0	97.5	120.0	71.7	94.2	116.7	68.4	90.9	113.3	64.9	87.4	109.7	
72		TC	136.3	136.3	136.3	128.4	128.4	128.4	120.6	120.6	120.6	112.8	112.8	112.8	104.6	104.6	104.6		
		SHC	56.5	79.2	101.9	53.1	75.9	98.5	49.9	72.6	95.3	46.7	69.3	92.0	43.4	66.0	88.6		
76		TC	-	147.4	147.4	-	139.0	139.0	-	130.7	130.7	-	122.4	122.4	-	113.7	113.7		
		SHC	-	61.5	84.4	-	58.2	81.0	-	55.0	77.8	-	51.8	74.6	-	48.5	71.2		
4900 Cfm		EAT (wb)	58	TC	120.4	120.4	136.0	114.5	114.5	129.4	108.4	108.4	122.7	102.3	102.3	115.8	95.7	95.7	108.5
				SHC	104.9	120.4	136.0	99.5	114.5	129.4	94.2	108.4	122.7	88.7	102.3	115.8	83.0	95.7	108.5
	62		TC	120.6	120.6	141.4	114.6	114.6	134.5	108.5	108.5	127.5	102.4	102.4	120.5	95.8	95.8	112.9	
			SHC	99.8	120.6	141.4	94.7	114.6	134.5	89.5	108.5	127.5	84.3	102.4	120.5	78.8	95.8	112.9	
	67		TC	125.7	125.7	134.1	118.4	118.4	130.7	111.2	111.2	127.1	103.9	103.9	123.4	96.4	96.4	119.3	
			SHC	83.3	108.7	134.1	79.9	105.2	130.7	76.5	101.8	127.1	73.1	98.3	123.4	69.5	94.5	119.3	
	72	TC	138.5	138.5	138.5	130.3	130.3	130.3	122.3	122.3	122.3	114.3	114.3	114.3	105.9	105.9	105.9		
		SHC	58.5	84.1	109.8	55.2	80.8	106.5	52.0	77.5	103.2	48.7	74.3	99.8	45.3	70.9	96.4		
	76	TC	-	149.7	149.7	-	141.0	141.0	-	132.4	132.4	-	123.8	123.8	-	115.0	115.0		
		SHC	-	64.2	90.0	-	60.8	86.7	-	57.6	83.4	-	54.3	80.0	-	51.0	76.7		
	5550 Cfm	EAT (wb)	58	TC	124.7	124.7	140.8	118.4	118.4	133.7	112.0	112.0	126.7	105.6	105.6	119.5	98.8	98.8	111.9
				SHC	108.6	124.7	140.8	103.0	118.4	133.7	97.4	112.0	126.7	91.7	105.6	119.5	85.6	98.8	111.9
62			TC	124.8	124.8	146.3	118.5	118.5	138.9	112.1	112.1	131.7	105.7	105.7	124.3	98.9	98.9	116.4	
			SHC	103.4	124.8	146.3	97.9	118.5	138.9	92.5	112.1	131.7	87.1	105.7	124.3	81.2	98.9	116.4	
67			TC	127.7	127.7	145.2	120.3	120.3	141.4	113.0	113.0	137.5	106.0	106.0	132.8	99.2	99.2	124.5	
			SHC	88.3	116.8	145.2	84.8	113.1	141.4	81.4	109.4	137.5	77.5	105.2	132.8	72.3	98.4	124.5	
72		TC	140.2	140.2	140.2	131.8	131.8	131.8	123.6	123.6	123.6	115.4	115.4	115.4	107.0	107.0	107.0		
		SHC	60.6	89.4	118.2	57.2	86.0	114.8	54.0	82.7	111.3	50.7	79.4	108.0	47.3	76.0	104.6		
76		TC	-	151.5	151.5	-	142.6	142.6	-	133.9	133.9	-	125.1	125.1	-	116.1	116.1		
		SHC	-	67.0	95.8	-	63.6	92.4	-	60.3	89.1	-	56.9	85.8	-	53.6	82.4		
6150 Cfm		EAT (wb)	58	TC	128.0	128.0	144.4	121.4	121.4	137.1	114.9	114.9	129.8	108.1	108.1	122.4	101.1	101.1	114.6
				SHC	111.5	128.0	144.4	105.6	121.4	137.1	99.8	114.9	129.8	93.9	108.1	122.4	87.7	101.1	114.6
	62		TC	128.1	128.1	150.1	121.5	121.5	142.4	115.0	115.0	134.9	108.2	108.2	127.2	101.2	101.2	119.1	
			SHC	106.1	128.1	150.1	100.4	121.5	142.4	94.9	115.0	134.9	89.2	108.2	127.2	83.2	101.2	119.1	
	67		TC	129.5	129.5	154.6	122.1	122.1	150.3	115.2	115.2	144.2	108.5	108.5	136.0	101.3	101.3	128.2	
			SHC	92.7	123.7	154.6	89.1	119.7	150.3	84.7	114.5	144.2	79.6	107.7	136.0	74.4	101.3	128.2	
	72	TC	141.5	141.5	141.5	133.0	133.0	133.0	124.7	124.7	124.7	116.4	116.4	116.4	107.7	107.7	111.9		
		SHC	62.5	94.1	125.6	59.1	90.7	122.2	55.8	87.3	118.8	52.5	83.9	115.4	49.1	80.5	111.9		
	76	TC	-	152.9	152.9	-	143.8	143.8	-	134.9	134.9	-	126.1	126.1	-	116.9	116.9		
		SHC	-	69.3	101.1	-	66.0	97.6	-	62.7	94.3	-	59.3	90.9	-	56.0	87.5		

LEGEND:

- - Do not operate
- Cfm - Cubic feet per minute (supply air)
- EAT (db) - Entering Air Temperature (dry bulb)
- EAT (wb) - Entering Air Temperature (wet bulb)
- SHC - Sensible Heat Capacity (1000 Btuh) Gross
- TC - Total Capacity (1000 Btuh) Gross

Table 18 – COOLING CAPACITIES - THIRD STAGE, FULL LOAD

15 TONS

17 SIZE			AMBIENT TEMPERATURE																
			85°F			95°F			105°F			115°F			125°F				
			EAT (db)			EAT (db)			EAT (db)			EAT (db)			EAT (db)				
			75	80	85	75	80	85	75	80	85	75	80	85	75	80	85		
4500 Cfm	EAT (wb)	58	TC	156.8	156.8	177.9	148.6	148.6	169.1	139.9	139.9	159.6	130.7	130.7	149.5	120.9	120.9	138.7	
			SHC	135.6	156.8	177.9	128.1	148.6	169.1	120.3	139.9	159.6	111.9	130.7	149.5	103.1	120.9	138.7	
		62	TC	164.6	164.6	169.4	154.6	154.6	163.2	144.2	144.2	157.0	133.3	133.3	150.3	121.8	121.8	143.0	
			SHC	122.2	145.8	169.4	116.1	139.7	163.2	109.9	133.4	157.0	103.4	126.8	150.3	96.5	119.7	143.0	
		67	TC	182.6	182.6	182.6	171.8	171.8	171.8	160.6	160.6	160.6	148.7	148.7	148.7	136.1	136.1	136.1	
			SHC	100.4	124.1	147.8	94.4	118.1	141.8	88.2	111.9	135.6	81.9	105.5	129.2	75.3	98.9	122.6	
	72	TC	202.4	202.4	202.4	191.0	191.0	191.0	179.0	179.0	179.0	166.4	166.4	166.4	153.0	153.0	153.0		
		SHC	78.1	102.0	125.9	72.2	96.0	119.8	66.1	89.9	113.8	59.9	83.7	107.4	53.3	77.1	100.9		
	76	TC	-	219.3	219.3	-	207.1	207.1	-	194.5	194.5	-	181.2	181.2	-	167.1	167.1		
		SHC	-	83.8	107.9	-	77.9	102.0	-	71.9	96.0	-	65.6	89.8	-	59.3	83.5		
	5250 Cfm	EAT (wb)	58	TC	166.9	166.9	189.3	158.1	158.1	179.8	149.0	149.0	169.7	139.2	139.2	159.0	128.8	128.8	147.5
				SHC	144.6	166.9	189.3	136.6	158.1	179.8	128.3	149.0	169.7	119.5	139.2	159.0	110.1	128.8	147.5
62			TC	170.8	170.8	187.4	160.6	160.6	181.0	150.1	150.1	174.1	139.4	139.4	165.8	129.0	129.0	154.0	
			SHC	133.0	160.2	187.4	126.8	153.9	181.0	120.3	147.2	174.1	113.1	139.4	165.8	103.9	129.0	154.0	
67			TC	188.4	188.4	188.4	177.2	177.2	177.2	165.4	165.4	165.4	153.1	153.1	153.1	140.0	140.0	140.0	
			SHC	107.5	134.9	162.3	101.4	128.8	156.2	95.2	122.6	149.9	88.6	116.0	143.4	81.9	109.2	136.6	
72		TC	208.4	208.4	208.4	196.4	196.4	196.4	184.0	184.0	184.0	170.8	170.8	170.8	157.0	157.0	157.0		
		SHC	81.5	109.1	136.6	75.5	103.0	130.6	69.3	96.8	124.3	62.9	90.4	117.9	56.4	83.8	111.2		
76		TC	-	225.1	225.1	-	212.6	212.6	-	199.5	199.5	-	185.5	185.5	-	170.9	170.9		
		SHC	-	87.9	116.1	-	81.9	110.0	-	75.9	103.7	-	69.4	97.3	-	62.9	90.7		
6000 Cfm		EAT (wb)	58	TC	175.4	175.4	198.8	166.2	166.2	188.7	156.5	156.5	178.0	146.2	146.2	166.7	135.2	135.2	154.7
				SHC	152.1	175.4	198.8	143.7	166.2	188.7	134.9	156.5	178.0	125.7	146.2	166.7	115.7	135.2	154.7
	62		TC	176.5	176.5	204.0	166.3	166.3	196.4	156.7	156.7	185.4	146.3	146.3	173.8	135.4	135.4	161.4	
			SHC	143.0	173.6	204.0	136.3	166.3	196.4	127.8	156.7	185.4	119.0	146.3	173.8	109.4	135.4	161.4	
	67		TC	192.8	192.8	192.8	181.3	181.3	181.3	169.2	169.2	169.2	156.6	156.6	156.9	143.2	143.2	150.0	
			SHC	114.2	145.2	176.2	108.0	138.9	169.9	101.6	132.6	163.5	95.1	126.0	156.9	88.2	119.1	150.0	
	72	TC	212.8	212.8	212.8	200.5	200.5	200.5	187.7	187.7	187.7	174.2	174.2	174.2	159.9	159.9	159.9		
		SHC	84.5	115.7	146.8	78.4	109.5	140.7	72.2	103.3	134.4	65.7	96.7	127.8	59.1	90.0	121.0		
	76	TC	-	229.7	229.7	-	216.6	216.6	-	203.3	203.3	-	189.2	189.2	-	173.8	173.8		
		SHC	-	91.7	123.3	-	85.6	117.1	-	79.4	110.9	-	72.9	104.3	-	66.2	97.5		
	6750 Cfm	EAT (wb)	58	TC	182.5	182.5	206.7	172.8	172.8	196.1	162.6	162.6	185.0	152.0	152.0	173.3	140.6	140.6	160.7
				SHC	158.3	182.5	206.7	149.6	172.8	196.1	140.4	162.6	185.0	130.7	152.0	173.3	120.5	140.6	160.7
62			TC	182.7	182.7	215.1	173.0	173.0	204.1	162.8	162.8	192.7	152.2	152.2	180.5	140.8	140.8	167.6	
			SHC	150.4	182.7	215.1	142.0	173.0	204.1	133.1	162.8	192.7	123.8	152.2	180.5	114.0	140.8	167.6	
67			TC	196.4	196.4	196.4	184.5	184.5	184.5	172.3	172.3	176.7	159.4	159.4	169.8	145.8	145.8	162.7	
			SHC	120.5	155.0	189.5	114.2	148.7	183.1	107.8	142.3	176.7	101.2	135.5	169.8	94.3	128.5	162.7	
72		TC	216.4	216.4	216.4	203.7	203.7	203.7	190.6	190.6	190.6	176.8	176.8	176.8	162.2	162.2	162.2		
		SHC	87.3	122.0	156.6	81.1	115.7	150.3	74.8	109.4	143.9	68.3	102.8	137.3	61.5	96.0	130.5		
76		TC	-	233.3	233.3	-	220.0	220.0	-	206.1	206.1	-	191.7	191.7	-	176.1	176.1		
		SHC	-	95.1	130.3	-	88.9	123.9	-	82.7	117.6	-	76.1	111.0	-	69.3	103.9		
7500 Cfm		EAT (wb)	58	TC	188.5	188.5	213.3	178.4	178.4	202.4	167.9	167.9	190.8	156.9	156.9	178.6	145.1	145.1	165.7
				SHC	163.6	188.5	213.3	154.5	178.4	202.4	145.1	167.9	190.8	135.1	156.9	178.6	124.5	145.1	165.7
	62		TC	188.7	188.7	221.9	178.6	178.6	210.6	168.1	168.1	198.7	157.1	157.1	186.1	145.3	145.3	172.8	
			SHC	155.5	188.7	221.9	146.7	178.6	210.6	137.6	168.1	198.7	127.9	157.1	186.1	117.8	145.3	172.8	
	67		TC	199.3	199.3	202.5	187.3	187.3	196.0	174.8	174.8	189.2	161.9	161.9	182.2	148.2	148.2	174.7	
			SHC	126.6	164.5	202.5	120.2	158.1	196.0	113.7	151.5	189.2	107.0	144.6	182.2	99.8	137.3	174.7	
	72	TC	219.2	219.2	219.2	206.3	206.3	206.3	193.0	193.0	193.0	178.9	178.9	178.9	164.1	164.1	164.1		
		SHC	89.9	128.0	166.0	83.7	121.7	159.7	77.3	115.2	153.3	70.8	108.6	146.5	64.0	101.8	139.6		
	76	TC	-	236.1	236.1	-	222.6	222.6	-	208.6	208.6	-	193.8	193.8	-	177.8	177.8		
		SHC	-	98.4	136.9	-	92.1	130.5	-	85.8	124.0	-	79.3	117.3	-	72.3	110.2		

LEGEND:

- - Do not operate
- Cfm - Cubic feet per minute (supply air)
- EAT (db) - Entering Air Temperature (dry bulb)
- EAT (wb) - Entering Air Temperature (wet bulb)
- SHC - Sensible Heat Capacity (1000 Btuh) Gross
- TC - Total Capacity (1000 Btuh) Gross

48LC*A17 REHEAT MODE #1 CAPACITIES (MBTUH), STANDARD UNITS

Reheat-1 (Subcooler Mode)		AIR ENTERING EVAPORATOR - SCFM/BF (80db)								
		4500			6000			7500		
Outdoor Air Temp ° F		Air Entering Evaporator -- Ewb (F)								
		72	67	62	72	67	62	72	67	62
75	TC	207	187	167	217	198	180	225	205	189
	SHC	95	116	137	107	137	164	120	155	189
	kW	10.1	9.9	9.6	10.1	10.0	9.8	10.2	10.0	9.9
85	TC	190	175	157	206	186	168	212	186	173
	SHC	79	106	128	98	126	154	109	138	173
	kW	11.0	10.9	10.7	11.3	11.0	10.8	11.3	10.9	10.8
95	TC	173	163	146	192	173	157	192	180	165
	SHC	64	95	117	85	114	143	90	132	165
	kW	12.1	12.1	11.9	12.5	12.2	12.0	12.3	12.3	12.1
105	TC	169	151	135	179	160	145	185	166	153
	SHC	61	84	107	73	102	132	84	120	153
	kW	13.7	13.4	13.2	13.8	13.6	13.4	13.9	13.6	13.5
115	TC	156	138	123	165	147	132	170	152	140
	SHC	49	72	96	60	90	120	71	107	140
	kW	15.2	14.9	14.7	15.3	15.1	14.8	15.4	15.1	15.0
125	TC	142	125	110	150	133	118	155	138	126
	SHC	37	60	85	47	78	108	57	94	126
	kW	16.9	16.6	16.3	17.0	16.7	16.5	17.1	16.8	16.6

LEGEND AND NOTES

- kW --- Compressor Power Input
- SHC --- Sensible Heat Capacity (1000 Btuh) Gross
- TC --- Total Capacity (1000 Btuh) Gross

48LC*A17 REHEAT MODE #2 CAPACITIES (MBTUH), STANDARD UNITS

Reheat-2 (Hot Gas Reheat Mode)		AIR ENTERING EVAPORATOR - SCFM/BF (80db)								
		4500			6000			7500		
Outdoor Air Temp ° F		Air Entering Evaporator -- Ewb (F)								
		62.5	64	65.3	62.5	64	65.3	62.5	64	65.3
80	TC	69	72	74	72	75	77	74	77	79
	SHC	16	8	0	28	17	8	41	28	17
	kW	12.6	12.8	12.9	12.7	12.9	13.0	12.8	12.9	13.0
75	TC	74	77	79	77	80	83	79	82	85
	SHC	21	12	5	33	22	13	46	33	22
	kW	12.1	12.2	12.3	12.2	12.3	12.4	12.3	12.4	12.5
70	TC	79	82	84	82	85	88	85	87	90
	SHC	26	17	10	38	27	18	51	38	27
	kW	11.6	11.7	11.8	11.7	11.8	11.9	11.7	11.9	12.0
60	TC	88	91	94	92	96	98	95	98	101
	SHC	35	27	19	48	37	28	61	48	37
	kW	10.6	10.7	10.9	10.7	10.8	11.0	10.8	10.9	11.0
50	TC	98	102	104	103	106	109	106	109	112
	SHC	45	37	30	58	48	39	71	59	48
	kW	9.8	9.9	10.1	9.9	10.1	10.2	10.0	10.1	10.2
40	TC	108	112	115	113	117	120	116	120	123
	SHC	55	47	41	69	59	50	83	71	60
	kW	9.1	9.3	9.4	9.3	9.4	9.5	9.3	9.5	9.6

LEGEND AND NOTES

- kW --- Compressor Power Input
- SHC --- Sensible Heat Capacity (1000 Btuh) Gross
- TC --- Total Capacity (1000 Btuh) Gross

Table 20 – COOLING CAPACITIES - FIRST STAGE, PART LOAD

17.5 TONS

20 SIZE			AMBIENT TEMPERATURE																
			85°F			95°F			105°F			115°F			125°F				
			EAT (db)			EAT (db)			EAT (db)			EAT (db)			EAT (db)				
			75	80	85	75	80	85	75	80	85	75	80	85	75	80	85		
2750 Cfm	EAT (wb)	58	TC	92.1	92.1	104.1	88.5	88.5	100.0	84.6	84.6	95.7	80.4	80.4	91.1	76.0	76.0	86.1	
			SHC	80.1	92.1	104.1	76.9	88.5	100.0	73.5	84.6	95.7	69.8	80.4	91.1	65.8	76.0	86.1	
		62	TC	95.0	95.0	102.0	90.5	90.5	99.5	85.8	85.8	96.9	80.9	80.9	93.9	76.1	76.1	89.6	
			SHC	73.5	87.8	102.0	71.2	85.4	99.5	68.6	82.8	96.9	65.9	80.0	93.9	62.5	76.1	89.6	
		67	TC	104.3	104.3	104.3	99.5	99.5	99.5	94.4	94.4	94.4	88.8	88.8	88.8	83.1	83.1	83.1	
			SHC	59.9	74.2	88.6	57.6	72.0	86.3	55.3	69.6	83.9	52.7	67.1	81.4	50.1	64.4	78.8	
	72	TC	115.1	115.1	115.1	109.9	109.9	109.9	104.4	104.4	104.4	98.5	98.5	98.5	92.2	92.2	92.2		
		SHC	45.9	60.4	74.8	43.7	58.1	72.5	41.3	55.8	70.2	38.9	53.3	67.7	36.4	50.7	65.1		
	76	TC	-	124.1	124.1	-	118.8	118.8	-	112.9	112.9	-	106.7	106.7	-	99.9	99.9		
		SHC	-	49.0	63.8	-	46.8	61.5	-	44.5	59.2	-	42.1	56.6	-	39.5	54.1		
	3250 Cfm	EAT (wb)	58	TC	97.5	97.5	110.2	93.7	93.7	105.9	89.5	89.5	101.2	85.0	85.0	96.2	80.2	80.2	90.9
				SHC	84.9	97.5	110.2	81.4	93.7	105.9	77.8	89.5	101.2	73.8	85.0	96.2	69.6	80.2	90.9
62			TC	98.3	98.3	112.6	94.0	94.0	109.6	89.6	89.6	105.2	85.1	85.1	100.0	80.3	80.3	94.6	
			SHC	80.0	96.3	112.6	77.2	93.4	109.6	73.9	89.6	105.2	70.1	85.1	100.0	66.1	80.3	94.6	
67			TC	107.3	107.3	107.3	102.3	102.3	102.3	96.9	96.9	96.9	91.2	91.2	91.2	85.1	85.1	87.6	
			SHC	64.2	80.9	97.7	61.9	78.6	95.4	59.5	76.1	92.9	56.9	73.6	90.3	54.2	70.9	87.6	
72		TC	118.1	118.1	118.1	112.8	112.8	112.8	107.1	107.1	107.1	100.9	100.9	100.9	94.3	94.3	94.3		
		SHC	47.8	64.6	81.4	45.6	62.4	79.2	43.2	60.0	76.7	40.8	57.5	74.2	38.1	54.9	71.6		
76		TC	-	127.3	127.3	-	121.7	121.7	-	115.5	115.5	-	109.1	109.1	-	102.1	102.1		
		SHC	-	51.4	68.4	-	49.1	66.2	-	46.8	63.8	-	44.4	61.2	-	41.7	58.6		
3700 Cfm		EAT (wb)	58	TC	101.6	101.6	114.7	97.5	97.5	110.2	93.1	93.1	105.3	88.4	88.4	100.0	83.4	83.4	94.4
				SHC	88.4	101.6	114.7	84.8	97.5	110.2	80.9	93.1	105.3	76.7	88.4	100.0	72.3	83.4	94.4
	62		TC	101.7	101.7	119.1	97.6	97.6	114.5	93.2	93.2	109.5	88.4	88.4	104.0	83.5	83.5	98.2	
			SHC	84.1	101.7	119.1	80.6	97.6	114.5	76.9	93.2	109.5	72.9	88.4	104.0	68.7	83.5	98.2	
	67		TC	109.3	109.3	109.3	104.1	104.1	104.1	98.7	98.7	100.5	92.8	92.8	97.8	86.6	86.6	95.0	
			SHC	67.9	86.7	105.5	65.5	84.3	103.1	63.1	81.8	100.5	60.5	79.1	97.8	57.7	76.3	95.0	
	72	TC	120.2	120.2	120.2	114.7	114.7	114.7	108.8	108.8	108.8	102.5	102.5	102.5	95.7	95.7	95.7		
		SHC	49.3	68.3	87.2	47.1	66.0	84.8	44.8	63.6	82.4	42.2	61.0	79.9	39.6	58.4	77.1		
	76	TC	-	129.5	129.5	-	123.6	123.6	-	117.4	117.4	-	110.7	110.7	-	103.5	103.5		
		SHC	-	53.3	72.4	-	51.1	70.2	-	48.8	67.7	-	46.2	65.1	-	43.6	62.4		
	4150 Cfm	EAT (wb)	58	TC	105.0	105.0	118.6	100.7	100.7	113.8	96.1	96.1	108.7	91.3	91.3	103.3	86.0	86.0	97.4
				SHC	91.5	105.0	118.6	87.7	100.7	113.8	83.7	96.1	108.7	79.3	91.3	103.3	74.7	86.0	97.4
62			TC	105.1	105.1	123.1	100.8	100.8	118.3	96.2	96.2	113.0	91.4	91.4	107.3	86.1	86.1	101.3	
			SHC	87.0	105.1	123.1	83.4	100.8	118.3	79.6	96.2	113.0	75.4	91.4	107.3	71.0	86.1	101.3	
67			TC	111.0	111.0	112.9	105.7	105.7	110.5	100.1	100.1	107.8	94.2	94.2	105.0	87.9	87.9	102.0	
			SHC	71.3	92.1	112.9	68.9	89.7	110.5	66.4	87.2	107.8	63.8	84.3	105.0	60.9	81.4	102.0	
72		TC	121.8	121.8	121.8	116.2	116.2	116.2	110.2	110.2	110.2	103.7	103.7	103.7	96.8	96.8	96.8		
		SHC	50.8	71.8	92.6	48.6	69.4	90.3	46.1	67.0	87.8	43.6	64.4	85.2	41.0	61.7	82.5		
76		TC	-	131.1	131.1	-	125.2	125.2	-	118.8	118.8	-	111.9	111.9	-	104.6	104.6		
		SHC	-	55.2	76.2	-	52.9	73.9	-	50.5	71.5	-	48.0	68.8	-	45.2	66.1		
4600 Cfm		EAT (wb)	58	TC	107.9	107.9	121.9	103.5	103.5	117.0	98.8	98.8	111.6	93.7	93.7	106.0	88.3	88.3	99.9
				SHC	94.0	107.9	121.9	90.2	103.5	117.0	85.9	98.8	111.6	81.4	93.7	106.0	76.6	88.3	99.9
	62		TC	108.0	108.0	126.7	103.6	103.6	121.6	98.9	98.9	116.0	93.8	93.8	110.2	88.3	88.3	103.9	
			SHC	89.5	108.0	126.7	85.7	103.6	121.6	81.7	98.9	116.0	77.4	93.8	110.2	72.8	88.3	103.9	
	67		TC	112.3	112.3	120.0	107.1	107.1	117.5	101.4	101.4	114.7	95.5	95.5	111.7	89.2	89.2	108.2	
			SHC	74.6	97.3	120.0	72.2	94.9	117.5	69.6	92.1	114.7	66.9	89.3	111.7	63.9	86.1	108.2	
	72	TC	123.1	123.1	123.1	117.4	117.4	117.4	111.2	111.2	111.2	104.7	104.7	104.7	97.7	97.7	97.7		
		SHC	52.2	75.1	97.9	49.9	72.7	95.6	47.5	70.2	93.0	44.9	67.7	90.4	42.2	64.9	87.6		
	76	TC	-	132.5	132.5	-	126.5	126.5	-	119.9	119.9	-	112.9	112.9	-	105.5	105.5		
		SHC	-	56.9	80.0	-	54.6	77.5	-	52.2	75.0	-	49.6	72.3	-	46.9	69.5		

LEGEND:

- - Do not operate
- Cfm - Cubic feet per minute (supply air)
- EAT (db) - Entering Air Temperature (dry bulb)
- EAT (wb) - Entering Air Temperature (wet bulb)
- SHC - Sensible Heat Capacity (1000 Btuh) Gross
- TC - Total Capacity (1000 Btuh) Gross

Table 21 – COOLING CAPACITIES - SECOND STAGE, PART LOAD

17.5 TONS

20 SIZE			AMBIENT TEMPERATURE																
			85°F			95°F			105°F			115°F			125°F				
			EAT (db)			EAT (db)			EAT (db)			EAT (db)			EAT (db)				
			75	80	85	75	80	85	75	80	85	75	80	85	75	80	85		
3250 Cfm	EAT (wb)	58	TC	101.8	101.8	115.2	96.7	96.7	109.7	91.7	91.7	104.0	86.3	86.3	98.2	80.5	80.5	91.8	
			SHC	88.3	101.8	115.2	83.8	96.7	109.7	79.2	91.7	104.0	74.4	86.3	98.2	69.2	80.5	91.8	
		62	TC	103.9	103.9	115.2	97.9	97.9	111.5	92.0	92.0	107.5	86.4	86.4	102.3	80.6	80.6	95.7	
			SHC	81.9	98.6	115.2	78.4	95.0	111.5	74.7	91.2	107.5	70.5	86.4	102.3	65.5	80.6	95.7	
		67	TC	114.8	114.8	114.8	108.0	108.0	108.0	101.3	101.3	101.3	94.4	94.4	94.4	87.2	87.2	87.2	
			SHC	66.3	83.2	100.0	62.8	79.7	96.6	59.5	76.3	93.2	56.0	72.8	89.7	52.5	69.2	86.1	
	72	TC	127.2	127.2	127.2	119.8	119.8	119.8	112.5	112.5	112.5	105.1	105.1	105.1	97.3	97.3	97.3		
		SHC	50.2	67.2	84.2	46.8	63.8	80.7	43.4	60.4	77.3	40.0	56.9	73.8	36.5	53.3	70.3		
	76	TC	-	137.8	137.8	-	129.8	129.8	-	122.0	122.0	-	114.1	114.1	-	105.7	105.7		
		SHC	-	54.2	71.6	-	50.7	68.0	-	47.3	64.5	-	43.9	61.0	-	40.4	57.4		
	3800 Cfm	EAT (wb)	58	TC	107.6	107.6	121.8	102.1	102.1	115.7	96.6	96.6	109.7	91.0	91.0	103.4	84.9	84.9	96.7
				SHC	93.4	107.6	121.8	88.5	102.1	115.7	83.6	96.6	109.7	78.5	91.0	103.4	73.0	84.9	96.7
62			TC	107.9	107.9	126.2	102.3	102.3	120.4	96.7	96.7	114.2	91.1	91.1	107.7	85.0	85.0	100.8	
			SHC	88.5	107.3	126.2	84.0	102.3	120.4	79.3	96.7	114.2	74.4	91.1	107.7	69.2	85.0	100.8	
67			TC	117.8	117.8	117.8	110.8	110.8	110.8	103.7	103.7	103.7	96.6	96.6	99.3	89.2	89.2	95.5	
			SHC	71.0	90.5	109.9	67.5	86.9	106.4	64.0	83.4	102.9	60.5	79.9	99.3	56.8	76.1	95.5	
72		TC	130.5	130.5	130.5	122.7	122.7	122.7	115.1	115.1	115.1	107.3	107.3	107.3	99.3	99.3	99.3		
		SHC	52.4	71.9	91.5	48.8	68.3	87.8	45.3	64.8	84.3	41.9	61.3	80.8	38.3	57.7	77.2		
76		TC	-	141.0	141.0	-	132.7	132.7	-	124.5	124.5	-	116.2	116.2	-	107.6	107.6		
		SHC	-	56.7	76.6	-	53.2	73.0	-	49.7	69.4	-	46.2	65.9	-	42.7	62.2		
4300 Cfm		EAT (wb)	58	TC	112.0	112.0	126.7	106.2	106.2	120.3	100.4	100.4	114.0	94.5	94.5	107.3	88.1	88.1	100.3
				SHC	97.3	112.0	126.7	92.1	106.2	120.3	87.0	100.4	114.0	81.6	94.5	107.3	76.0	88.1	100.3
	62		TC	112.1	112.1	131.7	106.3	106.3	125.2	100.5	100.5	118.6	94.6	94.6	111.7	88.2	88.2	104.5	
			SHC	92.4	112.1	131.7	87.5	106.3	125.2	82.5	100.5	118.6	77.3	94.6	111.7	72.0	88.2	104.5	
	67		TC	120.0	120.0	120.0	112.7	112.7	114.8	105.6	105.6	111.2	98.4	98.4	107.4	90.8	90.8	103.5	
			SHC	75.0	96.7	118.5	71.4	93.1	114.8	67.9	89.5	111.2	64.3	85.8	107.4	60.5	82.0	103.5	
	72	TC	132.6	132.6	132.6	124.6	124.6	124.6	116.8	116.8	116.8	108.9	108.9	108.9	100.6	100.6	100.6		
		SHC	54.0	75.9	97.7	50.5	72.2	94.1	47.0	68.7	90.5	43.5	65.2	86.9	39.9	61.5	83.2		
	76	TC	-	143.2	143.2	-	134.6	134.6	-	126.2	126.2	-	117.7	117.7	-	109.0	109.0		
		SHC	-	58.9	81.0	-	55.3	77.3	-	51.8	73.6	-	48.2	70.0	-	44.6	66.2		
	4850 Cfm	EAT (wb)	58	TC	116.1	116.1	131.3	110.0	110.0	124.6	103.9	103.9	117.9	97.7	97.7	111.0	91.1	91.1	103.6
				SHC	100.9	116.1	131.3	95.5	110.0	124.6	90.0	103.9	117.9	84.4	97.7	111.0	78.6	91.1	103.6
62			TC	116.2	116.2	136.5	110.1	110.1	129.6	104.0	104.0	122.7	97.8	97.8	115.5	91.2	91.2	107.9	
			SHC	95.9	116.2	136.5	90.7	110.1	129.6	85.4	104.0	122.7	80.0	97.8	115.5	74.4	91.2	107.9	
67			TC	122.0	122.0	127.4	114.6	114.6	123.6	107.3	107.3	119.8	99.9	99.9	115.9	92.3	92.3	111.6	
			SHC	79.1	103.3	127.4	75.5	99.5	123.6	71.9	95.8	119.8	68.2	92.0	115.9	64.4	87.9	111.6	
72		TC	134.6	134.6	134.6	126.4	126.4	126.4	118.3	118.3	118.3	110.3	110.3	110.3	101.8	101.8	101.8		
		SHC	55.8	80.0	104.2	52.2	76.3	100.5	48.7	72.7	96.9	45.0	69.2	93.3	41.4	65.4	89.5		
76		TC	-	145.2	145.2	-	136.3	136.3	-	127.7	127.7	-	119.0	119.0	-	110.1	110.1		
		SHC	-	61.1	85.5	-	57.4	81.7	-	53.8	78.0	-	50.2	74.3	-	46.5	70.4		
5400 Cfm		EAT (wb)	58	TC	119.6	119.6	135.2	113.2	113.2	128.2	107.0	107.0	121.2	100.4	100.4	114.1	93.6	93.6	106.5
				SHC	103.9	119.6	135.2	98.3	113.2	128.2	92.6	107.0	121.2	86.9	100.4	114.1	80.7	93.6	106.5
	62		TC	119.7	119.7	140.6	113.3	113.3	133.3	107.1	107.1	126.1	100.5	100.5	118.7	93.7	93.7	110.9	
			SHC	98.9	119.7	140.6	93.4	113.3	133.3	87.9	107.1	126.1	82.4	100.5	118.7	76.5	93.7	110.9	
	67		TC	123.7	123.7	135.8	116.2	116.2	131.8	108.8	108.8	127.9	101.5	101.5	123.5	94.1	94.1	118.1	
			SHC	83.1	109.5	135.8	79.3	105.6	131.8	75.6	101.8	127.9	71.8	97.7	123.5	67.5	92.7	118.1	
	72	TC	136.0	136.0	136.0	127.7	127.7	127.7	119.5	119.5	119.5	111.3	111.3	111.3	102.8	102.8	102.8		
		SHC	57.4	83.9	110.6	53.7	80.2	106.8	50.2	76.6	103.1	46.6	73.0	99.4	42.9	69.2	95.6		
	76	TC	-	146.6	146.6	-	137.7	137.7	-	128.9	128.9	-	120.0	120.0	-	111.0	111.0		
		SHC	-	63.1	89.8	-	59.4	86.0	-	55.8	82.2	-	52.1	78.3	-	48.4	74.4		

LEGEND:

- - Do not operate
- Cfm - Cubic feet per minute (supply air)
- EAT (db) - Entering Air Temperature (dry bulb)
- EAT (wb) - Entering Air Temperature (wet bulb)
- SHC - Sensible Heat Capacity (1000 Btuh) Gross
- TC - Total Capacity (1000 Btuh) Gross

Table 22 – COOLING CAPACITIES - THIRD STAGE, FULL LOAD

17.5 TONS

20 SIZE				AMBIENT TEMPERATURE															
				85°F			95°F			105°F			115°F			125°F			
				EAT (db)			EAT (db)			EAT (db)			EAT (db)			EAT (db)			
				75	80	85	75	80	85	75	80	85	75	80	85	75	80	85	
5250 Cfm	EAT (wb)	58	TC	177.4	177.4	201.2	168.6	168.6	191.6	159.3	159.3	181.4	149.7	149.7	170.8	139.3	139.3	159.4	
			SHC	153.6	177.4	201.2	145.6	168.6	191.6	137.2	159.3	181.4	128.5	149.7	170.8	119.1	139.3	159.4	
		62	TC	184.4	184.4	192.2	173.9	173.9	185.7	163.0	163.0	179.1	151.7	151.7	172.2	140.0	140.0	164.5	
			SHC	138.4	165.3	192.2	132.0	158.9	185.7	125.6	152.4	179.1	118.9	145.5	172.2	111.7	138.1	164.5	
		67	TC	202.7	202.7	202.7	191.4	191.4	191.4	179.6	179.6	179.6	167.2	167.2	167.2	154.2	154.2	154.2	
			SHC	112.7	139.7	166.8	106.5	133.6	160.6	100.2	127.2	154.2	93.6	120.6	147.6	87.0	113.9	140.9	
	72	TC	223.1	223.1	223.1	211.2	211.2	211.2	198.6	198.6	198.6	185.4	185.4	185.4	171.8	171.8	171.8		
		SHC	86.6	113.9	141.1	80.5	107.7	135.0	74.3	101.5	128.7	67.9	95.1	122.2	61.3	88.4	115.5		
	76	TC	-	240.5	240.5	-	228.1	228.1	-	215.0	215.0	-	200.9	200.9	-	186.7	186.7		
		SHC	-	92.8	121.0	-	86.9	115.0	-	80.7	108.7	-	74.3	102.1	-	67.8	95.6		
	6150 Cfm	EAT (wb)	58	TC	187.8	187.8	212.8	178.4	178.4	202.6	168.6	168.6	191.8	158.2	158.2	180.5	147.4	147.4	168.5
				SHC	162.7	187.8	212.8	154.2	178.4	202.6	145.4	168.6	191.8	136.1	158.2	180.5	126.4	147.4	168.5
62			TC	190.8	190.8	211.8	180.2	180.2	205.0	169.3	169.3	197.5	158.5	158.5	188.2	147.6	147.6	175.7	
			SHC	150.1	181.0	211.8	143.6	174.3	205.0	136.7	167.1	197.5	128.9	158.5	188.2	119.4	147.6	175.7	
67			TC	208.3	208.3	208.3	196.5	196.5	196.5	184.3	184.3	184.3	171.5	171.5	171.5	158.2	158.2	158.2	
			SHC	120.3	151.5	182.7	114.1	145.3	176.5	107.6	138.8	170.0	101.0	132.1	163.3	94.2	125.3	156.4	
72		TC	228.8	228.8	228.8	216.5	216.5	216.5	203.3	203.3	203.3	189.8	189.8	189.8	175.8	175.8	175.8		
		SHC	90.1	121.5	152.9	83.9	115.2	146.6	77.5	108.8	140.2	71.1	102.4	133.6	64.4	95.6	126.8		
76		TC	-	246.4	246.4	-	233.5	233.5	-	220.0	220.0	-	205.3	205.3	-	190.6	190.6		
		SHC	-	97.1	129.4	-	91.1	123.1	-	84.8	116.8	-	78.3	110.1	-	71.7	103.4		
7000 Cfm		EAT (wb)	58	TC	195.8	195.8	221.7	186.0	186.0	211.0	175.7	175.7	199.7	164.9	164.9	187.8	153.6	153.6	175.3
				SHC	169.7	195.8	221.7	161.0	186.0	211.0	151.7	175.7	199.7	142.0	164.9	187.8	131.7	153.6	175.3
	62		TC	196.4	196.4	228.2	186.1	186.1	219.6	175.9	175.9	208.0	165.1	165.1	195.7	153.8	153.8	182.8	
			SHC	160.0	194.1	228.2	152.7	186.1	219.6	143.8	175.9	208.0	134.5	165.1	195.7	124.6	153.8	182.8	
	67		TC	212.4	212.4	212.4	200.4	200.4	200.4	187.9	187.9	187.9	174.8	174.8	177.5	161.2	161.2	170.3	
			SHC	127.1	162.1	197.2	120.8	155.8	190.8	114.3	149.3	184.3	107.5	142.4	177.5	100.7	135.5	170.3	
	72	TC	233.0	233.0	233.0	220.4	220.4	220.4	206.8	206.8	206.8	193.0	193.0	193.0	178.6	178.6	178.6		
		SHC	93.0	128.2	163.4	86.9	122.0	157.1	80.3	115.4	150.5	73.8	108.8	143.8	67.2	102.1	137.1		
	76	TC	-	250.8	250.8	-	237.4	237.4	-	223.2	223.2	-	208.7	208.7	-	193.5	193.5		
		SHC	-	100.8	136.8	-	94.7	130.6	-	88.2	124.0	-	81.8	117.4	-	75.2	110.6		
	7900 Cfm	EAT (wb)	58	TC	202.8	202.8	229.6	192.7	192.7	218.4	181.9	181.9	206.7	170.7	170.7	194.3	158.9	158.9	181.4
				SHC	176.0	202.8	229.6	166.8	192.7	218.4	157.2	181.9	206.7	147.1	170.7	194.3	136.5	158.9	181.4
62			TC	203.1	203.1	238.9	192.9	192.9	227.3	182.1	182.1	215.2	170.8	170.8	202.4	159.0	159.0	189.0	
			SHC	167.2	203.1	238.9	158.3	192.9	227.3	149.1	182.1	215.2	139.3	170.8	202.4	129.1	159.0	189.0	
67			TC	215.9	215.9	215.9	203.7	203.7	205.4	190.9	190.9	198.7	177.6	177.6	191.6	163.9	163.9	184.2	
			SHC	134.0	173.0	212.0	127.6	166.5	205.4	121.0	159.8	198.7	114.2	152.9	191.6	107.2	145.7	184.2	
72		TC	236.6	236.6	236.6	223.7	223.7	223.7	209.7	209.7	209.7	195.6	195.6	195.6	181.0	181.0	181.0		
		SHC	95.9	135.0	174.1	89.7	128.7	167.8	83.1	122.1	161.1	76.5	115.4	154.3	69.8	108.6	147.4		
76		TC	-	254.1	254.1	-	240.5	240.5	-	226.3	226.3	-	211.5	211.5	-	196.0	196.0		
		SHC	-	104.4	144.3	-	98.2	138.0	-	91.8	131.4	-	85.3	124.7	-	78.5	117.7		
8750 Cfm		EAT (wb)	58	TC	208.5	208.5	236.0	197.9	197.9	224.3	187.0	187.0	212.3	175.3	175.3	199.4	163.2	163.2	186.1
				SHC	181.1	208.5	236.0	171.5	197.9	224.3	161.7	187.0	212.3	151.1	175.3	199.4	140.3	163.2	186.1
	62		TC	208.7	208.7	245.4	198.1	198.1	233.4	187.1	187.1	220.9	175.4	175.4	207.7	163.3	163.3	193.9	
			SHC	172.0	208.7	245.4	162.8	198.1	233.4	153.3	187.1	220.9	143.2	175.4	207.7	132.7	163.3	193.9	
	67		TC	218.7	218.7	225.2	206.3	206.3	218.5	193.4	193.4	211.6	180.0	180.0	204.2	166.1	166.1	196.4	
			SHC	140.1	182.7	225.2	133.7	176.1	218.5	126.9	169.3	211.6	120.0	162.0	204.2	112.8	154.5	196.4	
	72	TC	239.3	239.3	239.3	226.1	226.1	226.1	212.4	212.4	212.4	197.5	197.5	197.5	182.8	182.8	182.8		
		SHC	98.5	141.2	183.9	92.1	134.8	177.5	85.7	128.3	170.8	79.0	121.4	163.9	72.2	114.6	156.9		
	76	TC	-	256.9	256.9	-	243.1	243.1	-	228.5	228.5	-	213.5	213.5	-	197.8	197.8		
		SHC	-	107.7	151.1	-	101.5	144.7	-	95.0	138.1	-	88.3	131.2	-	81.6	124.1		

LEGEND:

- - Do not operate
- Cfm - Cubic feet per minute (supply air)
- EAT (db) - Entering Air Temperature (dry bulb)
- EAT (wb) - Entering Air Temperature (wet bulb)
- SHC - Sensible Heat Capacity (1000 Btuh) Gross
- TC - Total Capacity (1000 Btuh) Gross

48LC*A20 REHEAT MODE #1 CAPACITIES (MBTUH), STANDARD UNITS

Reheat-1 (Subcooler Mode)		AIR ENTERING EVAPORATOR - SCFM/BF (80db)								
		5250			7000			8750		
Outdoor Air Temp ° F		Air Entering Evaporator -- Ewb (F)								
		72	67	62	72	67	62	72	67	62
75	TC	234	210	189	246	223	202	254	231	215
	SHC	106	131	157	123	157	189	138	180	215
	kW	11.6	11.2	10.9	11.8	11.4	11.1	11.9	11.5	11.3
85	TC	219	196	176	230	208	189	238	215	200
	SHC	93	119	145	109	143	176	123	165	200
	kW	12.7	12.4	12.1	12.9	12.6	12.3	13.0	12.7	12.5
95	TC	204	182	163	214	193	175	221	199	184
	SHC	79	106	132	94	129	163	108	150	184
	kW	14.0	13.7	13.4	14.2	13.9	13.6	14.3	14.0	13.7
105	TC	188	167	149	197	177	160	204	183	170
	SHC	64	91	120	78	114	149	92	135	170
	kW	15.5	15.1	14.8	15.7	15.3	15.0	15.8	15.4	15.2
115	TC	172	152	135	180	161	145	186	166	154
	SHC	50	78	106	62	99	135	75	120	154
	kW	17.2	16.8	16.5	17.3	17.0	16.7	17.4	17.1	16.9
125	TC	155	137	120	163	144	129	168	148	138
	SHC	35	64	93	47	84	120	59	103	138
	kW	19.0	18.6	18.3	19.2	18.8	18.5	19.3	18.9	18.7

LEGEND AND NOTES

- kW --- Compressor Power Input
- SHC --- Sensible Heat Capacity (1000 Btuh) Gross
- TC --- Total Capacity (1000 Btuh) Gross

48LC*A20 REHEAT MODE #2 CAPACITIES (MBTUH), STANDARD UNITS

Reheat-2 (Hot Gas Reheat Mode)		AIR ENTERING EVAPORATOR - SCFM/BF (80db)								
		5250			7000			8750		
Outdoor Air Temp ° F		Air Entering Evaporator -- Ewb (F)								
		62.5	64	65.3	62.5	64	65.3	62.5	64	65.3
80	TC	77	80	82	80	83	85	81	84	87
	SHC	18	8	-1	33	20	9	49	34	20
	kW	11.8	12.0	12.2	12.0	12.1	12.3	12.1	12.2	12.4
75	TC	82	86	88	86	89	91	88	91	93
	SHC	24	14	5	39	26	15	55	40	26
	kW	11.3	11.5	11.6	11.5	11.6	11.8	11.6	11.7	11.9
70	TC	88	91	94	92	95	98	94	97	100
	SHC	29	19	10	45	32	21	61	46	32
	kW	10.8	11.0	11.1	11.0	11.1	11.3	11.1	11.2	11.4
60	TC	99	103	106	103	107	110	106	109	112
	SHC	40	30	22	56	43	33	72	58	45
	kW	10.0	10.1	10.2	10.1	10.3	10.4	10.2	10.4	10.5
50	TC	111	114	118	115	119	122	118	122	125
	SHC	51	42	33	68	55	45	84	70	57
	kW	9.2	9.3	9.5	9.3	9.5	9.6	9.5	9.6	9.7
40	TC	122	126	129	127	131	134	130	134	137
	SHC	63	53	45	80	68	57	97	83	70
	kW	8.5	8.7	8.8	8.7	8.8	9.0	8.8	9.0	9.1

LEGEND AND NOTES

- kW --- Compressor Power Input
- SHC --- Sensible Heat Capacity (1000 Btuh) Gross
- TC --- Total Capacity (1000 Btuh) Gross

Table 24 – COOLING CAPACITIES - FIRST STAGE, PART LOAD

20 TONS

24 SIZE			AMBIENT TEMPERATURE																
			85°F			95°F			105°F			115°F			125°F				
			EAT (db)			EAT (db)			EAT (db)			EAT (db)			EAT (db)				
			75	80	85	75	80	85	75	80	85	75	80	85	75	80	85		
3150 Cfm	EAT (wb)	58	TC	87.9	87.9	101.5	79.4	79.4	92.4	70.7	70.7	83.3	61.7	61.7	73.7	52.6	52.6	64.0	
			SHC	74.4	87.9	101.5	66.3	79.4	92.4	58.1	70.7	83.3	49.7	61.7	73.7	41.1	52.6	64.0	
		62	TC	91.3	91.3	101.0	81.4	81.4	93.7	71.6	71.6	86.2	61.9	61.9	77.9	52.7	52.7	67.9	
			SHC	68.1	84.5	101.0	60.8	77.2	93.7	53.5	69.8	86.2	45.8	61.9	77.9	37.4	52.7	67.9	
		67	TC	104.6	104.6	104.6	94.1	94.1	94.1	83.5	83.5	83.5	72.6	72.6	72.6	61.4	61.4	61.4	
			SHC	54.7	71.4	87.9	47.5	64.2	80.7	40.3	56.9	73.5	33.0	49.6	66.2	25.5	42.2	58.8	
	72	TC	119.6	119.6	119.6	108.6	108.6	108.6	97.4	97.4	97.4	86.0	86.0	86.0	74.1	74.1	74.1		
		SHC	41.1	57.8	74.6	33.9	50.6	67.4	26.7	43.4	60.2	19.4	36.2	52.8	12.1	28.8	45.4		
	76	TC	-	132.6	132.6	-	121.1	121.1	-	109.4	109.4	-	97.4	97.4	-	85.0	85.0		
		SHC	-	46.8	63.7	-	39.6	56.6	-	32.4	49.3	-	25.2	42.0	-	17.7	34.6		
	3650 Cfm	EAT (wb)	58	TC	94.8	94.8	109.0	85.7	85.7	99.5	76.5	76.5	89.7	67.2	67.2	79.8	57.5	57.5	69.4
				SHC	80.4	94.8	109.0	72.0	85.7	99.5	63.4	76.5	89.7	54.7	67.2	79.8	45.6	57.5	69.4
62			TC	95.6	95.6	112.7	85.9	85.9	104.2	76.7	76.7	94.3	67.4	67.4	84.1	57.6	57.6	73.5	
			SHC	75.4	94.1	112.7	67.6	85.9	104.2	59.2	76.7	94.3	50.6	67.4	84.1	41.7	57.6	73.5	
67			TC	108.2	108.2	108.2	97.4	97.4	97.4	86.5	86.5	86.5	75.3	75.3	75.8	63.8	63.8	68.2	
			SHC	59.8	78.9	98.0	52.5	71.6	90.7	45.0	64.2	83.3	37.6	56.6	75.8	30.0	49.1	68.2	
72		TC	123.4	123.4	123.4	112.0	112.0	112.0	100.5	100.5	100.5	88.6	88.6	88.6	76.4	76.4	76.4		
		SHC	43.7	63.0	82.2	36.4	55.6	74.9	29.1	48.3	67.5	21.5	40.8	60.0	14.0	33.2	52.5		
76		TC	-	136.5	136.5	-	124.7	124.7	-	112.6	112.6	-	100.2	100.2	-	87.5	87.5		
		SHC	-	49.9	69.4	-	42.6	62.1	-	35.3	54.7	-	27.9	47.2	-	20.3	39.7		
4200 Cfm		EAT (wb)	58	TC	101.0	101.0	115.9	91.6	91.6	105.9	82.0	82.0	95.7	72.2	72.2	85.3	62.1	62.1	74.5
				SHC	86.1	101.0	115.9	77.2	91.6	105.9	68.3	82.0	95.7	59.2	72.2	85.3	49.7	62.1	74.5
	62		TC	101.2	101.2	121.1	91.7	91.7	110.9	82.2	82.2	100.5	72.3	72.3	89.8	62.2	62.2	78.8	
			SHC	81.2	101.2	121.1	72.5	91.7	110.9	63.9	82.2	100.5	54.9	72.3	89.8	45.6	62.2	78.8	
	67		TC	111.4	111.4	111.4	100.2	100.2	101.0	89.0	89.0	93.4	77.6	77.6	85.8	65.8	65.8	77.9	
			SHC	64.9	86.8	108.5	57.5	79.3	101.0	50.0	71.8	93.4	42.4	64.2	85.8	34.7	56.4	77.9	
	72	TC	126.8	126.8	126.8	115.0	115.0	115.0	103.1	103.1	103.1	90.9	90.9	90.9	78.3	78.3	78.3		
		SHC	46.2	68.2	90.1	38.8	60.7	82.6	31.3	53.2	75.2	23.8	45.6	67.6	16.1	38.0	59.9		
	76	TC	-	139.9	139.9	-	127.7	127.7	-	115.2	115.2	-	102.6	102.6	-	89.4	89.4		
		SHC	-	53.0	75.2	-	45.6	67.8	-	38.1	60.3	-	30.6	52.7	-	22.9	44.9		
	4700 Cfm	EAT (wb)	58	TC	105.9	105.9	121.3	96.1	96.1	110.9	86.2	86.2	100.3	76.1	76.1	89.5	65.6	65.6	78.3
				SHC	90.5	105.9	121.3	81.3	96.1	110.9	72.1	86.2	100.3	62.6	76.1	89.5	52.8	65.6	78.3
62			TC	106.0	106.0	126.7	96.2	96.2	116.0	86.4	86.4	105.2	76.1	76.1	94.2	65.7	65.7	82.8	
			SHC	85.4	106.0	126.7	76.4	96.2	116.0	67.5	86.4	105.2	58.2	76.1	94.2	48.7	65.7	82.8	
67			TC	113.8	113.8	117.7	102.5	102.5	110.0	91.1	91.1	102.3	79.4	79.4	94.4	67.5	67.5	86.3	
			SHC	69.4	93.6	117.7	61.8	85.9	110.0	54.2	78.3	102.3	46.5	70.5	94.4	38.7	62.5	86.3	
72		TC	129.0	129.0	129.0	117.0	117.0	117.0	104.9	104.9	104.9	92.4	92.4	92.4	79.7	79.7	79.7		
		SHC	48.4	72.6	97.0	40.9	65.1	89.4	33.2	57.5	81.8	25.6	49.8	74.1	17.8	42.1	66.4		
76		TC	-	142.4	142.4	-	129.9	129.9	-	117.2	117.2	-	104.2	104.2	-	90.9	90.9		
		SHC	-	55.6	80.1	-	48.1	72.6	-	40.6	65.0	-	32.9	57.3	-	25.2	49.5		
5250 Cfm		EAT (wb)	58	TC	110.5	110.5	126.3	100.3	100.3	115.5	90.2	90.2	104.7	79.7	79.7	93.5	68.9	68.9	82.0
				SHC	94.6	110.5	126.3	85.1	100.3	115.5	75.7	90.2	104.7	65.9	79.7	93.5	55.9	68.9	82.0
	62		TC	110.6	110.6	131.8	100.5	100.5	120.8	90.3	90.3	109.7	79.9	79.9	98.3	69.0	69.0	86.5	
			SHC	89.4	110.6	131.8	80.1	100.5	120.8	70.9	90.3	109.7	61.3	79.9	98.3	51.6	69.0	86.5	
	67		TC	115.9	115.9	127.3	104.5	104.5	119.4	92.9	92.9	111.4	81.2	81.2	103.2	69.7	69.7	93.6	
			SHC	74.1	100.7	127.3	66.4	92.9	119.4	58.7	85.0	111.4	50.7	76.9	103.2	42.4	68.0	93.6	
	72	TC	131.0	131.0	131.0	118.9	118.9	118.9	106.5	106.5	106.5	93.9	93.9	93.9	80.8	80.8	80.8		
		SHC	50.5	77.3	104.2	42.9	69.7	96.5	35.2	62.1	88.9	27.5	54.3	81.1	19.7	46.5	73.2		
	76	TC	-	144.4	144.4	-	131.7	131.7	-	118.9	118.9	-	105.7	105.7	-	92.1	92.1		
		SHC	-	58.2	85.3	-	50.7	77.7	-	43.0	70.1	-	35.3	62.3	-	27.5	54.5		

LEGEND:

- - Do not operate
- Cfm - Cubic feet per minute (supply air)
- EAT (db) - Entering Air Temperature (dry bulb)
- EAT (wb) - Entering Air Temperature (wet bulb)
- SHC - Sensible Heat Capacity (1000 Btuh) Gross
- TC - Total Capacity (1000 Btuh) Gross

Table 25 – COOLING CAPACITIES - SECOND STAGE, PART LOAD

20 TONS

24 SIZE			AMBIENT TEMPERATURE																
			85°F			95°F			105°F			115°F			125°F				
			EAT (db)			EAT (db)			EAT (db)			EAT (db)			EAT (db)				
			75	80	85	75	80	85	75	80	85	75	80	85	75	80	85		
3900 Cfm	EAT (wb)	58	TC	128.8	128.8	146.4	121.7	121.7	138.6	114.1	114.1	130.4	105.8	105.8	121.3	96.9	96.9	111.5	
			SHC	111.2	128.8	146.4	104.7	121.7	138.6	97.8	114.1	130.4	90.3	105.8	121.3	82.2	96.9	111.5	
		62	TC	134.0	134.0	141.8	125.6	125.6	136.5	116.5	116.5	130.7	106.8	106.8	124.5	97.0	97.0	116.6	
			SHC	101.1	121.4	141.8	95.8	116.1	136.5	90.3	110.5	130.7	84.3	104.4	124.5	77.4	97.0	116.6	
		67	TC	148.8	148.8	148.8	139.8	139.8	139.8	130.1	130.1	130.1	119.5	119.5	119.5	108.2	108.2	108.2	
			SHC	82.5	103.0	123.4	77.3	97.8	118.3	71.9	92.3	112.8	66.1	86.6	107.1	60.1	80.5	101.0	
	72	TC	165.6	165.6	165.6	156.1	156.1	156.1	145.9	145.9	145.9	134.6	134.6	134.6	122.7	122.7	122.7		
		SHC	63.5	84.1	104.7	58.4	79.0	99.6	53.0	73.6	94.2	47.4	68.0	88.5	41.4	62.0	82.6		
	76	TC	-	179.7	179.7	-	169.8	169.8	-	159.1	159.1	-	147.5	147.5	-	134.8	134.8		
		SHC	-	68.5	89.5	-	63.6	84.4	-	58.3	79.2	-	52.7	73.6	-	46.9	67.7		
	4500 Cfm	EAT (wb)	58	TC	136.4	136.4	154.8	129.0	129.0	146.7	120.9	120.9	138.0	112.1	112.1	128.4	102.8	102.8	118.1
				SHC	118.0	136.4	154.8	111.2	129.0	146.7	103.8	120.9	138.0	95.9	112.1	128.4	87.5	102.8	118.1
62			TC	138.6	138.6	155.8	130.2	130.2	150.1	121.0	121.0	143.8	112.3	112.3	134.1	103.0	103.0	123.4	
			SHC	109.5	132.7	155.8	104.0	127.0	150.1	98.2	121.0	143.8	90.7	112.3	134.1	82.5	103.0	123.4	
67			TC	153.0	153.0	153.0	143.7	143.7	143.7	133.7	133.7	133.7	122.9	122.9	122.9	111.2	111.2	112.1	
			SHC	88.0	111.4	134.9	82.8	106.3	129.7	77.3	100.7	124.1	71.5	94.9	118.3	65.4	88.7	112.1	
72		TC	169.9	169.9	169.9	160.2	160.2	160.2	149.5	149.5	149.5	138.0	138.0	138.0	125.5	125.5	125.5		
		SHC	66.1	89.7	113.3	60.9	84.5	108.1	55.5	79.1	102.6	49.8	73.3	96.8	43.8	67.4	90.9		
76		TC	-	184.1	184.1	-	173.9	173.9	-	162.8	162.8	-	150.8	150.8	-	137.9	137.9		
		SHC	-	71.9	95.7	-	66.7	90.6	-	61.3	85.2	-	55.8	79.6	-	49.8	73.6		
5150 Cfm		EAT (wb)	58	TC	143.3	143.3	162.5	135.5	135.5	154.1	127.0	127.0	144.8	118.0	118.0	134.8	108.1	108.1	124.0
				SHC	124.0	143.3	162.5	117.0	135.5	154.1	109.3	127.0	144.8	101.0	118.0	134.8	92.1	108.1	124.0
	62		TC	143.4	143.4	169.2	135.7	135.7	160.5	127.2	127.2	151.0	118.1	118.1	140.7	108.2	108.2	129.5	
			SHC	117.7	143.4	169.2	110.9	135.7	160.5	103.4	127.2	151.0	95.6	118.1	140.7	87.0	108.2	129.5	
	67		TC	156.6	156.6	156.6	147.0	147.0	147.0	136.8	136.8	136.8	125.7	125.7	129.9	113.7	113.7	123.5	
			SHC	93.8	120.3	146.8	88.4	115.0	141.5	82.9	109.4	135.9	77.0	103.4	129.9	70.8	97.2	123.5	
	72	TC	173.6	173.6	173.6	163.4	163.4	163.4	152.5	152.5	152.5	140.6	140.6	140.6	127.8	127.8	127.8		
		SHC	68.6	95.4	122.1	63.5	90.1	116.8	58.0	84.6	111.3	52.2	78.8	105.5	46.1	72.7	99.4		
	76	TC	-	187.8	187.8	-	177.3	177.3	-	165.9	165.9	-	153.7	153.7	-	140.3	140.3		
		SHC	-	75.0	102.1	-	69.8	96.8	-	64.4	91.4	-	58.8	85.7	-	52.7	79.7		
	5800 Cfm	EAT (wb)	58	TC	149.2	149.2	169.1	141.1	141.1	160.2	132.3	132.3	150.6	122.8	122.8	140.2	112.5	112.5	129.0
				SHC	129.2	149.2	169.1	121.9	141.1	160.2	113.9	132.3	150.6	105.3	122.8	140.2	96.1	112.5	129.0
62			TC	149.3	149.3	175.9	141.2	141.2	166.8	132.4	132.4	157.0	122.9	122.9	146.3	112.7	112.7	134.6	
			SHC	122.7	149.3	175.9	115.5	141.2	166.8	107.9	132.4	157.0	99.6	122.9	146.3	90.7	112.7	134.6	
67			TC	159.4	159.4	159.4	149.8	149.8	152.9	139.2	139.2	147.1	127.9	127.9	141.0	115.8	115.8	134.5	
			SHC	99.2	128.7	158.2	93.8	123.3	152.9	88.1	117.6	147.1	82.2	111.6	141.0	75.9	105.2	134.5	
72		TC	176.3	176.3	176.3	165.9	165.9	165.9	154.8	154.8	154.8	142.7	142.7	142.7	129.8	129.8	129.8		
		SHC	71.0	100.7	130.5	65.7	95.5	125.2	60.3	89.9	119.6	54.4	84.0	113.7	48.3	77.9	107.5		
76		TC	-	190.6	190.6	-	179.9	179.9	-	168.3	168.3	-	155.8	155.8	-	142.3	142.3		
		SHC	-	77.9	108.0	-	72.7	102.8	-	67.3	97.3	-	61.6	91.6	-	55.6	85.4		
6450 Cfm		EAT (wb)	58	TC	154.1	154.1	174.6	145.8	145.8	165.6	136.7	136.7	155.6	126.9	126.9	144.9	116.3	116.3	133.2
				SHC	133.7	154.1	174.6	126.1	145.8	165.6	117.9	136.7	155.6	109.0	126.9	144.9	99.5	116.3	133.2
	62		TC	154.3	154.3	181.6	146.0	146.0	172.3	136.9	136.9	162.1	127.0	127.0	151.0	116.5	116.5	139.0	
			SHC	126.9	154.3	181.6	119.5	146.0	172.3	111.6	136.9	162.1	103.2	127.0	151.0	93.9	116.5	139.0	
	67		TC	161.9	161.9	169.3	152.0	152.0	163.7	141.5	141.5	157.9	130.1	130.1	151.4	117.9	117.9	144.4	
			SHC	104.3	136.8	169.3	98.9	131.3	163.7	93.2	125.5	157.9	87.2	119.3	151.4	80.6	112.5	144.4	
	72	TC	178.5	178.5	178.5	168.0	168.0	168.0	156.7	156.7	156.7	144.4	144.4	144.4	131.1	131.1	131.1		
		SHC	73.2	105.9	138.5	67.9	100.5	133.2	62.3	95.0	127.6	56.5	89.1	121.7	50.3	82.9	115.4		
	76	TC	-	192.9	192.9	-	182.0	182.0	-	170.2	170.2	-	157.5	157.5	-	143.8	143.8		
		SHC	-	80.7	113.7	-	75.5	108.5	-	70.0	103.0	-	64.3	97.1	-	58.2	91.1		

LEGEND:

- - Do not operate
- Cfm - Cubic feet per minute (supply air)
- EAT (db) - Entering Air Temperature (dry bulb)
- EAT (wb) - Entering Air Temperature (wet bulb)
- SHC - Sensible Heat Capacity (1000 Btuh) Gross
- TC - Total Capacity (1000 Btuh) Gross

Table 26 – COOLING CAPACITIES - THIRD STAGE, FULL LOAD

20 TONS

24 SIZE			AMBIENT TEMPERATURE																
			85°F			95°F			105°F			115°F			125°F				
			EAT (db)			EAT (db)			EAT (db)			EAT (db)			EAT (db)				
			75	80	85	75	80	85	75	80	85	75	80	85	75	80	85		
6000 Cfm	EAT (wb)	58	TC	217.4	217.4	245.6	208.3	208.3	235.6	198.5	198.5	224.7	188.0	188.0	213.0	176.6	176.6	200.3	
			SHC	189.2	217.4	245.6	181.1	208.3	235.6	172.4	198.5	224.7	163.0	188.0	213.0	152.9	176.6	200.3	
		62	TC	227.3	227.3	230.2	216.2	216.2	224.2	204.4	204.4	217.6	191.7	191.7	210.8	178.2	178.2	203.0	
			SHC	169.0	199.6	230.2	162.9	193.5	224.2	156.6	187.1	217.6	149.9	180.4	210.8	142.6	172.9	203.0	
		67	TC	248.8	248.8	248.8	236.8	236.8	236.8	224.1	224.1	224.1	210.2	210.2	210.2	195.4	195.4	195.4	
			SHC	139.0	169.8	200.7	133.2	164.0	194.7	127.0	157.8	188.6	120.5	151.2	182.0	113.7	144.4	175.1	
	72	TC	273.6	273.6	273.6	260.9	260.9	260.9	247.1	247.1	247.1	232.2	232.2	232.2	216.4	216.4	216.4		
		SHC	108.9	140.0	171.0	103.3	134.3	165.3	97.1	128.1	159.1	90.8	121.7	152.7	84.0	115.0	145.9		
	76	TC	-	294.8	294.8	-	281.4	281.4	-	266.8	266.8	-	251.1	251.1	-	234.3	234.3		
		SHC	-	115.5	147.7	-	110.0	142.2	-	103.9	135.9	-	97.7	129.4	-	91.1	122.7		
	7000 Cfm	EAT (wb)	58	TC	229.4	229.4	259.1	219.7	219.7	248.3	209.2	209.2	236.7	198.0	198.0	224.2	185.9	185.9	210.7
				SHC	199.7	229.4	259.1	191.1	219.7	248.3	181.7	209.2	236.7	171.8	198.0	224.2	161.1	185.9	210.7
62			TC	234.9	234.9	252.1	223.4	223.4	245.7	211.3	211.3	238.8	199.3	199.3	229.8	186.2	186.2	219.4	
			SHC	182.0	217.1	252.1	175.8	210.8	245.7	169.3	204.0	238.8	161.7	195.7	229.8	153.1	186.2	219.4	
67			TC	256.2	256.2	256.2	243.2	243.2	243.2	229.8	229.8	229.8	215.6	215.6	215.6	200.3	200.3	200.3	
			SHC	147.7	183.1	218.5	141.6	177.0	212.3	135.3	170.6	206.0	128.7	164.1	199.4	121.8	157.1	192.4	
72		TC	281.0	281.0	281.0	267.6	267.6	267.6	253.2	253.2	253.2	237.7	237.7	237.7	221.3	221.3	221.3		
		SHC	112.8	148.5	184.2	107.1	142.6	178.2	100.8	136.4	172.0	94.4	129.9	165.4	87.6	123.0	158.5		
76		TC	-	302.4	302.4	-	288.3	288.3	-	273.1	273.1	-	256.7	256.7	-	239.4	239.4		
		SHC	-	120.4	157.2	-	114.7	151.3	-	108.6	145.1	-	102.2	138.5	-	95.5	131.6		
8000 Cfm		EAT (wb)	58	TC	239.2	239.2	270.1	228.9	228.9	258.8	217.9	217.9	246.5	206.2	206.2	233.4	193.5	193.5	219.3
				SHC	208.3	239.2	270.1	199.2	228.9	258.8	189.4	217.9	246.5	179.0	206.2	233.4	167.8	193.5	219.3
	62		TC	241.3	241.3	272.3	229.9	229.9	265.0	218.1	218.1	256.1	206.6	206.6	242.9	193.7	193.7	228.1	
			SHC	194.0	233.1	272.3	187.4	226.2	265.0	180.0	218.1	256.1	170.1	206.5	242.9	159.3	193.7	228.1	
	67		TC	261.6	261.6	261.6	248.2	248.2	248.2	234.5	234.5	234.5	219.8	219.8	219.8	204.0	204.0	208.7	
			SHC	155.7	195.6	235.5	149.5	189.3	229.2	143.1	183.0	222.8	136.5	176.4	216.2	129.4	169.1	208.7	
	72	TC	286.7	286.7	286.7	272.9	272.9	272.9	258.0	258.0	258.0	242.1	242.1	242.1	225.0	225.0	225.0		
		SHC	116.4	156.5	196.7	110.5	150.5	190.7	104.2	144.3	184.4	97.7	137.7	177.6	90.8	130.7	170.6		
	76	TC	-	308.3	308.3	-	293.8	293.8	-	278.1	278.1	-	261.1	261.1	-	243.3	243.3		
		SHC	-	124.9	166.0	-	119.0	160.1	-	112.9	153.8	-	106.4	147.1	-	99.6	140.2		
	9000 Cfm	EAT (wb)	58	TC	247.4	247.4	279.2	236.7	236.7	267.4	225.3	225.3	254.8	213.0	213.0	241.1	199.9	199.9	226.4
				SHC	215.4	247.4	279.2	206.0	236.7	267.4	195.9	225.3	254.8	185.1	213.0	241.1	173.4	199.9	226.4
62			TC	247.7	247.7	290.4	236.9	236.9	278.0	225.5	225.5	264.8	213.2	213.2	250.7	200.1	200.1	235.5	
			SHC	205.0	247.7	290.4	195.9	236.9	278.0	186.2	225.5	264.8	175.8	213.2	250.7	164.7	200.1	235.5	
67			TC	266.1	266.1	266.1	252.2	252.2	252.2	238.3	238.3	239.0	223.3	223.3	232.0	207.2	207.2	224.3	
			SHC	163.4	207.6	251.8	157.1	201.2	245.4	150.6	194.8	239.0	143.9	187.9	232.0	136.7	180.5	224.3	
72		TC	291.1	291.1	291.1	277.0	277.0	277.0	261.8	261.8	261.8	245.4	245.4	245.4	228.1	228.1	228.1		
		SHC	119.6	164.1	208.7	113.7	158.1	202.6	107.3	151.8	196.2	100.7	145.1	189.3	93.8	138.1	182.3		
76		TC	-	313.0	313.0	-	298.1	298.1	-	281.9	281.9	-	264.6	264.6	-	246.3	246.3		
		SHC	-	129.0	174.4	-	123.1	168.5	-	116.9	162.1	-	110.4	155.4	-	103.5	148.4		
10000 Cfm		EAT (wb)	58	TC	254.8	254.8	287.6	243.4	243.4	275.0	231.6	231.6	261.8	218.8	218.8	247.6	205.1	205.1	232.2
				SHC	222.0	254.8	287.6	211.9	243.4	275.0	201.4	231.6	261.8	190.1	218.8	247.6	177.9	205.1	232.2
	62		TC	255.1	255.1	298.9	243.6	243.6	285.8	231.8	231.8	272.1	219.0	219.0	257.4	205.2	205.2	241.5	
			SHC	211.2	255.1	298.9	201.4	243.6	285.8	191.5	231.8	272.1	180.7	219.0	257.4	169.1	205.2	241.5	
	67		TC	269.3	269.3	269.3	255.9	255.9	261.1	241.5	241.5	254.3	226.2	226.2	247.0	210.1	210.1	239.0	
			SHC	170.4	218.9	267.3	164.3	212.7	261.1	157.8	206.0	254.3	150.8	198.9	247.0	143.4	191.2	239.0	
	72	TC	294.7	294.7	294.7	280.4	280.4	280.4	264.8	264.8	264.8	248.0	248.0	248.0	230.4	230.4	230.4		
		SHC	122.7	171.4	220.2	116.7	165.4	214.0	110.4	158.9	207.6	103.6	152.2	200.8	96.7	145.1	193.5		
	76	TC	-	316.8	316.8	-	301.5	301.5	-	285.1	285.1	-	267.4	267.4	-	248.7	248.7		
		SHC	-	133.0	182.6	-	127.0	176.6	-	120.8	170.1	-	114.2	163.4	-	107.3	156.3		

LEGEND:

- - Do not operate
- Cfm - Cubic feet per minute (supply air)
- EAT (db) - Entering Air Temperature (dry bulb)
- EAT (wb) - Entering Air Temperature (wet bulb)
- SHC - Sensible Heat Capacity (1000 Btuh) Gross
- TC - Total Capacity (1000 Btuh) Gross

48LC*A24 REHEAT MODE #1 CAPACITIES (MBTUH), STANDARD UNITS

Reheat-1 (Subcooler Mode)		AIR ENTERING EVAPORATOR - SCFM/BF (80db)								
		6000			8000			10000		
Outdoor Air Temp ° F		Air Entering Evaporator -- Ewb (F)								
		72	67	62	72	67	62	72	67	62
75	TC	274	246	221	292	263	238	281	273	250
	SHC	120	148	176	140	176	213	136	202	244
	kW	13.5	13.2	12.9	13.7	13.4	13.1	13.4	13.5	13.3
85	TC	261	233	208	277	249	225	287	258	237
	SHC	107	136	164	126	163	201	142	188	231
	kW	14.9	14.6	14.3	15.1	14.8	14.5	15.3	14.9	14.7
95	TC	245	219	196	261	232	211	270	243	222
	SHC	93	123	153	111	148	188	127	174	217
	kW	16.5	16.2	15.8	16.8	16.3	16.1	16.9	16.5	16.2
105	TC	230	205	182	244	218	196	253	226	209
	SHC	80	110	141	96	135	175	111	159	197
	kW	18.4	18.0	17.7	18.6	18.2	17.9	18.7	18.3	18.1
115	TC	213	189	168	226	201	181	234	209	191
	SHC	65	97	128	80	121	161	95	143	187
	kW	20.4	20.1	19.7	20.6	20.2	19.9	20.8	20.4	20.1
125	TC	196	173	153	207	183	164	214	190	173
	SHC	50	83	115	64	105	146	77	127	173
	kW	22.7	22.4	22.0	22.9	22.5	22.2	23.0	22.6	22.4

LEGEND AND NOTES

- kW --- Compressor Power Input
- SHC --- Sensible Heat Capacity (1000 Btuh) Gross
- TC --- Total Capacity (1000 Btuh) Gross

48LC*A24 REHEAT MODE #2 CAPACITIES (MBTUH), STANDARD UNITS

Reheat-2 (Hot Gas Reheat Mode)		AIR ENTERING EVAPORATOR - SCFM/BF (80db)								
		6000			8000			10000		
Outdoor Air Temp ° F		Air Entering Evaporator -- Ewb (F)								
		62.5	64	65.3	62.5	64	65.3	62.5	64	65.3
80	TC	89	93	96	92	96	99	94	98	101
	SHC	17	5	-5	32	17	5	48	31	16
	kW	19.6	19.9	20.2	19.9	20.2	20.4	20.0	20.3	20.6
75	TC	96	100	103	100	103	107	102	105	109
	SHC	24	12	2	39	24	12	55	38	23
	kW	18.7	19.0	19.3	19.0	19.3	19.5	19.2	19.5	19.7
70	TC	103	107	110	107	111	114	109	113	116
	SHC	30	18	8	46	31	19	62	45	30
	kW	17.9	18.2	18.4	18.2	18.5	18.7	18.4	18.6	18.9
60	TC	117	121	124	121	125	129	124	128	132
	SHC	43	32	22	59	45	33	76	59	45
	kW	16.4	16.7	16.9	16.7	16.9	17.2	16.9	17.1	17.4
50	TC	131	135	139	136	140	144	139	143	147
	SHC	56	45	35	73	59	47	91	74	59
	kW	15.1	15.3	15.6	15.4	15.6	15.9	15.6	15.8	16.0
40	TC	145	149	153	150	155	159	154	158	162
	SHC	70	59	49	87	74	62	105	89	75
	kW	14.0	14.2	14.4	14.3	14.5	14.7	14.4	14.7	14.9

LEGEND AND NOTES

- kW --- Compressor Power Input
- SHC --- Sensible Heat Capacity (1000 Btuh) Gross
- TC --- Total Capacity (1000 Btuh) Gross

Table 28 – COOLING CAPACITIES - FIRST STAGE, PART LOAD

23 TONS

26 SIZE			AMBIENT TEMPERATURE																
			85°F			95°F			105°F			115°F			125°F				
			EAT (db)			EAT (db)			EAT (db)			EAT (db)			EAT (db)				
			75	80	85	75	80	85	75	80	85	75	80	85	75	80	85		
4050 Cfm	EAT (wb)	58	TC	125.3	125.3	141.0	122.3	122.3	137.4	118.9	118.9	133.4	115.1	115.1	129.0	110.8	110.8	123.9	
			SHC	109.6	125.3	141.0	107.2	122.3	137.4	104.3	118.9	133.4	101.1	115.1	129.0	97.5	110.8	123.9	
		62	TC	126.7	126.7	142.1	122.9	122.9	140.4	119.0	119.0	138.5	115.1	115.1	133.8	110.9	110.9	128.5	
			SHC	102.4	122.3	142.1	101.1	120.7	140.4	99.5	119.0	138.5	96.5	115.1	133.8	93.2	110.9	128.5	
		67	TC	137.1	137.1	137.1	132.6	132.6	132.6	127.7	127.7	127.7	122.4	122.4	122.4	116.5	116.5	117.5	
			SHC	82.5	102.7	122.9	81.4	101.6	121.8	80.1	100.4	120.6	78.8	99.0	119.1	77.2	97.3	117.5	
	72	TC	149.9	149.9	149.9	144.8	144.8	144.8	139.3	139.3	139.3	133.4	133.4	133.4	126.8	126.8	126.8		
		SHC	61.8	82.2	102.5	60.8	81.1	101.4	59.7	80.0	100.2	58.3	78.6	98.8	56.7	77.0	97.2		
	76	TC	-	160.7	160.7	-	155.1	155.1	-	149.2	149.2	-	142.7	142.7	-	135.6	135.6		
		SHC	-	65.5	86.4	-	64.4	85.2	-	63.3	84.0	-	62.0	82.6	-	60.5	81.0		
	4750 Cfm	EAT (wb)	58	TC	130.8	130.8	147.2	127.4	127.4	143.2	123.7	123.7	138.9	119.5	119.5	134.1	114.9	114.9	128.6
				SHC	114.4	130.8	147.2	111.5	127.4	143.2	108.5	123.7	138.9	105.0	119.5	134.1	101.0	114.9	128.6
62			TC	130.9	130.9	152.9	127.5	127.5	148.7	123.8	123.8	144.1	119.6	119.6	139.0	114.9	114.9	133.3	
			SHC	108.9	130.9	152.9	106.4	127.5	148.7	103.4	123.8	144.1	100.2	119.6	139.0	96.5	114.9	133.3	
67			TC	139.8	139.8	139.8	135.1	135.1	135.1	130.1	130.1	131.2	124.5	124.5	129.7	118.5	118.5	127.8	
			SHC	87.4	110.6	133.8	86.2	109.4	132.6	84.9	108.1	131.2	83.5	106.6	129.7	81.8	104.8	127.8	
72		TC	152.8	152.8	152.8	147.4	147.4	147.4	141.8	141.8	141.8	135.5	135.5	135.5	128.7	128.7	128.7		
		SHC	63.8	87.1	110.4	62.7	85.9	109.2	61.4	84.7	107.9	60.1	83.3	106.5	58.5	81.6	104.8		
76		TC	-	163.7	163.7	-	158.0	158.0	-	151.7	151.7	-	144.9	144.9	-	137.5	137.5		
		SHC	-	68.1	91.8	-	67.0	90.7	-	65.7	89.4	-	64.4	87.9	-	62.8	86.2		
5400 Cfm		EAT (wb)	58	TC	135.0	135.0	152.1	131.4	131.4	147.8	127.4	127.4	143.1	122.9	122.9	138.0	118.0	118.0	132.1
				SHC	118.1	135.0	152.1	115.1	131.4	147.8	111.7	127.4	143.1	107.9	122.9	138.0	103.7	118.0	132.1
	62		TC	135.1	135.1	157.9	131.5	131.5	153.4	127.5	127.5	148.5	123.0	123.0	143.0	118.0	118.0	137.0	
			SHC	112.4	135.1	157.9	109.6	131.5	153.4	106.5	127.5	148.5	103.0	123.0	143.0	99.1	118.0	137.0	
	67		TC	141.9	141.9	143.3	137.0	137.0	142.0	131.8	131.8	140.6	126.2	126.2	138.8	120.0	120.0	136.7	
			SHC	91.7	117.5	143.3	90.4	116.2	142.0	89.1	114.9	140.6	87.7	113.2	138.8	85.8	111.2	136.7	
	72	TC	154.8	154.8	154.8	149.3	149.3	149.3	143.4	143.4	143.4	137.0	137.0	137.0	130.0	130.0	130.0		
		SHC	65.4	91.4	117.3	64.3	90.2	116.0	63.0	88.9	114.8	61.6	87.5	113.2	60.1	85.8	111.5		
	76	TC	-	165.9	165.9	-	159.9	159.9	-	153.4	153.4	-	146.4	146.4	-	138.8	138.8		
		SHC	-	70.2	96.6	-	69.1	95.4	-	67.9	94.1	-	66.4	92.5	-	64.8	90.8		
	6100 Cfm	EAT (wb)	58	TC	138.9	138.9	156.5	135.0	135.0	151.9	130.7	130.7	146.9	126.1	126.1	141.5	120.7	120.7	135.3
				SHC	121.4	138.9	156.5	118.2	135.0	151.9	114.6	130.7	146.9	110.7	126.1	141.5	106.2	120.7	135.3
62			TC	139.0	139.0	162.4	135.1	135.1	157.7	130.8	130.8	152.5	126.1	126.1	146.7	120.8	120.8	140.3	
			SHC	115.5	139.0	162.4	112.6	135.1	157.7	109.2	130.8	152.5	105.5	126.1	146.7	101.3	120.8	140.3	
67			TC	143.7	143.7	153.1	138.7	138.7	151.6	133.5	133.5	150.1	127.7	127.7	148.0	121.6	121.6	145.4	
			SHC	95.9	124.5	153.1	94.8	123.2	151.6	93.4	121.7	150.1	91.7	119.8	148.0	89.7	117.6	145.4	
72		TC	156.6	156.6	156.6	150.8	150.8	150.8	144.8	144.8	144.8	138.3	138.3	138.3	131.0	131.0	131.0		
		SHC	67.1	95.6	124.3	65.9	94.5	123.1	64.6	93.2	121.7	63.2	91.7	120.1	61.6	90.0	118.4		
76		TC	-	167.8	167.8	-	161.6	161.6	-	154.9	154.9	-	147.8	147.8	-	139.9	139.9		
		SHC	-	72.4	101.5	-	71.3	100.2	-	70.0	98.9	-	68.5	97.3	-	66.9	95.4		
6750 Cfm		EAT (wb)	58	TC	142.0	142.0	159.9	137.9	137.9	155.1	133.4	133.4	150.0	128.4	128.4	144.2	122.9	122.9	137.8
				SHC	124.0	142.0	159.9	120.6	137.9	155.1	116.9	133.4	150.0	112.7	128.4	144.2	108.0	122.9	137.8
	62		TC	142.1	142.1	166.0	138.0	138.0	161.0	133.5	133.5	155.6	128.5	128.5	149.6	122.9	122.9	142.8	
			SHC	118.1	142.1	166.0	114.9	138.0	161.0	111.3	133.5	155.6	107.4	128.5	149.6	103.1	122.9	142.8	
	67		TC	145.2	145.2	161.6	140.2	140.2	160.0	134.8	134.8	158.0	129.2	129.2	155.5	123.1	123.1	151.9	
			SHC	99.8	130.7	161.6	98.5	129.3	160.0	97.0	127.5	158.0	95.2	125.4	155.5	92.7	122.4	151.9	
	72	TC	157.9	157.9	157.9	152.1	152.1	152.1	145.9	145.9	145.9	139.1	139.1	139.1	131.8	131.8	131.8		
		SHC	68.5	99.6	130.7	67.4	98.4	129.4	66.1	97.0	127.9	64.6	95.5	126.4	63.0	93.8	124.5		
	76	TC	-	169.2	169.2	-	162.7	162.7	-	156.0	156.0	-	148.7	148.7	-	140.7	140.7		
		SHC	-	74.4	105.9	-	73.2	104.6	-	71.9	103.2	-	70.4	101.5	-	68.7	99.5		

LEGEND:

- - Do not operate
- Cfm - Cubic feet per minute (supply air)
- EAT (db) - Entering Air Temperature (dry bulb)
- EAT (wb) - Entering Air Temperature (wet bulb)
- SHC - Sensible Heat Capacity (1000 Btuh) Gross
- TC - Total Capacity (1000 Btuh) Gross

Table 29 – COOLING CAPACITIES - SECOND STAGE, PART LOAD

23 TONS

26 SIZE			AMBIENT TEMPERATURE																
			85°F			95°F			105°F			115°F			125°F				
			EAT (db)			EAT (db)			EAT (db)			EAT (db)			EAT (db)				
			75	80	85	75	80	85	75	80	85	75	80	85	75	80	85		
4850 Cfm	EAT (wb)	58	TC	157.5	157.5	178.5	149.6	149.6	169.9	141.2	141.2	160.8	132.3	132.3	151.0	122.7	122.7	140.4	
			SHC	136.4	157.5	178.5	129.3	149.6	169.9	121.7	141.2	160.8	113.7	132.3	151.0	105.0	122.7	140.4	
		62	TC	164.0	164.0	170.5	154.5	154.5	164.7	144.7	144.7	158.5	134.4	134.4	151.9	123.3	123.3	144.5	
			SHC	123.0	146.7	170.5	117.3	141.0	164.7	111.3	134.9	158.5	105.0	128.4	151.9	98.3	121.4	144.5	
		67	TC	181.1	181.1	181.1	170.7	170.7	170.7	159.8	159.8	159.8	148.2	148.2	148.2	135.8	135.8	135.8	
			SHC	100.8	124.6	148.5	95.1	119.0	142.8	89.2	113.1	136.9	83.1	107.0	130.7	76.7	100.5	124.3	
	72	TC	200.2	200.2	200.2	189.0	189.0	189.0	177.2	177.2	177.2	164.8	164.8	164.8	151.4	151.4	151.4		
		SHC	78.1	102.2	126.3	72.4	96.5	120.5	66.5	90.6	114.7	60.5	84.5	108.5	54.2	78.1	102.1		
	76	TC	-	216.2	216.2	-	204.3	204.3	-	191.9	191.9	-	178.6	178.6	-	164.6	164.6		
		SHC	-	83.8	109.0	-	78.1	103.2	-	72.3	97.2	-	66.2	91.0	-	60.0	84.5		
	5700 Cfm	EAT (wb)	58	TC	167.0	167.0	189.2	158.5	158.5	179.9	149.7	149.7	170.1	140.1	140.1	159.6	129.8	129.8	148.3
				SHC	144.8	167.0	189.2	137.2	158.5	179.9	129.1	149.7	170.1	120.5	140.1	159.6	111.2	129.8	148.3
62			TC	170.0	170.0	187.4	160.4	160.4	181.1	150.4	150.4	174.2	140.2	140.2	166.3	130.0	130.0	154.6	
			SHC	133.3	160.3	187.4	127.2	154.1	181.1	121.0	147.6	174.2	114.1	140.2	166.3	105.2	130.0	154.6	
67			TC	186.5	186.5	186.5	175.4	175.4	175.4	164.1	164.1	164.1	152.1	152.1	152.1	139.2	139.2	139.2	
			SHC	107.5	134.9	162.3	101.7	129.0	156.4	95.6	123.0	150.4	89.5	116.8	144.2	83.0	110.3	137.6	
72		TC	205.5	205.5	205.5	193.9	193.9	193.9	181.6	181.6	181.6	168.7	168.7	168.7	154.9	154.9	154.9		
		SHC	81.2	108.8	136.5	75.5	103.1	130.7	69.5	97.0	124.6	63.4	90.9	118.4	56.9	84.4	111.8		
76		TC	-	221.7	221.7	-	209.3	209.3	-	196.5	196.5	-	182.6	182.6	-	168.1	168.1		
		SHC	-	87.7	116.2	-	81.9	110.3	-	76.0	104.2	-	69.8	98.0	-	63.5	91.5		
6500 Cfm		EAT (wb)	58	TC	174.4	174.4	197.4	165.5	165.5	187.7	156.0	156.0	177.3	146.0	146.0	166.2	135.1	135.1	154.3
				SHC	151.3	174.4	197.4	143.3	165.5	187.7	134.7	156.0	177.3	125.7	146.0	166.2	116.0	135.1	154.3
	62		TC	175.2	175.2	201.4	165.5	165.5	195.1	156.2	156.2	184.6	146.1	146.1	173.2	135.3	135.3	160.9	
			SHC	142.0	171.7	201.4	135.9	165.5	195.1	127.8	156.2	184.6	119.0	146.1	173.2	109.7	135.3	160.9	
	67		TC	190.1	190.1	190.1	178.8	178.8	178.8	167.2	167.2	167.2	154.9	154.9	156.0	141.9	141.9	149.4	
			SHC	113.3	143.9	174.4	107.3	137.9	168.5	101.3	131.8	162.4	95.1	125.6	156.0	88.5	119.0	149.4	
	72	TC	209.4	209.4	209.4	197.4	197.4	197.4	184.9	184.9	184.9	171.5	171.5	171.5	157.4	157.4	157.4		
		SHC	83.9	114.7	145.4	78.0	108.7	139.4	72.0	102.7	133.4	65.8	96.4	127.0	59.3	89.9	120.4		
	76	TC	-	225.7	225.7	-	213.0	213.0	-	199.8	199.8	-	185.4	185.4	-	170.6	170.6		
		SHC	-	90.9	122.6	-	85.1	116.6	-	79.1	110.6	-	72.8	104.1	-	66.4	97.6		
	7300 Cfm	EAT (wb)	58	TC	180.5	180.5	204.3	171.0	171.0	193.8	161.2	161.2	183.0	150.7	150.7	171.6	139.5	139.5	159.2
				SHC	156.8	180.5	204.3	148.2	171.0	193.8	139.3	161.2	183.0	130.0	150.7	171.6	119.9	139.5	159.2
62			TC	180.7	180.7	212.4	171.2	171.2	201.6	161.4	161.4	190.5	150.9	150.9	178.7	139.6	139.6	165.8	
			SHC	148.9	180.7	212.4	140.7	171.2	201.6	132.2	161.4	190.5	123.1	150.9	178.7	113.4	139.6	165.8	
67			TC	193.2	193.2	193.2	181.7	181.7	181.7	170.0	170.0	173.7	157.4	157.4	167.4	144.1	144.1	160.4	
			SHC	119.0	152.6	186.2	112.9	146.5	180.2	106.8	140.2	173.7	100.4	134.0	167.4	93.7	127.0	160.4	
72		TC	212.6	212.6	212.6	200.3	200.3	200.3	187.4	187.4	187.4	173.8	173.8	173.8	159.4	159.4	159.4		
		SHC	86.3	120.2	154.1	80.4	114.3	148.0	74.3	108.1	141.9	68.1	101.8	135.4	61.5	95.2	128.8		
76		TC	-	228.9	228.9	-	216.1	216.1	-	202.5	202.5	-	187.8	187.8	-	172.7	172.7		
		SHC	-	94.0	128.7	-	88.1	122.8	-	82.1	116.6	-	75.8	110.1	-	69.3	103.5		
8100 Cfm		EAT (wb)	58	TC	185.6	185.6	209.9	175.8	175.8	199.2	165.7	165.7	188.0	154.8	154.8	176.1	143.2	143.2	163.3
				SHC	161.3	185.6	209.9	152.4	175.8	199.2	143.3	165.7	188.0	133.6	154.8	176.1	123.1	143.2	163.3
	62		TC	185.8	185.8	218.3	176.0	176.0	207.2	165.8	165.8	195.7	154.9	154.9	183.4	143.3	143.3	170.1	
			SHC	153.3	185.8	218.3	144.7	176.0	207.2	135.9	165.8	195.7	126.6	154.9	183.4	116.5	143.3	170.1	
	67		TC	195.9	195.9	197.6	184.3	184.3	191.3	172.2	172.2	185.0	159.5	159.5	178.1	146.2	146.2	170.6	
			SHC	124.2	160.9	197.6	118.1	154.7	191.3	111.9	148.5	185.0	105.4	141.8	178.1	98.6	134.6	170.6	
	72	TC	215.2	215.2	215.2	202.6	202.6	202.6	189.5	189.5	189.5	175.7	175.7	175.7	161.0	161.0	161.0		
		SHC	88.6	125.5	162.3	82.7	119.4	156.2	76.5	113.3	150.1	70.2	106.9	143.5	63.6	100.2	136.8		
	76	TC	-	231.7	231.7	-	218.5	218.5	-	204.7	204.7	-	189.7	189.7	-	174.4	174.4		
		SHC	-	96.9	134.6	-	91.0	128.6	-	84.9	122.4	-	78.5	115.8	-	72.0	109.2		

LEGEND:

- - Do not operate
- Cfm - Cubic feet per minute (supply air)
- EAT (db) - Entering Air Temperature (dry bulb)
- EAT (wb) - Entering Air Temperature (wet bulb)
- SHC - Sensible Heat Capacity (1000 Btuh) Gross
- TC - Total Capacity (1000 Btuh) Gross

Table 30 – COOLING CAPACITIES - THIRD STAGE, FULL LOAD

23 TONS

26 SIZE			AMBIENT TEMPERATURE																
			85°F			95°F			105°F			115°F			125°F				
			EAT (db)			EAT (db)			EAT (db)			EAT (db)			EAT (db)				
			75	80	85	75	80	85	75	80	85	75	80	85	75	80	85		
6750 Cfm	EAT (wb)	58	TC	236.0	236.0	267.5	224.8	224.8	255.5	212.8	212.8	242.3	200.0	200.0	228.2	186.1	186.1	212.9	
			SHC	204.3	236.0	267.5	194.3	224.8	255.5	183.4	212.8	242.3	171.8	200.0	228.2	159.3	186.1	212.9	
		62	TC	249.9	249.9	249.9	236.2	236.2	236.6	222.1	222.1	228.0	206.8	206.8	218.7	190.5	190.5	208.8	
			SHC	180.1	212.6	245.0	171.7	204.2	236.6	163.1	195.6	228.0	154.1	186.4	218.7	144.5	176.7	208.8	
		67	TC	275.4	275.4	275.4	260.8	260.8	260.8	245.4	245.4	245.4	228.7	228.7	228.7	210.9	210.9	210.9	
			SHC	149.4	181.9	214.6	141.1	173.6	206.3	132.5	165.1	197.6	123.5	156.1	188.6	114.1	146.6	179.1	
	72	TC	304.3	304.3	304.3	288.6	288.6	288.6	271.7	271.7	271.7	254.1	254.1	254.1	234.9	234.9	234.9		
		SHC	118.3	151.4	184.6	110.1	143.2	176.3	101.5	134.6	167.6	92.7	125.7	158.5	83.5	116.3	149.2		
	76	TC	-	328.7	328.7	-	312.0	312.0	-	294.3	294.3	-	275.2	275.2	-	255.1	255.1		
		SHC	-	126.5	162.7	-	118.4	154.2	-	109.8	145.3	-	100.9	135.9	-	91.7	126.4		
	7900 Cfm	EAT (wb)	58	TC	249.9	249.9	283.1	237.8	237.8	269.9	225.1	225.1	256.0	211.5	211.5	241.0	196.9	196.9	224.9
				SHC	216.6	249.9	283.1	205.7	237.8	269.9	194.3	225.1	256.0	181.9	211.5	241.0	168.8	196.9	224.9
62			TC	258.9	258.9	268.2	244.8	244.8	259.5	230.2	230.2	250.4	214.6	214.6	240.4	198.1	198.1	229.5	
			SHC	194.1	231.2	268.2	185.6	222.6	259.5	176.8	213.5	250.4	167.3	203.9	240.4	157.2	193.3	229.5	
67			TC	284.4	284.4	284.4	269.0	269.0	269.0	252.8	252.8	252.8	235.5	235.5	235.5	216.8	216.8	216.8	
			SHC	158.7	196.1	233.3	150.2	187.5	224.7	141.6	178.7	216.0	132.4	169.6	206.7	122.8	159.9	197.0	
72		TC	313.6	313.6	313.6	297.1	297.1	297.1	279.6	279.6	279.6	261.0	261.0	261.0	241.1	241.1	241.1		
		SHC	122.9	160.8	198.5	114.7	152.3	190.0	105.9	143.5	181.2	96.9	134.5	172.0	87.5	124.9	162.3		
76		TC	-	338.2	338.2	-	320.7	320.7	-	302.2	302.2	-	282.4	282.4	-	261.4	261.4		
		SHC	-	132.1	172.5	-	123.7	163.8	-	115.1	154.8	-	106.0	145.5	-	96.6	135.8		
9000 Cfm		EAT (wb)	58	TC	260.7	260.7	295.1	248.1	248.1	281.5	234.9	234.9	266.9	220.4	220.4	251.1	205.1	205.1	234.1
				SHC	226.2	260.7	295.1	214.9	248.1	281.5	202.9	234.9	266.9	189.9	220.4	251.1	176.1	205.1	234.1
	62		TC	266.1	266.1	288.6	251.9	251.9	279.4	237.0	237.0	269.4	221.2	221.2	258.1	205.2	205.2	244.0	
			SHC	206.5	247.6	288.6	197.6	238.6	279.4	188.4	228.8	269.4	178.2	218.1	258.1	166.5	205.2	244.0	
	67		TC	291.0	291.0	291.0	275.2	275.2	275.2	258.3	258.3	258.3	240.4	240.4	240.4	221.2	221.2	221.2	
			SHC	167.0	208.6	250.1	158.4	199.9	241.4	149.5	190.9	232.3	140.2	181.5	223.0	130.5	171.8	213.1	
	72	TC	320.5	320.5	320.5	303.5	303.5	303.5	285.4	285.4	285.4	266.1	266.1	266.1	245.6	245.6	245.6		
		SHC	126.9	169.0	211.0	118.5	160.4	202.3	109.6	151.5	193.3	100.4	142.3	184.0	90.9	132.5	174.1		
	76	TC	-	345.2	345.2	-	327.2	327.2	-	308.0	308.0	-	287.6	287.6	-	266.1	266.1		
		SHC	-	136.9	181.3	-	128.4	172.5	-	119.6	163.4	-	110.5	154.0	-	100.9	144.2		
	10150 Cfm	EAT (wb)	58	TC	270.4	270.4	306.0	257.3	257.3	291.6	243.4	243.4	276.4	228.5	228.5	260.0	212.6	212.6	242.4
				SHC	234.8	270.4	306.0	223.0	257.3	291.6	210.4	243.4	276.4	197.0	228.5	260.0	182.6	212.6	242.4
62			TC	272.9	272.9	307.7	258.6	258.6	297.6	243.4	243.4	287.3	228.8	228.8	270.9	212.7	212.7	252.6	
			SHC	218.1	263.0	307.7	208.8	253.2	297.6	199.4	243.4	287.3	186.7	228.8	270.9	172.9	212.7	252.6	
67			TC	296.7	296.7	296.7	280.3	280.3	280.3	263.0	263.0	263.0	244.5	244.5	244.5	225.1	225.1	229.2	
			SHC	175.0	220.8	266.7	166.3	212.1	257.9	157.3	203.0	248.7	147.8	193.5	239.3	138.1	183.6	229.2	
72		TC	326.3	326.3	326.3	308.8	308.8	308.8	290.2	290.2	290.2	270.4	270.4	270.4	249.5	249.5	249.5		
		SHC	130.7	177.0	223.3	122.1	168.3	214.5	113.1	159.2	205.3	103.8	149.9	195.9	94.2	140.1	185.9		
76		TC	-	351.3	351.3	-	332.7	332.7	-	313.0	313.0	-	292.1	292.1	-	270.0	270.0		
		SHC	-	141.5	189.9	-	132.9	181.2	-	123.9	172.0	-	114.8	162.5	-	105.1	152.6		
11250 Cfm		EAT (wb)	58	TC	278.5	278.5	314.9	264.8	264.8	300.1	250.5	250.5	284.3	235.1	235.1	267.3	218.6	218.6	249.1
				SHC	241.9	278.5	314.9	229.6	264.8	300.1	216.6	250.5	284.3	202.8	235.1	267.3	188.0	218.6	249.1
	62		TC	278.4	278.4	327.1	264.9	264.9	311.9	250.8	250.8	295.9	235.4	235.4	278.4	218.8	218.8	259.5	
			SHC	229.6	278.4	327.1	217.9	264.9	311.9	205.5	250.8	295.9	192.3	235.4	278.4	177.9	218.8	259.5	
	67		TC	301.0	301.0	301.0	284.3	284.3	284.3	266.6	266.6	266.6	248.0	248.0	254.0	228.2	228.2	243.8	
			SHC	182.2	232.1	281.8	173.5	223.2	272.9	164.3	214.0	263.7	154.8	204.5	254.0	144.9	194.3	243.8	
	72	TC	330.8	330.8	330.8	313.0	313.0	313.0	293.9	293.9	293.9	273.8	273.8	273.8	252.4	252.4	252.4		
		SHC	133.9	184.2	234.4	125.3	175.4	225.5	116.2	166.2	216.3	106.9	156.8	206.7	97.1	146.9	196.7		
	76	TC	-	356.0	356.0	-	337.0	337.0	-	316.8	316.8	-	295.5	295.5	-	273.0	273.0		
		SHC	-	145.6	197.9	-	136.9	189.1	-	127.9	179.8	-	118.6	170.2	-	108.8	160.3		

LEGEND:

- - Do not operate
- Cfm - Cubic feet per minute (supply air)
- EAT (db) - Entering Air Temperature (dry bulb)
- EAT (wb) - Entering Air Temperature (wet bulb)
- SHC - Sensible Heat Capacity (1000 Btuh) Gross
- TC - Total Capacity (1000 Btuh) Gross

48LC*A26 REHEAT MODE #1 CAPACITIES (MBTUH), STANDARD UNITS

Reheat-1 (Subcooler Mode)		AIR ENTERING EVAPORATOR - SCFM/BF (80db)								
		6750			9000			11250		
Outdoor Air Temp ° F		Air Entering Evaporator -- Ewb (F)								
		72	67	62	72	67	62	72	67	62
75	TC	291	288	259	337	303	274	344	310	284
	SHC	116	171	203	157	198	239	170	220	270
	kW	30.0	20.3	19.8	22.7	22.1	21.4	24.7	24.0	23.2
85	TC	301	270	242	316	284	257	323	290	265
	SHC	123	155	187	139	180	223	151	201	252
	kW	22.6	22.0	21.5	24.4	23.8	23.2	26.4	25.8	24.9
95	TC	282	252	225	294	264	238	301	270	246
	SHC	105	138	171	119	162	206	131	183	234
	kW	24.6	24.0	23.4	26.3	25.7	25.1	28.4	27.7	26.8
105	TC	261	233	208	273	244	219	278	248	226
	SHC	86	121	155	100	144	188	110	163	215
	kW	26.8	26.2	25.6	28.6	27.9	27.3	30.6	29.9	29.0
115	TC	240	213	189	250	223	200	254	226	206
	SHC	68	103	138	79	124	170	89	143	196
	kW	29.2	28.6	28.1	31.0	30.4	29.7	33.0	32.3	31.4
125	TC	218	192	170	227	200	179	229	203	184
	SHC	48	84	121	59	105	151	67	122	176
	kW	32.0	31.4	30.8	33.8	33.1	32.4	35.7	35.0	34.1

LEGEND AND NOTES

- kW --- Compressor Power Input
- SHC --- Sensible Heat Capacity (1000 Btuh) Gross
- TC --- Total Capacity (1000 Btuh) Gross

48LC*A26 REHEAT MODE #2 CAPACITIES (MBTUH), STANDARD UNITS

Reheat-2 (Hot Gas Reheat Mode)		AIR ENTERING EVAPORATOR - SCFM/BF (80db)								
		6750			9000			11250		
Outdoor Air Temp ° F		Air Entering Evaporator -- Ewb (F)								
		62.5	64	65.3	62.5	64	65.3	62.5	64	65.3
80	TC	119	124	128	125	130	133	129	133	137
	SHC	31	18	7	49	33	19	67	48	31
	kW	22.3	22.7	23.0	22.8	23.1	23.4	23.0	23.4	23.6
75	TC	127	132	136	133	138	142	137	141	145
	SHC	38	26	15	56	40	26	75	56	39
	kW	21.3	21.7	21.9	21.8	22.1	22.4	22.1	22.3	22.6
70	TC	134	139	143	141	146	150	145	150	154
	SHC	45	33	22	64	48	34	82	63	47
	kW	20.4	20.7	21.0	20.8	21.1	21.4	21.1	21.4	21.7
60	TC	149	154	159	157	162	166	161	166	170
	SHC	60	47	36	78	63	49	98	79	63
	kW	18.6	18.9	19.2	19.1	19.4	19.6	19.4	19.7	19.9
50	TC	164	169	174	172	178	182	177	182	187
	SHC	74	62	51	94	78	65	113	95	79
	kW	17.1	17.4	17.6	17.5	17.8	18.1	17.8	18.1	18.4
40	TC	179	185	190	188	194	199	193	199	204
	SHC	89	77	67	109	94	81	129	111	96
	kW	15.7	16.0	16.3	16.2	16.5	16.7	16.5	16.7	17.0

LEGEND AND NOTES

- kW --- Compressor Power Input
- SHC --- Sensible Heat Capacity (1000 Btuh) Gross
- TC --- Total Capacity (1000 Btuh) Gross

Table 32 – STATIC PRESSURE ADDERS (IN. WG) (FACTORY OPTIONS AND/OR ACCESSORIES)

Ultra Low Leak Economizers

12.5 – 23 Tons								
CFM	3750	4250	4750	5250	5750	6250	6750	7250
Pressure Drop (in. wg)	0.04	0.04	0.05	0.06	0.06	0.07	0.07	0.08
CFM	7750	8250	8750	9250	9750	10250	10750	11250
Pressure Drop (in. wg)	0.08	0.09	0.08	0.10	0.10	0.11	0.11	0.12

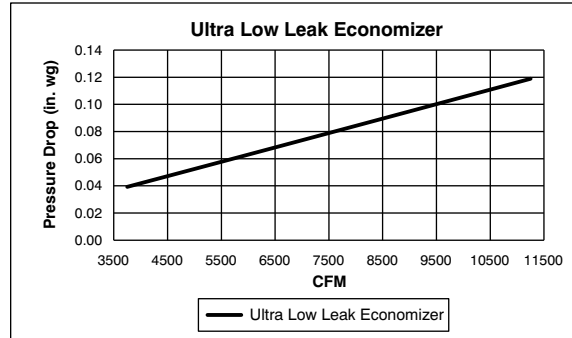

C160063

Humidi-MiZer® Coil

12.5 Tons								
CFM	2500	2750	3000	3250	3500	3750	4000	4250
Pressure Drop (in. wg)	0.02	0.02	0.02	0.02	0.03	0.03	0.03	0.03
CFM	4500	4750	5000	5250	5500	5750	6000	6250
Pressure Drop (in. wg)	0.04	0.04	0.04	0.04	0.05	0.05	0.05	0.06

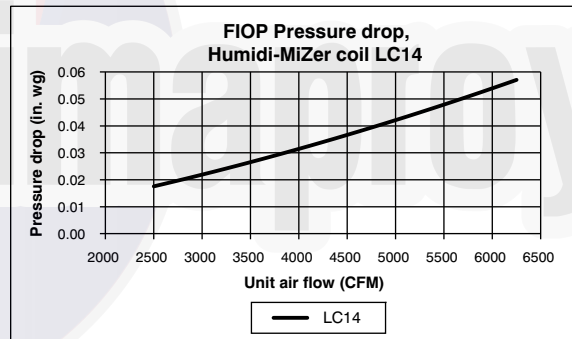

C160077

15–23 Tons								
CFM	3750	4250	4750	5250	5750	6250	6750	7250
Pressure Drop (in. wg)	0.02	0.03	0.03	0.04	0.04	0.05	0.05	0.06
CFM	7750	8250	8750	9250	9750	10250	10750	11250
Pressure Drop (in. wg)	0.06	0.07	0.07	0.08	0.09	0.09	0.10	0.11

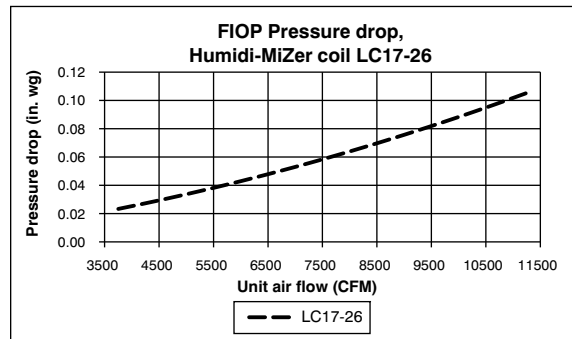

C160078

ECONOMIZER, BAROMETRIC RELIEF AND PE PERFORMANCE

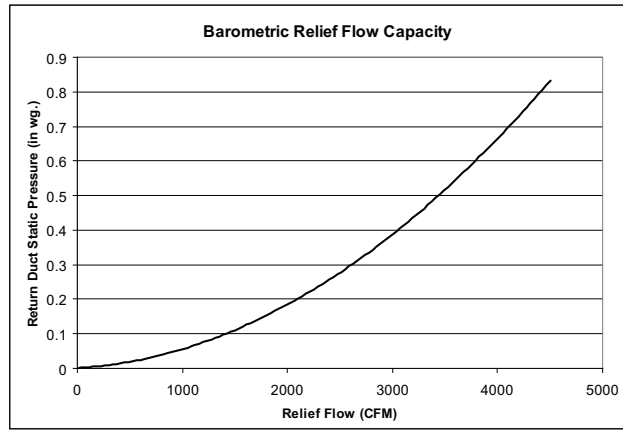

Fig. 14 - Barometric Relief Flow Capacity

C13107

Power Exhaust Fan Performance

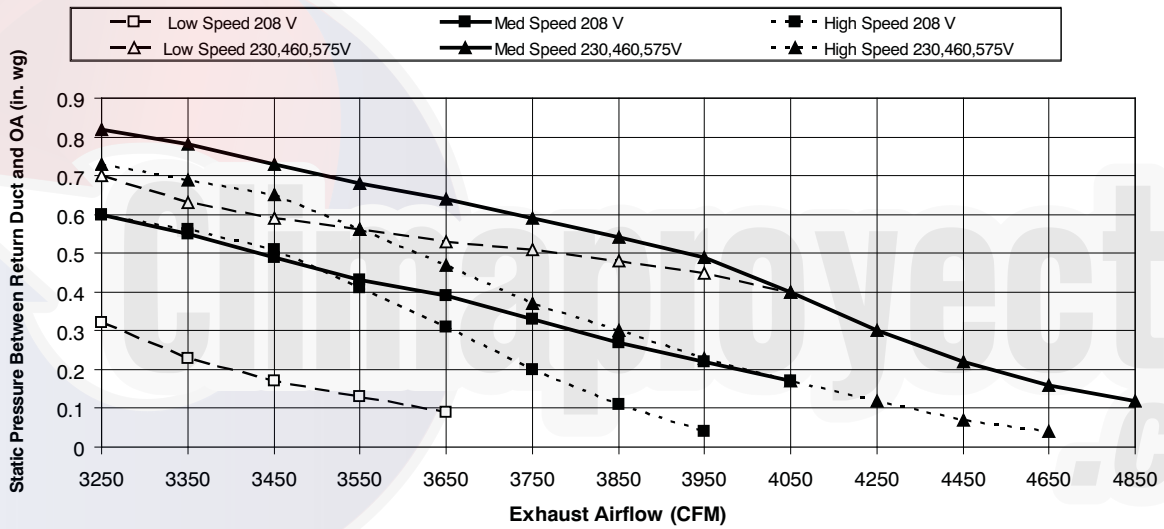

Fig. 15 - Power Exhaust Performance

C09270A

GENERAL FAN PERFORMANCE NOTES:

1. Interpolation is permissible. Do not extrapolate.
2. External static pressure is the static pressure difference between the return duct and the supply duct plus the static pressure caused by any FIOPs or accessories.
3. Tabular data accounts for pressure loss due to clean filters, unit casing, and wet coils. Factory options and accessories may add static pressure losses. Selection software is available, through your salesperson, to help you select the best motor/drive combination for your application.
4. The Fan Performance tables offer motor/drive recommendations. In cases when two motor/drive combinations would work, Carrier recommended the lower horsepower option.
5. For information on the electrical properties of Carrier motors, please see the Electrical information section of this book.
6. For more information on the performance limits of Carrier motors, see the application data section of this book.
7. The EPACT (Energy Policy Act) regulates energy requirements for specific types of indoor fan motors. Motors regulated by EPACT include any general purpose, T-frame (three-digit, 143 and larger), single-speed, foot mounted, polyphase, squirrel cage induction motors of NEMA (National Electrical Manufacturers Association) design A and B, manufactured for use in the United States. Ranging from 1 to 200 Hp, these continuous-duty motors operate on 230 and 460 volt, 60 Hz power. If a motor does not fit into these specifications, the motor does not have to be replaced by an EPACT compliant energy-efficient motor. Variable-speed motors are exempt from EPACT compliance requirements.



FAN PERFORMANCE

Table 33 – 48LC**14

12.5 TON VERTICAL SUPPLY

CFM	Available External Static Pressure (in. wg)																			
	0.2		0.4		0.6		0.8		1.0		1.2		1.4		1.6		1.8		2.0	
	RPM	BHP	RPM	BHP	RPM	BHP	RPM	BHP	RPM	BHP	RPM	BHP	RPM	BHP	RPM	BHP	RPM	BHP	RPM	BHP
3750	453	0.48	547	0.69	630	0.91	704	1.13	771	1.36	832	1.60	889	1.85	942	2.09	992	2.35	1040	2.60
4063	474	0.58	564	0.80	644	1.03	716	1.27	782	1.52	843	1.77	899	2.03	952	2.29	1002	2.56	1049	2.83
4375	497	0.69	582	0.92	659	1.16	730	1.42	794	1.68	854	1.95	910	2.22	962	2.50	1012	2.78	1059	3.07
4688	520	0.81	601	1.05	675	1.31	744	1.58	807	1.86	866	2.14	921	2.43	973	2.72	1022	3.02	1069	3.32
5000	544	0.95	620	1.21	692	1.48	759	1.76	821	2.05	878	2.35	933	2.65	984	2.96	1033	3.27	1080	3.59
5313	568	1.11	641	1.38	710	1.66	774	1.95	835	2.26	892	2.57	945	2.89	996	3.21	1044	3.54	1090	3.87
5625	593	1.29	662	1.56	728	1.86	791	2.17	850	2.48	905	2.81	958	3.14	1008	3.48	1056	3.82	1102	4.17
5938	619	1.48	685	1.77	748	2.08	808	2.40	866	2.73	920	3.07	972	3.41	1021	3.77	1068	4.12	1114	4.48
6250	644	1.70	707	2.00	768	2.32	826	2.65	882	2.99	935	3.35	986	3.71	1035	4.07	1081	4.44	1126	4.82

STD Static (498 – 676 rpm) 2.9 Max BHP

MID Static (682 – 861 rpm) 4.9 Max BHP

HIGH Static (782 – 963 rpm) 7.4 Max BHP

Ultra High Static (933 – 1113 rpm) 9.9 Max BHP

Bold Face = Field Supplied Drive (Standard motor, motor pulley = KR11HY216, blower pulley = KR51BM415, belt = KR30BE050) 435 – 570 rpm

Italics = Field Supplied Motor and Drive (Ultra High Static motor, motor pulley = KR12HY167, blower pulley = KR52BH615, belt = BX41) 948 – 1190 rpm

Table 34 – 48LC**14

12.5 TON HORIZONTAL SUPPLY

CFM	Available External Static Pressure (in. wg)																			
	0.2		0.4		0.6		0.8		1.0		1.2		1.4		1.6		1.8		2.0	
	RPM	BHP	RPM	BHP	RPM	BHP	RPM	BHP	RPM	BHP	RPM	BHP	RPM	BHP	RPM	BHP	RPM	BHP	RPM	BHP
3750	461	0.76	541	1.16	609	1.61	669	2.08	724	2.59	774	3.12	820	3.68	864	4.26	905	4.86	944	5.49
4063	485	0.90	562	1.32	628	1.79	687	2.28	741	2.81	790	3.37	836	3.94	880	4.55	921	5.17	959	5.81
4375	510	1.05	584	1.50	648	1.98	706	2.50	759	3.05	807	3.63	853	4.23	896	4.85	936	5.50	975	6.16
4688	535	1.23	606	1.70	669	2.20	725	2.75	777	3.32	825	3.91	870	4.53	912	5.18	953	5.84	991	6.53
5000	561	1.42	629	1.92	690	2.45	745	3.01	796	3.60	843	4.22	888	4.86	930	5.53	969	6.21	1007	6.92
5313	587	1.64	652	2.16	711	2.71	765	3.30	815	3.91	862	4.55	906	5.21	947	5.90	986	6.61	1024	7.33
5625	614	1.89	677	2.42	734	3.00	786	3.61	835	4.24	881	4.91	924	5.59	965	6.30	1004	7.03	1041	7.78
5938	641	2.16	701	2.72	756	3.32	808	3.95	855	4.60	900	5.29	943	6.00	983	6.72	1022	7.47	1059	8.24
6250	668	2.45	726	3.04	780	3.66	830	4.31	876	4.99	920	5.70	962	6.43	1002	7.18	1040	7.95	1077	8.74

STD Static (498 – 676 rpm) 2.9 Max BHP

Mid Static (644 – 808 rpm) 4.9 Max BHP*

HIGH Static (782 – 963 rpm) 7.4 Max BHP

ULTRA HIGH Static (933 – 1113 rpm) 9.9 Max BHP

*At 575V, Max BHP is 4.7

Bold Face = Field Supplied Drive (Standard motor, motor pulley = KR11HY163, blower pulley = KR51BM415, belt = KR29AF049) 368 – 509rpm

FAN PERFORMANCE (cont.)

Table 35 – 48LC17**

15 TON VERTICAL SUPPLY

CFM	Available External Static Pressure (in. wg)																			
	0.2		0.4		0.6		0.8		1.0		1.2		1.4		1.6		1.8		2.0	
	RPM	BHP	RPM	BHP	RPM	BHP	RPM	BHP	RPM	BHP	RPM	BHP	RPM	BHP	RPM	BHP	RPM	BHP	RPM	BHP
4500	508	0.79	603	1.12	679	1.44	745	1.76	806	2.09	863	2.43	918	2.79	971	3.16	1022	3.55	1071	3.96
4875	532	0.94	626	1.31	701	1.65	765	1.99	825	2.34	880	2.70	933	3.07	984	3.46	1033	3.86	1081	4.28
5250	556	1.11	649	1.51	723	1.89	787	2.25	845	2.62	899	3.00	950	3.39	999	3.79	1047	4.20	1093	4.63
5625	581	1.30	672	1.73	746	2.14	809	2.54	866	2.93	918	3.33	968	3.73	1016	4.15	1062	4.58	1107	5.02
6000	607	1.51	695	1.98	768	2.42	831	2.85	887	3.27	939	3.69	988	4.11	1035	4.55	1079	4.99	1123	5.45
6375	634	1.75	719	2.24	791	2.73	854	3.19	909	3.63	960	4.08	1008	4.53	1054	4.98	1098	5.44	1140	5.91
6750	662	2.02	743	2.54	815	3.05	876	3.55	932	4.03	982	4.50	1029	4.97	1074	5.45	1117	5.93	1159	6.41
7125	690	2.33	767	2.86	838	3.41	899	3.94	954	4.45	1004	4.95	1051	5.45	1095	5.95	1138	6.45	—	—
7500	719	2.66	791	3.20	861	3.79	922	4.35	977	4.90	1027	5.43	1073	5.96	1117	6.48	1159	7.01	—	—

STD Static (555 – 753 rpm) 2.9 Max BHP

MID Static (707 – 888 rpm) 7.4 Max BHP

HIGH Static (872 – 1053 rpm) 9.9 Max BHP

ULTRA HIGH Static (1049 – 1291 rpm) 13.6 Max BHP

Bold Face = Field Supplied Drive (Standard motor, motor pulley = KR11HY216, blower pulley = KR51BM415, belt = KR30BE050) 435 – 570 rpm

Table 36 – 48LC17**

15 TON HORIZONTAL SUPPLY

CFM	Available External Static Pressure (in. wg)																			
	0.2		0.4		0.6		0.8		1.0		1.2		1.4		1.6		1.8		2.0	
	RPM	BHP	RPM	BHP	RPM	BHP	RPM	BHP	RPM	BHP	RPM	BHP	RPM	BHP	RPM	BHP	RPM	BHP	RPM	BHP
4500	526	1.35	601	1.89	667	2.50	726	3.14	779	3.81	828	4.50	873	5.22	915	5.95	954	6.71	992	7.48
4875	557	1.62	628	2.19	692	2.83	749	3.50	802	4.20	850	4.93	895	5.69	937	6.46	976	7.26	1013	8.06
5250	589	1.93	656	2.53	717	3.20	774	3.90	825	4.64	873	5.41	917	6.20	959	7.01	998	7.84	1035	8.68
5625	621	2.28	685	2.91	744	3.61	798	4.34	849	5.12	896	5.92	940	6.74	981	7.59	1020	8.46	1058	9.34
6000	654	2.68	714	3.34	771	4.07	824	4.83	873	5.64	920	6.47	963	7.33	1004	8.22	1043	9.12	1080	10.04
6375	687	3.13	745	3.82	799	4.57	850	5.37	899	6.21	944	7.08	987	7.97	1027	8.89	1066	9.83	—	—
6750	721	3.63	775	4.35	828	5.13	877	5.96	924	6.83	969	7.73	1011	8.65	1051	9.61	1089	10.58	—	—
7125	755	4.19	807	4.94	857	5.75	905	6.60	951	7.50	994	8.43	1035	9.39	1075	10.38	—	—	—	—
7500	789	4.80	839	5.58	887	6.42	933	7.31	977	8.23	1020	9.19	1060	10.19	1099	11.21	—	—	—	—

STD Static (525 – 713 rpm) 2.9 Max BHP

MID Static (707 – 888 rpm) 7.4 Max BHP

HIGH Static (872 – 1053 rpm) 9.9 Max BHP

ULTRA HIGH Static (948 – 1190 rpm) 13.6 Max BHP

Bold Face = Field Supplied Drive (Mid Static Motor, motor pulley = KR11HY232, blower pulley = KR51BQ415, belt = KR29BF059) 583 – 717 rpm

FAN PERFORMANCE (cont.)

Table 37 – 48LC**20

17.5 TON VERTICAL SUPPLY

CFM	Available External Static Pressure (in. wg)																			
	0.2		0.4		0.6		0.8		1.0		1.2		1.4		1.6		1.8		2.0	
	RPM	BHP	RPM	BHP	RPM	BHP	RPM	BHP	RPM	BHP	RPM	BHP	RPM	BHP	RPM	BHP	RPM	BHP	RPM	BHP
5250	556	1.11	649	1.51	723	1.89	787	2.25	845	2.62	899	3.00	950	3.39	999	3.79	1047	4.20	1093	4.63
5688	586	1.33	676	1.77	749	2.19	812	2.59	869	2.99	922	3.39	972	3.80	1019	4.21	1065	4.64	1109	5.09
6125	616	1.59	703	2.06	776	2.52	838	2.96	894	3.39	946	3.81	995	4.25	1041	4.69	1085	5.14	1128	5.60
6563	648	1.89	731	2.39	803	2.89	865	3.36	920	3.83	971	4.28	1019	4.74	1064	5.21	1107	5.68	1149	6.16
7000	681	2.22	759	2.75	830	3.29	892	3.80	947	4.30	997	4.80	1044	5.28	1088	5.78	1131	6.27	1172	6.77
7438	714	2.60	787	3.14	857	3.72	918	4.28	973	4.82	1023	5.35	1069	5.87	1113	6.39	1155	6.91	-	-
7875	748	3.03	817	3.58	884	4.20	945	4.80	1000	5.38	1049	5.95	1095	6.50	1139	7.05	-	-	-	-
8313	783	3.50	847	4.07	912	4.72	972	5.36	1027	5.98	1076	6.59	1122	7.18	1165	7.76	-	-	-	-
8750	819	4.03	878	4.61	941	5.28	1000	5.96	1054	6.63	1103	7.27	1148	7.90	-	-	-	-	-	-

STD Static (676 – 854 rpm) 2.9 Max BHP

MID Static (782 – 963 rpm) 7.4 Max BHP

HIGH Static (933 – 1113 rpm) 9.9 Max BHP

ULTRA HIGH Static (1049 – 1291 rpm) 13.6 Max BHP

Bold Face = Field Supplied Drive (Standard Motor (HD60FE656), motor pulley = KR11HY163, blower pulley = KR51BM615, belt = KR29BF042) 555 – 753 rpm

Italics = Field Supplied Drive (Medium Static Motor (HD60FK657), motor pulley = KR11HY194, blower pulley = KR51BM419, belt = KR28BF051) 651 – 818 rpm

Table 38 – 48LC**20

17.5 TON HORIZONTAL SUPPLY

CFM	Available External Static Pressure (in. wg)																			
	0.2		0.4		0.6		0.8		1.0		1.2		1.4		1.6		1.8		2.0	
	RPM	BHP	RPM	BHP	RPM	BHP	RPM	BHP	RPM	BHP	RPM	BHP	RPM	BHP	RPM	BHP	RPM	BHP	RPM	BHP
5250	589	1.93	656	2.53	717	3.20	774	3.90	825	4.64	873	5.41	917	6.20	959	7.01	998	7.84	1035	8.68
5688	626	2.34	690	2.98	748	3.68	803	4.42	853	5.20	900	6.01	944	6.84	985	7.69	1024	8.57	1061	9.46
6125	665	2.82	724	3.50	780	4.23	833	5.01	882	5.82	928	6.67	971	7.54	1012	8.43	1050	9.35	1087	10.29
6563	704	3.37	760	4.08	813	4.84	864	5.66	911	6.51	956	7.39	999	8.31	1039	9.24	1077	10.20	-	-
7000	743	4.00	796	4.74	847	5.53	896	6.38	942	7.27	985	8.19	1027	9.14	1067	10.12	-	-	-	-
7438	783	4.70	833	5.47	882	6.30	928	7.18	973	8.11	1015	9.06	1056	10.05	1095	11.06	-	-	-	-
7875	823	5.48	871	6.29	917	7.15	962	8.07	1005	9.03	1046	10.02	1086	11.04	-	-	-	-	-	-
8313	864	6.35	909	7.19	953	8.09	996	9.04	1038	10.03	1078	11.06	-	-	-	-	-	-	-	-
8750	905	7.31	948	8.19	990	9.13	1031	10.11	1071	11.13	-	-	-	-	-	-	-	-	-	-

STD Static (555 – 753 rpm) 2.9 Max BHP

MID Static (707 – 888 rpm) 7.4 Max BHP

HIGH Static (872 – 1053 rpm) 9.9 Max BHP

ULTRA HIGH Static (948 – 1190 rpm) 13.6 Max BHP

Bold Face = Field Supplied Drive (Mid Static Motor (HD60FK657), motor pulley = KR11HY232, blower pulley = KR51BQ415, belt = KR29BF059) 583 – 717 rpm



FAN PERFORMANCE (cont.)

Table 39 – 48LC24**

20 TON VERTICAL SUPPLY

CFM	Available External Static Pressure (in. wg)																							
	0.2		0.4		0.6		0.8		1.0		1.2		1.4		1.6		1.8		2.0					
	RPM	BHP	RPM	BHP	RPM	BHP	RPM	BHP	RPM	BHP	RPM	BHP	RPM	BHP	RPM	BHP	RPM	BHP	RPM	BHP				
6000	607	1.51	695	1.98	768	2.42	831	2.85	887	3.27	939	3.69	988	4.11	1034	4.55	1079	4.99	1123	5.45				
6500	643	1.84	727	2.34	799	2.83	861	3.30	917	3.76	968	4.22	1015	4.67	1061	5.13	1104	5.60	1146	6.07				
7000	681	2.22	759	2.75	830	3.29	892	3.81	947	4.30	997	4.80	1044	5.28	1088	5.78	1131	6.27	1172	6.77				
7500	719	2.66	791	3.20	861	3.79	922	4.35	977	4.90	1027	5.43	1073	5.96	1117	6.48	1159	7.01	1199	7.54				
8000	758	3.16	825	3.72	893	4.34	953	4.96	1008	5.55	1057	6.13	1103	6.69	1146	7.25	1187	7.81	1227	8.37				
8500	798	3.72	860	4.30	924	4.95	984	5.61	1038	6.25	1088	6.88	1133	7.48	1176	8.08	1217	8.68	1255	9.27				
9000	839	4.35	896	4.94	957	5.62	1016	6.33	1069	7.01	1118	7.68	1164	8.34	1206	8.98	1246	9.61	1285	10.24				
9500	880	5.06	933	5.66	990	6.36	1047	7.10	1100	7.84	1149	8.56	1194	9.26	1237	9.94	1277	10.62	-	-				
10000	922	5.84	970	6.45	1025	7.17	1079	7.94	1131	8.72	1180	9.49	1225	10.24	1267	10.97	-	-	-	-				

STD Static (707 – 888 rpm) 7.4 Max BHP

MID Static (872 – 1053 rpm) 9.9 Max BHP

HIGH Static (1049 – 1291 rpm) 13.6 Max BHP

Bold Face = Field Supplied Drive (Standard Motor (HD60FK657), motor pulley = KR11HY232, blower pulley = KR51BQ415, belt = KR29BF059) 583 – 717 rpm

Table 40 – 48LC24**

20 TON HORIZONTAL SUPPLY

CFM	Available External Static Pressure (in. wg)																							
	0.2		0.4		0.6		0.8		1.0		1.2		1.4		1.6		1.8		2.0					
	RPM	BHP	RPM	BHP	RPM	BHP	RPM	BHP	RPM	BHP	RPM	BHP	RPM	BHP	RPM	BHP	RPM	BHP	RPM	BHP				
6000	654	2.68	714	3.34	771	4.07	824	4.83	873	5.64	920	6.47	963	7.33	1004	8.22	1043	9.12	1080	10.04				
6500	698	3.29	755	3.99	809	4.75	859	5.56	907	6.41	952	7.29	995	8.19	1035	9.12	1073	10.07	1110	11.04				
7000	743	4.00	796	4.74	847	5.53	896	6.38	942	7.27	985	8.19	1027	9.14	1067	10.12	1104	11.11	1140	12.13				
7500	789	4.80	839	5.58	887	6.42	933	7.31	977	8.23	1020	9.19	1060	10.19	1099	11.21	1136	12.25	1172	13.31				
8000	835	5.72	882	6.54	928	7.41	972	8.34	1014	9.31	1055	10.31	1094	11.34	1132	12.40	1169	13.49	-	-				
8500	881	6.75	926	7.61	969	8.53	1011	9.49	1052	10.49	1092	11.53	1130	12.61	-	-	-	-	-	-				
9000	928	7.91	970	8.81	1011	9.76	1052	10.76	1091	11.81	1129	12.89	-	-	-	-	-	-	-	-				
9500	975	9.20	1015	10.14	1054	11.13	1093	12.17	1130	13.25	-	-	-	-	-	-	-	-	-	-				
10000	1022	10.62	1060	11.60	1098	12.64	-	-	-	-	-	-	-	-	-	-	-	-	-	-				

STD Static (707 – 888 rpm) 7.4 Max BHP

MID Static (859 – 1026 rpm) 9.9 Max BHP

HIGH Static (948 – 1190 rpm) 13.6 Max BHP

Bold Face = Field Supplied Drive (Standard Motor (HD60FK657), motor pulley = KR11HY232, blower pulley = KR51BQ415, belt = KR29BF059) 583 – 717 rpm

FAN PERFORMANCE (cont.)

Table 41 – 48LC26**

23 TON VERTICAL SUPPLY

CFM	Available External Static Pressure (in. wg)																							
	0.2		0.4		0.6		0.8		1.0		1.2		1.4		1.6		1.8		2.0					
	RPM	BHP	RPM	BHP	RPM	BHP	RPM	BHP	RPM	BHP	RPM	BHP	RPM	BHP	RPM	BHP	RPM	BHP	RPM	BHP				
6750	662	2.02	743	2.54	815	3.05	876	3.55	932	4.03	982	4.50	1029	4.97	1074	5.45	1117	5.93	1159	6.41				
7313	705	2.49	779	3.03	849	3.60	911	4.14	966	4.67	1016	5.19	1062	5.70	1106	6.21	1148	6.72	1188	7.24				
7875	749	3.03	817	3.59	885	4.20	945	4.80	1000	5.38	1050	5.95	1096	6.50	1139	7.05	1180	7.60	1219	8.15				
8438	793	3.65	856	4.22	920	4.87	980	5.53	1034	6.16	1084	6.78	1129	7.38	1172	7.97	1213	8.57	1252	9.16				
9000	839	4.35	896	4.94	957	5.62	1016	6.33	1069	7.01	1118	7.68	1164	8.34	1206	8.98	1246	9.61	1285	10.24				
9563	885	5.15	937	5.75	995	6.46	1051	7.20	1104	7.95	1153	8.67	1198	9.38	1240	10.07	1280	10.75	-	-				
10125	932	6.05	980	6.66	1033	7.38	1088	8.17	1139	8.96	1188	9.74	1233	10.50	1275	11.24	-	-	-	-				
10688	979	7.05	1023	7.67	1073	8.41	1125	9.22	1175	10.06	1223	10.89	1267	11.71	-	-	-	-	-	-				
11250	1026	8.16	1067	8.79	1114	9.55	1163	10.38	1211	11.26	1258	12.14	-	-	-	-	-	-	-	-				

STD Static (707 – 888 rpm) 7.4 Max BHP

MID Static (872 – 1053 rpm) 9.9 Max BHP

HIGH Static (1049 – 1291 rpm) 13.6 Max BHP

Bold Face = Field Supplied Drive (Standard Motor (HD60FK657), motor pulley = KR11HY232, blower pulley = KR51BQ415, belt = KR29BF059) 583–717 rpm

Table 42 – 48LC26**

23 TON HORIZONTAL SUPPLY

CFM	Available External Static Pressure (in. wg)																							
	0.2		0.4		0.6		0.8		1.0		1.2		1.4		1.6		1.8		2.0					
	RPM	BHP	RPM	BHP	RPM	BHP	RPM	BHP	RPM	BHP	RPM	BHP	RPM	BHP	RPM	BHP	RPM	BHP	RPM	BHP				
6750	719	3.61	774	4.33	826	5.10	876	5.93	923	6.79	967	7.69	1009	8.62	1049	9.57	1087	10.53	1124	11.52				
7313	770	4.46	821	5.22	870	6.04	918	6.91	963	7.82	1005	8.76	1046	9.74	1085	10.73	1123	11.76	1158	12.80				
7875	822	5.45	870	6.25	916	7.12	960	8.03	1003	8.98	1045	9.97	1084	10.99	1122	12.03	1159	13.11	-	-				
8438	874	6.58	919	7.43	962	8.33	1005	9.29	1046	10.28	1085	11.32	1124	12.38	1160	13.48	-	-	-	-				
9000	926	7.87	968	8.76	1010	9.71	1050	10.70	1089	11.74	1127	12.82	-	-	-	-	-	-	-	-				
9563	979	9.31	1019	10.25	1058	11.25	1096	12.29	1133	13.37	-	-	-	-	-	-	-	-	-	-				
10125	1032	10.94	1070	11.93	1107	12.96	-	-	-	-	-	-	-	-	-	-	-	-	-	-				
10688	1085	12.75	-	-	-	-	-	-	-	-	-	-	-	-	-	-	-	-	-	-				
11250	-	-	-	-	-	-	-	-	-	-	-	-	-	-	-	-	-	-	-	-				

STD Static (707 – 888 rpm) 7.4 Max BHP

MID Static (859 – 1026 rpm) 9.9 Max BHP

HIGH Static (948 – 1190 rpm) 13.6 Max BHP

FAN PERFORMANCE (cont.)

Table 43 – PULLEY ADJUSTMENT

VERTICAL

UNIT	MOTOR/DRIVE COMBO	MOTOR PULLEY TURNS OPEN (RPM)												
		0.0	0.5	1.0	1.5	2.0	2.5	3.0	3.5	4.0	4.5	5.0	5.5	6.0
14	Stand Static	N/A	N/A	676	658	640	623	605	587	569	551	534	516	498
	Med Static	N/A	N/A	861	843	825	807	789	772	754	736	718	700	682
	High Static	963	948	933	918	903	888	873	857	842	827	812	797	782
	Ultra High Static	1113	1098	1083	1068	1053	1038	1023	1008	993	978	963	948	933
17	Stand Static	N/A	N/A	753	733	713	694	674	654	634	614	595	575	555
	Med Static	888	873	858	843	828	813	798	782	767	752	737	722	707
	High Static	1053	1038	1023	1008	993	978	963	947	932	917	902	887	872
	Ultra High Static	1291	1271	1251	1231	1210	1190	1170	1150	1130	1110	1089	1069	1049
20	Stand Static	N/A	N/A	854	836	818	801	783	765	747	729	712	694	676
	Med Static	963	948	933	918	903	888	873	857	842	827	812	797	782
	High Static	1113	1098	1083	1068	1053	1038	1023	1008	993	978	963	948	933
	Ultra High Static	1291	1271	1251	1231	1210	1190	1170	1150	1130	1110	1089	1069	1049
24	Stand Static	888	873	858	843	828	813	798	782	767	752	737	722	707
	Med Static	1053	1038	1023	1008	993	978	963	947	932	917	902	887	872
	High Static	1291	1271	1251	1231	1210	1190	1170	1150	1130	1110	1089	1069	1049
26	Stand Static	888	873	858	843	828	813	798	782	767	752	737	722	707
	Med Static	1053	1038	1023	1008	993	978	963	947	932	917	902	887	872
	High Static	1291	1271	1251	1231	1210	1190	1170	1150	1130	1110	1089	1069	1049

48LC

Table 44 – PULLEY ADJUSTMENT

HORIZONTAL

UNIT	MOTOR/DRIVE COMBO	MOTOR PULLEY TURNS OPEN (RPM)												
		0.0	0.5	1.0	1.5	2.0	2.5	3.0	3.5	4.0	4.5	5.0	5.5	6.0
14	Stand Static	N/A	N/A	676	658	640	623	605	587	569	551	534	516	498
	Med Static	808	794	781	767	753	740	726	712	699	685	671	658	644
	High Static	963	948	933	918	903	888	873	857	842	827	812	797	782
	Ultra High Static	1113	1098	1083	1068	1053	1038	1023	1008	993	978	963	948	933
17	Stand Static	N/A	N/A	713	694	675	657	638	619	600	581	563	544	525
	Med Static	888	873	858	843	828	813	798	782	767	752	737	722	707
	High Static	1053	1038	1023	1008	993	978	963	947	932	917	902	887	872
	Ultra High Static	1190	1170	1150	1130	1109	1089	1069	1049	1029	1009	988	968	948
20	Stand Static	N/A	N/A	753	733	713	694	674	654	634	614	595	575	555
	Med Static	888	873	858	843	828	813	798	782	767	752	737	722	707
	High Static	1053	1038	1023	1008	993	978	963	947	932	917	902	887	872
	Ultra High Static	1190	1170	1150	1130	1109	1089	1069	1049	1029	1009	988	968	948
24	Stand Static	888	873	858	843	828	813	798	782	767	752	737	722	707
	Med Static	1026	1012	998	984	970	956	943	929	915	901	887	873	859
	High Static	1190	1170	1150	1130	1109	1089	1069	1049	1029	1009	988	968	948
26	Stand Static	888	873	858	843	828	813	798	782	767	752	737	722	707
	Med Static	1026	1012	998	984	970	956	943	929	915	901	887	873	859
	High Static	1190	1170	1150	1130	1109	1089	1069	1049	1029	1009	988	968	948

- – Factory settings
- Standard static uses direct drive motor

ELECTRICAL INFORMATION

Table 45 – 48LC*14-26

12.5 - 23 TONS

48LC UNIT	V-Ph-Hz	VOLTAGE RANGE		COMP 1		COMP 2		OFM (ea)		IFM		
		MIN	MAX	RLA	LRA	RLA	LRA	WATTS	FLA	TYPE	EFF at Full Load	FLA
14	208-3-60	187	253	17.6	123	23.2	164	185	1.3	STD	85.0%	8.6
										MED	83.6%	13.6
										HIGH	89.5%	21.2
										ULTRA HIGH	91.7%	28.0
	230-3-60	187	253	17.6	123	23.2	164	185	1.3	STD	85.0%	7.8
										MED	83.6%	12.7
										HIGH	89.5%	21.2
										ULTRA HIGH	91.7%	28.0
	460-3-60	414	506	9.6	62	11.2	75	185	1.3	STD	85.0%	3.8
										MED	83.6%	6.4
										HIGH	89.5%	9.7
										ULTRA HIGH	91.7%	13.7
	575-3-60	518	633	6.1	40	7.9	54	185	1.3	STD	81.1%	4.5
										MED	83.6%	6.2
										HIGH	89.5%	7.2
										ULTRA HIGH	91.7%	8.9
17	208-3-60	187	253	19.1	123	27.6	191	185	1.3	STD	85.0%	8.6
										MED	89.5%	21.2
										HIGH	91.7%	28.0
										ULTRA HIGH	91.7%	37.3
	230-3-60	187	253	19.1	123	27.6	191	185	1.3	STD	85.0%	7.8
										MED	89.5%	21.2
										HIGH	91.7%	28.0
										ULTRA HIGH	91.7%	37.3
	460-3-60	414	506	9.8	62	12.8	100	185	1.3	STD	85.0%	3.8
										MED	89.5%	9.7
										HIGH	91.7%	13.7
										ULTRA HIGH	91.7%	16.9
	575-3-60	518	633	7.5	50	10.2	78	185	1.3	STD	81.1%	4.5
										MED	89.5%	7.2
										HIGH	91.7%	8.9
										ULTRA HIGH	91.7%	12.6
20	208-3-60	187	253	25.0	164	27.6	191	185	1.3	STD	85.0%	8.6
										MED	89.5%	21.2
										HIGH	91.7%	28.0
										ULTRA HIGH	91.7%	37.3
	230-3-60	187	253	25.0	164	27.6	191	185	1.3	STD	85.0%	7.8
										MED	89.5%	21.2
										HIGH	91.7%	28.0
										ULTRA HIGH	91.7%	37.3
	460-3-60	414	506	12.2	100	12.8	100	185	1.3	STD	85.0%	3.8
										MED	89.5%	9.7
										HIGH	91.7%	13.7
										ULTRA HIGH	91.7%	16.9
	575-3-60	518	633	9.3	78	10.2	78	185	1.3	STD	81.1%	4.5
										MED	89.5%	7.2
										HIGH	91.7%	8.9
										ULTRA HIGH	91.7%	12.6

48LC

ELECTRICAL INFORMATION (cont.)

Table 45 (cont.) - 48LC*14- 26

12.5 - 23 TONS

48LC UNIT	V-Ph-Hz	VOLTAGE RANGE		COMP 1		COMP 2		OFM (ea)		IFM		
		MIN	MAX	RLA	LRA	RLA	LRA	WATTS	FLA	TYPE	EFF at Full Load	FLA
24	208-3-60	187	253	29.5	195	33.3	239	190	1.6	STD	89.5%	21.2
										MED	91.7%	28.0
										HIGH	91.7%	37.3
	230-3-60	187	253	29.5	195	33.3	239	190	1.6	STD	89.5%	21.2
										MED	91.7%	28.0
										HIGH	91.7%	37.3
	460-3-60	414	506	14.8	95	18.0	125	190	1.6	STD	89.5%	9.7
										MED	91.7%	13.7
										HIGH	91.7%	16.9
	575-3-60	518	633	12.2	80	12.8	80	190	1.6	STD	89.5%	7.2
										MED	91.7%	8.9
										HIGH	91.7%	12.6
26	208-3-60	187	253	30.1	225	51.2	300	190	1.6	STD	89.5%	21.2
										MED	91.7%	28.0
										HIGH	91.7%	37.3
	230-3-60	187	253	30.1	225	51.2	300	190	1.6	STD	89.5%	21.2
										MED	91.7%	28.0
										HIGH	91.7%	37.3
	460-3-60	414	506	16.7	114	23.1	150	190	1.6	STD	89.5%	9.7
										MED	91.7%	13.7
										HIGH	91.7%	16.9
	575-3-60	518	633	12.2	80	19.9	109	190	1.6	STD	89.5%	7.2
										MED	91.7%	8.9
										HIGH	91.7%	12.6

48LC

ELECTRICAL INFORMATION (cont.)

Table 46 – UNIT WIRE/FUSE OR HACR BREAKER SIZING DATA

48LC UNIT	NOM. V-Ph-Hz	IFM TYPE	NO C.O. or UNPWR C.O.						w/ PWRD C.O.									
			NO PE.			w/ PE. (pwrd fr/ unit)			NO PE.			w/ PWRD C.O.						
			MCA	MAX FUSE or HACR BRKR	DISC. SIZE FLA LRA	MCA	MAX FUSE or HACR BRKR	DISC. SIZE FLA LRA	MCA	MAX FUSE or HACR BRKR	DISC. SIZE FLA LRA	MCA	MAX FUSE or HACR BRKR	DISC. SIZE FLA LRA				
14	208/ 230-3-60	STD	59.1/58.3	80/80	61/60	343	70.9/70.1	90/90	75/74	363	63.9/63.1	80/80	67/66	348	75.7/74.9	90/90	80/79	368
		MED	64.1/63.2	80/80	67/66	378	75.9/75.0	90/90	81/80	398	68.9/68.0	90/90	73/72	383	80.7/79.8	100/100	86/85	403
		HIGH	71.7	90	76	382	83.5	100	89	402	76.5	90	81	387	88.3	100	95	407
		ULTRA HIGH	79.7	100	84	456	91.5	100	97	476	84.5	100	89	461	96.3	110	103	481
	460-3-60	STD	31.3	40	33	167	37.5	45	40	179	33.5	40	35	169	39.7	50	42	181
		MED	33.9	45	36	184	40.1	50	43	196	36.1	45	38	186	42.3	50	45	198
		HIGH	37.2	45	40	186	43.4	50	47	198	39.4	50	42	188	45.6	50	49	200
		ULTRA HIGH	41.8	50	44	223	48.0	60	51	235	44.0	50	47	225	50.2	60	54	237
	575-3-60	STD	24.4	30	26	119	29.2	35	31	127	26.1	30	28	121	30.9	35	33	129
		MED	26.1	30	28	133	30.9	35	33	141	27.8	30	30	135	32.6	40	35	143
		HIGH	27.1	30	29	131	31.9	35	34	139	28.8	35	31	133	33.6	40	36	141
		ULTRA HIGH	29.0	35	31	158	33.8	40	36	166	30.7	35	33	160	35.5	40	38	168
17	208/ 230-3-60	STD	67.4/66.6	90/90	70/69	371	79.2/78.4	100/100	83/82	391	72.2/71.4	90/90	75/74	376	84.0/83.2	100/100	89/88	396
		MED	80.0	100	84	410	91.8	100	98	430	84.8	100	90	415	96.6	110	103	435
		HIGH	86.9	100	92	484	98.7	125	105	504	91.7	100	97	489	103.5	125	111	509
		ULTRA HIGH	98.5	125	103	524	110.3	125	116	544	103.3	125	108	529	115.1	150	122	549
	460-3-60	STD	34.8	45	36	193	41.0	50	43	205	37.0	45	39	195	43.2	50	46	207
		MED	40.7	50	43	212	46.9	60	50	224	42.9	50	46	214	49.1	60	53	226
		HIGH	44.9	50	48	249	51.1	60	55	261	47.1	60	50	251	53.3	60	57	263
		ULTRA HIGH	48.9	60	51	269	55.1	60	59	281	51.1	60	54	271	57.3	70	61	283
	575-3-60	STD	30.0	40	32	154	34.8	40	37	162	31.7	40	33	156	36.5	45	39	164
		MED	32.7	40	35	166	37.5	45	40	174	34.4	40	37	168	39.2	45	42	176
		HIGH	34.4	40	37	193	39.2	45	42	201	36.1	45	39	195	40.9	50	44	203
		ULTRA HIGH	38.7	50	41	204	43.5	50	46	212	40.4	50	43	206	45.2	50	48	214
20	208/ 230-3-60	STD	73.3/72.5	100/100	76/75	412	85.1/84.3	100/100	90/89	432	78.1/77.3	100/100	82/81	417	89.9/89.1	100/100	95/95	437
		MED	85.9	100	91	451	97.7	125	104	471	90.7	100	96	456	102.5	125	110	476
		HIGH	92.8	100	99	525	104.6	125	112	545	97.6	125	104	530	109.4	125	118	550
		ULTRA HIGH	104.4	125	109	585	116.2	150	123	585	109.2	125	115	570	121.0	150	128	590
	460-3-60	STD	37.2	50	39	231	43.4	50	46	243	39.4	50	42	233	45.6	50	49	245
		MED	43.1	50	46	250	49.3	60	53	262	45.3	50	48	252	51.5	60	56	264
		HIGH	47.3	60	50	287	53.5	60	58	299	49.5	60	53	289	55.7	60	60	301
		ULTRA HIGH	51.3	60	54	307	57.5	70	61	319	53.5	60	57	309	59.7	70	64	321
	575-3-60	STD	31.8	40	34	182	36.6	45	39	190	33.5	40	36	184	38.3	45	41	192
		MED	34.5	40	37	194	39.3	45	42	202	36.2	45	39	196	41.0	50	44	204
		HIGH	36.2	45	39	221	41.0	50	44	229	37.9	45	41	223	42.7	50	46	231
		ULTRA HIGH	40.5	50	43	232	45.3	50	48	240	42.2	50	45	234	47.0	60	50	242

See Legend and Notes on page 65

ELECTRICAL INFORMATION (cont.)

Table 46 (cont.) - UNIT WIRE/FUSE OR HACR BREAKER SIZING DATA

48LC UNIT	NOM. V-Ph-Hz	IFM TYPE	NO C.O. or UNPWR C.O.						w/ PWRD C.O.							
			NO PE.			w/ PE. (pwrd fr/ unit)			NO PE.			w/ PE. (pwrd fr/ unit)				
			MCA	MAX FUSE or HACR BRKR	DISC. SIZE FLA LRA	MCA	MAX FUSE or HACR BRKR	DISC. SIZE FLA LRA	MCA	MAX FUSE or HACR BRKR	DISC. SIZE FLA LRA	MCA	MAX FUSE or HACR BRKR	DISC. SIZE FLA LRA		
24	208/ 230-3-60	STD	101.9	125	108	538	113.7	125	121	558	125	113	118.5	150	127	563
		MED	108.7	125	115	612	120.5	150	129	632	125	121	125.3	150	135	637
		HIGH	119.0	150	126	652	130.8	150	140	672	150	132	135.6	150	145	677
	460-3-60	STD	56.6	70	60	278	62.8	80	67	290	70	62	65.0	80	70	292
		MED	60.6	70	65	315	66.8	80	72	327	80	67	69.0	80	74	329
		HIGH	63.8	80	68	335	70.0	80	75	347	80	71	72.2	90	78	349
	575-3-60	STD	45.0	50	48	206	49.8	60	54	214	50	50	51.5	60	56	216
		MED	46.7	50	50	233	51.5	60	56	241	60	52	53.2	60	58	243
		HIGH	50.4	60	54	244	55.2	60	60	252	60	56	56.9	70	62	254
26	208/ 230-3-60	STD	124.9	175	129	629	136.7	175	142	649	175	134	141.5	175	148	654
		MED	131.7	175	137	703	143.5	175	150	723	175	142	148.3	175	156	728
		HIGH	141.0	175	147	743	152.8	200	161	763	175	153	157.6	200	167	768
	460-3-60	STD	64.9	80	68	322	71.1	90	75	334	90	70	73.3	90	78	336
		MED	68.9	90	73	359	75.1	90	80	371	90	75	77.3	100	82	373
		HIGH	72.1	90	76	379	78.3	100	83	391	90	79	80.5	100	86	393
	575-3-60	STD	53.9	60	56	235	58.7	70	62	243	70	58	60.4	80	64	245
		MED	55.6	70	58	262	60.4	80	64	270	70	60	62.1	80	66	272
		HIGH	59.3	70	62	273	64.1	80	68	281	80	64	65.8	80	70	283

See Legend and Notes on page 65

ELECTRICAL INFORMATION (cont.)

Table 47 – UNIT WIRE SIZING DATA WITH FACTORY-INSTALLED HACR BREAKER

48LC UNIT	NOM. V-Ph-Hz	IFM TYPE	NO C.O. or UNPWR C.O.						w/ PWRD C.O.										
			NO PE.			w/ PE. (pwrd fr/ unit)			NO PE.			w/ PWRD C.O.							
			MCA	HACR BRKR	DISC. SIZE FLA LRA	MCA	HACR BRKR	DISC. SIZE FLA LRA	MCA	HACR BRKR	DISC. SIZE FLA LRA	MCA	HACR BRKR	DISC. SIZE FLA LRA					
14	208/ 230-3-60	STD	59.1/59.1	80/80	61/60	343	70.9/70.9	90/90	75/74	363	63.9/63.9	80/80	67/66	348	75.7/75.7	90/90	80/79	368	
		MED	64.1/64.1	80/80	67/66	378	75.9/75.9	90/90	81/80	398	68.9/68.9	90/90	73/72	383	80.7/80.7	100/100	86/85	403	
		HIGH	71.7	90	76	382	83.5	100	89	402	76.5	90	81	387	88.3	100	95	407	
		ULTRA HIGH	79.7	100	84	456	91.5	100	97	476	84.5	100	89	461	96.3	110	103	481	
	460-3-60	STD	31.3	40	33	167	37.5	45	40	179	33.5	40	35	169	39.7	50	42	181	
		MED	33.9	45	36	184	40.1	50	43	196	36.1	45	38	186	42.3	50	45	198	
		HIGH	37.2	45	40	186	43.4	50	47	198	39.4	50	42	188	45.6	50	49	200	
		ULTRA HIGH	41.8	50	44	223	48.0	60	51	235	44.0	50	47	225	50.2	60	54	237	
	17	575-3-60	STD	24.4	30	26	119	29.2	35	31	127	26.1	30	28	121	30.9	35	33	129
			MED	26.1	30	28	133	30.9	35	33	141	27.8	30	30	135	32.6	40	35	143
HIGH			27.1	30	29	131	31.9	35	34	139	28.8	35	31	133	33.6	40	36	141	
ULTRA HIGH			29.0	35	31	158	33.8	40	36	166	30.7	35	33	160	35.5	40	38	168	
208/ 230-3-60		STD	67.4/67.4	90/90	70/69	371	79.2/79.2	100/100	83/82	391	72.2/72.2	90/90	75/74	376	84.0/84.0	100/100	89/88	396	
		MED	80.0	100	84	410	91.8	100	98	430	84.8	100	90	415	96.6	110	103	435	
		HIGH	86.9	100	92	484	98.7	125	105	504	91.7	100	97	489	103.5	125	111	509	
		ULTRA HIGH	98.5	125	103	524	110.3	125	116	544	103.3	125	108	529	115.1	150	122	549	
		STD	34.8	45	36	193	41.0	50	43	205	37.0	45	39	195	43.2	50	46	207	
		MED	40.7	50	43	212	46.9	60	50	224	42.9	50	46	214	49.1	60	53	226	
20	460-3-60	HIGH	44.9	50	48	249	51.1	60	55	261	47.1	60	50	251	53.3	60	57	263	
		ULTRA HIGH	48.9	60	51	269	55.1	60	59	281	51.1	60	54	271	57.3	70	61	283	
		STD	30.0	40	32	154	34.8	40	37	162	31.7	40	33	156	36.5	45	39	164	
		MED	32.7	40	35	166	37.5	45	40	174	34.4	40	37	168	39.2	45	42	176	
	208/ 230-3-60	HIGH	34.4	40	37	193	39.2	45	42	201	36.1	45	39	195	40.9	50	44	203	
		ULTRA HIGH	38.7	50	41	204	43.5	50	46	212	40.4	50	43	206	45.2	50	48	214	
		STD	73.3/73.3	100/100	76/75	412	85.1/85.1	100/100	90/89	432	78.1/78.1	100/100	82/81	417	89.9/89.9	100/100	95/95	437	
		MED	85.9	100	91	451	97.7	125	104	471	90.7	100	96	456	102.5	125	110	476	
		HIGH	92.8	100	99	525	104.6	125	112	545	97.6	125	104	530	109.4	125	118	550	
		ULTRA HIGH	104.4	125	109	565	116.2	150	123	585	109.2	125	115	570	121.0	150	128	590	
460-3-60	STD	37.2	50	39	231	43.4	50	46	243	39.4	50	42	233	45.6	50	49	245		
	MED	43.1	50	46	250	49.3	60	53	262	45.3	50	48	252	51.5	60	56	264		
	HIGH	47.3	60	50	287	53.5	60	58	299	49.5	60	53	289	55.7	60	60	301		
	ULTRA HIGH	51.3	60	54	307	57.5	70	61	319	53.5	60	57	309	59.7	70	64	321		
575-3-60	STD	31.8	40	34	182	36.6	45	39	190	33.5	40	36	184	38.3	45	41	192		
	MED	34.5	40	37	194	39.3	45	42	202	36.2	45	39	196	41.0	50	44	204		
	HIGH	36.2	45	39	221	41.0	50	44	229	37.9	45	41	223	42.7	50	46	231		
	ULTRA HIGH	40.5	50	43	232	45.3	50	48	240	42.2	50	45	234	47.0	60	50	242		

See Legend and Notes on page 65

ELECTRICAL INFORMATION (cont.)

Table 47 (cont.) - UNIT WIRE SIZING DATA WITH FACTORY-INSTALLED HACR BREAKER

48LC UNIT	NOM. V-Ph-Hz	IFM TYPE	NO C.O. or UNPWR C.O.						w/ PWRD C.O.									
			NO PE.			w/ PE. (pwrd fr/ unit)			NO PE.			w/ PE. (pwrd fr/ unit)						
			MCA	HACR BRKR	DISC. SIZE FLA LRA	MCA	HACR BRKR	DISC. SIZE FLA LRA	MCA	HACR BRKR	DISC. SIZE FLA LRA	MCA	HACR BRKR	DISC. SIZE FLA LRA				
24	208/ 230-3-60	STD	101.9	125	108	538	113.7	125	121	558	106.7	125	113	543	118.5	150	127	563
		MED	108.7	125	115	612	120.5	150	129	632	113.5	150	121	617	125.3	150	135	637
		HIGH	119.0	150	126	652	130.8	150	140	672	123.8	150	132	657	135.6	150	145	677
	460-3-60	STD	56.6	70	60	278	62.8	80	67	290	58.8	80	62	280	65.0	80	70	292
		MED	60.6	70	65	315	66.8	80	72	327	62.8	80	67	317	69.0	80	74	329
		HIGH	63.8	80	68	335	70.0	80	75	347	66.0	80	71	337	72.2	90	78	349
575-3-60	STD	45.0	50	48	206	49.8	60	54	214	46.7	60	50	208	51.5	60	56	216	
	MED	46.7	50	50	233	51.5	60	56	241	48.4	60	52	235	53.2	60	58	243	
	HIGH	50.4	60	54	244	55.2	60	60	252	52.1	60	56	246	56.9	70	62	254	
26	208/ 230-3-60	STD	124.9	175	129	629	136.7	175	142	649	129.7	175	134	634	141.5	175	148	654
		MED	131.7	175	137	703	143.5	175	150	723	136.5	175	142	708	148.3	175	156	728
		HIGH	141.0	175	147	743	152.8	200	161	763	145.8	175	153	748	157.6	200	167	768
	460-3-60	STD	64.9	80	68	322	71.1	90	75	334	67.1	90	70	324	73.3	90	78	336
		MED	68.9	90	73	359	75.1	90	80	371	71.1	90	75	361	77.3	100	82	373
		HIGH	72.1	90	76	379	78.3	100	83	391	74.3	90	79	381	80.5	100	86	393
575-3-60	STD	53.9	60	56	235	58.7	70	62	243	55.6	70	58	237	60.4	80	64	245	
	MED	55.6	70	58	262	60.4	80	64	270	57.3	70	60	264	62.1	80	66	272	
	HIGH	59.3	70	62	273	64.1	80	68	281	61.0	80	64	275	65.8	80	70	283	

Example: Supply voltage is 230-3-60



AB = 224 V
BC = 231 V
AC = 226 V

$$\text{Average Voltage} = \frac{(224 + 231 + 226)}{3} = \frac{681}{3} = 227$$

Determine maximum deviation from average voltage.

$$(AB) 227 - 224 = 3 \text{ v}$$

$$(BC) 231 - 227 = 4 \text{ v}$$

$$(AC) 227 - 226 = 1 \text{ v}$$

Maximum deviation is 4 v.

Determine percent of voltage imbalance.

$$\% \text{ Voltage Imbalance} = 100 \times \frac{4}{227}$$

$$= 1.76\%$$

This amount of phase imbalance is satisfactory as it is below the maximum allowable 2%.

IMPORTANT: If the supply voltage phase imbalance is more than 2%, contact your local electric utility company immediately.

LEGEND:

- BRKR - Circuit breaker
- C.O. - Convenience outlet
- DISC - Disconnect
- FLA - Full load amps
- IFM - Indoor Fan Motor
- LRA - Locked rotor amps
- MCA - Minimum circuit amps
- PE - Power exhaust
- pwrd fr/unit - Powered from unit
- PWRD C.O. - Powered convenience outlet
- UNPWR C.O. - Unpowered convenience outlet

NOTES:

1. In compliance with NEC requirements for multimotor and combination load equipment (refer to NEC Articles 430 and 440), the overcurrent protective device for the unit shall be fuse or HACR breaker. Canadian units may be fuse or circuit breaker.
2. For 208/230 v units, where one value is shown it is the same for either 208 or 230 volts.
3. **Unbalanced 3-Phase Supply Voltage**
Never operate a motor where a phase imbalance in supply voltage is greater than 2%. Use the following formula to determine the percentage of voltage imbalance.

$$\% \text{ Voltage Imbalance} = 100 \times \frac{\text{max voltage deviation from average voltage}}{\text{average voltage}}$$

TYPICAL WIRING DIAGRAMS

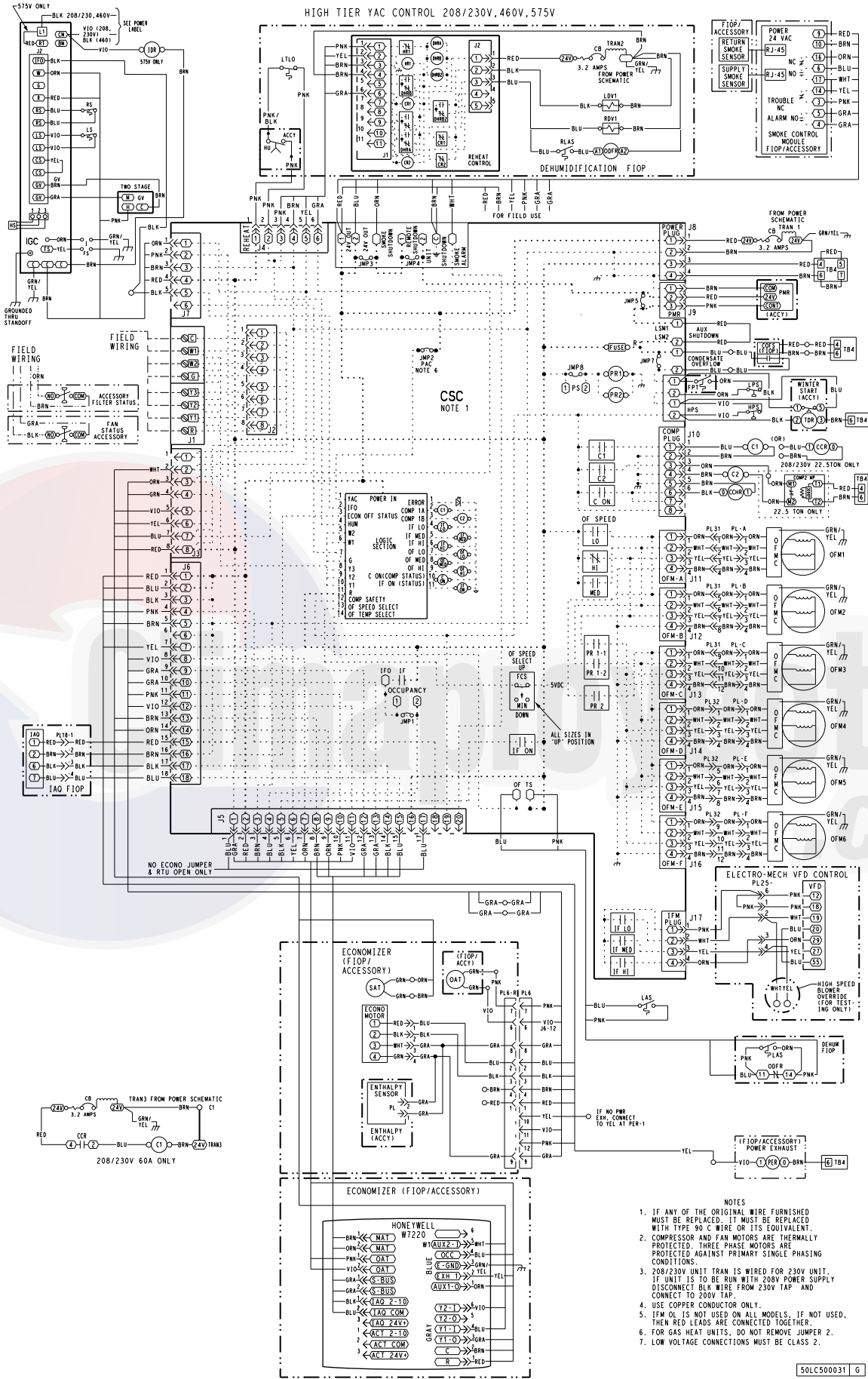
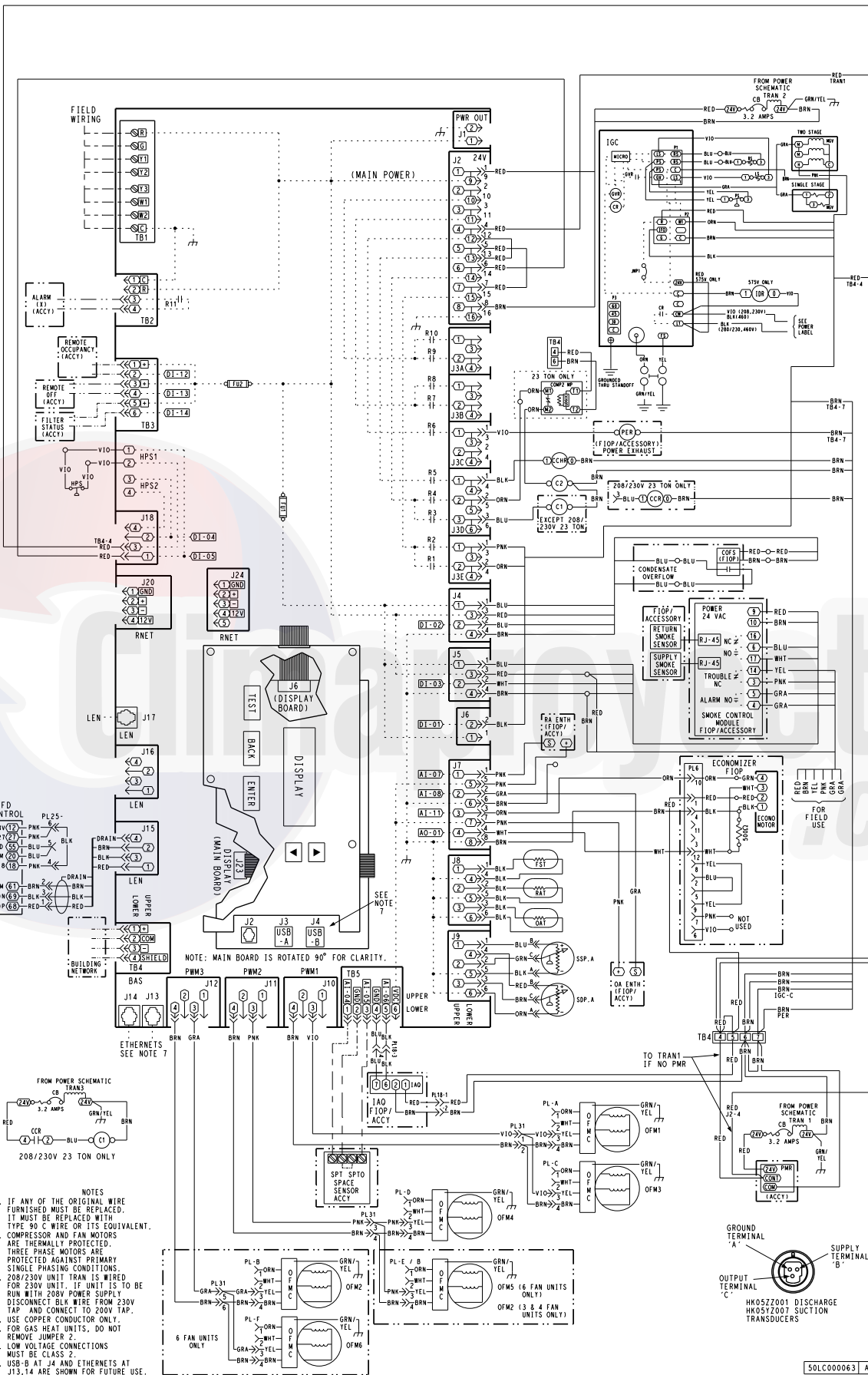

Fig. 16 - Typical Electromechanical Control Wiring Diagram 48LC 14-26

TYPICAL WIRING DIAGRAMS (cont.)

HIGH TIER YAC PIC CONTROL 208/230V, 460V, 575V



C160066

TYPICAL WIRING DIAGRAMS (cont.)

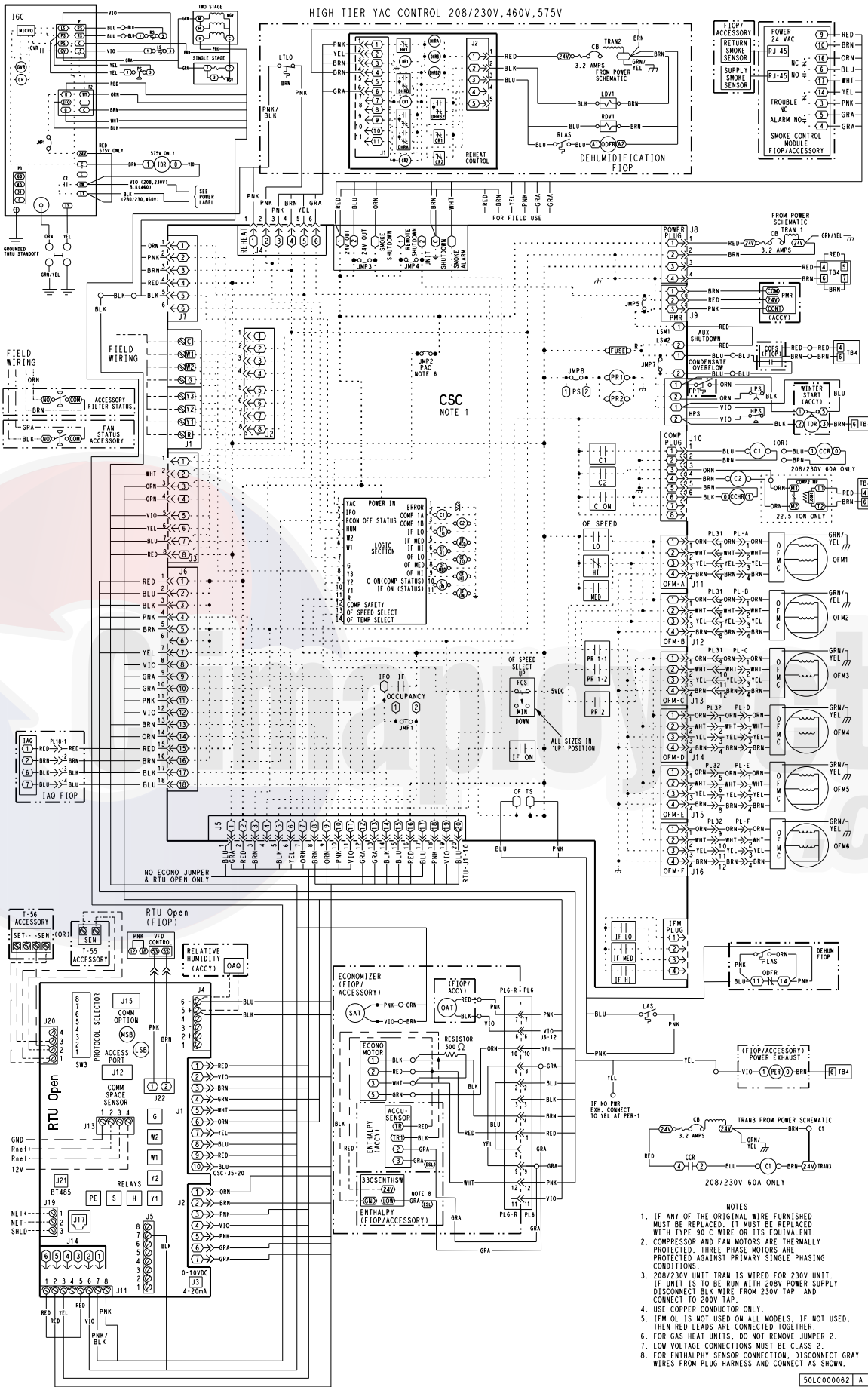

Fig. 18 - 48LC 14-26 RTU Open Control Wiring Diagram

C160067

TYPICAL WIRING DIAGRAMS (cont.)

12.5 - 20 TON YAC, PAC POWER 208/230V 3 PH WITH/WITHOUT HOT GAS REHEAT FIOF

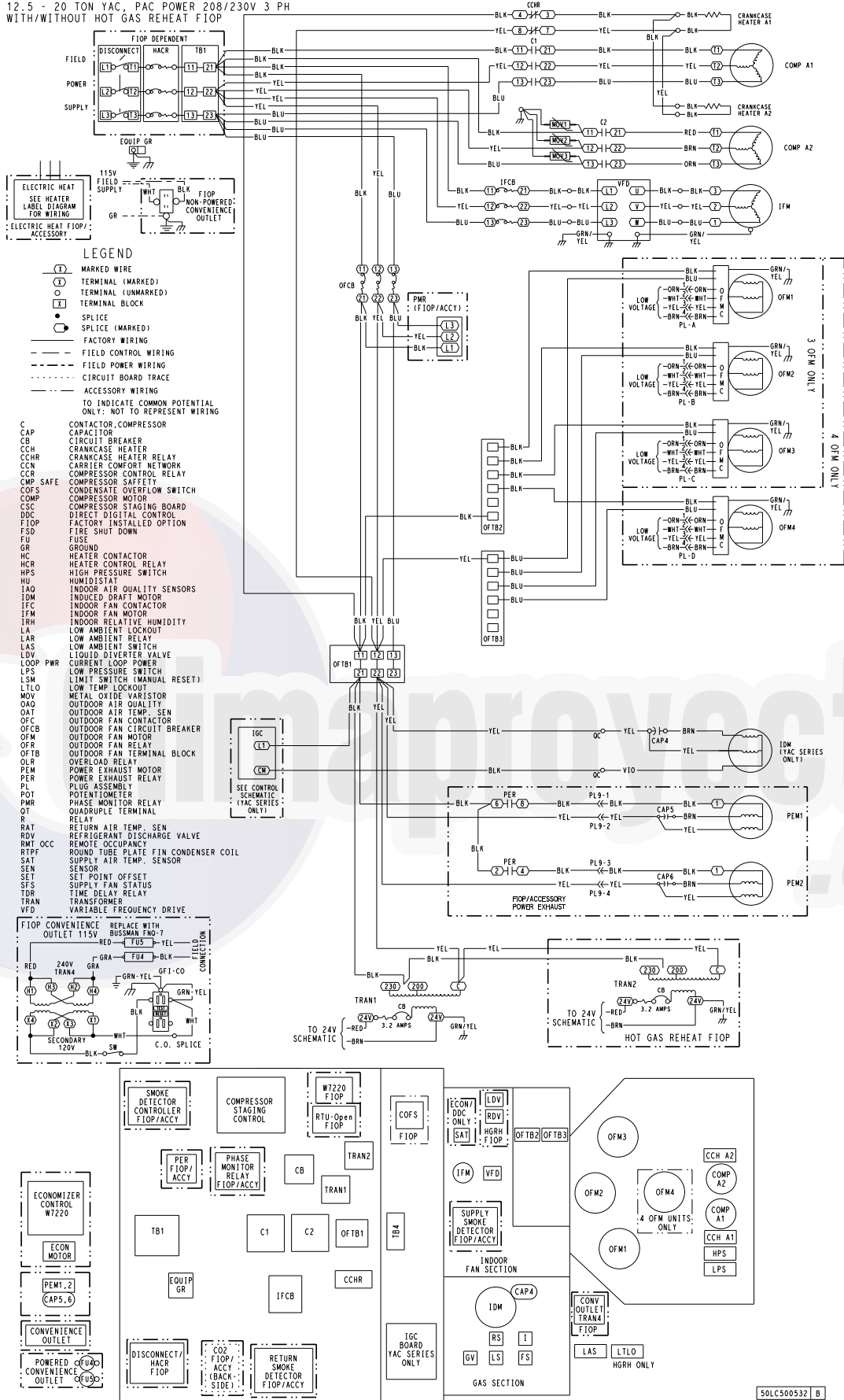

Fig. 19 - Typical Power Wiring Diagram, 48LC 14-20 208/230V shown

NOTE: Power Wiring Diagram is typical for electromechanical, SystemVu™ and RTU Open units.

TYPICAL SEQUENCE OF OPERATION

General

The Carrier Integrated Staging Control Board (ISC) is intended for use with a standard thermostat capable of three cooling stages. After initial power to the board, a Green LED will blink with a 1 second duty cycle indicating the unit is running properly. When the unit is not running properly, the Green LED will blink along with Red LED lights. The Red LED light configuration will indicate the type of error the board has identified.

The ISC board can be remotely shutdown by removing Jumper 4 and wiring to the Remote Shutdown terminal. The Smoke Control Module can shutdown the unit by removing Jumper 3 and wiring to the Smoke Shutdown terminal. A smoke alarm can be obtained by wiring to the Smoke Alarm terminal.

The crankcase heater will run at all times except when the compressors are running. An auxiliary power supply (24Vac) available at TB-4 Terminal is provided to power auxiliary equipment. An optional Phase Monitor Relay can be wired to the PMR terminal by removing Jumper 5.

Ventilation

In the Ventilation/Fan Mode (G on the thermostat), the indoor fan will run at low speed and the damper will operate at minimum position.

Cooling

In the Cooling Mode, the small and large compressors will be sequenced to maintain the thermostat/DDC temperature setpoint. Table 48 shows the cooling operation based on the following conditions.

The outdoor fan and VFD controlled indoor-fan will operate at low, medium and high speed. The indoor-fan speed (rpm) is factory set by the CFM and static pressure requirements for the unit installed.

Humidi-MiZer® (Optional)

In the Dehumidification Mode, both compressors will run and Indoor airflow will rise to High Speed.

In subcooling mode (reheat-1), during part load conditions when the room temperature and humidity are above the set point, the unit initiates the sub-cooling mode of operation; a call for cooling and dehumidification. RDV (Reheat Discharge Valve) and TWV (Three Way Valve) close; Indoor and Outdoor airflow will rise until reaching 100% of Speed.

In hot gas reheat mode (reheat-2), when there is a call for dehumidification without a call for cooling, a portion of the hot gas from the compressor bypasses the condenser coil when RDV opens and hot gas is fed into the liquid line, TWV closes in this mode and the system provides mainly latent cooling. Indoor airflow will rise until reaching 100% of Speed, Outdoor airflow will run at High speed as long as outdoor temperature is above 80°F (26.7°C); when operating in this mode below 80°F (26.7°C) OAT, the system outdoor fan will operate as shown in the table below based on size:

LC Size	RPM	Number of Fans On	Number of Fans Off
14	250	3	0
17	250	4	0
20	160	4	0
24	250	6	0
26	250	6	0

Table 48 – COOLING OPERATION

INPUT	OUTPUT			
	Compressor C1	Compressor C2	Indoor Fan Speed	Outdoor Fan Speed
Thermostat				
First Stage Cooling (Y1)	On	Off	Low	Low (700 rpm)
Second Stage Cooling (Y2)	Off	On	Medium	Medium (800 rpm)
Third Stage Cooling (Y3)	On	On	High	High (1,000 rpm)

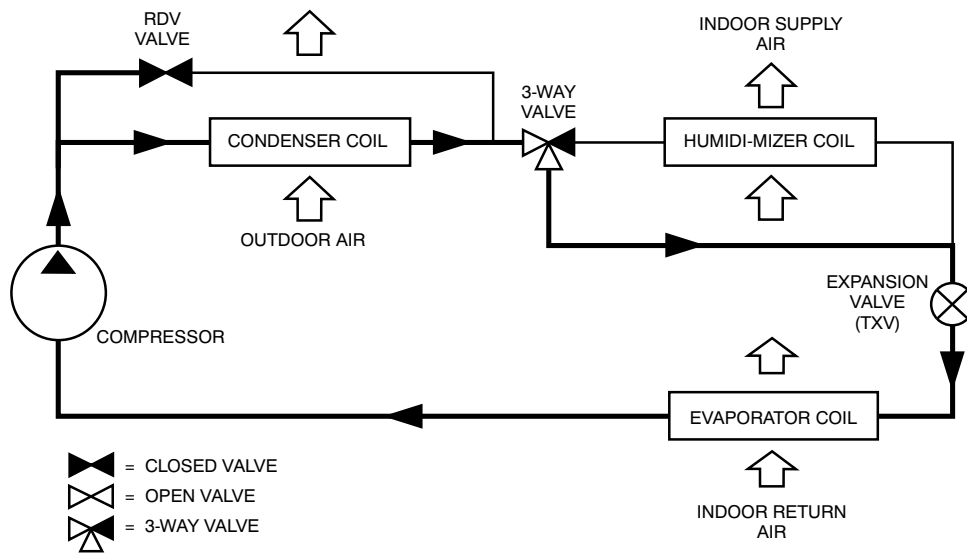

Fig. 20 - Humidi-MiZer® Piping Schematic Normal Cooling

C14114

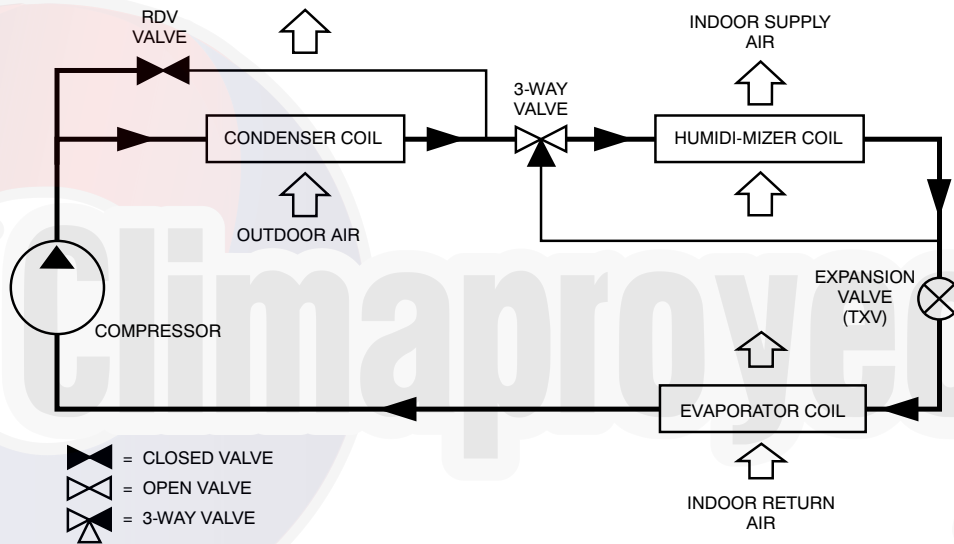

Fig. 21 - Humidi-MiZer Piping Schematic Subcooling Mode (Reheat1)

C14115

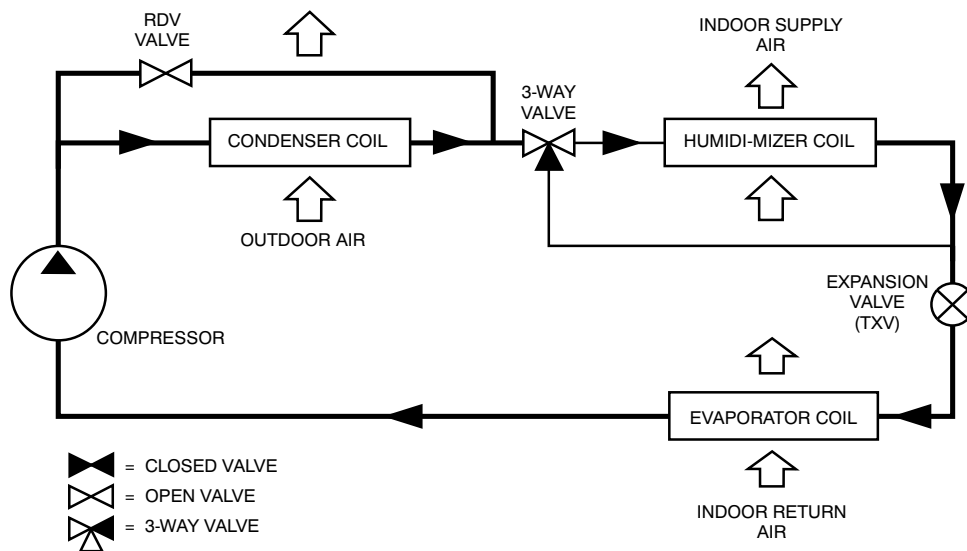

Fig. 22 - Humidi-MiZer Piping Schematic Hot Gas Reheat Mode (Reheat 2)

C14116

Economizer (Optional)

When the Economizer DDC is in Free Cooling Mode and a demand for cooling exist (Y1 on the thermostat), the Economizer DDC will modulate the outdoor-air damper to provide a 50°F (10°C) to 55°F (13°C) mixed-air temperature into the zone and run the indoor-fan at high speed. As mixed-air temperature fluctuates above 55°F (13°C) or below 50°F (10°C) dampers will be modulated (open or close) to bring the mixed-air temperature back within control. Upon more call for cooling (Y2 on the thermostat), the outdoor-air damper will maintain its current position, compressor C1 will run and the outdoor-fan will run at low speed. If there is further demand for cooling, the outdoor-air damper will maintain its current position, only compressor C2 will run and the outdoor fan will run at medium speed. The VFD controlled indoor fan will operate at high speed regardless of the cooling demand.

If the increase in cooling capacity causes the mixed-air temperature to drop below 45°F, the outdoor-air damper will return to the minimum position. If the mixed-air temperature continues to fall, the outdoor-air damper will close. Control returns to normal once the mixed air temperature rises above 48°F (9°C). The power exhaust fans will be energized and de-energized, if installed, as the outdoor-air damper opens and closes.

In field-installed accessory CO₂ sensors are connected to the Economizer DDC, a demand controlled ventilation strategy will begin to operate. As the CO₂ level in the zone increases above the CO₂ setpoint, the minimum position of the damper will be increased proportionally. As the CO₂ level decreases because of the increase of fresh air, the outdoor-air damper will be proportionally closed. For economizer operation, there must be a thermostat call for the fan (G). If the unit is occupied and the fan is on, the damper will operate at minimum position. Otherwise, the damper will be closed.

Low Ambient

In Low Ambient RTU conditions when the temperature is less than 55°F (13°C), the Low Ambient Switch (LAS) will be active and the outdoor-fans will run to the pre-set factory outdoor-fan speed. When the temperature is greater than 65°F (18°C), the Low Ambient Switch will deactivate and the outdoor-fans will run in the standard cooling mode. If the Outdoor Fan Select Switch is in the up position, the outdoor fans will run in the Fan Cycle

Speed Mode (FCS) set to 250 rpm. If the Outdoor Fan Select Switch is in the down position, the outdoor fans will run in the Minimum Fan Speed Mode (MIN) set to 160 rpm regardless of the cooling demand.

LC Size 14 through 26 units have a SPST normally open Low Ambient Switch wired across the TS and OF terminal and a jumper placed across the PS terminal (See Fig. 24). When the LAS is active, the switch will close making contact to the OF terminal. This is done for units that require all outdoor fans to run at the same pre-set factory Low Ambient Speed.

The Low Ambient Outdoor Fan Control chart (below) shows the operation of the outdoor fans for each unit

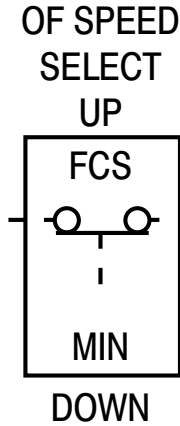

Fig. 23 - Outdoor Fan Speed Select Switch

C13327

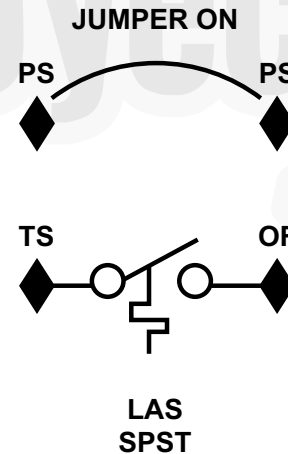

Fig. 24 - Schematic of SPST and SPDT Low Ambient Switch

C13328

Table 49 – LOW AMBIENT TEMPERATURE OUTDOOR FAN CONTROL

LC Size	No. of Fans On	No. of Fans Off	Switch	Low Ambient Switch Fig. No.	Outdoor Fan Select Switch	RPM
14	3	0	(1) SPST	24	Up	250
17	4	0	(1) SPST	24	Up	250
20	4	0	(1) SPST	24	Up	160
24	6	0	(1) SPST	24	Up	250
26	6	0	(1) SPST	24	Up	250

Heating

In the Heating Mode (W1 on the thermostat), the ISC board sends power to W on the IGC board. The ISC board sees W1=ON and also expects IFO=ON. However, the IFO is not ON immediately as the Integrated Gas Controller (IGC) board has to work thru its operating sequence. Thus, the ISC board will turn on a momentary LED (light-emitting diode). The indoor fan is not turned on by the ISC board.

The IGC board starts its gas ignition process. An LED on the IGC board turns on and remains on during normal operation. A check is made to ensure that the rollout switch and limit switch are closed. If the check was successful, the induced draft motor is energized, and when its speed is satisfactory, as proven by the flue gas pressure switch, the ignition activation period begins. The burners will ignite within 5 seconds. If the burners do not light, there is a 22-second delay before another 5 second attempt. This sequence is repeated for 15 minutes or until the burners light. If, after the 15 minutes, the burners still have not lit, heating is locked out. To reset the control, break 24VAC power to the thermostat.

When gas ignition occurs, the IGC board will continue to monitor the condition of the rollout switch, the limit switches, the flue gas pressure switch, as well as the flame sensor. Once gas ignition is confirmed, the IGC board has a 45 second built in delay before it sends an IFO=ON signal to the ISC board. Assuming the unit is controlled through a room thermostat set for fan auto, the indoor-fan motor will energize and the outdoor-air dampers will open to their minimum position. The delay will allow for the gas section to come to temperature before turning on the indoor fan. This will prevent the unit from blowing cold air into the space. Once the ISC board sees IFO=ON, the VFD controlled indoor fan is set to high speed and the LED error is cleared. If, for some reason the over temperature limit opens prior to the start of the indoor fan blower, the unit will shorten the 45 second delay to 5 seconds less than the time from initiation of heat to when the limit tripped. Gas will not be interrupted to the burners and heating will continue. Once the fan ON delay has been modified, it will not change back to 45 seconds until power is reset to the control.

When W1 is turned OFF, the IGC board turns off the gas valve. The IGC board has a delay time before it turns IFO=OFF. At this time, the ISC board sees W1=OFF and IFO=ON. The ISC will keep the indoor fan ON. Once the IGC board delay times out, the ISC board will see W1=OFF and IFO=OFF, which then turns the indoor fan OFF.

If the call for W1 lasted less than 1 minute, the heating cycle will not terminate until 1 minute after W1 became active. If the unit is controlled through a room thermostat set for fan auto, the indoor fan motor will continue to operate for an additional 45 seconds then stop. If the over temperature limit opens after the indoor motor is stopped, but within 10 minutes of W1 becoming inactive, on the next cycle the time will be extended by 15 seconds. The maximum delay is 3 minutes. Once modified, the fan OFF delay will not change back to 45 seconds unless power is reset to the control. A LED indicator is provided on the IGC to monitor operation.

When additional heat is required, W2 closes and initiates power to the second stage of the main gas valve. When the thermostat is satisfied, the gas valve closes, interrupting the flow of gas to the main burners.

SystemVu™ Control (Factory Option)

For details on operating 48LC units equipped with the factory installed SystemVu controls option refer to *48/50LC 07-26 Single Package Rooftop Units with SystemVu™ Controls Version 1.X and PURON® (R-410A) Refrigerant Controls, Start-Up, Operation and Troubleshooting* (Catalog No.: S-VU-LC-7-26-02T or later).

RTU Open (Factory Option)

For details on operating 48LC units equipped with the factory installed RTU Open option refer to *48/50LC-07-26 Factory Installed Option RTU Open Multi-Protocol Controller Controls, Start-Up, Operation and Troubleshooting* (Catalog No.: 48-50LC-7-26-2T, or later).

GUIDE SPECIFICATIONS – 48LC**14-26

Note about this specification:

This specification is in the “Masterformat” as published by the Construction Specification Institute. Please feel free to copy this specification directly into your building spec.

WeatherExpert® Ultra High-Efficiency Gas Heat/Electric Cooling Packaged Rooftop



HVAC Guide Specifications:

Size Range: 12.5 to 23 Nominal Tons

<u>Section</u>	<u>Description</u>
----------------	--------------------

23 06 80	Schedules for Decentralized HVAC Equipment
-----------------	---

- | | |
|----------------|---|
| 23 06 80.13 | Decentralized Unitary HVAC Equipment Schedule |
| 23 06 80.13.A. | Rooftop unit schedule |
| 1. | Schedule is per the project specification requirements. |

23 07 16	HVAC Equipment Insulation
-----------------	----------------------------------

- | | |
|----------------|--|
| 23 07 16.13 | Decentralized, Rooftop Units: |
| 23 07 16.13.A. | Evaporator fan compartment: |
| 1. | Interior cabinet surfaces shall be insulated with a minimum 1/2-in. thick, minimum 1 1/2 lb density aluminum foil-faced insulation on the air side. |
| 2. | Insulation and adhesive shall meet NFPA 90A requirements for flame spread and smoke generation. |
| 3. | Unit internal insulation linings shall be resistant to mold growth in accordance with “mold growth and humidity” test in ASTM C1338, G21, and UL 181 or comparable test method. Air stream surfaces shall be evaluated in accordance with the “Erosion Test” in UL 181, as part of ASTM C1071. |
| 23 07 16.13.B. | Gas heat compartment: |
| 1. | Aluminum foil-faced fiberglass insulation shall be used. |
| 2. | Insulation and adhesive shall meet NFPA 90A requirements for flame spread and smoke generation. |

23 09 13	Instrumentation and Control Devices for HVAC
-----------------	---

- | | |
|----------------|---|
| 23 09 13.23 | Sensors and Transmitters |
| 23 09 13.23.A. | Thermostats |
| 1. | Thermostat must |
| a. | energize both “W” and “G” when calling for heat. |
| b. | have capability to energize 3 different stages of cooling, and 2 different stages of heating. |
| c. | include capability for occupancy scheduling. |

23 09 23	Direct Digital Control (DDC) System for HVAC
-----------------	---

- | | |
|----------------|---|
| 23 09 23.13 | Decentralized, Rooftop Units: |
| 23 09 23.13.A. | SystemVu™ intelligent integrated Direct Digital Control (DDC) shall provide: |
| 1. | Integrated unit operation for comfort cooling, heating ventilation as well as all monitoring, recording and reporting capabilities. Controller shall also provide diagnostics and alarms of abnormal unit operation through the controller. Controller shall have an intuitive user display and be able to be used in a standalone operation or via building automation system (BAS). |
| 2. | Quick Unit Status LED's of: Run – meaning all systems are go, ALERT - that indicates there is currently a non-critical issue with the unit, like filters need to be replaced and FAULT – that indicates the unit has a critical issue and will possibly shut down. |
| 3. | Six large navigation keys for easy access. Navigation keys shall consist of: TEST, BACK, ENTER, and MENU along with UP and DOWN arrows. |
| 4. | Full back lit user display with 4 line by 30 character text capabilities. Display menu shall be designed to provide guided major menus and sub menus main menus provided below: |
| — | Shutdown Unit |

- Run Status
 - Settings
 - Alerts/Faults
 - Service
 - Inputs
 - Outputs
 - USB
5. The capability for standalone operation with conventional thermostat/sensor or use with building automation systems (BAS) of Carrier i-Vu[®], BACnet* and Carrier Comfort Network[®] (CCN) systems. No special modules or boards are required for these capabilities.
 6. The ability to read refrigerant pressures at display or via BAS network of; Discharge Pressure and Suction Pressure. The need for traditional refrigerant gauges is not required.
 7. USB Data Port for flash drive interaction. This will allow the transfer of data for uploads, downloads, perform software upgrades, back-up and restore data and file transfer data such as component number of starts and run hours.
 8. Reverse Rotation Protection of compressors if field three phase wiring is misapplied.
 9. Provide Service Capabilities of:
 - Auto run test
 - Manual run test
 - Component run hours and starts
 - Commissioning reports
 - Data logging
 - Alarm history
 10. Economizer control and diagnostics. Set up economizer operation, receive feedback from actuator. Also meets the most recent California Title 24 Fault Detection and Diagnostic (FDD) requirements.
 11. Unit cooling operation down to 0°F (-18°C)
 12. Controller shall have easy access connections around the controller perimeter area and consist of Mate-N-Lok, terminal block and RJ style modular jack connections.
 13. 365 day real time clock, 20 holiday schedules along with occupied and unoccupied scheduling.
 14. Auto-Recognition for easy installation and commissioning of devices like economizers, space sensors etc.
 15. A 5°F temperature difference between cooling and heating set points to meet the latest ASHRAE 90.1-2013 Energy Standard.
 16. Contain return air sensor, supply air sensor and outdoor air sensor to help monitor and provide data for the unit comfort operation, diagnostic and alarms.
 17. Use of Carrier's field accessory hand-held Navigator™ display.
 18. Control of the operation of unit VFD (Variable Frequency Drive) to work in conjunction with the cooling, heating and ventilation modes.
 19. 3-year limited part warranty
- 23.09.23.13.B. RTU Open - multi-protocol, direct digital controller:
1. Shall be ASHRAE 62 compliant.
 2. Shall accept 18-30VAC, 50-60Hz, and consume 15VA or less power.
 3. Shall have an operating temperature range from -40°F (-40°C) to 130°F (54°C), 10% - 90% RH (non-condensing).
 4. Shall include built-in protocol for BACnet (MS/TP and PTP modes), Modbus[†] (RTU and ASCII), Johnson N2 and LonWorks^{**}. LonWorks Echelon processor required for all Lon applications shall be contained in separate communication board.
 5. Shall allow access of up to 62 network variables (SNVT). Shall be compatible with all open controllers
 6. Baud rate Controller shall be selectable using a dipswitch.
 7. Shall have an LED display independently showing the status of serial communication, running, errors, power, all digital outputs, and all analog inputs.
 8. Shall accept the following inputs: space temperature, setpoint adjustment, outdoor air temperature, indoor air quality, outdoor air quality, compressor lock-out, fire shutdown, enthalpy switch, and fan status/filter status/humidity/ remote occupancy.
 9. Shall provide the following outputs: economizer, fan, cooling stage 1, cooling stage 2, heat stage 1, heat stage 2, heat stage 3/ exhaust/ reversing valve.

* BACnet is a registered trademark of ASHRAE (American Society of Heating, Refrigerating and Air-Conditioning Engineers).

† Modbus is a registered trademark of Schneider Electric.

** LonWorks is a registered trademark of Echelon Corporation.

10. Shall have built-in surge protection circuitry through solid state polyswitches. Polyswitches shall be used on incoming power and network connections. Polyswitches will return to normal when the “trip” condition clears.
11. Shall have a battery back-up capable of a minimum of 10,000 hours of data and time clock retention during power outages.
12. Shall have built-in support for Carrier technician tool.
13. Shall include an RS-485 protocol communication port, an access port for connection of either a computer or a Carrier technician tool, an EIA-485 port for network communication to intelligent space sensors and displays, and a port to connect an optional LonWorks communications card.
14. Software upgrades will be accomplished by either local or remote download. No software upgrades through chip replacements are allowed.

23 09 33 Integrated Staging Control (ISC) Board System for HVAC (Electro-Mechanical units)

23 09 33.13 Decentralized, Rooftop Units:

23 09 33.13.A. General:

1. Shall be complete with self-contained low-voltage control circuit protected by a resettable circuit breaker on the 24-v transformer side. Transformer shall have 75VA capability.
2. Shall utilize color-coded wiring.
3. Shall include an ISC electro-mechanical control board, to conveniently and safely provide connection points for vital control functions such as: smoke detectors, phase monitor, gas controller, economizer, thermostat, and safety switches. Shall control all three stages of compressor logic, two or three stages of the indoor fan motor logic as well as staging of the outdoor fan motor. Shall also have a green LED indicator to indicate GO operation as well as a fault LED indicator for thermostat mis-wiring, no fan operation and safety
NOTE: Does not apply to units equipped with SystemVu™ controls.
4. The heat exchanger shall be controlled by an integrated gas controller (IGC) microprocessor. See heat exchanger section of this specification.

23 09 33.13.B. Safeties:

1. Compressor over-temperature, over-current. High internal pressure differential.
2. Low-pressure Protection.
 - a. Low-pressure switch shall use different color wire than the high-pressure switch. The purpose is to assist the installer and service technician to correctly wire and or troubleshoot the rooftop unit.
NOTE: Does not apply to units equipped with SystemVu controls.
3. High-pressure Protection.
 - a. High-pressure switch shall use different color wire than the low-pressure switch. The purpose is to assist the installer and service technician to correctly wire and or troubleshoot the rooftop unit.
4. Automatic reset, motor thermal overload protector.
5. Heating section shall be provided with the following minimum protections:
 - a. High-temperature limit switches.
 - b. Induced draft motor speed sensor.
 - c. Flame rollout switch.
 - d. Flame proving controls.

23 09 93 Sequence of Operations for HVAC Controls

23 09 93.13 Decentralized, Rooftop Units:

23 09 93.13.A. INSERT SEQUENCE OF OPERATION

23 40 13 Panel Air Filters

23 40 13.13 Decentralized, Rooftop Units:

23 40 13.13.A. Standard filter section

1. Shall consist of factory-installed, low velocity, disposable 2-in. thick fiberglass filters of commercially available sizes.
2. Unit shall use only one filter size. Multiple sizes are not acceptable.
3. Filters shall be accessible through a dedicated, weather tight access panel.
4. 4-in filter capabilities shall be capable with pre-engineered and approved Carrier filter track field-installed accessory. This kit requires field furnished filters.

23 81 19 Self-Contained Air Conditioners

23 81 19.13 Medium-Capacity Self-Contained Air Conditioners (48LC**14-26)

23 81 19.13.A. General

1. Outdoor, rooftop mounted, DDC electrically controlled, heating and cooling unit utilizing fully hermetic scroll compressors for cooling duty and gas combustion for heating duty.
2. Factory assembled, single-piece heating and cooling rooftop unit. Contained within the unit enclosure shall be all factory wiring, piping, controls, and special features required prior to field start-up.
3. Unit shall use Puron[®] (R-410A) refrigerant.
4. Unit shall be installed in accordance with the manufacturer's instructions.
5. Unit must be selected and installed in compliance with local, state, and federal codes.

23 81 19.13.B. Quality Assurance

1. Unit meets and exceeds ASHRAE 90.1-2013 minimum efficiency requirements.
2. Unit shall be rated in accordance with AHRI Standard 340/360.
3. Unit shall be designed to conform to ASHRAE 15.
4. Unit shall be ETL-tested and certified in accordance with ANSI Z21.47 Standards and ETL-listed and certified under Canadian standards as a total package for safety requirements.
5. Insulation and adhesive shall meet NFPA 90A requirements for flame spread and smoke generation.
6. Unit internal insulation linings shall be resistant to mold growth in accordance with "mold growth and humidity" test in ASTM C1338, G21, and UL 181 or comparable test method. Air stream surfaces shall be evaluated in accordance with the "Erosion Test" in UL 181, as part of ASTM C1071.
7. Unit casing shall be capable of withstanding 500-hour salt spray exposure per ASTM B117 (scribed specimen).
8. Roof curb shall be designed to conform to NRCA Standards.
9. Unit shall be subjected to a completely automated run test on the assembly line. The data for each unit will be stored at the factory, and must be available upon request.
10. Unit shall be designed in accordance with UL Standard 1995, ETL listed including tested to withstand rain.
11. Unit shall be constructed to prevent intrusion of snow and tested to prevent snow intrusion into the control box up to 40 mph.
12. Unit shake tested to assurance level 1, ASTM D4169 to ensure shipping reliability.
13. High-Efficiency Motors listed shall meet section 313 of the Energy Independence and Security Act of 2007 (EISA 2007).

23 81 19.13.C. Delivery, Storage, and Handling

1. Unit shall be stored and handled per manufacturer's recommendations.
2. Lifted by crane requires either shipping top panel or spreader bars.
3. Unit shall only be stored or positioned in the upright position.

23 81 19.13.D. Project Conditions

1. As specified in the contract.

23 81 19.13.E. Operating Characteristics

1. Unit shall be capable of starting and running at 125°F (52°C) ambient outdoor temperature, meeting maximum load criteria of AHRI Standard 340/360 at ± 10% voltage.
2. Compressor with standard controls shall be capable of operation down to 40°F (4°C), ambient outdoor temperatures. For lower operation an integrated economizer shall be utilized to allow lower temperatures and accommodate indoor air quality initiatives
3. Unit shall discharge supply air vertically or horizontally as shown on contract drawings.
4. Unit shall be factory configured and ordered for vertical supply & return configurations.
5. Unit shall be factory furnished for either vertical or horizontal configuration without the use of special conversion kits. No field conversion is possible.

23 81 19.13.F. Electrical Requirements

1. Main power supply voltage, phase, and frequency must match those required by the manufacturer.

23 81 19.13.G. Unit Cabinet

1. Unit cabinet shall be constructed of galvanized steel, and shall be bonderized and coated with a pre-painted baked enamel finish on all externally exposed surfaces.
2. Unit cabinet exterior paint shall be: film thickness, (dry) 0.003 inches minimum, gloss (per ASTM D523, 60°F / 16°C): 60, Hardness: H-2H Pencil hardness.
3. Evaporator fan compartment interior cabinet insulation shall conform to AHRI Standard 340/360 minimum exterior sweat criteria. Interior surfaces shall be insulated with a minimum 1/2-in. thick, 1 lb density, aluminum foil-faced fiberglass insulation. Aluminum foil-faced fiberglass insulation shall also be used in the gas heat compartment.
4. Unit internal insulation linings shall be resistant to mold growth in accordance with "mold growth and humidity" test in ASTM C1338, G21, and UL 181 or comparable test method. Air stream surfaces shall be evaluated in accordance with the "Erosion Test" in UL 181, as part of ASTM C1071.

5. Base of unit shall have a minimum of four locations for thru-the-base gas and electrical connections standard. Both gas and electric connections shall be internal to the cabinet to protect from environmental issues.
6. Base Rail
 - a. Unit shall have base rails on a minimum of 2 sides.
 - b. Holes shall be provided in the base rails for rigging shackles to facilitate maneuvering and overhead rigging.
 - c. Holes shall be provided in the base rail for moving the rooftop by fork truck.
 - d. Base rail shall be a minimum of 16 gauge thickness.
7. Condensate pan and connections:
 - a. Shall be a sloped condensate drain pan made of a non-corrosive material.
 - b. Shall comply with ASHRAE Standard 62.
 - c. Shall use a 3/4-in -14 NPT drain connection, through the side of the drain pan. Connection shall be made per manufacturer's recommendations.
8. Top panel:
 - a. Shall be a multi-piece top panel linked with water tight flanges and locking systems.
9. Gas Connections:
 - a. All gas piping connecting to unit gas valve shall enter the unit cabinet at a single location on side of unit (horizontal plane).
 - b. Thru-the-base capability
 - (1.) Standard unit shall have a thru-the-base gas-line location using a raised, embossed portion of the unit basepan.
 - (2.) Thru-the-base provisions/connections are available as standard with every unit. When bottom connections are required, field furnished couplings are required.
 - (3.) No basepan penetration, other than those authorized by the manufacturer, is permitted.
10. Electrical Connections
 - a. All unit power wiring shall enter unit cabinet at a single, factory-prepared, knockout location.
 - b. Thru-the-base capability.
 - (1.) Thru-the-base provisions/connections are available as standard with every unit. When bottom connections are required, field furnished couplings are required.
 - (2.) No basepan penetration, other than those authorized by the manufacturer, is permitted.
11. Component access panels (standard)
 - a. Cabinet panels shall be easily removable for servicing.
 - b. Unit shall have one factory installed, tool-less, removable, filter access panel.
 - c. Panels covering control box and filter shall have molded composite handles while the blower access door shall have an integrated flange for easy removal.
 - d. Handles shall be UV modified, composite, permanently attached, and recessed into the panel.
 - e. Screws on the vertical portion of all removable access panel shall engage into heat resistant, molded composite collars.
 - f. Collars shall be removable and easily replaceable using manufacturer recommended parts.

23 81 19.13.H. Gas Heat

1. General
 - a. Heat exchanger shall be an induced draft design. Positive pressure heat exchanger designs shall not be allowed.
 - b. Shall incorporate a direct-spark ignition system and redundant main gas valve.
 - c. Gas supply pressure at the inlet to the rooftop unit gas valve must match that required by the manufacturer.
2. The heat exchanger shall be controlled by an integrated gas controller (IGC) microprocessor.
 - a. IGC board shall notify users of fault using an LED (light-emitting diode).
 - b. The LED shall be visible without removing the control box access panel.
 - c. IGC board shall contain algorithms that modify evaporator-fan operation to prevent future cycling on high temperature limit switch.
 - d. Unit shall be equipped with anti-cycle protection with one short cycle on unit flame rollout switch or 4 continuous short cycles on the high temperature limit switch. Fault indication shall be made using an LED.
3. Standard Heat Exchanger construction
 - a. Heat exchanger shall be of the tubular-section type constructed of a minimum of 20-gauge steel coated with a nominal 1.2 mil aluminum-silicone alloy for corrosion resistance.
 - b. Burners shall be of the in-shot type constructed of aluminum-coated steel.

- c. Burners shall incorporate orifices for rated heat output up to 2000 ft (610 m) elevation. Additional accessory kits may be required for applications above 2000 ft (610 m) elevation, depending on local gas supply conditions.
 - d. Each heat exchanger tube shall contain multiple dimples for increased heating effectiveness.
4. Optional Stainless Steel Heat Exchanger construction
 - a. Use energy saving, direct-spark ignition system.
 - b. Use a redundant main gas valve.
 - c. Burners shall be of the in-shot type constructed of aluminum-coated steel.
 - d. All gas piping shall enter the unit cabinet at a single location on side of unit (horizontal plane).
 - e. The optional stainless steel heat exchanger shall be of the tubular-section type, constructed of a minimum of 20-gauge type 409 stainless steel.
 - f. Type 409 stainless steel shall be used in heat exchanger tubes and vestibule plate.
 - g. Complete stainless steel heat exchanger allows for greater application flexibility.
 5. Induced draft combustion motor and blower
 - a. Shall be a direct-drive, single inlet, forward-curved centrifugal type.
 - b. Shall be made from steel with a corrosion-resistant finish.
 - c. Shall have permanently lubricated sealed bearings.
 - d. Shall have inherent thermal overload protection.
 - e. Shall have an automatic reset feature.

23 81 19.13.I. Coils

1. Standard Aluminum Fin/Copper Tube Coils:
 - a. Standard evaporator and condenser coils shall have aluminum lanced plate fins mechanically bonded to seamless internally grooved 5/16" diameter copper tubes with all joints brazed.
 - b. Evaporator coils shall be leak tested to 150 psig, pressure tested to 450 psig, and qualified to UL 1995 burst test at 1775 psig.
 - c. Condenser coils shall be leak tested to 150 psig, pressure tested to 650 psig, and qualified to UL 1995 burst test at 1980 psig.
2. Optional Pre-coated aluminum-fin condenser coils:
 - a. Shall have a durable epoxy-phenolic coating to provide protection in mildly corrosive coastal environments.
 - b. Coating shall be applied to the aluminum fin stock prior to the fin stamping process to create an inert barrier between the aluminum fin and copper tube.
 - c. Epoxy-phenolic barrier shall minimize galvanic action between dissimilar metals.
 - d. Corrosion durability of fin stock shall be confirmed through testing to be no less than 1000 hours salt spray per ASTM B117-90.
 - e. Corrosion durability of fin stock shall be confirmed through testing to have no visible corrosion after 48 hour immersion in a room temperature solution of 5% salt, 1% acetic acid.
 - f. Fin stock coating shall pass 2000 hours of the following: one week exposure in the prohesion chamber followed by one week of accelerated ultraviolet light testing. Prohesion chamber: the solution shall contain 3.5% sodium chloride and 0.35% ammonium sulfate. The exposure cycle is one hour of salt fog application at ambient followed by one hour drying at 95°F (35°C).
3. Optional Copper-fin evaporator and condenser coils:
 - a. Shall be constructed of copper fins mechanically bonded to copper tubes and copper tube sheets.
 - b. Galvanized steel tube sheets shall not be acceptable.
 - c. A polymer strip shall prevent coil assembly from contacting the sheet metal coil pan to minimize potential for galvanic corrosion between coil and pan.
4. Optional E-coated aluminum-fin evaporator and condenser coils:
 - a. Shall have a flexible epoxy polymer coating uniformly applied to all coil surface areas without material bridging between fins.
 - b. Coating process shall ensure complete coil encapsulation of tubes, fins and headers.
 - c. Color shall be high gloss black with gloss per ASTM D523-89.
 - d. Uniform dry film thickness from 0.8 to 1.2 mil on all surface areas including fin edges.
 - e. Superior hardness characteristics of 2H per ASTM D3363-92A and cross-hatch adhesion of 4B-5B per ASTM D3359-93.
 - f. Impact resistance shall be up to 160 in.-lb. (ASTM D2794-93).
 - g. Humidity and water immersion resistance shall be up to minimum 1000 and 250 hours respectively (ASTM D2247-92 and ASTM D870-92).

- h. Corrosion durability shall be confirmed through testing to be no less than 6000 hours salt spray per ASTM B117-90.

23 81 19.13.J. Refrigerant Components

1. Refrigerant circuit shall include the following control, safety, and maintenance features:
 - a. Thermostatic Expansion Valve (TXV) shall help provide optimum performance across the entire operating range. Shall contain removable power element to allow change out of power element and bulb without removing the valve body.
 - b. Refrigerant filter drier - Solid core design.
 - c. Service gauge connections on suction and discharge lines.
 - d. Pressure gauge access through a specially designed access screen on the side of the unit.
 - e. Single circuit design with tandem compressor and fully activated evaporator coil
2. Compressors
 - a. Models shall use fully hermetic tandem scroll compressors optimized for comfort staging and IEER energy savings.
 - b. Models shall be available with a single refrigerant circuit and three-stage cooling operation on all models.
 - c. Compressor motors shall be cooled by refrigerant gas passing through motor windings.
 - d. Compressors shall be internally protected from high discharge temperature conditions.
 - e. Compressors shall be protected from an over-temperature and over-ampere conditions by an internal, motor overload device.
 - f. Compressor shall be factory mounted on rubber grommets.
 - g. Compressor motors shall have internal line break thermal, current overload and high pressure differential protection.
 - h. Crankcase heaters shall be standard on each compressor and deactivated whenever the compressor is in operation.

23 81 19.13.K. Filter Section

1. Filters access is specified in the unit cabinet section of this specification.
2. Filters shall be held in place by a preformed, slide-out filter tray, facilitating easy removal and installation.
3. Shall consist of factory-installed, low velocity, throw-away 2-in. thick fiberglass filters.
4. Filters shall be standard, commercially available sizes.
5. Only one size filter per unit is allowed.
6. 4-in filter capability is possible with a field-installed pre-engineered slide out filter track accessory. 4-in filters are field furnished.

23 81 19.13.L. Evaporator Fan and Motor

1. Evaporator fan motor:
 - a. Shall have permanently lubricated bearings.
 - b. Shall have inherent automatic-reset thermal overload protection or circuit breaker.
 - c. Shall have a maximum continuous bhp rating for continuous duty operation; no safety factors above that rating shall be required.
 - d. Shall be Variable Frequency duty to match the three-stage compression logic.
 - e. Shall contain motor shaft grounding ring to prevent electrical bearing fluting damage by safely diverting harmful shaft voltages and bearing currents to ground.
2. Variable Frequency Drive (VFD). For indoor fan motor Staged Air Volume (SAV™) operation:
 - a. Shall be installed inside the unit cabinet, mounted, wired and tested.
 - b. Shall contain Electromagnetic Interference (EMI) frequency protection.
 - c. Insulated Gate Bi-Polar Transistors (IGBT) used to produce the output pulse width modulated (PWM) waveform, allowing for quiet motor operation.
 - d. Self-diagnostics with fault and power code LED indicator. Field accessory Display Kit available for further diagnostics and special setup applications.
 - e. RS485 capability standard.
 - f. Electronic thermal overload protection.
 - g. 5% swinging chokes for harmonic reduction and improved power factor.
 - h. All printed circuit boards shall be conformal coated.
 - i. Shall not contain visual display to adjust internal setting. Available only as field-installed kit.
3. Belt-driven Evaporator Fan:
 - a. Belt drive shall include an adjustable-pitch motor pulley.

- b. Shall use sealed, permanently lubricated ball-bearing type.
- c. Blower fan shall be double-inlet type with forward-curved blades.
- d. Shall be constructed from steel with a corrosion resistant finish and dynamically balanced.

23 81 19.13.M. Condenser Fans and Motors

1. Condenser fan motors:
 - a. Shall be a totally enclosed – multi speed ECM motor.
 - b. Shall use permanently lubricated bearings.
 - c. Shall have inherent thermal overload protection with an automatic reset feature.
 - d. Shall use a shaft-down design.
2. Condenser Fans:
 - a. Shall be a direct-driven propeller type fan.
 - b. Shall have galvanized aluminum (galvalum) blades riveted to corrosion-resistant steel spiders and shall be dynamically balanced.

23 81 19.13.N. Special Features Options and Accessories

1. Standard Leak Economizers:
 - a. Available as factory-installed option (vertical or horizontal) or field-installed accessory (vertical or horizontal) on all electro-mechanical and RTU Open models. SystemVu™ field-installed accessory (vertical or horizontal) also available.
 - b. Standard leak economizers are available with EconoMi\$er X controls for electro-mechanical units, or EconoMi\$er2 controls for RTU Open or SystemVu units.
 - c. Integrated, gear driven opposed blade design type capable of simultaneous economizer and compressor operation.
 - d. Damper blades shall be galvanized steel with composite gears. Plastic or composite blades on intake or return shall not be acceptable.
 - e. Shall be equipped with gear driven dampers for both the outdoor ventilation air and the return air for positive air stream control.
 - f. Standard leak rate models shall be equipped with leakage dampers, not to exceed 2% leakage at 1 in. wg pressure differential.
 - g. Shall be capable of introducing up to 100% outdoor air.
 - h. Economizer's barometric relief dampers shall be sized to allow up to 100% relief (actual results will be based on specific job conditions).
2. Ultra-Low Leak Economizers:
 - a. Available as a factory-installed option (vertical or horizontal) or field-installed accessory (vertical or horizontal) on all models including: electro-mechanical, RTU Open, and SystemVu.
 - b. Ultra-Low Leak economizer dampers meet California's Title 24 section 140.4 prescriptive requirements for leakage, reliability testing, etc., and ASHRAE 90.1-2013 requirements for damper leakage.
 - c. Economizers are available with EconoMi\$er X controls for electro-mechanical units, or EconoMi\$er2 controls for RTU Open or SystemVu units.
 - d. Integrated, gear driven opposed blade design type capable of simultaneous economizer and compressor operation.
 - e. Damper blades shall be galvanized steel with composite gears. Plastic or composite blades on intake or return shall not be acceptable.
 - f. Shall be equipped with gear driven dampers for both the outdoor ventilation air and the return air for positive air stream control.
 - g. Shall be capable of introducing up to 100% outdoor air.
 - h. Economizer's barometric relief dampers shall be sized to allow up to 100% relief (actual results will be based on specific job conditions).
 - (1.) EconoMi\$er X Economizer Controls:
 - a. For use with factory-installed (vertical or horizontal) or field-installed accessory (vertical or horizontal) on electro-mechanical units with standard leak or Ultra-Low Leak economizers.
 - b. Meets California's Title 24 section 120.2 mandatory requirements for economizer Fault Detection and Diagnosis (FDD).
 - c. Economizer controller shall be Honeywell W7220 JADE that provides:
 - i. 2-line LCD interface screen for setup, configuration and troubleshooting.
 - ii. On-board FDD detects and alerts when economizer is not operating properly.
 - iii. Sensor failure loss of communication identification.

- iv. Automatic sensor detection.
 - v. Capabilities for use with multi-speed indoor fan units.
 - d. Compressor lockout temperature on W7220 is adjustable from -45 to 80°F, set at a factory default of 32°F.
 - e. Shall be designed to spring return close outside air damper during loss of power.
 - f. Actuator shall be direct coupled to economizer gear. No linkage arms or control rods shall be acceptable.
 - g. Utilizes digital dry bulb or enthalpy outside air sensors. Factory-installed economizers available with dry bulb or enthalpy. Dry bulb sensors installed on all field-installed economizer accessories.
- (2.) EconoMi\$er2 Economizer Controls:
- a. For use with factory-installed (vertical or horizontal) or field-installed accessory (vertical or horizontal) on RTU Open or SystemVu™ units with standard leak or Ultra-Low Leak economizers. Note: Factory-installed EconoMi\$er2 is available on SystemVu™ units with Ultra-Low Leak economizers only.
 - b. EconoMi\$er2 economizers are controlled by RTU Open or SystemVu unit controllers, which shall be 4-20mA design.
 - c. RTU Open and SystemVu controls meet California's Title 24 section 120.2 mandatory requirements for economizer Fault Detection and Diagnosis.
 - d. Available on factory-installed (vertical only) economizers with dry bulb or enthalpy outside air sensors. Field-installed accessories (vertical or horizontal) are available with dry bulb outside air sensors only.
 - e. Outdoor air sensor setpoint shall be adjustable and shall range from 40 to 100°F (4 to 38°C). Additional sensor options shall be available as accessories.
 - f. Shall be designed to spring return close outside air damper during loss of power.
 - g. Actuator shall be direct coupled to economizer gear. No linkage arms or control rods shall be acceptable.
 - h. The economizer controller shall also provide control of an accessory power exhaust unit function. Factory set at 100%, with a range of 0% to 100%.
 - i. The economizer shall maintain minimum airflow into the building during occupied period and provide design ventilation rate for full occupancy.
 - j. Controller shall drive outside air dampers completely closed when the unit is in the unoccupied mode.
 - k. Economizer controller shall accept a 4-20mA CO₂ sensor input for IAQ/DCV control. In this mode, dampers shall modulate the outdoor air damper to provide ventilation based on the sensor input.
 - l. Economizer controller shall provide indications when in free cooling mode, in the DCV mode, or the exhaust fan contact is closed.
3. Propane Conversion Kit
- a. Package shall contain all the necessary hardware and instructions to convert a standard natural gas unit for use with liquefied propane. Kits shall be available for elevations from 0 up to 14,000 ft (4,276 m).
4. Condenser Coil Hail Guard Assembly
- a. Shall protect against damage from hail.
 - b. Shall be louvered style design.
5. Unit-Mounted, Non-Fused Disconnect Switch:
- a. Switch shall be factory-installed, internally mounted.
 - b. National Electric Code (NEC) and ETL approved non-fused switch shall provide unit power shutoff.
 - c. Shall be accessible from outside the unit.
 - d. Shall provide local shutdown and lockout capability.
 - e. Sized only for the unit as ordered from the factory. Does not accommodate field-installed devices.
6. HACR Breaker
- a. These manual reset devices provide overload and short circuit protection for the unit. Factory wired and mounted with the units, with access cover to help provide environmental protection. On 575V applications, HACR breaker can only be used with WYE power distribution systems. Use on Delta power distribution systems is prohibited.
 - b. Sized only for the unit as ordered from the factory. Does not accommodate field-installed devices.
7. Convenience Outlet:
- a. Powered convenience outlet.
 - (1.) Outlet shall be powered from main line power to the rooftop unit.
 - (2.) Outlet shall be powered from line side of disconnect by installing contractor, as required by code. If outlet is powered from load side of disconnect, unit electrical ratings shall be ETL certified and rated for additional outlet amperage.
 - (3.) Outlet shall be factory-installed and internally mounted with easily accessible 115-v female receptacle.

- (4.) Outlet shall include 15 amp GFI receptacles with independent fuse protection.
- (5.) Voltage required to operate convenience outlet shall be provided by a factory-installed step-down transformer.
- (6.) Outlet shall be accessible from outside the unit.
- (7.) Outlet shall include a field-installed "Wet in Use" cover.
- b. Non-Powered convenience outlet.
 - (1.) Outlet shall be powered from a separate 115/120v power source.
 - (2.) A transformer shall not be included.
 - (3.) Outlet shall be factory-installed and internally mounted with easily accessible 115-v female receptacle.
 - (4.) Outlet shall include 15 amp GFI receptacles with independent fuse protection.
 - (5.) Outlet shall be accessible from outside the unit.
 - (6.) Outlet shall include a field-installed "Wet in Use" cover.
- 8. Flue Discharge Deflector:
 - a. Flue discharge deflector shall direct unit exhaust vertically instead of horizontally.
 - b. Deflector shall be defined as a "natural draft" device by the National Fuel and Gas (NFG) code.
- 9. Centrifugal Propeller Power Exhaust:
 - a. Power exhaust shall be used in conjunction with an integrated economizer.
 - b. Independent modules for vertical or horizontal return configurations shall be available.
 - c. Horizontal power exhaust is shall be mounted in return ductwork.
 - d. Power exhaust shall be controlled by economizer controller operation. Exhaust fans shall be energized when dampers open past the 0-100% adjustable set point on the economizer control.
- 10. Roof Curbs (Vertical):
 - a. Full perimeter roof curb with exhaust capability providing separate air streams for energy recovery from the exhaust air without supply air contamination.
 - b. Formed galvanized steel with wood nailer strip and shall be capable of supporting entire unit weight.
 - c. Permits installation and securing of ductwork to curb prior to mounting unit on the curb.
- 11. High-Static Indoor Fan Motor(s) and Drive(s):
 - a. High-static motor(s) and drive(s) shall be factory-installed to provide additional performance range.
- 12. High Altitude Gas Conversion Kit:
 - a. Package shall contain all the necessary hardware and instructions to convert a standard natural gas unit to operate from 3,000-10,000 ft (914 to 3048 m) elevation and 10,001-14,000 ft (3049-4267 m) elevation.
- 13. Outdoor Air Enthalpy Sensor:
 - a. The outdoor air enthalpy sensor shall be used to provide single enthalpy control. When used in conjunction with a return air enthalpy sensor, the unit will provide differential enthalpy control. The sensor allows the unit to determine if outside air is suitable for free cooling.
- 14. Return Air Enthalpy Sensor:
 - a. The return air enthalpy sensor shall be used in conjunction with an outdoor air enthalpy sensor to provide differential enthalpy control.
- 15. Indoor Air Quality (CO₂) Sensor:
 - a. Shall be able to provide demand ventilation indoor air quality (IAQ) control.
 - b. The IAQ sensor shall be available in duct mount, wall mount, or wall mount with LED display. The set point shall have adjustment capability.
- 16. Smoke detectors:
 - a. Shall be a Four-Wire Controller and Detector.
 - b. Shall be environmental compensated with differential sensing for reliable, stable, and drift-free sensitivity.
 - c. Shall use magnet-activated test/reset sensor switches.
 - d. Shall have tool-less connection terminal access.
 - e. Shall have a recessed momentary switch for testing and resetting the detector.
 - f. Controller shall include:
 - (1.) One set of normally open alarm initiation contacts for connection to an initiating device circuit on a fire alarm control panel.
 - (2.) Two Form-C auxiliary alarm relays for interface with rooftop unit or other equipment.
 - (3.) One Form-C supervision (trouble) relay to control the operation of the Trouble LED on a remote test/reset station.

- (4.) Capable of direct connection to two individual detector modules.
 - (5.) Can be wired to up to 14 other duct smoke detectors for multiple fan shutdown applications
17. Horn/Strobe Annunciator
- a. Provides an audible/visual signaling device for use with factory-installed option or field-installed accessory smoke detectors.
 - (1.) Requires installation of a field-supplied 24-v transformer suitable for 4.2 VA (AC) or 3.0 VA (DC) per horn/strobe accessory.
 - (2.) Requires field-supplied electrical box, North American 1-gang box, 2-in (51 mm) x 4-in (102 mm).
 - (3.) Shall have a clear colored lens.
18. Time Guard
- a. Shall prevent compressor short cycling by providing a 5-minute delay (± 2 minutes) before restarting a compressor after shutdown for any reason.
 - b. One device shall be required per compressor.
19. Barometric Hood (Horizontal Economizer Applications)
- a. Shall be required when a horizontal economizer and barometric relief are required. Barometric relief damper must be installed in the return air (horizontal) duct work. This hood provides weather protection.
20. Hinged Access Panels
- a. Shall provide easy access through integrated quarter turn latches.
 - b. Shall be on major panels of – filter, control box, fan motor and compressor.
21. Display Kit for Variable Frequency Drive
- a. Kit allows the ability to access the VFD controller programs to provide special setup capabilities and diagnostics.
 - b. Kit contains display module and communication cable.
 - c. Display Kit can be permanently installed in the unit or used on any SAV™ system VFD controller as needed.
22. Thermostat:
- a. Due to the three-stage cooling capacity design of these units, a three-stage cooling thermostat is required for the unit to perform at listed operating efficiencies.
 - b. Carrier offers a Honeywell branded T7350D (3 Cool/3 Heat) Commercial Programmable Thermostat. This provides:
 - 7-day programmable 365-day clock with holiday programming
 - Automatic Daylight Saving Time adjustment
 - Backlit display
 - Changeover selections: automatic or manual
 - Fan configurable: continuous or intermittent during occupied
23. Humidi-MiZer® Adaptive Dehumidification System:
- a. The Humidi-MiZer Adaptive Dehumidification System shall be factory installed, certified and tested to provide greater dehumidification of the occupied space by providing two distinct models of dehumidification operation in addition to its normal design cooling mode:
 - (1.) Subcooling mode further sub cools the hot liquid refrigerant leaving the condenser coil as well as reheat leaving air stream. It can provide both better cooling capacity as well as dehumidification process when both temperature and humidity in the space are not satisfied.
 - (2.) Hot gas reheat mode shall mix a portion of the hot gas from the discharge of compressor with the hot liquid refrigerant leaving the condenser coil to create a two-phase warm refrigerant in the reheat coil which results in a neutral leaving air temperature when only humidity in the space is not satisfied.