

**48LC WeatherExpert™ Series**  
**Ultra High Efficiency Single Packaged Rooftop and**  
**Single Zone VAV**  
**Gas Heat/Electric Cooling Packaged Rooftop with**  
**Puron® (R- 410A) Refrigerant**  
**Sizes 04- 06**  
**3 to 5 Nominal Tons**



## Product Data



# WeatherExpert™



Shown with optional Economizer

C11536

**PERFORMANCE, INNOVATION, RELIABILITY**

# TABLE OF CONTENTS

	PAGE		PAGE
FEATURES AND BENEFITS .....	3	APPLICATION DATA .....	18
MODEL NUMBER NOMENCLATURE .....	4	COOLING TABLES .....	20
FACTORY OPTIONS AND/OR ACCESSORIES .....	5	ECONO, BARO RELIEF & PE PERFORMANCE ...	29
AHRI COOLING RATING TABLES .....	9	FAN PERFORMANCE .....	30
SOUND PERFORMANCE TABLE .....	10	MCA/MOCP .....	40
PHYSICAL DATA .....	11	SEQUENCE OF OPERATION .....	43
CURBS & WEIGHTS DIMENSIONS .....	13	GUIDE SPECIFICATIONS .....	46
OPTIONS AND ACCESSORY WEIGHTS .....	17		

48LC



turn to the experts™

Carrier’s rooftop units (RTU) are designed by customers for customers. These new WeatherExpert™ models are Carrier’s highest efficient models ever produced and not only help reduce energy cost while providing comfort but they also help lower total cost of ownership.

### Ultra high efficiency:

With SEER’s up to 17.5, these new WeatherExpert models well exceed both ASHRAE 90.1 and Energy Star levels for operating efficiencies. The models also meet or exceed the latest Consortium for Energy Efficiency (CEE) Tier 2 levels. All help to reduce energy cost and help qualify for rebates and contribute to obtain LEED credits.

### Easy to install:

All WeatherExpert units are field-convertible to horizontal air flow, which makes it easy to adjust to unexpected job-site complications. In fact, these new 3-5 ton 48LC rooftops fit on the same Carrier curbs dating back to 1989, making it ideal for replacement without replacing existing curbs or utilizing an adapter curb. Many factory and field installed options are also available that are pre-engineered and tested.

### Easy to maintain:

Easy access handles by Carrier provide quick access to all normally serviced components. Our “no-strip” screw system has superior holding power and guides screws into position while preventing the screw from stripping the unit’s metal. Take accurate pressure readings by reading condenser pressure with panels on. Simply remove the black, composite plug, route your gauge line(s) through the hole, and connect them to the refrigeration service valve(s). Now, you can take refrigeration system pressure readings without affecting the condenser airflow.

### Easy to use:

The newly designed control box puts all your connections and troubleshooting points in one convenient place. Most low voltage connections are made to the same board and make it easy to find what you’re looking for and easy to access it. Carrier rooftops have high and low pressure switches, a filter drier, and 2- in (51mm) filters standard.



## UNIT FEATURES

- Two stage cooling capacity control scroll compressors with crankcase heater
- Belt drive indoor fan and pulley system with Variable Frequency Drive (VFD) motor controller and display or direct drive (multi speed/torque) ECM motor.
- SEER up to 17.5 with direct drive ECM indoor fan motor, up to 16.4 SEER with belt drive/VFD indoor fan motor. VFD includes display standard on electro-mechanical and RTU open models. On ComfortLink models, VFD programs can be accessible through the ComfortLink controls.
- Electro-mechanical controls that provide cooling operation down to 10°F (-12°C)
- Optional ComfortLink Controls that provide cooling operation down to 0°F (-18°C) and:
  - Communications via stand alone thermostat or sensor
  - Scrolling marquee visual display
  - Time schedule capabilities
  - Reverse rotation protection
- Exclusive non-corrosive composite condensate pan in accordance with ASHRAE 62 Standard, sloping design; side or center drain
- Gas efficiencies up to 82%
- Induced draft combustion design
- Redundant gas valve, with up to 2 stages of heating
- Pre-painted exterior panels and primer-coated interior panels tested to 500 hours salt spray protection
- TXV refrigerant metering system on each circuit
- Fully insulated with foil faced insulation throughout the entire cabinet
- Exclusive IGC solid-state control for on-board diagnostics with LED error code designation, burner control logic and energy saving indoor fan motor delay
- Dedicated 3-5 ton “Low NOx” models available that meet California Air Quality Management NOx requirement of 40 nanogram/joule or less. Low NOx models include stainless steel heat exchangers
- Cooling operating range up to 125°F (52°C)
- Access panels with easy grip handles
- Innovative, easy starting, no-strip screw feature on unit access panels
- Two-inch disposable return air filters
- Tool-less filter access door
- New terminal board facilitating simple safety circuit troubleshooting and simplified control box arrangement
- Field Convertible airflow. Being able to convert a unit from vertical airflow to horizontal makes it easy to overcome job site complications.
- Provisions for thru-the-bottom power entry capability as standard
- Single point gas and electric connections
- Full perimeter base rail with built-in rigging adapters and fork truck slots
- 24-volt control circuit protected with resettable circuit breaker
- Permanently lubricated evaporator-fan motor
- Totally enclosed high efficient ECM outdoor fan motor with permanently lubricated bearings
- Low Pressure switch and high-pressure switch protection
- Exclusive IGC anti-cycle protection for gas heat operation
- Solid-state electronic direct spark ignition system
- Flame roll-out safety protector
- Liquid line filter drier on each circuit
- Factory-installed Humid-MiZer® Adaptive Dehumidification System on all sizes
- Standard Limited Warranty: 10 yr. aluminized heat exchanger, 15 yr. stainless steel heat exchanger, 5 yr. compressor, 3 yr. ComfortLink controller, 1 yr. parts.

# MODEL NUMBER NOMENCLATURE

1	2	3	4	5	6	7	8	9	10	11	12	13	14	15	16	17	18
4	8	L	C	D	0	0	6	A	0	A	0	-	0	A	0	A	0

## Unit Type

48 = Gas Heat Packaged  
Rooftop

## Model Series- WeatherExpert

LC = Ultra High Efficiency

## Heat Size

D = Low gas heat  
E = Medium gas heat  
F = High gas heat  
L = Low NO<sub>x</sub>, low gas heat  
M = Low NO<sub>x</sub>, medium gas heat  
N = Low NO<sub>x</sub>, high gas heat  
S = Low heat with stainless steel exchanger  
R = Med heat with stainless steel exchanger  
T = High heat with stainless steel exchanger

*(Low No<sub>x</sub> models include stainless steel HX)*

## Refrig. System Options

0 = 2- stage cooling capacity  
A = 2- stage cooling capacity with Humidi- MiZ  
erSystem (not available with ComfortLink  
controls)

## Cooling Tons

04 = 3 Ton  
05 = 4 Ton  
06 = 5 Ton

## Sensor Options

A = None  
B = RA smoke detector  
C = SA smoke detector  
D = RA & SA smoke detector  
E = CO<sub>2</sub> sensor  
F = RA smoke detector & CO<sub>2</sub>  
G = SA smoke detector & CO<sub>2</sub>  
H = RA & SA smoke detector & CO<sub>2</sub>

## Indoor Fan Options

0 = Standard Electric Direct Drive ECM Motor  
2 = Medium Static Belt Drive with VFD Controller & Display  
3 = High Static Belt Drive with VFD Controller & Display

## Brand / Packaging

0 = Standard  
1 = LTL

## Electrical Options

A = None  
B = HACR Breaker  
C = Non- fused disconnect  
D = Thru the base connections  
E = HACR Breaker & thru the base  
F = Non- fused & thru the base

## Service Options

0 = None  
1 = Unpowered convenience outlet  
2 = Powered convenience outlet  
3 = Hinged panels  
4 = Hinged panels, unpwr conv outlet  
5 = Hinged panels, pwr conv outlet

## Air Intake / Exhaust Options

A = None  
B = Standard Leak Temp econo w/baro  
relief  
E = Standard Leak Enthalpy econo w/  
baro relief  
N = Ultra Low Leak temp econo w/baro relief  
R = Ultra low leak enthalpy econo w/baro relief

## Base Unit Controls

0 = Base Electromechanical Controls  
1 = RTU Open Multi Protocol  
Direct Digital Controller (DDC)  
2 = ComfortLink Controls

## Design Rev

- Factory design revision

## Voltage

1 = 575/3/60  
5 = 208- 230/3/60  
6 = 460/3/60

## Coil Options (Outdoor- Indoor- Hail Guard)

A = Al/Cu - Al/Cu  
B = Pre- coat Al/Cu - Al/Cu  
C = E coat Al/Cu - Al/Cu  
D = E coat Al/Cu- E coat Al/Cu  
E = Cu/Cu- Al/Cu  
F = Cu/Cu - Cu/Cu  
M = Al/Cu - Al/Cu - Louvered Hail Guard  
N = Pre- coat Al/Cu - Al/Cu - Louvered Hail Guard  
P = E- coat Al/Cu - Al/Cu - Louvered Hail Guard  
Q = E- coat Al/Cu - E- coat Al/Cu - Louvered Hail Guard  
R = Cu/Cu- Al/Cu- Louvered Hail Guard  
S = Cu/Cu- Cu/Cu- Louvered Hail Guard

**Table 1 – FACTORY-INSTALLED OPTIONS AND FIELD-INSTALLED ACCESSORIES**

CATEGORY	ITEM	FACTORY INSTALLED OPTION	FIELD INSTALLED ACCESSORY
<b>Cabinet</b>	Thru- the- base electrical or gas- line connections	X	X
	Hinged access panels	X	
<b>Coil Options</b>	Cu/Cu indoor and/or outdoor coils	X	
	Pre- coated outdoor coils	X	
	Premium, E- coated outdoor coils	X	
<b>Humidity Control</b>	Humidi- MiZer® Adaptive Dehumidification System <sup>1</sup>	X	
<b>Condenser Protection</b>	Condenser coil hail guard (louvered design)	X	X
<b>Controls</b>	Thermostats, temperature sensors, and subbases		X
	ComfortLink Controls	X	
	RTU Open Multi- Protocol Direct Digital Controller (DDC)	X	
	Smoke detector (supply and/or return air) <sup>8</sup>	X	
	Time Guard compressor delay control circuit		X
	Phase Monitor		X
<b>Economizers &amp; Outdoor Air Dampers</b>	EconoMi\$er X for electro- mechanical controls, complies with FDD. (Standard and Ultra Low Leak air damper models) <sup>6</sup>	X	X
	EconoMi\$er2 for DDC controls, complies with FDD. (Standard and Ultra Low Leak air damper models) <sup>7</sup>	X	X
	Barometric relief <sup>2</sup>	X	X
	Power exhaust		X
<b>Economizer Sensors &amp; IAQ Devices</b>	Single dry bulb temperature sensors <sup>3</sup>	X	X
	Differential dry bulb temperature sensors <sup>3</sup>		X
	Single enthalpy sensors <sup>3</sup>	X	X
	Differential enthalpy sensors <sup>3</sup>		X
	Wall or duct mounted CO <sub>2</sub> sensor <sup>3</sup>		X
	Unit mounted CO <sub>2</sub> sensor <sup>3</sup>	X	
<b>Gas Heat</b>	Propane conversion kit		X
	Stainless steel heat exchanger	X	
	High altitude conversion kit		X
	Flue Shield		X
	Flue Discharge Deflector		X
<b>Indoor Motor &amp; Drive</b>	Multiple motor and drive packages	X	
<b>Power Options</b>	Convenience outlet (powered) <sup>4</sup>	X	
	Convenience outlet (unpowered)	X	
	HACR circuit breaker <sup>5</sup>	X	
	Non- fused disconnect	X	
<b>Roof Curbs</b>	Roof curb 14- in (356mm)		X
	Roof curb 24- in (610mm)		X

**NOTES:**

- 1 Not available with ComfortLink controls.
- 2 Included with economizer.
- 3 Sensors used to optimize economizer performance.
- 4 Not available on 460 or 575 volt models.
- 5 On 575V applications, HACR breaker can only be used with WYE power distribution systems. Using on Delta power distribution systems is prohibited.
- 6 FDD - (Fault Detection and Diagnostic) capability per California Title 24 section 120.2.
- 7 Models with RTU Open and ComfortLink DDC controls comply with California Title 24 Fault Detection and Diagnostic (FDD).
- 8 Return Air Smoke Detector not available for horizontal air flow models.

48LC

## FACTORY OPTIONS AND/OR ACCESSORIES

### Economizer

Economizers save energy, money and improve comfort levels in the conditioned space. They bring in fresh, outside air for ventilation; and provide cool outside air to cool your building. This also is the preferred method of low ambient cooling. When integrated with CO<sub>2</sub> sensors, economizers can provide even more savings by coupling the ventilation air to only that amount required based on space occupancy.

Economizers are available, installed and tested by the factory, with either enthalpy or temperature dry-bulb inputs. There are also models for electromechanical and direct digital controls. Additional sensors are available as accessories to optimize the economizer.

Economizers include gravity controlled barometric relief that helps equalize building pressure and ambient air pressures. This can be a cost effective solution to prevent building pressurization. Economizers are available in Ultra Low Leak and standard low leak versions.

### CO<sub>2</sub> Sensor

Improves productivity and saves money by working with the economizer to intake only the correct amount of outside air for ventilation. As occupants fill your building, the CO<sub>2</sub> sensor detects their presence through increasing CO<sub>2</sub> levels, and opens the economizer appropriately.

When the occupants leave, the CO<sub>2</sub> levels decrease, and the sensor appropriately closes the economizer. This intelligent control of the ventilation air, called Demand Control Ventilation (DCV) reduces the overall load on the rooftop, saving money.

### Smoke Detectors

Trust the experts. Smoke detectors make your application safer and your job easier. Carrier smoke detectors immediately shut down the rooftop unit when smoke is detected. They are available, installed by the factory, for supply air, return air, or both.

### Louvered Hail Guards

Sleek, louvered panels protect the condenser coil from hail damage, foreign objects, and incidental contact.

### Convenience Outlet (powered or un-powered)

Reduce service and/or installation costs by including a convenience outlet in your specification. Carrier will install this service feature at our factory. Provides a convenient, 15 amp, 115v GFCI receptacle with “Wet in Use” cover. The “powered” option allows the installer to power the outlet from the line side of the disconnect or load side as required by code. The “unpowered” option is to be powered from a separate 115/120v power source.

**NOTE:** Powered convenience outlets are not available on 460 and 575 volt units.

### Non-fused Disconnect

This OSHA-compliant, factory-installed, safety switch allows a service technician to locally secure power to the rooftop.

### Power Exhaust with Barometric Relief

Superior internal building pressure control. This field-installed accessory may eliminate the need for costly, external pressure control fans.



## **RTU Open, Multi-Protocol Controller**

Connect the rooftop to an existing BAS without needing complicated translators or adapter modules using the RTU Open controller. This new controller speaks the 4 most common building automation system languages (Bacnet, Modbus, N2, and Lonworks). Use this controller when you have an existing BAS. Besides the 4 protocols, it also communicates with a Carrier Open system (I-Vu and VVT).

## **Time Guard II Control Circuit**

This accessory protects your compressor by preventing short-cycling in the event of some other failure, prevents the compressor from restarting for 30 seconds after stopping. Not required with RTU Open or authorized commercial thermostats.

## **Manual OA Damper & Two Position Dampers**

Both Manual and Two Position Dampers are not recommended due to the control logic required for the 2-Speed indoor fan system for maintaining proper ventilation requirements. Contact application engineering for more details.

## **Hinged Access Panels**

Allows access to unit's major components with specifically designed hinged access panels. Panels are: filter, control box, fan motor and compressor. Comes with quarter turn latches and lift tabs.

## **Propane Heating**

Convert your gas heat rooftop from standard natural gas operation to Propane using this field-installed kit.

## **High Altitude Heating**

High altitudes have less oxygen, which means heat exchangers need less fuel. The new gas orifices in this field-installed kit make the necessary adjustment for high altitude applications. They restore the optimal fuel to air mixture and maintain healthy combustion at altitudes above 2000 ft (610m). Kits may not be required in all areas.

## **Flue Discharge Deflector**

The flue discharge deflector is a useful accessory when flue gas recirculation is a concern. By venting the flue discharge upwards, the deflector minimizes the chance for a neighboring unit to intake the flue exhaust.

## **Optional Stainless Steel Heat Exchanger**

The stainless steel heat exchanger option provides the tubular heat exchanger be made out of a minimum 20 gauge type 409 stainless steel for applications where the mixed air to the heat exchanger is expected to drop below 45°F (7°C). Stainless steel may be specified on applications where the presence of airborne contaminants require its use (applications such as paper mills) or in area with very high outdoor humidity that may result in severe condensation in the heat exchanger during cooling operation.

## FACTORY OPTIONS AND/OR ACCESSORIES (cont.)

### Flue Discharge Heat Shield

The flue discharge heat shield keeps people from touching the rooftop unit's potentially hot flue discharge. This is especially useful for ground level applications, where more, untrained people could have access to the unit's exterior.

### HACR Breaker

These manual reset devices provide overload and short circuit protection for the unit. Factory wired and mounted with the units with access cover to help provide environment protection.

On 575V applications, HACR breaker can only be used with WYE power distribution systems. Use on Delta power distribution systems is prohibited.

### Alternate Motors and Drives

Some applications need larger horsepower motors, some need more airflow, and some need both. Regardless of the case, your Carrier expert has a factory installed combination to meet your application. A wide selection of motors and pulleys (drives) are available, factory installed, to handle nearly any application.

### Optional Humidi-MiZer® Adaptive Dehumidification System

Carrier's Humidi-MiZer adaptive dehumidification system is an all-inclusive factory installed option that can be ordered with any WeatherExpert rooftop unit.

This system expands the envelope of operation of Carrier's WeatherExpert rooftop products to provide unprecedented flexibility to meet year round comfort conditions.

The Humidi-MiZer adaptive dehumidification system has the industry's only dual dehumidification mode setting. The Humidi-MiZer system provides greater dehumidification of the occupiable space by two modes of dehumidification operation in addition to its normal design cooling mode.

The 48LC WeatherExpert rooftop coupled with the Humidi-MiZer system is capable of operating in normal design cooling mode, subcooling mode, and hot gas reheat mode. Normal design cooling mode is when the unit will operate under its normal sequence of operation by cycling compressors to maintain comfort conditions.

Subcooling mode will operate to satisfy part load type conditions when the space requires combined sensible and a higher proportion of latent load control. Hot Gas Reheat mode will operate when outdoor temperatures diminish and the need for latent capacity is required for sole humidity control. Hot Gas Reheat mode will provide neutral air for maximum dehumidification operation.

### Thru-the-Base Connections

Thru-the-base connections, available as either an accessory or as a factory option, are necessary to ensure proper connection and seal when routing wire and piping through the rooftop's basepan and curb. These couplings eliminate roof penetration and should be considered for gas lines, main power lines, as well as control power.

### ComfortLink Controls

Models with the optional Carrier ComfortLink Controls allow added unit diagnostics and operation setup capabilities, as well as controlling logic for single zone Variable Air Volume (VAV) applications.

The ComfortLink control is your link to a world of simple and easy to use rooftop units that offer outstanding performance and value. When used with a space temperature sensor, the ComfortLink control's intelligence maintains control over the economizer and condenser fans. It optimizes the performance of the refrigeration circuits as conditions change, resulting in the following features:

- Better control of temperature and humidity
- Superior reliability
- Automatic redundancy
- Low ambient cooling operation to 0°F
- More accurate diagnostics, at unit or remote

The ComfortLink Scrolling Marquee is very easy to use. The messages are displayed in easy to understand English, no decoding is required. A scrolling readout provides detailed explanations of control information. Only four, large, easy-to-use buttons are required to maneuver through the entire menu. The readout is designed to be visible even in the brightest sunlight. A handheld Navigator accessory or wall-mounted System Pilot™ accessory can be used for added service flexibility.

The ComfortLink control provides unparalleled service diagnostic information. Temperature and pressure can be read directly from the display with no need for separate gauges. Other data, such as compressor cycles, unit run time hours, current alarms, can also be accessed. A history of alarms is also available for viewing.

The service run test can be very helpful when troubleshooting. The user can run test major components to determine the root cause of a problem. The unit can be run-tested before an installation is complete to ensure satisfactory start-up. To ensure reliability, the ComfortLink control prevents reverse compressor rotation. No laptop computers are required for start-up.

Time schedules are built in and the Scrolling Marquee display provides easy access to setpoints. The ComfortLink control accepts input from a CO2 sensor and a smoke detector. Both are available as factory installed options or as field installed accessories.



**Table 2 – AHRI COOLING RATING TABLE 2-STAGE COOLING W/DIRECT DRIVE ECM INDOOR MOTOR**

48LC	COOLING STAGES	NOM. CAPACITY (TONS)	NET COOLING CAPACITY (MBH)	TOTAL POWER (kW)	SEER	EER
04	2	3	35.6	2.8	17.1	12.8
05	2	4	47.5	3.6	17.5	13.1
06	2	5	58.5	4.6	17.2	12.7

**Table 3 – AHRI COOLING RATING TABLE 2-STAGE COOLING WITH BELT DRIVE INDOOR MOTOR**

48LC	COOLING STAGES	NOM. CAPACITY (TONS)	NET COOLING CAPACITY (MBH)	TOTAL POWER (kW)	SEER	EER
04	2	3	34.6	2.9	15.5	12.0
05	2	4	46.5	3.7	16.4	12.6
06	2	5	58.0	4.7	16.2	12.3

**LEGEND**

- - Not Applicable
- AHRI - Air Conditioning, Heating and Refrigeration Institute Test Standard
- ASHRAE - American Society of Heating, Refrigerating and Air Conditioning, Inc.
- EER - Energy Efficiency Ratio
- SEER - Seasonal Energy Efficiency Ratio

**NOTES:**

- 1 Rated in accordance with AHRI Standards.
- 2 Ratings are based on:  
Cooling Standard: 80°F (27°C) db, 67°F (19°C) wb indoor air temp and 95°F (35°C) db outdoor air temp.
- 3 All 48LC units comply with ASHRAE 90.1 Energy Standard for minimum SEER and EER requirements.
- 4 48LC units comply with US Energy Policy Act. To evaluate code compliance requirements, refer to state and local codes.

**Table 4 – HEATING RATING TABLE - NATURAL GAS & PROPANE**

48LC	GAS HEAT	AL/SS HEAT EXCHANGER		TEMP RISE (DEG F)	THERMAL EFFICIENCY (%)
		INPUT / OUTPUT STAGE 1 (MBH)	INPUT / OUTPUT STAGE 2 (MBH)		
04	LOW	50 / 41	72 / 56	25 - 55	82%
	MED	82 / 66	115 / 89	55 - 85	81%
	HIGH	-	-	-	-
05	LOW	50 / 41	72 / 56	25 - 55	82%
	MED	82 / 66	115 / 90	35 - 65	81%
	HIGH	120 / 96	150 / 117	50 - 80	80%
06	LOW	50 / 41	72 / 56	20 - 55	82%
	MED	82 / 66	115 / 90	30 - 65	81%
	HIGH	120 / 96	150 / 117	40 - 80	80%

- Not Applicable

**NOTES:**

Heat ratings are for natural gas heat exchangers operated at or below 2000 ft (610 m). For information on Propane or altitudes above 2000 ft (610 m), see the Application Data section of this book. Accessory Propane/High Altitude kits are also available.

In the USA the input rating for altitudes above 2000 ft (610m) must be derated by 4% for each 1000 ft (305 m) above sea level. In Canada, the input rating must be derated by 10% for altitudes of 2000 ft (610 m) to 4500 ft (1372 m) above sea level.

48LC

**Table 5 – HEATING RATING TABLE - LOW NO<sub>x</sub><sup>1</sup>**

48LC	GAS HEAT	LOW NO <sub>x</sub> HEAT EXCHANGER		TEMP RISE (DEG F)	THERMAL EFFICIENCY (%)
		INPUT / OUTPUT STAGE 1 (MBH)	INPUT / OUTPUT STAGE 2 (MBH)		
04	LOW	-	60 / 47	20 - 50	81%
	MED	-	90 / 72	30 - 60	81%
	HIGH	-	-	-	-
05	LOW	-	60 / 47	20 - 50	81%
	MED	-	90 / 72	30 - 60	81%
	HIGH	-	120 / 97	40 - 70	81%
06	LOW	-	60 / 47	15 - 50	81%
	MED	-	90 / 72	25 - 60	80%
	HIGH	-	120 / 97	35 - 70	80%

- Not Applicable

**NOTE:**

1. Units meet California’s South Coast Air Quality Management District (SCAQMD) Low- NO<sub>x</sub> emissions requirement of 40 nanograms per joule or less.

**Table 6 – SOUND PERFORMANCE TABLE**

48LC	OUTDOOR SOUND (dB) AT 60								
	A- WEIGHTED	63	125	250	500	1000	2000	4000	8000
04	76	78.2	78.0	74.2	73.3	70.6	66.0	62.4	56.9
05	78	84.7	83.6	77.1	74.6	72.3	68.3	64.7	60.9
06	77	87.5	82.5	76.1	73.6	71.3	67.1	64.1	60.0

**LEGEND**

dB - Decibel

**NOTES:**

- 1 Outdoor sound data is measure in accordance with AHRI.
- 2 Measurements are expressed in terms of sound power. Do not compare these values to sound pressure values because sound pressure depends on specific environmental factors which normally do not match individual applications. Sound power values are independent of the environment and therefore more accurate.
- 3 A- weighted sound ratings filter out very high and very low frequencies, to better approximate the response of “average” human ear. A- weighted measurements for Carrier units are taken in accordance with AHRI.

**Table 7 – MINIMUM - MAXIMUM AIRFLOW RATINGS - NATURAL GAS & PROPANE**

UNIT	HEAT LEVEL	CFM					
		COOLING		AL HX HEATING		SS HX HEATING	
		MINIMUM	MAXIMUM	MINIMUM	MAXIMUM	MINIMUM	MAXIMUM
48LC**04	LOW			990	2190	990	2190
	MED	900	1500	1000	1550	1000	1550
	HIGH			-	-	-	-
48LC**05	LOW			990	2190	990	2190
	MED	1200	2000	1330	2460	1330	2460
	HIGH			1390	2220	1390	2220
48LC**06	LOW			990	2730	990	2730
	MED	1500	2500	1330	2880	1330	2880
	HIGH			1390	2780	1390	2780

**NOTE:** Indoor fan runs at high speed in heating. High speed CFM must be set above minimum CFM per this table.

**Table 8 – PHYSICAL DATA**

**(COOLING)**

**3 - 5 TONS**

		48/50LC*004	48/50LC*A04	48/50LC*005	48/50LC*A05	48/50LC*006	48/50LC*A06
<b>Refrigeration System</b>							
# Circuits / # Comp. / Type		1 / 1 / Scroll	1 / 1 / Scroll	1 / 1 / Scroll	1 / 1 / Scroll	1 / 1 / Scroll	1 / 1 / Scroll
R- 410a charge A/B (lbs - oz)		9 - 2		9 - 0		11 - 0	
Humidimizer R- 410a charge A/B (lbs - oz)			11 - 8		15 - 10		16 - 5
Metering device		TXV	TXV	TXV	TXV	TXV	TXV
High- press. Trip / Reset (psig)		630 / 505	630 / 505	630 / 505	630 / 505	630 / 505	630 / 505
Low- press. Trip / Reset (psig)		27 / 44	27 / 44	27 / 44	27 / 44	27 / 44	27 / 44
<b>Evap. Coil</b>							
Material		Cu / Al	Cu / Al	Cu / Al	Cu / Al	Cu / Al	Cu / Al
Coil type		3/8" RTPF	3/8" RTPF	3/8" RTPF	3/8" RTPF	3/8" RTPF	3/8" RTPF
Rows / FPI		3 / 15	3 / 15	3 / 15	3 / 15	4 / 15	4 / 15
total face area (ft <sup>2</sup> )		5.5	5.5	7.3	7.3	7.3	7.3
Condensate drain conn. size		3/4"	3/4"	3/4"	3/4"	3/4"	3/4"
<b>HumidMizer Coil</b>							
Material		N/A	Cu/Al	N/A	Cu/Al	N/A	Cu/Al
Coil type		N/A	3/8" RTPF	N/A	3/8" RTPF	N/A	3/8" RTPF
Rows / FPI		N/A	1 / 17	N/A	2/17	N/A	2/17
total face area (ft <sup>2</sup> )		N/A	3.9	N/A	5.2	N/A	5.2
<b>Evap. fan and motor</b>							
Standard Static	Motor Qty / Drive type	1 / Direct ECM	1 / Direct ECM	1 / Direct ECM	1 / Direct ECM	1 / Direct ECM	1 / Direct ECM
	Max BHP	1	1	1	1	1	1
	RPM range	600- 1200	600- 1200	600- 1200	600- 1200	600- 1200	600- 1200
	motor frame size	48	48	48	48	48	48
	Fan Qty / Type	1 / Centrifugal	1 / Centrifugal	1 / Centrifugal	1 / Centrifugal	1 / Centrifugal	1 / Centrifugal
	Fan Diameter (in)	10 x 10	10 x 10	10 x 10	10 x 10	11 x 10	11 x 10
Medium Static	Motor Qty / Drive type	1 / Belt	1 / Belt	1 / Belt	1 / Belt	1 / Belt	1 / Belt
	Max BHP	1.7	1.7	1.7	1.7	2.4	2.4
	RPM range	770- 1175	770- 1175	920- 1303	920- 1303	1035- 1466	1035- 1466
	motor frame size	56	56	56	56	56	56
	Fan Qty / Type	1 / Centrifugal	1 / Centrifugal	1 / Centrifugal	1 / Centrifugal	1 / Centrifugal	1 / Centrifugal
	Fan Diameter (in)	10 x 10	10 x 10	10 x 10	10 x 10	10 x 10	10 x 10
High Static	Motor Qty / Drive type	1 / Belt	1 / Belt	1 / Belt	1 / Belt	1 / Belt	1 / Belt
	Max BHP	2.4	2.4	2.9	2.9	2.9	2.9
	RPM range	1035- 1466	1035- 1466	1208- 1639	1208- 1639	1303- 1687	1303- 1687
	motor frame size	56	56	56	56	56	56
	Fan Qty / Type	1 / Centrifugal	1 / Centrifugal	1 / Centrifugal	1 / Centrifugal	1 / Centrifugal	1 / Centrifugal
	Fan Diameter (in)	10 x 10	10 x 10	10 x 10	10 x 10	10 x 10	10 x 10
<b>Cond. Coil</b>							
Material		Cu / Al	Cu / Al	Cu / Al	Cu / Al	Cu / Al	Cu / Al
Coil type		7mm RTPF	7mm RTPF	7mm RTPF	7mm RTPF	7mm RTPF	7mm RTPF
Rows / FPI		2 / 20	2 / 20	2 / 20	2 / 20	2 / 20	2 / 20
total face area (ft <sup>2</sup> )		16.4	16.4	21.4	21.4	21.4	21.4
<b>Cond. fan / motor</b>							
Qty / Motor drive type		1 / direct	1 / direct	1 / direct	1 / direct	1 / direct	1 / direct
Motor HP / RPM		1/3 / 1001	1/3 / 1001	1/3 / 1082	1/3 / 1001	1/3 / 1082	1/3 / 1082
Fan diameter (in)		22	22	22	22	22	22
<b>Filters</b>							
RA Filter # / size (in)		2 / 16 x 25 x 2	2 / 16 x 25 x 2	4 / 16 x 16 x 2	4 / 16 x 16 x 2	4 / 16 x 16 x 2	4 / 16 x 16 x 2
OA inlet screen # / size (in)		1 / 20 x 24 x 1	1 / 20 x 24 x 1	1 / 20 x 24 x 1	1 / 20 x 24 x 1	1 / 20 x 24 x 1	1 / 20 x 24 x 1

**48LC**

**Table 9 – PHYSICAL DATA**

**(HEATING)**

**3 - 5 TONS**

		<b>48LC*004</b>	<b>48LC*005</b>	<b>48LC*006</b>
<b>Gas Connection</b>	# of Gas Valves	1	1	1
	Nat. gas supply line press (in. w.g.) / (PSIG)	4 - 13 / 0.18 - 0.47	4 - 13 / 0.18 - 0.47	4 - 13 / 0.18 - 0.47
	LP supply line press (in. w.g.) / (PSIG)	11 - 13 / 0.40 - 0.47	11 - 13 / 0.40 - 0.47	11 - 13 / 0.40 - 0.47
	<b>Heat Anticipator setting (Amps)</b>			
	1st stage	0.14	0.14	0.14
	2nd stage	0.14	0.14	0.14
<b>Natural Gas Heat</b>				
LOW	# of stages / # of burners (total)	1 or 2 / 2	1 or 2 / 2	1 or 2 / 2
	Connection Size	1/2" NPT	1/2" NPT	1/2" NPT
	Rollout switch opens / closes	195 / 115	195 / 115	195 / 115
	Temperature Rise	25 - 55	25 - 55	20 - 55
MED	# of stages / # of burners (total)	1 or 2 / 3	1 or 2 / 3	1 or 2 / 3
	Connection Size	1/2" NPT	1/2" NPT	1/2" NPT
	Rollout switch opens / closes	195 / 115	195 / 115	195 / 115
	Temperature Rise	55 - 85	35 - 65	30 - 65
HIGH	# of stages / # of burners (total)	- - -	1 or 2 / 3	1 or 2 / 3
	Connection Size	- - -	1/2" NPT	1/2" NPT
	Rollout switch opens / closes	- - -	195 / 115	195 / 115
	Temperature Rise	- - -	50 - 80	40 - 80
<b>Liquid Propane Heat</b>				
LOW	# of stages / # of burners (total)	1 or 2 / 2	1 or 2 / 2	1 or 2 / 2
	Connection Size	1/2" NPT	1/2" NPT	1/2" NPT
	Rollout switch opens / closes	195 / 115	195 / 115	195 / 115
	Temperature Rise	25 - 55	25 - 55	20 - 55
MED	# of stages / # of burners (total)	1 or 2 / 3	1 or 2 / 3	1 or 2 / 3
	Connection Size	1/2" NPT	1/2" NPT	1/2" NPT
	Rollout switch opens / closes	195 / 115	195 / 115	195 / 115
	Temperature Rise	55 - 85	35 - 65	30 - 65
HIGH	# of stages / # of burners (total)	- - -	1 or 2 / 3	1 or 2 / 3
	Connection Size	- - -	1/2" NPT	1/2" NPT
	Rollout switch opens / closes	- - -	195 / 115	195 / 115
	Temperature Rise	- - -	50 - 80	40 - 80
<b>Low NOx Gas Heat</b>				
LOW	# of stages / # of burners (total)	1 or 2 / 2	1 or 2 / 2	1 or 2 / 2
	Connection Size	1/2" NPT	1/2" NPT	1/2" NPT
	Rollout switch opens / closes	195 / 115	195 / 115	195 / 115
	Temperature Rise	20 - 50	20 - 50	15 - 50
MED	# of stages / # of burners (total)	1 or 2 / 3	1 or 2 / 3	1 or 2 / 3
	Connection Size	1/2" NPT	1/2" NPT	1/2" NPT
	Rollout switch opens / closes	195 / 115	195 / 115	195 / 115
	Temperature Rise	30 - 60	30 - 60	25 - 60
HIGH	# of stages / # of burners (total)	- - -	1 or 2 / 3	1 or 2 / 3
	Connection Size	- - -	1/2" NPT	1/2" NPT
	Rollout switch opens / closes	- - -	195 / 115	195 / 115
	Temperature Rise	- - -	40 - 70	35 - 70

- Not Applicable

48LC

# CURBS & WEIGHTS DIMENSIONS

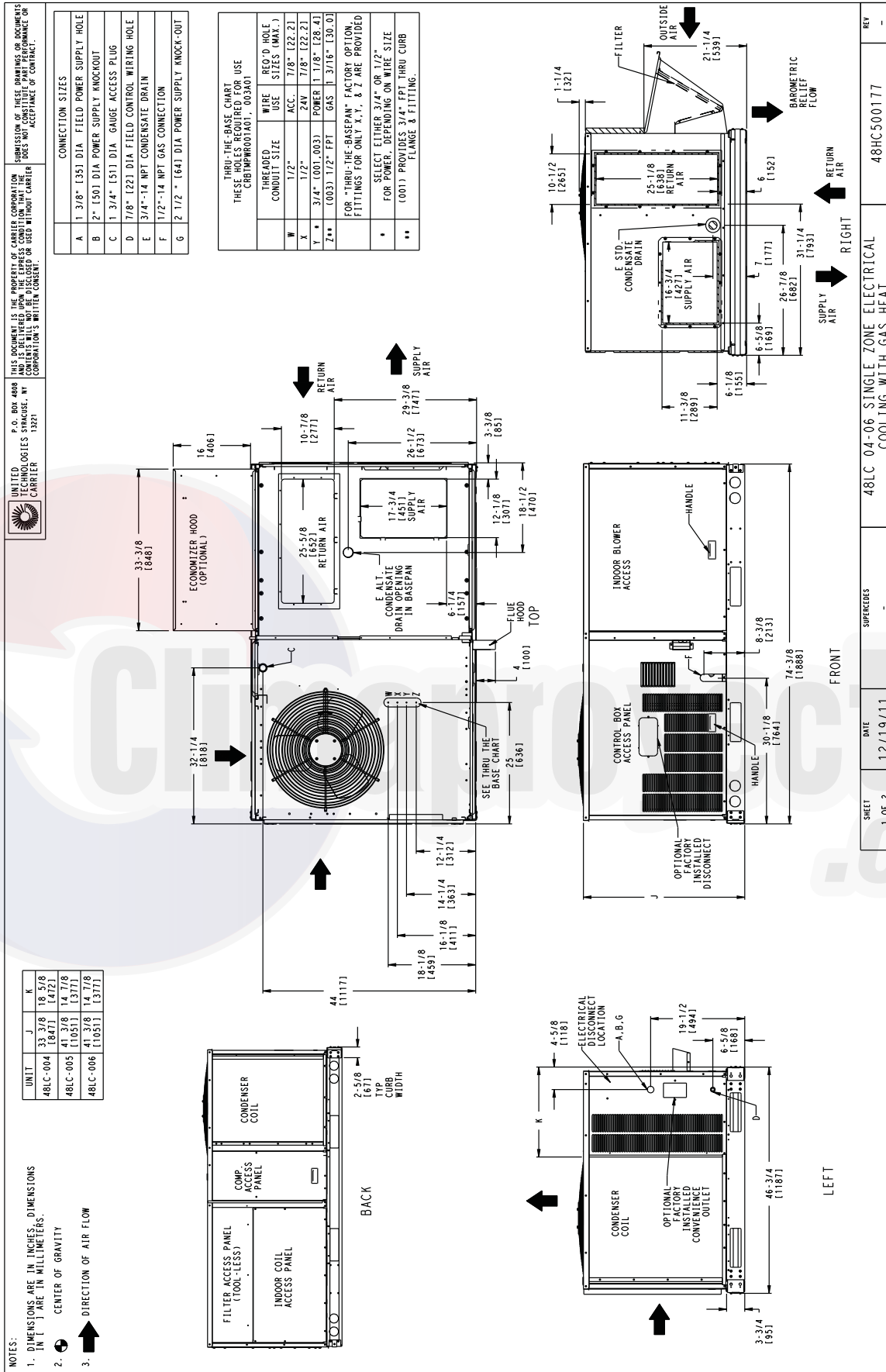

Fig. 1 - Dimensions 48LC 04-06

48LC

# CURBS & WEIGHTS DIMENSIONS (cont.)

48LC

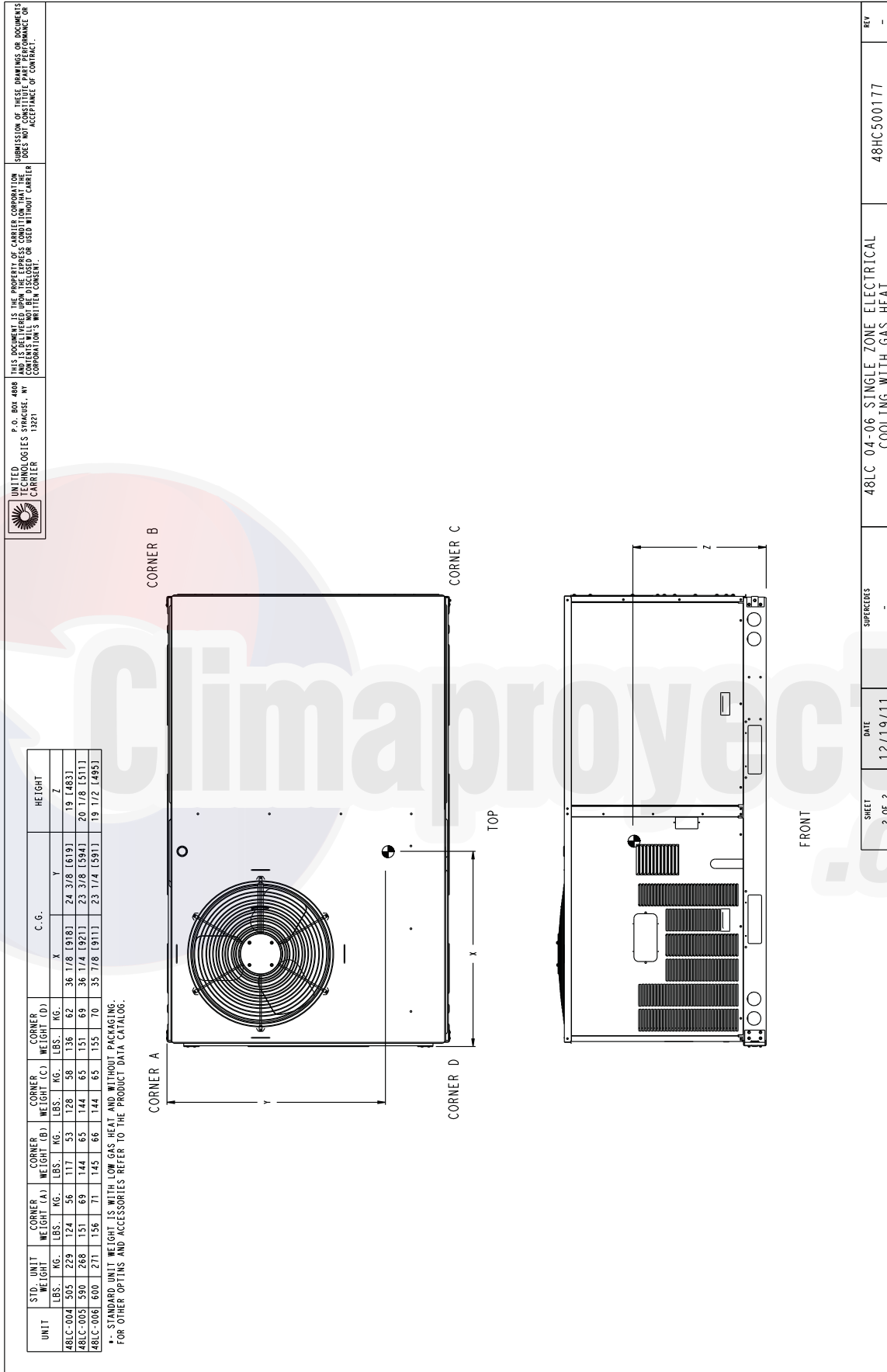
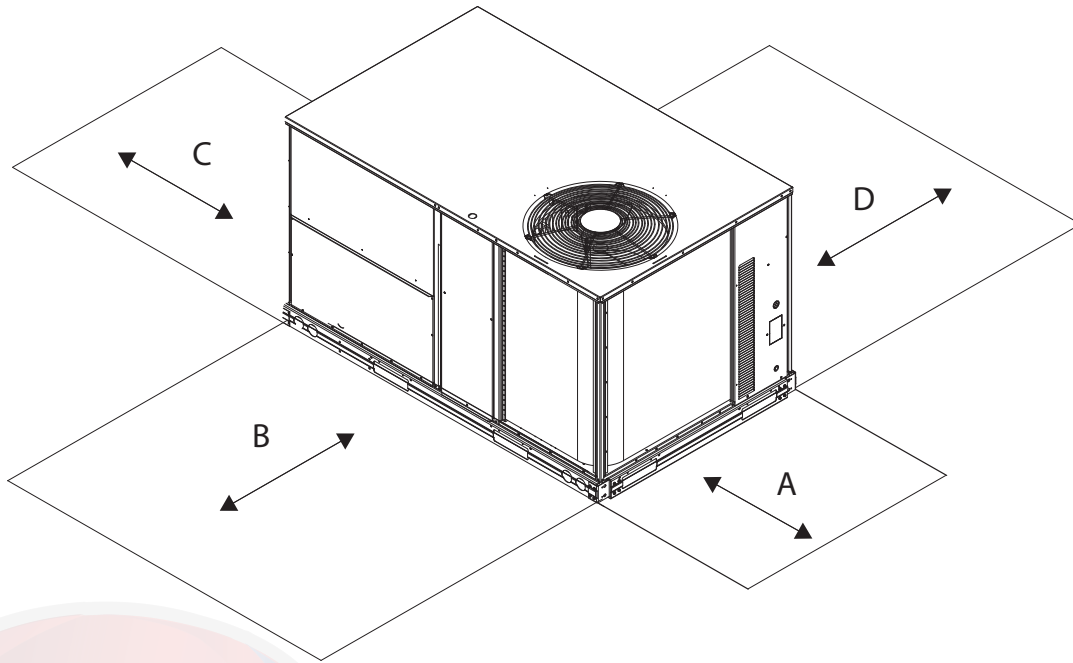

Fig. 2 - Dimensions 48LC 04-06



## CURBS & WEIGHTS DIMENSIONS (cont.)



48LC

C08337

LOCATION	DIMENSION	CONDITION
A	48- in (1219 mm) 18- in (457 mm) 18- in (457 mm) 12- in (305 mm)	Unit disconnect is mounted on panel No disconnect, convenience outlet option Recommended service clearance Minimum clearance
B	40- in (1067 mm) 36- in (914 mm) Special	Surface behind servicer is grounded (e.g., metal, masonry wall) Surface behind servicer is electrically non- conductive (e.g., wood, fiberglass) Check sources of flue products within 10- ft of unit fresh air intake hood
C	36- in (914 mm) 18- in (457 mm)	Side condensate drain is used Minimum clearance
D	48- in (1219 mm) 42- in (1067 mm) 36- in (914 mm) Special	No flue discharge accessory installed, surface is combustible material Surface behind servicer is grounded (e.g., metal, masonry wall, another unit) Surface behind servicer is electrically non- conductive (e.g., wood, fiberglass) Check for adjacent units or building fresh air intakes within 10- ft (3 m) of this unit's flue outlet

**NOTE:** Unit not designed to have overhead obstruction. Contact Application Engineering for guidance on any application planning overhead obstruction or for vertical clearances.

**Fig. 3 - Service Clearance Dimensional Drawing**



## OPTIONS & ACCESSORY WEIGHTS

OPTION / ACCESSORY	OPTION / ACCESSORY WEIGHTS					
	04		05		06	
	lb	kg	lb	kg	lb	kg
Humidi- MiZer	50	23	55	25	55	25
Power Exhaust - vertical	50	23	50	23	50	23
Power Exhaust - horizontal	30	14	30	14	30	14
EconoMi\$er (X or 2)	50	23	50	23	50	23
Medium Gas Heat	12	5	9	4	9	4
High Gas Heat	-	-	17	8	17	8
Hail Guard (louvered)	16	7	16	7	16	7
Cu/Cu Condenser Coil	35	16	35	16	35	16
Cu/Cu Condenser and Evaporator Coils	60	27	60	27	90	41
Roof Curb (14- in. curb)	115	43	115	43	115	43
Roof Curb (24- in. curb)	197	74	197	74	197	74
CO <sub>2</sub> sensor	5	2	5	2	5	2
Flue Discharge Deflector	7	3	7	3	7	3
Optional Indoor Motor/Drive	10	5	10	5	10	5
Motor Master Controller	35	16	35	16	35	16
Return Smoke Detector	5	2	5	2	5	2
Supply Smoke Detector	5	2	5	2	5	2
Fan/Filter Status Switch	2	1	2	1	2	1
Non- Fused Disconnect	15	7	15	7	15	7
Powered Convenience outlet	35	16	35	16	35	16
Non- Powered Convenience outlet	5	2	5	2	5	2
Enthalpy Sensor	2	1	2	1	2	1
Differential Enthalpy Sensor	3	1	3	1	3	1
HACR Breaker	15	7	15	7	15	7

48LC



## APPLICATION DATA

### Min operating ambient temp (cooling):

In mechanical cooling mode, your Carrier rooftop unit can safely operate down to an outdoor ambient temperature of 10°F (-12°C) and down to 0°F (-18°C) with ComfortLink controls. It is possible to provide cooling at lower outdoor ambient temperatures by using less outside air, economizers, and/or accessory low ambient kits.

### Max operating ambient temp (cooling):

The maximum operating ambient temperature for cooling mode is 125°F (52°C). While cooling operation above 125°F (52°C) may be possible, it could cause either a reduction in performance, reliability, or a protective action by the unit's internal safety devices.

### Min mixed air temp (heating):

Using the factory settings, the minimum temperatures for the mixed air (the combined temperature of the warm return air and the cold outdoor air) entering the dimpled, gas heat exchangers are:

<u>Aluminized</u>	<u>Stainless Steel</u>
50°F (10°C) continuous	40°F (4°C) continuous
45°F (7°C) intermittent	35°F (2°C) intermittent

Operating at lower mixed-air temperatures may be possible, if a field-supplied, outdoor air thermostat initiates both heat stages when the temperature is less than the minimum temperatures listed above. Please contact your local Carrier representative for assistance.

### Min and max airflow (heating and cooling):

To maintain safe and reliable operation of your rooftop, operate within the heating airflow limits during heating mode and cooling airflow limits during cooling mode. Operating above the max may cause blow-off, undesired airflow noise, or airflow related problems with the rooftop unit. Operating below the min may cause problems with coil freeze-up and unsafe heating operation. Heating and cooling limitations differ when evaluating operating CFM, the minimum value is the HIGHER of the cooling and heating minimum CFM values published in Table 7 and the maximum value is the LOWER of the cooling and heating minimum values published in Table 7.

### Heating-to-cooling changeover:

Your unit will automatically change from heating to cooling mode when using a thermostat or sensor with an auto-change-over feature.

### Airflow:

All units are draw-through in cooling mode and blow-through in heating mode.

### Outdoor air application strategies:

Economizers reduce operating expenses and compressor run time by providing a free source of cooling and a means of ventilation to match application changing needs. In fact, they should be considered for most applications. Also, consider the various economizer control methods and their benefits, as well as sensors required to accomplish your application goals. Please contact your local Carrier representative for assistance.

### Motor limits, break horsepower (BHP):

Due to internal design of Carrier units, the air path, and specially designed motors, the full horsepower (maximum continuous BHP) band, as listed in Table 8, can be used with the utmost confidence. There is no need for extra safety factors, as Carrier motors are designed and rigorously tested to use the entire, listed BHP range without either nuisance tripping or premature motor failure.

### Propane heating:

Propane has different physical qualities than natural gas. As a result, Propane requires different fuel to air mixture. To optimize the fuel/air mixture for Propane, Carrier sells different burner orifices in an easy to install accessory kit. To select the correct burner orifices or determine the heat capacity for a Propane application, use either the selection software, or the unit's service manual.

### High altitude heating:

High altitudes have less oxygen, which affects the fuel/air mixture in heat exchangers. In order to maintain a proper fuel/air mixture, heat exchangers operating in altitudes above 2000 ft (610 m) require different orifices. To select the correct burner orifices or determine the heat capacity for a high altitude application, use either the selection software, or the unit's service manual.

High altitudes have less oxygen, which means heat exchangers need less fuel. The new gas orifices in this field-installed kit make the necessary adjustment for high altitude applications. They restore the optimal fuel to air mixture and maintain healthy combustion on altitudes above 2000 ft (610 m).

**NOTE:** Typical natural gas heating value ranges from 975 to 1050 Btu/ft<sup>3</sup> at sea level nationally. The heating value goes down approximately 1.7% per every thousand feet elevation. Standard factory orifices can typically be used up to 2000 ft (610m) elevation without any operational issues.

**NOTE:** For installations in Canada, the input rating should be derated by 10% for altitudes from 2000 ft (610m) to 4500 ft (1372m) above sea level.

## APPLICATION DATA (cont.)

### Sizing a rooftop

Bigger isn't necessarily better. While an air conditioner needs to have enough capacity to meet the design loads, it doesn't need excess capacity. In fact, excess capacity typically results in very poor part load performance and humidity control.

Using higher design temperatures than ASHRAE recommends for your location, adding "safety factors" to the calculated load, are all signs of oversizing air conditioners. Oversizing the air conditioner leads to poor humidity control, reduced efficiency, higher utility bills, larger indoor temperature swings, excessive noise, and increased wear and tear on the air conditioner.

Rather than oversizing an air conditioner, engineers should "right-size" or even slightly undersize air conditioners. Correctly sizing an air conditioner controls humidity better; promotes efficiency; reduces utility bills; extends equipment life, and maintains even, comfortable temperatures. Please contact your local Carrier representative for assistance.

### Low ambient applications

In low ambient applications where outside air might not be desired (such as contaminated or excessively humid outdoor environments), your Carrier rooftop can operate to ambient temperatures down to 10°F (-12°C) with electrical mechanical controls and down to 0°F (-18°C) with ComfortLink controls.

48LC



Climaproyectos  
.com

**Table 10 – COOLING CAPACITIES - FIRST STAGE, PART LOAD**

**3 TONS**

04 SIZE				AMBIENT TEMPERATURE																
				85			95			105			115			125				
				EA (dB)			EA (dB)			EA (dB)			EA (dB)			EA (dB)				
				75	80	85	75	80	85	75	80	85	75	80	85	75	80	85		
750 Cfm	EA (wB)	58	THC	24.1	24.1	27.3	22.8	22.8	25.9	21.4	21.4	24.3	19.9	19.9	22.6	18.2	18.2	20.7		
			SHC	20.9	24.1	27.3	19.7	22.8	25.9	18.5	21.4	24.3	17.1	19.9	22.6	15.6	18.2	20.7		
		62	THC	24.8	24.8	27.2	23.2	23.2	26.3	21.5	21.5	25.2	19.9	19.9	23.6	18.2	18.2	21.6		
			SHC	19.4	23.3	27.2	18.5	22.4	26.3	17.5	21.3	25.2	16.2	19.9	23.6	14.7	18.2	21.6		
		67	THC	27.5	27.5	27.5	25.7	25.7	25.7	23.9	23.9	23.9	21.9	21.9	21.9	19.7	19.7	19.8		
			SHC	15.7	19.7	23.7	14.9	18.8	22.8	13.9	17.9	21.8	13.0	16.9	20.9	11.9	15.9	19.8		
		72	THC	30.5	30.5	30.5	28.6	28.6	28.6	26.6	26.6	26.6	24.5	24.5	24.5	22.2	22.2	22.2		
			SHC	12.0	16.0	20.0	11.1	15.1	19.1	10.2	14.2	18.2	9.2	13.2	17.2	8.2	12.2	16.2		
		76	THC	-	33.0	33.0	-	31.0	31.0	-	28.9	28.9	-	26.7	26.7	-	24.2	24.2		
			SHC	-	12.9	17.0	-	12.1	16.1	-	11.2	15.2	-	10.2	14.2	-	9.2	13.2		
		900 Cfm	EA (wB)	58	THC	25.8	25.8	29.2	24.4	24.4	27.6	22.8	22.8	25.9	21.2	21.2	24.1	19.4	19.4	22.1
					SHC	22.4	25.8	29.2	21.1	24.4	27.6	19.7	22.8	25.9	18.3	21.2	24.1	16.7	19.4	22.1
				62	THC	25.8	25.8	30.4	24.4	24.4	28.7	22.9	22.9	27.0	21.2	21.2	25.1	19.4	19.4	23.0
					SHC	21.3	25.8	30.4	20.0	24.4	28.7	18.7	22.9	27.0	17.3	21.2	25.1	15.8	19.4	23.0
67	THC			28.4	28.4	28.4	26.6	26.6	26.6	24.6	24.6	24.6	22.5	22.5	23.6	20.3	20.3	22.5		
	SHC			17.1	21.8	26.5	16.2	20.9	25.6	15.2	19.9	24.6	14.2	18.9	23.6	13.2	17.8	22.5		
72	THC			31.4	31.4	31.4	29.4	29.4	29.4	27.4	27.4	27.4	25.2	25.2	25.2	22.7	22.7	22.7		
	SHC			12.6	17.3	22.1	11.7	16.4	21.2	10.8	15.5	20.2	9.8	14.5	19.2	8.8	13.5	18.2		
76	THC			-	34.0	34.0	-	31.9	31.9	-	29.7	29.7	-	27.4	27.4	-	24.8	24.8		
	SHC			-	13.7	18.5	-	12.8	17.6	-	11.9	16.7	-	10.9	15.7	-	9.9	14.6		
1050 Cfm	EA (wB)			58	THC	27.1	27.1	30.7	25.6	25.6	29.0	24.0	24.0	27.2	22.2	22.2	25.3	20.3	20.3	23.2
					SHC	23.6	27.1	30.7	22.2	25.6	29.0	20.8	24.0	27.2	19.2	22.2	25.3	17.5	20.3	23.2
				62	THC	27.1	27.1	31.9	25.6	25.6	30.2	24.0	24.0	28.3	22.3	22.3	26.3	20.3	20.3	24.1
					SHC	22.4	27.1	31.9	21.1	25.6	30.2	19.7	24.0	28.3	18.2	22.3	26.3	16.6	20.3	24.1
		67	THC	29.1	29.1	29.2	27.2	27.2	28.3	25.2	25.2	27.2	23.0	23.0	26.2	20.7	20.7	25.0		
			SHC	18.4	23.8	29.2	17.4	22.9	28.3	16.5	21.9	27.2	15.4	20.8	26.2	14.3	19.6	25.0		
		72	THC	32.1	32.1	32.1	30.1	30.1	30.1	27.9	27.9	27.9	25.6	25.6	25.6	23.2	23.2	23.2		
			SHC	13.2	18.6	24.1	12.3	17.7	23.1	11.3	16.8	22.2	10.3	15.8	21.2	9.3	14.7	20.1		
		76	THC	-	34.7	34.7	-	32.6	32.6	-	30.3	30.3	-	-	-	-	-	-		
			SHC	-	14.4	19.9	-	13.5	19.0	-	12.6	18.1	-	-	-	-	-	-		
		1200 Cfm	EA (wB)	58	THC	28.2	28.2	31.9	26.6	26.6	30.2	24.9	24.9	28.3	23.1	23.1	26.2	21.1	21.1	24.0
					SHC	24.5	28.2	31.9	23.1	26.6	30.2	21.6	24.9	28.3	20.0	23.1	26.2	18.2	21.1	24.0
				62	THC	28.2	28.2	33.2	26.7	26.7	31.4	24.9	24.9	29.4	23.1	23.1	27.3	21.1	21.1	25.0
					SHC	23.3	28.2	33.2	22.0	26.7	31.4	20.5	24.9	29.4	18.9	23.1	27.3	17.2	21.1	25.0
67	THC			29.6	29.6	31.8	27.7	27.7	30.8	25.6	25.6	29.7	23.5	23.5	28.5	21.2	21.2	27.0		
	SHC			19.6	25.7	31.8	18.6	24.7	30.8	17.6	23.7	29.7	16.5	22.5	28.5	15.3	21.2	27.0		
72	THC			32.6	32.6	32.6	30.6	30.6	30.6	28.4	28.4	28.4	26.0	26.0	26.0	23.5	23.5	23.5		
	SHC			13.7	19.8	26.0	12.8	18.9	25.1	11.8	18.0	24.1	10.8	16.9	23.1	9.8	15.9	22.0		
76	THC			-	35.2	35.2	-	33.1	33.1	-	-	-	-	-	-	-	-	-		
	SHC			-	15.1	21.3	-	14.1	20.3	-	-	-	-	-	-	-	-	-		
1350 Cfm	EA (wB)			58	THC	29.1	29.1	32.9	27.5	27.5	31.1	25.7	25.7	29.2	23.8	23.8	27.0	21.7	21.7	24.7
					SHC	25.3	29.1	32.9	23.9	27.5	31.1	22.3	25.7	29.2	20.6	23.8	27.0	18.7	21.7	24.7
				62	THC	29.2	29.2	34.2	27.5	27.5	32.4	25.8	25.8	30.3	23.8	23.8	28.1	21.8	21.8	25.8
					SHC	24.1	29.2	34.2	22.7	27.5	32.4	21.2	25.8	30.3	19.5	23.8	28.1	17.8	21.8	25.8
		67	THC	30.0	30.0	34.2	28.1	28.1	33.1	26.0	26.0	31.9	23.9	23.9	30.3	21.8	21.8	27.8		
			SHC	20.7	27.4	34.2	19.7	26.4	33.1	18.6	25.3	31.9	17.4	23.9	30.3	15.8	21.8	27.8		
		72	THC	33.0	33.0	33.0	30.9	30.9	30.9	28.7	28.7	28.7	26.3	26.3	26.3	23.7	23.7	23.8		
			SHC	14.2	21.0	27.9	13.2	20.1	26.9	12.3	19.1	26.0	11.3	18.1	24.9	10.2	17.0	23.8		
		76	THC	-	35.7	35.7	-	-	-	-	-	-	-	-	-	-	-	-		
			SHC	-	15.7	22.6	-	-	-	-	-	-	-	-	-	-	-	-		

**LEGEND:**

- Do not operate
- Cfm - Cubic feet per minute (supply air)
- EAT(db) - Entering air temperature (dry bulb)
- EAT(wb) - Entering air temperature (wet bulb)
- SHC - Sensible heat capacity
- TC - Total capacity



**Table 11 – COOLING CAPACITIES - SECOND STAGE, FULL LOAD**

**3 TONS**

04 SIZE				AMBIENT TEMPERATURE																
				85			95			105			115			125				
				EA (dB)			EA (dB)			EA (dB)			EA (dB)			EA (dB)				
				75	80	85	75	80	85	75	80	85	75	80	85	75	80	85		
900 Cfm	EA (wB)	58	THC	31.5	31.5	35.8	29.8	29.8	33.9	27.9	27.9	31.9	25.9	25.9	29.7	23.9	23.9	27.4		
			SHC	27.2	31.5	35.8	25.6	29.8	33.9	24	27.9	31.9	22.2	25.9	29.7	20.3	23.9	27.4		
		62	THC	33.4	33.4	34	31.3	31.3	32.7	29	29	31.3	26.6	26.6	29.8	24.1	24.1	28.2		
			SHC	24.6	29.3	34	23.3	28	32.7	21.9	26.6	31.3	20.5	25.1	29.8	19	23.6	28.2		
		67	THC	37.3	37.3	37.3	35	35	35	32.5	32.5	32.5	29.9	29.9	29.9	27.2	27.2	27.2		
			SHC	20.3	25	29.8	19	23.7	28.5	17.7	22.4	27.1	16.3	21	25.7	14.8	19.6	24.3		
		72	THC	41.5	41.5	41.5	39	39	39	36.3	36.3	36.3	33.6	33.6	33.6	30.6	30.6	30.6		
			SHC	15.9	20.7	25.5	14.6	19.4	24.2	13.3	18.1	22.8	11.9	16.7	21.4	10.5	15.2	20		
		76	THC	-	45	45	-	42.4	42.4	-	39.6	39.6	-	36.7	36.7	-	33.5	33.5		
			SHC	-	17.1	22.1	-	15.8	20.8	-	14.5	19.5	-	13.2	18.1	-	11.7	16.6		
		1050 Cfm	EA (wB)	58	THC	33.6	33.6	38.1	31.7	31.7	36	29.7	29.7	33.9	27.6	27.6	31.6	25.4	25.4	29.1
					SHC	29	33.6	38.1	27.4	31.7	36	25.6	29.7	33.9	23.7	27.6	31.6	21.7	25.4	29.1
				62	THC	34.7	34.7	37.5	32.5	32.5	36.1	30.1	30.1	34.6	27.7	27.7	33	25.4	25.4	30.4
					SHC	26.7	32.1	37.5	25.4	30.7	36.1	23.9	29.3	34.6	22.4	27.7	33	20.4	25.4	30.4
67	THC			38.6	38.6	38.6	36.1	36.1	36.1	33.6	33.6	33.6	30.9	30.9	30.9	28	28	28		
	SHC			21.8	27.2	32.7	20.4	25.9	31.4	19.1	24.5	30	17.7	23.1	28.6	16.2	21.6	27.1		
72	THC			42.8	42.8	42.8	40.2	40.2	40.2	37.5	37.5	37.5	34.6	34.6	34.6	31.5	31.5	31.5		
	SHC			16.6	22.1	27.6	15.3	20.8	26.3	14	19.5	24.9	12.6	18	23.5	11.1	16.6	22.1		
76	THC			-	46.4	46.4	-	43.6	43.6	-	40.7	40.7	-	37.7	37.7	-	34.4	34.4		
	SHC			-	18	23.7	-	16.7	22.3	-	15.3	21	-	13.9	19.5	-	12.5	18.1		
1200 Cfm	EA (wB)			58	THC	35.3	35.3	40	33.3	33.3	37.9	31.3	31.3	35.6	29	29	33.2	26.7	26.7	30.6
					SHC	30.6	35.3	40	28.8	33.3	37.9	26.9	31.3	35.6	24.9	29	33.2	22.8	26.7	30.6
				62	THC	35.8	35.8	40.8	33.6	33.6	39.1	31.3	31.3	37.1	29.1	29.1	34.6	26.7	26.7	31.9
					SHC	28.7	34.7	40.8	27.2	33.2	39.1	25.5	31.3	37.1	23.6	29.1	34.6	21.5	26.7	31.9
		67	THC	39.6	39.6	39.6	37	37	37	34.4	34.4	34.4	31.6	31.6	31.6	28.6	28.6	29.7		
			SHC	23.1	29.3	35.5	21.8	27.9	34.1	20.4	26.6	32.7	18.9	25.1	31.3	17.4	23.6	29.7		
		72	THC	43.9	43.9	43.9	41.2	41.2	41.2	38.3	38.3	38.3	35.3	35.3	35.3	32.1	32.1	32.1		
			SHC	17.3	23.5	29.7	15.9	22.2	28.4	14.6	20.8	27	13.1	19.3	25.5	11.7	17.9	24		
		76	THC	-	47.5	47.5	-	44.6	44.6	-	41.6	41.6	-	38.4	38.4	-	35.1	35.1		
			SHC	-	18.8	25.2	-	17.4	23.8	-	16.1	22.4	-	14.7	21	-	13.2	19.5		
		1350 Cfm	EA (wB)	58	THC	36.8	36.8	41.7	34.7	34.7	39.4	32.5	32.5	37	30.2	30.2	34.5	27.8	27.8	31.8
					SHC	31.9	36.8	41.7	30	34.7	39.4	28.1	32.5	37	26	30.2	34.5	23.8	27.8	31.8
				62	THC	36.8	36.8	43.4	34.8	34.8	41	32.6	32.6	38.6	30.3	30.3	36	27.8	27.8	33.2
					SHC	30.3	36.8	43.4	28.5	34.8	41	26.6	32.6	38.6	24.6	30.3	36	22.5	27.8	33.2
67	THC			40.4	40.4	40.4	37.8	37.8	37.8	35	35	35.4	32.2	32.2	33.9	29.2	29.2	32.3		
	SHC			24.4	31.3	38.2	23	29.9	36.8	21.6	28.5	35.4	20.2	27	33.9	18.6	25.4	32.3		
72	THC			44.7	44.7	44.7	41.9	41.9	41.9	39	39	39	35.9	35.9	35.9	32.7	32.7	32.7		
	SHC			17.9	24.8	31.7	16.5	23.4	30.3	15.1	22	28.9	13.7	20.6	27.5	12.2	19.1	26		
76	THC			-	48.3	48.3	-	45.4	45.4	-	42.3	42.3	-	39.1	39.1	-	35.6	35.6		
	SHC			-	19.5	26.6	-	18.1	25.2	-	16.8	23.8	-	15.3	22.3	-	13.8	20.8		
1500 Cfm	EA (wB)			58	THC	38.1	38.1	43.1	35.9	35.9	40.8	33.7	33.7	38.3	31.3	31.3	35.6	28.7	28.7	32.8
					SHC	33	38.1	43.1	31.1	35.9	40.8	29	33.7	38.3	26.9	31.3	35.6	24.6	28.7	32.8
				62	THC	38.1	38.1	44.8	36	36	42.4	33.7	33.7	39.9	31.3	31.3	37.1	28.7	28.7	34.2
					SHC	31.4	38.1	44.8	29.5	36	42.4	27.5	33.7	39.9	25.5	31.3	37.1	23.2	28.7	34.2
		67	THC	41	41	41	38.4	38.4	39.3	35.6	35.6	37.9	32.7	32.7	36.3	29.6	29.6	34.6		
			SHC	25.6	33.2	40.8	24.2	31.8	39.3	22.8	30.3	37.9	21.3	28.8	36.3	19.7	27.2	34.6		
		72	THC	45.4	45.4	45.4	42.5	42.5	42.5	39.5	39.5	39.5	36.4	36.4	36.4	33.1	33.1	33.1		
			SHC	18.4	26	33.6	17	24.6	32.2	15.6	23.2	30.8	14.2	21.8	29.3	12.7	20.2	27.8		
		76	THC	-	49	49	-	46	46	-	42.9	42.9	-	39.6	39.6	-	36	36		
			SHC	-	20.2	27.9	-	18.8	26.5	-	17.4	25.1	-	16	23.6	-	14.5	22.1		

**LEGEND:**

- Do not operate
- Cfm - Cubic feet per minute (supply air)
- EAT(db) - Entering air temperature (dry bulb)
- EAT(wb) - Entering air temperature (wet bulb)
- SHC - Sensible heat capacity
- TC - Total capacity

**48LC**



Table 12 – COOLING CAPACITIES

3 TONS

48LC

48LC04 (3 TONS) - UNIT WITH HUMIDI- MIZER SYSTEM IN SUBCOOLING MODE										
Temp (F) Air Entering Condenser (Edb)		AIR ENTERING EVAPORATOR - CFM/BF								
		900			1,200			1,500		
		Air Entering Evaporator - Ewb (F)								
		72	67	62	72	67	62	72	67	62
75	TC	41.2	37.0	32.8	45.5	40.8	36.1	49.3	44.1	39.0
	SHC	19.5	22.6	25.6	23.3	26.8	30.2	26.6	30.5	33.7
	kW	1.90	1.88	1.84	1.94	1.90	1.87	1.96	1.90	1.89
85	TC	38.3	34.1	30.0	42.0	37.3	32.6	45.2	40.1	35.0
	SHC	16.1	20.0	23.9	19.4	23.9	28.2	22.4	27.3	31.5
	kW	2.19	2.15	2.11	2.22	2.18	2.14	2.24	2.20	2.16
95	TC	35.4	31.2	27.0	38.4	33.8	29.2	41.1	36.1	31.0
	SHC	12.7	17.4	22.1	15.6	21.0	26.3	18.2	24.2	29.0
	kW	2.47	2.42	2.38	2.50	2.46	2.41	2.53	2.48	2.43
105	TC	32.4	28.3	24.1	34.9	30.3	25.7	37.0	32.0	27.0
	SHC	9.3	14.8	20.4	11.8	18.1	24.1	14.0	21.1	26.5
	kW	2.75	2.70	2.65	2.79	2.73	2.68	2.82	2.76	2.71
115	TC	29.5	25.4	21.2	31.3	26.7	22.2	32.9	28.0	23.0
	SHC	5.9	12.3	18.6	8.0	15.3	21.8	9.8	17.9	22.7
	kW	3.03	2.97	2.91	3.07	3.01	2.95	3.10	3.04	2.98
125	TC	26.5	22.4	18.3	27.7	23.2	18.7	28.8	23.9	19.0
	SHC	2.5	9.7	16.9	4.2	12.4	18.3	5.6	14.8	18.9
	kW	3.31	3.25	3.18	3.36	3.29	3.22	3.39	3.32	3.25

48LC04 (3 TONS) - UNIT WITH HUMIDI- MIZER SYSTEM IN HOT GAS REHEAT MODE										
TEMP (F) AIR ENT CONDENSER (Edb)		AIR ENTERING EVAPORATOR - Ewb (F)								
		75 Dry Bulb 62.5 Wet Bulb (50% Relative)			75 Dry Bulb 64 Wet Bulb (56% Relative)			75 Dry Bulb 65.3 Wet Bulb (60% Relative)		
		Air Entering Evaporator - Cfm								
		900	1,200	1,500	900	1,200	1,500	900	1,200	1,500
80	TC	7.24	7.73	8.15	8.06	8.64	9.13	8.77	9.43	9.98
	SHC	1.47	1.90	2.27	1.65	2.10	2.50	1.80	2.23	2.70
	kW	2.44	2.47	2.49	2.45	2.49	2.52	2.48	2.52	2.54
75	TC	8.82	9.50	10.09	9.64	10.41	11.06	10.35	11.19	11.91
	SHC	2.24	2.76	3.20	2.43	2.97	3.44	2.58	3.16	3.65
	kW	2.33	2.36	2.39	2.34	2.38	2.41	2.37	2.40	2.43
70	TC	10.39	11.27	12.02	11.21	12.17	13.00	11.92	12.95	13.84
	SHC	3.01	3.61	4.14	3.21	3.84	4.39	3.37	4.03	4.60
	kW	2.22	2.25	2.28	2.23	2.27	2.29	2.26	2.29	2.32
60	TC	13.55	14.81	15.88	14.36	15.71	16.85	15.06	16.48	17.69
	SHC	4.55	5.33	5.99	4.77	5.57	6.27	4.95	5.79	6.51
	kW	2.00	2.03	2.05	2.01	2.05	2.07	2.04	2.07	2.09

**LEGEND**

- Edb - Entering Dry- Bulb
- Ewb - Entering Wet- Bulb
- kW - Compressor Motor Power Input
- ldb - Leaving Dry- Bulb
- lwb - Leaving Wet- Bulb
- SHC - Sensible Heat Capacity (1000 Btuh) Gross
- TC - Total Capacity (1000 Btuh) Gross

**NOTES:**

- 1 Direct interpolation is permissible. Do not extrapolate.
- 2 The following formulas may be used:

$$t_{ldb} = t_{edb} - \frac{\text{sensible capacity (Btuh)}}{1.10 \times \text{cfm}}$$

$t_{lwb}$  = Wet- bulb temperature corresponding to enthalpy of air leaving evaporator coil ( $h_{lwb}$ )

$$h_{lwb} = h_{ewb} - \frac{\text{total capacity (Btuh)}}{4.5 \times \text{cfm}}$$

Where:  $h_{ewb}$  = Enthalpy of air entering evaporator coil

**Table 13 – COOLING CAPACITIES - FIRST STAGE PART LOAD**

**4 TONS**

05 SIZE				AMBIENT TEMPERATURE																
				85			95			105			115			125				
				EA (dB)			EA (dB)			EA (dB)			EA (dB)			EA (dB)				
				75	80	85	75	80	85	75	80	85	75	80	85	75	80	85		
1000 Cfm	EA (wB)	58	THC	32.0	32.0	36.3	30.5	30.5	34.6	28.8	28.8	32.7	26.9	26.9	30.6	24.8	24.8	28.3		
			SHC	27.8	32.0	36.3	26.4	30.5	34.6	24.9	28.8	32.7	23.2	26.9	30.6	21.4	24.8	28.3		
		62	THC	33.2	33.2	35.6	31.3	31.3	34.5	29.3	29.3	33.2	27.1	27.1	31.7	24.9	24.9	29.5		
			SHC	25.6	30.6	35.6	24.5	29.5	34.5	23.3	28.2	33.2	21.9	26.8	31.7	20.3	24.9	29.5		
		67	THC	36.9	36.9	36.9	34.8	34.8	34.8	32.6	32.6	32.6	30.1	30.1	30.1	27.4	27.4	27.4		
			SHC	21.0	26.0	31.1	19.9	25.0	30.0	18.8	23.8	28.9	17.6	22.6	27.6	16.3	21.3	26.3		
		72	THC	41.0	41.0	41.0	38.7	38.7	38.7	36.3	36.3	36.3	33.7	33.7	33.7	30.8	30.8	30.8		
			SHC	16.2	21.3	26.4	15.1	20.2	25.3	14.0	19.1	24.2	12.9	17.9	23.0	11.6	16.6	21.7		
		76	THC	-	44.4	44.4	-	42.1	42.1	-	39.5	39.5	-	36.7	36.7	-	33.6	33.6		
			SHC	-	17.4	22.8	-	16.4	21.7	-	15.3	20.6	-	14.1	19.3	-	12.9	18.0		
		1200 Cfm	EA (wB)	58	THC	34.2	34.2	38.7	32.6	32.6	36.9	30.7	30.7	34.8	28.7	28.7	32.6	26.5	26.5	30.1
					SHC	29.7	34.2	38.7	28.2	32.6	36.9	26.6	30.7	34.8	24.8	28.7	32.6	22.8	26.5	30.1
				62	THC	34.6	34.6	39.6	32.6	32.6	38.4	30.8	30.8	36.3	28.7	28.7	33.9	26.5	26.5	31.4
					SHC	28.0	33.8	39.6	26.9	32.6	38.4	25.3	30.8	36.3	23.5	28.7	33.9	21.6	26.5	31.4
67	THC			38.2	38.2	38.2	36.0	36.0	36.0	33.7	33.7	33.7	31.1	31.1	31.1	28.2	28.2	29.6		
	SHC			22.7	28.6	34.6	21.6	27.5	33.5	20.4	26.4	32.3	19.2	25.1	31.0	17.8	23.7	29.6		
72	THC			42.3	42.3	42.3	40.0	40.0	40.0	37.5	37.5	37.5	34.7	34.7	34.7	31.7	31.7	31.7		
	SHC			17.0	23.0	29.0	15.9	21.9	27.9	14.8	20.7	26.7	13.6	19.5	25.5	12.3	18.2	24.1		
76	THC			-	45.8	45.8	-	43.4	43.4	-	40.7	40.7	-	37.7	37.7	-	34.5	34.5		
	SHC			-	18.4	24.6	-	17.3	23.5	-	16.2	22.3	-	15.0	21.1	-	13.7	19.7		
1400 Cfm	EA (wB)			58	THC	36.0	36.0	40.7	34.2	34.2	38.7	32.3	32.3	36.6	30.1	30.1	34.2	27.8	27.8	31.6
					SHC	31.3	36.0	40.7	29.7	34.2	38.7	28.0	32.3	36.6	26.1	30.1	34.2	24.0	27.8	31.6
				62	THC	36.0	36.0	42.3	34.3	34.3	40.3	32.3	32.3	38.1	30.2	30.2	35.6	27.8	27.8	32.9
					SHC	29.8	36.0	42.3	28.2	34.3	40.3	26.6	32.3	38.1	24.7	30.2	35.6	22.7	27.8	32.9
		67	THC	39.1	39.1	39.1	36.9	36.9	36.9	34.5	34.5	35.5	31.8	31.8	34.2	28.9	28.9	32.7		
			SHC	24.2	31.1	37.9	23.1	29.9	36.8	21.9	28.7	35.5	20.7	27.4	34.2	19.3	26.0	32.7		
		72	THC	43.3	43.3	43.3	40.9	40.9	40.9	38.3	38.3	38.3	35.5	35.5	35.5	32.3	32.3	32.3		
			SHC	17.7	24.5	31.4	16.6	23.4	30.3	15.5	22.3	29.1	14.2	21.0	27.8	12.9	19.7	26.4		
		76	THC	-	46.9	46.9	-	44.3	44.3	-	41.5	41.5	-	38.5	38.5	-	35.2	35.2		
			SHC	-	19.3	26.3	-	18.2	25.2	-	17.0	24.0	-	15.8	22.7	-	14.5	21.3		
		1600 Cfm	EA (wB)	58	THC	37.5	37.5	42.3	35.6	35.6	40.3	33.6	33.6	38.0	31.3	31.3	35.5	28.9	28.9	32.8
					SHC	32.6	37.5	42.3	30.9	35.6	40.3	29.1	33.6	38.0	27.1	31.3	35.5	24.9	28.9	32.8
				62	THC	37.5	37.5	44.0	35.6	35.6	41.9	33.6	33.6	39.6	31.4	31.4	37.0	28.9	28.9	34.2
					SHC	31.0	37.5	44.0	29.4	35.6	41.9	27.6	33.6	39.6	25.7	31.4	37.0	23.6	28.9	34.2
67	THC			39.9	39.9	41.0	37.6	37.6	39.8	35.1	35.1	38.5	32.4	32.4	37.1	29.4	29.4	35.4		
	SHC			25.7	33.4	41.0	24.6	32.2	39.8	23.3	30.9	38.5	22.0	29.5	37.1	20.5	28.0	35.4		
72	THC			44.1	44.1	44.1	41.6	41.6	41.6	39.0	39.0	39.0	36.0	36.0	36.0	32.8	32.8	32.8		
	SHC			18.3	26.0	33.7	17.2	24.9	32.5	16.1	23.7	31.3	14.8	22.4	30.0	13.5	21.1	28.6		
76	THC			-	47.7	47.7	-	45.1	45.1	-	42.2	42.2	-	39.1	39.1	-	35.7	35.7		
	SHC			-	20.1	27.9	-	19.0	26.7	-	17.8	25.5	-	16.5	24.2	-	15.2	22.8		
1800 Cfm	EA (wB)			58	THC	38.7	38.7	43.7	36.8	36.8	41.6	34.7	34.7	39.2	32.3	32.3	36.7	29.8	29.8	33.8
					SHC	33.7	38.7	43.7	31.9	36.8	41.6	30.1	34.7	39.2	28.0	32.3	36.7	25.7	29.8	33.8
				62	THC	38.7	38.7	45.4	36.8	36.8	43.2	34.7	34.7	40.8	32.4	32.4	38.2	29.8	29.8	35.2
					SHC	32.0	38.7	45.4	30.4	36.8	43.2	28.5	34.7	40.8	26.6	32.4	38.2	24.4	29.8	35.2
		67	THC	40.5	40.5	44.0	38.1	38.1	42.7	35.6	35.6	41.3	32.9	32.9	39.7	30.0	30.0	37.6		
			SHC	27.1	35.5	44.0	25.9	34.3	42.7	24.6	33.0	41.3	23.2	31.5	39.7	21.6	29.6	37.6		
		72	THC	44.7	44.7	44.7	42.2	42.2	42.2	39.5	39.5	39.5	36.5	36.5	36.5	33.2	33.2	33.2		
			SHC	18.9	27.4	35.9	17.8	26.3	34.8	16.6	25.1	33.5	15.4	23.8	32.2	14.0	22.4	30.8		
		76	THC	-	48.4	48.4	-	45.6	45.6	-	42.7	42.7	-	39.5	39.5	-	36.1	36.1		
			SHC	-	20.8	29.4	-	19.7	28.2	-	18.5	27.0	-	17.2	25.6	-	15.8	24.1		

**LEGEND:**

- Do not operate
- Cfm - Cubic feet per minute (supply air)
- EAT(db) - Entering air temperature (dry bulb)
- EAT(wb) - Entering air temperature (wet bulb)
- SHC - Sensible heat capacity
- TC - Total capacity

**48LC**

**S**

**m**

**Table 14 – COOLING CAPACITIES - SECOND STAGE FULL LOAD**

**4 TONS**

05 SIZE				AMBIENT TEMPERATURE															
				85			95			105			115			125			
				EA (dB)			EA (dB)			EA (dB)			EA (dB)			EA (dB)			
				75	80	85	75	80	85	75	80	85	75	80	85	75	80	85	
1200 Cfm	EA (wB)	58	THC	42.0	42.0	47.6	39.8	39.8	45.2	37.5	37.5	42.6	35.0	35.0	39.9	32.5	32.5	37.1	
			SHC	36.4	42.0	47.6	34.4	39.8	45.2	32.3	37.5	42.6	30.1	35.0	39.9	27.8	32.5	37.1	
		62	THC	44.7	44.7	44.7	42.0	42.0	43.1	39.1	39.1	41.4	36.1	36.1	39.6	33.0	33.0	37.7	
			SHC	32.7	38.7	44.7	31.1	37.1	43.1	29.4	35.4	41.4	27.7	33.7	39.6	25.9	31.8	37.7	
		67	THC	49.4	49.4	49.4	46.5	46.5	46.5	43.4	43.4	43.4	40.2	40.2	40.2	36.8	36.8	36.8	
			SHC	27	33.1	39.1	25.5	31.5	37.5	23.8	29.9	35.9	22.2	28.2	34.2	20.4	26.5	32.5	
	72	THC	54.5	54.5	54.5	51.4	51.4	51.4	48.1	48.1	48.1	44.6	44.6	44.6	41.0	41.0	41.0		
		SHC	21.2	27.4	33.5	19.7	25.8	31.9	18.1	24.2	30.3	16.4	22.5	28.6	14.7	20.8	26.9		
	76	THC	-	58.8	58.8	-	55.4	55.4	-	51.9	51.9	-	48.2	48.2	-	44.4	44.4		
		SHC	-	22.7	29.3	-	21.1	27.7	-	19.6	26.1	-	17.9	24.4	-	16.2	22.6		
	1400 Cfm	EA (wB)	58	THC	44.5	44.5	50.4	42.1	42.1	47.8	39.7	39.7	45.1	37.1	37.1	42.2	34.3	34.3	39.2
				SHC	38.6	44.5	50.4	36.5	42.1	47.8	34.3	39.7	45.1	31.9	37.1	42.2	29.5	34.3	39.2
62			THC	46.3	46.3	49.1	43.4	43.4	47.3	40.5	40.5	45.5	37.4	37.4	43.4	34.4	34.4	40.9	
			SHC	35.3	42.2	49.1	33.6	40.5	47.3	31.9	38.7	45.5	30.0	36.7	43.4	27.9	34.4	40.9	
67			THC	51.0	51.0	51.0	48.0	48	48.0	44.7	44.7	44.7	41.4	41.4	41.4	37.8	37.8	37.8	
			SHC	28.8	35.7	42.7	27.2	34.1	41.1	25.5	32.5	39.4	23.8	30.7	37.7	22.1	29.0	35.9	
72		THC	56.2	56.2	56.2	52.9	52.9	52.9	49.4	49.4	49.4	45.8	45.8	45.8	42.0	42.0	42.0		
		SHC	22.1	29.1	36.1	20.5	27.5	34.5	18.9	25.8	32.8	17.2	24.1	31.1	15.5	22.4	29.3		
76		THC	-	60.4	60.4	-	56.9	56.9	-	53.3	53.3	-	49.4	49.4	-	45.4	45.4		
		SHC	-	23.7	31.2	-	22.1	29.5	-	20.5	27.8	-	18.8	26.1	-	17.1	24.3		
1600 Cfm		EA (wB)	58	THC	46.6	46.6	52.7	44.1	44.1	50.0	41.5	41.5	47.2	38.8	38.8	44.1	35.9	35.9	40.9
				SHC	40.4	46.6	52.7	38.2	44.1	50.0	35.9	41.5	47.2	33.4	38.8	44.1	30.8	35.9	40.9
	62		THC	47.6	47.6	53.0	44.7	44.7	51.1	41.6	41.6	49.2	38.8	38.8	46.0	35.9	35.9	42.7	
			SHC	37.7	45.3	53.0	35.9	43.5	51.1	34.1	41.6	49.2	31.7	38.8	46.0	29.2	35.9	42.7	
	67		THC	52.3	52.3	52.3	49.1	49.1	49.1	45.8	45.8	45.8	42.3	42.3	42.3	38.6	38.6	39.1	
			SHC	30.4	38.3	46.1	28.8	36.6	44.4	27.1	34.9	42.7	25.4	33.2	40.9	23.6	31.3	39.1	
	72	THC	57.4	57.4	57.4	54.0	54.0	54.0	50.5	50.5	50.5	46.7	46.7	46.7	42.8	42.8	42.8		
		SHC	22.8	30.7	38.6	21.2	29.1	36.9	19.6	27.4	35.2	17.9	25.7	33.5	16.1	23.9	31.7		
	76	THC	-	61.7	61.7	-	58.1	58.1	-	54.3	54.3	-	50.3	50.3	-	46.2	46.2		
		SHC	-	24.6	32.9	-	23	31.2	-	21.4	29.5	-	19.7	27.7	-	17.9	25.9		
	1800 Cfm	EA (wB)	58	THC	48.4	48.4	54.7	45.8	45.8	51.9	43.1	43.1	48.9	40.2	40.2	45.7	37.2	37.2	42.4
				SHC	42.0	48.4	54.7	39.7	45.8	51.9	37.3	43.1	48.9	34.7	40.2	45.7	32.0	37.2	42.4
62			THC	48.8	48.8	56.4	45.9	45.9	54.0	43.1	43.1	50.9	40.2	40.2	47.6	37.2	37.2	44.2	
			SHC	39.7	48.1	56.4	37.7	45.9	54.0	35.4	43.1	50.9	32.9	40.2	47.6	30.3	37.2	44.2	
67			THC	53.3	53.3	53.3	50.0	50	50.0	46.6	46.6	46.6	43.0	43.0	44.1	39.2	39.2	42.1	
			SHC	32	40.7	49.3	30.3	39.0	47.7	28.6	37.3	45.9	26.8	35.5	44.1	25	33.6	42.1	
72		THC	58.5	58.5	58.5	55.0	55.0	55.0	51.3	51.3	51.3	47.5	47.5	47.5	43.4	43.4	43.4		
		SHC	23.5	32.2	41.0	21.9	30.6	39.3	20.2	28.9	37.6	18.5	27.1	35.8	16.7	25.3	33.9		
76		THC	-	62.8	62.8	-	59.0	59.0	-	55.1	55.1	-	51.1	51.1	-	46.9	46.9		
		SHC	-	25.5	34.5	-	23.8	32.8	-	22.2	31.1	-	20.4	29.3	-	18.6	27.4		
2000 Cfm		EA (wB)	58	THC	49.9	49.9	56.5	47.2	47.2	53.5	44.4	44.4	50.4	41.4	41.4	47.1	38.3	38.3	43.6
				SHC	43.4	49.9	56.5	41.0	47.2	53.5	38.4	44.4	50.4	35.8	41.4	47.1	33.0	38.3	43.6
	62		THC	50.0	50.0	58.7	47.3	47.3	55.7	44.5	44.5	52.4	41.5	41.5	49.0	38.3	38.3	45.5	
			SHC	41.2	50.0	58.7	38.9	47.3	55.7	36.5	44.5	52.4	33.9	41.5	49.0	31.2	38.3	45.5	
	67		THC	54.1	54.1	54.1	50.7	50.7	50.7	47.2	47.2	48.9	43.5	43.5	47.0	39.7	39.7	45.0	
			SHC	33.4	42.9	52.4	31.8	41.2	50.7	30	39.5	48.9	28.2	37.6	47.0	26.3	35.6	45.0	
	72	THC	59.3	59.3	59.3	55.7	55.7	55.7	52.0	52.0	52.0	48.0	48.0	48.0	43.9	43.9	43.9		
		SHC	24.2	33.7	43.2	22.5	32.0	41.5	20.8	30.3	39.8	19.1	28.5	37.9	17.3	26.7	36.0		
	76	THC	-	63.6	63.6	-	59.8	59.8	-	55.8	55.8	-	51.6	51.6	-	47.4	47.4		
		SHC	-	26.3	36.1	-	24.6	34.4	-	22.9	32.6	-	21.1	30.7	-	19.3	28.8		

**LEGEND:**

- Do not operate
- Cfm - Cubic feet per minute (supply air)
- EAT(db) - Entering air temperature (dry bulb)
- EAT(wb) - Entering air temperature (wet bulb)
- SHC - Sensible heat capacity
- TC - Total capacity

Table 15 – COOLING CAPACITIES

4 TONS

48LC05 (4 TONS) - UNIT WITH HUMIDI- MIZER SYSTEM IN SUBCOOLING MODE										
TEMP (F) AIR ENT CON- DENSER (Edb)		AIR ENTERING EVAPORATOR - CFM/BF								
		1,200			1,600			2,000		
		Air Entering Evaporator - - Ewb (F)								
		72	67	62	72	67	62	72	67	62
75	TC	54.6	49.4	44.3	59.4	53.6	47.9	63.5	57.3	51.2
	SHC	23.6	28.3	33.0	28.0	33.5	40.1	31.8	38.1	44.3
	kW	2.39	2.36	2.32	2.41	2.38	2.34	2.43	2.39	2.36
85	TC	50.7	45.6	40.5	54.5	48.9	43.3	57.8	51.8	45.8
	SHC	19.2	25.1	30.9	22.9	29.7	37.5	26.2	33.9	41.2
	kW	2.75	2.71	2.67	2.77	2.73	2.69	2.79	2.75	2.71
95	TC	46.8	41.7	36.7	49.6	44.2	38.7	52.1	46.3	40.4
	SHC	14.8	21.8	28.8	17.8	25.9	34.8	20.5	29.7	37.9
	kW	3.11	3.06	3.01	3.14	3.09	3.04	3.16	3.11	3.07
105	TC	42.8	37.9	32.9	44.7	39.4	34.1	46.4	40.8	35.1
	SHC	10.4	18.6	26.7	12.7	22.2	31.9	14.8	25.5	34.5
	kW	3.47	3.42	3.36	3.50	3.45	3.39	3.53	3.47	3.77
115	TC	38.9	34.0	29.2	39.9	34.7	29.5	40.8	35.2	29.7
	SHC	6.0	15.3	24.6	7.6	18.5	29.0	9.0	21.3	29.3
	kW	3.83	3.77	3.70	3.87	3.80	3.74	3.89	3.83	3.77
125	TC	34.9	30.2	25.5	35.0	29.9	24.9	35.1	29.7	24.3
	SHC	1.6	12.1	22.5	2.5	14.7	24.5	3.3	17.1	24.2
	kW	4.19	4.12	4.05	4.23	4.16	4.09	4.26	4.19	4.12

48LC

48LC05 (4 TONS) - UNIT WITH HUMIDI- MIZER SYSTEM IN HOT GAS REHEAT MODE										
TEMP (F) AIR ENT CONDENSER (Edb)		AIR ENTERING EVAPORATOR - Ewb (F)								
		75 Dry Bulb 62.5 Wet Bulb (50% Relative)			75 Dry Bulb 64 Wet Bulb (56% Relative)			75 Dry Bulb 65.3 Wet Bulb (60% Relative)		
		Air Entering Evaporator - Cfm								
		1,200	1,600	2,000	1,200	1,600	2,000	1,200	1,500	2,000
80	TC	9.51	10.01	10.48	9.94	10.56	11.13	10.32	11.04	11.69
	SHC	2.61	3.30	3.92	2.45	3.11	3.71	2.30	2.95	3.52
	kW	1.92	1.90	1.89	1.93	1.91	1.90	1.94	1.92	1.91
75	TC	10.86	11.70	12.45	11.31	12.27	13.13	11.71	12.76	13.71
	SHC	2.96	3.69	4.36	2.82	3.52	4.15	2.69	3.38	3.99
	kW	1.86	1.84	1.83	1.87	1.85	1.84	1.88	1.86	1.85
70	TC	12.22	13.38	14.43	12.69	13.97	15.13	13.10	14.48	15.73
	SHC	3.31	4.07	4.75	3.18	3.93	4.60	3.08	3.81	4.47
	kW	1.79	1.78	1.76	1.80	1.79	1.77	1.81	1.80	1.78
60	TC	14.93	16.74	18.38	15.45	17.38	19.12	15.89	17.93	19.77
	SHC	3.99	4.84	5.59	3.92	4.75	5.49	3.85	4.68	5.41
	kW	1.66	1.65	1.64	1.68	1.66	1.65	1.69	1.67	1.66

**LEGEND**

- Edb - Entering Dry- Bulb
- Ewb - Entering Wet- Bulb
- kW - Compressor Motor Power Input
- ldb - Leaving Dry- Bulb
- lwb - Leaving Wet- Bulb
- SHC - Sensible Heat Capacity (1000 Btuh) Gross
- TC - Total Capacity (1000 Btuh) Gross

**NOTES:**

- 1 Direct interpolation is permissible. Do not extrapolate.
- 2 The following formulas may be used:

$$t_{ldb} = t_{edb} - \frac{\text{sensible capacity (Btuh)}}{1.10 \times \text{cfm}}$$

$t_{lwb}$  = Wet- bulb temperature corresponding to enthalpy of air leaving evaporator coil ( $h_{lwb}$ )

$$h_{lwb} = h_{ewb} - \frac{\text{total capacity (Btuh)}}{4.5 \times \text{cfm}}$$

Where:  $h_{ewb}$  = Enthalpy of air entering evaporator coil

**Table 16 – COOLING CAPACITIES - FIRST STAGE PART LOAD**

**5 TONS**

06 SIZE				AMBIENT TEMPERATURE																
				85			95			105			115			125				
				EA (dB)			EA (dB)			EA (dB)			EA (dB)			EA (dB)				
				75	80	85	75	80	85	75	80	85	75	80	85	75	80	85		
1250 Cfm	EA (wB)	58	THC	40.1	40.1	45.4	38.0	38.0	43.1	35.7	35.7	40.6	33.1	33.1	37.8	30.3	30.3	34.7		
			SHC	34.8	40.1	45.4	32.8	38.0	43.1	30.8	35.7	40.6	28.5	33.1	37.8	26.0	30.3	34.7		
		62	THC	40.9	40.9	45.8	38.4	38.4	44.2	35.8	35.8	42.2	33.2	33.2	39.4	30.4	30.4	36.2		
			SHC	32.4	39.1	45.8	30.9	37.5	44.2	29.1	35.6	42.2	27.0	33.2	39.4	24.6	30.4	36.2		
		67	THC	45.4	45.4	45.4	42.6	42.6	42.6	39.6	39.6	39.6	36.3	36.3	36.3	32.8	32.8	33.3		
			SHC	26.2	32.9	39.7	24.8	31.5	38.3	23.2	30.0	36.7	21.6	28.3	35.1	19.9	26.6	33.3		
		72	THC	50.4	50.4	50.4	47.5	47.5	47.5	44.3	44.3	44.3	40.8	40.8	40.8	37.0	37.0	37.0		
			SHC	19.8	26.6	33.4	18.4	25.2	32.0	16.9	23.7	30.5	15.3	22.1	28.9	13.6	20.4	27.2		
		76	THC	-	54.8	54.8	-	51.7	51.7	-	48.3	48.3	-	44.6	44.6	-	40.6	40.6		
			SHC	-	21.5	28.4	-	20.1	27.0	-	18.6	25.4	-	17.0	23.8	-	15.3	22.1		
		1500 Cfm	EA (wB)	58	THC	42.9	42.9	48.6	40.6	40.6	46.1	38.1	38.1	43.3	35.4	35.4	40.3	32.4	32.4	37.0
					SHC	37.2	42.9	48.6	35.2	40.6	46.1	32.9	38.1	43.3	30.5	35.4	40.3	27.8	32.4	37.0
				62	THC	43.0	43.0	50.5	40.7	40.7	48.0	38.2	38.2	45.1	35.4	35.4	42.0	32.5	32.5	38.6
					SHC	35.4	43.0	50.5	33.4	40.7	48.0	31.2	38.2	45.1	28.9	35.4	42.0	26.3	32.5	38.6
67	THC			46.9	46.9	46.9	44.0	44.0	44.0	40.9	40.9	41.6	37.5	37.5	39.9	33.8	33.8	38.0		
	SHC			28.5	36.6	44.6	27.1	35.1	43.1	25.5	33.5	41.6	23.8	31.9	39.9	22.1	30.1	38.0		
72	THC			52.0	52.0	52.0	48.9	48.9	48.9	45.6	45.6	45.6	41.9	41.9	41.9	38.0	38.0	38.0		
	SHC			20.9	29.0	37.1	19.5	27.5	35.6	17.9	26.0	34.1	16.3	24.4	32.4	14.6	22.6	30.7		
76	THC			-	56.5	56.5	-	53.2	53.2	-	49.7	49.7	-	45.8	45.8	-	-	-		
	SHC			-	22.8	31.0	-	21.4	29.5	-	19.9	28.0	-	18.2	26.3	-	-	-		
1750 Cfm	EA (wB)			58	THC	45.2	45.2	51.1	42.7	42.7	48.4	40.1	40.1	45.5	37.2	37.2	42.3	34.1	34.1	38.9
					SHC	39.2	45.2	51.1	37.0	42.7	48.4	34.7	40.1	45.5	32.1	37.2	42.3	29.3	34.1	38.9
				62	THC	45.2	45.2	53.1	42.8	42.8	50.4	40.1	40.1	47.4	37.3	37.3	44.1	34.1	34.1	40.5
					SHC	37.3	45.2	53.1	35.2	42.8	50.4	32.9	40.1	47.4	30.4	37.3	44.1	27.7	34.1	40.5
		67	THC	48.0	48.0	49.4	45.0	45.0	47.8	41.8	41.8	46.2	38.3	38.3	44.4	34.6	34.6	42.4		
			SHC	30.8	40.1	49.4	29.3	38.5	47.8	27.7	36.9	46.2	26.0	35.2	44.4	24.1	33.2	42.4		
		72	THC	53.1	53.1	53.1	50.0	50.0	50.0	46.5	46.5	46.5	42.8	42.8	42.8	38.7	38.7	38.7		
			SHC	21.9	31.2	40.6	20.4	29.7	39.1	18.8	28.2	37.5	17.2	26.5	35.8	15.5	24.8	34.1		
		76	THC	-	57.7	57.7	-	54.3	54.3	-	50.7	50.7	-	-	-	-	-	-		
			SHC	-	24.0	33.4	-	22.6	32.0	-	21.0	30.4	-	-	-	-	-	-		
		2000 Cfm	EA (wB)	58	THC	47.0	47.0	53.2	44.5	44.5	50.4	41.7	41.7	47.3	38.7	38.7	44.0	35.4	35.4	40.3
					SHC	40.8	47.0	53.2	38.6	44.5	50.4	36.1	41.7	47.3	33.4	38.7	44.0	30.5	35.4	40.3
				62	THC	47.0	47.0	55.3	44.5	44.5	52.4	41.7	41.7	49.2	38.7	38.7	45.8	35.4	35.4	42.0
					SHC	38.8	47.0	55.3	36.6	44.5	52.4	34.2	41.7	49.2	31.6	38.7	45.8	28.8	35.4	42.0
67	THC			48.9	48.9	53.8	45.8	45.8	52.2	42.6	42.6	50.4	39.1	39.1	48.4	35.5	35.5	45.4		
	SHC			32.8	43.3	53.8	31.3	41.8	52.2	29.6	40.0	50.4	27.8	38.1	48.4	25.6	35.5	45.4		
72	THC			54.0	54.0	54.0	50.7	50.7	50.7	47.2	47.2	47.2	43.4	43.4	43.4	39.2	39.2	39.2		
	SHC			22.8	33.4	43.9	21.3	31.9	42.4	19.7	30.3	40.8	18.0	28.6	39.1	16.3	26.8	37.3		
76	THC			-	58.6	58.6	-	55.2	55.2	-	-	-	-	-	-	-	-	-		
	SHC			-	25.2	35.8	-	23.7	34.3	-	-	-	-	-	-	-	-	-		
2250 Cfm	EA (wB)			58	THC	48.5	48.5	54.9	45.9	45.9	52.0	43.0	43.0	48.8	39.9	39.9	45.3	36.5	36.5	41.6
					SHC	42.2	48.5	54.9	39.8	45.9	52.0	37.2	43.0	48.8	34.4	39.9	45.3	31.4	36.5	41.6
				62	THC	48.6	48.6	57.0	45.9	45.9	54.0	43.0	43.0	50.8	39.9	39.9	47.2	36.5	36.5	43.3
					SHC	40.1	48.6	57.0	37.8	45.9	54.0	35.3	43.0	50.8	32.7	39.9	47.2	29.8	36.5	43.3
		67	THC	49.6	49.6	58.0	46.5	46.5	56.3	43.3	43.3	54.1	40.0	40.0	50.9	36.6	36.6	46.7		
			SHC	34.8	46.4	58.0	33.2	44.7	56.3	31.4	42.8	54.1	29.1	40.0	50.9	26.4	36.6	46.7		
		72	THC	54.6	54.6	54.6	51.3	51.3	51.3	47.7	47.7	47.7	43.8	43.8	43.8	39.6	39.6	40.5		
			SHC	23.6	35.4	47.2	22.1	33.9	45.7	20.5	32.3	44.1	18.8	30.6	42.3	17.1	28.8	40.5		
		76	THC	-	59.3	59.3	-	-	-	-	-	-	-	-	-	-	-	-		
			SHC	-	26.2	38.0	-	-	-	-	-	-	-	-	-	-	-	-		

**LEGEND:**

- Do not operate
- Cfm - Cubic feet per minute (supply air)
- EAT(db) - Entering air temperature (dry bulb)
- EAT(wb) - Entering air temperature (wet bulb)
- SHC - Sensible heat capacity
- TC - Total capacity



**Table 17 – COOLING CAPACITIES - SECOND STAGE FULL LOAD**

**5 TONS**

06 SIZE				AMBIENT TEMPERATURE																
				85			95			105			115			125				
				EA (dB)			EA (dB)			EA (dB)			EA (dB)			EA (dB)				
				75	80	85	75	80	85	75	80	85	75	80	85	75	80	85		
1500 Cfm	EA (wB)	58	THC	54.0	54.0	61.2	51.3	51.3	58.3	48.6	48.6	55.2	47.0	47.0	53.4	44.5	44.5	50.6		
			SHC	46.8	54.0	61.2	44.4	51.3	58.3	41.9	48.6	55.2	40.6	47.0	53.4	38.5	44.5	50.6		
		62	THC	56.5	56.5	58.4	53.3	53.3	56.5	49.9	49.9	54.6	47.8	47.8	53.8	44.8	44.8	52.3		
			SHC	42.3	50.3	58.4	40.4	48.5	56.5	38.5	46.5	54.6	37.8	45.8	53.8	36.4	44.3	52.3		
		67	THC	62.1	62.1	62.1	58.6	58.6	58.6	55.0	55.0	55.0	52.5	52.5	52.5	49.1	49.1	49.1		
			SHC	34.6	42.7	50.8	32.7	40.8	48.9	30.8	38.9	47.0	30.2	38.3	46.4	28.9	37.0	45.0		
		72	THC	68.3	68.3	68.3	64.5	64.5	64.5	60.5	60.5	60.5	57.8	57.8	57.8	54.1	54.1	54.1		
			SHC	26.7	34.8	43.0	24.8	33.0	41.1	22.9	31.1	39.2	22.4	30.5	38.6	21.1	29.2	37.3		
		76	THC	-	73.5	73.5	-	69.5	69.5	-	65.3	65.3	-	62.3	62.3	-	58.4	58.4		
			SHC	-	28.4	36.6	-	26.6	34.8	-	24.7	33	-	24.2	32.4	-	22.9	31.1		
		1750 Cfm	EA (wB)	58	THC	57.1	57.1	64.7	54.3	54.3	61.6	51.3	51.3	58.3	49.5	49.5	56.2	46.9	46.9	53.2
					SHC	49.6	57.1	64.7	47.0	54.3	61.6	44.3	51.3	58.3	42.9	49.5	56.2	40.6	46.9	53.2
				62	THC	58.4	58.4	64.5	55.0	55.0	62.5	51.6	51.6	60.2	49.7	49.7	58.3	46.9	46.9	55.4
					SHC	45.9	55.2	64.5	43.9	53.2	62.5	41.9	51.1	60.2	40.6	49.4	58.3	38.5	46.9	55.4
67	THC			63.9	63.9	63.9	60.2	60.2	60.2	56.4	56.4	56.4	53.8	53.8	53.8	50.3	50.3	50.3		
	SHC			37	46.4	55.8	35.1	44.5	53.9	33.1	42.5	51.9	32.5	41.9	51.3	31.1	40.5	49.8		
72	THC			70.2	70.2	70.2	66.2	66.2	66.2	62.0	62.0	62.0	59.1	59.1	59.1	55.3	55.3	55.3		
	SHC			27.8	37.2	46.7	25.9	35.3	44.8	23.9	33.4	42.8	23.4	32.8	42.2	22	31.4	40.8		
76	THC			-	75.4	75.4	-	71.2	71.2	-	66.9	66.9	-	63.7	63.7	-	59.6	59.6		
	SHC			-	29.8	39.4	-	27.9	37.5	-	26	35.6	-	25.4	35	-	24.1	33.6		
2000 Cfm	EA (wB)			58	THC	59.8	59.8	67.6	56.7	56.7	64.3	53.6	53.6	60.8	51.6	51.6	58.5	48.8	48.8	55.3
					SHC	51.9	59.8	67.6	49.2	56.7	64.3	46.4	53.6	60.8	44.7	51.6	58.5	42.3	48.8	55.3
				62	THC	60.0	60.0	69.9	56.8	56.8	66.9	53.7	53.7	63.3	51.7	51.7	60.9	48.8	48.8	57.6
					SHC	49.1	59.5	69.9	46.7	56.8	66.9	44.0	53.7	63.3	42.5	51.7	60.9	40.1	48.8	57.6
		67	THC	65.3	65.3	65.3	61.5	61.5	61.5	57.5	57.5	57.5	54.8	54.8	55.9	51.1	51.1	54.4		
			SHC	39.2	49.9	60.6	37.3	48.0	58.6	35.3	45.9	56.6	34.6	45.3	55.9	33.2	43.8	54.4		
		72	THC	71.6	71.6	71.6	67.5	67.5	67.5	63.2	63.2	63.2	60.1	60.1	60.1	56.2	56.2	56.2		
			SHC	28.8	39.5	50.2	26.9	37.6	48.3	24.9	35.6	46.3	24.3	35.0	45.7	22.9	33.6	44.3		
		76	THC	-	76.9	76.9	-	72.6	72.6	-	68.1	68.1	-	64.8	64.8	-	60.5	60.5		
			SHC	-	31.0	41.9	-	29.1	40	-	27.2	38	-	26.6	37.3	-	25.2	35.9		
		2250 Cfm	EA (wB)	58	THC	62.0	62.0	70.1	58.8	58.8	66.6	55.5	55.5	62.9	53.4	53.4	60.5	50.4	50.4	57.1
					SHC	53.8	62.0	70.1	51.0	58.8	66.6	48.0	55.5	62.9	46.3	53.4	60.5	43.7	50.4	57.1
				62	THC	62.0	62.0	72.9	58.9	58.9	69.3	55.5	55.5	65.5	53.4	53.4	62.9	50.4	50.4	59.4
					SHC	51.2	62.0	72.9	48.4	58.9	69.3	45.6	55.5	65.5	43.9	53.4	62.9	41.5	50.4	59.4
67	THC			66.4	66.4	66.4	62.5	62.5	63.2	58.4	58.4	61.1	55.6	55.6	60.4	51.9	51.9	58.8		
	SHC			41.4	53.3	65.2	39.4	51.3	63.2	37.4	49.3	61.1	36.7	48.5	60.4	35.2	47.0	58.8		
72	THC			72.6	72.6	72.6	68.4	68.4	68.4	64.1	64.1	64.1	60.9	60.9	60.9	56.8	56.8	56.8		
	SHC			29.6	41.6	53.6	27.7	39.7	51.7	25.8	37.7	49.7	25.1	37.1	49.0	23.8	35.7	47.6		
76	THC			-	78.0	78.0	-	73.6	73.6	-	69.0	69.0	-	65.6	65.6	-	61.2	61.2		
	SHC			-	32.2	44.3	-	30.3	42.3	-	28.3	40.3	-	27.7	39.6	-	26.3	38.1		
2500 Cfm	EA (wB)			58	THC	63.8	63.8	72.2	60.5	60.5	68.6	57.1	57.1	64.7	54.8	54.8	62.1	51.7	51.7	58.6
					SHC	55.5	63.8	72.2	52.5	60.5	68.6	49.4	57.1	64.7	47.6	54.8	62.1	44.8	51.7	58.6
				62	THC	63.9	63.9	75.1	60.6	60.6	71.3	57.1	57.1	67.4	54.9	54.9	64.6	51.8	51.8	60.9
					SHC	52.7	63.9	75.1	49.9	60.6	71.3	46.9	57.1	67.4	45.2	54.9	64.6	42.6	51.8	60.9
		67	THC	67.2	67.2	69.7	63.3	63.3	67.7	59.1	59.1	65.5	56.2	56.2	64.6	52.5	52.5	62.9		
			SHC	43.4	56.6	69.7	41.4	54.6	67.7	39.4	52.4	65.5	38.6	51.6	64.6	37.1	50.0	62.9		
		72	THC	73.5	73.5	73.5	69.2	69.2	69.2	64.7	64.7	64.7	61.5	61.5	61.5	57.4	57.4	57.4		
			SHC	30.5	43.7	56.9	28.6	41.8	55.0	26.6	39.8	53.0	26	39.1	52.3	24.6	37.7	50.8		
		76	THC	-	78.9	78.9	-	74.4	74.4	-	69.7	69.7	-	66.2	66.2	-	61.8	61.8		
			SHC	-	33.3	46.6	-	31.3	44.6	-	29.4	42.6	-	28.7	41.8	-	27.3	40.3		

**LEGEND:**

- Do not operate
- Cfm - Cubic feet per minute (supply air)
- EAT(db) - Entering air temperature (dry bulb)
- EAT(wb) - Entering air temperature (wet bulb)
- SHC - Sensible heat capacity
- TC - Total capacity

**48LC**



Table 18 – COOLING CAPACITIES

5 TONS

48LC

48LC06 (5 TONS) - UNIT WITH HUMIDI- MIZER SYSTEM IN SUBCOOLING MODE										
TEMP (F) AIR ENT CON- DENSER (Edb)		AIR ENTERING EVAPORATOR - CFM/BF								
		1,200			1,600			2,000		
		Air Entering Evaporator - Ewb (F)								
		72	67	62	72	67	62	72	67	62
75	TC	61.3	54.7	48.0	66.8	59.4	52.0	71.5	63.5	55.5
	SHC	27.6	29.2	34.4	32.7	35.7	43.5	37.9	41.6	48.0
	kW	2.98	2.91	2.84	3.02	2.96	2.89	3.06	2.99	2.92
85	TC	56.0	49.4	42.8	60.4	53.1	45.8	64.2	56.3	48.4
	SHC	22.4	24.2	30.8	27.2	30.1	39.6	31.5	35.4	43.5
	kW	3.36	3.28	3.21	3.40	3.33	3.26	3.45	3.37	3.30
95	TC	50.8	44.2	37.6	54.0	46.8	39.6	56.9	49.1	41.3
	SHC	17.3	19.3	27.2	21.6	24.6	35.6	25.6	29.3	38.7
	kW	3.74	3.65	3.57	3.80	3.71	3.63	3.84	3.76	3.67
105	TC	45.5	39.0	32.4	47.7	40.5	33.4	49.6	41.9	34.2
	SHC	12.3	14.3	23.6	16.7	18.9	31.3	20.3	23.1	33.6
	kW	4.11	4.02	3.93	4.18	4.09	3.99	4.23	4.14	4.05
115	TC	40.2	33.7	27.2	41.3	34.2	27.2	42.3	34.7	27.1
	SHC	7.2	9.4	20.1	11.6	13.4	26.8	14.8	16.9	26.7
	kW	4.49	4.39	4.29	4.57	4.50	4.37	4.62	4.50	4.42
125	TC	34.9	28.5	22.0	35.0	28.0	20.9	35.0	27.5	19.9
	SHC	3.1	4.5	16.5	7.4	7.8	20.5	10.2	10.8	19.8
	kW	4.87	4.77	4.66	4.95	4.84	4.73	5.01	4.90	4.79

48LC06 (5 TONS) - UNIT WITH HUMIDI- MIZER SYSTEM IN HOT GAS REHEAT MODE										
TEMP (F) AIR ENT CONDENSER (Edb)		AIR ENTERING EVAPORATOR - Ewb (F)								
		75 Dry Bulb 62.5 Wet Bulb (50% Relative)			75 Dry Bulb 64 Wet Bulb (56% Relative)			75 Dry Bulb 65.3 Wet Bulb (60% Relative)		
		Air Entering Evaporator - Cfm								
		1,500	2,000	2,500	1,500	2,000	2,500	1,500	2,000	2,500
80	TC	15.77	17.98	19.86	15.63	17.83	19.71	15.51	17.70	19.58
	SHC	8.08	11.03	13.66	5.59	8.16	10.45	3.43	5.67	7.66
	kW	1.89	1.84	1.81	1.89	1.88	1.84	1.95	1.90	1.87
75	TC	16.71	18.99	20.94	16.62	18.90	20.85	16.55	18.82	20.77
	SHC	8.55	11.47	14.08	6.23	8.81	11.10	4.23	6.50	8.52
	kW	1.77	1.73	1.70	1.77	1.76	1.73	1.83	1.79	1.76
70	TC	17.64	20.00	22.02	17.61	19.98	21.99	17.58	19.95	21.97
	SHC	9.01	11.91	14.45	6.88	9.45	11.75	5.02	7.32	9.36
	kW	1.66	1.62	1.59	1.66	1.65	1.62	1.71	1.67	1.65
60	TC	19.51	22.02	24.17	19.59	22.12	24.28	19.66	22.20	24.37
	SHC	9.94	12.79	15.33	8.16	10.74	13.04	6.62	8.97	11.06
	kW	1.43	1.39	1.37	1.43	1.42	1.40	1.48	1.45	1.42

**LEGEND**

- Edb - Entering Dry- Bulb
- Ewb - Entering Wet- Bulb
- kW - Compressor Motor Power Input
- ldb - Leaving Dry- Bulb
- lwb - Leaving Wet- Bulb
- SHC - Sensible Heat Capacity (1000 Btuh) Gross
- TC - Total Capacity (1000 Btuh) Gross

**NOTES:**

- 1 Direct interpolation is permissible. Do not extrapolate.
- 2 The following formulas may be used:

$$t_{ldb} = t_{edb} - \frac{\text{sensible capacity (Btuh)}}{1.10 \times \text{cfm}}$$

$t_{lwb}$  = Wet- bulb temperature corresponding to enthalpy of air leaving evaporator coil ( $h_{lwb}$ )

$$h_{lwb} = h_{ewb} - \frac{\text{total capacity (Btuh)}}{4.5 \times \text{cfm}}$$

Where:  $h_{ewb}$  = Enthalpy of air entering evaporator coil

# ECONOMIZER, BAROMETRIC RELIEF AND PE PERFORMANCE

## Vertical Application

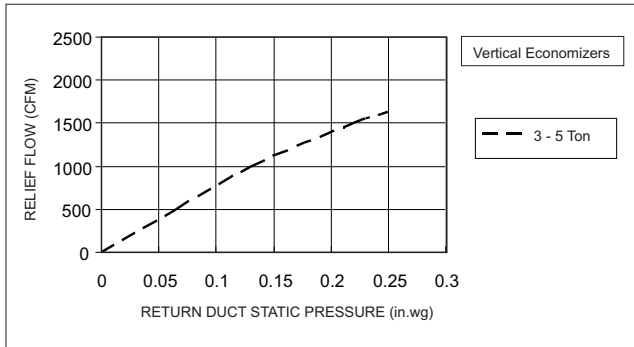

C11539

**Fig. 5 - Barometric Relief Flow- Vertical 3 - 5 Ton**

## Horizontal Application

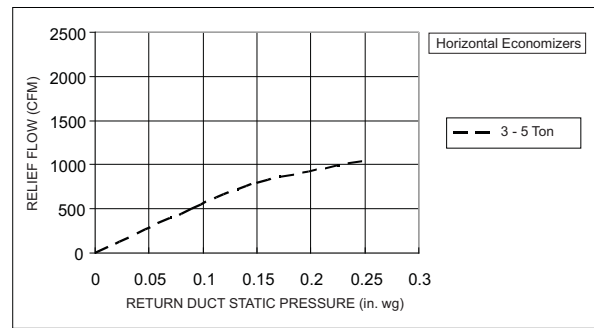

C11542

**Fig. 8 - Barometric Relief Flow - Horizontal 3 - 5 Ton**

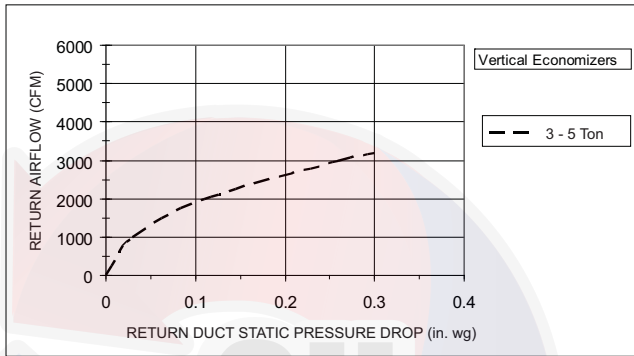

C11541

**Fig. 6 - Return Air Pressure Drop- Vertical 3 - 5 Ton**

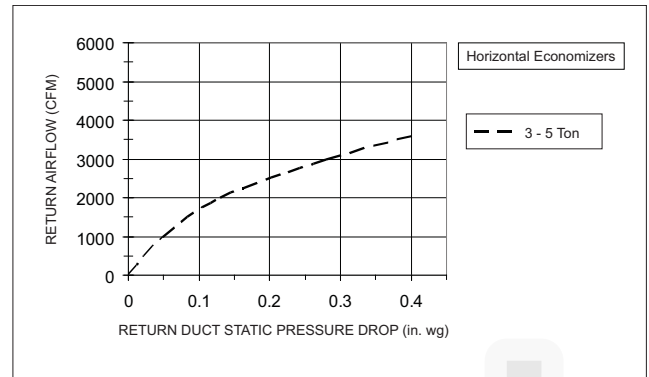

C11543

**Fig. 9 - Return Air Pressure Drop - Horizontal 3 - 5 Ton**

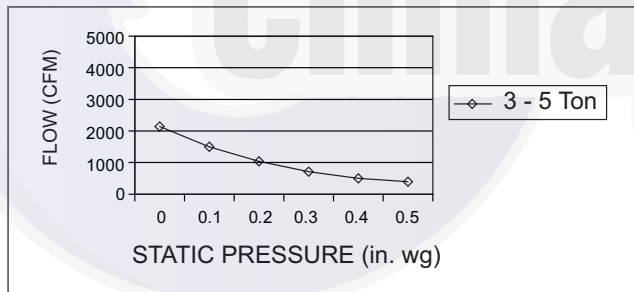

C11540

**Fig. 7 - Vertical Power Exhaust Performance**

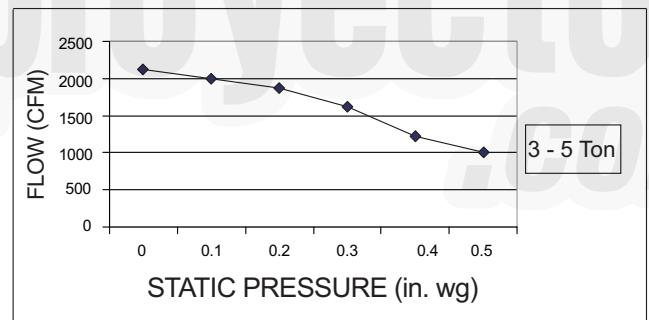

C12179

**Fig. 10 - Horizontal Power Exhaust Performance**

**Table 19 – STATIC PRESSURE ADDERS (IN. WG) (FACTORY OPTIONS AND/OR ACCESSORIES)**

CFM	1000	1250	1500	1750	2000	2250	2500
3 Tons Humidi- MiZer Coil	0.04	0.052	0.07	-	-	-	-
4 Tons Humidi- MiZer Coil	-	0.106	0.138	0.172	0.21	-	-
5 Tons Humidi- MiZer Coil	-	-	0.138	0.172	0.21	0.252	0.30

48LC

## GENERAL FAN PERFORMANCE NOTES:

1. Interpolation is permissible. Do not extrapolate.
2. External static pressure is the static pressure difference between the return duct and the supply duct plus the static pressure caused by any FIOPs or accessories.
3. Tabular data accounts for pressure loss due to clean filters, unit casing, and wet coils. Factory options and accessories may add static pressure losses. Selection software is available, through your salesperson, to help you select the best motor/drive combination for your application.
4. The Fan Performance tables offer motor/drive recommendations. In cases when two motor/drive combinations would work, Carrier recommended the lower horsepower option.
5. For information on the electrical properties of Carrier motors, please see the Electrical information section of this book.
6. For more information on the performance limits of Carrier motors, see the application data section of this book.
7. The EPACT (Energy Policy Act) regulates energy requirements for specific types of indoor fan motors. Motors regulated by EPACT include any general purpose, T-frame (three-digit, 143 and larger), single-speed, foot mounted, polyphase, squirrel cage induction motors of NEMA (National Electrical Manufacturers Association) design A and B, manufactured for use in the United States. Ranging from 1 to 200 Hp, these continuous-duty motors operate on 230 and 460 volt, 60 Hz power. If a motor does not fit into these specifications, the motor does not have to be replaced by an EPACT compliant energy-efficient motor. Variable-speed motors are exempt from EPACT compliance requirements.



# FAN PERFORMANCE

## DIRECT DRIVE - ECM (Multi-Speed) INDOOR FAN MOTOR

Table 20 – 48LC\*004 Vertical Unit- Direct Drive

Speed (Torque) Tap	CFM	ESP	BHP
1	750	0.27	0.15
	900	0.07	0.11
	1050	-	-
	1125	-	-
	1200	-	-
	1275	-	-
	1350	-	-
	1425	-	-
1500	-	-	
2	750	0.54	0.21
	900	0.29	0.18
	1050	0.06	0.16
	1125	-	-
	1200	-	-
	1275	-	-
	1350	-	-
	1425	-	-
1500	-	-	
3	750	1.15	0.42
	900	0.96	0.43
	1050	0.70	0.40
	1125	0.55	0.40
	1200	0.41	0.39
	1275	0.27	0.39
	1350	-	-
	1425	-	-
1500	-	-	
4	750	1.19	0.43
	900	1.06	0.46
	1050	0.91	0.50
	1125	0.83	0.53
	1200	0.75	0.55
	1275	0.66	0.56
	1350	0.56	0.57
	1425	-	-
1500	-	-	
5	750	1.21	0.42
	900	1.06	0.46
	1050	0.91	0.50
	1125	0.83	0.52
	1200	0.79	0.55
	1275	0.71	0.57
	1350	0.63	0.59
	1425	0.56	0.62
1500	0.47	0.64	

Table 21 – 48LC\*004 Horizontal Unit- Direct Drive

Speed (Torque) Tap	CFM	ESP	BHP
1	750	0.39	0.19
	900	0.18	0.14
	1050	-	-
	1125	-	-
	1200	-	-
	1275	-	-
	1350	-	-
	1425	-	-
1500	-	-	
2	750	0.69	0.26
	900	0.45	0.23
	1050	0.22	0.20
	1125	0.12	0.19
	1200	0.05	0.17
	1275	-	-
	1350	-	-
	1425	-	-
1500	-	-	
3	750	1.28	0.44
	900	1.11	0.46
	1050	0.88	0.45
	1125	0.75	0.44
	1200	0.63	0.44
	1275	0.50	0.44
	1350	0.38	0.41
	1425	0.25	0.39
1500	0.13	0.38	
4	750	1.30	0.45
	900	1.17	0.48
	1050	1.04	0.52
	1125	0.97	0.54
	1200	0.91	0.56
	1275	0.84	0.58
	1350	0.76	0.60
	1425	0.68	0.61
1500	0.60	0.62	
5	750	1.31	0.45
	900	1.18	0.48
	1050	1.04	0.52
	1125	0.97	0.54
	1200	0.92	0.56
	1275	0.86	0.59
	1350	0.80	0.61
	1425	0.74	0.64
1500	0.68	0.66	

NOTE: To convert BHP to watts, use 84% motor efficiency

48LC

## FAN PERFORMANCE (cont.)

### DIRECT DRIVE - ECM (Multi-Speed) INDOOR FAN MOTOR (cont.)

**Table 22 – 48LC\*005 Vertical Unit-Direct Drive**

Speed (Torque) Tap	CFM	ESP	BHP
1	1000	0.08	0.11
	1200	-	-
	1400	-	-
	1500	-	-
	1600	-	-
	1700	-	-
	1800	-	-
	1900	-	-
	2000	-	-
2	1000	0.79	0.37
	1200	0.49	0.34
	1400	0.20	0.31
	1500	0.05	0.29
	1600	-	-
	1700	-	-
	1800	-	-
	1900	-	-
	2000	-	-
3	1000	1.11	0.50
	1200	0.90	0.57
	1400	0.59	0.62
	1500	0.40	0.59
	1600	0.20	0.52
	1700	-	-
	1800	-	-
	1900	-	-
	2000	-	-
4	1000	1.12	0.50
	1200	0.95	0.57
	1400	0.79	0.63
	1500	0.70	0.67
	1600	0.61	0.70
	1700	0.52	0.73
	1800	0.41	0.75
	1900	0.30	0.77
	2000	-	-
5	1000	1.13	0.51
	1200	0.97	0.58
	1400	0.79	0.65
	1500	0.70	0.68
	1600	0.64	0.72
	1700	0.55	0.75
	1800	0.46	0.79
	1900	0.35	0.82
	2000	0.25	0.89

**Table 23 – 48LC\*005 Horizontal Unit-Direct Drive**

Speed (Torque) Tap	CFM	ESP	BHP
1	1000	0.12	0.14
	1200	0.00	0.21
	1400	-	-
	1500	-	-
	1600	-	-
	1700	-	-
	1800	-	-
	1900	-	-
	2000	-	-
2	1000	0.89	0.43
	1200	0.60	0.40
	1400	0.30	0.36
	1500	0.16	0.34
	1600	0.02	0.32
	1700	-	-
	1800	-	-
	1900	-	-
	2000	-	-
3	1000	1.14	0.52
	1200	0.96	0.59
	1400	0.70	0.65
	1500	0.54	0.64
	1600	0.37	0.61
	1700	0.18	0.61
	1800	0.00	0.55
	1900	-	-
	2000	-	-
4	1000	1.15	0.52
	1200	1.01	0.59
	1400	0.86	0.65
	1500	0.79	0.69
	1600	0.72	0.72
	1700	0.64	0.75
	1800	0.56	0.79
	1900	0.47	0.82
	2000	0.37	0.84
5	1000	1.15	0.53
	1200	1.02	0.60
	1400	0.86	0.67
	1500	0.79	0.70
	1600	0.74	0.74
	1700	0.67	0.78
	1800	0.59	0.82
	1900	0.51	0.86
	2000	0.42	0.92

**NOTE:** To convert BHP to watts, use 84% motor efficiency

48LC



## FAN PERFORMANCE (cont.)

### DIRECT DRIVE - ECM (Multi-Speed) INDOOR FAN MOTOR (cont.)

**Table 24 – 48LC\*006 Vertical Unit-Direct Drive**

Speed (Torque) tap	CFM	ESP	BHP
1	1250	0.03	0.16
	1500	-	-
	1750	-	-
	1875	-	-
	2000	-	-
	2125	-	-
	2250	-	-
	2375	-	-
2500	-	-	
2	1250	0.89	0.57
	1500	0.41	0.53
	1750	0.03	0.49
	1875	-	-
	2000	-	-
	2125	-	-
	2250	-	-
	2375	-	-
2500	-	-	
3	1250	1.15	0.72
	1500	0.74	0.72
	1750	0.30	0.68
	1875	0.10	0.65
	2000	0.05	0.61
	2125	-	-
	2250	-	-
	2375	-	-
2500	-	-	
4	1250	-	-
	1500	0.94	0.83
	1750	0.59	0.87
	1875	0.40	0.82
	2000	0.20	0.83
	2125	0.01	0.80
	2250	-	-
	2375	-	-
2500	-	-	
5	1250	1.28	0.78
	1500	1.00	0.87
	1750	0.59	0.95
	1875	0.40	0.98
	2000	0.41	1.01
	2125	0.25	0.88
	2250	0.06	1.01
	2375	-	-
2500	-	-	

**Table 25 – 48LC\*006 Horizontal Unit-Direct Drive**

Speed (Torque) tap	CFM	ESP	BHP
1	1250	0.04	0.18
	1500	-	-
	1750	-	-
	1875	-	-
	2000	-	-
	2125	-	-
	2250	-	-
	2375	-	-
2500	-	-	
2	1250	0.99	0.63
	1500	0.55	0.58
	1750	0.14	0.53
	1875	0.01	0.49
	2000	-	-
	2125	-	-
	2250	-	-
	2375	-	-
2500	-	-	
3	1250	1.24	0.76
	1500	0.88	0.77
	1750	0.44	0.73
	1875	0.24	0.70
	2000	0.07	0.66
	2125	-	-
	2250	-	-
	2375	-	-
2500	-	-	
4	1250	1.33	0.81
	1500	1.07	0.89
	1750	0.74	0.93
	1875	0.56	0.88
	2000	0.36	0.91
	2125	0.15	0.88
	2250	-	-
	2375	-	-
2500	-	-	
5	1250	1.35	0.82
	1500	1.12	0.92
	1750	0.74	1.00
	1875	0.56	1.04
	2000	0.56	1.08
	2125	0.39	0.95
	2250	0.19	1.09
	2375	-	-
2500	-	-	

**NOTE:** To convert BHP to watts, use 84% motor efficiency

48LC

# FAN PERFORMANCE (BELT DRIVE WITH VFD CONTROLLER & DISPLAY)

Table 26 – 48LC\*004

3 PHASE

3 TON VERTICAL SUPPLY

CFM	Available External Static Pressure (in. wg)									
	0.2		0.4		0.6		0.8		1.0	
	RPM	BHP	RPM	BHP	RPM	BHP	RPM	BHP	RPM	BHP
900	<b>592</b>	<b>0.14</b>	<b>721</b>	<b>0.25</b>	826	0.38	916	0.53	997	0.69
975	<b>616</b>	<b>0.17</b>	<b>744</b>	<b>0.28</b>	847	0.41	936	0.56	1016	0.72
1050	<b>641</b>	<b>0.19</b>	<b>766</b>	<b>0.30</b>	868	0.44	957	0.59	1036	0.76
1125	<b>667</b>	<b>0.22</b>	790	0.33	890	0.47	978	0.63	1056	0.80
1200	<b>693</b>	<b>0.25</b>	813	0.37	913	0.51	999	0.67	1077	0.84
1275	<b>720</b>	<b>0.29</b>	837	0.41	935	0.55	1021	0.71	1098	0.88
1350	<b>747</b>	<b>0.33</b>	862	0.45	958	0.60	1043	0.76	1119	0.94
1425	775	0.37	887	0.50	982	0.65	1066	0.81	1141	0.99
1500	802	0.42	912	0.55	1006	0.70	1088	0.87	1163	1.05

CFM	Available External Static Pressure (in. wg)									
	1.2		1.4		1.6		1.8		2.0	
	RPM	BHP	RPM	BHP	RPM	BHP	RPM	BHP	RPM	BHP
900	1070	0.88	1137	1.07	1201	1.29	1260	1.51	1317	1.75
975	1089	0.91	1156	1.11	1219	1.32	1279	1.54	1335	1.78
1050	1108	0.94	1175	1.14	1238	1.36	1297	1.58	1353	1.82
1125	1128	0.98	1195	1.18	1257	1.40	1316	1.62	1372	1.86
1200	1148	1.03	1214	1.23	1276	1.44	1335	1.67	1391	1.91
1275	1169	1.07	1235	1.28	1296	1.50	1354	1.72	1410	1.97
1350	1190	1.13	1255	1.33	1316	1.55	1374	1.78	1429	2.03
1425	1211	1.19	1276	1.39	1337	1.61	1394	1.85	1449	2.09
1500	1232	1.25	1297	1.46	1357	1.68	1415	1.91	<b>1469</b>	<b>2.16</b>

NOTE: For more information, see General Fan Performance Notes.

**Boldface** indicates field- supplied drive is required.

Medium static 770- 1175 RPM, 1.2 BHP max

High static 1035- 1466 RPM, 2.4 BHP max

Table 27 – 48LC\*004

3 PHASE

3 TON HORIZONTAL SUPPLY

CFM	Available External Static Pressure (in. wg)									
	0.2		0.4		0.6		0.8		1.0	
	RPM	BHP	RPM	BHP	RPM	BHP	RPM	BHP	RPM	BHP
900	<b>582</b>	<b>0.14</b>	<b>715</b>	<b>0.24</b>	825	0.35	921	0.48	1007	0.63
975	<b>606</b>	<b>0.16</b>	<b>735</b>	<b>0.26</b>	843	0.38	938	0.51	1023	0.66
1050	<b>630</b>	<b>0.18</b>	<b>756</b>	<b>0.29</b>	862	0.41	955	0.55	1040	0.70
1125	<b>655</b>	<b>0.21</b>	778	0.32	882	0.45	974	0.58	1057	0.74
1200	<b>681</b>	<b>0.24</b>	800	0.35	902	0.48	992	0.63	1074	0.78
1275	<b>708</b>	<b>0.27</b>	823	0.39	923	0.53	1012	0.67	1093	0.83
1350	<b>735</b>	<b>0.31</b>	847	0.43	945	0.57	1032	0.72	1112	0.88
1425	<b>762</b>	<b>0.35</b>	871	0.48	967	0.62	1053	0.77	1131	0.94
1500	790	0.40	896	0.53	990	0.67	1074	0.83	1151	1.00

CFM	Available External Static Pressure (in. wg)									
	1.2		1.4		1.6		1.8		2.0	
	RPM	BHP	RPM	BHP	RPM	BHP	RPM	BHP	RPM	BHP
900	1086	0.79	1159	0.96	1228	1.14	1293	1.33	1354	1.53
975	1101	0.82	1174	0.99	1242	1.18	1306	1.37	1367	1.57
1050	1117	0.86	1189	1.03	1256	1.22	1320	1.41	1381	1.62
1125	1133	0.90	1204	1.08	1271	1.26	1335	1.46	1395	1.67
1200	1150	0.95	1221	1.13	1287	1.31	1350	1.51	1410	1.72
1275	1168	1.00	1237	1.18	1303	1.37	1365	1.57	1425	1.78
1350	1186	1.05	1255	1.24	1320	1.43	1382	1.63	1441	1.84
1425	1204	1.11	1272	1.30	1337	1.49	1398	1.70	1457	1.91
1500	1223	1.18	1291	1.36	1355	1.56	1415	1.77	<b>1473</b>	<b>1.99</b>

NOTE: For more information, see General Fan Performance Notes.

**Boldface** indicates field- supplied drive is required.

Medium static 770- 1175 RPM, 1.2 BHP max

High static 1035- 1466 RPM, 2.4 BHP max

# FAN PERFORMANCE (BELT DRIVE WITH VFD CONTROLLER & DISPLAY)

cont.

Table 28 – 48LC\*005

3 PHASE

4 TON VERTICAL SUPPLY

CFM	Available External Static Pressure (in. wg)									
	0.2		0.4		0.6		0.8		1.0	
	RPM	BHP	RPM	BHP	RPM	BHP	RPM	BHP	RPM	BHP
1200	<b>693</b>	<b>0.25</b>	<b>813</b>	<b>0.37</b>	<b>913</b>	<b>0.51</b>	999	0.67	1077	0.84
1300	<b>729</b>	<b>0.30</b>	<b>846</b>	<b>0.42</b>	943	0.57	1028	0.73	1105	0.90
1400	<b>765</b>	<b>0.35</b>	<b>879</b>	<b>0.48</b>	974	0.63	1058	0.79	1134	0.97
1500	<b>802</b>	<b>0.42</b>	<b>912</b>	<b>0.55</b>	1006	0.70	1088	0.87	1163	1.05
1600	<b>840</b>	<b>0.49</b>	947	0.63	1038	0.78	1119	0.95	1193	1.14
1700	<b>878</b>	<b>0.57</b>	982	0.71	1071	0.87	1151	1.05	1224	1.24
1800	<b>917</b>	<b>0.65</b>	1017	0.81	1105	0.97	1183	1.15	1255	1.35
1900	956	0.75	1053	0.91	1139	1.08	1216	1.27	1287	1.47
2000	995	0.86	1090	1.02	1173	1.20	1249	1.39	1319	1.59

CFM	Available External Static Pressure (in. wg)									
	1.2		1.4		1.6		1.8		2.0	
	RPM	BHP	RPM	BHP	RPM	BHP	RPM	BHP	RPM	BHP
1200	1148	1.03	1214	1.23	1276	1.44	1335	1.67	1391	1.91
1300	1176	1.09	1241	1.30	1303	1.51	1361	1.74	1416	1.98
1400	1204	1.17	1269	1.37	1330	1.59	1388	1.82	1442	2.07
1500	1232	1.25	1297	1.46	1357	1.68	1415	1.91	1469	2.16
1600	1262	1.34	1325	1.55	1385	1.78	1442	2.01	1496	2.26
1700	1291	1.44	1354	1.66	1414	1.89	1470	2.12	1524	2.37
1800	1322	1.55	1384	1.77	1443	2.00	1499	2.25	1552	2.50
1900	1352	1.68	1414	1.90	1472	2.13	1528	2.38	1580	2.63
2000	1384	1.81	1445	2.04	1502	2.27	1557	2.52	1609	2.78

NOTE: For more information, see General Fan Performance Notes.

**Boldface** indicates field- supplied drive is required.

Medium static 920- 1303 RPM, 1.7 BHP max

High static 1208- 1639 RPM, 2.9 BHP max

Table 29 – 48LC\*005

3 PHASE

4 TON HORIZONTAL SUPPLY

CFM	Available External Static Pressure (in. wg)									
	0.2		0.4		0.6		0.8		1.0	
	RPM	BHP	RPM	BHP	RPM	BHP	RPM	BHP	RPM	BHP
1200	<b>681</b>	<b>0.24</b>	<b>800</b>	<b>0.35</b>	<b>902</b>	<b>0.48</b>	992	0.63	1074	0.78
1300	<b>717</b>	<b>0.29</b>	<b>831</b>	<b>0.41</b>	930	0.54	1019	0.69	1099	0.85
1400	<b>753</b>	<b>0.34</b>	<b>863</b>	<b>0.46</b>	959	0.60	1046	0.75	1125	0.92
1500	<b>790</b>	<b>0.40</b>	<b>896</b>	<b>0.53</b>	990	0.67	1074	0.83	1151	1.00
1600	<b>828</b>	<b>0.46</b>	930	0.60	1021	0.75	1103	0.91	1179	1.09
1700	<b>866</b>	<b>0.54</b>	964	0.68	1053	0.84	1133	1.01	1207	1.18
1800	<b>905</b>	<b>0.62</b>	1000	0.77	1085	0.94	1164	1.11	1236	1.29
1900	944	0.71	1036	0.87	1119	1.04	1195	1.22	1266	1.41
2000	984	0.82	1072	0.98	1153	1.15	1227	1.34	1297	1.53

CFM	Available External Static Pressure (in. wg)									
	1.2		1.4		1.6		1.8		2.0	
	RPM	BHP	RPM	BHP	RPM	BHP	RPM	BHP	RPM	BHP
1200	1150	0.95	1221	1.13	1287	1.31	1350	1.51	1410	1.72
1300	1173	1.02	1243	1.20	1309	1.39	1371	1.59	1430	1.80
1400	1198	1.09	1266	1.28	1331	1.47	1393	1.68	1451	1.89
1500	1223	1.18	1291	1.36	1355	1.56	1415	1.77	1473	1.99
1600	1249	1.27	1316	1.46	1379	1.66	1439	1.87	1496	2.09
1700	1277	1.37	1342	1.57	1404	1.77	1463	1.99	1520	2.21
1800	1305	1.48	1369	1.68	1430	1.89	1489	2.11	1545	2.34
1900	1333	1.60	1397	1.81	1457	2.02	1514	2.25	1570	2.48
2000	1363	1.73	1425	1.94	1484	2.16	1541	2.39	1596	2.63

NOTE: For more information, see General Fan Performance Notes.

**Boldface** indicates field- supplied drive is required.

Medium static 920- 1303 RPM, 1.7 BHP max

High static 1208- 1639 RPM, 2.9 BHP max

48LC

# FAN PERFORMANCE (BELT DRIVE WITH VFD CONTROLLER & DISPLAY)

cont.

Table 30 – 48LC\*006

3 PHASE

5 TON VERTICAL SUPPLY

CFM	Available External Static Pressure (in. wg)									
	0.2		0.4		0.6		0.8		1.0	
	RPM	BHP	RPM	BHP	RPM	BHP	RPM	BHP	RPM	BHP
1500	<b>847</b>	<b>0.41</b>	966	0.55	1067	0.68	1158	0.81	1240	0.93
1625	<b>896</b>	<b>0.50</b>	1010	0.65	1109	0.79	1198	0.93	1278	1.07
1750	<b>947</b>	<b>0.59</b>	1056	0.76	1152	0.92	1238	1.07	1318	1.22
1875	<b>998</b>	<b>0.70</b>	1103	0.88	1196	1.05	1280	1.22	1358	1.38
2000	1049	0.82	1151	1.02	1241	1.20	1323	1.38	1399	1.56
2125	1102	0.96	1199	1.17	1287	1.37	1367	1.56	1441	1.75
2250	1154	1.11	1248	1.33	1333	1.55	1411	1.75	1484	1.96
2375	1208	1.28	1298	1.52	1381	1.74	1457	1.96	1528	2.18
2500	1261	1.47	1349	1.72	1429	1.96	1503	2.19	1572	2.42

CFM	Available External Static Pressure (in. wg)									
	1.2		1.4		1.6		1.8		2.0	
	RPM	BHP	RPM	BHP	RPM	BHP	RPM	BHP	RPM	BHP
1500	1316	1.05	1387	1.17	1454	1.28	1517	1.39	1578	1.50
1625	1353	1.20	1423	1.33	1489	1.46	1552	1.58	1611	1.70
1750	1391	1.36	1460	1.51	1525	1.65	1587	1.78	1646	1.91
1875	1430	1.54	1498	1.70	1562	1.85	1623	2.00	1681	2.14
2000	1470	1.73	1537	1.90	1600	2.06	1660	2.23	<b>1718</b>	<b>2.38</b>
2125	1511	1.93	1576	2.12	1639	2.29	<b>1698</b>	<b>2.47</b>	<b>1755</b>	<b>2.64</b>
2250	1552	2.15	1617	2.35	1678	2.54	<b>1737</b>	<b>2.73</b>	1793	2.92
2375	1595	2.39	1658	2.60	<b>1718</b>	<b>2.80</b>	1776	3.01	-	-
2500	1638	2.64	<b>1700</b>	<b>2.87</b>	1760	3.08	-	-	-	-

NOTE: For more information, see General Fan Performance Notes.

**Boldface** indicates field- supplied drive is required.

Medium static 1035- 1466 RPM, 2.4 BHP max

High static 1303 - 1687 RPM, 2.9 BHP max

Table 31 – 48LC\*006

3 PHASE

5 TON HORIZONTAL SUPPLY

CFM	Available External Static Pressure (in. wg)									
	0.2		0.4		0.6		0.8		1.0	
	RPM	BHP	RPM	BHP	RPM	BHP	RPM	BHP	RPM	BHP
1500	<b>798</b>	<b>0.41</b>	906	0.55	1002	0.71	1088	0.87	1167	1.05
1625	<b>845</b>	<b>0.50</b>	949	0.65	1041	0.81	1125	0.98	1202	1.17
1750	<b>893</b>	<b>0.60</b>	993	0.76	1081	0.93	1163	1.11	1238	1.30
1875	<b>942</b>	<b>0.71</b>	1037	0.88	1123	1.06	1202	1.25	1275	1.44
2000	<b>992</b>	<b>0.84</b>	1083	1.02	1166	1.21	1242	1.40	1313	1.61
2125	1043	0.98	1129	1.17	1209	1.37	1283	1.57	1353	1.79
2250	1093	1.14	1177	1.34	1254	1.55	1325	1.76	1393	1.98
2375	1145	1.32	1225	1.53	1299	1.74	1369	1.97	1434	2.20
2500	1196	1.51	1273	1.73	1345	1.96	1413	2.19	1477	2.43

CFM	Available External Static Pressure (in. wg)									
	1.2		1.4		1.6		1.8		2.0	
	RPM	BHP	RPM	BHP	RPM	BHP	RPM	BHP	RPM	BHP
1500	1241	1.23	1310	1.42	1375	1.63	1438	1.84	1497	2.06
1625	1274	1.36	1342	1.56	1406	1.77	1467	1.98	1526	2.21
1750	1308	1.50	1375	1.70	1438	1.92	1498	2.14	1555	2.37
1875	1344	1.65	1409	1.86	1471	2.09	1530	2.32	1586	2.55
2000	1380	1.82	1444	2.04	1505	2.27	1563	2.51	1619	2.75
2125	1418	2.01	1481	2.24	1540	2.47	1597	2.72	<b>1652</b>	<b>2.97</b>
2250	1457	2.21	1518	2.45	1576	2.69	<b>1632</b>	<b>2.94</b>	<b>1686</b>	<b>3.20</b>
2375	1497	2.43	1556	2.68	<b>1614</b>	<b>2.93</b>	<b>1669</b>	<b>3.19</b>	-	-
2500	1538	2.68	<b>1596</b>	<b>2.93</b>	<b>1652</b>	<b>3.19</b>	-	-	-	-

NOTE: For more information, see General Fan Performance Notes.

**Boldface** indicates field- supplied drive is required.

Medium static 1035- 1466 RPM, 2.4 BHP max

High static 1303- 1687 RPM, 2.9 BHP max

## FAN PERFORMANCE (cont.)

**Table 32 – PULLEY ADJUSTMENT**

UNIT	MOTOR/ DRIVE COMBO	MOTOR PULLEY TURNS OPEN (RPM)										
		0.0	0.5	1.0	1.5	2.0	2.5	3.0	3.5	4.0	4.5	5.0
04	Standard Static	-	-	-	-	-	-	-	-	-	-	-
	Medium Static	1175	1135	1094	1054	1013	973	932	892	851	811	770
	High Static	1466	1423	1380	1337	1294	1251	1207	1164	1121	1078	1035
05	Standard Static	-	-	-	-	-	-	-	-	-	-	-
	Medium Static	1303	1265	1226	1188	1150	1112	1073	1035	997	958	920
	High Static	1639	1596	1553	1510	1467	1424	1380	1337	1294	1251	1208
06	Standard Static	-	-	-	-	-	-	-	-	-	-	-
	Medium Static	1466	1423	1380	1337	1294	1251	1207	1164	1121	1078	1035
	High Static	1687	1649	1610	1572	1533	1495	1457	1418	1380	1341	1303

- Factory settings
- Standard static uses direct drive motor

48LC



# ELECTRICAL INFORMATION

Table 33 – 48LC\*004-006

3-5 TONS

	V-Ph-Hz	VOLTAGE RANGE		COMP 1		OFM (ea)		IFM		
		MIN	MAX	RLA	LRA	WATTS	FLA	TYPE	EFF at Full Load	FLA
48LC*004	208-3-60	187	253	11.6	73	190	3.5	DD-STD	84.0%	5.8
						190	3.5	STD	81.5%	5.8
						190	3.5	MED	81.5%	5.8
						190	3.5	HIGH	80.0%	7.1
	230-3-60	187	253	11.6	73	190	3.5	DD-STD	84.0%	5.8
						190	3.5	STD	81.5%	5.6
						190	3.5	MED	81.5%	5.6
						190	3.5	HIGH	80.0%	6.8
	460-3-60	414	506	5.7	38	190	1.4	DD-STD	84.0%	3.2
						190	1.4	STD	81.5%	2.9
						190	1.4	MED	81.5%	2.9
						190	1.4	HIGH	80.0%	3.8
	575-3-60	518	633	4.0	26	190	1.4	DD-STD	84.0%	3.2
						190	1.4	STD	81.5%	2.8
						190	1.4	MED	81.5%	2.8
						190	1.4	HIGH	80.0%	3.5
48LC*005	208-3-60	187	253	14.0	83	240	3.5	DD-STD	78.0%	7.4
						240	3.5	STD	81.5%	5.8
						240	3.5	MED	81.5%	5.8
						240	3.5	HIGH	84.5%	8.6
	230-3-60	187	253	14.0	83	240	3.5	DD-STD	78.0%	7.4
						240	3.5	STD	81.5%	5.6
						240	3.5	MED	81.5%	5.6
						240	3.5	HIGH	84.5%	7.8
	460-3-60	414	506	6.4	41	220	1.4	DD-STD	78.0%	4
						220	1.4	STD	81.5%	2.9
						220	1.4	MED	81.5%	2.9
						220	1.4	HIGH	84.5%	3.8
	575-3-60	518	633	4.6	33	220	1.4	DD-STD	78.0%	4
						220	1.4	STD	81.5%	2.8
						220	1.4	MED	81.5%	2.8
						220	1.4	HIGH	84.5%	4.5
48LC*006	208-3-60	187	253	16.2	110	240	3.5	DD-STD	78.0%	7.4
						240	3.5	STD	80.0%	7.1
						240	3.5	MED	80.0%	7.1
						240	3.5	HIGH	84.5%	8.6
	230-3-60	187	253	16.2	110	240	3.5	DD-STD	78.0%	7.4
						240	3.5	STD	80.0%	6.8
						240	3.5	MED	80.0%	6.8
						240	3.5	HIGH	84.5%	7.8
	460-3-60	414	506	7.6	52	220	1.4	DD-STD	78.0%	4
						220	1.4	STD	80.0%	3.8
						220	1.4	MED	80.0%	3.8
						220	1.4	HIGH	84.5%	3.8
	575-3-60	518	633	5.3	39	220	1.4	DD-STD	78.0%	4
						220	1.4	STD	80.0%	3.5
						220	1.4	MED	80.0%	3.5
						220	1.4	HIGH	84.5%	4.5

48LC



# MCA/MOCP

**Table 34 – MCA/MOCP DETERMINATION NO C.O. OR UNPWRD C.O.**

**3 - 5 TONS**

	NOM. V-Ph-Hz	IFM TYPE	NO C.O. or UNPWR C.O.							
			NO PE.				w/ PE. (pwrd fr/unit)			
			MCA	HACR BRKR	DISC. SIZE		MCA	HACR BRKR	DISC. SIZE	
		FLA	LRA			FLA	LRA			
<b>48LC*004</b>	<b>208/230-3-60</b>	<b>DD-STD</b>	24	30	24	83	26	30	26	85
		<b>STD</b>	24/24	30/30	24/24	100	26/26	30/30	26/26	102
		<b>MED</b>	24/24	30/30	24/24	100	26/26	30/30	26/26	102
		<b>HIGH</b>	26/26	30/30	26/25	104	27/27	30/30	28/27	106
	<b>460-3-60</b>	<b>DD-STD</b>	12	15	12	42	13	15	13	43
		<b>STD</b>	12	15	12	50	13	15	13	51
		<b>MED</b>	12	15	12	50	13	15	13	51
		<b>HIGH</b>	13	15	13	52	14	15	14	53
	<b>575-3-60</b>	<b>DD-STD</b>	10	15	10	30	12	15	12	32
		<b>STD</b>	10	15	9	36	12	15	12	38
		<b>MED</b>	10	15	9	36	12	15	12	38
		<b>HIGH</b>	10	15	10	40	12	15	12	42
<b>48LC*005</b>	<b>208/230-3-60</b>	<b>DD-STD</b>	29	40	29	94	31	40	31	96
		<b>STD</b>	27/27	40/40	27/27	110	29/29	40/40	29/29	112
		<b>MED</b>	27/27	40/40	27/27	110	29/29	40/40	29/29	112
		<b>HIGH</b>	30/30	40/40	30/29	140	32/32	45/45	32/31	142
	<b>460-3-60</b>	<b>DD-STD</b>	14	20	14	46	15	20	15	47
		<b>STD</b>	13	15	12	53	14	15	13	54
		<b>MED</b>	13	15	12	53	14	15	13	54
		<b>HIGH</b>	14	15	13	69	15	20	14	70
	<b>575-3-60</b>	<b>DD-STD</b>	12	15	12	38	14	15	14	40
		<b>STD</b>	10	15	10	43	12	15	12	45
		<b>MED</b>	10	15	10	43	12	15	12	45
		<b>HIGH</b>	12	15	12	56	14	15	14	58
<b>48LC*006</b>	<b>208/230-3-60</b>	<b>DD-STD</b>	32	45	31	121	34	45	33	123
		<b>STD</b>	31/31	45/45	31/30	141	33/33	45/45	33/33	143
		<b>MED</b>	31/31	45/45	31/30	141	33/33	45/45	33/33	143
		<b>HIGH</b>	33/33	45/45	33/32	167	35/35	50/50	35/34	169
	<b>460-3-60</b>	<b>DD-STD</b>	15	20	15	57	16	20	16	58
		<b>STD</b>	15	20	15	66	16	20	16	67
		<b>MED</b>	15	20	15	66	16	20	16	67
		<b>HIGH</b>	15	20	15	80	16	20	16	81
	<b>575-3-60</b>	<b>DD-STD</b>	12	15	12	44	14	20	14	46
		<b>STD</b>	12	15	12	53	14	15	14	55
		<b>MED</b>	12	15	12	53	14	15	14	55
		<b>HIGH</b>	13	15	13	62	15	20	15	64

**48LC**

# MCA/MOCP

	NOM. V-Ph-Hz	IFM TYPE	w/ PWRD C.O.							
			NO P.E.				w/ P.E. (pwrd fr/unit)			
			MCA	HACR BRKR	DISC. SIZE		MCA	HACR BRKR	DISC. SIZE	
		FLA	LRA			FLA	LRA			
48LC*004	208/230-3-60	DD-STD	29	40	30	88	31	40	32	90
		STD	29/29	40/40	30/29	105	31/31	40/40	32/32	107
		MED	29/29	40/40	30/29	105	31/31	40/40	32/32	107
		HIGH	30/30	40/40	31/31	109	32/32	40/40	33/33	111
	460-3-60	DD-STD	-	-	-	-	-	-	-	-
		STD	-	-	-	-	-	-	-	-
		MED	-	-	-	-	-	-	-	-
		HIGH	-	-	-	-	-	-	-	-
	575-3-60	DD-STD	-	-	-	-	-	-	-	-
		STD	-	-	-	-	-	-	-	-
		MED	-	-	-	-	-	-	-	-
		HIGH	-	-	-	-	-	-	-	-
48LC*005	208/230-3-60	DD-STD	34	45	34	99	36	45	36	101
		STD	32/32	45/45	32/32	115	34/34	45/45	35/34	117
		MED	32/32	45/45	32/32	115	34/34	45/45	35/34	117
		HIGH	35/35	45/45	36/35	145	37/37	50/50	38/37	147
	460-3-60	DD-STD	-	-	-	-	-	-	-	-
		STD	-	-	-	-	-	-	-	-
		MED	-	-	-	-	-	-	-	-
		HIGH	-	-	-	-	-	-	-	-
	575-3-60	DD-STD	-	-	-	-	-	-	-	-
		STD	-	-	-	-	-	-	-	-
		MED	-	-	-	-	-	-	-	-
		HIGH	-	-	-	-	-	-	-	-
48LC*006	208/230-3-60	DD-STD	36	50	37	126	38	50	39	128
		STD	36/36	50/50	36/36	146	38/38	50/50	39/38	148
		MED	36/36	50/50	36/36	146	38/38	50/50	39/38	148
		HIGH	38/38	50/50	38/37	172	40/40	50/50	40/39	174
	460-3-60	DD-STD	-	-	-	-	-	-	-	-
		STD	-	-	-	-	-	-	-	-
		MED	-	-	-	-	-	-	-	-
		HIGH	-	-	-	-	-	-	-	-
	575-3-60	DD-STD	-	-	-	-	-	-	-	-
		STD	-	-	-	-	-	-	-	-
		MED	-	-	-	-	-	-	-	-
		HIGH	-	-	-	-	-	-	-	-

Powered Convenience outlet not available on 460 and 575 volt models.

48LC

# TYPICAL WIRING DIAGRAMS

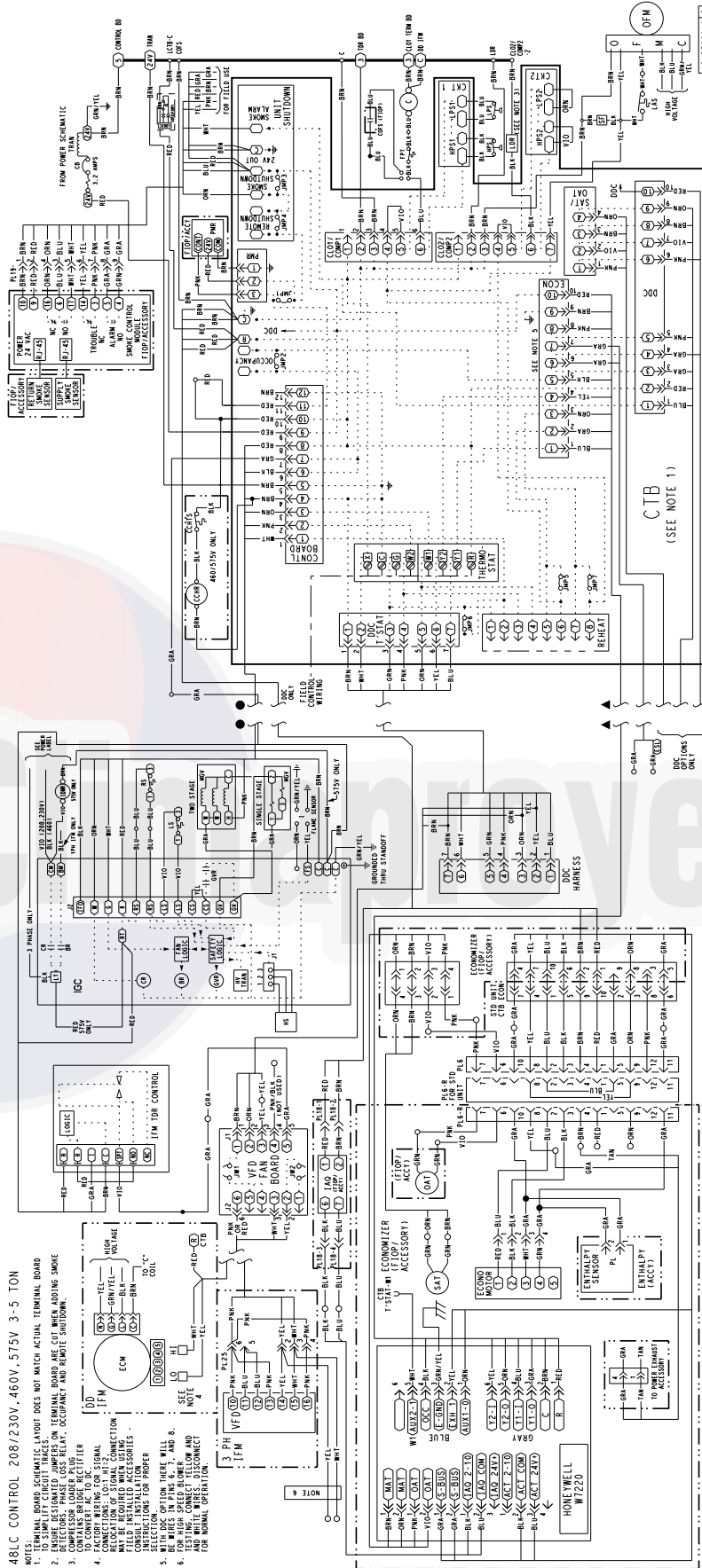

Fig. 11 - 48LC 04-06 Control Wiring Diagram



# SEQUENCE OF OPERATION

## General

The sequence below describes the sequence of operation for an electro-mechanical unit with and without a factory installed EconoMi\$er X (called “economizer” in this sequence). For information regarding a direct digital controller, see the start-up, operations, and troubleshooting manual for the applicable controller.

## Electro-Mechanical Units

- Without Economizer
- With 2-Speed Indoor Fan Motor (Direct Drive Electronically Commutated Motor (ECM) or Belt Drive Motor with Variable Frequency Drive (VFD) Controller)

## Cooling

When Central Terminal Board (CTB) terminal G is energized a 24VAC low speed run signal is sent to the ECM indoor motor or VFD controlled indoor motor through the unit fan board. The indoor fan will operate in low speed setting. High and low speed fan RPM are set by CFM and static pressure requirements for the unit installation. (The ECM and VFD are always energized and only require a 24V low speed or high speed run signal to operate).

When Central Terminal Board (CTB) terminal Y1 is energized (a thermostat call for first stage of cooling), 24VAC power is supplied to compressor contactor C and compressor A1 is energized and runs at part load capacity.

When Central Terminal Board (CTB) terminal Y2 is energized (a thermostat call for second stage of cooling), 24VAC power is supplied to the compressor loader (LDR) and the compressor operates at full load capacity. When Y2 is energized a 24VAC signal is also sent to the fan board and the indoor fan operates at high speed.

Regardless of the number of stages, the outdoor fan motor runs continuously while unit is cooling

At the factory settings during the first stage of cooling operation the ECM indoor motor or VFD controlled indoor motor will adjust the fan motor to provide the CFM required. When a call for the second stage of cooling is required, the ECM indoor motor or VFD controlled indoor motor will run at 100% of the total CFM required for the unit installation.

There is a 75 second indoor fan delay OFF (45 second on the Time Delay Relay (TDR) board and 30 second on the Integrated Gas Controller (IGC)) after the Central Terminal Board (CTB) terminal G is de-energized in the cooling mode

When the outside air temperature falls below 40°F (4°C) the outdoor fan operates at a lower RPM and will allow cooling operation to an outside air temperature of 10°F (-12°C)

## Heating

**NOTE:** WeatherExpert (48LC) units have either 1 or 2 stages of gas heat. When the thermostat calls for heating, power is sent to W on the Integrated Gas Controller (IGC) board. An LED (light-emitting diode) on the IGC board turns on and remains on during normal operation. A check is made to ensure that the rollout switch and limit switch are closed. If the check was successful, the induced draft motor is energized, and when its speed is satisfactory, as proven by the “hall effect” sensor, the ignition activation period begins. The burners will ignite within 5 seconds. If the burners do not light, there is a 22-second delay before another 5 second attempt. This sequence is repeated for 15 minutes or until the burners light. If, after the 15 minutes, the burners still have not lit, heating is locked out. To reset the control, break 24VAC power to the thermostat.

When ignition occurs, the IGC board will continue to monitor the condition of the rollout switch, the limit switches, the “hall effect” sensor, as well as the flame sensor. 45 seconds after ignition occurs, assuming the unit is controlled through a room thermostat set for fan auto, the indoor fan motor will energize and run at full load speed (and the outdoor air dampers will open to their minimum position). If, for some reason, the over temperature limit opens prior to the start of the indoor fan blower, the unit will shorten the 45 second delay to 5 seconds less than the time from initiation of heat to when the limit tripped. Gas will not be interrupted to the burners and heating will continue. Once the fan ON delay has been modified, it will not change back to 45 seconds until power is reset to the control.

On units with 2 stages of heat, when additional heat is required, W2 closes and initiates power to the second stage of the main gas valve. When the thermostat is satisfied, W1 and W2 open and the gas valve closes, interrupting the flow of gas to the main burners. If the call for W1 lasted less than 1 minute, the heating cycle will not terminate until 1 minute after W1 became active. If the unit is controlled through a room thermostat set for fan auto, the indoor fan motor will continue to operate for an additional 45 seconds then stop. If the over temperature limit opens after the indoor motor is stopped, but within 10 minutes of W1 becoming inactive, on the next cycle the time will be extended by 15 seconds. The maximum delay is 3 minutes. Once modified, the fan OFF delay will not change back to 45 seconds unless power is reset to the control. A LED indicator is provided on the IGC to monitor operation

## Electro-Mechanical Units

- With Economizer
- With 2-Speed Indoor Fan Motor (Direct Drive Electronically Commutated Motor (ECM) or Belt Drive Motor with Variable Frequency Drive (VFD) Controller)



## SEQUENCE OF OPERATION (cont.)

### Cooling

When free cooling is not available, the compressors will be controlled by the zone thermostat as described in previous cooling section without economizer.

When free cooling is available, the outdoor air damper is modulated by the EconoMiSer X control to provide a 50°F (10°C) to 55°F (13°C) mixed air temperature into the zone. As the mixed air temperature fluctuates above 55°F (13°C) or below 50°F (10°C) dampers will be modulated (open or close) to bring the mixed air temperature back within control. If mechanical cooling is utilized with free cooling, the outdoor air damper will maintain its current position at the time the compressor is started. If the increase in cooling capacity causes the mixed air temperature to drop below 45°F (7°C), then the outdoor air damper position will be decreased to the minimum position. If the mixed air temperature continues to fall, the outdoor air damper will close. Control returns to normal once the mixed air temperature rises above 48°F (9°C). The power exhaust fans will be energized and de-energized, if installed, as the outdoor air damper opens and closes.

If field installed accessory CO<sub>2</sub> sensors are connected to the EconoMiSer X control, a demand controlled ventilation strategy will begin to operate. As the CO<sub>2</sub> level in the zone increases above the CO<sub>2</sub> set point, the minimum position of the damper will be increased proportionally. As the CO<sub>2</sub> level decreases because of the increase in fresh air, the outdoor air damper will be proportionally closed. For EconoMiSer X operation, there must be a thermostat call for the fan (G). If the unit is occupied and the fan is on, the damper will operate at minimum position. Otherwise, the damper will be closed.

When the EconoMiSer X control is in the occupied mode and a call for cooling exists (Y1 on the thermostat), the control will first check for indoor fan operation. If the fan is not on, then cooling will not be activated. If the fan is on, then the control will open the EconoMiSer X damper to the minimum position.

On the initial power to the EconoMiSer X control, it will take the damper up to 2-1/2 minutes before it begins to position itself. After the initial power-up, further changes in damper position can take up to 30 seconds to initiate. Damper movement from full closed to full open (or vice versa) will take between 1-1/2 and 2-1/2 minutes. If free cooling can be used as determined from the appropriate changeover command (switch, dry bulb, enthalpy curve, differential dry bulb, or differential enthalpy), then the control will modulate the dampers open to maintain the mixed air temperature set point at 50°F (10°C) to 55°F (13°C). If there is a further demand for cooling (cooling second stage -- Y2 is energized), then the control will bring on compressor stage 1 to maintain the mixed air temperature set point. The EconoMiSer X damper will be open at maximum position. EconoMiSer X operation is limited to a single compressor.

2--Speed Note: When operating in ventilation mode only, the indoor fan motor will automatically adjust to part load fan speed set point.

### Optional Humidi-MiZer Dehumidification System

Units with the factory equipped Humidi-MiZer option are capable of providing multiple modes of improved dehumidification as a variation of the normal cooling cycle. The Humidi-MiZer option includes additional valves in the liquid line and discharge line of each refrigerant circuit, a small reheat condenser coil downstream of the evaporator. Operation of the revised refrigerant circuit for each mode is described below.

The Humidi-MiZer system provides three sub-modes of operation: Cooling Mode, Subcooling Mode (Reheat1), and Hot Gas Reheat Mode (Reheat2).

**Normal Cooling Mode** - provides a normal ratio of Sensible and Latent Cooling effect from the evaporator coil.

**Subcooling Mode (Reheat1)** - provides increased Latent Cooling while slightly reducing the Sensible Cooling effect.

**Hot Gas Reheat Mode (Reheat2)** - provides normal Latent Cooling but with null or minimum Sensible Cooling effect delivered to the space.

The Subcooling and Hot Gas Reheat modes are available when the unit is not in a Heating mode and when the Low Ambient Lockout switch is closed.

The following diagrams depict piping for Single Stage cooling units.

### Heating

The sequence of operation for the heating is the same as an electro-mechanical unit with no economizer. The only difference is how the economizer acts. The economizer will stay at the Economizer Minimum Position while the evaporator fan is operating. The outdoor air damper is closed when the indoor fan is not operating.

### Advanced Operation with ComfortLink Controls

#### General

The sequence below appends the sequence of operation for an electromechanical unit with and without a factory installed EconoMiSer. For detailed information regarding direct digital controller operation, see the start-up, operations, and troubleshooting manual.

WeatherExpert (48LC) units ComfortLink controls have multiple fan speeds. Direct drive units have two speeds with an optional third speed. If configured the third speed is used during ventilation operation.

Belt drive VFD units have 5 speeds that the indoor fan will run at based on the running mode and conditioning demand. The 5 speeds are Supply Fan Maximum Speed (100% of balanced airflow), Supply Fan Speed 1, 2, 3, and Supply Fan Speed Ventilation. Supply Fan Speed 2 is pre set to the optimum energy efficiency part load speed. Fan Speed 1 and 3 are pre-set to transition the fan during cooling stage up, and to aid in dehumidification. These 2 speeds can be adjusted in the field to optimize dehumidification, load balancing, or efficiency.



## SEQUENCE OF OPERATION (cont.)

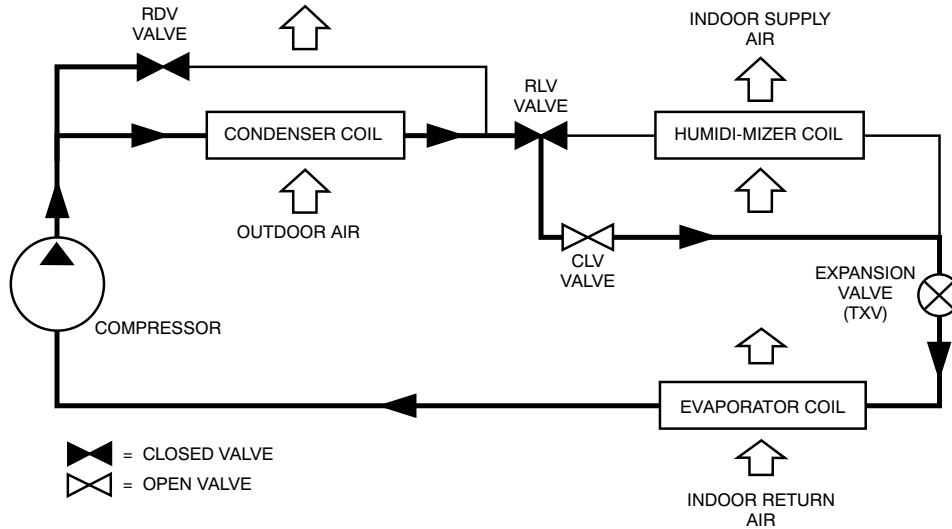

**Fig. 13 - 48LC 04-06 Normal Cooling Mode - Humidi-MiZer System**

C14121

48LC

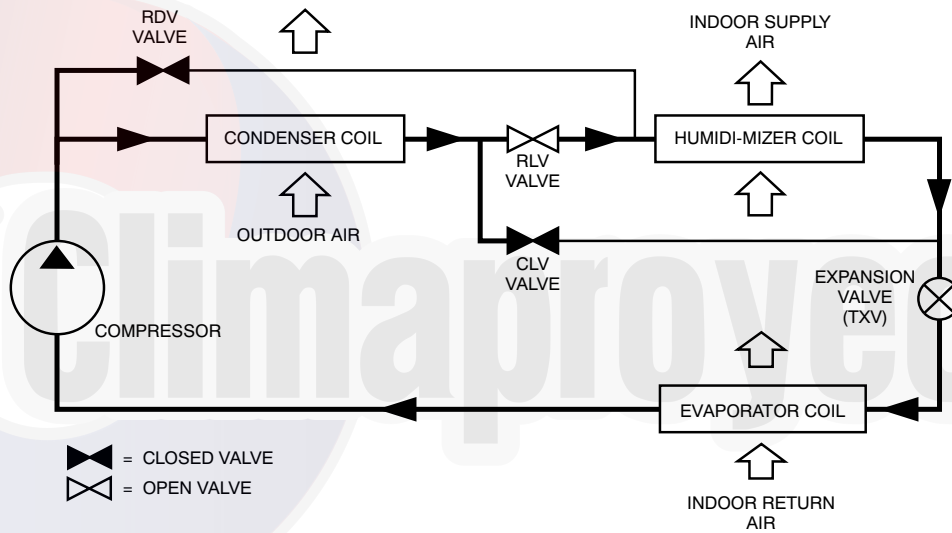

**Fig. 14 - 48LC 04-06 Subcooling Mode (Reheat 1) - Humidi-MiZer System**

C14122

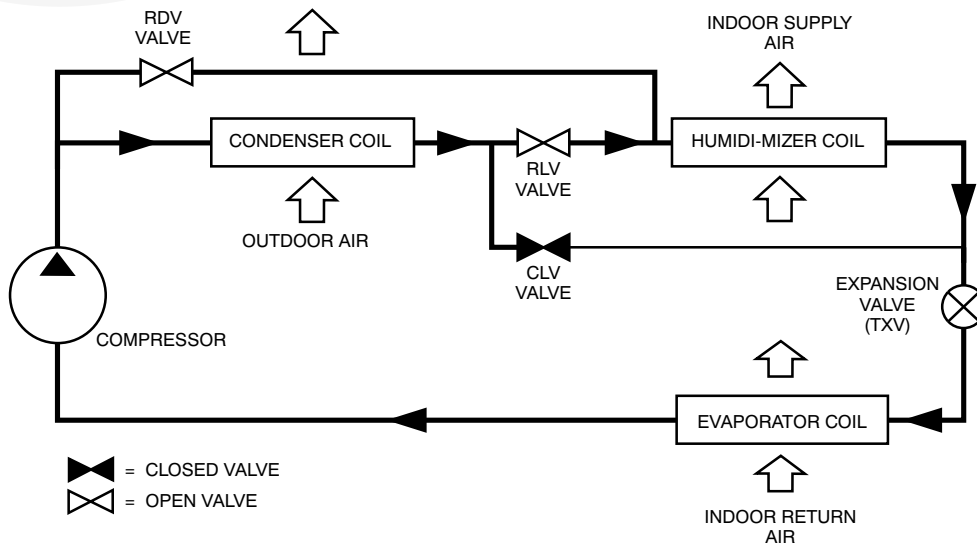

**Fig. 15 - 48LC 04-06 Hot Gas Reheat Mode (Reheat2) - Humidi-MiZer System**

C14123

# GUIDE SPECIFICATIONS - 48LC\*004- 06

Note about this specification:

This specification is in the “Masterformat” as published by the Construction Specification Institute. Please feel free to copy this specification directly into your building spec.

## Gas Heat/Electric Cooling Packaged Rooftop

### HVAC Guide Specifications

Size Range: 3 to 5 Nominal Tons



48LC

<u>Section</u>	<u>Description</u>
----------------	--------------------

<b>23 06 80</b>	<b>Schedules for Decentralized HVAC Equipment</b>
-----------------	---

- |                |   |
|----------------|---|
| 23 06 80.13    | Decentralized Unitary HVAC Equipment Schedule           |
| 23 06 80.13.A. | Rooftop unit schedule                                   |
| 1.             | Schedule is per the project specification requirements. |

<b>23 07 16</b>	<b>HVAC Equipment Insulation</b>
-----------------	----------------------------------

- |                |   |
|----------------|---|
| 23 07 16.13    | Decentralized, Rooftop Units:   |
| 23 07 16.13.A. | Evaporator fan compartment:   |
| 1.             | Interior cabinet surfaces shall be insulated with a minimum 1/2-in. thick, minimum 1 1/2 lb density, flexible fiberglass insulation bonded with a phenolic binder, neoprene coated on the air side. |
| 2.             | Insulation and adhesive shall meet NFPA 90A requirements for flame spread and smoke generation.   |
| 23 07 16.13.B. | Gas heat compartment:   |
| 1.             | Aluminum foil-faced fiberglass insulation shall be used.  |
| 2.             | Insulation and adhesive shall meet NFPA 90A requirements for flame spread and smoke generation.   |

<b>23 09 13</b>	<b>Instrumentation and Control Devices for HVAC</b>
-----------------	---

- |                |   |
|----------------|---|
| 23 09 13.23    | Sensors and Transmitters  |
| 23 09 13.23.A. | Thermostats   |
| 1.             | Thermostat must   |
| a.             | energize both “W” and “G” when calling for heat.  |
| b.             | have capability to energize 2 different stages of cooling, and 2 different stages of heating. |
| c.             | include capability for occupancy scheduling.  |

<b>23 09 23</b>	<b>Direct-digital Control system for HVAC</b>
-----------------	---

- |                |  |
|----------------|--|
| 23 09 23.13    | Decentralized, Rooftop Units:  |
| 23 09 23.13.A. | ComfortLink Unit Controls shall contain:   |
| 1.             | Four button detailed English scrolling marquee display.  |
| 2.             | CCN (Carrier Comfort Network) capable.   |
| 3.             | Unit control with standard suction pressure transducers and condensing temperature thermistors.                        |
| 4.             | Shall provide a 5°F temperature difference between cooling and heating set points to meet ASHRAE 90.1 Energy Standard. |
| 5.             | Shall provide and display a current alarm list and an alarm history list.  |
| 6.             | Service run test capability.   |
| 7.             | Shall accept input from a CO <sub>2</sub> sensor (both indoor and outdoor).  |
| 8.             | Configurable alarm light shall be provided which activates when certain types of alarms occur.                         |
| 9.             | Compressor minimum run time (3 minutes) and minimum off time (5 minutes) are provided.                                 |
| 10.            | Service diagnostic mode.   |

- 11. Economizer control (optional).
- 12. Control multi capacity stages
- 13. Unit shall be complete with self-contained low voltage control circuit.
- 14. Unit shall have 0°F low ambient cooling operation.

23 09 23.13.B. Safeties:

- 1. Unit shall incorporate a solid state compressor lockout that provides optional reset capability at the space thermostat, should any of the following safety devices trip and shut off compressor:
  - a. Compressor lockout protection provided for either internal or external overload.
  - b. Low pressure protection.
  - c. Freeze protection (evaporator coil).
  - d. High pressure protection (high pressure switch or internal).
  - e. Compressor reverse rotation protection
  - f. Loss of charge protection.
  - g. Supply air sensor shall be located in the unit and detect both heating and cooling operation

23 09 23.13.B. RTU Open - multi-protocol, direct digital controller:

- 1. Shall be ASHRAE 62- 2001 compliant.
- 2. Shall accept 18- 30VAC, 50- 60Hz, and consumer 15VA or less power.
- 3. Shall have an operating temperature range from - 40°F (- 40°C) to 130°F (54°C), 10% - 90% RH (non-condensing).
- 4. Shall include built-in protocol for BACNET (MS/TP and PTP modes), Modbus (RTU and ASCII), Johnson N2 and LonWorks. LonWorks Echelon processor required for all Lon applications shall be contained in separate communication board.
- 5. Shall allow access of up to 62 network variables (SNVT). Shall be compatible with all open controllers
- 6. Baud rate Controller shall be selectable using a dipswitch.
- 7. Shall have an LED display independently showing the status of serial communication, running, errors, power, all digital outputs, and all analog inputs.
- 8. Shall accept the following inputs: space temperature, setpoint adjustment, outdoor air temperature, indoor air quality, outdoor air quality, compressor lock-out, fire shutdown, enthalpy switch, and fan status/filter status/humidity/ remote occupancy.
- 9. Shall provide the following outputs: economizer, fan, cooling stage 1, cooling stage 2, heat stage 1, heat stage 2, heat stage 3/ exhaust/ reversing valve.
- 10. Shall have built-in surge protection circuitry through solid state polyswitches. Polyswitches shall be used on incoming power and network connections. Polyswitches will return to normal when the “trip” condition clears.
- 11. Shall have a battery back-up capable of a minimum of 10,000 hours of data and time clock retention during power outages.
- 12. Shall have built-in support for Carrier technician tool.
- 13. Shall include an EIA- 485 protocol communication port, an access port for connection of either a computer or a Carrier technician tool, an EIA- 485 port for network communication to intelligent space sensors and displays, and a port to connect an optional LonWorks communications card.
- 14. Software upgrades will be accomplished by either local or remote download. No software upgrades through chip replacements are allowed.

**23 09 33 Electric and Electronic Control System for HVAC**

23 09 33.13 Decentralized, Rooftop Units:

23 09 33.13.A. General:

- 1. Shall be complete with self-contained low-voltage control circuit protected by a resettable circuit breaker on the 24-v transformer side. Transformer shall have 75VA capability.
- 2. Shall utilize color-coded wiring.
- 3. Shall include a central control terminal board to conveniently and safely provide connection points for vital control functions such as: smoke detectors, phase monitor, gas controller, economizer, thermostat, DDC control options, and low and high pressure switches.
- 4. The heat exchanger shall be controlled by an integrated gas controller (IGC) microprocessor. See heat exchanger section of this specification.
- 5. Unit shall include a minimum of one 8-pin screw terminal connection board for connection of control wiring.

23 09 33.23.B. Safeties:

- 1. Compressor over-temperature, over-current. High internal pressure differential.

2. Low-pressure switch.
  - a. Units with 2 compressors shall have different sized connectors for the circuit 1 and circuit 2 low and high pressure switches. They shall physically prevent the cross-wiring of the safety switches between circuits 1 and 2.
  - b. Low pressure switch shall use different color wire than the high pressure switch. The purpose is to assist the installer and service technician to correctly wire and or troubleshoot the rooftop unit.
3. High-pressure switch.
  - a. Units with 2 compressors shall have different sized connectors for the circuit 1 and circuit 2 low and high pressure switches. They shall physically prevent the cross-wiring of the safety switches between circuits.
  - b. High pressure switch shall use different color wire than the low pressure switch. The purpose is to assist the installer and service technician to correctly wire and or troubleshoot the rooftop unit.
4. Automatic reset, motor thermal overload protector.
5. Heating section shall be provided with the following minimum protections:
  - a. High-temperature limit switches.
  - b. Induced draft motor speed sensor.
  - c. Flame rollout switch.
  - d. Flame proving controls.

### **23 09 93 Sequence of Operations for HVAC Controls**

23 09 93.13 Decentralized, Rooftop Units:

23 09 93.13 INSERT SEQUENCE OF OPERATION

### **23 40 13 Panel Air Filters**

23 40 13.13 Decentralized, Rooftop Units:

23 40 13.13.A. Standard filter section

1. Shall consist of factory-installed, low velocity, disposable 2-in. thick fiberglass filters of commercially available sizes.
2. Unit shall use only one filter size. Multiple sizes are not acceptable.
3. Filters shall be accessible through an access panel with “no-tool” removal as described in the unit cabinet section of this specification (23 81 19.13.H).

### **23 81 19 Self-Contained Air Conditioners**

23 81 19.13 Small-Capacity Self-Contained Air Conditioners (48LC\*\*04-06)

23 81 19.13.A. General

1. Outdoor, rooftop mounted, electrically controlled, heating and cooling unit utilizing a two stage fully hermetic scroll compressor(s) for cooling duty and gas combustion for heating duty.
2. Factory assembled, single-piece heating and cooling rooftop unit. Contained within the unit enclosure shall be all factory wiring, piping, controls, and special features required prior to field start-up.
3. Unit shall use environmentally sound, Puron® refrigerant.
4. Unit shall be installed in accordance with the manufacturer’s instructions.
5. Unit must be selected and installed in compliance with local, state, and federal codes.

23 81 19.13.B. Quality Assurance

1. Unit meets ASHRAE 90.1 minimum efficiency requirements.
2. Units shall be Energy Star certified.
3. Unit shall be rated in accordance with AHRI Standards 210/240 and 340/360.
4. Unit shall be designed to conform to ASHRAE 15, 2001.
5. Unit shall be UL-tested and certified in accordance with ANSI Z21.47 Standards and UL-listed and certified under Canadian standards as a total package for safety requirements.
6. Insulation and adhesive shall meet NFPA 90A requirements for flame spread and smoke generation.
7. Unit casing shall be capable of withstanding 500-hour salt spray exposure per ASTM B117 (scribed specimen).
8. Unit shall be designed in accordance with ISO 9001, and shall be manufactured in a facility registered by ISO 9001.
9. Roof curb shall be designed to conform to NRCA Standards.
10. Unit shall be subjected to a completely automated run test on the assembly line. The data for each unit will be stored at the factory, and must be available upon request.
11. Unit shall be designed in accordance with UL Standard 1995, including tested to withstand rain.

- 12. Unit shall be constructed to prevent intrusion of snow and tested to prevent snow intrusion into the control box up to 40 mph.
- 13. Unit shake tested to assurance level 1, ASTM D4169 to ensure shipping reliability.
- 23 81 19.13.C. Delivery, Storage, and Handling
  - 1. Unit shall be stored and handled per manufacturer's recommendations.
  - 2. Lifted by crane requires either shipping top panel or spreader bars.
  - 3. Unit shall only be stored or positioned in the upright position.
- 23 81 19.13.E. Project Conditions
  - 1. As specified in the contract.
- 23 81 19.13.F. Operating Characteristics
  - 1. Unit shall be capable of starting and running at 125°F (52°C) ambient outdoor temperature, meeting maximum load criteria of AHRI Standard 210/240 at ± 10% voltage.
  - 2. Compressor with standard electrical mechanical controls shall be capable of operation down to 10°F (-12°C), ambient outdoor temperatures. Units with ComfortLink controls shall be available if operation below 0°F (-18°C), is required.
  - 3. Unit shall discharge supply air vertically or horizontally as shown on contract drawings.
  - 4. Unit shall be factory configured for vertical supply & return configurations.
  - 5. Unit shall be field convertible from vertical to horizontal airflow on all models. No special kit required.
  - 6. Unit shall be capable of mixed operation: vertical supply with horizontal return or horizontal supply with vertical return.
- 23 81 19.13.G. Electrical Requirements
  - 1. Main power supply voltage, phase, and frequency must match those required by the manufacturer.
- 23 81 19.13.H. Unit Cabinet
  - 1. Unit cabinet shall be constructed of galvanized steel, and shall be bonderized and coated with a pre-painted baked enamel finish on all externally exposed surfaces.
  - 2. Unit cabinet exterior paint shall be: film thickness, (dry) 0.003 inches minimum, gloss (per ASTM D523, 60°F / 16°C): 60, Hardness: H-2H Pencil hardness.
  - 3. Evaporator fan compartment interior cabinet insulation shall conform to AHRI Standards 210/240 or 340/360 minimum exterior sweat criteria. Interior surfaces shall be insulated with a minimum 1/2-in. thick, 1 lb density, flexible aluminum foil faced insulation on all interior air stream panels.
  - 4. Base of unit shall have a minimum of four locations for thru-the-base gas and electrical connections (factory installed or field installed), standard.
  - 5. Base Rail
    - a. Unit shall have base rails on a minimum of 4 sides.
    - b. Holes shall be provided in the base rails for rigging shackles to facilitate maneuvering and overhead rigging.
    - c. Holes shall be provided in the base rail for moving the rooftop by fork truck.
    - d. Base rail shall be a minimum of 16 gauge thickness.
  - 6. Condensate pan and connections:
    - a. Shall be an internally sloped condensate drain pan made of a non-corrosive material.
    - b. Shall comply with ASHRAE Standard 62.
    - c. Shall use a 3/4-IN - 14 NPT drain connection, possible either through the bottom or side of the drain pan. Connection shall be made per manufacturer's recommendations.
  - 7. Top panel:
    - a. Shall be a single piece top panel on all models.
  - 8. Gas Connections:
    - a. All gas piping connecting to unit gas valve shall enter the unit cabinet at a single location on side of unit (horizontal plane).
    - b. Thru-the-base capability
      - (1.) Standard unit shall have a thru-the-base gas-line location using a raised, embossed portion of the unit basepan.
      - (2.) Optional, factory-approved, water-tight connection method must be used for thru-the-base gas connections.
      - (3.) No basepan penetration, other than those authorized by the manufacturer, is permitted.
  - 9. Electrical Connections

- a. All unit power wiring shall enter unit cabinet at a single, factory-prepared, knockout location.
  - b. Thru-the-base capability.
    - (1.) Standard unit shall have a thru-the-base electrical location(s) using a raised, embossed portion of the unit basepan.
    - (2.) Optional, factory-approved, water-tight connection method must be used for thru-the-base electrical connections.
    - (3.) No basepan penetration, other than those authorized by the manufacturer, is permitted.
10. Component access panels (standard)
- a. Cabinet panels shall be easily removable for servicing.
  - b. Unit shall have one factory installed, tool-less, removable, filter access panel.
  - c. Panels covering control box, indoor fan, indoor fan motor, gas components (where applicable), and compressors shall have a molded composite handles.
  - d. Handles shall be UV modified, composite. They shall be permanently attached, and recessed into the panel.
  - e. Screws on the vertical portion of all removable access panel shall engage into heat resistant, molded composite collars.
  - f. Collars shall be removable and easily replaceable using manufacturer recommended parts.

23 81 19.13.I. Gas Heat

1. General
  - a. Heat exchanger shall be an induced draft design. Positive pressure heat exchanger designs shall not be allowed.
  - b. Shall incorporate a direct-spark ignition system and redundant main gas valve.
  - c. Gas supply pressure at the inlet to the rooftop unit gas valve must match that required by the manufacturer.
2. The heat exchanger shall be controlled by an integrated gas controller (IGC) microprocessor.
  - a. IGC board shall notify users of fault using an LED (light-emitting diode).
  - b. The LED shall be visible without removing the control box access panel.
  - c. IGC board shall contain algorithms that modify evaporator-fan operation to prevent future cycling on high temperature limit switch.
  - d. Unit shall be equipped with anti-cycle protection with one short cycle on unit flame rollout switch or 4 continuous short cycles on the high temperature limit switch. Fault indication shall be made using an LED.
3. Standard Heat Exchanger construction
  - a. Heat exchanger shall be of the tubular-section type constructed of a minimum of 20-gauge steel coated with a nominal 1.2 mil aluminum-silicone alloy for corrosion resistance.
  - b. Burners shall be of the in-shot type constructed of aluminum-coated steel.
  - c. Burners shall incorporate orifices for rated heat output up to 2000 ft (610m) elevation. Additional accessory kits may be required for applications above 2000 ft (610m) elevation, depending on local gas supply conditions.
  - d. Each heat exchanger tube shall contain multiple dimples for increased heating effectiveness.
4. Optional Stainless Steel Heat Exchanger construction
  - a. Use energy saving, direct-spark ignition system.
  - b. Use a redundant main gas valve.
  - c. Burners shall be of the in-shot type constructed of aluminum-coated steel.
  - d. All gas piping shall enter the unit cabinet at a single location on side of unit (horizontal plane).
  - e. The optional stainless steel heat exchanger shall be of the tubular-section type, constructed of a minimum of 20-gauge type 409 stainless steel.
  - f. Type 409 stainless steel shall be used in heat exchanger tubes and vestibule plate.
  - g. Complete stainless steel heat exchanger allows for greater application flexibility.
5. Optional Low NO<sub>x</sub> Heat Exchanger construction
  - a. Low NO<sub>x</sub> reduction shall be provided to reduce nitrous oxide emissions to meet California's Air Quality Management District (SCAQMD) low-NO<sub>x</sub> emissions requirement of 40 nanograms per joule or less.
  - b. Primary tubes and vestibule plates on low NO<sub>x</sub> units shall be 409 stainless steel. Other components shall be aluminized steel.
6. Induced draft combustion motor and blower
  - a. Shall be a direct-drive, single inlet, forward-curved centrifugal type.
  - b. Shall be made from steel with a corrosion-resistant finish.
  - c. Shall have permanently lubricated sealed bearings.



- d. Shall have inherent thermal overload protection.
- e. Shall have an automatic reset feature.

23 81 19.13.J. Coils

1. Standard Aluminum Fin/Copper Tube Coils:
  - a. Standard evaporator and condenser coils shall have aluminum lanced plate fins mechanically bonded to seamless internally grooved copper tubes with all joints brazed.
  - b. Evaporator coils shall be leak tested to 150 psig, pressure tested to 450 psig, and qualified to UL 1995 burst test at 1775 psig.
  - c. Condenser coils shall be leak tested to 150 psig, pressure tested to 650 psig, and qualified to UL 1995 burst test at 1980 psig.
2. Optional Pre-coated aluminum-fin condenser coils:
  - a. Shall have a durable epoxy-phenolic coating to provide protection in mildly corrosive coastal environments.
  - b. Coating shall be applied to the aluminum fin stock prior to the fin stamping process to create an inert barrier between the aluminum fin and copper tube.
  - c. Epoxy-phenolic barrier shall minimize galvanic action between dissimilar metals.
3. Optional Copper-fin evaporator and condenser coils:
  - a. Shall be constructed of copper fins mechanically bonded to copper tubes and copper tube sheets.
  - b. Galvanized steel tube sheets shall not be acceptable.
  - c. A polymer strip shall prevent coil assembly from contacting the sheet metal coil pan to minimize potential for galvanic corrosion between coil and pan.
4. Optional E-coated aluminum-fin evaporator and condenser coils:
  - a. Shall have a flexible epoxy polymer coating uniformly applied to all coil surface areas without material bridging between fins.
  - b. Coating process shall ensure complete coil encapsulation of tubes, fins and headers.
  - c. Color shall be high gloss black with gloss per ASTM D523-89.
  - d. Uniform dry film thickness from 0.8 to 1.2 mil on all surface areas including fin edges.
  - e. Superior hardness characteristics of 2H per ASTM D3363-92A and cross-hatch adhesion of 4B-5B per ASTM D3359-93.
  - f. Impact resistance shall be up to 160 in.-lb (ASTM D2794-93).
  - g. Humidity and water immersion resistance shall be up to minimum 1000 and 250 hours respectively (ASTM D2247-92 and ASTM D870-92).
  - h. Corrosion durability shall be confirmed through testing to be no less than 1000 hours salt spray per ASTM B117-90.
5. Optional E-coated aluminum-fin, aluminum tube condenser coils:
  - a. Shall have a flexible epoxy polymer coating uniformly applied to all coil external surface areas without material bridging between fins or louvers.
  - b. Coating process shall ensure complete coil encapsulation, including all exposed fin edges.
  - c. E-coat thickness of 0.8 to 1.2 mil with top coat having a uniform dry film thickness from 1.0 to 2.0 mil on all external coil surface areas, including fin edges, shall be provided.
  - d. Shall have superior hardness characteristics of 2H per ASTM D3363-00 and cross-hatch adhesion of 4B-5B per ASTM D3359-02.
  - e. Shall have superior impact resistance with no cracking, chipping or peeling per NSF/ANSI 51-2002 Method 10.2.

23 81 19.13.K. Refrigerant Components

1. Refrigerant circuit shall include the following control, safety, and maintenance features:
  - a. Thermostatic Expansion Valve (TXV) shall help provide optimum performance across the entire operating range. Shall contain removable power element to allow change out of power element and bulb without removing the valve body.
  - b. Refrigerant filter drier - Solid core design.
  - c. Service gauge connections on suction and discharge lines.
  - d. Pressure gauge access through a specially designed access port in the top panel of the unit.
2. There shall be gauge line access port in the skin of the rooftop, covered by a black, removable plug.
  - a. The plug shall be easy to remove and replace.

- b. When the plug is removed, the gauge access port shall enable maintenance personnel to route their pressure gauge lines.
  - c. This gauge access port shall facilitate correct and accurate condenser pressure readings by enabling the reading with the compressor access panel on.
  - d. The plug shall be made of a leak proof, UV-resistant, composite material.
3. Compressors
- a. Unit shall use fully hermetic, scroll compressor for each independent refrigeration circuit.
  - b. Models shall be available with two stage capacity control.
  - c. Compressor motors shall be cooled by refrigerant gas passing through motor windings.
  - d. Compressors shall be internally protected from high discharge temperature conditions.
  - e. Compressors shall be protected from an over-temperature and over-amperage conditions by an internal, motor overload device.
  - f. Compressor shall be factory mounted on rubber grommets.
  - g. Compressor motors shall have internal line break thermal, current overload and high pressure differential protection.
  - h. Crankcase heaters shall be standard on each compressor.

23 81 19.13.L. Filter Section

- 1. Filters access is specified in the unit cabinet section of this specification.
- 2. Filters shall be held in place by a pivoting filter tray, facilitating easy removal and installation.
- 3. Shall consist of factory-installed, low velocity, throw-away 2-in. thick fiberglass filters.
- 4. Filters shall be standard, commercially available sizes.
- 5. Only one size filter per unit is allowed.

23 81 19.13.M. Evaporator Fan and Motor

- 1. Evaporator fan motor:
  - a. Shall have permanently lubricated bearings.
  - b. Shall have inherent automatic-reset thermal overload protection or circuit breaker.
  - c. Shall have a maximum continuous bhp rating for continuous duty operation; no safety factors above that rating shall be required.
- 2. ECM Direct Drive (Multi-Speed) Evaporator Fan Motor:
  - a. Multi-speed motor with easy quick adjustment settings.
  - b. Blower fan shall be double-inlet type with forward-curved blades.
  - c. Shall be constructed from steel with a corrosion resistant finish and dynamically balanced.
  - d. Standard on all all models
- 3. Optional Belt-driven Evaporator Fan with VFD controller and display:
  - a. Belt drive shall include an adjustable-pitch motor pulley.
  - b. Shall use sealed, permanently lubricated ball-bearing type.
  - c. Blower fan shall be double-inlet type with forward-curved blades.
  - d. Shall be constructed from steel with a corrosion resistant finish and dynamically balanced.
  - e. Shall come with factory installed Variable Frequency Drive (VFD):
    - (1.) Shall be installed inside the unit cabinet, mounted, wired and tested
    - (2.) Shall contain Electromagnetic Interference (EMI) suppression (also called radio frequency interference or RFI) that may interrupt, obstruct, or otherwise degrade the effective performance of the internal circuit.
    - (3.) Insulated Gate Bi-Polar Transistors (IGBT) used to produce the output pulse width modulated (PWM) waveform, allowing for quiet motor operation.
    - (4.) Be self diagnostics
    - (5.) RS485 capability standard.
    - (6.) Electronic thermal overload protection.
    - (7.) 5% swinging chokes for harmonic reduction and improved power factor.
    - (8.) All printed circuit boards shall be conformal coated

23 81 19.13.N. Condenser Fans and Motors

- 1. Condenser fan motors:
  - a. Shall be a totally enclosed motor.
  - b. Shall use permanently lubricated bearings.

- c. Shall have inherent thermal overload protection with an automatic reset feature.
  - d. Shall use a shaft-down design.
  - e. Shall be ECM design.
2. Condenser Fans:
- a. Shall be a direct-driven propeller type fan.
  - b. Shall have aluminum blades riveted to corrosion-resistant steel spiders and shall be dynamically balanced.

23 81 19.13.O. Special Features Options and Accessories

1. Integrated EconoMi\$er2, and EconoMi\$er X standard leak rate models
- a. Integrated, gear driven opposing modulating blade design type capable of simultaneous economizer and compressor operation.
  - b. Independent modules for vertical or horizontal return configuration shall be available. Vertical return modules shall be available as a factory installed option.
  - c. Damper blades shall be galvanized steel with composite gears. Plastic or composite blades on intake or return shall not be acceptable.
  - d. Shall include all hardware and controls to provide free cooling with outdoor air when temperature and/or humidity are below setpoints.
  - e. Shall be equipped with gear driven dampers for both the outdoor ventilation air and the return air for positive air stream control.
  - f. Standard leak rate models shall be equipped with leakage dampers, not to exceed 2% leakage at 1 in. wg pressure differential.
  - g. Economizer controller on EconoMi\$er X models shall be the Honeywell W7220 that provides:
    - (1.) 2-line LCD interface screen for setup, configuration and troubleshooting
    - (2.) On-board Fault Detection and Diagnostics (FDD) that senses and alerts when the economizer is not operating properly, per California Title 24.
    - (3.) Sensor failure loss of communication identification
    - (4.) Automatic sensor detection
    - (5.) Capabilities for use with multiple-speed indoor fan systems
    - (6.) Utilize digital sensors: Dry bulb and Enthalpy
  - h. Economizer controller on EconoMi\$er2 models with RTU Open models shall be a 4-20mA design controlled directly by the RTU Open controller. RTU Open meets California Title 24 Fault Detection & Diagnostic (FDD) requirements.
  - i. Economizer controller on EconoMi\$er2 models with ComfortLink models shall be controlled directly by the ComfortLink controller. ComfortLink meets California Title 24 Fault Detection & Diagnostic (FDD) requirements.
  - j. Shall be capable of introducing up to 100% outdoor air.
  - k. Shall be equipped with a barometric relief damper capable of relieving up to 100% return air and contain seals that meet ASHRAE 90.1 requirements.
    - l. Shall be designed to close damper(s) during loss-of-power situations with spring return built into motor.
  - m. Dry bulb outdoor air temperature sensor shall be provided as standard. Enthalpy sensor is also available on factory installed only. Outdoor air sensor setpoint shall be adjustable and shall range from 40 to 100°F / 4 to 38°C. Additional sensor options shall be available as accessories.
  - n. The economizer controller shall also provide control of an accessory power exhaust unit function. Factory set at 100%, with a range of 0% to 100%.
  - o. The economizer shall maintain minimum airflow into the building during occupied period and provide design ventilation rate for full occupancy.
  - p. Dampers shall be completely closed when the unit is in the unoccupied mode
  - q. Economizer controller shall accept a 2-10 Vdc CO<sub>2</sub> sensor input for IAQ/DCV control. In this mode, dampers shall modulate the outdoor air damper to provide ventilation based on the sensor input.
  - r. Compressor lockout temperature on W7220 is adjustable from -45 to 80F, set at a factory default of 32°F. Others shall open at 35°F (2C) and closes at 50°F (10°C).
  - s. Actuator shall be direct coupled to economizer gear. No linkage arms or control rods shall be acceptable.
  - t. Economizer controller shall provide indications when in free cooling mode, in the DCV mode, or the exhaust fan contact is closed.
2. Integrated EconoMi\$er2, and EconoMi\$er X Ultra Low Leak Models
- a. Integrated, gear driven opposing modulating blade design type capable of simultaneous economizer and compressor operation.

- b. Independent modules for vertical or horizontal return configuration shall be available. Vertical return modules shall be available as a factory installed option.
  - c. Damper blades shall be galvanized steel with composite gears. Plastic or composite blades on intake or return shall not be acceptable.
  - d. Shall include all hardware and controls to provide free cooling with outdoor air when temperature and/or humidity are below setpoints.
  - e. Shall be equipped with gear driven dampers for both the outdoor ventilation air and the return air for positive air stream control.
  - f. Ultra Low Leak design meets California Title 24 section 140.4 and ASHRAE 90.1 requirements of 4cfm per sq. ft. on the outside dampers and 10cfm per sq. ft. on the return dampers.
  - g. Economizer controller on EconoMiSer X models shall be the Honeywell W7220 that provides:
    - (1.) 2-line LCD interface screen for setup, configuration and troubleshooting
    - (2.) On-board Fault Detection and Diagnostics (FDD) that senses and alerts when the economizer is not operating properly, per California Title 24.
    - (3.) Sensor failure loss of communication identification
    - (4.) Automatic sensor detection
    - (5.) Capabilities for use with multiple-speed indoor fan systems
    - (6.) Utilize digital sensors: Dry bulb and Enthalpy
  - h. Economizer controller on EconoMiSer2 models with RTU Open models shall be a 4-20mA design controlled directly by the RTU Open controller. RTU Open meets California Title 24 Fault Detection & Diagnostic (FDD) requirements.
  - i. Economizer controller on EconoMiSer2 models with ComfortLink models shall be controlled directly by the ComfortLink controller. ComfortLink meets California Title 24 Fault Detection & Diagnostic (FDD) requirements.
  - j. Shall be capable of introducing up to 100% outdoor air.
  - k. Shall be equipped with a barometric relief damper capable of relieving up to 100% return air and contain seals that meet ASHRAE 90.1 requirements.
    - l. Shall be designed to close damper(s) during loss-of-power situations with spring return built into motor.
  - m. Dry bulb outdoor air temperature sensor is also available on factory installed only. Outdoor air sensor setpoint shall be adjustable and shall range from 40 to 100°F / 4 to 38°C. Additional sensor options shall be available as accessories.
  - n. The economizer controller shall also provide control of an accessory power exhaust unit function. Factory set at 100%, with a range of 0% to 100%.
  - o. The economizer shall maintain minimum airflow into the building during occupied period and provide design ventilation rate for full occupancy.
  - p. Dampers shall be completely closed when the unit is in the unoccupied mode.
  - q. Economizer controller shall accept a 2- 10 Vdc CO<sub>2</sub> sensor input for IAQ/DCV control. In this mode, dampers shall modulate the outdoor air damper to provide ventilation based on the sensor input.
  - r. Compressor lockout temperature on W7220 is adjustable from -45 F to 80 F, set at a factory default of 32°F. Others shall open at 35°F (2C) and closes at 50°F (10°C).
  - s. Actuator shall be direct coupled to economizer gear. No linkage arms or control rods shall be acceptable.
  - t. Economizer controller shall provide indications when in free cooling mode, in the DCV mode, or the exhaust fan contact is closed.
3. Propane Conversion Kit
    - a. Package shall contain all the necessary hardware and instructions to convert a standard natural gas unit for use with liquefied propane, up to 2000 ft (610m) elevation.
    - b. Additional accessory kits may be required for applications above 2000 ft (610m) elevation.
  4. Flue Shield
    - a. Flue shield shall provide protection from the hot sides of the gas flue hood.
  5. Condenser Coil Hail Guard Assembly:
    - a. Shall protect against damage from hail.
    - b. Shall be of louvered style.
  6. Unit-Mounted, Non-Fused Disconnect Switch:
    - a. Switch shall be factory-installed, internally mounted.
    - b. National Electric Code (NEC) and UL approved non-fused switch shall provide unit power shutoff.
    - c. Shall be accessible from outside the unit.

- d. Shall provide local shutdown and lockout capability.
7. Convenience Outlet:
  - a. Powered convenience outlet (not available on 575 volt models).
    - (1.) Outlet shall be powered from main line power to the rooftop unit.
    - (2.) Outlet shall be powered from line side or load side of disconnect by installing contractor, as required by code. If outlet is powered from load side of disconnect, unit electrical ratings shall be UL certified and rated for additional outlet amperage.
    - (3.) Outlet shall be factory-installed and internally mounted with easily accessible 115-v female receptacle.
    - (4.) Outlet shall include 15 amp GFI receptacles with independent fuse protection.
    - (5.) Voltage required to operate convenience outlet shall be provided by a factory-installed step-down transformer.
    - (6.) Outlet shall be accessible from outside the unit.
    - (7.) Outlet shall include a field-installed "Wet in Use" cover.
  - b. Non-Powered convenience outlet.
    - (1.) Outlet shall be powered from a separate 115/120v power source.
    - (2.) A transformer shall not be included.
    - (3.) Outlet shall be factory-installed and internally mounted with easily accessible 115-v female receptacle.
    - (4.) Outlet shall include 15 amp GFI receptacles with independent fuse protection.
    - (5.) Outlet shall be accessible from outside the unit.
    - (6.) Outlet shall include a field-installed "Wet in Use" cover.
8. Flue Discharge Deflector:
  - a. Flue discharge deflector shall direct unit exhaust vertically instead of horizontally.
  - b. Deflector shall be defined as a "natural draft" device by the National Fuel and Gas (NFG) code.
9. Thru-the-Base Connectors:
  - a. Kits shall provide connectors to permit gas and electrical connections to be brought to the unit through the unit basepan.
  - b. Minimum of four connection locations per unit.
10. Propeller Power Exhaust:
  - a. Power exhaust shall be used in conjunction with an integrated economizer.
  - b. Independent modules for vertical or horizontal return configurations shall be available.
  - c. Horizontal power exhaust is shall be mounted in return ductwork.
  - d. Power exhaust shall be controlled by economizer controller operation. Exhaust fans shall be energized when dampers open past the 0-100% adjustable setpoint on the economizer control.
11. Roof Curbs (Vertical):
  - a. Full perimeter roof curb with exhaust capability providing separate air streams for energy recovery from the exhaust air without supply air contamination.
  - b. Formed galvanized steel with wood nailer strip and shall be capable of supporting entire unit weight.
  - c. Permits installation and securing of ductwork to curb prior to mounting unit on the curb.
12. High Altitude Gas Conversion Kit:
  - a. Package shall contain all the necessary hardware and instructions to convert a standard natural gas unit to operate from 2000-7000 ft (610 to 2134m) elevation with natural gas or from 0-7000 ft (90-2134m) elevation with liquefied propane.
13. Outdoor Air Enthalpy Sensor:
  - a. The outdoor air enthalpy sensor shall be used to provide single enthalpy control. When used in conjunction with a return air enthalpy sensor, the unit will provide differential enthalpy control. The sensor allows the unit to determine if outside air is suitable for free cooling.
14. Return Air Enthalpy Sensor:
  - a. The return air enthalpy sensor shall be used in conjunction with an outdoor air enthalpy sensor to provide differential enthalpy control.
15. Indoor Air Quality (CO<sub>2</sub>) Sensor:
  - a. Shall be able to provide demand ventilation indoor air quality (IAQ) control.
  - b. The IAQ sensor shall be available in duct mount, wall mount, or wall mount with LED display. The setpoint shall have adjustment capability.



16. Smoke detectors (factory-installed only):
  - a. Shall be a Four-Wire Controller and Detector.
  - b. Shall be environmental compensated with differential sensing for reliable, stable, and drift-free sensitivity.
  - c. Shall use magnet-activated test/reset sensor switches.
  - d. Shall have tool-less connection terminal access.
  - e. Shall have a recessed momentary switch for testing and resetting the detector.
  - f. Controller shall include:
    - (1.) One set of normally open alarm initiation contacts for connection to an initiating device circuit on a fire alarm control panel.
    - (2.) Two Form-C auxiliary alarm relays for interface with rooftop unit or other equipment.
    - (3.) One Form-C supervision (trouble) relay to control the operation of the Trouble LED on a remote test/reset station.
    - (4.) Capable of direct connection to two individual detector modules.
    - (5.) Can be wired to up to 14 other duct smoke detectors for multiple fan shutdown applications
17. Time Guard
  - a. Shall prevent compressor short cycling by providing a 5-minute delay ( $\pm 2$  minutes) before restarting a compressor after shutdown for any reason.
  - b. One device shall be required per compressor.
18. Hinged Access Panels
  - a. Shall provide easy access through integrated quarter turn latches and lift tabs.
  - b. Shall be on major panels of – filter, control box, fan motor and compressor.
19. Humidi-MiZer<sup>®</sup> Adaptive Dehumidification System (not available with ComfortLink Controls):
  - a. The Humidi-MiZer Adaptive Dehumidification System shall be factory installed, certified and tested to provide greater dehumidification of the occupied space by providing two distinct modes of dehumidification operation in addition to its normal design cooling mode:
    - (1.) Subcooling mode further sub-cools the hot liquid refrigerant leaving the condenser coil as well as re-heat leaving air stream. It can provide both better cooling capacity as well as dehumidification process when both temperature and humidity in the space are not satisfied.
    - (2.) Hot gas reheat mode shall mix a portion of hot gas from the discharge of the compressor with the hot liquid refrigerant leaving the condenser coil to create a two-phase warm refrigerant in the reheat coil which results in a neutral leaving air temperature when only humidity in the space is not satisfied.