



Installation Instructions

NOTE: Read the entire instruction manual before starting the installation.

SAFETY CONSIDERATIONS 1

GENERAL 3

Rated Indoor Airflow (cfm) 3

INSTALLATION 9

Jobsite Survey 9

Step 1 — Plan for Unit Location 9

- ROOF MOUNT

Step 2 — Plan for Sequence of Unit Installation .. 10

- CURB-MOUNTED INSTALLATION
- PAD-MOUNTED INSTALLATION
- FRAME-MOUNTED INSTALLATION

Step 3 — Inspect Unit 10

Step 4 — Provide Unit Support 10

- ROOF CURB MOUNT
- SLAB MOUNT (HORIZONTAL UNITS ONLY)
- ALTERNATE UNIT SUPPORT (IN LIEU OF CURB OR SLAB MOUNT)

Step 5 — Field Fabricate Ductwork 12

Step 6 — Rig and Place Unit 12

- POSITIONING ON CURB

Step 7 — Convert to Horizontal and Connect Ductwork (when required) 13

Step 8 — Install Outside Air Hood 14

- ECONOMIZER HOOD REMOVAL AND SETUP – FACTORY OPTION
- ECONOMIZER HOOD ASSEMBLY

Step 9 — Install Flue Hood 15

Step 10 — Install Gas Piping 15

- FACTORY-OPTION THRU-BASE CONNECTIONS (GAS CONNECTION)

Step 11 — Install External Condensate Trap and Line 18

Step 12 — Make Electrical Connections 18

- FIELD POWER SUPPLY
- ALL UNITS
- UNITS WITHOUT FACTORY-INSTALLED NON-FUSED DISCONNECT OR HACR
- UNITS WITH FACTORY-INSTALLED NON-FUSED DISCONNECT OR HACR
- CONVENIENCE OUTLETS
- HACR
- FACTORY-OPTION THRU-BASE CONNECTIONS (ELECTRICAL CONNECTIONS)
- UNITS WITHOUT THRU-BASE CONNECTIONS
- FIELD CONTROL WIRING
- THERMOSTAT
- UNIT WITHOUT THRU-BASE CONNECTION KIT
- HEAT ANTICIPATOR SETTINGS

Humidi-MiZer® System Control Connections 30

- HUMIDI-MIZER SYSTEM – SPACE RH CONTROLLER

RTU Open Controller (Factory-Installed Option) .. 31

SystemVu™ Controller (Factory-Installed Option) .31

Integrated Staging Control (ISC) Board32

- ISC BOARD - SEQUENCE OF OPERATION

EconoMiZer® X (Factory Option)34

- SYSTEM COMPONENTS
- SPECIFICATIONS
- INPUTS
- OUTPUTS
- ENVIRONMENTAL
- ECONOMIZER MODULE WIRING DETAILS
- INTERFACE OVERVIEW
- SETUP AND CONFIGURATION
- ENTHALPY SETTINGS
- TWO-SPEED FAN OPERATION
- CHECKOUT
- TROUBLESHOOTING

Staged Air Volume (SAV™) with Variable Frequency Drive48

Multi-Speed VFD Display Kit (Field-Installed Accessory)48

- ALPHA NUMERIC DISPLAY
- MENU KEY
- NAVIGATION KEYS AND STATUS LEDS
- OPERATION KEYS AND LEDS
- CONNECTING THE KEYPAD TO THE VFD
- PROGRAM THE VFD FOR 3 DISCRETE INDOOR FAN SPEEDS

Smoke Detectors59

- COMPLETING INSTALLATION OF RETURN-AIR SMOKE SENSOR
- ADDITIONAL APPLICATION DATA

Step 13 — Adjust Factory-Installed Options60

- SMOKE DETECTORS

Step 14 — Install Accessories60

Step 15 — Check Belt Tension60

- BELT FORCE — DEFLECTION METHOD
- BELT TENSION METHOD

START-UP CHECKLISTCL-1

SAFETY CONSIDERATIONS

Improper installation, adjustment, alteration, service, maintenance, or use can cause explosion, fire, electrical shock or other conditions which may cause personal injury or property damage. Consult a qualified installer, service agency, or your distributor or branch for information or assistance. The qualified installer or agency must use factory-authorized kits or accessories when modifying this product. Refer to the individual instructions packaged with the kits or accessories when installing.

Follow all safety codes. Wear safety glasses and work gloves. Use quenching cloths for brazing operations and have a fire extinguisher available. Read these instructions thoroughly and follow all warnings or cautions attached to the unit. Consult local building codes and appropriate national electrical codes (in USA,

ANSI/NFPA70, National Electrical Code (NEC); in Canada, CSA C22.1) for special requirements.

It is important to recognize safety information. This is the safety-alert symbol . When you see this symbol on the unit and in instructions or manuals, be alert to the potential for personal injury.

Understand the signal words DANGER, WARNING, CAUTION, and NOTE. These words are used with the safety-alert symbol. DANGER identifies the most serious hazards which **will** result in severe personal injury or death. WARNING signifies hazards which **could** result in personal injury or death. CAUTION is used to identify unsafe practices, which **may** result in minor personal injury or product and property damage. NOTE is used to highlight suggestions which **will** result in enhanced installation, reliability, or operation.

 **WARNING**

FIRE, EXPLOSION HAZARD

Failure to follow this warning could result in serious personal injury, death, and/or property damage.

Disconnect gas piping from unit when leak testing at pressure greater than 0.5 psig (3450 Pa). Pressures greater than 0.5 psig (3450 Pa) will cause gas valve damage resulting in hazardous condition. If gas valve is subjected to pressure greater than 0.5 psig (3450 Pa), it must be replaced before use. When pressure testing field-supplied gas piping at pressures of 0.5 psig (3450 Pa) or less, a unit connected to such piping must be isolated by closing the manual gas valve(s).

 **WARNING**

CARBON-MONOXIDE POISONING HAZARD

Failure to follow instructions could result in severe personal injury or death due to carbon-monoxide poisoning, if combustion products infiltrate into the building.

Check that all openings in the outside wall around the vent (and air intake) pipe(s) are sealed to prevent infiltration of combustion products into the building.

Check that furnace vent (and air intake) terminal(s) are not obstructed in any way during all seasons.

 **AVERTISSEMENT**

RISQUE D'INTOXICATION AU MONOXYDE DE CARBONE

Si ces directives ne sont pas suivies, cela peut entraîner des blessures graves ou une intoxication au monoxyde de carbone pouvant causer la mort, si des produits de combustion s'infiltrent dans le bâtiment.

Vérifier que toutes les ouvertures pratiquées dans le mur extérieur autour du ou des tuyaux d'évent (et de la prise d'air) sont scellées de manière à empêcher l'infiltration de produits de combustion dans le bâtiment.

Veiller à ce que la ou les sorties de l'évent de l'appareil de chauffage (et la prise d'air) ne soient, en aucune façon, obstruées, quelle que soit la saison.

 **DANGER**

ELECTRICAL SHOCK HAZARD

Failure to follow this warning will result in personal injury or death.

Before performing service or maintenance operations on unit, turn off main power switch to unit and install lock(s) and lock-out tag(s). Ensure electrical service to rooftop unit agrees with voltage and amperage listed on the unit rating plate. Unit may have more than one power switch.

 **WARNING**

UNIT OPERATION AND SAFETY HAZARD

Failure to follow this warning could cause personal injury, death and/or equipment damage.

R-410A refrigerant systems operate at higher pressures than standard R-22 systems. Do not use R-22 service equipment or components on R-410A refrigerant equipment.

 **WARNING**

PERSONAL INJURY AND ENVIRONMENTAL HAZARD

Failure to follow this warning could cause personal injury or death.

Relieve pressure and recover all refrigerant before system repair or final unit disposal.

Wear safety glasses and gloves when handling refrigerants. Keep torches and other ignition sources away from refrigerants and oils.

 **CAUTION**

PERSONAL INJURY HAZARD

Failure to follow this caution may result in personal injury.

Sheet metal parts may have sharp edges or burrs. Use care and wear appropriate protective clothing, safety glasses and gloves when handling parts and servicing air conditioning equipment.

 **WARNING**

FIRE HAZARD

Failure to follow this warning could result in severe personal injury and/or property damage.

Inlet pressure tap set screw must be tightened and 1/8-in. NPT pipe plug must be installed to prevent gas leaks.

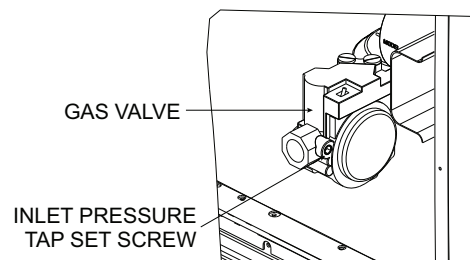

⚠ WARNING

FIRE HAZARD

Failure to follow this warning could result in severe personal injury and/or property damage.

Manifold pressure tap set screw must be tightened and 1/8-in. NPT pipe plug must be installed to prevent gas leaks.

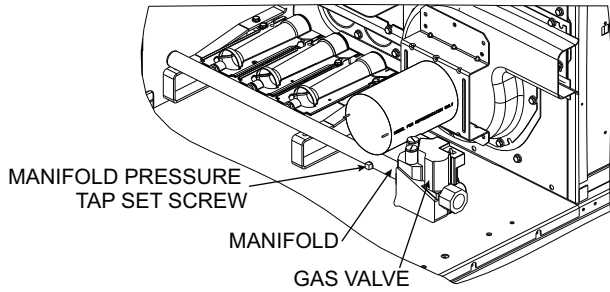

GENERAL

See Fig. 1 for model number nomenclature. See Fig. 2 and 3 for unit dimensional drawings. Figure 4 shows service clearance dimensions.

Rated Indoor Airflow (cfm)

Table 1 lists the rated indoor airflow used for the AHRI efficiency rating for the units covered in this document.

Table 1 — Rated Indoor Airflow (cfm)

MODEL NUMBER	FULL LOAD AIRFLOW (CFM)
48LC**08	2625
48LC**09	2970
48LC**12	3500



Position:	1	2	3	4	5	6	7	8	9	10	11	12	13	14	15	16	17	18
Example:	4	8	L	C	D	0	1	2	A	1	A	5	-	0	A	0	A	0

Unit Heat Type

48 - Gas Heat Packaged Rooftop

Model Series - WeatherExpert®

LC - Ultra High Efficiency

Heat Options

D = Low Gas Heat
 E = Medium Gas Heat
 F = High Gas Heat
 S = Low Heat w/ Stainless Steel Exchanger
 R = Medium Heat w/ Stainless Steel Exchanger
 T = High Heat w/ Stainless Steel Exchanger

Refrig. Systems Options

0 = Three stage cooling capacity control with TXV
 A = Three stage cooling capacity control with TXV and Humidi-MiZer® System

Cooling Tons

08 - 7.5 ton
 09 - 8.5 ton
 12 - 10 ton

Sensor Options

A = None
 B = RA Smoke Detector
 C = SA Smoke Detector
 D = RA + SA Smoke Detector
 E = CO₂
 F = RA Smoke Detector and CO₂
 G = SA Smoke Detector and CO₂
 H = RA + SA Smoke Detector and CO₂

Indoor Fan Options

1 = Standard Static Belt Drive with VFD controller
 2 = Medium Static Belt Drive with VFD controller
 3 = High Static Belt Drive with VFD controller
 4 = Ultra High Static Belt Drive with VFD controller (08, 09 only)

Coil Options: Fin/Tube (Condenser- Evaporator - Hail Guard)

A = Al/Cu - Al/Cu
 B = Precoat Al/Cu - Al/Cu
 C = E-coat Al/Cu - Al/Cu
 D = E-coat Al/Cu - E-coat Al/Cu
 E = Cu/Cu - Al/Cu
 F = Cu/Cu - Cu/Cu
 M = Al/Cu -Al/Cu — Louvered Hail Guard
 N = Precoat Al/Cu - Al/Cu — Louvered Hail Guard
 P = E-coat Al/Cu - Al/Cu — Louvered Hail Guard
 Q = E-coat Al/Cu - E-coat Al/Cu — Louvered Hail Guard
 R = Cu/Cu - Al/Cu — Louvered Hail Guard
 S = Cu/Cu - Cu/Cu — Louvered Hail Guard

Packaging

0 = Standard
 1 = LTL

Electrical Options

A = None
 B = HACR Circuit Breaker
 C = Non-Fused Disconnect
 D = Thru-The-Base Connections
 E = HACR Circuit Breaker and Thru-The Base Connections
 F = Non-Fused Disconnect and Thru-The-Base Connections

Service Options

0 = None
 1 = Unpowered Convenience Outlet
 2 = Powered Convenience Outlet
 3 = Hinged Panels
 4 = Hinged Panels and Unpowered Convenience Outlet
 5 = Hinged Panels and Powered Convenience Outlet

Intake / Exhaust Options

A = None
 B = Standard Leak Temperature Economizer with Barometric Relief
 E = Standard Leak Enthalpy Economizer with Barometric Relief
 N = Ultra Low Leak Temperature Economizer with Barometric Relief
 R = Ultra Low Leak Enthalpy Economizer with Barometric Relief

Base Unit Controls

0 = Electro-mechanical Controls
 1 = RTU Open Multi-Protocol Controller
 4 = SystemVu™ Controller

Design Revision

- = Factory Design Revision

Voltage

1 = 575/3/60
 5 = 208-230/3/60
 6 = 460/3/60

Fig. 1 — 48LC 08-12 Model Number Nomenclature

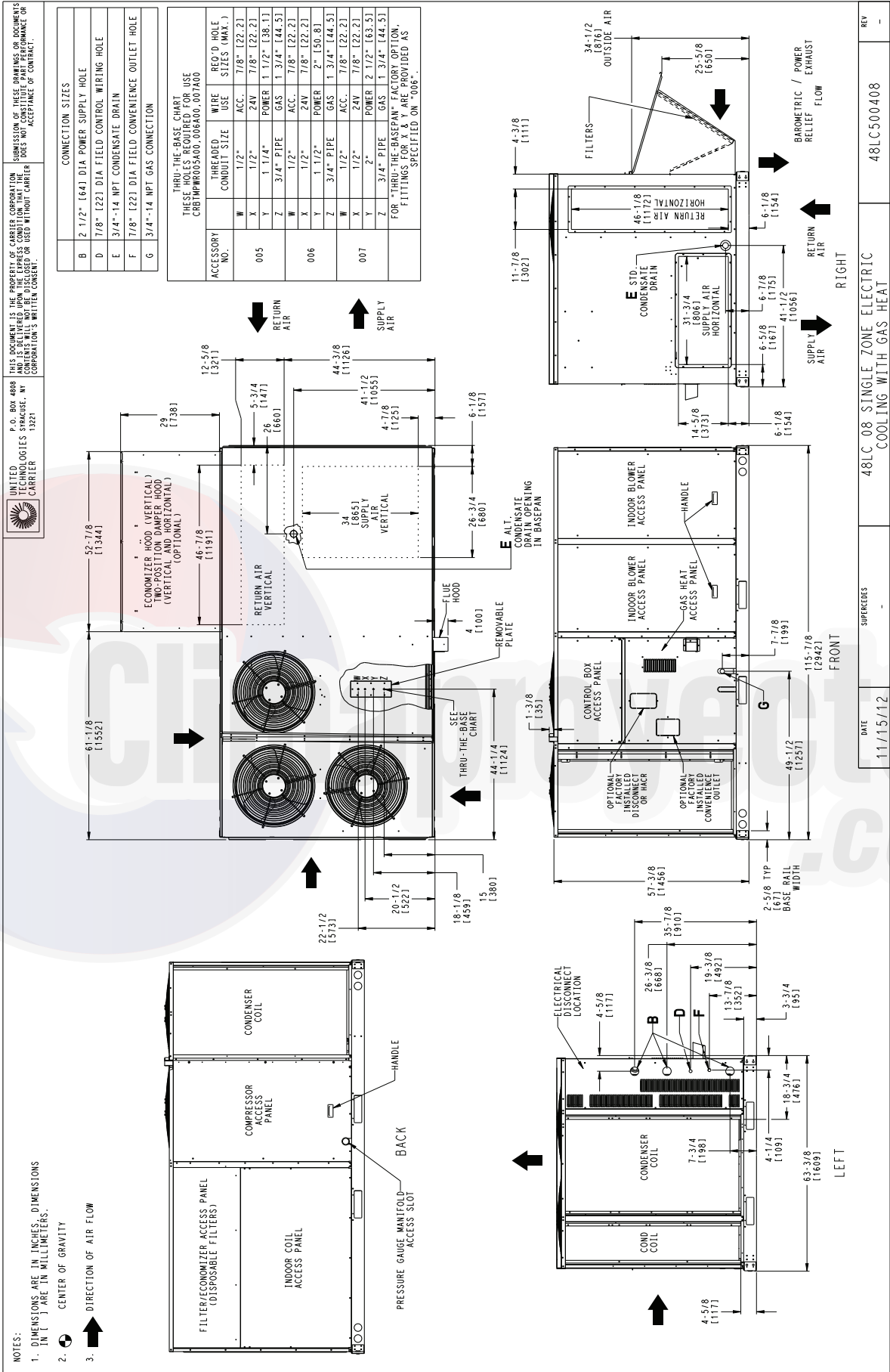

Fig. 2 — Unit Dimensional Drawing - Size 08 Unit

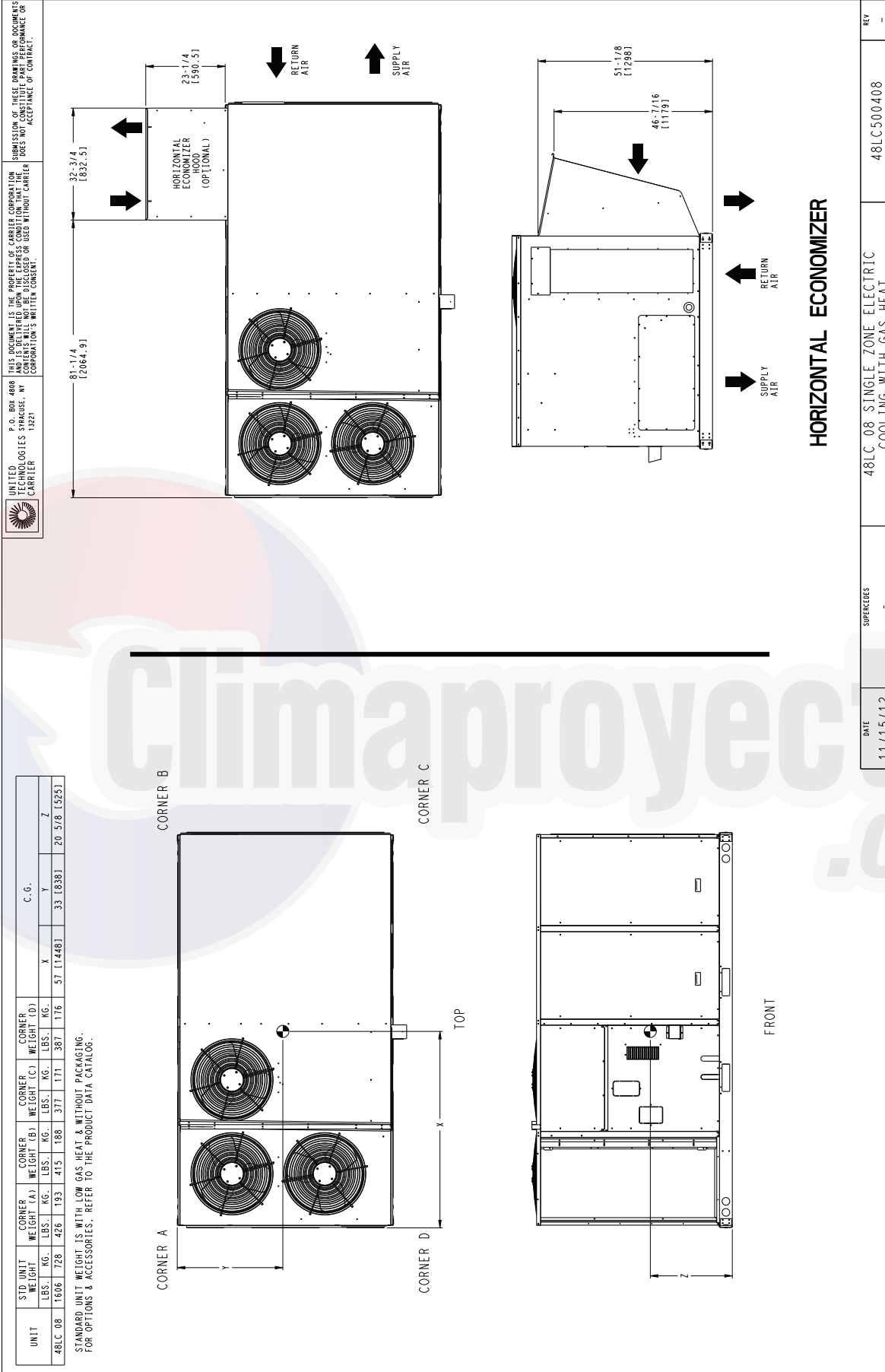

Fig. 2 — Unit Dimensional Drawing - Size 08 Unit (cont)

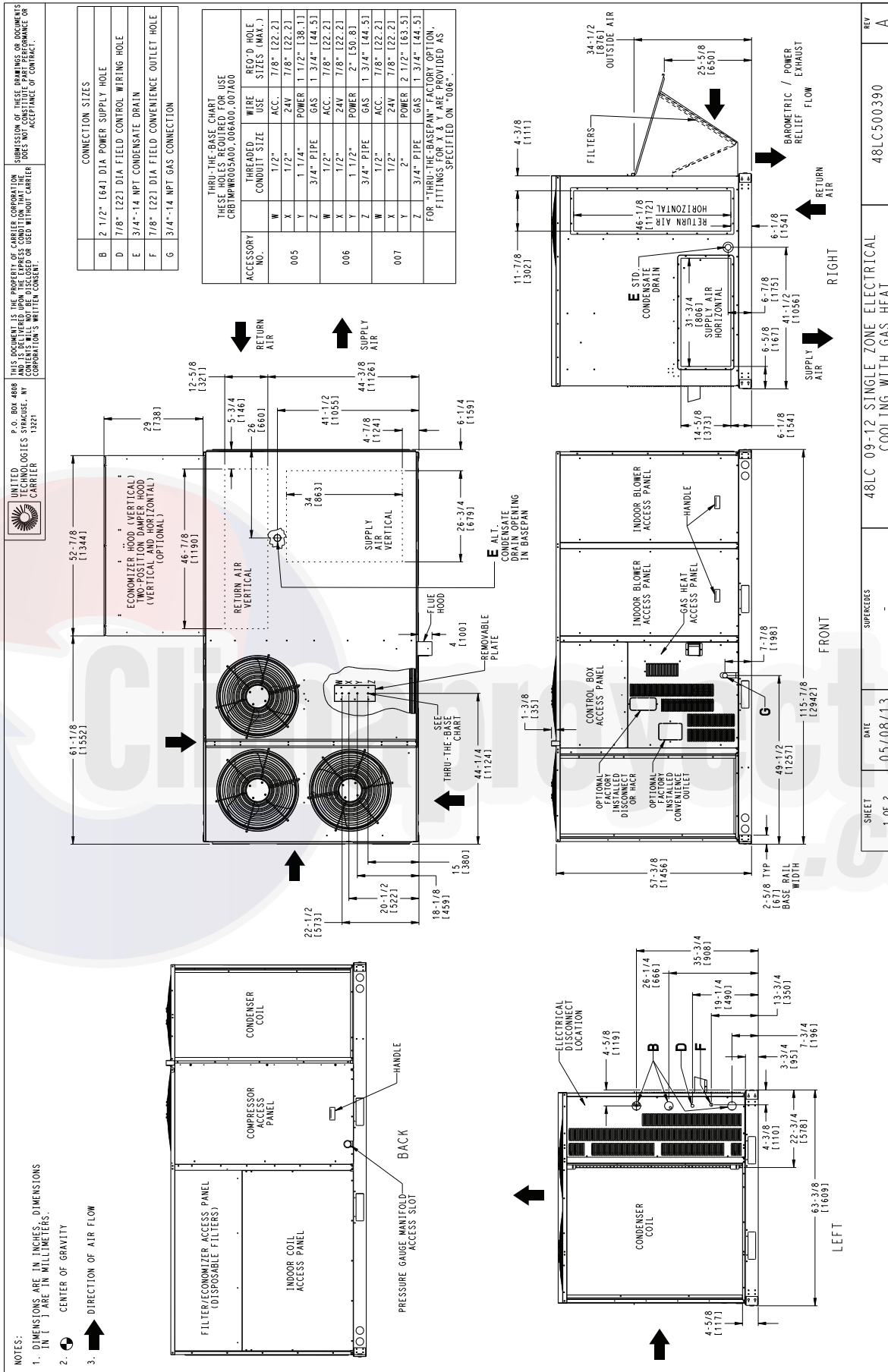

Fig. 3 — Unit Dimensional Drawing - Size 09 and 12 Units

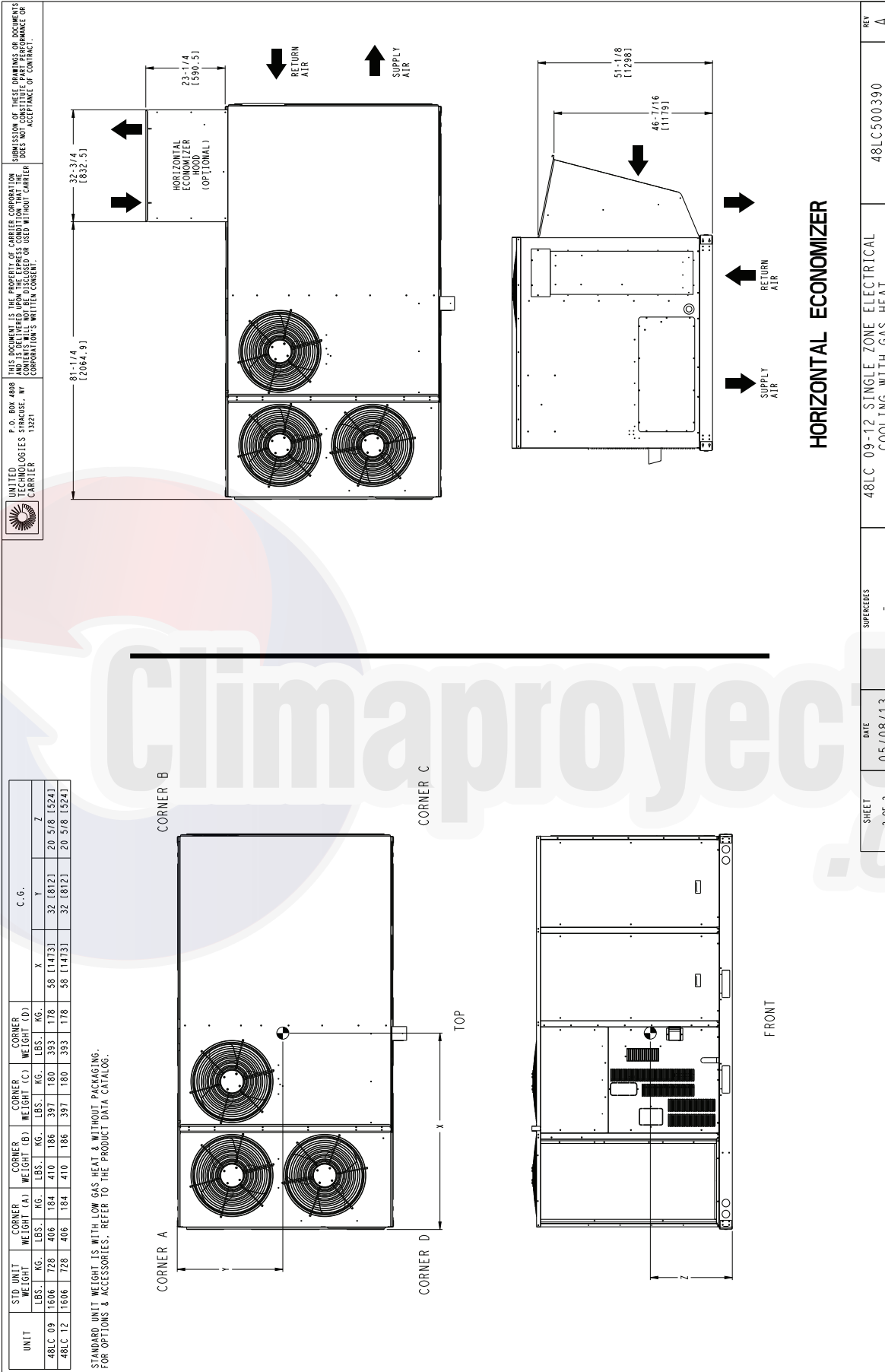
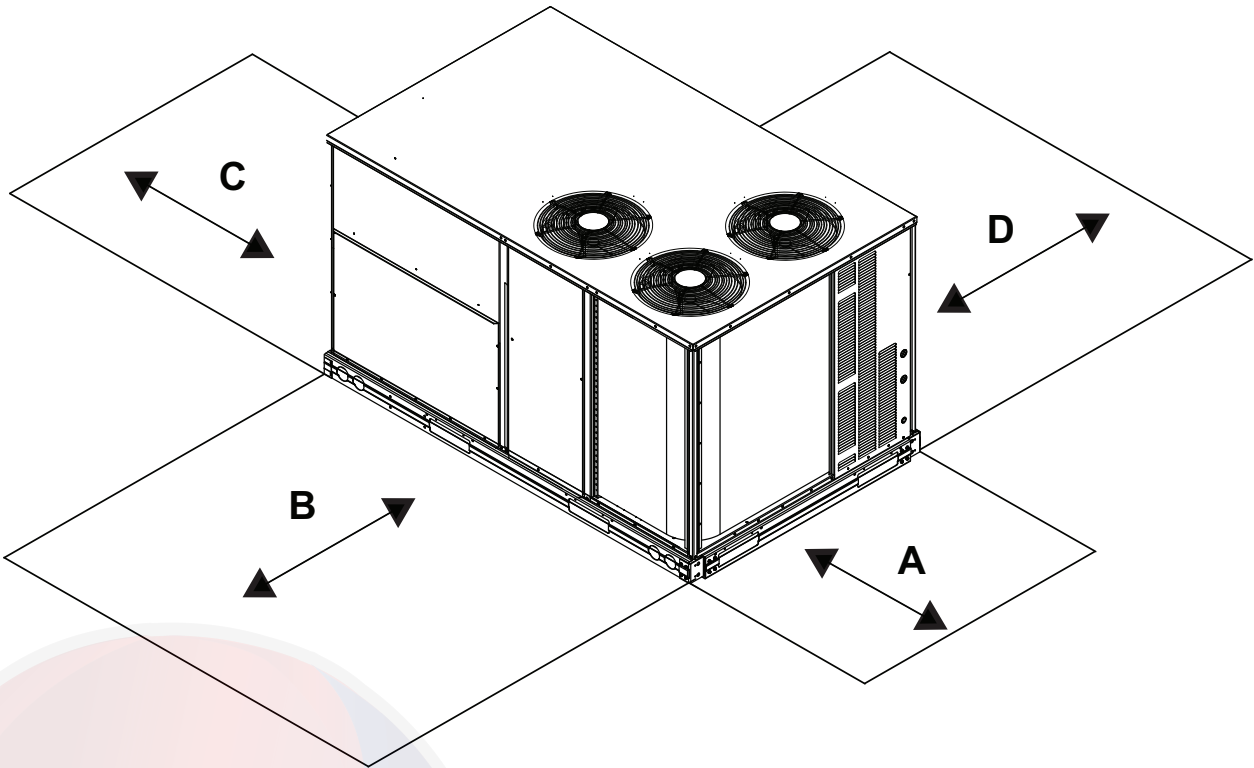

Fig. 3 — Unit Dimensional Drawing - Size 09 and 12 Units (cont)



LOCATION	DIMENSION	CONDITION
A	48-in. (1219 mm)	Unit disconnect is mounted on panel
	18-in. (457 mm)	No disconnect, convenience outlet option
	18-in. (457 mm)	Recommended service clearance
	12-in. (305 mm)	Minimum clearance
B	42-in. (1067 mm)	Surface behind servicer is grounded (e.g., metal, masonry wall)
	36-in. (914 mm)	Surface behind servicer is electrically non-conductive (e.g., wood, fiberglass)
	Special	Check sources of flue products within 10 ft (3 m) of unit fresh air intake hood
C	36-in. (914 mm)	Side condensate drain is used
	18-in. (457 mm)	Minimum clearance
D	48-in. (1219 mm)	No flue discharge accessory installed, surface is combustible material
	42-in. (1067 mm)	Surface behind servicer is grounded (e.g., metal, masonry wall, another unit)
	36-in. (914 mm)	Surface behind servicer is electrically non-conductive (e.g., wood, fiberglass)
	Special	Check for adjacent units or building fresh air intakes within 10 ft (3 m) of this unit's flue outlet

NOTE: Unit not designed to have overhead obstruction. Contact Application Engineering for guidance on any application planning overhead obstruction or for vertical clearances.

Fig. 4 — Service Clearance Dimensional Drawing

INSTALLATION

Jobsite Survey

Complete the following checks before installation.

1. Consult local building codes and the NEC (National Electrical Code) ANSI/NFPA 70 for special installation requirements.
2. Determine unit location (from project plans) or select unit location.
3. Check for possible overhead obstructions which may interfere with unit lifting or rigging.

Step 1 — Plan for Unit Location

Select a location for the unit and its support system (curb or other) that provides for at least the minimum clearances required for safety. This includes the clearance to combustible surfaces, unit performance and service access below, around and above unit as specified in unit drawings. See Fig. 4.

NOTE: Consider also the effect of adjacent units.

Unit may be installed directly on wood flooring or on Class A, B, or C roof-covering material when roof curb is used.

Do not install unit in an indoor location. Do not locate air inlets near exhaust vents, relief valves, or other sources of contaminated air.

Although unit is weatherproof, avoid locations that permit water from higher level runoff and overhangs to fall onto the unit.

Select a unit mounting system that provides adequate height to allow installation of condensate trap per requirements. Refer to “Install External Condensate Trap and Line” on page 18 for required trap dimensions.

ROOF MOUNT

Check building codes for weight distribution requirements. Unit operating weight is shown in Table 2.

Table 2 — Operating Weights

48LC**	UNITS LB (KG)		
	08	09	12
Base Unit	1430 (650)	1534 (696)	1554 (705)
Economizer			
Horizontal	103 (47)	103 (47)	103 (47)
Vertical	242 (110)	242 (110)	242 (110)
Powered Outlet	35 (16)	35 (16)	35 (16)
Curb			
14-in. (356 mm)	180 (82)	180 (82)	180 (82)
24-in. (610 mm)	255 (116)	255 (116)	255 (116)

Step 2 — Plan for Sequence of Unit Installation

The support method used for this unit will dictate different sequences for the steps of unit installation. For example, on curb-mounted units, some accessories must be installed on the unit before the unit is placed on the curb. Review the following for recommended sequences for installation steps.

CURB-MOUNTED INSTALLATION

1. Install curb
2. Install field-fabricated ductwork inside curb
3. Install accessory thru-base service connection package (affects curb and unit) (refer to accessory installation instructions for details)
4. Prepare bottom condensate drain connection to suit planned condensate line routing (refer to “Install External Condensate Trap and Line” on page 18 for details)
5. Rig and place unit
6. Install outdoor air hood
7. Install condensate line trap and piping
8. Make electrical connections
9. Install other accessories

PAD-MOUNTED INSTALLATION

1. Prepare pad and unit supports
2. Check and tighten the bottom condensate drain connection plug
3. Rig and place unit
4. Convert unit to side duct connection arrangement
5. Install field-fabricated ductwork at unit duct openings
6. Install outdoor air hood
7. Install condensate line trap and piping
8. Make electrical connections
9. Install other accessories

FRAME-MOUNTED INSTALLATION

Frame-mounted applications generally follow the sequence for a curb installation. Adapt as required to suit specific installation plan.

Step 3 — Inspect Unit

Inspect unit for transportation damage. File any claim with transportation agency.

Confirm before installation of unit that voltage, amperage and circuit protection requirements listed on unit data plate agree with power supply provided.

On units with hinged panel option, check to be sure all latches are snug and in closed position.

Locate the carton containing the outside air hood parts (see Fig. 14). Do not remove carton until unit has been rigged and located in final position.

Step 4 — Provide Unit Support

ROOF CURB MOUNT

Accessory roof curb details and dimensions are shown in Fig. 6. Assemble and install accessory roof curb in accordance with instructions shipped with the curb.

NOTE: The gasketing of the unit to the roof curb is critical for a watertight seal. Install gasket supplied with the roof curb as shown in Fig. 6. Improperly applied gasket can also result in air leaks and poor unit performance.

Curb should be level. This is necessary for unit drain to function properly. Unit leveling tolerances are shown in Fig. 5. Refer to Accessory Roof Curb Installation Instructions for additional information as required.

Install insulation, cant strips, roofing felt, and counter flashing as shown. Ductwork must be attached to curb and not to the unit.

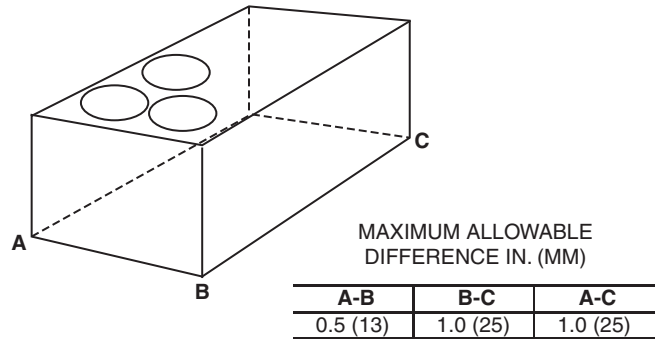

Fig. 5 — Unit Leveling Tolerances

IMPORTANT: If the unit’s gas connection and/or electric and control wiring is to be routed through the basepan and the unit is equipped with the factory-installed thru-the-base service option, see the following sections:

- Factory-Option Thru-Base Connections (Gas Connection) on page 16
- Factory-Option Thru-Base Connections (Electrical Connections) on page 29

If using the field-installed Thru-the-Base accessory, follow the instructions provided with the accessory kit.

NOTE: If gas and/or electrical connections are not going to occur at this time, tape or otherwise cover the fittings so that moisture does not get into the building or conduit in the interim.

SLAB MOUNT (HORIZONTAL UNITS ONLY)

Provide a level concrete slab that extends a minimum of 6-in. (150 mm) beyond unit cabinet. Install a gravel apron in front of condenser coil air inlet to prevent grass and foliage from obstructing airflow.

NOTE: Horizontal units may be installed on a roof curb if required.

ALTERNATE UNIT SUPPORT (IN LIEU OF CURB OR SLAB MOUNT)

A non-combustible sleeper rail can be used in the unit curb support area. If sleeper rails cannot be used, support the long sides of the unit with a minimum of 3 equally spaced 4-in. x 4-in. (102 mm x 102 mm) pads on each side.

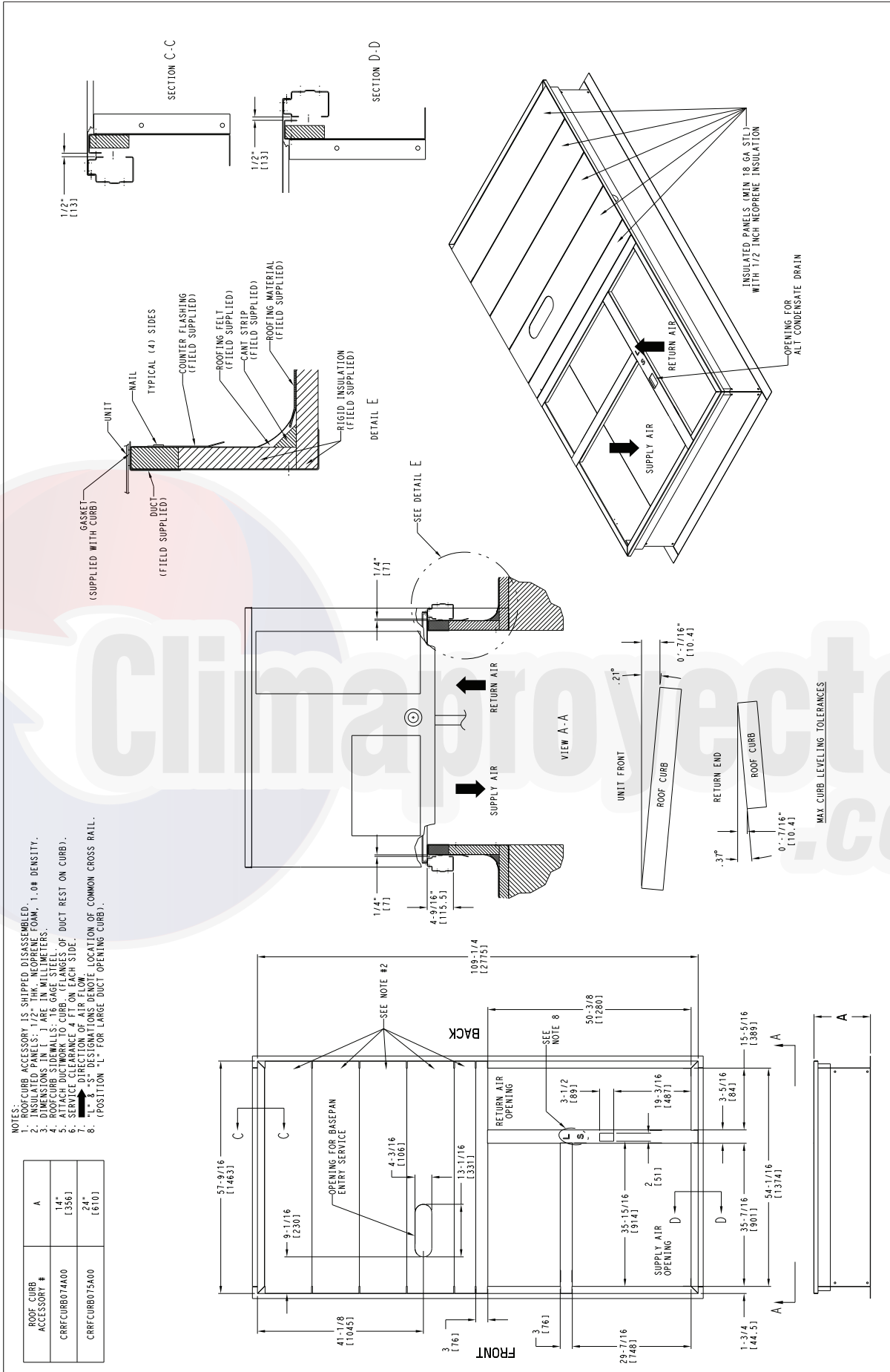

Fig. 6 — Roof Curb Details - Size 08-12 Units

Step 5 — Field Fabricate Ductwork

NOTE: Cabinet return-air static pressure (a negative condition) shall not exceed 0.35 in. wg (87 Pa) with economizer or 0.45 in. wg (112 Pa) without economizer.

For vertical ducted applications, secure all ducts to roof curb and building structure. Do not connect ductwork to unit.

Fabricate supply ductwork so that the cross sectional dimensions are equal to or greater than the unit supply duct opening dimensions for the first 18-in. (458 mm) of duct length from the unit basepan.

Insulate and weatherproof all external ductwork, joints, and roof openings with counter flashing and mastic in accordance with applicable codes.

Ducts passing through unconditioned spaces must be insulated and covered with a vapor barrier.

If a plenum return is used on a vertical unit, the return should be ducted through the roof deck to comply with applicable fire codes.

⚠ CAUTION

PROPERTY DAMAGE HAZARD

Failure to follow this caution may result in damage to roofing materials.

Membrane roofs can be cut by sharp sheet metal edges. Be careful when placing any sheet metal parts on such roof.

Step 6 — Rig and Place Unit

When the unit is ready to be rigged and no longer will be lifted by a fork truck, the wood protector under the basepan must be removed. Remove 4 screws from each base rail. Wood protector will drop to the ground. See instructions on the unit base rails.

Keep unit upright and do not drop. Spreader bars are not required. Rollers may be used to move unit across a roof. Level by using unit frame as a reference. See Table 2 and Fig. 7 for additional information.

Lifting holes are provided in base rails as shown in Fig. 7. Refer to rigging instructions on unit.

Rigging materials under unit (cardboard or wood) must be removed PRIOR to placing the unit on the roof curb.

When using the standard side drain connection, ensure the red plug in the alternate bottom connection is tight. Do this before setting the unit in place. The red plug can be tightened with a 1/2-in. square socket drive extension. For further details, see “Install External Condensate Trap and Line” on page 18.

Before setting the unit onto the curb, recheck gasketing on curb.

⚠ CAUTION

UNIT DAMAGE HAZARD

Failure to follow this caution may result in equipment damage.

All panels must be in place when rigging. Unit is not designed for handling by fork truck when packaging is removed.

If using top crate as spreader bar, once unit is set, carefully lower wooden crate off building roof top to ground. Ensure that no people or obstructions are below prior to lowering the crate.

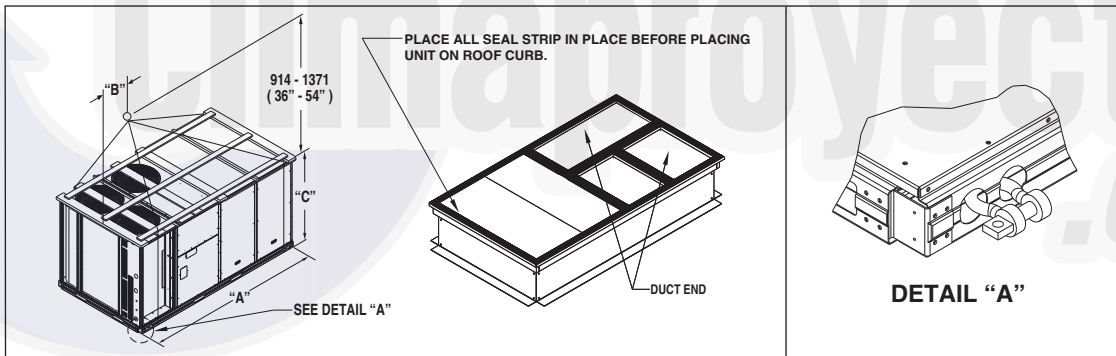

UNIT	MAX WEIGHT		DIMENSIONS					
			A		B		C	
	LB	KG	IN	MM	IN	MM	IN	MM
48LC*008	2460	1116	116	2945	57	1448	59.5	1510
48LC*009	2465	1118	116	2945	58	1473	59.5	1510
48LC*012	2465	1118	116	2945	58	1473	59.5	1510

- NOTES:
- Dimensions in () are in millimeters.
 - Hook rigging shackles through holes in base rail, as shown in detail “A.” Holes in base rails are centered around the unit center of gravity.
 - Use wooden top to prevent rigging straps from damaging unit.

Fig. 7 — Rigging Details

POSITIONING ON CURB

For full perimeter curbs CRRFCURB074A00 and 075A00, the clearance between the roof curb and the front and rear base rails should be $\frac{1}{4}$ -in. (6.4 mm). The clearance between the curb and the end base rails should be $\frac{1}{2}$ -in. (13 mm). For retrofit applications with curbs CRRFCURB003A01 and 4A01, the unit should be positioned as shown in Fig. 8. Maintain the $15\frac{1}{2}$ -in. (394 mm) and $8\frac{5}{8}$ -in. (220 mm) clearances and allow the $22\frac{5}{16}$ -in. (567 mm) dimension to float if necessary.

If the alternative condensate drain location through the bottom of the unit is used in conjunction with a retrofit curb, the hole in the curb must be moved $12\frac{1}{2}$ -in. (320 mm) towards the end of the unit. (See Fig. 9.)

Although unit is weatherproof, guard against water from higher level runoff and overhangs.

Remove all shipping materials and top skid. Remove extra center post from the condenser end of the unit so that the condenser end of the unit matches Fig. 29 and 30. Recycle or dispose of all shipping materials.

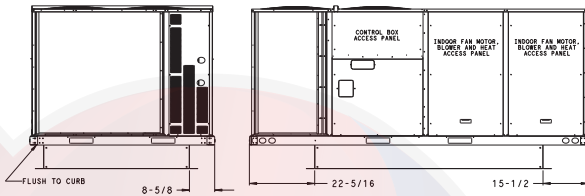

Fig. 8 — Retrofit Installation Dimensions

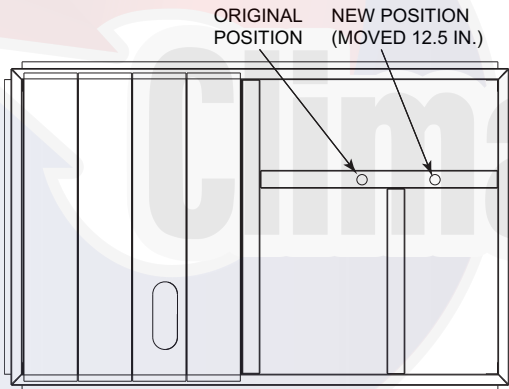

Fig. 9 — Alternative Condensate Drain Hole Positions

IMPORTANT: If the unit has the factory-installed thru-the-base option, make sure to complete installation of the option before placing the unit on the roof curb.

See the following sections:

- Factory-Option Thru-Base Connections (Gas Connection) on page 16
- Factory-Option Thru-Base Connections (Electrical Connections) on page 29

NOTE: If gas and/or electrical connections are not going to occur at this time, tape or otherwise cover the fittings so that moisture does not get into the building or conduit in the interim.

Step 7 — Convert to Horizontal and Connect Ductwork (when required)

Unit is shipped in the vertical duct configuration. Unit without factory-installed economizer or return-air smoke detector option may be field-converted to horizontal ducted configuration using accessory CRDUCTCV002A00. To convert to horizontal configuration, remove screws from side duct opening covers (see Fig. 10) and remove covers. Discard the supply duct cover. Install accessory CRDUCTCV002A00 to cover the vertical supply duct opening. Use the return duct cover removed from the unit end panel to cover the vertical return duct opening. Use the screws to install the covers on vertical duct openings with the insulation-side down. The panels must be inserted into the notches on the basepan to properly seal. The notches are covered by the tape used to secure the insulation to the basepan and are not easily seen. See Fig. 11 for position of the notches in the basepan. Seals around duct openings must be tight. Secure with screws as shown in Fig. 12. Cover seams with foil duct tape.

Field-supplied flanges should be attached to horizontal duct openings and all ductwork should be secured to the flanges. Insulate and weatherproof all external ductwork, joints, and roof or building openings with counter flashing and mastic in accordance with applicable codes.

Do not cover or obscure visibility to the unit's informative data plate when insulating horizontal ductwork.

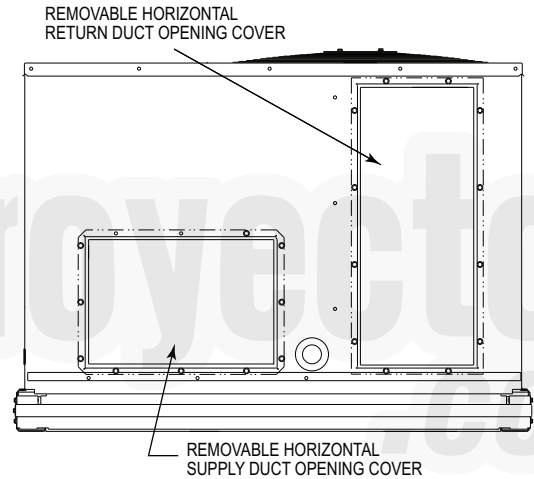

Fig. 10 — Horizontal Conversion Panels

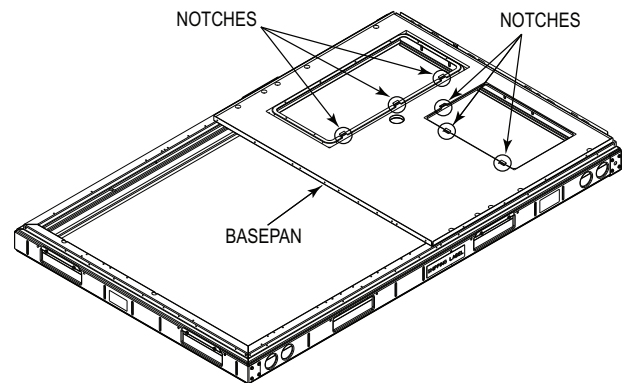

Fig. 11 — Location of Notches

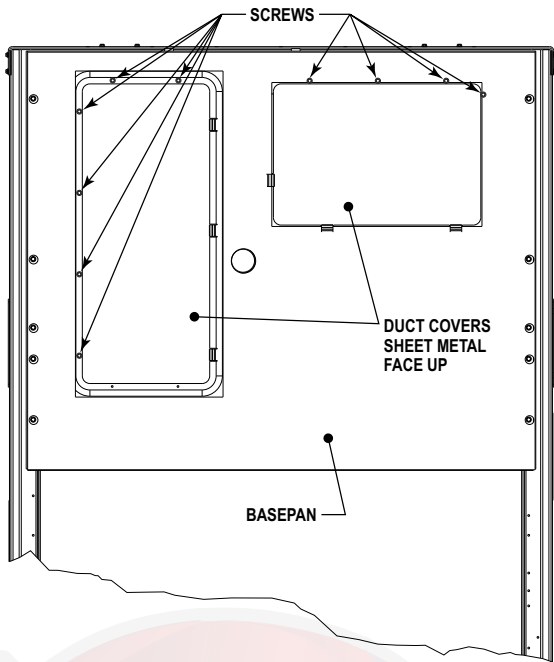

Fig. 12 — Horizontal Duct Panels In Place

Step 8 — Install Outside Air Hood

ECONOMIZER HOOD REMOVAL AND SETUP – FACTORY OPTION

1. The hood is shipped in knock-down form and located in the return air compartment. It is attached to the economizer using two plastic tie-wraps.
2. To gain access to the hood, remove the filter access panel. (See Fig. 13.)
3. Locate and cut the (2) plastic tie-wraps, being careful not to damage any wiring. (See Fig. 14.)
4. Carefully lift the hood assembly through the filter access opening and assemble per the steps outlined in the following procedure *Economizer Hood Assembly*.

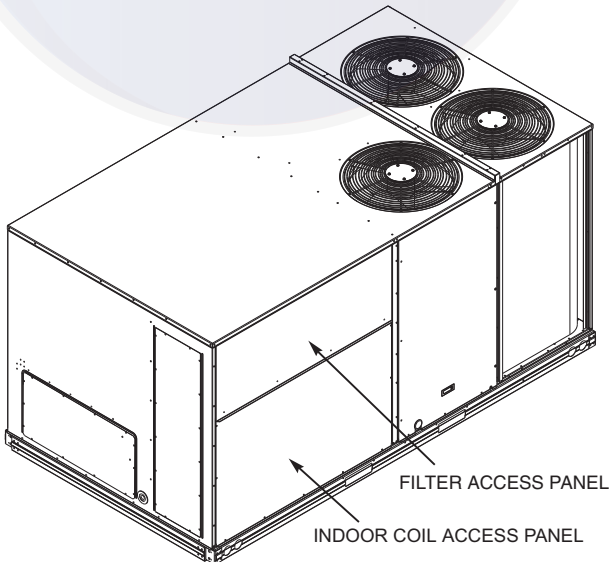

Fig. 13 — Typical Access Panel Location

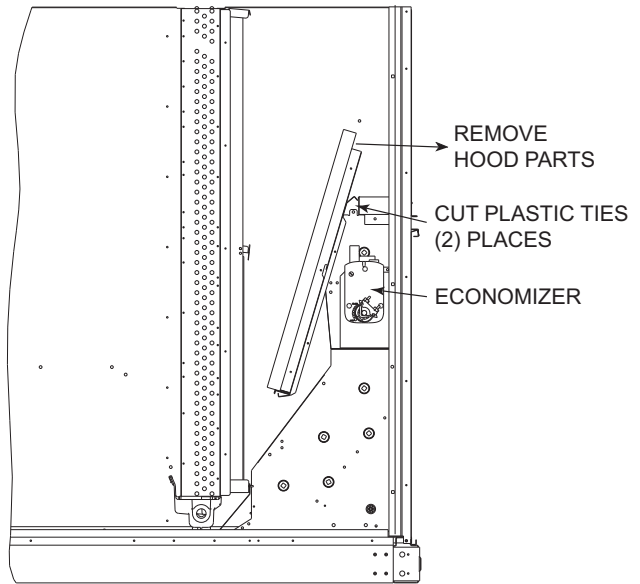

Fig. 14 — Economizer Hood Package Location

ECONOMIZER HOOD ASSEMBLY

NOTE: If the power exhaust accessory is to be installed on the unit, the hood shipped with the unit will not be used and must be discarded. Save the aluminum filter for use in the power exhaust hood assembly.

1. The indoor coil access panel will be used as the top of the hood. If the panel is still attached to the unit, remove the screws along the sides and bottom of the panel. See Fig. 15.

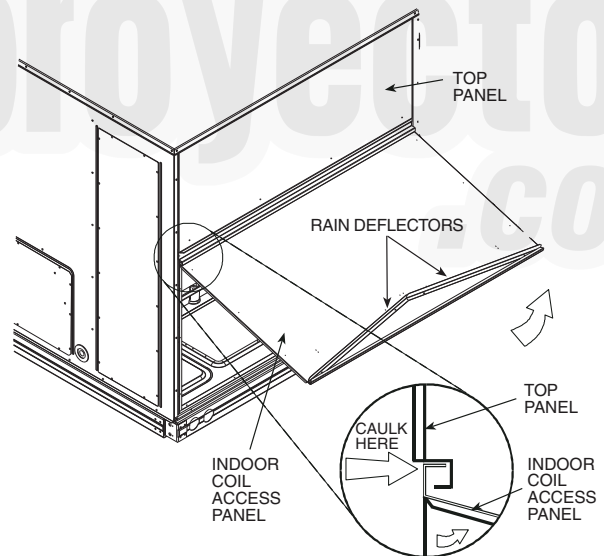

Fig. 15 — Indoor Coil Access Panel Relocation

2. Swing out indoor coil access panel and insert the hood sides under the panel (hood top). *Be careful not to lift the panel too far as it might fall out.* Use the screws provided to attach the hood sides to the hood top. Use screws provided to attach the hood sides to the unit. See Fig. 16.

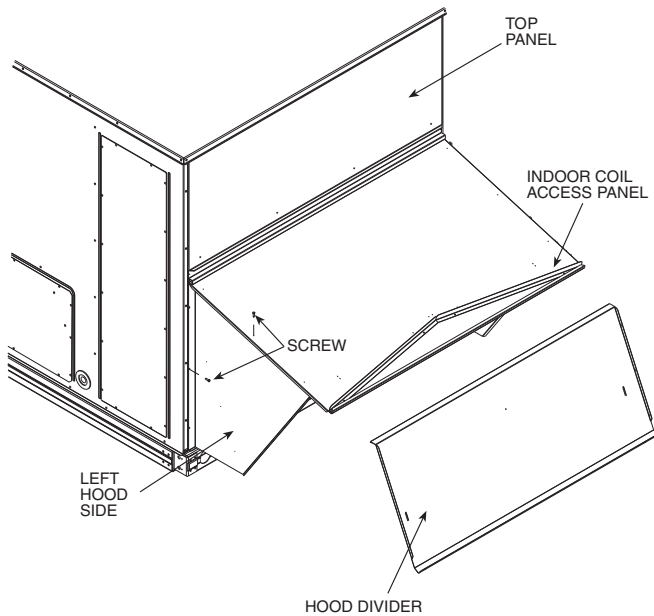

Fig. 16 — Economizer Hood Construction

3. Remove the shipping tape holding the economizer barometric relief damper in place.
4. Insert the hood divider between the hood sides. See Fig. 16 and 17. Secure hood divider with 3 screws on each hood side. The hood divider is also used as the bottom filter rack for the aluminum filter.
5. Attach the post that separates the filters with the screws provided.
6. Open the filter clips which are located underneath the hood top. Insert the aluminum filters into the bottom filter rack (hood divider). Push the filter into position past the open filter clips. Close the filter clips to lock the filters into place. See Fig. 17.
7. Install the two rain deflectors on the edge of the hood top as shown in Fig. 15.

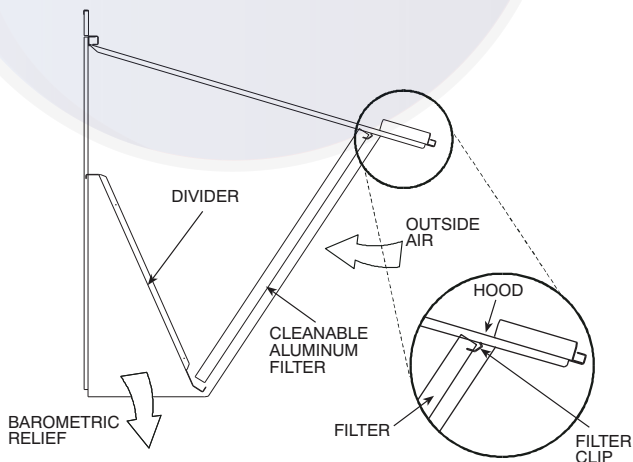

Fig. 17 — Economizer Filter Installation

8. Caulk the ends of the joint between the unit top panel and the hood top as shown in Fig. 15.
9. Replace the filter access panel.

Step 9 — Install Flue Hood

The flue hood is shipped screwed to the basepan beside the burner compartment access panel. Remove the panel below the control box access panel to access the flue hood shipping location. Using screws provided, install flue hood and screen in location shown in Fig. 18.

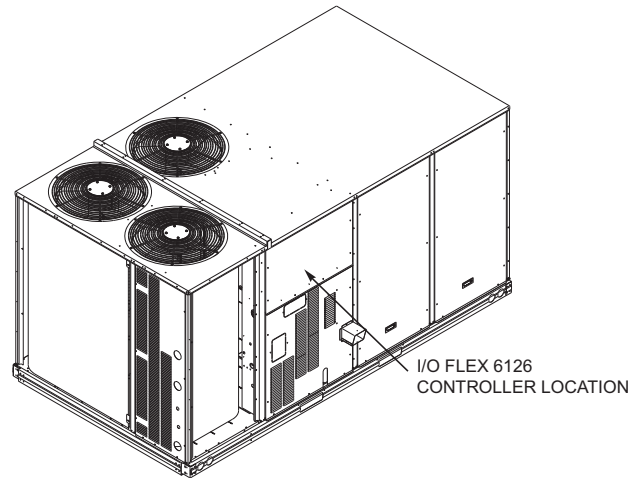

Fig. 18 — Flue Hood Details

Step 10 — Install Gas Piping

Installation of the gas piping must be accordance with local building codes and with applicable national codes. In U.S.A., refer to NFPA 54/ANSI Z223.1 National Fuel Gas Code (NFGC). In Canada, installation must be accordance with the CAN/CSA B149.1 and CAN/CSA B149.2 installation codes for gas burning appliances.

This unit is factory equipped for use with natural gas fuel at elevations up to 2000 ft (610 m) above sea level. Unit may be field converted for operation at elevations above 2000 ft (610 m) and/or for use with liquefied petroleum fuel. See accessory kit installation instructions regarding these accessories.

NOTE: In U.S.A. the input rating for altitudes above 2000 ft (610 m) must be derated by 4% for each 1000 ft (305 m) above sea level.

For natural gas applications, gas pressure at unit gas connection must not be less than 4 in. wg (996 Pa) or greater than 13 in. wg (3240 Pa) while the unit is operating (see Table 3). For liquefied petroleum applications, the gas pressure must not be less than 11 in. wg (2740 Pa) or greater than 13 in. wg (3240 Pa) at the unit connection (see Table 4).

The gas supply pipe enters the unit at the burner access panel on the front side of the unit, through the long slot at the bottom of the access panel. The gas connection to the unit is made to the $\frac{3}{4}$ -in. FPT gas inlet port on the unit gas valve.

Table 3 — Natural Gas Supply Line Pressure Ranges

UNIT	MIN	MAX
48LC*008/09/12	4.0 in. wg (996 Pa)	13.0 in. wg (3240 Pa)

Table 4 — Liquid Propane Supply Line Pressure Ranges

UNIT	MIN	MAX
48LC*008/09/12	11.0 in. wg (2740 Pa)	13.0 in. wg (3240 Pa)

Manifold pressure is factory-adjusted for natural gas (NG) fuel use. Adjust as required to obtain best flame characteristics. See Table 5.

Manifold pressure for liquid propane (LP) fuel must be adjusted to specified range. Follow instructions in the accessory kit to make initial readjustment. See Table 6.

Table 5 — Natural Gas Manifold Pressure Ranges

UNIT MODEL	UNIT SIZE	HIGH FIRE	LOW FIRE
48LCD/E/S/R/O	08, 09, 12	3.5 in. wg (872 Pa)	2.0 in. wg (498 Pa)
48LCF/T0 (High Heat units only)	12 only	3.4 in. wg (847 Pa)	2.3 in. wg (573 Pa)

Table 6 — Liquid Propane Manifold Pressure Ranges

UNIT MODEL	UNIT SIZE	HIGH FIRE	LOW FIRE
48LCD/E/S/R/O	08, 09, 12	10.0 in. wg (2491 Pa)	5.7 in. wg (1420 Pa)
48LCF/T0 (High Heat units only)	12 only	6.2 in. wg (1554 Pa)	3.9 in. wg (971 Pa)

CAUTION

EQUIPMENT DAMAGE

Failure to follow this caution may result in equipment damage. When connecting the gas line to the unit gas valve, the installer **MUST** use a backup wrench to prevent damage to the valve.

Install a gas supply line that runs to the unit heating section. Refer to the NFPA 54/NFGC or equivalent code for gas pipe sizing data. Size the gas supply line to allow for a maximum pressure drop of 0.5 in. wg (124 Pa) between gas regulator source and unit gas valve connection when unit is operating at high-fire flow rate.

The gas supply line can approach the unit in three ways: horizontally from outside the unit (across the roof), thru-curb/under unit basepan (accessory kit required) or through unit basepan (factory-option or accessory kit required). Consult accessory kit installation instructions for details on these installation methods. Observe clearance to gas line components per Fig. 19.

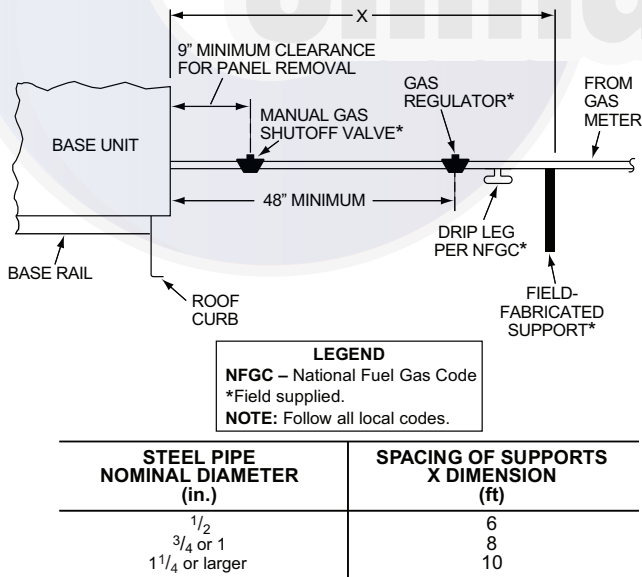

Fig. 19 — Gas Piping Guide

FACTORY-OPTION THRU-BASE CONNECTIONS (GAS CONNECTION)

This service connection kit consists of a 3/4-in. NPT gas adapter fitting (stainless steel), a 1/2-in. electrical bulkhead connector and a 1 1/2-in. electrical bulkhead connector, connected to an “L” bracket covering the embossed (raised) section of the unit basepan in the condenser section. See Fig. 20.

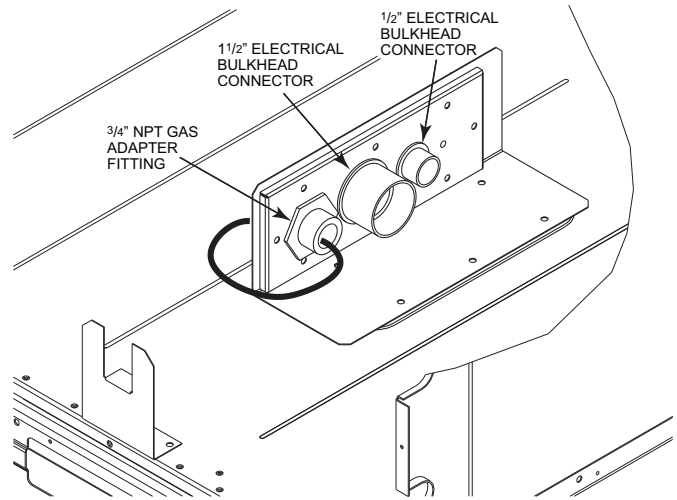

Fig. 20 — Thru-the-Base Option, Shipping Position

1. Remove the “L” bracket assembly from the unit (see Fig. 20).
2. Cut and discard the wire tie on the gas fitting. Hand tighten the fitting if it has loosened in transit.
3. Remove connector plate assembly from the “L” bracket and discard the “L” bracket, but retain the washer head screws and the gasket (located between the “L” bracket and the connector plate assembly).

NOTE: Take care not to damage the gasket, as it is reused in the following step.

4. Place the gasket over the embossed area in the basepan, aligning the holes in the gasket to the holes in the basepan. See Fig. 21.
5. Install the connector plate assembly to the basepan using 8 of the washer head screws.

NOTE: If gas and/or electrical connections are not going to occur at this time, tape or otherwise cover the fittings so that moisture does not get into the building or conduit in the interim.

The thru-base gas connector has male and female threads. The male threads protrude above the basepan of the unit; the female threads protrude below the basepan.

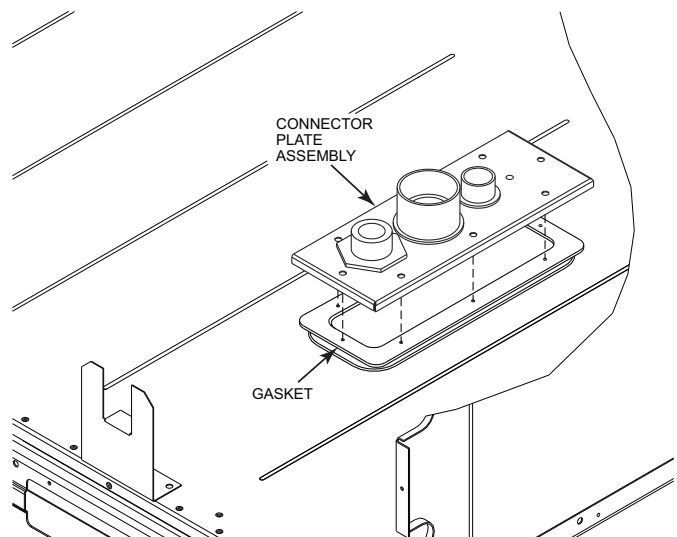

Fig. 21 — Completing Installation of Thru-the-Base Option

Check tightness of connector lock nuts before connecting gas piping.

Install a 3/4-in. NPT street elbow on the thru-base gas fitting. Attach a 3/4-in. pipe nipple with minimum length of 16-in. (406 mm) (field-supplied) to the street elbow and extend it through the access panel at the gas support bracket. (See Fig. 22.)

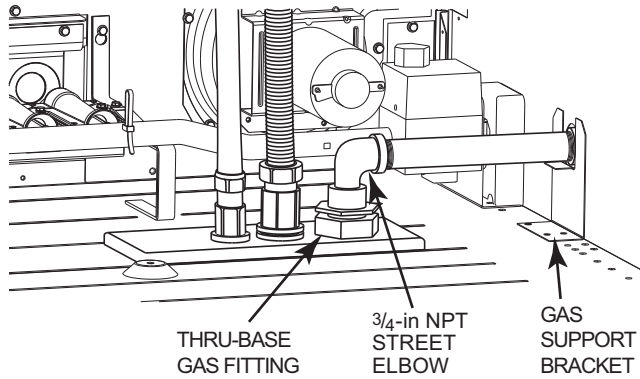

Fig. 22 — Gas Line Piping

Other hardware required to complete the installation of the gas supply line will include a manual shutoff valve, a sediment trap (drip leg) and a ground-joint union. A pressure regulator valve may also be required (to convert gas pressure from pounds to inches of pressure). The manual shutoff valve must be located within 6 ft (1.83 m) of the unit. The union, located in the final leg entering the unit, must be located at least 9-in. (230 mm) away from the access panel to permit the panel to be removed for service. If a regulator valve is installed, it must be located a minimum of 4 ft (1220 mm) away from the unit's flue outlet. Some municipal codes require that the manual shutoff valve be located upstream of the sediment trap. See Fig. 23 and 24 for typical piping arrangements for gas piping that has been routed through the side-wall of the curb. See Fig. 25 for typical piping arrangement when thru-base is used. Ensure that all piping does not block access to the unit's main control box or limit the required working space in front of the control box.

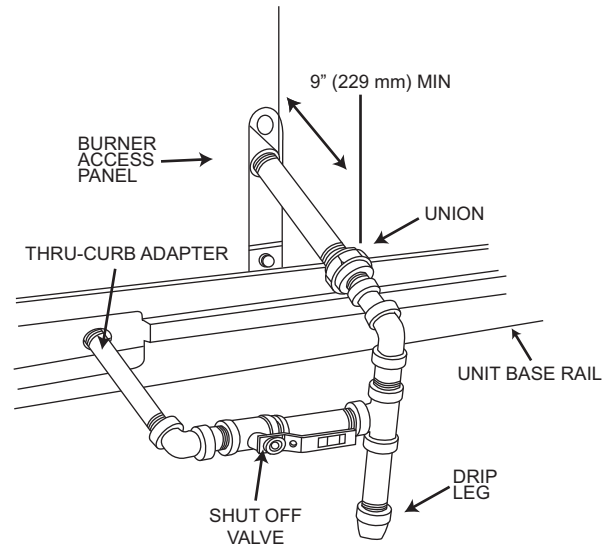

Fig. 24 — Gas Piping with Offset Drip Leg

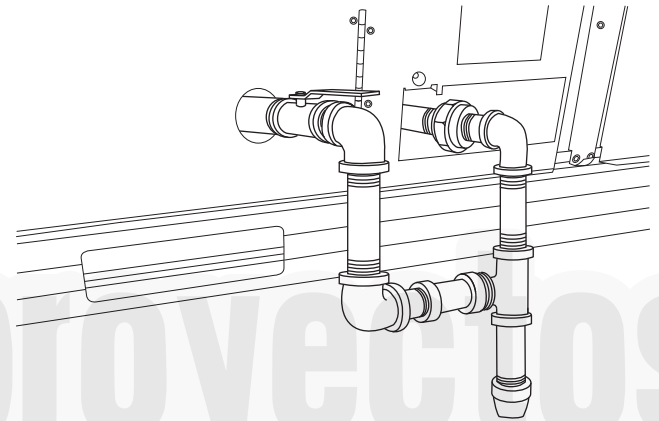

Fig. 25 — Gas Piping Thru-Base Connections

When installing the gas supply line, observe local codes pertaining to gas pipe installations. Refer to the NFPA 54/ANSI Z223.1 NFGC latest edition (in Canada, CAN/CSA B149.1). In the absence of local building codes, adhere to the following pertinent recommendations:

1. Avoid low spots in long runs of pipe. Grade all pipe 1/4-in. in every 15 ft (7 mm in every 5 m) to prevent traps. Grade all horizontal runs downward to risers. Use risers to connect to heating section and to meter.
2. Protect all segments of piping system against physical and thermal damage. Support all piping with appropriate straps, hangers, etc. Use a minimum of one hanger every 6 ft (1.8 m). For pipe sizes larger than 1/2-in., follow recommendations of national codes.
3. Apply joint compound (pipe dope) sparingly and only to male threads of joint when making pipe connections. Use only pipe dope that is resistant to action of liquefied petroleum gases as specified by local and/or national codes. If using PTFE (Teflon¹) tape, ensure the material is Double Density type and is labeled for use on gas lines. Apply tape per manufacturer's instructions.
4. Pressure-test all gas piping in accordance with local and national plumbing and gas codes before connecting piping to unit.

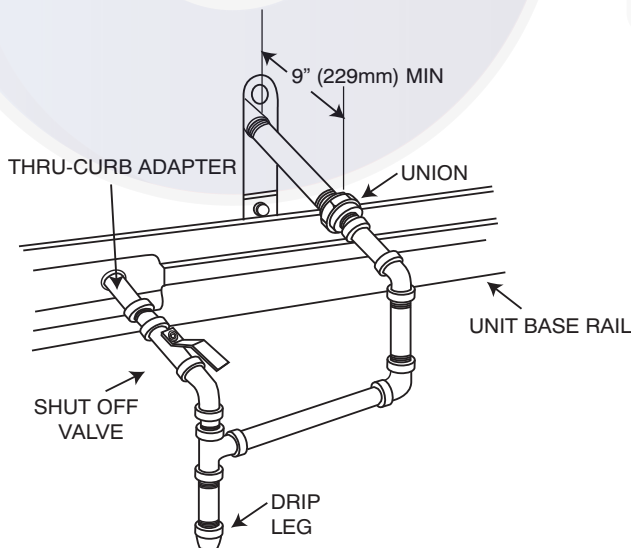

Fig. 23 — Gas Piping with Direct Drip Leg

1. Teflon is a registered trademark of DuPont.

NOTE: Pressure test the gas supply system after the gas supply piping is connected to the gas valve. The supply piping must be disconnected from the gas valve during the testing of the piping systems when test pressure is in excess of 0.5 psig (3450 Pa). Pressure test the gas supply piping system at pressures equal to or less than 0.5 psig (3450 Pa). The unit heating section must be isolated from the gas piping system by closing the external main manual shutoff valve and slightly opening the ground-joint union.

Check for gas leaks at the field-installed and factory-installed gas lines after all piping connections have been completed. Use soap-and-water solution (or method specified by local codes and/or regulations).

⚠ WARNING

Failure to follow this warning could result in personal injury, death and/or property damage.

- Connect gas pipe to unit using a backup wrench to avoid damaging gas controls.
- Never purge a gas line into a combustion chamber.
- Never test for gas leaks with an open flame. Use a commercially available soap solution made specifically for the detection of leaks to check all connections.
- Use proper length of pipe to avoid stress on gas control manifold.

NOTE: If orifice hole appears damaged or it is suspected to have been re-drilled, check orifice hole with a numbered drill bit of correct size. Never re-drill an orifice. A burr-free and squarely aligned orifice hole is essential for proper flame characteristics. See Fig. 26.

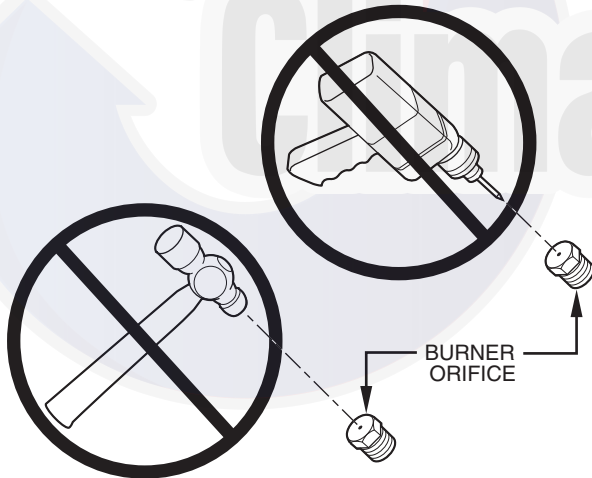

Fig. 26 — Orifice Hole

Step 11 — Install External Condensate Trap and Line

The unit has one 3/4-in. condensate drain connection on the end of the condensate pan and an alternate connection on the bottom. See Fig. 27. Unit airflow configuration does not determine which drain connection to use. Either drain connection can be used with vertical or horizontal applications.

To use the alternate bottom drain connection, remove the red drain plug from the bottom connection (use a 1/2-in. square socket drive extension) and install it in the side drain connection.

The piping for the condensate drain and external trap can be completed after the unit is in place. See Fig. 28.

All units must have an external trap for condensate drainage. Install a trap at least 4-in. (102 mm) deep and protect against freeze-up. If drain line is installed downstream from the external trap, pitch the line away from the unit at 1-in. per 10 ft

(25 mm in 3 m) of run. Do not use a pipe size smaller than the unit connection (3/4-in.).

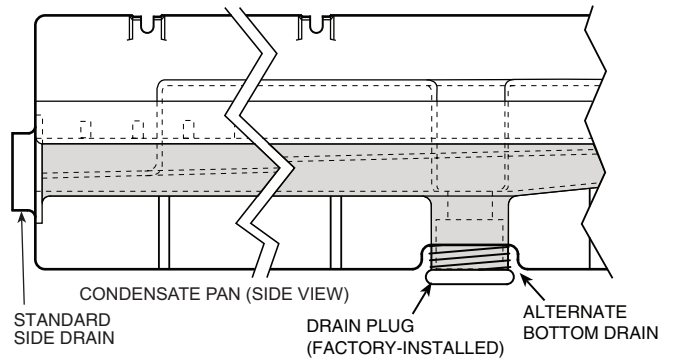
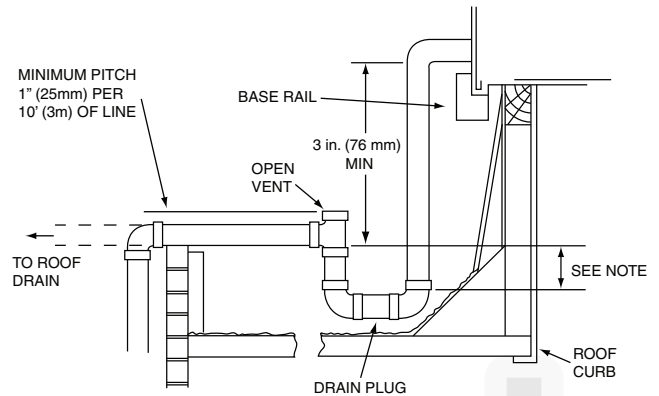

Fig. 27 — Condensate Drain Pan (Side View)



NOTE: Trap should be deep enough to offset maximum unit static difference. A 4-in. (102 mm) trap is recommended.

Fig. 28 — Condensate Drain Piping Details

Step 12 — Make Electrical Connections

⚠ WARNING

ELECTRIC SHOCK HAZARD

Failure to follow this warning could result in personal injury or death.

Unit cabinet must have an uninterrupted, unbroken electrical ground to minimize the possibility of personal injury if an electrical fault should occur. This ground may consist of electrical wire connected to unit ground lug in control compartment, or conduit approved for electrical ground when installed in accordance with NEC; ANSI/NFPA 70, latest edition (in Canada, Canadian Electrical Code CSA [Canadian Standards Association] C22.1), and local electrical codes.

NOTE: Field-supplied wiring shall conform with the limitations of minimum 63°F (33°C) rise.

FIELD POWER SUPPLY

For those units without through-the-curb power, conduit must be used to route the main power from the condenser end, via the power entry in the corner post of the unit (see Fig. 29 and 30) to either the factory option disconnect or the bottom of the control box. A one-inch conduit is provided wrapped around compressor. A second conduit is provided with factory-installed powered convenience outlet. For those units that require conduit larger than 1-in., it must be field supplied. Fig. 29 and 30 show the wire routings.

If the field disconnect is larger than 100A, it must be attached to the unit using accessory CRDISBKT001A00 — disconnect switch bracket (see Fig. 31). Follow the instructions provided with this accessory. For smaller field disconnects, be sure to use 1/2-in. screws to mount the disconnect directly to the end panel (see Fig. 32). In either case, set the disconnect vertical location on the unit so that a 90 degree fitting can be used to connect the conduit to the disconnect.

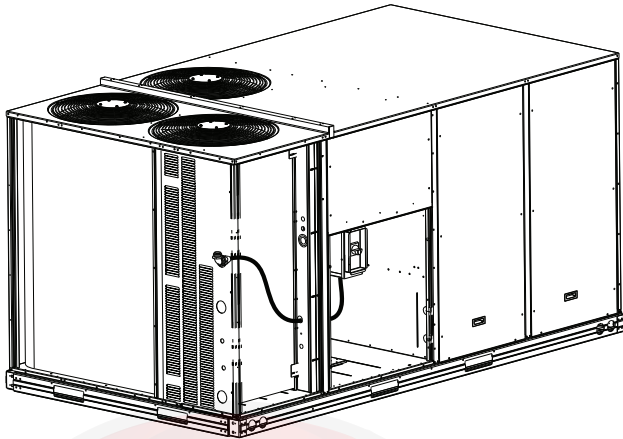

Fig. 29 — Conduit into Factory Option Non-Fused Disconnect (NFD) or HACR

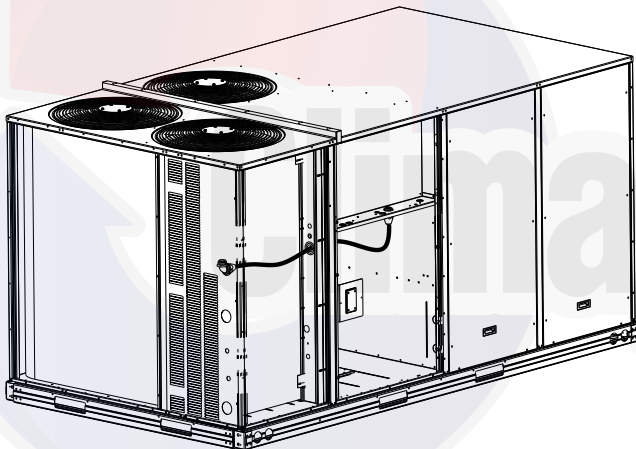

Fig. 30 — Conduit into Control Box

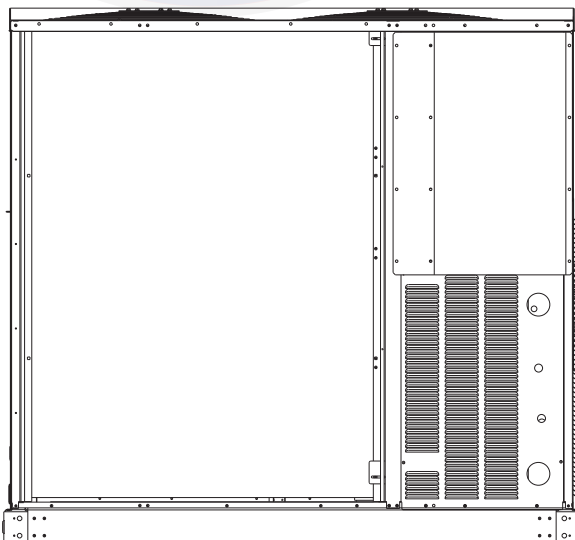

Fig. 31 — Mounting Position for Field Disconnects (over 100A)

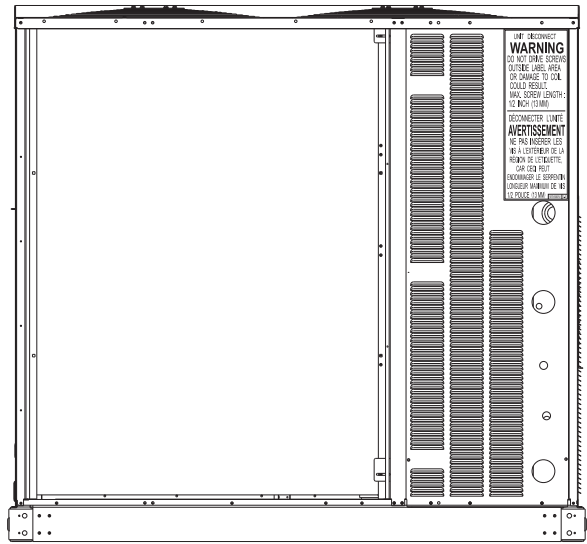

Fig. 32 — Mounting Position for Field Disconnects (up to 100A)

Field power wires are connected to the unit at line-side pressure lugs at the main terminal block (TB1) or at factory-installed option non-fused disconnect switch or HACR. Refer to Table 7 for maximum wire size at connection lugs. Use copper wire only. See Fig. 33.

NOTE: TEST LEADS - Unit may be equipped with short leads (pigtailed) on the field line connection points off the optional non-fused disconnect switch or HACR. These leads are for factory run-test purposes only; remove and discard before connecting field power wires to unit connection points. Make field power connections directly to line connection pressure lugs only.

Table 7 — Connection Lug Min/Max Wire Sizes

	MINIMUM	MAXIMUM
TB1 in unit control box	#14	#1
80A Disconnect Option	#14	#4
100A Disconnect Option	#8	1/0
25A HACR Option	#14	1/0
30A HACR Option	#14	1/0
35A HACR Option	#14	1/0
40A HACR Option	#14	1/0
50A HACR Option	#14	1/0
60A HACR Option	#14	1/0
70A HACR Option	#14	1/0
80A HACR Option	#14	1/0
90A HACR Option	#14	1/0
100A HACR Option	#14	1/0

⚠ WARNING

FIRE HAZARD

Failure to follow this warning could result in personal injury, death, or property damage.

Do not connect aluminum wire between disconnect switch and unit. Use only copper wire.

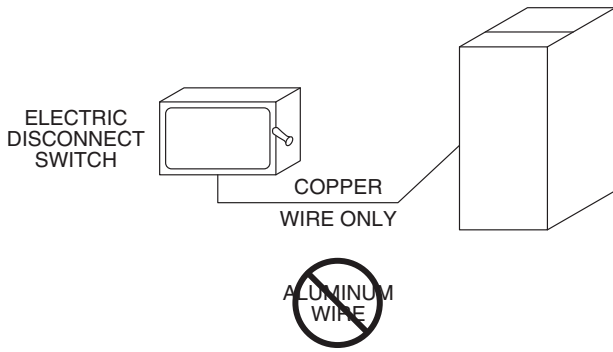

Fig. 33 — Disconnect Switch and Unit

ALL UNITS

All field wiring must comply with NEC and all local requirements. See Fig. 34-38 for wiring diagrams.

Size wire based on MCA (Minimum Circuit Amps) on the unit informative plate. See Fig. 39 and the unit label diagram for power wiring connections to the unit power terminal blocks and equipment ground. Refer to Table 7 for maximum wire size at connection lugs.

Provide a ground-fault and short-circuit over-current protection device (fuse or breaker) per NEC Article 440 (or local codes). Refer to unit informative data plate for MOCP (Maximum Over-current Protection) device size.

NOTE: Units ordered with factory-installed HACR do not need an additional ground-fault and short-circuit over-current protection device unless local codes require.

Voltage to compressor terminals during operation must be within voltage range indicated on unit nameplate. On 3-phase units, voltages between phases must be balanced within 2% and the current within 10%. Use the formula shown below to determine the percent of voltage imbalance.

$$\% \text{ Voltage Imbalance} = 100 \times \frac{\text{max voltage deviation from average voltage}}{\text{average voltage}}$$

Example: Supply voltage is 230-3-60

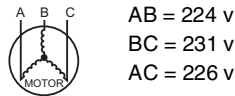

$$\text{Average Voltage} = \frac{(224 + 231 + 226)}{3} = \frac{681}{3} = 227$$

Determine maximum deviation from average voltage.

(AB) 227-224 = 3 v

(BC) 231-227 = 4 v

(AC) 227-226 = 1 v

Maximum deviation is 4 v.

Determine percent of voltage imbalance.

$$\% \text{ Voltage Imbalance} = 100 \times \frac{4}{227} = 1.78\%$$

This amount of phase imbalance is satisfactory as it is below the maximum allowable 2%.

IMPORTANT: If the supply voltage phase imbalance is more than 2%, contact your local electric utility company immediately.

All units except 208/230-v units are factory wired for the voltage shown on the nameplate. If the 208/230-v unit is to be connected to a 208-v power supply, the control transformer must be rewired by moving the black wire with the 1/4-in. female spade connector from the 230-v connection and moving it to the 200-v 1/4-in. male terminal on the primary side of the transformer. Refer to unit label diagram for additional information.

⚠ CAUTION

UNIT DAMAGE HAZARD

Failure to follow this caution may result in equipment damage. Operation on improper line voltage or excessive phase imbalance constitutes abuse and may cause damage to electrical components. Such operation would invalidate any applicable Carrier warranty.

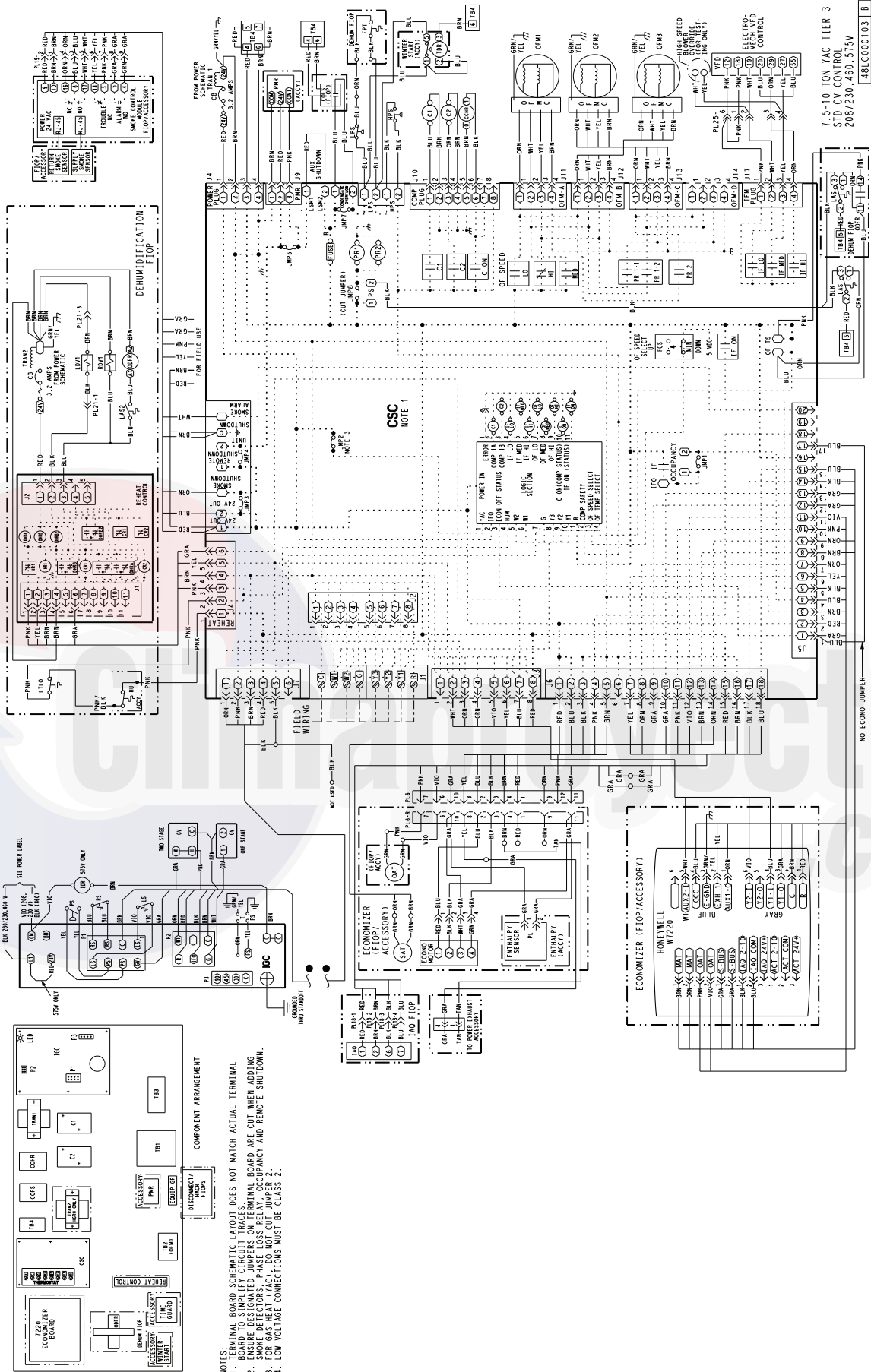
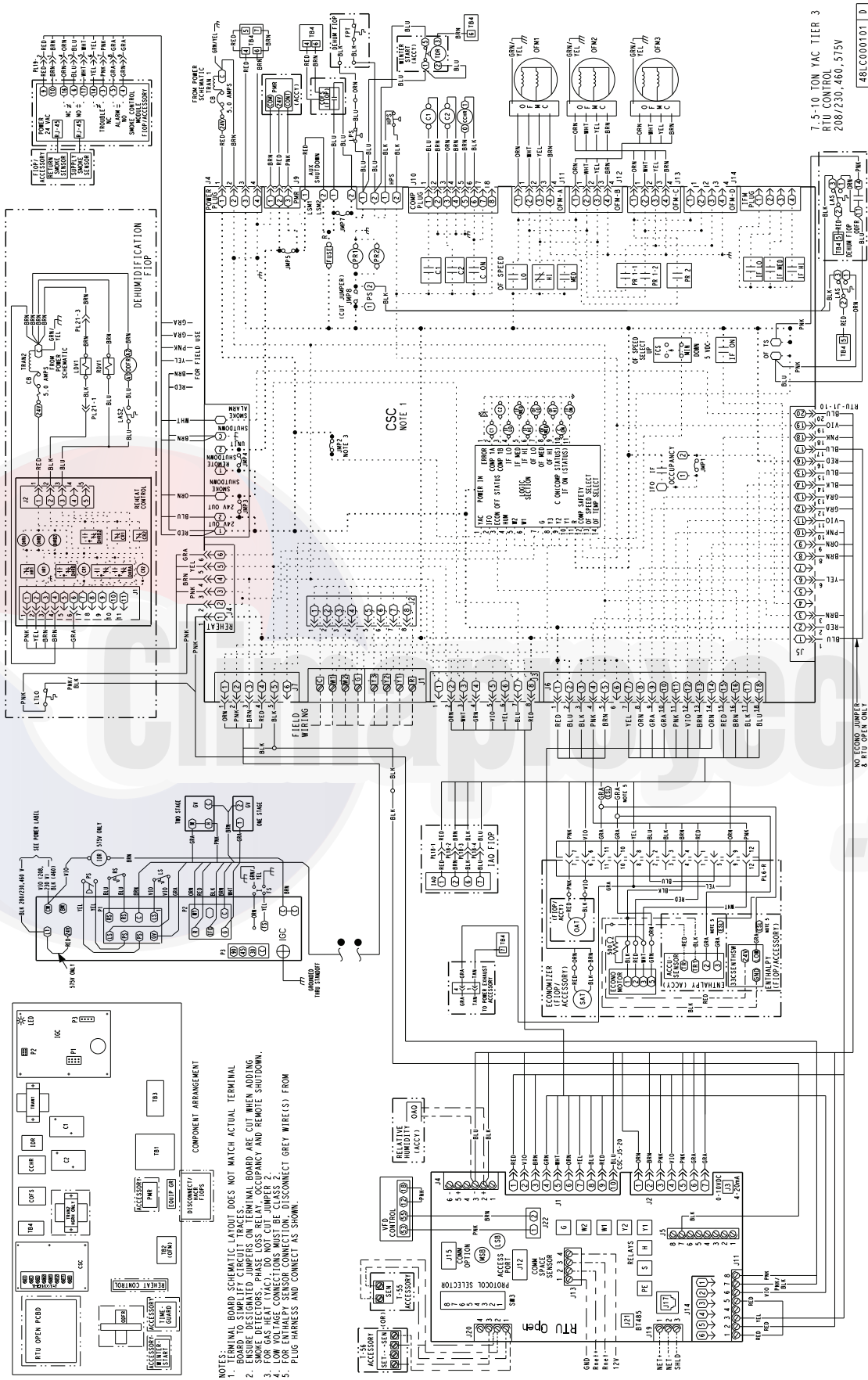
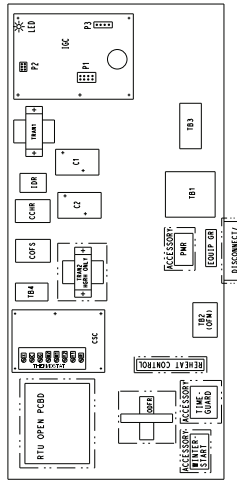

Fig. 34 — 48LC 08-12 Electro-mechanical Control Wiring Diagram



7.5-10 TON YAC TIER 3
RTU CONTROL
208/230/460/575V
48LC00101.D



- NOTES:
1. TERMINAL BOARD SCHEMATIC LAYOUT DOES NOT MATCH ACTUAL TERMINAL BOARD LAYOUT.
 2. SENSORS DESIGNATED JUMPERS ON TERMINAL BOARD ARE CUT WHEN ADDING SMOKE DETECTORS, PHASE LOSS RELAY, OCCUPANCY AND REMOTE SHUTDOWN.
 3. SMOKE DETECTORS, PHASE LOSS RELAY, OCCUPANCY AND REMOTE SHUTDOWN.
 4. LOW VOLTAGE CONNECT LINES MUST BE CLASS 2.
 5. FOR ENTHALPY SENSOR CONNECTION, DISCONNECT GREY WIRE(S) FROM PLUG HARNESS AND CONNECT AS SHOWN.

Fig. 35 — 48LC 08-12 RTU Open Control Wiring Diagram

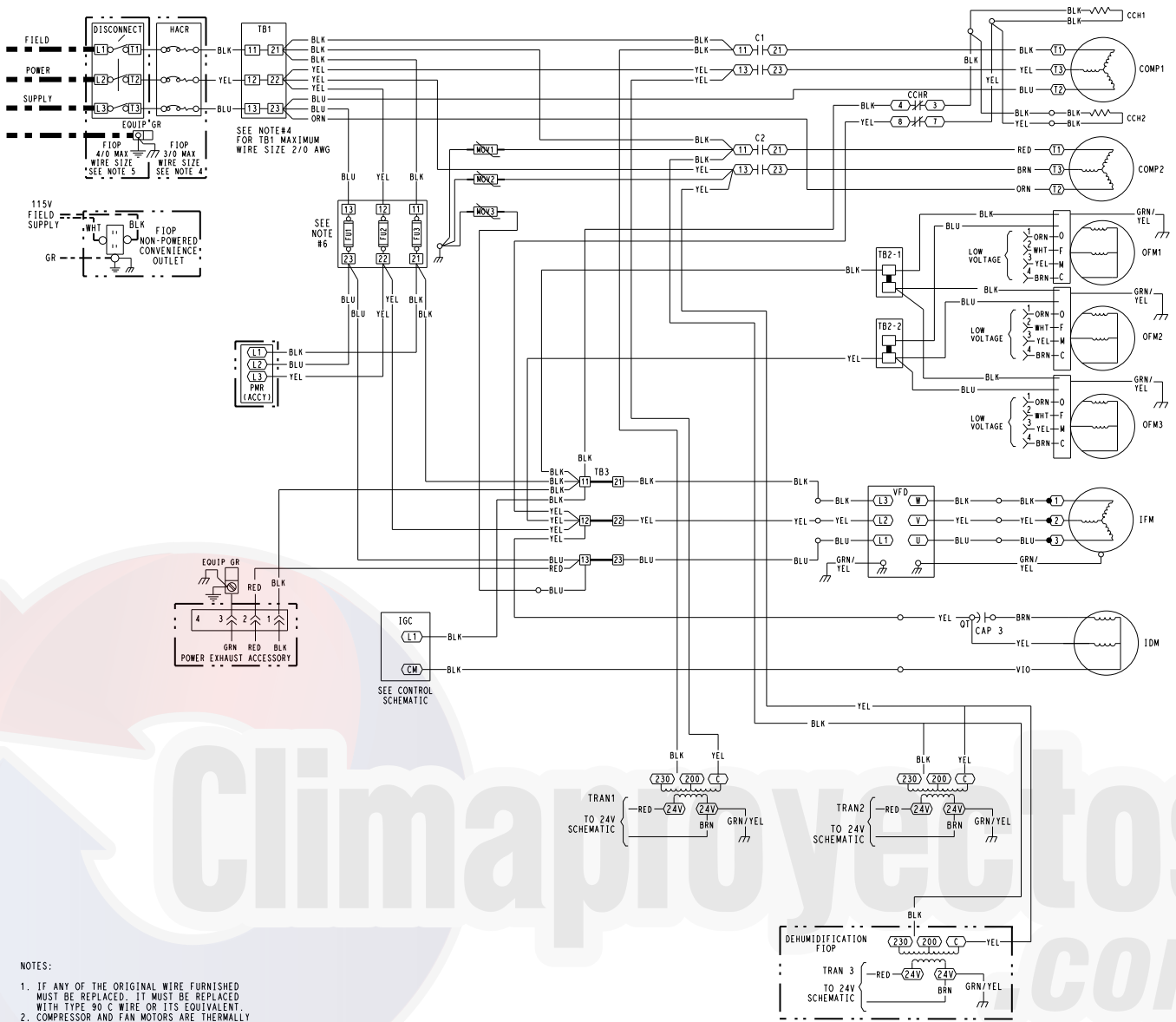

- NOTES:
1. IF ANY OF THE ORIGINAL WIRE FURNISHED MUST BE REPLACED. IT MUST BE REPLACED WITH TYPE 90 C WIRE OR ITS EQUIVALENT.
 2. COMPRESSOR AND FAN MOTORS ARE THERMALLY PROTECTED. THREE PHASE MOTORS ARE PROTECTED AGAINST PRIMARY SINGLE PHASING CONDITIONS.
 3. USE COPPER, COPPER CLAD ALUMINUM OR ALUMINUM CONDUCTORS.
 4. USE COPPER CONDUCTORS ONLY.
 5. FU1, 2, 3 REPLACE WITH 250V 60A BUSSMAN FRNR 60.

YAC POWER TIER3-7.5,8.5,10 TON
208/230V 3Ø PIC
48LC500552 B

Fig. 38 — 48LC 08-12 Typical Power Wiring Diagram, SystemVu™ Control (208/230-v Unit Shown)

UNITS WITHOUT FACTORY-INSTALLED NON-FUSED DISCONNECT OR HACR

When installing units, provide a disconnect switch of adequate size per NEC (National Electrical Code). Disconnect sizing data is provided on the unit informative plate. Locate on unit cabinet or within sight of the unit per national or local codes. Do not cover unit informative plate if mounting the disconnect on the unit cabinet.

UNITS WITH FACTORY-INSTALLED NON-FUSED DISCONNECT OR HACR

The factory-installed option non-fused disconnect (NFD) switch (see Fig. 40) or HACR (see Fig. 42) is located in a weatherproof enclosure located under the main control box. The manual switch handle is shipped in the disconnect or HACR enclosure. Assemble the shaft and handle to the switch or HACR at this point. Discard the factory test leads (see Fig. 39). The factory disconnect is either an 80A or 100A depending on the unit voltage, indoor motor and options.

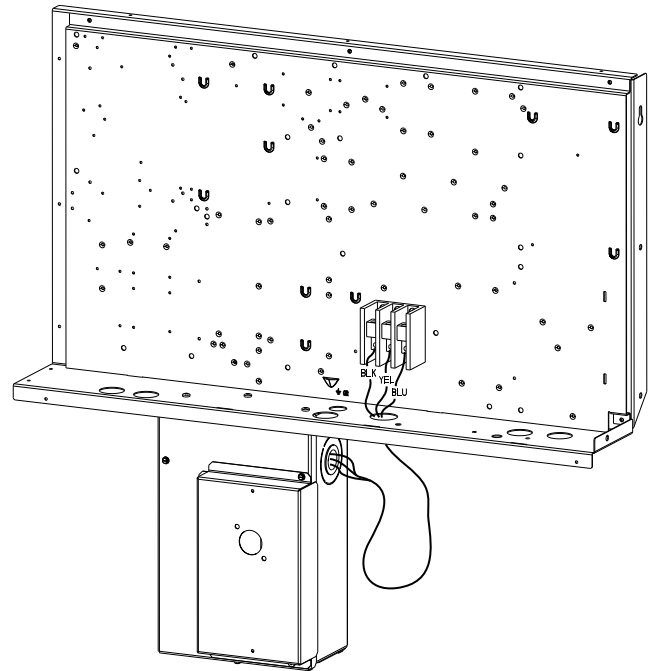
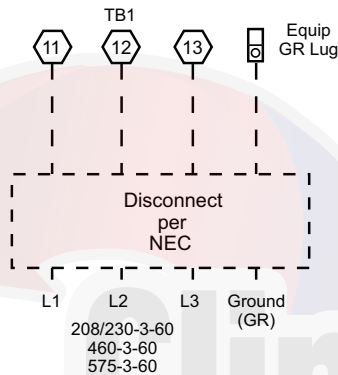

Fig. 40 — Location of Non-Fused Disconnect Enclosure

Units Without Disconnect or HACR Option



Units With Disconnect or HACR Option

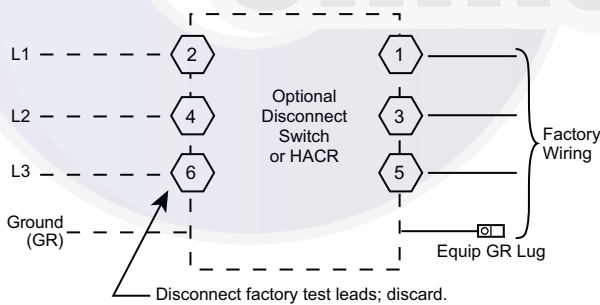

Fig. 39 — Power Wiring Connections

To field install the NFD shaft and handle

1. Remove the unit front panel (see Fig. 2 and 3).
2. Remove (3) hex screws on the NFD enclosure - (2) on the face of the cover and (1) on the bottom (see Fig. 41).
3. Remove the front cover of the NFD enclosure.
4. Make sure the NFD shipped from the factory is at OFF position (the arrow on the black handle knob is at OFF).
5. Insert the shaft with the cross pin on the top of the shaft in the horizontal position.
6. Measure the tip of the shaft to the top surface of the pointer to be 3.75 to 3.88 in. (95 to 99 mm) for 80A and 100A NFD and 3.43 to 3.56 in. (87 to 90 mm) for 200A NFD.
7. Tighten the locking screw to secure the shaft to the NFD.
8. Turn the handle to the OFF position with red arrow pointing at OFF.
9. Install the handle on to the painted cover horizontally with the red arrow pointing to the left.
10. Secure the handle to the painted cover with (2) screws and lock washers supplied.
11. Engaging the shaft into the handle socket, re-install (3) hex screws on the NFD enclosure.
12. Re-install the unit front panel.

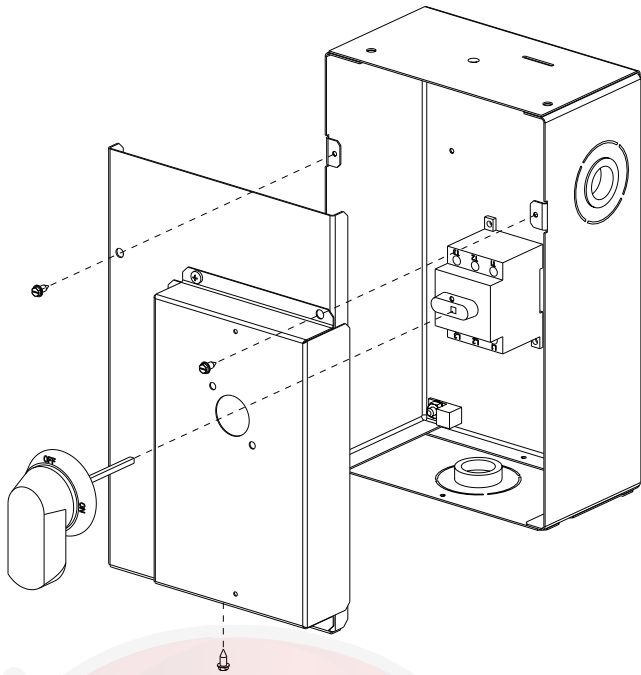

Fig. 41 — Handle and Shaft Assembly for NFD

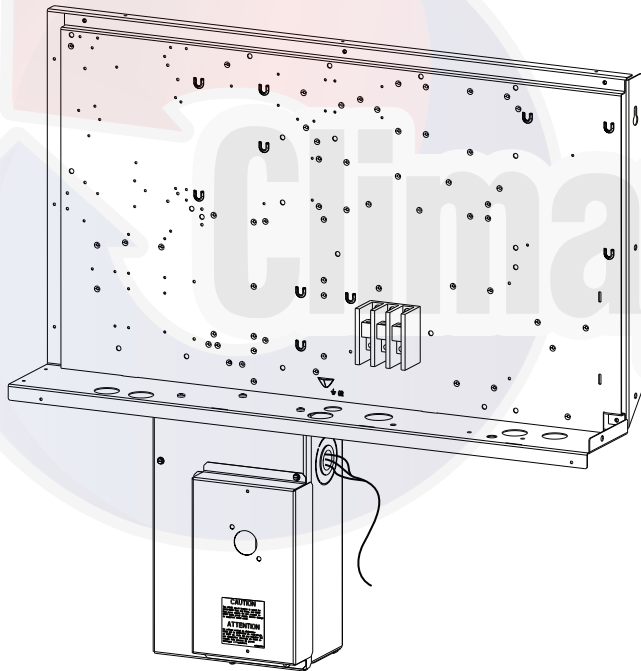

Fig. 42 — Location of HACR Enclosure

To field install the HACR shaft and handle

1. Remove the unit front panel (see Fig. 2 and 3).
2. Remove (3) hex screws on the HACR enclosure - (2) on the face of the cover and (1) on the bottom (see Fig. 43).
3. Remove the front cover of the HACR enclosure.
4. Make sure the HACR shipped from the factory is at OFF position (the white arrow pointing at OFF).
5. Insert the shaft all the way with the cross pin on the top of the shaft in the horizontal position.
6. Tighten the locking screw to secure the shaft to the HACR.
7. Turn the handle to the OFF position with red arrow pointing at OFF.
8. Install the handle on to the painted cover horizontally with the red arrow pointing to the left.

9. Secure the handle to the painted cover with (2) screws and lock washers supplied.
10. Engaging the shaft into the handle socket, re-install (3) hex screws on the HACR enclosure.
11. Re-install the unit front panel.

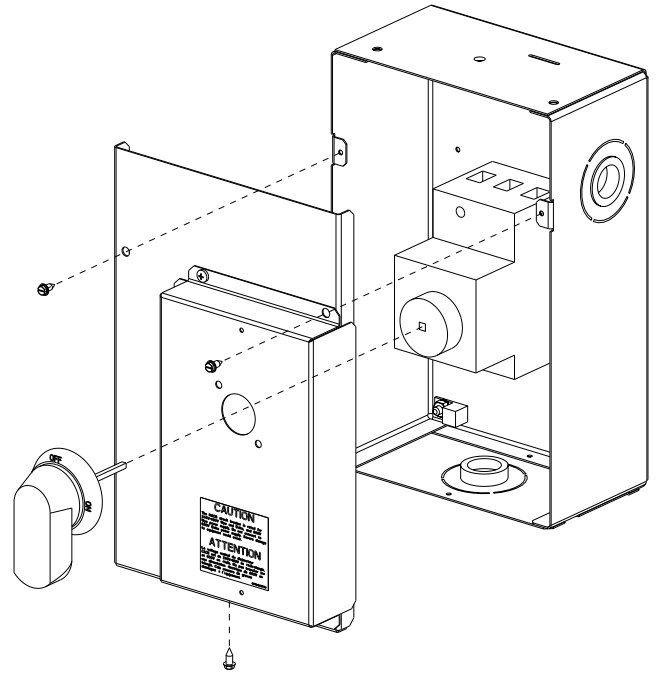

Fig. 43 — Handle and Shaft Assembly for HACR

CONVENIENCE OUTLETS

⚠ WARNING

ELECTRICAL OPERATION HAZARD

Failure to follow this warning could result in personal injury or death.

Units with convenience outlet circuits may use multiple disconnects. Check convenience outlet for power status before opening unit for service. Locate its disconnect switch, if appropriate, and open it. Lock-out and tag-out this switch, if necessary.

Two types of convenience outlets are offered on 48LC units: non-powered and unit-powered. Both types provide a 125-v GFCI (ground-fault circuit-interrupter) duplex receptacle rated at 15-A behind a hinged waterproof access cover, located on the panel beneath the control box. See Fig. 44 and 45.

Non-powered type

This type requires the field installation of a general-purpose 125-volt 15-A circuit powered from a source elsewhere in the building. Observe national and local codes when selecting wire size and conduit requirements, fuse or breaker requirements and disconnect switch size and location. Route 125-v power supply conductors into the bottom of the utility box containing the duplex receptacle.

Unit-powered type

A unit-mounted transformer is factory-installed to stepdown the main power supply voltage to the unit to 115-v at the duplex receptacle. This option also includes a manual switch with fuse, located in a utility box and mounted on a bracket behind the convenience outlet; access is through the panel beneath the control box. See Fig. 44.

The primary leads to the convenience outlet transformer are not factory-connected. Selection of primary power source is a customer option. If local codes permit, the transformer primary leads can

be connected at the line-side terminals on the unit-mounted non-fused disconnect; this will provide service power to the unit when the unit disconnect switch is open. Other connection methods will result in the convenience outlet circuit being de-energized when the unit disconnect switch is open. See Fig. 46. On a unit without a unit-mounted disconnect, connect the source leads to the main terminal block (TB1).

If the convenience outlet transformer is connected to the line side of a field disconnect, the conduit provided with the unit must be used to protect the wire as they are routed from the transformer to the field disconnect. The end of the conduit with the straight connector attaches to the field disconnect. The other end does not need to connect to the transformer; however, the conduit must be routed so that all wiring is either in the conduit or behind the access panel.

If the convenience outlet transformer is connected to the line side of the factory disconnect option, route the wires through the web bushing located on the bottom of the disconnect box. For the load side wiring to the factory option disconnect, route the wires through the hole on the right side of the disconnect. Be sure to create a drip loop at least 6-in. long.

Test the GFCI receptacle by pressing the TEST button on the face of the receptacle to trip and open the receptacle. Check for proper grounding wires and power line phasing if the GFCI receptacle does not trip as required. Press the RESET button to clear the tripped condition.

Fuse on power type: The factory fuse is a Bussman¹ “Fusetron” T-15, non-renewable screw-in (Edison base) type plug fuse.

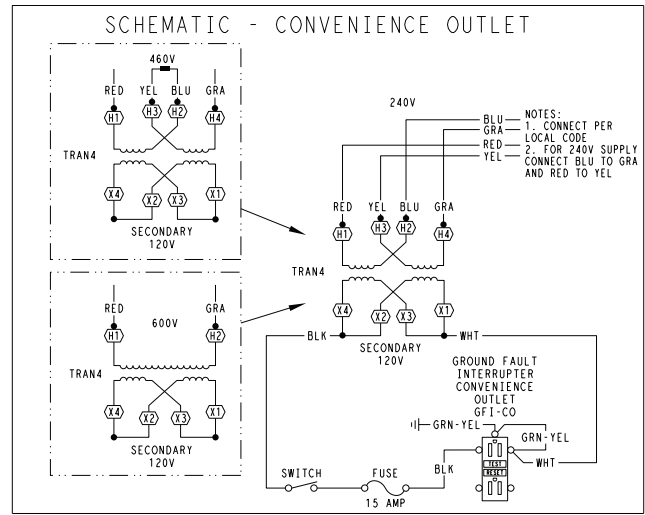

UNIT VOLTAGE	CONNECT AS	PRIMARY CONNECTIONS	TRANSFORMER TERMINALS
208, 230	240	L1: RED + YEL L2: BLU + GRA	H1 + H3 H2 + H4
460	480	L1: RED Splice BLU + YEL L2: GRA	H1 H2 + H3 H4
575	600	L1: RED L2: GRA	H1 H2

Fig. 46 — Unit Powered Convenience Outlet Wiring

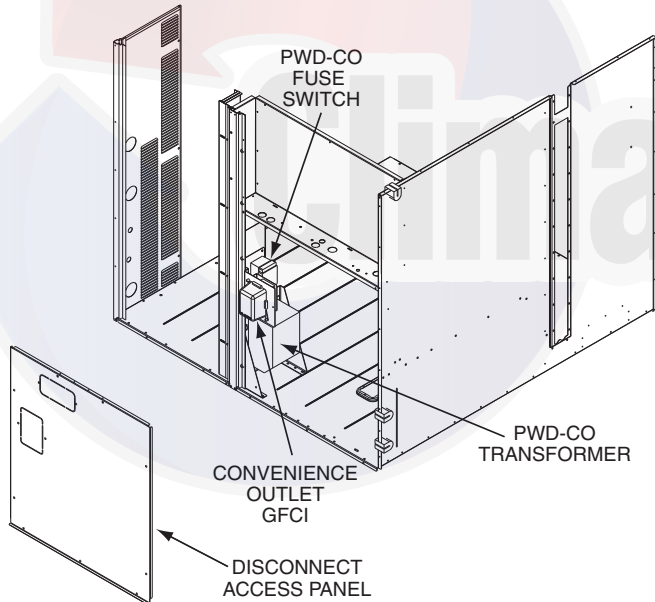

Fig. 44 — Convenience Outlet Location

NOTICE/AVIS

Convenience Outlet Utilization
 Maximum Intermittent Use 15 - Amps
 Maximum Continuous Use 8 - Amps
 Observe a 50% limit on the circuit
 Loading above 8 - Amps

Utilisation de la prise utilitaire
 Usage intermittent maximum 15 - Amps
 Usage continu maximum 8 - Amps
 Observez une limite de 50% sur le circuit
 Chargement au-dessus de 8 - Amps

50HE501288 2.0

Fig. 45 — Convenience Outlet Utilization Notice

⚠ WARNING

ELECTRICAL OPERATION HAZARD

Failure to follow this warning could result in personal injury or death.

Using unit-mounted convenience outlets: Units with unit-mounted convenience outlet circuits will often require that two disconnects be opened to de-energize all power to the unit. Treat all units as electrically energized until the convenience outlet power is also checked and de-energization is confirmed. Observe National Electrical Code Article 210, Branch Circuits, for use of convenience outlets.

Installing Weatherproof Cover

A weatherproof while-in-use cover for the factory-installed convenience outlets is now required by UL standards. This cover cannot be factory-mounted due to its depth; it must be installed at unit installation. For shipment, the convenience outlet is covered with a blank cover plate.

The weatherproof cover kit is shipped in the unit’s control box. The kit includes the hinged cover, a backing plate and gasket.

DISCONNECT ALL POWER TO UNIT AND CONVENIENCE OUTLET. LOCK-OUT AND TAG-OUT ALL POWER.

Remove the blank cover plate at the convenience outlet; discard the blank cover.

Loosen the two screws at the GFCI duplex outlet, until approximately 1/2-in. (13 mm) under screw heads is exposed. Press the gasket over the screw heads. Slip the backing plate over the screw heads at the keyhole slots and align with the gasket; tighten the two screws until snug (do not over-tighten).

Mount the weatherproof cover to the backing plate as shown in Fig. 47. Remove two slot fillers in the bottom of the cover to permit service tool cords to exit the cover. Check for full closing and latching.

1. Bussman and Fusetron are trademarks of Cooper Technologies Company.

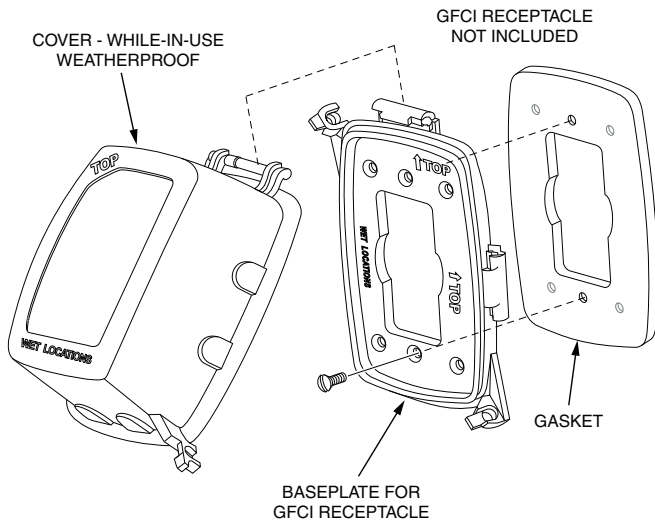

Fig. 47 — Weatherproof Cover Installation

HACR

The amp rating of the HACR factory-installed option is based on the size, voltage, indoor motor and other electrical options of the unit as shipped from the factory. If field-installed accessories are added or changed in the field (i.e., power exhaust), the HACR may no longer be of the proper amp rating and therefore will need to be removed from the unit. See unit nameplate and label on factory-installed HACR for the amp rating of the HACR that was shipped with the unit from the factory. See unit nameplates for the proper fuse, HACR or maximum over-current protection device required on the unit with field-installed accessories. See Fig. 48.

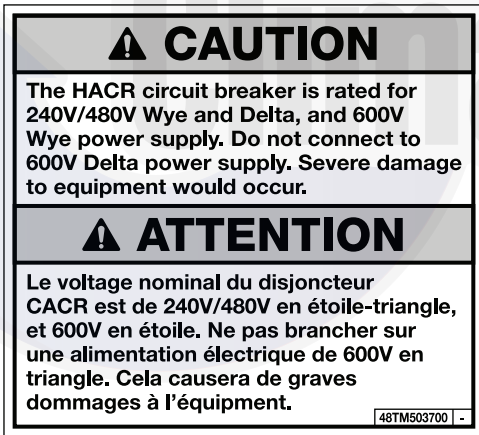

Fig. 48 — HACR Caution Label

FACTORY-OPTION THRU-BASE CONNECTIONS (ELECTRICAL CONNECTIONS)

This service connection kit consists of a 1/2-in. electrical bulkhead connector and a 1 1/2-in. electrical bulkhead connector, connected to an “L” bracket covering the embossed (raised) section of the unit basepan in the condenser section. See Fig. 49. The 1/2-in. bulkhead connector enables the low-voltage control wires to pass through the basepan. The 1 1/2-in. electrical bulkhead connector allows the high-voltage power wires to pass through the basepan.

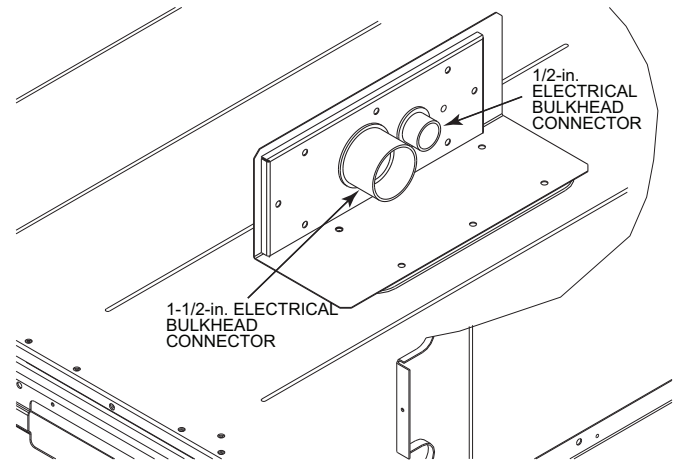

Fig. 49 — Thru-the-Base Option, Shipping Position

1. Remove the “L” bracket assembly from the unit.
2. Remove connector plate assembly from the “L” bracket and discard the “L” bracket, but retain the washer head screws and the gasket (located between the “L” bracket and the connector plate assembly).

NOTE: Take care not to damage the gasket, as it is reused in the following step.

3. Place the gasket over the embossed area in the basepan, aligning the holes in the gasket to the holes in the basepan. See Fig. 50.
4. Install the connector plate assembly to the basepan using 8 of the washer head screws.

NOTE: If electrical connections are not going to occur at this time, tape or otherwise cover the fittings so that moisture does not get into the building or conduit in the interim.

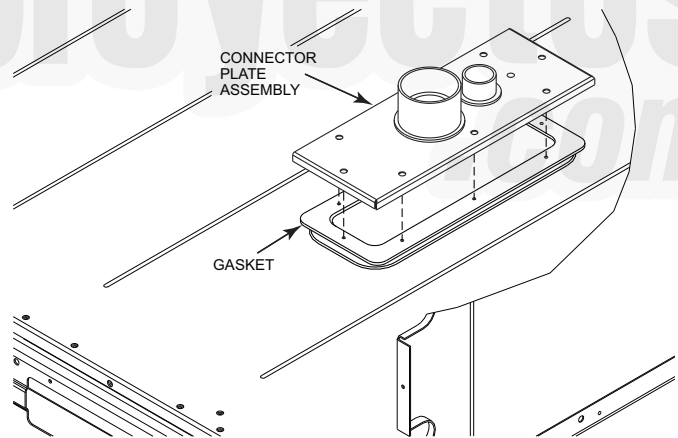

Fig. 50 — Completing Installation of Thru-the-Base Option

Check tightness of connector lock nuts before connecting electrical conduits.

Field-supplied and field-installed liquid tight conduit connectors and conduit may be attached to the connectors on the basepan. Pull correctly rated high voltage and low voltage through appropriate conduits. Connect the power conduit to the internal disconnect (if unit is so equipped) or to the external disconnect (through unit side panel). A hole must be field cut in the main control box bottom on the left side so the 24-v control connections can be made. Connect the control power conduit to the unit control box at this hole.

UNITS WITHOUT THRU-BASE CONNECTIONS

1. Install power wiring conduit through side panel openings. Install conduit between disconnect and control box.
2. Install power lines to terminal connections as shown in Fig. 39.

FIELD CONTROL WIRING

The 48LC unit requires an external temperature control device such as a thermostat (field-supplied).

THERMOSTAT

Install a Carrier-approved accessory thermostat according to installation instructions included with the accessory. For complete economizer function and 3-stage compressor operation select a three-stage cooling thermostat. If a 3-stage cooling thermostat is not available, use a 2-stage cooling thermostat instead, but note that this will limit cooling to just 2 stages. Locate the thermostat accessory on a solid wall in the conditioned space to sense average temperature in accordance with the thermostat installation instructions.

If the thermostat contains a logic circuit requiring 24-v power, use a thermostat cable or equivalent single leads of different colors with minimum of eight leads. If the thermostat does not require a 24-v source (no "C" connection required), use a thermostat cable or equivalent with minimum of seven leads. Check the thermostat installation instructions for additional features which might require additional conductors in the cable. See Fig. 51.

For wire runs up to 50 ft (15 m), use no. 18 AWG (American Wire Gage) insulated wire (35°C minimum). For 50 to 75 ft (15 to 23 m), use no. 16 AWG insulated wire (35°C minimum). For over 75 ft (23 m), use no. 14 AWG insulated wire (35°C minimum). All wire sizes larger than no. 18 AWG cannot be directly connected to the thermostat and will require a junction box and splice at the thermostat.

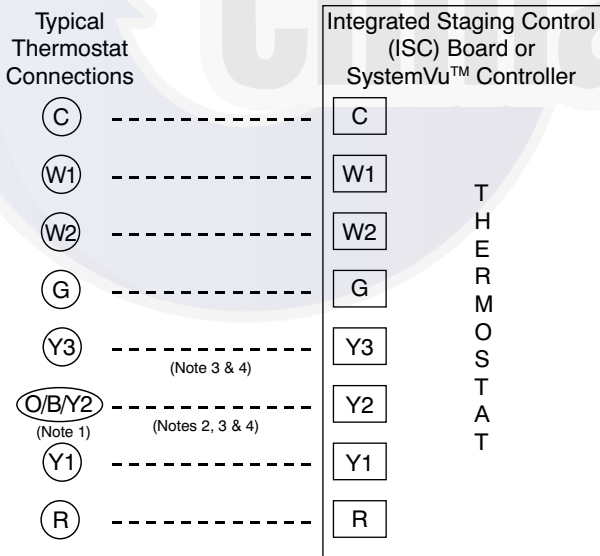

- Note 1: Typical multi-function marking. Follow manufacturer's configuration Instructions to select Y2.
- Note 2: Y2 to Y3 connection required for 2-stage cooling operation and when integrated economizer function is desired.
- Note 3: To Connect a 2-Stage Thermostat:
Y2 to Y3 connection required for 2-stage cooling operation which provides low and high cooling states.
- Note 4: SystemVu controller is default configured for 3-stage cooling and 2-stage heating thermostats; it can be configured for other thermostat types.
- Field Wiring

Fig. 51 — Typical Low-Voltage Control Connections

UNIT WITHOUT THRU-BASE CONNECTION KIT

Pass the thermostat control wires through the bushing on the unit end panel. Route the wire through the snap-in wire tie and up to the web bushing near the control box. Route the wire through the bushing and into the bottom left side of the control box after removing one of the two knockouts in the corner of the box. Using a connector at the control box to protect the wire as it passes into the control box pull the wires over to the terminal strip at the lower left corner of the Integrated Staging Control (ISC) Board. Use the connector at the control box and the wire tie to take up any slack in the thermostat wire to ensure that it will not be damaged by contact with the condenser coil. See Fig. 52.

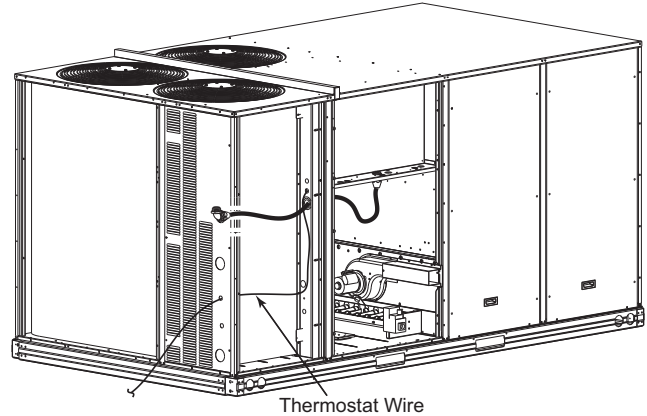

Fig. 52 — Thermostat Wire Routing

NOTE: If thru-the-bottom connections accessory is used, refer to the accessory installation instructions for information on routing power and control wiring.

HEAT ANTICIPATOR SETTINGS

Set heat anticipator settings at 0.14 amp for the first stage and 0.14 amp for second-stage heating, when available.

Humidi-MiZer® System Control Connections

NOTE: It is suggested to ensure the Auto-Changeover function of an installed thermostat is enabled when used in conjunction with the Humidi-MiZer Adaptive Dehumidification system.

HUMIDI-MIZER SYSTEM – SPACE RH CONTROLLER

The Humidi-MiZer dehumidification system requires a field-supplied and installed space relative humidity control device. This device may be a separate humidistat control (contact closes on rise in space RH above control setpoint) or a combination thermostat-humidistat control device with isolated contact set for dehumidification control. See Fig. 53.

NOTE: Use of a humidistat device is not permitted on 48LC units equipped with RTU Open control; these units require use of a field-supplied RH sensor (33ZCSENSRH-02 or 33ZHCSEN-DRH-02), or a ZS series sensor with humidity sensing. SystemVu™ controls requires a Space Humidistat (HL38MG029), a Wall Mount Space Humidity Sensor (33ZCSENSRH-01), or a Duct Mount Humidity Sensor (33ZCSENDRH-01).

To connect the Carrier humidistat (HL38MG029)

1. Route the humidistat 2-conductor cable (field-supplied) through the bushing in the unit's louvered end panel (see Fig. 52).
2. Route the cable through the snap-in wire tie and up to the web bushing near the control box.
3. Feed the cable through the bushing and into the bottom left side of the control box after removing one of the two knockouts in the corner of the box. Use a connector to protect the cable as it enters the control box.

4. Use the connector and the wire tie to reduce any slack in the humidistat cable to ensure that it will not be damaged by contact with the condenser coil (see Fig. 52).
5. Use wire nuts to connect humidistat cable to the leads in the low-voltage wiring (as shown in Fig. 54), connecting PNK to PNK and PNK/BLK to PNK/BLK.

NOTE: 48LC**08/09/12 units require a 3-stage cooling thermostat device and are not compatible with Carrier's Edge® Pro thermostat.

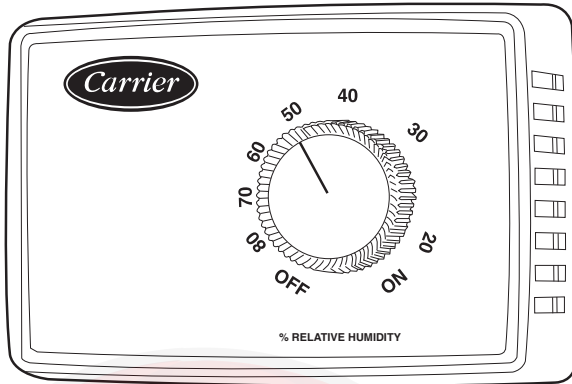

Fig. 53 — Accessory Field-Installed Humidistat

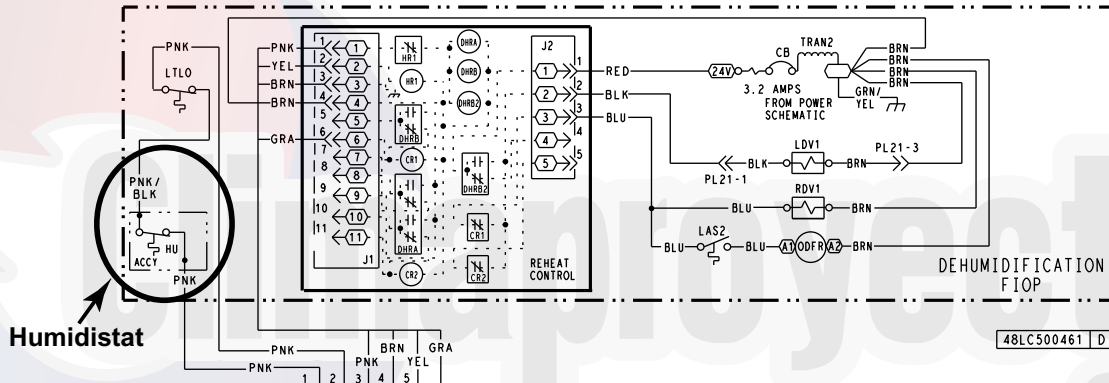

Fig. 54 — Typical Humidi-MiZer Adaptive Dehumidification System Humidistat Wiring

RTU Open Controller (Factory-Installed Option)

For details on operating 48LC**08/09/12 units equipped with the factory-installed RTU Open option, refer to *48/50LC 07-26 Factory Installed Option RTU Open Multi-Protocol Controller Controls, Start-up, Operation and Troubleshooting* manual.

SystemVu™ Controller (Factory-Installed Option)

For details on operating 48LC**08/09/12 units equipped with the factory-installed SystemVu control option, refer to *48/50LC 04-26 Single Package Rooftop Units with SystemVu Controls Version 2.X Controls, Start-up, Operation and Troubleshooting* manual.

Integrated Staging Control (ISC) Board

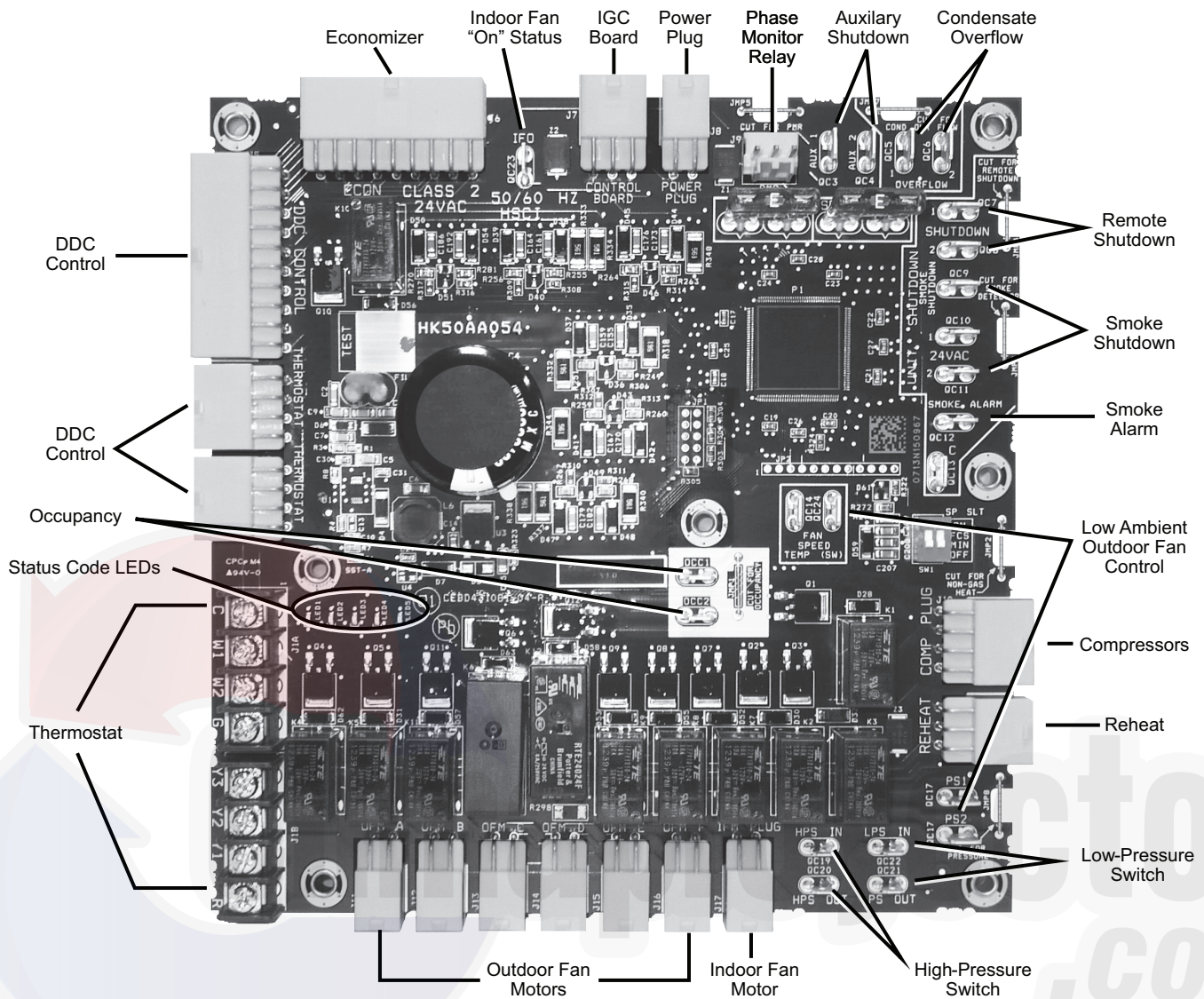

Fig. 55 — Integrated Staging Control (ISC) Board

Table 8 — Status Code Descriptions for ISC Board LEDs

ERROR #	ERROR NAME	LED INDICATION					
		LED01	LED02	LED03	LED04	LED05	
1	Check Smoke Detector/PMR/AUX		RED				
2	Check HPS/LPS/COFS	RED	RED				
3	Call for Y3 with no call for Y1. Check Y1 wiring.				RED		
4	Call for Y3 with no call for Y1/Y2. Check Y1 wiring.				RED	RED	
5	Call for Y2 with no call for Y1. Check Y1 wiring.		RED		RED		
6	Call for W2 with no call for W1. Check W1 wiring.	RED				RED	
7	Call for heat (W1/W2) and cooling (Y1/Y2/Y3). Check thermostat wiring.	RED	RED	Blinking Green LED (Note 1)	RED	RED	
8	Call for heat (W1/W2) with no G. Check G wiring.		RED		RED	RED	RED
9	Call for cooling (Y1/Y2/Y3) with no G. Check G wiring	RED	RED		RED		
10	Call for heat (W1/W2) and cooling (Y1/Y2/Y3) with no G. Check thermostat and G wiring.	RED	RED				RED
11	Check ISC Board and the thermostat wiring	RED				RED	RED
12	Check ISC Board and the thermostat wiring	RED					
13	Check ISC Board and the thermostat wiring	RED			RED		
14	Check ISC Board and the thermostat wiring					RED	
15	Check ISC Board and the thermostat wiring		RED			RED	

NOTES:

1. Green LED Blinking at 1Hz indicates normal operation.
2. Solid red LED indicates an error exists, see above LED configuration.

ISC BOARD - SEQUENCE OF OPERATION

General

The Carrier Integrated Staging Control (ISC) is intended for use with a standard thermostat or direct digital controls (DDC) capable of three cooling stages. After initial power to the board, a Green LED will blink with a 1 second duty cycle indicating the unit is running properly. In the event of the ISC board failing, the Green LED will be OFF or continuously ON. When the unit is not running properly, the Green LED will blink along with Red LED lights. The Red LED light configuration will indicate the type of error the board has identified. See Fig. 55 for LED locations and Table 8 for a list of status codes.

The ISC board can be remotely shutdown by removing Jumper 4 and wiring to the Remote Shutdown terminal. The Smoke Control Module can shutdown the unit by removing Jumper 3 and wiring to the Smoke Shutdown terminal. The Smoke Alarm terminal on the ISC Board provides a pass through connection should a smoke alarm signal be connected. In the case of the RTU Open option, the RTU Open controller provides the signal which is passed through the ISC board to the Smoke Alarm terminal.

The crankcase heater will run at all times, except when the compressors are running. An auxiliary power supply (24 vac) available at TB-4 Terminal is provided to power auxiliary equipment. An optional Phase Monitor Relay can be wired to the PMR terminal by removing Jumper 5. An optional Condensate Flow Switch can be wired to the COFS Terminal by removing Jumper 7.

Ventilation

In the Ventilation/Fan Mode (G on the thermostat), the indoor fan will run at low speed and the damper will operate at minimum position.

Cooling

In the Cooling Mode, the small and large compressors will be sequenced to maintain the thermostat temperature setpoint. The chart below shows the cooling operation based on the following conditions.

INPUT	OUTPUT			
Thermostat	Compressor C1	Compressor C2	Indoor Fan Speed	Outdoor Fan Speed
First Stage Cooling (Y1)	On	Off	Low	Low (700 rpm)
Second Stage Cooling (Y2)	Off	On	Medium	Medium (800 rpm)
Third Stage Cooling (Y3)	On	On	High	High (1000 rpm)

The outdoor fan and VFD controlled indoor-fan will operate at low, medium and high speed. The RPM is factory set by the CFM and static pressure requirements for the unit installed.

Humidi-MiZer® System (Optional)

In the Dehumidification Mode, both compressors will run and Indoor airflow will be rise to High Speed.

At subcooler reheating mode (reheat-1), during part load conditions when the room temperature and humidity are above the set point, the unit initiates the sub-cooling mode of operation; a call for cooling and dehumidification. RDV (Reheat Discharge Valve) and TWV (Three Way Valve) close; Indoor and Outdoor airflow will rise until reaching 100% of Speed.

At hot-gas-bypass reheating mode (reheat-2), when there is a call for dehumidification without a call for cooling, a portion of the hot gas from the compressor bypasses the condenser coil when RDV opens and hot gas is fed into the liquid line, TWV closes in this mode and the system provides mainly latent cooling. Indoor airflow will rise until reaching 100% of Speed, Outdoor airflow will run at High speed as long as outdoor temperature is above 80°F (26.7°C); when operating in this mode below 80°F (26.7°C) OAT,

the system outdoor fan will operate as shown in the table below based on size.

48LC SIZE	RPM	NUMBER OF FANS ON	NUMBER OF FANS OFF
08	160	2	1
09	160	2	1
12	160	2	1

Economizer (Optional)

When the economizer is in Free Cooling Mode and a demand for cooling exists (Y1 on the thermostat), the economizer will modulate the outdoor-air damper to provide a 50°F (10°C) to 55°F (13°C) mixed-air temperature into the zone and run the indoor fan at high speed. As mixed-air temperature fluctuates above 55°F (13°C) or below 50°F (10°C) dampers will be modulated (open or close) to bring the mixed-air temperature back within control. Upon more call for cooling (Y2 on the thermostat), the outdoor-air damper will maintain its current position, compressor C1 will run and the outdoor fan will run at low speed. If there is further demand for cooling, the outdoor-air damper will maintain its current position, compressor C2 will run and the outdoor fan will run at medium speed. The VFD-controlled indoor fan will operate at high speed regardless of the cooling demand.

If the increase in cooling capacity causes the mixed-air temperature to drop below 45°F (7°C), the outdoor-air damper will return to the minimum position. If the mixed-air temperature continues to fall, the outdoor-air damper will close. Control returns to normal once the mixed-air temperature rises above 48°F (9°C). The power exhaust fans will be energized and de-energized, if installed, as the outdoor-air damper opens and closes.

If field-installed accessory CO₂ sensors are connected to the Economizer, a demand controlled ventilation strategy will begin to operate. As the CO₂ level in the zone increases above the CO₂ setpoint, the minimum position of the damper will be increased proportionally. As the CO₂ level decreases because of the increase of fresh air, the outdoor-air damper will be proportionally closed. For economizer operation, there must be a thermostat call for the fan (G). If the unit is occupied and the fan is on, the damper will operate at minimum position. Otherwise, the damper will be closed.

Low Ambient Cooling Operation Down to 40°F (4°C)

In Low Ambient RTU conditions when the temperature is between 55°F (13°C) and 40°F (4°C), the Low Ambient Switch (LAS) will be active and the outdoor fans will run to the pre-set factory outdoor fan speed. When the temperature is greater than 65°F (18°C), the Low Ambient Switch will deactivate and the outdoor fans will run in the standard cooling mode. If the Outdoor Fan Select Switch (see Fig. 56) is in the ON position, the outdoor fans will run in the Fan Cycle Speed Mode (FCS) set to 250 rpm. If the Outdoor Fan Select Switch is in the OFF position, the outdoor fans will run in the Minimum Fan Speed Mode (MIN) set to 160 rpm regardless of the cooling demand.

LC Size 08 through 12 units have a SPDT Low Ambient Switch wired to the OF terminal and the Outdoor Fan Relay (see Fig. 57). The jumper across the PS terminal will be removed. When the LAS is active, the switch will close making contact to the OF terminal and will drop connection to the ODF Relay. When electrical connection is removed from the ODF Relay, the PS connection will be opened. This will place the third outdoor fan electrically isolated from receiving any speed command, which will then turn the motor off. This is done for units that only require two outdoor fans to run at the same factory pre-set Low Ambient Speed.

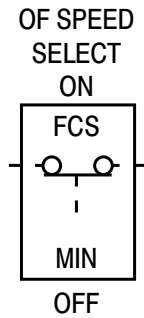

Fig. 56 — Outdoor Fan Speed Select Switch

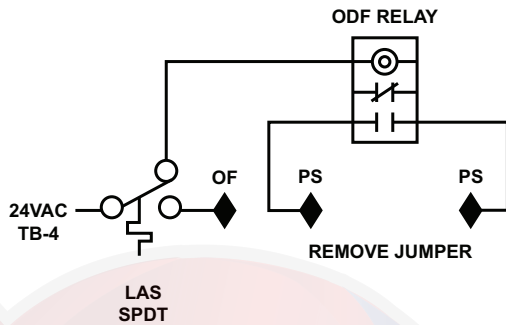

Fig. 57 — Schematic of SPDT Low Ambient Switch

Table 9 shows the operation of the outdoor fan for size 08, 09 and 12 units.

Table 9 — Low Ambient Temperature Outdoor Fan Control

48LC SIZE	NO. OF FANS ON	NO. OF FANS OFF	SWITCH	OUTDOOR FAN SELECT SWITCH	RPM
08	2	1	(1) SPDT	Down	160
09	2	1	(1) SPDT	Down	160
12	2	1	(1) SPDT	Down	160

Heating

In the Heating Mode (W1 and G on the thermostat), the ISC board sends power to W on the IGC board. Assuming the unit is controlled through a room thermostat set for fan auto, the indoor fan motor will energize and the outdoor-air dampers will open to their minimum position. The ISC board upon seeing W1 and G ON will turn the indoor fan to high speed.

The IGC board starts its gas ignition process. A check is made to ensure that the rollout switch and limit switch are closed. If the check was successful, the induced draft motor is energized, and when its speed is satisfactory, as proven by the flue gas pressure switch, the ignition activation period begins. The burners will ignite within 5 seconds. If the burners do not light, there is a 22-second delay before another 5-second attempt. This sequence is repeated for 15 minutes or until the burners light. If, after the 15 minutes, the burners still have not lit, heating is locked out. To reset the control, break 24 vac power to the thermostat.

When gas ignition occurs, the IGC board will continue to monitor the condition of the rollout switch, the limit switches, the flue gas pressure switch, as well as the flame sensor.

When W1 is turned OFF, the IGC board turns off the gas valve. The IGC board has a delay time before it turns IFO=OFF. At this time, the ISC board sees W1=OFF and IFO=ON. The ISC will keep the indoor fan ON high speed. Once the IGC board delay times out, the ISC board will see W1=OFF and IFO=OFF, which then turns the indoor fan OFF.

If the call for W1 lasted less than 1 minute, the heating cycle will not terminate until 1 minute after W1 became active. If the unit is controlled through a room thermostat set for fan auto, the indoor

fan motor will continue to operate for an additional 45 seconds then stop. If the over temperature limit opens after the indoor motor is stopped, but within 10 minutes of W1 becoming inactive, on the next cycle the time will be extended by 15 seconds. The maximum delay is 3 minutes. Once modified, the fan OFF delay will not change back to 45 seconds unless power is reset to the control. A LED indicator is provided on the IGC to monitor operation.

When additional heat is required, W2 closes and initiates power to the second stage of the main gas valve. When the thermostat is satisfied, the gas valve closes, interrupting the flow of gas to the main burners.

EconoMiSer® X (Factory Option)

The EconoMiSer X system is an expandable economizer control system, which includes a W7220 economizer module (controller) with an LCD and keypad (see Fig. 58). The W7220 can be configured with optional sensors.



Fig. 58 — W7220 Economizer Module

The W7220 economizer module can be used as a stand-alone economizer module wired directly to a commercial set-back space thermostat and sensors to provide outside air dry-bulb economizer control.

The W7220 economizer module can be connected to optional sensors for single or differential enthalpy control. The W7220 economizer module provides power and communications for the sensors.

The W7220 economizer module automatically detects sensors by polling to determine which sensors are present. If a sensor loses communications after it has been detected, the W7220 economizer controller indicates a device fail error on its LCD.

SYSTEM COMPONENTS

The EconoMiSer X system includes an economizer module, 20k mixed air sensor, damper actuator, and either a 20k outdoor air temperature sensor or S-Bus enthalpy sensors.

Economizer Module

The module is the core of the EconoMiSer X system. The module is mounted in the unit's control box, and includes the user interface for the system. The W7220 economizer module provides the basic inputs and outputs to provide simple economizer control. When used with the optional sensors, the economizer module provides more advanced economizer functionality.

S-Bus Enthalpy Control Sensors

The sensor is a combination temperature and humidity sensor which is powered by and communicates on the S-Bus. Up to three sensors may be configured with the W7220 economizer module.

CO₂ Sensor (optional)

The CO₂ sensor can be added for Demand Controlled Ventilation (DCV).

SPECIFICATIONS

W7220 Economizer Module

The module is designed for use with 2 to 10 vdc or bus communicating actuator. The module includes terminals for CO₂ sensor, Mixed Air sensor, and an Outdoor Dry Bulb sensor. Enthalpy and other options are available with bus sensors.

User Interface

Provides status for normal operation, setup parameters, checkout tests, and alarm and error conditions with a 2-line 16 character LCD display and four button keypad.

Electrical

- Rated Voltage — 20 to 30 vac RMS, 50/60 Hz
- Transformer — 100 va maximum system input
- Nominal Power Consumption (at 24 vac, 60 Hz) — 11.5 VA without sensors or actuators
- Relay Digital Output Rating at 30 vac (maximum power from Class 2 input only) — 1.5A run: 3.5A inrush at 0.45PF (200,000 cycles) or 7.5A inrush at 0.45PF (100,000 cycles)
- External Sensors Power Output — 21 vdc ± 5% at 48mA

IMPORTANT: All inputs and outputs must be Class 2 wiring.

INPUTS

Sensors

NOTE: A Mixed Air (MA) analog sensor is required on all W7220 units; either an Outdoor Air (OA) sensor for dry bulb change over or an OA bus sensor for outdoor enthalpy change over is required in addition to the MA sensor. An additional Return Air (RA) bus sensor can be added to the system for differential enthalpy or dry bulb changeover. For differential dry bulb changeover, a 20k ohm sensor is required in the OA and a bus sensor in the RA. DIP switch on RA bus sensor must be set in the RA position.

Dry Bulb Temperature (optional) and Mixed Air (required). 20k NTC

2-wire (18 to 22 AWG);

Temperature range -40°F to 150°F (-40°C to 66°C)

Temperature accuracy: 0°F/+2°F

Temperature and Humidity, C7400S1000 (optional)

S-Bus; 2-wire (18 to 22 AWG)

Temperature: range -40°F to 150°F (-40°C to 65°C)

Temperature accuracy: 0°F/+2°F

Humidity: range 0 to 100% RH with 5% accuracy.

NOTE: Up to three (3) S-Bus sensors may be connected to the W7220 economizer module for outdoor air (OA), return air (RA) and discharge (supply) air (DA).

4 Binary Inputs

1-wire 24 vac + common GND (see page 36 for wiring details).

24 vac power supply

20 to 30 vac 50/60Hz; 100 VA Class 2 transformer.

OUTPUTS

Actuator Signal

2 to 10 vdc; minimum actuator impedance is 2k ohm; bus two-wire output for bus communicating actuators.

Exhaust fan, Y1, Y2 and AUX1 O

All Relay Outputs (at 30 vac):

Running: 1.5A maximum

Inrush: 7.5A maximum

ENVIRONMENTAL

Operating Temperature

-40°F to 150°F (-40°C to 65°C).

Exception of display operation down to -4°F (-20°C) with full recovery at -4°F (-20°C) from exposure to -40°F (-40°C)

Storage Temperature

-40°F to 150°F (-40°C to 65°C)

Shipping Temperature

-40°F to 150°F (-40°C to 65°C)

Relative Humidity

5% to 95% RH non-condensing

ECONOMIZER MODULE WIRING DETAILS

Use Fig. 59 and Tables 10 and 11 to locate the wiring terminals for the Economizer module.

NOTE: The four terminal blocks are removable. Slide out each terminal block, wire it, and then slide it back into place.

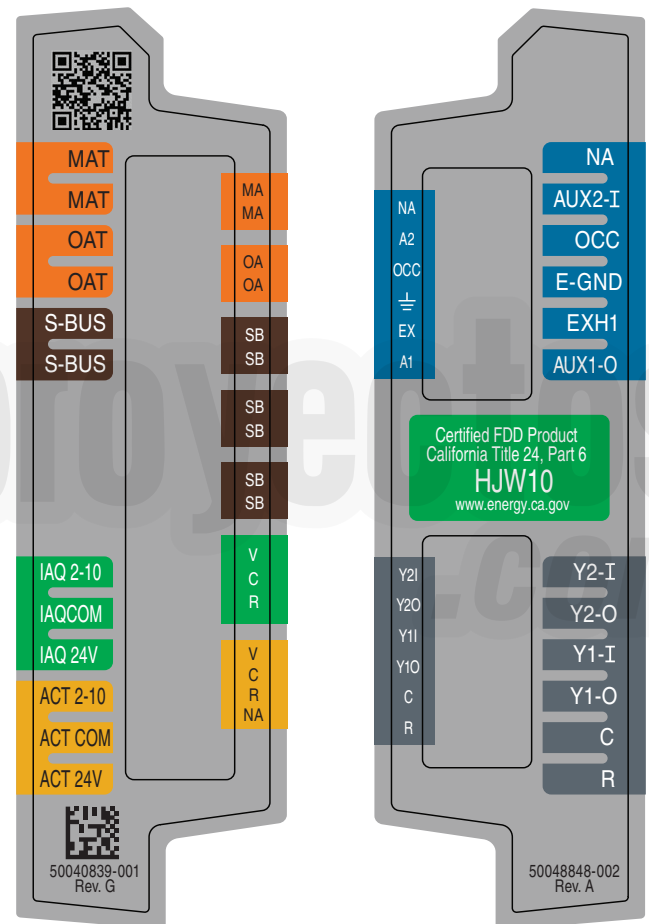

Fig. 59 — W7220 Wiring Terminals

**Table 10 — Economizer Module
(Left Hand Terminal Blocks)**

LABEL	TYPE	DESCRIPTION
Top Left Terminal Block		
MAT MAT	20k NTC and COM	Mixed Air Temperature Sensor (Polarity Insensitive Connection)
OAT OAT	20k NTC and COM	Outdoor Air Temperature Sensor (Polarity Insensitive Connection)
S-BUS S-BUS	S-BUS (Sylk Bus)	Enthalpy Control Sensor (Polarity Insensitive Connection)
Bottom Left Terminal Block		
IAQ 2-10	2-10 vdc	Air Quality Sensor Input (e.g. CO ₂ sensor)
IAQ COM	COM	Air Quality Sensor Common
IAQ 24V	24 vac	Air Quality Sensor 24 vac Source
ACT 2-10	2-10 vdc	Damper Actuator Output (2-10 vdc)
ACT COM	COM	Damper Actuator Output Common
ACT 24v	24 vac	Damper Actuator 24 vac Source

*Sylk is a trademark of Honeywell International Inc.

**Table 11 — Economizer Module
(Right Hand Terminal Blocks)**

LABEL	TYPE	DESCRIPTION
Top Right Terminal Blocks		
AUX2 I	24 vac IN	The first terminal is not used.
OCC	24 vac IN	Shut Down (SD) or HEAT (W) Conventional only and Heat Pump Changeover (O-B) in Heat Pump mode.
E-GND	E-GND	Occupied/Unoccupied Input
EXH1	24 vac OUT	Exhaust Fan 1 Output
AUX1 O	24 vac OUT	Programmable: Exhaust fan 2 output or ERV or System alarm output
Bottom Right Terminal Blocks		
Y2-I	24 vac IN	Y2 in - Cooling Stage 2 Input from space thermostat
Y2-O	24 vac OUT	Y2 out - Cooling Stage 2 Output to stage 2 mechanical cooling
Y1-I	24 vac IN	Y1 in - Cooling Stage 2 Input from space thermostat
Y1-O	24 vac OUT	Y1 out - Cooling Stage 2 Output to stage 2 mechanical cooling
C	COM	24 vac Common
R	24 vac	24 vac Power (hot)

S-Bus Sensor Wiring

The labels on the sensors and controller are color coded for ease of installation. Orange labeled sensors can only be wired to orange terminals on the controller. Brown labeled sensors can only be wired to S-bus (brown) terminals. Use Fig. 60 and Table 12 to locate the wiring terminals for each S-Bus and enthalpy control sensor.

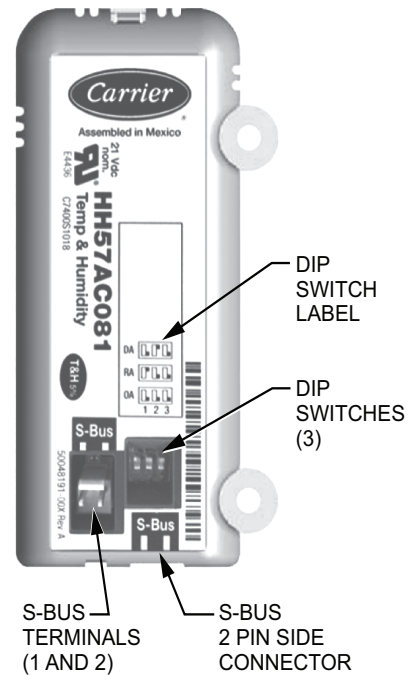

Fig. 60 — S-Bus Sensor DIP Switches

Table 12 — HH57AC081 Sensor Wiring Terminations

TERMINAL		TYPE	DESCRIPTION
NUMBER	LABEL		
1	S-BUS	S-BUS	S-BUS Communications (Enthalpy Control Sensor Bus)
2	S-BUS	S-BUS	S-BUS Communications (Enthalpy Control Sensor Bus)

Use Fig. 60 and Table 13 to set the DIP switches for the desired use of the sensor.

Table 13 — HH57AC081 Sensor DIP Switch

USE	DIP SWITCH POSITIONS FOR SWITCHES 1, 2, AND 3		
	1	2	3
DA	OFF	ON	OFF
RA	ON	OFF	OFF
OA	OFF	OFF	OFF

NOTE: When an S-Bus sensor is connected to an existing network, it will take 60 minutes for the network to recognize and auto-configure itself to use the new sensor.

During the 60-minute setup period, no alarms for sensor failures (except SAT) will be issued and no economizing function will be available.

CO₂ Sensor Wiring

When using a CO₂ sensor, the black and brown common wires are internally connected and only one is connected to “IAQ COM” on the W7220. Use the power from the W7220 to power the CO₂ sensor OR make sure the ground for the power supplies are common. See Fig. 61 for CO₂ sensor wiring.

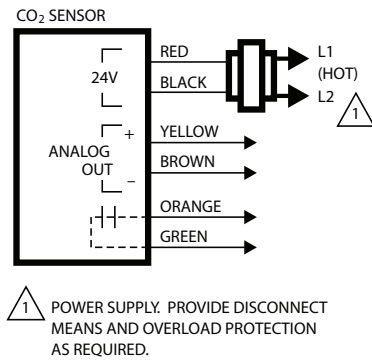

Fig. 61 — CO₂ Sensor Wiring

INTERFACE OVERVIEW

This section describes how to use the EconoMiSer[®] X user interface for:

- Keypad and menu navigation
- Settings and parameter changes
- Menu structure and selection

User Interface

The user interface consists of a 2-line LCD display and a 4-button keypad on the front of the economizer controller.

Keypad

Use the four navigation buttons (see Fig. 62) to scroll through the menus and menu items, select menu items, and to change parameter and configuration settings.

To use the keypad when working with menus:

- Press the ▲ (Up arrow) button to move to the previous menu.
- Press the ▼ (Down arrow) button to move to the next menu.
- Press the ↵ (Enter) button to display the first item in the currently displayed menu.
- Press the ⏴ (Menu Up/Exit) button to exit a menu's item and return to the list of menus.

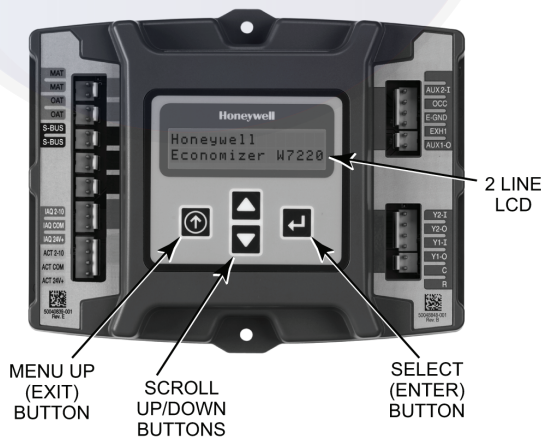

Fig. 62 — W7220 Controller Navigation Buttons

To use the keypad when working with Setpoints, System and Advanced Settings, Checkout tests and Alarms:

1. Navigate to the desired menu.
2. Press the ↵ (Enter) button to display the first item in the currently displayed menu.
3. Use the ▲ and ▼ buttons to scroll to the desired parameter.

4. Press the ↵ (Enter) button to display the value of the currently displayed item.
5. Press the ▲ button to increase (change) the displayed parameter value.
6. Press the ▼ button to decrease (change) the displayed parameter value.

NOTE: When values are displayed, pressing and holding the ▲ or ▼ button causes the display to automatically increment or decrement.

1. Press the ↵ (Enter) button to accept the displayed value and store it in nonvolatile RAM. "CHANGE STORED" displays.
2. Press the ↵ (Enter) button to return to the current menu parameter.
3. Press the ⏴ (Menu Up/Exit) button to return to the previous menu.

Menu Structure

Table 14 illustrates the complete hierarchy of menus and parameters for the EconoMiSer[®] X system.

The Menus in display order are:

- STATUS
- SETPOINTS
- SYSTEM SETUP
- ADVANCED SETUP
- CHECKOUT
- ALARMS

NOTE: Some parameters in the menus use the letters MA or MAT, indicating a mixed air temperature sensor location before the cooling coil. This unit application has the control sensor located after the cooling coil, in the fan section, where it is designated as (Cooling) Supply Air Temperature or SAT sensor.

SETUP AND CONFIGURATION

Before being placed into service, the W7220 Economizer module must be set up and configured for the installed system.

IMPORTANT: During setup, the economizer module is live at all times.

The setup process uses a hierarchical menu structure that is easy to use. Press the ▲ and ▼ arrow buttons to move forward and backward through the menus and press the button to select and confirm setup item changes.

Time-Out and Screensaver

When no buttons have been pressed for 10 minutes, the LCD displays a screen saver, which cycles through the Status items. Each Status items displays in turn and cycles to the next item after 5 seconds.

Table 14 — W7220 Menu Structure*

MENU	PARAMETER	PARAMETER DEFAULT VALUE	PARAMETER RANGE AND INCREMENT†	EXPANDED PARAMETER NAME Notes
STATUS	ECON AVAIL	NO	YES/NO	FIRST STAGE COOLING DEMAND (Y1-IN) YES = economizing available; the system can use outside air for free cooling when required
	ECONOMIZING	NO	YES/NO	FIRST STAGE COOLING RELAY OUTPUT YES = outside air being used for first stage cooling
	OCCUPIED	NO	YES/NO	OCCUPIED YES = OCC signal received from space thermostat or unitary controller YES = 24 vac on terminal OCC NO = 0 vac on terminal OCC
	HEAT PUMP	N/A**	COOL HEAT	HEAT PUMP MODE Displays COOL or HEAT when system is set to heat pump (Non-conventional)
	COOL Y1—IN	OFF	ON/OFF	FIRST STAGE COOLING DEMAND (Y1-IN) Y1-I signal from space thermostat or unitary controller for cooling stage 1. ON = 24 vac on terminal Y1-I OFF = 0 vac on terminal Y1-I
	COOL Y1—OUT	OFF	ON/OFF	FIRST STAGE COOLING RELAY OUTPUT Cool stage 1 Relay Output to stage 1 mechanical cooling (Y1—OUT terminal)
	COOL Y2—IN	OFF	ON/OFF	SECOND STAGE COOLING DEMAND (Y2-IN) Y2-I signal from space thermostat or unitary controller for second stage cooling. ON = 24 vac on terminal Y2-I OFF = 0 vac on terminal Y2-I
	COOL Y2—OUT	OFF	ON/OFF	SECOND STAGE COOLING RELAY OUTPUT Cool Stage 2 Relay Output to mechanical cooling (Y2—OUT terminal)
	MA TEMP	____ °F (or ____ °C)	-40°F to 150°F (-40°C to 66°C)	SUPPLY AIR TEMPERATURE, Cooling Mode Displays value of measured mixed air from MAT sensor. Displays ____ °F if not connected, short or out of range.
	DA TEMP	____ °F (or ____ °C)	-40°F to 150°F (-40°C to 66°C)	DISCHARGE AIR TEMPERATURE, after Heating section Displays when Discharge Air Sylk Bus sensor is connected and displays measured discharge temperature. Displays ____ °F if sensor sends invalid value, if not connected, short or out of range.
	OA TEMP	____ °F (or ____ °C)	-40°F to 140°F (-40°C to 60°C)	OUTSIDE AIR TEMP Displays measured value of outdoor air temperature. Displays ____ °F if sensor sends invalid value, short or out of range.
	OA HUM	__ %	0 to 100%	OUTSIDE AIR RELATIVE HUMIDITY Displays measured value of outdoor humidity from OA Sylk Bus sensor. Displays __ % if not connected short, or out of range.
	RA TEMP	____ °F (or ____ °C)	0°F to 140°F (-18°C to 60°C)	RETURN AIR TEMPERATURE Displays measured value of return air temperature from RAT Sylk Bus sensor. Displays ____ °F if sensor sends invalid value, if not connected, short or out of range
	RA HUM	__ %	0 to 100%	RETURN AIR RELATIVE HUMIDITY Displays measured value of return air humidity from RA Sylk Bus sensor. Displays __ % if sensor sends invalid value, if not connected, short or out of range
	IN CO2	____ ppm	0 to 2000 ppm	SPACE/RETURN AIR CO ₂ Displays value of measured CO ₂ from CO ₂ sensor. Invalid if not connected, short or out of range. May be adjusted in Advanced menu by Zero offset and Span.
	DCV STATUS	N/A	ON/OFF	DEMAND CONTROLLED VENTILATION STATUS Displays ON if above set point and OFF if below set point, and ONLY if a CO ₂ sensor is connected.
	DAMPER OUT	2.0v	2.0 to 10.0v	Displays voltage output to the damper actuator.***
	ACT POS	N/A	0 to 100%	Displays actual position of actuator
	ACT COUNT	N/A	1 to 65,535	Displays number of times actuator has cycled. 1 cycle equals 180 degrees of actuator movement in any direction.
	ACTUATOR	N/A	OK/Alarm (on Alarm menu)	Displays ERROR if voltage or torque is below actuator range.
EXH1 OUT	OFF	ON/OFF	EXHAUST STAGE 1 RELAY OUTPUT Displays ON when damper position reaches programmed percentage set point. Output of EXH1 terminal: ON = relay closed OFF = relay open	

Table 14 — W7220 Menu Structure* (cont)

MENU	PARAMETER	PARAMETER DEFAULT VALUE	PARAMETER RANGE AND INCREMENT†	EXPANDED PARAMETER NAME Notes
STATUS (cont)	EXH2 OUT	OFF	ON/OFF	EXHAUST STAGE 2 RELAY OUTPUT Output of AUX1 O terminal Displays ON when damper position reaches programmed percentage set point. ON = 24 vac output OFF = No output Displays only if AUX1 O = EXH2
	ERV	OFF	ON/OFF	ENERGY RECOVERY VENTILATOR Output of AUX1 O terminal; displays only if AUX1 O = ERV ON = 24 vac output OFF = No Output
	MECH COOL ON or HEAT STAGES ON	0	0, 1, or 2	Displays stage of mechanical cooling that is active. Displays the stage of heat pump heating that is active.
	FAN SPEED	N/A	LOW or HIGH	SUPPLY FAN SPEED Displays speed setting of fan on a 2-speed fan unit.
	W (HEAT IN)	N/A	ON/OFF	HEAT DEMAND STATUS Displays status of heat demand on a 2-speed fan unit.
SETPOINTS	MAT SET	53°F (12°C)	38°F to 70°F (3°C to 21°C); increment by 1 degree	SUPPLY AIR SETPOINT The economizer will modulate the OA damper to maintain the mixed air temperature at the set point
	LOW T LOCK	32°F (0°C)	-45°F to 80°F (-43°C to 27°C); increment by 1 degree	COMPRESSOR LOW TEMPERATURE LOCKOUT Set point determines outdoor temperature when the mechanical cooling cannot be turned on. Commonly referred to as the Compressor lockout. At or below the set point, the Y1-O and Y2-O will not be energized on the controller.
	DRYBLB SET	63°F (17°C)	48°F to 80°F (9°C to 27°C); increment by 1 degree	OA DRY BULB TEMPERATURE CHANGEOVER SETPOINT <i>Dry bulb set point will only appear if using dry bulb changeover.</i> Set point determines where the economizer will assume outdoor air temperature is good for free cooling; e.g.; at 63°F unit will economize at 62°F and below and not economize at 64°F and above. There is a 2°F deadband.
	ENTH CURVE	ES3	ES1,ES2,ES3,ES4, or ES5	ENTHALPY CHANGEOVER CURVE ES curve will only appear if using enthalpy changeover. Enthalpy boundary "curves" for economizing using single enthalpy. See page 46 for description of enthalpy curves.
	DCV SET	1100ppm	500 to 2000 ppm; increment by 100	DEMAND CONTROLLED VENTILATION Displays only if CO ₂ sensor is connected. Set point for Demand Controlled Ventilation of space. Above the set point, the OA dampers will modulate open to bring in additional OA to maintain a space ppm level below the set point.
	MIN POS	2.8 V	2 to 10 vdc	VENTILATION MINIMUM POSITION Displays ONLY if a CO ₂ sensor is NOT connected. With 2-speed fan units, MIN POS L (low speed fan) and MIN POS H (high speed fan) settings are required. Default for MIN POS L is 3.2V and MIN POS H is 2.8V.
	VENTMAX	2.8 V	2 to 10 vdc	DCV MAXIMUM DAMPER POSITION Displays only if a CO ₂ sensor is connected. Used for Vbz (ventilation max cfm) set point. VENTMAX is the same setting as MIN POS would be if unit did not have CO ₂ sensor.
			100 to 9990 cfm; increment by 10	If OA, MA, RA, and CO ₂ sensors are connected and DCV CAL ENABLE is set to AUTO mode, the OA dampers are controlled by CFM and displays from 100 to 9990 CFM.
			2 to 10 vdc	With 2-speed fan units, VENTMAX L (low speed fan) and VENTMAX H (high speed fan) settings are required. Default for VENTMAX L is 3.2V and VENTMAX H is 2.8V
	VENTMIN	2.25 V	2 to 10 vdc or 100 to 9990 cfm increment by 10	DCV MINIMUM DAMPER POSITION Displays only if a CO ₂ sensor is connected. Used for Va (ventilation min cfm) set point. This is the ventilation for less than maximum occupancy of the space.
100 to 9990 cfm; increment by 10			If OA, MA, RA, and CO ₂ sensors are connected and DCV CAL ENABLE is set to AUTO mode, the OA dampers are controlled by CFM and displays from 100 to 9990 CFM.	
2 to 10 vdc			With 2-speed fan units VENTMIN L (low speed fan) and VENTMIN H (high speed fan) settings are required. Default for VENTMIN L is 2.5V and VENTMIN H is 2.25V	
ERV OAT SP††	32°F (0°C)	0°F to 50°F (-18°C to 10°C); increment by 1 degree	ENERGY RECOVERY VENTILATOR UNIT OUTDOOR AIR TEMPERATURE SETPOINT Only when AUX1 O = ERV	

Table 14 — W7220 Menu Structure* (cont)

MENU	PARAMETER	PARAMETER DEFAULT VALUE	PARAMETER RANGE AND INCREMENT†	EXPANDED PARAMETER NAME Notes
SETPOINTS (cont)	EXH1 SET	50%	0 to 100%; increment by 1	EXHAUST FAN STAGE 1 SETPOINT Set point for OA damper position when exhaust fan 1 is powered by the economizer. With 2-speed fan units, Exh1 L (low speed fan) and Exh1 H (high speed fan) settings are required. Default for Exh1 L is 65% and Exh1 H is 50%
	EXH2 SET	75%	0 to 100%; increment by 1	EXHAUST FAN STAGE 2 SETPOINT Set point for OA damper position when exhaust fan 2 is powered by the economizer. Only used when AUX1 O is set to EHX2. With 2-speed fan units, Exh2 L (low speed fan) and Exh2 H (high speed fan) settings are required. Default for Exh2 L is 80% and Exh2 H is 75%
SYSTEM SETUP	INSTALL	01/01/10	N/A	Display order = MM/DD/YY Setting order = DD, MM, then YY.
	UNITS DEG	°F	°F or °C	Sets economizer controller in degrees Fahrenheit or Celsius
	EQUIPMENT	CONV	CONV or HP	CONV = conventional; HP O/B = Enable Heat Pump mode. Use AUX2 I for Heat Pump input from thermostat or controller.
	AUX2 IN	W	Shutdown (SD) Heat (W1) HP(O) HP(B)	In CONV mode: SD = Enables configuration of shutdown (default); W = Informs controller that system is in heating mode. NOTE: If using 2-speed fan mode, you must program CONV mode for W. Shutdown is not available in 2-speed fan mode. In HP O/B mode: HP(O) = energize heat pump on Cool (default); HP(B) = energize heat pump on heat.
	FAN SPEED	2 speed	1 speed/2 speed	Sets the economizer controller for operation of 1 speed or 2 speed supply fan. The controller does not control the fan, but positions the OA and RA dampers to heating or cooling mode. NOTE: 2-speed fan option also needs Heat (W1) programmed in AUX 2 In.
	FAN CFM	5000 cfm	100 to 15000 cfm; increment by 100	UNIT DESIGN AIRFLOW (CFM) Enter only if using DCVCL ENA = AUTO This is the capacity of the RTU. The value is found on the nameplate label for the specific unit.
	AUX1 OUT	NONE	NONE ERV EXH2 SYS	Select OUTPUT for AUX1 O relay • NONE = not configured (output is not used) • ERV = Energy Recovery Ventilator†† • EXH2 = second damper position 24 vac out for second exhaust fan • SYS = use output as an alarm signal
	OCC	INPUT	INPUT or ALWAYS	OCCUPIED MODE BY EXTERNAL SIGNAL When using a setback thermostat with occupancy out (24 vac), the 24 vac is input "INPUT" to the OCC terminal. If no occupancy output from the thermostat, then change program to "ALWAYS" OR add a jumper from terminal R to OCC terminal.
	FACTORY DEFAULT	NO	NO or YES	Resets all set points to factory defaults when set to YES. LCD will briefly flash YES and change to NO but all parameters will change to the factory default values.
ADVANCED SETUP	MA LO SET	45°F (7°C)	35°F to 65°F (2°C to 18°C); Increment by 1 degree	SUPPLY AIR TEMPERATURE LOW LIMIT Temperature to activate Freeze Protection (close damper or modulate to MIN POS if temp falls below set value).
	FREEZE POS	CLO	CLO or MIN	FREEZE PROTECTION DAMPER POSITION Damper position when freeze protection is active (closed or MIN POS).
	CO2 ZERO	0ppm	0 to 500 ppm; Increment by 10	CO ₂ ppm level to match CO ₂ sensor start level.
	CO2 SPAN	2000ppm	1000 to 3000 ppm; Increment by 50	CO ₂ ppm span to match CO ₂ sensor; e.g.: 500-1500 sensor output would be 500 CO ₂ zero and 1000 CO ₂ span.
	STG3 DLY	2.0h	0 min, 5 min, 15 min, then 15 min intervals. Up to 4 hrs or OFF	COOLING STAGE 3 DELAY Delay after stage 2 cool has been active. Turns on second stage of cooling when economizer is first stage call and mechanical cooling is second stage call. Allows three stages of cooling, 1 economizer and 2 mechanical. OFF = no Stage 3 cooling
	SD DMPR POS	CLO	CLO or OPN	Indicates shutdown signal from space thermostat or unitary controller. When controller receives 24 vac input on the SD terminal in conventional mode, the OA damper will open if programmed for OPN and OA damper will close if programmed for CLO. All other controls, e.g., fans, etc. will shut off.
	DA LO ALM	45°F (7°C)	NONE 35°F to 65°F (2°C to 18°C); Increment by 5°F	Used for alarm for when the DA air temperature is too low. Set lower range of alarm, below this temperature the alarm will show on the display.

Table 14 — W7220 Menu Structure* (cont)

MENU	PARAMETER	PARAMETER DEFAULT VALUE	PARAMETER RANGE AND INCREMENT†	EXPANDED PARAMETER NAME Notes
ADVANCED SETUP (cont)	DA HI ALM	80°F (27°C)	NONE 70°F to 180°F (21°C to 82°C); Increment by 5°F	Used for alarm for when the DA air temperature is too high. Sets upper range of alarm; above this temperature, the alarm will show on the display.
	DCVCAL ENA	MAN	MAN (manual) AUTO	Turns on the DCV automatic control of the dampers. Resets ventilation based on the RA, OA, and MA sensor conditions. Requires all (RA, OA, MA, CO ₂) sensors. This operation is not operable with a 2-speed fan unit.
	MAT T CAL	0.0°F	± 2.5°F	SUPPLY AIR TEMPERATURE CALIBRATION Allows for the operator to adjust for an out of calibration temperature sensor.
	OAS T CAL	0.0°F	± 2.5°F	OUTSIDE AIR TEMPERATURE CALIBRATION Allows for the operator to adjust for an out of calibration temperature sensor.
	OA H CAL	0% RH	±10% RH	OUTSIDE AIR HUMIDITY CALIBRATION Allows for operator to adjust for an out of calibration humidity sensor.
	RA T CAL	0.0°F	± 2.5°F	RETURN AIR TEMPERATURE CALIBRATION Allows for the operator to adjust for an out of calibration temperature sensor.
	RA H CAL	0% RH	±10% RH	RETURN AIR HUMIDITY CALIBRATION Allows for operator to adjust for an out of calibration humidity sensor.
	DA T CAL	0.0°F	± 2.5°F	DISCHARGE AIR TEMPERATURE CALIBRATION Allows for the operator to adjust for an out of calibration temperature sensor.
	2SP FAN DELAY	5 Minutes	0 to 20 minutes in 1 minute increments	TIME DELAY ON SECOND STAGE ECONOMIZING When in economizing mode, this is the delay for the high speed fan to try to satisfy the call for second stage cooling before the first stage mechanical cooling is enabled.
CHECKOUT***	DAMPER MINIMUM POSITION	N/A	N/A	The checkout for the damper minimum position is based on the system. See Table 15.
	DAMPER OPEN	N/A	N/A	Position damper to the full open position. Exhaust fan contacts enable during the DAMPER OPEN test. Make sure to pause in the mode to allow exhaust contacts to energize due to the delay in the system.
	DAMPER CLOSE	N/A	N/A	Positions damper to the fully closed position
	CONNECT Y1-O	N/A	N/A	Closes the Y1-O relay (Y1-O)
	CONNECT Y2-O	N/A	N/A	Closes the Y2-O relay (Y2-O)
	CONNECT AUX1-O	N/A	N/A	Energizes the AUX output. If Aux setting is: • NONE — no action taken • ERV — 24 vac out. Turns on or signals an ERV that the conditions are not good for economizing but are for ERV operation.†† • SYS — 24 vac out. Issues a system alarm
CONNECT EXH1	N/A	N/A	Closes the power exhaust fan 1 relay (EXH1)	
ALARMS	Alarms display only when they are active. The menu title "ALARMS(#)" includes the number of active alarms in parenthesis (). When using SYLK bus sensors, "SYLK" will appear on the screen, and when using 20k OA temperature sensors, "SENS T" will appear on the screen			
	MA T SENS ERR	N/A	N/A	SUPPLY AIR TEMPERATURE SENSOR ERROR Mixed air sensor has failed or become disconnected - check wiring, then replace sensor if the alarm continues.
	CO2 SENS ERR	N/A	N/A	CO ₂ SENSOR ERROR CO ₂ sensor has failed, gone out of range or become disconnected - check wiring then replace sensor if the alarm continues.
	OA SYLK T ERR	N/A	N/A	OUTSIDE AIR S-BUS SENSOR ERROR
	OA SYLK H ERR	N/A	N/A	Outdoor air enthalpy sensor has failed or become disconnected - check wiring, then replace sensor if the alarm continues.
	RA SYLK T ERR	N/A	N/A	RETURN AIR S-BUS SENSOR ERROR
	RA SYLK H ERR	N/A	N/A	Return air enthalpy sensor has failed or become disconnected - check wiring, then replace sensor if the alarm continues.
	DA SYLK T ERR	N/A	N/A	DISCHARGE AIR S-BUS SENSOR ERROR Discharge air sensor has failed or become disconnected - check wiring, then replace sensor if the alarm continues.
	OA SENS T ERR	N/A	N/A	OUTSIDE AIR TEMPERATURE SENSOR ERROR Outdoor air temperature sensor has failed or become disconnected - check wiring, then replace if the alarm continues.
ACT ERROR	N/A	N/A	ACTUATOR ERROR Actuator has failed or become disconnected - check for stall, over voltage, under voltage and actuator count. Replace actuator if damper is movable and supply voltage is between 21.6 V and 26.4 V. Check actuator count on STATUS menu.	

Table 14 — W7220 Menu Structure* (cont)

MENU	PARAMETER	PARAMETER DEFAULT VALUE	PARAMETER RANGE AND INCREMENT†	EXPANDED PARAMETER NAME Notes
ALARMS (CONT)	FREEZE ALARM	N/A	N/A	Check if outdoor temperature is below the LOW Temp Lockout on set point menu. Check if Mixed air temperature on STATUS menu is below the Lo Set point on Advanced menu. When conditions are back in normal range, the alarm will go away.
	SHUTDOWN ACTIVE	N/A	N/A	AUX2 IN is programmed for SHUTDOWN and 24 V has been applied to AUX2 IN terminal.
	DMP CAL RUNNING	N/A	N/A	DAMPER CALIBRATION ROUTINE RUNNING If DCV Auto enable has been programmed, this alarm will display when the W7220 is completing a calibration on the dampers. Wait until the calibration is completed and the alarm will go away. Must have OA, MA and RA sensors for DCV calibration; set up is in the Advanced setup menu.
	DA SENS ALM	N/A	N/A	DISCHARGE AIR TEMPERATURE SENSOR ALARM Discharge air temperature is out of the range set in the ADVANCED SETUP Menu. Check the temperature of the discharge air.
	SYS ALARM	N/A	N/A	When AUX1-O is set to SYS and there is any alarm (e.g., failed sensors, etc.), the AUX1-O terminal has 24 vac out.
	ACT UNDER V	N/A	N/A	ACTUATOR VOLTAGE LOW Voltage received by actuator is above expected range.
	ACT OVER V	N/A	N/A	ACTUATOR VOLTAGE HIGH Voltage received by actuator is below expected range.
	ACT STALLED	N/A	N/A	ACTUATOR STALLED Actuator stopped before achieving commanded position.

LEGEND

- CLO** — Compressor Lockout
- ERV** — Energy Recovery Ventilator
- LCD** — Liquid Crystal Display
- MA** — Mixed Air
- MAT** — Mixed Air Temperature
- N/A** — Not Applicable
- OA** — Outdoor Air
- OAT** — Outdoor Air Temperature
- OCC** — Occupied
- RA** — Return Air
- RAT** — Return Air Temperature
- RTU** — Rooftop Unit
- SYS** — System

NOTES:

1. STATUS → OCCUPIED — The factory-standard Occupancy signal originates with a thermostat or other controller call for indoor fan operation at CTB terminal G. This signal passes through the Central Terminal Board's OCCUPANCY jumper to the ECONO connector and to the W7220's OCC input terminal. An external timeclock or relay is required to implement an Occupancy schedule on the economizer damper position.
2. STATUS → MA TEMP, SETPOINTS → MAT SET — The W7220 menu parameters and labels include designations MA, MAT and Mixed Air for the economizer cooling control sensor. On these rooftop units, the economizer control sensor is located downstream of the evaporator/indoor coil in the supply fan section where this sensor is designated as Supply Air Temperature (SAT) sensor.
3. SETPOINTS → DRYBLB SET — This point is not displayed if a Return Air (differential) temperature sensor or an Outdoor Air enthalpy sensor is connected.
4. SYSTEM SETUP parameters must be configured as noted for 2-Speed unit operation:
EQUIPMENT = CONV
AUX2 I = W
FAN SPEED = 2SPEED

* Table 14 illustrates the complete hierarchy. Your menu parameters may be different depending on your configuration. For example, if you do not have a DCV (CO₂) sensor, then none of the DCV parameters appear.

† When values are displayed, pressing and holding the ▲ or ▼ button causes the display to automatically increment.

** N/A = Not Applicable.

†† ERV Operation: When in cooling mode AND the conditions are NOT OK for economizing - the ERV terminal will be energized. In the Heating mode, the ERV terminal will be energized when the OA is below the ERV OAT set point in the set point menu.

*** After 10 minutes without a command or mode change, the controller will change to normal operation.

For damper minimum position settings and checkout menu readings, see Table 15. For dry bulb operation with a 1-speed indoor fan, see Tables 16 and 17. For enthalpy operation with a 1-speed fan, see Tables 18 and 19. For dry bulb operation with a 2-speed indoor fan, with or without DCV, see Tables 20 and 21. For enthalpy operation with a 2-speed indoor fan, with or without DCV, see Tables 22 and 23.

Table 15 — Damper Minimum Position Settings and Readings on Checkout Menu

DEMAND CONTROLLED VENTILATION (CO ₂ SENSOR)	FAN SPEED	SETPOINTS	CHECKOUT
NO	1	MIN POS	VMAX-HS
		N/A	N/A
	2	MIN POS H	VMAX-HS
		MIN POS L	VMAX-LS
YES	1	VENT MIN	VMAX-HS
		VENT MAX	VMAX-HS
		VENT MIN H	VMAX-HS
	2	VENT MAX H	VMAX-LS
		VENT MIN L	N/A
		VENT MAX L	N/A

Table 16 — Dry Bulb Operation without DCV (CO₂ Sensor) — 1 Speed Fan

DEMAND CONTROLLED VENTILATION (DCV)	OUTSIDE AIR GOOD TO ECONOMIZE	Y1-I	Y2-I	FAN SPEED	Y1-O	Y2-O	OCCUPIED	UNOCCUPIED
NONE	No	Off	Off	High	0-v/Off	0-v/Off	MIN POS	Closed
		On	Off	High	24-v/On	0-v/Off	MIN POS	Closed
		On	On	High	24-v/On	24-v/On	MIN POS	Closed
	Yes	Off	Off	High	0-v/Off	0-v/Off	MIN POS	Closed
		On	Off	High	0-v/Off	0-v/Off	MIN POS to Full-Open	Closed to Full-Open
		On	On	High	24-v/On	0-v/Off*	MIN POS to Full-Open	Closed to Full-Open

*With stage 3 delay (STG3 DLY) in Advanced setup menu can turn on second stage of mechanical cooling Y2-O after the delay if the call for Y-I and Y2-I have not been satisfied.

Table 17 — Dry Bulb Operation with DCV (CO₂ Sensor) — 1 Speed Fan

DEMAND CONTROLLED VENTILATION (DCV)	OUTSIDE AIR GOOD TO ECONOMIZE	Y1-I	Y2-I	FAN SPEED	Y1-O	Y2-O	OCCUPIED	UNOCCUPIED
Below CO ₂ set	No	Off	Off	High	0-v/Off	0-v/Off	VENTMIN	Closed
		On	Off	High	24-v/On	0-v/Off	VENTMIN	Closed
		On	On	High	24-v/On	24-v/On	VENTMIN	Closed
	Yes	Off	Off	High	0-v/Off	0-v/Off	VENTMIN	Closed
		On	Off	High	0-v/Off	0-v/Off	VENTMIN to Full-Open	Closed to Full-Open
		On	On	High	24-v/On	0-v/Off*	VENTMIN to Full-Open	Closed to Full-Open
Above CO ₂ set	No	Off	Off	High	0-v/Off	0-v/Off	VENTMIN to VENTMAX	Closed
		On	Off	High	24-v/On	0-v/Off	VENTMIN to VENTMAX	Closed
		On	On	High	24-v/On	24-v/On	VENTMIN to VENTMAX	Closed
	Yes	Off	Off	High	0-v/Off	0-v/Off	VENTMIN to VENTMAX	Closed
		On	Off	High	0-v/Off	0-v/Off	VENTMIN to Full-Open	Closed to Full-Open
		On	On	High	24-v/On	0-v/Off*	VENTMIN to Full-Open	Closed to Full-Open

*With stage 3 delay (STG3 DLY) in Advanced setup menu can turn on second stage of mechanical cooling Y2-O after the delay if the call for Y-I and Y2-I have not been satisfied.

Table 18 — Enthalpy Operation without DCV (CO₂ Sensor) — 1 Speed Fan

DEMAND CONTROLLED VENTILATION (DCV)	OUTSIDE AIR GOOD TO ECONOMIZE	Y1-I	Y2-I	FAN SPEED	Y1-O	Y2-O	OCCUPIED	UNOCCUPIED
NONE	No	Off	Off	High	0-v/Off	0-v/Off	MIN POS	Closed
		On	Off	High	24-v/On	0-v/Off	MIN POS	Closed
		On	On	High	24-v/On	24-v/On	MIN POS	Closed
	Yes	Off	Off	High	0-v/Off	0-v/Off	MIN POS	Closed
		On	Off	High	0-v/Off	0-v/Off	MIN POS to Full-Open	Closed to Full-Open
		On	On	High	24-v/On	0-v/Off*	MIN POS to Full-Open	Closed to Full-Open

*With stage 3 delay (STG3 DLY) in Advanced setup menu can turn on second stage of mechanical cooling Y2-O after the delay if the call for Y-I and Y2-I have not been satisfied.

Table 19 — Enthalpy Operation with DCV (CO₂ Sensor) — 1 Speed Fan

DEMAND CONTROLLED VENTILATION (DCV)	OUTSIDE AIR GOOD TO ECONOMIZE	Y1-I	Y2-I	FAN SPEED	Y1-O	Y2-O	OCCUPIED	UNOCCUPIED
Below CO ₂ set	No	Off	Off	High	0-v/Off	0-v/Off	VENTMIN	Closed
		On	Off	High	24-v/On	0-v/Off	VENTMIN	Closed
		On	On	High	24-v/On	24-v/On	VENTMIN	Closed
	Yes	Off	Off	High	0-v/Off	0-v/Off	VENTMIN	Closed
		On	Off	High	0-v/Off	0-v/Off	VENTMIN to Full-Open	Closed to Full-Open
		On	On	High	24-v/On	0-v/Off†	VENTMIN to Full-Open	Closed to Full-Open
Above CO ₂ set	No	Off	Off	High	0-v/Off	0-v/Off	VENTMIN to VENTMAX	Closed
		On	Off	High	24-v/On	0-v/Off	VENTMIN L to VENTMAX	Closed
		On	On	High	24-v/On	24-v/On	VENTMIN H to VENTMAX	Closed
	Yes	Off	Off	High	0-v/Off	0-v/Off	VENTMIN L to VENTMAX	Closed
		On	Off	High	0-v/Off	0-v/Off	VENTMIN to Full-Open	Closed to Full-Open
		On	On	High	DELAY* 24-v/On	0-v/Off†	VENTMIN to Full-Open	Closed to Full-Open

*With 2SP FAN DELAY (Advanced Setup Menu) when in the economizing mode there is a delay for the high speed fan to try to satisfy the call for second stage cooling by turning on the fan to high and opening the OA damper 100% before the first stage mechanical cooling is enabled.

†With stage 3 delay (STG3 DLY) in Advanced setup menu can turn on second stage of mechanical cooling Y2-O after the delay if the call for Y-I and Y2-I have not been satisfied.

Table 20 — Dry Bulb Operation Without DCV (CO₂ Sensor) — 2 Speed Fan

DEMAND CONTROLLED VENTILATION (DCV)	OUTSIDE AIR GOOD TO ECONOMIZE	Y1-I	Y2-I	FAN SPEED	Y1-O	Y2-O	OCCUPIED	UNOCCUPIED
NONE	No	Off	Off	Low	0-v/Off	0-v/Off	MIN POS L	Closed
		On	Off	Low	24-v/On	0-v/Off	MIN POS L	Closed
		On	On	High	24-v/On	24-v/On	MIN POS H	Closed
NONE	Yes	Off	Off	Low	0-v/Off	0-v/Off	MIN POS L	Closed
		On	Off	Low	0-v/Off	0-v/Off	MIN POS L to Full-Open	Closed to Full-Open
		On	On	High	DELAY* 24-v/On	0-v/Off†	MIN POS H to Full-Open	Closed to Full-Open

*With 2SP FAN DELAY (Advanced Setup Menu) when in the economizing mode there is a delay for the high speed fan to try to satisfy the call for second stage cooling by turning on the fan to high and opening the OA damper 100% before the first stage mechanical cooling is enabled.

†With stage 3 delay (STG3 DLY) in Advanced setup menu can turn on second stage of mechanical cooling Y2-O after the delay if the call for Y-I and Y2-I have not been satisfied.

Table 21 — Dry Bulb Operation With DCV (CO₂ Sensor) — 2 Speed Fan

DEMAND CONTROLLED VENTILATION (DCV)	OUTSIDE AIR GOOD TO ECONOMIZE	Y1-I	Y2-I	FAN SPEED	Y1-O	Y2-O	OCCUPIED	UNOCCUPIED
Below CO ₂ Set	No	OFF	OFF	LOW	0v/Off	0v/Off	VENTMIN	Closed
		ON	OFF	LOW	24v/On	0v/Off	VENTMIN	Closed
		ON	ON	HIGH	24v/On	24v/On	VENTMIN	Closed
	Yes	OFF	OFF	LOW	0v/Off	0v/Off	VENTMIN	Closed
		ON	OFF	LOW	0v/Off	0v/Off	VENTMIN to Full-Open	Closed to Full-Open
		ON	ON	HIGH	24v/On	0v/Off	VENTMIN to Full-Open	Closed to Full-Open
Above CO ₂ Set	No	OFF	OFF	LOW	0v/Off	0v/Off	VENTMIN to VENTMAX	Closed
		ON	OFF	LOW	24v/On	0v/Off	VENTMIN to VENTMAX	Closed
		ON	ON	HIGH	24v/On	24v/On	VENTMIN to VENTMAX	Closed
	Yes	OFF	OFF	LOW	0v/Off	0v/Off	VENTMIN to VENTMAX	Closed
		ON	OFF	LOW	0v/Off	0v/Off	VENTMIN to Full-Open	Closed to Full-Open
		ON	ON	HIGH	DELAY* 24v/On	0v/Off†	VENTMIN to Full-Open	Closed to Full-Open

*With 2SP FAN DELAY (Advanced Setup Menu) when in the economizing mode there is a delay for the high speed fan to try to satisfy the call for second stage cooling by turning on the fan to high and opening the OA damper 100% before the first stage mechanical cooling is enabled.

†With stage 3 delay (STG3 DLY) in Advanced setup menu can turn on second stage of mechanical cooling Y2-O after the delay if the call for Y1-I and Y2-I have not been satisfied.

Table 22 — Enthalpy Operation Without DCV (CO₂ Sensor) — 2 Speed Fan

DEMAND CONTROLLED VENTILATION (DCV)	OUTSIDE AIR GOOD TO ECONOMIZE	Y1-I	Y2-I	FAN SPEED	Y1-O	Y2-O	OCCUPIED	UNOCCUPIED
NO CO ₂ SENSOR	NO	OFF	OFF	LOW	0v/Off	0v/Off	MIN POS	Closed
		ON	OFF	LOW	24v/On	0v/Off	MIN POS	Closed
		ON	ON	HIGH	24v/On	24v/On	MIN POS	Closed
	YES	OFF	OFF	LOW	0v/Off	0v/Off	MIN POS	Closed
		ON	OFF	LOW	0v/Off	0v/Off	MIN POS to Full Open	Closed to Full-Open
		ON	ON	HIGH	DELAY* 24v/On	0v/Off†	MIN POS to Full Open	Closed to Full-Open

*With 2SP FAN DELAY (Advanced Setup Menu) when in the economizing mode there is a delay for the high speed fan to try to satisfy the call for second stage cooling by turning on the fan to high and opening the OA damper 100% before the first stage mechanical cooling is enabled.

†With stage 3 delay (STG3 DLY) in Advanced setup menu can turn on second stage of mechanical cooling Y2-O after the delay if the call for Y1-I and Y2-I have not been satisfied.

Table 23 — Enthalpy Operation With DCV (CO₂ Sensor) — 2 Speed Fan

DEMAND CONTROLLED VENTILATION (DCV)	OUTSIDE AIR GOOD TO ECONOMIZE	Y1-I	Y2-I	FAN SPEED	Y1-O	Y2-O	OCCUPIED	UNOCCUPIED
Below CO ₂ Set	No	OFF	OFF	LOW	0v/Off	0v/Off	VENTMIN	Closed
		ON	OFF	LOW	24v/On	0v/Off	VENTMIN	Closed
		ON	ON	HIGH	24v/On	24v/On	VENTMIN	Closed
	Yes	OFF	OFF	LOW	0v/Off	0v/Off	VENTMIN	Closed
		ON	OFF	LOW	0v/Off	0v/Off	VENTMIN to Full-Open	Closed to Full-Open
		ON	ON	HIGH	24v/On	0v/Off	VENTMIN to Full-Open	Closed to Full-Open
Above CO ₂ Set	No	OFF	OFF	LOW	0v/Off	0v/Off	VENTMIN to VENTMAX	Closed
		ON	OFF	LOW	24v/On	0v/Off	VENTMIN to VENTMAX	Closed
		ON	ON	HIGH	24v/On	24v/On	VENTMIN to VENTMAX	Closed
	Yes	OFF	OFF	LOW	0v/Off	0v/Off	VENTMIN to VENTMAX	Closed
		ON	OFF	LOW	0v/Off	0v/Off	VENTMIN to Full-Open	Closed to Full-Open
		ON	ON	HIGH	DELAY* 24v/On	0v/Off*	VENTMIN to Full-Open	Closed to Full-Open

*With 2SP FAN DELAY (Advanced Setup Menu) when in the economizing mode there is a delay for the high speed fan to try to satisfy the call for second stage cooling by turning on the fan to high and opening the OA damper 100% before the first stage mechanical cooling is enabled.

†With stage 3 delay (STG3 DLY) in Advanced setup menu can turn on second stage of mechanical cooling Y2-O after the delay if the call for Y1-I and Y2-I have not been satisfied.

ENTHALPY SETTINGS

When the OA temperature, enthalpy and dew point are below the respective set points, the Outdoor Air can be used for economizing. Figure 63 shows the new single enthalpy boundaries in the W7220. There are 5 boundaries (set points ES1 through ES5), which are defined by dry bulb temperature, enthalpy and dew point.

Refer to Table 25 for ENTH CURVE set point values.

The W7220 calculates the enthalpy and dew point using the OA temperature and humidity input from the OA enthalpy sensor. When the OA temperature, OA humidity and OA dew point are all below the selected boundary, the economizer sets the economizing mode to YES, economizing is available.

When all of the OA conditions are above the selected boundary, the conditions are not good to economize and the mode is set to NO.

Figure 63 shows the 5 current boundaries. There is also a high limit boundary for differential enthalpy. The high limit boundary is ES1 when there are no stages of mechanical cooling energized and HL (high limit) when a compressor stage is energized.

TWO-SPEED FAN OPERATION

NOTE: Two-Speed Fan operation applies to size 07 models only.

The W7220 controller has the capability to work with a system using a 2-speed supply fan. The W7220 does not control the supply directly but uses the following input status to determine the speed of the supply fan and controls the OA damper to the required position, see Table 24.

Table 24 — Fan Speed

STATE	FAN SPEED
OCC	Low
Y1	Low
Y2	High
W	High

The W (heating mode) is not controlled by the W7220 but it requires the status to know where to position the OA damper for minimum position for the fan speed.

The 2-speed fan delay is available when the system is programmed for 2-speed fan (in the System Setup menu item). The 2-speed fan delay is defaulted to 5 minutes and can be changed in the Advanced Setup menu item. When the unit has a call for Y1 In and in the free cooling mode and there is a call for Y2 In, the 2-speed fan delay starts and the OA damper will modulate 100% open, the supply fan should be set to high speed by the unit controller.

After the delay one of two actions will happen:

- The Y2 In call will be satisfied with the damper 100% open and fan on high speed and the call will turn off
- OR
- If the call for additional cooling in the space has not been satisfied then the first stage of mechanical cooling will be enabled through Y1 Out or Y2 Out.

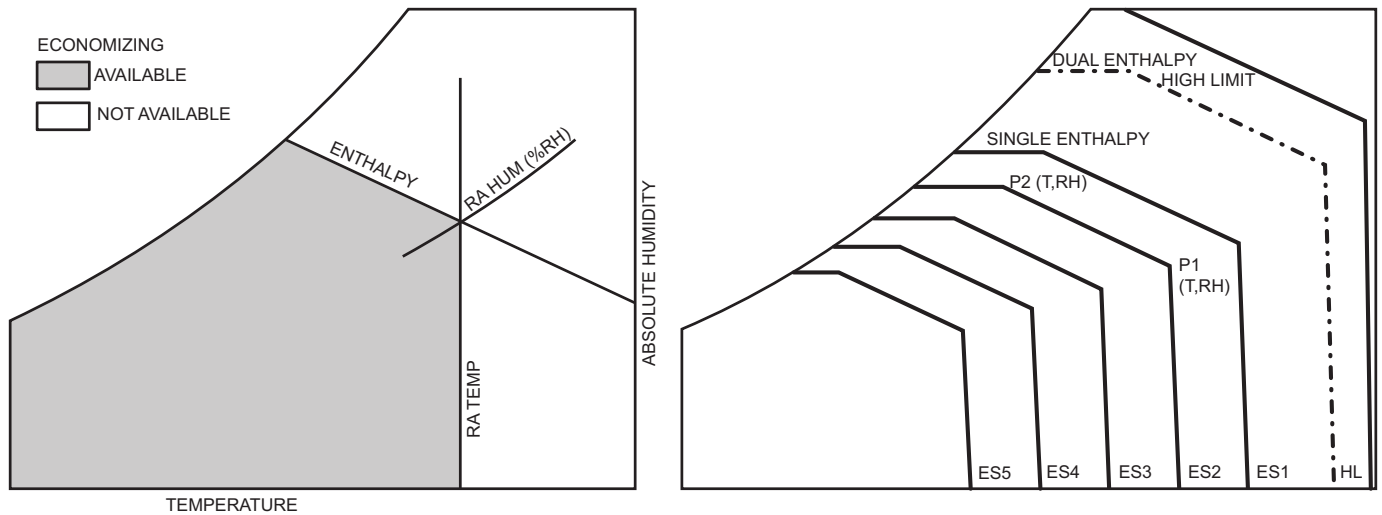

Fig. 63 — Single Enthalpy Curve Boundaries

Table 25 — Single Enthalpy and Dual Enthalpy High Limit Curves

ENTHALPY CURVE	TEMP. DRY BULB (F)	TEMP. DEWPOINT (F)	ENTHALPY (btu/lb/da)	POINT P1		POINT P2	
				TEMP. (F)	HUMIDITY (%RH)	TEMP. (F)	HUMIDITY (%RH)
ES1	80	60	28.0	80	36.8	66.3	80.1
ES2	75	57	26.0	75	39.6	63.3	80.0
ES3	70	54	24.0	70	42.3	59.7	81.4
ES4	65	51	22.0	65	44.8	55.7	84.2
ES5	60	48	20.0	60	46.9	51.3	88.5
HL	86	66	32.4	86	38.9	72.4	80.3

CHECKOUT

Inspect all wiring connections at the economizer module's terminals, and verify compliance with the installation wiring diagrams. For checkout, review the Status of each configured parameter and perform the Checkout tests.

NOTE: For information about menu navigation and use of the keypad see Interface Overview on page 37.

Power Up

After the W7220 module is mounted and wired, apply power.

Initial Menu Display

On initial start up, Honeywell displays on the first line and economizer W7220 on the second line. After a brief pause, the revision of the software appears on the first line and the second line will be blank.

Power Loss (Outage or Brownout)

All set points and advanced settings are restored after any power loss or interruption.

NOTE: All settings are stored in non-volatile flash memory.

Status

Use the Status menu (see Table 14) to check the parameter values for the various devices and sensors configured.

NOTE: For information about menu navigation and use of the keypad, see Interface Overview on page 37.

Checkout Tests

Use the Checkout menu (see page 41) to test the damper operation and any configured outputs. Only items that are configured are shown in the Checkout menu.

NOTE: For information about menu navigation and use of the keypad, see Interface Overview on page 37.

To perform a Checkout test:

1. Scroll to the desired test in the Checkout menu using the ▲ and ▼ buttons.
2. Press the ↵ (Enter) button to select the item. RUN? appears.
3. Press the ↵ (Enter) button to start the test. The unit pauses and then displays IN PROGRESS. When the test is complete, DONE appears.
4. When all desired parameters have been tested, press the ⬆ (Menu Up) button to end the test.

The Checkout tests can all be performed at the time of installation or at any time during the operation of the system as a test that the system is operable.

CAUTION

Failure to follow this caution may result in damage to equipment. Be sure to allow enough time for compressor startup and shutdown between checkout tests so that you do not short-cycle the compressors.

TROUBLESHOOTING

Alarms

The economizer module provides alarm messages that display on the 2-line LCD.

NOTE: Upon power up, the module waits 60 minutes before checking for alarms. This allows time for all the configured devices (e.g. sensors, actuator) to become operational. The exception is the SAT sensor which will alarm immediately.



If one or more alarms are present and there has been no keypad activity for at least 5 minutes, the Alarms menu displays and cycles through the active alarms.

You can also navigate to the Alarms menu at any time.

Clearing Alarms

Once the alarm has been identified and the cause has been removed (e.g. replaced faulty sensor) the alarm can be cleared from the display.

To clear an alarm, perform the following:

1. Navigate to the desired alarm.
2. Press the  (Enter) button. ERASE? displays.
3. Press the  (Enter) button. ALARM ERASED displays.
4. Press the  (Menu up/Exit) button to complete the action and return to the previous menu.

NOTE: If the alarm still exists after clearing it, it is redisplayed within 5 seconds.

Staged Air Volume (SAV™) with Variable Frequency Drive

The Staged Air Volume (SAV) system utilizes a Variable Frequency Drive (VFD) to automatically adjust the indoor fan motor speed in sequence with the unit's ventilation, cooling and heating operation (see Fig. 64 and 65). Per ASHRAE 90.1-2016 during the first stage of cooling operation the SAV system will adjust the fan motor to provide 66% of the design airflow rate for the unit. When the call for the second stage of cooling is required, the SAV system will allow the design airflow rate for the unit established (100%). During the heating mode, the SAV system will allow total design airflow rate (100%) operation. During ventilation mode, the SAV system will operate the fan motor at 66% speed.

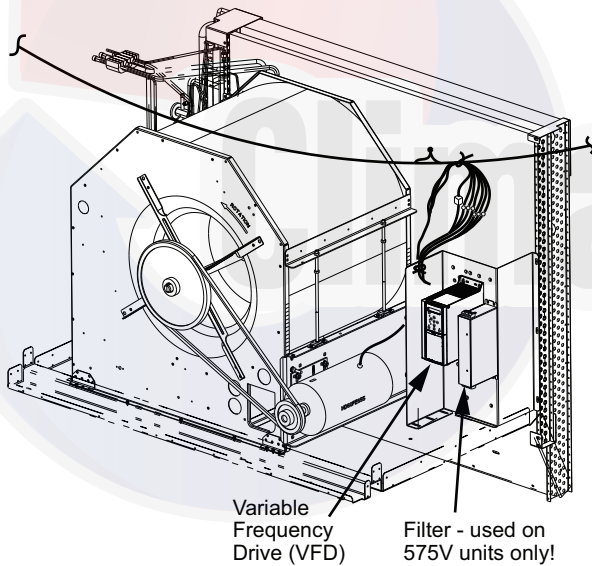

Fig. 64 — VFD Location

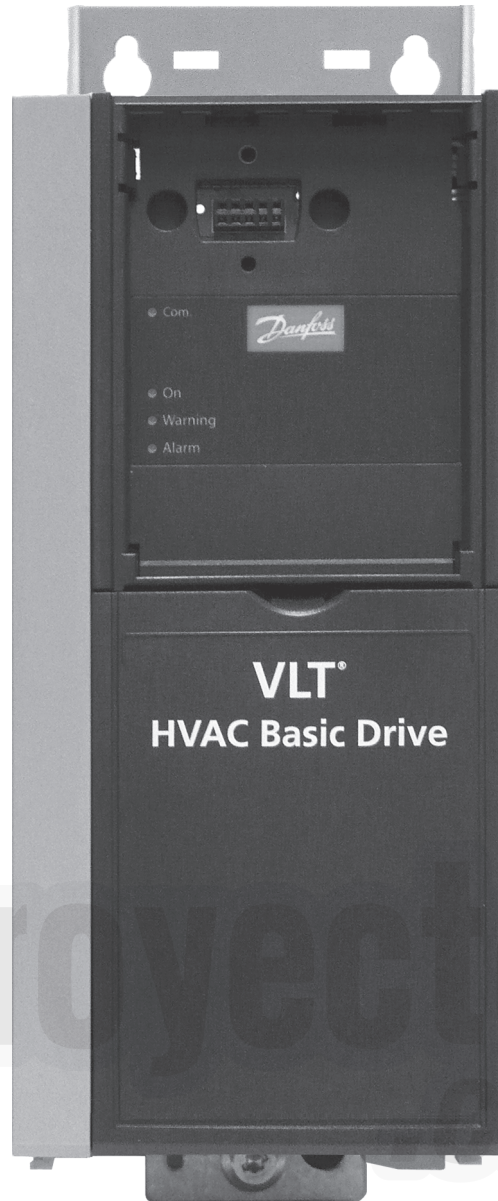

Fig. 65 — Variable Frequency Drive (VFD) Multi-Speed VFD Display Kit (Field-Installed Accessory)

NOTE: The Remote VFD Keypad is part of the Multi-Speed VFD display kit (PN: CRDISKIT002A00) which is a field-installed accessory. It is not included with the 48LC 08-12 base units.

The VFD keypad as shown in Fig. 66 consists of the following sections.

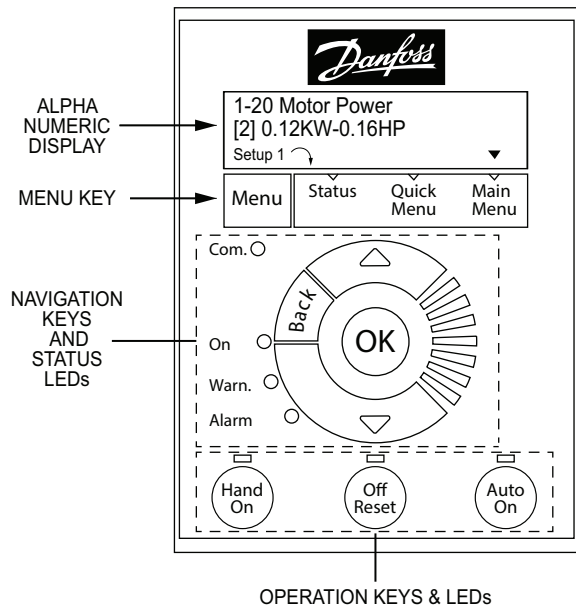
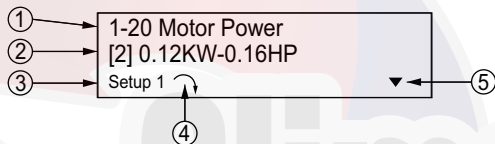

Fig. 66 — VFD Keypad

ALPHA NUMERIC DISPLAY

The LCD display is back lit with 2 alpha-numeric lines. All data is displayed on the LCD.



1	Parameter number and name.
2	Parameter value.
3	Setup number shows the active setup and the edit setup. If the same set-up acts as both the active and edit set-up, only that setup number is shown (factory setting). When the active and edit setup differ, both numbers are shown in the display (SETUP 12). The flashing number indicates the edit setup.
4	The symbol in the number 4 position in the figure above indicates motor direction. The arrow point either clockwise or counter-clockwise to show the motor's current direction.
5	The position of the triangle indicates the currently selected menu: Status, Quick Menu or Main Menu.

Fig. 67 — LCD Alpha Numeric Display

MENU KEY

Use the Menu key to select between Status, Quick Menu or Main Menu. The triangle icon at the bottom of the LCD display indicates the currently selected mode. (See number 5 in Fig. 67.)

NAVIGATION KEYS AND STATUS LEDs

The Navigation keys and Status LEDs are detailed in Fig 68.

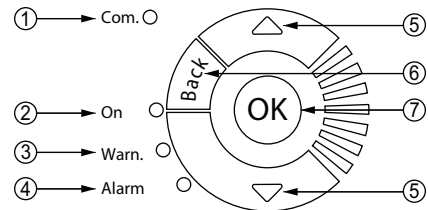

1	Com. LED: Flashes when bus communications is communicating.
2	Green LED/On: Control selection is working.
3	Yellow LED/Warn.: Indicates a warning.
4	Flashing Red LED/Alarm: Indicates an alarm.
5	Arrows ▲ ▼: Use the Up and Down arrow keys to navigate between parameter groups, parameters and within parameters. Also used for setting local reference.
6	Back key: Press to move to the previous step or layer in the navigation structure.
7	OK key: Press to select the currently displayed parameter and for accepting changes to parameter settings.

Fig. 68 — Navigation Keys and Status LEDs

OPERATION KEYS AND LEDS

The following table details the functions of the Operating keys. An illuminated yellow LED above the key indicates the active key. See Fig. 69.

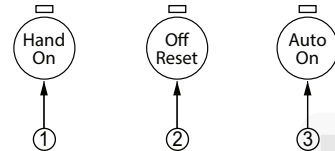

1	Hand On key: Starts the motor and enables control of the variable frequency drive (VFD) via the VFD Keypad option. NOTE: Please note that terminal 27 Digital Input (5-12 Terminal 27 Digital Input) has coast inverse as default setting. This means that the Hand On key will not start the motor if there is no 24V to terminal 27, so be sure to connect terminal 12 to terminal 27.
2	Off/Reset key: Stops the motor (off). If in alarm mode the alarm will be reset.
3	Auto On key: The variable frequency drive is controlled either via control terminals or serial communication.

Fig. 69 — Operating Keys

CONNECTING THE KEYPAD TO THE VFD

The VFD keypad can be mounted directly to the variable frequency drive, provided there is easy access to the front panel of the VFD. If there is no easy access to the VFD front panel, use the cable included with the kit to connect the keypad to the VFD.

Connecting the Keypad Directly to the VFD

1. Place the bottom of the VFD keypad into the variable frequency drive as shown in Fig. 70.

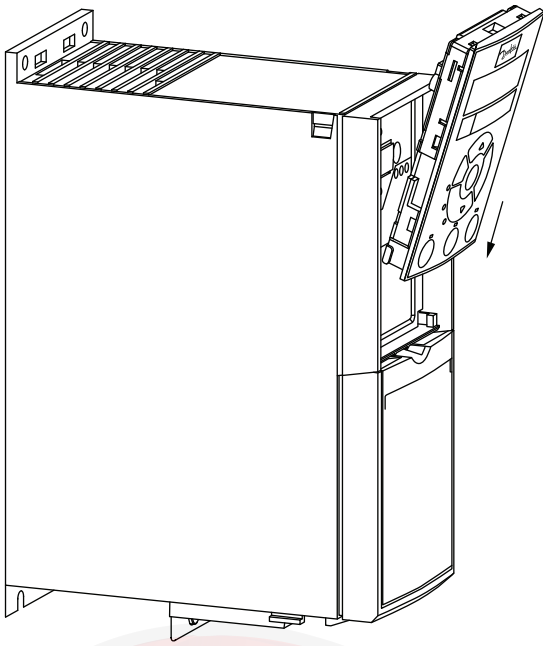

Fig. 70 — Align Bottom of VFD Keypad with Opening in VFD Front Panel

2. Push the top of the VFD keypad into the variable frequency drive as shown in Fig. 71.

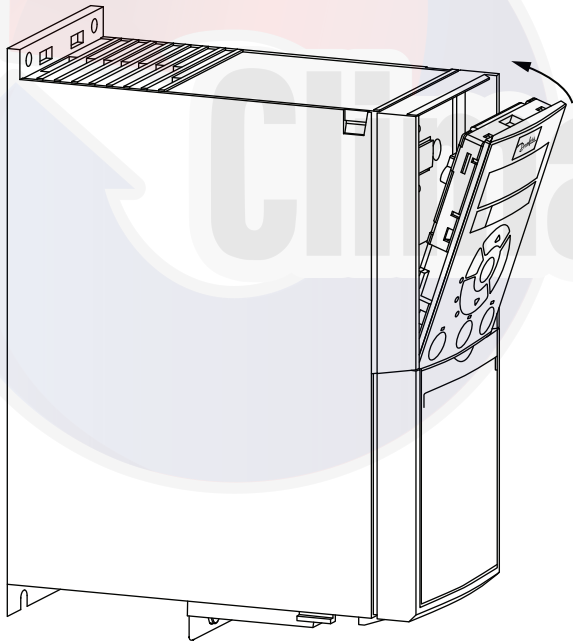

Fig. 71 — Secure Keypad in Place

Using the Cable to Connect the Keypad to the VFD

The VFD keypad can be connected to the variable frequency drive via the cable included with the Multi-Speed VFD display kit (PN: CRDISKIT002A00). See Fig. 72.

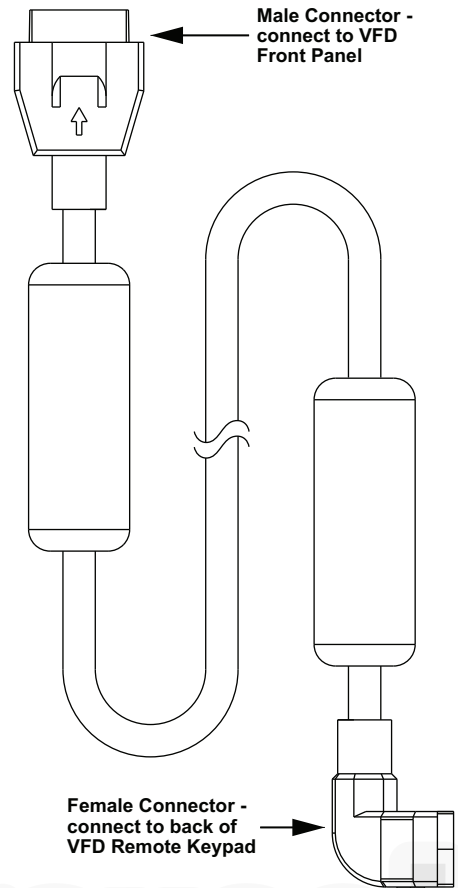

Fig. 72 — VFD Remote Keypad Cable

1. Connect the male end of the cable to the front panel of the variable frequency drive. Use 2 of the screws included with the kit to secure the cable to the VFD.
2. Connect the female end of the cable to the back panel of the VFD Remote keypad. Secure the cable to the remote keypad using the 2 remaining screws from the kit.

PROGRAM THE VFD FOR 3 DISCRETE INDOOR FAN SPEEDS

IMPORTANT: 48LC 08-12 units are programmed at the factory for 3 discrete indoor fan speeds. The following procedure is only to be used to recover this function after an event such as a system crash.

NOTE: This procedure requires use of the VFD Keypad which is included as part of the field-installed Multi-Speed VFD display kit (PN: CRDISKIT002A00). If the VFD keypad is not already installed, install it. See “Connecting the Keypad to the VFD” for details.

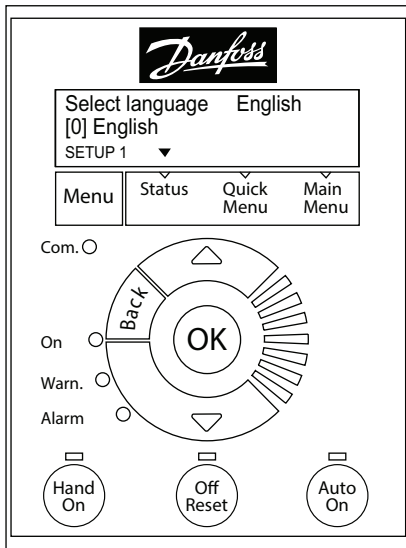

Fig. 73 — Keypad with Power up Screen Displayed

To program the VFD for 3 discreet indoor fan motor speeds:

1. At Power-Up (see Fig. 73):
At the first power up, the LCD displays the Select Language screen. The default setting is English. To change the language, press the OK key and use the ▲ and ▼ keys to scroll to the desired language and then press OK.
2. Selecting Regional Settings:
 - a. Press the Off Reset key.
 - b. Press the Menu key to move the ▼ (triangle icon) so it is positioned over Main Menu. The display shows the following.

0—** Operation / Display
1—** Load and Motor

- c. Press the OK key and the display changes to:

0—0* Basic Settings
0—1* Set-up Operations

- d. With the top row highlighted, press OK. The display changes to:

0—01 Language
[0] English

NOTE: If English is not the desired language, press OK, select the desired language and press OK again.

- e. Press ▼ (Down Arrow key) once; the display changes to:

0—03 Regional Settings
[0] International

- f. Press OK; the [0] is now highlighted.
- g. Press ▼ (Down Arrow) key once; the display changes to:

0—03 Regional Settings
[1] North America

- h. Press OK

NOTE: If the Alarm 060 appears, follow Step 3 to clear the alarm. Make sure to press Off Reset when done. If there is no alarm, continue at Step 4.

3. Clearing Alarm 060: External Interlock:
 - a. Press the Menu key twice to position the ▼ (triangle icon) over Main Menu; the display changes to:

0—** Operation / Display
1—** Load and Motor

- b. Press the ▼ (Down Arrow) key until the following display appears:

4—** Limits / Warnings
5—** Digital In/Out

- c. Press OK. The display changes to:

5—0* Digital I/O Mode
5—1* Digital Inputs

- d. Press ▼ (Down Arrow) once to highlight the bottom row and press OK. The display changes to:

5—10 Terminal 18 Digital In...
[8] Start

- e. Press ▼ (Down Arrow) twice; the following display appears:

5—12 Terminal 27 Digital In...
[7] External Interlock

- f. Press OK to highlight the number in the bracket.
- g. Press ▼ (Down Arrow) until the following display appears:

5—12 Terminal 27 Digital In...
[0] No operation

- h. Press OK.
- i. Press Off Reset. The Alarm indicator disappears.

4. Entering Grid Type:

- a. Press the Menu key to move the ▼ (triangle icon) so it is positioned over Main Menu. The display shows the following:

0—0* Basic Settings
0—1* Set-up Operations

- b. Press OK twice; the display changes to:

0—01 Language
[0] English

- c. Press ▼ (Down Arrow) three times to reach the following display:

0—06 Grid Type
[102] 200-240V/60Hz

- d. Press OK to highlight the number in the bracket and then use the ▲ and ▼ (Up and Down Arrow) keys to select the desired voltage and Hertz for the unit.

- e. Press OK to accept the selection and continue.

5. Entering Motor Data:

- a. Press the Menu key to move the ▼ (triangle icon) so it is positioned over Main Menu. The display shows the following:

0—** Operation / Display
1—** Load and Motor

- b. Press (Down Arrow) once to highlight the bottom row.

- c. Press OK, the display changes to:

1—0* General Settings
1—1* Motor Selection

- d. Press ▼ (Down Arrow) twice to reach the following display:

1—1* Motor Selection
1—2* Motor Data

- e. Press OK; the following display appears:

1-20 Motor Power
[9] 1.5kW - 2 hp

NOTE: The number in the bracket may be different from what is shown above.

- f. Press OK and then use the ▲ and ▼ (Up and Down Arrow) keys to scroll to the proper motor horsepower. Press OK again to set the selected hp.
 g. Press ▼ (Down Arrow) once, the following display appears:

1-22 Motor Voltage
230V

- h. Press OK to highlight the voltage value. Use the ▲ and ▼ (Up and Down Arrow) keys to select the nameplate voltage. Press OK again to set the selected voltage.
 i. Press ▼ (Down Arrow) once to display the following:

1-23 Motor Frequency
60Hz

- j. Press OK to highlight the Frequency value and then use the ▲ and ▼ (Up and Down Arrow) keys to select the nameplate Hz. Press OK again to set the selected Hz.
 k. Press ▼ (Down Arrow) once to display the following:

1-24 Motor Current
6.61A

- l. Press OK to highlight the Current value and then use the ▲ and ▼ (Up and Down Arrow) keys to select the Max Amps value provided. Press OK again to set the selected Max Amps.

NOTE: The Max Amps is greater than the nameplate value. Check the VFD Unit Parameters (see Tables 26-28 on pages 55-58) and use the value listed for the given unit in the column labeled “Motor Current Must-Hold Amps”.

- m. Press ▼ (Down Arrow) once to display the following

1-25 Motor Nominal Speed
1740rpm

- n. Press OK to highlight the rpm value and then use the ▲ and ▼ (Up and Down Arrow) keys to select the nameplate rpm. Press OK again to set the selected rpm.

6. Entering Parameters for 1-71, 1-73, 1-82, and 1-90:

- a. Press the Menu key to move the ▼ (triangle icon) so it is positioned over Main Menu. The display shows the following:

0—** Operation / Display
1—** Load and Motor

- b. Press ▼ (Down Arrow) once to highlight the bottom row.
 c. Press OK, the display changes to:

1—0* General Settings
1—1* Motor Selection

- d. Press ▼ (Down Arrow) until the following display appears:

1—6* Load Depen. Setting
1—7* Start Adjustments

- e. Press OK, the following display appears:

1-71 Start Delay
2.0s

- f. Press OK to highlight the number and then use the ▲ and ▼ (Up and Down Arrow) keys to select the number provided in Tables 26-28. Press OK again to set the selected value.

- g. Press ▼ (Down Arrow) twice, the following display appears:

1-73 Flying Start
[1] Enabled

- h. Press OK to highlight the number in the bracket and then use the ▲ and ▼ (Up and Down Arrow) keys to select the number provided in Table 26-28. Press OK again to set the selected value.

- i. Press the Back key once, the following display appears:

1—6* Load Depen. Setting
1—7* Start Adjustments

- j. Press ▼ (Down Arrow) once, the following display appears:

1—7* Start Adjustments
1—8* Stop Adjustments

- k. Press OK, the following display appears:

1-80 Function at Stop
[0] Coast

- l. Press ▼ (Down Arrow) once, the following display appears:

1-82 Min Speed for Functio...
1.0 Hz

- m. Press OK to highlight the number and then use the ▲ and ▼ (Up and Down Arrow) keys to select the number provided in Tables 26-28. Press OK again to set the selected value.

- n. Press the Back key once, the following display appears:

1—7* Start Adjustments
1—8* Stop Adjustments

- o. Press ▼ (Down Arrow) once, the following display appears:

1—8* Stop Adjustments
1—9* Motor Temperature

- p. Press OK, the following display appears:

1-90 Motor Thermal Prote...
[4] ETR trip 1

- q. Press OK to highlight the number in the bracket then use the ▲ and ▼ (Up and Down Arrow) keys to select the number provided in Tables 26-28. Press OK again to set the selected value.

7. Setting References:

- a. Press the Menu key to move the ▼ (triangle icon) so it is positioned over Main Menu. The display shows the following:

0—** Operation / Display
1—** Load and Motor

- b. Press ▼ (Down Arrow) three times, the following display appears:

2—** Brakes
3—** Reference / Ramps

- c. Press OK, the following display appears:

3—0* Reference Limits
3—1* References

- d. Press OK again, the following display appears:

3-02 Minimum Reference
0.000

NOTE: If the bottom row displays a number other than 0.000, press OK and use the ▲ and ▼ (Up and Down Arrow) key to select 0.000.

- e. Press ▼ (Down Arrow) once, the following display appears:

3-03 Maximum Reference
60.000

NOTE: If the bottom row displays a number other than 60.000, press OK and use the ▲ and ▼ (Up and Down Arrow) key to select 60.000.

- f. Press the Back key until the following display appears:

3—0* Reference Limits
3—1* References

- g. Press ▼ (Down Arrow) once to move the highlight to the bottom row and then press OK. The following display appears:

3-10 Preset Reference
[0]0.00%

- h. Press OK once to highlight the number in the bracket. Press OK again; the highlight moves to the current percent value. Use the ▲ and ▼ (Up and Down Arrow) keys and the table below to enter the required Preset Reference values.

[0]0.00%	Stop
[1]LL.LL%	Low Speed (see Tables 26-28, column labeled "Preset References 3-10[1]" for the proper % for each unit)
[2]MM.MM%	Medium Speed (see Table 26-28, column labeled "Preset References 3-10[2]" for the proper % for each unit)
[3]100%	Override (High Speed)
[4]100%	High Speed (100% or close to 100% to achieve the required CFM at high speed)
[5]0.00%	Stop
[6]0.00%	Stop
[7]0.00%	Stop

8. Setting the Ramp Time:

- a. Press the Back key until the following display appears:

3—0* Reference Limits
3—1* References

- b. Press ▼ (Down Arrow) twice, the following display appears:

3—1* References
3—4* Ramp 1

- c. Press OK, the following display appears:

3-41 Ramp 1 Ramp up Time
3.00s

- d. Press OK again to highlight the bottom row and use the ▲ and ▼ (Up and Down Arrow) keys to select 10.00s. Press OK again to set the selected Ramp up Time.

- e. Press ▼ (Down Arrow) once, the following display appears:

3-42 Ramp 1 Ramp Down Time
3.00s

- f. Press OK again to highlight the bottom row and use the ▲ and ▼ (Up and Down Arrow) keys to select 10.00s. Press OK again to set the selected Ramp Down Time.

9. Setting Limits:

- a. Press the Back key until the following display appears:

2—** Brakes
3—** Reference / Ramps

- b. Press ▼ (Down Arrow) once, the following display appears:

3—** Reference / Ramps
4—** Limits / Warnings

- c. Press OK, the following display appears:

4—1* Motor Limits
4—4* Adj. Warning 2

- d. Press OK again, the following display appears:

4-10 Motor Speed Direction
[2] Both Directions

- e. Press ▼ (Down Arrow) once, the following display appears:

4-12 Motor Speed Low Limi...
0.0Hz

- f. Press ▼ (Down Arrow) again, the following display appears:

4-14 Motor Speed High Limi...
65.0Hz

NOTE: Press OK to highlight the Hz value and then use the ▲ and ▼ (Up and Down Arrow) keys to enter the required values.

- g. Press ▼ (Down Arrow) once, the following display appears:

4-18 Current Limit
110%

NOTE: Press OK to highlight the % value and then use the ▲ and ▼ (Up and Down Arrow) keys to enter the required value. See Tables 26-28 for proper selection of the value for this parameter; then press OK to set the selected value.

- h. Press ▼ (Down Arrow) once, the following display appears:

4-19 Max Output Frequency
65.0Hz

NOTE: Press OK to highlight the Hz value and then use the ▲ and ▼ (Up and Down Arrow) keys to enter the required values.

10. Setting Digital Inputs:

- a. Press the Back key until the following display appears:

3—** Reference / Ramps
4—** Limits / Warnings

- b. Press ▼ (Down Arrow) once, the following display appears:

4—** Limits / Warnings
5—** Digital In/Out

- c. Press OK, the following display appears:

5—0* Digital I/O mode
5—1* Digital Inputs

- d. Press ▼ (Down Arrow) once to move the highlight to the bottom row and then press OK. The following display appears:

5-10 Terminal 18 Digital In...
[8] Start

- e. Press ▼ (Down Arrow) again. The following display appears:

5-11 Terminal 19 Digital In...
[16] Preset ref bit 0

- f. Press ▼ (Down Arrow) again. The following display appears:

5-12 Terminal 27 Digital In...
[17] Preset ref bit 1

- g. Press ▼ (Down Arrow) again. The following display appears:

5-13 Terminal 29 Digital In...
[18] Preset ref bit 2

NOTE: By pressing OK, the number in the bracket can be changed until the desired number appears. Press OK again to set the selected value.

11. Setting Analog Inputs:

- a. Press the Back key until the following display appears:

4—** Limits / Warnings
5—** Digital In/Out

- b. Press ▼ (Down Arrow) until the following display appears:

5—** Digital In/Out
6—** Analog In/Out

- c. Press OK, the following display appears:

6—** Analog In/Out
6—1* Analog Input 53

- d. Press ▼ (Down Arrow) once to move the highlight to the bottom row and then press OK. The following display appears:

6-10 Terminal 53 Low Voltage
2V

- e. Press ▼ (Down Arrow) once to move the highlight to the bottom row and then press OK. The following display appears:

6-11 Terminal 53 High Voltage
[10V]

- f. Press ▼ (Down Arrow) once to move the highlight to the bottom row and then press OK. The following display appears:

6-14 Set Min Reference
[0 Hz]

- g. Press ▼ (Down Arrow) once to move the highlight to the bottom row and then press OK. The following display appears:

6-15 Set Max Reference
[60 Hz]

12. Setting Reset Mode and RFI Filter:

- a. Press the Back key until the following display appears:

0—** Operation / Display
1—** Load and Motor

- b. Press ▼ (Down Arrow) until the following display appears:

13—** Smart Logic
14—** Special Functions

- c. Press OK, the following display appears:

14—0* Inverter Switching
14—1* Mains On/Off

- d. Press ▼ (Down Arrow) twice. The following display appears:

14—1* Mains On/Off
14—2* Reset Functions

- e. Press OK, the following display appears:

14-20 Reset Mode
[0] Manual reset

- f. Press OK to highlight the number in the bracket.

- g. Use the ▲ and ▼ (Up and Down Arrow) keys to change the number to 3 for 3 automatic resets and then press OK. The display changes to:

14-20 Reset Mode
[3] Automatic reset x 3

- h. Press ▼ (Down Arrow) once, the following display appears:

14-21 Automatic Restart T...
10s

- i. Press OK to highlight the number of seconds and use the ▲ and ▼ (Up and Down Arrow) keys to select 600 seconds. Press OK again to set the selected value.

- j. Press the Back key once, the following display appears:

14—1* Mains On/Off
14—2* Reset Functions

- k. Press ▼ (Down Arrow) twice, the following display appears:

14—4* Energy Optimising
14—5* Environment

- l. Press OK, the following display appears:

14-50 RFI Filter
[1] On

- m. Press OK to highlight the number in the bracket and use the ▲ and ▼ (Up and Down Arrow) keys to select [0]. Press OK again to set the selected value.

13. To Complete Reprogramming:

- a. Press the Auto On key before disconnecting the VFD Remote Keypad from the variable frequency drive.

Table 26 — VFD Unit Parameters - 48LC 08 Units

					REGIONAL SETTINGS	GRID TYPE	MOTOR POWER	MOTOR VOLTAGE	MOTOR FREQUENCY (Hz)	MOTOR CURRENT (MUST-HOLD AMPS)	MOTOR NOMINAL SPEED (RPM)
Motor Option	Voltage	Motor P/N	VFD Carrier P/N	VFD Mfr P/N	0-03	0-06	1-20	1-22	1-23	1-24	1-25
STD	208/230V	HD56FR233	HK30WA370	131L9795	[1]	[102]	[9]	230	60	5.8	1695
	460V	HD56FR463	HK30WA376	131L9863	[1]	[122]	[9]	460	60	2.9	1690
	575V	HD56FR579	HK30WA382	131N0225	[1]	[132]	[9]	575	60	3.1	1690
MID	208/230V	HD56FE653	HK30WA371	131L9796	[1]	[102]	[10]	230	60	7.9	1680
	460V	HD56FE653	HK30WA377	131L9864	[1]	[122]	[10]	460	60	3.6	1680
	575V	HD56FE577	HK30WA382	131N0225	[1]	[132]	[11]	575	60	3.8	1680
HIGH	208/230V	HD60FE656	HK30WA372	131L9797	[1]	[102]	[11]	230	60	11.7	1750
	460V	HD60FE656	HK30WA378	131L9865	[1]	[122]	[11]	460	60	5.4	1750
	575V	HD58FE577	HK30WA383	131N0227	[1]	[132]	[11]	575	60	4.9	1710
ULTRA	208/230V	HD60FK658	HK30WA372	131L9797	[1]	[102]	[13]	230	60	13.6	1745
	460V	HD60FK658	HK30WA379	131L9866	[1]	[122]	[13]	460	60	6.8	1745
	575V	HD60FE576	HK30WA387	134F0217	[1]	[132]	[13]	575	60	6.0	1745

		START DELAY (SEC)	FLYING START	MIN SPEED FOR FUNCTION (Hz)	MOTOR THERMAL PROTECTION	PRESET REFERENCE							
Motor Option	Voltage	1-71	1-73	1-82	1-90	3-10 [0]	3-10 [1]	3-10 [2]	3-10 [3]	3-10 [4]	3-10 [5]	3-10 [6]	3-10 [7]
STD	208/230V	2.0	[1]	1.0	[4]	0%	66.50%	66.50%	100%	100%	0%	0%	0%
	460V	2.0	[1]	1.0	[4]	0%	66.50%	66.50%	100%	100%	0%	0%	0%
	575V	2.0	[1]	1.0	[4]	0%	66.50%	66.50%	100%	100%	0%	0%	0%
MID	208/230V	2.0	[1]	1.0	[4]	0%	66.50%	66.50%	100%	100%	0%	0%	0%
	460V	2.0	[1]	1.0	[4]	0%	66.50%	66.50%	100%	100%	0%	0%	0%
	575V	2.0	[1]	1.0	[4]	0%	66.50%	66.50%	100%	100%	0%	0%	0%
HIGH	208/230V	2.0	[1]	1.0	[4]	0%	66.50%	66.50%	100%	100%	0%	0%	0%
	460V	2.0	[1]	1.0	[4]	0%	66.50%	66.50%	100%	100%	0%	0%	0%
	575V	2.0	[1]	1.0	[4]	0%	66.50%	66.50%	100%	100%	0%	0%	0%
ULTRA	208/230V	2.0	[1]	1.0	[4]	0%	66.50%	66.50%	100%	100%	0%	0%	0%
	460V	2.0	[1]	1.0	[4]	0%	66.50%	66.50%	100%	100%	0%	0%	0%
	575V	2.0	[1]	1.0	[4]	0%	66.50%	66.50%	100%	100%	0%	0%	0%

Table 26 — VFD Unit Parameters - 48LC 08 Units (cont)

		RAMP UP TIME (SEC)	RAMP DOWN TIME (SEC)	CURRENT LIMIT	TERMINAL 18 DIGITAL INPUT	TERMINAL 19 DIGITAL INPUT	TERMINAL 27 DIGITAL INPUT	TERMINAL 29 DIGITAL INPUT
Motor Option	Voltage	3-41	3-42	4-18	5-10	5-11	5-12	5-13
STD	208/230V	10.00	10.00	100%	[8]	[16]	[17]	[18]
	460V	10.00	10.00	100%	[8]	[16]	[17]	[18]
	575V	10.00	10.00	100%	[8]	[16]	[17]	[18]
MID	208/230V	10.00	10.00	100%	[8]	[16]	[17]	[18]
	460V	10.00	10.00	100%	[8]	[16]	[17]	[18]
	575V	10.00	10.00	100%	[8]	[16]	[17]	[18]
HIGH	208/230V	10.00	10.00	100%	[8]	[16]	[17]	[18]
	460V	10.00	10.00	100%	[8]	[16]	[17]	[18]
	575V	10.00	10.00	100%	[8]	[16]	[17]	[18]
ULTRA	208/230V	10.00	10.00	100%	[8]	[16]	[17]	[18]
	460V	10.00	10.00	100%	[8]	[16]	[17]	[18]
	575V	10.00	10.00	100%	[8]	[16]	[17]	[18]

		TERMINAL 53 LOW VOLTAGE	TERMINAL 53 HIGH VOLTAGE	TERMINAL 53 LOW REFERENCE	TERMINAL 53 HIGH REFERENCE	RESET MODE	AUTO-RESTART TIME (S)	RFI FILTER
Motor Option	Voltage	6-10	6-11	6-14	6-15	14-20	14-21	14-50
STD	208/230V	2	[10]	0	[60]	[3]	600	[0]
	460V	2	[10]	0	[60]	[3]	600	[0]
	575V	2	[10]	0	[60]	[3]	600	[0]
MID	208/230V	2	[10]	0	[60]	[3]	600	[0]
	460V	2	[10]	0	[60]	[3]	600	[0]
	575V	2	[10]	0	[60]	[3]	600	[0]
HIGH	208/230V	2	[10]	0	[60]	[3]	600	[0]
	460V	2	[10]	0	[60]	[3]	600	[0]
	575V	2	[10]	0	[60]	[3]	600	[0]
ULTRA	208/230V	2	[10]	0	[60]	[3]	600	[0]
	460V	2	[10]	0	[60]	[3]	600	[0]
	575V	2	[10]	0	[60]	[3]	600	[0]

Table 27 — VFD Unit Parameters - 48LC 09 Units

					REGIONAL SETTINGS	GRID TYPE	MOTOR POWER	MOTOR VOLTAGE	MOTOR FREQUENCY (Hz)	MOTOR CURRENT (MUST-HOLD AMPS)	MOTOR NOMINAL SPEED (RPM)
Motor Option	Voltage	Motor P/N	VFD Carrier P/N	VFD Mfr P/N	0-03	0-06	1-20	1-22	1-23	1-24	1-25
STD	208/230V	HD56FR233	HK30WA370	131L9795	[1]	[102]	[9]	230	60	5.8	1695
	460V	HD56FR463	HK30WA376	131L9863	[1]	[122]	[9]	460	60	2.9	1690
	575V	HD56FR579	HK30WA382	131N0225	[1]	[132]	[9]	575	60	3.1	1690
MID	208/230V	HD56FE653	HK30WA371	131L9796	[1]	[102]	[10]	230	60	7.9	1680
	460V	HD56FE653	HK30WA377	131L9864	[1]	[122]	[10]	460	60	3.6	1680
	575V	HD56FE577	HK30WA382	131N0225	[1]	[132]	[11]	575	60	3.8	1680
HIGH	208/230V	HD60FE656	HK30WA372	131L9797	[1]	[102]	[11]	230	60	11.7	1750
	460V	HD60FE656	HK30WA378	131L9865	[1]	[122]	[11]	460	60	5.4	1750
	575V	HD58FE577	HK30WA383	131N0227	[1]	[132]	[11]	575	60	4.9	1710
ULTRA	208/230V	HD60FK658	HK30WA372	131L9797	[1]	[102]	[13]	230	60	13.6	1745
	460V	HD60FK658	HK30WA379	131L9866	[1]	[122]	[13]	460	60	6.8	1745
	575V	HD60FE576	HK30WA387	134F0217	[1]	[132]	[13]	575	60	6.0	1745

Table 27 — VFD Unit Parameters - 48LC 09 Units (cont)

Motor Option	Voltage	START DELAY (SEC)	FLYING START	MIN SPEED FOR FUNCTION (Hz)	MOTOR THERMAL PROTECTION	PRESET REFERENCE							
		1-71	1-73	1-82	1-90	3-10 [0]	3-10 [1]	3-10 [2]	3-10 [3]	3-10 [4]	3-10 [5]	3-10 [6]	3-10 [7]
STD	208/230V	2.0	[1]	1.0	[4]	0%	66.50%	66.50%	100%	100%	0%	0%	0%
	460V	2.0	[1]	1.0	[4]	0%	66.50%	66.50%	100%	100%	0%	0%	0%
	575V	2.0	[1]	1.0	[4]	0%	66.50%	66.50%	100%	100%	0%	0%	0%
MID	208/230V	2.0	[1]	1.0	[4]	0%	66.50%	66.50%	100%	100%	0%	0%	0%
	460V	2.0	[1]	1.0	[4]	0%	66.50%	66.50%	100%	100%	0%	0%	0%
	575V	2.0	[1]	1.0	[4]	0%	66.50%	66.50%	100%	100%	0%	0%	0%
HIGH	208/230V	2.0	[1]	1.0	[4]	0%	66.50%	66.50%	100%	100%	0%	0%	0%
	460V	2.0	[1]	1.0	[4]	0%	66.50%	66.50%	100%	100%	0%	0%	0%
	575V	2.0	[1]	1.0	[4]	0%	66.50%	66.50%	100%	100%	0%	0%	0%5
ULTRA	208/230V	2.0	[1]	1.0	[4]	0%	66.50%	66.50%	100%	100%	0%	0%	0%5
	460V	2.0	[1]	1.0	[4]	0%	66.50%	66.50%	100%	100%	0%	0%	0%
	575V	2.0	[1]	1.0	[4]	0%	66.50%	66.50%	100%	100%	0%	0%	0%

Motor Option	Voltage	RAMP UP TIME (SEC)	RAMP DOWN TIME (SEC)	CURRENT LIMIT	TERMINAL 18 DIGITAL INPUT	TERMINAL 19 DIGITAL INPUT	TERMINAL 27 DIGITAL INPUT	TERMINAL 29 DIGITAL INPUT
		3-41	3-42	4-18	5-10	5-11	5-12	5-13
STD	208/230V	10.00	10.00	100%	[8]	[16]	[17]	[18]
	460V	10.00	10.00	100%	[8]	[16]	[17]	[18]
	575V	10.00	10.00	100%	[8]	[16]	[17]	[18]
MID	208/230V	10.00	10.00	100%	[8]	[16]	[17]	[18]
	460V	10.00	10.00	100%	[8]	[16]	[17]	[18]
	575V	10.00	10.00	100%	[8]	[16]	[17]	[18]
HIGH	208/230V	10.00	10.00	100%	[8]	[16]	[17]	[18]
	460V	10.00	10.00	100%	[8]	[16]	[17]	[18]
	575V	10.00	10.00	100%	[8]	[16]	[17]	[18]
ULTRA	208/230V	10.00	10.00	100%	[8]	[16]	[17]	[18]
	460V	10.00	10.00	100%	[8]	[16]	[17]	[18]
	575V	10.00	10.00	100%	[8]	[16]	[17]	[18]

Motor Option	Voltage	TERMINAL 53 LOW VOLTAGE	TERMINAL 53 HIGH VOLTAGE	TERMINAL 53 LOW REFERENCE	TERMINAL 53 HIGH REFERENCE	RESET MODE	AUTO. RESTART TIME (S)	RFI FILTER
		6-10	6-11	6-14	6-15	14-20	14-21	14-50
STD	208/230V	2	[10]	0	[60]	[3]	600	[0]
	460V	2	[10]	0	[60]	[3]	600	[0]
	575V	2	[10]	0	[60]	[3]	600	[0]
MID	208/230V	2	[10]	0	[60]	[3]	600	[0]
	460V	2	[10]	0	[60]	[3]	600	[0]
	575V	2	[10]	0	[60]	[3]	600	[0]
HIGH	208/230V	2	[10]	0	[60]	[3]	600	[0]
	460V	2	[10]	0	[60]	[3]	600	[0]
	575V	2	[10]	0	[60]	[3]	600	[0]
ULTRA	208/230V	2	[10]	0	[60]	[3]	600	[0]
	460V	2	[10]	0	[60]	[3]	600	[0]
	575V	2	[10]	0	[60]	[3]	600	[0]

Table 28 — VFD Unit Parameters - 48LC 12 Units

					REGIONAL SETTINGS	GRID TYPE	MOTOR POWER	MOTOR VOLTAGE	MOTOR FREQUENCY (Hz)	MOTOR CURRENT (MUST-HOLD AMPS)	MOTOR NOMINAL SPEED (RPM)
Motor Option	Voltage	Motor P/N	VFD Carrier P/N	VFD Mfr P/N	0-03	0-06	1-20	1-22	1-23	1-24	1-25
STD	208/230V	HD56FE653	HK30WA371	131L9796	[1]	[102]	[10]	230	60	7.9	1680
	460V	HD56FE653	HK30WA377	131L9864	[1]	[122]	[10]	460	60	3.6	1680
	575V	HD56FE577	HK30WA382	131N0225	[1]	[132]	[11]	575	60	3.8	1680
MID	208/230V	HD60FE656	HK30WA372	131L9797	[1]	[102]	[11]	230	60	11.7	1750
	460V	HD60FE656	HK30WA378	131L9865	[1]	[122]	[11]	460	60	5.4	1750
	575V	HD58FE577	HK30WA383	131N0227	[1]	[132]	[11]	575	60	4.9	1710
HIGH	208/230V	HD60FK658	HK30WA372	131L9797	[1]	[102]	[13]	230	60	13.6	1745
	460V	HD60FK658	HK30WA379	131L9866	[1]	[122]	[13]	460	60	6.8	1745
	575V	HD60FE576	HK30WA387	134F0217	[1]	[132]	[13]	575	60	6.0	1745

		START DELAY (SEC)	FLYING START	MIN SPEED FOR FUNCTION (Hz)	MOTOR THERMAL PROTECTION	PRESET REFERENCE							
Motor Option	Voltage	1-71	1-73	1-82	1-90	3-10 [0]	3-10 [1]	3-10 [2]	3-10 [3]	3-10 [4]	3-10 [5]	3-10 [6]	3-10 [7]
STD	208/230V	2.0	[1]	1.0	[4]	0%	66.50%	66.50%	100%	100%	0%	0%	0%
	460V	2.0	[1]	1.0	[4]	0%	66.50%	66.50%	100%	100%	0%	0%	0%
	575V	2.0	[1]	1.0	[4]	0%	66.50%	66.50%	100%	100%	0%	0%	0%
MID	208/230V	2.0	[1]	1.0	[4]	0%	66.50%	66.50%	100%	100%	0%	0%	0%
	460V	2.0	[1]	1.0	[4]	0%	66.50%	66.50%	100%	100%	0%	0%	0%
	575V	2.0	[1]	1.0	[4]	0%	66.50%	66.50%	100%	100%	0%	0%	0%
HIGH	208/230V	2.0	[1]	1.0	[4]	0%	66.50%	66.50%	100%	100%	0%	0%	0%
	460V	2.0	[1]	1.0	[4]	0%	66.50%	66.50%	100%	100%	0%	0%	0%
	575V	2.0	[1]	1.0	[4]	0%	66.50%	66.50%	100%	100%	0%	0%	0%

		RAMP UP TIME (SEC)	RAMP DOWN TIME (SEC)	CURRENT LIMIT	TERMINAL 18 DIGITAL INPUT	TERMINAL 19 DIGITAL INPUT	TERMINAL 27 DIGITAL INPUT	TERMINAL 29 DIGITAL INPUT
Motor Option	Voltage	3-41	3-42	4-18	5-10	5-11	5-12	5-13
STD	208/230V	10.00	10.00	100%	[8]	[16]	[17]	[18]
	460V	10.00	10.00	100%	[8]	[16]	[17]	[18]
	575V	10.00	10.00	100%	[8]	[16]	[17]	[18]
MID	208/230V	10.00	10.00	100%	[8]	[16]	[17]	[18]
	460V	10.00	10.00	100%	[8]	[16]	[17]	[18]
	575V	10.00	10.00	100%	[8]	[16]	[17]	[18]
HIGH	208/230V	10.00	10.00	100%	[8]	[16]	[17]	[18]
	460V	10.00	10.00	100%	[8]	[16]	[17]	[18]
	575V	10.00	10.00	100%	[8]	[16]	[17]	[18]

		TERMINAL 53 LOW VOLTAGE	TERMINAL 53 HIGH VOLTAGE	TERMINAL 53 LOW REFERENCE	TERMINAL 53 HIGH REFERENCE	RESET MODE	AUTO. RESTART TIME (S)	RFI FILTER
Motor Option	Voltage	6-10	6-11	6-14	6-15	14-20	14-21	14-50
STD	208/230V	2	[10]	0	[60]	[3]	600	[0]
	460V	2	[10]	0	[60]	[3]	600	[0]
	575V	2	[10]	0	[60]	[3]	600	[0]
MID	208/230V	2	[10]	0	[60]	[3]	600	[0]
	460V	2	[10]	0	[60]	[3]	600	[0]
	575V	2	[10]	0	[60]	[3]	600	[0]
HIGH	208/230V	2	[10]	0	[60]	[3]	600	[0]
	460V	2	[10]	0	[60]	[3]	600	[0]
	575V	2	[10]	0	[60]	[3]	600	[0]

Smoke Detectors

Smoke detectors are available as factory-installed options on 48LC 08-12 units. Smoke detectors may be specified for supply air only, for return air without or with economizer, or in combination of supply air and return air. Return air smoke detectors are arranged for vertical return configurations only. All components necessary for operation are factory-provided and mounted. The unit is factory-configured for immediate smoke detector shutdown operation; additional wiring or modifications to the Integrated Staging Control (ISC) board may be necessary to complete the unit and smoke detector configuration to meet project requirements.

Units equipped with factory-optional return air smoke detectors require a relocation of the sensor module at unit installation. See Fig. 74 for the as-shipped location.

COMPLETING INSTALLATION OF RETURN-AIR SMOKE SENSOR

1. Unscrew the two screws holding the return air smoke detector assembly. See Fig. 75, Step 1. Save the screws.
2. Turn the assembly 90 degrees and then rotate end to end. Make sure that the elbow fitting is pointing down. See Fig. 75, Step 2.
3. Screw the sensor and detector plate into its operating position using screws from Step 1. See Fig. 75, Step 3.
4. Connect the flexible tube on the sampling inlet to the sampling tube on the basepan.

ADDITIONAL APPLICATION DATA

Refer to *Factory Installed Smoke Detectors for Small and Medium Rooftop Units 2 to 25 Tons* for discussions on additional control features of these smoke detectors, including multiple unit coordination.

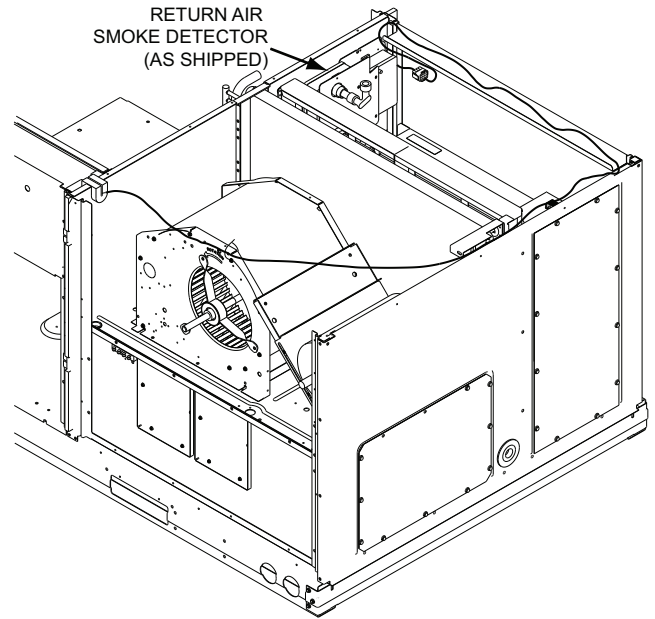

Fig. 74 — Return-Air Smoke Detector (Shipping Position)

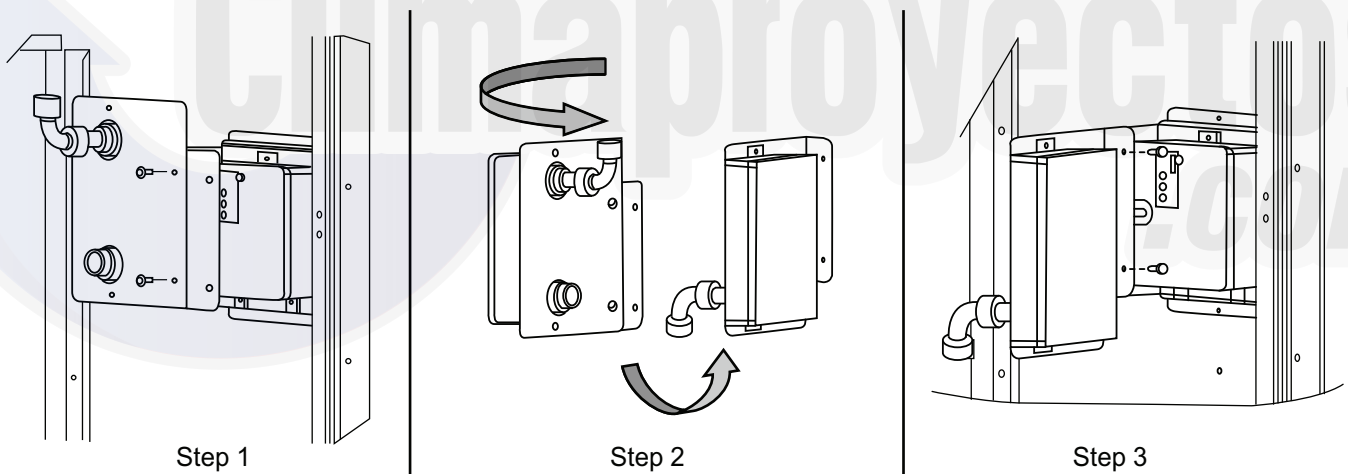

Fig. 75 — Completing Installation of Return-Air Smoke Sensor

Step 13 — Adjust Factory-Installed Options

SMOKE DETECTORS

Smoke detector(s) will be connected at the Integrated Staging Control (ISC) board, at terminals marked “Smoke Shutdown”. Remove jumper JMP 3 when ready to energize unit.

Step 14 — Install Accessories

Available accessories include:

- Roof Curb (must be installed before unit)
- Thru-base connection kit (must be installed before unit is set on curb)
- EconoMi\$er® X (with control)
- Power Exhaust
- Outdoor enthalpy sensor
- Differential enthalpy sensor
- CO₂ sensor
- Temperature and Humidity sensors
- Louvered hail guard
- Phase monitor control

Refer to separate installation instructions for information on installing these accessories. See Price Pages for a complete list of field-installed accessories.

Step 15 — Check Belt Tension

Measure the belt span length as shown in Fig. 76. Calculate the required deflection by multiplying the belt span length by $\frac{1}{64}$. For example, if the belt span length is 32 inches:

$$32 \times \frac{1}{64} = \frac{1}{2}\text{-in. deflection.}$$

BELT FORCE — DEFLECTION METHOD

Check the belt tension with a spring-force belt force deflection gage (available from drive belt manufacturer).

1. Place a straightedge along the belt between the two pulleys. Measure the distance between the motor shaft and the blower shaft.
2. Set the tension gage to the desired tension (see Table 1 in Fig. 76). Place the large O-ring at that point.
3. Press the tension checker downward on the belt until the large O-ring is at the bottom of the straightedge.
4. Adjust the belt tension as needed.

Adjust belt tension by loosening the motor mounting plate front bolts and rear bolt (see Fig. 77) and slide the plate towards the fan (to reduce tension) or away from the fan (to increase tension). Ensure the blower shaft and motor shaft are parallel to each other (pulleys aligned). Tighten all bolts securely when finished.

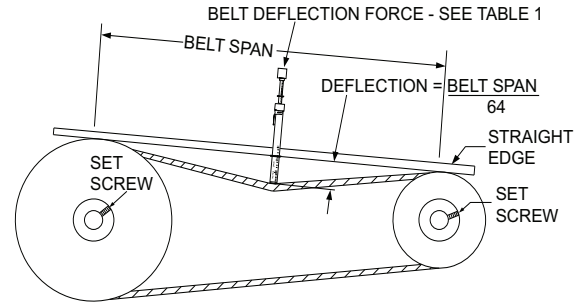

TORQUE ALL SHEAVE SET SCREWS TO 110-130 in. lbs

BELT CROSS SECTION	SMALLEST SHEAVE DIAMETER	BELT DEFLECTION FORCE (LBS)			
		UNNOTCHED BELTS		NOTCHED BELTS	
		USED	NEW	USED	NEW
A, AX	3.0-3.6	3.7	5.5	4.1	6.1
	3.8-4.8	4.5	6.8	5.0	7.4
	5.0-7.0	5.4	8.0	5.7	8.4
B, BX	3.4-4.2	—	—	4.9	7.2
	4.4-5.6	5.3	7.9	7.1	10.5
	5.8-8.6	6.3	9.4	8.5	12.6

Table 1

BELT CONDITION	TENSION FORCE IN BELT (LBS)
New	100
Used	80

Table 2

Fig. 76 — V-Belt Force Label

BELT TENSION METHOD

Requires belt tension gage that measures tension in belt in units of lbs force.

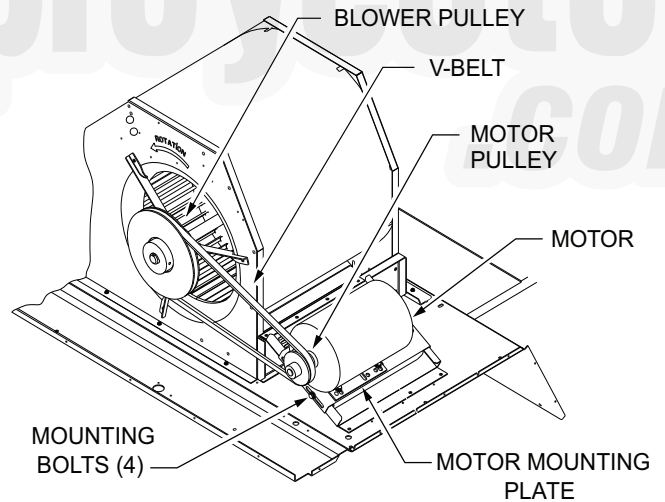

Fig. 77 — Belt Drive Motor Mounting



START-UP CHECKLIST FOR 48LC SINGLE PACKAGE ROOFTOP UNIT

(Remove and Store in Job File)

NOTE: To avoid injury to personnel and damage to equipment or property when completing the procedures listed in this start-up checklist, use good judgment, follow safe practices, and adhere to the safety considerations/information as outlined in preceding sections of this Installation Instruction document.

I. PRELIMINARY INFORMATION

MODEL NO. _____

JOB NAME _____

SERIAL NO.. _____

ADDRESS _____

START-UP DATE _____

TECHNICIAN NAME _____

ADDITIONAL ACCESSORIES _____

II. PRE-START-UP

Verify that all packaging materials have been removed from unit (Y/N) _____

Verify installation of outdoor air hood (Y/N) _____

Verify installation of flue exhaust and inlet hood (Y/N) _____

Verify that condensate connection is installed per instructions (Y/N) _____

Verify that all electrical connections and terminals are tight (Y/N) _____

Verify gas pressure to unit gas valve is within specified range (Y/N) _____

Check gas piping for leaks (Y/N) _____

Check that indoor-air filters are clean and in place (Y/N) _____

Check that outdoor-air inlet screens are in place (Y/N) _____

Verify that unit is level (Y/N) _____

Check fan wheels and propeller for location in housing/orifice and verify setscrew is tight (Y/N) _____

Verify that fan sheaves are aligned and belts are properly tensioned (Y/N) _____

Verify that scroll compressors are rotating in the correct direction (Y/N) _____

Verify installation of thermostat (Y/N) _____

Verify that crankcase heaters have been energized for at least 24 hours (Y/N) _____

III. START-UP

ELECTRICAL

Supply Voltage	L1-L2 _____	L2-L3 _____	L3-L1 _____
Compressor Amps 1	L1 _____	L2 _____	L3 _____
Compressor Amps 2	L1 _____	L2 _____	L3 _____
Supply Fan Amps	L1 _____	L2 _____	L3 _____

TEMPERATURES

Outdoor-air Temperature _____ °F DB (Dry Bulb)

Return-air Temperature _____ °F DB _____ °F Wb (Wet Bulb)

Cooling Supply Air Temperature _____ °F

Gas Heat Supply Air Temperature _____ °F

PRESSURES

Gas Inlet Pressure _____ IN. WG

Gas Manifold Pressure STAGE 1 _____ IN. WG

STAGE 2 _____ IN. WG

Manufacturer reserves the right to discontinue, or change at any time, specifications or designs without notice and without incurring obligations.

