



Controls, Start-Up, Operation, and Troubleshooting

NOTE: This literature covers 48/50LC 04-26 models with SystemVu controls version 3.X (factory-installed option).

CONTENTS

SAFETY CONSIDERATIONS	2	Dehumidification Control	14
GENERAL	2	Remote Occupancy	14
Conventions Used in This Manual	3	Remote Shutdown	14
BASIC CONTROL USAGE	3	Alarm Output	14
SystemVu Control (factory-installed option)	3	Economizer Damper Control	14
SystemVu Interface	3	CONTROLS OPERATION	14
Accessory Navigator Display	5	Display Configuration	14
System Pilot™ and Touch Pilot™ Devices	7	Unit Configuration	15
CCN Tables and Display	7	GENERAL OPERATION	15
START-UP	7	Demand Determination	16
Unit Preparation	7	Occupancy Determination	17
Refrigerant Service Ports	7	Indoor Fan Operation	18
Crankcase Heater	7	Cooling Operation	19
Compressor Rotation	7	Optional Humidi-MiZer Dehumidification System ..	21
Power Supply	7	Indoor Fan Based Dehumidification	25
Internal Wiring	8	Heating Operation	25
Evaporator Fan	8	Supply Air Tempering	26
Condenser Fans and Motors	8	Economizer Operation	27
Return-Air Filters	8	Power Exhaust	29
Outdoor-Air Inlet Screens	8	Indoor Air Quality (IAQ)	30
Accessory Installation	8	Pre-occupancy Purge	31
Gas Heat (48LC units only)	10	Temperature Compensated Start	31
CONTROLS QUICK SET-UP	10	Linkage	31
Control Set Point and Configuration Log	10	Carrier Comfort Network® (CCN) Operation	31
Initial Startup	11	BACnet Network Operation	32
Thermostat Control	11	Alarm Handling	32
Space Temperature Sensor Control - Direct		TROUBLESHOOTING	32
Wired (T-55 or T-56 or T-59)	11	Complete Unit Stoppage	32
Space Humidistat Control	11	Restart Procedure	32
Relative Humidity Sensor Control	11	Faults and Alerts	32
CCN Communication	11	Control Module Communication	40
CCN Linkage Control	11	Communication Failures	40
System Pilot™ – Communication Space Sensor ..	11	Cooling Troubleshooting	40
SystemVu™ Controller	11	Humidi-MiZer® System Troubleshooting	41
Accessories	11	Economizer Troubleshooting	43
Programming Operating Schedules	12	Heating Troubleshooting	44
SERVICE TEST	12	Phase Protection	47
Independent Outputs	13	Thermistor Troubleshooting	47
Fan Test	13	Sensor Trim	48
Cooling Test	13	Transducer Troubleshooting	48
Heating Test	13	MAJOR SYSTEM COMPONENTS	48
Automatic Test	13	General	48
THIRD PARTY CONTROL	14	Main Base Board (MBB)	67
Cooling/Heating Control	14	Input-Output Board (IOB)	69
		Integrated Gas Control (IGC) Board	70
		Protective Devices	71
		Space Mounted Sensors	71

Variable Frequency Drive (VFD)	73
48/50LC 07-26 Variable Frequency Drive (Danfoss VFD).....	77
Carrier Comfort Network® (CCN) Interface	87
APPENDIX A — SYSTEMVU™ CONTROLLER DISPLAY	89
APPENDIX B — SYSTEMVU CONTROLLER TEXT POINT REFERENCE.....	116
APPENDIX C — NAVIGATOR™ DISPLAY	117
APPENDIX D — SYSTEMVU CONTROLLER CCN TABLES.....	131
APPENDIX E — BACNETS POINT LIST	160
CONTROL SETPOINT AND CONFIGURATION LOG	174
UNIT START-UP CHECKLIST	CL-1

SAFETY CONSIDERATIONS

Installation and servicing of air-conditioning equipment can be hazardous due to system pressure and electrical components. Only trained and qualified service personnel should install, repair, or service air-conditioning equipment.

Untrained personnel can perform basic maintenance functions of cleaning coils and filters and replacing filters. All other operations should be performed by trained service personnel. When working on air-conditioning equipment, observe precautions in the literature, tags and labels attached to the unit, and other safety precautions that may apply.

Follow all safety codes, including ANSI (American National Standards Institute) Z223.1. Wear safety glasses and work gloves. Use quenching cloth for unbrazing operations. Have fire extinguisher available for all brazing operations.

It is important to recognize safety information. This is the safety-alert symbol . When you see this symbol on the unit and in instructions or manuals, be alert to the potential for personal injury.

Understand the signal words DANGER, WARNING, CAUTION, and NOTE. These words are used with the safety-alert symbol. DANGER identifies the most serious hazards which **will** result in severe personal injury or death. WARNING signifies hazards which **could** result in personal injury or death. CAUTION is used to identify unsafe practices, which **may** result in minor personal injury or product and property damage. NOTE is used to highlight suggestions which **will** result in enhanced installation, reliability, or operation.

 WARNING
ELECTRICAL SHOCK HAZARD
Failure to follow this warning could cause personal injury or death.
Before performing service or maintenance operations on unit, turn off main power switch to unit and install lock(s) and lockout tag(s). Ensure electrical service to rooftop unit agrees with voltage and amperage listed on the unit rating plate. Unit may have more than one power switch.

 CAUTION
UNIT DAMAGE HAZARD
This unit uses a microprocessor-based electronic control system. Do not use jumpers or other tools to short out components or to bypass or otherwise depart from recommended procedures. Any short-to-ground of the control board or accompanying wiring may destroy the electronic modules or electrical components.

 WARNING
If the information in this manual is not followed exactly, a fire or explosion may result causing property damage, personal injury or loss of life.
Do not store or use gasoline or other flammable vapors and liquids in the vicinity of this or any other appliance.
WHAT TO DO IF YOU SMELL GAS
<ul style="list-style-type: none"> • Do not try to light any appliance. • Do not touch any electrical switch; do not use any phone in your building. • Immediately call your gas supplier from a neighbor's phone. Follow the gas supplier's instructions. • If you cannot reach your gas supplier, call the fire department.
Installation and service must be performed by a qualified installer, service agency or the gas supplier.

 AVERTISSEMENT
RISQUE D'INCENDIE OU D'EXPLOSION
Si les consignes de sécurité ne sont pas suivies à la lettre, cela peut entraîner la mort, de graves blessures ou des dommages matériels.
Ne pas entreposer ni utiliser d'essence ni autres vapeurs ou liquides inflammables à proximité de cet appareil ou de tout autre appareil.
QUE FAIRE SI UNE ODEUR DE GAZ EST DÉTECTÉE
<ul style="list-style-type: none"> • Ne mettre en marche aucun appareil. • Ne toucher aucun interrupteur électrique; ne pas utiliser de téléphone dans le bâtiment. • Quitter le bâtiment immédiatement. • Appeler immédiatement le fournisseur de gaz en utilisant le téléphone d'un voisin. Suivre les instructions du fournisseur de gaz. • Si le fournisseur de gaz n'est pas accessible, appeler le service d'incendie.
L'installation et l'entretien doivent être effectués par un installateur ou une entreprise d'entretien qualifié, ou le fournisseur de gaz.

GENERAL

This publication contains start-up, controls, operation, service, and troubleshooting information for the 48/50LC rooftop units equipped with the factory-installed optional SystemVu™ controls (version 3.X or higher) and use Puron® (R-410A) refrigerant. See Fig. 1 for the SystemVu controls. The specific base unit installation instructions, service manual and/or wiring label diagram may also be required in conjunction with this book as a guide to a specific unit on the roof. All units in Table 1 are Staged Air Volume (SAV™) units that allow for stand-alone or network operation.

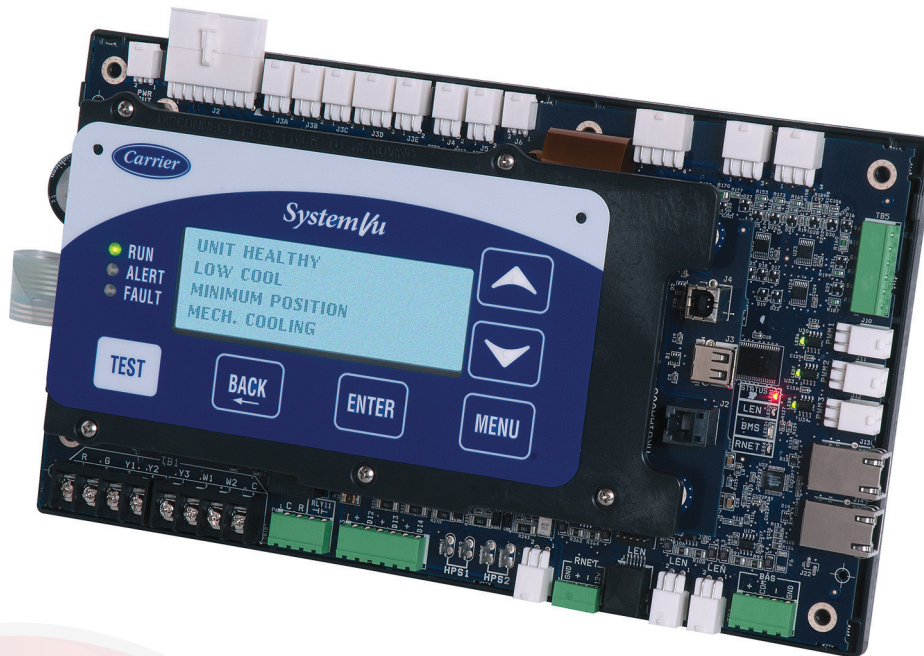

Fig. 1 — SystemVu Controls

Table 1 — Rooftop Units

MODEL	SIZE	NOMINAL TONS
48/50LC	04	3
	05	4
	06	5
	07	6
	08	7.5
	09	8.5
	12	10
	14	12.5
	17	15
	20	17.5
	24	20
26	23	

Conventions Used in This Manual

The following conventions for discussing configuration points for the local display (SystemVu controller or Navigator™ accessory) will be used in this manual.

Menu paths will be written with the main menu name first, then any menus or submenus, each separated by an arrow symbol (→) and will also be shown in bold and italics. As an example, the General submenu, which is located in the Setting main menu under Unit Configuration menu, would be written as ***SETTINGS→UNIT CONFIGURATIONS→GENERAL***.

This path name will show the user how to navigate through the local display to reach the desired menu. The user scrolls through the Menus using the up and down keys. The arrow symbol in the path name represents pressing ENTER to move into the next level of the menu structure.

Point names are referenced in parentheses and in bold and italics as would be shown on the local display.

CCN point names are also referenced for users configuring the unit with CCN software instead of the local display. See Appendix A at the end of this manual.

BASIC CONTROL USAGE

SystemVu Control (factory-installed option)

The SystemVu control is a comprehensive unit-management system. The control system is easy to access, configure, diagnose and troubleshoot.

The SystemVu control system is fully communicating and cable-ready for connection to the Carrier Comfort Network® (CCN), Carrier i-Vu®, and Third Party BACnet¹ building management systems. The control provides high-speed communications for remote monitoring via the Internet. Multiple units can be linked together (and to other Direct Digital Control (DDC) equipped units) using a 3-wire communication bus.

The SystemVu control system is easy to access through the use of an integrated display module. A computer is not required for start-up. Access to control menus is simplified by the ability to quickly select from 7 main menu items. An expanded readout provides detailed explanations of control information. Only six buttons are required to maneuver through the entire controls menu. The display readout is designed to be visible even in bright sunlight.

SystemVu Interface

This integrated device is the keypad interface used to access the control information, read sensor values, and test the unit. The interface is located in the main control box and is standard on all units. The interface is a 6-key, 4x30 character, LCD (liquid-crystal display) display module. The interface also contains Status LEDs. (See Fig. 2.) The interface is easy to operate using 6 buttons and the main menu structures shown in Fig. 3.

Through the SystemVu interface, the user can access all of the inputs and outputs to check on their values and status, configure operating parameters, and evaluate the current decision status for operating modes. The control also includes an alarm history which can be accessed from the display. The user can access a built-in test routine that can be used at start-up commissioning and troubleshooting.

1. BACnet is a registered trademark of ASHRAE (American Society of Heating, Refrigerating and Air-Conditioning Engineers).

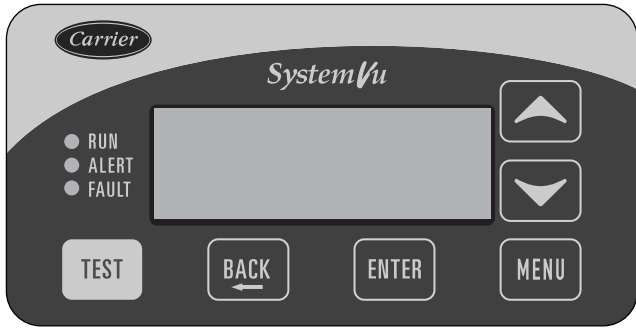

Fig. 2 — SystemVu Interface

SYSTEMVU INTERFACE OPERATION

Units are shipped from the factory with the SystemVu interface FIOP, located in the main control box. (See Fig. 2.) In addition, the interface has up and down arrow keys, BACK, ENTER, MENU, and TEST keys. These keys are used to navigate through the different levels of the menu structure. All discussions and examples in this document will be based on the SystemVu display except in the Navigator™ display section. See the Accessory Navigator Display section for further details and Table 2 for the Navigator menu structure and usage.

The six keys are used to navigate through the display structure, which is organized in a tiered menu structure. If the buttons have not been used for a period of time, the display will default to a standby screen intended to provide a quick overall look at the system. To show the top-level display, first press any key to turn the display backlight on, and then press the MENU key. Then use the up and down arrow keys to scroll through the top-level menus. These are shown in Fig. 3 and listed in Appendix A.

When a specific menu or submenu is located, push the ENTER key to enter the menu. Depending on the menu, there may be additional tiers. Continue to use the up and down keys and the ENTER key until the desired display item is found. At any time, the user can move back a menu level by pressing the BACK key. Once an item has been selected, the display will flash showing the item, followed by the item value and then by the item units (if any). Pressing the TEST button at any time will jump the display to the test menu. Pressing the MENU button any time will jump the display to the main menu.

Items in the Configuration and Service Test menus are password protected. The display will prompt the enter password screen when required. Use the ENTER, BACK, and arrow keys to enter the four digits of the password. The default user password is 1111.

Pressing the BACK and ENTER keys simultaneously will show an expanded text description screen on the display indicating the full meaning of each display point. To put the screen in standby, hold down the BACK key for 5 seconds.

Some points can be forced from the SystemVu interface. To force a variable, follow the same process as editing a configuration parameter. A forced variable, regardless where the force has come from will be displayed with a lower case “f” following its value. For example, if **ECON CMD POSITION** is forced, the display shows “80%f”, where the “f” is to signify a force on the point. Remove the force by selecting the point that is forced with the key ENTER and then pressing the up and down arrow keys simultaneously. Pressing ENTER and BACK on a forced item will display the expanded description for that item including the force level that is currently applied. Depending on the type of unit (48LC or 50LC), factory-installed options, and field-installed accessories, some of the items in the various menus may not apply.

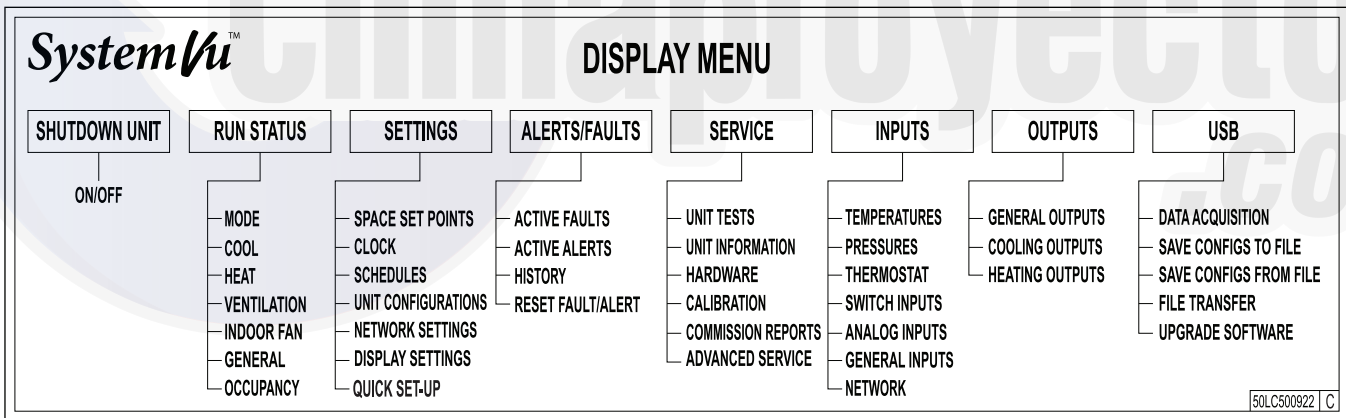

Fig. 3 — SystemVu™ Main Menu Structures

Accessory Navigator Display

The accessory hand-held Navigator display can be used with the 48/50LC units. (See Fig. 4.) The Navigator display is plugged into the LEN (local equipment network) port on either the SystemVu display or the Main Base Board (MBB).

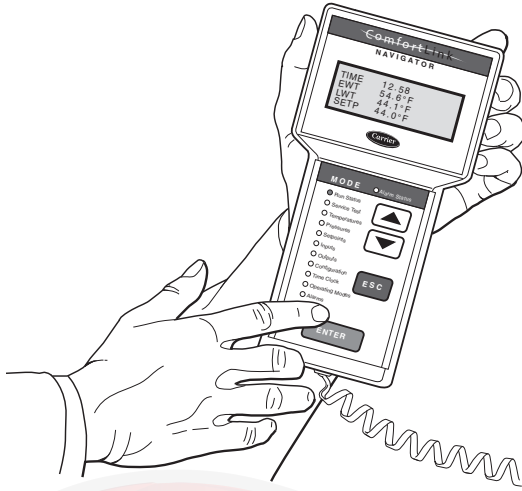

Fig. 4 — Accessory Navigator Display

NAVIGATOR DISPLAY OPERATION

The Navigator display has up and down arrow keys, an ESCAPE key and an ENTER key. These keys are used to navigate through the different levels of the display structure.

The four keys are used to navigate through the display structure, which is organized in a tiered mode structure. If the buttons have not been used for a period, the display will default to the AUTO VIEW display category as shown under the RUN STATUS category. To show the top-level display, press the ESCAPE key until a blank display is shown. Then use the up and down arrow keys to scroll through the top-level categories. These are listed in Appendix C and will be indicated on the Navigator display by the LED next to each mode listed on the face of the display.

When a specific mode or submode is located, push the ENTER key to enter the mode. Depending on the mode, there may be additional tiers. Continue to use the up and down keys and the ENTER keys until the desired display item is found. At any time, the user can move back a mode level by pressing the ESCAPE key. Once an item has been selected the display will flash showing the item, followed by the item value and then followed by the item units (if any).

Items in the Configuration and Service Test modes are password protected. The display will flash PASS and WORD when required. Use the ENTER and arrow keys to enter the four digits of the password. The default password is 1111.

Pressing the ESC and ENTER keys simultaneously will display an expanded text description across the display indicating the full meaning of each display point. Pressing the ESCAPE and ENTER keys when the display is blank (MODE LED level) will return the display to its default menu of rotating AUTO VIEW display items. In addition, the password will need to be entered again before changes can be made.

Changing item values or testing outputs is accomplished in the same manner. Locate and display the desired item. If the display is in rotating auto-view, press the ENTER key to stop the display at the desired item. Press the ENTER key again so that the item value flashes. Use the arrow keys to change the value of state of an item and press the ENTER key to accept it. Press the ESCAPE key and the item, value or units display will resume. Repeat the process as required for other items.

There are some points that can be forced from the Navigator display. If the user needs to force a variable, follow the same process as when editing a configuration parameter. A forced variable, regardless where the force has come from will be displayed with a blinking “f” on a Navigator display following its value. For example, if economizer commanded position (EC.CP) is forced, the Navigator display shows “80P”, where the “f” is blinking to signify a force on the point. Remove the force by selecting the point that is forced with the key ENTER and then pressing the up and down arrow keys simultaneously.

Depending on the type of unit (48LC or 50LC), factory-installed options, and field-installed accessories, some of the items in the various Mode categories may not apply. See Table 2 and Appendix C for full Navigator display menu layout.

Table 2 — Navigator Mode and Menu Display Structure

RUN STATUS	SERVICE TEST	TEMPERATES	PRESSURES	SET POINTS	INPUTS	OUTPUTS	CONFIG.	TIME CLOCK	OPERATING MODES	ALARMS
Auto view of run status (VIEW)	Service Test Mode (TEST)				Thermostat Inputs (STAT)	General Outputs (GEN)	General Unit Config. (GEN)	Time of Day (TIME)		Current Active Alarm (CURR)
↓	↓				↓	↓	↓	↓		↓
Cooling Status (COOL)	Test Independent Outputs (INDP)				Switch Input (SW)	Cooling Outputs (COOL)	Indoor Fan Config. (I.FAN)	Month, Date Day and Year (DATE)		History (HIST)
↓	↓				↓	↓	↓	↓		↓
Heating Status (HEAT)	Test Fans (FAN)				Analog Inputs (AIS)	Heating Outputs (HEAT)	Economizer Config. (ECON)	Daylight Savings Config. (DST)		Reset All Current Alarms (R.CUR)
↓	↓				↓		↓	↓		↓
Ventilation Status (VENT)	Test Cooling (COOL)				General Inputs (GEN)		Building Net Config. (NET)	Schedules Adjust (SCHD)		Alarm Reset History (R.HIS)
↓	↓				↓		↓	↓		
Indoor Fan Status (I.FAN)	Test Heating (HEAT)				Indoor Fan VFD (S.VFD)		User Display Config. (DISP)	Holiday Adjustment (HLDY)		
↓										
Assigned I/O Channels (A.IO)										
↓										
Versions (VERS)										



System Pilot™ and Touch Pilot™ Devices

The System Pilot device (33PILOT-01) and Touch Pilot device (33CNTPILOT) can be used as CCN communication user interfaces. These devices can be put on the CCN bus and addressed to communicate with any other device on the network. Unlike the SystemVu™ display and Navigator display, these pilots read the unit's CCN tables and its CCN points can be monitored, forced, or configured. The Pilot devices can be used to install and commission a 3V™ zoning system, linkage compatible air source, universal controller, and all other devices operating on the Carrier communicating network.

Additionally, the System Pilot device can serve as a wall-mounted temperature sensor for space temperature measurement. Occupants can use the System Pilot device to change set points. See Fig. 5 for System Pilot device details.

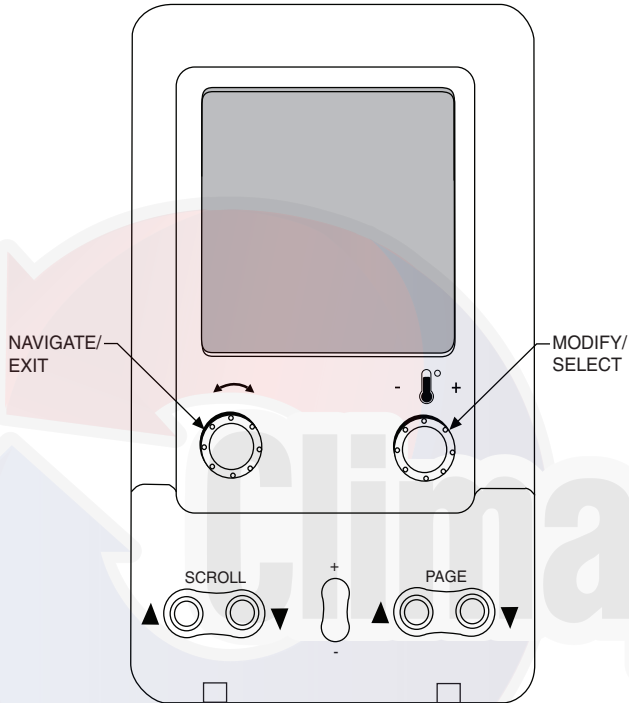

Fig. 5 — System Pilot™ User Interface

CCN Tables and Display

In addition to the unit-mounted SystemVu display, the user can also access the same information through the CCN tables by using the service tool or other CCN programs/devices. The variable names used for the CCN tables and the SystemVu display menus may be different and more items may be displayed in the CCN tables. Details on the CCN tables are included in Appendix D.

FORCE HIERARCHY

There is a hierarchy in SystemVu controls with regards to forcing a point. Programs and devices write a force at different priority levels. A higher level (smaller number, 1 being the highest) will override a lower level force. The SystemVu controller uses a Control Force at level 7. The Navigator device writes a Service Force which is level 3. System Pilot and Touch Pilot devices write Supervisor Forces at level 4. Network programs can be set to write different level priority forces.

NOTE: In the case of a control power reset, any force in effect at the time of power reset will be cleared.

IMPORTANT: All further discussions and examples in this document will be based on the SystemVu controller.

START-UP

IMPORTANT: Do not attempt to start unit, even momentarily, until all items on the Start-Up Checklist (see CL-1, CL-2) and the following steps have been read/completed.

Unit Preparation

Check that unit has been installed in accordance with these installation instructions and all applicable codes. See Fig. 6-9 for panel locations.

Refrigerant Service Ports

The refrigerant system has a total of 3 Schrader-type service gage ports per circuit. One port is located on the suction line, one on the compressor discharge line, and one on the liquid line. Be sure that caps on the ports are tight.

Crankcase Heater

The compressor is equipped with a crankcase heater. There is a control function used to turn the crankcase heaters on and off when the compressor is not running. This is a configurable value for which the factory default value is set to 65°F. If the ambient is above the selected value, the control will prevent the crankcase heater from turning on.

IMPORTANT: Unit power must be on for 24 hours prior to start-up to allow the crankcase heater to run. Otherwise, damage to the compressor may result.

Compressor Rotation

⚠ CAUTION

UNIT DAMAGE HAZARD

Failure to follow this caution may result in unit damage.

Improper wiring will cause compressor stoppage and alarm. Correct wiring by switching leads as indicated in the following section.

On 3-phase units, it is important to be certain the compressors are rotating in the proper direction. To determine whether or not compressors are rotating in the proper direction, use a phase-rotation meter on the unit input power to check for L1-L2-L3 or clockwise rotation or use the Service Test mode to energize a compressor. If the compressor is rotating in the wrong direction, the controls will stop the compressor and display alarm for "Circuit A Reverse Rotation".

NOTE: Indoor or outdoor fan rotation direction may not indicate proper input power phase sequence, as some 3-phase units use single-phase fan motors.

To correct the wrong compressor rotation direction, perform the following procedure:

1. Turn off power to the unit and lock out the power.
2. Switch any two of the incoming unit power leads.
3. Turn on power to the unit.
4. Verify corrected compressor rotation.

Power Supply

All 208/230-v units are factory wired for 230-v power supply. If the 208/230-v unit is to be connected to a 208-v power supply, the transformers must be rewired by moving the wire from the 230-volt connection and moving to the 200-volt terminal on the primary side of the transformer. Refer to unit label diagram for additional information.

Internal Wiring

Check all electrical connections in unit control boxes; tighten as required.

Evaporator Fan

The evaporator fan should be checked and may need to be adjusted or specific applications. The unit will have a belt drive motor powered by a Variable Frequency Drive (VFD). Refer to the unit product data for fan performance tables and physical data.

The fan belt and variable pulleys are factory installed and set, but may need to be adjusted for specific applications. Check the fan to ensure its rotation is in the proper direction before adjusting performance. To alter fan performance, first adjust the pulley settings to provide the application's full load design air flow when running at the IDF Maximum Fan Speed (**MAXIMUM IDF SPEED**). The unit operating speeds can then be adjusted with Free Cooling IDF Speed (**FREE COOL IDF SPEED**), High Cooling IDF Speed (**HIGH COOL IDF SPEED**), Medium Cooling IDF Speed (**MED COOL IDF SPEED**), Low Cooling IDF Speed (**LOW COOL IDF SPEED**), Heating IDF Speed (**HEATING IDF SPEED**), and Ventilation Only IDF Speed (**VENT IDF SPEED**). Set the indoor fan pulley to the greater application design point CFM for heating or cooling and equal to 100% fan speed. Adjust the Heating Fan Speed and High Cooling Fan Speed so that the CFM is not lower than the minimum CFM allowed in the product data. If the exact CFM cannot be set by the half turn pulley settings then adjust the IDF Maximum Fan Speed

(**MAXIMUM IDF SPEED**) to fine tune the CFM to the application requirements. The VFD's settings should not be used for adjusting fan performance. Specific VFD information can be found in the major components section.

IMPORTANT: The IDF Maximum Fan Speed (**MAXIMUM IDF SPEED**) RPM must not produce a supply CFM that is lower than the minimum CFM allowed in the product data for heating and cooling.

Condenser Fans and Motors

Condenser fans and motors are factory set.

Return-Air Filters

Check that correct filters are installed in filter tracks (see physical data table in unit product data). Do not operate unit without return-air filters. Determine the filter change run time (**DIRTY FILTER TIME**) to be set in the quick setup configurations menu.

Outdoor-Air Inlet Screens

Outdoor-air inlet screens must be in place before operating unit.

Accessory Installation

Check to make sure that all accessories including space thermostats and sensors have been installed and wired as required by the instructions and unit wiring diagrams.

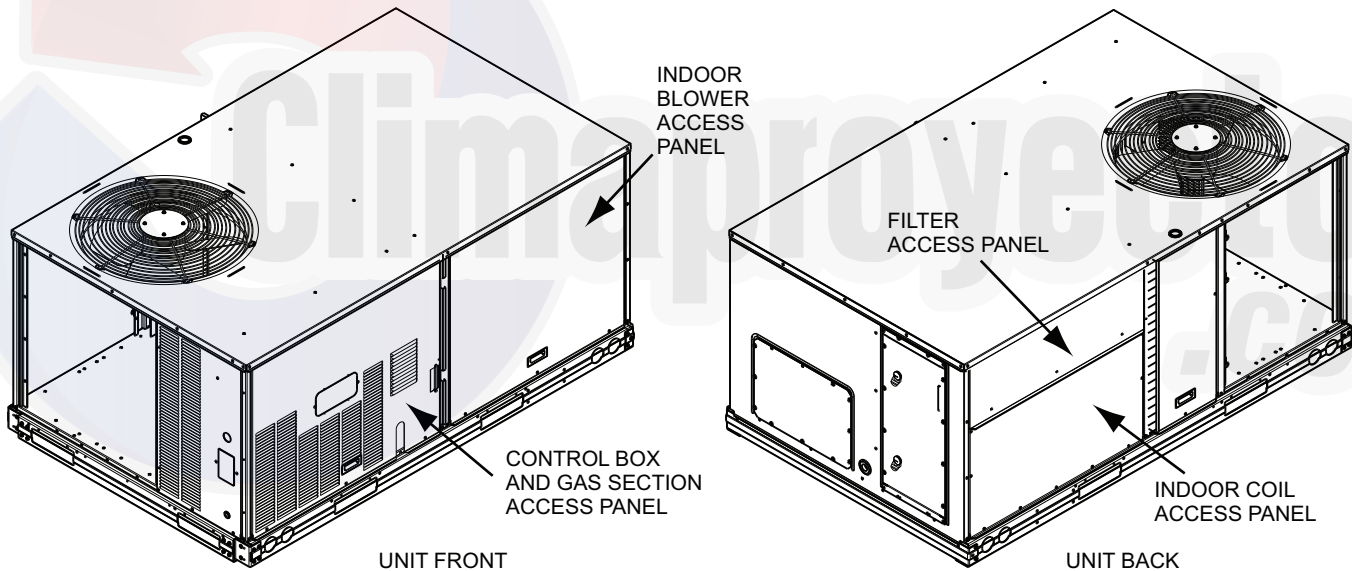

Fig. 6 — 48/50LC Size 04-06 Units – Panel and Filter Locations (48LC*04 Unit Shown)

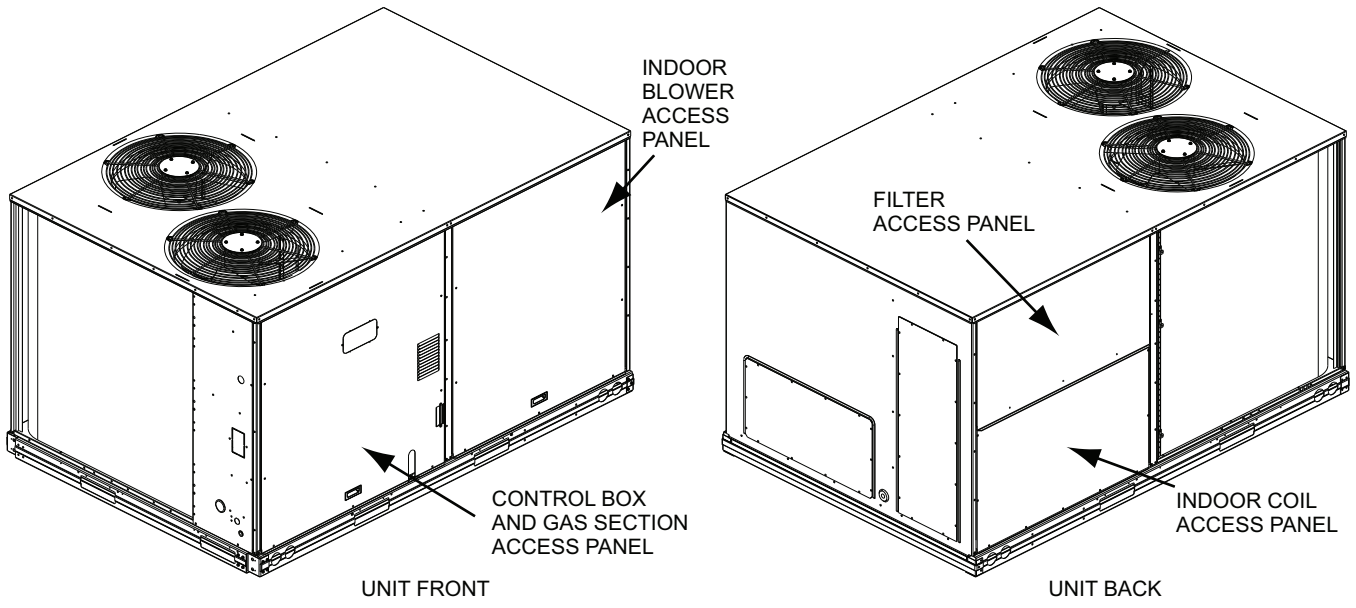

Fig. 7 — 48/50LC Size 07 Units – Panel and Filter Locations (48LC*07 Unit Shown)

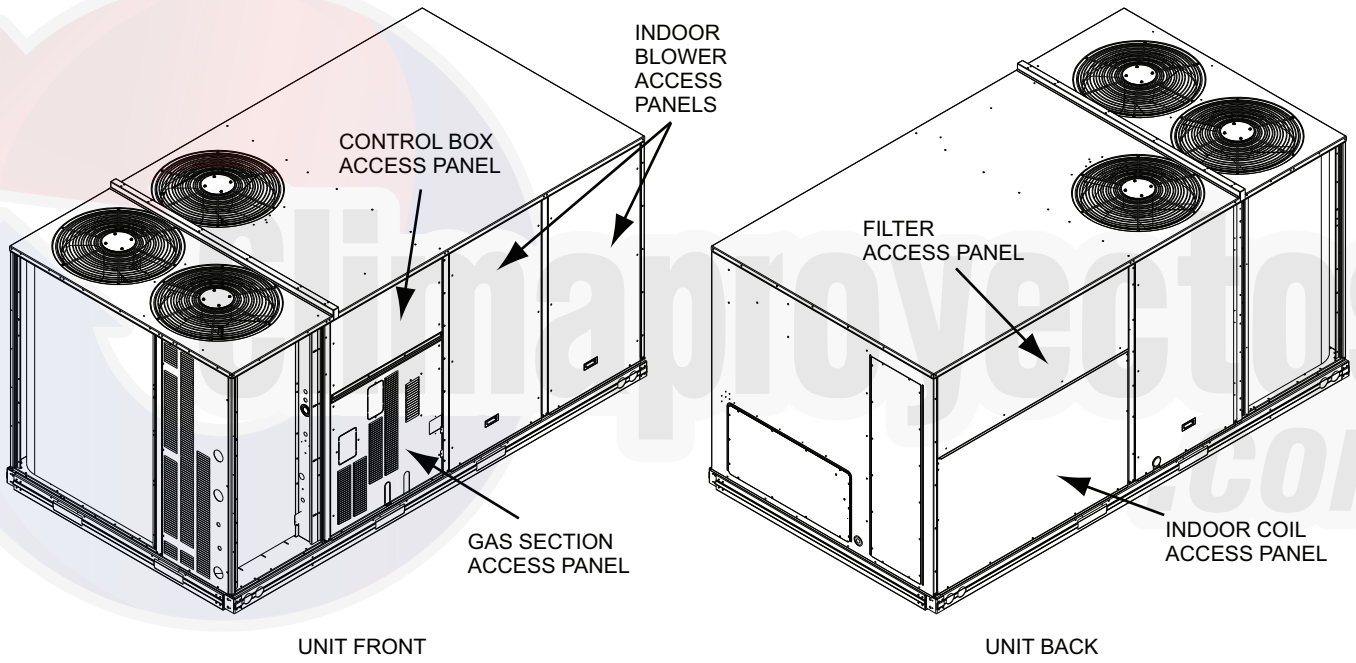

Fig. 8 — 48/50LC Size 08-12 Units – Panel and Filter Locations (48LC*09 Unit Shown)

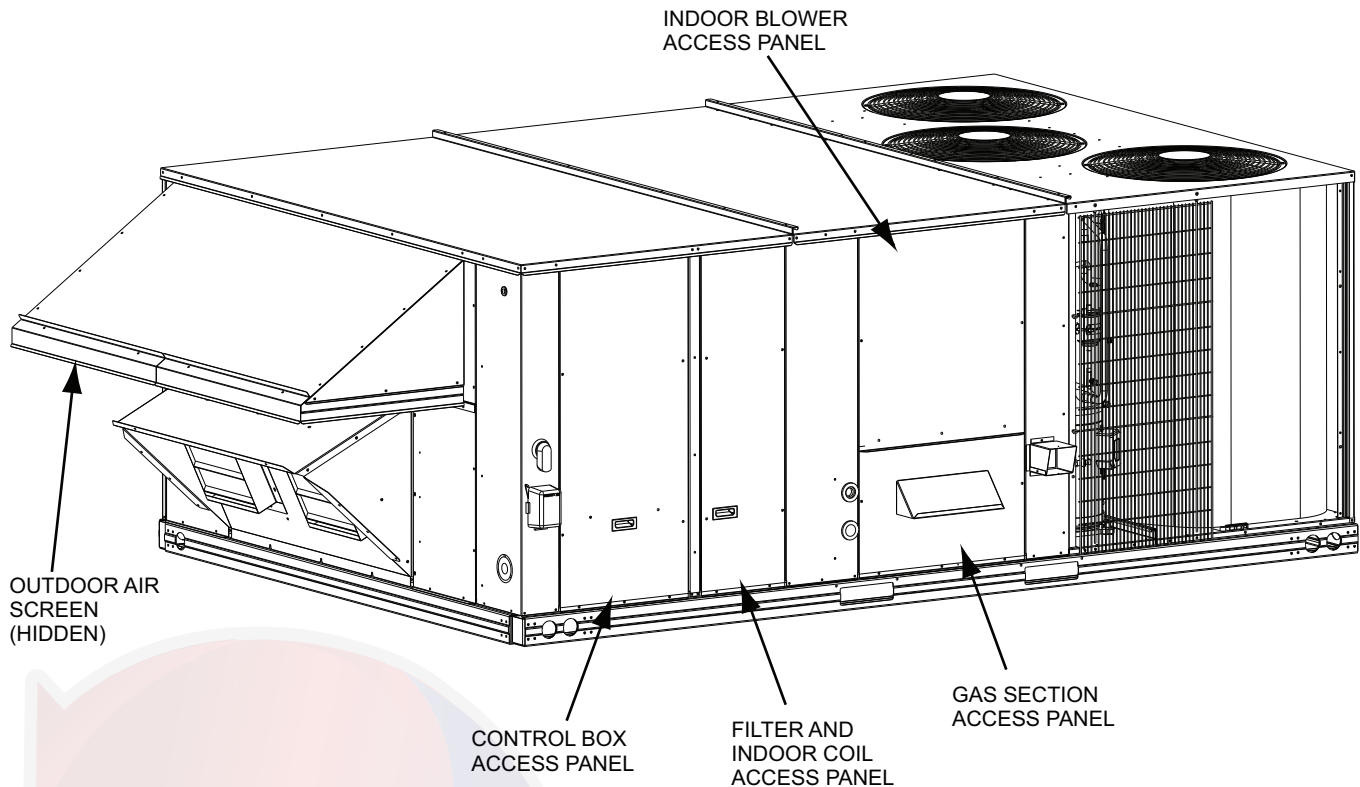

Fig. 9 — 48/50LC Size 14-26 Units – Panel and Filter Locations (48LC*14 Unit Shown)

Gas Heat (48LC units only)

Inspect the gas heat section of the unit. Verify the number of burners match the number of heat exchanger openings and the burner assembly is properly aligned. If the orifices were changed out for elevation or liquid propane purposes, verify proper installation. Visually inspect other components in heat section.

Verify gas pressures before turning on heat as follows:

1. Close the field-supplied manual gas shut off valve, located external to the unit.
2. Connect a pressure gage to the supply gas pressure tap, located on the field-supplied manual gas shut off valve (see Fig. 10).
3. Connect a pressure gage to the manifold pressure tap on the burner assembly located inside the unit.
4. Open the field-supplied manual gas shut off valve. Enter Service Test mode by setting TEST MODE to “ON” using the SystemVu™ controller interface. Use the Service Test feature to set HEAT 1 TEST to ON (first stage of heat) using the SystemVu controller interface.
5. After the unit has run for several minutes, verify the supply gas pressure is adequate per the base unit installation instructions. If not, adjust accordingly.

NOTE: Supply gas pressure must not exceed 13.0 in. wg.

6. Set HEAT 1 TEST to OFF using the SystemVu controller interface.
7. Exit Service Test mode by setting TEST MODE to “OFF” using the SystemVu controller interface.

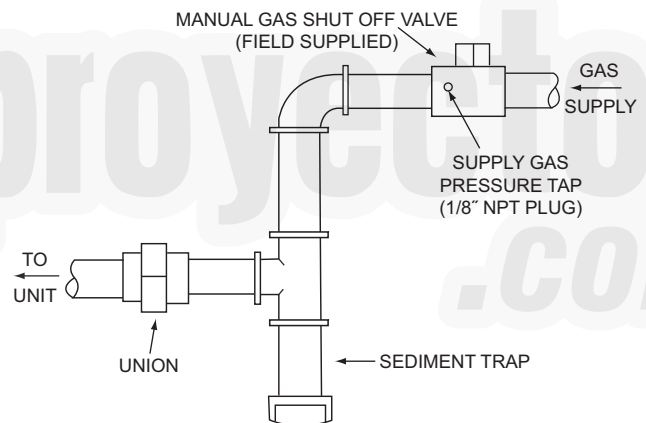

Fig. 10 — Field Gas Piping

CONTROLS QUICK SET-UP

The following information will provide a quick guide to setting up and configuring the 48/50LC series units with SystemVu controls. Unit controls are pre-configured at the factory for factory-installed options. Field-installed accessories will require configuration at start-up. Initial System Startup is recommended for initial start-up. Additionally, specific job requirements may require changes to default configuration values. See Appendix A and other sections of these instructions for more details. Refer to the Major System Components or accessory installation instructions for specific wiring detail.

Control Set Point and Configuration Log

During start up, accessory installation, and equipment service set points and/or configuration changes might have to be made. When setting set points or configuration settings, documentation is recommended. The Control Set Point and Configuration Log starting on page 174 should be filled out and left with the unit at all times, and a copy should also be provided to the equipment

owner. A USB jump drive can be used to back up the unit's configurations. Refer to the USB Operation section for details.

Initial Startup

Initial Startup refers to the first time this particular unit has a startup performed. The SystemVu controller will continually display the Initial Startup prompt until it is completed. To complete the initial startup you must complete the Quick Setup, Network Setup, and the System Auto Test.

QUICK SETUP

This is a list of common adjusted configurations set during startup. These are common accessories and control means. See the list in Table 3. After setting these per the specific unit, set the QUICK SET CHKLIST point to done.

Table 3 — Quick Setup Menu Items

SYSTEMVU™ DISPLAY	EXPANDED NAME	RANGE	DEFAULT
QUICK SETUP CONFIG	QUICK SETUP CONFIG MENU		
TIME	Clock Hour and Minute	HH:MM	
DATE	Current Date	MM/DD/YYYY	
STARTUP DELAY	Unit Startup Delay	10 to 600	30
UNIT CONTROL TYPE	Unit Control Type	0=TSTAT, 1=SPACE SEN, 2=RAT SEN	0
THERMOSTAT TYPE	Thermostat Hardware Type	0=CONV 2C2H, 1=DIGI 2C2H, 2=CONV 3C2H, 3=DIGI 3C2H	2
DIRTY FILTER TIME	Change Filter Timer	0 to 9999	600
VENT IDF SPEED	Ventilation Only IDF Speed	0 to 100	67*
HEATING STAG QTY	Number of Heating Stages	1 to 2	2*
ECON INSTALLED?	Economizer Installed?	No/Yes	No*
FREECOOL MAX OAT	Free Cooling Max OAT	0 to 90	65
FIRE SHUTDOWN SW	Fire Shutdown Switch	0=No Switch, 1=N/Open 2=N/Close	0*
QUICK SET CHKLIST	QUICK SETUP CHECKLIST	0=Undone, 1=View, 2=Done	0

*These defaults change based on the unit model number.

NETWORK SETUP

This is a shortcut to the Network Settings submenu. In this submenu are the specific network settings required to get the network piece up and running. After setting these per the specific unit, set the NETWORK CHKLIST point to done.

SYSTEM AUTO TEST

Turning this to Start will run enable test mode and execute the System Auto Test. After the auto test has completed, set this to done.

Thermostat Control

Wire accessory thermostat to the corresponding R, Y1, Y2, Y3, W1, W2, and G terminals on the Main Base board.

The Unit Control Type configuration, (UNIT CONTROL TYPE) default value is for thermostat (0) so there is no need to configure this item.

The Thermostat Hardware Type, (THERMOSTAT TYPE) selects the unit response to the thermostat inputs above.

NOTE: May not be compatible with heat anticipator thermostats.

Space Temperature Sensor Control - Direct Wired (T-55 or T-56 or T-59)

Wire accessory space temperature sensor(s) to the T-55 terminals on the field connection terminal board located at the unit control box. Refer to Space Mounted Sensors section (page 71) for additional information.

The Unit Control Type configuration, (UNIT CONTROL TYPE) must be set to Space Sensor (1).

Space Humidistat Control

For units with the factory-installed Humidi-MiZer® system option, the humidistat input is provided with quick connects. The Space Humidity Switch configuration, **SETTINGS** → **UNIT CONFIGURATIONS** → **SWITCH INPUTS CONFIGS** → **HUMSTAT CHANNEL** identifies the normally open or normally closed status of this input at HIGH humidity.

Relative Humidity Sensor Control

For units with the factory-installed Humidi-MiZer system option, the humidity sensor input is provided with quick connects. The sensor can be used instead of a humidistat. The RH Sensor configuration, **SETTINGS** → **UNIT CONFIGURATIONS** → **ANALOG INPUTS CONFIGS** → **SPRH SENSOR CHANNEL**, identifies the point on the MBB (Main Base board) or the IOB (Input Output board) the sensor was wired into.

CCN Communication

First configure the building protocol **SETTINGS** → **NETWORK SETTINGS** → **BAS PROTOCOL to CCN** (default is 0 = NONE). Configure the following under the CCN menu (**SETTINGS** → **NETWORK SETTINGS** → **CCN**).

CCN ELEMENT # — Default is 1

BUS NUMBER — Default is 0

CCN BAUDRATE — Default is 2 = 38400

CCN Linkage Control

The CCN communication must be properly configured for the 48/50LC units and all other devices. Linkage configuration is automatically done by the supervisory CCN Linkage device.

The unit control type configuration, (UNIT CONTROL TYPE) must be set to space sensor (1).

Installation of an accessory supply air temperature (SAT) sensor on the fan deck near the corner post is recommended for Linkage applications. The SAT heat mode sensing configuration (**SAT DURING HEAT?**) will be enabled at the factory.

System Pilot™ – Communication Space Sensor

Install the System Pilot device and connect the CCN communication bus from it to the unit's CCN connection on TB4 - BAS connector of the Main Base Board (MBB). Configure the unit's CCN communication element number, bus number, and baud rate. Refer to the System Pilot's installation instructions for configuring it to be used as a space temperature and attaching it to a unit.

SystemVu™ Controller

The SystemVu controller will support the use of i-Vu® compatible ZS sensors and either Equipment Touch™ or System Touch™ when the Network Protocol is BACnet. **SETTINGS** → **NETWORK SETTINGS** → **BAS PROTOCOL**.

Accessories

Below are quick configuration settings for field-installed accessories. When factory-installed as options, the points will already be configured. See the Space Mounted Sensors section (page 71), third party control, control connection tables, and CCN or Display parameter tables for any accessories not mentioned below and refer to installation manual of the accessory.

ECONOMIZER

When an economizer is field-installed, the unit must be configured for it by setting **SETTINGS** → **UNIT CONFIGURATIONS** → **ECONOMIZER** → **ECON INSTALLED?** to YES. The default settings for the other economizer configurations should be satisfactory. If they need to be changed, additional information about these configuration settings can be found in “Economizer Operation” on page 27.

POWER EXHAUST

When power exhaust is field-installed, the unit must be configured for it by setting **SETTINGS** → **UNIT CONFIGURATIONS** → **ECONOMIZER** → **POWER EXHAUST CONFIGS** → **PE1 RELAY CHANNEL** to the channel the accessory was wired into. The default settings for the other power exhaust configurations should be satisfactory. If they need to be changed, additional information about these configurations can be found in “Power Exhaust” on page 29.

ELECTRIC HEAT

When electric heat is field-installed, the number of electric heat stages must be configured by setting **SETTINGS** → **UNIT CONFIGURATIONS** → **HEATING** → **HEATING STAGE QTY** per the installed heater.

FIRE SHUTDOWN

When Fire Shutdown or Smoke Detector sensors are field-installed, the unit must be configured for it by setting **SETTINGS** → **UNIT CONFIGURATIONS** → **SWITCH INPUTS CONFIGS** → **FIRE SHUTDOWN SW** to normally open (0) or normally closed (1).

OUTDOOR ENTHALPY

When an Outdoor Enthalpy sensor is field-installed, the unit must be configured for it by setting **SETTINGS** → **UNIT CONFIGURATIONS** → **ANALOG INPUTS CONFIGS** → **OARH SENSOR CHAN** to the channel number the sensor was wired into.

IAQ SENSOR

When a CO₂ sensor is field-installed, the unit must be configured for it by setting **SETTINGS** → **UNIT CONFIGURATIONS** → **ANALOG INPUT CONFIGS** → **IAQ SENSOR CHAN** selects the unit response to this input. Default conversion to 0 to 2000 ppm.

OAQ SENSOR

When an Outdoor Air Quality sensor is field-installed, the unit must be configured for it by setting **SETTINGS** → **UNIT CONFIGURATIONS** → **ANALOG INPUT CONFIGS** → **OAQ SENSOR CHAN**. Default conversion to 0 to 2000 ppm.

FILTER STATUS

When a Filter Status sensor is field-installed, the unit must be configured for it by setting **SETTINGS** → **UNIT CONFIGURATIONS** → **SWITCH INPUT CONFIGS** → **FILTER SW CHANNEL** to normally open (0) or normally closed (1).

Programming Operating Schedules

When the building automation system you have the SystemVu™ controller configured for (**BAS Protocol Select**) is None (0) or CCN (1) the SystemVu controller can follow a standard CCN occupancy table. The occupancy can be modified from any CCN tool or from the local display.

OCCUPANCY SCHEDULE

For flexibility of scheduling, the occupancy programming is broken into eight separate periods. For each period the schedule contains the following fields: **Day of Week**, **Occupied From**, and **Occupied To**.

When the Network protocol as configured in **SETTINGS** → **NETWORK SETTINGS** → **BAS PROTOCOL** is BACnet, the

controller will support a BACnet weekly schedule and all types of override and exception schedules allowed for BACnet level 12 compliance. SystemVu will also support a special i-Vu type of BACnet schedule sent from i-Vu or WebCTRL. Please refer to the iVu operator’s manual for more information.

Day Of Week

The day of week configuration consists of eight fields corresponding to the seven days of the week and a holiday field in the following order: Monday, Tuesday, Wednesday, Thursday, Friday, Saturday, Sunday, and Holiday. If a 1 is configured in the corresponding place for a certain day of the week, the related “Occupied from” and “Occupied to” times for that period will take effect on that day of the week. If a 1 is placed in the holiday field, the related times will take effect on a day configured as a holiday. A zero means the schedule period will not apply to that day.

Day of week: Range 0 or 1

Default Values 0 for all of the periods.

Occupied From

This field is used to configure the hour and minute, in 24 hour clock, that the mode for the controller will switch to occupied.

Occupied From: Units Hours:Minutes

Range 00:00 to 24:00

(Minutes 00 to 59)

Default Value 00:00

Occupied To

This field is used to configure the hour and minute, in 24 hour clock, that the mode for the controller switches from occupied to unoccupied.

Occupied To: Units Hours:Minutes

Range 00:00 to 24:00

(Minutes 00 to 59)

Default Value 00:00

When the building automation system configured to (**BAS PROTOCOL**) is BACnet, the occupancy and holiday information will be reset to defaults in preparation for receiving a BACnet occupancy object. While participating on a BACnet network these configurations cannot be changed at the local interface or with CCN tools. All scheduling is done from the BACnet interface designated to provide schedules.

SERVICE TEST

The Service Test function can be used to verify proper operation of compressors, heating stages, indoor fan, outdoor fans, Humidi-MiZer® system operation, power exhaust fans, economizer, crankcase heaters, and the alarm relay. Use of Service Test is recommended at initial system start up and during troubleshooting. (See Table 4 for point details)

Service Test mode has the following changes from normal operation:

- Outdoor air temperature limits for cooling circuits, economizer, and heating are ignored.
- Normal compressor time guards and other staging delays are reduced to one minute or less.
- Circuit strike out time is reduced to 1 minute instead of 15 minutes.
- It may take up to 30 seconds to actually enter test mode after activating the command.

Table 4 — Test Mode Unit Test Directory

DISPLAY MENU / SUBMENU / NAME	EXPANDED NAME	VALUES
SERVICE	Service Menu	
UNIT TESTS	Unit Tests Menu	
TEST MODE	Service Test Mode Enable	On/Off
SERVICE TEST	Service Test Menu	
INDEPENDENTS	INDEPENDENT TEST MENU	
ECON POS TEST	Economizer Position Test	0 to 100
BUMP COMP A1 TEST	Compressor Bump A1 Test	On/Off
BUMP COMP A2 TEST	Compressor Bump A2 Test	On/Off
LIQ DV VALVE TEST	Liq Diverter Val Rly Tst	On/Off
RH DIS VALVE TEST	Rht Dischg Valve Rly Tst	On/Off
RH LIQ VALVE TEST	Reheat Liq Valv Rly Test	On/Off
CL LIQ VALVE TEST	Cooling Liq Valv Test	On/Off
CCH RELAY 1 TEST	Crankcase Heater 1 test	On/Off
ALARM RELAY TEST	Alarm Output Relay Test	On/Off
PE1 RELAY TEST	Power Exhaust 1 Test	On/Off
PE2 RELAY TEST	Power Exhaust 2 Test	On/Off
FAN TESTS	Indoor and Outdoor Fan tests Menu	
IDF SPEED TEST	Indoor Fan Speed Test	0 to 100
ALL ODF SPD TEST	System ODF Speed Test	0 to 1200
ODF 1 SPEED TEST	Outdoor Fan 1 speed test	0 to 1200
ODF 2 SPEED TEST	Outdoor Fan 2 speed test	0 to 1200
ODF 3 SPEED TEST	Outdoor Fan 3 speed test	0 to 1200
IDF MANUAL TRANS	IDF Manual Transition	Yes/No
ODF MANUAL TRANS	ODF Manual Transition	Yes/No
COOL TESTS	Cooling Test Menu	
COOL A1 TEST	Cooling W/Comp.A1 Test	On/Off
COOL A2 TEST	Cooling W/Comp.A2 Test	On/Off
COOL ALD TEST	Cooling W/Comp.ALD Test	On/Off
IDF SPEED TEST	Indoor Fan Speed Test	0 to 100
ALL ODF SPD TEST	System ODF Speed Test	0 to 2000
HUMIDIMIZER TEST	Humidi-MiZer Level Test	0 = Off 1 = Subcool 2 = Reheat
HEAT TESTS	Heating Test Menu	
HEAT 1 TEST	Heating Stage 1 Test	On/Off
HEAT 2 TEST	Heating Stage 2 Test	On/Off
IDF SPEED TEST	Indoor Fan Speed Test	0 to 100
AUTOMATIC TEST	Automatic Test Menu	
AUTO INDP TEST	Auto Independent Test	Yes/No
AUTO COOL TEST	Run Auto Cooling Test	Yes/No
AUTO HEAT TEST	Run Auto Heating Test	Yes/No
AUTO SYSTEM TEST	Run Auto System Test	Yes/No

Press the TEST button on the SystemVu™ interface anytime to access the Test menu. Service Test mode can only be turned ON/OFF at the unit display. Once turned ON, other entries may be made with the display or through CCN. To turn Service Test mode on, change the value of TEST MODE to ON. To turn service test mode off, change the value of TEST MODE to OFF. Service Test mode will be automatically turned off based on keypad inactivity and the Service Mode Test Time out (**TEST MODE TIMEOUT**).

NOTE: Service Test mode may be password protected. Refer to Basic Control Usage section for more information. Depending on the unit model, factory-installed options, and field-installed accessories, some of the Service Test functions may not apply.

Independent Outputs

The **INDEPENDENTS** submenu is used to change output status for the economizer, Humidi-MiZer® system valves, power exhaust stages, crankcase heaters, the alarm relay, as well as perform a compressor bump test. These independent outputs can operate simultaneously with other Service Test modes. All outputs return to normal operation when Service Test is turned off. The compressor bump tests cannot be run while running cooling tests and will automatically turn off after one minute.

Fan Test

The **FAN TESTS** submenu is used to change speed for the indoor fan and outdoor fans. The outdoor fan speeds can be controlled individually or all together with the **ALL ODF SPD TEST**. The outdoor fan and indoor fan transition type points inform the test routine how to handle the fans while running the cooling or heating tests. Automatic will automatically transition the fans as the cooling or heating tests change, while the Manual transition will only run the fans as set by the test points.

Cooling Test

The **COOL** submenu is used to change output status for the individual compressors and Humidi-MiZer system operation. The **HEAT** submenu service test outputs are reset to OFF for the cooling service test. Indoor fans and outdoor fans are controlled normally to maintain proper unit operation when set for automatic transition. The **IDF SPEED TEST** and **ALL ODF-SPD TEST** can be changed as needed for testing. These fan points show the requested speed, not actual speed. All normal cooling faults and alerts are functional.

Heating Test

The **HEAT** submenu is used to change output status for the individual heat stages, gas or electric. The **COOL** service test outputs are reset to OFF for the heating service test. Indoor fan is controlled normally to maintain proper unit operation when set for automatic transition. The **IDF SPEED TEST** can be changed as needed for testing and shows the requested speed not actual speed. All normal heating faults and alerts are functional.

NOTE: When the IGC fan on command (**IGC FAN REQUEST**) is active, the fan may run when not expected.

Automatic Test

The **AUTOMATIC TEST** submenu is used to execute all the applicable tests to the system automatically. These include independent component, cooling, heating, and a system one. Table 5 shows the steps taken during the independent, cooling, and heating automatic tests. The Hold time represents the time at which that control waits before moving on to the next step. The AUTO SYSTEM TEST will execute the independent auto test, then the cooling auto test, then the heating auto test. At the end of the system auto test a prompt will ask if you want to enter measured data and complete a service report.

Table 5 — Independent, Cooling, and Heating Automatic Tests

AUTO INDP TEST		
Step	Action	Hold (Sec)
1	Turn on Crankcase Heater Relay	0
2	Set ODF1 to the High Cool Speed	30
3	Set ODF1 to the Minimum Speed	30
4	Turn ODF1 off	5
5	Set ODF2 to the High Cool Speed	30
6	Set ODF2 to the Minimum Speed	30
7	Turn ODF2 off	5
8	Set ODF3 to the High Cool Speed	30
9	Set ODF3 to the Minimum Speed	30
10	Turn ODF3 off	5
11	Set IDF speed to 100%	30
12	Set Economizer Damper to 100%	60
13	Turn on power exhaust 1	10
14	Turn on power exhaust 2	10
15	Set Economizer Damper to 0%	60
16	Turn off power exhaust 2	10
17	Turn off power exhaust 1	10
18	Set IDF to the ventilation speed	30
19	Turn on alarm relay	10
20	Turn off alarm relay	10
21	Set IDF to 0% speed	30
22	Turn off Crankcase Heater relay	0
AUTO COOL TEST		
Step	Action	Hold (Sec)
1	Set ODF auto transition	0
2	Set IDF auto transition	0
3	Turn on Cool A1 test	60
4	Turn off Cool A1 test	30
5	Turn on Cool A2 test	60
6	Turn on Cool A1 and Cool A2 tests	30
7	Turn off Cool A1 and Cool A2 tests	60
8	Turn on Reheat test	60
9	Switch to Subcool test	30
10	Turn off Subcool test	30
AUTO HEAT TEST		
Step	Action	Hold (Sec)
1	Set IDF auto transition	0
2	Turn on Heat 1 test	60
3	Turn on Heat 2 test	60
4	Turn off Heat 1 and Heat 2 tests	20

THIRD PARTY CONTROL

Third party controls may interface with the unit SystemVu™ controller through the connections described below. See other sections of these instructions for more information on the related unit control and configurations.

Cooling/Heating Control

The thermostat inputs are provided on TB1 of the board. The Unit Control Type configuration, **UNIT CONTROL TYPE**, must be 0 (Tstat) to recognize the below inputs. Terminal R is the 24 VAC source for the following:

- Y1 = first stage cooling
- Y2 = second stage cooling
- Y3 = third stage cooling
- W1 = first stage heating
- W2 = second stage heating
- G = Indoor fan

Dehumidification Control

On Humidi-MiZer® system units the HUMIDISTAT and SPRH leads are provided with quick connects. The Space Humidity Switch configuration, **SETTINGS** → **UNIT CONFIGURATIONS** → **SWITCH INPUTS CONFGS** → **HUMSTAT CHANNEL** identifies the normally open or normally closed status of this input at HIGH humidity. The RH Sensor configuration, **SETTINGS** → **UNIT CONFIGURATIONS** → **ANALOG INPUTS CONFGS** → **SPRH SENSOR CHANNEL**, identifies the point on the MBB (Main Base board) or the IOB (Input Output board) the sensor was wired into.

Remote Occupancy

The remote occupancy input can be provided on one of the configurable inputs, most commonly TB3. The Remote Occupancy Switch configuration, **REMOTE OCC TYPE**, identifies the normally open or normally closed status of this input when unoccupied. The Remote Occupancy Channel configuration, **REMOTE OCC CHAN**, identifies the discrete input (DI) assigned for this function.

Remote Shutdown

The remote shutdown input is provided for unit shutdown in response to switch input configured most commonly on TB3. The Remote Shutdown Switch configuration, **REM. SHUT-DOWN TYPE**, identifies the normally open or normally closed status of this input when there is no shutdown command. The Remote Shutdown Channel configuration, **REM. SHUT-DOWN CHAN**, identifies the discrete input (DI) assigned for this function.

Alarm Output

The alarm output is provided on as a configurable relay, most commonly on TB2, to indicate when a current alarm is active. The output will be 24 VAC if a current alarm exists. The Alarm Relay Channel configuration, **ALM RELY CHANNEL**, identifies the discrete output (DO) assigned for this function.

Economizer Damper Control

For units with the economizer option or accessory, the damper position can be directly controlled through the IAQ sensor input. The IAQ Analog Input configuration, **IAQ LEVEL CONTROL** will have to set to 2 (CTL MINP). When IA.CF = 2, an external 4 to 20 mA source is used to move the damper 0% to 100% directly.

CONTROLS OPERATION

Display Configuration

The **SETTINGS** → **DISPLAY SETTINGS** submenu is used to configure the local display settings.

METRIC DISPLAY

This variable is used to change the display from English units to Metric units.

LANGUAGE

This variable is used to change the language of the SystemVu display. At this time, only English is available.

CONTRAST ADJUST

This is used to adjust the contrast of the SystemVu display.

PASSWORD ENABLE?

This variable enables or disables the use of a user password. The password is used to restrict use of the control to change configurations.

VIEW USER PASSWORD

This menu allows the user to view the user password. The password must be entered or disabled to view it.

CHANGE USER PASSWORD

This menu allows the user to change the user password. The password must be entered or disabled to change it.

Unit Configuration

Many configurations that indicate what factory options and/or field accessories are installed and other common operation variables are included in **SETTINGS** → **UNIT CONFIGURATION** submenu. Some of these configurations will be set in the factory for the factory-installed options (FIOPs). Field installed accessories and custom control functions will require configuration changes. The **SETTINGS** → **UNIT CONFIGURATION** → **GENERAL** submenu contains the following control configurations. Refer to other specific sections for other configurations.

STARTUP DELAY

This configuration sets the control start-up delay after the power is interrupted. This can be used to stagger the start-up of multiple units.

UNIT CONTROL TYPE

This configuration defines if temperature control is based on thermostat inputs or space temperature sensor input. TSTAT value is when then unit determines cooling and heating demand by the state of G, Y1, Y2, W1, and W2 inputs from a space thermostat. This value is the factory default. SPACE SEN value is when the unit determines cooling and heating demand based on the space temperature and the appropriate set point. RAT SEN value is when the unit determines cooling and heating demand based on the return air temperature and the appropriate set point. SPACE SEN or RAT SEN are also used as Linkage configuration.

THERMOSTAT TYPE

This configuration applies only if Unit Control Type is Thermostat. The value determines how the inputs are interpreted. See the specific operation sections for more information. The following descriptions define what each value means.

0 = CONV 2C2H – Conventional Thermostat 2 stage cool and 2 stage heat.

1 = DIGI 2C2H – Digital Thermostat 2 stage cool and 2 stage heat.

2 = CONV 3C2H – Conventional Thermostat 3 stage cool and 2 stage heat. This is the default setting.

3 = DIGI 3C2H – Digital Thermostat 3 stage cool and 2 stage heat.

ADAPTIVE TSTAT

This configuration applies only if the unit control type is Thermostat. When this is YES, the control will use Adaptive Control for cooling and heating staging. When this is set to NO, the control will use the Traditional Thermostat Control; however, during integrated cooling, Adaptive is always used.

DIRTY FILTER TIME

This configuration defines the life of the installed filter. A timer will count down from this number while the indoor fan is running. At the expiration of this timer, an alert will be activated to indicate a filter change is required.

TEST MODE TIMEOUT

This configuration defines the time at which a test mode test has not changed state will automatically disable test mode. This configuration will disable the timeout when set to 0 (Disabled).

CCH MAX TEMP

This configuration defines the temperature threshold for which the crankcase heater is no longer required to heat the compressor shell.

STD BARO PRESSURE

This configuration is used to specify the job location's standard barometer pressure reading. This will feed the BAROMETRIC

PRESS when a network is not writing to it. This should be used to account for job site elevation if enthalpy calculations are being used.

LINK STAGEUP TIME

This configuration sets the cooling and heating stage up time during linkage operation.

CONFIGURABLE SWITCHES AND ANALOG SENSORS

The SystemVu™ controller has optional configurable inputs. These consist of five physical board switch inputs (discrete inputs) and three physical board analog inputs. There are more functions allowed for configuration than there are inputs. Each function will have a configuration for which input channel it is assigned to. Each switch function will also have a switch type configuration which defines that switches normal state. Table 6 shows the configurable functions and what their normal and active states are. Table 7 shows the configurable analog input functions. The switch configurations can be found in the **SETTINGS** → **UNIT CONFIGURATIONS** → **SWITCH INPUT CONFIGS** sub-menu. The analog input configurations can be found in the **SETTING** → **UNIT CONFIGURATIONS** → **SWITCH INPUT CONFIGS** sub-menu. The configurable input assignment can be viewed in the **SERVICE** → **HARDWARE** → **ASSIGNED INPUTS/OUTPUTS** sub-menu.

Table 6 — Configurable Switch Input Functions

FUNCTION DESCRIPTION	NORMAL STATE	ACTIVE STATE
Humidistat	OFF	ON
Condensate Overflow	LOW	HIGH
Filter Status Switch	CLEAN	DIRTY
Remote Occupancy	UNOCC	OCCUPIED
Remote Shutdown	RUN	SHUTDOWN
General Status Switch	GOOD	ALARM
Enthalpy Switch Input	LOW	HIGH

Table 7 — Configurable Analog Input Functions

FUNCTION DESCRIPTION	SENSOR TYPE	SENSOR VALUES
Space Air Relative Humidity Sensor	0 to 20mA	%RH
Return Air Relative Humidity Sensor	0 to 20mA	%RH
Indoor Air CO ₂ Sensor	0 to 20mA	PPM
Outside Air CO ₂ Sensor	0 to 20mA	CFM

GENERAL OPERATION

48/50LC units can provide cooling, dehumidification, heating, and ventilation. The operating mode (MODE) shows the highest level of operation of the unit at any given time. The operating sub-mode (SUB-MODE) shows the detail operation occurring while under a specific mode. Table 8 shows the MODE and SUB-MODE values.

Each unit will operate under one of three basic types of control, thermostat, space temperature sensor, or return air temperature sensor. There are many inputs, configurations, safety factors, and conditions that ultimately control the unit. Refer to the specific operation sections for detail on a specific unit operation. The control will set the demand based on these types of control and conditions, which then drives the operating mode.

When thermostat control is enabled (**UNIT CONTROL TYPE**), the unit will operate based on discrete input commands (G, Y1, Y2, Y3, W1, and W2) and there is a one minute time delay between modes and when re-entering a mode. The G command calls for ventilation, the Y1, Y2, and Y3 commands call for cooling, and the W1 and W2 commands call for heating. Thermostat Control Type (**THERMOSTAT TYPE**) affects how cooling operates based on Y1, Y2, and Y3 commands and if cooling/heating stage time guards are applied.

When space temperature sensor control is enabled (*UNIT CONTROL TYPE*), the unit will try to maintain the Space Temperature (*SPACE TEMPERATURE*) between the effective cool and heat setpoints (*EFF COOL SETPOINT* and *EFF HEAT SETPOINT*). However, to minimize unnecessary cool to heat and heat to cool changes, there is a 10 minute delay after the last stage turns off before the control will switch modes. Linkage operation overrides the mode changeover delay to 15 seconds. The cooling and heating Mode Select Time guards (*COOL MODE T.GUARD* and *HEAT MODE T.GUARD*) show the remaining time before allowing the respective mode to be entered.

Demand Determination

Based on the unit control type (*UNIT CONTROL TYPE*), alarm conditions, and user interaction, the control will determine an overall demand of the unit. Table 9 shows the possible system demands with their priority level and summary description.

THERMOSTAT DEMAND

When the unit control type is configured for thermostat (*UNIT CONTROL TYPE = TSTAT*) the level 5 demand in Table 9 will be determined by thermostat inputs and the Thermostat Type configuration (*THERMOSTAT TYPE*) as shown in the tables below. Table 10 shows the cooling thermostat inputs and how they map to the system demand. Table 11 shows the heating thermostat inputs and how they map to the system demand.

Table 8 — Modes and Sub-Modes

MODE	OFF	VENT	COOL	HEAT	TEST
SUBMODES	STARTING UP	MODE TIMEGUARD	ECON FREE COOLING	HEATING	MANUAL TEST
	IDLE - NO DEMAND	SUPPLY FAN ON	UNOCC. FREE COOL	OUTSIDE AIR TEMPERING	AUTO TEST
	MODE TIMEGUARD		MECH. COOLING	HEATING PREVENTED	SHUTTING TEST OFF
	UNIT DISABLED		ECON/MECH COOLING	SHUTTING HEAT OFF	
	URGENT SHUTDOWN		DEHUMIDIFICATION		
	SAFETY CONTROL		DEHUM/MECH COOL		
			DEHUM PREVENTED		
			COOLING PREVENTED		
SHUTTING COOL OFF					

Table 9 — Demand List and Priority

DEMAND	PRIORITY	DESCRIPTION
EMERGENCY	1	An emergency condition occurs which requires a unit shutdown
SAFETY FAULT	2	A safety diagnostic requires the unit to run in safety mode
SERVICE TEST	3	User request test mode
SHUTDOWN	4	A minor or user condition requires the unit to shutdown
NO DEMAND	5	There is no comfort demand from the building
FAN ONLY		Only circulation or ventilation is requested from the building
DEHUM		A dehumidification load is present in the building
LOW COOL		A low cooling load is present in the building
MED COOL		A medium cooling load is present in the building
HIGH COOL		A high cooling load is present in the building
LOW COOL AND DEHUM		A low cooling and dehumidification load is present in the building
MED COOL AND DEHUM		A medium cooling and dehumidification load is present in the building
HIGH COOL AND DEHUM		A high cooling and dehumidification load is present in the building
UFC LOW COOL		A low cooling load is present in the building due to the unoccupied free cooling algorithm
UFC MED COOL		A medium cooling load is present in the building due to the unoccupied free cooling algorithm
UFC HIGH COOL		A high cooling load is present in the building due to the unoccupied free cooling algorithm
LOW HEAT		A low heating load is present in the building
HIGH HEAT		A high heating load is present in the building
SUPPLY AIR TEMPERING		Due to outside air, supply air is uncomfortably cool during ventilation

Table 10 — Thermostat Cooling System Demands

THERMOSTAT INPUTS			THERMOSTAT TYPE			
Y1	Y2	Y3	CONV 2C2H*	CONV 3C2H	DIGI 2C2H†	DIGI 3C2H
0	0	0	No Cool	No Cool	No Cool	No Cool
0	0	1	No Cool	Alert and Low Cool	No Cool	High Cool
0	1	0	Alert and Low Cool	Alert and Low Cool	Medium Cool	Medium Cool
0	1	1	Alert and Low Cool	Alert and Medium Cool	Medium Cool	High Cool
1	0	0	Low Cool	Low	Low Cool	Low Cool
1	0	1	Low Cool	Alert and Medium Cool	Low Cool	High Cool
1	1	0	High Cool	Medium Cool	High Cool	Medium Cool
1	1	1	High Cool	High Cool	High Cool	High Cool

*Set the *LOW COOL COMP* as needed, and Y3 is ignored.

†Y3 is ignored.

Table 11 — Thermostat Heating System Demands

THERMOSTAT INPUT		THERMOSTAT TYPE	
W1	W2	CONV 2C2H CONV 3C2H	DIGI 2C2H DIGI 3C2H
0	0	No Heat	No Heat
0	1	Alert and Low Heat	High Heat
1	0	Low Heat	Low Heat
1	1	High Heat	High Heat

SPACE SENSOR DEMAND

When the unit control type is configured for space sensor (*UNIT CONTROL TYPE = SPACE SEN*) the level 5 demand in Table 9 will be determined by the space sensor inputs and setpoints as described below. The Effective Demand Temperature (*DEMAND CTRL TEMP*) represents the temperature which the control is using to control the space. This would come from the space sensor, building network, linkage, or the return air sensor.

Setpoint Determination

Setpoints are used to control the unit. The Cool Setpoint in Effect (*EFF COOL SETPOINT*) and the Heat Setpoint in Effect (*EFF HEAT SETPOINT*) are the points which the unit is controlling to at a specific time. These points are read-only points and change according to occupancy, the offset slider status, and network writes. The setpoint configurations are in the *SETTINGS → SPACE SET POINTS* submenu.

If the building is in occupied mode, the Occupied Cool Setpoint (*OCC COOL SETPOINT*) and the Occupied Heat Setpoint (*OCC HEAT SETPOINT*) are active. When the building is in unoccupied mode, the Unoccupied Cool Setpoint (*UNOCC COOL SETPNT*) and the Unoccupied Heat Setpoint (*UNOCC HEAT SETPNT*) are active. The heating and cooling set points are also separated by a Heat-Cool Set Point Gap (*HEAT-COOL SP GAP*) that is user configurable from 2°F to 10°F. This parameter will not allow the setpoints to be set too close together; it will change the last setpoint adjusted if it is set within the GAP.

When the space sensor has a setpoint slider adjustment, the cool and heat setpoints (occupied) can be offset by sliding the bar from one side to the other. The SPT Offset Range (±) (*SPT SLIDER RANGE*) sets the total positive or negative degrees that can be added to the setpoints. With the slider in the middle, no offset is applied. Moving the slider to the “COOL” side will subtract from each setpoint, and sliding it to the “WARM” side will add to the setpoints. The slider offset being applied at any given time is displayed as Space Temperature Offset (*SLIDER OFFSET VAL*).

Temperature Demand

Space sensor staging control is an adaptive anticipation control that weighs the actual space demand against the trend of that demand. The control tries to anticipate the change in the space because of its current stage status. This anticipation is based on the demand trends. These trends will show the control how the space is reacting to the current running conditions and help it decide when to change the actual demand of the system. The following points are in the *RUN STATUS → MODE* submenu.

COOLING DEMAND

This is the difference between the Cool Setpoint in Effect (*EFF COOL SETPOINT*) and the Effective Demand Temperature (*DEMAND CTRL TEMP*) representing the demand of the space for cooling.

COOL DEMAND TREND

This is the rate of change of the cooling demand in degrees per minute, representing how the space is changing its demand for cooling.

HEATING DEMAND

This is the difference between the Heat Setpoint in Effect (*EFF HEAT SETPOINT*) and the Effective Demand

Temperature (*DEMAND CTRL TEMP*) representing the demand of the space for cooling.

HEAT DEMAND TREND

This is the rate of change of the heating demand in degrees per minute, representing how the space is changing its demand for cooling.

In general, the system demand will increase based on the demand compared to the demand switch states in Fig. 11. The demand cannot increase until Time Guard 1 (*DEMAND TIMEGUARD1*) expires. The LCON and LHON thresholds will also cause the system demand to be reduced. When the demand hits the off switch stages, the system demand will be set to NO DEMAND. These switch stages are in the *SETTINGS → SET POINTS → TEMP DEMAND CONFIG* submenu.

The cooling and heating demand level up configurations (*COOL DMD LEVEL UP* and *HEAT DMD LEVEL UP*) will restrict a system demand increase if the demand trend is less than the level up configuration. These level up configurations will also increase the system demand if the demand trend is greater than it for greater than the Time Guard 2 (*DEMAND TIMEGUARD2*).

The system demand will increase if it has remained at the same state for greater than Time Guard 3 (*DEMAND TIMEGUARD3*).

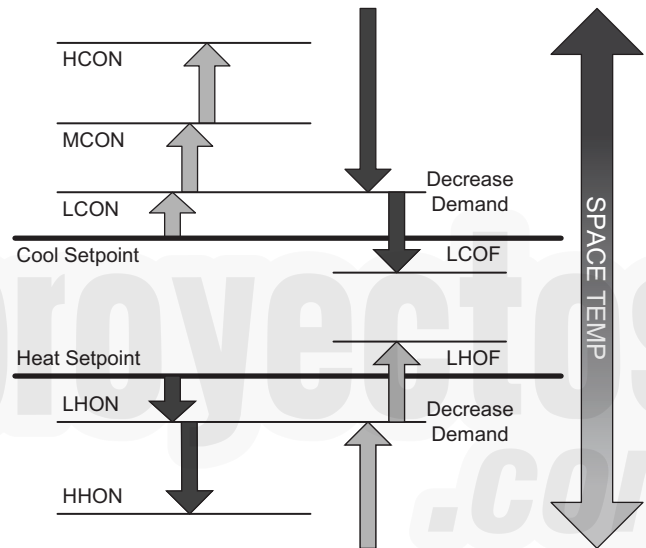

Fig. 11 — Space Sensor System Demand Switch States

RAT DEMAND

When the unit control type is configured for return air sensor (*UNIT CONTROL TYPE = RAT SEN*), the level 5 demand in Table 9 will be determined the same as space sensor but using the return air temperature (*RETURN AIR TEMP*) instead of the space temperature (*SPACE TEMPERATURE*).

Occupancy Determination

The building’s occupancy is affected by a number of different factors. Occupancy affects the unit set points and the operation of the economizer. The factors affecting occupancy are listed below from highest to lowest priority.

When Native BACnet is chosen as the Network communication method, *SETTINGS → NETWORK SETTINGS → BAS PROTOCOL = BACNET*, the Occupancy priorities will be adjusted to meet BACnet acceptable priorities. While in BACnet, there will be only one schedule (Schedule zero) and the CCN schedule data will be cleared out and placed under BACnet control. The Remote occupancy switch is still allowed for BACnet, while setting the schedule number to Zero for always occupied is not.

LEVEL 1 PRIORITY

Level 1 classification is a force/write to occupancy and can occur two ways. Listed in order of priority: force on OCCUPIED,

and a Linkage write. The CCN point OCCUPIED is forced via an external device such as a ComfortID™ controller or a service tool: when OCCUPIED is forced to YES, the unit is considered occupied, when OCCUPIED is forced to NO, the unit is considered unoccupied. If the unit is being controlled by Linkage, the occupancy is communicated and mapped to OCCUPIED as an input. Linkage does not force the point, only write to it, therefore a force applied to OCCUPIED will override it.

If OCCUPIED is not being forced or written to, proceed to the level 2 priority.

LEVEL 2 PRIORITY

Level 2 is considered occupant interaction, and consists of Timed Override and Remote Occupancy Switch. A timed override button press will override a remote occupancy switch if both are installed for operation.

While using the programmed schedule, occupancy can be temporarily switched from unoccupied to occupied by pressing the override button for approximately 3 seconds on the T-55, T-56, or T-59 space temperature sensor. The length of the override period when pressing the override button is determined by the Override Time Limit (**TIMED OVR LENGTH**). The hours remaining in override is displayed as Timed Override Hours (**TIMED OVR HOURS**). This point can also be changed from the local display or network to set or change the override period length.

Remote Occupancy Switch (**REMOTE OCC SWITCH**) can be forced or configured for operation based on an actual switch. The physical switch should be configured to either Normally Open or Normally Closed when the user would like to control the occupancy with an external switch. This switch is field-supplied (24v, single pole, single throw [SPST]). There are two possible configurations for the remote occupancy switch:

1. (**REMOTE OCC TYPE = 0**) Normally Open Switch
2. (**REMOTE OCC TYPE = 1**) Normally Closed Switch

If the switch is configured to No Switch (**REMOTE OCC CHAN = None**), the switch input value will be ignored and software will proceed to level 3 priority. For each type of switch, the appropriate configuration and states are listed in Table 12.

Table 12 — Switch Configurations

TYPE OF SWITCH	SWITCH CONFIGURATION	STATE OF SWITCH AND OF OCCUPANCY
Occupied when closed or Unoccupied when open	Normal Open (0)	Open and Unoccupied
		Closed and Occupied
Occupied when open or Unoccupied when closed	Normal Closed (1)	Open and Occupied
		Closed and Unoccupied

LEVEL 3 PRIORITY

The following occupancy options are determined by the state of Occupancy Schedule Number (**SCHEDULE NUMBER**) and the Global Schedule Broadcast (**BROADCAST SCHEDL?**).

1. (**SCHEDULE NUMBER = 0**) The unit is always considered occupied and the programmed schedule is ignored. This is the factory default.
2. (**SCHEDULE NUMBER = 1-64**) Follow the local programmed schedule. Schedules 1 to 64 are local within the controller. The unit can only store one local schedule and therefore changing this number only changes the title of the schedule table.
3. (**SCHEDULE NUMBER = 65-99**) Follow the global programmed schedule. If the unit is configured as a Global Schedule Broadcaster (**BROADCAST SCHEDL? = YES**), the unit will follow the unit's programmed schedule and broadcast the schedule so that other devices programmed to follow this schedule number can receive the schedule. If

the unit is not programmed as a Global Schedule Broadcaster (**BROADCAST SCHEDL? = NO**), the unit will receive broadcasted schedules from a unit programmed to broadcast this schedule number.

HUMIDITY DEMAND

When the unit is configured for either a Humidistat input (**HUMSTAT CHANNEL**) or Space Humidity Sensor (**SPRH SENS CHANNEL**), the level 5 demand in Table 9 will include a determination of dehumidification demand.

HUMIDISTAT

When receiving an active input from the Humidistat (**HUMID-ISTAT**), dehumidification will be demanded.

SPACE RELATIVE HUMIDITY

On units with a relative humidity sensor, when the received value of space relative humidity (**SPRH LEVEL**) has exceeded the humidity set point (**SPRH SET POINT**), dehumidification will be demanded. This demand will remain until the space relative humidity has fallen below the humidity set point by more than the humidity set point deadband (**SPRH DEADBAND**). This would come from the space humidity sensor or building network.

Indoor Fan Operation

These units use the Staged Air Volume (SAV™) method of controlling the supply fan for a typical constant volume rooftop unit. This control method employs a variable frequency drive (VFD) to operate the supply fan at different speeds in order to achieve energy savings through reduced fan power. This method is specifically not concerned with controlling static pressure in the supply duct, but rather with setting different fan speeds for different operating conditions, such as ventilation mode or part-load mechanical cooling.

The SAV function is NOT a Variable Air Volume (VAV) function. The fan adapts its speed to one of eight options based on mode and current state to satisfy a demand. The eight speeds consist of: off (0%) and seven configurable values. The seven configurable fan speeds are: Maximum Speed (**MAXIMUM IDF SPEED**), Ventilation (**VENT IDF SPEED**), Heating (**HEATING IDF SPD**), Free Cool (**FREE COOL IDF SPD**), Mechanical Low Cooling (**LOW COOL IDF SPD**), Mechanical Medium Cooling (**MED COOL IDF SPD**), and Mechanical High Cooling (**HIGH COOL IDF SPD**). The VFD is powered direct from the distribution block or circuit breaker (CB) and is always on with power applied unless the CB is tripped. When the thermostat or space sensor control conditions require the fan on, the VFD will then ramp to desired speed. Fan speed is always calculated by evaluating the current applicable conditions. Each fan speed condition is evaluated independently, and the highest fan speed is used. For example, if a cooling call occurs during Ventilation mode, the unit mode will transition to cooling but the fan speed is set to the higher of the two (**VENT IDF SPEED** or **LOW COOL IDF SPD**). Refer to the speed configurations below for when the fan will run at the various speeds.

DIRECT DRIVE UNITS

Alternately, 48/50LC*04-06 units can have either a direct drive Electronic Commutated Motor (ECM) fan system or a belt drive motor powered by a Variable Frequency Drive (VFD). An **IDF-TYPE=1** indicates a unit with VFD, while an **IDFTYPE=2** indicates a direct drive system. Refer to the unit product data for fan performance tables and physical data. On direct drive units, the ECM has 5 speed taps to allow a range of fan performance. The control has 3 output wires to connect to 3 different taps. At the factory, the low and high speed wires are connected to the first and second speed taps, respectively. The ventilation speed tap is disconnected. The speed taps increase in speed the higher the tap number, so tap 1 is the lowest speed and tap 5 is the highest speed. If the low and high speed wires are moved to higher taps, the ventilation speed wire can be wired into the motor. To

activate the use of the ventilation speed wire, the Number of Speeds (**SETTINGS** → **UNIT CONFIGURATIONS** → **INDOOR FAN** → **NUMFSPDS**) configuration must be set to 3.

The Commanded Fan Speed (**OUTPUTS** → **INDOOR FAN** → **FANSPEED**) represents the control's commanded speed for the fan at any given time. This commanded speed is determined by the unit's current HVAC mode and the unit control type. For gas heating units, the IGC fan request output (**Inputs** → **GEN.I** → **IGC.F**) is monitored by the control. This can result in additional modification of fan delays or other operation due to safety functions of the IGC control. See "Heating Operation" on page 25 for more details. If configured for IAQ fan operation, the fan may be turned on to satisfy air quality demands. See "Indoor Air Quality (IAQ)" on page 30 if using IAQ (indoor air quality) accessory sensors. The fan can run under thermostat or space sensor control and will remain on if compressors or heat relays are ever stuck on. If Shut Down on IDF Failure is enabled (**SHUT-DOWN IDF FAIL = Yes**), the fan and unit will be shutdown without delay on fan alarm conditions. Fan off delays are honored when exiting specific HVAC modes. The Fan-off Delay delays are as follows: Cooling (**COOL FANOFF DELAY**), and Heating (**HEAT FANOFF DELAY**).

Indoor (Supply) Fan Maximum Speed (MAXIMUM IDF SPEED)

Max speed is the highest fan speed allowed. This is typically 100% when pulleys are set to deliver design CFM to the space per job requirement. Most safety conditions for the unit will override the fan speed to this to help protect the unit.

Ventilation Indoor Fan Speed (VENT IDF SPEED)

This configuration defines the fan speed used in Ventilation (fan-only) mode. Ventilation mode is when the supply fan is running, but there is no demand for heating or cooling. In thermostat mode, this is with just a G call. In space sensor control, this is when the unit is Occupied mode and the indoor fan is configured to always run while occupied (**OCCUPIED FAN?**). If the indoor fan is configured for intermittent fan (**OCCUPIED FAN? = No**), the Mode will be off instead of Ventilation and the fan will not run unless a heating or cooling mode is needed. During the unoccupied period, the fan will always operate intermittently. The economizer damper will adjust its position based on how far away this speed is from max speed for ventilation.

IMPORTANT: It is important that the ventilation rate is checked after setting this speed to verify that the unit can properly ventilate the space per requirements. Adjusting this configuration or the economizer minimum setting curve should be performed to meet job requirements.

Heating Indoor Fan Speed (HEATING IDF SPD)

This configuration defines the fan speed used when in heating mode and running heat. On units equipped with gas heat (**UNIT TYPE OF HEAT**), this heat speed will be delayed on based on the IGC's fan on call (**IGC FAN REQUEST**). Once the IGC requests the fan, the fan will run what this heating speed configuration is set for until heating is ended. On units configured for electric heat (**UNIT TYPE OF HEAT**) and configured for Preheat without the fan (**PREHEAT W/O IDF**), this heat speed will be delayed on based on the Preheat fan delay time (**PREHEAT FAN DELAY**). Once this preheat time has expired or not configured for preheat, the fan will run at this heat speed while heat is on.

Free Cooling Indoor Fan Speed (FREE COOL IDF SPD)

This configuration defines the initial fan speed used when in Free Cooling. Refer to "Economizer Operation" on page 27 for details on free cooling. The fan will stay at this configured speed whenever only the damper is being used for free cooling. If the damper is at 100% for 5 minutes, the fan will ramp to the high cooling speed. It is locked there until the actual damper position falls below 75%, at which time it will ramp back down to this configured speed.

Low Cooling Indoor Fan Speed (LOWCOOL IDF SPD)

This configuration defines the fan speed used when only one stage mechanical cooling is being performed.

Medium Cooling Indoor Fan Speed (MED COOL IDF SPD)

This configuration defines the fan speed used when only second stage mechanical cooling is being performed.

High Cooling Indoor Fan Speed (HIGH COOL IDF SPD)

This configuration defines the fan speed used when third (full load) stage mechanical cooling is being performed. When performing integrated cooling with the economizer, this speed will be used. When only free cooling with a high cool demand, this speed will be used.

Cooling Operation

The 48/50LC unit's cooling operation consists of: demand and mode determination, staging request to satisfy the demand, and handling a request with the unit's resources. These resources can include compressors, Humidi-MiZer® system, an economizer, and fan speed based on options. This section covers mechanical cooling. For economizer free cooling, refer to "Economizer Operation" on page 27.

For Humidi-MiZer system operation, refer to "Optional Humidi-MiZer Dehumidification System" on page 21.

COOLING MODE CONTROL

The cooling HVAC mode (**OPERATING MODE**) has 9 different operating sub modes (**SUBMODE**): ECON FREE COOLING, UNOCC. FREE COOL, MECH. COOLING, ECON/MECH COOLING, DEHUMIDIFICATION, DEHUM/MECH COOLING, DEHUM PREVENTED, COOLING PREVENTED, and SHUTTING COOL OFF. These are all part of a general cooling mode and resemble the specific type of cooling that is being performed at any given time. All types of cooling are still performed under the general cooling function, and the expanded text is for user reference only.

For the unit to enter cooling mode, three things must be true: the indoor fan must be ok to use, the mode changeover time guard must be expired, and there must be a cooling or dehumidification demand (Y1, Y2, Y3, space cool demand, or humidity demand). The unit will remain in cooling for at least one minute or until any of the above conditions turn false. The cooling mode does not officially end until the compressor is off and the fan off delay has expired.

COOLING STAGING CONTROL

Once the unit is in a cooling mode, determine what the demand is and how to satisfy it. If an economizer is installed and can be used for cooling (**OK TO USE FREE COOLING? = Yes**), the unit will use it first (see "Economizer Operation" on page 27 for its operation). If the economizer cannot be used or additional cooling is needed, a mechanical cooling check is performed. OK to use Compressors? (**OK TO USE COMPS?**) will be set to yes when the outdoor temperature (**OUTDOOR AIR TEMP**) is above the Circuit A Lockout temperature (**CIR.A LOCKOUT OAT**) and the Circuit A is not locked out for diagnostic reasons (**CIRCUIT A LOCKOUT**). Based on the unit control configuration, requested cooling stages (**REQ. COOL STAGES**) will be determined then passed to compressor control to actually add the cooling stages.

There are two ways of requesting stages when thermostat control is enabled: traditional thermostat control or adaptive control. Traditional thermostat control is used if set for non-adaptive thermostat (**ADAPTIVE TSTAT = NO**) and the unit cannot use the economizer for free cooling. If set for adaptive thermostat (**ADAPTIVE TSTAT = YES**) or any time the economizer is available for free cooling, the unit will use adaptive control for staging.

When configured for space sensor or RAT control (**UNIT CONTROL TYPE**), the unit will use adaptive control for staging. With either staging method there are two supply air temperature limits that apply, one restricts more cooling stages and the other

will remove cooling stages. If at any time the Supply-Air Temperature (**SUPPLY AIR TEMP**) falls below the Minimum Supply Air Temperature Upper Level (**UPPER MIN SAT**), the requested stages will not be allowed to increase. If at any time the SAT falls below the Minimum Supply Air Temperature Lower Level (**LOWER MIN SAT**), the requested stages will be reduced by one. If these SAT limits are configured so that they are too close together, the last stage might cycle rapidly, slowed only by its minimum on and off-time requirements.

Adaptive Control

Stage timers and Supply air trend apply when determining the request for stages. The first request (**REQ. COOL STAGES =1**) comes immediately when starting the staging process. The Cool Stage Increase Time (**COOL STAGEUP TIME**) has to expire and the Supply-Air Trend (**SUPPLY AIR TREND**) has to be above the cooling supply air trend level (**COOL SATTREND LEV**) before another stage can be added. Requested stages will only be allowed to increase as the actual system demand allows (**DEMAND**). A “LOW COOL” demand will only allow one requested stage, “MED COOL” two stages, and “HIGH COOL” 3 stages. The requested stages will be reduced if the cooling demand is lowered or dropped completely, or if the supply air falls below the lower level (**LOWER MIN SAT**).

Traditional Thermostat Control

Stage timers and Supply air trend do not apply when determining the request for stages. Request staging will follow the thermostat inputs directly. “LOW COOL” will request one stage. “MED COOL” will request two stages. “HIGH COOL” will request 3 stages.

COMPRESSOR CONTROL

The compressor control works hand in hand with the staging control. As the staging control request stages, the compressor control determines what is available or running and tries to provide stages for what is requested. The availability of the compressors depends on time guards, circuit diagnostics, and outdoor temperature. The low cooling compressor (**LOW COOL COMP**) informs the control which compressor is desired for a low cooling demand.

IMPORTANT: When LOW COOL COMP is set to 2, the unit will operate as a 2 stage unit where the larger compressor is stage one and both compressors are stage 2.

There are time guards to protect the compressor: Compressor Min On Time (**COMP MIN ON TIME**) and Compressor Min Off Time (**COMP MIN OFF TIME**) apply before the compressors can be turned back on or turned off. Timeguard A1 (**COMP A1 TIMEGUARD**) and Timeguard A2 (**COMP A2 TIMEGUARD**) display the time the compressors have before they can transition state.

Circuit diagnostic tests are performed during operation which may or may not allow the compressors to be used. The availability of the compressors is shown as Compressor A1 Available (**COMP A1 AVAILABLE**) and Compressor A2 Available (**COMP A2 AVAILABLE**). The lockout status of the compressors is shown as Compressor A1 Lockout (**COMP A1 LOCKOUT**) and Compressor A2 Lockout (**COMP A2 LOCKOUT**). The actual stages running at any given time is displayed as Actual Cooling Stages (**ACTIVE COOL STAGE**): 0 (Off), 1 (Compressor A1 On only), 2 (Compressor A2 On only), and 3 (both compressors are on). Individual compressor output state is shown as (**COMPRESSOR A1**) and (**COMPRESSOR A2**).

Any time the outdoor ambient falls below the low cooling minimum outdoor temperature (**LOW COOL MIN OAT**), the low cooling lockout will be active (**LOW COOL LOCKOUT**), preventing compressor A1 from running by itself. Any time the outdoor ambient falls below the medium cooling minimum outdoor temperature (**MED COOL MIN OAT**), the medium cooling

lockout will be active (**MED COOL LOCKOUT**) preventing compressor A1 and compressor A2 from running by themselves.

OUTDOOR FAN CONTROL

Outdoor fans can be controlled by one of two methods: normal operation of discrete speed based on the cooling being performed, or low ambient operation that varies the outdoor airflow to control saturated discharge temperature within an acceptable range. This is implemented using multi-speed motors. The system outdoor fan speed (**COMMANDED ODF SPD**) represents the commanded speed of all outdoor fan motors as a complete system. The number of outdoor fans in the system is determined by the number of outdoor fan outputs (**ODF SIGNAL QTY**).

IMPORTANT: The number of outdoor fans will not always match the number of outdoor fan outputs (**ODF SIGNAL QTY**). Fig. 12 shows how the outdoor fans are mapped with the outdoor fan outputs.

NOTE: Factory default configurations account for these model differences and should not be changed. The default configurations have been qualified over a large range of conditions and are provided in case a field replacement of a control board occurs and the settings need to be checked or manually configured. Outdoor fan operation is further described below to assist in troubleshooting.

Typical Operation

When OAT is above low ambient temperature (**LOW AMBIENT TEMP**), the ODFs will run at 4 discrete speeds: Off, Low Cool Speed (**ODF LOW COOL SPD**), Medium Cool Speed (**ODF MED COOL SPD**), and High Cool Speed (**ODF HIGH COOL SPD**), corresponding to the 4 discrete cooling stage of the compressors (**ACTIVE COOL STAGE**): 0 (Off), 1 (Compressor A1 On only), 2 (Compressor A2 On only), and 3 (both compressors are on).

Low Ambient Operation

Low ambient operation will be used when either of the 2 conditions is met: 1) OAT is less than low ambient temperature (**LOW AMBIENT TEMP**) – 5°F or 2) OAT is less than low ambient temperature (**LOW AMBIENT TEMP**) – 2.5°F and the Saturated Discharge Temperature (**CIR.A DIS. TEMP**) is less than 92°F. The low ambient ODF control will manipulate ODF speed to keep the discharge temp above 95°F. As OAT continues to drop, ODF speed will continue to decrease. At a certain point, the low ambient control may decide to turn off ODFs and only control the speed of the rest of the outdoor fans. If the discharge temp keeps on decreasing, it may reach a point that all ODF fans will be turned off. The ODFs will be turned on starting from the highest number first, meaning the ODF1 will be the last one to shut off. The ODFs are protected with a 45 second run time and a 60 second off time. See Fig. 12 for the ODF arrangement. The lowest speed allowed to run any ODF is determined by the outdoor fan Minimum Speed Configuration (**ODF MINIMUM SPEED**).

NOTE: During ODF cycling all fans that are commanded on will be at the same speed and the off ones will be at zero speed. The motors will not be allowed to run different speeds at the same time.

When OAT rises above low ambient temperature (**LOW AMBIENT TEMP**), ODF control will transition from low ambient to normal operation. A period (5 min) is allowed for the ODF speed to ramp from current position to one of the 4 discrete speed settings.

IMPORTANT: The low ambient temperature (**LOW AMBIENT TEMP**) is default to 66 degrees and should not be changed unless directed by authorized Carrier personnel.

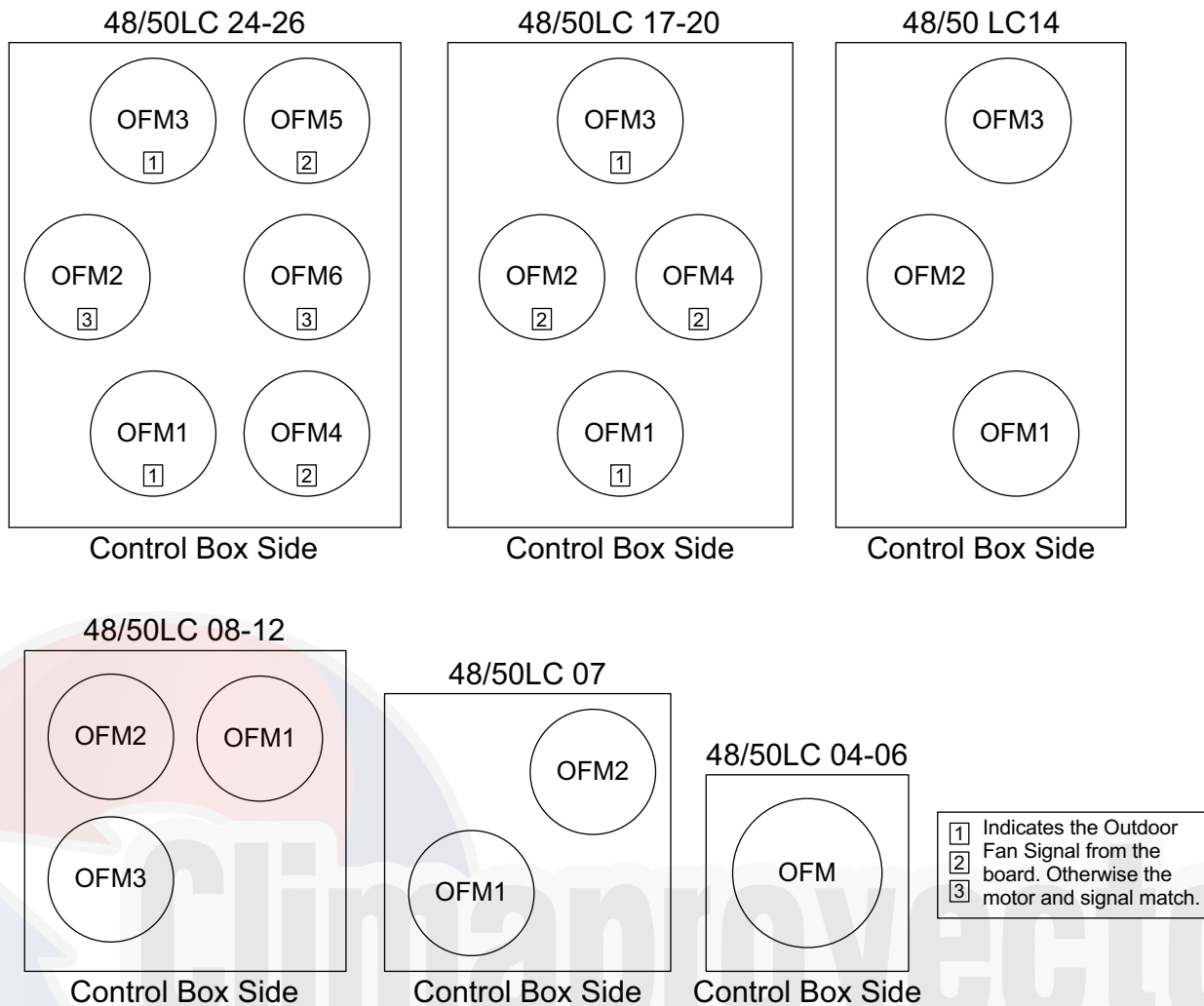

Fig. 12 — Outdoor Fan Motor Arrangement

Optional Humidi-MiZer Dehumidification System

Units with the factory-installed Humidi-MiZer system option are capable of providing multiple modes of improved dehumidification as a variation of the normal cooling cycle. The Humidi-MiZer system option includes additional valves in the liquid line and discharge line of each refrigerant circuit, a re-heat coil downstream of the evaporator, and variable-speed control of all the outdoor fans. The Humidi-MiZer system equipped configuration is factory set to Yes for Humidi-MiZer system equipped units (**HUMIDIMIZER OK = YES**). This enables Humidi-MiZer system operating modes and service test.

Humidi-MiZer system operation requires the installation and configuration of a relative humidity switch input or a space relative humidity sensor. The HUMIDISTAT and SPRH leads are provided with quick connects. The Space Humidity Switch configuration, **SETTINGS → UNIT CONFIGURATIONS → SWITCH INPUTS CONFIGS → HUMSTAT CHANNEL** identifies the normally open or normally closed status of this input at high humidity. The Space RH Sensor configuration, **SETTINGS → UNIT CONFIGURATIONS → ANALOG INPUTS CONFIGS → SPRH SENS CHANNEL**, identifies to the channel number the sensor is wired into.

DEHUMIDIFICATION DEMAND

When using a humidistat or switch input, the demand for dehumidification is seen as Space Humidity Switch (**INPUTS →**

SWITCH INPUTS → HUMIDISTAT) being Low or High. A low value means humidity level is good and a high value means that dehumidification is needed.

When using an SPRH sensor, the demand is based on the Space Humidity Sensor (**INPUTS → ANALOG INPUTS → SPRH**) value compared to the Space RH Setpoint (**SETTINGS → SPACE SETPOINTS → SPRH SETPOINT**). If the Space Humidity Sensor (SPRH) value is above the Space RH Setpoint (SPRH Setpoint), then dehumidification is needed. If the Space Humidity Sensor (SPRH) value is below the Space RH Setpoint (SPRH Setpoint) minus the Space RH Deadband (**SETTINGS → UNIT CONFIGURATIONS → COOLING → SPRH DEADBAND**), then dehumidification is no longer needed.

NOTE: When there is a dehumidification demand, the economizer damper position is limited to its minimum damper position.

HUMIDI-MIZER SYSTEM MODES

With Humidi-MiZer system units, there are two additional HVAC modes available for the user: Dehumidification and Dehum/Mech Cooling. Selection of the Dehum/Mech Cooling mode is determined by the dehumidification demand and the cooling demand. Tables 13 and 14 show the corresponding circuit mode and output status for the different demand combinations.

Table 13 — Humidi-MiZer System Control Modes (Sizes 04-06)

DEMAND AND MODE			OUTPUTS	48/50LC 04-06 VALVES		
Space Humidity	Circuit Cooling Demand	Circuit Mode	Circuit Compressor	RDL Valve	RLV Valve	CLV Valve
—	—	No power	Off	Off (closed)	Off (open)	Off (open)
Low	No	Off	Off	Off (closed)	On (closed)	Off (open)
	Yes	Cool	On	Off (closed)	On (closed)	Off (open)
High	Yes	Dehum/Mech Cooling	On	Off (closed)	Off (open)	On (closed)
	No	Dehum	On	On (open)	Off (open)	On (closed)

Table 14 — Humidi-MiZer System Control Modes (Sizes 07-26)

DEMAND AND MODE			OUTPUTS	48/50LC 07-26 VALVES	
Space Humidity	Circuit Cooling Demand	Circuit Mode	Circuit Compressor	LDV Valve 3-way	RDV Valve 2-way
—	—	No power	Off	Off	Off (closed)
Low	No	Off	Off	Off	Off (closed)
	Yes	Cool	On	Off	Off (closed)
High	Yes	Dehum/Mech Cooling	On	On	Off (closed)
	No	Dehum	On	On	On (open)

NORMAL COOLING

For 48/50LC04-06 units, refrigerant flows from the outdoor condenser and is diverted at the energized Reheat Liquid Valve (RLV) and flows through the de-energized Cooling Liquid Valve (CLV) to the expansion device bypassing the reheat condenser coil. The RDV is closed (see Fig. 13)

For 48/50LC07-26 units, refrigerant flows from the outdoor condenser through the de-energized 3-Way Liquid Diverter Valve (LDV) to the expansion device bypassing the reheat condenser coil. The Reheat Discharge Valve (RDV) is closed. (See Fig. 14.)

DEHUM/MECH COOLING (SUBCOOLING MODE)

This mode increases latent heat removal and decreases sensible cooling compared to normal cooling.

For 48/50LC*04-06 units, refrigerant flows from the outdoor condenser through the de-energized Reheat Liquid Valve (RLV) and through the reheat condenser coil to the expansion device. The Reheat Discharge Valve (RDV) and Cooling Liquid (CLV) are closed. (See Fig. 15.)

For 48/50LC*07-26 units, refrigerant flows from the outdoor condenser, through the energized 3-Way Liquid Diverter Valve (LDV) and through the reheat condenser coil to the expansion device. The Reheat Discharge Valve (RDV) is closed. (See Fig. 16.)

DEHUMIDIFICATION (HOT GAS REHEAT MODE)

This mode provides maximum latent cooling with little to no sensible capacity. This mode can operate to provide dehumidification when there is no cooling demand.

For 48/50LC*04-06 units, The refrigerants flows from the outdoor condenser, through the de-energized RLV and through the reheat condenser coil to the expansion device. The Cooling Liquid Valve (CLV) is closed. (See Fig. 17.)

For 48/50LC*07-26 units, the refrigerant flows from the outdoor condenser, through the energized 3-Way Liquid Diverter Valve (LDV) and through the reheat condenser coil to the expansion device. (See Fig. 18.)

For 48/50LC*04-26 units, the Reheat Discharge Valve (RDV) is open, which provides some compressor discharge gas to the reheat condenser to further increase the reheat of the evaporator air stream. (See Fig. 17 and 18.)

REHEAT CONTROL

When there is only a cooling demand, the unit will operate in normal cooling mode. When there is only dehumidification demand, the unit will operate in Dehumidification mode (Hot Gas Reheat). When there is both cooling demand and dehumidification demand, the unit will operate in Dehum/Mech Cooling mode (Subcooling). During Dehumidification and Dehum/Mech cooling mode, the unit will run all cooling stages. When the Outside Air Temperature is above 80°F, the Outdoor Fans will run at maximum fan speed. When the Outside Air Temperature is below 80°F, the Outdoor Fans will modulate to maintain Saturated Discharge Temperature setpoint **LA DEHUM LEV 1**, **LA DEHUM LEV 2** and **LA DEHUM LEV**, (**SETTINGS** → **UNIT CONFIGURATIONS** → **COOLING** → **LOW AMBIENT**). The unit can be restricted from reheat operation by the outside temperature **HUMZ LOCKOUT OAT** (**SETTINGS** → **UNIT CONFIGURATIONS** → **COOLING** → **HUMZLOCKOUT OAT**) sets the lowest outside temperature the unit is allowed to run reheat control (Default = 40°F).

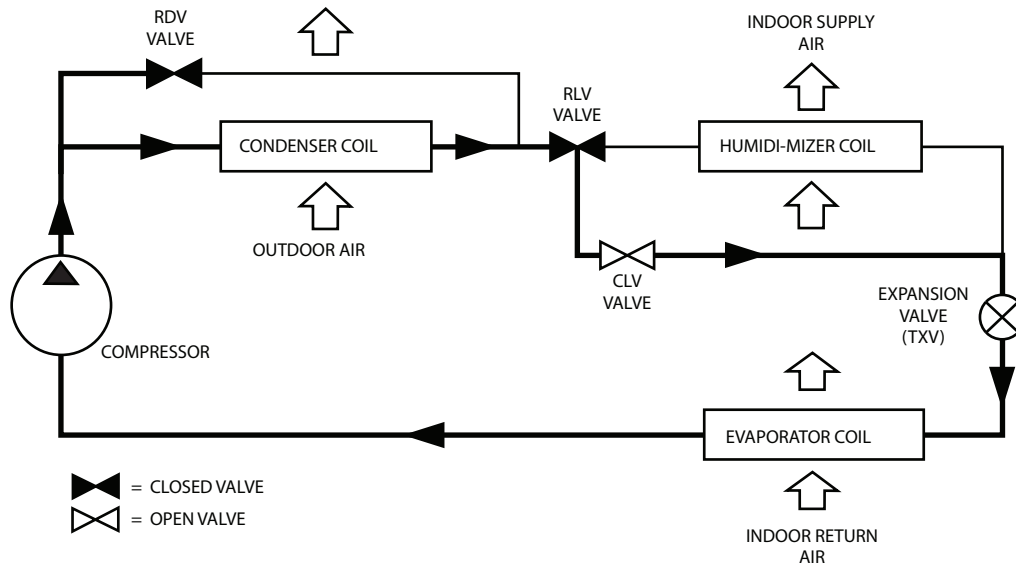

Fig. 13 — Normal Cooling Mode – Humidi-MiZer System for 48/50LC*04-06

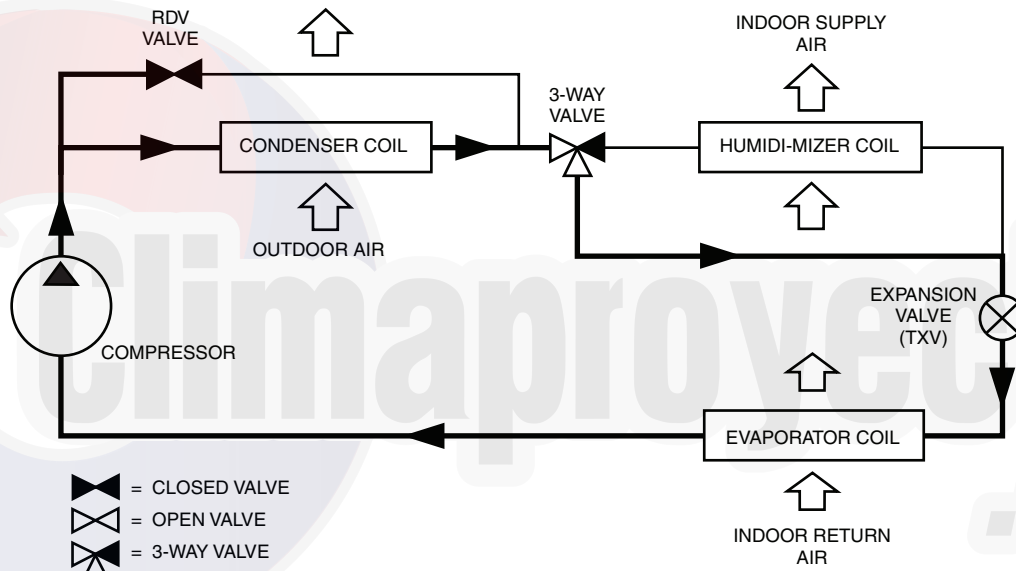

Fig. 14 — Normal Cooling Mode – Humidi-MiZer System for 48/50LC*07-26

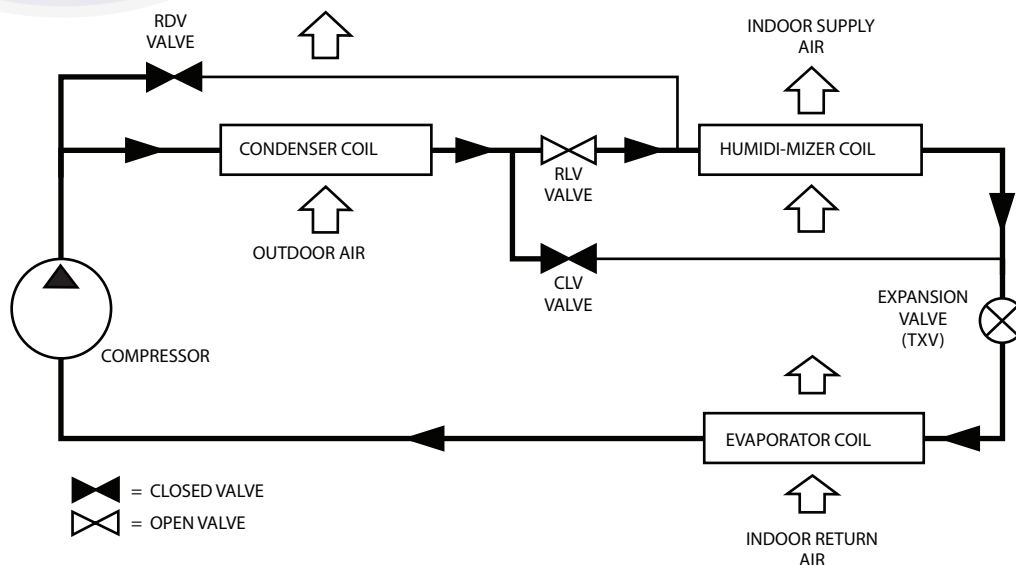

Fig. 15 — Subcooling Mode – Humidi-MiZer System for 48/50LC*04-06

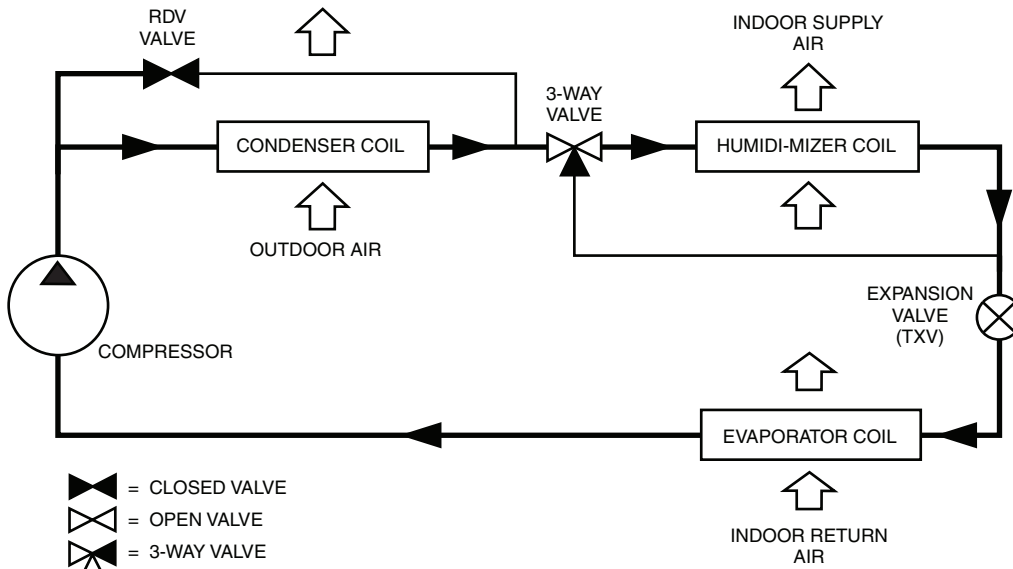

Fig. 16 — Subcooling Mode – Humidi-MiZer System for 48/50LC*07-26

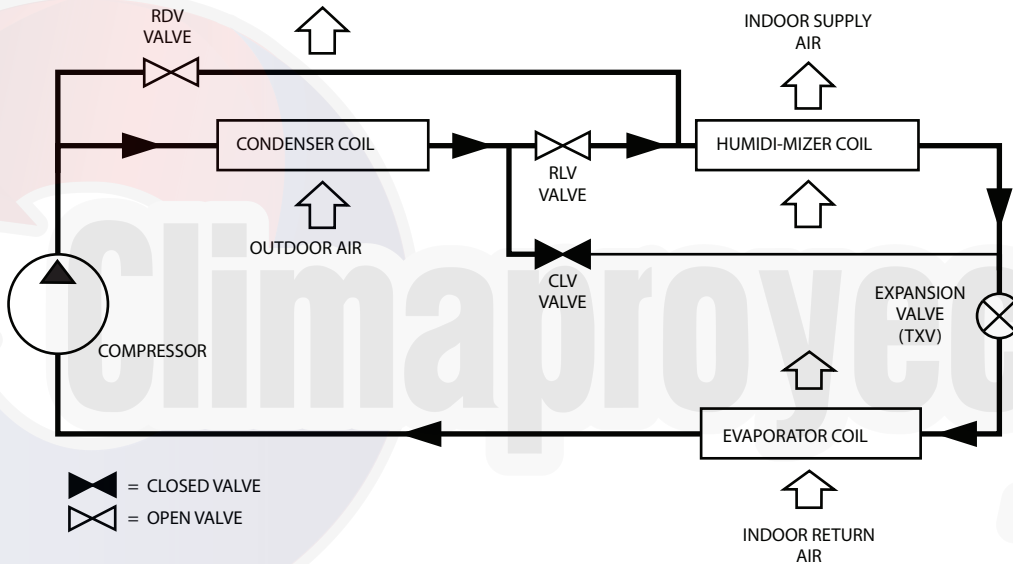

Fig. 17 — Hot Gas Reheat Mode – Humidi-MiZer System for 48/50LC*04-06

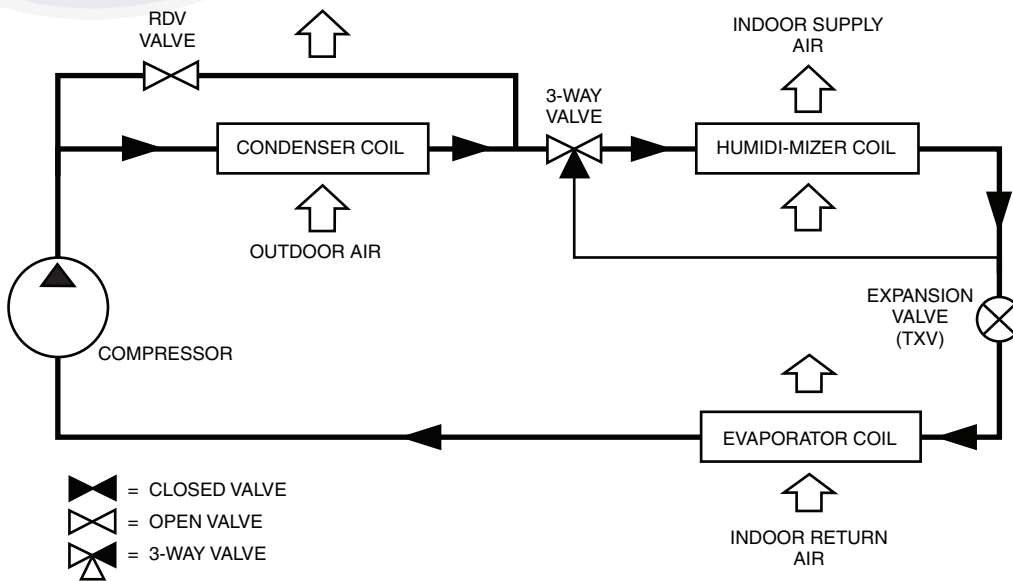

Fig. 18 — Hot Gas Reheat Mode – Humidi-MiZer System for 48/50LC*07-26

REHEAT MODE DIAGNOSTIC HELP

The status of reheat mode sensor inputs may be viewed within the display **INPUTS** menu. The status of reheat mode outputs may be viewed within the display **OUTPUTS** or **RUN STATUS** → **MODE** menu. Additional diagnostic help, including status of circuit reheat temperature limit lockouts may be viewed within the Humidi-MiZer sub-menu of the cooling mode diagnostic table at **RUN STATUS** → **COOL** → **DEHUM**. The Service Test mode may be used to force the system to operate Dehumidification mode (Hot Gas Reheat) and Dehum/Mech Cooling mode (Subcooling), or to independently operate the reheat valve control outputs.

The following forced operating states are available service test operations for a Humidi-MiZer system equipped unit:

SERVICE TEST → **COOL TEST** → **HUMIDIMIZER TEST LEVEL**

A value of “0” sets reheat control test to “Off.”

SERVICE TEST → **COOL TEST** → **HUMIDIMIZER TEST LEVEL**

A value of “1” sets Humidi-MiZer control test to “Dehum/Mech Cooling mode (Subcooling).”

SERVICE TEST → **COOL TEST** → **HUMIDIMIZER TEST LEVEL**

A value of “2” sets Humidi-MiZer test to “Dehumidification mode (Hot Gas Reheat).”

SERVICE TEST → **INDEPENDENTS** → **LIQ DIVERT A TEST**

A value of “On” will turn on the 3-Way Liquid Diverter Valve (LDV).

SERVICE TEST → **INDEPENDENTS** → **REHEAT A TEST**

A value of “On” will turn on the Reheat Discharge Valve (RDV).

Indoor Fan Based Dehumidification

Belt drive units that are not factory configured for Humidi-MiZer operation can be set for improved dehumidification operation through fan based humidification (FBD), **SETTINGS** → **UNIT CONFIGURATIONS** → **COOLING** → **FBD TYPE**. Units are factory defaulted to **FBD TYPE = 0**, which means that any dehum demand is ignored. There are two fan based dehumidification options: Max Comfort (**FBD TYPE = 1**) and Max Dehumidification (**FBD TYPE = 2**). Fan based dehumidification requires the installation and configuration of either a space relative humidity sensor or a relative humidity switch input. The Space Humidity Switch configuration, **SETTINGS** → **UNIT CONFIGURATIONS** → **SWITCH INPUTS CONFIGS** → **HUMSTAT CHANNEL**, identifies the normally open or normally closed status of this input at HIGH humidity. The RH Sensor configuration, **SETTINGS** → **UNIT CONFIGURATIONS** → **ANALOG INPUTS CONFIGS** → **SPRH SENSOR CHANNEL**, identifies the point on the MBB (Main Base Board) or the IOB (Input Output board) the sensor was wired into.

MAX DEHUM

When the FBD Type is set to (2) Max Dehum, the control will try to satisfy the dehumidification demand. When the unit receives a dehum demand, a PID control algorithm will modulate the indoor fan while the compressor is running to maintain minimum suction temperature (FBDH_SST). With a Y1 and dehum demand, the unit will run the compressor unloaded (48/50LC04-06) or will run the A1 compressor only (48/50LC07-26). With a Y2 and dehum demand, the unit will run with the compressor at full load (48/50LC04-06) or will run with the A2 compressor only (48/50LC07-26). With a Y3 and dehum demand (48/50LC07-26 only), the unit will run both compressors.

MAX COMFORT

When the FBD Type is set to (1) Max Comfort, the control will try to satisfy the dehumidification demand and minimize cold air dump. When the unit receives a dehum demand, a PID control algorithm will modulate the indoor fan while the compressor is running to maintain the minimum FBD supply air comfort set point (FBDH_SAT) while also maintaining the minimum suction temperature (FBDH_SST). With a Y1 and dehum demand, the unit will run the compressor unloaded (48/50LC04-06) or will run the A1 compressor only (48/50LC07-26). With a Y2 and dehum demand, the unit will run with the compressor at full load (48/50LC04-06) or will run with the A2 compressor only (48/50LC07-26). With a Y3 and dehum demand (48/50LC07-26 only), the unit will run both compressors.

Heating Operation

The 48/50LC unit’s heating operation consists of: demand and mode determination, staging request to satisfy the demand, and handling a request with the unit’s resources. These resources can be gas heat or electric heat. This section covers both gas heat units and electric heat units. The Type of Heat Installed (**UNIT TYPE OF HEAT**) configuration will be factory set to 1 for gas units and 0 for electric heat units. The unit enters a heating mode based on a demand, decides how to satisfy the demand, executes its plan, and then leaves the heating mode.

HEATING MODE CONTROL

The heating HVAC mode (**OPERATING MODE**) has 3 different operating sub modes (**SUBMODE**): HEATING, HEATING PREVENTED, and SHUTTING HEAT OFF. These are all part of a general heating mode and resemble the action heat mode is taking at any given time. All types of heating are still performed under the general heating function, and the expanded text is for user reference only.

For the unit to be allowed to enter the heat mode, three things must be true: the indoor fan must be okay to use, the mode changeover time guard must be expired, and there must be a heating demand. The unit will remain in heating for at least one minute and until the demand is dropped or if any of the above conditions are false. The heating mode does not officially end until all heat stages are off, the fan off delay has expired, and the IGC fan request is dropped.

SUPPLY-AIR TEMPERATURE SENSOR (SAT) HEAT MODE

The SAT Heat Mode Sensing (**SAT DURING HEAT?**) informs the unit that the supply air sensor has been relocated downstream of the heat section. This configuration affects the Supply Air Temperature (**SUPPLY AIR TEMP**) value displayed as listed below. **SAT DURING HEAT?** is enabled at the factory.

When **SAT DURING HEAT?** is disabled, the Supply Air Temperature (**SUPPLY AIR TEMP**) value on the SystemVu™ display and the network will hold a zero when heat outputs come ON and for 5 minutes after. The default SAT sensor location is on the fan deck near the corner post.

When **SAT DURING HEAT?** is enabled, the Supply Air Temperature (**SUPPLY AIR TEMP**) sensor reading is displayed at the SystemVu controller and network during heating mode. This setting should only be used if the original SAT sensor wires are removed from the Main Base Board (MBB) and replaced by an accessory SAT sensor located in the supply duct downstream of the heat section.

HEATING STAGING CONTROL

Once the unit is in a heating mode, it determines what the demand is and how to satisfy it. Requested Heating Stages (**REQ. HEAT STAGES**) will be determined, then passed to heat control to actually add the heating stages. To request stages, the number of heat stages (**HEATING STAGE QTY**) must be greater than zero. As a gas unit this will be set in the factory; however,

50LC units may have heat installed as accessories. If the Outdoor Air Temperature (**OUTDOOR AIR TEMP**) is greater than the Heating Lockout Temp (**HEAT LOCKOUT OAT**), all the heat stages will be locked out (**HEAT LOCKOUT**).

There are two ways of requesting stages when thermostat control is enabled, traditional thermostat control or adaptive control. Traditional thermostat control is used if set for non-adaptive thermostat (**ADAPTIVE TSTAT = NO**). If set for adaptive thermostat (**ADAPTIVE TSTAT = YES**), the unit will use adaptive control for staging. When configured for space sensor or RAT control (**UNIT CONTROL TYPE**), the unit will use adaptive control for staging. With either staging method there are then two supply air temperature limits, the Maximum SAT Lower Level (**LOWER MAX SAT**) the Maximum SAT Upper Level (**UPPER MAX SAT**). Any time the supply air temperature rises above lower level, the heat staging will be limited to what is currently on and no additional stages will be added until the supply air temperature falls back below the lower level. If the supply air temperature rises above the upper level, then heating will be reduced by removing one stage. That stage will not be added again until the Supply Air Temperature falls below the lower level. If the supply air temperature stays above the upper level, then another stage will be removed. If the upper and lower levels are configured so that they are close together, the last stage of heat might cycle rapidly, slowed only by its minimum on and off-time requirements.

Adaptive Control

Stage timers and supply air trend apply when determining the request for stages. The first request (**REQ. HEAT STAGES = I**) comes immediately when starting the staging process. The Heat Stage Increase Time (**HEAT STAGEUP TIME**) has to expire and the Supply-Air Trend (**SUPPLY AIR TREND**) has to be above the Heating supply air trend level (**HEAT SAT-TREND LEV**) before another stage can be added. Requested stages will only be allowed to increase as the actual system demand allows (**DEMAND**). A “LOW HEAT” will only allow one requested stage and “HIGH HEAT” 2 stages. The requested stages will be reduced if the heating demand is lowered or dropped completely, or if the supply air falls below the lower level (**LOWER MIN SAT**).

Traditional Thermostat Control

Stage timers and supply air trend do not apply when determining the request for stages. Request staging will follow the thermostat inputs directly. “LOW HEAT” will request one stage. “HIGH HEAT” will request 2 stages.

HEAT RELAY CONTROL

The heat relay control is responsible for energizing or de-energizing the heat stage relays and works hand in hand with the staging control. As the staging control requests stages, the heat relay control determines what actual heat relays are available or energized and tries to provide stages for what is requested. The availability of heat relays depends on the heat installed, how many stages, and time guards. The Number of Heat Stages (**HEATING STAGE QTY**) configuration tells the control how many heat relays can be used. Heat Stage 1 Timeguard (**HEAT 1 TIMEGUARD**) and Heat Stage 2 Timeguard (**HEAT 2 TIMEGUARD**) display the time a respective heat relay has before it can change state. The available stages at any given time are displayed as heat 1 available and heat 2 available (**HEAT 1 AVAILABLE** and **HEAT 2 AVAILABLE**). The actual heat relays on at any given time are displayed as Actual Heating Stages (**ACTIVE HEAT STAGE**). Heat Stage 1 Relay (**HEAT 1 RELAY**) and Heat Stage 2 Relay (**HEAT 2 RELAY**) are displayed on when the respective relay is energized. There are time guards to protect from short cycling, Heat Minimum On Time (**HEAT MIN ON**) and Heat Minimum Off Time (**HEAT MIN OFF**) apply before a heat relay can be turned back on or turned off.

Integrated Gas Controller (IGC)

The heat staging is determined as described above and the Integrated Gas Controller (IGC) initiates the gas heat module start-up. The Integrated Gas Controller (IGC) minimum on-time of 1 minute will be followed even if Heat Minimum On Time (**HEAT MIN ON**) is lower and during Service Test. If the IGC temperature limit switch opens within 10 minutes of the end of the gas heat cycle, the next fan off delay will be extended by 15 seconds. The maximum delay is 3 minutes. Once modified by the IGC, the fan off delay will not change back to the configured Fan-off Delay, Gas Heat (**HEAT FANOFF DELAY**) unless power is reset to the control. A light emitting diode (LED) is provided on the IGC to indicate status. During normal operation, the LED is continuously on. See “TROUBLE-SHOOTING” on page 32 if the LED is off or flashing. The IGC is located behind the gas section access panel door.

When the control energizes Heat Stage 1 Relay (**HEAT 1 RELAY**), power is sent to the W terminal on the IGC board. A check is made to ensure that the rollout switch and limit switch are closed. The induced-draft motor is then energized, and when speed is proven with the flue gas pressure switch on the motor, the ignition activation period begins. The burners will ignite within 5 seconds. If the burners do not light, there is a 22 second delay before another 5 second attempt. If the burners still do not light, this sequence is repeated for 15 minutes. After the 15 minutes have elapsed, if the burners still have not lit, heating is locked out. The control will reset when the request for heat is temporarily removed. When ignition occurs the IGC board will continue to monitor the condition of the rollout switch, limit switches, the flue gas pressure switch, as well as the flame sensor. If the unit is controlled through a room thermostat or space sensor set for auto-fan, 45 seconds after ignition occurs, the indoor fan motor will be energized (and the outdoor-air dampers will open to their minimum position). If for some reason the over temperature limit opens prior to the start of the indoor fan blower, on the next attempt, the 45 second delay will be shortened to 5 seconds less than the time from initiation of heat to when the limit tripped. Gas will not be interrupted to the burners and heating will continue. Once modified, the fan on delay will not change back to 45 seconds unless power is reset to the control. When the control energizes Heat Stage 2 Relay (**HEAT 2 RELAY**), power is supplied to the second stage of the main gas valve. If both stage 1 and stage 2 of the gas valve close, gas will be turned off to the main burners.

Supply Air Tempering

Supply Air Tempering control operates the gas or electric heat to maintain a minimum supply air temperature during conditions where very cold outdoor air causes the supply air temperature to fall below the configured Supply Air Tempering Setpoint. This occurs during periods where DCV is active and increasing the amount of outdoor air or in cases where the system is operating at very low airflow and the calculated economizer position has increased to maintain a constant ventilation rate.

The user can enable/disable Supply Air Tempering.

The following conditions must be true for the supply air tempering algorithm to operate:

- The SA Tempering is set to Yes (OK TO SA TEMPER = YES)
- The indoor fan is on
- The System Mode is in Vent (Ventilation or Supply Fan Only) or IAQ Override.
- The Outdoor Air Temperature < Minimum Cooling SAT 48°F.
- Heat type is gas or electric and Number Of Heat Stages > 0

If all the above are true, the SystemVu™ controller will monitor the SAT sensor value and operate the first stage of heat to

temper the supply air as required in order to maintain the configured SA Tempering Setpoint

Once the SA Tempering Setpoint has been satisfied, the SystemVu controller will begin the heat shutdown process. The time of the heat shutdown process can be varied based on the parameters: HEAT MIN ON and HEAT MIN OFF.

If the OAT goes above the Minimum Cooling SAT, the unit will not provide Supply Air Tempering for 5 minutes.

The SAT DURING HEAT variable needs to be set to ENABLED. This is to change the SystemVu settings to note the supply air thermistor is located on the fan deck.

Economizer Operation

The Economizer is used for ventilation, and cooling. If the indoor fan is not on, the economizer will not operate. If an economizer is installed, then Economizer Installed (**ECON INSTALLED = YES**) should be set to YES. The unit produces a 4 to 20mA signal which is then changed to a 2 to 10V signal with a 500 ohm resistor, which can control the economizer actuator. The economizer output signal is displayed by the Economizer Commanded Position (**ECON CMD POSITION**). The actuator's built-in 2 to 10 VDC feedback signal is read in as an analog input to know the actual position which is displayed as Economizer Actual Position (**ECON ACT POSITION**).

MINIMUM VENTILATION

The economizer will open to allow ventilation when the indoor fan is turned on and the unit is in the occupied state. The economizer damper position at any given time for ventilation is displayed as the Min Position in Effect (**EFFECTIVE MIN POS**). This minimum position can be effected by the indoor fan speed (F.SPD) and indoor air quality. To maintain a constant airflow through the economizer, as the indoor fan speed decreases or increases, the damper minimum position will increase or decrease, respectively. This relationship curve is shown in Fig. 19.

NOTE: The software point names are used in Fig. 19 as to not clutter the graph. These points are not individually set and therefore only visible from a network for troubleshooting.

These units can also be equipped with optional CO₂ sensors for additional indoor air quality control. When unit is equipped with a return duct CO₂ sensor or return duct CO₂ sensor and outside air CO₂ sensor, the Economizer minimum position vs. fan speed curve will be recalculated based on the CO₂ level of the return and/or outside air as shown in Fig. 19. When performing Demand Controlled Ventilation, the damper's Min Position in Effect (**EFFECTIVE MIN POS**) will operate in the shaded area of Fig. 19 based on the IAQ Level (**IAQ**) and the Commanded Fan Speed (**IDF SPEED OUTPUT**). See "Indoor Air Quality (IAQ)" on page 30 for more details on Demand Controlled Ventilation (DCV).

The damper position curve can be field adjusted per application if needed.

1. Activate test mode to control the fan and dampers to achieve the correct numbers.

2. Set the fan speed for the maximum amount needed for design CFM requirements. This should also be the IDF maximum Fan speed (**MAXIMUM IDF SPEED**).
3. Open the damper to the position which satisfies the highest ventilation requirement running maximum fan speed, and then set the Economizer minimum at maximum fan speed (**MIN POS @ MAX FAN**) to this damper position.
4. Set the fan speed to a realistic operating speed in the upper range, and then set the User Minimum Position Speed 1 (**MIN POS SPEED 1**) equal to that speed. This should be somewhere in the 80% range.
5. Open the damper to the position which satisfies the highest ventilation requirement running speed 1 fan speed, and then set the User Minimum Position Damper Position 1 (**MIN POS DAMP 1**) to this damper position.
6. Set the fan speed to a realistic operating speed in the mid-range, and then set the User Minimum Position Speed 2 (**MIN POS SPEED 2**) equal to that speed. This should be somewhere in the 60% range.
7. Open the damper to the position which satisfies the highest ventilation requirement running speed 2 fan speed, and then set the User Minimum Position Damper Position 2 (**MIN POS DAMP 2**) to this damper position.
8. Set the fan speed to a realistic operating speed in the low-range, and then set the User Minimum Position Speed 3 (**MIN POS SPEED 3**) equal to that speed. This should be lowest fan speed in planned operating range.
9. Open the damper to the position which satisfies the highest ventilation requirement running speed 3 fan speed, and then set the User Minimum Position Damper Position 3 (**MIN POS DAMP 3**) to this damper position.

The shape of the curves in Fig. 19 are determined by the configuration parameters: User Minimum Position Speed 1 (**MIN POS SPEED 1**), User Minimum Position Damper Position 1 (**MIN POS DAMP 1**), User Minimum Position Speed 2 (**MIN POS SPEED 2**), User Minimum Position Damper Position 2 (**MIN POS DAMP 2**), User Minimum Position Speed 3 (**MIN POS SPEED 3**), User Minimum Position Damper Position 3 (**MIN POS DAMP 3**), and Economizer minimum at maximum fan speed (**MIN POS @ MAX FAN**). These configurations are preset at the factory of default purposes. The Economizer minimum at maximum fan speed (**MIN POS @ MAX FAN**) should be changed based on the air balance of the unit for proper ventilation.

The user adjustable points discussed above are defaulted to zero from the factory which forces the control to use a set of default points. The default points should not be left for permanent operation, as it may cause inadequate ventilation. Economizer minimum at maximum fan speed (**MIN POS @ MAX FAN**) and at least one set of user points User Minimum Position Speed 1 (**MIN POS SPEED 1**) and User Minimum Position Damper Position 1 (**MIN POS DAMP 1**) should be used to create a linear curve to cover the broad scope of fan operation.

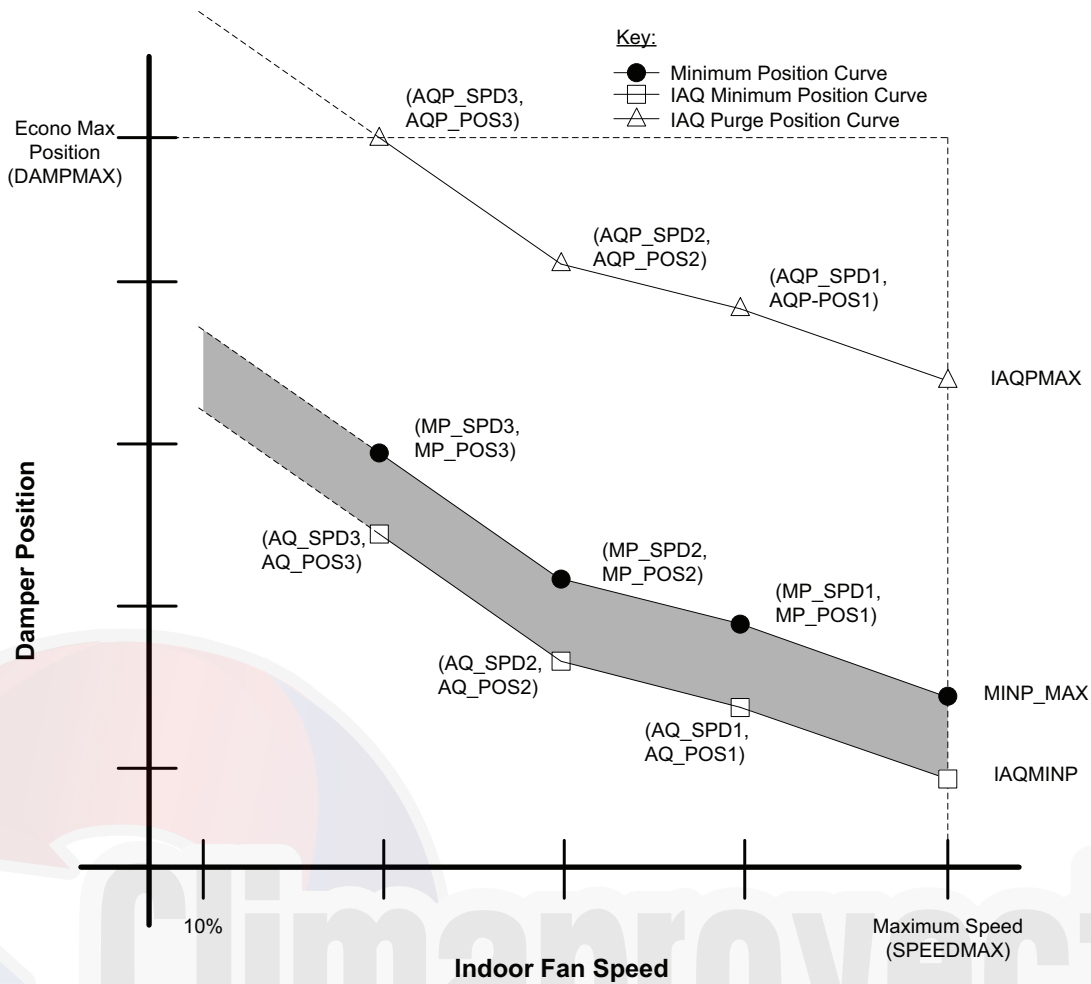

Fig. 19 — Minimum Damper Position Curves

FREE COOLING

The economizer will be enabled for cooling (**OK TO FREE COOL? = Yes**) if the supply air temperature sensor reading is valid, there are no applied lockouts, and economizer is operational. Economizer Operational (**ECON OPERATIONAL?**) indicates if an economizer is installed (**ECON INSTALLED?**) and feedback indicates it is operational. The three economizer lockouts that determine if free cooling should be used to help with cooling are: Dry Bulb Lockout (**DRYBULB LOCKOUT**), Enthalpy Lockout (**ENTHALPY LOCKOUT**), and Unoccupied Free Cooling Lockout (**UFC LOCKOUT?**). Any one of these lockouts will disable economizer free cooling. See below for how each lockout occurs.

When the economizer is available for free cooling (**OK TO FREE COOL? = Yes**) and the compression is not on, the damper will start opening from the damper's minimum Position in Effect (**EFFECTIVE MIN POS**) based on the supply air temperature (**SUPPLY AIR TEMP**) to provide free cooling. A low cooling demand (**DEMAND = LOW COOL**) will utilize the Low Free Cooling SAT Setpoint (**LOW COOL SAT SP**) as the Free Cooling Setpoint (**FREECOOL SAT SP**) to control the economizer. A medium or high cooling demand (**DEMAND = MED COOL** or **HIGH COOL**) will utilize the High Free Cooling SAT Setpoint (**HIGH COOL SAT SP**) as the Free Cooling Setpoint (**FREECOOL SAT SP**) to control the economizer.

During free cooling, the fan will start at the dedicated free cooling speed (**FREE COOL IDF SPD**). After the economizer (**ECON CMD POSITION**) reaches 100% (or Max) for 5 minutes, the fan will be changed to the High Cool Speed (**HIGH COOL IDF SPD**). When a high cooling demand (**DEMAND = HIGH COOL**) is active, the control will use the High Cool

Speed (**HIGH COOL IDF SPD**). The compressor will be allowed for use after the fan and economizer are 100% (or Max) for 5 minutes. Once compression is turned on, the economizer and fan will remain at 100% until the call for cooling is removed or until the unit is no longer allowed to free cool (**OK TO FREE COOL = No**).

Dry Bulb Lockout

Dry Bulb Lockout (**DRYBULB LOCKOUT**) occurs when any of the following are true:

- The Outdoor Air Temperature (**OUTDOOR AIR TEMP**) is invalid.
- When Differential Dry Bulb Control is disabled (**DIFF DRY BULB CTL = Disable**) and the Outdoor Air Temperature (**OUTDOOR AIR TEMP**) is greater than the configured Free Cooling Maximum Temperature (**FREE COOL MAX OAT**) or less than the configured Free Cooling Minimum Temperature (**FREE COOL MIN OAT**).
- When Differential Dry Bulb Control is enabled (**DIFF DRY BULB CTL = Enable**) and the return air temperature (**RETURN AIR TEMP**) plus the Differential Dry Bulb deadband (**DIFF DB DEADBAND**) is lower than the outdoor air temperature (**OUTDOOR AIR TEMP**).

Enthalpy Lockout

The control uses the Outdoor Air Temperature (**OUTDOOR AIR TEMP**), Outdoor Relative Humidity (**OARH LEVEL**), and Barometric Pressure (**BAROMETRIC PRESS**) to calculate the Outdoor Enthalpy (**OUTDOOR ENTHALPY**). The control uses the Return Air Temperature (**RETURN AIR TEMP**), Return Relative Humidity (**RARH LEVEL**), and Barometric Pressure (**BAROMETRIC PRESS**) to calculate the

Return Enthalpy (**RETURN ENTHALPY**). Enthalpy Lockout (**ENTHALPY LOCKOUT**) occurs when any of the following are true:

- When Differential Enthalpy Control is disabled (**DIFF ENTHALPY CTL = Disable**) and the outdoor enthalpy (**OUTDOOR ENTHALPY**) is greater than the Maximum Outdoor Enthalpy limit (**ENTHALPY HI LIMIT**).
- When Differential Dry Bulb Control is enabled (**DIFF DRY BULB CTL = Enable**) and the outdoor enthalpy (**OUTDOOR ENTHALPY**) is greater than the return enthalpy (**RETURN ENTHALPY**). The Differential Enthalpy deadband (**ENTHALPY DEADBAND**) is used in the case of unlocking the Enthalpy lockout (**ENTHALPY LOCKOUT**).
- The Enthalpy switch input (**ENTHALPY SWITCH**) is reading high.

Unoccupied Free Cooling Lockout

Unoccupied Free Cooling lockout (**UFC LOCKOUT?**) occurs when the unit is in the unoccupied period (**OCCUPIED NOW? = No**) and the Outdoor Air Temperature (**OUTDOOR AIR TEMP**) is less than the Unoccupied Free Cooling low temperature (**UFC LOW TEMP**).

UNOCCUPIED FREE COOLING

The unoccupied free cooling algorithm attempts to maintain the building space half way between the Occupied Cool Set Point (**OCC COOL SETPOINT**) and Occupied Heat Set Point (**OCC HEAT SETPOINT**) using only the economizer when the conditions in the building and the outdoors are suitable, during unoccupied periods. Three different points define this algorithm: Unoccupied Free Cooling configuration (**WHEN TO UNOCC FC**), Free Cooling Preoccupancy Time configuration (**UFC PREOCC TIME**), and Free cooling allowed (**OK TO FREE COOL?**).

WHEN TO UNOCC FC = 0 (Disabled)

Free Cooling will only occur if the space exceeds the unoccupied setpoints.

WHEN TO UNOCC FC = 1 (Preoccupancy)

Unoccupied free cooling can only occur when the time until the next occupied period is less than the Unoccupied Free Cool Pre-Occupancy Time (**UFC PREOCC TIME**) in minutes.

WHEN TO UNOCC FC = 2 (Unoccupied)

Unoccupied free cooling can occur throughout the entire unoccupied period. The space temperature must be higher than the mid-point between the occupied cooling and heating setpoints.

Power Exhaust

Power Exhaust is a function used to assist in the building exhaust air if the barometric relief damper is not enough. It can be one or two motors which can be controlled independently to provide 2 stages of exhaust. These two power exhaust stages are controlled by relays on the Main Base board, and therefore need to be configured on relay channels. To assign the channels set the **PE1 RELAY CHANNEL** and **PE2 RELAY CHANNEL** as needed.

NOTE: Factory installed power exhaust is only one channel and is on Relay 06.

When a power exhaust 1 relay channel is configured, the control will create a PE1 curve (see Fig. 20). This curve is created by applying the difference of the power exhaust stage 1 at maximum fan speed (**PE1 POS @ MAX SPD**) and the Economizer minimum at maximum fan speed (**MIN POS @ MAX FAN**) in relationship to the minimum position curve. When a power exhaust 2 relay channel is configured, the control will create a PE2 curve (see Fig. 20). This curve is created by applying the difference of the power exhaust stage 2 at maximum fan speed (**PE2 POS @ MAX SPD**) and the Economizer minimum at maximum fan speed (**MIN POS @ MAX FAN**) in relationship to the minimum position curve.

Power exhaust 1 (**PE1 RELAY**) and power exhaust 2 (**PE2 RELAY**) are controlled using their respective curves as a threshold. When the operating point of the Commanded Fan Speed (**IDF SPEED OUTPUT**) and Economizer Commanded Position (**ECON CMD POSITION**) is above the power exhaust 1 curve, Power exhaust 1 (**PE1 RELAY**) will be turned on. When the operating point falls below the curve minus the power exhaust turn off deadband (**PE OFF DEADBAND**), the Power exhaust 1 (**PE1 RELAY**) will be turned off. Power exhaust 2 operates the same as Power exhaust 1, except using the PE2 curve.

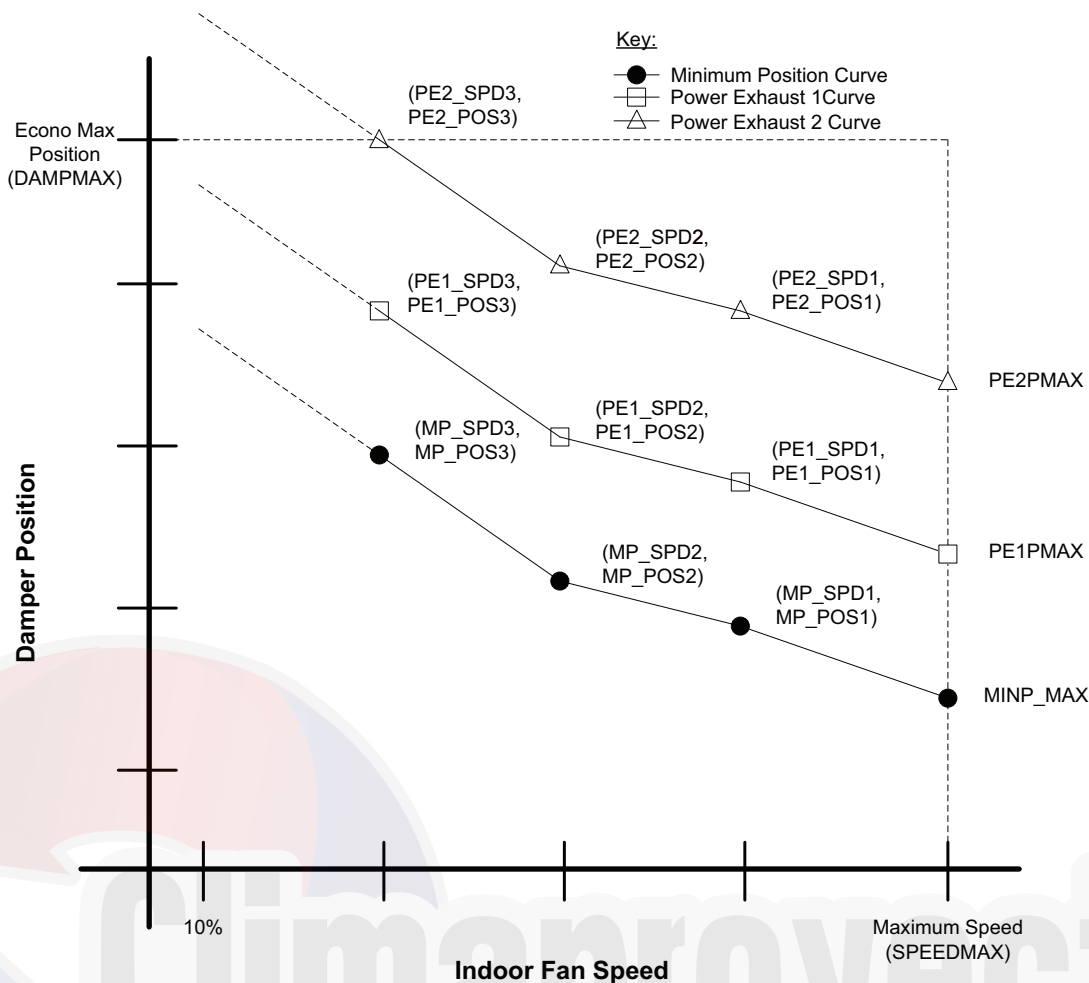

Fig. 20 — Power Exhaust Operation Curves

Indoor Air Quality (IAQ)

Indoor air quality is typically measured using a CO₂ sensor whose measurements are displayed in parts per million (ppm). Outdoor air quality may be measured with a CO₂ sensor for indoor-outdoor differential demand ventilation control. The factory-installed indoor air quality CO₂ sensor is mounted in the return section. A field-installed indoor air quality CO₂ sensor may be mounted in the return or in the occupied space. The indoor air quality modes of operation can be affected by the IAQ Analog Input Config (*ANALOG IAQ CTRL*) and other related and limit configurations as described below.

IAQ (ANALOG INPUT)

When IAQ assigned channel (*IAQ SENSOR CHAN*) is set for an analog input that input channel will be mapped to the Indoor Air Quality (*IAQ LEVEL*). The control is configured for indoor air quality sensors which provide 4 to 20 mA signal for 0 to 2000 ppm CO₂. If the sensor being used has a different range, the ppm display range must be reconfigured by entering new values for the IAQ Sensor Value at 4mA (*IAQ PPM @ 4MA*) and IAQ Sensor Value at 20mA (*IAQ PPM @ 20MA*).

ANALOG IAQ CTRL = 0 (No IAQ)

This signifies that there is no IAQ sensor installed. The economizer damper will operate based on the minimum position curve.

ANALOG IAQ CTRL = 1 (DCV)

During Demand Controlled Ventilation (DCV), the damper modulates on or between two ventilation curves depending upon the difference between the Indoor Air Quality (*IAQ LEVEL*) and the Outdoor Air Quality (*OAQ LEVEL*). The lower of these two curves is referred to as the IAQ Minimum

Position Curve, and the higher curve is the Minimum Position curve discussed in “Minimum Ventilation” on page 27 under Economizer Operation. Refer to that section on how the minimum Position curve is created. See Fig 19.

The IAQ Minimum Position curve is created by applying the difference of the IAQ position at maximum fan speed (*IAQ POS @ MAX SPD*) and the Economizer minimum at maximum fan speed (*MIN POS @ MAX FAN*) in relationship to the minimum position curve. The IAQ position at maximum fan speed (*IAQ POS @ MAX SPD*) should be set to an economizer position that brings in enough fresh air to remove contaminants and CO₂ generated by sources other than people. The Economizer minimum at maximum fan speed (*MIN POS @ MAX FAN*) should be set to an economizer position that brings in fresh air to remove contaminants and CO₂ generated by all sources including people when the indoor fan is operating at the IDF Maximum Fan Speed (*MAXIMUM IDF SPEED*). The Economizer minimum at maximum fan speed (*MIN POS @ MAX FAN*) value is the design value for maximum occupancy.

The economizer Min Position in Effect (*EFFECTIVE MIN POS*) will follow the IAQ Minimum Position curve while the Indoor Air Quality level (*IAQ LEVEL*) is less than the Outdoor Air Quality Level (*OAQ LEVEL*). The control will begin to open the damper more than the IAQ Minimum Position curve when the IAQ level begins to exceed the OAQ level by a configurable amount. This amount is referred to as AQ Differential Low (*LOW AIR.Q DIFF*). When the differential between IAQ and OAQ reaches AQ Differential High (*HIGH AIR.Q DIFF*), the economizer Min Position in Effect (*EFFECTIVE MIN POS*) will follow the Minimum Position Curve. When the IAQ/OAQ differential is between AQ Differential Low (*LOW AIR.Q DIFF*) and AQ Differential High

(**HIGH AIR.Q DIFF**), the control will modulate the damper between the IAQ Minimum Position Curve and the Minimum Position Curve in a linear manner as shown as the shaded area in Fig. 19. Figure 21 shows the Min Position in Effect (**EFFECTIVE MIN POS**) relationship while the Commanded Fan Speed (**ECON CMD POSITION**) is held at the maximum speed.

ANALOG IAQ CTRL = 2 (Override IAQ)

Override IAQ is reserved for a future release.

ANALOG IAQ CTRL = 3 (Control Minimum Position)

An external 4 to 20 mA source is used to set the Min Position in Effect (**EFFECTIVE MIN POS**). The 4mA signal corresponds to 0% and the 20 mA signal corresponds to 100%. In this mode, configuration such as Economizer minimum at maximum fan speed (**MIN POS @ MAX FAN**), IAQ position at maximum fan speed (**IAQ POS @ MAX SPD**) and the economizer minimum position and DCV minimum position curves in Fig. 19 and Fig. 21 are not used. If the indoor fan is not operating, the economizer position will be zero. The actual damper position may exceed the economizer Min Position in Effect (**EFFECTIVE MIN POS**) to provide economizer cooling.

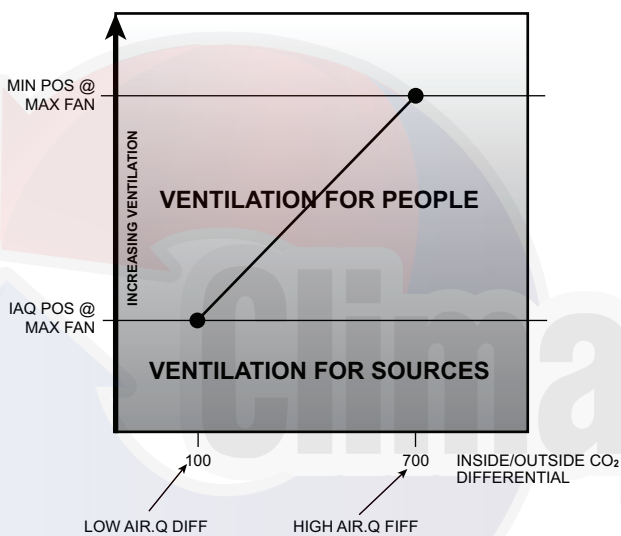

Fig. 21 — IAQ Minimum Position Curve

OUTDOOR AIR QUALITY (ANALOG INPUT)

The default for the Outdoor Air Quality (**OAQ LEVEL**) is 400 ppm CO₂ when the OAQ sensor is not assigned an input channel. When OAQ Assigned channel (**OAQ SENSOR CHAN**) is set for an analog input, that input channel will be mapped to the Outdoor Air Quality (**OAQ LEVEL**). The outdoor air quality sensor provides a 4 to 20 mA signal corresponding to 0 to 2000 ppm CO₂. If a field supplied sensor has a different range, the ppm display range must be reconfigured by entering new values for the OAQ Sensor Value at 4mA (**OAQ PPM @ 4MA**) and OAQ Sensor Value at 20mA (**OAQ PPM @ 20MA**).

Pre-occupancy Purge

The control has the option for a pre-occupancy purge to refresh the air in the space prior to occupancy. This feature is enabled by setting **PREOCC PURGE ENBL** to Yes. This function is also referred to as the IAQ purge function.

The IAQ Purge will operate under the following conditions:

- Purge is enabled
- the unit is in the unoccupied state
- Current Time is valid
- Next Occupied Time is valid

- time is one hour prior to next occupied period
- the OAT is greater than the lockout (**PREOCC LOW LIMIT**)

The IAQ Purge Position curve is created by applying the difference of the IAQ purge position at maximum fan speed (**PURGE POS @ MAX**) and the Economizer minimum at maximum fan speed (**MIN POS @ MAX FAN**) in relationship to the minimum position curve. The IAQ purge position at maximum fan speed (**PURGE POS @ MAX**) should be set to an economizer position that brings in enough fresh air over an hour period to remove contaminants and CO₂ during the unoccupied period. When the preoccupancy purge function is active (**IN PREOCC PURGE?**), the economizer Min Position in Effect (**EFFECTIVE MIN POS**) will follow the IAQ Purge Position curve.

Temperature Compensated Start

Space control set points are usually set to 2 different levels for unoccupied period and occupied period. Unoccupied set points saves energy, while occupied set points provide occupant comfort. The time period it takes for the RTU to bring the space from its current condition in unoccupied mode to its occupied set point is referred to as start bias time, or bias time. The algorithm to calculate this bias time is called Temperature Compensated Start. This is required for ASHRAE 90.1 compliance. When temperature compensated start is running (**TCS ACTIVE?**) the control uses the occupied set points to control the space.

When Temperature compensated start is enabled (**ADAPTIVE TCS?**), no other configuration parameters are needed for this algorithm, because the algorithm will automatically adjust the Bias Time based on the data collected during the period of last time optimal start. The inputs to the calculation algorithm includes space temperature, unoccupied set points, occupied set points, outdoor air temperature, and supply air temperature. Bias time is changed dynamically per RTU operation.

When Temperature compensated start is disabled (**ADAPTIVE TCS?**), the control will use the User Temperature compensated Start bias time (**USER TCS BIAS TIME**) in determining when to start controlling to the occupied set points. If the User Temperature compensated Start bias time (**USER TCS BIAS TIME**) is set to zero, the control will switch to the occupied setpoints at the time of occupancy.

Linkage

The SystemVu™ controller will support 3V™, VAV and VVT® zoning system on a CCN system or Open VVT and VAV systems on a BACnet MS/TP System. All that is required is to configure the Open or 3V Master zone to use the SystemVu rooftop unit as its airsource. The SystemVu control will need to be configured for the proper network protocol (**BAS PROTOCOL**) and set for Space Sensor Control (**UNIT CTRL TYPE**). The SystemVu controller will reply to the zoning system and change its operating parameters to meet the demand of the zoning system. Status of this process can be viewed in the airside linkage tab of the property pages in the i-Vu® application or by viewing the linkage maintenance table with a CCN tool.

Carrier Comfort Network® (CCN) Operation

The SystemVu controller can be configured to connect to a CCN system. The SystemVu controller has one RS-485 BMS port that can be configured from the local display for BACnet or CCN. The BMS configuration parameters can be found in the **SETTINGS** → **NETWORK SETTINGS** submenu. The first configuration is the BMS system for CCN systems change this configuration from BACnet to CCN then set the CCN BAUD rate, the bus and element number and you will be able to find the controller with any CCN tool then upload the CCN tables in the controller for use by the tool.

BACnet Network Operation

The SystemVu™ controller is ready to connect to BACnet. The SystemVu controller has one RS-485 BMS port that can be configured from the local display for BACnet or CCN. The default setting is BACnet and the Default BACnet Baud rate is 76800. These settings are found on the **SETTINGS** → **NETWORK SETTINGS** sub menu of the local display. There are four other settings for i-Vu® compatibility and for setting the device ID and MAC address of the controller. See Table 15 for assistance.

Before connecting to the BACnet system, determine the system requirements and use the following guide to configure the BACnet settings. Then power the controller down, connect to the BACnet MS/TP network, and locate the controller.

For i-Vu systems with auto addressing desired the controller is already set with the defaults from the factory ready to connect to this type of system; just set the MAC address of the controller from 0 to 99 and then power down and connect to the network. The router will find and send the network number to the controller and the controller will set it device ID with the network base appended by the Mac address.

For i-Vu and other BACnet systems, when it is required to send the device ID to the controller, change the ALC/i-Vu auto ID scheme to no and set the MAC address from 0 to 99 like before. Then connect to the network and write the device ID to the controller at the MAC address previously set. The controller will accept and retain the device ID written to the device ID property of the object ID.

To manually set the device ID from the local display, set the BACnet auto/manual to manual. This allows use of the full range of 1 to 127 for the MAC address and set the device ID in the BACnet ID selection of the local display. It can only be set from the local display and will not accept a write to the device ID property in the object ID.

Table 15 — BACnet and i-Vu Settings

BACNET ID AUTO/MANUAL	i-VU AUTO SCHEME	HOW DEVICE IS DERIVED	MAC RANGE
Manual	ON or OFF	Local display BACnet ID-BACnet writes not allowed	0-127
Auto	OFF	Device ID Prefix + Mac - BACnet writes allowed	0-99
Auto	ON	Device ID Prefix + MAC (prefix updated by color cache) - BACnet writes not allowed	0-99

Alarm Handling

There are a variety of different alerts and faults in the system, the term alarm is used to reference alerts and faults. Alerts are indicated by AXXX (where XXX is the alert number) on the display and generally signify a warning of some sort or the improperly functioning circuit can restart without human interaction. If an fault occurs, indicated by FXXX (where XXX is the fault number), a major function of the unit is inoperable or the damaged circuit will generally not restart without an alarm reset via the display or CCN.

The response of the control system to various alerts and faults depends on the seriousness of the particular alert or fault. In the mildest case, an alert does not affect the operation of the unit in any manner. An alert can also cause a “strike.” A “striking” alert will cause the circuit to shut down for 15 minutes. This feature reduces the likelihood of false alarms causing a properly working system to be shut down incorrectly. If three strikes occur before the circuit has an opportunity to show that it can function properly, the circuit will strike out, causing the shutdown fault for that particular circuit. Once activated, the shutdown fault can only be cleared via an alarm reset.

However, circuits with strikes will be given an opportunity to reset their strike counter to zero. As discussed above, a strike

typically causes the circuit to shut down. Fifteen minutes later, that circuit will once again be allowed to run. If the “troubled” circuit runs continuously for a user defined time (**SETTINGS** → **UNIT CONFIGURATIONS** → **COOLING** → **STRIKE CLEAR TIME**) with no detectable problems, the strike counter will be reset to zero. Default value is 5 minutes.

ALARM RELAY OUTPUT

The alarm relay output is a configurable normally open 24 VAC output defaulted to relay 11 on the Main Base Board (MBB) TB2 connector. Selection of which alerts and faults will result in closing of the alarm relay may be set in the Alarm Relay Configuration (**SETTINGS** → **UNIT CONFIGURATIONS** → **ALARM RELAY**). Setting a configuration to YES will result in the alarm output relay to energize when that particular condition is in an alarm state. Setting a configuration to NO will result in no action by the alarm output relay for that particular condition.

NOTE: An accessory filter switch can be used along with the alarm relay output function to indicate dirty filter service need. See the Troubleshooting section for more information on viewing, diagnosing, and clearing alerts and alarms.

TROUBLESHOOTING

The SystemVu™ display shows actual operating conditions of the unit while it is running. If there are alarms or there have been alarms, they will be displayed in either the active faults, active alerts, or the history alarm list (see Table 16 starting on page 38). Service Test mode allows proper operation of the compressors, fans, and other components to be checked while the unit is not operating. See “SERVICE TEST” on page 12.

Complete Unit Stoppage

There are several conditions that can cause a complete unit stoppage, including:

- A fault is active which causes the unit to shut down.
- Cooling and heating loads are satisfied.
- Programmed occupancy schedule.
- General power failure.
- Tripped 24-volt transformer circuit breakers.
- Blown fuse or circuit breakers
- Unit is turned off through the network.

Restart Procedure

Before attempting to restart the machine, check the faults and alerts list to determine the cause of the shut down. If the shutdown fault for a particular control function has occurred, determine and correct the cause before allowing the unit to run under its own control again. When there is a problem, the unit should be diagnosed in Service Test mode. The faults must be reset before the control function can operate in either Normal mode or Service Test mode.

Faults and Alerts

VIEWING AND CLEARING UNIT ALARMS

Presence of active alarms will be indicated on the SystemVu display by the Alarm Status lights. When alerts are active, the yellow “ALERT” light will be lit. When faults are active, the red “FAULT” light will be lit. When the unit is operational, then green “RUN” light will be lit. The SystemVu controller standby screen will be updated with the active alarms for easy access. Presence of active alarms may also be signaled on the Alarm Output terminals. Each alarm may also be broadcast on the CCN network. Active alarms and past alarm history can be reviewed and cleared via the local display or a network device. The following menu locations are used for the local display.

ACTIVE FAULTS

Displays the list of active faults in order of occurrence.

ACTIVE ALERTS

Displays the list of active alerts in order of occurrence.

HISTORY

Displays the list of active and previously active faults and alerts in order of occurrence with time and date.

RESET FAULTS/ALERTS

User command to manually reset faults and alerts.

Each alarm can have up to 3 data points stamped along with date and time to assist in troubleshooting. Pressing ENTER on the alarm or expanded screen will provide these data points.

DIAGNOSTIC ALARM CODES AND POSSIBLE CAUSES

Fault F010 – MBB LOW VOLTAGE

This fault occurs when the MBB supply voltages falls below 17 volts AC. When this occurs, the control will shut down the unit. This will automatically clear when the supply voltage rises above 19 volts AC. The cause of this fault is usually a brownout condition, low supply voltage, or supply power missing a phase.

Fault F011 – MBB REFERENCE VOLTAGE

This fault occurs when the MBB internal microprocessor's DC reference voltages is out of range. When this occurs, the control will shut down the unit. This will automatically clear when the DC reference voltage goes back in range. The cause of this fault is usually a MBB failure or supply voltage out of range.

Alert A012 – MBB ZERO CROSSING

This fault occurs when the MBB supply voltage frequency is out of range. When this occurs, the control will issue an alert. This will automatically clear when the supply voltage goes back in range. The cause of this fault is usually a MBB failure or supply voltage frequency to high or to low.

Fault F013 – MBB FUSE 2 OPEN

This fault occurs when the MBB's internal fuse number 2 exceeds threshold temperature. When this occurs, the control will shut down the unit. This will automatically clear when the fuse temperature gets back in range. The cause of this fault is usually a switch input has a wiring error (short) or the switch pulled too much current. Discrete input number 2, Fire Shutdown input, and the IGC fan request are connected to fuse 2.

Fault F014 – MBB FUSE 3 OPEN

This fault occurs when the MBB's internal fuse number 3 exceeds threshold temperature. When this occurs, the control will shut down the unit. This will automatically clear when the fuse temperature gets back in range. The cause of this fault is usually a switch input has a wiring error (short) or the switch pulled too much current. Configurable discrete input numbers 12, 13, and 14 are connected to fuse 3.

Alert A015 – MBB RNET VOLTAGE RANGE

This fault occurs when the MBB's Rnet 12 volt output is out of range. When this occurs, the control will issue an alert, and any accessory connected to the Rnet plug may not operate properly. This will automatically clear when the voltage goes back in range. The cause of this fault is usually a MBB failure or supply voltage out of range.

Alert A016 – MBB 24VDC RANGE

This fault occurs when the MBB's 24vdc output falls below 17 volts DC. When this occurs, the control will put the Analog Input number's 6, 7, and 8 into error state. This will automatically clear when the voltage rises above 19 volts DC. The cause of this fault is usually a MBB failure or supply voltage out of range.

Alert A017 – MBB 5VDC RANGE

This fault occurs when the MBB's 5vdc output falls below 4.5 volts DC. When this occurs, the control will put the Transducer inputs into error state. This will automatically clear when the voltage rises above 4.5 volts DC. The cause of this fault is usually a MBB failure or supply voltage out of range.

Fault F018 – MBB EEPROM FAILURE

The unit will completely shut down. The serial EEPROM chip on the MBB which stores the unit's configuration is not responding. Recovery is automatic but MBB board replacement may be necessary. Cycling the power to the control should be tried before board replacement.

Alert A019 – MBB CLOCK FAILURE

The alert occurs when the RTC clock chip on the MBB is not responding. Time and date functions, such as local occupancy schedules, will not operate. The unit will default to 24/7 unoccupied mode. Recovery is automatic but MBB board replacement may be necessary. Cycling power to the control and reconfiguring the time and date should be tried before board replacement.

Fault F020 – SOFTWARE ERROR

The unit will completely shut down. The software on the MBB is not responding. Recovery is automatic if the software is able to reset the board but software change may be necessary. Cycling the power to the control should be tried before board replacement.

Alert A099 – COMM LOSS WITH SIOB

This alert occurs when there has been a loss of communication with the IO Board on the LEN bus. Any sensor inputs from the board will be ignored and outputs will no longer be controlled.

Alert A100 – SAT SENSOR FAILURE

This alert occurs when the fan supply temperature sensor is in an error state. Economizer cooling cannot occur while this alert is active. The unit will not be able to honor SAT limits. This alert resets automatically. The cause of the alert is usually a faulty thermistor, a shorted or open thermistor caused by a wiring error, or a loose connection.

Alert A101 – FST SENSOR RANGE

This alert occurs when the fan supply temperature sensor is outside the range -40°F to 245°F (-40°C to 116°C). This alert resets automatically. The cause of the alert is usually a faulty thermistor, a shorted or open thermistor caused by a wiring error, or a loose connection.

Alert A102 – FST OPEN SENSOR

This alert occurs when the fan supply temperature sensor reads as an open circuit. This alert resets automatically. The cause of the alert is usually a faulty thermistor or an open thermistor caused by a wiring error, or a loose connection.

Alert A103 – FST SHORTED SENSOR

This alert occurs when the fan supply temperature sensor reads as a short circuit. This alert resets automatically. The cause of the alert is usually a faulty thermistor or a shorted thermistor caused by a wiring error, or a loose connection.

Alert A104 – OAT SENSOR RANGE

This alert occurs when the outdoor air temperature is outside the range -40°F to 245°F (-40°C to 116°C). All ambient temperature lockout limits for cooling and heating are ignored. All cooling control logic will assume OAT is high. For economizer equipped units, the economizer will not operate to provide cooling. The economizer will still operate for ventilation. The control will use normal operation for outdoor fan control. For units with CCH crankcase heat relay control, the crankcase heat relay will be turned on if any compressor is off. This alert resets automatically. The cause of the alert is usually a faulty thermistor, a shorted or open thermistor caused by a wiring error, or a loose connection.

Alert A105 – OAT OPEN SENSOR

See Alert A104.

Alert A106 – OAT SHORTED SENSOR

See Alert A104.

Alert A107 – RAT SENSOR RANGE

This alert occurs when the return air temperature is outside the range –40°F to 245°F (–40°C to 116°C). Differential dry bulb crossover control can not occur. Free cooling can only be controlled by the OAT and enthalpy switch. The economizer mechanically disconnected alert will not be diagnosed. This alert resets automatically. The cause of the alert is usually a faulty thermistor, a shorted or open thermistor caused by a wiring error, or a loose connection.

Alert A108 – RAT OPEN SENSOR

See Alert A107.

Alert A109 – RAT SHORTED SENSOR

See Alert A107.

Alert A110 – SPT SENSOR RANGE

This alert occurs when the temperature is outside the range –40°F to 245°F (–40°C to 116°C). Cooling and heating will not operate. For economizer equipped units, the economizer will still operate for ventilation. This alert resets automatically. The cause of the alert is usually a faulty thermistor in the T-55, T-56, or T-58 device, a shorted or open thermistor caused by a wiring error, or a loose connection.

Alert A111 – SPT OPEN SENSOR

See Alert A110.

Alert A112 – SPT SHORTED SENSOR

See Alert A110.

Alert A130 – CIR.A SSP SENSOR RANGE

This alert occurs when the pressure is outside the range –6.7 psig to 420 psig. A circuit cannot run when this alert is active. The cause of the alert is usually a faulty transducer, faulty 5-v power supply, or a loose connection. Use Table 25 on page 51 to determine where the error is introduced.

Alert A131 – CIR.A SSP OPEN SENSOR

See Alert A130.

Alert A132 – CIR.A SSP SHORT SENSOR

See Alert A130.

Alert A133 – CIR.A SDP SENSOR RANGE

This alert occurs when the pressure is outside the range 14.5 psig to 667 psig. A circuit cannot run when this alert is active. The cause of the alert is usually a faulty transducer, faulty 5-v power supply, or a loose connection. Use Table 25 on page 51 to determine where the error is introduced.

Alert A134 – CIR.A SDP OPEN SENSOR

See Alert A130.

Alert A135 – CIR.A SDP SHORT SENSOR

See Alert A130.

Alert 150 – OACFM OPEN SENSOR

This alert occurs when the Outdoor Air CFM sensor input is 0 mA and the sensor is configured and installed. Check sensor and wiring. This alert clears automatically.

Alert 151 – OACFM SHORTED SENSOR

This alert occurs when the Outdoor Air CFM sensor input shorted and the sensor is configured as installed. Check sensor and wiring. This alert clears automatically.

Alert A160 – OARH OPEN SENSOR

This alert occurs when the Outdoor Air Relative Humidity sensor input is 0 mA and the sensor is configured as installed. Outside Air Enthalpy cannot be calculated, therefore no enthalpy crossover can be used and only dry bulb will be used in

determining free cooling. Check sensor and wiring. This alert clears automatically.

Alert A161 – OARH SHORTED SENSOR

This alert occurs when the Outdoor Air Relative Humidity sensor input shorted and the sensor is configured as installed. Outside Air Enthalpy cannot be calculated; therefore, no enthalpy crossover can be used and only dry bulb will be used in determining free cooling. Check sensor and wiring. This alert clears automatically.

Alert A162 – RARH OPEN SENSOR

This alert occurs when the Return Air Relative Humidity sensor input is 0 mA and the sensor is configured as installed. Return Air Enthalpy cannot be calculated; therefore, no differential enthalpy crossover can be used. Dry bulb and single enthalpy will be used in determining free cooling. Check sensor and wiring. This alert clears automatically.

Alert A163 – RARH SHORTED SENSOR

This alert occurs when the Return Air Relative Humidity sensor input shorted and the sensor is configured as installed. Return Air Enthalpy cannot be calculated; therefore, no differential enthalpy crossover can be used. Dry bulb and single enthalpy will be used in determining free cooling. Check sensor and wiring. This alert clears automatically.

Alert A164 – IAQ OPEN SENSOR

This alert occurs when the IAQ input is 0 mA and the sensor is configured as installed. IAQ operation will be disabled. Check sensor and wiring. This alert clears automatically.

Alert A165 – IAQ SHORTED SENSOR

This alert occurs when the IAQ input is shorted and the sensor is configured as installed. IAQ operation will be disabled. Check sensor and wiring. This alert clears automatically.

Alert A166 – OAQ OPEN SENSOR

This alert occurs when the OAQ input is 0 mA and the sensor is configured as installed. OAQ operation will be disabled. Check sensor and wiring. This alert clears automatically.

Alert A167 – OAQ SHORTED SENSOR

This alert occurs when the OAQ input is shorted and the sensor is configured as installed. OAQ operation will be disabled. Check sensor and wiring. This alert clears automatically.

Alert A168 – SPACE RELATIVE HUMIDITY OPEN SENSOR

This alert occurs when the SPRH input is 0 mA and the sensor is configured as installed. Check sensor and wiring. This alert clears automatically.

Alert A169 – SPACE HUMIDITY SHORTED SENSOR

This alert occurs when the SPRH input is shorted and the sensor is configured as installed. Check sensor and wiring. This alert clears automatically.

Alert A170 – ECON FEEDBACK RANGE

This alert occurs when the Economizer analog feedback signal is outside the range of 1.3vdc to 10.3vdc and the feedback is configured to use. A short is 10.5vdc and an open circuit is less than 0.1vdc. Economizer diagnostics operation will be disabled. This is usually caused by a wiring problem, actuator failure, or the wrong actuator. Investigate using the Low Voltage schematics in Fig. 24-28 ; make sure the feedback signal from the actuator is correct. This alert clears automatically.

Alert A171 – ECON FEEDBACK OPEN

See Alert A170.

Alert A172 – ECON FEEDBACK SHORTED

See Alert A170.

Alert A190 – TSTAT HEAT/COOL CALLS

This alert occurs in Thermostat mode when Y1, Y2, or Y3 is energized simultaneously with W1 or W2. Verify thermostat and thermostat wiring. The software will enter either the

cooling or heating mode depending upon which input turned on first. This alert resets automatically when Y1, Y2, and Y3 are not on simultaneously with W1 and W2.

Alert A191 – TSTAT IMPROPER COOL

This alert occurs in Thermostat mode when Y2 or Y3 is energized and Y1 is not. Verify thermostat and thermostat wiring. When this occurs, the control will treat the inputs as a number instead of specific input. Example a Y2 and Y3 would mean 2 cooling inputs so the control would treat that as is a Y1 and Y2 was active. This alert resets automatically when Y1 is turned On.

Alert A192 – TSTAT IMPROPER HEAT

This alert occurs in Thermostat mode when W2 is energized and W1 is not. Verify thermostat and thermostat wiring. When W2 turns On, the software will behave as if W1 and W2 are both On. When W2 turns Off, the software will behave as if W1 and W2 are both Off. This alert resets automatically when W1 is turned On.

Fault F200 – FIRE SHUTDOWN

This fault occurs when the fire shutdown input is either open or closed, depending upon its configuration. This fault is usually caused by an auxiliary device that is trying to shut down the unit, e.g., smoke detector. This will cause a unit shutdown condition. Verify that the configuration is set correct, verify the wiring and auxiliary device. This fault resets automatically.

Fault F201 – CONDENSATE OVERFLOW

This fault occurs when the COFS input is either open or closed depending upon its configuration. This fault is usually caused by water reaching a high level in the drain pan. This will cause a cooling lockout. Verify that the configuration is set correct, verify the wiring and auxiliary device. This fault resets automatically.

Alert A203 – DIRTY FILTER

This alert occurs when the Filter Status switch senses a plugged filter for 5 continuous seconds after the indoor fan has been running for 10 seconds or if the fan has run for longer than the change filter time. Because the Dirty Air Filter switch can be configured normally opened or closed, the switch might be open or closed. Verify that the configurations are set correct, verify the wiring and filter status switch. The hose should be connected to the low side of the switch. The alert resets automatically if it was tripped due to the filter switch. If the alert is tripped because of the timer, it will need to be reset after the filter has been replaced or inspected. Rest the time with the **RESET FILTER TIME** point located under **RUN STATUS** → **GENERAL** or **INPUTS** → **GENERAL INPUTS**.

Fault F204 – REMOTE SHUTDOWN

This fault occurs when the remote shutdown input is either open or closed, depending upon its configuration and configured to set a fault. This fault is usually caused by an auxiliary emergency device that is trying to shut down the unit. This will cause a unit shutdown condition. Verify that the configuration is set correct, verify the wiring and auxiliary device. This fault resets automatically.

Alert A210 – GENERAL STATUS

This alert occurs when the general status input is either open or closed, depending upon its configuration and configured to set a alert. This alert is usually caused by an auxiliary switch device that is trying to send a warning about the unit. Verify that the configuration is set correct, verify the wiring and auxiliary device. This alert resets automatically.

Fault F211 – GENERAL STATUS

This fault occurs when the general status input is either open or closed, depending upon its configuration and configured to set a fault. This fault is usually caused by an auxiliary switch device that is trying to shut down the unit. This will cause a unit shutdown condition. Verify that the configuration is set correct, verify the wiring and auxiliary device. This fault resets automatically.

Fault F310 – CIRA DOWN DUE TO FAIL

This fault occurs when both compressors on circuit A have 3 strikes. Investigate the alerts that caused the strikes to occur, and correct or test as needed. Manual alarm reset or power cycle is required to reset this fault.

Fault F311 – CIRA LOW CHARGE

This alert occurs when the compressors are off and both the discharge and suction pressure are less than the low charge level (**LOW CHARGE LEVEL**) and OAT is greater than the low charge limit (**NO LOW CHARGE OAT**). The cause of the alert is usually low refrigerant pressure or faulty pressure transducers. This alert only occurs when the compressor is OFF because the low refrigerant pressure alert will handle this situation when the compressor is operating. Manual alarm reset or power cycle is required to reset this fault.

Alert A312 – CIRA UNEXPECTED OFF

These alerts occur when the suction pressure raises the configured amount and the pressure ratio drop the configured amount both in a 10 second window during compressor operation. When this occurs, the control turns off the compressors and logs a strike for the compressor that was on. This alerts reset automatically. The possible causes are: high-pressure switch (HPS) open (the HPS is wired in series with compressor relays on the MBB), compressor internal protection is open, or a wiring error (a wiring error might not allow the compressor to start).

Alert A313 – CIRA HIGH DISCHARGE

This alert occurs when the discharge pressure is greater than the configured **CIRA SDP LIMIT** amount. This alert resets automatically when the pressure falls 20 psig below the threshold. When running both compressors, the control will remove A1 and add a strike to it. The control will also set the ODFs to the high cool speed. The cause of the alert is usually an overcharged system, high outdoor ambient temperature coupled with dirty outdoor coil, plugged filter drier, or ODF speeds being set too low.

Alert A314 – CIRA HPS TRIP

This alert occurs when the discharge high pressure switch opens. This alert resets automatically when the pressure falls below the switch threshold and the switch closes for 3 minutes. The control will add a strike for which ever compressors were on. The control will also set the ODFs to the high cool speed. The cause of the alert is usually an overcharged system, high outdoor ambient temperature coupled with dirty outdoor coil, plugged filter drier, or ODF speeds being set too low.

Alert A315 – CIRA LOW DISCHARGE

This alert occurs when the discharge pressure is less than the OAT plus the configured **LOW DISCHARGE LEV** amount. This alert resets automatically. The control will add a strike for whichever compressors were on. The cause of the alert is usually an undercharged system, low outdoor ambient temperature coupled with dirty outdoor coil, plugged filter drier, or ODF speeds being set too high.

Alert A316 – CIRA LOW SUCTION

This alert occurs when the compressor is operating and the evaporating temperature (converted from the suction pressure) is less than configured low suction control levels, **LOW SUC LEVEL 1**, **LOW SUC LEVEL 2**, or **LOW SUC LEVEL 3**. The circuit SST value must be less than **LOW SUC LEVEL 1** (for 5 minutes), **LOW SUC LEVEL 2** (for 4 minutes), or **LOW SUC LEVEL 3** (for 3 minutes when using the economizer and 1.5 minutes when not using the economizer) for the alert to occur. When the outdoor temperature is less than 40°F, the above values are reduced 1°F for every 2°F OAT is below 40°F. All the above timers will reset if the suction temperature rises above **LOW SUC OK TEMP** for 1 minute. This alert causes a strike for the respective circuit. This alert will activate when the coil becomes frosted. However, during the 15 minute reset

period, the coils will thaw and the strike should clear and restart if there is nothing else wrong with the circuit. The alert resets automatically. The cause of the alert is usually low refrigerant charge, dirty filters, evaporator fan operating backwards, loose or broken belt, plugged filter drier, faulty transducer, excessively cold return air, or stuck open economizer when the ambient temperature is low.

Alert A317 – CIR.A PRESSURE RATIO

This alert occurs when the Circuit A pressure ratio is less than the configured **MIN PRESSURE RATIO** amount. This alert resets automatically. The control will add a strike for whichever compressors were on. The cause of the alert is usually an undercharged system, low outdoor ambient temperature coupled with dirty outdoor coil, plugged filter drier, or ODF speeds being set too high.

Fault F318 – COMPRESSOR STUCK ON

This alert occurs when the suction pressure does not raise the minimum suction amount (**CIR.A MIN SUC.P**) and the ratio did not fall at least the off pressure ratio (**OFF P.RATIO**). When this occurs, the control turns off all of the compressors, and enters a safety shutdown condition. The possible causes are a welded contactor or frozen compressor relay on MBB. Manual alarm reset or power cycle is required to reset this fault.

Fault F319 – C.A1 DOWN DUE TO FAIL

This fault occurs when compressor A1 has 3 strikes. Investigate the alerts that caused the strikes to occur, and correct or test as needed. Manual alarm reset or power cycle is required to reset this fault.

Alert A320 – C.A1 REVERSE ROTATION

This alert occurs when 10 seconds after the compressor turns on, the suction rose and the discharge pressure dropped. This alert causes a strike for the compressor. The alert resets automatically. The cause of the alert is usually compressor wiring causing reverse rotation or a faulty compressor.

Alert A321 – C.A1 FAIL TO PRESSURE

This alert occurs when 10 seconds after the compressor turns on, the suction did not drop more than suction amount (**CIR.A MIN SUC.P**) and discharge pressure did not rise more than discharge amount (**CIR.A MIN DIS.P**). This alert causes a strike for the compressor. The alert resets automatically. The cause of the alert is usually compressor wiring causing reverse rotation or a faulty compressor.

Fault F322 – C.A2 DOWN DUE TO FAIL

This fault occurs when compressor A2 has 3 strikes. Investigate the alerts that caused the strikes to occur, and correct or test as needed. Manual alarm reset or power cycle is required to reset this fault.

Alert A323 – C.A2 REVERSE ROTATION

This alert occurs when 10 seconds after the compressor turns on, the suction rose and the discharge pressure dropped. This alert causes a strike for the compressor. The alert resets automatically. The cause of the alert is usually compressor wiring causing reverse rotation or a faulty compressor.

Alert A324 – C.A2 FAIL TO PRESSURE

This alert occurs when 10 seconds after the compressor turns on, the suction did not drop more than suction amount (**CIR.A MIN SUC.P**) and discharge pressure did not rise more than discharge amount (**CIR.A MIN DIS.P**). This alert causes a strike for the compressor. The alert resets automatically. The cause of the alert is usually compressor wiring causing reverse rotation or a faulty compressor.

Alert A410 – IGC IGNITION FAILURE

This alert occurs when the IGC fan request does not activate 15 minutes after turning heat 1 on when configured for Gas Heat. The control will lockout all the heat stages. This alert

will automatically reset after the IGC fan request occurs. The cause of this alert is usually faulty wiring of the IGC, no gas flow, or wrong configuration.

Fault F411 – ROLLOUT WITHOUT HEAT

This fault occurs when the IGC fan request activates and the heat has been off for at least 3 minutes when configured for Gas Heat. The control will enter the safety shutdown condition. This alert will automatically reset after the IGC fan request turns off for 10 minutes. The cause of this alert is usually faulty wiring of the IGC, or rollout switch trip without a heat call.

Fault F412 – RUNAWAY HEAT

This fault occurs when the SAT rises above the maximum SAT. The control will enter the safety shutdown condition. This alert will automatically reset after if configured to and the SAT falls 50°F below the maximum SAT. The cause of this alert is usually heat stuck on causing high SAT, or low air flow.

Alert A510 – INDOOR FAN STATUS

This alert occurs when the unit is configured not to shut down on fan status and either the fan is requested off and the fan speed feedback does not reach zero in the VFD deceleration time or the fan is requested greater than zero and the fan speed feedback does not reach that speed in the VFD acceleration time. This alert will reset automatically. The cause of this alert is usually broken belt, motor failure, or configuration error.

Fault F511 – IDF OFF WHEN COMMAND ON

This fault occurs when the unit is configured to shut down on fan status, the fan is requested greater than zero, and the fan speed feedback does not reach that speed in the VFD acceleration time. The cause of this alert is usually Fan stuck on, or Configuration incorrect. Manual alarm reset or power cycle is required to reset this fault.

Fault F512 – IDF ON WHEN COMMAND OFF

This fault occurs when the unit is configured to shut down on fan status, the fan is requested off, and the fan speed feedback does not reach zero in the VFD deceleration time. The cause of this alert is usually tripped circuit breaker, broken belt, bad indoor fan motor, or configuration incorrect. Manual alarm reset or power cycle is required to reset this fault.

Fault F600 – IDF VFD COMMUNICATION

This fault occurs when the indoor fan VFD and the SystemVu™ control are not communicating properly. This will cause a unit shutdown, and will automatically reset when communication is properly restored. The cause of this is usually a break in the communication connection, noise on the LEN bus, wiring error, or a configuration error. Verify VFD configurations are set per the latest literature.

Fault F601 – IDF VFD UNEXPECTED

This fault occurs when the indoor fan VFD informs the SystemVu control that it has an active fault. This will cause a unit shutdown, and will automatically reset when the VFD fault is cleared but likely will require a manual reset to reset the VFD. Refer to the VFD section or literature for details on the specific VFD fault. Verify VFD configurations are set per the latest literature.

Fault F602 – IDF VFD LOCKOUT

This fault occurs when the indoor fan VFD informs the SystemVu control that it has an active lockout fault. This will cause a unit shutdown, and requires a power cycle to reset the VFD. Refer to the VFD section or literature for details on the specific VFD fault. Verify VFD configurations are set per the latest literature.

Alert A603 – IDF VFD IN HAND

This alert occurs when the indoor fan VFD informs the SystemVu control that it is no longer in auto control and in either hand or off mode. This can only be done with the accessory VFD keypad. This will automatically reset when the VFD is placed back into auto mode for the VFD keypad. Refer to the

VFD section or literature for details on the specific VFD fault. Verify VFD configurations are set per the latest literature.

Fault F604 – IDF VFD IN HAND

This fault occurs when the indoor fan VFD informs the SystemVu control that it is no longer in auto control and in either hand or off mode. This can only be done with the accessory VFD keypad. This will cause a unit shutdown, and will automatically reset when the VFD is placed back into auto mode for the VFD keypad. Refer to the VFD section or literature for details on the specific VFD fault. Verify VFD configurations are set per the latest literature.

Alert A605 – IDF VFD THERMALWARNING

This fault occurs when the indoor fan VFD informs the SystemVu control that it has an active warning. This will cause an IDF speed reduction of 10%, and will automatically reset when the VFD alert is cleared. Refer to the VFD section or literature for details on the specific VFD fault. Verify VFD configurations are set per the latest literature.

Alert A606 – IDF VFD VOLTAGE WARNING

See alert A605.

Alert A607 – IDF VFD CURRENT LIMIT

See alert A605.

Alert A608 – IDF VFD WARNING

See alert A605.

Fault F611 – IDF VFD EARTH FAULT

See fault F601.

Fault F612 – IDF VFD CTLWORD LOSS

See fault F601.

Fault F613 – IDF VFD OVER CURRENT

See fault F601.

Fault F614 – IDF VFD MOTOR OVER TEMP

See fault F601.

Fault F615 – IDF VFD OVERLOAD

See fault F601.

Fault F616 – IDF VFD UNDER VOLTAGE

See fault F601.

Fault F617 – IDF VFD OVER VOLTAGE

See fault F601.

Fault F618 – IDF VFD SHORT CIRCUIT

See fault F601.

Fault F619 – IDF VFD MAIN PHASE LOSS

See fault F601.

Fault F620 – IDF VFD PHASE U LOSS

See fault F601.

Fault F621 – IDF VFD PHASE V LOSS

See fault F601.

Fault F622 – IDF VFD PHASEWLOSS

See fault F601.

Fault F623 – IDF VFD CONTROL VOLTAGE

See fault F601.

Fault F624 – IDF VFD SUPPLY VDD

See fault F601.

Alert A700 – ECON NOT MODULATING

This alert occurs when the economizer feedback is enabled and the actual speed does reach the commanded speed in the economizer travel time configuration value. This alert will automatically reset when the actual position does reach the commanded position. This is usually caused by installation of the wrong actuator, no economizer gear motion, or actuator direction control switch (CCW, CW) wrong. Check damper blades, gears, and actuator. This alert will usually be accompanied by another descriptive informational alert.

Alert A701 – ECON STUCK CLOSED

See alert A700.

Alert A702 – ECON STUCK OPEN

See alert A700.

Alert A703 – IDF MECH DISCONNECTED

This alert occurs when the Alert A700 is not active, yet the control determines that the economizer changes are not aligning with the temperature changes. This will require a manual reset to ensure the economizer is inspected. This is usually caused by the actuator not properly secured to the damper shaft.

Alert A710 – ECON NOT COOLING

See alert A700.

Alert A711 – ECON IMPROPER COOLING

See alert A700.

Alert A712 – EXCESSIVE OUTDOOR AIR

See alert A700.

Table 16 — SystemVu™ Controller Alarm Codes

FAULT OR ALERT	ACTION TAKEN BY CONTROL	RESET METHOD	PROBABLE CAUSE
F010-MBB LOW VOLTAGE	Unit Shutdown	Automatic	Brownout condition, low supply voltage, supply power missing a phase.
F011-MBB REFERENCE VOLTAGE	Unit Shutdown	Automatic	MBB failure or supply voltage low.
A012-MBB ZERO CROSSING	Alert Generated	Automatic	MBB failure or supply voltage frequency too high or too low.
F013-MBB FUSE 2 OPEN	Unit Shutdown	Automatic	A switch input has a wiring error or the switch pulled too much current.
F014-MBB FUSE 3 OPEN	Unit Shutdown	Automatic	A switch input has a wiring error or the switch pulled too much current.
A015-MBB RNET VOLTAGE RANGE	Alert Generated	Automatic	MBB failure or supply voltage low.
A016-MBB 24VDC RANGE	4-20mA inputs will be in error	Automatic	MBB failure or supply voltage low.
A017-MBB 5VDC RANGE	Transducer inputs will be in error	Automatic	MBB failure or supply voltage low.
F018-MBB EEPROM FAILURE	Unit Shutdown	Automatic	Software failure or MBB failure.
A019-MBB CLOCK FAILURE	No time, date, and schedule operation	Automatic	Software failure or MBB failure.
A099-COMM LOSS WITH SIOB ON LEN BUS	Loss of communication with IO from SIOB board	Automatic	Wiring problem between MBB and SIOB
F020-SOFTWARE ERROR	Unit Shutdown	Automatic	Corrupt software or software failure.
A100-SAT SENSOR ERROR	No free cooling, and no SAT limit protection	Automatic	Faulty, shorted, or open thermistor caused by wiring error or loose connection.
A101-FST SENSOR RANGE	Alert Generated	Automatic	Faulty or incorrect thermistor caused by improper ohm reading.
A102-FST OPEN SENSOR	Alert Generated	Automatic	Missing or open thermistor caused by wiring error or loose connection.
A103-FST SHORTED SENSOR	Alert Generated	Automatic	Faulty or shorted thermistor caused by wiring error or loose connection.
A104-OAT SENSOR RANGE	No free cooling, no low ambient operation	Automatic	Faulty or incorrect thermistor caused by improper ohm reading.
A105-OAT OPEN SENSOR	No free cooling, no low ambient operation	Automatic	Missing or open thermistor caused by wiring error or loose connection.
A106-OAT SHORTED SENSOR	No free cooling, no low ambient operation	Automatic	Faulty or shorted thermistor caused by wiring error or loose connection.
A107-RAT SENSOR RANGE	No differential DB crossover	Automatic	Faulty or incorrect thermistor caused by improper ohm reading.
A108-RAT OPEN SENSOR	No differential DB crossover	Automatic	Missing or open thermistor caused by wiring error or loose connection.
A109-RAT SHORTED SENSOR	No differential DB crossover	Automatic	Faulty or shorted thermistor caused by wiring error or loose connection.
A110-SPT SENSOR RANGE	No heating or cooling	Automatic	Faulty or incorrect thermistor caused by improper ohm reading.
A111-SPT OPEN SENSOR	No heating or cooling	Automatic	Missing or open thermistor caused by wiring error or loose connection.
A112-SPT SHORTED SENSOR	No heating or cooling	Automatic	Faulty or shorted thermistor caused by wiring error or loose connection.
A130-CIR.A SSP SENSOR RANGE	Shutdown Circuit A	Automatic	Faulty transducer, faulty 5-v power supply, or loose connection.
A131-CIR.A SSP OPEN SENSOR	Shutdown Circuit A	Automatic	Faulty transducer, faulty 5-v power supply, or loose connection.
A132-CIR.A SSP SHORT SENSOR	Shutdown Circuit A	Automatic	Faulty transducer, faulty 5-v power supply, or loose connection.
A133-CIR.A SDP SENSOR RANGE	Shutdown Circuit A	Automatic	Faulty transducer, faulty 5-v power supply, or loose connection.
A134-CIR.A SDP OPEN SENSOR	Shutdown Circuit A	Automatic	Faulty transducer, faulty 5-v power supply, or loose connection.
A135-CIR.A SDP SHORT SENSOR	Shutdown Circuit A	Automatic	Faulty transducer, faulty 5-v power supply, or loose connection.
A150-OUTDOOR AIRFLOW IN CFM OPEN SENSOR	No OACFM Operations	Automatic	Wiring problem or configuration error.
A151-OUTDOOR AIRFLOW IN CFM SHORTED SENSOR	No OACFM Operations	Automatic	Wiring problem or configuration error.
A160-OARH OPEN SENSOR	No Enthalpy crossover	Automatic	Bad sensor, bad wiring, or incorrectly configured sensor.
A161-OARH SHORTED SENSOR	No Enthalpy crossover	Automatic	Bad sensor, bad wiring, or incorrectly configured sensor.
A162-RARH OPEN SENSOR	No Differential Enthalpy crossover	Automatic	Bad sensor, bad wiring, or incorrectly configured sensor.
A163-RARH SHORTED SENSOR	No Differential Enthalpy crossover	Automatic	Bad sensor, bad wiring, or incorrectly configured sensor.
A164-IAQ OPEN SENSOR	No IAQ Operations	Automatic	Bad sensor, bad wiring, or incorrectly configured sensor.
A165-IAQ SHORTED SENSOR	No IAQ Operations	Automatic	Bad sensor, bad wiring, or incorrectly configured sensor.

Table 16 — SystemVu™ Controller Alarm Codes (cont)

FAULT OR ALERT	ACTION TAKEN BY CONTROL	RESET METHOD	PROBABLE CAUSE
A166-OAQ OPEN SENSOR	No OAQ Operations	Automatic	Bad sensor, bad wiring, or incorrectly configured sensor.
A167-OAQ SHORTED SENSOR	No OAQ Operations	Automatic	Bad sensor, bad wiring, or incorrectly configured sensor.
A168-SPACE RELATIVE HUMIDITY OPEN SENSOR	No dehumidifying	Automatic	Bad sensor, bad wiring, incorrectly configured sensor, loss of communication to SIOB.
A169-SPACE RELATIVE HUMIDITY SHORTED SENSOR	No dehumidifying	Automatic	Bad sensor, bad wiring, incorrectly configured sensor, loss of communication to SIOB.
A170-ECON FEEDBACK RANGE	No economizer diagnostics	Automatic	Wiring problem with actuator or configuration error.
A171-ECON FEEDBACK OPEN	No economizer diagnostics	Automatic	Wiring problem with actuator or configuration error.
A172-ECON FEEDBACK SHORTED	No economizer diagnostics	Automatic	Wiring problem with actuator or configuration error.
A190-TSTAT HEAT/COOL CALLS	Run unit in mode activated first	Automatic	Bad thermostat or thermostat wiring.
A191-TSTAT IMPROPER COOL	Run cooling per number of active inputs	Automatic	Bad thermostat or thermostat wiring.
A192-TSTAT IMPROPER HEAT	Run heating per number of active inputs	Automatic	Bad thermostat or thermostat wiring.
F200-FIRE SHUTDOWN	Unit Shutdown	Automatic	Smoke detected by smoke detector.
F201-CONDENSATE OVERFLOW	Cooling Shutdown	Automatic	Drain pan plugged, sensor error, or configuration error.
A203-DIRTY FILTER	Alert Generated	Automatic	Dirty filter or expired filter timer.
F204-REMOTE SHUTDOWN	Unit Shutdown	Automatic	Remote activation of the shutdown switch.
A210-GENERAL STATUS	Alert Generated	Automatic	General switch activation or wrong configuration.
F211-GENERAL STATUS	Unit Shutdown	Automatic	General switch activation or wrong configuration.
F310-CIR.A DOWN DUE TO FAIL	Shutdown Circuit A	Manual	Compressors have 3 strikes or has been locked out by another alarm.
F311-CIR.A LOW CHARGE	Shutdown Circuit A	Manual	Low refrigerant or faulty pressure transducer.
A312-CIR.A UNEXPECTED OFF	Strike for active compressors	Automatic	Compressor failure, transducer failure, or nuisance operating conditions.
A313-CIR.A HIGH DISCHARGE	Unload compression and up ODF to High cool speed	Automatic	An overcharged system, high outdoor ambient temperature coupled with dirty outdoor coil, plugged filter drier, or ODF speeds being set too low.
A314-CIR.A HPS TRIP	Add compressor strikes	Automatic	An overcharged system, high outdoor ambient temperature coupled with dirty outdoor coil, plugged filter drier, or ODF speeds being set too low.
A315-CIR.A LOW DISCHARGE	Add compressor strikes	Automatic	An undercharged system, low outdoor ambient temperature coupled with dirty outdoor coil, plugged filter drier, or ODF speeds being set too high
A316-CIR.A LOW SUCTION	Add compressor strikes	Automatic	Low refrigerant charge, dirty filters, evaporator fan turning backwards, loose or broken fan belt, plugged filter drier, faulty transducer, excessively cold return air, or stuck open economizer when the ambient temperature is low.
A317-CIR.A PRESSURE RATIO	Add compressor strikes	Automatic	Low refrigerant charge, plugged filter drier, faulty transducer, the ambient temperature is low and the ODFs are running too fast.
F318-COMPRESSOR STUCK ON	Unit in Safety Shutdown	Manual	Welded contactor or frozen compressor relay on MBB.
F319-C.A1 DOWN DUE TO FAIL	Lockout Compressor A1	Manual	Compressor A1 has 3 strikes or has been locked out by another alarm.
A320-C.A1 REVERSE ROTATION	Add Strike for compressor A1	Automatic	Wiring causing reverse rotation or faulty compressor.
A321-C.A1 FAIL TO PRESSURE	Add Strike for compressor A1	Automatic	Wiring causing reverse rotation or faulty compressor.
F322-C.A2 DOWN DUE TO FAIL	Lockout Compressor A2	Manual	Compressor A2 has 3 strikes or has been locked out by another alarm.
A323-C.A2 REVERSE ROTATION	Add Strike for compressor A2	Automatic	Wiring causing reverse rotation or faulty compressor.
A324-C.A2 FAIL TO PRESSURE	Add Strike for compressor A2	Automatic	Wiring causing reverse rotation or faulty compressor.
A410-IGC IGNITION FAILURE	Lockout Heat	Automatic	Faulty wiring of the IGC, no gas flow, or wrong configuration.
F411-ROLLOUT WITHOUT HEAT	Unit in Safety Shutdown	Automatic	Faulty wiring of the IGC, or rollout switch trip without a heat call.
F412-RUN AWAY HEAT	Unit in Safety Shutdown	Automatic	Heat stuck on causing high SAT, or low air flow.
A510-INDOOR FAN STATUS	Alert Generated	Automatic	Belt broke, motor failure, or configuration error.
F511-IDF OFF WHEN COMMAND ON	Unit Shutdown	Manual	Fan stuck on or incorrect configuration.
F512-IDF ONWHEN COMMAND OFF	Unit Shutdown	Manual	Tripped circuit breaker, broken belt, bad indoor fan motor, or incorrect configuration.
F600-IDF VFD COMMUNICATION	Unit Shutdown	Automatic	Communication failure, noise on the bus, wiring error, or configuration error.
F601-IDF VFD UNEXPECTED	Unit Shutdown	Automatic	VFD fault, refer to VFD section.
F602-IDF VFD LOCKOUT	Unit Shutdown	Power Cycle	Cycle VFD locked itself out.
A603-IDF VFD IN HAND	Alert Generated	Automatic	VFD keypad used to put the VFD in hand or off mode.
F604-IDF VFD IN HAND	Unit Shutdown	Automatic	VFD keypad used to put the VFD in hand or off mode.
A605-IDF VFD THERMAL WARNING	IDF speed reduced	Automatic	Motor improper size, motor overload, or configuration errors.

Table 16 — SystemVu™ Controller Alarm Codes (cont)

FAULT OR ALERT	ACTION TAKEN BY CONTROL	RESET METHOD	PROBABLE CAUSE
A606-IDF VFD VOLTAGE WARNING	IDF speed reduced	Automatic	Motor improper size, motor overload, or configuration errors.
A607-IDF VFD CURRENT LIMIT	IDF speed reduced	Automatic	Motor improper size, motor overload, or configuration errors.
A608-IDF VFD WARNING	IDF speed reduced	Automatic	Motor improper size, motor overload, or configuration errors.
F611-IDF VFD EARTH FAULT	Unit Shutdown	Automatic	VFD fault, refer to VFD section
F612-IDF VFD CTL WORD LOSS	Unit Shutdown	Automatic	VFD fault, refer to VFD section
F613-IDF VFD OVER CURRENT	Unit Shutdown	Automatic	VFD fault, refer to VFD section
F614-IDF VFD MOTOR OVER TEMP	Unit Shutdown	Automatic	VFD fault, refer to VFD section
F615-IDF VFD OVERLOAD	Unit Shutdown	Automatic	VFD fault, refer to VFD section
F616-IDF VFD UNDER VOLTAGE	Unit Shutdown	Automatic	VFD fault, refer to VFD section
F617-IDF VFD OVER VOLTAGE	Unit Shutdown	Automatic	VFD fault, refer to VFD section
F618-IDF VFD SHORT CIRCUIT	Unit Shutdown	Automatic	VFD fault, refer to VFD section
F619-IDF VFD MAIN PHASE LOSS	Unit Shutdown	Automatic	VFD fault, refer to VFD section
F620-IDF VFD PHASE U LOSS	Unit Shutdown	Automatic	VFD fault, refer to VFD section
F621-IDF VFD PHASE V LOSS	Unit Shutdown	Automatic	VFD fault, refer to VFD section
F622-IDF VFD PHASE W LOSS	Unit Shutdown	Automatic	VFD fault, refer to VFD section
F623-IDF VFD CONTROL VOLTAGE	Unit Shutdown	Automatic	VFD fault, refer to VFD section
F624-IDF VFD SUPPLY VDD	Unit Shutdown	Automatic	VFD fault, refer to VFD section
A700-ECON NOT MODULATING	Alert Generated	Automatic	No economizer motion. Check damper blades, gears, and actuator. Actuator direction control switch (CCW, CW) wrong.
A701-ECON STUCK CLOSED	Alert Generated	Automatic	No economizer motion. Check damper blades, gears, and actuator. Actuator direction control switch (CCW, CW) wrong.
A702-ECON STUCK OPEN	Alert Generated	Automatic	No economizer motion. Check damper blades, gears, and actuator. Actuator direction control switch (CCW, CW) wrong.
A703-ECON MECH DISCONNECTED	Alert Generated	Manual	No economizer motion. Check damper blades, gears, and actuator. Actuator direction control switch (CCW, CW) wrong.
A710-ECON NOT COOLING	Alert Generated	Automatic	No economizer motion. Check damper blades, gears, and actuator. Actuator direction control switch (CCW, CW) wrong.
A711-ECON IMPROPER COOLING	Alert Generated	Automatic	No economizer motion. Check damper blades, gears, and actuator. Actuator direction control switch (CCW, CW) wrong.
A712-EXCESSIVE OUTDOOR AIR	Alert Generated	Automatic	No economizer motion. Check damper blades, gears, and actuator. Actuator direction control switch (CCW, CW) wrong.

Control Module Communication

RED LED

Proper operation of the MBB control board can be visually checked by looking at the red status LED. When operating correctly, the red status LED should blink at a rate of once every 2 seconds. If the red LED is not blinking, verify that correct power is being supplied. A blinking red LED at the rate of once per second means that software is not loaded on the board. Also, be sure that the board is supplied with the current software. If necessary, reload current software. A board LED that is lit continuously should be replaced.

GREEN LED

The MBB has one green LED. The Local Equipment Network (LEN) LED should always be blinking whenever power is on. If LEN LED is not blinking, check LEN connections for potential communication errors (MBB J15, J16, J17, and on the Display J2). Communication between modules is accomplished by a 3-wire sensor bus. These 3 wires run in parallel from module to module. The MBB J17 and Display J2 connectors provide both power and communication directly at the connector for accessories like the Navigator™ display. The MBB J15 connector provides a LEN interface to the indoor fan VFD.

YELLOW LED

The MBB has one yellow LED which is used to indicate Building Automated System (BAS) communication activity. The LED will blink when the MBB transmits a message on the bus.

Communication Failures

If the Indoor Fan VFD or Navigator display Communication Failure or the green or yellow LED's do not flash on the boards, then the problem could be the communication chip on one of the control boards (MBB). Use an ohm meter to measure the resistance on the communication pins of the boards to determine if the board is bad. If the reading is less than half the value indicated in Table 17, then the board needs to be replaced.

IMPORTANT: The resistive values should be read when the board is powered off, the unit is locked out, and board connectors are disconnected.

Cooling Troubleshooting

Use the SystemVu™ Display or a CCN device to view the cooling status display and the cooling diagnostic display (see Appendices) for information on the cooling operation. Check the current alarms and alarm history for any cooling alarm codes and correct any causes. (See Table 16.) Verify any unique control configurations per installed site requirements or accessories.

If alarms conditions are corrected and cleared, operation of the compressors and fans may be verified by using the Service Test mode. (See Table 4.) See Table 18 for general cooling service analysis.

Table 17 — Communication Resistances

DEVICE	(LEN) RESISTANCE BETWEEN PINS / CONNECTOR			(BAS) RESISTANCE BETWEEN PINS / CONNECTOR			(RNET) RESISTANCE BETWEEN PINS / CONNECTOR		
	Pins 1 to 3	Pins 1 to 2	Pins 2 to 3	Pins 1 to 3	Pins 1 to 2	Pins 2 to 3	Pins GND to +	Pins GND to -	Pins + to -
MBB	19.92 KΩ	10.63 KΩ	9.51 KΩ	19.92 KΩ	10.63 KΩ	9.51 KΩ	2.25 KΩ	1 KΩ	3.3 KΩ

Table 18 — Cooling Service Analysis

PROBLEM	CAUSE	REMEDY
Compressor and Fan Will Not Start	Power failure.	Call power company.
	Fuse blown or circuit breaker tripped.	Replace fuse or reset circuit breaker.
	Disconnect off.	Power disconnect.
	Compressor time guard to prevent short cycling.	Check using SystemVu Display.
	Thermostat or occupancy schedule set point not calling for cooling.	Check using SystemVu Display.
	Outdoor temperature too low.	Check Compressor Lockout Temperature using SystemVu Display.
	Active alarm.	Check active alarms using SystemVu Scrolling Marquee.
Compressor Cycles (other than normally satisfying thermostat)	Insufficient line voltage.	Determine cause and correct.
	Active alarm.	Check active alarms using SystemVu Scrolling Marquee.
Compressor Operates Continuously	Unit undersized for load.	Decrease load or increase size of unit.
	Thermostat or occupancy schedule set point too low.	Reset thermostat or schedule set point.
	Dirty air filters.	Replace filters.
	Low refrigerant charge.	Check pressure, locate leak, repair, evacuate, and recharge.
	Condenser coil dirty or restricted.	Clean coil or remove restriction.
Excessive Condenser Pressures	Dirty condenser coil.	Clean coil.
	Refrigerant overcharge.	Recover excess refrigerant.
	Faulty TXV.	1. Check TXV bulb mounting and secure tightly to suction line and insulate. 2. Replace TXV (and filter drier) if stuck open or closed.
	Condenser air restricted or air short cycling.	Determine cause and correct.
	Restriction in liquid tube.	Remove restriction.
Condenser Fans Not Operating	No power to contactors.	Fuse blown or plug at motor loose.
	High heat load.	Check for sources and eliminate.
Excessive Suction Pressure	Faulty TXV.	1. Check TXV bulb mounting and secure tightly to suction line and insulate. 2. Replace TXV (and filter drier) if stuck open or closed.
	Refrigerant overcharged.	Recover excess refrigerant.
Suction Pressure Too Low	Dirty air filters.	Replace air filters.
	Low refrigerant charge.	Check pressure, locate leak, repair, evacuate, and recharge.
	Faulty TXV.	1. Check TXV bulb mounting and secure tightly to suction line and insulate. 2. Replace TXV (and filter drier) if stuck open or closed.
	Insufficient evaporator airflow.	Check belt tension. Check for other restrictions.
	Temperature too low in conditioned area (low return-air temperature).	Reset thermostat or occupancy schedule.

LEGEND

TXV — Thermostatic Expansion Valve

Humidi-MiZer® System Troubleshooting

Use the SystemVu™ control display or a CCN device to view the cooling status display and the cooling diagnostic display. See “Optional Humidi-MiZer Dehumidification System” on page 21 for information on the cooling operation and the related Humidi-MiZer system operation. Check the current alarms and alarm history for any cooling alarm codes and correct any causes (see Table 16 on page 38). Verify any unique control configurations per installed site requirements or accessories.

If alarm conditions are corrected and cleared, operation of the compressors, fans, and Humidi-MiZer system valves may be verified by using the Service Test mode (see Table 4 on page 13). In addition to general cooling service analysis (Table 18), see Table 19 on page 42 for general Humidi-MiZer system service analysis.

NOTE: Wiring, operation, and charge are different on a Humidi-MiZer system unit compared to a standard unit.

Table 19 — Humidi-MiZer System Service Analysis

PROBLEM	CAUSE	REMEDY
Subcooling Reheat Mode Will Not Activate	General cooling mode problem.	See Cooling Service Analysis (Table 18).
	No dehumidification demand.	See No Dehumidification Demand, below.
	IOB operation.	See IOB Operation, below.
	Circuit LDV valve problem.	See LDV Valve Operation, below.
Hot Gas Reheat Mode Will Not Activate	General cooling mode problem.	See Cooling Service Analysis (Table 18).
	No dehumidification demand.	See No Dehumidification Demand, below.
	IOB operation.	See IOB Operation, below.
	Circuit LDV valve problem.	See LDV (3-Way) Valve Operation, below.
	Circuit RDV valve is not open.	See RDV Valve Operation, below.
No Dehumidification Demand	Outdoor temperature too low.	Check Reheat Circuit Limit Temperatures Unit Configurations → Cooling → Humz Lockout OAT
	Relative humidity setpoint is too low — Humidistat	Check/reduce setting on accessory humidistat.
	Relative humidity setpoint is too low — RH sensor.	Check Space RH Setpoints (Setpoints → SPRH)
	Software configuration error for accessory humidistat.	Check Space Humidity Switch (<i>SETTINGS</i> → <i>UNIT CONFIGURATIONS</i> → <i>SWITCH INPUTS CONFIGS</i> → <i>HUMSTAT CHANNEL</i>)
	Software configuration error for accessory humidity sensor.	Check RH Sensor (<i>SETTINGS</i> → <i>UNIT CONFIGURATIONS</i> → <i>ANALOG INPUTS CONFIGS</i> → <i>SPRH SENSOR CHANNEL</i>)
IOB Operation	No humidity signal.	Check wiring. Check humidistat or humidity sensor.
	Communication loss to Input-Output Board.	Check wiring connections. Alert A099 - COMM LOSS WITH SIOB.
	No power to output terminals.	Check wiring.
LDV (3-Way) Valve Operation	Relay outputs do not change state.	Replace faulty IOB.
	No 24v signal to input terminals.	Check using Service → LIQ DIVERT A TEST
		Check IOB relay output.
		Check wiring.
	Solenoid coil burnout.	Check transformer and circuit breaker or fuses.
		Check continuous over-voltage is less than 10%.
Check under-voltage is less than 15%.		
Stuck valve.	Check for missing coil assembly parts.	
	Check for damaged valve enclosing tube.	
RDV Valve Operation. (NOTE: Normally Closed When De-energized)	Replace valve. Replace filter drier.	
	No 24v signal to input terminals.	Check using Service → RDV A TEST
		Check IOB relay output.
		Check wiring.
	Solenoid coil burnout.	Check transformer and circuit breaker or fuses.
		Check continuous over-voltage is less than 10%.
Check under-voltage is less than 15%.		
Stuck valve.	Check for missing coil assembly parts.	
	Check for damaged valve enclosing tube.	
Low Sensible Capacity in Normal Cool or Subcooling Reheat Modes	Replace valve. Replace filter drier.	
Low Suction Pressure and High Superheat During Normal Cool Mode	RDV valve open or leaking.	See RDV Valve Operation, above.
	General cooling mode problem.	See Cooling Service Analysis (Table 18).
RDV Valve Cycling On/Off	RDV valve open or leaking.	See RDV Valve Operation, above.
	Hot Gas Reheat mode low suction pressure limit.	Normal Operation During Mixed Circuit Subcooling and Hot Gas Reheat Modes at Lower Outdoor Temperatures.

LEGEND

- IOB** — Input-Output Board
- LDV** — Liquid Diverter Valve
- RDV** — Reheat Discharge Valve
- RH** — Relative Humidity

Economizer Troubleshooting

Use the SystemVu™ Display to view the economizer status. Check the current alerts and faults and the alarm history for economizer specific alerts or any relevant faults or alerts and correct those issues. Use test mode to troubleshoot by ramping the economizer up and down with and without the indoor fan and power exhaust fan on. Inspect the mechanical economizer for actuator, gear, or blade damage. Ensure the actuator is mounted with the correct spring return (close damper when no power applied to unit). Ensure there is a 500 ohm resistor across the actuator as the 4 to 20mA output signal must be converted to 2 to 10v.

The Economizer alerts can be summarized as a failure to modulate the damper blades. This can be due to the actuator not being properly connected to the damper, or because the actuator's feedback signal is indicating that damper is not performing as commanded. The mechanical disconnect diagnostic will run when conditions are appropriate to determine proper air temperature changes. This uses the OAT, RAT, and SAT to tell if the damper is mixing the outdoor air with the return air. The other alerts inform where the damper is stuck relative to the commanded position.

See Table 20 for economizer service analysis.

Table 20 — Economizer Service Analysis

PROBLEM	POSSIBLE CAUSE	REMEDY
Damper does not move	Indoor fan is off.	Check for proper thermostat connection.
		Unit is not configured for continuous fan operation and the thermostat is not calling for heating or cooling.
		Unit is in Unoccupied mode and there is no call for heating or cooling.
		Tripped circuit breaker.
		No power to the unit.
	Unit is off via CCN command.	
	Actuator is unplugged at motor or at economizer board.	Check wiring connections.
	Unit is not configured for economizer.	Configure unit for economizer per the instructions.
	Outdoor-air temperature is above economizer high temperature lockout.	Adjust the high temperature lockout setting if it is incorrect, otherwise, economizer is operating correctly.
	Outdoor-air temperature is below economizer low temperature lockout.	Adjust the low temperature lockout setting if it is incorrect, otherwise, economizer is operating correctly.
Communication loss to economizer board.	Check wiring connections.	
Damper is jammed.	Identify the obstruction and safely remove.	
Economizer operation is limited to minimum position	Minimum position is set incorrectly.	Adjust minimum position setting.
	Outdoor-air temperature is above economizer high temperature lockout.	Adjust the high temperature lockout setting if it is incorrect, otherwise, economizer is operating correctly.
	Outdoor-air temperature is below economizer low temperature lockout.	Adjust the low temperature lockout setting if it is incorrect, otherwise, economizer is operating correctly.
	Enthalpy or differential dry bulb are preventing free cooling.	Check enthalpy and return air compared to outside air temperature.
	Outdoor-air thermistor is faulty.	Replace outdoor-air thermistor.
Low suction pressure problem with a compressor.	Economizer is operating correctly, identify compressor problem.	
Economizer position is less than minimum position	IAQ is controlling minimum damper position.	Adjust the IAQ settings if incorrect, otherwise, the economizer is operating correctly.
	Unit is in Unoccupied mode.	Adjust unit occupied schedule if incorrect, otherwise, economizer is operating correctly.
Economizer does not return to minimum position	Unit is operating under free cooling.	Economizer is operating correctly.
Damper does not close on power loss	Damper is jammed or spring return is backwards.	Identify the obstruction and safely remove.
Economizer is not at configured minimum position	Unit is operating under free cooling or a force is applied to the commanded position.	Economizer is operating correctly.

LEGEND

CCN — Carrier Comfort Network®
IAQ — Indoor Air Quality

Heating Troubleshooting

Use the unit SystemVu™ Display or a CCN device to view the heating status display and the heating diagnostic display (see Appendices) for information on the heating operation. Check the current alarms and alarm history for any heating alarm codes and correct any causes. (See Table 16.) Verify any unique control configurations per installed site requirements or accessories. If alarms conditions are corrected and cleared, operation of the heat stages and indoor fan may be verified by using the Service Test mode. (See Table 4.)

GAS HEAT (48LC UNITS)

See Table 21 for general gas heating service analysis. See Fig. 22 for service analysis of the IGC board logic. Check the status LED on the IGC board for any flashing alarm codes and correct any causes. (See Table 22 on page 46.)

ELECTRIC HEAT (50LC UNITS)

See Table 23 on page 47 for electric heating service analysis.

Table 21 — Gas Heat Service Analysis

PROBLEM	CAUSE	REMEDY
Heat will not turn on	Unit is NOT configured for heat.	Check heating configurations using the SystemVu Display
Burners will not ignite	Active alarm.	Check active alarms using SystemVu Display and the IGC flash codes.
	No power to unit.	Check power supply, fuses, wiring, and circuit breakers.
	No power to IGC (Integrated Gas Control).	Check fuses and plugs.
	Heaters off due to time guard to prevent short cycling.	Check using SystemVu Display and the IGC flash codes.
	Thermostat or occupancy schedule set point not calling for Cooling.	Check using SystemVu Display.
	No gas at main burners.	Check gas line for air and purge as necessary. After purging gas line of air, allow gas to dissipate for at least 5 minutes before attempting to re-light unit.
	Water in gas line.	Drain water and install drip.
Inadequate heating	Dirty air filters.	Replace air filters.
	Gas input too low.	Check gas pressure at manifold. Refer to gas valve adjustment.
	Thermostat or occupancy schedule set point only calling for W1.	Allow time for W2 to energize or adjust setpoints.
	Unit undersized for load.	Decrease load or increase of size of unit.
	Restricted airflow.	Remove restriction. Check SAT compared to the SAT heating limits.
	Too much outdoor air.	Check economizer position and configuration. Adjust minimum position using SystemVu Display.
	Limit switch cycles main burners.	Check rotation of blower, thermostat heat anticipator settings, and temperature rise of unit. Adjust as needed.
Poor flame characteristics	Incomplete combustion (lack of combustion air) results in: Aldehyde odors, CO, sooting flame, or floating flame.	Check all screws around flue outlets and burner compartment. Tighten as necessary.
		Cracked heat exchanger. Replace.
		Unit is over-fired, reduce input. Adjust gas line or manifold pressure.
		Check vent for restriction. Clean as necessary.
Burners will not turn off	Check orifice to burner alignment.	
	Unit is in Minimum on-time.	Check using SystemVu Display and the IGC flash codes.
	Unit running in Service Test mode.	Check using SystemVu Display.
	Main gas valve stuck.	Turn off gas supply and unit power. Replace gas valve.

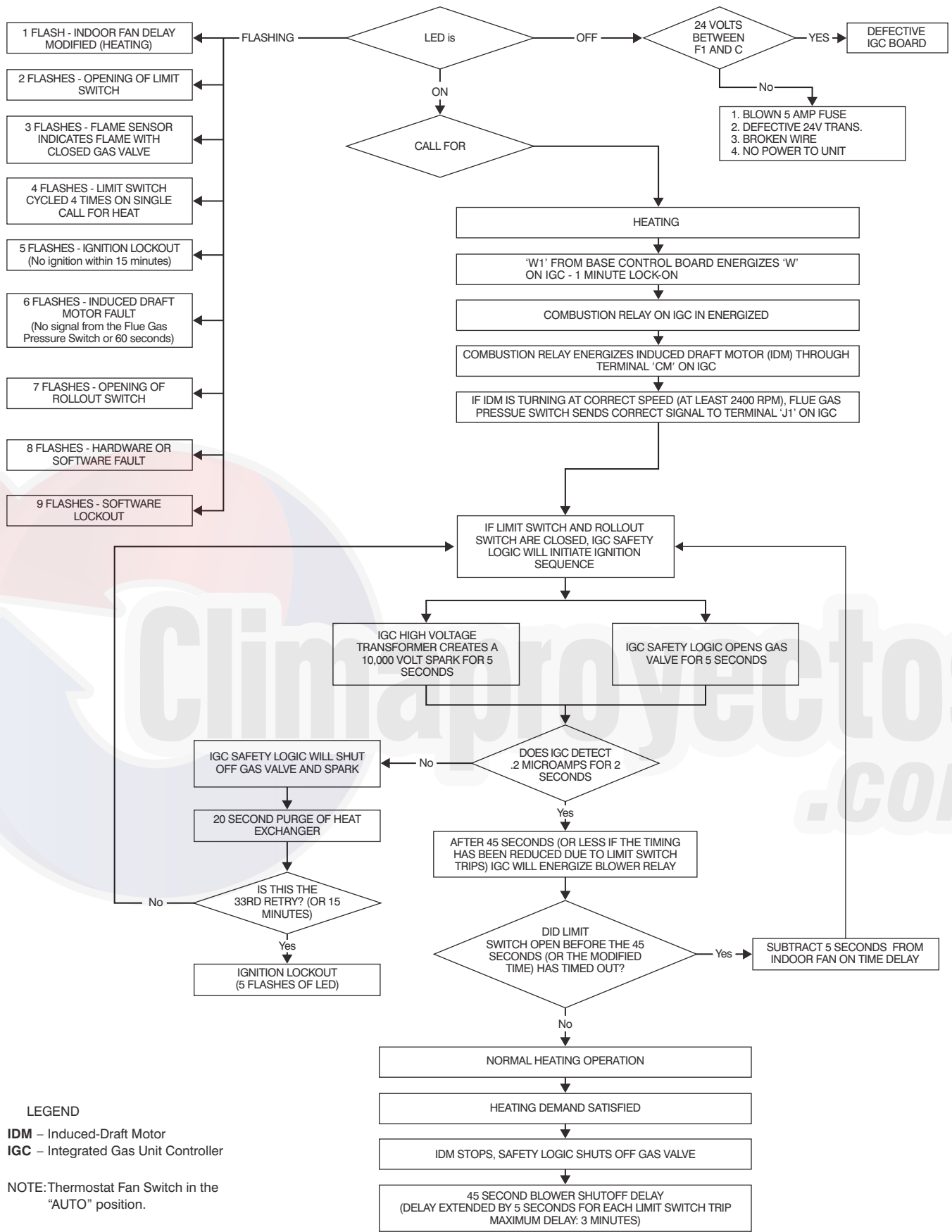

Fig. 22 — IGC Service Analysis Logic

Table 22 — IGC Board LED Alarm Codes

LED FLASH CODE	DESCRIPTION	ACTION TAKEN BY CONTROL	RESET METHOD	PROBABLE CAUSE
On	Normal Operation	—	—	—
Off	Hardware Failure	No gas heating.	—	Loss of power to the IGC. Check 5 amp fuse on IGC, power to unit, 24V circuit breaker, transformer, and wiring to the IGC.
1 flash	Indoor Fan On/Off Delay Modified	5 seconds subtracted from On delay. 5 seconds added to Off delay (3 min max).	Power reset.	High temperature limit switch opens during heat exchanger warm-up period before fan-on delay expires. High temperature limit switch opens within 10 minutes of heat call (W) Off. See Limit Switch Fault.
2 flashes	Limit Switch Fault	Gas valve and igniter Off. Indoor fan and inducer On.	Limit switch closed, or heat call (W) Off.	High temperature limit switch is open. Check the operation of the indoor (evaporator) fan motor. Ensure that the supply-air temperature rise is within the range on the unit nameplate. Check wiring and limit switch operation.
3 flashes	Flame Sense Fault	Indoor fan and inducer On.	Flame sense normal. Power reset for LED reset.	The IGC sensed a flame when the gas valve should be closed. Check wiring, flame sensor, and gas valve operation.
4 flashes	Four Consecutive Limit Switch Fault	No gas heating.	Heat call (W) Off. Power reset for LED reset.	4 consecutive limit switch faults within a single call for heat. See Limit Switch Fault.
5 flashes	Ignition Fault	No gas heating.	Heat call (W) Off. Power reset for LED reset.	Unit unsuccessfully attempted ignition for 15 minutes. Check igniter and flame sensor electrode spacing, gaps, etc. Check flame sense and igniter wiring. Check gas valve operation and gas supply.
6 flashes	Induced Draft Motor Fault	If heat off: no gas heating. If heat on: gas valve Off and inducer On.	Inducer sense normal, or heat call (W) Off.	Inducer sense On when heat call Off, or inducer sense Off when heat call On. Check wiring, voltage, and operation of IGC motor. Check speed sensor wiring to IGC.
7 flashes	Rollout Switch Lockout	Gas valve and igniter Off. Indoor fan and inducer On.	Power reset.	Rollout switch has opened. Check gas valve operation. Check induced-draft blower wheel is properly secured to motor shaft.
8 flashes	Internal Control Lockout	No gas heating.	Power reset.	IGC has sensed internal hardware or software error. If fault is not cleared by resetting 24 v power, replace the IGC.
9 flashes	Temporary Software Lockout	No gas heating.	1 hour auto reset, or power reset.	Electrical interference is disrupting the IGC software.

LEGEND

IGC — Integrated Gas Unit Control
LED — Light-Emitting Diode

NOTES:

1. There is a 3 second pause between alarm code displays.
2. If more than one alarm code exists, all applicable alarm codes will be displayed in numerical sequence.
3. Alarm codes on the IGC will be lost if power to the unit is interrupted.

Table 23 — Electric Heat Service Analysis

PROBLEM	CAUSE	REMEDY
Heat will not turn on	Active alarm.	Check active alarms using SystemVu™ Display.
	Unit is NOT configured for heat.	Check heating configurations using the SystemVu Display.
	No power to unit.	Check power supply, fuses, wiring, and circuit breakers.
	Unit is in minimum heat off-time, or minimum cool-heat changeover time.	Check using SystemVu Display.
	Thermostat or occupancy schedule setpoint not calling for heating.	Check using SystemVu Display.
	Heat forced off in Service Test mode.	Check using SystemVu Display. Turn Service Test mode off.
	No 24 VAC at heater contactor.	Check transformer and circuit breaker.
		Check auto-reset limit switches on heater.
Check manual-reset limit switch (LS) on indoor fan housing.		
Open temperature limit switch on heater.	Check minimum airflow. Check limit switch when it is cool, replace if open.	
Inadequate heating	Dirty air filters.	Replace air filters.
	Thermostat or occupancy schedule setpoint only calling for W1.	Allow time for W2 to energize or adjust setpoints.
	Heat undersized for load.	Decrease load or increase size of heater.
	Restricted airflow.	Remove restriction. Check SAT compared to the SAT heating limits.
	Too much outdoor air.	Check economizer position and configuration. Adjust minimum position.
	Limit switch cycles heaters.	Check rotation of blower and minimum airflow.
	Bad heater elements.	Power off unit and remove high voltage wires. Check resistance of element, replace if open.
Heat will not turn off	Unit is in minimum heat on-time.	Check using SystemVu Display.
	Thermostat or occupancy schedule setpoint still calling for heating.	Check using SystemVu Display.
	Heat forced on in Service Test mode.	Check using SystemVu Display. Turn Service Test mode off.
	Heater contactor failed.	Power off unit. Check contactor and replace if closed.

Phase Protection

The phase loss protection option will monitor the three-phase electrical system to provide phase reversal and phase loss protection.

PHASE REVERSAL PROTECTION

If the control senses an incorrect phase relationship, the relay (K1) will be de-energized (opening its contact). If the phase relationship is correct, the relay will be energized. The control has a self-bypass function after a pre-set time. If the control determines that the three phases stay in a correct relationship for 10 consecutive minutes, the relay will stay energized regardless of the phase sequence of three inputs as long as 24 VAC control voltage is applied. This self-bypass function will be reset if all three phases are restored in a phase loss event.

PHASE LOSS PROTECTION

If the reverse rotation board senses any one of the three phase inputs has no AC voltage, the relay will be de-energized (opening its contact). This protection is always active as long as 24 VAC control voltage is applied, and is not affected by the self bypass function of the phase sequence monitoring function. However, in the event of phase loss, the relay will be re-energized only if all three phases are restored and the three phases are in the correct sequence.

A red LED is provided to indicate the function of the board. See the table below.

LED STATUS	FUNCTION
On continuously	Relay contact closed (normal operation).
Blinking	Relay contact open (phase loss or phase reversal has occurred). No power will be supplied to the control system.
Off	24 VAC control power not present (off).

Thermistor Troubleshooting

The SystemVu™ controller uses thermistors to sense temperatures used to control operation of the unit. Resistances at various temperatures are listed in Table 24. Thermistor pin connection points are shown in the Major System Components section. The general locations of the thermistors are shown in the Major System Components section.

AIR TEMPERATURES

Air temperatures are measured with 10K thermistors. This includes supply-air temperature (SAT), outdoor-air temperature (OAT), space temperature sensors (T55, T56, T59), and return air temperature (RAT).

The outdoor air temperature (OAT) thermistors use a snap-mount to attach through the unit sheet metal panels. The snap-mount tabs must be flattened on the tip end of the sensor to release for removal from the panel. (See Fig. 23.) To reinstall, make sure the snap-mount tabs extend out.

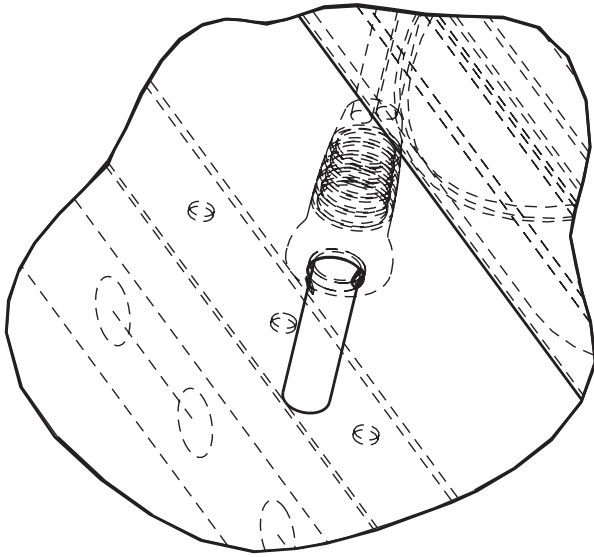

Fig. 23 — OAT Thermistor Mounting

THERMISTOR/TEMPERATURE SENSOR CHECK

A digital volt-ohmmeter is required to perform this check.

Connect the digital volt-ohmmeter across the appropriate thermistor terminals at the J8 connector on the Main Base Board (see Major System Components).

Using the voltage reading obtained, read the sensor temperature from Table 24 on page 49.

To check thermistor accuracy, measure temperature at probe location with an accurate thermocouple-type temperature-measuring instrument. Insulate thermocouple to avoid ambient temperatures from influencing reading. Temperature measured by thermocouple and temperature determined from thermistor voltage reading should be close, within 5°F if care was taken in applying thermocouple and taking readings.

If a more accurate check is required, unit must be shut down and thermistor removed and checked at a known temperature (freezing point or boiling point of water) using either voltage drop measured

across thermistor at the J8 connector, or by determining the resistance with unit shut down and thermistor disconnected from J8. Compare the values determined with the value read by the control in the Temperatures mode using the SystemVu™ display.

Sensor Trim

Corrective offsets can be applied to all the analog inputs. Trim can be used as a form of calibration. The trim works by adding or subtracting the specified amount on the specified analog input. These corrections should only be used when a proper calibrated tool is used to compare to the sensors reading. These corrections are only applied to the local sensor values, a building systems (BAS) communicating values will not account for these corrections. Use the **SERVICE** → **CALIBRATION** menu on the SystemVu Display to adjust these values.

Transducer Troubleshooting

The electronic control uses suction and discharge pressure transducers to measure the pressure of the refrigerant circuits. The pressure/voltage characteristics of these transducers are in shown in Table 25 on page 51 for suction transducers and Table 26 on page 52 for discharge transducers. The 5vdc power is applied to legs A and B of the transducer and legs B to C represent the signal voltage. To use Table 25 on page 51 for troubleshooting, read the voltage across A and B, then subtract the voltage reading from B to C. The voltage drop can be looked up in Table 25 and Table 26 depending on the type of transducer. The accuracy of these transducers can be verified by connecting an accurate pressure gage to the second refrigerant port in the suction and discharge lines.

MAJOR SYSTEM COMPONENTS

General

The 48/50LC single package rooftop units are available with the factory-installed optional SystemVu electronic control system that monitors all operations of the rooftop. The control system is composed of several main control components and available factory-installed options or field-installed accessories as listed in sections below. See Fig. 24-35 for examples of typical control and power schematics for 48/50LC units.

Table 24 — Temperature (°F) vs Resistance/Voltage Drop Values for OAT, RAT, SAT, and SPT Thermistors (10K at 25°C Type II Resistors)

TEMP (°F)	RESISTANCE (OHMS)	VOLTAGE DROP (V)	TEMP (°F)	RESISTANCE (OHMS)	VOLTAGE DROP (V)	TEMP (°F)	RESISTANCE (OHMS)	VOLTAGE DROP (V)
-25	196,453	4.758	35	30,009	3.750	95	6,530	1.975
-24	189,692	4.750	36	29,177	3.723	96	6,383	1.948
-23	183,300	4.741	37	28,373	3.697	97	6,238	1.921
-22	177,000	4.733	38	27,597	3.670	98	6,098	1.894
-21	171,079	4.724	39	26,838	3.654	99	5,961	1.867
-20	165,238	4.715	40	26,113	3.615	100	5,827	1.841
-19	159,717	4.705	41	25,396	3.587	101	5,698	1.815
-18	154,344	4.696	42	24,715	3.559	102	5,571	1.789
-17	149,194	4.686	43	24,042	3.531	103	5,449	1.763
-16	144,250	4.676	44	23,399	3.503	104	5,327	1.738
-15	139,443	4.665	45	22,770	3.474	105	5,210	1.713
-14	134,891	4.655	46	22,161	3.445	106	5,095	1.688
-13	130,402	4.644	47	21,573	3.416	107	4,984	1.663
-12	126,183	4.633	48	20,998	3.387	108	4,876	1.639
-11	122,018	4.621	49	20,447	3.357	109	4,769	1.615
-10	118,076	4.609	50	19,903	3.328	110	4,666	1.591
-9	114,236	4.597	51	19,386	3.298	111	4,564	1.567
-8	110,549	4.585	52	18,874	3.268	112	4,467	1.544
-7	107,006	4.572	53	18,384	3.238	113	4,370	1.521
-6	103,558	4.560	54	17,904	3.208	114	4,277	1.498
-5	100,287	4.546	55	17,441	3.178	115	4,185	1.475
-4	97,060	4.533	56	16,991	3.147	116	4,096	1.453
-3	94,020	4.519	57	16,552	3.117	117	4,008	1.431
-2	91,019	4.505	58	16,131	3.086	118	3,923	1.409
-1	88,171	4.490	59	15,714	3.056	119	3,840	1.387
0	85,396	4.476	60	15,317	3.025	120	3,759	1.366
1	82,729	4.461	61	14,925	2.994	121	3,681	1.345
2	80,162	4.445	62	14,549	2.963	122	3,603	1.324
3	77,662	4.429	63	14,180	2.932	123	3,529	1.304
4	75,286	4.413	64	13,824	2.901	124	3,455	1.284
5	72,940	4.397	65	13,478	2.870	125	3,383	1.264
6	70,727	4.380	66	13,139	2.839	126	3,313	1.244
7	68,542	4.363	67	12,814	2.808	127	3,244	1.225
8	66,465	4.346	68	12,493	2.777	128	3,178	1.206
9	64,439	4.328	69	12,187	2.746	129	3,112	1.187
10	62,491	4.310	70	11,884	2.715	130	3,049	1.168
11	60,612	4.292	71	11,593	2.684	131	2,986	1.150
12	58,781	4.273	72	11,308	2.653	132	2,926	1.132
13	57,039	4.254	73	11,031	2.622	133	2,866	1.114
14	55,319	4.235	74	10,764	2.592	134	2,809	1.096
15	53,693	4.215	75	10,501	2.561	135	2,752	1.079
16	52,086	4.195	76	10,249	2.530	136	2,697	1.062
17	50,557	4.174	77	10,000	2.500	137	2,643	1.045
18	49,065	4.153	78	9,762	2.470	138	2,590	1.028
19	47,627	4.132	79	9,526	2.439	139	2,539	1.012
20	46,240	4.111	80	9,300	2.409	140	2,488	0.996
21	44,888	4.089	81	9,078	2.379	141	2,439	0.980
22	43,598	4.067	82	8,862	2.349	142	2,391	0.965
23	42,324	4.044	83	8,653	2.319	143	2,343	0.949
24	41,118	4.021	84	8,448	2.290	144	2,297	0.934
25	39,926	3.998	85	8,251	2.260	145	2,253	0.919
26	38,790	3.975	86	8,056	2.231	146	2,209	0.905
27	37,681	3.951	87	7,869	2.202	147	2,166	0.890
28	36,610	3.927	88	7,685	2.173	148	2,124	0.876
29	35,577	3.903	89	7,507	2.144	149	2,083	0.862
30	34,569	3.878	90	7,333	2.115	150	2,043	0.848
31	33,606	3.853	91	7,165	2.087	151	2,003	0.835
32	32,654	3.828	92	6,999	2.059	152	1,966	0.821
33	31,752	3.802	93	6,838	2.030	153	1,928	0.808
34	30,860	3.776	94	6,683	2.003	154	1,891	0.795

Table 24 — Temperature (°F) vs Resistance/Voltage Drop Values for OAT, RAT, SAT, and SPT Thermistors (10K at 25°C Type II Resistors) (cont)

TEMP (°F)	RESISTANCE (OHMS)	VOLTAGE DROP (V)	TEMP (°F)	RESISTANCE (OHMS)	VOLTAGE DROP (V)	TEMP (°F)	RESISTANCE (OHMS)	VOLTAGE DROP (V)
155	1,855	0.782	179	1,190	0.532	203	787	0.365
156	1,820	0.770	180	1,169	0.523	204	774	0.359
157	1,786	0.758	181	1,148	0.515	205	762	0.354
158	1,752	0.745	182	1,128	0.507	206	749	0.349
159	1,719	0.733	183	1,108	0.499	207	737	0.343
160	1,687	0.722	184	1,089	0.491	208	725	0.338
161	1,656	0.710	185	1,070	0.483	209	714	0.333
162	1,625	0.699	186	1,052	0.476	210	702	0.328
163	1,594	0.687	187	1,033	0.468	211	691	0.323
164	1,565	0.676	188	1,016	0.461	212	680	0.318
165	1,536	0.666	189	998	0.454	213	670	0.314
166	1,508	0.655	190	981	0.447	214	659	0.309
167	1,480	0.645	191	964	0.440	215	649	0.305
168	1,453	0.634	192	947	0.433	216	639	0.300
169	1,426	0.624	193	931	0.426	217	629	0.296
170	1,400	0.614	194	915	0.419	218	620	0.292
171	1,375	0.604	195	900	0.413	219	610	0.288
172	1,350	0.595	196	885	0.407	220	601	0.284
173	1,326	0.585	197	870	0.400	221	592	0.279
174	1,302	0.576	198	855	0.394	222	583	0.275
175	1,278	0.567	199	841	0.388	223	574	0.272
176	1,255	0.558	200	827	0.382	224	566	0.268
177	1,233	0.549	201	814	0.376	225	557	0.264
178	1,211	0.540	202	800	0.370			

Climaproyectos
.com

Table 25 — Pressure (psig) vs. Voltage Drop Values for Suction Pressure Transducers

PRESSURE (PSIG)	VOLTAGE DROP (V)	PRESSURE (PSIG)	VOLTAGE DROP (V)	PRESSURE (PSIG)	VOLTAGE DROP (V)	PRESSURE (PSIG)	VOLTAGE DROP (V)
0	0.465	68	1.135	136	1.804	204	2.474
2	0.485	70	1.154	138	1.824	206	2.493
4	0.505	72	1.174	140	1.844	208	2.513
6	0.524	74	1.194	142	1.863	210	2.533
8	0.544	76	1.214	144	1.883	212	2.553
10	0.564	78	1.233	146	1.903	214	2.572
12	0.583	80	1.253	148	1.922	216	2.592
14	0.603	82	1.273	150	1.942	218	2.612
16	0.623	84	1.292	152	1.962	220	2.631
18	0.642	86	1.312	154	1.982	222	2.651
20	0.662	88	1.332	156	2.001	224	2.671
22	0.682	90	1.351	158	2.021	226	2.690
24	0.702	92	1.371	160	2.041	228	2.710
26	0.721	94	1.391	162	2.060	230	2.730
28	0.741	96	1.410	164	2.080	232	2.749
30	0.761	98	1.430	166	2.100	234	2.769
32	0.780	100	1.450	168	2.119	236	2.789
34	0.800	102	1.470	170	2.139	238	2.809
36	0.820	104	1.489	172	2.159	240	2.828
38	0.839	106	1.509	174	2.178	242	2.848
40	0.859	108	1.529	176	2.198	244	2.868
42	0.879	110	1.548	178	2.218	246	2.887
44	0.898	112	1.568	180	2.237	248	2.907
46	0.918	114	1.588	182	2.257	250	2.927
48	0.938	116	1.607	184	2.277	252	2.946
50	0.958	118	1.627	186	2.297	254	2.966
52	0.977	120	1.647	188	2.316	256	2.986
54	0.997	122	1.666	190	2.336	258	3.005
56	1.017	124	1.686	192	2.356	260	3.025
58	1.036	126	1.706	194	2.375	262	3.045
60	1.056	128	1.726	196	2.395	264	3.065
62	1.076	130	1.745	198	2.415	266	3.084
64	1.095	132	1.765	200	2.434	268	3.104
66	1.115	134	1.785	202	2.454	270	3.124

Table 26 — Discharge Pressure Transducer (psig) vs. Voltage

PRESSURE (PSIG)	VOLTAGE DROP (V)	PRESSURE (PSIG)	VOLTAGE DROP (V)	PRESSURE (PSIG)	VOLTAGE DROP (V)	PRESSURE (PSIG)	VOLTAGE DROP (V)
14.5	0.500	75	0.871	136	1.245	197	1.619
16	0.509	76	0.877	137	1.251	198	1.625
17	0.515	77	0.883	138	1.257	199	1.631
18	0.521	78	0.889	139	1.263	200	1.637
19	0.528	79	0.895	140	1.269	201	1.643
20	0.534	80	0.902	141	1.275	202	1.649
21	0.540	81	0.908	142	1.282	203	1.656
22	0.546	82	0.914	143	1.288	204	1.662
23	0.552	83	0.920	144	1.294	205	1.668
24	0.558	84	0.926	145	1.300	206	1.674
25	0.564	85	0.932	146	1.306	207	1.680
26	0.570	86	0.938	147	1.312	208	1.686
27	0.577	87	0.944	148	1.318	209	1.692
28	0.583	88	0.951	149	1.325	210	1.698
29	0.589	89	0.957	150	1.331	211	1.705
30	0.595	90	0.963	151	1.337	212	1.711
31	0.601	91	0.969	152	1.343	213	1.717
32	0.607	92	0.975	153	1.349	214	1.723
33	0.613	93	0.981	154	1.355	215	1.729
34	0.620	94	0.987	155	1.361	216	1.735
35	0.626	95	0.993	156	1.367	217	1.741
35	0.626	96	1.000	157	1.374	218	1.747
36	0.632	97	1.006	158	1.380	219	1.754
37	0.638	98	1.012	159	1.386	220	1.760
38	0.644	99	1.018	160	1.392	221	1.766
39	0.650	100	1.024	161	1.398	222	1.772
40	0.656	101	1.030	162	1.404	223	1.778
41	0.662	102	1.036	163	1.410	224	1.784
42	0.669	103	1.043	164	1.416	225	1.790
43	0.675	104	1.049	165	1.423	226	1.797
44	0.681	105	1.055	166	1.429	227	1.803
45	0.687	106	1.061	167	1.435	228	1.809
46	0.693	107	1.067	168	1.441	229	1.815
47	0.699	108	1.073	169	1.447	230	1.821
48	0.705	109	1.079	170	1.453	231	1.827
49	0.711	110	1.085	171	1.459	232	1.833
50	0.718	111	1.092	172	1.466	233	1.839
51	0.724	112	1.098	173	1.472	234	1.846
52	0.730	113	1.104	174	1.478	235	1.852
53	0.736	114	1.110	175	1.484	236	1.858
54	0.742	115	1.116	176	1.490	237	1.864
55	0.748	116	1.122	177	1.496	238	1.870
56	0.754	117	1.128	178	1.502	239	1.876
57	0.761	118	1.134	179	1.508	240	1.882
58	0.767	119	1.141	180	1.515	241	1.888
59	0.773	120	1.147	181	1.521	242	1.895
60	0.779	121	1.153	182	1.527	243	1.901
61	0.785	122	1.159	183	1.533	244	1.907
62	0.791	123	1.165	184	1.539	245	1.913
63	0.797	124	1.171	185	1.545	246	1.919
64	0.803	125	1.177	186	1.551	247	1.925
65	0.810	126	1.184	187	1.557	248	1.931
66	0.816	127	1.190	188	1.564	249	1.938
67	0.822	128	1.196	189	1.570	250	1.944
68	0.828	129	1.202	190	1.576	251	1.950
69	0.834	130	1.208	191	1.582	252	1.956
70	0.840	131	1.214	192	1.588	253	1.962
71	0.846	132	1.220	193	1.594	254	1.968
72	0.852	133	1.226	194	1.600	255	1.974
73	0.859	134	1.233	195	1.606	256	1.980
74	0.865	135	1.239	196	1.613	257	1.987

Table 26 — Discharge Pressure Transducer (psig) vs. Voltage (cont)

PRESSURE (PSIG)	VOLTAGE DROP (V)	PRESSURE (PSIG)	VOLTAGE DROP (V)	PRESSURE (PSIG)	VOLTAGE DROP (V)	PRESSURE (PSIG)	VOLTAGE DROP (V)
258	1.993	320	2.373	382	2.753	444	3.133
259	1.999	321	2.379	383	2.759	445	3.139
260	2.005	322	2.385	384	2.765	446	3.145
261	2.011	323	2.391	385	2.771	447	3.151
262	2.017	324	2.397	386	2.777	448	3.157
263	2.023	325	2.403	387	2.784	449	3.164
264	2.029	326	2.410	388	2.790	450	3.170
265	2.036	327	2.416	389	2.796	451	3.176
266	2.042	328	2.422	390	2.802	452	3.182
267	2.048	329	2.428	391	2.808	453	3.188
268	2.054	330	2.434	392	2.814	454	3.194
269	2.060	331	2.440	393	2.820	455	3.200
270	2.066	332	2.446	394	2.826	456	3.206
271	2.072	333	2.452	395	2.833	457	3.213
272	2.079	334	2.459	396	2.839	458	3.219
273	2.085	335	2.465	397	2.845	459	3.225
274	2.091	336	2.471	398	2.851	460	3.231
275	2.097	337	2.477	399	2.857	461	3.237
276	2.103	338	2.483	400	2.863	462	3.243
277	2.109	339	2.489	401	2.869	463	3.249
278	2.115	340	2.495	402	2.875	464	3.256
279	2.121	341	2.502	403	2.882	465	3.262
280	2.128	342	2.508	404	2.888	466	3.268
281	2.134	343	2.514	405	2.894	467	3.274
282	2.140	344	2.520	406	2.900	468	3.280
283	2.146	345	2.526	407	2.906	469	3.286
284	2.152	346	2.532	408	2.912	470	3.292
285	2.158	347	2.538	409	2.918	471	3.298
286	2.164	348	2.544	410	2.925	472	3.305
287	2.170	349	2.551	411	2.931	473	3.311
288	2.177	350	2.557	412	2.937	474	3.317
289	2.183	351	2.563	413	2.943	475	3.323
290	2.189	352	2.569	414	2.949	476	3.329
291	2.195	353	2.575	415	2.955	477	3.335
292	2.201	354	2.581	416	2.961	478	3.341
293	2.207	355	2.587	417	2.967	479	3.347
294	2.213	356	2.593	418	2.974	480	3.354
295	2.220	357	2.600	419	2.980	481	3.360
296	2.226	358	2.606	420	2.986	482	3.366
297	2.232	359	2.612	421	2.992	483	3.372
298	2.238	360	2.618	422	2.998	484	3.378
299	2.244	361	2.624	423	3.004	485	3.384
300	2.250	362	2.630	424	3.010	486	3.390
301	2.256	363	2.636	425	3.016	487	3.397
302	2.262	364	2.643	426	3.023	488	3.403
303	2.269	365	2.649	427	3.029	489	3.409
304	2.275	366	2.655	428	3.035	490	3.415
305	2.281	367	2.661	429	3.041	491	3.421
306	2.287	368	2.667	430	3.047	492	3.427
307	2.293	369	2.673	431	3.053	493	3.433
308	2.299	370	2.679	432	3.059	494	3.439
309	2.305	371	2.685	433	3.066	495	3.446
310	2.311	372	2.692	434	3.072	496	3.452
311	2.318	373	2.698	435	3.078	497	3.458
312	2.324	374	2.704	436	3.084	498	3.464
313	2.330	375	2.710	437	3.090	499	3.470
314	2.336	376	2.716	438	3.096	500	3.476
315	2.342	377	2.722	439	3.102	501	3.482
316	2.348	378	2.728	440	3.108	502	3.488
317	2.354	379	2.734	441	3.115	503	3.495
318	2.361	380	2.741	442	3.121	504	3.501
319	2.367	381	2.747	443	3.127	505	3.507

Table 26 — Discharge Pressure Transducer (psig) vs. Voltage (cont)

PRESSURE (PSIG)	VOLTAGE DROP (V)	PRESSURE (PSIG)	VOLTAGE DROP (V)	PRESSURE (PSIG)	VOLTAGE DROP (V)	PRESSURE (PSIG)	VOLTAGE DROP (V)
506	3.513	547	3.764	588	4.016	629	4.267
507	3.519	548	3.770	589	4.022	630	4.273
508	3.525	549	3.777	590	4.028	631	4.279
509	3.531	550	3.783	591	4.034	632	4.285
510	3.538	551	3.789	592	4.040	633	4.292
511	3.544	552	3.795	593	4.046	634	4.298
512	3.550	553	3.801	594	4.052	635	4.304
513	3.556	554	3.807	595	4.059	636	4.310
514	3.562	555	3.813	596	4.065	637	4.316
515	3.568	556	3.820	597	4.071	638	4.322
516	3.574	557	3.826	598	4.077	639	4.328
517	3.580	558	3.832	599	4.083	640	4.334
518	3.587	559	3.838	600	4.089	641	4.341
519	3.593	560	3.844	601	4.095	642	4.347
520	3.599	561	3.850	602	4.102	643	4.353
521	3.605	562	3.856	603	4.108	644	4.359
522	3.611	563	3.862	604	4.114	645	4.365
523	3.617	564	3.869	605	4.120	646	4.371
524	3.623	565	3.875	606	4.126	647	4.377
525	3.629	566	3.881	607	4.132	648	4.384
526	3.636	567	3.887	608	4.138	649	4.390
527	3.642	568	3.893	609	4.144	650	4.396
528	3.648	569	3.899	610	4.151	651	4.402
529	3.654	570	3.905	611	4.157	652	4.408
530	3.660	571	3.911	612	4.163	653	4.414
531	3.666	572	3.918	613	4.169	654	4.420
532	3.672	573	3.924	614	4.175	655	4.426
533	3.679	574	3.930	615	4.181	656	4.433
534	3.685	575	3.936	616	4.187	657	4.439
535	3.691	576	3.942	617	4.193	658	4.445
536	3.697	577	3.948	618	4.200	659	4.451
537	3.703	578	3.954	619	4.206	660	4.457
538	3.709	579	3.961	620	4.212	661	4.463
539	3.715	580	3.967	621	4.218	662	4.469
540	3.721	581	3.973	622	4.224	663	4.475
541	3.728	582	3.979	623	4.230	664	4.482
542	3.734	583	3.985	624	4.236	665	4.488
543	3.740	584	3.991	625	4.243	666	4.494
544	3.746	585	3.997	626	4.249	667	4.500
545	3.752	586	4.003	627	4.255		
546	3.758	587	4.010	628	4.261		

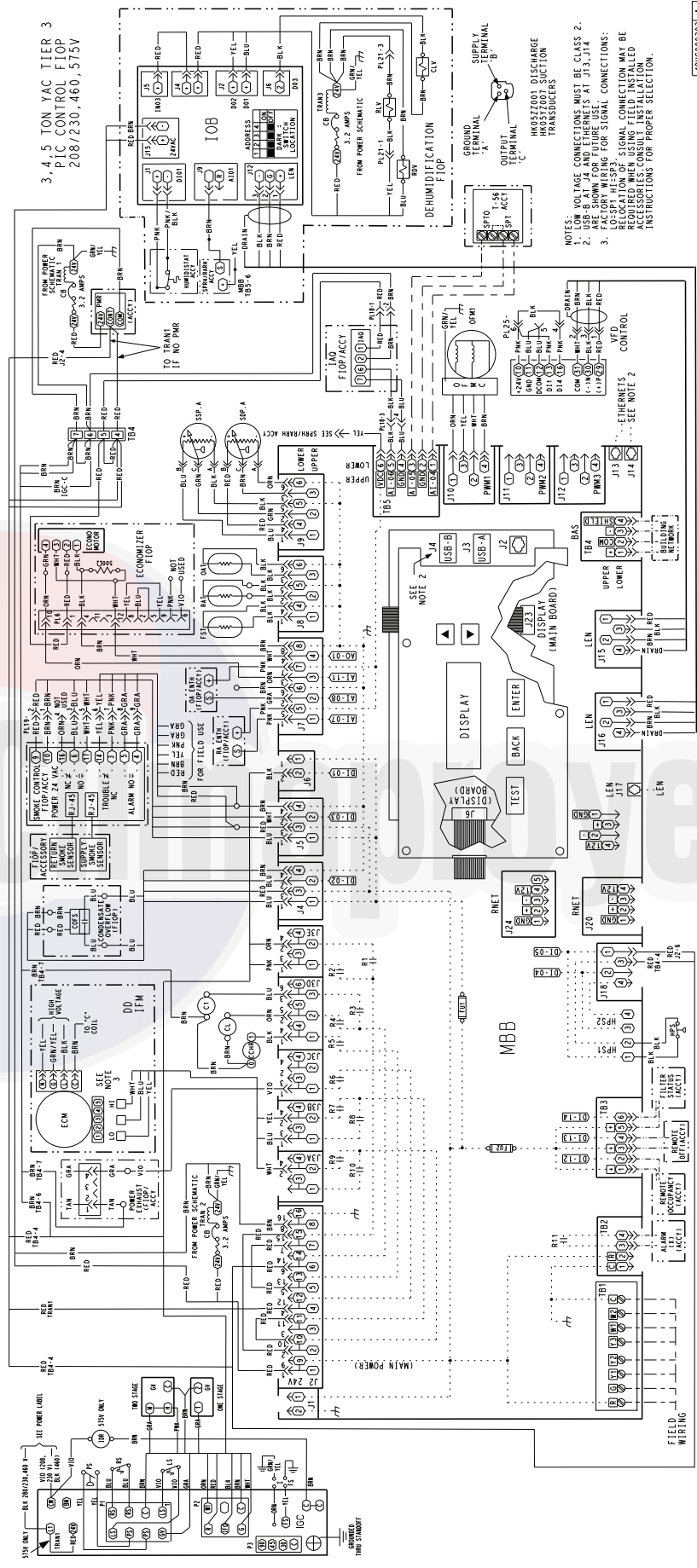

3.4, 5 TON YAC TIER 3
PIC CONTROL FLOP
208/230, 460, 575V

- NOTES:
1. WIRING CONNECTIONS MUST BE CLASS 2.
 2. USE B, BLK, AND ETHNETS AT J1, J14, J15, J16, J17, J18, J19, J20, J21, J22, J23, J24, J25, J26, J27, J28, J29, J30, J31, J32, J33, J34, J35, J36, J37, J38, J39, J40, J41, J42, J43, J44, J45, J46, J47, J48, J49, J50, J51, J52, J53, J54, J55, J56, J57, J58, J59, J60, J61, J62, J63, J64, J65, J66, J67, J68, J69, J70, J71, J72, J73, J74, J75, J76, J77, J78, J79, J80, J81, J82, J83, J84, J85, J86, J87, J88, J89, J90, J91, J92, J93, J94, J95, J96, J97, J98, J99, J100.
 3. ARE SHOWN FOR FUTURE USE.
- RELOCATION OF SIGNAL CONNECTION MAY BE REQUIRED FOR SIGNAL CONNECTIONS. ACCESSORIES CONSULT INSTALLATION INSTRUCTIONS FOR PROPER SELECTION.

48LC030303 A

Fig. 25 — Typical 48LC 04-06 SystemVu™ Control Schematic (208/230v, 460v, 575v)

7.5-10 TON VAC TIER 3
PIC CONTROL FIOP
208/230, 460, 575V

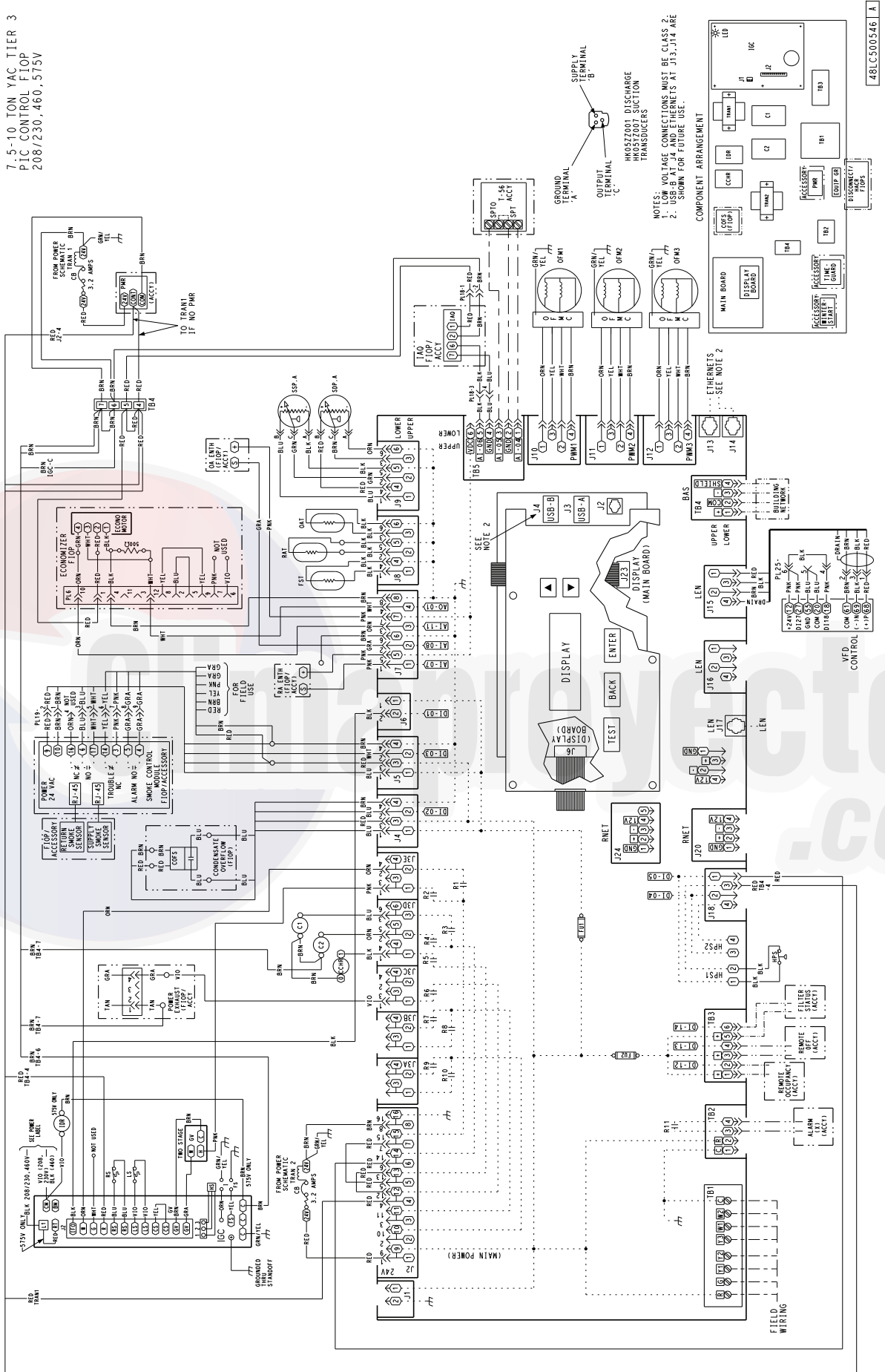

Fig. 26 — Typical 48LC 08-12 SystemVu™ Control Schematic (208/230v, 460v, 575v)

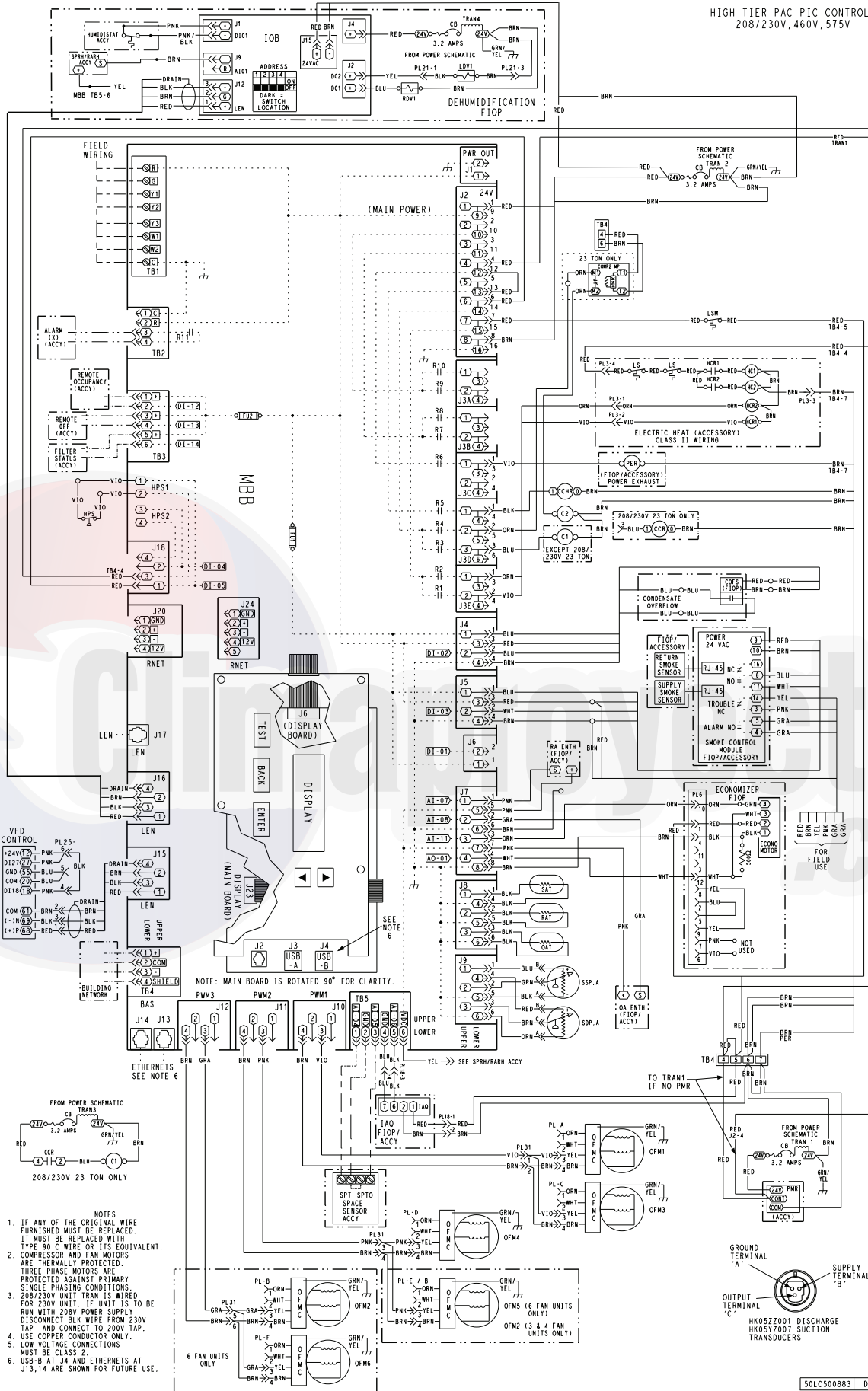
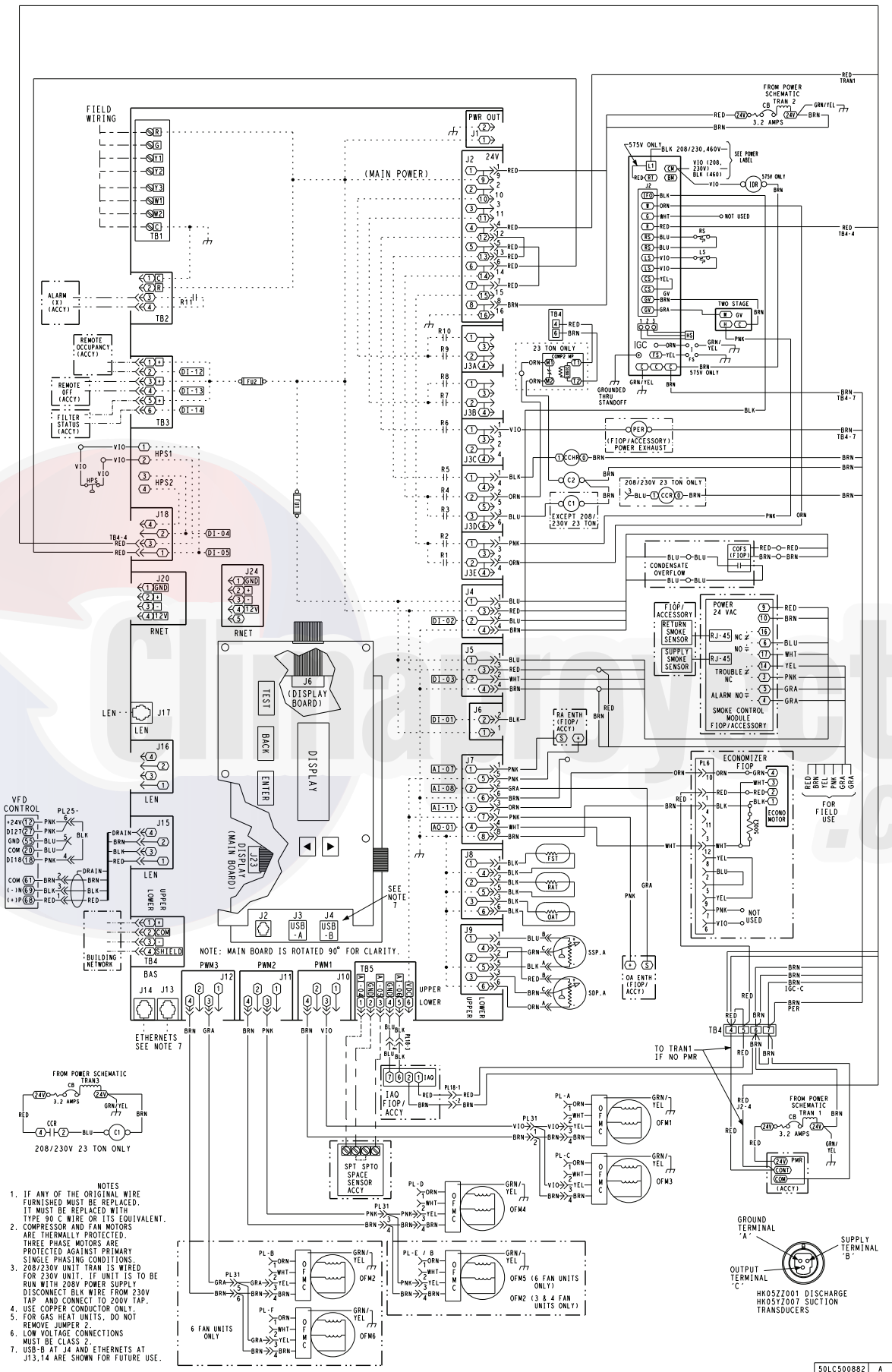

Fig. 28 — Typical 50LC 14-26 SystemVu™ Control Schematic (208/230v, 460v, 575v)



- NOTES
1. IF ANY OF THE ORIGINAL WIRE FURNISHED MUST BE REPLACED. IT MUST BE REPLACED WITH TYPE 90 C WIRE OR ITS EQUIVALENT.
 2. COMPRESSOR AND FAN MOTORS ARE THERMALLY PROTECTED. THREE PHASE MOTORS ARE PROTECTED AGAINST PRIMARY SINGLE PHASING CONDITIONS.
 3. 208/230V UNIT TRN1 IS WIRED FOR 230V UNIT. IF UNIT IS TO BE RUN WITH 208V POWER SUPPLY DISCONNECT BLK WIRE FROM 230V TAP AND CONNECT TO 208V TAP.
 4. USE COPPER CONDUCTOR ONLY.
 5. FOR GAS HEAT UNITS, DO NOT REMOVE JUMPER 2.
 6. LOW VOLTAGE CONNECTIONS MUST BE CLASS 2.
 7. USB-A AT J4 AND ETHERNETS AT J13, J14 ARE SHOWN FOR FUTURE USE.

Fig. 29 — Typical 48LC 14-26 SystemVu™ Control Schematic (208/230v, 460v, 575v)

50LC500862 A

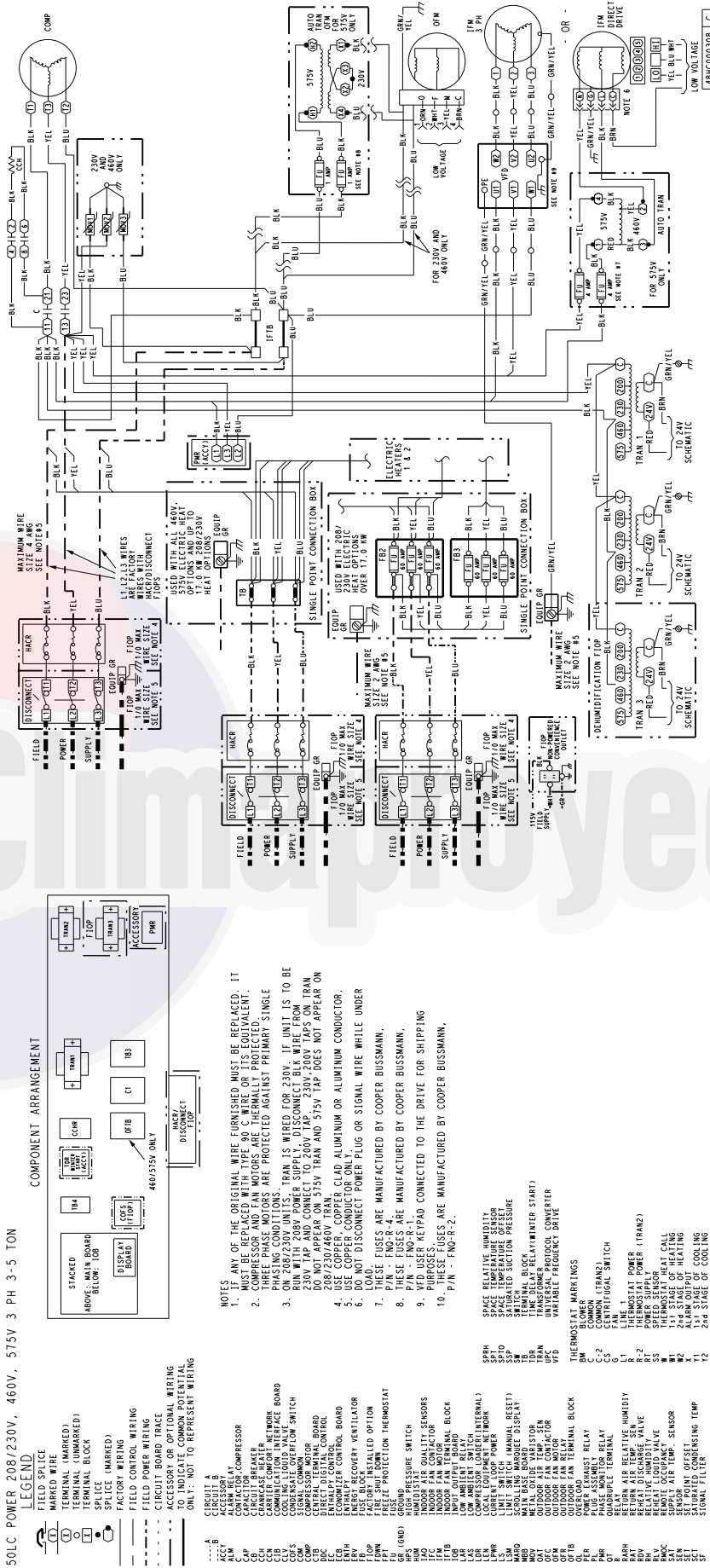

50LC POWER 208/230V, 460V, 575V 3 PH 3-5 TON

LEGEND
 FIELD SPICE
 MARKED WIRE
 TERMINAL (MARKED)
 TERMINAL (UNMARKED)
 TERMINAL BLOCK
 SPICE (MARKED)
 SPICE (UNMARKED)
 FACTORY CONTROL WIRING
 FIELD CONTROL WIRING
 FIELD POWER WIRING
 CIRCUIT BOARD SPACE
 CIRCUIT BOARD COMMON POTENTIAL WIRING
 ONLY: NOT TO REPRESENT WIRING

CIRCUIT A
 A/B
 A/C
 A/D
 A/E
 A/F
 A/G
 A/H
 A/I
 A/J
 A/K
 A/L
 A/M
 A/N
 A/O
 A/P
 A/Q
 A/R
 A/S
 A/T
 A/U
 A/V
 A/W
 A/X
 A/Y
 A/Z

NOTES
 1. IF ANY OF THE ORIGINAL WIRE FURNISHED MUST BE REPLACED, IT MUST BE REPLACED WITH TYPE 90 C WIRE OR ITS EQUIVALENT.
 2. COMPRESSOR AND FAN MOTORS ARE THERMALLY PROTECTED. PHASING CONDITIONS ARE PROTECTED AGAINST PRIMARY SINGLE RUN WITH 208V POWER SUPPLY. TRAIN IS WIRED FOR 230V. IF UNIT IS TO BE RUN WITH 208V POWER SUPPLY, DISCONNECT BLK WIRE FROM TRAIN DO NOT APPEAR ON 575V TRAIN AND 575V TAP DOES NOT APPEAR ON 208/230/460V TRAIN.
 3. USE COPPER, COPPER CLAD ALUMINUM OR ALUMINUM CONDUCTOR.
 4. DO NOT DISCONNECT POWER PLUG OR SIGNAL WIRE WHILE UNDER LOAD.
 5. THESE FUSES ARE MANUFACTURED BY COOPER BUSSMANN.
 6. P/N - FNO-R-1.
 7. THESE FUSES ARE MANUFACTURED BY COOPER BUSSMANN.
 8. P/N - FNO-R-2.

TERMINAL MARKINGS
 SPACE RELATIVE HUMIDITY
 SPACE TEMPERATURE SENSOR
 SATURATED VAPOR PRESSURE
 SWITCH
 TIME DELAY BLOCK
 TIME DELAY RELAY (WINTER START)
 UNIVERSAL PROTOCOL CONVERTER
 VARIABLE FREQUENCY DRIVE
 THERMOSTAT MARKINGS
 C-1 COMMON
 C-2 COMMON (TRAIN2)
 G-1 FAN
 G-2 FAN
 R-1 THERMOSTAT POWER (TRAIN1)
 R-2 THERMOSTAT POWER (TRAIN2)
 S-1 REHEAT DISCHARGE VALVE
 S-2 REHEAT DISCHARGE VALVE
 S-3 SPEED SENSOR
 S-4 SUPPLY AIR TEMP. SENSOR
 S-5 1st STAGE OF HEATING
 S-6 2nd STAGE OF HEATING
 S-7 1st STAGE OF COOLING
 S-8 2nd STAGE OF COOLING
 S-9 SIGNAL FILTER

Fig. 30 — Typical 50LC 04-06 SystemVu™ Power Schematic (208/230v, 460v, 575v)

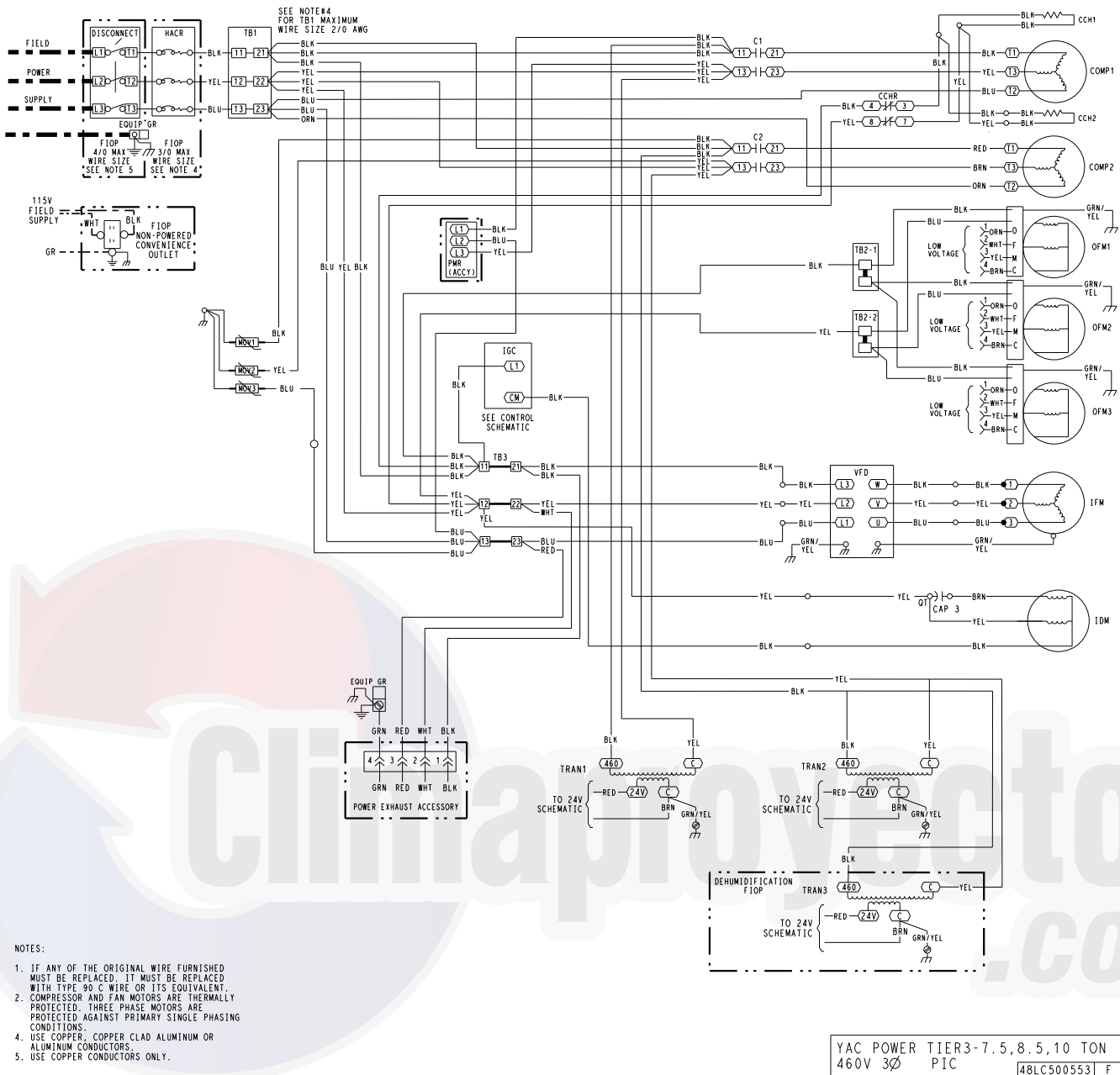

NOTES:

1. IF ANY OF THE ORIGINAL WIRE FURNISHED MUST BE REPLACED, IT MUST BE REPLACED WITH TYPE 90 C WIRE OR ITS EQUIVALENT.
2. COMPRESSOR AND FAN MOTORS ARE THERMALLY PROTECTED. THREE PHASE MOTORS ARE PROTECTED AGAINST PRIMARY SINGLE PHASING CONDITIONS.
4. USE COPPER, COPPER CLAD ALUMINUM OR ALUMINUM CONDUCTORS.
5. USE COPPER CONDUCTORS ONLY.

Fig. 33 — Typical 48LC 08-12 SystemVu™ Power Schematic (460v)

12.5 - 23 TON YAC, PAC POWER
460,575V 3 PH

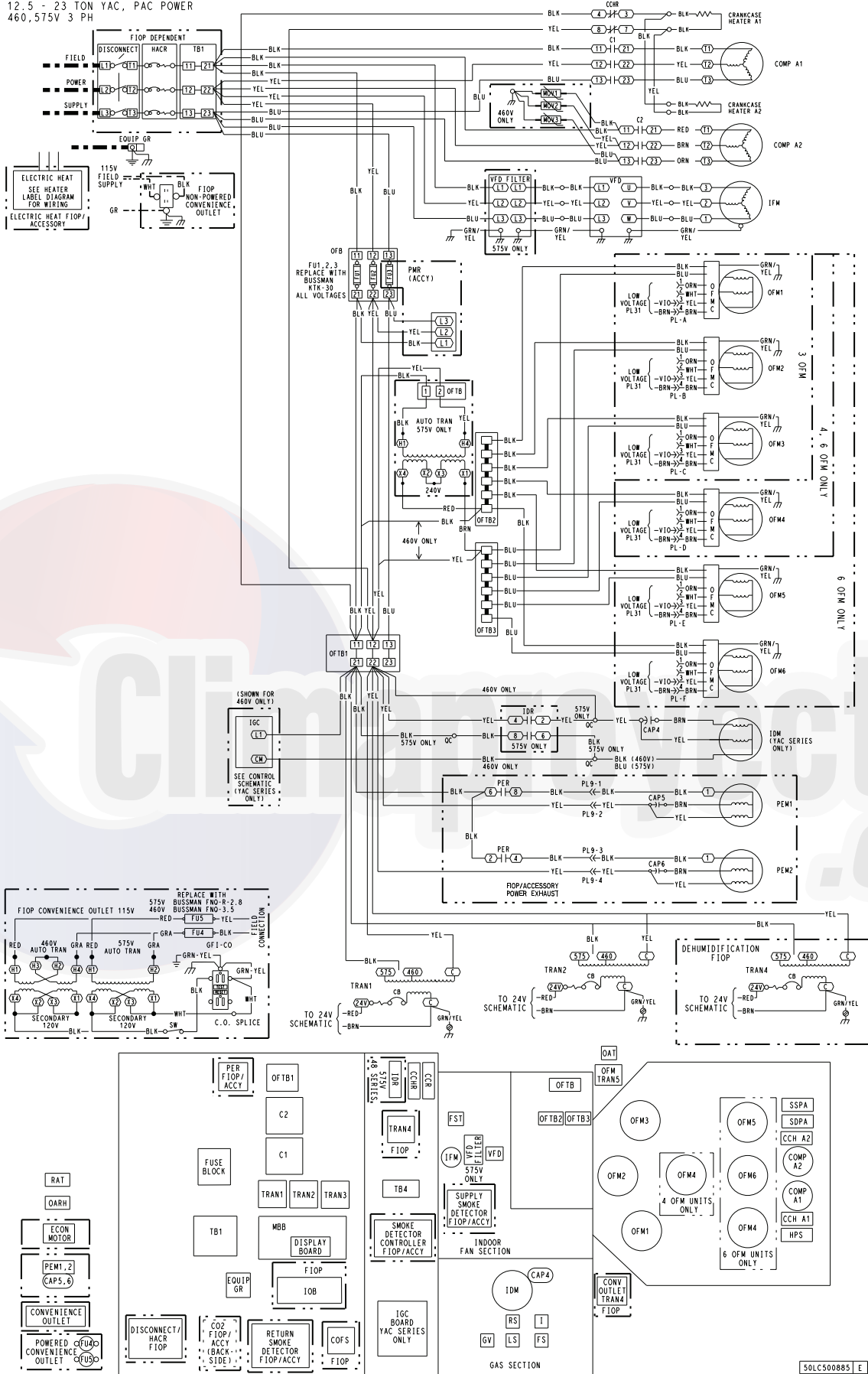

Fig. 35 — 48/50LC 14-26 SystemVu™ Power Schematic

Main Base Board (MBB)

See Fig. 36 and Table 27. The majority of the I/O is connected to the MBB which executes the controls operation of the unit from the software that is loaded onto it.

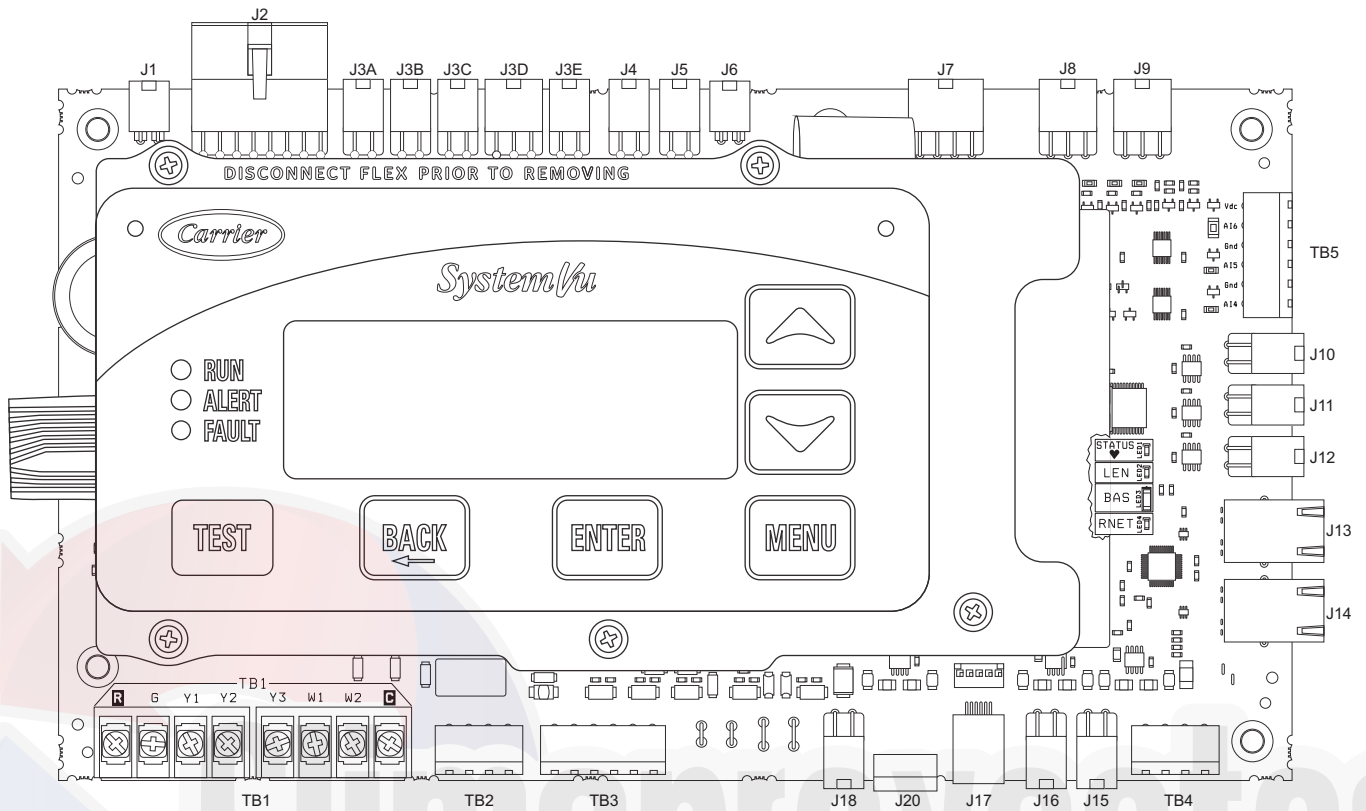

Fig. 36 — Main Base Board (MBB)

Table 27 — Main Base Board (MBB) Connections

DISPLAY NAME	SENSOR LOCATION	I/O TYPE	POINT NAME	CONNECTION PIN NUMBER
Inputs				
Input power from TRAN2	Control Box	24 VAC		J2, 1 and 8
COFS	Drain Pan	24 VAC	COFS	J4, 1-4
FIRE SHUTDOWN	Supply/Return/Space	Switch input	FIREDOWN	J5, 1-4
IGC FAN REQUEST	Gas section	Switch input	IGC_IFO	J6, 1-2
RARH LEVEL	Return/Space	0-20 mA	RARH	J7, 1, 5-6
OARH LEVEL	Economizer	0-20 mA	OARH	J7, 2, 6-7
ECON ACT POSITION	Economizer	2-10vdc	DAMPPOS	J7, 3, 8
FAN SUPPLY TEMP	Indoor fan housing	10k thermistor	FST	J8, 1, 4
RETURN AIR TEMP	Return	10k thermistor	RAT	J8, 2, 5
OUTDOOR AIR TEMP	Outdoor coil	10k thermistor	OAT	J8, 3, 6
CIR.A SUC. PRESS	Circuit A Suction pipe	0-5 VDC pressure transducer	SSP_A	J9, 1-2, 5
CIR.A DIS. PRESS	Circuit A Discharge pipe	0-5 VDC pressure transducer	SDP_A	J9, 4-3, 6
IAQ LEVEL	Return/Space	0-20 mA	IAQ	TB5, 4-6
SLIDER OFFSET VAL	Space	10k thermistor	SPTO	TB5, 2-3
SPACE TEMPERATURE	Space	10k thermistor	SPACE_T	TB5, 1-2
CIR.A HPS	Circuit A Discharge pipe	Switch Input	CIRA_HPS	QC, 1-2J18, 1, 3
Configurable	Field-installed	Switch Input		QC, 3-4J18, 2, 4
REMOTE OCC SWITCH	Field-installed	Switch Input	REMOCC	TB3, 1-2
REMOTE SHUTDOWN	Field-installed	Switch Input	REMSHUT	TB3, 3-4
FILTER STATUS SW	Indoor fan section	Switch Input	FILTSTAT	TB3, 5-6
TSTAT G INPUT	Space	Switch Input	G	TB1, G
TSTAT Y1 INPUT	Space	Switch Input	Y1	TB1, Y1
TSTAT Y2 INPUT	Space	Switch Input	Y2	TB1, Y2
TSTAT Y3 INPUT	Space	Switch Input	Y3	TB1, Y3
TSTAT W1 INPUT	Space	Switch Input	W1	TB1, W1
TSTAT W2 INPUT	Space	Switch Input	W2	TB1, W2
Outputs				
Optional power out	Not used	24 VAC		J1, 1-2
ECON CMD POSITION		0-20 mA	DAMPAMD	J7, 4, 8
ODF SPEED OUT 1		PWM1	ODF1SPD	J10, 1-4
ODF SPEED OUT 2		PWM2	ODF2SPD	J11, 1-4
ODF SPEED OUT 3		PWM3	ODF3SPD	J12, 1-4
ALARM RELAY		Relay	ALMOUT	TB2, 3-4
Not used	Not used	Relay		J3A, 1, 3
Not used	Not used	Relay		J3A, 2, 4
Not used	Not used	Relay		J3B, 1, 3
Not used	Not used	Relay		J3B, 2, 4
PE1 RELAY		Relay	PE1	J3C, 1-4
CCH RELAY		Relay	CCHR1	J3D, 1, 4
COMPRESSOR A2		Relay	COMP_A2	J3D, 2, 5
COMPRESSOR A1		Relay	COMP_A1	J3D, 3, 6
HEAT 2 RELAY		Relay	HEAT_2	J3E, 1, 3
HEAT 1 RELAY		Relay	HEAT_1	J3E, 2, 4
Communication				
Building Automated System (BAS)	Building	Communication		TB4, 1-5
Ethernet	Not used	Communication		J13, J14
IDF SPEED OUTPUT	Indoor fan section	Communication	FANSPEED	J15, 1-4
Expansion LEN Bus	Not used	Communication		J16, 1-4
Local Equipment Network (LEN)		Communication		J17
RNET Sensors	Building	Communication		J20, 1-4
Display Copper Cable		Communication		J23
RNET Service Access		Communication		J24, 1-5
Display Connections				
Display Copper Cable		Communication		J1
Local Equipment Network (LEN)		Communication		J2
USB-A		Communication		J3
USB-B	Not used	Communication		J4
Keypad Ribbon Cable		Communication		J6

Input-Output Board (IOB)

See Fig. 37 and Table 28.

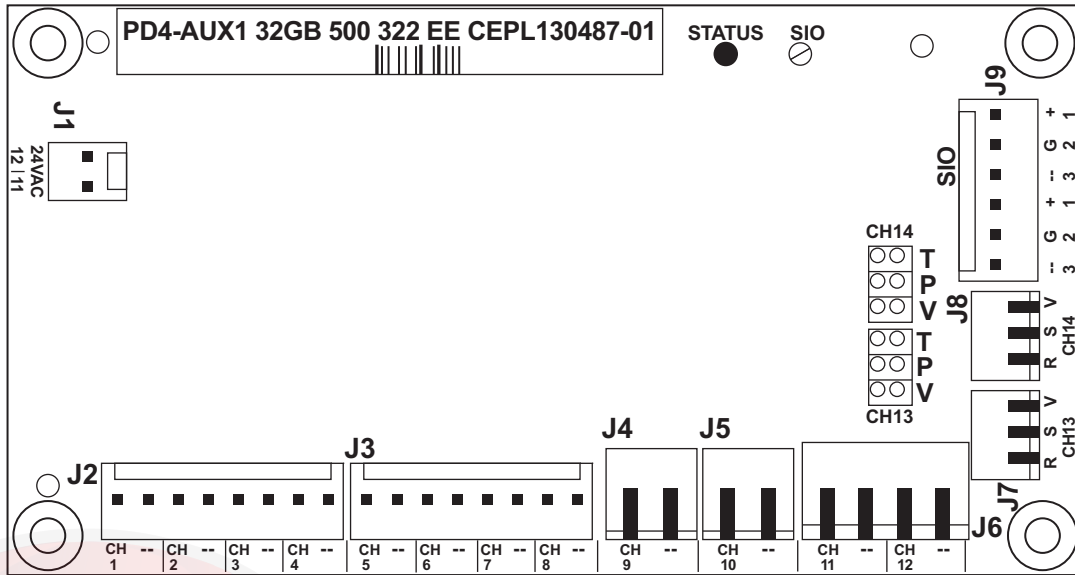

Fig. 37 — Input-Output Board (IOB)

Table 28 — Input-Output Board (IOB) Connections

DISPLAY NAME	POINT DESCRIPTION	SENSOR LOCATION	TYPE OF I/O	CONNECTION PIN NUMBER
Inputs				
HUM	HUMIDISTAT	Field-installed	Switch Input	J1.1
SPRH	SPACE RELATIVE HUMIDITY	Field-installed	0-20 mA	J9.2
Outputs				
RDV	REHEAT DISCHARGE VALVE		24 VAC	J2, 1
LDV	LIQUID DISCHARGE VALVE		24 VAC	J2, 2
Communication				
LEN	LOCAL EQUIPMENT NETWORK (LEN)		Communication	J12

Integrated Gas Control (IGC) Board

The IGC is provided on gas heat units. The IGC controls the direct spark ignition system and monitors the rollout switch, limit switch, and flue gas pressure switch. See Fig. 38 and Table 29.

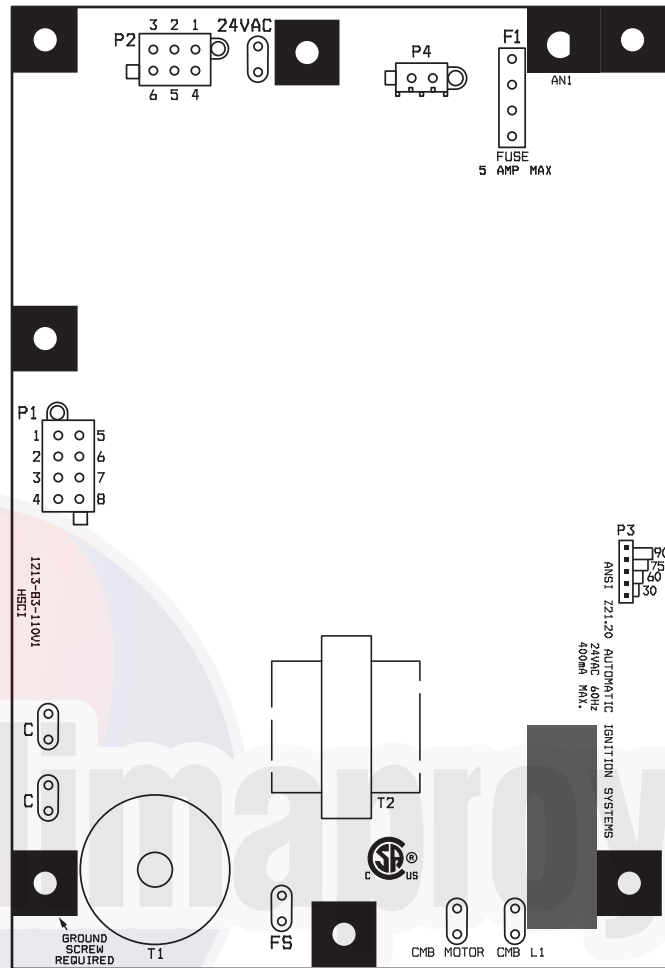

Fig. 38 — Integrated Gas Control (IGC) Board

Table 29 — Integrated Gas Control (IGC) Board Connections

TERMINAL LABEL	POINT DESCRIPTION	SENSOR LOCATION	TYPE OF I/O	CONNECTION PIN NUMBER
Inputs				
RT, C	Power for IDR on 575v units	Control box	24 VAC	Spade
C	Input power common			Spade
SS	Speed sensor	Gas section	Analog input	J1, 1-3
FS, T1	Flame sensor	Gas section	Switch input	Spade
W	Heat stage 1 Call	MBB to IGC	24 VAC	J2, 2
G	Indoor Fan Call	Not used	24 VAC	J2, 3
R	Input power from TRAN 1	TB4 to IGC	24 VAC	J2, 4
RS	Rollout switch	Gas section	Switch input	J2, 5-6
LS	Limit switch	Gas section	Switch input	J2, 7-8
CS	Centrifugal switch (not used)		Switch input	J2, 9-10
Outputs				
L1, CM	Induced draft combustion motor or relay	Gas section	Line VAC	
IFO	Indoor fan request	IGC to MBB	Relay	J2, 1
GV (W1)	Gas valve (heat stage 1)	Gas section	Relay	J2, 12
GV (W2)	Gas Valve (heat stage 2, from CTB)	Gas section	Not on IGC	

Protective Devices

COMPRESSOR PROTECTION

Overcurrent

Each compressor has internal line break motor protection.

Overtemperature

Each compressor has an internal protector to protect it against excessively high discharge gas temperatures.

High-Pressure Switch

If the high-pressure switch trips, the compressor will shut down and the Circuit A High Pressure Alert will activate. Refer to the alarm section for the High pressure alert.

EVAPORATOR FAN MOTOR PROTECTION

In the belt drive application, the VFD serves as the motor thermal and over-current protection. Refer to page 48 for more detail on the VFD.

⚠ CAUTION

EQUIPMENT DAMAGE HAZARD

Failure to follow this caution may result in unit damage.

DO not bypass the VFD while running the motor. Do not change VFD parameter associated with motor characteristics, these are factory programmed for motor protection. Damage to the motor or the VFD can occur.

CONDENSER-FAN MOTOR PROTECTION

The ECM motor is protected from locked rotor and over-current protection through the electronic control module attached to the motor.

SATURATED SUCTION PRESSURE (SSP)

If the SSP for a particular circuit is reading below the alarm set point for an extended period of time, that circuit will be shut down. After 15 minutes, the alarm will automatically reset. If this alarm occurs 3 times consecutively, the circuit will remain locked out until an alarm reset is initiated via CCN or manually via the SystemVu™ controller display (see “Faults and Alerts” on page 32 for more details).

CONDENSATE OVERFLOW SWITCH (COFS)

A separate factory-installed device can detect a full drain pan. This device consists of a pan sensor to detect the water level and a relay control switch to read the sensor. The control switch is located in the unit control box and feeds into the SystemVu control to trip a condensate overflow fault. The relay switch is a normally open device that closes when power is applied. If the sensor detects high water levels for 10 seconds straight, it will open the contact removing the input provided to the SystemVu control. The switch will also turn its red LED on. If the water level is low enough for 5 minutes, the relay will close again applying the input back to the SystemVu controller. A blinking red LED on the switch indicates that the sensor has been disconnected.

Space Mounted Sensors

SPACE TEMPERATURE SENSOR (T-55)

The T-55 space temperature sensor (part no. 33ZCT55SPT) is a field-installed accessory. The sensor is installed on a building interior wall to measure room air temperature. The T-55 sensor also includes an override button on the front cover to permit occupants to override the Unoccupied Schedule (if programmed).

TB5-1 Sensor Input

TB5-2 Sensor Common

SPACE TEMPERATURE SENSOR (T-56)

The T-56 space temperature sensor (part no. 33ZCT56SPT) is a field-installed accessory. This sensor includes a sliding scale on the front cover that permits an occupant to adjust the space temperature set point remotely. The T-56 sensor also includes an override button on the front cover to allow occupants to override the unoccupied schedule (if programmed).

TB5-1 Sensor Input

TB5-2 Sensor Common

TB5-3 Setpoint Offset Input

SPACE TEMPERATURE SENSOR AVERAGING

See Fig. 39 for space temperature averaging with T-55 sensors only. If the use of one T-56 sensor is required, refer to Fig. 40.

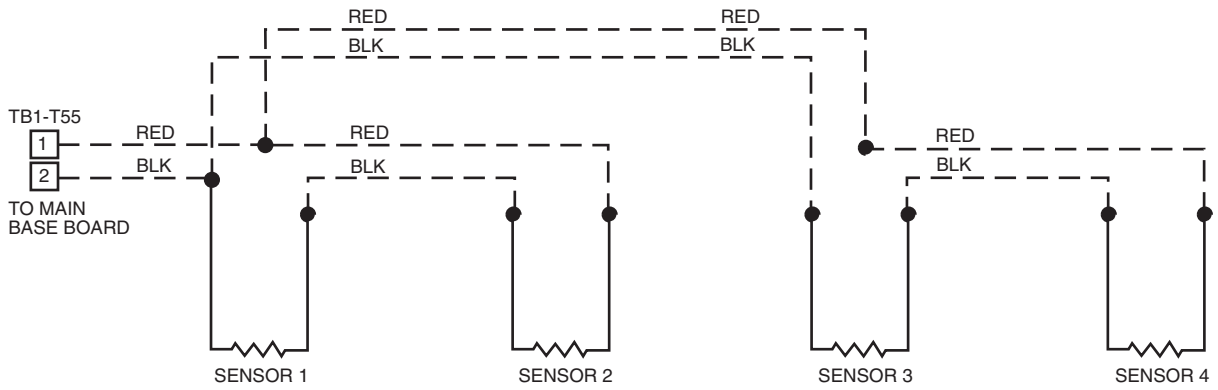

SPACE TEMPERATURE AVERAGING — 4 T-55 SENSOR APPLICATION

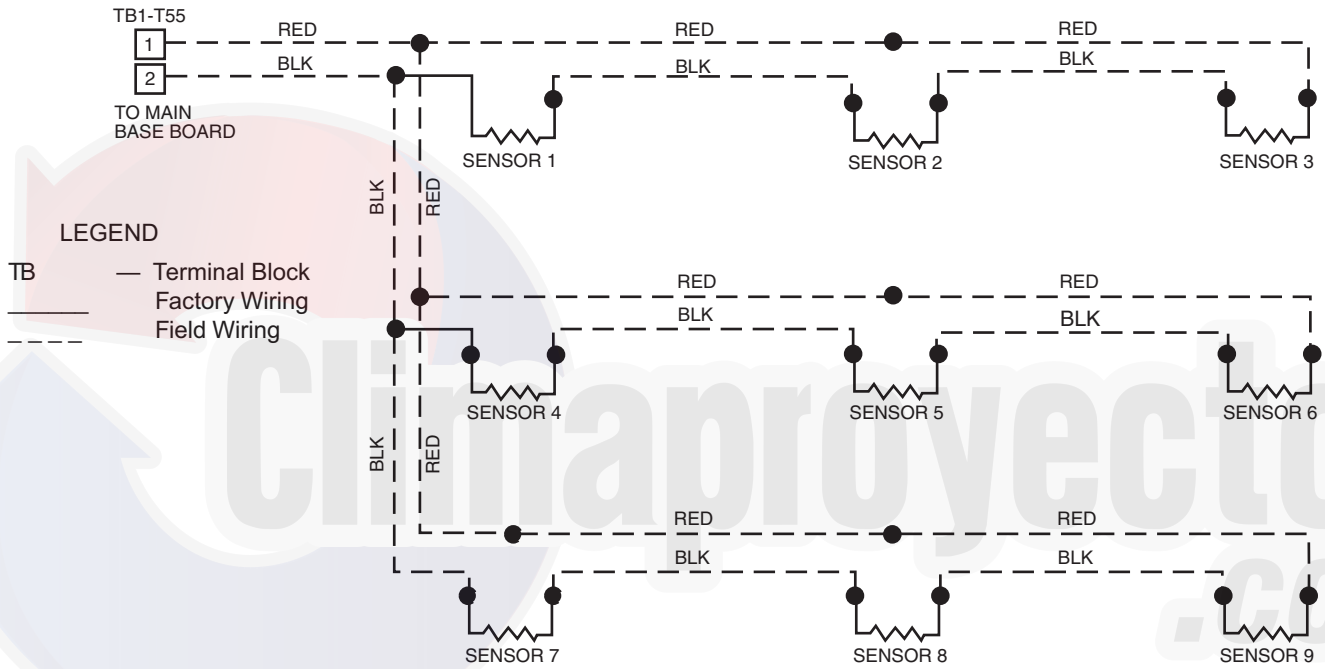

SPACE TEMPERATURE AVERAGING — 9 T-55 SENSOR APPLICATION

Fig. 39 — Space Temperature Sensor Averaging

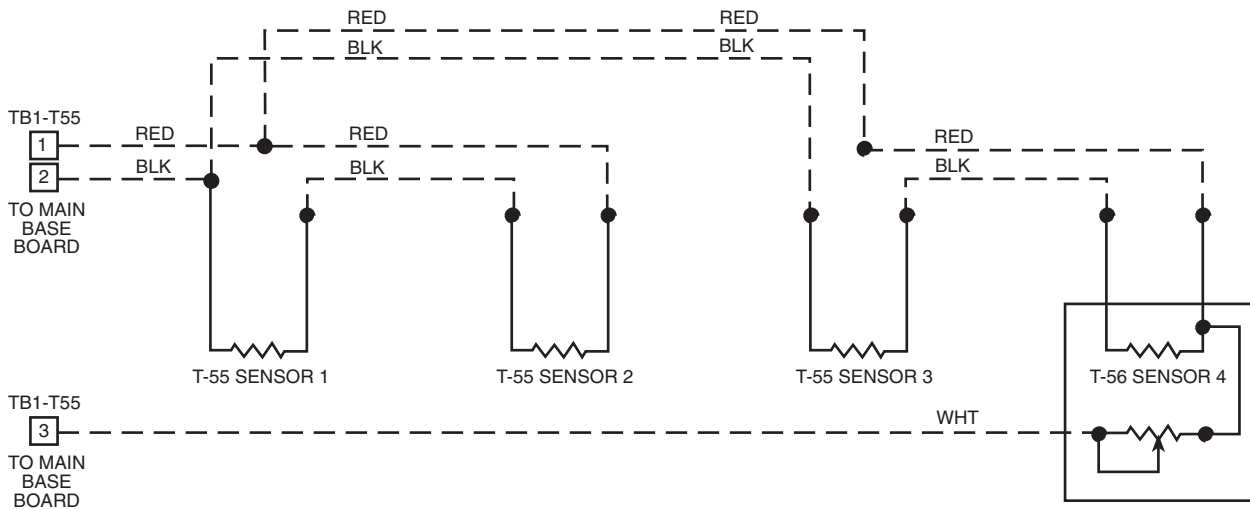

Fig. 40 — Space Temperature Sensor Averaging with 3 T-55 Sensors and One T-56 Sensor

Variable Frequency Drive (VFD)

VFDs are available as a factory-installed option for 48/50LC series units. 04-06 units use ABB VFDs, while 07-26 units use Danfoss VFDs. For details on 07-26 units with VFDs, see “48/50LC 07-26 Variable Frequency Drive (Danfoss VFD)” on page 77.

48/50LC 04-06 VARIABLE FREQUENCY DRIVE (ABB VFD)

On units equipped with supply fan VFDs, the indoor fan motor is controlled by a 3-phase VFD. The supply fan VFD is located in the supply fan section behind the access door. These units use ABB VFDs. The VFD varies the frequency of the AC voltage supplied to the indoor fan. This allows the variance in the speed of the fan. The VFD is always powered during normal operation and the fan is stopped by driving the speed to 0. Figure 41 and Table 30 show the VFD terminals and connections.

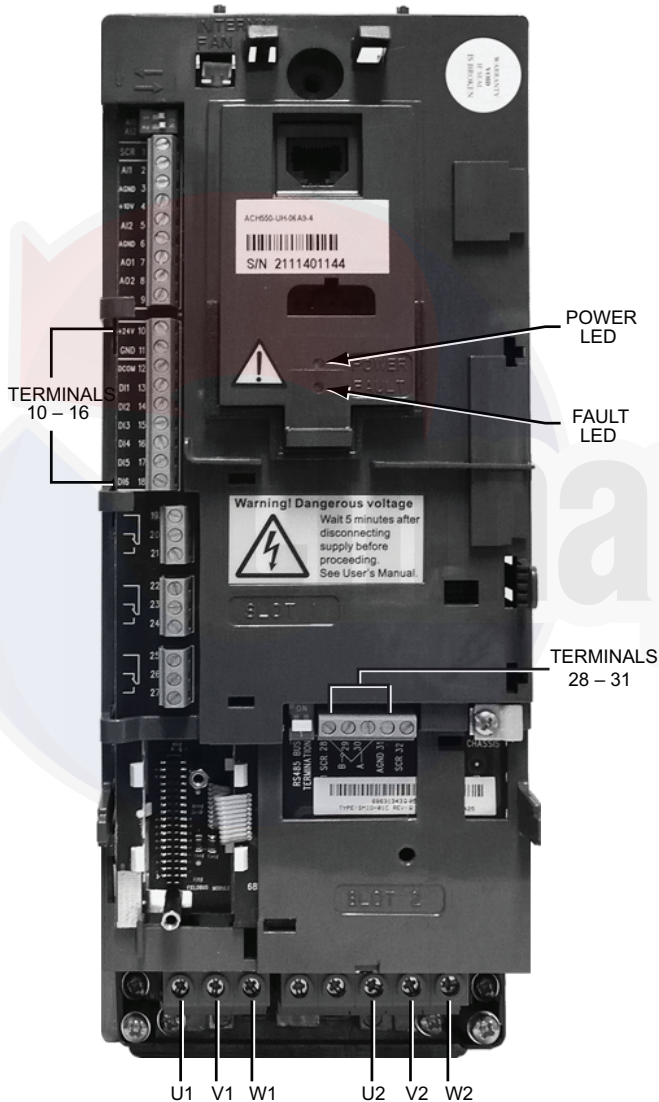

Fig. 41 — 48/50LC 04-06 Variable Frequency Drive (VFD) Terminals and Connections (Unit shown with front cover removed)

The VFD is factory-configured to match the current and power requirements for each motor selection and all wiring connections are completed by the factory; no field adjustments or connections are necessary. While the basic VFD retains all of its standard capabilities, this application uses only a limited portion of these features to provide discrete output speeds to the motor. Consequently, the VFD is not equipped with a keypad. A keypad is available as an accessory (P/N: CRDISKIT001A00) for field installation or expanded service access to VFD parameter and

troubleshooting tables. The VFD has soft start capabilities to slowly ramp up the speeds, eliminating any high inrush of air volume during speed changes.

Table 30 — 48/50LC 04-06 VFD Connections

POINT DESCRIPTION	TYPE OF I/O	TERMINAL NUMBER	TERMINAL NAME
Low Voltage Inputs			
Low Voltage Power (jumped to DI1 & DI4)	24 vdc	10	24v
Low Voltage Common (jumped to DCOM)	Ground	11	GND
Discrete Inputs Common (jumped from GND)	Ground	12	DCOM
Discrete Input 1 (jumped from 24v)	Switch Input	13	DI1
Not Used	Switch Input	14	DI2
Not Used	Switch Input	15	DI3
Discrete Input 4 (jumped from 24v)	Switch Input	16	DI4
Shielded Cable Ground	Shield	28	SCR
LEN communication	LEN	29	B+
LEN communication	LEN	30	A-
LEN communication	LEN	31	AGND
High Voltage			
Voltage Leg from C-11	Voltage Input	U1	MAINS
Voltage Leg from C-13	Voltage Input	V1	MAINS
Voltage Leg from IFTB	Voltage Input	W1	MAINS
Voltage Leg to IFM-3	Voltage Output	U2	MOTOR
Voltage Leg to IFM-2	Voltage Output	V2	MOTOR
Voltage Leg to IFM-1	Voltage Output	W2	MOTOR

⚠ CAUTION

EQUIPMENT DAMAGE AND PERFORMANCE HAZARD

Failure to follow this caution may result in damage to the unit or in degradation of unit performance.

Do not run the Carrier Assistant through the VFD keypad. This will cause parameters to change value that are not desired on these applications.

The VFDs communicate to the MBB over the local equipment network (LEN). The VFD speed is controlled directly by the SystemVu™ controller over the LEN. The VFD parameters required to allow the VFD to communicate on the LEN are shown in Table 31. Table 32 shows VFD parameters that are hard-coded by the SystemVu controller. The parameters listed in Table 32 have corresponding SystemVu configurations (**SETTINGS → UNIT CONFIGURATIONS → INDOOR FAN IFD → VFD PARAMETERS**). The factory sets these parameters per motor installed in the unit and these should not be adjusted in the field. These are only provided for drive or motor replacement. These parameters in Table 32 require the drive to be off or 0% to change them. See Tables 33 and 34 for VFD parameters through the SystemVu controller.

IMPORTANT: If the VFD appears to be communicating (the VFD software version can be read in **SERVICE → UNIT INFORMATION → VERSIONS**) but the loss of communications fault persists, place the keypad in the Off state. If communication is reestablished, the VFD had to be in the Off state to save the configurations being sent. This can occur after a VFD is replaced.

⚠ CAUTION

EQUIPMENT DAMAGE HAZARD

Failure to follow this warning could result in equipment damage.

The VFD motor parameters shown in Table 35 should never be changed in the field unless authorized by Carrier Corporation. Damage could occur to the motor or unit if these are set to anything besides what is shown in the table. These are only provided for drive or motor replacement or future adjustments.

For proper operation, there are three jumper wires that must remain installed and the VFD must be set to the auto mode. The 3 jumpers are shown on the unit schematic and are connected through a plug called PL25. These jumpers set the VFD to start enabled, run enabled, and tie the common bus together. The VFD has 2 LEDs on its front panel to indicate operating status. See below and VFD Troubleshooting section for details on VFD faults and alarms. The VFD faults can be reset with the VFD keypad or through the SystemVu™ controller (**ALERTS/FAULTS** → **RESET FAULT/ALERT = Yes**).

The Green LED on steady indicates power is on the VFD, flashing Green indicates an alarm condition detected. Alarms are advisory in nature. These indicate a problem has been detected by the VFD's diagnostics but this problem will not require a shutdown.

The Red LED steady or flashing indicates a fault condition is detected. A fault is a significant internal situation for the VFD or Motor. Faults will typically shutdown the motor.

48/50LC 04-06 VFD TROUBLESHOOTING

When communication is successful, the SystemVu control will provide alerts and faults that correlate to the VFD's warnings and alarms. Table 36 shows the list of the SystemVu controller faults and alerts and how they map to the VFD warnings and alarms. Table 36 also lists the possible causes of these cases.

VFD Diagnostics (with Keypad)

The drive detects error situations and reports them using:

1. Green and red LEDs on the body of the drive (located under the keypad)
2. Status LED on the control panel
3. Control panel display
4. The Fault Word and Alarm Word parameter bits (parameters 0305 to 0309)

The form of the display depends on the severity of the error. The user can specify the severity for many errors by directing the drive to ignore the error situation, report the situation as an alarm, or report the situation as a fault.

Faults (Red LED Lit)

The VFD signals that it has detected a severe error, or fault, by:

1. Enabling the red LED on the drive (LED is either steady or flashing)
2. Setting an appropriate bit in a Fault Word parameter (0305 to 0307)

3. Overriding the control panel display with the display of a fault code
4. Stopping the motor (if it was on)

The fault code on the control panel display is temporary. Pressing the MENU, ENTER, UP or DOWN buttons removes the fault message. The message reappears after a few seconds if the control panel is not touched and the fault is still active.

Alarms (Green LED Flashing)

For less severe errors, called alarms, the diagnostic display is advisory. For these situations, the drive is simply reporting that it has detected something unusual. In these situations, the drive:

1. Flashes the green LED on the drive (does not apply to alarms that arise from control panel operation errors)
2. Sets an appropriate bit in an Alarm Word parameter (0308 or 0309)
3. Overrides the control panel display with the display of an alarm code and/or name

Alarm messages disappear from the control panel display after a few seconds. The message returns periodically as long as the alarm condition exists.

Correcting Faults

The recommended corrective action for faults is shown in the Fault Codes list in Table 36. The VFD can also be reset to remove the fault. If an external source for a start command is selected and is active, the VFD may start immediately after fault reset.

To reset a fault indicated by a flashing red LED, turn off the power for 5 minutes. To reset a fault indicated by a red LED (not flashing), press RESET from the control panel or turn off the power for 5 minutes. Depending on the value of parameter 1604 (FAULT RESET SELECT), digital input or serial communication could also be used to reset the drive. When the fault has been corrected, the motor can be started.

History

For reference, the last three fault codes are stored into parameters 0401, 0412, 0413. For the most recent fault (identified by parameter 0401), the drive stores additional data (in parameters 0402 through 0411) to aid in troubleshooting a problem. For example, a parameter 0404 stores the motor speed at the time of the fault. To clear the fault history (all of Group 04, Fault History parameters), follow these steps:

1. In the control panel, Parameters mode, select parameter 0401.
2. Press EDIT.
3. Press the UP and DOWN buttons simultaneously.
4. Press SAVE.

If diagnostics troubleshooting has determined that the drive is defective during the warranty period, contact ABB Automation Inc., at 1-800-435-7365, option 4, option 3. A qualified technician will review the problem with the caller and make a determination regarding how to proceed. This may involve dispatching a designated service station (DSS) representative from an authorized station, dispatching a replacement unit, or advising return for repair.

Table 31 — 48/50LC 04-06 VFD Parameters Configured by Factory or by VFD Keypad

PARAMETER GROUP	PARAMETER TITLE	ABB PARAMETER	HVAC DEFAULT	CARRIER
Options	COMM PROT SEL	9802	NOT SEL	LEN (6)
EVB Protocol	EVB PROTOCOL ID	5301	0000 hex	0601 hex
	EVB STATION ID	5302	0	41
	EVB BAUD RATE	5303	9.6 kb/s	38.4 kb/s
	EVB PARITY	5304	8 NONE 1	8 NONE 1
	EVB CTRL PROFILE	5305	ABB DRV LIM	DCU PROFILE

Table 32 — 48/50LC 04-06 VFD Parameters Hard Coded by SystemVu™ Controller

PARAMETER GROUP	PARAMETER TITLE	ABB PARAMETER	HVAC DEFAULT	CARRIER
Start/Stop/Dir	EXT1 COMMANDS	1001	DI1	COMM (2)
Reference Select	REF1 SELECT	1103	AI1	COMM (2)
Constant Speeds	CONST SPEED 7	1208	60 Hz	0 Hz
System Controls	RUN ENABLE	1601	NOT SEL	NOT SEL (0)
	FAULT RESET SEL	1604	KEYPAD	COMM (7)
	START ENABLE 1	1608	DI4	DI4 (4)
Start/Stop	START FUNCTION	2101	SCALAR FLYSTART	AUTO (0)
	STOP FUNCTION	2102	COAST	COAST (1)
Fault Functions	COMM FAULT FUNC	3018	NOT SEL	CONST SP 7 (2)
	COMM FAULT TIME	3019	10.0 s	10.0 s
Start/Stop/Dir	DIRECTION	1003	FORWARD	REQUEST
Accel/Decel	ACCELER TIME 1	2202	30.0s	30.0s
	DECELER TIME 1	2203	30.0s	10.0s
Motor Control	SWITCHING FREQ	2606	4 kHz	4 kHz
Start-Up Data	MOTOR NOM VOLT	9905	230V, 460V, 575V	See Table 35
	MOTOR NOM CURR	9906	10*In	See Table 35
	MOTOR NOM FREQ	9907	60 Hz	60 Hz
	MOTOR NOM SPEED	9908	1750 rpm	See Table 35
	MOTOR NOM POWER	9909	1.0*Pn	See Table 35
Limits	MAXIMUM CURRENT	2003	1.3*i2n	See Table 35

Table 33 — 48/50LC 04-06 VFD Parameters Configurable Through SystemVu Controller

PARAMETER GROUP	PARAMETER TITLE	ABB PARAMETER	HVAC DEFAULT	CARRIER	CCN POINT	DISPLAY MENU ITEM
Accel/Decel	ACCELER TIME 1	2202	30.0s	30.0s	RAMPUP_T	VFD ACCEL TIME
	DECELER TIME 1	2203	30.0s	10.0s	RAMPDN_T	VFD DECEL TIME
Start-Up Data	MOTOR NOM VOLT	9905	230V, 460V, 575V	See Table 35	MOTVOLT	IDF VFD VOLTAGE
	MOTOR NOM CURR	9906	1.0*In	See Table 35	MOTCUR	IDF VFD NOM. AMPS
	MOTOR NOM FREQ	9907	60 Hz	60 Hz	MOTFREQ	IDF VFD NOM. FREQ
	MOTOR NOM SPEED	9908	1750 rpm	See Table 35	MOTNOMSP	IDF VFD NOM. RPM
	MOTOR NOM POWER	9909	1.0*Pn	See Table 35	MOTPWRHP	IDF VFD NOM. HP
Limits	MAXIMUM CURRENT	2003	1.3*i2n	See Table 35	CURRLMT	IDF VFD MAX AMPS

Table 34 — 48/50LC 04-06 VFD Status Parameters Available Through SystemVu Controller

PARAMETER GROUP	PARAMETER TITLE	ABB PARAMETER	UNITS	SYSTEMVU POINT	SYSTEMVU DISPLAY ITEM
Operating Data	Run Time	0114	h	RUNHOURS	IDF VFD RUN HOURS
	kWh Counter	0115	kWh	KWHCNR	IDF VFD KW HOURS
	Power	0106	kW	OUTPWRKW	VFD OUTPUT KW
	Output Voltage	0109	v	OUTMVOLT	VFD OUTPUT VOLTS
	Output Frequency	0103	Hz	OUTMFREQ	VFD OUTPUT FREQ
	CURRENT	0104	A	OUTMCUR	VFD OUTPUT AMPS
	DC Bus Voltage	0107	v	DLCNVOLT	IDF VFD DC VOLTS
	Drive Temp	0110	°C	HTSINKT	IDF VFD HSNK TEMP

Table 35 — 48/50LC 04-06 VFD Motor Default Configurations

EQUIPMENT MODEL NUMBER (EQ_MOD)				NOMINAL HORSE POWER	MOTOR VOLTAGE	MOTOR CURRENT (MUST-HOLD AMPS)	MOTOR NOMINAL SPEED (RPM)	VFD MAX AMPS
Position 1,2	Position 7,8	Position 10	Position 12	MOTPWHP	MOTVOLT	MOTCUR	MOTNOMSP	VFD1MAXA
48	04	2	5	1.7	230	5.8	1725	6.7
			6	1.7	460	2.9	1725	3.3
			1	1.7	575	3.1	1725	3.6
		3	5	2.4	230	7.9	1725	9.1
			6	2.4	460	2.9	1725	4.6
			1	2.4	575	3.4	1725	3.9
	05	2	5	1.7	230	5.8	1725	6.7
			6	1.7	460	2.9	1725	3.3
			1	1.7	575	3.1	1725	3.6
		3	5	2.9	230	9.2	1725	10.6
			6	2.9	460	4.6	1725	5.3
			1	3.7	575	4.2	1725	4.8
	06	2	5	2.4	230	7.9	1725	9.1
			6	2.4	460	4.0	1725	4.6
			1	2.4	575	3.4	1725	3.9
		3	5	2.9	230	9.2	1725	10.6
			6	2.9	460	4.6	1725	5.3
			1	3.7	575	4.2	1725	4.8
50	04	2	5	1.7	230	5.8	1725	6.7
			6	1.7	460	2.9	1725	3.3
			1	1.7	575	3.1	1725	3.6
		3	5	2.4	230	7.9	1725	9.1
			6	2.4	460	2.9	1725	4.6
			1	2.4	575	3.4	1725	3.9
	05	2	5	1.7	230	5.8	1725	6.7
			6	1.7	460	2.9	1725	3.3
			1	1.7	575	3.1	1725	3.6
		3	5	2.9	230	9.2	1725	10.6
			6	2.9	460	4.6	1725	5.3
			1	3.7	575	4.2	1725	4.8
	06	2	5	2.4	230	7.9	1725	9.1
			6	2.4	460	4.0	1725	4.6
			1	2.4	575	3.4	1725	3.9
		3	5	2.9	230	9.2	1725	10.6
			6	2.9	460	4.6	1725	5.3
			1	3.7	575	4.2	1725	4.8

Table 36 — 48/50LC 04-06 VFD Fault Codes

SYSTEMVU FAULT	SYSTEMVU ALERT	ABB ALARM CODE	ALARM DESCRIPTION	CAUSE OF PROBLEM AND CORRECTIVE ACTION
F613-IDF VFD OVER CURRENT	A607-IDF VFD CURRENT LIMIT	1	Over Current	Output current is excessive. Check for excessive motor load, insufficient acceleration time (parameters 2202 ACCELER TIME 1, default 30 seconds), or faulty motor, motor cables or connections.
F617-IDF VFD OVER VOLTAGE	A606-IDF VFD VOLTAGE WARNING	2	DC Over Voltage	Intermediate circuit DC voltage is excessive. Check for static or transient over voltages in the input power supply, insufficient deceleration time (parameters 2203 DECELER TIME 1, default 30 seconds), or undersized brake chopper (if present).
F601-IDF VFD UNEXPECTED	A605-IDF VFD THERMAL WARNING	3	Device Over Temp	Drive heat sink is overheated. Temperature is at or above 115°C (239°F). Check for fan failure, obstructions in the air flow, dirt or dust coating on the heat sink, excessive ambient temperature, or excessive motor load.
F618-IDF VFD SHORT CIRCUIT	—	4	Short Circuit	Fault current. Check for short-circuit in the motor cable(s) or motor or supply disturbances.
F616-IDF VFD UNDER VOLTAGE	A606-IDF VFD VOLTAGE WARNING	6	DC Under Volt	Intermediate circuit DC voltage is not sufficient. Check for missing phase in the input power supply, blown fuse, or under voltage on main circuit.
F614-IDF VFD MOTOR OVER TEMP	A605-IDF VFD THERMAL WARNING	9	Motor Over Temp	Motor is too hot, as estimated by the drive. Check for overloaded motor. Adjust the parameters used for the estimate (3005 through 3009). Check the temperature sensors and Group 35 parameters.
F611-IDF VFD EARTH FAULT	A608-IDF VFD WARNING	16	Earth Fault	The load on the input power system is out of balance. Check for faults in the motor or motor cable. Verify that motor cable does not exceed maximum specified length.
F619-IDF VFD MAIN PHASE LOSS	A608-IDF VFD WARNING	22	Supply Phase	Ripple voltage in the DC link is too high. Check for missing main phase or blown fuse.

48/50LC 07-26 Variable Frequency Drive (Danfoss VFD)

The indoor fan motor is controlled by a VFD. The supply fan VFD is located in the supply fan section behind the access door. The VFD varies the frequency of the AC voltage supplied to the indoor fan. This allows the variation in the speed of the fan. The VFD is always powered during normal operation and the fan is stopped by driving the speed to 0. Figure 42 and Table 37 show the VFD terminals and connections.

The VFD is factory-configured to match the current and power requirements for each motor selection and all wiring connections are completed by the factory; no field adjustments are necessary. The VFD used has soft start capabilities to slowly ramp up the speeds, eliminating any high inrush of air volume during speed changes. While the basic VFD retains all of its standard capabilities, the 48/50LC unit uses only a limited portion of these features to provide discrete output speeds to the motor. The VFD is not equipped with a keypad. A keypad is available as an accessory (P/N: CRDISKIT002A00) for field installation or expanded service access to VFD parameter and troubleshooting tables.



Fig. 42 — Variable Frequency Drive (VFD) Terminals and Connections (Unit shown with front cover removed)

Table 37 — VFD Connections

POINT DESCRIPTION	TYPE OF I/O	TERMINAL NUMBER	TERMINAL NAME
Low Voltage Inputs			
Low Voltage Power (jumped to 18 and 27)	24vdc	12	+24v
Discrete Inputs Common	Ground	20	GND
Analog Inputs Common	Ground	55	GND
Terminal 18 Discrete Input (jumped from 24v)	Switch Input	18	DIG IN
Not Used	Switch Input	19	DIG IN
Terminal 27 Discrete Input (jumped from 24v)	Switch Input	27	DIG IN
Not Used	Switch Input	29	DIG IN
LEN communication +	LEN+	68	P
LEN communication -	LEN-	69	N
LEN Communication Common	LEN C	61	COMM. GND
High Voltage			
Voltage Leg from C-11	Voltage Input	L1	MAINS
Voltage Leg from C-13	Voltage Input	L2	MAINS
Voltage Leg from IFTB	Voltage Input	L3	MAINS
Voltage Leg to IFM-3	Voltage Output	U	MOTOR
Voltage Leg to IFM-2	Voltage Output	V	MOTOR
Voltage Leg to IFM-1	Voltage Output	W	MOTOR

The VFD communicates to the MBB over the local equipment network (LEN). The VFD speed is controlled directly by the controller over the LEN. The VFD parameters required for the VFD to communicate on the LEN are shown in Table 38. Table 39 shows VFD parameters that are hard-coded by the SystemVu™ controller. The parameters listed in Table 40 have corresponding SystemVu controller configurations (*SETTINGS → UNIT CONFIGURATIONS → INDOOR FAN → IFD VFD PARAMETERS*). The factory sets these parameters per the motor installed in the unit and these should not be adjusted in the field. These are only provided for drive or motor replacement. These parameters in Table 40 require the drive to be off or at 0% to change them. See Table 41 for VFD parameters available through the SystemVu controller.

⚠ CAUTION
<p>EQUIPMENT DAMAGE HAZARD</p> <p>Failure to follow this warning could result in equipment damage.</p> <p>The VFD motor parameters shown in Table 42 should never be changed in the field unless authorized by Carrier Corporation. Damage could occur to the motor or unit if these are set to anything besides what is shown in the table. These are only provided for drive or motor replacement or future adjustments.</p>

Table 38 — 48/50LC 07-26 VFD Parameters Configured by Factory or by VFD Keypad

PARAMETER GROUP	PARAMETER TITLE	DANFOSS PARAMETER	VFD DEFAULT	CARRIER
Reset Functions	Service Code	14-29	6333	6222
	PROTOCOL	8-30	(0) FC	(20) LEN
FC Port Settings	ADDRESS	8-31	1	180
	BAUD RATE	8-32	(2) 9.6 kb/s	(4) 38.4 kb/s
	Parity/Stop Bits	8-33	(0) 8 EVEN 1	(2) 8 NONE 1

Table 39 — 48/50LC 07-26 VFD Parameters Hard Coded by SystemVu™ Controller

PARAMETER GROUP	PARAMETER TITLE	DANFOSS PARAMETER	VFD DEFAULT	CARRIER
Basic Settings	Regional Settings	0-03	International (0)	North America (1)
General Settings	Configuration Mode	1-00	Open Loop (0)	Open Loop (0)
	Torque Characteristics	1-03	Variable Torque (1)	Variable Torque (1)
	Clockwise Direction	1-06	Normal (0)	Normal (0)
Motor Selection	Motor Construction	1-10	Asynchron (0)	Asynchron (0)
Start Adjustments	Start Delay	1-71	0s	0s
	Start Function	1-72	Coast/delay time (2)	Coast/delay time (2)
	Flying Start	1-73	Disabled (0)	Disabled (0)
Motor Temperature	Motor Thermal Protection	1-90	No Protection (0)	ETR trip 1 (4)
Brake Energy Funct.	Over-voltage Control	2-17	Enabled (2)	Enabled (2)
References	Preset Reference	3-10	%00005	%00005
	Reference 3 Source	3-17	Local bus reference (11)	Local bus reference (11)
Motor Limits	Motor Speed Direction	4-10	Both directions (2)	Both directions (2)
	Motor Speed Low Limit [Hz]	4-12	0 Hz	0 Hz
	Motor Speed High Limit [Hz]	4-14	65 Hz	65 Hz
Digital Inputs	Terminal 18 Digital Input	5-10	8	Start (8)
	Terminal 27 Digital Input	5-12	Coast Inverse (2)	No Operation (0)
Relays	Function Relay (Relay 1)	5-40	No Function (0)	Bus Control (45)
	Function Relay (Relay 2)	5-40	No Function (0)	Bus Control (45)
Analog/Digital Output	Terminal 45 Mode	6-70	0-20 mA (0)	4-20 mA (1)
	Terminal 45 Analog Output	6-71	No Operation (0)	Bus Control (139)
	Terminal 45 Output Min Scale	6-73	%00005	%00005
	Terminal 42 Mode	6-90	0-20 mA (0)	0-20 mA (0)
	Terminal 42 Analog Output	6-91	No Operation (0)	Bus Control (139)
	Terminal 42 Output Min Scale	6-93	%00005	%00005
General Settings	Control Site	8-01	Digital and ctrl.word (0)	Digital and ctrl.word (0)
	Control Source	8-02	FC Port (1)	FC Port (1)
	Control Timeout Function	8-04	Off (0)	Stop and trip (5)
Digital/Bus	Start Select	8-53	Logic OR (3)	Logic AND (2)
SLC Settings	SL Controller Mode	13-00	Off (0)	Off (0)
Inverter Switching	Switching Frequency	14-01	5.0khz (5)	5.0khz (5)
Mains On/Off	Function at Mains Imbalance	14-12	Trip (0)	Trip (0)
Reset Functions	Reset Mode	14-20	Manual Reset (0)	Automatic reset x 3 (3)

Table 40 — 48/50LC 07-26 VFD Parameters Configurable Through SystemVu Controller

PARAMETER GROUP	PARAMETER TITLE	DANFOSS PARAMETER	HVAC DEFAULT	CARRIER	CCN POINT	DISPLAY MENU ITEM
Motor Data	Motor Power	1-20	drive dep.	See Table 42 or 43	MOTPHP	IDF VFD NOM HP
	Motor Voltage	1-22	drive dep.	See Table 42 or 43	MOTVOLT	IDF VFD VOLTAGE
	Motor Frequency	1-23	50 Hz	60 Hz	MOTFREQ	IDF VFD NOM. FREQ
	Motor Current	1-24	drive dep.	See Table 42 or 43	MOTCUR	IDF VFD NOM. AMPS
	Motor Nominal Speed	1-25	drive dep.	See Table 42 or 43	MOTNOMSP	IDF VFD NOM. RPM
Reference Limits	Minimum Reference	3-02	0 Hz	0 Hz	MINREF	IDF VFD MIN REF
	Maximum Reference	3-03	50 Hz	60 Hz	MAXREF	IDF VFD MAX REF
Ramp 1	Ramp 1 Ramp Up Time	3-41	3 s	10 s	RAMPUP_T	VFD ACCEL. TIME
	Ramp 1 Ramp Down Time	3-42	3 s	30 s	RAMPDN_T	VFD DECEL. TIME
Motor Limits	Current Limit	4-18	110%	100%	CURRLMT	IDF VFD AMP LIMIT
General Settings	Control Timeout Time	8-03	1 s	30 s	CNT_TOUT	IDF VFD TIMEOUT
Reset Functions	Automatic Restart Time	14-21	10 s	30 s	ARSTRT_T	IDF VFD RESET DUR
Environment	RFI Filter	14-50	On (1)	On (1)	RFIFILTR	VFD RFI FILTER

Table 41 — 48/50LC 07-26 VFD Status Parameters Available Through SystemVu™ Controller

PARAMETER GROUP	PARAMETER TITLE	DANFOSS PARAMETER	UNITS	SYSTEMVU POINT	SYSTEMVU DISPLAY ITEM
Operating Data	Running Hours	15-01	h	RUNHOURS	IDF VFD RUN HOURS
	kWh Counter	15-02	kWh	KWHCNTR	IDF VFD KW HOURS
General Status	Reference [%]	16-02	%	REFSPEED	VFD REF SPEED
	Status Word	16-03		STATUSWD	VFD STATUS WORD
	Main Actual Value [%]	16-05	%	MAV	IDF VFD FEEDBACK
Motor Status	Power [kW]	16-10	kW	OUTPWRKW	VFD OUTPUT KW
	Power [hp]	16-11	hp	OUTPWRHP	VFD OUTPUT HP
	Motor Voltage	16-12	v	OUTMVOLT	VFD OUTPUT VOLTS
	Frequency	16-13	Hz	OUTMFREQ	VFD OUTPUT FREQ
	Motor current	16-14	A	OUTMCUR	VFD OUTPUT AMPS
Drive Status	DC Link Voltage	16-30	v	DCLNVOLT	IDF VFD DC VOLTS
	Heatsink Temp.	16-34	°C	HTSINKT	IDF VFD HSNK TEMP
Diagnostic Readouts	Alarm Word	16-90		ALMERRC	IDF VFD ALM WORD

NOTE: Table 41 lists the status information the VFD sends to the SystemVu controls. This table is updated at every scan the controls perform of the LEN. This occurs approximately once every second.

Table 42 — 48/50LC 07-26 VFD Motor Default Configurations - Vertical Airflow Units

EQUIPMENT MODEL NUMBER (EQ_MOD)				NOMINAL HORSE POWER	MOTOR VOLTAGE	MOTOR CURRENT (MUST-HOLD AMPS)	MOTOR NOMINAL SPEED (RPM)	VFD MAX AMPS
Position 1,2	Position 7,8	Position 10	Position 12	MOTPWRHP	MOTVOLT	MOTCUR	MOTNOMSP	VFD1MAXA
48	07	1	5	1.7	230	5.8	1695	5.8
			6	1.7	460	2.9	1690	2.9
			1	1.7	575	3.1	1690	3.1
		2	5	1.7	230	5.8	1695	5.8
			6	1.7	460	2.9	1690	2.9
			1	1.7	575	3.1	1690	3.1
		3	5	2.9	230	9.2	1735	9.2
			6	2.9	460	4.2	1735	4.2
			1	2.9	575	4.9	1710	4.9
	08	1	5	1.7	230	5.8	1695	5.8
			6	1.7	460	2.9	1690	2.9
			1	1.7	575	3.1	1690	3.1
		2	5	2.4	230	7.9	1680	7.9
			6	2.4	460	3.6	1680	3.6
			1	2.4	575	3.8	1680	3.8
		3	5	3.7	230	11.7	1750	11.7
			6	3.7	460	5.4	1750	5.4
			1	3.7	575	4.9	1710	4.9
		4	5	5.0	230	13.6	1745	13.6
			6	5.0	460	6.8	1745	6.8
			1	5.0	575	6	1745	6.0
	09	1	5	1.7	230	5.8	1695	5.8
			6	1.7	460	2.9	1690	2.9
			1	1.7	575	3.1	1690	3.1
2		5	2.4	230	7.9	1680	7.9	
		6	2.4	460	3.6	1680	3.6	
		1	2.4	575	3.8	1680	3.8	
3		5	3.7	230	11.7	1750	11.7	
		6	3.7	460	5.4	1750	5.4	
		1	3.7	575	4.9	1710	4.9	
4		5	5.0	230	13.6	1745	13.6	
		6	5.0	460	6.8	1745	6.8	
		1	5.0	575	6	1745	6.0	

Table 42 — 48/50LC 07-26 VFD Motor Default Configurations - Vertical Airflow Units (cont)

EQUIPMENT MODEL NUMBER (EQ_MOD)				NOMINAL HORSE POWER	MOTOR VOLTAGE	MOTOR CURRENT (MUST-HOLD AMPS)	MOTOR NOMINAL SPEED (RPM)	VFD MAX AMPS
Position 1,2	Position 7,8	Position 10	Position 12	MOTPWHP	MOTVOLT	MOTCUR	MOTNOMSP	VFD1MAXA
48 (cont)	12	1	5	2.4	230	7.9	1680	7.9
			6	2.4	460	3.6	1680	3.6
			1	2.4	575	3.8	1680	3.8
		2	5	3.7	230	11.7	1750	11.7
			6	3.7	460	5.4	1750	5.4
			1	3.7	575	4.9	1710	4.9
		3	5	5.0	230	13.6	1745	13.6
			6	5.0	460	6.8	1745	6.8
			1	5.0	575	6	1745	6.0
	14	1	5	2.9	230	9.2	1735	9.2
			6	2.9	460	4.2	1735	4.2
			1	2.9	575	4.9	1710	4.9
		2	5	5.0	230	13.6	1745	13.6
			6	5.0	460	6.8	1745	6.8
			1	5.0	575	6	1745	6.0
		3	5	7.5	230	21.2	1760	21.2
			6	7.5	460	9.7	1760	9.7
			1	7.5	575	7.2	1745	7.2
		4	5	10.0	230	28	1760	28.0
			6	10.0	460	13.7	1760	13.7
			1	10.0	575	8.9	1750	8.9
	17	1	5	2.9	230	9.2	1735	9.2
			6	2.9	460	4.2	1735	4.2
			1	2.9	575	4.9	1710	4.9
		2	5	7.5	230	21.2	1760	21.2
			6	7.5	460	9.7	1760	9.7
			1	7.5	575	7.2	1745	7.2
		3	5	10.0	230	28	1760	28.0
			6	10.0	460	13.7	1760	13.7
			1	10.0	575	8.9	1750	8.9
		4	5	15.0	230	37.3	1755	37.3
			6	15.0	460	16.9	1755	16.9
			1	15.0	575	12.6	1755	12.6
	20	1	5	2.9	230	11.7	1750	11.7
			6	2.9	460	5.4	1750	5.4
			1	2.9	575	4.9	1710	4.9
		2	5	7.5	230	21.2	1760	21.2
			6	7.5	460	9.7	1760	9.7
			1	7.5	575	7.2	1745	7.2
		3	5	10.0	230	28	1760	28.0
			6	10.0	460	13.7	1760	13.7
			1	10.0	575	8.9	1750	8.9
4		5	15.0	230	37.3	1755	37.3	
		6	15.0	460	16.9	1755	16.9	
		1	15.0	575	12.6	1755	12.6	
24	1	5	7.5	230	21.2	1760	21.2	
		6	7.5	460	9.7	1760	9.7	
		1	7.5	575	7.2	1745	7.2	
	2	5	10.0	230	28	1760	28.0	
		6	10.0	460	13.7	1760	13.7	
		1	10.0	575	8.9	1750	8.9	
	3	5	15.0	230	37.3	1755	37.3	
		6	15.0	460	16.9	1755	16.9	
		1	15.0	575	12.6	1755	12.6	

Table 42 — 48/50LC 07-26 VFD Motor Default Configurations - Vertical Airflow Units (cont)

EQUIPMENT MODEL NUMBER (EQ_MOD)				NOMINAL HORSE POWER	MOTOR VOLTAGE	MOTOR CURRENT (MUST-HOLD AMPS)	MOTOR NOMINAL SPEED (RPM)	VFD MAX AMPS		
Position 1,2	Position 7,8	Position 10	Position 12	MOTPWHP	MOTVOLT	MOTCUR	MOTNOMSP	VFD1MAXA		
48 (cont)	26	1	5	7.5	230	21.2	1760	21.2		
			6	7.5	460	9.7	1760	9.7		
			1	7.5	575	7.2	1745	7.2		
		2	26	2	5	10.0	230	28	1760	28.0
					6	10.0	460	13.7	1760	13.7
					1	10.0	575	8.9	1750	8.9
		3	26	3	5	15.0	230	37.3	1755	37.3
					6	15.0	460	16.9	1755	16.9
					1	15.0	575	12.6	1755	12.6
50	07	1	5	1.7	230	5.8	1695	5.8		
			6	1.7	460	2.9	1690	2.9		
			1	1.7	575	3.1	1690	3.1		
		2	07	2	5	1.7	230	5.8	1695	5.8
					6	1.7	460	2.9	1690	2.9
					1	1.7	575	3.1	1690	3.1
		3	07	3	5	2.9	230	9.2	1735	9.2
					6	2.9	460	4.2	1735	4.2
					1	2.9	575	4.9	1710	4.9
		08	1	1	5	1.7	230	5.8	1695	5.8
					6	1.7	460	2.9	1690	2.9
					1	1.7	575	3.1	1690	3.1
	2		08	2	5	1.7	230	5.8	1695	5.8
					6	1.7	460	2.9	1690	2.9
					1	1.7	575	3.1	1690	3.1
	3		08	3	5	2.9	230	9.2	1735	9.2
					6	2.9	460	4.2	1735	4.2
					1	2.9	575	4.9	1710	4.9
	4		08	4	5	3.7	230	13.6	1745	13.6
					6	3.7	460	6.8	1745	6.8
					1	3.7	575	6	1745	6.0
	09	1	1	5	1.7	230	5.8	1695	5.8	
				6	1.7	460	2.9	1690	2.9	
				1	1.7	575	3.1	1690	3.1	
		2	09	2	5	1.7	230	5.8	1695	5.8
					6	1.7	460	2.9	1690	2.9
					1	1.7	575	3.1	1690	3.1
		3	09	3	5	3.7	230	11.7	1750	11.7
					6	3.7	460	5.4	1750	5.4
					1	3.7	575	4.9	1710	4.9
		4	09	4	5	5.0	230	13.6	1745	13.6
					6	5.0	460	6.8	1745	6.8
					1	5.0	575	6	1745	6.0
	12	1	1	5	2.4	230	7.9	1680	7.9	
				6	2.4	460	3.6	1680	3.6	
				1	2.4	575	3.8	1680	3.8	
2		12	2	5	2.9	230	9.2	1735	9.2	
				6	2.9	460	4.2	1735	4.2	
				1	2.9	575	4.9	1710	4.9	
3		12	3	5	5.0	230	13.6	1745	13.6	
				6	5.0	460	6.8	1745	6.8	
				1	5.0	575	6	1745	6.0	

Table 42 — 48/50LC 07-26 VFD Motor Default Configurations - Vertical Airflow Units (cont)

EQUIPMENT MODEL NUMBER (EQ_MOD)				NOMINAL HORSE POWER	MOTOR VOLTAGE	MOTOR CURRENT (MUST-HOLD AMPS)	MOTOR NOMINAL SPEED (RPM)	VFD MAX AMPS
Position 1,2	Position 7,8	Position 10	Position 12	MOTPWRHP	MOTVOLT	MOTCUR	MOTNOMSP	VFD1MAXA
50 (cont)	14	1	5	2.9	230	9.2	1735	9.2
			6	2.9	460	4.2	1735	4.2
			1	2.9	575	4.9	1710	4.9
		2	5	5.0	230	13.6	1745	13.6
			6	5.0	460	6.8	1745	6.8
			1	5.0	575	6	1745	6.0
		3	5	7.5	230	21.2	1760	21.2
			6	7.5	460	9.7	1760	9.7
			1	7.5	575	7.2	1745	7.2
		4	5	10.0	230	28	1760	28.0
			6	10.0	460	13.7	1760	13.7
			1	10.0	575	8.9	1750	8.9
	17	1	5	2.9	230	9.2	1735	9.2
			6	2.9	460	4.2	1735	4.2
			1	2.9	575	4.9	1710	4.9
		2	5	7.5	230	21.2	1760	21.2
			6	7.5	460	9.7	1760	9.7
			1	7.5	575	7.2	1745	7.2
		3	5	10.0	230	28	1760	28.0
			6	10.0	460	13.7	1760	13.7
			1	10.0	575	8.9	1750	8.9
		4	5	15.0	230	37.3	1755	37.3
			6	15.0	460	16.9	1755	16.9
			1	15.0	575	12.6	1755	12.6
	20	1	5	2.9	230	11.7	1750	11.7
			6	2.9	460	5.4	1750	5.4
			1	2.9	575	4.9	1710	4.9
		2	5	7.5	230	21.2	1760	21.2
			6	7.5	460	9.7	1760	9.7
			1	7.5	575	7.2	1745	7.2
		3	5	10.0	230	28	1760	28.0
			6	10.0	460	13.7	1760	13.7
			1	10.0	575	8.9	1750	8.9
		4	5	15.0	230	37.3	1755	37.3
			6	15.0	460	16.9	1755	16.9
			1	15.0	575	12.6	1755	12.6
	24	1	5	7.5	230	21.2	1760	21.2
			6	7.5	460	9.7	1760	9.7
			1	7.5	575	7.2	1745	7.2
		2	5	7.5	230	21.2	1760	21.2
			6	7.5	460	9.7	1760	9.7
			1	7.5	575	7.2	1745	7.2
		3	5	10.0	230	28	1760	28.0
			6	10.0	460	13.7	1760	13.7
			1	10.0	575	8.9	1750	8.9
		4	5	15.0	230	37.3	1755	37.3
			6	15.0	460	16.9	1755	16.9
			1	15.0	575	12.6	1755	12.6
26	1	5	7.5	230	21.2	1760	21.2	
		6	7.5	460	9.7	1760	9.7	
		1	7.5	575	7.2	1745	7.2	
	2	5	10.0	230	28	1760	28.0	
		6	10.0	460	13.7	1760	13.7	
		1	10.0	575	8.9	1750	8.9	
	3	5	15.0	230	37.3	1755	37.3	
		6	15.0	460	16.9	1755	16.9	
		1	15.0	575	12.6	1755	12.6	

Table 43 — 48/50LC 14-26 VFD Motor Default Configurations - Horizontal Airflow Units

EQUIPMENT MODEL NUMBER (EQ_MOD)				NOMINAL HORSE POWER	MOTOR VOLTAGE	MOTOR CURRENT (MUST-HOLD AMPS)	MOTOR NOMINAL SPEED (RPM)	VFD MAX AMPS
Position 1,2	Position 7,8	Position 10	Position 12	MOTPWRHP	MOTVOLT	MOTCUR	MOTNOMSP	VFD1MAXA
48	14	5	5	2.9	230	9.2	1735	9.2
			6	2.9	460	4.2	1735	4.2
			1	2.9	575	4.9	1710	4.9
		6	5	5.0	230	13.6	1745	13.6
			6	5.0	460	6.8	1745	6.8
			1	5.0	575	6	1745	6.0
		7	5	7.5	230	21.2	1760	21.2
			6	7.5	460	9.7	1760	9.7
			1	7.5	575	7.2	1745	7.2
		8	5	10.0	230	28	1760	28.0
			6	10.0	460	13.7	1760	13.7
			1	10.0	575	8.9	1750	8.9
	17	5	5	2.9	230	9.2	1735	9.2
			6	2.9	460	4.2	1735	4.2
			1	2.9	575	4.9	1710	4.9
		6	5	7.5	230	21.2	1760	21.2
			6	7.5	460	9.7	1760	9.7
			1	7.5	575	7.2	1745	7.2
		7	5	10.0	230	28	1760	28.0
			6	10.0	460	13.7	1760	13.7
			1	10.0	575	8.9	1750	8.9
		8	5	15.0	230	37.3	1755	37.3
			6	15.0	460	16.9	1755	16.9
			1	15.0	575	12.6	1755	12.6
	20	5	5	2.9	230	11.7	1750	11.7
			6	2.9	460	5.4	1750	5.4
			1	2.9	575	4.9	1710	4.9
		6	5	7.5	230	21.2	1760	21.2
			6	7.5	460	9.7	1760	9.7
			1	7.5	575	7.2	1745	7.2
		7	5	10.0	230	28	1760	28.0
			6	10.0	460	13.7	1760	13.7
			1	10.0	575	8.9	1750	8.9
		8	5	15.0	230	37.3	1755	37.3
			6	15.0	460	16.9	1755	16.9
			1	15.0	575	12.6	1755	12.6
	24	5	5	7.5	230	21.2	1760	21.2
			6	7.5	460	9.7	1760	9.7
			1	7.5	575	7.2	1745	7.2
		6	5	10.0	230	28	1760	28.0
			6	10.0	460	13.7	1760	13.7
			1	10.0	575	8.9	1750	8.9
7		5	15.0	230	37.3	1755	37.3	
		6	15.0	460	16.9	1755	16.9	
		1	15.0	575	12.6	1755	12.6	
26		5	5	7.5	230	21.2	1760	21.2
			6	7.5	460	9.7	1760	9.7
			1	7.5	575	7.2	1745	7.2
	6	5	10.0	230	28	1760	28.0	
		6	10.0	460	13.7	1760	13.7	
		1	10.0	575	8.9	1750	8.9	
	7	5	15.0	230	37.3	1755	37.3	
		6	15.0	460	16.9	1755	16.9	
		1	15.0	575	12.6	1755	12.6	

Table 43 — 48/50LC 14-26 VFD Motor Default Configurations - Horizontal Airflow Units (cont)

EQUIPMENT MODEL NUMBER (EQ_MOD)				NOMINAL HORSE POWER	MOTOR VOLTAGE	MOTOR CURRENT (MUST-HOLD AMPS)	MOTOR NOMINAL SPEED (RPM)	VFD MAX AMPS
Position 1,2	Position 7,8	Position 10	Position 12	MOTPWRHP	MOTVOLT	MOTCUR	MOTNOMSP	VFD1MAXA
50	14	5	5	2.9	230	9.2	1735	9.2
			6	2.9	460	4.2	1735	4.2
			1	2.9	575	4.9	1710	4.9
		6	5	5.0	230	13.6	1745	13.6
			6	5.0	460	6.8	1745	6.8
			1	5.0	575	6	1745	6.0
		7	5	7.5	230	21.2	1760	21.2
			6	7.5	460	9.7	1760	9.7
			1	7.5	575	7.2	1745	7.2
		8	5	10.0	230	28	1760	28.0
			6	10.0	460	13.7	1760	13.7
			1	10.0	575	8.9	1750	8.9
	17	5	5	2.9	230	9.2	1735	9.2
			6	2.9	460	4.2	1735	4.2
			1	2.9	575	4.9	1710	4.9
		6	5	7.5	230	21.2	1760	21.2
			6	7.5	460	9.7	1760	9.7
			1	7.5	575	7.2	1745	7.2
		7	5	10.0	230	28	1760	28.0
			6	10.0	460	13.7	1760	13.7
			1	10.0	575	8.9	1750	8.9
		8	5	15.0	230	37.3	1755	37.3
			6	15.0	460	16.9	1755	16.9
			1	15.0	575	12.6	1755	12.6
	20	5	5	2.9	230	11.7	1750	11.7
			6	2.9	460	5.4	1750	5.4
			1	2.9	575	4.9	1710	4.9
		6	5	7.5	230	21.2	1760	21.2
			6	7.5	460	9.7	1760	9.7
			1	7.5	575	7.2	1745	7.2
		7	5	10.0	230	28	1760	28.0
			6	10.0	460	13.7	1760	13.7
			1	10.0	575	8.9	1750	8.9
		8	5	15.0	230	37.3	1755	37.3
			6	15.0	460	16.9	1755	16.9
			1	15.0	575	12.6	1755	12.6
	24	5	5	7.5	230	21.2	1760	21.2
			6	7.5	460	9.7	1760	9.7
			1	7.5	575	7.2	1745	7.2
		6	5	7.5	230	21.2	1760	21.2
			6	7.5	460	9.7	1760	9.7
			1	7.5	575	7.2	1745	7.2
		7	5	10.0	230	28	1760	28.0
			6	10.0	460	13.7	1760	13.7
			1	10.0	575	8.9	1750	8.9
		8	5	15.0	230	37.3	1755	37.3
			6	15.0	460	16.9	1755	16.9
			1	15.0	575	12.6	1755	12.6
	26	5	5	7.5	230	21.2	1760	21.2
			6	7.5	460	9.7	1760	9.7
			1	7.5	575	7.2	1745	7.2
		6	5	10.0	230	28	1760	28.0
			6	10.0	460	13.7	1760	13.7
			1	10.0	575	8.9	1750	8.9
7		5	15.0	230	37.3	1755	37.3	
		6	15.0	460	16.9	1755	16.9	
		1	15.0	575	12.6	1755	12.6	

For proper operation, there are three jumper wires that must remain installed and the VFD must be set to the auto mode. The 3 jumpers are shown on the unit schematic and are connected through a plug called PL25. These jumpers set the VFD to start enabled, run enabled, and tie the common bus together. The VFD has 4 LEDs on its front panel to indicate operating status. See below and VFD Troubleshooting section for details on VFD faults and alarms. The VFD faults can be reset with the VFD keypad or through the SystemVu™ controls (ALERTS/FAULT?RESET FAULT/ALERT =Yes).

The Green On LED will indicate the VFD is powered on. The Green Com. LED will flash as communication is occurring on the bus. The Yellow Warning LED will indicate when a warning is present. The Red Alarm LED will indicate when a alarm condition is present.

Refer to the VFD manufacture literature for details on using the VFD Keypad for troubleshooting.

48/50LC 07-26 VFD TROUBLESHOOTING

When communication is successful, the SystemVu control will provide alerts and faults that correlate to the VFD's warnings and alarms. Table 44 shows the list of the SystemVu controller faults and alerts and how they map to the VFD warnings and alarms. Table 44 also lists the possible causes of these cases. A VFD lockout alarm will require a power cycle to the VFD to reset. VFD warnings may reduce the actual motor speed without the SystemVu control correcting the speed. This is an acceptable action to protect the motor, and usually means there are improper configurations or motor installed.

Table 44 — 48/50LC 07-26 VFD Fault Codes

SYSTEMVU FAULT	SYSTEMVU ALERT	VFD NUMBER	VFD DESCRIPTION	VFD WARNING	VFD ALARM	TRIP LOCK	CAUSE OF PROBLEM
—	A607-IDF VFD CURRENT LIMIT	59	Current limit	X			The current is higher than the value in parameter 4-18 Current Limit.
—	A608-IDF VFD WARNING	66	Heat sink Temperature Low	X			This warning is based on the temperature sensor in the IGBT Module (Only on 400v 30 to 90 kW units).
—	A608-IDF VFD WARNING	87	Auto DC Braking	X			The drive is auto DC braking.
—	A608-IDF VFD WARNING	201	Fire Mode	X			Fire mode has been activated.
—	A608-IDF VFD WARNING	202	Fire M Limits Exceeded	X			Fire Mode has suppressed one or more warranty voiding alarms.
F610-IDF VFD PWR CARD TEMP	A605-IDF VFD THERMAL WARNING	69	Pwr Card Temperature	X	X	X	The temperature sensor on the power card is either too hot or too cold.
F611-IDF VFD EARTH FAULT	A608-IDF VFD WARNING	14	Earth fault	X	X	X	Discharge from output phases to ground.
F611-IDF VFD EARTH FAULT	—	44	Earth fault 2		X	X	Discharge from output phases to ground.
F612-IDF VFD CTL WORD LOSS	A608-IDF VFD WARNING	17	Control word timeout	X	X		No communication to variable frequency drive.
F613-IDF VFD OVER CURRENT	A607-IDF VFD CURRENT LIMIT	13	Over Current	X	X	X	Inverter peak current limit is exceeded.
F614-IDF VFD MOTOR OVER TEMP	A605-IDF VFD THERMAL WARNING	10	Motor ETR over temperature	X	X		Motor is too hot due to more than 100% load for too long. See parameter 1-90.
F615-IDF VFD OVERLOAD	A608-IDF VFD WARNING	9	Inverter overloaded	X	X		More than 100% load for too long.
F616-IDF VFD UNDER VOLTAGE	A606-IDF VFD VOLTAGE WARNING	8	DC under voltage	X	X		Intermediate circuit voltage drops below "voltage warning low" limit.
F617-IDF VFD OVER VOLTAGE	A606-IDF VFD VOLTAGE WARNING	7	DC over voltage	X	X		Intermediate circuit voltage exceeds limit.
F618-IDF VFD SHORT CIRCUIT	—	16	Short Circuit		X	X	Short-circuit in motor or on motor terminals.
F619-IDF VFD MAIN PHASE LOSS	A608-IDF VFD WARNING	4	Mains phase loss	X	X	X	Missing phase on supply side or too high voltage imbalance. Check supply voltage. See parameter 14-12.
F620-IDF VFD PHASE U LOSS	—	30	Motor phase U missing		X	X	Motor phase U is missing. Check the phase.
F621-IDF VFD PHASE V LOSS	—	31	Motor phase V missing		X	X	Motor phase V is missing. Check the phase.
F622-IDF VFD PHASE W LOSS	—	32	Motor phase W missing		X	X	Motor phase W is missing. Check the phase.
F623-IDF VFD CONTROL VOLTAGE	—	47	Control Voltage Fault		X	X	24 VDC may be overloaded.
F624-IDF VFD SUPPLY VDD	—	48	VDD1 Supply Low		X	X	Control voltage low. Please contact your local Carrier representative.
F601-IDF VFD UNEXPECTED	A605-IDF VFD THERMAL WARNING	11	Motor thermistor over temperature	X	X		Thermistor or thermistor connection is disconnected. See parameter 1-90.
F601-IDF VFD UNEXPECTED	A608-IDF VFD WARNING	2	Live zero error	X	X		Signal on terminal 53 or 54 is less than 50% of value set in parameter 6-10, 6-12, 6-20, or 6-22.

Table 44 — 48/50LC 07-26 VFD Fault Codes (cont)

SYSTEMVU FAULT	SYSTEMVU ALERT	VFD NUMBER	VFD DESCRIPTION	VFD WARNING	VFD ALARM	TRIP LOCK	CAUSE OF PROBLEM
F601-IDF VFD UNEXPECTED	A608-IDF VFD WARNING	24	Fan Fault (Only on 400V 30-90kW)	X	X		The fan is not working (Only on 400v 30 to 90 kW units).
F601-IDF VFD UNEXPECTED	A608-IDF VFD WARNING	58	AMA internal fault	X	X		Contact your local Carrier representative.
F601-IDF VFD UNEXPECTED	A608-IDF VFD WARNING	79	Illegal PS config	X	X		Internal fault. Contact your local Carrier representative.
F601-IDF VFD UNEXPECTED	A608-IDF VFD WARNING	95	Broken Belt	X	X		Torque is below the torque level set for no load, indicating a broken belt.
F601-IDF VFD UNEXPECTED	—	38	Internal fault		X	X	Contact your local Carrier representative.
F601-IDF VFD UNEXPECTED	—	50	AMA Calibration Failed		X		Contact your local Carrier representative.
F601-IDF VFD UNEXPECTED	—	51	AMA check Unom and Inom		X		The setting of motor voltage, motor current and motor power is presumably wrong. Check the settings.
F601-IDF VFD UNEXPECTED	—	52	AMA low Inom		X		The motor current is too low. Check the settings.
F601-IDF VFD UNEXPECTED	—	53	AMA motor too big		X		The motor is too big for the AMA to be carried out.
F601-IDF VFD UNEXPECTED	—	54	AMA motor too small		X		The motor is too small for the AMA to be carried out.
F601-IDF VFD UNEXPECTED	—	55	AMA Parameter out of range		X		The parameter values found from the motor are outside acceptable range.
F601-IDF VFD UNEXPECTED	—	56	AMA interrupted by user		X		The AMA has been interrupted by the user.
F601-IDF VFD UNEXPECTED	—	57	AMA timeout		X		Try to start the AMA again a number of times, until the AMA is carried out. Please note that repeated runs may heat the motor to a level where the resistance Rs and Rr are increased. In most cases, however, this is not critical.
F601-IDF VFD UNEXPECTED	—	60	External Interlock		X		External interlock has been activated. To resume normal operation, apply 24 VDC to the terminal programmed for external interlock and reset the variable frequency drive by pressing the Off/Reset button on the keypad.
F601-IDF VFD UNEXPECTED	—	80	Drive Initialized to Default Value		X		All parameter setting are initialized to default settings.
F601-IDF VFD UNEXPECTED	—	250	New spare parts		X	X	The power or switch mode power supply has been exchanged. (Only on 400v 30 to 90 kW units). Contact your local Carrier representative.
F601-IDF VFD UNEXPECTED	—	251	New Type Code		X	X	The variable frequency drive has a new type of code (Only on 400v 30 to 90 kW units). Contact your local Carrier representative.

Carrier Comfort Network® (CCN) Interface

The units can be connected to the CCN if desired. The communication bus wiring is a shielded, 3-conductor cable with drain wire and is field supplied and installed. The system elements are connected to the communication bus in a daisy chain arrangement. (See Fig. 43.) The positive pin of each system element communication connector must be wired to the positive pins of the system elements on either side of it. This is also required for the negative and signal ground pins of each system element. Wiring connections for CCN should be made at the CIB. (See Fig. 26 -29.) Consult the CCN Contractor’s Manual for further information.

NOTE: Conductors and drain wire must be 20 AWG (American Wire Gage) minimum stranded, tinned copper. Individual conductors must be insulated with PVC, PVC/nylon, vinyl, Teflon¹, or polyethylene. An aluminum/polyester 100% foil shield and an outer jacket of PVC, PVC/nylon, chrome vinyl, or Teflon with a minimum operating temperature range of -20°C to 60°C is required. See Table 45 for acceptable wiring.

1. Teflon is a registered trademark of DuPont.

Table 45 — Acceptable Wiring

MANUFACTURER	PART NUMBER
Alpha	2413 or 5463
Belden	8772
Carol	C2528
West Penn	302

It is important when connecting to a CCN communication bus that a color-coding scheme be used for the entire network to simplify the installation. It is recommended that red be used for the signal positive, black for the signal negative and white for the signal ground. Use a similar scheme for cables containing different colored wires.

At each system element, the shields of its communication bus cables must be tied together. The shield screw on CIB can be used to tie the cables together. If the communication bus is entirely within one building, the resulting continuous shield must be connected to a ground at one point only. The shield screw on CIB is not acceptable for grounding. If the communication bus cable exits from one building and enters another, the shields must be connected to grounds at the lightning

suppressor in each building where the cable enters or exits the building (one point per building only).

To connect the unit to the network:

1. Turn off power to the control box.
2. Cut the CCN wire and strip the ends of the red (+), white (ground), and black (-) conductors. (Substitute appropriate colors for different colored cables.)
3. Connect the red wire to (+) terminal on CIB, the white wire to COM terminal, and the black wire to the (-) terminal.
4. The RJ14 CCN connector on CIB can also be used, but is only intended for temporary connection (for example, a laptop computer running Carrier network software).

5. Restore power to unit.

IMPORTANT: A shorted CCN bus cable will prevent some routines from running and may prevent the unit from starting. If abnormal conditions occur, unplug the connector. If conditions return to normal, check the CCN connector and cable. Run new cable if necessary. A short in one section of the bus can cause problems with all system elements on the bus.

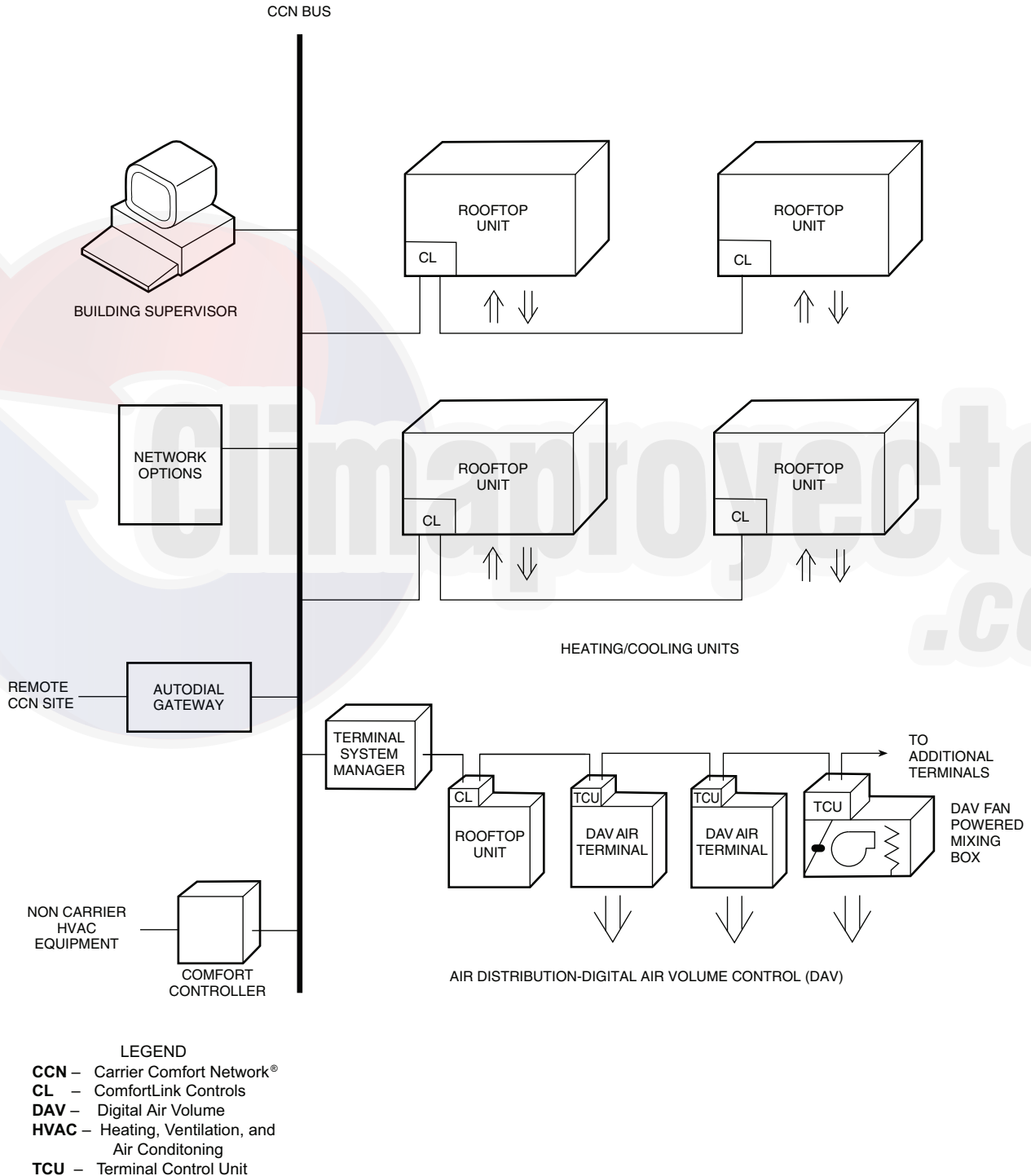

Fig. 43 — CCN System Architecture

APPENDIX A — SYSTEMVU™ CONTROLLER DISPLAY

Table A — Run Status Main Menu Layout

DISPLAY TEXT	EXPANDED TEXT	VALUES	UNITS	WRITE STATUS	POINT
SHUTDOWN UNIT?	Local Unit Shutdown Req.	Yes/No	n/a	Command	
RUN STATUS	Run Status Menu				
MODE	Mode Status Menu				
MODE	Operating Mode	see Appendix B			MODETEXT
SUB-MODE	Operating Sub-Mode	see Appendix B			SUBMTEXT
DEMAND	System Demand	see Appendix B			SYS_DMDT
LINKAGE ACTIVE	Linkage Active	Yes/No		Forcible	LNK_ACT
EFF COOL SETPOINT	Cool Setpoint In Effect	xx.x	°F		CSP_EFF
EFF HEAT SETPOINT	Heat Setpoint In Effect	xx.x	°F		HSP_EFF
DEMAND CTRL TEMP	Effective Demand Temp	xxx.x	°F		TEMP_EFF
OCC SPRH SET PT	Occupied SPRH Setpoint	0 to 100	%		SPRH_OSP
UNOCC SPRH SET PT	Unoccupied SPRH Setpoint	0 to 100	%		SPRH_USP
COOL MODE T.GUARD	Cool Mode Select T.guard	xxx	sec		COOLMSTG
HEAT MODE T.GUARD	Heat Mode Select T.guard	xxx	sec		HEATMSTG
COOLING DEMAND	Space Cooling Demand	xx.x	°F		COOL_DMD
COOL DEMAND TREND	Cooling Demand Trend	xx.x	°F/min		CLDTREND
HEATING DEMAND	Heating Space Demand	xx.x	°F		HEAT_DMD
HEAT DEMAND TREND	Heat Space Demand Trend	xx.x	°F/min		HTDTREND
DMD LIMIT STATUS	DEMAND LIMIT STATUS				
COOL DMD LIM OFF	Cool Demand Limiting	Off/On			CDMLMOFF
HEAT DMD LIM OFF	Heat Demand Limiting	Off/On			HDMLMOFF
COOL DMD LIM LEV	Cool Demand Limit Level	0 to 3			CDMDLLEV
HEAT DMD LIM LEV	Heat Demand Limit Level	0 to 3			HDMELLEV
CL DMD LIM OFFSET	Cool Demand Limit Offset	xx.x	°F		COOLDLMO
HT DMD LIM OFFSET	Heat Demand Limit Offset	xx.x	°F		HEATDLMO
COOL	Cooling Status Menu				
IDF SPEED OUTPUT	Commanded IDF Speed	0 to 100	%		FANSPEED
ACTIVE COOL STAGE	Actual Cool Stage Active	x		Forcible	ACTCSTGS
ECON CMD POSITION	Econo Commanded Position	0 to 100	%		DAMPCMD
COMMANDED ODF SPD	Commanded ODF Speed	xxxx	rpm		ODFSPD
ODF SDT SP	ODF Control SDT SP	xxxx	°F		ODFSDTSP
LA CTRL STATUS	Low Ambient Ctrl Status	0 = Normal, 1 = Entering, 2 = Low Ambient, 3 = Exiting			LACTRLST
REQ. DEHUM LEVEL	Requested Dehum Level	0 to 2			REQDHLEV
MECHANICAL COOLING	Mechanical Cooling Detail Sub-Menu				
OK TO USE COMPS?	Ok to use compressors?	Yes/No			OKMECHCL
MECH COOL ACTIVE	Mechanical Cool active?	Yes/No		Forcible	MECHCOOL
MAX COOL STAGES	Max Allowed Cool Stages	0 to 3			MAXCSTGS
REQ. COOL STAGES	Requested Cooling Stages	0 to 3			REQCSTGS
ACTIVE COOL STAGE	Actual Cool Stage Active	x			ACTCSTGS
COMMANDED ODF SPD	Commanded ODF Speed	xxxx	rpm		ODFSPD
COMP A1 TIMEGUARD	Compressor A1 Timeguard	xxx	sec		TIMGD_A1
COMP A2 TIMEGUARD	Compressor A2 Timeguard	xxx	sec		TIMGD_A2
CMP ALD TIMEGUARD	Comp A1 Loader Timeguard	xxx	sec		TIMG_ALD
SUPPLY AIR TREND	Supply Air Temp Trend	xxx.x	°F/min		SATTREND
COMP A1 STRIKES	Compressor A1 Strikes	x			A1STRIKE
COMP A2 STRIKES	Compressor A2 Strikes	x			A2STRIKE
HI PRESS OVERRIDE	High Pressure Override	Yes/No			HP_OVR
CIRCUIT A LOCKOUT	Circuit A Locked Out	Yes/No			CIRALOCK
LOW COOL LOCKOUT	Low Cooling Locked Out	Yes/No			LC_LOCK
MED COOL LOCKOUT	Medium Cooling Locked Out	Yes/No			MC_LOCK
COMP A1 AVAILABLE	Compressor A1 Available	Yes/No			CA1_AVAL
COMP A1 LOCKOUT	Compressor A1 Locked Out	Yes/No			CA1_LOCK
COMP A2 AVAILABLE	Compressor A2 Available	Yes/No			CA2_AVAL
COMP A2 LOCKOUT	Compressor A2 Locked Out	Yes/No			CA2_LOCK
FREE COOLING	Free Cooling Detail Sub-menu				
OK TO FREE COOL?	OK to Use Free Cooling?	Yes/No			OKFREECL
IN FREE COOLING	Free Cooling Active	Yes/No			FREECOOL
FREECOOL SAT SP	Free Cooling SAT Setpnt	xx.x	°F		FC_SATSP
REQ. DAMPER POS	Requested Damper Pos	0 to 100	%		REQDAMP

APPENDIX A — SYSTEMVU™ CONTROLLER DISPLAY

Table A — Run Status Main Menu Layout (cont)

DISPLAY TEXT	EXPANDED TEXT	VALUES	UNITS	WRITE STATUS	POINT
COOL (cont)					
ECON OPERATIONAL?	Econ Damper Operational	Yes/No			DAMPGOOD
DRY BULB LOCKOUT	Dry Bulb Lockout	Yes/No		Forcible	DBLOCK
ENTHALPY LOCKOUT	Enthalpy Lockout	Yes/No		Forcible	ENTHLOCK
OK TO UNOCC FC?	Ok to Unocc Free Cool?	Yes/No			OKTOUFC
IN UNOC FREECOOL?	Unocc Free Cool Active	Yes/No			UFC_ACT
UFC LOCKOUT?	Unocc Free Cool Lockout	Yes/No			UNOCLOCK
DEHUM	DEHUM				
OK TO DEHUM	Ok to Dehumidify?	Yes/No/locked out			OKTODHUM
OD TO FAN BASE DH	Ok to fan based dehum?	Yes/No			OKTOFBD
HUMIDIMIZER OK	Ok to use humidimizer?	Yes/No			OKTOHUMZ
REQ. DEHUM STGS	Req Compr Dehum Stgs	0 to 3			REQDSTGS
FBD SST LOCKOUT	FBDH SST Lockout	Yes/No			FBDSSTLO
FBD SAT LOCKOUT	FBDH SAT Lockout	Yes/No			FBDSATLO
HEAT	Heating Status Menu				
IDF SPEED OUTPUT	Commanded IDF Speed	0 to 100	%		FANSPEED
IGC FAN REQUEST	IGC Fan On Request (IFO)	On/Off			IGC_IFO
REG. HEAT STAGES	Requested Heating Stages	0 to 2			REQHSTGS
ACTIVE HEAT STAGE	Actual Heat Stage Active	x			ACTHSTGS
OK TO USE HEAT?	Ok to Run Heat?	Yes/No			OKTOHEAT
MAX HEAT STAGES	Max Allowed Heat Stages	0 to 2		Forcible	MAXHSTGS
HEAT 1 TIMEGUARD	Heat Stage 1 Timeguard	xxx	sec		TIMGD_H1
HEAT 2 TIMEGUARD	Heat Stage 2 Timeguard	xxx	sec		TIMGD_H2
SUPPLY AIR TREND	Supply Air Temp Trend	xxx.x	^F/min		SATTREND
HEAT LOCKOUT	All Heat Stages Lockout	Yes/No		Forcible	ALLHTLOC
HEAT 1 AVAILABLE	Heat Stage 1 Available	Yes/No			HT1_AVAL
HEAT 2 AVAILABLE	Heat Stage 2 Available	Yes/No			HT2_AVAL
OK TO SA TEMPER	OK to Supply Air Tempering	Yes/No			OKTOTEMP
VENTILATION	Ventilation Status Menu				
VENT MODE	Ventilation Status	see Appendix B			VENTTEXT
EFFECTIVE MIN POS	Min Position in Effect	0 to 100	%	Forcible	MIN_POS
ECON ACT POSITION	Econo Actual Position	0 to 100	%		DAMPPOS
IDF SPEED OUTPUT	Commanded IDF Speed	0 to 100	%		FANSPEED
OCCUPIED NOW	Currently Occupied	Yes/No		Forcible	OCCUPIED
IN PREOCC PURGE?	In Pre-Occupancy Purge?	Yes/No			PREOCCON
IN FREE COOLING	Free Cooling Active	Yes/No			FREECOOL
DIFF AIR QUALITY	Differential Air Quality	xxxx	ppm		AQ_DIFF
OK TO PREOC PURGE	Ok to Preoccupancy Purge	Yes/No			OKPREOCC
Override IAQ?	Is IAQ Override Active?	Yes/No	enum		IAQ_OVRD
IAQ OVRRD SW STAT	IAQ Override SW state	Yes/No	enum		IAQ_OVRS
DCV CURVE OFFSET	IAQ DCV Curve Offset	0 to 100	%		IAQ_OFFS
INDOOR FAN	Indoor Fan Status Menu				
IDF SPEED OUTPUT	Commanded IDF Speed	0 to 100	%		FANSPEED
IDF VFD FEEDBACK	IDF VFD Actual Speed %	0 to 100	%		MAV
IDF SPD OVERRIDE	IDF Speed Override Flag	On/Off	enum		FAN_OVRD
IDF ERRORS?	IDF Operation Errors?	Yes/No	enum		IDFBAD
IDF SPD REDUCTION	IDF Speed Reduction On	Yes/No	enum		FANRED10
VFD OUTPUT AMPS	IDF VFD Output Amps	xxx.xx	amps		OUTMCUR
VFD OUTPUT HP	IDF VFD Output Power HP	xxxx.x	HP		OUTPWRHP
VFD FAULT DETAIL	IDF VFD Fault Detail	0=NONE, 1=PWR CARD, 2=EARTH FLT, 3=CTRL WORD, 4=OVER CIRR, 5=OVERLOAD, 7=UNDERVOLT, 8=OVER VOLT 9=SHORT CIR, 10=PHASELOSS, 11=U LOSS, 12=V LOSS, 13=W LOSS, 14=CTRL VOLT, 15=VDD LOW, 16=MULTIPLE, 17=UNEXPECT			SVFDL

APPENDIX A — SYSTEMVU™ CONTROLLER DISPLAY

Table A — Run Status Main Menu Layout (cont)

DISPLAY TEXT	EXPANDED TEXT	VALUES	UNITS	WRITE STATUS	POINT
<i>INDOOR FAN (cont)</i>					
VFD WARN DETAIL	IDF VFD Warning Detail	0=NONE, 1=VOLTAGE, 2=CURRENT, 3=THERMAL, 4=MULTIPLE, 5=UNEXPECT			SVFDWAR
GENERAL	General Run Data Menu				
FILTER TIME LEFT	Filter hour remaining	xxxx	hours		FILTLEFT
RESET FILTER TIME	Reset Filter Timer	Yes/No	n/a	Command	RESETFLT
IN DAYLIGHT SAVE?	DST currently active	Yes/No	n/a		DST_ACTV
TCS ACTIVE?	Temp Compensate Start On	Yes/No	n/a		TCS_ACT
OCCUPANCY	OCCUPANCY DATA				
OCCUPIED NOW	Currently Occupied	Yes/No		Forcible	OCCUPIED
MINS UNTIL OCC	Mins until next occupied	xxxxx	min		MINTILOC
ACTIVE OCC CTRL	Active Occupancy control	0=24/7 OCC, 1=SCHEDULE, 2=BAS CTRL, 3=REMOC CTL, 4=TIME OVRD, 5=LINKAGE, 6=FORCED			OCC_CTRL
LINKAGE OCC REQ	Linkage Occupied Request	0=Unocc, 1=Occupied, 2=Disabled			LNK_OCC
TIMED OVRD REMAIN	Timed Override Remaining	0 to 240	min	Forcible	OVR_EXT
REMOTE OCC SWITCH	Remote Occupancy Switch	On/Off		Forcible	REMOCC
BMS OCC REQUEST	BMS Occupancy Request	0=UNOCC, 1=OCCUPIED, 2=DISABLED		Forcible	BMS_OCC
LOCAL OCC REQUEST	Local Sched Occ Request	0=Unocc, 1=Occupied		Forcible	LOC_OCC
ACTIVE PERIOD	Active Schedule period	0 to 8			PER_NO
HOLIDAY TOMORROW?	Tomorrow Is A Holiday	Yes/No			HOL_TMRW
HOLIDAY TODAY?	Today Is A Holiday	Yes/No			HOLTODAY
NEXT OCC DAY	Next Occupied Day	DDD			NXTOCDAY
NEXT OCC TIME	Next Occupied Time	hh:mm			NXTOCTIM
NEXT UNOCC DAY	Next Unoccupied Day	DDD			NXTUNDAY
NEXT UNOCC TIME	Next Unoccupied Time	hh:mm			NXTUNTIM
PREV UNOCC DAY	Previous Unoccupied Day	DDD			PRVUNDAY
PREV UNOCC TIME	Previous Unoccupied Time	hh:mm			PRVUNTIM

APPENDIX A — SYSTEMVU™ CONTROLLER DISPLAY

Table B — Settings Main Menu Layout

DISPLAY TEXT	EXPANDED TEXT	RANGE	UNITS	DEFAULT	POINT
SETTINGS	Settings Menu				
SPACE SET POINTS	Space Setpoints Adjustment Menu				
OCC COOL SETPOINT	Occupied Cool Setpoint	55 to 80	°F	78	OCSP
OCC HEAT SETPOINT	Occupied Heat Setpoint	55 to 80	°F	68	OHSP
UNOCC COOL SETPNT	Unoccupied Cool Setpoint	65 to 95	°F	85	UCSP
UNOCC HEAT SETPNT	Unoccupied Heat Setpoint	40 to 80	°F	60	UHSP
HEAT-COOL SP GAP	Heat-Cool Setpoint Gap	2 to 10	^F	5	HCSP_GAP
SPT SLIDER RANGE	SPT Offset Range (±)	0 to 5.0	°F	5	SPTO_RNG
OCC SPRH SET PT	Occupied SPRH Setpoint	0 to 100	%	55	SPRH_OSP
UNOCC SPRH SET PT	Unoccupied SPRH Setpoint	0 to 100	%	55	SPRH_USP
SA TEMPER SET PNT	SA Tempering Setpoint	xx	°F	50	SATEMPSP
TEMP DEMAND CONFIG	Temperature Demand Configuration Menu				
LOW COOL DMD ON	Low Cool Demand On	-1 to 2.0	°F	0.5	DMDLCON
MED COOL DMD ON	Medium Cool Demand On	0.5 to 20.0	°F	1	DMDMCON
HIGH COOL DMD ON	High Cool Demand On	0.5 to 20.0	°F	2	DMDHCON
LOW COOL DMD OFF	Low Cool Demand Off	-1 to 2.0	°F	-0.5	DMDLCOFF
COOL DMD LEVEL UP	Cool Demand Level Up	-2 to 2.0	^F/min	-0.2	CDMD_LUP
LOW HEAT DMD ON	Low Heat Demand On	-1 to 2.0	°F	0.5	DMDLHON
HIGH HEAT DMD ON	High Heat Demand On	0.5 to 20.0	°F	2	DMDHHON
LOW HEAT DMD OFF	Low Heat Demand Off	-1 to 2.0	°F	-0.5	DMDLHOFF
HEAT DMD LEVEL UP	Heat Demand Level Up	-2 to 2.0	^F/min	-0.2	HDMD_LUP
DEMAND TIMEGUARD1	Space Demand Time Guard1	60 to 600	sec	180	TDMD_TG1
DEMAND TIMEGUARD2	Space Demand Time Guard2	0 to 600	sec	300	TDMD_TG2
DEMAND TIMEGUARD3	Space Demand Time Guard3	5 to 120	min	10	TDMD_TG3
DMD LIMIT CONFIG	DEMAND LIMIT CONFIG				
COOL DMD LIM LEV1	Cool DMD Offset level 1	0 to 99	°F	1	CLDOLEV1
COOL DMD LIM LEV2	Cool DMD Offset level 2	0 to 99	°F	3	CLDOLEV2
COOL DMD LIM LEV3	Cool DMD Offset level 3	0 to 99	°F	5	CLDOLEV3
HEAT DMD LIM LEV1	Heat DMD Offset level 1	0 to 99	°F	1	HTDOLEV1
HEAT DMD LIM LEV2	Heat DMD Offset level 2	0 to 99	°F	3	HTDOLEV2
HEAT DMD LIM LEV3	Heat DMD Offset level 3	0 to 99	°F	5	HTDOLEV3
CLOCK	Clock Adjustment Menu				
TIME	Clock Hour and Minute	xx:xx	hh.mm		TIME
DATE	Current Date	MM/DD/YYYY			DATE
DAYLIGHT SAVINGS	Daylight Savings Configuration Menu				DST Menu
DAYLIGHT SAVINGS?	DST allowed?	Enable/Disable 1=JANUARY, 2=FEBRUARY, 3=MARCH, 4=APRIL, 5=MAY, 6=JUNE, 7=JULY, 8=AUGUST, 9=SEPTEMBER, 10=OCTOBER, 11=NOVEBER, 12=DECEMBER		Enable	DST_CFG
DST START MONTH	DST Start Month			3=MARCH	STARTM
DST START WEEK	DST Start Week	1 to 5 1=MONDAY, 2=TUESDAY, 3=WEDNESDAY, 4=THURSDAY, 5=FRIDAY, 6=SATURDAY, 7=SUNDAY		2	STARTW
DST START DAY	DST Start Day			7=SUNDAY	STARTD
DST MINS TO ADD	DST Minutes to Add	0 to 90	min	60	MINADD

APPENDIX A — SYSTEMVU™ CONTROLLER DISPLAY

Table B — Settings Main Menu Layout (cont)

DISPLAY TEXT	EXPANDED TEXT	RANGE	UNITS	DEFAULT	POINT
<i>CLOCK (cont)</i>					
DST STOP MONTH	DST Stop Month	1=JANUARY, 2=FEBRUARY, 3=MARCH, 4=APRIL, 5=MAY, 6=JUNE, 7=JULY, 8=AUGUST, 9=SEPTEMBER, 10=OCTOBER, 11=NOVEBER, 12=DECEMBER		1=JANUARY	STOPM
DST STOP WEEK	DST Stop Week	1 to 5 1=MONDAY, 2=TUESDAY, 3=WEDNESDAY, 4=THURSDAY, 5=FRIDAY, 6=SATURDAY, 7=SUNDAY		1	STOPW
DST STOP DAY	DST Stop Day			7=SUNDAY	STOPD
DST MINS TO SUB START TIME IN DAY	DST Minutes to Subtract Time in day to start DST	0 to 90 0 to 600	min min	60 120	MINSUB DST_TOD
SCHEDULES	Schedules Adjustment Menu				
SCHEDULE NUMBER	CCN Schedule Number	0 = Always Occupied, 1-64 = Local Schedule, 65-99 = Global Schedule		0=Always Occupied	SCHEDNUM
OCCUPANCY SCHEDULE HOLIDAYS ALLOW G. HOLIDAY? TIMED OVR LENGTH	OCCUPANCY SCHEDULE DATA Holiday Adjustment Menu Accept Global Holidays? Timed Override Duration	Yes/No 0 to 4		No 4	HOLIDAYT OTL_CFG
UNIT CONFIGURATIONS GENERAL	Unit Configurations Menu General Unit Configurations Menu				
STARTUP DELAY	Unit Startup Delay	10 to 600	sec	30	STARTDLY
UNIT CONTROL TYPE	Unit Control Type	0=TSTAT, 1=SPACE SEN, 2=RAT SEN 0=CONV 2C2H, 1=DIGI 2C2H, 2=CONV 3C2H, 3=DIGI 3C2H 4=DIGI 2C2H_S		0=TSTAT	CTRLTYPE
THERMOSTAT TYPE	Thermostat Hardware Type			2=CONV 3C2H	STATTYPE
ADAPTIVE TSTAT DIRTY FILTER TIME	Tstat Adaptive Staging Change Filter Timer	Yes/No 0 to 9999		Yes 600	ADPTSTAT FILTLIFE
TEST MODE TIMEOUT	Test inactivity time out	0=Disabled, 1=30 minutes, 2=1 hour, 3=2 hours, 4=4 hours, 5=8 hours, 6=12 hours		4=4 hours	TEST_ITO
CCH MAX TEMP	CCH Max Temperature	40 to 90	°F	65	CCHMAXT
STD BARO PRESSURE	Std Barometric Pressure	13.00 to 35.00	in. Hg	29.92	STD_BARP
LINK STAGEUP TIME	Linkage Stage inc. time	60 to 600	sec	180	LSTAGINC
UNIT'S MAX SAT	Unit's Maximum SAT	130 to 210	°F	200	UMAX_SAT
AUTO SAT FAULTS?	Auto Clr SAT Limit Fault	Yes/No		No	SATLACLR
ADAPTIVE TCS?	Adaptive Temp Comp Start	Enable/Disable		Enable	TCS_CFG
USER TCS BIASTIME	User TCS Start bias time	0 to 180	min	0	TCSUBIAS
SWITCH INPUTS CONFIGS	DI Config Menu				
FIRE SHUTDOWN SW	Fire Shutdown Switch	0=NORM OPEN, 1=NORM CLSD, 2=NO SWITCH		2: no FIOP 0: FIOP	FIRE_CFG
HUMSTAT CHANNEL	Humidistat Status Channel	0=None, 1=MBB DI12, 2=MBB DI13, 3=MBB DI14, 4=MBB DI02, 5=MBB DI04, 6=SI0B DI01		0=for all except Humidimizer 6=Humidimizer Units	HUMDCHAN
HUMSTAT SW TYPE	Humidistat Switch Type	0=NORM OPEN, 1=NORM CLSD		0=NORM OPEN	HUMD_CFG

APPENDIX A — SYSTEMVU™ CONTROLLER DISPLAY

Table B — Settings Main Menu Layout (cont)

DISPLAY TEXT	EXPANDED TEXT	RANGE	UNITS	DEFAULT	POINT
<i>UNIT CONFIGURATIONS (cont)</i>					
FILTER SW CHANNEL	Filter Status Sw Channel	0=None, 1=MBB DI12, 2=MBB DI13, 3=MBB DI14, 4=MBB DI02, 5=MBB DI04		0=None	FILTCHAN
FILTER SW TYPE	Filter Status Switch Type	0=NORM OPEN, 1=NORM CLSD		0=NORM OPEN	FILT_CFG
REMOTE OCC CHAN	Remote Occupancy Channel	0=None, 1=MBB DI12, 2=MBB DI13, 3=MBB DI14, 4=MBB DI02, 5=MBB DI04		0=None	RMOCCHAN
REMOTE OCC TYPE	Remote Occupancy Sw Type	0=NORM OPEN, 1=NORM CLSD		0=NORM OPEN	RMOC_CFG
REM.SHUTDOWN CHAN	Remote Shutdown Channel	0=None, 1=MBB DI12, 2=MBB DI13, 3=MBB DI14, 4=MBB DI02, 5=MBB DI04		0=None	ROFFCHAN
REM.SHUTDOWN SW T	Remote Shutdown Sw Type	0=NORM OPEN, 1=NORM CLSD		0=NORM OPEN	ROFF_CFG
REM.SHUTDOWN TYPE	Remote Shutdown ALM Type	0=Normal, 1=Emergency		0=Normal	ROFFTYPE
COFS CHANNEL	COFS Assigned Channel	0=None, 1=MBB DI12, 2=MBB DI13, 3=MBB DI14, 4=MBB DI02, 5=MBB DI04		0=None (no FIOP) 4=MBB DI02 (FIOP)	COFSCHAN
COFS TYPE	COFS Switch Type	0=NORM OPEN, 1=NORM CLSD		1=NORM CLSD	COFS_CFG
GEN STATUS CHAN	General Status Channel	0=None, 1=MBB DI12, 2=MBB DI13, 3=MBB DI14, 4=MBB DI02, 5=MBB DI04		0=None	GEN_CHAN
GEN STAT SW TYPE	General Status Sw Type	0=NORM OPEN, 1=NORM CLSD		0=NORM OPEN	GENS_CFG
SHUTDOWN GEN STAT	General Status shutdown?	Yes/No		Yes	GENFATAL
ENTHALPY SW CHAN	Enthalpy Sw Channel	0=None, 1=MBB DI12, 2=MBB DI13, 3=MBB DI14, 4=MBB DI02, 5=MBB DI04		0=None	ENTHCHAN
ENTHALPY SW TYPE	Enthalpy Switch Type	0=NORM OPEN, 1=NORM CLSD		0=NORM OPEN	ENTH_CFG
IAQ OVERRIDE SW CH	IAQ override sw channel	0=None, 1=MBB DI12, 2=MBB DI13, 3=MBB DI14, 4=MBB DI02, 5=MBB DI04, 6=SIOB DI01			IAQOCHAN
IAQ OVRRD SW TYPE	IAQ Override Switch Type	0=NORM OPEN, 1=NORM CLSD			IAQOSCFG
ANALOG INPUT CONFIGS					
SPRH SENS CHANNEL	SPRH Assigned Channel	0=None, 1=MBB AI06, 2=MBB AI07, 3=MBB AI08, 4=SIOB AI10		0=None	SPRHCHAN
SPRH RH @ 4MA	SPRH Sensor Value at 4mA	0 to 100	%	0	SPRH_4MA
SPRH RH @ 20MA	SPRH Sensor Value at 20mA	0 to 100	%	1	SPRH20MA
IAQ SENSOR CHAN	IAQ Assigned Channel	0=None, 1=MBB AI06, 2=MBB AI07, 3=MBB AI08		0: no FIOP 1: FIOP	IAQ_CHAN
IAQ PPM@ 4MA	IAQ Sensor Value at 4mA	0 to 5000	ppm	0	IAQ_4MA
IAQ PPM@ 20MA	IAQ Sensor Value at 20mA	0 to 5000	ppm	2000	IAQ_20MA

APPENDIX A — SYSTEMVU™ CONTROLLER DISPLAY

Table B — Settings Main Menu Layout (cont)

DISPLAY TEXT	EXPANDED TEXT	RANGE	UNITS	DEFAULT	POINT
<i>ANALOG INPUT CONFIGS (cont)</i>					
OAQ SENSOR CHAN	OAQ Assigned Channel	0=None, 1=MBB AI06, 2=MBB AI07, 3=MBB AI08		0=None	OAQ_CHAN
OAQ PPM@ 4MA	OAQ Sensor Value at 4mA	0 to 5000	ppm	0	OAQ_4MA
OAQ PPM@ 20MA	OAQ Sensor Value at 20mA	0 to 5000	ppm	2000	OAQ_20MA
OARH SENSOR CHAN	OARH Assigned Channel	0=None, 1=MBB AI06, 2=MBB AI07, 3=MBB AI08		0: no Enthalpy FIOF 3: Enthalpy FIOF	OARHCHAN
OARH RH @ 4MA	OARH Sensor Value at 4mA	0 to 100	%	0	OARH_4MA
OARH RH @ 20MA	OARH Sensor Val. at 20mA	0 to 100	%	100	OARH20MA
RARH SENS CHANNEL	RARH Assigned Channel	0=None, 1=MBB AI06, 2=MBB AI07, 3=MBB AI08		0=None	RARHCHAN
RARH RH @ 4MA	RARH Sensor Value at 4mA	0 to 100	%	0	RARH_4MA
RARH RH @ 20MA	RARH Sensor Value at 20mA	0 to 100	%	100	RARH20MA
OACFM SENSOR CHAN	OACFM Assigned Channel	0=None, 1=MBB AI06, 2=MBB AI07, 3=MBB AI08, 4=SI0B AI10		0=None	OCFMCHAN
OACFM@ 4MA	OACFM value at 4mA	0 to 100	CFM	0	OCFM_4MA
OACFM@ 20MA	OACFM Value at 20mA	0 to 100	CFM	20	OCFM20MA
COOLING	Cooling Configurations Menu				
LOW COOL COMP	Low Cool Compressor	1 to 2		1	LC_COMP
COMP MIN ON TIME	Compressor Min On Time	180 to 600	sec	300	C_MINON
COMP MIN OFF TIME	Compressor Min Off Time	120 to 600	sec	180	C_MINOFF
STRIKE CLEAR TIME	Runtime to Reset Strikes	120 to 999	sec	300	MIN_ON_S
COOL STAGEUP TIME	Cool Stage Increase Time	120 to 999	sec	450	CSTAGINC
COOL SATTREND LEV	Cooling SAT Trend Level	-1.0 to 1.0		-0.2	SAT_TLC
UPPER MIN SAT	Cool Min SAT Upper Level	35.0 to 65.0	°F	53 (sizes 07-12) 56 (sizes 04-06, 14-26)	SATMIN_H
LOWER MIN SAT	Cool Min SAT Lower Level	35.0 to 65.0	°F	42 (sizes 07-12) 46 (sizes 04-06, 14-26)	SATMIN_L
SPRH DEADBAND	Space RH Deadband	0	%	5	SPRH_DB
HUMZ LOCKOUT OAT	Humidimizer Lockout Temp	-20 to 75	°F	40	OATLHUMZ
HUMZ ENABLE	Humidimizer Equipped	Yes/No		No: no Humidi-Mizer FIOF Yes: Humidi-Mizer FIOF	HUMZ_EN
COOL FANOFF DELAY	Cooling Fan-off Delay	0 to 600	sec	75	COOL_FOD
FBD CONTROL TYPE	Fan Based Dehum Type	0=NONE, 1=Comfort, 2=Max		0=NONE	FBD_TYPE
FBD LOW SP	FBDH Low Set Point	-20 to 0	°F delta	-2.5	FBDLO_SP
FBD SST SETPOINT	FBDH Max Mode SST SP	20 to 60	°F	38	FBDSSTSP
FBD SST MIN VALUE	FBDH Min SST Threshold	10 to 60	°F	32	FBDH_SST
FBD COMFORT SAT	FBDH Comfort SAT SP	35 to 80	°F	46	FBDH_SAT
FBDSAT COMF DELTA	FBD Comfort SAT Delta	0 to 40	°F	11	FBDSATDT
FBD MIN IDF SPEED	Minimum IDF Speed	0 to 100	%	25	FBDMINSP
FBD MAX IDF SPEED	FBD Fan Max	0 to 100	%	100	FBDMAX
LOW AMBIENT	LOW AMBIENT CONFIGS MENU				
CIR.A LOCKOUT OAT	Circuit A Lockout Temp	-20 to 75	°F	0: no Economizer FIOF 40: Economizer FIOF	OATLCMPA
LOW AMBIENT TEMP	Low Ambient Temperature	0 to 80	°F	66	LA_TEMP
LOW COOL MIN OAT	Low Cool lockout Temp	-20 to 60	°F	10 (sizes 04-06) 30 (sizes 07-12) 40 (sizes 14-26)	LCLOCKSP
MED COOL MIN OAT	Medium Cool lockout Temp	-20 to 60	°F	20 (sizes 04-12) 30 (sizes 14-26)	MCLOCKSP
LA DEHUM LEV 1	Low Ambient Dehum Lev 1	40 to 125	°F	80	LAHTEMP1
LA DEHUM LEV 2	Low Ambient Dehum Lev 2	40 to 125	°F	61	LAHTEMP2

APPENDIX A — SYSTEMVU™ CONTROLLER DISPLAY

Table B — Settings Main Menu Layout (cont)

DISPLAY TEXT	EXPANDED TEXT	RANGE	UNITS	DEFAULT	POINT
<i>COOLING (cont)</i>					
LA DEHUM LEV 3	Low Ambient Dehum Lev 3	40 to 125	°F	55	LAHTEMP3
LA DEHUM SDT SP 1	LA Dehum SDT SP Lev 1	60 to 120	°F	93	LHSDTSP1
LA DEHUM SDT SP 2	LA Dehum SDT SP Lev 2	60 to 120	°F	93	LHSDTSP2
LA DEHUM SDT SP 3	LA Dehum SDT SP Lev 3	60 to 120	°F	104	LHSDTSP3
CHARGE DIAGNOSTICS	Refrigerant Charge Diagnostic Config Menu				
LOW CHARGE LEVEL	Low Refrig Charge Level	0 to 150	psi	50	LOCHARGE
NO LOW CHARGE OAT	Low Charge Disable Temp	-40 to 50	°F	10	LOCH_LOT
CIR.A SDP LIMIT	CirA High Pressure Limit	400 to 700	psi	600	HIPLIM_A
LOW DISCHARGE LEV	Low Discharge Level	0 to 20	°F	0	SDTLEV
MIN PRESS RATIO	Minimum Pressure Ratio	0 to 5		1.35	MINPSI_R
LOW SUCTION DIAG.	Low Suction Diagnostic Config Menu				
LOW SUC OK TEMP	Suction OK Temperature	10 to 50	°F	18	SSTOK
LOW SUC LEVEL 1	Low Suction Level 1 Temp	10 to 50	°F	20	SSTLEV1
LOW SUC LEVEL 2	Low Suction Level 2 Temp	5 to 50	°F	15	SSTLEV2
LOW SUC LEVEL 3	Low Suction Level 3 Temp	0 to 50	°F	10	SSTLEV3
LO SUC DIAG DELAY	Delay On Low SST Check	0 to 300	sec	0	SSTCKDLY
COMPRESSOR TRANSITION	Compressor Transition diagnostic config menu				
COMP L2 DIAG DLY	Comp level 2 Diag Delay	1 to 99	sec	15 (sizes 04-12) 40 (sizes 14-26)	CDDTLEV2
IAG. COMP OFF	Diag Comp Unexpected Off	Enable/Disable		Enabled	CD_UEOFF
CIR STUCK ON DIAG	Circuit Stuck On Diag.	Enable/Disable		Enabled	DCKTOFF
CIR.A MIN DIS.P	Min discharge change	0 to 99	psi	11 (sizes 04-12) 17 (sizes 14-26)	MDP_DISA
CIR.A MIN SUC.P	Min Suction change	0 to 99	psi	4 (sizes 04-06) 6.5 (size 07) 8 (size 08) 7 (sizes 09-12) 14 (sizes 14-26)	MDP_SUCA
OFF P.RATIO	CirA P.Ratio off change	-1 to 1		-0.2 (sizes 07, 09-14) -0.3 (sizes 08, 17-26)	OFFPR_A
ODF SETTINGS	Outdoor Fans Configurations Menu				
ODF SIGNAL QTY	Number of ODF Outputs	0 to 3		1 (sizes 04-06) 2 (sizes 07, 17, or 20) 3 (sizes 08-14, 24-26)	NUM_ODF
ODF LOW COOL SPD	ODF Low Cool Speed	0 to 1200	rpm	1000 (size 04) 1075 (sizes 05-06) 550 (sizes 07-12) 700 (sizes 14-17, 26) 650 (sizes 20-24)	ODFLCSPD
ODF MED COOL SPD	ODF Med Cool Speed	0 to 1200	rpm	1000 (size 04) 1075 (sizes 05-06) 700 (sizes 07, 12, or 24) 600 (size 08) 650 (size 09) 800 (sizes 14, 17, or 26) 750 (size 20)	ODFMCSPD
ODF HIGH COOL SPD	ODF High Cool Speed	0 to 1200	rpm	1000 (size 04) 1075 (sizes 05-06) 950 (sizes 07 or 09) 900 (size 08) 1000 (sizes 12-26)	ODFHCSPP
ODF MAXIMUM SPEED	ODF Maximum Speed	0 to 1200	rpm	1000 (size 04) 1075 (sizes 05-06) 950 (sizes 07 or 09) 900 (size 08) 1000 (sizes 12-26)	ODFMAXSP
ODF MINIMUM SPEED	ODF Minimum Speed	0 to 1200	rpm	160	ODFMINSPP

APPENDIX A — SYSTEMVU™ CONTROLLER DISPLAY

Table B — Settings Main Menu Layout (cont)

DISPLAY TEXT	EXPANDED TEXT	RANGE	UNITS	DEFAULT	POINT
HEATING	Heating Configurations Menu				
UNIT TYPE OF HEAT	Type of Heat Installed	0=ELECTRIC, 1=GAS		0 (50 series) 1 (48 series) 2 (all except below); 0 (50 series without FIOP heat), 1 (50 Series, sizes 04- 06 low or medium heat), 1 (50 series, sizes 07-14 and low heat), 1 (50 series, sizes 07- 12 and medium heat)	HEATTYPE
HEATING STAGE QTY	Number of Heating Stages	0 to 2			NUMHSTGS
HEAT MIN ON	Heat Minimum On Time	60 to 600	sec	120	H_MINON
HEAT MIN OFF	Heat Minimum Off Time	60 to 600	sec	120	H_MINOFF
HEAT STAGEUP TIME	Heat Stage Increase Time	120 to 999	sec	450	HSTAGINC
HEAT SATTREND LEV	Heating SAT Trend Level	-1 to 1.0	^F/min	0.2	SAT_TLH
LOWER MAX SAT	Heat Max SAT Lower Level	85.0 to 200.0	°F	140	SATMAX_L
UPPER MAX SAT	Heat Max SAT Upper Level	85.0 to 200.0	°F	160	SATMAX_H
HEAT FANOFF DELAY	Heating Fan-off Delay	10 to 600	sec	30 (50 series) 45 (48 series)	HEAT_FOD
HEAT LOCKOUT OAT	Heating Lockout Temp	40 to 125	°F	75	OATLHEAT
SAT DURING HEAT?	SAT Heat Mode Sensing	Enable/Disable		Enable	SAT_HEAT
IGC IFO TIMEOUT	No IGC IFO input Timeout	0 to 60	min	5	NO_IGCTM
PREHEAT W/O IDF?	Pre-Heat HX without IDF?	Enable/Disable		Disable	PREHT_HX
PREHEAT FAN DELAY	Pre-Heat Fan On Delay	0 to 120	sec	30	PREHT_TM
SA TEMPER ENABLED	Supply Air Tempering Enable	Yes/No		Yes	SATEMPEN
SA TEMPER SET PNT	SA tempering Setpoint	xx	°F	50	SATEMPSP
TEMPER MAX OUT	Max OAT for SA tempering	-40 to 125	°F	48	OATSTEMP
INDOOR FAN	Indoor Fan Configurations Menu				
INDOOR FAN TYPE	Indoor Fan Type	0=None, 1=VFD, 2=DIRECT DRIVE		1=VFD: all except Direct Drive motor Option 2 = DIRECT DRIVE: on 04-06 size with direct drive motors	IDFTYPE
DIR.DRV IDF SPDS OCCUPIED FAN?	Number Of Fan Speeds Fan On When Occupied	2 to 3 Yes/No		2 Yes	NUMFSPDS FANON_OC
MAXIMUM IDF SPEED	IDF Maximum Fan Speed	80 to 100	%	100	SPEEDMAX
VENT IDF SPEED	Ventilation Only IDF Spd	0 to 100	%	50 (sizes 04-06) 67 (sizes 07-12) 53 (sizes 14 or 20) 56 (sizes 17) 52 (sizes 24) 60 (sizes 26)	FSPDVENT
HEATING IDF SPD	Heating IDF Speed	20-100	%	100	FSPD_HT
FREE COOL IDF SPD	Free Cooling IDF Speed	0-100	%	70 (size 04) 57 (sizes 05-06) 67 (sizes 07-12) 53 (sizes 14 or 20) 56 (sizes 17) 52 (sizes 24) 60 (sizes 26)	FSPD_FCL
LOW COOL IDF SPD	Low Cooling IDF Speed	20-100	%	70 (size 04) 57 (sizes 05-06) 67 (sizes 07-12) 53 (sizes 14 or 20) 56 (sizes 17) 52 (sizes 24) 60 (sizes 26)	FSPD_LCL
MED COOL IDF SPD	Med Cooling IDF Speed	20-100	%	87 (sizes 04) 71 (sizes 05) 69 (sizes 06) 67 (sizes 07-12) 79 (sizes 14) 82 (sizes 17) 62 (sizes 20) 65 (sizes 24) 72 (sizes 26)	FSPD_MCL
HIGH COOL IDF SPD	High Cooling IDF Speed	20-100	%	100	FSPD_HCL
SHUTDOWN IDF FAIL	Shut Down on IDF Failure	Yes/No		Yes	FATALFAN
SHUTDOWN VFD HAND	VFD Hand Mode Shutdown?	Yes/No		Yes	HANDSHUT

APPENDIX A — SYSTEMVU™ CONTROLLER DISPLAY

Table B — Settings Main Menu Layout (cont)

DISPLAY TEXT	EXPANDED TEXT	RANGE	UNITS	DEFAULT	POINT
<i>INDOOR FAN (cont)</i>					
VFD IN REVERSE?	IDF VFD Motor In Reverse	Yes/No		No (sizes 04-12) Yes (sizes 14-26)	VFD1MDIR
IDF VFD PARAMETERS	Indoor Fan VFD Settings Menu				
IDF VFD NOM. HP	IDF VFD Motor HP	1 to 26	HP	See VFD Motor Default Configuration Tables. Table 35 (sizes 04-06) Table 42 (Vert. sizes 07-26) Table 43 (Horz. Sizes 14-26)	MOTPWRHP
IDF VFD VOLTAGE	IDF VFD Motor Volts	50 to 1000	V	See VFD Motor Default Configuration Tables. Table 35 (sizes 04-06) Table 42 (Vert. sizes 07-26) Table 43 (Horz. Sizes 14-26)	MOTVOLT
IDF VFD NOM. FREQ	IDF VFD Motor Freq.	20 to 400	Hz	60	MOTFREQ
IDF VFD NOM. AMPS	IDF VFD Motor Current	0.1 to 40	A	See VFD Motor Default Configuration Tables. Table 35 (sizes 04-06) Table 42 (Vert. sizes 07-26) Table 43 (Horz. Sizes 14-26)	MOTCUR
IDF VFD NOM. RPM	IDF VFD Motor Nom. RPM	100 to 60000	rpm	See VFD Motor Default Configuration Tables. Table 35 (sizes 04-06) Table 42 (Vert. sizes 07-26) Table 43 (Horz. Sizes 14-26)	MOTNOMSP
IDF VFD MIN REF	IDF Danfoss Min Ref	0 to 65	Hz	0	MINREF
IDF VFD MAX REF	IDF Danfoss Max Ref	0 to 65	Hz	60	MAXREF
VFD ACCEL. TIME	IDF VFD Accel. Time	1 to 1800	sec	10	RAMPUP_T
VFD DECEL. TIME	IDF VFD Decel. Time	1 to 1800	sec	10	RAMPDN_T
IDF VFD MAX AMPS	IDF VFD Max Current	0 to 655.35	A	See VFD Motor Default Configuration Tables. Table 35 (sizes 04-06) Table 42 (Vert. sizes 07-26) Table 43 (Horz. Sizes 14-26)	VFD1MAXA
IDF VFD TIMEOUT	IDF Danfoss Comm. TO	1 to 600	sec	30	CNT_TOUT
IDF VFD RESET DUR	IDF Danfoss Auto Reset	0 to 600	sec	30	ARSTRT_T
VFD RFI FILTER	IDF Danfoss RFI Filter	On/Off		On	RFIFILTR
ECONOMIZER					
ECON INSTALLED?	Economizer Configurations Menu	Yes/No		No: no FIOP Yes: FIOP	ECONO
ECON MAX POS	Econ Max Damper Position	0 to 100	%	100	DAMPMAX
ECON TRAVEL TIME	Economizer Travel Time	5 to 300	sec	150	ECONOTRV
MINIMUM POSITION CONFIGS	Minimum Position Configurations Menu				
MIN POS@ MAX FAN	Econ Min at Max Fan Speed	0 to 100	%	30	MINP_MAX
MIN POS SPEED 1	Min Pos – User Speed 1	0 to 100	%	0	MP_USPD1
MIN POS DAMP 1	Min Pos – User Pos 1	0 to 100	%	0	MP_UPOS1
MIN POS SPEED 2	Min Pos – User Speed 2	0 to 100	%	0	MP_USPD2
MIN POS DAMP 2	Min Pos – User Pos 2	0 to 100	%	0	MP_UPOS2
MIN POS SPEED 3	Min Pos – User Speed 3	0 to 100	%	0	MP_USPD3
MIN POS DAMP 3	Min Pos – User Pos 3	0 to 100	%	0	MP_UPOS3
FREE COOL CONFIGS	Free Cooling Specific Configurations Menu				
LOW COOL SAT SP	Low Free Cool SAT Setpnt	40 to 80	°F	65	LCSASP
HIGH COOL SAT SP	High Free Cool SAT Setpnt	40 to 80	°F	55	HCSASP
FREE COOL MAX OAT	Free Cooling Max OAT	0 to 90	°F	65	MAXFREET
FREE COOL MIN OAT	Free Cooling Min Temp	-30 to 70	°F	0	MINFREET

APPENDIX A — SYSTEMVU™ CONTROLLER DISPLAY

Table B — Settings Main Menu Layout (cont)

DISPLAY TEXT	EXPANDED TEXT	RANGE	UNITS	DEFAULT	POINT
<i>ECONOMIZER (cont)</i>					
DIFF DRY BULB CTL	Diff. Dry Bulb Control	Enable/Disable		Disable	DIFFBULB
DIFF DB DEADBAND	Diff. Dry Bulb Deadband	0 to 20	°F	3	OATRATDB
ENTHALPY HI LIMIT	Max Enthalpy OA Limit	1.0 to 99.0	Btu/lb	28	FREEMAXE
DIFF ENTHALPY CTL	Diff. Enthalpy Control	Enable/Disable		Disable	DIFFENTH
ENTHALPY DEADBAND	Enthalpy Cross Deadband	0 to 20.0	Btu/lb	2	OAERAEDB
UNOCCUPIED FREE COOL	Unoccupied Free Cooling Configs Menu				
WHEN TO UNOCC FC	When to Unocc Free Cool?	0=Disabled, 1=PreOcc, 2=Unocc		1=PreOcc	UFC_CFG
UFC PREOCC TIME	UFC PreOcc Time	1 to 999	min	120	UFCTIME
UFC LOW TEMP	Unocc Free Cool Low Temp	-30 to 70	°F	50	OATLUFC
POWER EXHAUST CONFIGS	Power Exhaust Configurations Menu				
PE1 RELAY CHANNEL	PE1 Relay Channel	0=NONE, 1=MBB RLY11, 2=MBB RLY06		0: no FIOP 2: FIOP	PE1_CHAN
PE1 POS@ MAX SPD	PE Stage 1 at Max speed	0 to 100	%	40	PE1_PMAX
PE OFF DEADBAND	PE Turn Off Deadband	0 to 100	%	5	PE_OFFDB
PE2 RELAY CHANNEL	PE2 Relay Channel	0=NONE, 1=MBB RLY11, 2=MBB RLY06		0=None	PE2_CHAN
PE2 POS@ MAX SPD	PE Stage 2 at max speed	0 to 100	%	75	PE2_PMAX
ECON ACT MECH DISC DIAG	Econ Actuator Mechanical disconnect diagnostic menu				
MDD-H/C END DLY	T24 Heat/Cool End Delay	0 to 60	min	25	T24CHDLY
MDD- MIN MOVE	T24 Econ Min Move for SAT	10 to 20	%	10	T24ECSTS
MDD-SAT DB	Damper SAT deadband	0 to 20.0	°F	12	T24SATDB
MDD-MIN RAT-OAT	T24 Min Diff in RAT-OAT	5.0 to 20.0	°F	15	T24RATDF
MDD-MIN TEST POS	T24 Test Minimum Pos	0 to 100	%	15	T24TSTMN
MDD-MAX TEST POS	T24 Test Maximum Pos	0 to 100	%	85	T24TSTMX
AIR QUALITY	Air Quality Configurations Menu				
ANALOG IAQ CTRL	Analog Input IAQ Control	0=NO IAQ, 1=DCV, 2=IAQ OVRD, 3=CTRL MINP		0: no FIOP 1: FIOP	IAQANCFG
IAQ POS@ MAX SPD	IAQ Position at Max Fan	0 to 100	%	10	IAQMINP
LOW AIR.Q DIFF	AQ Differential Low	0 to 5000	ppm	100	DAQ_LOW
HIGH AIR.Q DIFF	AQ Differential High	0 to 5000	ppm	700	DAQ_HIGH
PREOCC PURGE ENBL	IAQ Preoccupancy Purge	Yes/No		Yes	IAQPURGE
PURGE POS@ MAX	IAQ Purge Pos at Max IDF	0 to 100	%	40	IAQPMAX
PREOCC LOW LIMIT	Preocc Purge Lockout OAT	0 to 70	°F	50	IAQP_LA
PREOCC PURGE TIME	Preocc Purge Duration	5 to 120	min	15	IAQPTIME
AQ DIF HI-IAQ OVR	AQ Diff High IAQOVERRIDE	0 to 5000	ppm	700	AQD_HIGH
AQ DIF LO-IAQ OVR	AQ Diff Low- IAQ OVERRIDE	0 to 5000	ppm	100	AQD_LOW
IAQ OVRRD ENABLE	IAQ Override Enable	Yes/No	enum	No	IAQOVREN
ALARM RELAY	Alarm Relay Configurations Menu				
ALM RELAY CHANNEL	ALM Relay Assigned Chan	0=NONE, 1=MBB RLY11, 2=MBB RLY06		1=MBB RLY11	ALM_CHAN
THERMOSTAT ALERTS	Thermostat Alerts	Yes/No		Yes	TSTAT_AL
HARDWARE ALERTS	Hardware Failures Alerts	Yes/No		Yes	HW_AL
SAT/RAT ALERTS	SAT/RAT Sensor Alerts	Yes/No		Yes	SATRATAL
OAT SENSOR ALERTS	OAT Thermistor Alerts	Yes/No		Yes	OATRL_AL
SPACE SENS ALERTS	Space Sensors Alerts	Yes/No		Yes	SPACE_AL
TRANSDUCER ALERTS	Transducer Sensor Alerts	Yes/No		Yes	TRANS_AL
RH SENSOR ALERTS	RH Sensor Failure Alerts	Yes/No		Yes	RHS_AL
CO2 SENSOR ALERTS	Air Quality CO ₂ Alerts	Yes/No		Yes	CO2S_AL
OACFM SENS ALERTS	OACFM Alarm Relay	Yes/No		Yes	OACFM_AL
ECONOMIZER ALERTS	Economizer Alerts	Yes/No		Yes	ECON_AL
AIR FILTER ALERTS	Dirty Filter Alerts	Yes/No		Yes	FILT_AL
GEN STATUS ALERTS	General Status Alerts	Yes/No		Yes	GENS_AL
REFRIG CIR ALERTS	Refrig Circuit Alerts	Yes/No		Yes	CKT_AL
COMPRESSOR ALERTS	Compressor Alerts	Yes/No		Yes	COMP_AL

APPENDIX A — SYSTEMVU™ CONTROLLER DISPLAY

Table B — Settings Main Menu Layout (cont)

DISPLAY TEXT	EXPANDED TEXT	RANGE	UNITS	DEFAULT	POINT
<i>ALARM RELAY (cont)</i>					
HEATING ALERTS	Heating Failure Alerts	Yes/No		Yes	HEAT_AL
INDOOR FAN ALERTS	Indoor Fan Alerts	Yes/No		Yes	FAN_AL
VFD ALERTS	VFD Alerts	Yes/No		Yes	VFD_AL
IO BOARD ALERTS	Relay On Active IOBA	Yes/No		No	IOBFA_AL
ON ACTIVE FAULTS	Relay on Active Faults	Yes/No		Yes	FAULT_AL
SERVICE CONFIG MENU					
	Service Configuration Menu				
CMP FRAMEWORK	Compressor Framework	0=1CIR 2CMP, 1=1CMP+LDR, 2=1CMP		0 (sizes 07-26) 1 (sizes 04-06)	SYSVTYPE
SHUTDOWN A1 FIRST	Comp A1 Shutdown First	Yes/No		Yes (sizes 07-26) No (sizes 04-06)	SDWN_A1
SHUTDOWN ALD FIRST	Comp Loader Shutdown 1st	Yes/No		No (sizes 07-26) Yes (sizes 04-06)	SDWN_ALD
SIOB1 INSTALLED	SIOB 1 Enabled	Yes/No		No: no Humidi-Mizer FIOP Yes: Humidi-Mizer FIOP	SIOB1_EN
ECONO PID - KP	ECONO PID - KP	0.00 to 99.90		2.5	ECONO_P
ECONO PID - KI	ECONO PID - KI	0.00 to 99.90		0.12	ECONO_I
ECONO PID - KD	ECONO PID - KD	0.00 to 99.90		1	ECONO_D
ECONO PID - RATE	ECONO PID - RATE	10 to 180	sec	15	ECONO_DT
FBD PID Kp	FBD PID Kp	0 to 99.99999		0.01	FBDPID_P
FBD PID Ki	FBD PID Ki	0 to 99.99999		0	FBDPID_I
FBD PID Kd	FBD PID Kd	0 to 99.99999		0	FBDPID_D
FBD KI RESET VAL	FBD Ki Reset Val.	0 to 99.9		0	FBDKIRES
ODF ADVANCED CONFIGS	Outdoor Fan Advanced Configs Menu				
ODF GAIN	ODF Gain	-100 to 100		1 (sizes 07) 2 (sizes 08-12) 1.8 (sizes 14-20) 1.4 (sizes 04-06, 24-26)	ODF_KC
ODF ANTI-WINDUP	ODF anti-windup factor	-100 to 100		0.6	ODF_NI
ODF INTEGRAL TIME	ODF Integral Time	-100 to 100		20 (sizes 04-12) 40 (sizes 14-26)	ODF_TI
ODF MBIAS 1	ODF Map Bias Term 1	-200 to 200		66.7 (sizes 07) -44.55 (sizes 08-12) 10 (sizes 14-20) 72.5 (sizes 04-06, 24-26)	ODFBIAS1
ODF MBIAS 2	ODF Map Bias Term 2	-200 to 200		95.2 (sizes 07) 80.59 (sizes 08-12) 35.3 (sizes 14-20) 100.98 (sizes 04-06, 24-26)	ODFBIAS2
ODF MBIAS 3	ODF Map Bias Term 3	-200 to 200		0 (sizes 07, 14-20) 20.93 (sizes 04-06) 65.29 (sizes 08-12) 114.74 (sizes 24-26)	ODFBIAS3
ODF SWITCH POINT1	ODF Fans Switch Point 1	-100 to 100		3.68 (sizes 07) 3.4 (sizes 08-12) 4.84 (sizes 14-20) 1.58 (sizes 04-06, 24-26)	ODFPIUP1
ODF SWITCH POINT2	ODF Fans Switch Point 2	-100 to 100		17.1 (sizes 07) 9.06 (sizes 08-12) 22.3 (sizes 14-20) 10.44 (sizes 04-06, 24-26)	ODFPIUP2
ODF SWITCH POINT3	ODF Fans Switch Point 3	-100 to 100		100 (sizes 07, 14-20) 19.76 (sizes 08-12) 20.93 (sizes 04-06, 24-26)	ODFPIUP3
ODF PROP PR	ODF Proportional ctrl Pr	-100 to 100		25 (sizes 07-12) 50 (sizes 04-06, 14-26)	ODFPR_KC
ODF MSLOPE 1	ODF Map Slope Term 1	-100 to 100		25.3 (sizes 07) 60.09 (sizes 08-12) 31 (sizes 14-20) 55.33 (sizes 04-06, 24-26)	ODFSLPE1

APPENDIX A — SYSTEMVU™ CONTROLLER DISPLAY

Table B — Settings Main Menu Layout (cont)

DISPLAY TEXT	EXPANDED TEXT	RANGE	UNITS	DEFAULT	POINT
<i>SERVICE CONFIG MENU (cont)</i>					
ODF MSLOPE 2	ODF Map Slope Term 2	-100 to 100		9 (sizes 07) 18.69 (sizes 08-12) 9.6 (sizes 14-20) 19.07 (sizes 04-06, 24-26)	ODFSLPE2
ODF MSLOPE 3	ODF Map Slope Term 3	-100 to 100		1 (sizes 07, 14-20) 9.34 (sizes 08-12) 8.85 (sizes 04-06, 24- 26)	ODFSLPE3
NEW HARDWARE					
UNIT CONTROL TYPE	Unit Control Type	0=TSTAT, 1=SPACE SEN, 2=RAT SEN		0=TSTAT	CTRLTYPE
ECON INSTALLED?	Economizer Installed?	Yes/No		No: no FIOP Yes: FIOP	ECONO
SPRH SENS CHANNEL	SPRH Assigned Channel	0=None, 1=MBB A106, 2=MBB A107, 3=MBB A108, 4=SIOB Ai10		0=None	SPRHCHAN
IAQ SENSOR CHAN	IAQ Assigned Channel	0=None, 1=MBB A106, 2=MBB A107, 3=MBB A108		1: no FIOP 0: FIOP	IAQ_CHAN
OAQ SENSOR CHAN	OAQ Assigned Channel	0=None, 1=MBB A106, 2=MBB A107, 3=MBB A108		0=None	OAQ_CHAN
OARH SENSOR CHAN	OARH Assigned Channel	0=None, 1=MBB A106, 2=MBB A107, 3=MBB A108		3: no FIOP 0: FIOP	OARHCHAN
RARH SENS CHANNEL	RARH Assigned Channel	0=None, 1=MBB A106, 2=MBB A107, 3=MBB A108		0=None	RARHCHAN
OACFM SENS CHANNEL	OACFM Assigned Channel	0=None, 1=MBB A106, 2=MBB A107, 3=MBB A108, 4=SIOB Ai10		0=None	OCFMCHAN
FIRE SHUTDOWN SW	Fire Shutdown Switch	0=NORM OPEN, 1=NORM CLSD, 2=NO SWITCH		2: no FIOP 0: FIOP	FIRE_CFG
FILTER SW CHANNEL	Filter Status Sw Channel	0=None, 1=MBB DI12, 2=MBB DI13, 3=MBB DI14, 4=MBB DI02, 5=MBB DI04		0=None	FILTCHAN
REMOTE OCC CHAN	Remote Occupancy Channel	0=None, 1=MBB DI12, 2=MBB DI13, 3=MBB DI14, 4=MBB DI02, 5=MBB DI04		0=None	RMOCCCHAN
REM.SHUTDOWN CHAN	Remote Shutdown Channel	0=None, 1=MBB DI12, 2=MBB DI13, 3=MBB DI14, 4=MBB DI02, 5=MBB DI04		0=None	ROFFCHAN
COFS CHANNEL	COFS Assigned Channel	0=None, 1=MBB DI12, 2=MBB DI13, 3=MBB DI14, 4=MBB DI02, 5=MBB DI04		0=None	COFSCHAN
GEN STATUS CHAN	General Status Channel	0=None, 1=MBB DI12, 2=MBB DI13, 3=MBB DI14, 4=MBB DI02, 5=MBB DI04		0=None	GEN_CHAN

APPENDIX A — SYSTEMVU™ CONTROLLER DISPLAY

Table B — Settings Main Menu Layout (cont)

DISPLAY TEXT	EXPANDED TEXT	RANGE	UNITS	DEFAULT	POINT
<i>NEW HARDWARE (cont)</i>					
ENTHALPY SW CHAN	Enthalpy Sw Channel	0=None, 1=MBB DI12, 2=MBB DI13, 3=MBB DI14, 4=MBB DI02, 5=MBB DI04		0=None	ENTHCHAN
NETWORK SETTINGS	Building Network Configurations Menu				
BAS PROTOCOL	BAS Protocol Select	0=NONE, 1=CCN, 2=BACNET	x	0=NONE	BMS_CFG
NETWORK TIMEOUT	Network Input Timeout	0 to 600	min	30	NETINTO
CCN	CCN Network Configuration Menu				
BUS NUMBER	CCN Bus Number	0 to 239		0	CCNBUS
CCN ELEMENT #	CCN Element Number	1 to 239		1	CCNADD
CCN BAUDRATE	CCN Baud Rate	0=9600, 1=19200, 2=38400		2=38400	BAUDENUM
BROADCAST ACK?	CCN Broadcast Ack'er	Yes/No		No	CCNBCACK
BROADCAST SCHEDL?	Global Schedule Broadcast	Yes/No		No	CCN_GSBC
BROADCAST TIME?	CCN Time Broadcast	Yes/No		No	CCNBC
BROADCAST OAT?	Broadcast OAT On Network	Yes/No		No	OATBC
BROADCAST OARH?	Broadcast OARH On Network	Yes/No		No	OARHBC
BROADCAST OAQ?	Broadcast OAQ On Network	Yes/No		No	OAQBC
BROADCAST IAQ?	Broadcast IAQ On Network	Yes/No		No	IAQBC
LOCATION	Device Location	text string		<blank>	DEV_LOC
REFERENCE NUMBER	Reference number	text string		<blank>	REF_NUM
BACNET	BACnet network configuration menu				
MAC ADDRESS	BACnet Device Macaddress	1 to 127		01	BAC_MAC
BACNET BAUDRATE	BACnet BMS baud rate	0=9600, 1=19200, 2=38400, 3=57600, 4=76800, 5=115200		4=76800	BAC_BAUD
AUTO ID SCHEME	ALC Auto ID Scheme	Yes/No		Yes	AUID
BACNET AUTO ID	BACnet ID Auto ID	Yes/No		Yes	BAC_AUID
BACNET ID	BACnet ID Number	0 to 4194302		1610101	BAC_ID
LINKAGE SETTINGS	LINKAGE SETTINGS MENU				
DEVICE IAQ	BACnet device for IAQ	0 to 4194303		1610100	DEVIAQ
OBJECT ID IAQ	Object instance for IAQ	0 to 9999		1009	OBJIAQ
COV IAQ	Change of value for IAQ	0 to 60		0	COVIAQ
DEVICE OAQ	BACnet device for OAQ	0 to 4194303		1610100	DEVOAQ
OBJECT ID OAQ	Object instance for OAQ	0 to 9999		285	OBJOAQ
COV OAQ	Change of value for OAQ	0 to 60		0	COVOAQ
DEVICE OARH	BACnet device for OARH	0 to 4194303		1610100	DEVOARH
OBJECT ID OARH	Object instance for OARH	0 to 9999		1022	OBJOARH
COV OARH	Change of value for OARH	0 to 60		0	COVOARH
DEVICE OAT	BACnet device for OAT	0 to 4194303		1610100	DEVOAT
OBJECT ID OAT	Object instance for OAT	0 to 9999		1003	OBJOAT
COV OAT	Change of value for OAT	0 to 60		0	COVOAT
DEVICE RARH	BACnet device for RARH	0 to 4194303		1610100	DEVRARH
OBJECT ID RARH	Object instance for RARH	0 to 9999		30	OBJRARH
COV RARH	Change of value for RARH	0 to 60		0	COVRARH
DEVICE RAT	BACnet device for RAT	0 to 4194303		1610100	DEVSTAT
OBJECT ID RAT	Object instance for RAT	0 to 9999		1010	OBJRAT
COV RAT	Change of value for RAT	0 to 60		0	COVRAT
DEVICE SPT	BACnet device for SPT	0 to 4194303		1610100	DEVSPT
OBJECT ID SPT	Object instance for SPT	0 to 9999		2007	OBJSPT
COV SPT	Change of value for SPT	0 to 60		0	COVSPT
LOCAL_SHEDL_EDIT	Allow Local Sched Edit	Yes/No	enum	No	LCL_EDIT
SYSTEM TOUCH	System Touch Menu				
DEVICE INSTANCE	System Touch Device Inst	0 to 4194303		160099	DEVST
POLLING RATE	System Touch Poll Rate	10 to 60		10	POLLST

APPENDIX A — SYSTEMVU™ CONTROLLER DISPLAY

Table B — Settings Main Menu Layout (cont)

DISPLAY TEXT	EXPANDED TEXT	RANGE	UNITS	DEFAULT	POINT
<i>NETWORK SETTINGS (cont)</i>					
SPACE TEMP AI	System Touch AI for SPT	0 to 9999		1	AISTSP
SPACE RH AI	System Touch AI for SPRH	0 to 9999		4	AISTSPRH
ZS SENSOR CFG	ZS Sensor Configuration				
ZS1 ADDRESS	Zone Sensor 1 Address	0 to 255		255	ZSADDR1
ZS2 ADDRESS	Zone Sensor 2 Address	0 to 255		255	ZSADDR2
ZS3 ADDRESS	Zone Sensor 3 Address	0 to 255		255	ZSADDR3
ZS4 ADDRESS	Zone Sensor 4 Address	0 to 255		255	ZSADDR4
ZS5 ADDRESS	Zone Sensor 5 Address	0 to 255		255	ZSADDR5
ZS POLL RATE	Zone Sensor Poll Rate	1 to 100	sec	5	ZSPOLLRT
ZS UNIT	Zone Sensor Unit	0=degrees F		0=degrees F	ZSUNIT
ZS FRC UNOC ENBL	ZS Force Unoccup Enable	No		No	ZSFUNEN
ZS FRC UNOC DELAY	ZS Force Unocc wt Delay	No		No	ZSFUNWT
ZS TLO CONT ENBL	ZS TLO Cont Enable	No		No	ZSTLOEN
TLO SET DURING OC	ZS TLO set during occ	No		No	ZSTLSOC
ZS UI MODE	Zone sensor UI Mode	1=Dual Offsets		1=Dual Offsets	ZSUIM
NETWORK CHKLIST	NETWORK SETUP CHECKLIST	0=Undone, 1=Perform, 2=Done		0=Undone	CHK_NET
DISPLAY SETTINGS	User Display Configurations Menu				
METRIC DISPLAY	Metric Display	Yes/No		No	DISPUNIT
LANGUAGE	Display Language Select	0=English		0=English	LANGUAGE
CONTRAST ADJUST	LCD Contrast Adjustment	1 to 10		5	LCD_CONT
PASSWORD ENABLE?	User Password Protection	Enable/Disable		Enable	PASS_EBL
VIEW USER PASSWORD	View User Password Menu				
CHANGE USER PASSWORD	Change User Password Menu				
QUICK SETUP CONFIG	QUICK SETUP CONFIG MENU				
TIME	Clock Hour and Minute	xx:xx	hh.mm	0	TIME
DATE	Current Date	MM/DD/YYYY		0	DATE
STARTUP DELAY	Unit Startup Delay	10 to 600	sec	30	STARTDLY
UNIT CONTROL TYPE	Unit Control Type	0=TSTAT, 1=SPACE SEN, 2=RAT SEN		0=TSTAT	CTRLTYPE
THERMOSTAT TYPE	Thermostat Hardware Type	0=CONV 2C2H, 1=DIGI 2C2H, 2=CONV 3C2H, 3=DIGI 3C2H, 4=DIGI 2C2H		2=CONV 3C2H	STATTYPE
DIRTY FILTER TIME	Change Filter Timer	0 to 9999	hours	600	FILTIFE
VENT IDF SPEED	Ventilation Only IDF Spd	0 to 100	%	50 (sizes 04-06) 67 (sizes 07-12) 53 (sizes 14 or 20) 56 (size 17) 52 (size 24) 60 (size 26)	FSPDVENT
HEATING STAGE QTY	Number of Heating Stages	0 to 2		2 (all except below): 0 (50 series without FIOF heat), 1 (50 series, sizes 04-06 low or medium heat), 1 (50 series, sizes 07-14 and low heat), 1 (50 series, sizes 07-12 and medium heat)	NUMHSTGS
ECON INSTALLED?	Economizer Installed?	Yes/No		No: no FIOF Yes: FIOF	ECONO
FREE COOL MAX OAT	Free Cooling Max OAT	0 to 90	°F	65	
FIRE SHUTDOWN SW	Fire Shutdown Switch	0=NORM OPEN, 1=NORM CLSD, 2=NO SWITCH		2: no FIOF 0: FIOF	FIRE_CFG
QUICK SET CHKLIST	QUICK SETUP CHECKLIST	0=Undone, 1=Perform, 2=Done		0=Undone	CHK_QUIK

APPENDIX A — SYSTEMVU™ CONTROLLER DISPLAY

Table C — Alerts

DISPLAY TEXT	EXPANDED TEXT	VALUES	WRITE STATUS	POINT
ALERTS/FAULTS	Alerts/Faults Menu			
ACTIVE FAULTS	Active Faults Menu			
ACTIVE ALERTS	Active Alerts Menu			
HISTORY	History Of Faults And Alerts Menu			
RESET FAULT/ALERT	Reset All Current Alarms	Yes/No	Command	ALRESET



APPENDIX A — SYSTEMVU™ CONTROLLER DISPLAY

Table D — Service Main Menu Layout

DISPLAY	EXPANDED TEXT	VALUES	UNITS	WRITE STATUS	POINT
SERVICE	Service Menu				
UNIT TESTS	Unit Tests Menu				
TEST MODE	Service Test Mode Enable	On/Off		Command	
SERVICE TEST	Service Test Menu				
INDEPENDENTS	INDEPENDENT TEST MENU				
ECON POS TEST	Economizer Position Test	0 to 100	%	Command	S_DAMPER
BUMP COMP A1 TEST	Compressor Bump A1 Test	On/Off		Command	S_BMPA1
BUMP COMP A2 TEST	Compressor Bump A2 Test	On/Off		Command	S_BMPA2
LIQ DV VALVE TEST	Liq Diverter Val Rly Tst	On/Off		Command	S_LDVA
RH DIS VALVE TEST	Rht Dischg Valve Rly Tst	On/Off		Command	S_RDVA
RH LIQ VALVE TEST	Reheat Liq Valv Rly Test	On/Off		Command	S_RLVA
CL LIQ VALVE TEST	Cooling Liq Valv Test	On/Off		Command	S_CLVA
CCH RELAY 1 TEST	Crankcase Heater 1 test	On/Off		Command	S_CCHR1
ALARM RELAY TEST	Alarm Output Relay Test	On/Off		Command	S_ALARM
PE1 RELAY TEST	Power Exhaust 1 Test	On/Off		Command	S_PE_1
PE2 RELAY TEST	Power Exhaust 2 Test	On/Off		Command	S_PE_2
FAN TESTS	Indoor and Outdoor Fan Tests Menu				
IDF SPEED TEST	Indoor Fan Speed Test	0 to 100	%	Command	S_IDFSPD
ALL ODF SPD TEST	System ODF speed test	0 to 1200	rpm	Command	S_ODFSPD
ODF 1 SPEED TEST	Outdoor Fan 1 speed test	0 to 1200	rpm	Command	S_ODFSP1
ODF 2 SPEED TEST	Outdoor Fan 2 speed test	0 to 1200	rpm	Command	S_ODFSP2
ODF 3 SPEED TEST	Outdoor Fan 3 speed test	0 to 1200	rpm	Command	S_ODFSP3
IDF MANUAL TRANS	IDF Manual Transition	Yes/No		Command	S_IDFTRN
ODF MANUAL TRANS	ODF Manual Transition	Yes/No		Command	S_ODFTRN
COOL TESTS	Cooling Test Menu				
COOL A1 TEST	Cooling W/Comp. A1 Test	On/Off		Command	S_COOLA1
COOL A2 TEST	Cooling W/Comp. A2 Test	On/Off		Command	S_COOLA2
COOL ALD TEST	Cooling W/Comp.ALD Test	On/Off		Command	S_COLALD
IDF SPEED TEST	Indoor Fan Speed Test	0 to 100	%	Command	S_IDFSPD
ALL ODF SPD TEST	System ODF speed test	0 to 1200	rpm	Command	S_ODFSPD
HUMIDIMIZER TEST	Humidi-MiZer Level Test	0=Off, 1=Subcool, 2=Reheat		Command	S_HMZLEV
HEAT TESTS	Heating Test Menu				
HEAT 1 TEST	Heating Stage 1 Test	On/Off		Command	S_HEAT1
HEAT 2 TEST	Heating Stage 2 Test	On/Off		Command	S_HEAT2
IDF SPEED TEST	Indoor Fan Speed Test	0 to 100	%	Command	S_IDFSPD
AUTOMATIC TEST	Automatic Test Menu				
AUTO INDP TEST	AUTO INDEPENDENT TEST	Yes/No		Command	AUTOINDP
AUTO COOL TEST	RUN AUTO COOLING TEST	Yes/No		Command	AUTOCOOL
AUTO HEAT TEST	RUN AUTO HEATING TEST	Yes/No		Command	AUTOHEAT
AUTO SYSTEM TEST	RUN AUTO SYSTEM TEST	Yes/No		Command	AUTOSYS
UNIT INFORMATION	Unit Information Menu				
MODEL #	Equipment Model number	xxxxxxxxxxxxxxxxxxxx		Command	EQ_MOD
SERIAL #	Equipment Serial number	xxxxxxxxxx		Command	EQ_SER
ENTER MODEL NUMBER	Edit Equipment Model Number				
VERSIONS	Versions Menu				
LC MAIN APP	Application SW Version	CESR131651-xx-xx			FW_CESR
IDF VFD	VFD1 SW Version	text			VFD1_SW
IO BOARD	SIOB1 SW Version	CESR131581-xx-xx			SIOB1_SW
BOOTLOADER	Bootloader SW Version	CESR131659-xx-xx			BL_CESR
USER MEASURED DATA	User Measured Data Menu				
SUPPLY VOLTAGE L1	Supply Voltage Leg 1	0 to 700.0	volt	Command	L1VOLTS
SUPPLY VOLTAGE L2	Supply Voltage Leg 2	0 to 700.0	volt	Command	L2VOLTS
SUPPLY VOLTAGE L3	Supply Voltage Leg 3	0 to 700.0	volt	Command	L3VOLTS
COMP A1 AMPS L1	Comp A1 Amps Leg 1	0 to 100.0	amps	Command	CA1L1_A
COMP A1 AMPS L2	Comp A1 Amps Leg 2	0 to 100.0	amps	Command	CA1L2_A
COMP A1 AMPS L3	Comp A1 Amps Leg 3	0 to 100.0	amps	Command	CA1L3_A
COMP A2 AMPS L1	Comp A2 Amps Leg 1	0 to 100.0	amps	Command	CA2L1_A
COMP A2 AMPS L2	Comp A2 Amps Leg 2	0 to 100.0	amps	Command	CA2L2_A
COMP A2 AMPS L3	Comp A2 Amps Leg 3	0 to 100.0	amps	Command	CA2L3_A

APPENDIX A — SYSTEMVU™ CONTROLLER DISPLAY

Table D — Service Main Menu Layout (cont)

DISPLAY	EXPANDED TEXT	VALUES	UNITS	WRITE STATUS	POINT
<i>USER MEASURED DATA (cont)</i>					
E.HEAT AMPS L1	Elec. Heat Amps Leg 1	0 to 100.0	amps	Command	EHTL1_A
E.HEAT AMPS L2	Elec. Heat Amps Leg 2	0 to 100.0	amps	Command	EHTL2_A
E.HEAT AMPS L3	Elec. Heat Amps Leg 3	0 to 100.0	amps	Command	EHTL3_A
GAS SUPPLY TYPE	Gas Supply Type	0=NATURAL, 1=LP		Command	GASTYPE
GAS INLET PRESS	Gas Inlet Pressure	0 to 20.0	in. wg	Command	GASPRESS
STAGE 1 GAS PRESS	Stage 1 Gas Pressure	0 to 20.0	in. wg	Command	HT1PRESS
STAGE 2 GAS PRESS	Stage 2 Gas Pressure	0 to 20.0	in. wg	Command	HT2PRESS
CONTINUE?	Start Diag Report	Yes/No		Command	GO_DIAG
RUN HOURS & CYCLES					
RUN HOURS DATA MENU					
COMP A1 RUN HOURS	Compressor A1 Run Hours	xxxxxx.x	hours		HR_A1
COMP A2 RUN HOURS	Compressor A2 Run Hours	xxxxxx.x	hours		HR_A2
CMP ALD RUN HOURS	CMP A1 Loader Run Hours	xxxxxx.x	hours		HR_ALDR
ALM RELAY HOURS	Alarm Relay Run Hours	xxxxxx.x	hours		HR_ALM
CCH RELAY HOURS	CCH1 Relay Run Hours	xxxxxx.x	hours		HR_CCHR1
ECON RUN HOURS	Econ Damper Run Hours	xxxxxx.x	hours		HR_DAMP
FULL LOAD HOURS	Unit Full Load Run Hours	xxxxxx.x	hours		HR_FLOAD
FREE COOL HOURS	Free Cooling Run Hours	xxxxxx.x	hours		HR_FREEC
HEAT 1 RUN HOURS	Heat Stage 1 Run Hours	xxxxxx.x	hours		HR_HTR_1
HEAT 2 RUN HOURS	Heat Stage 2 Run Hours	xxxxxx.x	hours		HR_HTR_2
IDF RUN HOURS	Indoor Fan Run Hours	xxxxxx.x	hours		HR_IDF
LDV_A RELAY HOURS	LDV_A Run Hours	xxxxxx.x	hours		HR_LDV_A
MAX IDF RUN HOURS	Max Fan Speed Run Hours	xxxxxx.x	hours		HR_MAXF
ODF1 OUTPUT HOURS	ODF Spd Sig 1 Run Hours	xxxxxx.x	hours		HR_ODF1
ODF2 OUTPUT HOURS	ODF Spd Sig 2 Run Hours	xxxxxx.x	hours		HR_ODF2
ODF3 OUTPUT HOURS	ODF Spd Sig 3 Run Hours	xxxxxx.x	hours		HR_ODF3
PE1 RELAY HOURS	Power Exhaust1 Run Hours	xxxxxx.x	hours		HR_PE_1
PE2 RELAY HOURS	Power Exhaust2 Run Hours	xxxxxx.x	hours		HR_PE_2
RDV_A RELAY HOURS	RDV_A Run Hours	xxxxxx.x	hours		HR_RDV_A
SUBCOOLING HOURS	Reheat level 1 Run Hrs	xxxxxx.x	hours		HR_RQHL1
HOT GAS RH HOURS	Reheat level 2 Run Hrs	xxxxxx.x	hours		HR_RQHL2
TEST MODE HOURS	Service Test Run Hours	xxxxxx.x	hours		HR_STEST
VENT IDF HOURS	Vent IDF Run Hours	xxxxxx.x	hours		HR_VENTF
START COUNT DATA MENU					
COMP A1 STARTS	Compressor A1 Starts	xxxxxx			ST_A1
COMP A2 STARTS	Compressor A2 Starts	xxxxxx			ST_A2
CMP ALD STARTS	CMP A1 Loader Starts	xxxxxx			ST_ALDR
ALM RELAY STARTS	Alarm Relay Starts	xxxxxx			ST_ALM
ALM RESET COUNTS	Alarm Reset Counts	xxxxxx			ST_ALRST
CCH RELAY STARTS	CCH1 Relay Starts	xxxxxx			ST_CCHR1
DAMPER STARTS	Economizer Damper Starts	xxxxxx			ST_DAMP
FULL LOAD STARTS	Unit Full Load Starts	xxxxxx			ST_FLOAD
FREE COOL STARTS	Free Cooling Starts	xxxxxx			ST_FREEC
HEAT 1 STARTS	Heat Stage 1 Starts	xxxxxx			ST_HTR_1
HEAT 2 STARTS	Heat Stage 2 Starts	xxxxxx			ST_HTR_2
IDF STARTS	Indoor Fan Starts	xxxxxx			ST_IDF
LDV A STARTS	LDV_A Starts	xxxxxx			ST_LDV_A
MAX IDF SPD START	Max IDF Speed Starts	xxxxxx			ST_MAXF
ODF OUT 1 STARTS	ODF Spd Signal 1 Starts	xxxxxx			ST_ODF1
ODF OUT 2 STARTS	ODF Spd Signal 2 Starts	xxxxxx			ST_ODF2
ODF OUT 3 STARTS	ODF Spd Signal 3 Starts	xxxxxx			ST_ODF3
RDV A STARTS	RDV_A Starts	xxxxxx			ST_RDV_A
SUBCOOL STARTS	Reheat Level 1 Starts	xxxxxx			ST_RQHL1
HOT GAS RH STARTS	Reheat Level 2 Starts	xxxxxx			ST_RQHL2
PE1 RELAY STARTS	Power Exhaust 1 Starts	xxxxxx			ST_PE_1
PE2 RELAY STARTS	Power Exhaust 2 Starts	xxxxxx			ST_PE_2
POR COUNT	Power Cycle Counts	xxxxxx			ST_POR
TEST MODE STARTS	Service Test Starts	xxxxxx			ST_STEST
VENT FAN STARTS	Ventilation Fan Starts	xxxxxx			ST_VENTF

APPENDIX A — SYSTEMVU™ CONTROLLER DISPLAY

Table D — Service Main Menu Layout (cont)

DISPLAY	EXPANDED TEXT	VALUES	UNITS	WRITE STATUS	POINT
<i>RUN HOURS & CYCLES (cont)</i>					
RESET COUNTS MENU	Reset Counts Menu				
COMP A1 RESET QTY	Comp A1 Resets Count	xxxxxx			RS_A1
COMP A2 RESET QTY	Comp A2 Resets Count	xxxxxx			RS_A2
CMP ALD RESET QTY	A1 Loader Resets Count	xxxxxx			RS_ALDR
ALM RLY RESET QTY	Alarm Relay Resets Count	xxxxxx			RS_ALM
ALM RESET RESETS	Alarm Reset Resets Count	xxxxxx			RS_ALRST
CCH RELAY RESETS	CCH1 Relay Resets Count	xxxxxx			RS_CCHR1
DAMPER RESET QTY	Econ Damper Resets Count	xxxxxx			RS_DAMP
FULL LOAD RESETS	Full Load Resets Count	xxxxxx			RS_FLOAD
FREE COOL RESETS	Free Cooling Reset Count	xxxxxx			RS_FREEC
HEAT 1 RESET QTY	Heat Stage 1 Reset Count	xxxxxx			RS_HTR_1
HEAT 2 RESET QTY	Heat Stage 2 Reset Count	xxxxxx			RS_HTR_2
IDF RESET QTY	Indoor Fan Reset Count	xxxxxx			RS_IDF
LDV A RESET QTY		xxxxxx			RS_LDV_A
MAX IDF RESET QTY	Max IDF Spd Resets Count	xxxxxx			RS_MAXF
ODF1 OUT RESETS	ODF Signal1 Resets Count	xxxxxx			RS_ODF1
ODF2 OUT RESETS	ODF Signal2 Resets Count	xxxxxx			RS_ODF2
ODF3 OUT RESETS	ODF Signal3 Resets Count	xxxxxx			RS_ODF3
PE1 RESET QTY	P.Exhaust 1 Resets Count	xxxxxx			RS_PE_1
PE2 RESET QTY	P.Exhaust 2 Resets Count	xxxxxx			RS_PE_2
POR RESET QTY	Power Cycle Resets Count	xxxxxx			RS_POR
RDV A RESET QTY	rdv_a Resets Count	xxxxxx			RS_RDV_A
SUBCOOL RESET QTY	Reheat Level 1 Reset Count	xxxxxx			RS_RQHL1
HGRH RESET QTY	Reheat Level 2 Reset Count	xxxxxx			RS_RQHL2
TEST MODE RESETS	Service Test Reset Count	xxxxxx			RS_STEST
VENT IDF RESETS	Vent IDF Resets Count	xxxxxx			RS_VENTF
POWER RESET HISTORY	Power On Reset History Menu				
POWRES00	Power Reset Event 00	mm/dd/yy, hh:mm:ss			POWRES00
POWRES01	Power Reset Event 01	mm/dd/yy, hh:mm:ss			POWRES01
POWRES02	Power Reset Event 02	mm/dd/yy, hh:mm:ss			POWRES02
POWRES03	Power Reset Event 03	mm/dd/yy, hh:mm:ss			POWRES03
POWRES04	Power Reset Event 04	mm/dd/yy, hh:mm:ss			POWRES04
POWRES05	Power Reset Event 05	mm/dd/yy, hh:mm:ss			POWRES05
POWRES06	Power Reset Event 06	mm/dd/yy, hh:mm:ss			POWRES06
POWRES07	Power Reset Event 07	mm/dd/yy, hh:mm:ss			POWRES07
POWRES08	Power Reset Event 08	mm/dd/yy, hh:mm:ss			POWRES08
POWRES09	Power Reset Event 09	mm/dd/yy, hh:mm:ss			POWRES09
ALARM RESET HISTORY	Alarm Reset History Menu				
ALMRES00	Alarm Reset Event 00	mm/dd/yy, hh:mm:ss			ALMRES00
ALMRES01	Alarm Reset Event 01	mm/dd/yy, hh:mm:ss			ALMRES01
ALMRES02	Alarm Reset Event 02	mm/dd/yy, hh:mm:ss			ALMRES02
ALMRES03	Alarm Reset Event 03	mm/dd/yy, hh:mm:ss			ALMRES03
ALMRES04	Alarm Reset Event 04	mm/dd/yy, hh:mm:ss			ALMRES04
ALMRES05	Alarm Reset Event 05	mm/dd/yy, hh:mm:ss			ALMRES05
ALMRES06	Alarm Reset Event 06	mm/dd/yy, hh:mm:ss			ALMRES06
ALMRES07	Alarm Reset Event 07	mm/dd/yy, hh:mm:ss			ALMRES07
ALMRES08	Alarm Reset Event 08	mm/dd/yy, hh:mm:ss			ALMRES08
ALMRES09	Alarm Reset Event 09	mm/dd/yy, hh:mm:ss			ALMRES09
ALMRES10	Alarm Reset Event 10	mm/dd/yy, hh:mm:ss			ALMRES10
ALMRES11	Alarm Reset Event 11	mm/dd/yy, hh:mm:ss			ALMRES11
ALMRES12	Alarm Reset Event 12	mm/dd/yy, hh:mm:ss			ALMRES12
ALMRES13	Alarm Reset Event 13	mm/dd/yy, hh:mm:ss			ALMRES13
ALMRES14	Alarm Reset Event 14	mm/dd/yy, hh:mm:ss			ALMRES14
ALMRES15	Alarm Reset Event 15	mm/dd/yy, hh:mm:ss			ALMRES15
ALMRES16	Alarm Reset Event 16	mm/dd/yy, hh:mm:ss			ALMRES16
ALMRES17	Alarm Reset Event 17	mm/dd/yy, hh:mm:ss			ALMRES17
ALMRES18	Alarm Reset Event 18	mm/dd/yy, hh:mm:ss			ALMRES18
ALMRES19	Alarm Reset Event 19	mm/dd/yy, hh:mm:ss			ALMRES19

APPENDIX A — SYSTEMVU™ CONTROLLER DISPLAY

Table D — Service Main Menu Layout (cont)

DISPLAY	EXPANDED TEXT	VALUES	UNITS	WRITE STATUS	POINT
HARDWARE	Hardware Information Menu				
HARDWARE INPUTS	Hardware Inputs Menu				
OAT SENSOR VALUE	Outdoor Air Temp Sensor	xxx.x	°F		OAT_LOC
RAT SENSOR VALUE	Return Air Temp Sensor	xxx.x	°F		RAT_LOC
SPT SENSOR VALUE	Space Temperature Sensor	xxx.x	°F		SPT_LOC
SPTO SENSOR VALUE	Local Space Temp Offset	xxx.x	°F delta		SPTO_LOC
SPRH SENSOR VALUE	SPRH Sensor Value	0 to 100	°F		SPRH_LOC
OARH SENSOR VALUE	OARH Sensor Value	0 to 100	%		OARH_LOC
RARH SENSOR VALUE	RARH Sensor Value	0 to 100	%		RARH_LOC
IAQ SENSOR VALUE	IAQ Sensor Value	xxxx	ppm		IAQ_LOC
OAQ SENSOR VALUE	OAQ Sensor Value	xxxx	ppm	ppm	OAQ_LOC
OACFM SENSOR VAL	OACFM Sensor Value	xxx.x	CFM		OACFM_LOC
ASSIGNED INPUTS/OUTPUTS	Assigned Input/Output Channels				
AI06 FUNCTION	Assigned AI06 Function	0=None, 1=IAQ, 2=OARH, 3=RARH, 4=OAQ, 5=SPRH, 6=OACFM			MBBAI06F
AI07 FUNCTION	Assigned AI07 Function	0=None, 1=IAQ, 2=OARH, 3=RARH, 4=OAQ, 5=SPRH, 6=OACFM			MBBAI07F
AI08 FUNCTION	Assigned AI08 Function	0=None, 1=IAQ, 2=OARH, 3=RARH, 4=OAQ, 5=SPRH, 6=OACFM			MBBAI08F
IO AI10 FUNCTION	Assigned S-AI01 Function	0=None, 1=IAQ, 2=OARH, 3=RARH, 4=OAQ, 5=SPRH, 6=OACFM			SIOAI01F
DI02 FUNCTION	Assigned DI02 Function	0=None, 1=COFS, 2=REMOCC, 3=REMOFF, 4=FILTER, 5=ENTHALPY, 6=GEN STAT			MBBDI02F
DI04 FUNCTION	Assigned DI04 Function	0=None, 1=COFS, 2=REMOCC, 3=REMOFF, 4=FILTER, 5=ENTHALPY, 6=GEN STAT			MBBDI04F
DI12 FUNCTION	Assigned DI12 Function	0=None, 1=COFS, 2=REMOCC, 3=REMOFF, 4=FILTER, 5=ENTHALPY, 6=GEN STAT			MBBDI12F
DI13 FUNCTION	Assigned DI13 Function	0=None, 1=COFS, 2=REMOCC, 3=REMOFF, 4=FILTER, 5=ENTHALPY, 6=GEN STAT			MBBDI13F
DI14 FUNCTION	Assigned DI14 Function	0=None, 1=COFS, 2=REMOCC, 3=REMOFF, 4=FILTER, 5=ENTHALPY, 6=GEN STAT			MBBDI14F

APPENDIX A — SYSTEMVU™ CONTROLLER DISPLAY

Table D — Service Main Menu Layout (cont)

DISPLAY	EXPANDED TEXT	VALUES	UNITS	WRITE STATUS	POINT
<i>HARDWARE (cont)</i>					
IO DI01 FUNCTION	Assigned S-DI01 Function	0=None, 1=COFS, 2=REMOCC, 3=REMOFF, 4=FILTER, 5=ENTHALPY, 6=GEN STAT			SIODI01F
RELAY 06 FUNCTION	Assigned Rly 06 Function	0=None, 1=ALM Relay, 2=PE1, 3=PE2			MBBRY06F
RELAY 11 FUNCTION	Assigned Rly 11 Function	0=None, 1=ALM Relay, 2=PE1, 3=PE2			MBBRY11F
MBB PART #	MBB Part Number	CEPL131117-xx-R			BD_CEPL
MBB PP	MBB Program Part Number	CEPP130644-xx-xx-xx-R			BD_CEPP
MBB SERIAL #	Base Board Serial Number	xxxxNxxxxxx			BD_SER
CALIBRATION					
Calibration Menu					
OAT TRIMOFFSET	OAT Sensor Trim Offset	-10.0 to 10.0	°F	Configurable	OAT_TRIM
RAT TRIM OFFSET	RAT Sensor Trim Offset	-30.0 to 30.0	°F	Configurable	RAT_TRIM
FST TRIM OFFSET	FST Sensor Trim Offset	-10.0 to 10.0	°F	Configurable	FST_TRIM
SPT TRIMOFFSET	SPT Sensor Trim Offset	-30.0 to 30.0	°F	Configurable	SPT_TRIM
SLIDER SEN. TRIM	SPTO Sensor Offset Trim	-1.0 to 1.0	°F	Configurable	SPTOTRIM
SPRH TRIM OFFSET	SPRH Sensor Offset Trim	-15 to 15	%	Configurable	SPRHTRIM
IAQ TRIM OFFSET	IAQ Sensor Trim Offset	-200 to 200	ppm	Configurable	IAQ_TRIM
OAQ TRIM OFFSET	OAQ Sensor Trim Offset	-200 to 200	ppm	Configurable	OAQ_TRIM
OARH TRIM OFFSET	OARH Sensor Trim Offset	-15 to 15	%	Configurable	OARHTRIM
RARH TRIM OFFSET	RARH Sensor Trim Offset	-15 to 15	%	Configurable	RARHTRIM
CIR.A SSP TRIM	Cir.A SSP Sensor Trim	-50 to 50	psig	Configurable	SSPATRIM
CIR.A SDP TRIM	Cir.A SDP Sensor Trim	-50 to 50	psig	Configurable	SDPATRIM
ECO FEEDBACK TRIM	Econ Fdback Trim Offset	-15 to 15	%	Configurable	EC1DTRIM
OACFM TRIMOFFSET	OACFM Sensor Trim Offset	-10 to 10	CFM	Configurable	OCFMTRIM
COMMISSION REPORTS					
Commission Report Menu					
SYSTEM STARTUP CHECKLIST MENU					
SYSTEM STARTUP CHECKLIST	QUICK SETUP CHECKLIST	0=Undone, 1=Perfom, 2=Done		Configurable	CHK_QUIK
QUICK SET CHKLIST	NETWORK SETUP CHECKLIST	0=Undone, 1=Perfom, 2=Done		Configurable	CHK_NET
NETWORK CHKLIST	CheckList Auto Test	0=Undone, 1=Perfom, 2=Done		Configurable	CHK_ATST
SYSTEM AUTOTEST					
ADVANCED SERVICE					
Advanced Service Restricted Access Menu					
RESTORE DEFAULTS?	Restore Factory Defaults	Yes/No		Command	RESFDFLT
EDIT MODEL NUMBER	Edit Equip Mod Num Menu				
EDIT SER NUMBER	Edit Equip Ser Num Menu				
RESET COMPONENT DATA MENU					
CLEAR COMPONENT DATA	Reset Compressor A1 Data	Yes/No		Command	CR_A1
COMP A1 DATA	Reset Compressor A2 Data	Yes/No		Command	CR_A2
COMP A2 DATA	Reset CompressorALD Data	Yes/No		Command	CR_ALD
LOADER DATA	Reset Alarm Relay Data	Yes/No		Command	CR_ALM
ALARM RELAY DATA	Reset Alarm Resets Data	Yes/No		Command	CR_ALRST
ALARM RESET DATA	Reset CCH1 Relay Data	Yes/No		Command	CR_CCHR1
CCH RELAY DATA	Reset Econ Damper Data	Yes/No		Command	CR_DAMP
ECON DAMPER DATA	Reset Full Load Data	Yes/No		Command	CR_FLOAD
FULL LOAD DATA	Reset Free Cooling Data	Yes/No		Command	CR_FREEC
FREE COOL DATA	Reset Heat Stage 1 Data	Yes/No		Command	CR_HTR_1
HEAT 1 DATA	Reset Heat Stage 2 Data	Yes/No		Command	CR_HTR_2
HEAT 2 DATA	Reset Indoor Fan Data	Yes/No		Command	CR_IDF
IDF RUN DATA	Reset Max Fan Speed Data	Yes/No		Command	CR_MAXF
IDF MAX SPD DATA	Reset ODF Spd Sig 1 Data	Yes/No		Command	CR_ODF1
ODF1 OUTPUT DATA					

APPENDIX A — SYSTEMVU™ CONTROLLER DISPLAY

Table D — Service Main Menu Layout (cont)

DISPLAY	EXPANDED TEXT	VALUES	UNITS	WRITE STATUS	POINT
<i>ADVANCED SERVICE (cont)</i>					
ODF2 OUTPUT DATA	Reset ODF Spd Sig 2 Data	Yes/No		Command	CR_ODF2
ODF3 OUTPUT DATA	Reset ODF Spd Sig 3 Data	Yes/No		Command	CR_ODF3
PE1 RELAY DATA	Reset Pwr Exhaust 1 Data	Yes/No		Command	CR_PE_1
PE2 RELAY DATA	Reset Pwr Exhaust 2 Data	Yes/No		Command	CR_PE_2
POWER RESET DATA	Reset Power Resets Data	Yes/No		Command	CR_POR
TEST MODE DATA	Reset Service Test Data	Yes/No		Command	CR_STEST
VENT IDF DATA	Reset Vent IDF Data	Yes/No		Command	CR_VENTF



APPENDIX A — SYSTEMVU™ CONTROLLER DISPLAY

Table E — Inputs Main Menu Layout

DISPLAY	EXPANDED TEXT	VALUES	UNITS	WRITE STATUS	POINT
INPUTS	Inputs Menu				
TEMPERATURES	Temperatures Menu				
SUPPLY AIR TEMP	Supply Air Temperature	xxx.x	°F		SAT
OUTDOOR AIR TEMP	Outdoor Air Temperature	xxx.x	°F	Forcible	OAT
RETURN AIR TEMP	Return Air Temperature	xxx.x	°F	Forcible	RAT
SPACE TEMPERATURE	Space Temperature	xxx.x	°F	Forcible	SPACE_T
SLIDER OFFSET VAL	Space Temperature Offset	xx.x	°F	Forcible	SPTO
CIR.A SUC TEMP	Cir.A Sat.Suction Temp	xxx.x	°F		SST_A
CIR.A DIS. TEMP	Cir.A Sat.Discharge Temp	xxx.x	°F		SDT_A
FAN SUPPLY TEMP	Fan Supply Air Temp	xxx.x	°F		FST
PRESSURES	Pressures Menu				
CIR.A SUC. PRESS	Cir.A Suction Pressure	xxx.x	psig		SSP_A
CIR.A DIS. PRESS	Cir.A Discharge Pressure	xxx.x	psig		SDP_A
CIR.A PRESS RATIO	Circuit A Pressure Ratio	xxx.x			CIRA_PR
BAROMETRIC PRESS	Barometric Pressure	xxx.x	in. Hg	Forcible	BARP
THERMOSTAT	Thermostat Inputs Menu				
TSTAT G INPUT	Thermostat G Input	On/Off		Forcible	G
TSTAT Y1 INPUT	Thermostat Y1 Input	On/Off		Forcible	Y1
TSTAT Y2 INPUT	Thermostat Y2 Input	On/Off		Forcible	Y2
TSTAT Y3 INPUT	Thermostat Y3 Input	On/Off		Forcible	Y3
TSTAT W1 INPUT	Thermostat W1 Input	On/Off		Forcible	W1
TSTAT W2 INPUT	Thermostat W2 Input	On/Off		Forcible	W2
SWITCH INPUTS	Switch Inputs Menu				
IGC FAN REQUEST	IGC Fan On Request (IFO)	On/Off		Forcible	IGC_IFO
CIR.A HPS	Cir.A High Pressure Sw	Open/Close		Forcible	CIRA_HPS
HUMIDISTAT	Humidistat I/P	On/Off		Forcible	HUMDSTAT
FIRE SHUTDOWN	Fire Shutdown Switch	Alarm/Normal		Forcible	FIREDOWN
COFS	COFS Switch State	High/Low		Forcible	COFS
FILTER STATUS SW	Filter Status Switch	Dirty/Clean		Forcible	FILTSTAT
REMOTE OCC SWITCH	Remote Occupancy Switch	On/Off		Forcible	REMOCC
REMOTE SHUTDOWN	Remote Shutdown Switch	On/Off		Forcible	REMSHUT
GENERAL STATUS SW	General Status Switch	Alarm/Normal		Forcible	GENSTAT
ENTHALPY SWITCH	Enthalpy Switch	High/Low		Forcible	ENTH_SW
ANALOG INPUTS	Analog Inputs Menu				
ECON ACT POSITION	Econo Actual Position	0 to 100	%		DAMPPOS
SPRH LEVEL	Space RH	0 to 100	%	Forcible	SPRH
OARH LEVEL	OA Relative Humidity	0 to 100	%	Forcible	OARH
RARH LEVEL	RA Relative Humidity	0 to 100	%	Forcible	RARH
IAQ LEVEL	Indoor Air Quality Level	xxxx	ppm	Forcible	IAQ
OAQ LEVEL	OA Quality Level	xxxx	ppm	Forcible	OAQ
OUTDOOR AIR CFM	Outdoor Air in CFM	xxx.x	CFM	Forcible	OACFM
GENERAL INPUTS	General Inputs Menu				
FILTER TIME LEFT	Filter Hour Remaining	xxxx	hours		FILTLEFT
RESET FILTER TIME	Reset Filter Timer	Yes/No		Command	RESETFLT
OUTDOOR ENTHALPY	Outdoor Air Enthalpy	xxx.x	Btu/lb	Forcible	OA_ENTH
RETURN ENTHALPY	Return Air Enthalpy	xxx.x	Btu/lb	Forcible	RA_ENTH
DIFF AIR QUALITY	Differential Air Quality	xxxx	ppm		AQ_DIFF
INDOOR FAN VFD DATA	Indoor Fan VFD Data				
IDF VFD RUN HOURS	IDF VFD Motor Run Hours	xxxxxxxx	hours		VFDMHOUR
IDF VFD KW HOURS	IDF VFD Cumulative kWh	xxxxx	kWh		KWHCNTR
VFD REF SPEED	IDF VFD Reference Speed	0 to 1000	%		REFSPEED
VFD STATUS WORD	IDF VFD Status Word	xxxxxxxx			VFD1STSW
IDF VFD FEEDBACK	IDF VFD Actual Speed %	xxxxx	%		MAV
VFD OUTPUT KW	IDF VFD Output Power kW	0 to 1000	kWh		OUTPWRKW
VFD OUTPUT HP	IDF VFD Output Power HP	0 to 1000	HP		OUTPWRHP
VFD OUTPUT VOLTS	IDF VFD Output Voltage	xxxxx	volts		OUTMVOLT
VFD OUTPUT FREQ	IDF VFD Output Freq.	xxxxx.x	Hz		OUTMFREQ
VFD OUTPUT AMPS	IDF VFD Output Amps	xxx.xx	amps		OUTMCUR
IDF VFD DC VOLTS	IDF VFD DC Bus Voltage	xxx	volts		DCLNVOLT
IDF VFD HSNK TEMP	IDF VFD Heatsink Temp	xxx.x	°F		HTSINKT
IDF VFD ALM WORD	IDF VFD Alarm Word	xxxxxxxx			ALMERRC

APPENDIX A — SYSTEMVU™ CONTROLLER DISPLAY

Table E — Inputs Main Menu Layout (cont)

DISPLAY	EXPANDED TEXT	VALUES	UNITS	WRITE STATUS	POINT
<i>GENERAL INPUTS (cont)</i>					
VFD FAULT DETAIL	IDF VFD Fault Detail	0=NONE, 1=PWR CARD, 2=EARTH FLT, 3=CTRL WORD, 4=OVER CURR, 5=OVER TEMP, 6=OVERLOAD, 7=UNDERVOLT, 8=OVER VOLT, 9=SHORT CIR, 10=PHASELOSS, 11=U LOSS, 12=V LOSS, 13=W LOSS, 14=CTRL VOLT, 15=VDD LOW, 16=MULTIPLE, 17=UNEXPECT			SVFDFLT
VFD WARN DETAIL	IDF VFD Warning Detail	0=NONE, 1=VOLTAGE, 2=CURRENT, 3=THERMAL, 4=MULTIPLE, 5=UNEXPECT			SVFDWAR
NETWORK					
BMS OCC REQUEST	BMS Occupancy Request	0=UNOCC, 1=OCCUPIED, 2=DISABLED		Forcible	BMS_OCC
LINKAGE OCC REQ	Linkage Occupied Request	0=Unocc, 1=Occupied, 2=Disabled			LNK_OCC
OAT NETWORK VALUE	Network OAT Value	xxx.x	°F		OAT_NET
RAT NETWORK VALUE	Network Return Air Temp	xxx.x	°F		RAT_NET
SPT NETWORK VAL.	Network Space Temp Value	xxx.x	°F		SPT_NET
OARH NETWORK VAL.	Network OARH Value	0 to 100	%		OARH_NET
RARH NETWORK VAL.	Network RARH Value	0 to 100	%		RARH_NET
IAQ NETWORK VALUE	Network IAQ Value	xxxx	ppm		IAQ_NET
OAQ NETWORK VALUE	Network OAQ Value	xxxx	ppm		OAQ_NET
OACFM NETWORK VAL	Network OACFM Value	xxxx	CFM		OACFM_NET
ZS SENSOR INFO					
ZS SPACE TEMP	Zone Sensor Temp Out	-40 to 245	°F		ZSZT
ZS SPACE RH	Zone Sensor Humidity Out	0 to 100	%		ZSSPRH
ZS SPOFFSET	ZS Setpoint Offset Output	-10 to 10	°F delta		ZSSPTO
ZS OVER TIME LEFT	ZS Override Time Remaining	0 to 600	min		ZSOTR
ZS TEMPERATURE	ZS Space Temperature				
ZS1 TEMPERATURE	Zone Sensor 1 Temp	-40 to 245	°F		ZS1ZT
ZS2 TEMPERATURE	ZS2 Temperature	-40 to 245	°F		ZS2ZT
ZS3 TEMPERATURE	ZS3 Temperature	-40 to 245	°F		ZS3ZT
ZS4 TEMPERATURE	ZS4 Temperature	-40 to 245	°F		ZS4ZT
ZS5 TEMPERATURE	ZS5 Temperature	-40 to 245	°F		ZS5ZT
ZS HUMIDITY	ZS Space Humidity				
ZS1 HUMIDITY	ZS1 Humidity	0 to 100	%		ZS1ZHUM
ZS2 HUMIDITY	ZS2 Humidity	0 to 100	%		ZS2ZHUM
ZS3 HUMIDITY	ZS3 Humidity	0 to 100	%		ZS3ZHUM
ZS4 HUMIDITY	ZS4 Humidity	0 to 100	%		ZS4ZHUM
ZS5 HUMIDITY	ZS5 Humidity	0 to 100	%		ZS5ZHUM
ZS CSP OFFSET	ZS Cool Setpoint Offset				
ZS1 CSP OFFSET	ZS1 Cool Setpoint Offset	-10 to 10	°F delta		ZS1CSOFF
ZS2 CSP OFFSET	ZS2 Cool Setpoint Offset	-10 to 10	°F delta		ZS2CSOFF
ZS3 CSP OFFSET	ZS3 Cool Setpoint Offset	-10 to 10	°F delta		ZS3CSOFF
ZS4 CSP OFFSET	ZS4 Cool Setpoint Offset	-10 to 10	°F delta		ZS4CSOFF
ZS5 CSP OFFSET	ZS5 Cool Setpoint Offset	-10 to 10	°F delta		ZS5CSOFF
ZS HSP OFFSET	ZS Heat Setpoint Offset				
ZS1 HSP OFFSET	ZS1 Heat Setpoint Offset	-10 to 10	°F delta		ZS1HSOFF
ZS2 HSP OFFSET	ZS2 Heat Setpoint Offset	-10 to 10	°F delta		ZS2HSOFF
ZS3 HSP OFFSET	ZS3 Heat Setpoint Offset	-10 to 10	°F delta		ZS3HSOFF
ZS4 HSP OFFSET	ZS4 Heat Setpoint Offset	-10 to 10	°F delta		ZS4HSOFF
ZS5 HSP OFFSET	ZS5 Heat Setpoint Offset	-10 to 10	°F delta		ZS5HSOFF

APPENDIX A — SYSTEMVU™ CONTROLLER DISPLAY

Table E — Inputs Main Menu Layout (cont)

DISPLAY	EXPANDED TEXT	VALUES	UNITS	WRITE STATUS	POINT
ZS SENSOR INFO (cont)					
ZS OCC TIME OVER	ZS Occ Timed Override				
ZS1 OCC TIME OVER	ZS1 Override Time Remaining	0 to 600	min		ZS1OTR
ZS2 OCC TIME OVER	ZS2 Override Time Remaining	0 to 600	min		ZS2OTR
ZS3 OCC TIME OVER	ZS3 Override Time Remaining	0 to 600	min		ZS3OTR
ZS4 OCC TIME OVER	ZS4 Override Time Remaining	0 to 600	min		ZS4OTR
ZS5 OCC TIME OVER	ZS5 Override Time Remaining	0 to 600	min		ZS5OTR



APPENDIX A — SYSTEMVU™ CONTROLLER DISPLAY

Table F — Outputs Main Menu Layout

DISPLAY	EXPANDED TEXT	VALUES	UNITS	WRITE STATUS	POINT
OUTPUTS	Outputs Menu				
GENERAL OUTPUTS	General Outputs Menu				
IDF SPEED OUTPUT	Commanded IDF Speed	xxx	%		FANSPEED
ECON CMD POSITION	Econo Commanded Position	xxx	%	Forcible	DAMPCMD
CCH RELAY	CCH Relay 1 State	On/Off			CCHR1
PE1 RELAY	Power Exhaust 1 Relay	On/Off		Forcible	PE1
PE2 RELAY	Power Exhaust 2 Relay	On/Off		Forcible	PE2
ALARM RELAY	Alarm Output Relay State	On/Off		Forcible	ALMOUT
DD IDF HI SPD RLY	DD IDF high speed relay	On/Off			FSPDHRLY
DD IDF MD SPD RLY	DD IDF med. Speed relay	On/Off			FSPDMRLY
DD IDF LO SPD RLY	DD IDF low speed relay	On/Off			FSPDLRLY
COOLING OUTPUTS	Cooling Outputs Menu				
COMPRESSOR A1	Circuit A Compressor 1	On/Off			COMP_A1
COMPRESSOR A2	Circuit A Compressor 2	On/Off			COMP_A2
COMPRESSOR ALD	Circuit A CMP A1 Loader	On/Off			COMP_ALD
LIQ DIV VALVE A	Liquid Diverter Val CirA	Enable/Disable			LDV_A
RHT DISCH VALVE A	Reheat Dischg Valve CirA	Enable/Disable			RDV_A
RHT LIQ VALVE A	Reheat Liquid Valve CirA	Enable/Disable			RLV_A
COOL LIQ VALVE A	Cooling Liq Valve CirA	Enable/Disable			CLV_A
COMMANDED ODF SPD	Commanded ODF Speed	xxxx	rpm		ODFSPD
ODF SPEED OUT 1	ODF Speed Signal Output1	xxxx	rpm		ODF1SPD
ODF SPEED OUT 2	ODF Speed Signal Output2	xxxx	rpm		ODF2SPD
ODF SPEED OUT 3	ODF Speed Signal Output3	xxxx	rpm		ODF3SPD
HEATING OUTPUTS	Heating Outputs Menu				
HEAT 1 RELAY	Heat Stage 1 Relay	On/Off			HEAT_1
HEAT 2 RELAY	Heat Stage 2 Relay	On/Off			HEAT_2



APPENDIX A — SYSTEMVU™ CONTROLLER DISPLAY

Table G — USB Main Menu Layout

DISPLAY TEXT	EXPANDED TEXT	VALUES	UNITS	WRITE STATUS	POINT
USB	USB Menu				
DATA ACQUISITION	Data Acquisition Menu				
TREND STATUS	USB TREND STATUS	0=IDLE, 1=TRENDING, 2=NO POINTS, 3=USB FULL			TRNDSTAT
TREND DURATION	USB TREND DURATION	0=1 MINUTE, 1=5 MINUTES, 2=15 MINUTES, 3=30 MINUTES, 4=1 HOUR, 5=3 HOURS, 6=8 HOURS, 7=12 HOURS, 8=1 DAYS, 9=1.5 DAYS, 10=2 DAYS, 11=3 DAYS, 12=5 DAYS, 13=1 WEEK, 14=2 WEEK, 15=4 WEEK, 16=USB FULL		Command	TRND DUR
TREND RATE	USB TREND RATE	1 to 300		Command	TRND RATE
TREND POINTS FROM	USB TREND POINTS FROM	0=FILE, 1=LIST		Command	TRND PNTS
TREND FROM USB FILE?	TREND FROM USB FILE MENU				
TREND FROM PRELIST?	TREND FROM PRELIST MENU				
EQUIP PERFORMANCE	TREND EQUIP PERFORMANCE	On/Off		Command	TRND EQPR
GEN. INPUT/OUTPUT	TREND GEN INPUTS/OUTPUTS	On/Off		Command	TRND IO
COOL PERFORMANCE	TREND COOL PERFORMANCE	On/Off		Command	TRND CLPR
HEAT PERFORMANCE	TREND HEAT PERFORMANCE	On/Off		Command	TRND HTPR
COOL DIAGNOSTIC	TREND COOLING DIAGNOSTIC	On/Off		Command	TRND CLDG
IDF DIAGNOSTIC	TREND IDF DIAGNOSTIC	On/Off		Command	TRND IDF
VENT DIAGNOSTIC	TREND VENTILATION	On/Off		Command	TRND VENT
TREND GO?	Start USB Trending	Yes/No		Command	TREND_EN
SAVE CONFIGS TO FILE	Save Configuration to file				
SAVE CONFIGS	Make Config Backup File	Start/Stop		Command	DDBCKUP
SAVE CONFIG STATUS	Backup File is ready	0=IDLE, 1=SUCCESS, 2=FAILURE			BACKUP_R
SAVE CONFIGS FROM FILE	Save Configuration from file				
FIND CONFIG FILE	USB Find Restore File	Yes/No		Command	BACKFILE
FILE TRANSFER	File Transfer Menu				
BACKUP SERVICE FILES	BACKUP SERVICE FILES				
UPGRADE SOFTWARE	Upgrade Software Menu				
FIND APPLICATION FILE	USB Search For App File	Yes/No		Command	APPFILE

APPENDIX B — SYSTEMVU™ CONTROLLER TEXT POINT REFERENCE

SystemVu Display Name = MODE
 SystemVu Text point = MODETEXT
 SystemVu Numeric point = SYS_MODE

MODETEXT	SYS_MODE
OFF	1
COOL	2
HEAT	3
VENT	4
TEST	5

SystemVu Display Name = SUB-MODE
 SystemVu Text point = SUBMTEXT
 SystemVu Numeric point = SUB_MODE

SUBMTEXT	SUB_MODE
ECON FREE COOLING	3
UNOCC. FREE COOL	4
MECH. COOLING	5
ECON/MECH COOLING	6
DEHUM/MECH COOLING	7
DEHUMIDIFYING	8
DEHUM PREVENTED	9
COOLING PREVENTED	10
SHUTTING COOL OFF	11
HEATING	13
HEATING PREVENTED	14
SHUTTING HEAT OFF	15
OA TEMPERING	16
MODE TIMEGUARD	19, 26
SUPPLY FAN ON	20
MANUAL TEST	23
AUTO TEST	24
SHUTTING TEST OFF	25
IDLE - NO DEMAND	27
UNIT DISABLED	28
URGENT SHUTDOWN	29
SAFETY CONTROL	30
STARTING UP	31

SystemVu Display Name = VENT MODE
 SystemVu Text point = VENTTEXT
 SystemVu Numeric point = VENTSTAT

VENTTEXT	VENTSTAT
SUPPLY FAN OFF	0
CIRCULATION	1
PRE-OCC PURGE	2
IAQ OVERRIDE	3
MINIMUM POSITION	4
UNDER VENTILATION	5
OVER VENTILATION	6
DCV POSITION	7
FREECOOL POSITION	8
TESTING	9

SystemVu Display Name = DEMAND
 SystemVu Text point = SYSDMDT
 SystemVu Numeric point = SYS_DMD

SYSDMDT	SYS_DMD
NO DEMAND	0
DEHUM	4, 12
FAN ONLY	8
LOW COOL	17, 25
MED COOL	18, 26
HIGH COOL	19, 27
LOW COOL DEHUM	21, 29
MED COOL DEHUM	22, 30
HIGH COOL DEHUM	23, 31
LOW HEAT	33, 37, 41, 45
HIGH HEAT	35, 39, 43, 47
SERVICE TEST	49
SHUTDOWN	65
SAFETY FAULT	66
EMERGENCY	67
UFC LOW COOL	81
UFC MED COOL	82
LOW UFC DEHUM	85
MED UFC DEHUM	86
HIGH UFC DEHUM	87
UFC HIGH COOL	83
SUP.AIRTEMPERING	129, 137

APPENDIX C — NAVIGATOR™ DISPLAY

Table H — MODE — RUN STATUS

ITEM	EXPANSION	RANGE	UNIT	WRITE STATUS	POINT
RUN STATUS					
VIEW	Auto View of Run Status				
MODE	Operating Mode	see Appendix B			MODETEXT
SUBM	Operating Sub-Mode	see Appendix B			SUBMTEXT
S.DMD	System Demand	see Appendix B			SYS_DMDT
LINK	Linkage Active	Yes/No		YES	LNK_ACT
OCC	Currently Occupied	Yes/No		YES	OCCUPIED
SAT	Supply Air Temperature	xxx.x	°F		SAT
COOL	Cooling Status Menu				
LA.ST	Low Ambient Ctrl Status	0=Normal, 1=Entering, 2=Low Ambient, 3=Exiting			LACTRLST
RDHL	Requested Dehum Level	0 to 2			REQDHLEV
MC.ON	Mechanical Cool active?	Yes/No		YES	MECHCOOL
MAX.C	Max Allowed Cool Stages	0 to 3			MAXCSTGS
REQ.C	Requested Cooling Stages	0 to 3			REQCSTGS
ACT.C	Actual Cool Stage Active	x			ACTCSTGS
TG.A1	Compressor A1 Timeguard	xxx	sec		TIMGD_A1
TG.A2	Compressor A2 Timeguard	xxx	sec		TIMGD_A2
TG.AL	Cmp Loader Timeguard	xxx	sec		TIMG_ALD
FC.ON	Free Cooling Active	Yes/No			FREECOOL
RDHS	Req Compr Dehum Stgs	0 to 3			REQDSTGS
HEAT	Heating Status Menu				
REQ.H	Requested Heating Stages	0 to 2			REQHSTGS
ACT.H	Actual Heat Stage Active	x		YES	ACTHSTGS
MAX.H	Max Allowed Heat Stages	0 to 2			MAXHSTGS
TG.H1	Heat Stage 1 Timeguard	xxx	sec		TIMGD_H1
TG.H2	Heat Stage 2 Timeguard	xxx	sec		TIMGD_H2
VENT	Ventilation Status Menu				
VENT	Ventilation Status	see Appendix B			VENTTEXT
EC.MP	Min Position in Effect	xxx	%	YES	MIN_POS
OCC	Currently Occupied	Yes/No		YES	OCCUPIED
I.FAN	Indoor Fan Status Menu				
M.CUR	IDF VFD Output Amps	0 to 655.35			OUTMCUR
M.HP	IDF VFD Output Power hp	0 to 1000			OUTPWRHP
VFD.F	IDF VFD Fault Detail	0=NONE, 1=PWR CARD, 2=EARTH FLT, 3=CTRL WORD, 4=OVER CURR, 5=OVER TEMP, 6=OVERLOAD, 7=UNDERVOLT, 8=OVER VOLT, 9=SHORT CIR, 10=PHASELOSS, 11=U LOSS, 12=V LOSS, 13=W LOSS, 14=CTRL VOLT, 15=VDD LOW, 16=MULTIPLE, 17=UNEXPECT			SVFDFLT
VFD.W	IDF VFD Warning Detail	0=NONE, 1=VOLTAGE, 2=CURRENT, 3=THERMAL, 4=MULTIPLE, 5=UNEXPECT			SVFDWAR
A.IO	Assigned I/O Channels				
AI06	Assigned AI06 Function	0=None, 1=IAQ, 2=OARH, 3=RARH, 4=OAQ, 5=SPRH, 6=OACFM			MBBAI06F

APPENDIX C — NAVIGATOR™ DISPLAY

Table H — MODE — RUN STATUS (cont)

ITEM	EXPANSION	RANGE	UNIT	WRITE STATUS	POINT
<i>A.IO (cont)</i>					
AI07	Assigned AI07 Function	0=None, 1=IAQ, 2=OARH, 3=RARH, 4=OAQ, 5=SPRH, 6=OACFM			MBBAI07F
AI08	Assigned AI08 Function	0=None, 1=IAQ, 2=OARH, 3=RARH, 4=OAQ, 5=SPRH, 6=OACFM			MBBAI08F
SA10	Assigned S-AI01 Function	0=None, 1=IAQ, 2=OARH, 3=RARH, 4=OAQ, 5=SPRH, 6=OACFM			SIOAI01F
DI02	Assigned DI02 Function	0=None, 1=COFS, 2=REMOCC, 3=REMOFF, 4=FILTER, 5=ENTHALPY, 6=GEN STAT, 7=HUMIDISTAT			MBBDI02F
DI04	Assigned DI04 Function	0=None, 1=COFS, 2=REMOCC, 3=REMOFF, 4=FILTER, 5=ENTHALPY, 6=GEN STAT, 7=HUMIDISTAT			MBBDI04F
DI12	Assigned DI12 Function	0=None, 1=COFS, 2=REMOCC, 3=REMOFF, 4=FILTER, 5=ENTHALPY, 6=GEN STAT, 7=HUMIDISTAT			MBBDI12F
DI13	Assigned DI13 Function	0=None, 1=COFS, 2=REMOCC, 3=REMOFF, 4=FILTER, 5=ENTHALPY, 6=GEN STAT, 7=HUMIDISTAT			MBBDI13F
DI14	Assigned DI14 Function	0=None, 1=COFS, 2=REMOCC, 3=REMOFF, 4=FILTER, 5=ENTHALPY, 6=GEN STAT, 7=HUMIDISTAT			MBBDI14F
SD04	Assigned S-DI01 Function	0=None, 1=COFS, 2=REMOCC, 3=REMOFF, 4=FILTER, 5=ENTHALPY, 6=GEN STAT, 7=HUMIDISTAT			SIODI01F
RY06	Assigned Rly 06 Function	0=None, 1=ALM Relay, 2=PE1, 3=PE2			MBBRY06F
RY11	Assigned Rly 11 Function	0=None, 1=ALM Relay, 2=PE1, 3=PE2			MBBRY11F

APPENDIX C — NAVIGATOR™ DISPLAY

Table H — MODE — RUN STATUS (cont)

ITEM	EXPANSION	RANGE	UNIT	WRITE STATUS	POINT
VERS	Versions Menu				
MODL	Equipment Model Number	xxxxxxxxxxxxxxxxxxxx			EQ_MOD
SERL	Equipment Serial Number	xxxxxxxxxx			EQ_SER
SW	Application SW Version	CESR131651-xx-xx			FW_CESR
VFD	VFD1 SW Version	text			VFD1_SW
IOB.1	SIOB1 SW Version	SIOB1 SW VERSION-x.xx			SIOB1_SW
BOOT	Bootloader Software Version	CESR131659-xx-xx			BL_CESR



APPENDIX C — NAVIGATOR™ DISPLAY

Table I — MODE – SERVICE TEST

ITEM	EXPANSION	RANGE	UNIT	POINT
SERVICE TEST				
TEST	Service Test Mode Enable	On/Off		TSTENBL
INDP	INDEPENDENT TEST MENU			
DAMP	Economizer Position Test	0 to 100	%	S_DAMPER
BMP1	Compressor Bump A1 Test	On/Off		S_BMPA1
BMP2	Compressor Bump A2 Test	On/Off		S_BMPA2
LDV.A	Liq Diverter Val Rly Tst	On/Off		S_LDV_A
RDV.A	Rht Dischg Valve Rly Tst	On/Off		S_RDV_A
RLV.A	Reheat Liq Valv Rly Test	On/Off		S_RLV_A
CLV.A	Cooling Liq Valv Test	On/Off		S_CLV_A
CCH1	Crankcase Heater 1 Test	On/Off		S_CCHR1
ALRM	Alarm Output Relay Test	On/Off		S_ALARM
PE1	Power Exhaust 1 Test	On/Off		S_PE_1
PE2	Power Exhaust 2 Test	On/Off		S_PE_2
FAN				
IDFS	Indoor Fan Speed Test	0 to 100	%	S_IDFSPD
ODFS	System ODF Speed Test	0 to 1200	rpm	S_ODFSPD
OFS1	Outdoor Fan 1 Speed Test	0 to 1200	rpm	S_ODFSP1
OFS2	Outdoor Fan 2 Speed Test	0 to 1200	rpm	S_ODFSP2
OFS3	Outdoor Fan 3 Speed Test	0 to 1200	rpm	S_ODFSP3
IF.TR	IDF Manual Transition	Yes/No		S_IDFTRN
OF.TR	ODF Manual Transition	Yes/No		S_ODFTRN
COOL				
CL.A1	Cooling W/Comp.A1 Test	On/Off		S_COOLA1
CL.A2	Cooling W/Comp.A2 Test	On/Off		S_COOLA2
CL.AL	Cooling W/Comp.ALD Test	On/Off		
IDFS	Indoor Fan Speed Test	0 to 100	%	S_IDFSPD
ODFS	System ODF Speed Test	0 to 1200	rpm	S_ODFSPD
HUM.T	HumidiMizer Level	0=Off, 1=Subcool, 2=Reheat		S_HUZLEV
HEAT				
HT.1	Heating Stage 1 Test	On/Off		S_HEAT1
HT.2	Heating Stage 2 Test	On/Off		S_HEAT2
IDFS	Indoor Fan Speed Test	0 to 100	%	S_IDFSPD

Table J — MODE – TEMPERATURES

ITEM	EXPANSION	RANGE	UNIT	WRITE STATUS	POINT
TEMPERATURES					
SAT	Supply Air Temperature	xxx.x	°F		SAT
OAT	Outdoor Air Temperature	xxx.x	°F	YES	OAT
RAT	Return Air Temperature	xxx.x	°F	YES	RAT
SPT	Space Temperature	xxx.x	°F	YES	SPACE_T
SPTO	Space Temperature Offset	xx.x	°F	YES	SPTO
SST.A	Cir.A Sat. Suction Temp	xxx.x	°F		SST_A
SDT.A	Cir.A Sat. Discharge Temp	xxx.x	°F		SDT_A
FST	Fan Supply Air Temp	xxx.x	°F		FST

Table K — MODE – PRESSURES

ITEM	EXPANSION	RANGE	UNIT	WRITE STATUS	POINT
PRESSURES					
SSP.A	Cir. A Suction Pressure	xxx.x	psig		SSP_A
SDP.A	Cir. A Discharge Pressure	xxx.x	psig		SDP_A
PR.A	Circuit A Pressure Ratio	xx.xx	n/a		CIRA_PR
BARP	Barometric Pressure	xx.xx	in. Hg	YES	BARP

APPENDIX C — NAVIGATOR™ DISPLAY

Table L — MODE – SETPOINTS

ITEM	EXPANSION	RANGE	UNIT	DEFAULT	POINT
SETPOINTS					
OCSP	Occupied Cool Setpoint	55 to 80	°F	78	OCSP
OHSP	Occupied Heat Setpoint	55 to 80	°F	68	OHSP
UCSP	Unoccupied Cool Setpoint	65 to 95	°F	85	UCSP
UHSP	Unoccupied Heat Setpoint	40 to 80	°F	60	UHSP
GAP	Heat-Cool Setpoint Gap	2 to 10	^F	5	HCSP_GAP
STO.R	SPT Offset Range (±)	0 to 5	°F	5	SPTO_RNG
RH.SP	Space RH Setpoint	0 to 100	%	55	SPRH_SP
SA.SP	SA Tempering Setpoint	xx	°F	50	SATEMPSP



APPENDIX C — NAVIGATOR™ DISPLAY

Table M — MODE – INPUTS

ITEM	EXPANSION	RANGE	UNIT	WRITE STATUS	POINT
INPUTS					
STAT	Thermostat Inputs Menu				
G	Thermostat G Input	On/Off		YES	G
Y1	Thermostat Y1 Input	On/Off		YES	Y1
Y2	Thermostat Y2 Input	On/Off		YES	Y2
Y3	Thermostat Y3 Input	On/Off		YES	Y3
W1	Thermostat W1 Input	On/Off		YES	W1
W2	Thermostat W2 Input	On/Off		YES	W2
SW	Switch Inputs Menu				
IFO	IGC Fan On Request (IFO)	On/Off			IGC_IFO
HPS.A	Cir.A High Pressure Sw	Open/Close			CIRA_HPS
HUMD	Humidistat I/P	On/Off		YES	HUMDSTAT
FDWN	Fire Shutdown Switch	Alarm/Normal		YES	FIREDOWN
COFS	COFS Switch State	High/Low		YES	COFS
FIL.S	Filter Status Switch	Dirty/Clean		YES	FILTSTAT
RM.OC	Remote Occupancy Switch	On/Off		YES	REMOCC
R.OFF	Remote Shutdown Switch	On/Off		YES	REMSHUT
GEN.S	General Status Switch	Alarm/Normal		YES	GENSTAT
ENTH	Enthalpy Switch	High/Low		YES	ENTH_SW
AIS	Analog Inputs Menu				
EC.AP	Econo Actual Position	0 to 100	%		DAMPPOS
SPRH	Space RH	0 to 100	%	YES	SPRH
OARH	OA Relative Humidity	0 to 100	%	YES	OARH
RARH	RA Relative Humidity	0 to 100	%	YES	RARH
IAQ	Indoor Air Quality Level	xxxx	ppm	YES	IAQ
OAQ	OA Quality Level	xxxx	ppm	YES	OAQ
OACFM	Outdoor Air in CFM	xxx.x	CFM	YES	OACFM
GEN	General Inputs Menu				
FT.RM	Filter hour remaining	xxxx	hours		FILTLEFT
R.FLT	Reset Filter Timer	Yes/No			RESETFLT
OAE	Outdoor Air Enthalpy	xxx.x	Btu/lb	YES	OA_ENTH
RAE	Return Air Enthalpy	xxx.x	Btu/lb	YES	RA_ENTH
DF.AQ	Differential Air Quality	xxxx	ppm		AQ_DIFF
S.VFD	Indoor Fan VFD Data				
R.HRS	IDF VFD Motor Run Hours	xxxxxxxx			VFDMHOUR
KWH.C	IDF VFD Cumulative kWh	n to 0			KWHCNTR
REF	IDF VFD Reference Speed	0 to 100			REFSPEED
SWD	IDF VFD Status Word	xxxxx			VFD1STSW
A.SPD	IDF VFD Actual Speed %	0 to 100			MAV
M.KW	IDF VFD Output Power kW	0 to 1000			OUTPWRKW
M.HP	IDF VFD Output Power hp	0 to 1000			OUTPWRHP
M.VOL	IDF VFD Output Voltage	xxxxx			OUTMVOLT
M.FQ	IDF VFD Output Freq.	xxxx.x			OUTMFREQ
M.CUR	IDF VFD Output Amps	xxx.xx			OUTMCUR
VDC	IDF VFD DC Bus Voltage	0 to 700			DCLNVOLT
HTSK	IDF VFD Heatsink Temp	-198.4 to 260.6			HTSINKT
ALM.W	IDF VFD Alarm Word	xxxxxxxx			ALMERRC
VFD.F		0=NONE, 1=PWR CARD, 2=EARTH FLT, 3=CTRL WORD, 4=OVER CURR, 5=OVER TEMP, 6=OVERLOAD, 7=UNDERVOLT, 8=OVER VOLT, 9=SHORT CIR, 10=PHASELOSS, 11=U LOSS, 12=V LOSS, 13=W LOSS, 14=CTRL VOLT, 15=VDD LOW, 16=MULTIPLE, 17=UNEXPECT			SVDFFLT

APPENDIX C — NAVIGATOR™ DISPLAY

Table M — MODE – INPUTS (cont)

ITEM	EXPANSION	RANGE	UNIT	WRITE STATUS	POINT
<i>S.VFD (cont)</i>					
VFD.W	IDF VFD Warning Detail	0=NONE, 1=VOLTAGE, 2=CURRENT, 3=THERMAL, 4=MULTIPLE, 5=UNEXPECT			SVFDWAR



APPENDIX C — NAVIGATOR™ DISPLAY

Table N — MODE – OUTPUTS

ITEM	EXPANSION	RANGE	UNIT	WRITE STATUS	POINT
OUTPUTS					
GEN	General Outputs Menu				
C.SPD	Commanded IDF Speed	0 to 100	%		FANSPEED
EC.CP	Econo Commanded Position	0 to 100	%	YES	DAMPAMD
RH.1	Liquid Dischg Valve CirA	Enable/Disable			LDV_A
RH.2	Reheat Dischg Valve CirA	Enable/Disable			RDV_A
CCH	CCH Relay 1 State	On/Off			CCHR1
PE.1	Power Exhaust 1 Relay	On/Off		YES	PE1
PE.2	Power Exhaust 2 Relay	On/Off		YES	PE2
ALRM	Alarm Output Relay State	On/Off		YES	ALMOUT
FS.HR	DD IDF high speed relay	On/Off			FSPDHRLY
FS.MR	DD IDF med. Speed relay	On/Off			FSPDMRLY
FS.LR	DD IDF low speed relay	On/Off			FSPDLRLY
COOL	Cooling Outputs Menu				
C.A1	Circuit A Compressor 1	On/Off			COMP_A1
C.A2	Circuit A Compressor 2	On/Off			COMP_A2
C.AL	Circuit A CMP A1 Loader	On/Off			COMP_ALD
ODF.S	Commanded ODF Speed	xxxx	rpm		ODFSPD
OFS1	ODF Speed Signal Output1	0 to 1200	rpm		ODF1SPD
OFS2	ODF Speed Signal Output2	0 to 1200	rpm		ODF2SPD
OFS3	ODF Speed Signal Output3	0 to 1200	rpm		ODF3SPD
HEAT	Heating Outputs Menu				
HT.1	Heat Stage 1 Relay	On/Off			HEAT_1
HT.2	Heat Stage 2 Relay	On/Off			HEAT_2

Climaproyectos
.com

APPENDIX C — NAVIGATOR™ DISPLAY

Table O — MODE – CONFIGURATIONS

ITEM	EXPANSION	RANGE	UNIT	DEFAULT	POINT
CONFIGURATION					
GEN	General Unit Config Menu				
S.DLY	Unit Startup Delay	10 to 600	sec	30	STARTDLY
U.CTL	Unit Control Type	0=TSTAT, 1=SPACE SEN, 2=RAT SEN		0=TSTAT	CTRLTYPE
T.CTL	Thermostat Hardware Type	0=CONV 2C2H, 1=DIGI 2C2H, 2=CONV 3C2H, 3=DIGI 3C2H		2=CONV 3C2H	STATTYPE
ADST	Tstat Adaptive Staging	Yes/No		Yes	ADPTSTAT
FT.TM	Change Filter Timer	0 to 9999	hours	600	FILT LIFE
T.TO	Test Inactivity Time Out	0=Disabled, 1=30 minutes, 2=1 hour, 3=2 hours, 4=4 hours, 5=8 hours, 6=12 hours		4=4 hours	TEST_ITO
FOD.C	Cooling Fan-off Delay	0 to 600	sec	75	COOL_FOD
CA.LO	Circuit A Lockout Temp	-20 to 75	°F	0: no Economizer FIOF 40: Economizer FIOF	OATLCMPA
LA.T	Low Ambient Temperature	0 to 80	°F	66	LA_TEMP
N.HTR	Number of Heating Stages	0 to 2		2 (all except below); 0 (50 series without FIOF heat) 1 (50 series, sizes 07-14 and low heat) 1 (50 series, sizes 07-12 and medium heat)	NUMHSTGS
H.FOD	Heating Fan-Off Delay	10 to 600	sec	30 (50 series) 45 (48 series)	HEAT_FOD
HT.LO	Heating Lockout Temp	40 to 125	°F	75	OATLHEAT
I.FAN	Indoor Fan Config Menu				
FS.MX	IDF Maximum Fan Speed	80 to 100		100 67 (sizes 07-12) 53 (sizes 14 or 20)	SPEEDMAX
FS.VN	Ventilation Only IDF Spd	0 to 100		56 (sizes 17) 52 (sizes 24) 60 (sizes 26) 50 (sizes 04-06)	FSPDVENT
FS.HT	Heating IDF Speed	20 to 100		100 67 (sizes 07-12) 53 (sizes 14 or 20)	FSPD_HT
FS.FC	Free Cooling IDF Speed	0 to 100		56 (sizes 17) 52 (sizes 24) 60 (sizes 26) 70 (size 04) 57 (sizes 05-06)	FSPD_FCL
FS.LC	Low Cooling IDF Speed	20 to 100		67 (sizes 07-12) 53 (sizes 14 or 20) 56 (sizes 17) 52 (sizes 24) 60 (sizes 26) 70 (size 04) 57 (sizes 05-06)	FSPD_LCL
FS.MC	Med Cooling IDF Speed	20 to 100		67 (sizes 07-12) 79 (sizes 14) 82 (sizes 17) 62 (sizes 20) 65 (sizes 24) 72 (sizes 26) 87 (sizes 04) 71 (sizes 05) 69 (sizes 06)	FSPD_MCL
FS.HC	High Cooling IDF Speed	20 to 100		100	FSPD_HCL
S.VFD	IDF VFD PARAMETERS				
N.PWR	IDF VFD Motor HP	1 to 26		See VFD Motor Default Configuration Tables. Table 35 (sizes 04-06) Table 42 (Vert. sizes 07-26) Table 43 (Horz. Sizes 07-26)	MOTPWRHP

APPENDIX C — NAVIGATOR™ DISPLAY

Table O — MODE – CONFIGURATIONS (cont)

ITEM	EXPANSION	RANGE	UNIT	DEFAULT	POINT
<i>I.FAN (cont)</i>					
N.VLT	IDF VFD Motor Volts	50 to 1000		See VFD Motor Default Configuration Tables. Table 35 (sizes 04-06) Table 42 (Vert. sizes 07-26) Table 43 (Horz. Sizes 14-26)	MOTVOLT
N.FRQ	IDF VFD Motor Freq.	20 to 400		60	MOTFREQ
N.AMP	IDF VFD Motor Current	0.1 to 40		See VFD Motor Default Configuration Tables. Table 35 (sizes 04-06) Table 42 (Vert. sizes 07-26) Table 43 (Horz. Sizes 14-26)	MOTCUR
N.RPM	IDF VFD Motor Nom. RPM	100 to 60000		See VFD Motor Default Configuration Tables. Table 35 (sizes 04-06) Table 42 (Vert. sizes 07-26) Table 43 (Horz. Sizes 14-26)	MOTNOMSP
MN.RF	IDF Danfoss Min Ref	0 to 65		0	MINREF
MX.RF	IDF Danfoss Max Ref	0 to 65		60	MAXREF
ACCL	IDF VFD Accel. Time	1 to 1800		10	RAMPUP_T
DECL	IDF VFD Decel. Time	1 to 1800		10	RAMPDN_T
MAX.A	IDF VFD Max Current	0 to 655.35		See VFD Motor Default Configuration Tables. Table 35 (sizes 04-06) Table 42 (Vert. sizes 07-26) Table 43 (Horz. Sizes 14-26)	VFD1MAXA
F.TO	IDF Danfoss Comm. TO	1 to 600		30	CNT_TOUT
R.TIM	IDF Danfoss Auto Reset	0 to 600		30	ARSTR_T
RFI	IDF Danfoss RFI Filter	On/Off		On	RFIFILTR
ECON	Economizer Config Menu				
EC.EN	Economizer Installed?	Yes/No		No: no FIOP Yes: FIOP	ECONO
EC.MX	Econ Max Damper Position	0-100	%	100	DAMPMAX
FC.MX	Free Cooling Max OAT	0 to 90	°F	65	MAXFREET
E.TRV	Economizer Travel Time	5 to 300	sec	150	ECONOTRV
MIN.P	Min Position Config Menu				
MP.MX	Econ Min at Max Fanspeed	0-100	%	30	MINP_MAX
MP.S1	Min Pos - User Speed 1	0-100	%	0	MP_USPD1
MP.D1	Min Pos - User Pos 1	0-100	%	0	MP_UPOS1
MP.S2	Min Pos - User Speed 2	0-100	%	0	MP_USPD2
MP.D2	Min Pos - User Pos 2	0-100	%	0	MP_UPOS2
MP.S3	Min Pos - User Speed 3	0-100	%	0	MP_USPD3
MP.D3	Min Pos - User Pos 3	0-100	%	0	MP_UPOS3
NET	Building Net Config Menu				
BAS	BAS Protocol Select	0=NONE, 1=CCN, 2=BACNET		0=NONE	BMS_CFG
NW.TO	Network Input Timeout	0 to 600	min	30	NETINTO
CCN	CCN Network Config Menu				
CCN.B	CCN Bus Number	0 to 239		0	CCNBUS
CCN.A	CCN Element Number	1 to 239		1	CCNADD
BAUD	CCN Baud Rate	0=9600, 1=19200, 2=38400		2	BAUDENUM
BNET	BACnet Config Menu				
MAC	BACnet Device Macaddress	1 to 127 0=9600, 1=19200, 2=38400, 3=57600, 4=76800, 5=115200		01	BAC_MAC
BAUD	BACnet BMS Baud Rate	0=9600, 1=19200, 2=38400, 3=57600, 4=76800, 5=115200		4=76800	BAC_BAUD
AUID	ALC Auto Id Scheme	Yes/No		Yes	AUID

APPENDIX C — NAVIGATOR™ DISPLAY

Table O — MODE – CONFIGURATIONS (cont)

ITEM	EXPANSION	RANGE	UNIT	DEFAULT	POINT
<i>NET (cont)</i>					
B.AID	BACnet ID Auto ID	Yes/No		Yes	BAC_AUID
ID	BACnet ID Number	0 to 4194302		1610101	BAC_ID
DISP	User Display Config Menu				
METR	Metric Display	Yes/No		No	DISPUNIT
LANG	Display Language Select	0=English		0=English	LANGUAGE
PROT	User Password Protection	Enable/Disable		Enable	PASS_EBL
PSWD	User Password	0 to 9999		1111	PASSWORD



APPENDIX C — NAVIGATOR™ DISPLAY

Table P — MODE – TIME CLOCK

ITEM	EXPANSION	RANGE	UNIT	DEFAULT	POINT
TIME CLOCK					
TIME	Clock Hour and Minute	xx:xx 1=JANUARY, 2=FEBRUARY, 3=MARCH, 4=APRIL, 5=MAY, 6=JUNE, 7=JULY, 8=AUGUST, 9=SEPTEMBER, 10=OCTOBER, 11=NOVEMBER, 12=DECEMBER	hh.mm		
MNTH	Month of Year	1=JANUARY, 2=FEBRUARY, 3=MARCH, 4=APRIL, 5=MAY, 6=JUNE, 7=JULY, 8=AUGUST, 9=SEPTEMBER, 10=OCTOBER, 11=NOVEMBER, 12=DECEMBER			MOY
DOM	Day Of Month	1 to 31			DOM
YEAR	Year	2000 to 9999			YOC_DISP
DAY	Day Of Week	1=MONDAY, 2=TUESDAY, 3=WEDNESDAY, 4=THURSDAY, 5=FRIDAY, 6=SATURDAY, 7=SUNDAY			dow
DST.A	DST Currently Active	Yes/No			DST_ACTV
DST	Daylight Savings Config DST allowed?	Enable/Disable 1=JANUARY, 2=FEBRUARY, 3=MARCH, 4=APRIL, 5=MAY, 6=JUNE, 7=JULY, 8=AUGUST, 9=SEPTEMBER, 10=OCTOBER, 11=NOVEMBER, 12=DECEMBER		Enable	DST_CFG
STR.M	DST Start Month	1=JANUARY, 2=FEBRUARY, 3=MARCH, 4=APRIL, 5=MAY, 6=JUNE, 7=JULY, 8=AUGUST, 9=SEPTEMBER, 10=OCTOBER, 11=NOVEMBER, 12=DECEMBER		3=MARCH	STARTM
STR.W	DST Start Week	1 to 5 1=MONDAY, 2=TUESDAY, 3=WEDNESDAY, 4=THURSDAY, 5=FRIDAY, 6=SATURDAY, 7=SUNDAY		2	STARTW
STR.D	DST Start Day	1=MONDAY, 2=TUESDAY, 3=WEDNESDAY, 4=THURSDAY, 5=FRIDAY, 6=SATURDAY, 7=SUNDAY		7=SUNDAY	STARTD
M.ADD	DST Minutes to Add	0 to 90 1=JANUARY, 2=FEBRUARY, 3=MARCH, 4=APRIL, 5=MAY, 6=JUNE, 7=JULY, 8=AUGUST, 9=SEPTEMBER, 10=OCTOBER, 11=NOVEMBER, 12=DECEMBER	min	60	MINADD
STP.M	DST Stop Month	1=JANUARY, 2=FEBRUARY, 3=MARCH, 4=APRIL, 5=MAY, 6=JUNE, 7=JULY, 8=AUGUST, 9=SEPTEMBER, 10=OCTOBER, 11=NOVEMBER, 12=DECEMBER		11=NOVEMBER	STOPM
STP.W	DST Stop Week	1 to 5 1=MONDAY, 2=TUESDAY, 3=WEDNESDAY, 4=THURSDAY, 5=FRIDAY, 6=SATURDAY, 7=SUNDAY		1	STOPW
STP.D	DST Stop Day	1=MONDAY, 2=TUESDAY, 3=WEDNESDAY, 4=THURSDAY, 5=FRIDAY, 6=SATURDAY, 7=SUNDAY		7=SUNDAY	STOPD
M.SUB	DST Minutes to Subtract	0 to 90	min	60	MINSUB
TOD	Time of day to start DST	0 to 600	min	120	DST_TOD
SCHD	Schedules Adjust Menu				
SCH.N	CCN Schedule Number	0 = Always Occupied, 1-64 = Local Schedule, 65-99 = Global Schedule	n/a	0	SCHEDNUM
OV.TL	Timed Override Duration	0 to 4	hours	4	OTL_CFG

APPENDIX C — NAVIGATOR™ DISPLAY

Table P — MODE – TIME CLOCK (cont)

ITEM	EXPANSION	RANGE	UNIT	DEFAULT	POINT
<i>SCHD (cont)</i>					
MON	Mon Schedule Adjust Menu				
OC.x	Monday Occupied x	00:00 to 24:00 or None	HH:MM	None	MO_OC1 - MO_OC8
UOC.x	Monday Unoccupied x	00:00 to 24:00 or None	HH:MM	None	MO_UNOC1 - MO_UNOC8
TUE	Tue Schedule Adjust Menu				
OC.x	Tuesday Occupied x	00:00 to 24:00 or None	HH:MM	None	TU_OC1 - TU_OC8
UOC.x	Tuesday Unoccupied x	00:00 to 24:00 or None	HH:MM	None	TU_UNOC1 - TU_UNOC8
WED	Wed Schedule Adjust Menu				
OC.x	Wednesday Occupied x	00:00 to 24:00 or None	HH:MM	None	WE_OC1 - WE_OC8
UOC.x	Wednesday Unoccupied x	00:00 to 24:00 or None	HH:MM	None	WE_UNOC1 - WE_UNOC8
THU	Thu Schedule Adjust Menu				
OC.x	Thursday Occupied x	00:00 to 24:00 or None	HH:MM	None	TH_OC1 - TH_OC8
UOC.x	Thursday Unoccupied x	00:00 to 24:00 or None	HH:MM	None	TH_UNOC1 - TH_UNOC8
FRI	Fri Schedule Adjust Menu				
OC.x	Friday Occupied x	00:00 to 24:00 or None	HH:MM	None	FR_OC1 - FR_OC8
UOC.x	Friday Unoccupied x	00:00 to 24:00 or None	HH:MM	None	FR_UNOC1 - FR_UNOC8
SAT	Sat Schedule Adjust Menu				
OC.x	Saturday Occupied x	00:00 to 24:00 or None	HH:MM	None	SA_OC1 - SA_OC8
UOC.x	Saturday Unoccupied x	00:00 to 24:00 or None	HH:MM	None	SA_UNOC1 - SA_UNOC8
SUN	Sun Schedule Adjust Menu				
OC.x	Sunday Occupied x	00:00 to 24:00 or None	HH:MM	None	SU_OC1 - SU_OC8
UOC.x	Sunday Unoccupied x	00:00 to 24:00 or None	HH:MM	None	SU_UNOC1 - SU_UNOC8
HOL	Hol Schedule Adjust Menu				
OC.x	Holiday Occupied x	00:00 to 24:00 or None	HH:MM	None	HD_OC1 - HD_OC8
UOC.x	Holiday Unoccupied x	00:00 to 24:00 or None	HH:MM	None	HD_UNOC1 - HD_UNOC8
<i>(repeat up to x=8 Periods)</i>					
HLDY	Holiday Adjustment Menu				
HOL.G	Accept Global Holidays?	Yes/No		No	HOLIDAYT
HL.TY	Today Is A Holiday	Yes/No			HOLTODAY
HL.TW	Tomorrow Is A Holiday	Yes/No			HOL_TMRW
HO.xx	Holiday Adjustment Menu				
LEN	Holiday Duration (days)	0 to 99		0	HD01LEN - HD30LEN
DAY	Holiday Start Day	0 to 31		0	HD01STDY - HD30STDY
MON	Holiday Start Month	0 to 12 = January to December		0	HD01STMN - HD30STMN
<i>(repeat up to xx=30 Holidays)</i>					

APPENDIX C — NAVIGATOR™ DISPLAY

Table Q — MODE – OPERATING MODES

ITEM	EXPANSION	RANGE	UNIT	WRITE STATUS	POINT
OPERATING MODES					
MODE	Operating Mode	see Appendix B			MODETEXT
SUBM	Operating Sub-Mode	see Appendix B			SUBMTEXT
S.DMD	System Demand	see Appendix B			SYS_DMDT
LINK	Linkage Active	Yes/No		Yes	LNK_ACT
EFF.C	Cool Setpoint In Effect	xx.x	°F		CSP_EFF
EFF.H	Heat Setpoint In Effect	xx.x	°F		HSP_EFF
T.EFF	Effective Demand Temp	xxx.x	°F		TEMP_EFF
CLTG	Cool Mode Select T.guard	xxx	sec		COOLMSTG
HTTG	Heat Mode Select T.guard	xxx	sec		HEATMSTG

Table R — MODE – ALARMS

ITEM	EXPANSION	RANGE	WRITE STATUS	POINT
ALARMS				
CURR alarm# (repeat up to 25 times)	Curr Active Alarm Menu text string			ALARM01C - ALARM25C
HIST alarm# (repeat up to 50 times)	History Menu alarm# - mm/dd/yy-hh.mm-text string			ALHIS001 - ALHIS050
R.CUR R.HIS ARxx (repeat up to 20 times)	Reset All Current Alarms Alarm Reset History Menu mm/dd/yy, hh:mm:ss	Yes/No	Yes	ALRESET ALMRES00 - ALMRES19

Climaproyectos
.com

APPENDIX D — SYSTEMVU™ CONTROLLER CCN TABLES

Table S — Status Display Tables

TABLE	DISPLAY NAME	RANGE	UNITS	POINT NAME	WRITE STATUS
	Supply Air Temperature	xxx.x	°F	SAT	
	Outdoor Air Temperature	xxx.x	°F	OAT	Forcible
	Return Air Temperature	xxx.x	°F	RAT	Forcible
	Space Temperature	xxx.x	°F	SPACE_T	Forcible
	Space Temperature Offset	XX.X	°F	SPTO	Forcible
	Fan Supply Air Temp	xxx.x	°F	FST	
	Cir.A Sat.Suction Temp	xxx.x	°F	SST_A	
	Cir.A Sat.Discharge Temp	xxx.x	°F	SDT_A	
	Cir.A Suction Pressure	xxx.x	psig	SSP_A	
	Cir.A Discharge Pressure	xxx.x	psig	SDP_A	
	Thermostat G Input	On/Off		G	Forcible
	Thermostat Y1 Input	On/Off		Y1	Forcible
	Thermostat Y2 Input	On/Off		Y2	Forcible
	Thermostat Y3 Input	On/Off		Y3	Forcible
	Thermostat W1 Input	On/Off		W1	Forcible
	Thermostat W2 Input	On/Off		W2	Forcible
	Humidistat I/P	On/Off		HUMDSTAT	Forcible
	IGC Fan On Request (IFO)	On/Off		IGC_IFO	
	Cir.A High Pressure Sw	Open/Close		CIRA_HPS	
	Fire Shutdown Switch	Alarm/Normal		FIREDOWN	Forcible
	COFS Switch State	High/Low		COFS	Forcible
	Filter Status Switch	Dirty/Clean		FILTSTAT	Forcible
	Remote Occupancy Switch	On/Off		REMOCC	Forcible
	Remote Shutdown Switch	On/Off		REMSHUT	Forcible
	General Status Switch	Alarm/Normal		GENSTAT	Forcible
	Enthalpy Switch	High/Low		ENTH_SW	Forcible
	Econo Actual Position	0 to 100	%	DAMPPOS	Forcible
	OA Relative Humidity	0 to 100	%	OARH	Forcible
	RA Relative Humidity	0 to 100	%	RARH	Forcible
	Indoor Air Quality Level	xxxx	ppm	IAQ	Forcible
	OA Quality Level	xxxx	ppm	OAQ	Forcible
	Space RH	0 to 100	%	SPRH	Forcible
	Outdoor Air in CFM	xxxx	cfm	OACFM	Forcible
	Commanded IDF Speed	0 to 100	%	FANSPEED	
	Econo Commanded Position	0 to 100	%	DAMPCMD	Forcible
	CCH Relay 1 State	On/Off		CCHR1	
	Power Exhaust 1 Relay	On/Off		PE1	Forcible
	Power Exhaust 2 Relay	On/Off		PE2	Forcible
	Alarm Output Relay State	On/Off		ALMOUT	Forcible
	Circuit A Compressor 1	On/Off		COMP_A1	
	Circuit A Compressor 2	On/Off		COMP_A2	
	Circuit A CMP A1 Loader	On/Off		COMP_ALD	
	Commanded ODF Speed	xxxx	rpm	ODFSPD	
	ODF Speed Signal Output1	xxxx	rpm	ODF1SPD	
	ODF Speed Signal Output2	xxxx	rpm	ODF2SPD	
	ODF Speed Signal Output3	xxxx	rpm	ODF3SPD	
	Heat Stage 1 Relay	On/Off		HEAT_1	
	Heat Stage 2 Relay	On/Off		HEAT_2	
	Liquid Diverter Val CirA	Enable/Disable		LDV_A	
	Reheat Dischg Valve CirA	Enable/Disable		RDV_A	
	Reheat Liquid Valve CirA	Enable/Disable		RLV_A	
	Cooling Liq Valve CirA	Enable/Disable		CLV_A	
	DD IDF High Speed Relay	On/Off		FSPDHRLY	
	DD IDF Medium Speed Relay	On/Off		FSPDMRLY	
	DD IDF Low Speed Relay	On/Off		FSPDLRLY	

UINPUT

UOUTPUT

APPENDIX D — SYSTEMVU™ CONTROLLER CCN TABLES

Table S — Status Display Tables (cont)

TABLE	DISPLAY NAME	RANGE	UNITS	POINT NAME	WRITE STATUS	
GENDISP	Circuit A Pressure Ratio	xx.xx		CIRA_PR		
	Barometric Pressure	xx.xx	in.Hg	BARP	Forcible	
	Filter hour remaining	xxxx	hours	FILTLEFT		
	Reset Filter Timer	Yes/No		RESETFLT	Writable	
	Outdoor Air Enthalpy	xxx.x	Btu/lb	OA_ENTH	Forcible	
	Return Air Enthalpy	xxx.x	Btu/lb	RA_ENTH	Forcible	
	Differential Air Quality	xxxx	ppm	AQ_DIFF		
	DST currently active	Yes/No		DST_ACTV		
	Network OAT Value	xxx.x	°F	OAT_NET	Forcible	
	Network Return Air Temp	xxx.x	°F	RAT_NET	Forcible	
	Network Space Temp Value	xxx.x	°F	SPT_NET	Forcible	
	Network SPRH Value	0 to 100	%	SPRH_NET	Forcible	
	Network OARH Value	0 to 100	%	OARH_NET	Forcible	
	Network RARH Value	0 to 100	%	RARH_NET	Forcible	
	Network IAQ Value	xxxx	ppm	IAQ_NET	Forcible	
	Network OAQ Value	xxxx	ppm	OAQ_NET	Forcible	
	Network OACFM Value	xxx.x	cfm	OCFM_NET	Forcible	
	MODEDISP	System Mode	see Appendix B		SYSMODE	
Running Mode Operation		see Appendix B		SUB_MODE		
Ventilation Status		see Appendix B		VENTSTAT		
System Demand		0 to 99		SYS_DMD		
Currently Occupied		Yes/No		OCCUPIED	Forcible	
Linkage Active		Yes/No		LNK_ACT	Forcible	
Unocc Free Cool Active		Yes/No		UFC_ACT		
Temp Compensate Start On		Yes/No		TCS_ACT		
Cool Setpoint In Effect		xx.x	°F	CSP_EFF		
Heat Setpoint In Effect		xx.x	°F	HSP_EFF		
Effective Demand Temp		xxx.x	°F	TEMP_EFF		
Cool Demand Limiting Off		0 to 1		CDMLMOFF		
Cool Demand Limit Offset		0 to 99	°F	COOLDLMO		
Heat Demand Limiting Off		0 to 1		HDMLMOFF		
Heat Demand Limit Offset		0 to 99	°F	HEATDLMO		
Cool Demand Limit Level		0 to 3		CDMDLLEV		
Heat Demand Limit Level		0 to 3		HDMDLLEV		
IDF_DISP		Commanded IDF Speed	0 to 100	%	FANSPEED	
	IDF VFD Actual Speed %	0 to 100	%	MAV		
	IDF Speed Override Flag	On/Off		FAN_OVRD		
	IDF Operation Errors?	Yes/No		IDFBAD		
	IDF Speed Reduction On	Yes/No		FANRED10		
	IDF VFD Output Amps	0 to 655.35	Amps	OUTMCUR		
	IDF VFD Output Power hp	0 to 1000		OUTPWRHP		
	IDF VFD Fault Detail	0=NONE, 1=PWR CARD, 2=EARTH FLT, 3=CTRL WORD, 4=OVER CURR, 5=OVER TEMP, 6=OVERLOAD, 7=UNDERVOLT, 8=OVER VOLT, 9=SHORT CIR, 10=PHASELOSS, 11=U LOSS, 12=V LOSS, 13=W LOSS, 14=CTRL VOLT, 15=VDD LOW, 16=MULTIPLE, 17=UNEXPECT			SVFDFLT	
	IDF VFD Warning Detail	0=NONE, 1=VOLTAGE, 2=CURRENT, 3=THERMAL, 4=MULTIPLE, 5=UNEXPECT			SVFDWAR	

APPENDIX D — SYSTEMVU™ CONTROLLER CCN TABLES

Table S — Status Display Tables (cont)

TABLE	DISPLAY NAME	RANGE	UNITS	POINT NAME	WRITE STATUS
COOLDISP	OK to Use Free Cooling?	Yes/No		OKFREECL	
	Free Cooling Active	Yes/No		FREECOOL	
	Free Cooling SAT Setpnt	xx.x	°F	FC_SATSP	
	Econo Commanded Position	0 to 100	%	DAMPCMD	Forcible
	Commanded IDF Speed	0 to 100	%	FANSPEED	
	Ok to use compressors?	Yes/No		OKMECHCL	
	Mechanical Cool active?	Yes/No		MECHCOOL	
	Max Allowed Cool Stages	0 to 3		MAXCSTGS	
	Requested Cooling Stages	0 to 3		REQCSTGS	
	Actual Cool Stage Active	x		ACTCSTGS	
	Circuit A Compressor 1	On/Off		COMP_A1	
	Circuit A Compressor 2	On/Off		COMP_A2	
	Circuit A CMP A1 Loader	On/Off		COMP_ALD	
	Compressor A1 Timeguard	xxx	sec	TIMGD_A1	
	Compressor A2 Timeguard	xxx	sec	TIMGD_A2	
	cmp Loader Timeguard	xxx	sec	TIMG_ALD	
	Commanded ODF Speed	xxxx	rpm	ODFSPD	
	OK to use humidizer	Yes/No		OKTOHUMZ	
	Requested Dehum Level	0 to 2		REQDHLEV	
	Req Compr Dehum Stgs	0 to 3	rpm	REQDSTGS	
	Cir.A Sat.Discharge Temp	xxx.x	°F	SDT_A	
	Cir.A Sat.Suction Temp	xxx.x	°F	SST_A	
	Cir.A Discharge Pressure	xxx.x	psig	SDP_A	
	Cir.A Suction Pressure	xxx.x	psig	SSP_A	
	Circuit A Pressure Ratio	xx.xx		CIRA_PR	
	Cir.A High Pressure Sw	Open/Close		CIRA_HPS	
	Supply Air Temperature	xxx.x	°F	SAT	
Outdoor Air Temperature	xxx.x	°F	OAT	Forcible	
HEATDISP	OK to Run Heat	Yes/No		OKTOHEAT	
	OK to Supply Air Tempering	Yes/No		OKTOTEMP	
	IGC Fan On Request (IFO)	On/Off		IGC_IFO	
	Commanded IDF Speed	0 to 100	%	FANSPEED	
	Max Allowed Heat Stages	0 to 2		MAXHSTGS	Forcible
	Requested Heating Stages	0 to 2		REQHSTGS	
	Actual Heat Stage Active	x		ACTHSTGS	
	Heat Stage 1 Relay	On/Off		HEAT_1	
	Heat Stage 2 Relay	On/Off		HEAT_2	
	Heat Stage 1 Timeguard	xxx	sec	TIMGD_H1	
	Heat Stage 2 Timeguard	xxx	sec	TIMGD_H2	
	VENTDISP	Ventilation Status	see Appendix B		VENTSTAT
Ventilation Status		see Appendix B		VENTTEXT	
Min Position in Effect		0 to 100	%	MIN_POS	Forcible
In Pre-Occupancy Purge?		Yes/No		PREOCCON	
Differential Air Quality		xxxx	ppm	AQ_DIFF	
Commanded IDF Speed		0 to 100	%	FANSPEED	
Econo Commanded Position		0 to 100	%	DAMPCMD	Forcible
Econo Actual Position		0 to 100	%	DAMPPOS	Forcible
Free Cooling active		Yes/No		FREECOOL	
Currently Occupied		Yes/No		OCCUPIED	Forcible
Mins until next occupied		xxxxx	min	MINTILOC	
Ok to Preoccupancy Purge		Yes/No		OKPREOCC	
Power Exhaust 1 Relay	On/Off		PE1	Forcible	
Power Exhaust 2 Relay	On/Off		PE2	Forcible	
ALRMDISP	Active Alarm 1 Code	xxx		ALMCODE1	
	Active Alarm 2 Code	xxx		ALMCODE2	
	Active Alarm 3 Code	xxx		ALMCODE3	
	Active Alarm 4 Code	xxx		ALMCODE4	
	Active Alarm 5 Code	xxx		ALMCODE5	
	Reset All Current Alarms	Yes/No		ALRESET	Writable

APPENDIX D — SYSTEMVU™ CONTROLLER CCN TABLES

Table S — Status Display Tables (cont)

TABLE	DISPLAY NAME	RANGE	UNITS	POINT NAME	WRITE STATUS
STRTHOUR	Compressor A1 Run Hours	xxxxxx.x	hours	HR_A1	
	Compressor A2 Run Hours	xxxxxx.x	hours	HR_A2	
	CMP A1 Loader Run Hours	xxxxxx.x	hours	HR_ALDR	
	Alarm Relay Run Hours	xxxxxx.x	hours	HR_ALM	
	CCH1 Relay Run Hours	xxxxxx.x	hours	HR_CCHR1	
	Econ Damper Run Hours	xxxxxx.x	hours	HR_DAMP	
	Unit Full Load Run Hours	xxxxxx.x	hours	HR_FLOAD	
	Free Cooling Run Hours	xxxxxx.x	hours	HR_FREEC	
	Heat Stage 1 Run Hours	xxxxxx.x	hours	HR_HTR_1	
	Heat Stage 2 Run Hours	xxxxxx.x	hours	HR_HTR_2	
	LDV_A Run Hours	xxxxxx.x	hours	HR_LDV_A	
	Indoor Fan Run Hours	xxxxxx.x	hours	HR_IDF	
	Max Fan Speed Run Hours	xxxxxx.x	hours	HR_MAXF	
	ODF Spd Sig 1 Run Hours	xxxxxx.x	hours	HR_ODF1	
	ODF Spd Sig 2 Run Hours	xxxxxx.x	hours	HR_ODF2	
	ODF Spd Sig 3 Run Hours	xxxxxx.x	hours	HR_ODF3	
	RDV_A Run Hours	xxxxxx.x	hours	HR_RDV_A	
	Reheat level 1 Run Hrs	xxxxxx.x	hours	HR_RQHL1	
	Reheat level 2 Run Hrs	xxxxxx.x	hours	HR_RQHL2	
	Power Exhaust1 Run Hours	xxxxxx.x	hours	HR_PE_1	
Power Exhaust2 Run Hours	xxxxxx.x	hours	HR_PE_2		
Service Test Run Hours	xxxxxx.x	hours	HR_STEST		
Vent IDF Run Hours	xxxxxx.x	hours	HR_VENTF		
STRCNTS	Compressor A1 Starts	xxxxxx		ST_A1	
	Compressor A2 Starts	xxxxxx		ST_A2	
	CMP A1 Loader Starts	xxxxxx		ST_ALDR	
	Alarm Relay Starts	xxxxxx		ST_ALM	
	Alarm Reset Counts	xxxxxx		ST_ALRST	
	CCH1 Relay Starts	xxxxxx		ST_CCHR1	
	Economizer Damper Starts	xxxxxx		ST_DAMP	
	Unit Full Load Starts	xxxxxx		ST_FLOAD	
	Free Cooling Starts	xxxxxx		ST_FREEC	
	Heat Stage 1 Starts	xxxxxx		ST_HTR_1	
	Heat Stage 2 Starts	xxxxxx		ST_HTR_2	
	Indoor Fan Starts	xxxxxx		ST_IDF	
	LDV_A Starts	xxxxxx		ST_LDV_A	
	Max IDF Speed Starts	xxxxxx		ST_MAXF	
	ODF Spd Signal 1 Starts	xxxxxx		ST_ODF1	
	ODF Spd Signal 2 Starts	xxxxxx		ST_ODF2	
	ODF Spd Signal 3 Starts	xxxxxx		ST_ODF3	
	Power Exhaust 1 Starts	xxxxxx		ST_PE_1	
	Power Exhaust 2 Starts	xxxxxx		ST_PE_2	
	Power Cycle Counts	xxxxxx		ST_POR	
RDV_A Starts	xxxxxx		ST_RDV_A		
Reheat level 1 Starts	xxxxxx		ST_RQHL1		
Reheat level 2 Starts	xxxxxx		ST_RQHL2		
Service Test Starts	xxxxxx		ST_STEST		
Ventilation Fan Starts	xxxxxx		ST_VENTF		

APPENDIX D — SYSTEMVU™ CONTROLLER CCN TABLES

Table S — Status Display Tables (cont)

TABLE	DISPLAY NAME	RANGE	UNITS	POINT NAME	WRITE STATUS
STRTRSTS	Comp A1 Resets Count	xxxxxx		RS_A1	
	Comp A2 Resets Count	xxxxxx		RS_A2	
	A1 Loader Resets Count	xxxxxx		RS_ALDR	
	Alarm Relay Resets Count	xxxxxx		RS_ALM	
	Alarm Reset Resets Count	xxxxxx		RS_ALRST	
	CCH1 Relay Resets Count	xxxxxx		RS_CCHR1	
	Econ Damper Resets Count	xxxxxx		RS_DAMP	
	Full Load Resets Count	xxxxxx		RS_FLOAD	
	Free Cooling Reset Count	xxxxxx		RS_FREEC	
	Heat Stage 1 Reset Count	xxxxxx		RS_HTR_1	
	Heat Stage 2 Reset Count	xxxxxx		RS_HTR_2	
	Indoor Fan Reset Count	xxxxxx		RS_IDF	
	ldv_a Resets Count	xxxxxx		RS_LDV_A	
	Max IDF Spd Resets Count	xxxxxx		RS_MAXF	
	ODF Signal1 Resets Count	xxxxxx		RS_ODF1	
	ODF Signal2 Resets Count	xxxxxx		RS_ODF2	
	ODF Signal3 Resets Count	xxxxxx		RS_ODF3	
	P.Exhaust 1 Resets Count	xxxxxx		RS_PE_1	
	P.Exhaust 2 Resets Count	xxxxxx		RS_PE_2	
	Power Cycle Resets Count	xxxxxx		RS_POR	
	rdv_a Resets Count	xxxxxx		RS_RDV_A	
	Reheat Lev 1 Rst Count	xxxxxx		RS_RQHL1	
	Reheat Lev 2 Rst Count	xxxxxx		RS_RQHL2	
Service Test Reset Count	xxxxxx		RS_STEST		
Vent IDF Resets Count	xxxxxx		RS_VENTF		

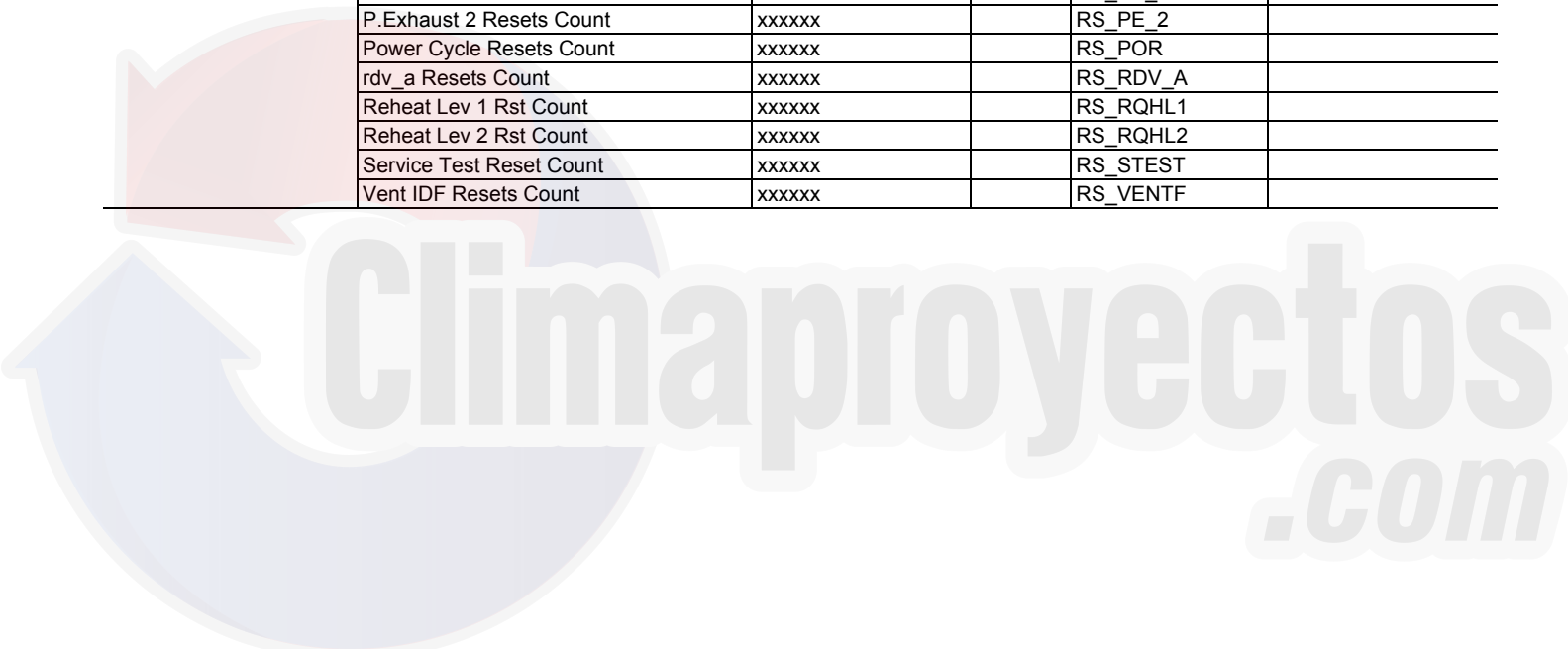

APPENDIX D — SYSTEMVU™ CONTROLLER CCN TABLES

Table T — MAINTENANCE TABLES

TABLE	DISPLAY NAME	RANGE	UNITS	POINT NAME	WRITE STATUS	
MODES	Operating Mode	see Appendix B		MODETEXT		
	System Mode	see Appendix B		SYSMODE		
	Operating Sub-Mode	see Appendix B		SUBMTEXT		
	Running Mode Operation	see Appendix B		SUB_MODE		
	Ventilation Status	see Appendix B		VENTTEXT		
	Ventilation Status	see Appendix B		VENTSTAT		
	System Demand	see Appendix B		SYS_DMDT		
	System Demand	0 to 99		SYS_DMD		
	Currently Occupied	Yes/No		OCCUPIED	Forcible	
	Linkage Active	Yes/No		LNK_ACT	Forcible	
	Unocc Free Cool Active	Yes/No		UFC_ACT		
	Temp Compensate Start On	Yes/No		TCS_ACT		
	Current Mode Ended	Yes/No		MODEDONE		
	Cool Mode Select T.guard	xxx		sec	COOLMSTG	
	Heat Mode Select T.guard	xxx		sec	HEATMSTG	
	Cool Setpoint In Effect	xx.x		°F	CSP_EFF	
	Heat Setpoint In Effect	xx.x		°F	HSP_EFF	
	Effective Demand Temp	xxx.x		°F	TEMP_EFF	
	Space Cooling Demand	xx.x		°F	COOL_DMD	
	Cooling Demand Trend	xx.x		°F/min	CLDTREND	
	Heating Space Demand	xx.x		°F	HEAT_DMD	
	Heat Space Demand Trend	xx.x		°F/min	HTDTREND	
	Economizer Position Test	0 to 100		%	S_DAMPER	
	Compressor Bump A1 Test	On/Off			S_BMPA1	
	Compressor Bump A2 Test	On/Off			S_BMPA2	
Cmp Bump Loader Test	On/Off			S_BMPALD		
Liq Diverter Val Rly Tst	On/Off			S_LDV_A		
Rht Dischg Valve Rly Tst	On/Off			S_RDV_A		
Reheat Liq Valv Rly Test	On/Off			S_RLV_A		
Cooling Liq Valv Test	On/Off			S_CLV_A		
Crankcase Heater 1 Test	On/Off			S_CCHR1		
Alarm Output Relay Test	On/Off			S_ALARM		
Power Exhaust 1 Test	On/Off			S_PE_1		
Power Exhaust 2 Test	On/Off			S_PE_2		
Indoor Fan Speed Test	0 to 100		%	S_IDFSPD		
System ODF Speed Test	0 to 1200		rpm	S_ODFSPD		
Outdoor Fan 1 Speed Test	0 to 1200		rpm	S_ODFSP1		
Outdoor Fan 2 Speed Test	0 to 1200		rpm	S_ODFSP2		
Outdoor Fan 3 Speed Test	0 to 1200		rpm	S_ODFSP3		
IDF Manual Transition	Yes/No			S_IDFTRN		
ODF Manual Transition	Yes/No			S_ODFTRN		
Cooling W/Comp.A1 Test	On/Off			S_COOLA1		
Cooling W/Comp.A2 Test	On/Off			S_COOLA2		
Cooling W/Comp.ALD Test	On/Off			S_COLALD		
Humidifier Level	0=Off, 1=Subcool, 2=Reheat			S_HMZLEV		
Heating Stage 1 Test	On/Off			S_HEAT1		
Heating Stage 2 Test	On/Off			S_HEAT2		
AUTO INDEPENDENT TEST	Yes/No			AUTOINDP		
RUN AUTO COOLING TEST	Yes/No			AUTOCOOL		
RUN AUTO HEATING TEST	Yes/No			AUTOHEAT		
RUN AUTO SYSTEM TEST	Yes/No			AUTOSYS		

APPENDIX D — SYSTEMVU™ CONTROLLER CCN TABLES

Table T — MAINTENANCE TABLES (cont)

TABLE	DISPLAY NAME	RANGE	UNITS	POINT NAME	WRITE STATUS	
IDF_DIAG	Commanded IDF Speed	0 to 100	%	FANSPEED		
	IDF VFD Actual Speed %	0 to 100	%	MAV		
	Requested IDF Speed	0 to 100	%	RQFANSPPD		
	IDF Speed Override Flag	On/Off		FAN_OVRD		
	IDF Speed Reduction On	Yes/No		FANRED10		
	IDF Operation Errors?	Yes/No		IDFBAD		
	IDF VFD Fault Detail	0=NONE, 1=PWR CARD, 2=EARTH FLT, 3=CTRL WORD, 4=OVER CURR, 5=OVER TEMP, 6=OVERLOAD, 7=UNDERVOLT, 8=OVER VOLT, 9=SHORT CIR, 10=PHASELOSS, 11=U LOSS, 12=V LOSS, 13=W LOSS, 14=CTRL VOLT, 15=VDD LOW, 16=MULTIPLE, 17=UNEXPECT			SVFDFLT	
	IDF VFD Warning Detail	0=NONE, 1=VOLTAGE, 2=CURRENT, 3=THERMAL, 4=MULTIPLE, 5=UNEXPECT			SVFDWAR	
	IDF VFD Motor Run Hours	xxxxxxxx	hours	VFDMHOUR		
	IDF VFD Cumulative kWh	n to 0	kWh	KWHCNTR		
	IDF VFD Alarm Word	xxxxxxxx		ALMERRC		
	IDF VFD Reference Speed	0 to 100	%	REFSPEED		
	IDF VFD Output Power kW	0 to 1000	kW	OUTPWRKW		
	IDF VFD Output Power hp	0 to 1000		OUTPWRHP		
	IDF VFD Output Voltage	0 to 65535	volts	OUTMVOLT		
	IDF VFD Output Freq.	0 to 6553.5	Hz	OUTMFREQ		
	IDF VFD Output Amps	0 to 655.35	Amps	OUTMCUR		
	IDF VFD DC Bus Voltage	0 to 700	volts	DCLNVOLT		
	IDF VFD Heatsink Temp	-198.4 to 260.6	°F	HTSINKT		
	IDF VFD Status Word	xxxxx		VFD1STSW		
USB_DIAG	USB TREND STATUS	0=IDLE, 1=TRENDING, 2=NO POINTS, 3=USB FULL		TRNDSTAT		
	USB TREND DURATION	0=1 MINUTE, 1=5 MINUTES, 2=15 MINUTES, 3=30 MINUTES, 4=1 HOUR, 5=3 HOURS, 6=8 HOURS, 7=12 HOURS, 8=1 DAYS, 9=1.5 DAYS, 10=2 DAYS, 11=3 DAYS, 12=5 DAYS, 13=1 WEEK, 14=2 WEEK, 15=4 WEEK, 16=USB FULL		TRNDDUR	Yes	
	USB TREND RATE	1 to 300		TRNDRATE	Yes	
	USB TREND POINTS FROM	0=FILE, 1=LIST		TRNDPNTS	Yes	
	TREND FILE SEARCH	text string		TRNDFILE		
	TREND EQUIP PERFORMANCE	On/Off		TRNDEQPR	Yes	
	TREND COOL PERFORMANCE	On/Off		TRNDCCLR	Yes	
	TREND HEAT PERFORMANCE	On/Off		TRNDHTPR	Yes	
	TREND COOLING DIAGNOSTIC	On/Off		TRNDCLDG	Yes	
	TREND IDF DIAGNOSTIC	On/Off		TRNDIDF	Yes	

APPENDIX D — SYSTEMVU™ CONTROLLER CCN TABLES

Table T — MAINTENANCE TABLES (cont)

TABLE	DISPLAY NAME	RANGE	UNITS	POINT NAME	WRITE STATUS
USB_DIAG (cont)	TREND VENTILATION	On/Off		TRNDVENT	Yes
	TREND GEN INPUTS/OUTPUTS	On/Off		TRNDIO	Yes
	Start USB Trending	Yes/No		TREND_EN	
	Make Config Backup File	Start/Stop		DDBCKUP	Yes
	Backup File is ready	0=IDLE, 1=SUCCESS, 2=FAILURE		BACKUP_R	
	USB Find Restore File	Yes/No		BACKFILE	Yes
	Start Config Restore	Start/Stop		DDRSTRE	Yes
	File Error	Yes/No		FILE_ERR	
COOLDIAG	System Demand	see Appendix B		SYS_DMDT	
	Operating Sub-Mode	see Appendix B		SUBMTEXT	
	Requested IDF Speed	0 to 100	%	RQFANSPD	
	Commanded IDF Speed	0 to 100	%	FANSPEED	
	IDF Commanded RPM		rpm	FSPD_RPM	
	OK to Use Free Cooling?	Yes/No		OKFREECL	
	Econ Damper Operational	Yes/No		DAMPGOOD	
	Dry Bulb Lockout	Yes/No		DBLOCK	Forcible
	Enthalpy Lockout	Yes/No		ENTHLOCK	Forcible
	Free Cooling Active	Yes/No		FREECOOL	
	Unocc Free Cool Active	Yes/No		UFC_ACT	
	Free Cooling SAT Setpnt	xx.x	°F	FC_SATSP	
	Requested Damper Pos	0 to 100	%	REQDAMP	
	Econo Commanded Position	0 to 100	%	DAMPCMD	Forcible
	Ok to use compressors?	Yes/No		OKMECHCL	
	Compressor A1 Strikes	x		A1STRIKE	
	Compressor A2 Strikes	x		A2STRIKE	
	Circuit A Locked Out	Yes/No		CIRALOCK	
	Mechanical Cool Active?	Yes/No		MECHCOOL	
	Max Allowed Cool Stages	0 to 3		MAXCSTGS	Forcible
	Number of Cooling Stages	0 to 3		NUMCSTGS	
	Supply Air Temp Trend	xxx.x	°F/min	SATTREND	
	Supply Air Temperature	xxx.x	°F	SAT	
	Requested Cooling Stages	0 to 3		REQCSTGS	
	Low Cooling Locked Out	Yes/No		LC_LOCK	
	Medium Cooling Lockout	Yes/No		MC_LOCK	
	Compressor A1 Timeguard	xxx	sec	TIMGD_A1	
	Compressor A2 Timeguard	xxx	sec	TIMGD_A2	
	cmp Loader Timeguard	xxx	sec	TIMG_ALD	
	Compressor A1 locked out	Yes/No		CA1_LOCK	
	Compressor A2 locked out	Yes/No		CA2_LOCK	
	Compressor A1 Available	Yes/No		CA1_AVAL	
	Compressor A2 Available	Yes/No		CA2_AVAL	
	Recent Comp A1 Strike	Yes/No		A1STKACT	
	Recent Comp A2 Strike	Yes/No		A2STKACT	
	Circuit A Compressor 1	On/Off		COMP_A1	
	Circuit A Compressor 2	On/Off		COMP_A2	
	Circuit A CMP A1 Loader	On/Off		COMP_ALD	
	Actual Cool Stage Active	x		ACTCSTGS	
	Humidimizer Lockout Temp	-20 to 75	°F	OATLHUMZ	
Req Compr Dehum Stgs	0 to 3		REQDSTGS		
High Pressure Override	Yes/No		HP_OVR		
ODF Speed Signal Output1	0 to 1200	rpm	ODF1SPD		
ODF Speed Signal Output2	0 to 1200	rpm	ODF2SPD		
ODF Speed Signal Output3	0 to 1200	rpm	ODF3SPD		

APPENDIX D — SYSTEMVU™ CONTROLLER CCN TABLES

Table T — MAINTENANCE TABLES (cont)

TABLE	DISPLAY NAME	RANGE	UNITS	POINT NAME	WRITE STATUS
COOLDIAG (cont)	ODF Control SDT SP	0	°F	ODFSDTSP	
	Low Ambient Ctrl Status	0=Normal, 1=Entering, 2=Low Ambient, 3=Exiting		LACTRLST	
	Outdoor Air Temperature	xxx.x	°F	OAT	Forcible
	Cir.A High Pressure Sw	Open/Close		CIRA_HPS	
	Cir.A Discharge Pressure	xxx.x	psig	SDP_A	
	Cir.A Suction Pressure	xxx.x	psig	SSP_A	
	Circuit A Pressure Ratio	xx.xx		CIRA_PR	
	Cir.A Sat.Discharge Temp	xxx.x	°F	SDT_A	
Cir.A Sat.Suction Temp	xxx.x	°F	SST_A		
HUMZDIAG	Ok to Dehumidify?	Yes/No		OKTODHUM	
	Requested Dehum Level	0 to 2		REQDHLEV	
	Ok to Use Humidimizer	Yes/No		OKTOHUMZ	
	Liquid Dischg Valve CirA	Enable/Disable		LDV_A	
	Reheat Dischg Valve CirA	Enable/Disable		RDV_A	
	Reheat Liquid Valve CirA	Enable/Disable		RLV_A	
	Cooling Liq Valve CirA	Enable/Disable		CLV_A	
	Fan Based Dehum Type	0=None, 1=Comfort, 2=Max		FBD_TYPE	
	FBDH SAT Min value	35 to 80	°F	FBDH_SAT	
	FBDH Max Mode SST SP	20 to 60	°F	FBDSSSTSP	
	FBDH SST Min value	10 to 60	°F	FBDH_SST	
	FBDH Low Setpoint	-20 to 0	°F delta	FBDLO_SP	
	Requested IDF Speed	0 to 200	%	RQFANSPD	
	Ok to Fan Based Dehum	Yes/No		OKTOFBD	
FBDH SST Locked Out	Yes/No		FBDSSSTLO		
FBDH SAT Lockout	Yes/No		FBDSATLO		
OKFCDIAG	Outdoor Air Temperature	xxx.x	°F	OAT	Forcible
	OA Relative Humidity	0 to 100	%	OARH	Forcible
	Outdoor Air Enthalpy	xxx.x	Btu/lb	OA_ENTH	Forcible
	Return Air Temperature	xxx.x	°F	RAT	Forcible
	RA Relative Humidity	0 to 100	%	RARH	Forcible
	Return Air Enthalpy	xxx.x	Btu/lb	RA_ENTH	Forcible
	Barometric Pressure	xx.xx	in.Hg	BARP	Forcible
	Diff. Dry Bulb Control	Enable/Disable		DIFFBULB	
	Free Cooling Min Temp	-30 to 70	°F	MINFREET	
	Free Cooling Max OAT	0 to 90	°F	MAXFREET	
	Diff. Dry Bulb Deadband	0 to 20	°F	OATRATDB	
	Dry Bulb Lockout	Yes/No		DBLOCK	Forcible
	Diff. Enthalpy Control	Enable/Disable		DIFFENTH	
	Max Enthalpy OA Limit	1 to 99	Btu/lb	FREEMAXE	
	Enthalpy Cross Deadband	0 to 20	Btu/lb	OAERAEDB	
	Enthalpy Switch	High/Low		ENTH_SW	Forcible
	Enthalpy Lockout	Yes/No		ENTHLOCK	Forcible
	Currently Occupied	Yes/No		OCCUPIED	Forcible
	Unocc Free Cool Low Temp	-30 to 70	°F	OATLUFC	
	Unocc Free Cool Lockout	Yes/No		UNOCLOCK	
	Econ Damper Operational	Yes/No		DAMPGOOD	
	OK to Use Free Cooling?	Yes/No		OKFREECL	
Ok to Unocc Free Cool?	Yes/No		OKTOUFC		

APPENDIX D — SYSTEMVU™ CONTROLLER CCN TABLES

Table T — MAINTENANCE TABLES (cont)

TABLE	DISPLAY NAME	RANGE	UNITS	POINT NAME	WRITE STATUS
HEATDIAG	System Demand	see Appendix B		SYS_DMDT	
	Operating Sub-Mode	see Appendix B		SUBMTEXT	
	IGC Fan On Request (IFO)	On/Off		IGC_IFO	
	Requested IDF Speed	0 to 100	%	RQFANSPD	
	Commanded IDF Speed	0 to 100	%	FANSPEED	
	OK to Run Heat	Yes/No		OKTOHEAT	
	All Heat Stages Lockout	Yes/No		ALLHTLOC	Forcible
	Max Allowed Heat Stages	0 to 2		MAXHSTGS	Forcible
	Supply Air Temp Trend	xxx.x	^F/min	SATTREND	
	Supply Air Temperature	xxx.x	°F	SAT	
	Requested Heating Stages	0 to 2		REQHSTGS	
	Heat Stage 1 Timeguard	xxx	sec	TIMGD_H1	
	Heat Stage 2 Timeguard	xxx	sec	TIMGD_H2	
	Heat Stage 1 Available	Yes/No		HT1_AVAL	
	Heat Stage 2 Available	Yes/No		HT2_AVAL	
	Heat Stage 1 Relay	On/Off		HEAT_1	
	Heat Stage 2 Relay	On/Off		HEAT_2	
	Actual Heat Stage Active	x		ACTHSTGS	
	Outdoor Air Temperature	xxx.x	°F	OAT	Forcible
	Return Air Temperature	xxx.x	°F	RAT	Forcible
	Fan Supply Air Temp	xxx.x	°F	FST	
	Econo Commanded Position	0 to 100	%	DAMPCMD	Forcible
	PE_DIAG	0 =None			
1 =MBB RLY11					
2 =MBB RLY06					
PE1 Relay Channel		0 to 2		PE1_CHAN	
PE2 Relay Channel		0 to 2		PE2_CHAN	
PE Turn Off Deadband		0 to 100	%	PE_OFFDB	
Power Exhaust 1 Relay		On/Off		PE1	Forcible
Power Exhaust 2 Relay		On/Off		PE2	Forcible
Econo Commanded Position		0 to 100	%	DAMPCMD	Forcible
Commanded IDF Speed		0 to 100	%	FANSPEED	
P.Exhaust 1 Curve Offset		0 to 100	%	PE1_OFFS	
P.Exhaust 2 Curve Offset		0 to 100	%	PE2_OFFS	
IDF Maximum Fan Speed		80 to 100	%	SPEEDMAX	
Power Exhaust 1 - Speed1		0 to 100	%	PE1_SPD1	
Power Exhaust 1 - Speed2		0 to 100	%	PE1_SPD2	
Power Exhaust 1 - Speed3		0 to 100	%	PE1_SPD3	
PE Stage 1 at Max speed		0 to 100	%	PE1_PMAX	
Power Exhaust 1 - Pos 1		0 to 100	%	PE1_POS1	
Power Exhaust 1 - Pos 2		0 to 100	%	PE1_POS2	
Power Exhaust 1 - Pos 3		0 to 100	%	PE1_POS3	
IDF Maximum Fan Speed		80 to 100	%	SPEEDMAX	
Power Exhaust 2 - Speed1		0 to 100	%	PE2_SPD1	
Power Exhaust 2 - Speed2		0 to 100	%	PE2_SPD2	
Power Exhaust 2 - Speed3	0 to 100	%	PE2_SPD3		
PE Stage 2 at max speed	0 to 100	%	PE2_PMAX		
Power Exhaust 2 - Pos 1	0 to 100	%	PE2_POS1		
Power Exhaust 2 - Pos 2	0 to 100	%	PE2_POS2		
Power Exhaust 2 - Pos 3	0 to 100	%	PE2_POS3		
VENTDIAG	Operating Sub-Mode	see Appendix B		SUBMTEXT	
	Ventilation Status	see Appendix B		VENTTEXT	
	Ventilation Status	see Appendix B		VENTSTAT	
	Currently Occupied	Yes/No		OCCUPIED	Forcible

APPENDIX D — SYSTEMVU™ CONTROLLER CCN TABLES

Table T — MAINTENANCE TABLES (cont)

TABLE	DISPLAY NAME	RANGE	UNITS	POINT NAME	WRITE STATUS	
VENTDIAG (cont)	Mins until next occupied	xxxxx	min	MINTILOC		
	Fan On When Occupied	Yes/No		FANON_OC		
	Commanded IDF Speed	0 to 100	%	FANSPEED		
	Free Cooling Active	Yes/No		FREECOOL		
	Min Position in Effect	0 to 100	%	MIN_POS	Forcible	
	Requested Damper Pos	0 to 100	%	REQDAMP		
	Econo Commanded Position	0 to 100	%	DAMPCMD	Forcible	
	Econo Actual Position	0 to 100	%	DAMPPOS	Forcible	
	Analog Input IAQ Control	0=NO IAQ, 1=DCV, 2=IAQ OVRD, 3=CTRL MINP			IAQANCFG	
	Indoor Air Quality Level	xxxx	PPM	IAQ	Forcible	
	OA Quality Level	xxxx	PPM	OAQ	Forcible	
	Differential Air Quality	xxxx	PPM	AQ_DIFF		
	AQ Differential High	xxxx	PPM	DAQ_HIGH		
	AQ Differential Low	xxxx	PPM	DAQ_LOW		
	AQ Diff High IAQOVERRIDE	0 to 5000	PPM	AQD_HIGH		
	AQ Diff Low- IAQ OVERRIDE	0 to 5000	PPM	AQD_LOW		
	IAQ Override Enable	Yes/No		IAQOVREN		
	IAQ Preoccupancy Purge	Yes/No		IAQPURGE		
	Preocc Purge Lockout OAT	0 to 70	°F	IAQP_LA		
	Ok to Preoccupancy Purge	Yes/No		OKPREOCC		
	Preocc Purge Duration	5 to 120	min	IAQPTIME		
	In Pre-Occupancy Purge?	Yes/No		PREOCCON		
	Is IAQ Override Active?	Yes/No		IAQ_OVRD		
	IAQ override sw state	Yes/No		IAQ_OVRS		
	Economizer Installed?	Yes/No		ECONO		
	Commanded IDF Speed	0 to 100	%	FANSPEED		
	Supply Air Temperature	xxx.x	°F	SAT		
	Return Air Temperature	xxx.x	°F	RAT	Forcible	
	Outdoor Air Temperature	xxx.x	°F	OAT	Forcible	
	Damper SAT Deadband	0 to 20	°F	T24SATDB		
	T24 Min Diff in RAT-OAT	5 to 20	°F	T24RATDF		
	T24 Heat/Cool End Delay	0 to 60	min	T24CHDLY		
	SAT Heat Mode Sensing	Enable/Disable		SAT_HEAT		
	Actual Heat Stage Active	x		ACTHSTGS		
	Actual Cool Stage Active	x		ACTCSTGS		
	OK to Use Free Cooling?	Yes/No		OKFREECL		
	T24 Test Minimum Pos	0 to 100	%	T24STMN		
	Econo Commanded Position	0 to 100	%	DAMPCMD	Forcible	
	T24 Test Maximum Pos	0 to 100	%	T24STMX		
	T24 Econ Min Move for SAT	10 to 20	%	T24ECSTS		
	Econo Actual Position	0 to 100	%	DAMPPOS	Forcible	
	IAQODIAG	AQ Diff High IAQOVERRIDE	0 to 5000	PPM	AQD_HIGH	
		AQ Diff Low-IAQ OVERRIDE	0 to 5000	PPM	AQD_LOW	
		IAQ override enable	Yes/No		IAQOVREN	
		Is IAQ Override Active?	Yes/No		IAQ_OVRD	
IAQ override sw state		Yes/No		IAQ_OVRS		
VENTCURV	Econ Min at Max Fanspeed	0 to 100	%	MINP_MAX		
	Min Pos - User Pos 1	0 to 100	%	MP_UPOS1		
	Min Pos - User Pos 2	0 to 100	%	MP_UPOS2		
	Min Pos - User Pos 3	0 to 100	%	MP_UPOS3		
	IDF Maximum Fan Speed	80 to 100	%	SPEEDMAX		
	Min Pos - User Speed 1	0 to 100	%	MP_USPD1		
	Min Pos - User Speed 2	0 to 100	%	MP_USPD2		

APPENDIX D — SYSTEMVU™ CONTROLLER CCN TABLES

Table T — MAINTENANCE TABLES (cont)

TABLE	DISPLAY NAME	RANGE	UNITS	POINT NAME	WRITE STATUS
VENTCURV (cont)	Min Pos - User Speed 3	0 to 100	%	MP_USPD3	
	User Min Pos Pnt 1 Valid	Yes/No		MP_UPT1	
	User Min Pos Pnt 2 Valid	Yes/No		MP_UPT2	
	User Min Pos Pnt 3 Valid	Yes/No		MP_UPT3	
	Min Pos - Default Pos 1	0 to 100	%	MP_DPOS1	
	Min Pos - Default Pos 2	0 to 100	%	MP_DPOS2	
	Min Pos - Default Pos 3	0 to 100	%	MP_DPOS3	
	Min Pos - Default Speed 1	0 to 100	%	MP_DSPD1	
	Min Pos - Default Speed 2	0 to 100	%	MP_DSPD2	
	Min Pos - Default Speed 3	0 to 100	%	MP_DSPD3	
	Econ Min at Max Fanspeed	0 to 100	%	MINP_MAX	
	Min Pos Curve - Pos 1	0 to 100	%	MP_POS1	
	Min Pos Curve - Pos 2	0 to 100	%	MP_POS2	
	Min Pos Curve - Pos 3	0 to 100	%	MP_POS3	
	IDF Maximum Fan Speed	80 to 100	%	SPEEDMAX	
	Min Pos Curve - Speed 1	0 to 100	%	MP_SPD1	
	Min Pos Curve - Speed 2	0 to 100	%	MP_SPD2	
	Min Pos Curve - Speed 3	0 to 100	%	MP_SPD3	
	IAQ DCV Curve Offset	0 to 100	%	IAQ_OFFS	
	IAQ Position at Max Fan	0 to 100	%	IAQMINP	
	IAQ DCV Curve - Pos 1	0 to 100	%	AQ_POS1	
	IAQ DCV Curve - Pos 2	0 to 100	%	AQ_POS2	
	IAQ DCV Curve - Pos 3	0 to 100	%	AQ_POS3	
	IDF Maximum Fan Speed	80 to 100	%	SPEEDMAX	
	IAQ DCV Curve - Speed 1	0 to 100	%	AQ_SPD1	
	IAQ DCV Curve - Speed 2	0 to 100	%	AQ_SPD2	
	IAQ DCV Curve - Speed 3	0 to 100	%	AQ_SPD3	
	IAQ Purge Curve Offset	0 to 100	%	AQP_OFFS	
	IAQ Purge Pos at Max IDF	0 to 100	%	IAQPMAX	
	IAQ Purge Curve - Pos 1	0 to 100	%	AQP_POS1	
	IAQ Purge Curve - Pos 2	0 to 100	%	AQP_POS2	
	IAQ Purge Curve - Pos 3	0 to 100	%	AQP_POS3	
	IDF Maximum Fan Speed	80 to 100	%	SPEEDMAX	
	IAQ Purge Curve - Speed 1	0 to 100	%	AQP_SPD1	
	IAQ Purge Curve - Speed 2	0 to 100	%	AQP_SPD2	
IAQ Purge Curve - Speed 3	0 to 100	%	AQP_SPD3		
LINKDATA	Linkage CCN Element #	xxx		LNK_SUPE	Forcible
	Linkage CCN Bus Number	xxx		LNK_SUPB	Forcible
	Block No: in Master Zone	1 to 8		LNK_SUPB	Forcible
	Average Occup. Heat Stp.	xxx.x	°F	LNK_SUPB	Forcible
	Average Occup. Cool Stp.	xxx.x	°F	LNK_OCSP	Forcible
	Average Unocc. Heat Stp.	xxx.x	°F	LNK_UHSP	Forcible
	Average Unocc. Cool Stp.	xxx.x	°F	LNK_UHSP	Forcible
	Average Zone Temperature	xxx.x	°F	LNK_AZT	Forcible
	Average Occup. Zone Temp	xxx.x	°F	LNK_AOZT	Forcible
	Linkage Occupied Request	0=Unocc, 1=Occupied, 2=Disabled		LNK_OCC	Forcible
	Linkage Next Occ Day	text string		LNEXTOCD	
	Linkage Next Occ Time	hh:mm		LNEXTOCT	
	Linkage Last Unocc Day	text string		LNEXTUOD	
	Linkage Next Unocc Time	hh:mm		LNEXTUCT	
	Linkage Last Unocc Day	text string		LLASTUOD	
	Linkage Last Unocc Time	hh:mm		LLASTUCT	
	Linkage Active	Yes/No		LNK_ACT	Forcible
Linkage Equipment Mode	Yes/No		LNK_MODE	Forcible	

APPENDIX D — SYSTEMVU™ CONTROLLER CCN TABLES

Table T — MAINTENANCE TABLES (cont)

TABLE	DISPLAY NAME	RANGE	UNITS	POINT NAME	WRITE STATUS	
LINKDATA (cont)	Linkage Start Bias Time	xxx	min	LNK_SBT	Forcible	
	Value of Prime Variable	xxx.x	°F	PRIME_V		
OCC_DIAG	Currently Occupied	Yes/No		OCCUPIED	Forcible	
	Active Occupancy Control	0 = 24/7 OCC, 1 = Schedule, 2 = BASCTRL, 3 = REMOC CTL, 4 = Time Override, 5 = Linkage, 6 = Forced		OCC_CTRL		
	Linkage Occupied Request	0=Unocc, 1=Occupied, 2=Disabled		LNK_OCC	Forcible	
	Timed Override Remaining	0 to 240	min	OVR_EXT	Forcible	
	Remote Occupancy Switch	On/Off		REMOCC	Forcible	
	BMS Occupancy Request	0=Unocc, 1=Occupied, 2=Disabled		BMS_OCC	Forcible	
	Local Sched Occ Request	0=Unocc, 1=Occupied		LOC_OCC	Forcible	
	Active Schedule Period	0 to 8		PER_NO		
	Mins until next occupied	-1 to 10080	min	MINTILOC		
	BACnet Cal Object Status	Yes/No		CALOBJST		
	Today Is A Holiday	Yes/No		HOLTODAY		
	Tomorrow Is A Holiday	Yes/No		HOL_TMRW		
	Next Occupied Day	DDD		NXTOCDAY		
	Next Occupied Time	hh:mm		NXTOCTIM		
	Next Unoccupied Day	DDD		NXTUNDAY		
	Next Unoccupied Time	hh:mm		NXTUNTIM		
	Previous Unoccupied Day	DDD		PRVUNDAY		
	Previous Unoccupied Time	hh:mm	hh.mm	PRVUNTIM		
	Accept Global Holidays?	Yes/No		HOLIDAYT		
	Global Schedule Broadcast	Yes/No		CCN_GSBC		
	CCN Schedule Number	0 to 99		SCHEDNUM		
	0 = Always Occupied					
	1-64 = Local Schedule					
	65-99 = Global Schedule					
	Remote Occupancy Channel	0=None, 1=MBB DI12, 2=MBB DI13, 3=MBB DI14, 4=MBB DI02, 5=MBB DI04		RMOCCCHAN		
	Remote Occupancy Switch	On/Off		REMOCC	Forcible	
	Timed Override Duration	0 to 4	hours	OTL_CFG		
	BAS Protocol Select	0=NONE, 1=CCN, 2=BACNET		BMS_CFG		
	HW_IO	Assigned AI06 Function	0 =None, 1 = IAQ, 2 =OARH, 3 = RARH, 4 =OAQ, 5 = SPRH, 6 =OACFM		MBBAI06F	
		Assigned AI07 Function	0 =None, 1 = IAQ, 2 =OARH, 3 = RARH, 4 =OAQ, 5 = SPRH, 6 =OACFM		MBBAI07F	
		Assigned AI08 Function	0 =None, 1 = IAQ, 2 =OARH, 3 = RARH, 4 =OAQ, 5 = SPRH, 6 =OACFM		MBBAI08F	

APPENDIX D — SYSTEMVU™ CONTROLLER CCN TABLES

Table T — MAINTENANCE TABLES (cont)

TABLE	DISPLAY NAME	RANGE	UNITS	POINT NAME	WRITE STATUS	
HW_IO (cont)	Assigned S-AI01 Function	0 =None, 1 = IAQ, 2 =OARH, 3 = RARH, 4 =OAQ, 5 = SPRH, 6 =OACFM		SIOAI01F		
	Assigned DI02 Function	0 =None, 1 =COFS, 2 = REMOCC, 3 = REMOFF, 4 = Filter, 5 = Enthalpy 6 = General Status, 7 =Humidistat		MBBDI02F		
	Assigned DI04 Function	0 =None, 1 =COFS, 2 = REMOCC, 3 = REMOFF, 4 = Filter, 5 = Enthalpy 6 = General Status, 7 =Humidistat		MBBDI04F		
	Assigned DI12 Function	0 =None, 1 =COFS, 2 = REMOCC, 3 = REMOFF, 4 = Filter, 5 = Enthalpy 6 = General Status, 7 =Humidistat		MBBDI12F		
	Assigned DI12 Function	0 =None, 1 =COFS, 2 = REMOCC, 3 = REMOFF, 4 = Filter, 5 = Enthalpy 6 = General Status, 7 =Humidistat		MBBDI12F		
	Assigned DI13 Function	0 =None, 1 =COFS, 2 = REMOCC, 3 = REMOFF, 4 = Filter, 5 = Enthalpy 6 = General Status, 7 =Humidistat		MBBDI13F		
	Assigned DI14 Function	0 =None, 1 =COFS, 2 = REMOCC, 3 = REMOFF, 4 = Filter, 5 = Enthalpy 6 = General Status, 7 =Humidistat		MBBDI14F		
	Assigned S-DI01 Function	0 =None, 1 =COFS, 2 = REMOCC, 3 = REMOFF, 4 = Filter, 5 = Enthalpy 6 = General Status, 7 =Humidistat		SIODI01F		
	Assigned Rly 06 Function	0 =None, 1 = Alarm Relay, 2 = PE1 3 = PE2		MBBRY06F		
	Assigned Rly 11 Function	0 =None, 1 = Alarm Relay, 2 = PE1 3 = PE2		MBBRY11F		
		Outdoor Air Temp Sensor	xxx.x	°F	OAT_LOC	
		Return Air Temp Sensor	xxx.x	°F	RAT_LOC	
		Space Temperature Sensor	xxx.x	°F	SPT_LOC	
	SPRH Sensor Value	0 to 100	%	SPRH_LOC		
	Local Space Temp Offset	xxxx	°F delta	SPTO_LOC		

APPENDIX D — SYSTEMVU™ CONTROLLER CCN TABLES

Table T — MAINTENANCE TABLES (cont)

TABLE	DISPLAY NAME	RANGE	UNITS	POINT NAME	WRITE STATUS
HW_IO (cont)	OARH Sensor Value	0 to 100	%	OARH_LOC	
	RARH Sensor Value	0 to 100	%	RARH_LOC	
	IAQ Sensor Value	xxxx	ppm	IAQ_LOC	
	OAQ Sensor Value	xxxx	ppm	OAQ_LOC	
	OACFM Sensor Value	xxx.x	cfm	OACFM_LOC	
	Equipment Model Number	xxxxxxxxxxxxxxxxxxxx		EQ_MOD	
	Equipment Serial Number	xxxxxxxxxx		EQ_SER	
	Application SW Version	CESR131651-xx-xx		FW_CESR	
	VFD1 SW Version	text		VFD1_SW	
	SIOB1 SW Version	SIOB1 SW VERSION-xx-xx		SIOB1_SW	
	Bootloader SW Version	CESR131659-xx-xx		BL_CESR	
	MBB Part Number	CEPL131117-xx-R		BD_CEPL	
	MBB Program Part Number	CEPP130644-xx-xx-xx-R		BD_CEPP	
	Base Board Serial Number	xxxxNxxxxxx		BD_SER	
	Zone Sensor Temp Out	-40 to 245	°F	ZSZT	
	ZS1 Temp	-40 to 245	°F	ZS1ZT	
	ZS2 Temperature	-40 to 245	°F	ZS2ZT	
	ZS3 Temperature	-40 to 245	°F	ZS3ZT	
ZS4 Temperature	-40 to 245	°F	ZS4ZT		
ZS5 Temperature	-40 to 245	°F	ZS5ZT		
Zone Sensor Humidity Out	0 to 100	%	ZSSPRH		
ZS1 Humidity	0 to 100	%	ZS1ZHUM		
ZS2 Humidity	0 to 100	%	ZS2ZHUM		
ZS3 Humidity	0 to 100	%	ZS3ZHUM		
ZS4 Humidity	0 to 100	%	ZS4ZHUM		
ZS5 Humidity	0 to 100	%	ZS5ZHUM		
ZS Override Time Remain	0 to 600	min	ZSOTR		
ZS1 Override Time Remain	0 to 600	min	ZS1OTR		
ZS2 Override Time Remain	0 to 600	min	ZS2OTR		
ZS3 Override Time Remain	0 to 600	min	ZS3OTR		
ZS4 Override Time Remain	0 to 600	min	ZS4OTR		
ZS5 Override Time Remain	0 to 600	min	ZS5OTR		
ZS Setpoint Offset Output	-10 to 10	°F delta	ZSSPTO		
ZS1 Cool Setpoint Offset	-10 to 10	°F delta	ZS1CSOFF		
ZS2 Cool Setpoint Offset	-10 to 10	°F delta	ZS2CSOFF		
ZS3 Cool Setpoint Offset	-10 to 10	°F delta	ZS3CSOFF		
ZS4 Cool Setpoint Offset	-10 to 10	°F delta	ZS4CSOFF		
ZS5 Cool Setpoint Offset	-10 to 10	°F delta	ZS5CSOFF		
ZS1 Heat Setpoint Offset	-10 to 10	°F delta	ZS1HSOFF		
ZS2 Heat Setpoint Offset	-10 to 10	°F delta	ZS2HSOFF		
ZS3 Heat Setpoint Offset	-10 to 10	°F delta	ZS3HSOFF		
ZS4 Heat Setpoint Offset	-10 to 10	°F delta	ZS4HSOFF		
ZS5 Heat Setpoint Offset	-10 to 10	°F delta	ZS5HSOFF		
USER_INS	Supply Voltage Leg 1	0 to 700	volt	L1VOLTS	
	Supply Voltage Leg 2	0 to 700	volt	L2VOLTS	
	Supply Voltage Leg 3	0 to 700	volt	L3VOLTS	
	Comp A1 Amps Leg 1	0 to 100	amps	CA1L1_A	
	Comp A1 Amps Leg 2	0 to 100	amps	CA1L2_A	
	Comp A1 Amps Leg 3	0 to 100	amps	CA1L3_A	
	Comp A2 Amps Leg 1	0 to 100	amps	CA2L1_A	
	Comp A2 Amps Leg 2	0 to 100	amps	CA2L2_A	
	Comp A2 Amps Leg 3	0 to 100	amps	CA2L3_A	
	Elec. Heat Amps Leg 1	0 to 100	amps	EHTL1_A	
	Elec. Heat Amps Leg 2	0 to 100	amps	EHTL2_A	
	Elec. Heat Amps Leg 3	0 to 100	amps	EHTL3_A	
	Gas Supply Type	0 =Natural, 1 = LP		GASTYPE	

APPENDIX D — SYSTEMVU™ CONTROLLER CCN TABLES

Table T — MAINTENANCE TABLES (cont)

TABLE	DISPLAY NAME	RANGE	UNITS	POINT NAME	WRITE STATUS
USER_INS (cont)	Gas Inlet Pressure	0 to 20	in. wg	GASPRESS	
	Stage 1 Gas Pressure	0 to 20	in. wg	HT1PRESS	
	Stage 2 Gas Pressure	0 to 20	in. wg	HT2PRESS	
POWRESET	Power Reset Event 00	mm/dd/yy, hh:mm:ss		POWRES00	
	Power Reset Event 01	mm/dd/yy, hh:mm:ss		POWRES01	
	Power Reset Event 02	mm/dd/yy, hh:mm:ss		POWRES02	
	Power Reset Event 03	mm/dd/yy, hh:mm:ss		POWRES03	
	Power Reset Event 04	mm/dd/yy, hh:mm:ss		POWRES04	
	Power Reset Event 05	mm/dd/yy, hh:mm:ss		POWRES05	
	Power Reset Event 06	mm/dd/yy, hh:mm:ss		POWRES06	
	Power Reset Event 07	mm/dd/yy, hh:mm:ss		POWRES07	
	Power Reset Event 08	mm/dd/yy, hh:mm:ss		POWRES08	
ALRESET1	Alarm Reset Event 00	mm/dd/yy, hh:mm:ss		ALMRES00	
	Alarm Reset Event 01	mm/dd/yy, hh:mm:ss		ALMRES01	
	Alarm Reset Event 02	mm/dd/yy, hh:mm:ss		ALMRES02	
	Alarm Reset Event 03	mm/dd/yy, hh:mm:ss		ALMRES03	
	Alarm Reset Event 04	mm/dd/yy, hh:mm:ss		ALMRES04	
	Alarm Reset Event 05	mm/dd/yy, hh:mm:ss		ALMRES05	
	Alarm Reset Event 06	mm/dd/yy, hh:mm:ss		ALMRES06	
	Alarm Reset Event 07	mm/dd/yy, hh:mm:ss		ALMRES07	
	Alarm Reset Event 08	mm/dd/yy, hh:mm:ss		ALMRES08	
ALRESET2	Alarm Reset Event 09	mm/dd/yy, hh:mm:ss		ALMRES09	
	Alarm Reset Event 10	mm/dd/yy, hh:mm:ss		ALMRES10	
	Alarm Reset Event 11	mm/dd/yy, hh:mm:ss		ALMRES11	
	Alarm Reset Event 12	mm/dd/yy, hh:mm:ss		ALMRES12	
	Alarm Reset Event 13	mm/dd/yy, hh:mm:ss		ALMRES13	
	Alarm Reset Event 14	mm/dd/yy, hh:mm:ss		ALMRES14	
	Alarm Reset Event 15	mm/dd/yy, hh:mm:ss		ALMRES15	
	Alarm Reset Event 16	mm/dd/yy, hh:mm:ss		ALMRES16	
	Alarm Reset Event 17	mm/dd/yy, hh:mm:ss		ALMRES17	
	Alarm Reset Event 18	mm/dd/yy, hh:mm:ss		ALMRES18	
	Alarm Reset Event 19	mm/dd/yy, hh:mm:ss		ALMRES19	

APPENDIX D — SYSTEMVU™ CONTROLLER CCN TABLES

Table U — SERVICE CONFIGURATION TABLES

TABLE NAME	DISPLAY NAME	RANGE	UNITS	POINT NAME	DEFAULT
TOUCH	Equip Sys Touch Active		enum	ETST_ACT	
	Equipment Touch SPT		°F	ETSPT	
	Equipment Touch RH		%	ETSPRH	
	System Touch Temp Value		°F	STST_NET	
	System Touch SPRH Value		%	STRH_NET	
	ET ST Aggregated SPT		°F	ETSTSPT	
	ET ST Aggregated SPRH		%	ETSTSPRH	
UNIT_CFG	Unit Startup Delay	10 to 600	sec	STARTDLY	30
	Auxiliary Vent Type	1		VENTTYPE	
	Unit Control Type	0 = Thermostat, 1 = Space Sensor, 2 = RAT Control		CTRLTYPE	0=TSTAT
	Thermostat Hardware Type	0 = 2 Stage Conventional, 1 = 2 Stage Digital, 2 = 3 Stage Conventional, 3 = 3 Stage Digital		STATTYPE	2=CONV 3C2H
	Tstat Adaptive Staging	Yes/No		ADPTSTAT	Yes
	Change Filter Timer	0 to 9999	hours	FILTLIFE	600
	Test Inactivity Time Out	0 =Disabled, 1 = 30 Minutes, 2 = 1 Hour, 3 = 2 Hours, 4 = 4 Hours, 5 = 8 Hours, 6 = 12 Hours		TEST_ITO	4=4 hours
	CCH Max Temperature	40 to 90	°F	CCHMAXT	65
	Std Barometric Pressure	13 to 35	in. Hg	STD_BARP	29.92
	Linkage Stage Inc. Time	60 to 600	sec	LSTAGINC	180
	Unit's Maximum SAT	130 to 210	°F	UMAX_SAT	200
	Auto Clr SAT Limit Fault	Yes/No		SATLACLR	No
	Adaptive Temp Comp Start	Enable/Disable		TCS_CFG	Enable
	User TCS Start Bias Time	0 to 180	min	TCSUBIAS	0
	SIOB 1 Enabled	Yes/No		SIOB1_EN	
DMD_CFG	Low Cool Demand On	-1 to 2	°F	DMDLCON	0.5
	Medium Cool Demand On	0.5 to 20	°F	DMDMCON	1
	High Cool Demand On	0.5 to 20	°F	DMDHCON	2
	Low Cool Demand Off	-1 to 2	°F	DMDLCOFF	-0.5
	Cool Demand Level Up	-2 to 2	°F/min	CDMD_LUP	-0.2
	Low Heat Demand On	-1 to 2	°F	DMDLHON	0.5
	High Heat Demand On	0.5 to 20	°F	DMDHHON	2
	Low Heat Demand Off	-1 to 2	°F	DMDLHOFF	-0.5
	Heat Demand Level Up	-2 to 2	°F/min	HDMD_LUP	-0.2
	Space Demand Time Guard 1	60 to 600	sec	TDMD_TG1	180
	Space Demand Time Guard 2	0 to 600	sec	TDMD_TG2	300
	Space Demand Time Guard 3	5 to 120	min	TDMD_TG3	10
	COOL DMD Offset Level 1	0 to 99	°F	CLDOLEV1	
	COOL DMD Offset Level 2	0 to 99	°F	CLDOLEV2	
	COOL DMD Offset Level 3	0 to 99	°F	CLDOLEV3	
	Heat DMD Offset Level 1	0 to 99	°F	HTDOLEV1	
	Heat DMD Offset Level 2	0 to 99	°F	HTDOLEV2	
	Heat DMD Offset Level 3	0 to 99	°F	HTDOLEV3	
INPUTCFG	Humidistat Status Channel	0 =None, 1 = MBB DI12, 2 = MBB DI13, 3 = MBB DI14, 4 = MBB DI02, 5 = MBB DI04, 6 = SIOB DI01		HUMDCHAN	

APPENDIX D — SYSTEMVU™ CONTROLLER CCN TABLES

Table U — SERVICE CONFIGURATION TABLES (cont)

TABLE NAME	DISPLAY NAME	RANGE	UNITS	POINT NAME	DEFAULT
INPUTCFG (cont)	Filter Status Sw Channel	0 =None, 1 = MBB DI12, 2 = MBB DI13, 3 = MBB DI14, 4 = MBB DI02, 5 = MBB DI04, 6 = SIOB DI01		FILTCHAN	0=None
	Remote Occupancy Channel	0 =None, 1 = MBB DI12, 2 = MBB DI13, 3 = MBB DI14, 4 = MBB DI02, 5 = MBB DI04, 6 = SIOB DI01		RMOCCHAN	0=None
	Remote Shutdown Channel	0 =None, 1 = MBB DI12, 2 = MBB DI13, 3 = MBB DI14, 4 = MBB DI02, 5 = MBB DI04, 6 = SIOB DI01		ROFFCHAN	0=None
	COFS Assigned Channel	0 =None, 1 = MBB DI12, 2 = MBB DI13, 3 = MBB DI14, 4 = MBB DI02, 5 = MBB DI04, 6 = SIOB DI01		COFSCHAN	0=None
	IAQ Override Sw Channel	0 =None, 1 = MBB DI12, 2 = MBB DI13, 3 = MBB DI14, 4 = MBB DI02, 5 = MBB DI04, 6 = SIOB DI01		IAQOCHAN	0=None
	General Status Channel	0 =None, 1 = MBB DI12, 2 = MBB DI13, 3 = MBB DI14, 4 = MBB DI02, 5 = MBB DI04, 6 = SIOB DI01		GEN_CHAN	0=None
	Enthalpy Sw Channel	0 =None, 1 = MBB DI12, 2 = MBB DI13, 3 = MBB DI14, 4 = MBB DI02, 5 = MBB DI04, 6 = SIOB DI01		ENTHCHAN	0=None
	IAQ Assigned Channel	0 =None, 1 = MBB AI06, 2 = MBB AI07, 3 = MBB AI08, 4 = SIOB AI10		IAQ_CHAN	0: no FIOP 1: FIOP
	OAQ Assigned Channel	0 =None, 1 = MBB AI06, 2 = MBB AI07, 3 = MBB AI08, 4 = SIOB AI10		OAQ_CHAN	0=None
	OARH Assigned Channel	0 =None, 1 = MBB AI06, 2 = MBB AI07, 3 = MBB AI08, 4 = SIOB AI10		OARHCHAN	0: no Enthalpy FIOP 3: Enthalpy FIOP
	RARH Assigned Channel	0 =None, 1 = MBB AI06, 2 = MBB AI07, 3 = MBB AI08, 4 = SIOB AI10		RARHCHAN	0=None
	SPRH Assigned Channel	0 =None, 1 = MBB AI06, 2 = MBB AI07, 3 = MBB AI08, 4 = SIOB AI10		SPRHCHAN	
OACFM Assigned Channel	0 =None, 1 = MBB AI06, 2 = MBB AI07, 3 = MBB AI08, 4 = SIOB AI10		OACFMCHAN		

APPENDIX D — SYSTEMVU™ CONTROLLER CCN TABLES

Table U — SERVICE CONFIGURATION TABLES (cont)

TABLE NAME	DISPLAY NAME	RANGE	UNITS	POINT NAME	DEFAULT
INPUTCFG (cont)	Humidistat Switch Type	0 = Normally Open, 1 = Normally Closed		HUMD_CFG	
	Filter Status Switch Type	0 = Normally Open, 1 = Normally Closed		FILT_CFG	0=NORM OPEN
	Remote Occupancy Sw Type	0 = Normally Open, 1 = Normally Closed		RMOC_CFG	0=NORM OPEN
	Remote Shutdown Sw Type	0 = Normally Open, 1 = Normally Closed		ROFF_CFG	0=NORM OPEN
	COFS Switch Type	0 = Normally Open, 1 = Normally Closed		COFS_CFG	1=NORM CLSD
	General Status Sw Type	0 = Normally Open, 1 = Normally Closed		GENS_CFG	0=NORM OPEN
	Enthalpy Switch Type	0 = Normally Open, 1 = Normally Closed		ENTH_CFG	0=NORM OPEN
	IAQ Override Switch Type	0=NORM OPEN, 1=NORM CLSD		IAQOSCFG	0=NORM OPEN
	General Status shutdown?	Yes/No		GENFATAL	Yes
	Remote Shutdown ALM Type	0=Normal, 1=Emergency		ROFFTYPE	0=Normal
	Fire Shutdown Switch	0 =Normally Open, 1 =Normally Closed, 2 =No Switch		FIRE_CFG	2: no FIOP 0: FIOP
	SPRH Sensor Value at 4mA	0 to 100	%	SPRH_4MA	
	SPRH Sensor Value at 20mA	0 to 100	%	SPRH20MA	
	IAQ Sensor Value at 4mA	0 to 5000	ppm	IAQ_4MA	0
	IAQ Sensor Value at 20mA	0 to 5000	ppm	IAQ_20MA	2000
	OAQ Sensor Value at 4mA	0 to 5000	ppm	OAQ_4MA	0
	OAQ Sensor Value at 20mA	0 to 5000	ppm	OAQ_20MA	2000
OARH Sensor Value at 4mA	0 to 100	%	OARH_4MA	0	
OARH Sensor Val. at 20mA	0 to 100	%	OARH20MA	100	
RARH Sensor Value at 4mA	0 to 100	%	RARH_4MA	0	
RARH Sensor Value at 20mA	0 to 100	%	RARH20MA	100	
OACFM value at 4MA	0 to 100	cfm	OCFM_4MA		
OACFM Value at 20mA	0 to 100	cfm	OCFM20MA		
IDF_CFG	Indoor Fan Type	0=None, 1=VFD, 2=DIRECT DRIVE		IDFTYPE	1=VFD: all except Direct Drive motor Option 2 = DIRECT DRIVE: on 04-06 size with direct drive motors
	Number Of Fan Speeds	2 to 3		NUMFSPDS	2
	Fan On When Occupied	Yes/No		FANON_OC	Yes
	IDF Maximum Fan Speed	80 to 100	%	SPEEDMAX	100
	Ventilation Only IDF Spd	0 to 100	%	FSPDVENT	67 (sizes 07-12) 53 (sizes 14 or 20) 56 (sizes 17) 52 (sizes 24) 60 (sizes 26) 50 (sizes 04-06)
	Heating IDF Speed	20 to 100	%	FSPD_HT	100
	Free Cooling IDF Speed	0 to 100	%	FSPD_FCL	67 (sizes 07-12) 53 (sizes 14 or 20) 56 (sizes 17) 52 (sizes 24) 60 (sizes 26) 70 (size 04) 57 (sizes 05-06)
	Low Cooling IDF Speed	20 to 100	%	FSPD_LCL	67 (sizes 07-12) 53 (sizes 14 or 20) 56 (sizes 17) 52 (sizes 24) 60 (sizes 26) 70 (size 04) 57 (sizes 05-06)

APPENDIX D — SYSTEMVU™ CONTROLLER CCN TABLES

Table U — SERVICE CONFIGURATION TABLES (cont)

TABLE NAME	DISPLAY NAME	RANGE	UNITS	POINT NAME	DEFAULT
IDF_CFG (cont)	Med Cooling IDF Speed	20 to 100	%	FSPD_MCL	67 (sizes 07-12) 79 (sizes 14) 82 (sizes 17) 62 (sizes 20) 65 (sizes 24) 72 (sizes 26) 87 (sizes 04) 71 (sizes 05) 69 (sizes 06)
	High Cooling IDF Speed	20 to 100	%	FSPD_HCL	100
	Shut Down on IDF Failure	Yes/No		FATALFAN	Yes
	VFD Hand Mode Shutdown?	Yes/No		HANDSHUT	Yes
	IDF VFD Motor In Reverse	Yes/No		VFD1MDIR	No (sizes 04-12) Yes (sizes 14-26)
	IDF Danfoss Min Ref	0 to 65	Hz	MINREF	0
	IDF Danfoss Max Ref	0 to 65	Hz	MAXREF	60
	IDF Danfoss Comm. TO	1 to 600	sec	CNT_TOUT	30
	IDF Danfoss Auto Reset	0 to 600	sec	ARSTRT_T	30
	IDF Danfoss RFI Filter	On/Off		RFIFILTR	On
	IDF ABB motor direction	x		VFDABBMD	2
	IDF ABB Switching Freq.	x		VFD1SWFQ	2
	IDF ABB Relay Cfg.	x		ABBRELAY	8
	IDF ABB Ext. Relay Cfg.	x		ABBEXRLY	0
	IDF ABB EXT 1 Commands	x		ABB_EXT1	2
	IDF ABB EXT 1 Ref Select	x		ABB_EXTS	2
	IDF ABB ConstSpeed 7	x	Hz	ABB_CSP7	0
	IDF ABB Run Enable	x		VFDRUNEN	7
	IDF ABB Start Enable 1	x		VFDSTAEN	4
	IDF ABB Fault Reset Sel	x		VFDFLTRE	7
	IDF ABB Start Function	x		VFDSTAFN	0
	IDF ABB Stop Function	x		VFDSTPFN	1
	IDF ABB Stall Function	x		VFDSTLFN	2
	IDF ABB Stall Time	x	sec	VFDSTLTM	10
	IDF VFD Motor Volts	50 to 1000	volts	MOTVOLT	See VFD Motor Default Configuration Tables. Table 35 (sizes 04-06) Table 42 (Vert. sizes 07-26) Table 43 (Horz. Sizes 14-26)
	IDF VFD Motor HP	1 to 26	horsepower	MOTPWRHP	See VFD Motor Default Configuration Tables. Table 35 (sizes 04-06) Table 42 (Vert. sizes 07-26) Table 43 (Horz. Sizes 14-26)
	IDF VFD Motor Freq.	20 to 400	Hz	MOTFREQ	60
	IDF VFD Motor Current	0.1 to 40	Amps	MOTCUR	See VFD Motor Default Configuration Tables. Table 35 (sizes 04-06) Table 42 (Vert. sizes 07-26) Table 43 (Horz. Sizes 14-26)
	IDF VFD Max Current	0 to 655.35	Amps	VFD1MAXA	See VFD Motor Default Configuration Tables. Table 35 (sizes 04-06) Table 42 (Vert. sizes 07-26) Table 43 (Horz. Sizes 14-26)
	IDF VFD Motor Nom. RPM	100 to 60000	rpm	MOTNOMSP	See VFD Motor Default Configuration Tables. Table 35 (sizes 04-06) Table 42 (Vert. sizes 07-26) Table 43 (Horz. Sizes 14-26)
IDF VFD Accel. Time	1 to 1800	sec	RAMPUP_T	10	
IDF VFD Decel. Time	1 to 1800	sec	RAMPDN_T	10	
COOL_CFG	Low Cool Compressor	1 to 2		LC_COMP	1
	1 = Compressor A1				
	2 = Compressor A2				
	Compressor Min On Time	180 to 600	sec	C_MINON	300
	Compressor Min Off Time	120 to 600	sec	C_MINOFF	180
	Runtime to Reset Strikes	120 to 999	sec	MIN_ON_S	300
Cool Stage Increase Time	120 to 999	sec	CSTAGINC	450	

APPENDIX D — SYSTEMVU™ CONTROLLER CCN TABLES

Table U — SERVICE CONFIGURATION TABLES (cont)

TABLE NAME	DISPLAY NAME	RANGE	UNITS	POINT NAME	DEFAULT
COOL_CFG (cont)	Cooling SAT Trend Level	-1 to 1	^F/min	SAT_TLC	-0.2
	Cool Min SAT Upper Level	35.0 to 65.0	°F	SATMIN_H	56 (sizes 04-06) 53 (sizes 07-12) 56 (sizes 14-26)
	Cool Min SAT Lower Level	35.0 to 65.0	°F	SATMIN_L	46 (sizes 04-06) 42 (sizes 07-12) 46 (sizes 14-26)
	Cooling Fan-off Delay	0 to 600	sec	COOL_FOD	75
	Circuit A Lockout Temp	-20 to 75	°F	OATLCMPA	0: no Economizer FIOF 40: Economizer FIOF
	Low Ambient Temperature	0-80	°F	LA_TEMP	66
	Low Cool Lockout Temp	-20 to 60	°F	LCLOCKSP	10 (sizes 04-06) 30 (sizes 07-12) 40 (sizes 14-26)
	Medium Cool Lockout Temp	-20 to 60	°F	MCLOCKSP	20 (sizes 07-12) 30 (sizes 14-26)
	Humidimizer Equipped	Yes/No		HUMZ_EN	No: no Humidi-Mizer FIOF Yes: Humidi-Mizer FIOF
	Humidimizer Lockout Temp	-20 to 75	°F	OATLHUMZ	
	Space RH Deadband	0	%	SPRH_DB	
	Low Refrig Charge Level	0 to 150	psi	LOCHARGE	50
	Low Charge Disable Temp	-40 to 50	°F	LOCH_LOT	10
	CirA High Pressure Limit	400 to 700	psig	HIPLIM_A	600
	Low Discharge Level	5 to 20	°F	SDTLEV	0
	Minimum Pressure Ratio	0 to 5		MINPSI_R	1.35
	Suction OK Temperature	10 to 50	°F	SSTOK	18
	Low Suction Level 1 Temp	10 to 50	°F	SSTLEV1	20
	Low Suction Level 2 Temp	5 to 50	°F	SSTLEV2	15
	Low Suction Level 3 Temp	0 to 50	°F	SSTLEV3	10
	Delay On Low SST Check	0 to 300	sec	SSTCKDLY	0
	Comp Level 2 Diag Delay	1 to 99	sec	CDDTLEV2	15 (sizes 04-12) 40 (sizes 14-26)
	Diag Comp Unexpected Off	Enable/Disable		CD_UEOFF	Enable
	Circuit Stuck On Diag.	Enable/Disable		DCKTOFF	Enable
	Min Discharge Change	0 to 99	psi	MDP_DISA	11 (sizes 04-12) 17 sizes 14-26)
	Min Suction Change	0 to 99	psi	MDP_SUCA	4 (sizes 04-06) 6.5 (size 07) 8 (size 08) 7 (sizes 09-12) 14 (sizes 14-26)
	CirA P.Ratio off change	-1 to 1		OFFPR_A	-0.2 (sizes 04-07, 09-14) -0.3 (sizes 08, 17-26)
	Compressor Framework	0 to 2		SYSVTYPE	0 (sizes 07-26) 1 (sizes 04-06)
	0 = 2 Compressors				
	1 = Compressor + Loader				
	2 = Compressor Only				
	Comp A1 Shutdown First	Yes/No		SDWN_A1	Yes (sizes 07-26) No (sizes 04-06)
Compressor A2 Shutdown	Yes/No		SDWN_A2	No	
Comp Loader Shutdown 1st	Yes/No		SDWN_ALD	No (sizes 07-26) Yes (sizes 04-06)	
ODF_CFG	Number of ODF Outputs	0 to 3		NUM_ODF	1 (sizes 04-06) 2 (sizes 07, 17, or 20) 3 (sizes 08-14, 24-26)
	ODF High Cool Speed	0 to 1200	rpm	ODFHCSPPD	1000 (size 04) 1075 (sizes 05-06) 550 (sizes 07-12) 700 (sizes 14-17, 26)

APPENDIX D — SYSTEMVU™ CONTROLLER CCN TABLES

Table U — SERVICE CONFIGURATION TABLES (cont)

TABLE NAME	DISPLAY NAME	RANGE	UNITS	POINT NAME	DEFAULT
ODF_CFG (cont)	ODF Low Cool Speed	0 to 1200	rpm	ODFLCSPD	1000 (size 04) 1075 (sizes 05-06) 700 (sizes 07, 12, 24) 600 (size 08) 650 (size 09) 800 (sizes 14, 17, 26) 750 (size 20)
	ODF Maximum Speed	0 to 1200	rpm	ODFMAXSP	1000 (size 04) 1075 (sizes 05-06) 950 (sizes 07, 09) 900 (size 08) 1000 (sizes 12-26)
	ODF Med Cool Speed	0 to 1200	rpm	ODFMCSPD	1000 (size 04) 1075 (sizes 05-06) 950 (sizes 07, 09) 900 (size 08) 1000 (sizes 12-26)
	ODF Minimum Speed	0 to 1200	rpm	ODFMINS	160
	Low Ambient Temperature	0 to 80	°F	LA_TEMP	66
	ODF Gain	-100 to 100		ODF_KC	50 (sizes 04-06) 1 (size 07) 2 (sizes 08-12) 1.8 (sizes 14-20) 1.4 (sizes 24-26)
	ODF anti-windup factor	-100 to 100		ODF_NI	0.60
	ODF Integral Time	-100 to 100		ODF_TI	20 (sizes 04-12) 40 (sizes 14-26)
	ODF Map Bias Term 1	-200 to 200		ODFBIAS1	72.5 (sizes 04-06) 66.7 (size 07) -44.55 (sizes 08-12) 10 (sizes 14-20) 72.5 (sizes 24-26)
	ODF Map Bias Term 2	-200 to 200		ODFBIAS2	100.98 (sizes 04-06) 95.2 (size 07) 80.59 (sizes 08-12) 35.3 (sizes 14-20) 100.98 (sizes 24-26)
	ODF Map Bias Term 3	-200 to 200		ODFBIAS3	20.93 (sizes 04-06) 0 (sizes 07, 14-20) 65.29 (sizes 08-12) 114.74 (sizes 24-26)
	ODF Fan Switch Point 1	-100 to 100		ODFPIUP1	3.68 (size 07) 3.4 (sizes 08-12) 4.84 (sizes 14-20) 1.58 (sizes 24-26)
	ODF Fan Switch Point 2	-100 to 100		ODFPIUP2	17.1 (size 07) 9.06 (sizes 08-12) 22.3 (sizes 14-20)
	ODF Fans Switch Point 3	-100 to 100		ODFPIUP3	100 (sizes 07, 14-20) 19.76 (sizes 08-12) 20.93 (sizes 24-26)
	ODF Proportional ctrl Pr	-100 to 100		ODFPR_KC	1.4 (sizes 04-06) 25 (sizes 07-12) 50 (sizes 14-26)
	ODF Map Slope Term 1	-100 to 100		ODFSLPE1	55.33 (sizes 04-06) 25.3 (size 07) 60.09 (sizes 08-12) 31 (sizes 14-20) 55.33 (sizes 24-26)
	ODF Map Slope Term 2	-100 to 100		ODFSLPE2	19.07 (sizes 04-06) 9 (size 07) 18.69 (sizes 08-12) 9.6 (sizes 14-20) 19.07 (sizes 24-26)
	ODF Map Slope Term 3	-100 to 100		ODFSLPE3	8.85 (sizes 04-06) 1 (sizes 07, 14-20) 9.34 (sizes 08-12) 8.85 (sizes 24-26)
	Low Ambient Dehum Lev 1	0 to 80	°F	LAHTEMP1	
	Low Ambient Dehum Lev 2	0 to 61	°F	LAHTEMP2	
	Low Ambient Dehum Lev 3	0 to 55	°F	LAHTEMP3	
	LA Dehum SDT SP Lev 1	0 to 93	°F	LHSDTSP1	
	LA Dehum SDT SP Lev 2	0 to 93	°F	LHSDTSP2	
LA Dehum SDT SP Lev 3	0 to 104	°F	LHSDTSP3		

APPENDIX D — SYSTEMVU™ CONTROLLER CCN TABLES

Table U — SERVICE CONFIGURATION TABLES (cont)

TABLE NAME	DISPLAY NAME	RANGE	UNITS	POINT NAME	DEFAULT
HEATCFG	Type of Heat Installed	0=Electric 1=Gas		HEATTYPE	0 (50 series) 1 (48 series)
	Number of Heating Stages	0 to 2		NUMHSTGS	1 (50 Series, sizes 04-06 low or medium heat) 2 (all except below): 0 (50 series without FIOP heat), 1 (50 series, sizes 07-14 and low heat), 1 (50 series, sizes 07-12 and medium heat)
	Heat Minimum On Time	60 to 600	sec	H_MINON	120
	Heat Minimum Off Time	60 to 600	sec	H_MINOFF	120
	Heat Stage Increase Time	120 to 999	sec	HSTAGINC	450
	Heating SAT Trend Level	-1 to 1	^F/min	^F/min	0.2
	Heat Max SAT Lower Level	85 to 200	°F	SATMAX_L	140
	Heat Max SAT Upper Level	85 to 200	°F	SATMAX_H	160
	Heating Fan-off Delay	10 to 600	sec	HEAT_FOD	30 (50 series) 45 (48 series)
	Heating Lockout Temp	40 to 125	°F	OATLHEAT	75
	SAT Heat Mode Sensing	Enable/Disable		SAT_HEAT	Disable
	No IGC IFO Input Timeout	0 to 60	min	NO_IGCTM	5
	Pre-Heat HX without IDF?	Enable/Disable		PREHT_HX	Disable
	Pre-Heat Fan On Delay	0 to 120	sec	PREHT_TM	30
	Supply Air Tempering Enable	Yes/No		SATEMPEN	
	SA Tempering Setpoint	xx	°F	SATEMPSP	
	Max OAT for SA Tempering	0	°F	OATSTEMP	
	ECON_CFG	Economizer Installed?	Yes/No		ECONO
Econ Max Damper Position		0 to 100	%	DAMPMAX	100
Economizer Travel Time		5 to 300	sec	ECONOTRV	150
IDF Maximum Fan Speed		80 to 100	%	SPEEDMAX	
Econ Min at Max Fan Speed		0 to 100	%	MINP_MAX	30
Min Pos - User Speed 1		0 to 100	%	MP_USPD1	0
Min Pos - User Pos 1		0 to 100	%	MP_UPOS1	0
Min Pos - User Speed 2		0 to 100	%	MP_USPD2	0
Min Pos - User Pos 2		0 to 100	%	MP_UPOS2	0
Min Pos - User Speed 3		0 to 100	%	MP_USPD3	0
Min Pos - User Pos 3		0 to 100	%	MP_UPOS3	0
Low Free Cool SAT Setpnt		40 to 80	°F	LCSASP	65
High Free Cool SAT Setpnt		40 to 80	°F	HCSASP	55
Free Cooling Max OAT		0 to 90	°F	MAXFREET	65
Free Cooling Min Temp		-30 to 70	°F	MINFREET	0
Diff. Dry Bulb Control		Enable/Disable		DIFFBULB	Disable
Diff. Dry Bulb Deadband		0 to 20	°F	OATRATDB	3
Max Enthalpy OA Limit		1 to 99	Btu/lb	FREEMAXE	28
Diff. Enthalpy Control		Enable/Disable		DIFFENTH	Disable
Enthalpy Cross Deadband		0 to 20	Btu/lb	OAERAEDB	2
ECONO PID - KP	0.00 to 99.90		ECONO_P	2.5	
ECONO PID - KI	0.00 to 99.90		ECONO_I	0.12	
ECONO PID - KD	0.00 to 99.90		ECONO_D	1	
ECONO PID - RATE	10 to 180	sec	ECONO_DT	15	
When to Unocc Free Cool?	0 to 2		UFC_CFG	1=PreOcc	
0 =Disabled					
1 = Pre-Occupancy					
2 = Unoccupied					
UFC PreOcc Time	1 to 999	min	UFCTIME	120	
Unocc Free Cool Low Temp	-30 to 70	°F	OATLUFC	50	
IDF Maximum Fan Speed	80 to 100	%	SPEEDMAX		
PE Stage 1 at Max Speed	0 to 100	%	PE1_PMAX	40	

APPENDIX D — SYSTEMVU™ CONTROLLER CCN TABLES

Table U — SERVICE CONFIGURATION TABLES (cont)

TABLE NAME	DISPLAY NAME	RANGE	UNITS	POINT NAME	DEFAULT
ECON_CFG (cont)	PE1 Relay Channel	0=NONE, 1=MBB RLY11, 2=MBB RLY06		PE1_CHAN	0: no FIOP 2: FIOP
	PE Turn Off Deadband	0 to 100	%	PE_OFFDB	5
	PE2 Relay Channel	0=NONE, 1=MBB RLY11, 2=MBB RLY06		PE2_CHAN	0=None
	PE Stage 2 at Max Speed	0 to 100	%	PE2_PMAX	75
	T24 Heat/Cool End Delay	0 to 60	min	T24CHDLY	25
	T24Econ Min Move for SAT	10 to 20	%	T24ECSTS	10
	Damper SAT Deadband	0 to 20	°F	T24SATDB	12
	T24 Min Diff in RAT-OAT	5 to 20	°F	T24RATDF	15
	T24 Test Minimum Pos	0 to 100	%	T24TSTMN	15
	T24 Test Maximum Pos	0 to 100	%	T24TSTMX	85
IAQ_CFG	Analog Input IAQ Control	0 to 3		IAQANCFG	0: no FIOP 1: FIOP
	0 =No IAQ				
	1 =DCV				
	2 = IAQ Override				
	3 =MINPOS Control				
	IAQ Position at Max Fan	0 to 100	%	IAQMINP	10
	AQ Differential Low	0 to 5000	ppm	DAQ_LOW	100
	AQ Differential High	0 to 5000	ppm	DAQ_HIGH	700
	IAQ Preoccupancy Purge	Yes/No		IAQPURGE	Yes
	IAQ Purge Pos at Max IDF	0 to 100	%	IAQPMAX	40
	Preocc Purge Lockout OAT	0 to 70	°F	IAQP_LA	50
	Preocc Purge Duration	5 to 120	min	IAQPTIME	15
	IAQ Sensor Value at 4mA	0 to 5000	ppm	IAQ_4MA	0
	IAQ Sensor Value at 20mA	0 to 5000	ppm	IAQ_20MA	2000
	OAQ Sensor Value at 4mA	0 to 5000	ppm	OAQ_4MA	0
	OAQ Sensor Value at 20mA	0 to 5000	ppm	OAQ_20MA	2000
	IAQ Override Sw Channel	0 to 6		IAQOCHAN	
IAQ Override Switch Type	Yes/No		IAQOSCFG		
ALM_CFG	ALM Relay Assigned Chan	0 to 2		ALM_CHAN	1=MBB RLY11
	0 =None				
	1 =MBB RLY11				
	2 =MBB RLY06				
	Thermostat Alerts	Yes/No		TSTAT_AL	Yes
	Hardware Failures Alerts	Yes/No		HW_AL	Yes
	SAT/RAT Sensor Alerts	Yes/No		SATRATAL	Yes
	OAT Thermistor Alerts	Yes/No		OATRL_AL	Yes
	Space Sensors Alerts	Yes/No		SPACE_AL	Yes
	Transducer Sensor Alerts	Yes/No		TRANS_AL	Yes
	RH Sensor Failure Alert	Yes/No		RHS_AL	Yes
	Air Quality CO ₂ Alerts	Yes/No		CO2S_AL	Yes
	OACFM Alarm Relay	Yes/No		OACFM_AL	
	Economizer Alerts	Yes/No		ECON_AL	Yes
	Dirty Filter Alerts	Yes/No		FILT_AL	Yes
	General Status Alerts	Yes/No		GENS_AL	Yes
	Refrig Circuit Alerts	Yes/No		CKT_AL	Yes
	Compressor Alerts	Yes/No		COMP_AL	Yes
	Heating Failure Alerts	Yes/No		HEAT_AL	Yes
	Indoor Fan Alerts	Yes/No		FAN_AL	Yes
	Relay on Active IOBA	Yes/No		IOBFA_AL	
Relay on Active Faults	Yes/No		FAULT_AL	Yes	
ZSENSCFG	Zone Sensor 1 Address	0 to 255		ZSADDR1	255
	Zone Sensor 2 Address	0 to 255		ZSADDR2	255
	Zone Sensor 3 Address	0 to 255		ZSADDR3	255
	Zone Sensor 4 Address	0 to 255		ZSADDR4	255
	Zone Sensor 5 Address	0 to 255		ZSADDR5	255

APPENDIX D — SYSTEMVU™ CONTROLLER CCN TABLES

Table U — SERVICE CONFIGURATION TABLES (cont)

TABLE NAME	DISPLAY NAME	RANGE	UNITS	POINT NAME	DEFAULT
ZSENSCFG (cont)	ZS Force Unoccup Enable	No		ZSFUNEN	No
	ZS Force Unocc Wt Delay	No		ZSFUNWT	No
	Zone Sensor Poll Rate	1 to 100	sec	ZSPOLLRT	5
	ZS TLO Cont Enable	No		ZSTLOEN	No
	ZS TLO Set During Occ	No		ZSTLSOC	No
	Zone Sensor UI Mode	1=Dual Offsets		ZSUIM	1=Dual Offsets
	Zone Sensor Unit	0=degrees F		ZSUNIT	0=degrees F
TOUCHCFG	System Touch Device Inst	0 to 4194303		DEVST	
	System Touch Poll Rate	10 to 60	sec	POLLST	
	System Touch AI for SPT	0 to 9999		AISTSPT	
	System Touch AI for SPRH	0 to 9999		AISTSPRH	
TRIM	OAT Sensor Trim Offset	-10 to 10	°F	OAT_TRIM	0
	RAT Sensor Trim Offset	-30 to 30	°F	RAT_TRIM	0
	FST Sensor Trim Offset	-10 to 10	°F	FST_TRIM	0
	SPT Sensor Trim Offset	-30 to 30	°F	SPT_TRIM	0
	SPTO Sensor Offset Trim	-1 to 1	°F	SPTOTRIM	0
	SPRH Sensor Trim Offset	-15 to 15	%	SPRHTRIM	
	IAQ Sensor Trim Offset	-200 to 200	ppm	IAQ_TRIM	0
	OAQ Sensor Trim Offset	-200 to 200	ppm	OAQ_TRIM	0
	OARH Sensor Trim Offset	-15 to 15	%	OARHTRIM	0
	RARH Sensor Trim Offset	-15 to 15	%	RARHTRIM	0
	Cir.A SSP Sensor Trim	-50 to 50	psig	SSPATRIM	0
	Cir.A SDP Sensor Trim	-50 to 50	psig	SDPATRIM	0
	Econ Fdback Trim Offset	-15 to 15	%	EC1DTRIM	0
	OACFM Sensor Trim Offset	-10 to 10	cfm	OCFMTRIM	0
DISPLAY	Metric Display	Yes/No		DISPUNIT	No
	Display Language Select	0=English, 1=Spanish, 2=French, 3=Portuguese		LANGUAGE	0=English
	LCD Contrast Adjustment	1 to 10		LCD_CONT	5
	User Password Protection	Enable/Disable		PASS_EBL	Enable
	User Password	0 to 9999		PASSWORD	1111

APPENDIX D — SYSTEMVU™ CONTROLLER CCN TABLES

Table V — CONFIGURATION TABLES

TABLE NAME	DISPLAY NAME	RANGE	UNITS	POINT NAME	DEFAULT
SCHEDOVR	CCN Schedule Number	0 = Always Occupied, 1-64 = Local Schedule, 65-99 = Global Schedule		SCHEDNUM	0 = Always Occupied
	Accept Global Holidays?	Yes/No		HOLIDAYT	No
	Global Schedule Broadcast	Yes/No		CCN_GSBC	No
	Timed Override Duration	0 to 4	hours	OTL_CFG	4
	Timed Override Remaining	0 to 240	min	OVR_EXT	Forcible
	Remote Occupancy Channel	0=None, 1=MBB DI12, 2=MBB DI13, 3=MBB DI14, 4=MBB DI02, 5=MBB DI04, 6=SI0B DI01		RMOCCCHAN	0=None
	Allow Global Overrides	Yes/No		GLBLOVER	Yes
	Allow SPT Ovrld Cancel	Yes/No		CLROVCFG	No
	BAS_CFG	BAS Protocol Select	0=NONE, 1=CCN, 2=BACNET		BMS_CFG
Network Input Timeout		0 to 600	min	NETINTO	30
CCN Bus Number		0 to 239		CCNBUS	0
CCN Element Number		1 to 239		CCNADD	1
CCN Baud Rate		0=9600, 1=19200, 2=38400		BAUDENUM	2
BACnet ID Number		0 to 4194302		BAC_ID	1610101
BACnet Device Macaddress		1 to 127		BAC_MAC	1
BACnet BMS baud rate		0=9600, 1=19200, 2=38400, 3=57600, 4=76800, 5=115200		BAC_BAUD	4=76800
BACnet ID Auto ID		Yes/No		BAC_AUID	Yes
ALC Auto ID Scheme		Yes/No		AUID	Yes
BACNET		BACnet ID Number	0 to 4194302		BAC_ID
	BACnet Device Macaddress	1 to 127		BAC_MAC	1
	BACnet BMS baud rate	0=9600, 1=19200, 2=38400, 3=57600, 4=76800, 5=115200		BAC_BAUD	4=76800
	BACnet ID Auto ID	Yes/No		BAC_AUID	Yes
	ALC Auto ID Scheme	Yes/No		BAC_AUID	Yes
	BACnet device for IAQ	0 to 4194303		DEVIAQ	1610100
	Object instance for IAQ	0 to 9999		OBJIAQ	1009
	Change of value for IAQ	0 to 60		COVIAQ	0
	BACnet device for OAQ	0 to 4194303		DEVOAQ	1610100
	Object instance for OAQ	0 to 9999		OBJOAQ	285
	Change of value for OAQ	0 to 60		COVOAQ	0
	BACnet device for OARH	0 to 4194303		DEVOARH	1610100
	Object instance for OARH	0 to 9999		OBJOARH	1022
	Change of value for OARH	0 to 60		COVOARH	0
	BACnet device for OAT	0 to 4194303		DEVOAT	1610100
	Object instance for OAT	0 to 9999		OBJOAT	1003
	Change of value for OAT	0 to 60		COVOAT	0
BACnet device for RARH	0 to 4194303		DEVRARH	1610100	
Object instance for RARH	0 to 9999		OBJRARH	30	
Change of value for RARH	0 to 60		COVRARH	0	
BACnet device for RAT	0 to 4194303		DEVSTAT	1610100	
Object instance for RAT	0 to 9999		OBJRAT	1010	
Change of value for RAT	0 to 60		COVRAT	0	
BACnet device for SPT	0 to 4194303		DEVSTAT	1610100	

APPENDIX D — SYSTEMVU™ CONTROLLER CCN TABLES

Table V — CONFIGURATION TABLES (cont)

TABLE NAME	DISPLAY NAME	RANGE	UNITS	POINT NAME	DEFAULT	
BACNET (cont)	Object instance for SPT	0 to 9999		OBJSP	2007	
	Change of value for SPT	0 to 60		COVSPT	0	
	Allow Local Sched Edit	Yes/No		LCL_EDIT		
	CCN Broadcast Ack'er	Yes/No		CCNBCACK	No	
	Global Schedule Broadcast	Yes/No		CCN_GSBC	No	
	CCN Time Broadcast	Yes/No		CCNBC	No	
	Broadcast OAT On Network	Yes/No		OATBC	No	
	Broadcast OARH On Network	Yes/No		OARHBC	No	
	Broadcast OAQ On Network	Yes/No		OAQBC	No	
	Broadcast IAQ On Network	Yes/No		IAQBC	No	
	DST allowed?	Enable/Disable		DST_CFG	Enable	
	DST Start Month	1=JANUARY, 2=FEBRUARY, 3=MARCH, 4=APRIL, 5=MAY, 6=JUNE, 7=JULY, 8=AUGUST, 9=SEPTEMBER, 10=OCTOBER, 11=NOVEMBER, 12=DECEMBER		STARTM	3=MARCH	
	DST Start Week	1 to 5		STARTW	2	
	DST Start Day	1=MONDAY, 2=TUESDAY, 3=WEDNESDAY, 4=THURSDAY, 5=FRIDAY, 6=SATURDAY, 7=SUNDAY		STARTD	7=SUNDAY	
BRODEFS	DST Minutes to Add	0 to 90	min	MINADD	60	
	DST Stop Month	1=JANUARY, 2=FEBRUARY, 3=MARCH, 4=APRIL, 5=MAY, 6=JUNE, 7=JULY, 8=AUGUST, 9=SEPTEMBER, 10=OCTOBER, 11=NOVEMBER, 12=DECEMBER		STOPM	11=NOVEMBER	
	DST Stop Week	1 to 5		STOPW	1	
	DST Stop Day	1=MONDAY, 2=TUESDAY, 3=WEDNESDAY, 4=THURSDAY, 5=FRIDAY, 6=SATURDAY, 7=SUNDAY		STOPD	7=SUNDAY	
	DST Minutes to Subtract	0 to 90	min	MINSUB	60	
	Time in day to start DST	0 to 600	min	DST_TOD	120	
	ALARMDEF	Alarm Routing Control	00000000 to 11111111		ALRM_CNT	11000000
		Equipment Priority	0 to 7		EQP_TYPE	5
Comm Failure Retry Time		1 to 240	min	RETRY_TM	10	
Re-Alarm Time		1 to 255	min	RE-ALARM	180	
Alarm System Name		up to 8 alphanum		ALRM_NAM	48_50LC_	
HOLIDAY HOLDYxxS MON DAY LEN (repeat up to xx=30 Holidays)	Holiday Start Month	1 to 12 = January to December		HD01STMN - HD30STMN	0	
	Holiday Start Day	1 to 31		HD01STDY - HD30STDY	0	
	Holiday Duration (days)	1 to 99		HD01LEN - HD30LEN	0	

APPENDIX D — SYSTEMVU™ CONTROLLER CCN TABLES

Table V — CONFIGURATION TABLES (cont)

TABLE NAME	DISPLAY NAME	RANGE	UNITS	POINT NAME	DEFAULT
OCCDEFCS OCCPC01S	Timed Override Remaining	0 to 240	min	OVR_EXT	Forcible
	Period x DOW (MTWTFSSH)	00000000 to 11111111		DOWx	00000000
	Occupied from	hh:mm		OCCTODx	00:00
	Occupied to	hh:mm		UNOCTODx	00:00
	(repeat up to x=8 periods)				



APPENDIX D — SYSTEMVU™ CONTROLLER CCN TABLES

Table W — SETPOINT TABLE

TABLE NAME	DISPLAY NAME	RANGE	UNITS	POINT NAME	DEFAULT
SET_PNT	Occupied Cool Setpoint	55 to 80	°F	OCSP	78
	Occupied Heat Setpoint	55 to 80	°F	OHSP	68
	Unoccupied Cool Setpoint	65 to 95	°F	UCSP	85
	Unoccupied Heat Setpoint	40 to 80	°F	UHSP	60
	Heat-Cool Setpoint Gap	2 to 10	^F	HCSP_GAP	5
	SPT Offset Range (±)	0 to 5	°F	SPTO_RNG	5
	Occupied SPRH Setpoint	0 to 100	%	SPRH_OSP	55
	Unoccupied SPRH Setpoint	0 to 100	%	SPRH_USP	55

Table X — CONTROL ID TABLE

TABLE NAME	DISPLAY NAME	RANGE	UNITS	POINT NAME	DEFAULT
CTRLID	Device Name:	48_50LC_			
	Description:	text string			
	Location:	text string			
	Software Part Number:	CESR131651-XX-XX			
	Model Number:	xxxxxxxxxxxxxxxxxxxx			
	Serial Number:	xxxxxxxxxx			
	Reference Number:				

The SystemVu controller is i-Vu® compatible and includes equipment and view files that organize the BACnet points for the graphic page and property pages in i-Vu. The controller supports single point linkage, proprietary i-Vu zoning linkage, and the BACnet notification object for alarms.

When notification of alarms is turned off, this does not mean the Alarm condition has been cleared. It just means the notification of the alarm has been temporarily stopped. If the alarm condition still exists after a delay, the notifications will start being sent again.

Table Y — BACnet* AV Points List

POINT DESCRIPTION	POINT ACCESS	UNITS	BACNET OBJECT NAME	BACNET ID	VALUE RANGE	CCN POINT EQUIVALENT
A1 Loader Resets Count	READ ONLY		rs_aldr	AV:7012	0 to 65535	RS_ALDR
Actual Cool Stage Active	READ ONLY		actcstgs	AV:194	0 to 3	ACTCSTGS
Actual fan status	R/W		idf_status	AV:190	0 to 100	IDF_STAT
Actual Heat Stage Active	READ ONLY		acthstgs	AV:46	0 to 2	ACTHSTGS
Alarm display info	READ ONLY		alarm_info	AV:14	0 to 2	ALARM
Alarm Relay Resets Count	READ ONLY		rs_alm	AV:99	0 to 65535	RS_ALM
Alarm Relay Run Hours	READ ONLY	hrs	hour_alarm	AV:49	0 to 999999	HR_ALM
Alarm Relay Starts	READ ONLY		st_alm	AV:136	0 to 999999	ST_ALM
Alarm Reset Counts	READ ONLY		st_alrst	AV:137	0 to 999999	ST_ALRST
Alarm Reset Resets Count	READ ONLY		rs_alrst	AV:100	0 to 65535	RS_ALRST
AQ Diff Low-IAQ OVERRIDE	R/W	PPM	aqd_low	AV:443	0 to 5000	AQD_LOW
AQ Differential High	R/W		daq_high	AV:212	0 to 5000	DAQ_HIGH
AQ Differential Low	R/W		daq_low	AV:213	0 to 5000	DAQ_LOW
AQ DiffHigh-IAQ OVERRIDE	R/W	PPM	aqd_high	AV:442	0 to 5000	AQD_HIGH
Average Occup. Cool Stp.	R/W	°F	lnk_ocsp	AV:264	55 to 80	LNK_OCSP
Average Occup. Heat Stp.	R/W	°F	lnk_ohsp	AV:266	55 to 80	LNK_OHSP
Average Occup. Zone Temp	R/W	°F	lnk_aozt	AV:255	-40 to 245	LNK_AOZT
Average Unocc. Cool Stp.	R/W	°F	lnk_ucsp	AV:274	65 to 90	LNK_UCSP
Average Unocc. Heat Stp.	R/W	°F	lnk_uhsp	AV:275	40 to 80	LNK_UHSP
Average Zone Temperature	R/W	°F	lnk_azt	AV:256	-40 to 245	LNK_AZT
BACKUP Preparation Time	READ ONLY		bkpreptm	AV:336	0 to 65535	BKPREPTM
BACnet device for IAQ	R/W		deviaq	AV:8001	0 to 4194303	DEVIAQ
BACnet device for OAQ	R/W		devoaq	AV:8002	0 to 4194303	DEVOAQ
BACnet device for OARH	R/W		devoarh	AV:8004	0 to 4194303	DEVOARH
BACnet device for OAT	R/W		devoat	AV:8003	0 to 4194303	DEVOAT
BACnet device for RARH	R/W		devrarh	AV:8005	0 to 4194303	DEVRARH
BACnet device for RAT	R/W		devrat	AV:8006	0 to 4194303	DEVSTAT
BACnet device for SPRH	R/W		devsprh	AV:8028	0 to 4194303	DEVSPRH
BACnet device for SPT	R/W		devspt	AV:8007	0 to 4194303	DEVSPRT
BACnet Device Macaddress	R/W		bac_mac	AV:189	0 to 127	BAC_MAC
BACnet ID Number	R/W		bac_id	AV:188	0 to 4194302	BAC_ID

APPENDIX E — BACNET POINTS LIST

Table Y — BACnet* AV Points List (cont)

POINT DESCRIPTION	POINT ACCESS	UNITS	BACNET OBJECT NAME	BACNET ID	VALUE RANGE	CCN POINT EQUIVALENT
Barometric Pressure	R/W	IN_HG_OF_KPAG	barp	AV:161	10 to 35	BARP
Block No: in Master Zone	R/W		lnk_mzblk	AV:262	0 to 255	LNK_MZBK
CCH Max Temperature	R/W	°F	cch_max_t	AV:2	40 to 90	CCHMAXT
CCH1 Relay Resets Count	READ ONLY		rs_cchr1	AV:294	0 to 65535	RS_CCHR1
CCH1 Relay Run Hours	READ ONLY	hrs	hour_cchr1	AV:242	0 to 999999	HR_CCHR1
CCH1 Relay Starts	READ ONLY		st_cchr1	AV:301	0 to 999999	ST_CCHR1
Change Filter Timer	R/W	hrs	filter_service_hrs	AV:2019	0 to 9999	FILT LIFE
Change of value for IAQ	R/W		coviaq	AV:8015	0 to 60	COVIAQ
Change of value for OAQ	R/W		covoaq	AV:8016	0 to 60	COVOAQ
Change of value for OARH	R/W		covoarh	AV:8018	0 to 60	COVOARH
Change of value for OAT	R/W		covoat	AV:8017	0 to 60	COVOAT
Change of value for RARH	R/W		covrarh	AV:8019	0 to 60	COVRARH
Change of value for RAT	R/W		covrat	AV:8020	0 to 60	COVRAT
Change of value for SPRH	R/W		covsprh	AV:8030	0 to 60	COVSPRH
Change of value for SPT	R/W		covspt	AV:8021	0 to 60	COVSPT
Cir.A Discharge Pressure	R/W	PSI	sdp_a	AV:124	-67.06 to 699.63	SDP_A
Cir.A Sat.Discharge Temp	READ ONLY	°F	sdt_a	AV:295	-100 to 500	SDT_A
Cir.A Sat.Suction Temp	READ ONLY	°F	sst_a	AV:339	-100 to 500	SST_A
Cir.A Suction Pressure	READ ONLY	PSI	ssp_a	AV:131	-47.33 to 430.16	SSP_A
Circuit A Pressure Ratio	READ ONLY		cira_pr	AV:204	14.5 to 667.0	CIRA_PR
CLV_A Resets Count	READ ONLY		rs_clv_a	AV:455	0 to 65535	RS_CLV_A
CLV_A Run Hours	READ ONLY	hrs	hr_clv_a	AV:457	0 to 999999	HR_CLV_A
CLV_A Starts	READ ONLY		st_clv_a	AV:459	0 to 999999	ST_CLV_A
CMP A1 Loader Run Hours	READ ONLY	hrs	hr_aldr	AV:7010	0 to 999999	HR_ALDR
CMP A1 Loader Starts	READ ONLY		st_aldr	AV:7011	0 to 999999	ST_ALDR
cmp Loader Timeguard	READ ONLY	sec	timg_ald	AV:164	0 to 600	TIMG_ALD
Commanded IDF Speed	READ ONLY	%	sf_vfd_feedback	AV:6	-2 to 2	FANFB
Commanded IDF Speed	READ ONLY	%	vfd_output	AV:2027	0.0f to 1.0f	FANSPEED
Commanded ODF Speed	READ ONLY	RPM	odf_out_speed	AV:87	0 to 2000	ODFSPD
Comp A1 Resets Count	READ ONLY		rs_a1	AV:97	0 to 65535	RS_A1
Comp A2 Resets Count	READ ONLY		rs_a2	AV:98	0 to 65535	RS_A2
Compressor A1 Run Hours	READ ONLY	hrs	hour_a1	AV:47	0 to 999999	HR_A1
Compressor A1 Run Hours	READ ONLY	hrs	hr_rlv_a	AV:458	0 to 999999	HR_RLV_A
Compressor A1 Starts	READ ONLY		st_a1	AV:134	0 to 999999	ST_A1
Compressor A1 strikes	READ ONLY		a1strike	AV:192	0 to 3	A1STRIKE
Compressor A1 Timeguard	READ ONLY	sec	timgd_a1	AV:162	0 to 600	TIMGD_A1
Compressor A2 Run Hours	READ ONLY	hrs	hour_a2	AV:48	0 to 999999	HR_A2
Compressor A2 Starts	READ ONLY		st_a2	AV:135	0 to 999999	ST_A2
Compressor A2 Strikes	READ ONLY		a2strike	AV:193	0 to 3	A2STRIKE
Compressor A2 Timeguard	READ ONLY	sec	timgd_a2	AV:157	0 to 600	TIMGD_A2
Compressor Min Off Time	R/W	sec	c_minoff	AV:202	120 to 600	C_MINOFF
Compressor Min On Time	R/W	sec	c_minon	AV:203	180 to 600	C_MINON
COOL DMD Offset level 1	R/W	°F	cdlm_level1	AV:400	0 to 40	CLDLEVEL1
COOL DMD Offset level 2	R/W	°F	cdlm_level2	AV:401	0 to 40	CLDLEVEL2
COOL DMD Offset level 3	R/W	°F	cdlm_level3	AV:402	0 to 40	CLDLEVEL3
Cool Mode Select T.guard	READ ONLY	sec	cl_sel_timeguard	AV:40	0 to 65535	COOLMSTG
Cool Setpoint in Effect	READ ONLY	°F	csp_eff	AV:208	55 to 95	CSP_EFF
Cool Shed 1 demand band	R/W		coolsh1	AV:6014	0 to 55	COOLSH1
Cool Shed 2 demand band	R/W		coolsh2	AV:6015	0 to 55	COOLSH2
Cool Shed 3 demand band	R/W		coolsh3	AV:6016	0 to 55	COOLSH3
Cooling Demand Trend	READ ONLY		cldtrend	AV:205	-99 to 99	CLDTREND
Cooling Fan-Off Delay	R/W	sec	cool_fod	AV:207	0 to 600	COOL_FOD
Damper Actual Position	R/W	%	oa_dmpr_pos	AV:2022	0 to 1	DAMPPOS
Damper SAT deadband	R/W	°F	t24satdb	AV:308	0 to 20	T24SATDB
Delay On Low SST Check	R/W	sec	ststckdly	AV:300	0 to 300	SSTCKDLY
Diff. Dry Bulb Deadband	R/W	°F	oa_ra_diff_temp	AV:78	1.0f to 99.0f	OATRATDB
Differential Air Quality	READ ONLY	PPM	aq_diff	AV:195	-5000 to 5000	AQ_DIFF
Econ Damper Resets Count	READ ONLY		rs_damp	AV:102	0 to 65535	RS_DAMP
Econ Damper Run Hours	READ ONLY	hrs	hour_damp	AV:51	0 to 999999	HR_DAMP
Econ Max Damper Position	R/W	%	dampmax	AV:185	0 to 1	DAMPMAX
Econ Min at Max Fanspeed	R/W	%	minp_max	AV:318	0 to 1	MINP_MAX

APPENDIX E — BACNET POINTS LIST

Table Y — BACnet* AV Points List (cont)

POINT DESCRIPTION	POINT ACCESS	UNITS	BACNET OBJECT NAME	BACNET ID	VALUE RANGE	CCN POINT EQUIVALENT
Econo Actual Position	READ ONLY	%	dampact	AV:211	0 to 1	DAMPACT
Econo Commanded Position	R/W	%	dmpr_cmd	AV:4	0 to 1	DAMPCMD
Economizer Damper Starts	READ ONLY		st_damp	AV:139	0 to 999999	ST_DAMP
Economizer Position Test	R/W	%	s_damper	AV:118	0 to 1	S_DAMPER
Economizer Travel Time	R/W	sec	econotrsv	AV:226	5 to 300	ECONOTRV
Effective Deadband	R/W		effdb	AV:6007	0 to 55	EFFDB
Effective Demand Temp	READ ONLY	°F	temp_eff	AV:163	-40 to 245	TEMP_EFF
Effective Zone Setpoint	R/W	°F	effsp	AV:6006	55 to 90	EFFSP
Enthalpy Cross Deadband	R/W	BTU_LB	oa_ra_diff_enth	AV:77	0 to 20	OAERAEDB
Equipment Touch RH	R/W	%	EquipmentTouchRH	AV:1904	0 to 1	ETSPRH
Equipment Touch SPT	R/W	°F	EquipmentTouchSPT	AV:1902	-40 to 240	ETSPT
Fan Supply Air Temp	READ ONLY	°F	idf_sa_temp	AV:10	-40 to 245	FST
FBDH Low Set Point	R/W	°F delta	fbdlosp	AV:438	-20 to 0	FBDLO_SP
FBDH SAT Min value	R/W	°F	fbdh_sat	AV:436	35 to 80	FBDH_SAT
FBDH SAT Set Point	READ ONLY	°F	fbdsatsp	AV:441	0 to 240	FBDSATSP
FBDH SST Min value	R/W	°F	fbdh_sst	AV:437	10 to 60	FBDH_SST
Filter hour remaining	READ ONLY	hrs	filter_rntm	AV:2015	0 to 9999	FILTERLEFT
Free Cooling IDF Speed	R/W	%	fspd_free_cool	AV:230	0 to 1	FSPD_FCL
Free Cooling Max OAT	R/W	°F	max_free_cl_temp	AV:67	0 to 90	MAXFREET
Free Cooling Min Temp	R/W	°F	min_free_cl_temp	AV:71	-30 to 70	MINFREET
Free Cooling Reset Count	READ ONLY		rs_freec	AV:104	0 to 65535	RS_FREEC
Free Cooling Run Hours	READ ONLY	hrs	hour_free_cl	AV:53	0 to 999999	HR_FREEC
Free Cooling Starts	READ ONLY		st_freec	AV:141	0 to 999999	ST_FREEC
Full Load Resets Count	READ ONLY		rs_fload	AV:103	0 to 65535	RS_FLOAD
Heat Demand Level Up	R/W	°F	hadmd_lup	AV:239	-2 to 2	HDMD_LUP
Heat DMD Offset level 1	R/W	°F	hdlm_level1	AV:403	0 to 40	HTDOLEV1
Heat DMD Offset level 2	R/W	°F	hdlm_level2	AV:404	0 to 40	HTDOLEV2
Heat DMD Offset level 3	R/W	°F	hdlm_level3	AV:405	0 to 40	HTDOLEV3
Heat Minimum Off Time	R/W	sec	h_minoff	AV:235	60 to 600	H_MINOFF
Heat Minimum On Time	R/W	sec	h_minon	AV:236	60 to 600	H_MINON
Heat Mode Select T.guard	READ ONLY	sec	ht_sel_timeguard	AV:45	0 to 65535	HEATMSTG
Heat Setpoint in Effect	READ ONLY	°F	hsp_eff	AV:243	40 to 80	HSP_EFF
Heat Shed 1 demand band	R/W		heatsh1	AV:6011	0 to 55	HEATSH1
Heat Shed 2 demand band	R/W		heatsh2	AV:6012	0 to 55	HEATSH2
Heat Shed 3 demand band	R/W		heatsh3	AV:6013	0 to 55	HEATSH3
Heat Space Demand Trend	READ ONLY		htdtrend	AV:244	-99 to 99	HTDTREND
Heat Stage 1 Reset Count	READ ONLY		rs_htr_1	AV:106	0 to 65535	RS_HTR_1
Heat Stage 1 Run Hours	READ ONLY	hrs	hour_ht_1	AV:54	0 to 999999	HR_HTR_1
Heat Stage 1 Starts	READ ONLY		st_htr_1	AV:142	0 to 999999	ST_HTR_1
Heat Stage 1 Timeguard	READ ONLY	sec	timgd_h1	AV:173	0 to 600	TIMGD_H1
Heat Stage 2 Reset Count	READ ONLY		rs_htr_2	AV:107	0 to 65535	RS_HTR_2
Heat Stage 2 Run Hours	READ ONLY	hrs	hour_ht_2	AV:55	0 to 999999	HR_HTR_2
Heat Stage 2 Starts	READ ONLY		st_htr_2	AV:143	0 to 999999	ST_HTR_2
Heat Stage 2 Timeguard	READ ONLY	sec	timgd_h2	AV:50	0 to 600	TIMGD_H2
Heat-Cool Setpoint Gap	R/W	°F	hcsp_gap	AV:238	2 to 10	HCSP_GAP
Heating Fan-Off Delay	R/W	sec	heat_fod	AV:241	10 to 600	HEAT_FOD
Heating IDF Speed	R/W	%	fspd_heat	AV:232	0.2 to 1	FSPD_HT
Heating Lockout Temp	R/W	°F	oatlheat	AV:8033	40 to 125	OATLHEAT
Heating Space Demand	READ ONLY	°F delta	heat_dmd	AV:240	-100 to 100	HEAT_DMD
High Cool Demand On	R/W	°F	dmdhcon	AV:215	0.5 to 20	DMDHCON
High Cooling IDF Speed	R/W	%	fspd_high_cool	AV:231	0.2 to 1	FSPD_HCL
High FreeCool SAT Setpnt	R/W	°F	high_cool_sasp	AV:237	40 to 80	HCSASP
High Heat Demand On	R/W	°F	dmdhhon	AV:217	0.5 to 20	DMDHHON
HumidiMizer Level Test	R/W		s_hmzlev	AV:414	0 to 2	S_HMZLEV
IAQ Assigned Channel	R/W		iaq_channel	AV:7	0 to 3	IAQ_CHAN
IAQ DCV Curve - Pos 1	READ ONLY	%	aq_pos1	AV:196	0 to 1	AQ_POS1
IAQ DCV Curve - Pos 2	READ ONLY	%	aq_pos2	AV:197	0 to 1	AQ_POS2
IAQ DCV Curve - Pos 3	READ ONLY	%	aq_pos3	AV:198	0 to 1	AQ_POS3
IAQ DCV Curve - Speed 1	READ ONLY	%	aq_spd1	AV:199	0 to 1	AQ_SPD1
IAQ DCV Curve - Speed 2	READ ONLY	%	aq_spd2	AV:200	0 to 1	AQ_SPD2
IAQ DCV Curve - Speed 3	READ ONLY	%	aq_spd3	AV:201	0 to 1	AQ_SPD3

APPENDIX E — BACNET POINTS LIST

Table Y — BACnet* AV Points List (cont)

POINT DESCRIPTION	POINT ACCESS	UNITS	BACNET OBJECT NAME	BACNET ID	VALUE RANGE	CCN POINT EQUIVALENT
IAQ DCV Curve Offset	READ ONLY	%	iaq_offs	AV:245	0 to 1	IAQ_OFFS
IAQ Position at Max Fan	R/W	%	iaqminp	AV:246	0 to 1	IAQMINP
IAQ Purge Curve - Pos 1	READ ONLY	%	aqp_pos1	AV:358	0 to 1	AQP_POS1
IAQ Purge Curve - Pos 2	READ ONLY	%	aqp_pos2	AV:359	0 to 1	AQP_POS2
IAQ Purge Curve - Pos 3	READ ONLY	%	aqp_pos3	AV:360	0 to 1	AQP_POS3
IAQ Purge Curve - Speed1	READ ONLY	%	aqp_spd1	AV:361	0 to 1	AQP_SPD1
IAQ Purge Curve - Speed2	READ ONLY	%	aqp_spd2	AV:362	0 to 1	AQP_SPD2
IAQ Purge Curve - Speed3	READ ONLY	%	aqp_spd3	AV:363	0 to 1	AQP_SPD3
IAQ Purge Curve Offset	READ ONLY	%	aqp_offs	AV:364	0 to 1	AQP_OFFS
IAQ Sensor Value at 20mA	R/W	PPM	iaq_20ma	AV:12	0 to 5000	IAQ_20MA
IAQ Sensor Value at 4mA	R/W	PPM	iaq_4ma	AV:13	0 to 5000	IAQ_4MA
IDF Maximum Fan Speed	R/W	%	speed_max	AV:36	0.8 to 1	SPEEDMAX
IDF VFD Accel. Time	R/W	sec	ramp_up_time	AV:96	1 to 1800	RAMPUP_T
IDF VFD Actual Speed %	READ ONLY	%	mav	AV:174	-2 to 2	MAV
IDF VFD Alarm Word	READ ONLY		almerrc	AV:158	0 to 4294967295	ALMERRC
IDF VFD Auto Reset time	R/W	sec	arstrt_t	AV:160	0 to 600	ARSTRT_T
IDF VFD Comm time out	R/W	sec	cnt_t_out	AV:166	1 to 600	CNT_TOUT
IDF VFD Cumulative kWh	READ ONLY	KWH	kwhcntr	AV:171	0 to 65535	KWHCNTR
IDF VFD Current Limit	READ ONLY	%	curr_limit	AV:3	0 to 3	CURRLMT
IDF VFD DC Bus Voltage	READ ONLY	volts	dclnvolt	AV:168	0 to 65535	DCLNVOLT
IDF VFD Decel. Time	R/W	sec	ramp_down_time	AV:29	1 to 1800	RAMPDN_T
IDF VFD Heatsink Temp	READ ONLY	'F	htsinkt	AV:170	-198.4f to 500	HTSINKT
IDF VFD Max Reference	R/W	Hz	maxref	AV:68	-4999 to 4999	MAXREF
IDF VFD Min Reference	R/W	Hz	minref	AV:72	-4999 to 4999	MINREF
IDF VFD Nom. Motor Amps	R/W	Amps	mot_current	AV:16	0 to 999	MOTCUR
IDF VFD Nom. Motor Freq	R/W	Hz	mot_frequency	AV:17	20 to 400	MOTFREQ
IDF VFD Nom. Motor RPM	R/W	RPM	mot_nom_Speed	AV:18	100 to 60000	MOTNOMSP
IDF VFD Nom. Motor Volts	R/W	volts	mot_volt	AV:20	50 to 1000	MOTVOLT
IDF VFD Output Amps	READ ONLY	Amps	vfd_motor_amps	AV:3002	0 to 655.35	OUTMCUR
IDF VFD Output Freq.	READ ONLY	Hz	vfd_out_frequency	AV:3003	0 to 6553.5	OUTMFREQ
IDF VFD Output Power hp	READ ONLY		vfd_out_hp	AV:3005	0 to 1000	OUTPWRHP
IDF VFD Output Power kW	READ ONLY	KW	vfd_out_kw	AV:3006	0 to 1000	OUTPWRKW
IDF VFD Output Voltage	READ ONLY	volts	vfd_out_voltage	AV:3004	0 to 65535	OUTMVOLT
IDF VFD Reference Speed	READ ONLY	%	vfd_speed_req	AV:3007	0.0f to 1.0f	REFSPEED
Indoor Air Quality Level	R/W	PPM	iaq	AV:1009	0 to 5000	IAQ
Indoor Fan Reset Count	READ ONLY		rs_idf	AV:108	0 to 65535	RS_IDF
Indoor Fan Run Hours	READ ONLY	hrs	hour_idf	AV:56	0 to 999999	HR_IDF
Indoor Fan Speed Test	R/W	%	s_idfspd	AV:119	0 to 1	S_IDFSPD
Indoor Fan Starts	READ ONLY		st_idf	AV:144	0 to 999999	ST_IDF
LA Dehum SDT SP Lev 1	R/W	'F	lhsdtsp1	AV:430	60 to 120	LHSDTSP1
LA Dehum SDT SP Lev 2	R/W	'F	lhsdtsp2	AV:431	60 to 120	LHSDTSP2
LA Dehum SDT SP Lev 3	R/W	'F	lhsdtsp3	AV:432	60 to 120	LHSDTSP3
ldv_a Resets Count	READ ONLY		rs_ldv_a	AV:388	0 to 65535	RS_LDV_A
LDV_A Run Hours	READ ONLY	hrs	hour_ldv_a	AV:380	0 to 999999	HR_LDV_A
ldv_a Starts	READ ONLY		st_ldv_a	AV:384	0 to 999999	ST_LDV_A
Linkage CCN Bus number	R/W		lnk_supb	AV:272	0 to 239	LNK_SUPB
Linkage CCN element #	R/W		lnk_supe	AV:273	0 to 239	LNK_SUPE
Linkage Cooling Required	READ ONLY	°F	lnk_creq	AV:257	0 to 30	LNK_CREQ
Linkage Damper Position	READ ONLY	%	lnk_dpos	AV:258	0 to 1	LNK_DPOS
Linkage Equipment Mode	READ ONLY		lnk_mode	AV:261	0 to 8	LNK_MODE
Linkage Heating Required	READ ONLY	°F	lnk_hreq	AV:259	0 to 30	LNK_HREQ
Linkage Maximum Airflow	READ ONLY		lnk_mair	AV:260	0 to 5000	LNK_MAIR
Linkage Optimal Start	READ ONLY	min	lnk_opst	AV:267	0 to 180	LNK_OPST
Linkage Space Air Qual.	READ ONLY	PPM	lnk_siaq	AV:270	0 to 2000	LNK_SIAQ
Linkage Space RH	READ ONLY	%	lnk_sprh	AV:271	0 to 1	LNK_SPRH
Linkage Start Bias time	R/W	min	lnk_sbt	AV:269	0 to 180	LNK_SBT
Linkage static pressure	READ ONLY	IN_H2O	link_ahu_static	AV:312	-5 to 5	LNK_DSP
Linkage Supply air temp	READ ONLY	°F	lnk_sat	AV:268	-40 to 240	LNK_SAT
Local Std Time offset	R/W	min	utc_ofst	AV:191	-780 to 780	UTC_OFST
Low Ambient Ctrl Status	R/W		lactrlst	AV:434	0 to 3	LACTRLST
Low Ambient Dehum Lev 1	R/W	'F	lahtemp1	AV:427	40 to 125	LAHTEMP1

APPENDIX E — BACNET POINTS LIST

Table Y — BACnet* AV Points List (cont)

POINT DESCRIPTION	POINT ACCESS	UNITS	BACNET OBJECT NAME	BACNET ID	VALUE RANGE	CCN POINT EQUIVALENT
Low Ambient Dehum Lev 2	R/W	'F	lahtemp2	AV:428	40 to 125	LAHTEMP2
Low Ambient Dehum Lev 3	R/W	'F	lahtemp3	AV:429	40 to 125	LAHTEMP3
Low Ambient Temperature	R/W	'F	la_temp	AV:253	0 to 80	LA_TEMP
Low Charge Disable Temp	R/W	°F	loch_lot	AV:276	-40 to 50	LOCH_LOT
Low Cool Demand Off	R/W	°F	dmdlcoff	AV:218	-1 to 2	DMDLCOFF
Low Cool Demand On	R/W	°F	dmdlcon	AV:219	-1 to 2	DMDLCON
Low Cool Lockout Temp	R/W	°F	lcllocksp	AV:8031	-20 to 60	LCLOCKSP
Low Cooling IDF Speed	R/W	%	fspd_low_cool	AV:233	0.2 to 1	FSPD_LCL
Low Heat Demand Off	R/W	°F	dmdlhoff	AV:220	-1 to 2	DMDLHOFF
Low Heat Demand On	R/W	°F	dmdlhon	AV:221	-1 to 2	DMDLHON
Low Refrig Charge Level	R/W	PSI	locharge	AV:277	0 to 150	LOCHARGE
LowFree Cool SAT Setpnt	R/W	°F	low_cool_sasp	AV:254	40 to 80	LCSASP
Max Allowed Cool Stages	R/W		max_cstgs	AV:278	0 to 3	MAXCSTGS
Max Allowed Heat Stages	R/W		max_hstgs	AV:279	0 to 2	MAXHSTGS
Max Enthalpy OA limit	R/W	BTU_LB	max_enth	AV:44	1.0f to 99.0f	FREEMAXE
Max Fan Speed Run Hours	READ ONLY	hrs	hour_max_fan	AV:57	0 to 999999	HR_MAXF
Max IDF Spd Resets Count	READ ONLY		rs_maxf	AV:109	0 to 65535	RS_MAXF
Max IDF Speed Starts	READ ONLY		st_maxf	AV:145	0 to 999999	ST_MAXF
Med Cooling IDF Speed	R/W	%	fspd_medium_cool	AV:234	0.2 to 1	FSPD_MCL
Med. Cool Lockout Temp	R/W	'F	mclocksp	AV:8032	-20 to 60	MCLOCKSP
Medium Cool Demand On	R/W	°F	dmdmcon	AV:223	0.5 to 20	DMDMCON
Min Pos - Default Pos 1	READ ONLY	%	mp_dpos1	AV:319	0 to 1	MP_DPOS1
Min Pos - Default Pos 2	READ ONLY	%	mp_dpos2	AV:290	0 to 1	MP_DPOS2
Min Pos - Default Pos 3	READ ONLY	%	mp_dpos3	AV:320	0 to 1	MP_DPOS3
Min Pos - Default Speed1	READ ONLY	%	mp_dspd1	AV:321	0 to 1	MP_DSPD1
Min Pos - Default Speed2	READ ONLY	%	mp_dspd2	AV:322	0 to 1	MP_DSPD2
Min Pos - Default Speed3	READ ONLY	%	ms_dspd3	AV:323	0 to 1	MP_DSPD3
Min Pos - User Pos 1	R/W	%	mp_upos1	AV:329	0 to 1	MP_UPOS1
Min Pos - User Pos 2	R/W	%	mp_upos2	AV:330	0 to 1	MP_UPOS2
Min Pos - User Pos 3	R/W	%	mp_upos3	AV:331	0 to 1	MP_UPOS3
Min Pos - User Speed 1	R/W	%	mp_uspd1	AV:222	0 to 1	MP_USPD1
Min Pos - User Speed 2	R/W	%	mp_uspd2	AV:5	0 to 1	MP_USPD2
Min Pos - User Speed 3	R/W	%	mp_uspd3	AV:138	0 to 1	MP_USPD3
Min Pos Curve - Pos 1	READ ONLY	%	mp_pos1	AV:324	0 to 1	MP_POS1
Min Pos Curve - Pos 2	READ ONLY	%	mp_pos2	AV:325	0 to 1	MP_POS2
Min Pos Curve - Pos 3	READ ONLY	%	mp_pos3	AV:326	0 to 1	MP_POS3
Min Pos Curve - Speed 1	READ ONLY	%	mp_spd1	AV:327	0 to 1	MP_SPD1
Min Pos Curve - Speed 2	READ ONLY	%	mp_spd2	AV:15	0 to 1	MP_SPD2
Min Pos Curve - Speed 3	READ ONLY	%	mp_spd3	AV:328	0 to 1	MP_SPD3
Min Position in Effect	R/W	%	min_pos	AV:412	0 to 1	MIN_POS
Mins until next occupied	READ ONLY	min	mintiloc	AV:175	-1 to 10080	MINTILOC
Momentary Setpoint Adj	R/W	°F delta	moset	AV:6022	0 to 20	MOSET
Momentary TLO Adjustment	R/W	sec	motlo	AV:6025	0 to 14400	MOTLO
Network IAQ Value	R/W	PPM	iaq_net	AV:7001	0 to 5000	IAQ_NET
Network OACFM Value	R/W	CFM	ocfm_net	AV:371	0 to 5000	OCFM_NET
Network OAQ Value	R/W	PPM	oaq_net	AV:7002	0 to 5000	OAQ_NET
Network OARH Value	R/W	%	oarh_net	AV:7003	0 to 1	OARH_NET
Network OAT Value	R/W	°F	oat_net	AV:7007	-40 to 245	OAT_NET
Network RARH Value	R/W	%	rarh_net	AV:7004	0 to 1	RARH_NET
Network Return Air Temp	R/W	°F	rat_net	AV:7005	-40 to 245	RAT_NET
Network Space Temp Value	R/W	°F	spt_net	AV:7006	-40 to 245	SPT_NET
Network SPRH Value	R/W	%	sprh_net	AV:376	0 to 1	SPRH_NET
Next Occupied Time	READ ONLY	min	nxtoctim	AV:176	-1 to 10080	NXTOCTIM
Next Unoccupied Time	READ ONLY	min	nxntuntim	AV:177	-1 to 10079	NXTUNTIM
No IGC IFO input Timeout	R/W	min	no_igctm	AV:281	0 to 60	NO_IGCTM
Number of Active Alerts	READ ONLY		num_active_alerts	AV:334	0 to 100	NUMALRTS
Number of Active Faults	READ ONLY		num_active_faults	AV:335	0 to 100	NUMFLTS
Number Of Cooling Stages	READ ONLY		numcstgs	AV:283	0 to 3	NUMCSTGS
Number of Fan Speeds	R/W		numfspds	AV:449	2 to 3	NUMFSPDS
Number Of Heating Stages	R/W		numhstgs	AV:284	0 to 2	NUMHSTGS
Number of ODF Outputs	R/W		num_odf	AV:75	0 to 3	NUM_ODF

APPENDIX E — BACNET POINTS LIST

Table Y — BACnet* AV Points List (cont)

POINT DESCRIPTION	POINT ACCESS	UNITS	BACNET OBJECT NAME	BACNET ID	VALUE RANGE	CCN POINT EQUIVALENT
OA Quality Level	R/W	PPM	oaq	AV:1012	0 to 5000	OAQ
OA Relative Humidity	R/W	%	oarh	AV:1022	0 to 1	OARH
OACFM Assigned Channel	R/W		ocfmchan	AV:370	0 to 3	OCFMCHAN
OACFM at 4MA	R/W	CFM	ocfm_4ma	AV:369	0 to 5000	OCFM_4MA
OACFM Value at 20mA	R/W	CFM	ocfm20ma	AV:417	0 to 5000	OCFM20MA
OAQ Assigned Channel	R/W		oaq_channel	AV:426	0 to 3	OAQ_CHAN
OARH Assigned Channel	R/W		oarh_channel	AV:23	0 to 3	OARHCHAN
OARH Sensor Val. at 20mA	R/W	%	oarh_20ma	AV:22	0.6 to 1.0	OARH20MA
OARH Sensor Value at 4mA	R/W	%	oarh_4ma	AV:21	0 to 0.5	OARH_4MA
OATLimitForSupAirTemp	R/W	°F	oatstemp	AV:424	-40 to 125	OATSTEMP
Object instance for IAQ	R/W		objiaq	AV:8008	0 to 9999	OBJIAQ
Object instance for OAQ	R/W		objoaq	AV:8009	0 to 9999	OBJOAQ
Object instance for OARH	R/W		objoarh	AV:8011	0 to 9999	OBJOARH
Object instance for OAT	R/W		objoat	AV:8010	0 to 9999	OBJOAT
Object instance for RARH	R/W		objrarh	AV:8012	0 to 9999	OBJRARH
Object instance for RAT	R/W		objrat	AV:8013	0 to 9999	OBJRAT
Object instance for SPRH	R/W		objsprh	AV:8029	0 to 9999	OBJSPRH
Object instance for SPT	R/W		objsppt	AV:8014	0 to 9999	OBJSPPT
Occ Cooling Required	READ ONLY	°F	lnk_ocrq	AV:263	0 to 30	LNK_OCRQ
Occ Heating required	READ ONLY	°F	lnk_ohrq	AV:265	0 to 30	LNK_OHRQ
Occupied Cool Setpoint	R/W	°F	ocsp	AV:288	55 to 80	OCSP
Occupied Heat Setpoint	R/W	°F	ohsp	AV:289	55 to 80	OHSP
Occupied Setpoint Gap	R/W		odb	AV:6003	0 to 10	ODB
Occupied SPRH Setpoint	READ ONLY	%	sprh_osp	AV:367	0.10 to 1	SPRH_OSP
Occupied Zone Setpoint	R/W	°F	osp	AV:6002	40 to 80	OSP
ODF Control SDT SP	READ ONLY	°F	odfsdtsp	AV:433	-100 to 500	ODFSDTSP
ODF High Cool Speed	R/W	RPM	odf_hi_speed	AV:82	0 to 1200	ODFHCSPEED
ODF High Speed Time	R/W	sec	minodftm	AV:280	0 to 300	MINODFTM
ODF Low Cool Speed	R/W	RPM	odf_lo_speed	AV:83	0 to 1200	ODFLCSPD
ODF Maximum Speed	R/W	RPM	odf_max_speed	AV:86	0 to 1200	ODFMAXSP
ODF Med Cool Speed	R/W	RPM	odf_med_speed	AV:84	0 to 1200	ODFMCSPEED
ODF Minimum Speed	R/W	RPM	odf_min_speed	AV:85	0 to 1200	ODFMINSPEED
ODF Signal1 Resets Count	READ ONLY		rs_odf1	AV:110	0 to 65535	RS_ODF1
ODF Signal2 Resets Count	READ ONLY		rs_odf2	AV:111	0 to 65535	RS_ODF2
ODF Signal3 Resets Count	READ ONLY		rs_odf3	AV:112	0 to 65535	RS_ODF3
ODF Spd Sig 1 Run Hours	READ ONLY	hrs	hour_odf1	AV:58	0 to 999999	HR_ODF1
ODF Spd Sig 2 Run Hours	READ ONLY	hrs	hour_odf2	AV:59	0 to 999999	HR_ODF2
ODF Spd Sig 3 Run Hours	READ ONLY	hrs	hour_odf3	AV:60	0 to 999999	HR_ODF3
ODF Spd Signal 1 Starts	READ ONLY		st_odf1	AV:302	0 to 999999	ST_ODF1
ODF Spd Signal 2 Starts	READ ONLY		st_odf2	AV:146	0 to 999999	ST_ODF2
ODF Spd Signal 3 Starts	READ ONLY		st_odf3	AV:147	0 to 999999	ST_ODF3
ODF Speed Signal Output1	READ ONLY	RPM	odf1_rpm	AV:26	0 to 1200	ODF1SPD
ODF Speed Signal Output2	READ ONLY	RPM	odf2_rpm	AV:27	0 to 1200	ODF2SPD
ODF Speed Signal Output3	READ ONLY	RPM	odf3_rpm	AV:28	0 to 1200	ODF3SPD
Outdoor Air Enthalpy	R/W	BTU_LB	oa_enth	AV:76	-9.6f to 334.2f	OA_ENTH
outdoor Air in CFM	R/W	CFM	oacfm	AV:416	0 to 5000	OACFM
Outdoor Air Temp Sensor	READ ONLY	°F	oat_loc	AV:286	-40 to 245	OAT_LOC
Outdoor Air Temperature	R/W	°F	oa_temp	AV:1003	-40 to 245	OAT
Outdoor Fan 1 speed test	R/W	RPM	s_odfsp1	AV:120	0 to 1200	S_ODFSP1
Outdoor Fan 2 speed test	R/W	RPM	s_odfsp2	AV:121	0 to 1200	S_ODFSP2
Outdoor Fan 3 speed test	R/W	RPM	s_odfsp3	AV:122	0 to 1200	S_ODFSP3
P.Exhaust 1 Curve Offset	READ ONLY	%	pe1_offs	AV:317	0 to 1	PE1_OFFS
P.Exhaust 1 Resets Count	READ ONLY		rs_pe_1	AV:113	0 to 65535	RS_PE_1
P.Exhaust 2 Curve Offset	READ ONLY	%	pe2_offs	AV:229	0 to 1	PE2_OFFS
P.Exhaust 2 Resets Count	READ ONLY		rs_pe_2	AV:114	0 to 65535	RS_PE_2
PE Stage 1 At Max Speed	R/W	%	pe1_pmax	AV:343	0 to 1	PE1_PMAX
PE Stage 2 At Max Speed	R/W	%	pe2_pmax	AV:344	0 to 1	PE2_PMAX
PE Turn Off Dead band	R/W	%	pe_offdb	AV:316	0 to 1	PE_OFFDB
PE1 Assigned Relay	R/W		pe1_channel	AV:365	0 to 2	PE1_CHAN
PE2 Assigned Relay	R/W		pe2_channel	AV:366	0 to 2	PE2_CHAN
Pilot Space Temp Value	R/W	°F	space_temp	AV:2007	-40 to 245	SPT

APPENDIX E — BACNET POINTS LIST

Table Y — BACnet* AV Points List (cont)

POINT DESCRIPTION	POINT ACCESS	UNITS	BACNET OBJECT NAME	BACNET ID	VALUE RANGE	CCN POINT EQUIVALENT
Power Cycle Counts	READ ONLY		st_por	AV:150	0 to 999999	ST_POR
Power Cycle Resets Count	READ ONLY		rs_por	AV:115	0 to 65535	RS_POR
Power Exhaust 1 - Pos 1	READ ONLY	%	pe1_pos1	AV:345	0 to 1	PE1_POS1
Power Exhaust 1 - Pos 2	READ ONLY	%	pe1_pos2	AV:346	0 to 1	PE1_POS2
Power Exhaust 1 - Pos 3	READ ONLY	%	pe1_pos3	AV:347	0 to 1	PE1_POS3
Power Exhaust 1 - Speed1	READ ONLY	%	pe1_spd1	AV:348	0 to 1	PE1_SPD1
Power Exhaust 1 - Speed2	READ ONLY	%	pe1_spd2	AV:349	0 to 1	PE1_SPD2
Power Exhaust 1 - Speed3	READ ONLY	%	pe1_spd3	AV:350	0 to 1	PE1_SPD3
Power Exhaust 1 Starts	READ ONLY		st_pe_1	AV:148	0 to 999999	ST_PE_1
Power Exhaust 2 - Pos 1	READ ONLY	%	pe2_pos1	AV:351	0 to 1	PE2_POS1
Power Exhaust 2 - Pos 2	READ ONLY	%	pe2_pos2	AV:352	0 to 1	PE2_POS2
Power Exhaust 2 - Pos 3	READ ONLY	%	pe2_pos3	AV:353	0 to 1	PE2_POS3
Power Exhaust 2 - Speed1	READ ONLY	%	pe2_spd1	AV:354	0 to 1	PE2_SPD1
Power Exhaust 2 - Speed2	READ ONLY	%	pe2_spd2	AV:355	0 to 1	PE2_SPD2
Power Exhaust 2 - Speed3	READ ONLY	%	pe2_spd3	AV:356	0 to 1	PE2_SPD3
Power Exhaust 2 Starts	READ ONLY		st_pe_2	AV:149	0 to 999999	ST_PE_2
Power Exhaust1 Run Hours	READ ONLY	hrs	hour_pe_1	AV:61	0 to 999999	HR_PE_1
Power Exhaust2 Run Hours	READ ONLY	hrs	hour_pe_2	AV:62	0 to 999999	HR_PE_2
Preocc Purge Duration	R/W	min	iaqptime	AV:252	5 to 120	IAQPTIME
Preocc Purge Lockout OAT	R/W	°F	iaqp_la	AV:248	0 to 70	IAQP_LA
Previous Unoccupied Time	READ ONLY	min	prvuntim	AV:182	-1 to 10079	PRVUNTIM
RA Relative Humidity	R/W	%	rarh	AV:30	0 to 1	RARH
RARH Assigned Channel	R/W		rarh_channel	AV:33	0 to 3	RARHCHAN
RARH Sensor Value @ 20mA	R/W	%	rarh_20ma	AV:32	0.0f to 1	RARH20MA
RARH Sensor Value at 4mA	R/W	%	rarh_4ma	AV:31	0 to 1.0f	RARH_4MA
rdv_a Resets Count	READ ONLY		rs_rdv_a	AV:389	0 to 65535	RS_RDV_A
RDV_A Run Hours	READ ONLY	hrs	hour_rdv_a	AV:381	0 to 999999	HR_RDV_A
rdv_a Starts	READ ONLY		st_rdv_a	AV:385	0 to 999999	ST_RDV_A
Reheat lev 1 Rst Count	READ ONLY		rs_rqh1	AV:390	0 to 65535	RS_RQHL1
Reheat lev 2 Rst Count	READ ONLY		rs_rqh2	AV:391	0 to 65535	RS_RQHL2
Reheat level 1 Run Hrs	READ ONLY	hrs	hour_rqh1	AV:382	0 to 999999	HR_RQHL1
Reheat level 1 Starts	READ ONLY		st_rqh1	AV:386	0 to 999999	ST_RQHL1
Reheat level 2 Run Hrs	READ ONLY	hrs	hour_rqh2	AV:383	0 to 999999	HR_RQHL2
Reheat level 2 Starts	READ ONLY		st_rqh2	AV:387	0 to 999999	ST_RQHL2
Req Compr DehumStgs	R/W		reqdstgs	AV:413	0 to 10	REQDSTGS
Requested Cooling Stages	READ ONLY		req_cstgs	AV:292	0 to 3	REQCSTGS
Requested Damper Pos	R/W	%	dmpr_req_pos	AV:4006	0 to 1	DAMPRQ
Requested Heating Stages	READ ONLY		reqhstgs	AV:293	0 to 2	REQHSTGS
Requested IDF Speed	READ ONLY	%	req_fan_spd	AV:35	0 to 1	RQFANSPD
Reset Device	R/W		resetdev	AV:184	0 to 1	RESETDEV
Restore Completion Time	READ ONLY		rstcomtm	AV:337	0 to 65535	RSTCOMTM
Return Air Enthalpy	R/W	BTU_LB	ra_enth	AV:95	-9.6f to 334.2f	RA_ENTH
Return Air Temp Sensor	READ ONLY	°F	rat_loc	AV:291	-40 to 245	RAT_LOC
Return Air Temperature	R/W	°F	ra_temp	AV:1010	-40 to 245	RAT
RLV_A Resets Count	READ ONLY		rs_rlv_a	AV:456	0 to 65535	RS_RLV_A
RLV_A Starts	READ ONLY		st_rlv_a	AV:460	0 to 999999	ST_RLV_A
SA Tempering Set point	R/W	°F	sup_air_temp_setpt	AV:411	-20 to 60	SATEMPSP
Service Test Reset Count	READ ONLY		rs_stest	AV:116	0 to 65535	RS_STEST
Service Test Run Hours	READ ONLY	hrs	hour_serv_tst	AV:63	0 to 999999	HR_STEST
Service Test Starts	READ ONLY		st_stest	AV:151	0 to 999999	ST_STEST
Setpoint adjustment	R/W	°F delta	setadj	AV:6021	0 to 1	SETADJ
Single Zone Setpoint	R/W	°F	zonespt	AV:6001	55 to 80	ZONESPT
Software Build Time	READ ONLY		fw_bldtm	AV:169	0 to 4294967295	FW_BLDTM
Space Cooling Demand	READ ONLY	°F delta	cool_dmd	AV:206	-100 to 100	COOL_DMD
Space Demand Time Guard1	R/W	sec	tdmd_tg1	AV:311	60 to 600	TDMD_TG1
Space Demand Time Guard2	R/W	sec	tdmd_tg2	AV:186	0 to 600	TDMD_TG2
Space Demand Time Guard3	R/W	min	tdmd_tg3	AV:187	5 to 120	TDMD_TG3
Space RH	R/W	%	space_rh	AV:1011	0 to 1	SPRH
Space RH Deadband	R/W	%	sprh_db	AV:368	0 to 1	SPRH_DB
Space Temperature	R/W	°F	space_t	AV:296	-40 to 245	SPACE_T
Space Temperature Offset	R/W	°F delta	stpt_adj	AV:1006	-10 to 10	SPTO

APPENDIX E — BACNET POINTS LIST

Table Y — BACnet* AV Points List (cont)

POINT DESCRIPTION	POINT ACCESS	UNITS	BACNET OBJECT NAME	BACNET ID	VALUE RANGE	CCN POINT EQUIVALENT
Space Temperature Sensor	READ ONLY	°F	spt_loc	AV:297	-40 to 245	SPT_LOC
SPRH Assigned Channel	R/W		sprhchan	AV:372	0 to 3	SPRHCHAN
SPRH Sensor Value @ 20mA	R/W	%	sprh_20ma	AV:373	0.6 to 1	SPRH20MA
SPRH Sensor Value at 4mA	R/W	%	sprh_4ma	AV:375	0 to 0.5	SPRH_4MA
SPT Offset Range (+/-)	R/W	°F	spto_rng	AV:298	0 to 5	SPTO_RNG
SPT Offset Total diff	READ ONLY	°F delta	sptodiff	AV:6020	0 to 20	SPTODIFF
Std Barometric Pressure	R/W	IN_HG_OF_KPAG	std_barp	AV:303	10 to 35	STD_BARP
Supply Air Temp Trend	READ ONLY		sattrend	AV:342	-285 to 285	SATTREND
Supply Air Temperature	READ ONLY	°F	sa_temp	AV:1008	-40 to 245	SAT
System Demand	READ ONLY		sys_demand	AV:37	0 to 255	SYS_DMD
System Demand Alert	R/W		sys_dmd_alert	AV:227	0 to 65535	SYSDMDAT
System ODF speed test	R/W	RPM	s_odfspd	AV:123	0 to 1200	S_ODFSPD
System Touch AI for SPRH	R/W		aistsprh	AV:8027	0 to 9999	AISTSPRH
System Touch AI for SPT	R/W		aistspt	AV:8026	0 to 9999	AISTSPPT
System Touch Device Inst	R/W		devst	AV:8024	0 to 4194303	DEVST
System Touch Poll Rate	R/W		pollst	AV:8025	10 to 60	POLLST
System Touch RH Value	R/W	%	strh_net	AV:8022	0 to 1	STRH_NET
System Touch Temp Value	R/W	°F	stst_net	AV:8023	-40 to 245	STST_NET
T24 Heat/Cool End Delay	R/W	min	t24chdly	AV:305	0 to 60	T24CHDLY
T24 Min Diff in RAT-OAT	R/W	°F	t24ratdf	AV:307	5 to 20	T24RATDF
T24 Test Maximum Pos	R/W	%	t24tstmx	AV:310	0.0f to 1.0f	T24TSTMX
T24 Test Minimum Pos	R/W	%	t24tstmn	AV:309	0.0f to 1.0f	T24TSTMN
T24Econ Min Move for SAT	R/W	%	t24ecsts	AV:306	0.1 to 0.2	T24ECSTS
Timed Override Duration	R/W	hrs	otl_cfg	AV:179	0 to 4	OTL_CFG
Timed Override Hours	R/W	min	ovr_ext	AV:180	0 to 240	OVR_EXT
TLO cancel	R/W	sec	tlocan	AV:6029	0 to 10	TLOCAN
TLO limit	R/W	sec	tlolim	AV:6027	0 to 14400	TLOLIM
TLO Time Remaining	READ ONLY	sec	tlorem	AV:6028	0 to 14400	TLOREM
UFC PreOcc Time	R/W	min	ufctime	AV:105	1 to 999	UFCTIME
Unit Full Load Run Hours	READ ONLY	hrs	hour_full_id	AV:52	0 to 999999	HR_FLOAD
Unit Full Load Starts	READ ONLY		st_fload	AV:140	0 to 999999	ST_FLOAD
Unit Startup Delay	R/W	sec	startdly	AV:153	10 to 600	STARTDLY
Unocc Free Cool Low Temp	R/W	°F	oatlufc	AV:287	-30.0f to 70.0f	OATLUFC
Unoccupied Cool Setpoint	R/W	°F	ucsp	AV:8	65 to 95	UCSP
Unoccupied Heat Setpoint	R/W	°F	uhsp	AV:178	40 to 80	UHSP
Unoccupied Setpoint Gap	R/W		udb	AV:6004	0 to 55	UDB
Unoccupied SPRH Setpoint	READ ONLY	%	sprh_usp	AV:461	0.10 to 1	SPRH_USP
UnoccupiedZone Setpoint	R/W	°F	usp	AV:6005	40 to 95	USP
User Min Pos Pnt 1 Valid	READ ONLY		mp_upt1	AV:332	0 to 1	MP_UPT1
User Min Pos Pnt 2 Valid	READ ONLY		mp_upt2	AV:333	0 to 1	MP_UPT2
User Min Pos Pnt 3 Valid	READ ONLY		mp_upt3	AV:214	0 to 1	MP_UPT3
User Password	R/W		password	AV:181	0 to 9999	PASSWORD
Value of Prime variable	READ ONLY		prime_v	AV:39	-40 to 245	PRIME_V
Vent IDF Resets Count	READ ONLY		rs_ventf	AV:117	0 to 65535	RS_VENTF
Vent IDF Run Hours	READ ONLY	hrs	hour_vent_fan	AV:64	0 to 999999	HR_VENTF
Ventilation Fan Starts	READ ONLY		st_ventf	AV:152	0 to 999999	ST_VENTF
Ventilation Only IDF Spd	R/W	%	idf_vent_speed	AV:9	0 to 1	FSPDVENT
Zone Sensor 1 Address	R/W		zsaddr1	AV:8034	0x00 to 0xFF	ZSADDR1
Zone Sensor 2 Address	R/W		zsaddr2	AV:8035	0x00 to 0xFF	ZSADDR2
Zone sensor 3 address	R/W		zsaddr3	AV:8036	0x00 to 0xFF	ZSADDR3
Zone sensor 4 address	R/W		zsaddr4	AV:8037	0x00 to 0xFF	ZSADDR4
Zone sensor 5 address	R/W		zsaddr5	AV:8038	0x00 to 0xFF	ZSADDR5
ZS Zone Temp	R/W	°F	ZSZoneTemp	AV:1905	-40 to 245	ZSZT

* BACnet is a registered trademark of ASHRAE (American Society of Heating, Refrigerating, and Air-Conditioning Engineers).

APPENDIX E — BACNET POINTS LIST

Table Z — BACnet* BV Points List

POINT DESCRIPTION	POINT ACCESS	UNITS	BACNET OBJECT NAME	BACNET ID	VALUE RANGE	CCN POINT EQUIVALENT
IDF VFD Hand Fault	R/W		f_vfdhnd	BV:233	0 to 1	
IDF VFD Lockout FitActv	R/W		f_vfdlo	BV:234	0 to 1	
IDF VFD Loss of Comm	R/W		f_idfcom	BV:229	0 to 1	
A051 Cmp off expected ON	R/W		a_caoff	BV:181	0 to 1	
Act Mech Disconnect Alrt	R/W		a_dnmemd	BV:218	0 to 1	
Air Quality CO2 Alerts	R/W		co2s_al	BV:307	0 to 1	CO2S_AL
Alarm Output Relay State	R/W		equip_alarm	BV:7048	0 to 1	ALMOUT
Alarm Output Relay Test	R/W		s_alarm	BV:70	0 to 1	S_ALARM
Alarm Reporting Enable	R/W		ALARMEN	BV:27	0 to 1	ALARMEN
ALC Auto Id Scheme	R/W		auid	BV:106	0 to 1	AUID
All Heat Stages Lockout	R/W		allhtloc	BV:122	0 to 1	ALLHTLOC
AUTO INDEPENDENT TEST	R/W		autoindp	BV:163	0 to 1	AUTOINDP
BACnet BMS Schedule	READ ONLY		bms_sced	BV:108	0 to 1	BMS_SCED
BACnet ID Auto ID	R/W		bac_auid	BV:107	0 to 1	BAC_AUID
BACnetCal Object Status	READ ONLY		calobjst	BV:110	0 to 1	CALOBJST
Bad DD Point-OutOfRange	R/W		f_bad_dd	BV:243	0 to 1	
CA1 DDF Fault	R/W		f_ca1ddf	BV:178	0 to 1	
CA1 FTP alert	R/W		a_ca1ftp	BV:182	0 to 1	
CA1 Rev Rotation alert	R/W		a_ca1rr	BV:179	0 to 1	
CA2 DDF fault	R/W		f_ca2ddf	BV:173	0 to 1	
CA2 FTP alert	R/W		a_ca2ftp	BV:177	0 to 1	
CA2 Rev Rotation alert	R/W		a_ca2rr	BV:174	0 to 1	
CCH Relay 1 State	READ ONLY		cch_relay	BV:3	0 to 1	CCHR1
Cir A DDF Fault	R/W		f_caddf	BV:168	0 to 1	
Cir A HDP alert	R/W		a_cahdp	BV:172	0 to 1	
Cir A HPS alert	R/W		a_cahps	BV:171	0 to 1	
Cir A LDP Alert	R/W		a_caldp	BV:236	0 to 1	
Cir A LSP Alert	R/W		a_calsp	BV:170	0 to 1	
Cir A Press Ratio Alert	R/W		a_capr	BV:169	0 to 1	
Cir A SSP out Rng Alert	R/W		a_badspa	BV:189	0 to 1	
Cir.A High Pressure Sw	READ ONLY		circa_hps	BV:4	0 to 1	CIRA_HPS
Circ A SDP Open Alert	R/W		a_opndpa	BV:191	0 to 1	
Circ A SDP range alert	R/W		a_baddpa	BV:183	0 to 1	
Circ A SDP Short Alert	R/W		a_shtdpa	BV:202	0 to 1	
Circ A SSP Open Alert	R/W		a_opnspa	BV:200	0 to 1	
Circuit A CMP A1 Loader	READ ONLY		cmpalena	BV:9	0 to 1	COMP_ALD
Circuit A Compressor 1	READ ONLY		cmpa1ena	BV:5	0 to 1	COMP_A1
Circuit A Compressor 2	READ ONLY		cmpa2ena	BV:6	0 to 1	COMP_A2
Circuit A Locked Out	READ ONLY		ciralock	BV:128	0 to 1	CIRALOCK
Circuit A SSP Shrt Alert	R/W		a_shtspa	BV:211	0 to 1	
Ckt-A low charge fault	R/W		f_caloch	BV:167	0 to 1	
Clear Alarm History	R/W		alarm_hist_clear	BV:32	0 to 1	ALHISCLR
Cmp Bump Loader Test	R/W		s_bmpald	BV:64	0 to 1	S_BMPALD
COFS Switch State	R/W		condensate_switch	BV:7028	0 to 1	COFS
Compressor A1 Available	READ ONLY		ca1_aval	BV:123	0 to 1	CA1_AVAL
Compressor A1 Locked Out	READ ONLY		ca1_lock	BV:124	0 to 1	CA1_LOCK
Compressor A2 Available	READ ONLY		ca2_aval	BV:125	0 to 1	CA2_AVAL
Compressor A2 Locked Out	READ ONLY		ca2_lock	BV:126	0 to 1	CA2_LOCK
Compressor Alerts	R/W		comp_alarm	BV:312	0 to 1	COMP_AL
Compressor Bump A1 Test	R/W		s_bmpa1	BV:71	0 to 1	S_BMPA1
Compressor Bump A2 Test	R/W		s_bmpa2	BV:72	0 to 1	S_BMPA2
CompressorStuck on Fault	R/W		f_cstuck	BV:241	0 to 1	
Condensate Ovrflow fault	R/W		f_cofs	BV:273	0 to 1	
CoolDemandLimiting	R/W		cooldmdLimit	BV:435	0 to 1	CDMLMOFF
Cooling Liq Valv Test	R/W		s_clv_a	BV:456	0 to 1	S_CLV_A
Cooling Liq Valve CirA	R/W		clv_a	BV:7052	0 to 1	CLV_A
Cooling W/Comp.A1 Test	R/W		s_coola1	BV:74	0 to 1	S_COOLA1
Cooling W/Comp.A2 Test	R/W		s_coola2	BV:75	0 to 1	S_COOLA2
Cooling W/Comp.ALD Test	R/W		s_colald	BV:79	0 to 1	S_COLALD
Crankcase Heater 1 test	R/W		s_cchr1	BV:73	0 to 1	S_CCHR1

APPENDIX E — BACNET POINTS LIST

Table Z — BACnet* BV Points List (cont)

POINT DESCRIPTION	POINT ACCESS	UNITS	BACNET OBJECT NAME	BACNET ID	VALUE RANGE	CCN POINT EQUIVALENT
Currently Occupied	R/W		occ_status	BV:2008	0 to 1	OCCUPIED
Damper fdbk out of range	R/W		a_badec1	BV:184	0 to 1	
Damper fdbk Short Alert	R/W		a_shtec1	BV:203	0 to 1	
Damper Not Mod Alert	R/W		a_dnm	BV:215	0 to 1	
Damper Stuck Closed Alrt	R/W		a_dnm_sc	BV:216	0 to 1	
Damper Stuck Open Alert	R/W		a_dnm_so	BV:217	0 to 1	
DD IDF High Speed Relay	READ ONLY		fspdhrly	BV:448	0 to 1	FSPDHRLY
DD IDF Low Speed Relay	READ ONLY		fspdlrly	BV:446	0 to 1	FSPDLRLY
DD IDF Med. Speed Relay	READ ONLY		fspdmrly	BV:447	0 to 1	FSPDMRLY
Diff. Dry Bulb Control	R/W		dif_db_ena	BV:41	0 to 1	DIFFBULB
Diff. Enthalpy Control	R/W		dif_enth_ena	BV:42	0 to 1	DIFFENTH
dirty filter alert	R/W		a_dfilt	BV:214	0 to 1	
Dirty Filter Alerts	R/W		filter_alarm	BV:7017	0 to 1	FILT_AL
Dmpr fdbk Open Cir Alert	R/W		a_opnec1	BV:192	0 to 1	
Dry Bulb Lockout	R/W		db_lock_out	BV:40	0 to 1	DBLOCK
DST allowed?	R/W		dst_cfg	BV:93	0 to 1	DST_CFG
DST currently active	READ ONLY		dst_actv	BV:92	0 to 1	DST_ACTV
Econ Damper Operational	READ ONLY		damp_good	BV:39	0 to 1	DAMPGOOD
Econo Actual Position	R/W		dmpr_err	BV:21	0 to 1	DAMP_ERR
Economizer Alerts	R/W		econ_alarm	BV:43	0 to 1	ECON_AL
Economizer Cooling	R/W		a_t24ewc	BV:226	0 to 1	
Economizer Installed?	R/W		econo_cfg	BV:131	0 to 1	ECONO
Economizer Not Cooling	R/W		a_t24enc	BV:224	0 to 1	
Enthalpy Lockout	R/W		enth_lock_out	BV:44	0 to 1	ENTHLOCK
Excess Outside Air Alert	R/W		a_t24eoa	BV:225	0 to 1	
Fan Off When Cmded On	R/W		f_idfoff	BV:230	0 to 1	
Fan On When Cmded Off	R/W		f_idfon	BV:231	0 to 1	
Fan On When Occupied	R/W		occupied_fan	BV:46	0 to 1	FANON_OC
fan status warning alert	R/W		a_idfwar	BV:219	0 to 1	
fbdh sat locked out	READ ONLY		fbdsatlo	BV:439	0 to 1	FBDSATLO
FBDH SST locked out	READ ONLY		fbdsstlo	BV:440	0 to 1	FBDSSTLO
Filter Status Switch	R/W		flt_status	BV:1016	0 to 1	FILTSTAT
Fire shutdown fault	R/W		f_fire	BV:242	0 to 1	
Fire Shutdown Switch	R/W		firedown	BV:112	0 to 1	FIREDOWN
FSPDHRLY IDF Test	R/W		s_fshrly	BV:464	0 to 1	S_FSHRLY
FSPDLRLY IDF Test	R/W		s_fslrly	BV:462	0 to 1	S_FSLRLY
FSPDMRLY IDF Test	R/W		s_fsmrly	BV:463	0 to 1	S_FSMRLY
FST Open Circuit Alert	R/W		a_opnfst	BV:193	0 to 1	
FST out of Range Alert	R/W		a_badfst	BV:185	0 to 1	
FST Sensor Error	R/W		fst_error	BV:49	0 to 1	FST_ERR
FST Short Circuit Alert	R/W		a_shtfst	BV:204	0 to 1	
General Status alert	R/W		a_gensw	BV:244	0 to 1	
General Status Alerts	R/W		gens_al	BV:309	0 to 1	GENS_AL
General Status fault	R/W		f_gensw	BV:265	0 to 1	
General Status Switch	R/W		gen_status	BV:50	0 to 1	GENSTAT
Hardware Failures Alerts	R/W		hw_al	BV:305	0 to 1	HW_AL
Heat Stage 1 Available	READ ONLY		ht1_aval	BV:16	0 to 1	HT1_AVAL
Heat Stage 1 Relay	READ ONLY		hs1	BV:10	0 to 1	HEAT_1
Heat Stage 2 Available	READ ONLY		ht2_aval	BV:17	0 to 1	HT2_AVAL
Heat Stage 2 Relay	READ ONLY		hs2	BV:11	0 to 1	HEAT_2
HeatDemandLimiting	R/W		heatdmdLimit	BV:370	0 to 1	HDMLMOFF
Heating Failure Alerts	R/W		heat_al	BV:306	0 to 1	HEAT_AL
Heating Stage 1 Test	R/W		s_heat1	BV:76	0 to 1	S_HEAT1
Heating Stage 2 Test	R/W		s_heat2	BV:77	0 to 1	S_HEAT2
Humidimizer Status	R/W		humz_en	BV:7010	0 to 1	HUMZ_EN
humidity ctrl is active	READ ONLY		humctrla	BV:423	0 to 1	
IAQ Open Circuit Alert	R/W		a_opniaq	BV:194	0 to 1	
IAQ override enable	R/W		iaq_override_en	BV:445	0 to 1	IAQOVREN
IAQ override sw state	R/W		iaqoverride_switch	BV:7030	0 to 1	IAQ_OVRS
IAQ Preoccupancy Purge	R/W		iaqpurge	BV:20	0 to 1	IAQPURGE
IAQ Sensor Error	R/W		iaq_err	BV:51	0 to 1	IAQ_ERR

APPENDIX E — BACNET POINTS LIST

Table Z — BACnet* BV Points List (cont)

POINT DESCRIPTION	POINT ACCESS	UNITS	BACNET OBJECT NAME	BACNET ID	VALUE RANGE	CCN POINT EQUIVALENT
IAQ Short Circuit Alert	R/W		a_shtiaq	BV:205	0 to 1	
IDF Manual Transition	R/W		s_idftrn	BV:78	0 to 1	S_IDFTRN
IDF Operation Errors?	READ ONLY		idf_bad	BV:52	0 to 1	IDFBAD
IDF Speed Override Flag	READ ONLY		sfan_hand_alarm	BV:7009	0 to 1	FAN_OVRD
IDF Speed Reduction On	READ ONLY		fanred10	BV:7	0 to 1	FANRED10
IDF VFD Com Failure	R/W		f_vfdcf	BV:254	0 to 1	
IDF VFD Earth fault	R/W		f_vfdef	BV:255	0 to 1	
IDF VFD Hand Alert	R/W		a_vfdhnd	BV:227	0 to 1	
IDF VFD Internal V Low	R/W		f_vfdivl	BV:256	0 to 1	
IDF VFD Low V Error	R/W		f_vfdlve	BV:257	0 to 1	
IDF VFD Main Power Fail	R/W		f_vfdmpf	BV:258	0 to 1	
IDF VFD Motor In Reverse	R/W		vfd1mdir	BV:102	0 to 1	VFD1MDIR
IDF VFD Motor Over Temp	R/W		f_vfdmot	BV:418	0 to 1	
IDF VFD Over Current	R/W		f_vfdov	BV:261	0 to 1	
IDF VFD Over Temperature	R/W		f_vfdot	BV:249	0 to 1	
IDF VFD Over Voltage	R/W		f_vfdoc	BV:259	0 to 1	
IDF VFD Overload	R/W		f_vfdol	BV:260	0 to 1	
IDF VFD Phase U Loss	R/W		f_vfdpul	BV:250	0 to 1	
IDF VFD Phase V Loss	R/W		f_vfdpwl	BV:252	0 to 1	
IDF VFD Phase W Loss	R/W		f_vfdpvl	BV:251	0 to 1	
IDF VFD Short Circuit	R/W		f_vfdsc	BV:262	0 to 1	
IDF VFD Undervoltage	R/W		f_vfduv	BV:263	0 to 1	
IDF VFD Unexpected Fault	R/W		f_vfdune	BV:253	0 to 1	
IDF VFD Warning Alert	R/W		a_vfdwar	BV:228	0 to 1	
IGC Fan On Request (IFO)	READ ONLY		igc_ifo	BV:13	0 to 1	IGC_IFO
Ignition Failure Alert	R/W		a_noign	BV:222	0 to 1	
In Pre-Occupancy Purge?	READ ONLY		preoccon	BV:38	0 to 1	PREOCCON
Indoor Fan Alerts	R/W		idf_alarm	BV:45	0 to 1	FAN_AL
Is IAQ Override Active?	READ ONLY		iaq_ovrd	BV:164	0 to 1	IAQ_OVRD
Linkage Active	READ ONLY		link_active	BV:58	0 to 1	LNK_ACT
Liq Diverter Val Rly Tst	R/W		s_ldv_a	BV:281	0 to 1	S_LDV_A
Liquid Diverter Val CirA	R/W		ldv_a	BV:7011	0 to 1	LDV_A
Local Sched Occ Request	R/W		loc_occ	BV:95	0 to 1	LOC_OCC
Loss of comms with SIOB	READ ONLY		a_siobl	BV:9003	0 to 1	
Low cooling locked out	READ ONLY		lc_lock	BV:317	0 to 1	LC_LOCK
Make Config Backup File	R/W		ddbckup	BV:129	0 to 1	DDBCKUP
MBB 24VDC Alert	R/W		a_mbb24d	BV:247	0 to 1	
MBB 5VDC Alert	R/W		a_mbb5dc	BV:248	0 to 1	
MBB EEPROM failure fault	R/W		f_mbbeep	BV:267	0 to 1	
MBB Fuse 2 Fault	R/W		f_mbbf2	BV:268	0 to 1	
MBB Fuse 3 Fault	R/W		f_mbbf3	BV:269	0 to 1	
MBB low voltage Fault	R/W		f_mbblov	BV:270	0 to 1	
MBB Ref Volt Fail Fault	R/W		f_mbbref	BV:271	0 to 1	
MBB RNET Voltage Alert	R/W		a_mbb12d	BV:246	0 to 1	
MBB zero crossing alert	R/W		a_mbb0x	BV:245	0 to 1	
Mechanical Cool active?	READ ONLY		mechcool	BV:301	0 to 1	MECHCOOL
Medium Cooling lockout	READ ONLY		mc_lock	BV:318	0 to 1	MC_LOCK
OACFM Alarm Relay	R/W		oacfm_rel_alarm	BV:371	0 to 1	OACFM_AL
OACFM Open Circuit Alert	R/W		a_opnoac	BV:276	0 to 1	
OACFM ShortCircuit Alert	R/W		a_shtoac	BV:277	0 to 1	
OAQ Open Circuit Alert	R/W		a_opnoaq	BV:195	0 to 1	
OAQ Short Circuit Alert	R/W		a_shtoaq	BV:206	0 to 1	
OARH Open Circuit Alert	R/W		a_opnorh	BV:197	0 to 1	
OARH Sensor Error	R/W		oarh_err	BV:60	0 to 1	OARH_ERR
OARH Short Circuit Alert	R/W		a_shtorh	BV:208	0 to 1	
OAT Open Circuit Alert	R/W		a_opnoat	BV:196	0 to 1	
OAT out of Range Alert	R/W		a_badoat	BV:186	0 to 1	
OAT Sensor Error	R/W		oat_error	BV:314	0 to 1	OAT_ERR
OAT Short Circuit Alert	R/W		a_shtoat	BV:207	0 to 1	
OAT Thermistor Alerts	R/W		oat_rel_alarm	BV:61	0 to 1	OATRL_AL
ODF Manual Transition	R/W		s_odftrn	BV:81	0 to 1	S_ODFTRN

APPENDIX E — BACNET POINTS LIST

Table Z — BACnet* BV Points List (cont)

POINT DESCRIPTION	POINT ACCESS	UNITS	BACNET OBJECT NAME	BACNET ID	VALUE RANGE	CCN POINT EQUIVALENT
Ok to fan based dehum	READ ONLY		oktofbd	BV:420	0 to 1	OKTOFBD
Ok to Dehumidify?	READ ONLY		oktodhum	BV:422	0 to 1	OKTODHUM
Ok to Preoccupancy Purge	READ ONLY		okpreocc	BV:35	0 to 1	OKPREOCC
OK to Run Heat	READ ONLY		oktoheat	BV:36	0 to 1	OKTOHEAT
OK to SupplyAirTempering	READ ONLY		oktotemp	BV:415	0 to 1	OKTOTEMP
Ok to Unocc Free Cool?	READ ONLY		oktoufc	BV:37	0 to 1	OKTOUFC
Ok to use compressors?	READ ONLY		okmechcl	BV:302	0 to 1	OKMECHCL
OK to Use Free Cooling?	READ ONLY		ok_free_cl	BV:65	0 to 1	OKFREECL
Ok to use humidimizer	READ ONLY		oktohumz	BV:421	0 to 1	OKTOHUMZ
Percent Enable/Disable	R/W		perc_bac	BV:303	0 to 1	PERC_BAC
Power Exhaust 1 Relay	R/W		pe1	BV:15	0 to 1	PE1
Power Exhaust 1 Test	R/W		s_pe_1	BV:82	0 to 1	S_PE_1
Power Exhaust 2 Relay	R/W		pe2	BV:66	0 to 1	PE2
Power Exhaust 2 Test	R/W		s_pe_2	BV:83	0 to 1	S_PE_2
RARH Open Circuit Alert	R/W		a_opnrhh	BV:199	0 to 1	
RARH Sensor Error	R/W		rarh_err	BV:67	0 to 1	RARH_ERR
RARH Short Circuit Alert	R/W		a_shtrrh	BV:210	0 to 1	
RAT Open Circuit Alert	R/W		a_opnrat	BV:198	0 to 1	
RAT out of Range Alert	R/W		a_badrat	BV:187	0 to 1	
RAT out of Range Alert	R/W		a_badsat	BV:188	0 to 1	
RAT Sensor Error	R/W		rat_err	BV:68	0 to 1	RAT_ERR
RAT Short Circuit Alert	R/W		a_shtrat	BV:209	0 to 1	
Refrig Circuit Alerts	R/W		circuit_alarm	BV:313	0 to 1	CKT_AL
Reheat Dischg Valve CirA	R/W		rdv_a	BV:7012	0 to 1	RDV_A
Reheat Liq Valv Rly Test	R/W		s_rlv_a	BV:455	0 to 1	S_RLV_A
Reheat Liquid Valve CirA	R/W		rlv_a	BV:7051	0 to 1	RLV_A
Remote Occupancy Switch	R/W		remocc	BV:29	0 to 1	REMOCC
Remote shutdown fault	R/W		f_remoft	BV:272	0 to 1	
Remote Shutdown Switch	R/W		rem_shut	BV:9001	0 to 1	REMSHUT
Reset All Current Alarms	R/W		alarm_reset	BV:33	0 to 1	ALRESET
Reset Filter Timer	R/W		reset_filter_timer	BV:109	0 to 1	RESETFLT
RH sensor failure Alert	R/W		rhs_al	BV:308	0 to 1	RHS_AL
Rht Dischg Valve Rly Tst	R/W		s_rdv_a	BV:282	0 to 1	S_RDV_A
Rollout without Heating	R/W		f_ronoht	BV:235	0 to 1	
RUN AUTO COOLING TEST	R/W		autocool	BV:160	0 to 1	AUTOCOOL
RUN AUTO HEATING TEST	R/W		autoheat	BV:161	0 to 1	AUTOHEAT
RUN AUTO SYSTEM TEST	R/W		autosys	BV:162	0 to 1	AUTOSYS
Run away heat fault	R/W		f_hstuck	BV:266	0 to 1	
SAT Sensor Error	R/W		sat_err	BV:84	0 to 1	SAT_ERR
SAT/RAT Sensor Alerts	R/W		sa_ra_alarm	BV:311	0 to 1	SATRATAL
SDPA Sensor Error	R/W		sdpa_err	BV:63	0 to 1	SDPA_ERR
Shut Down on IDF Failure	R/W		sfan_fail_alarm	BV:7008	0 to 1	FATALFAN
Shutdown A1 First	R/W		sdwn_a1	BV:449	0 to 1	SDWN_A1
Shutdown A2 First	R/W		sdwn_a2	BV:450	0 to 1	SDWN_A2
Shutdown Loader First	R/W		sdwn_ald	BV:451	0 to 1	SDWN_ALD
Smoke Purge Input	R/W		purge	BV:80	0 to 1	PURGE
Space Sensors Alerts	R/W		space_alarm	BV:103	0 to 1	SPACE_AL
SPRH Open Circuit Alert	R/W		a_opnsrh	BV:274	0 to 1	
SPRH Short Circuit Alert	R/W		a_shtsrh	BV:275	0 to 1	
SPT Open Circuit Alert	R/W		a_opnspt	BV:201	0 to 1	
SPT Sensor Error	R/W		space_err	BV:7001	0 to 1	SPT_ERR
SPT Short Circuit Alert	R/W		a_shtspt	BV:212	0 to 1	
SPTO Sensor Error	R/W		stpt_err	BV:7002	0 to 1	SPTO_ERR
SPToutofRangeAlert	R/W		a_badspt	BV:190	0 to 1	
SSPA Sensor Error	R/W		sspa_err	BV:89	0 to 1	SSPA_ERR
Start Config Restore	READ ONLY		ddrstre	BV:130	0 to 1	DDRSTRE
Supply Air Temper Enable	R/W		sup_air_temp_en	BV:410	0 to 1	SATEMPEN
System Demand Alarm	R/W		sys_dmd_alarm	BV:26	0 to 1	SYSDMDAL
Temp Compensate Start On	READ ONLY		tcs_Act	BV:133	0 to 1	TCS_ACT
Thermostat Alerts	R/W		tstat_al	BV:104	0 to 1	TSTAT_AL
Thermostat G Input	R/W		g_input	BV:1021	0 to 1	G

APPENDIX E — BACNET POINTS LIST

Table Z — BACnet* BV Points List (cont)

POINT DESCRIPTION	POINT ACCESS	UNITS	BACNET OBJECT NAME	BACNET ID	VALUE RANGE	CCN POINT EQUIVALENT
Thermostat W1 Input	R/W		w1_input	BV:1017	0 to 1	W1
Thermostat W2 Input	R/W		w2_input	BV:1018	0 to 1	W2
Thermostat Y1 Input	R/W		y1_input	BV:1019	0 to 1	Y1
Thermostat Y2 Input	R/W		y2_input	BV:1020	0 to 1	Y2
Thermostat Y3 Input	R/W		y3_input	BV:28	0 to 1	Y3
TIME range alert	R/W		a_notime	BV:237	0 to 1	
Today Is A Holiday	READ ONLY		holtoday	BV:98	0 to 1	HOLTODAY
Tomorrow Is A Holiday	READ ONLY		hol_tmrw	BV:96	0 to 1	HOL_TMRW
Transducer Sensor Alerts	R/W		trans_al	BV:310	0 to 1	TRANS_AL
Tstat Adaptive Staging	R/W		adptstat	BV:115	0 to 1	ADPTSTAT
TSTAT Cool alert	R/W		a_impcl	BV:220	0 to 1	
TSTAT Heat alert	R/W		a_impht	BV:221	0 to 1	
TSTAT Heat Cool alert	R/W		a_simhc	BV:223	0 to 1	
Unocc Free Cool Active	READ ONLY		ufc_act	BV:135	0 to 1	UFC_ACT
USB Find Restore File	R/W		backfile	BV:111	0 to 1	BACKFILE
User Password Protection	R/W		pass_ebl	BV:100	0 to 1	PASS_EBL
VFD Alerts	R/W		vfd_alarm	BV:315	0 to 1	VFD_AL
VFD Config OK?	READ ONLY		vfdcfgok	BV:105	0 to 1	VFDCFGOK
VFD Curlim Warning Alert	R/W		a_vfdcwa	BV:238	0 to 1	
VFD Hand Mode Shutdown?	R/W		handshut	BV:8	0 to 1	HANDSHUT
VFD Reverse Select	R/W		rev_sel	BV:69	0 to 3	REVSEL
VFD Thermal Warning alert	R/W		a_vfdtwa	BV:239	0 to 1	
VFD Voltage Warning alert	R/W		a_vfdvwa	BV:240	0 to 1	

* BACnet is a registered trademark of ASHRAE (American Society of Heating, Refrigerating, and Air-Conditioning Engineers).

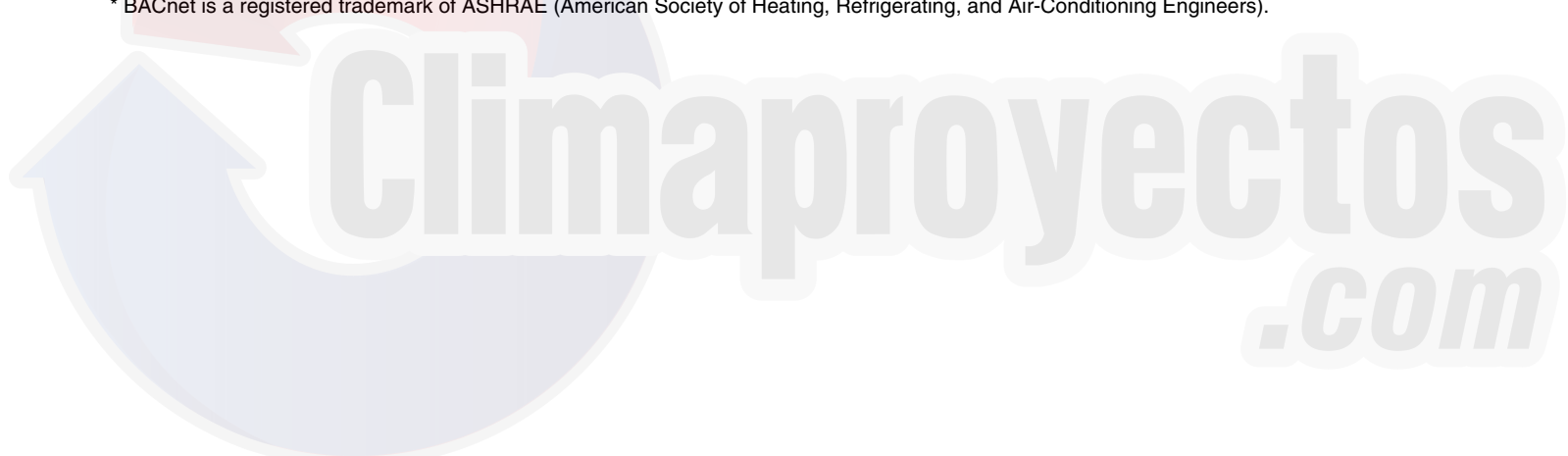

APPENDIX E — BACNET POINTS LIST

Table AA — BACnet* MSV Points List

POINT DESCRIPTION	POINT ACCESS	UNITS	BACNET OBJECT NAME	BACNET ID	VALUE RANGE	CCN POINT EQUIVALENT
Active Occupancy control	READ ONLY		occ_ctrl	MSV:14	0 to 6	OCC_CTRL
Alert from thermostat	READ ONLY		tstat_alert	MSV:8	0 to 65535	THM_ALT
Analog Input IAQ Control	R/W		iaqancfg	MSV:25	0 to 3	IAQANCFG
Backup and Restore	READ ONLY		bac_rest	MSV:44	0 to 2	
BACnet BMS baud rate	READ ONLY		bac_baud	MSV:18	0 to 5	BAC_BAUD
BAS Protocol Select	R/W		bms_cfg	MSV:11	0 to 2	BMS_CFG
BMS Occupancy Request	R/W		bms_occ	MSV:12	0 to 2	BMS_OCC
Communications status	R/W		e0commst	MSV:17	0 to 1	E0COMMST
Comp. Framework	R/W		sysvtype	MSV:2003	0 to 2	SYSVTYPE
Cool demand Limit Level	R/W		cdlm_level	MSV:56	0 to 3	CDMDLLEV
Fan Based Dehum Type	R/W		fbd_type	MSV:58	0 to 2	FBD_TYPE
Filter Status Sw Channel	R/W		filter_channel	MSV:41	0 to 5	FILTCHAN
Filter Status Switch Type	R/W		filt_cfg	MSV:42	0 to 2	FILT_CFG
Firmware Release State	READ ONLY		fw_state	MSV:19	0 to 2	FW_STATE
Heat demand Limit Level	R/W		hdlm_level	MSV:57	0 to 3	HDMDLLEV
IAQ override sw channel	R/W		iaqo_sw_chan	MSV:444	0 to 5	IAQOCHAN
IDF VFD Fault Detail	READ ONLY		svdfdit	MSV:23	0 to 17	SVDFFLT
IDF VFD Nom Motor HP Num	READ ONLY		motpwr	MSV:22	0 to 500	MOTPWR
IDF VFD RFI Filter	R/W		rfi_filter	MSV:4	0 to 1	RFIFILTR
IDF VFD Switch Frequency	R/W		switch_freq	MSV:7	0 to 10	SWTFREQ
IDF VFD Warning Detail	READ ONLY		vfd_warning	MSV:3001	0 to 5	SVFDWAR
Indoor Fan Type Cfg	R/W		idftype	MSV:450	0 to 2	IDFTYPE
Keep configuration	R/W		keepconf	MSV:47	0 to 2	KEEPCONF
Linkage Occupied Request	R/W		lnk_occ	MSV:13	0 to 2	LNK_OCC
Operation Status Color	READ ONLY		color	MSV:9	0 to 15	COLOR
Remote Occupancy Channel	R/W		rmocchan	MSV:46	0 to 5	RMOCCHAN
Remote Occupancy Sw Type	R/W		rmoc_cfg	MSV:45	0 to 1	RMOC_CFG
Running Mode Operation	READ ONLY		sub_mode	MSV:43	0 to 2	SUB_MODE
System Demand	READ ONLY		sys_demand_enum	MSV:101	0 to 255	SYS_DMDE
System Mode	READ ONLY		sys_mode	MSV:2002	0 to 2	SYSMODE
Test Inactivity Time Out	R/W		test_ito	MSV:156	0 to 2	TEST_ITO
Thermostat Hardware Type	R/W		tstat_type	MSV:5	0 to 3	STATTYPE
Type of Heat Installed	R/W		ht_type	MSV:16	0 to 2	HEATTYPE
Unit Control Type	R/W		control_type	MSV:2	0 to 2	CTRLTYPE
Ventilation Status	READ ONLY		ventstat	MSV:6	0 to 9	VENTSTAT
When to Unocc Free Cool?	R/W		ufc_cfg	MSV:24	0 to 2	UFC_CFG

* BACnet is a registered trademark of ASHRAE (American Society of Heating, Refrigerating, and Air-Conditioning Engineers).

APPENDIX E — BACNET POINTS LIST

Table AB — BACnet* String Points List

POINT DESCRIPTION	POINT ACCESS	UNITS	BACNET OBJECT NAME	BACNET ID	VALUE RANGE	CCN POINT EQUIVALENT
Application SW Version	READ ONLY		fw_cesr	String:0	a to z, A to Z, 0 to 9 and -	FW_CESR
BACnet Firmware Version	R/W		bac_fwv	String:0	a to z, A to Z, 0 to 9 and -	BAC_FWV
Base Board serial number	READ ONLY		bd_ser	String:0	a to z, A to Z, 0 to 9 and -	BD_SER
Bootloader SW Version	READ ONLY		bl_cesr	String:0	a to z, A to Z, 0 to 9 and -	BL_CESR
Device Description	READ ONLY		dev_desc	String:0	a to z, A to Z, 0 to 9 and -	DEV_DESC
Device Location	READ ONLY		dev_loc	String:0	a to z, A to Z, 0 to 9 and -	DEV_LOC
Equipment Model number	READ ONLY		eq_mod	String:0	a to z, A to Z, 0 to 9 and -	EQ_MOD
Equipment Serial number	READ ONLY		eq_ser	String:0	a to z, A to Z, 0 to 9 and -	EQ_SER
MBB Part Number	READ ONLY		bd_cepl	String:0	a to z, A to Z, 0 to 9 and -	BD_CEPL
MBB Program Part Number	READ ONLY		bd_cepp	String:0	a to z, A to Z, 0 to 9 and -	BD_CEPP
ProgramLocationProperty	R/W		progloc	String:0	a to z, A to Z, 0 to 9 and -	PROGLOC
ProgramObject Name	R/W		progname	String:0	a to z, A to Z, 0 to 9 and -	PROGNAME
Reference Number	READ ONLY		ref_num	String:0	a to z, A to Z, 0 to 9 and -	REF_NUM
Ventilation Status	READ ONLY		venttext	String:0	a to z, A to Z, 0 to 9 and -	VENTTEXT

* BACnet is a registered trademark of ASHRAE (American Society of Heating, Refrigerating, and Air-Conditioning Engineers).

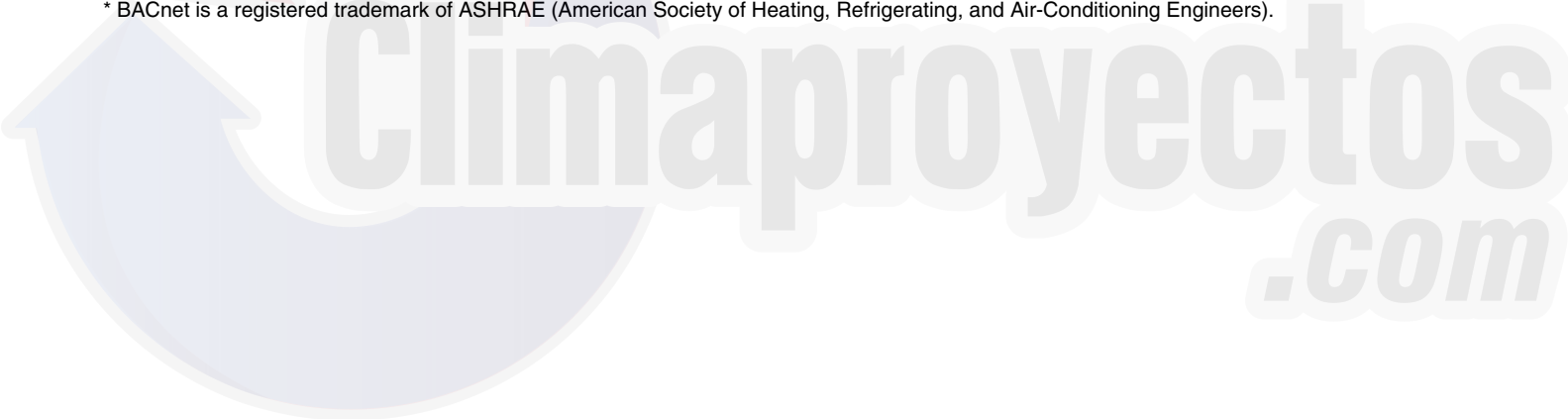

CONTROL SET POINT AND CONFIGURATION LOG

MODEL NO. _____

SOFTWARE VERSIONS:

SERIAL NO. _____

MBB:CESR131651-_____

DATE _____

VFD FW VERSION-_____

TECHNICIAN _____

INDICATE UNIT SETTINGS BELOW

CONTROL TYPE: Thermostat/T55 Space Temp./T-56 Space Temp./T-59 Space Temp.

SETPOINT Cooling Occupied: _____ Unoccupied: _____
 Heating Occupied: _____ Unoccupied: _____

Table AC — Settings Main Menu Layout

DISPLAY TEXT	EXPANDED TEXT	RANGE	UNITS	DEFAULT	POINT	ENTRY
SETTINGS	Settings Menu					
SPACE SET POINTS	Space Setpoints Adjustment Menu					
OCC COOL SETPOINT	Occupied Cool Setpoint	55 to 80	°F	78	OCSP	
OCC HEAT SETPOINT	Occupied Heat Setpoint	55 to 80	°F	68	OHSP	
UNOCC COOL SETPNT	Unoccupied Cool Setpoint	65 to 95	°F	85	UCSP	
UNOCC HEAT SETPNT	Unoccupied Heat Setpoint	40 to 80	°F	60	UHSP	
HEAT-COOL SP GAP	Heat-Cool Setpoint Gap	2 to 10	^F	5	HCSP_GAP	
SPT SLIDER RANGE	SPT Offset Range (±)	0 to 5.0	°F	5	SPTO_RNG	
OCC SPRH SET PT	Occupied SPRH Setpoint	0 to 100	%	55	SPRH_OSP	
UNOCC SPRH SET PT	Unoccupied SPRH Setpoint	0 to 100	%	55	SPRH_USP	
SA TEMPER SET PNT	SA Tempering Setpoint	xx	°F	50	SATEMPSP	
TEMP DEMAND CONFIG	Temperature Demand Configuration Menu					
LOW COOL DMD ON	Low Cool Demand On	-1 to 2.0	°F	0.5	DMDLCON	
MED COOL DMD ON	Medium Cool Demand On	0.5 to 20.0	°F	1	DMDMCON	
HIGH COOL DMD ON	High Cool Demand On	0.5 to 20.0	°F	2	DMDHCON	
LOW COOL DMD OFF	Low Cool Demand Off	-1 to 2.0	°F	-0.5	DMDLCOFF	
COOL DMD LEVEL UP	Cool Demand Level Up	-2 to 2.0	^F/min	-0.2	CDMD_LUP	
LOW HEAT DMD ON	Low Heat Demand On	-1 to 2.0	°F	0.5	DMDLHON	
HIGH HEAT DMD ON	High Heat Demand On	0.5 to 20.0	°F	2	DMDHHON	
LOW HEAT DMD OFF	Low Heat Demand Off	-1 to 2.0	°F	-0.5	DMDLHOFF	
HEAT DMD LEVEL UP	Heat Demand Level Up	-2 to 2.0	^F/min	-0.2	HDMD_LUP	
DEMAND TIMEGUARD1	Space Demand Time Guard1	60 to 600	sec	180	TDMD_TG1	
DEMAND TIMEGUARD2	Space Demand Time Guard2	0 to 600	sec	300	TDMD_TG2	
DEMAND TIMEGUARD3	Space Demand Time Guard3	5 to 120	min	10	TDMD_TG3	
DMD LIMIT CONFIG	DEMAND LIMIT CONFIG					
COOL DMD LIM LEV1	Cool DMD Offset level 1	0 to 99	°F	1	CLDOLEV1	
COOL DMD LIM LEV2	Cool DMD Offset level 2	0 to 99	°F	3	CLDOLEV2	
COOL DMD LIM LEV3	Cool DMD Offset level 3	0 to 99	°F	5	CLDOLEV3	
HEAT DMD LIM LEV1	Heat DMD Offset level 1	0 to 99	°F	1	HTDOLEV1	
HEAT DMD LIM LEV2	Heat DMD Offset level 2	0 to 99	°F	3	HTDOLEV2	
HEAT DMD LIM LEV3	Heat DMD Offset level 3	0 to 99	°F	5	HTDOLEV3	
CLOCK	Clock Adjustment Menu					
TIME	Clock Hour and Minute	xx:xx	hh.mm		TIME	
DATE	Current Date	MM/DD/YYYY			DATE	
DAYLIGHT SAVINGS	Daylight Savings Configuration Menu				DST Menu	
DAYLIGHT SAVINGS?	DST allowed?	Enable/Disable		Enable	DST_CFG	

CONTROL SET POINT AND CONFIGURATION LOG

Table AC — Settings Main Menu Layout (cont)

DISPLAY TEXT	EXPANDED TEXT	RANGE	UNITS	DEFAULT	POINT	ENTRY
<i>CLOCK (cont)</i>						
DST START MONTH	DST Start Month	1=JANUARY, 2=FEBRUARY, 3=MARCH, 4=APRIL, 5=MAY, 6=JUNE, 7=JULY, 8=AUGUST, 9=SEPTEMBER, 10=OCTOBER, 11=NOVEBER, 12=DECEMBER		3=MARCH	STARTM	
DST START WEEK	DST Start Week	1 to 5		2	STARTW	
DST START DAY	DST Start Day	1=MONDAY, 2=TUESDAY, 3=WEDNESDAY, 4=THURSDAY, 5=FRIDAY, 6=SATURDAY, 7=SUNDAY		7=SUNDAY	STARTD	
DST MINS TO ADD	DST Minutes to Add	0 to 90	min	60	MINADD	
DST STOP MONTH	DST Stop Month	1=JANUARY, 2=FEBRUARY, 3=MARCH, 4=APRIL, 5=MAY, 6=JUNE, 7=JULY, 8=AUGUST, 9=SEPTEMBER, 10=OCTOBER, 11=NOVEBER, 12=DECEMBER		1=JANUARY	STOPM	
DST STOP WEEK	DST Stop Week	1 to 5		1	STOPW	
DST STOP DAY	DST Stop Day	1=MONDAY, 2=TUESDAY, 3=WEDNESDAY, 4=THURSDAY, 5=FRIDAY, 6=SATURDAY, 7=SUNDAY		7=SUNDAY	STOPD	
DST MINS TO SUB	DST Minutes to Subtract	0 to 90	min	60	MINSUB	
START TIME IN DAY	Time in day to start DST	0 to 600	min	120	DST_TOD	
SCHEDULES						
Schedules Adjustment Menu						
SCHEDULE NUMBER	CCN Schedule Number	0 = Always Occupied, 1-64 = Local Schedule, 65-99 = Global Schedule		0=Always Occupied	SCHEDNUM	
OCCUPANCY SCHEDULE	OCCUPANCY SCHEDULE DATA					
HOLIDAYS	Holiday Adjustment Menu					
ALLOW G. HOLIDAY?	Accept Global Holidays?	Yes/No		No	HOLIDAYT	
TIMED OVR LENGTH	Timed Override Duration	0 to 4	hours	4	OTL_CFG	
UNIT CONFIGURATIONS						
Unit Configurations Menu						
General Unit Configurations Menu						
STARTUP DELAY	Unit Startup Delay	10 to 600	sec	30	STARTDLY	
UNIT CONTROL TYPE	Unit Control Type	0=TSTAT, 1=SPACE SEN, 2=RAT SEN		0=TSTAT	CTRLTYPE	
THERMOSTAT TYPE	Thermostat Hardware Type	0=CONV 2C2H, 1=DIGI 2C2H, 2=CONV 3C2H, 3=DIGI 3C2H, 4=DIGI 2C2H_S		2=CONV 3C2H	STATTYPE	
ADAPTIVE TSTAT	Tstat Adaptive Staging	Yes/No		Yes	ADPTSTAT	
DIRTY FILTER TIME	Change Filter Timer	0 to 9999	hours	600	FILTIFE	

CONTROL SET POINT AND CONFIGURATION LOG

Table AC — Settings Main Menu Layout (cont)

DISPLAY TEXT	EXPANDED TEXT	RANGE	UNITS	DEFAULT	POINT	ENTRY
<i>UNIT CONFIGURATIONS (cont)</i>						
TEST MODE TIMEOUT	Test inactivity time out	0=Disabled, 1=30 minutes, 2=1 hour, 3=2 hours, 4=4 hours, 5=8 hours, 6=12 hours		4=4 hours	TEST_ITO	
CCH MAX TEMP	CCH Max Temperature	40 to 90	°F	65	CCHMAXT	
STD BARO PRESSURE	Std Barometric Pressure	13.00 to 35.00	in. Hg	29.92	STD_BARP	
LINK STAGEUP TIME	Linkage Stage inc. time	60 to 600	sec	180	LSTAGINC	
UNIT'S MAX SAT	Unit's Maximum SAT	130 to 210	°F	200	UMAX_SAT	
AUTO SAT FAULTS?	Auto Clr SAT Limit Fault	Yes/No		No	SATLACLR	
ADAPTIVE TCS?	Adaptive Temp Comp Start	Enable/Disable		Enable	TCS_CFG	
USER TCS BIASTIME	User TCS Start bias time	0 to 180	min	0	TCSUBIAS	
SWITCH INPUTS CONFIGS	DI Config Menu					
FIRE SHUTDOWN SW	Fire Shutdown Switch	0=NORM OPEN, 1=NORM CLSD, 2=NO SWITCH		2: no FIOP 0: FIOP	FIRE_CFG	
HUMSTAT CHANNEL	Humidistat Status Channel	0=None, 1=MBB DI12, 2=MBB DI13, 3=MBB DI14, 4=MBB DI02, 5=MBB DI04, 6=SIOB DI01		0=for all except Humidimizer 6=Humidimizer Units	HUMDCHAN	
HUMSTAT SW TYPE	Humidistat Switch Type	0=NORM OPEN, 1=NORM CLSD		0=NORM OPEN	HUMD_CFG	
FILTER SW CHANNEL	Filter Status Sw Channel	0=None, 1=MBB DI12, 2=MBB DI13, 3=MBB DI14, 4=MBB DI02, 5=MBB DI04		0=None	FILTCHAN	
FILTER SW TYPE	Filter Status Switch Type	0=NORM OPEN, 1=NORM CLSD		0=NORM OPEN	FILT_CFG	
REMOTE OCC CHAN	Remote Occupancy Channel	0=None, 1=MBB DI12, 2=MBB DI13, 3=MBB DI14, 4=MBB DI02, 5=MBB DI04		0=None	RMOCCHAN	
REMOTE OCC TYPE	Remote Occupancy Sw Type	0=NORM OPEN, 1=NORM CLSD		0=NORM OPEN	RMOC_CFG	
REM.SHUTDOWN CHAN	Remote Shutdown Channel	0=None, 1=MBB DI12, 2=MBB DI13, 3=MBB DI14, 4=MBB DI02, 5=MBB DI04		0=None	ROFFCHAN	
REM.SHUTDOWN SW T	Remote Shutdown Sw Type	0=NORM OPEN, 1=NORM CLSD		0=NORM OPEN	ROFF_CFG	
REM.SHUTDOWN TYPE	Remote Shutdown ALM Type	0=Normal, 1=Emergency		0=Normal	ROFFTYPE	
COFS CHANNEL	COFS Assigned Channel	0=None, 1=MBB DI12, 2=MBB DI13, 3=MBB DI14, 4=MBB DI02, 5=MBB DI04		0=None (no FIOP) 4=MBB DI02 (FIOP)	COFSCHAN	
COFS TYPE	COFS Switch Type	0=NORM OPEN, 1=NORM CLSD		1=NORM CLSD	COFS_CFG	
GEN STATUS CHAN	General Status Channel	0=None, 1=MBB DI12, 2=MBB DI13, 3=MBB DI14, 4=MBB DI02, 5=MBB DI04		0=None	GEN_CHAN	
GEN STAT SW TYPE	General Status Sw Type	0=NORM OPEN, 1=NORM CLSD		0=NORM OPEN	GENS_CFG	
SHUTDOWN GEN STAT	General Status shutdown?	Yes/No		Yes	GENFATAL	

CONTROL SET POINT AND CONFIGURATION LOG

Table AC — Settings Main Menu Layout (cont)

DISPLAY TEXT	EXPANDED TEXT	RANGE	UNITS	DEFAULT	POINT	ENTRY
<i>UNIT CONFIGURATIONS (cont)</i>						
ENTHALPY SW CHAN	Enthalpy Sw Channel	0=None, 1=MBB DI12, 2=MBB DI13, 3=MBB DI14, 4=MBB DI02, 5=MBB DI04		0=None	ENTHCHAN	
ENTHALPY SW TYPE	Enthalpy Switch Type	0=NORM OPEN, 1=NORM CLSD		0=NORM OPEN	ENTH_CFG	
IAQ OVERRIDE SW CH	IAQ override sw channel	0=None, 1=MBB DI12, 2=MBB DI13, 3=MBB DI14, 4=MBB DI02, 5=MBB DI04, 6=SIOB DI01			IAQOCHAN	
IAQ OVRRD SW TYPE	IAQ Override Switch Type	0=NORM OPEN, 1=NORM CLSD			IAQOSCFG	
ANALOG INPUT CONFIGS						
Analog Inputs Configuration Menu						
SPRH SENS CHANNEL	SPRH Assigned Channel	0=None, 1=MBB AI06, 2=MBB AI07, 3=MBB AI08 4=SIOB AI10		0=None	SPRHCHAN	
SPRH RH @ 4MA	SPRH Sensor Value at 4mA	0 to 100	%	0	SPRH_4MA	
SPRH RH @ 20MA	SPRH Sensor Value at 20mA	0 to 100	%	1	SPRH20MA	
IAQ SENSOR CHAN	IAQ Assigned Channel	0=None, 1=MBB AI06, 2=MBB AI07, 3=MBB AI08		0: no FIOF 1: FIOF	IAQ_CHAN	
IAQ PPM@ 4MA	IAQ Sensor Value at 4mA	0 to 5000	ppm	0	IAQ_4MA	
IAQ PPM@ 20MA	IAQ Sensor Value at 20mA	0 to 5000	ppm	2000	IAQ_20MA	
OAQ SENSOR CHAN	OAQ Assigned Channel	0=None, 1=MBB AI06, 2=MBB AI07, 3=MBB AI08		0=None	OAQ_CHAN	
OAQ PPM@ 4MA	OAQ Sensor Value at 4mA	0 to 5000	ppm	0	OAQ_4MA	
OAQ PPM@ 20MA	OAQ Sensor Value at 20mA	0 to 5000	ppm	2000	OAQ_20MA	
OARH SENSOR CHAN	OARH Assigned Channel	0=None, 1=MBB AI06, 2=MBB AI07, 3=MBB AI08		0: no Enthalpy FIOF 3: Enthalpy FIOF	OARHCHAN	
OARH RH @ 4MA	OARH Sensor Value at 4mA	0 to 100	%	0	OARH_4MA	
OARH RH @ 20MA	OARH Sensor Val. at 20mA	0 to 100	%	100	OARH20MA	
RARH SENS CHANNEL	RARH Assigned Channel	0=None, 1=MBB AI06, 2=MBB AI07, 3=MBB AI08		0=None	RARHCHAN	
RARH RH @ 4MA	RARH Sensor Value at 4mA	0 to 100	%	0	RARH_4MA	
RARH RH @ 20MA	RARH Sensor Value at 20mA	0 to 100	%	100	RARH20MA	
OACFM SENSOR CHAN	OACFM Assigned Channel	0=None, 1=MBB AI06, 2=MBB AI07, 3=MBB AI08, 4=SIOB AI10		0=None	OACFMCHAN	
OACFM@ 4MA	OACFM value at 4mA	0 to 100	CFM	0	OACFM_4MA	
OACFM@ 20MA	OACFM Value at 20mA	0 to 100	CFM	20	OACFM20MA	
COOLING						
Cooling Configurations Menu						
LOW COOL COMP	Low Cool Compressor	1 to 2		1	LC_COMP	
COMP MIN ON TIME	Compressor Min On Time	180 to 600	sec	300	C_MINON	
COMP MIN OFF TIME	Compressor Min Off Time	120 to 600	sec	180	C_MINOFF	
STRIKE CLEAR TIME	Runtime to Reset Strikes	120 to 999	sec	300	MIN_ON_S	
COOL STAGEUP TIME	Cool Stage Increase Time	120 to 999	sec	450	CSTAGINC	
COOL SATTREND LEV	Cooling SAT Trend Level	-1.0 to 1.0		-0.2	SAT_TLC	
UPPER MIN SAT	Cool Min SAT Upper Level	35.0 to 65.0	°F	53 (sizes 07-12) 56 (sizes 04-06, 14-26)	SATMIN_H	
LOWER MIN SAT	Cool Min SAT Lower Level	35.0 to 65.0	°F	42 (sizes 07-12) 46 (sizes 04-06, 14-26)	SATMIN_L	
SPRH DEADBAND	Space RH Deadband	0	%	5	SPRH_DB	

CONTROL SET POINT AND CONFIGURATION LOG

Table AC — Settings Main Menu Layout (cont)

DISPLAY TEXT	EXPANDED TEXT	RANGE	UNITS	DEFAULT	POINT	ENTRY
<i>COOLING (cont)</i>						
HUMZ LOCKOUT OAT	Humidimizer Lockout Temp	-20 to 75	°F	40	OATLHUMZ	
HUMZ ENABLE	Humidimizer Equipped	Yes/No		No: no Humidizer FIOF Yes: Humidizer FIOF	HUMZ_EN	
COOL FANOFF DELAY	Cooling Fan-off Delay	0 to 600	sec	75	COOL_FOD	
FBD CONTROL TYPE	Fan Based Dehum Type	0=NONE, 1=Comfort, 2=Max		0=NONE	FBD_TYPE	
FBD LOW SP	FBDH Low Set Point	-20 to 0	°F delta	-2.5	FBDLO_SP	
FBD SST SETPOINT	FBDH Max Mode SST SP	20 to 60	°F	38	FBDSSSTSP	
FBD SST MIN VALUE	FBDH Min SST Threshold	10 to 60	°F	32	FBDH_SST	
FBD COMFORT SAT	FBDH Comfort SAT SP	35 to 80	°F	46	FBDH_SAT	
FBDSAT COMF DELTA	FBD Comfort SAT Delta	0 to 40	°F	11	FBDSATDT	
FBD MIN IDF SPEED	Minimum IDF Speed	0 to 100	%	25	FBDMINSP	
FBD MAX IDF SPEED	FBD Fan Max	0 to 100	%	100	FBDFMX	
LOW AMBIENT	LOW AMBIENT CONFIGS MENU					
CIR.A LOCKOUT OAT	Circuit A Lockout Temp	-20 to 75	°F	0: no Economizer FIOF 40: Economizer FIOF	OATLCMPA	
LOW AMBIENT TEMP	Low Ambient Temperature	0 to 80	°F	66	LA_TEMP	
LOW COOL MIN OAT	Low Cool lockout Temp	-20 to 60	°F	10 (sizes 04-06) 30 (sizes 07-12) 40 (sizes 14-26)	LCLOCKSP	
MED COOL MIN OAT	Medium Cool lockout Temp	-20 to 60	°F	20 (sizes 04-12) 30 (sizes 14-26)	MCLOCKSP	
LA DEHUM LEV 1	Low Ambient Dehum Lev 1	40 to 125	°F	80	LAHTEMP1	
LA DEHUM LEV 2	Low Ambient Dehum Lev 2	40 to 125	°F	61	LAHTEMP2	
LA DEHUM LEV 3	Low Ambient Dehum Lev 3	40 to 125	°F	55	LAHTEMP3	
LA DEHUM SDT SP 1	LA Dehum SDT SP Lev 1	60 to 120	°F	93	LHSDTSP1	
LA DEHUM SDT SP 2	LA Dehum SDT SP Lev 2	60 to 120	°F	93	LHSDTSP2	
LA DEHUM SDT SP 3	LA Dehum SDT SP Lev 3	60 to 120	°F	104	LHSDTSP3	
CHARGE DIAGNOSTICS	Refrigerant Charge Diagnostic Config Menu					
LOW CHARGE LEVEL	Low Refrig Charge Level	0 to 150	psi	50	LOCHARGE	
NO LOW CHARGE OAT	Low Charge Disable Temp	-40 to 50	°F	10	LOCH_LOT	
CIR.A SDP LIMIT	CirA High Pressure Limit	400 to 700	psi	600	HIPLIM_A	
LOW DISCHARGE LEV	Low Discharge Level	0 to 20	°F	0	SDTLEV	
MIN PRESS RATIO	Minimum Pressure Ratio	0 to 5		1.35	MINPSI_R	
LOW SUCTION DIAG.	Low Suction Diagnostic Config Menu					
LOW SUC OK TEMP	Suction OK Temperature	10 to 50	°F	18	SSTOK	
LOW SUC LEVEL 1	Low Suction Level 1 Temp	10 to 50	°F	20	SSTLEV1	
LOW SUC LEVEL 2	Low Suction Level 2 Temp	5 to 50	°F	15	SSTLEV2	
LOW SUC LEVEL 3	Low Suction Level 3 Temp	0 to 50	°F	10	SSTLEV3	
LO SUC DIAG DELAY	Delay On Low SST Check	0 to 300	sec	0	SSTCKDLY	
COMPRESSOR TRANSITION	Compressor Transition diagnostic config menu					
COMP L2 DIAG DLY	Comp level 2 Diag Delay	1 to 99	sec	15 (sizes 04-12) 40 (sizes 14-26)	CDDTLEV2	
IAG. COMP OFF	Diag Comp Unexpected Off	Enable/Disable		Enabled	CD_UEOFF	
CIR STUCK ON DIAG	Circuit Stuck On Diag.	Enable/Disable		Enabled	DCKTOFF	
CIR.A MIN DIS.P	Min discharge change	0 to 99	psi	11 (sizes 04-12) 17 (sizes 14-26)	MDP_DISA	
CIR.A MIN SUC.P	Min Suction change	0 to 99	psi	4 (sizes 04-06) 6.5 (size 07) 8 (size 08) 7 (sizes 09-12) 14 (sizes 14-26)	MDP_SUCA	
OFF P.RATIO	CirA P.Ratio off change	-1 to 1		-0.2 (sizes 07, 09-14) -0.3 (sizes 08, 17-26)	OFFPR_A	

CONTROL SET POINT AND CONFIGURATION LOG

Table AC — Settings Main Menu Layout (cont)

DISPLAY TEXT	EXPANDED TEXT	RANGE	UNITS	DEFAULT	POINT	ENTRY
ODF SETTINGS	Outdoor Fans Configurations Menu					
ODF SIGNAL QTY	Number of ODF Outputs	0 to 3		1 (sizes 04-06) 2 (sizes 07, 17, or 20) 3 (sizes 08-14, 24-26)	NUM_ODF	
ODF LOW COOL SPD	ODF Low Cool Speed	0 to 1200	rpm	1000 (size 04) 1075 (sizes 05-06) 550 (sizes 07-12) 700 (sizes 14-17, 26) 650 (sizes 20-24)	ODFLCSPD	
ODF MED COOL SPD	ODF Med Cool Speed	0 to 1200	rpm	1000 (size 04) 1075 (sizes 05-06) 700 (sizes 07, 12, or 24) 600 (size 08) 650 (size 09) 800 (sizes 14, 17, or 26) 750 (size 20)	ODFMCSPD	
ODF HIGH COOL SPD	ODF High Cool Speed	0 to 1200	rpm	1000 (size 04) 1075 (sizes 05-06) 950 (sizes 07 or 09) 900 (size 08) 1000 (sizes 12-26)	ODFHCSPD	
ODF MAXIMUM SPEED	ODF Maximum Speed	0 to 1200	rpm	1000 (size 04) 1075 (sizes 05-06) 950 (sizes 07 or 09) 900 (size 08) 1000 (sizes 12-26)	ODFMAXSP	
ODF MINIMUM SPEED	ODF Minimum Speed	0 to 1200	rpm	160	ODFMINS	
HEATING	Heating Configurations Menu					
UNIT TYPE OF HEAT	Type of Heat Installed	0=ELECTRIC, 1=GAS		0 (50 series) 1 (48 series) 2 (all except below); 0 (50 series without FLOP heat), 1 (50 Series, sizes 04-06 low or medium heat), 1 (50 series, sizes 07-14 and low heat), 1 (50 series, sizes 07-12 and medium heat)	HEATTYPE	
HEATING STAGE QTY	Number of Heating Stages	0 to 2			NUMHSTGS	
HEAT MIN ON	Heat Minimum On Time	60 to 600	sec	120	H_MINON	
HEAT MIN OFF	Heat Minimum Off Time	60 to 600	sec	120	H_MINOFF	
HEAT STAGEUP TIME	Heat Stage Increase Time	120 to 999	sec	450	HSTAGINC	
HEAT SATTREND LEV	Heating SAT Trend Level	-1 to 1.0	°F/min	0.2	SAT_TLH	
LOWER MAX SAT	Heat Max SAT Lower Level	85.0 to 200.0	°F	140	SATMAX_L	
UPPER MAX SAT	Heat Max SAT Upper Level	85.0 to 200.0	°F	160	SATMAX_H	
HEAT FANOFF DELAY	Heating Fan-off Delay	10 to 600	sec	30 (50 series) 45 (48 series)	HEAT_FOD	
HEAT LOCKOUT OAT	Heating Lockout Temp	40 to 125	°F	75	OATLHEAT	
SAT DURING HEAT?	SAT Heat Mode Sensing	Enable/Disable		Enable	SAT_HEAT	
IGC IFO TIMEOUT	No IGC IFO input Timeout	0 to 60	min	5	NO_IGCTM	
PREHEAT W/O IDF?	Pre-Heat HX without IDF?	Enable/Disable		Disable	PREHT_HX	
PREHEAT FAN DELAY	Pre-Heat Fan On Delay	0 to 120	sec	30	PREHT_TM	
SA TEMPER ENABLED	Supply Air Tempering Enable	Yes/No		Yes	SATEMPEN	

CONTROL SET POINT AND CONFIGURATION LOG

Table AC — Settings Main Menu Layout (cont)

DISPLAY TEXT	EXPANDED TEXT	RANGE	UNITS	DEFAULT	POINT	ENTRY
<i>HEATING (cont)</i>						
SA TEMPER SET PNT	SA tempering Setpoint	xx	°F	50	SATEMPSP	
TEMPER MAX OUT	Max OAT for SA tempering	-40 to 125	°F	48	OATSTEMP	
INDOOR FAN	Indoor Fan Configurations Menu					
INDOOR FAN TYPE	Indoor Fan Type	0=None, 1=VFD, 2=DIRECT DRIVE		1=VFD: all except Direct Drive motor Option 2 = DIRECT DRIVE: on 04-06 size with direct drive motors	IDFTYPE	
DIR.DRV IDF SPDS	Number Of Fan Speeds	2 to 3		2	NUMFSPDS	
OCCUPIED FAN?	Fan On When Occupied	Yes/No		Yes	FANON_OC	
MAXIMUM IDF SPEED	IDF Maximum Fan Speed	80 to 100	%	100	SPEEDMAX	
VENT IDF SPEED	Ventilation Only IDF Spd	0 to 100	%	50 (sizes 04-06) 67 (sizes 07-12) 53 (sizes 14 or 20) 56 (sizes 17) 52 (sizes 24) 60 (sizes 26)	FSPDVENT	
HEATING IDF SPD	Heating IDF Speed	20-100	%	100	FSPD_HT	
FREE COOL IDF SPD	Free Cooling IDF Speed	0-100	%	70 (size 04) 57 (sizes 05-06) 67 (sizes 07-12) 53 (sizes 14 or 20) 56 (sizes 17) 52 (sizes 24) 60 (sizes 26)	FSPD_FCL	
LOW COOL IDF SPD	Low Cooling IDF Speed	20-100	%	70 (size 04) 57 (sizes 05-06) 67 (sizes 07-12) 53 (sizes 14 or 20) 56 (sizes 17) 52 (sizes 24) 60 (sizes 26)	FSPD_LCL	
MED COOL IDF SPD	Med Cooling IDF Speed	20-100	%	87 (sizes 04) 71 (sizes 05) 69 (sizes 06) 67 (sizes 07-12) 79 (sizes 14) 82 (sizes 17) 62 (sizes 20) 65 (sizes 24) 72 (sizes 26)	FSPD_MCL	
HIGH COOL IDF SPD	High Cooling IDF Speed	20-100	%	100	FSPD_HCL	
SHUTDOWN IDF FAIL	Shut Down on IDF Failure	Yes/No		Yes	FATALFAN	
SHUTDOWN VFD HAND	VFD Hand Mode Shutdown?	Yes/No		Yes	HANDSHUT	
VFD IN REVERSE?	IDF VFD Motor In Reverse	Yes/No		No (sizes 04-12) Yes (sizes 14-26)	VFD1MDIR	
IDF VFD PARAMETERS	Indoor Fan VFD Settings Menu					
IDF VFD NOM. HP	IDF VFD Motor HP	1 to 26	HP	See VFD Motor Default Configuration Tables. Table 35 (sizes 04-06) Table 42 (Vert. sizes 07-26) Table 43 (Horz. Sizes 14-26)	MOTPWRHP	

CONTROL SET POINT AND CONFIGURATION LOG

Table AC — Settings Main Menu Layout (cont)

DISPLAY TEXT	EXPANDED TEXT	RANGE	UNITS	DEFAULT	POINT	ENTRY
<i>INDOOR FAN (cont)</i>						
IDF VFD VOLTAGE	IDF VFD Motor Volts	50 to 1000	V	See VFD Motor Default Configuration Tables. Table 35 (sizes 04-06) Table 42 (Vert. sizes 07-26) Table 43 (Horz. Sizes 14-26)	MOTVOLT	
IDF VFD NOM. FREQ	IDF VFD Motor Freq.	20 to 400	Hz	60	MOTFREQ	
IDF VFD NOM. AMPS	IDF VFD Motor Current	0.1 to 40	A	See VFD Motor Default Configuration Tables. Table 35 (sizes 04-06) Table 42 (Vert. sizes 07-26) Table 43 (Horz. Sizes 14-26)	MOTCUR	
IDF VFD NOM. RPM	IDF VFD Motor Nom. RPM	100 to 60000	rpm	See VFD Motor Default Configuration Tables. Table 35 (sizes 04-06) Table 42 (Vert. sizes 07-26) Table 43 (Horz. Sizes 14-26)	MOTNOMS P	
IDF VFD MIN REF	IDF Danfoss Min Ref	0 to 65	Hz	0	MINREF	
IDF VFD MAX REF	IDF Danfoss Max Ref	0 to 65	Hz	60	MAXREF	
VFD ACCEL. TIME	IDF VFD Accel. Time	1 to 1800	sec	10	RAMPUP_T	
VFD DECEL. TIME	IDF VFD Decel. Time	1 to 1800	sec	10	RAMPDN_T	
IDF VFD MAX AMPS	IDF VFD Max Current	0 to 655.35	A	See VFD Motor Default Configuration Tables. Table 35 (sizes 04-06) Table 42 (Vert. sizes 07-26) Table 43 (Horz. Sizes 07-26)	VFD1MAXA	
IDF VFD TIMEOUT	IDF Danfoss Comm. TO	1 to 600	sec	30	CNT_TOUT	
IDF VFD RESET DUR	IDF Danfoss Auto Reset	0 to 600	sec	30	ARSTRT_T	
VFD RFI FILTER	IDF Danfoss RFI Filter	On/Off		On	RFIFILTR	
ECONOMIZER						
Economizer Configurations Menu						
ECON INSTALLED?	Economizer Installed?	Yes/No		No: no FIOP Yes: FIOP	ECONO	
ECON MAX POS	Econ Max Damper Position	0 to 100	%	100	DAMPMAX	
ECON TRAVEL TIME	Economizer Travel Time	5 to 300	sec	150	ECONOTRV	
Minimum Position Configurations Menu						
MIN POS@ MAX FAN	Econ Min at Max Fan Speed	0 to 100	%	30	MINP_MAX	
MIN POS SPEED 1	Min Pos – User Speed 1	0 to 100	%	0	MP_USPD1	
MIN POS DAMP 1	Min Pos – User Pos 1	0 to 100	%	0	MP_UPOS1	
MIN POS SPEED 2	Min Pos – User Speed 2	0 to 100	%	0	MP_USPD2	
MIN POS DAMP 2	Min Pos – User Pos 2	0 to 100	%	0	MP_UPOS2	
MIN POS SPEED 3	Min Pos – User Speed 3	0 to 100	%	0	MP_USPD3	
MIN POS DAMP 3	Min Pos – User Pos 3	0 to 100	%	0	MP_UPOS3	
Free Cooling Specific Configurations Menu						
LOW COOL SAT SP	Low Free Cool SAT Setpnt	40 to 80	°F	65	LCSASP	
HIGH COOL SAT SP	High Free Cool SAT Setpnt	40 to 80	°F	55	HCSASP	
FREE COOL MAX OAT	Free Cooling Max OAT	0 to 90	°F	65	MAXFREET	
FREE COOL MIN OAT	Free Cooling Min Temp	-30 to 70	°F	0	MINFREET	
DIFF DRY BULB CTL	Diff. Dry Bulb Control	Enable/Disable		Disable	DIFFBULB	
DIFF DB DEADBAND	Diff. Dry Bulb Deadband	0 to 20	°F	3	OATRATDB	
ENTHALPY HI LIMIT	Max Enthalpy OA Limit	1.0 to 99.0	Btu/lb	28	FREEMAXE	

CONTROL SET POINT AND CONFIGURATION LOG

Table AC — Settings Main Menu Layout (cont)

DISPLAY TEXT	EXPANDED TEXT	RANGE	UNITS	DEFAULT	POINT	ENTRY
<i>ECONOMIZER (cont)</i>						
DIFF ENTHALPY CTL	Diff. Enthalpy Control	Enable/Disable		Disable	DIFFENTH	
ENTHALPY DEADBAND	Enthalpy Cross Deadband	0 to 20.0	Btu/lb	2	OAERAEDB	
UNOCCUPIED FREE COOL	Unoccupied Free Cooling Configs Menu					
WHEN TO UNOCC FC	When to Unocc Free Cool?	0=Disabled, 1=PreOcc, 2=Unocc		1=PreOcc	UFC_CFG	
UFC PREOCC TIME	UFC PreOcc Time	1 to 999	min	120	UFCTIME	
UFC LOW TEMP	Unocc Free Cool Low Temp	-30 to 70	°F	50	OATLUFC	
POWER EXHAUST CONFIGS	Power Exhaust Configurations Menu					
PE1 RELAY CHANNEL	PE1 Relay Channel	0=NONE, 1=MBB RLY11, 2=MBB RLY06		0: no FIOP 2: FIOP	PE1_CHAN	
PE1 POS@ MAX SPD	PE Stage 1 at Max speed	0 to 100	%	40	PE1_PMAX	
PE OFF DEADBAND	PE Turn Off Deadband	0 to 100	%	5	PE_OFFDB	
PE2 RELAY CHANNEL	PE2 Relay Channel	0=NONE, 1=MBB RLY11, 2=MBB RLY06		0=None	PE2_CHAN	
PE2 POS@ MAX SPD	PE Stage 2 at max speed	0 to 100	%	75	PE2_PMAX	
ECON ACT MECH DISC DIAG	Econ Actuator Mechanical disconnect diagnostic menu					
MDD-H/C END DLY	T24 Heat/Cool End Delay	0 to 60	min	25	T24CHDLY	
MDD- MIN MOVE	T24 Econ Min Move for SAT	10 to 20	%	10	T24ECSTS	
MDD-SAT DB	Damper SAT deadband	0 to 20.0	°F	12	T24SATDB	
MDD-MIN RAT-OAT	T24 Min Diff in RAT-OAT	5.0 to 20.0	°F	15	T24RATDF	
MDD-MIN TEST POS	T24 Test Minimum Pos	0 to 100	%	15	T24TSTMN	
MDD-MAX TEST POS	T24 Test Maximum Pos	0 to 100	%	85	T24TSTMX	
AIR QUALITY						
	Air Quality Configurations Menu					
ANALOG IAQ CTRL	Analog Input IAQ Control	0=NO IAQ, 1=DCV, 2=IAQ OVRD, 3=CTRL MINP		0: no FIOP 1: FIOP	IAQANCFG	
IAQ POS@ MAX SPD	IAQ Position at Max Fan	0 to 100	%	10	IAQMINP	
LOW AIR.Q DIFF	AQ Differential Low	0 to 5000	ppm	100	DAQ_LOW	
HIGH AIR.Q DIFF	AQ Differential High	0 to 5000	ppm	700	DAQ_HIGH	
PREOCC PURGE ENBL	IAQ Preoccupancy Purge	Yes/No		Yes	IAQPURGE	
PURGE POS@ MAX	IAQ Purge Pos at Max IDF	0 to 100	%	40	IAQPMAX	
PREOCC LOW LIMIT	Preocc Purge Lockout OAT	0 to 70	°F	50	IAQP_LA	
PREOCC PURGE TIME	Preocc Purge Duration	5 to 120	min	15	IAQPTIME	
AQ DIF HI-IAQ OVR	AQ Diff High IAQOVERRIDE	0 to 5000	ppm	700	AQD_HIGH	
AQ DIF LO-IAQ OVR	AQ Diff Low IAQ OVERRIDE	0 to 5000	ppm	100	AQD_LOW	
IAQ OVRD ENABLE	IAQ Override Enable	Yes/No	enum	No	IAQOVREN	
ALARM RELAY						
	Alarm Relay Configurations Menu					
ALM RELAY CHANNEL	ALM Relay Assigned Chan	0=NONE, 1=MBB RLY11, 2=MBB RLY06		1=MBB RLY11	ALM_CHAN	
THERMOSTAT ALERTS	Thermostat Alerts	Yes/No		Yes	TSTAT_AL	
HARDWARE ALERTS	Hardware Failures Alerts	Yes/No		Yes	HW_AL	
SAT/RAT ALERTS	SAT/RAT Sensor Alerts	Yes/No		Yes	SATRATAL	
OAT SENSOR ALERTS	OAT Thermistor Alerts	Yes/No		Yes	OATRL_AL	
SPACE SENS ALERTS	Space Sensors Alerts	Yes/No		Yes	SPACE_AL	
TRANSDUCER ALERTS	Transducer Sensor Alerts	Yes/No		Yes	TRANS_AL	
RH SENSOR ALERTS	RH Sensor Failure Alerts	Yes/No		Yes	RHS_AL	
CO2 SENSOR ALERTS	Air Quality CO ₂ Alerts	Yes/No		Yes	CO2S_AL	
OACFM SENS ALERTS	OACFM Alarm Relay	Yes/No		Yes	OACFM_AL	
ECONOMIZER ALERTS	Economizer Alerts	Yes/No		Yes	ECON_AL	
AIR FILTER ALERTS	Dirty Filter Alerts	Yes/No		Yes	FILT_AL	
GEN STATUS ALERTS	General Status Alerts	Yes/No		Yes	GENS_AL	
REFRIG CIR ALERTS	Refrig Circuit Alerts	Yes/No		Yes	CKT_AL	
COMPRESSOR ALERTS	Compressor Alerts	Yes/No		Yes	COMP_AL	
HEATING ALERTS	Heating Failure Alerts	Yes/No		Yes	HEAT_AL	

CONTROL SET POINT AND CONFIGURATION LOG

Table AC — Settings Main Menu Layout (cont)

DISPLAY TEXT	EXPANDED TEXT	RANGE	UNITS	DEFAULT	POINT	ENTRY
<i>ALARM RELAY (cont)</i>						
INDOOR FAN ALERTS	Indoor Fan Alerts	Yes/No		Yes	FAN_AL	
VFD ALERTS	VFD Alerts	Yes/No		Yes	VFD_AL	
IO BOARD ALERTS	Relay On Active IOBA	Yes/No		No	IOBFA_AL	
ON ACTIVE FAULTS	Relay on Active Faults	Yes/No		Yes	FAULT_AL	
SERVICE CONFIG MENU	Service Configuration Menu					
CMP FRAMEWORK	Compressor Framework	0=1CIR 2CMP, 1=1CMP+LDR, 2=1CMP		0 (sizes 07-26) 1 (sizes 04-06)	SYSVTYPE	
SHUTDWN A1 FIRST	Comp A1 Shutdown First	Yes/No		Yes (sizes 07-26) No (sizes 04-06)	SDWN_A1	
SHUTDWN ALD FIRST	Comp Loader Shutdown 1st	Yes/No		No (sizes 07-26) Yes (sizes 04-06)	SDWN_ALD	
SIOB1 INSTALLED	SIOB 1 Enabled	Yes/No		No: no Humidi-Mizer FIOF Yes: Humidi-Mizer FIOF	SIOB1_EN	
ECONO PID - KP	ECONO PID - KP	0.00 to 99.90		2.5	ECONO_P	
ECONO PID - KI	ECONO PID - KI	0.00 to 99.90		0.12	ECONO_I	
ECONO PID - KD	ECONO PID - KD	0.00 to 99.90		1	ECONO_D	
ECONO PID - RATE	ECONO PID - RATE	10 to 180	sec	15	ECONO_DT	
FBD PID Kp	FBD PID Kp	0 to 99.99999		0.01	FBDPID_P	
FBD PID Ki	FBD PID Ki	0 to 99.99999		0	FBDPID_I	
FBD PID Kd	FBD PID Kd	0 to 99.99999		0	FBDPID_D	
FBD KI RESET VAL	FBD Ki Reset Val.	0 to 99.9		0	FBDKIRES	
ODF ADVANCED CONFIGS	Outdoor Fan Advanced Configs Menu					
ODF GAIN	ODF Gain	-100 to 100		1 (sizes 07) 2 (sizes 08-12) 1.8 (sizes 14-20) 1.4 (sizes 04-06, 24-26)	ODF_KC	
ODF ANTI-WINDUP	ODF anti-windup factor	-100 to 100		0.6	ODF_NI	
ODF INTEGRAL TIME	ODF Integral Time	-100 to 100		20 (sizes 04-12) 40 (sizes 14-26)	ODF_TI	
ODF MBIAS 1	ODF Map Bias Term 1	-200 to 200		66.7 (sizes 07) -44.55 (sizes 08-12) 10 (sizes 14-20) 72.5 (sizes 04-06, 24-26)	ODFBIAS1	
ODF MBIAS 2	ODF Map Bias Term 2	-200 to 200		95.2 (sizes 07) 80.59 (sizes 08-12) 35.3 (sizes 14-20) 100.98 (sizes 04-06, 24-26)	ODFBIAS2	
ODF MBIAS 3	ODF Map Bias Term 3	-200 to 200		0 (sizes 07, 14-20) 20.93 (sizes 04-06) 65.29 (sizes 08-12) 114.74 (sizes 24-26)	ODFBIAS3	
ODF SWITCH POINT1	ODF Fans Switch Point 1	-100 to 100		3.68 (sizes 07) 3.4 (sizes 08-12) 4.84 (sizes 14-20) 1.58 (sizes 04-06, 24-26)	ODFPIUP1	
ODF SWITCH POINT2	ODF Fans Switch Point 2	-100 to 100		17.1 (sizes 07) 9.06 (sizes 08-12) 22.3 (sizes 14-20) 10.44 (sizes 04-06, 24-26)	ODFPIUP2	

CONTROL SET POINT AND CONFIGURATION LOG

Table AC — Settings Main Menu Layout (cont)

DISPLAY TEXT	EXPANDED TEXT	RANGE	UNITS	DEFAULT	POINT	ENTRY
<i>SERVICE CONFIG MENU (cont)</i>						
ODF SWITCH POINT3	ODF Fans Switch Point 3	-100 to 100		100 (sizes 07, 14-20) 19.76 (sizes 08-12) 20.93 (sizes 04-06, 24-26)	ODFPIUP3	
ODF PROP PR	ODF Proportional ctrl Pr	-100 to 100		25 (sizes 07-12) 50 (sizes 04-06, 14-26)	ODFPR_KC	
ODF MSLOPE 1	ODF Map Slope Term 1	-100 to 100		25.3 (sizes 07) 60.09 (sizes 08-12) 31 (sizes 14-20) 55.33 (sizes 04-06, 24-26)	ODFSLPE1	
ODF MSLOPE 2	ODF Map Slope Term 2	-100 to 100		9 (sizes 07) 18.69 (sizes 08-12) 9.6 (sizes 14-20) 19.07 (sizes 04-06, 24-26)	ODFSLPE2	
ODF MSLOPE 3	ODF Map Slope Term 3	-100 to 100		1 (sizes 07, 14-20) 9.34 (sizes 08-12) 8.85 (sizes 04-06, 24-26)	ODFSLPE3	
NEW HARDWARE	Quick Menu for New Hardware					
UNIT CONTROL TYPE	Unit Control Type	0=TSTAT, 1=SPACE SEN, 2=RAT SEN		0=TSTAT	CTRLTYPE	
ECON INSTALLED?	Economizer Installed?	Yes/No		No: no FIOP Yes: FIOP	ECONO	
SPRH SENS CHANNEL	SPRH Assigned Channel	0=None, 1=MBB Ai06, 2=MBB Ai07, 3=MBB Ai08, 4=SI0B Ai10		0=None	SPRHCHAN	
IAQ SENSOR CHAN	IAQ Assigned Channel	0=None, 1=MBB Ai06, 2=MBB Ai07, 3=MBB Ai08		1: no FIOP 0: FIOP	IAQ_CHAN	
OAQ SENSOR CHAN	OAQ Assigned Channel	0=None, 1=MBB Ai06, 2=MBB Ai07, 3=MBB Ai08		0=None	OAQ_CHAN	
OARH SENSOR CHAN	OARH Assigned Channel	0=None, 1=MBB Ai06, 2=MBB Ai07, 3=MBB Ai08		3: no FIOP 0: FIOP	OARHCHAN	
RARH SENS CHANNEL	RARH Assigned Channel	0=None, 1=MBB Ai06, 2=MBB Ai07, 3=MBB Ai08		0=None	RARHCHAN	
OACFM SENS CHANNEL	OACFM Assigned Channel	0=None, 1=MBB Ai06, 2=MBB Ai07, 3=MBB Ai08, 4=SI0B Ai10		0=None	OACFMCHAN	
FIRE SHUTDOWN SW	Fire Shutdown Switch	0=NORM OPEN, 1=NORM CLSD, 2=NO SWITCH		2: no FIOP 0: FIOP	FIRE_CFG	
FILTER SW CHANNEL	Filter Status Sw Channel	0=None, 1=MBB DI12, 2=MBB DI13, 3=MBB DI14, 4=MBB DI02, 5=MBB DI04		0=None	FILTCHAN	
REMOTE OCC CHAN	Remote Occupancy Channel	0=None, 1=MBB DI12, 2=MBB DI13, 3=MBB DI14, 4=MBB DI02, 5=MBB DI04		0=None	RMOCCHAN	

CONTROL SET POINT AND CONFIGURATION LOG

Table AC — Settings Main Menu Layout (cont)

DISPLAY TEXT	EXPANDED TEXT	RANGE	UNITS	DEFAULT	POINT	ENTRY
<i>NEW HARDWARE (cont)</i>						
REM.SHUTDOWN CHAN	Remote Shutdown Channel	0=None, 1=MBB DI12, 2=MBB DI13, 3=MBB DI14, 4=MBB DI02, 5=MBB DI04		0=None	ROFFCHAN	
COFS CHANNEL	COFS Assigned Channel	0=None, 1=MBB DI12, 2=MBB DI13, 3=MBB DI14, 4=MBB DI02, 5=MBB DI04		0=None	COFCHAN	
GEN STATUS CHAN	General Status Channel	0=None, 1=MBB DI12, 2=MBB DI13, 3=MBB DI14, 4=MBB DI02, 5=MBB DI04		0=None	GEN_CHAN	
ENTHALPY SW CHAN	Enthalpy Sw Channel	0=None, 1=MBB DI12, 2=MBB DI13, 3=MBB DI14, 4=MBB DI02, 5=MBB DI04		0=None	ENTHCHAN	
NETWORK SETTINGS	Building Network Configurations Menu					
BAS PROTOCOL	BAS Protocol Select	0=NONE, 1=CCN, 2=BACNET	x	0=NONE	BMS_CFG	
NETWORK TIMEOUT	Network Input Timeout	0 to 600	min	30	NETINTO	
CCN	CCN Network Configuration Menu					
BUS NUMBER	CCN Bus Number	0 to 239		0	CCNBUS	
CCN ELEMENT #	CCN Element Number	1 to 239		1	CCNADD	
CCN BAUDRATE	CCN Baud Rate	0=9600, 1=19200, 2=38400		2=38400	BAUDENUM	
BROADCAST ACK?	CCN Broadcast Ack'er	Yes/No		No	CCNBCACK	
BROADCAST SCHEDL?	Global Schedule Broadcast	Yes/No		No	CCN_GSBC	
BROADCAST TIME?	CCN Time Broadcast	Yes/No		No	CCNBC	
BROADCAST OAT?	Broadcast OAT On Network	Yes/No		No	OATBC	
BROADCAST OARH?	Broadcast OARH On Network	Yes/No		No	OARHBC	
BROADCAST OAQ?	Broadcast OAQ On Network	Yes/No		No	OAQBC	
BROADCAST IAQ?	Broadcast IAQ On Network	Yes/No		No	IAQBC	
LOCATION	Device Location	text string		<blank>	DEV_LOC	
REFERENCE NUMBER	Reference number	text string		<blank>	REF_NUM	
BACNET	BACnet network configuration menu					
MAC ADDRESS	BACnet Device Macaddress	1 to 127		01	BAC_MAC	
BACNET BAUDRATE	BACnet BMS baud rate	0=9600, 1=19200, 2=38400, 3=57600, 4=76800, 5=115200		4=76800	BAC_BAUD	
AUTO ID SCHEME	ALC Auto ID Scheme	Yes/No		Yes	AUID	
BACNET AUTO ID	BACnet ID Auto ID	Yes/No		Yes	BAC_AUID	
BACNET ID	BACnet ID Number	0 to 4194302		1610101	BAC_ID	
LINKAGE SETTINGS	LINKAGE SETTINGS MENU					
DEVICE IAQ	BACnet device for IAQ	0 to 4194303		1610100	DEVIAQ	
OBJECT ID IAQ	Object instance for IAQ	0 to 9999		1009	OBJIAQ	
COV IAQ	Change of value for IAQ	0 to 60		0	COVIAQ	
DEVICE OAQ	BACnet device for OAQ	0 to 4194303		1610100	DEVOAQ	
OBJECT ID OAQ	Object instance for OAQ	0 to 9999		285	OBJOAOQ	
COV OAQ	Change of value for OAQ	0 to 60		0	COVOAQ	
DEVICE OARH	BACnet device for OARH	0 to 4194303		1610100	DEVOARH	
OBJECT ID OARH	Object instance for OARH	0 to 9999		1022	OBJOARH	
COV OARH	Change of value for OARH	0 to 60		0	COVOARH	
DEVICE OAT	BACnet device for OAT	0 to 4194303		1610100	DEVOAT	

CONTROL SET POINT AND CONFIGURATION LOG

Table AC — Settings Main Menu Layout (cont)

DISPLAY TEXT	EXPANDED TEXT	RANGE	UNITS	DEFAULT	POINT	ENTRY
<i>NETWORK SETTINGS (cont)</i>						
OBJECT ID OAT	Object instance for OAT	0 to 9999		1003	OBJOAT	
COV OAT	Change of value for OAT	0 to 60		0	COVOAT	
DEVICE RARH	BACnet device for RARH	0 to 4194303		1610100	DEVRARH	
OBJECT ID RARH	Object instance for RARH	0 to 9999		30	OBJRARH	
COV RARH	Change of value for RARH	0 to 60		0	COVRARH	
DEVICE RAT	BACnet device for RAT	0 to 4194303		1610100	DEVSTAT	
OBJECT ID RAT	Object instance for RAT	0 to 9999		1010	OBJRAT	
COV RAT	Change of value for RAT	0 to 60		0	COVRAT	
DEVICE SPT	BACnet device for SPT	0 to 4194303		1610100	DEVSPT	
OBJECT ID SPT	Object instance for SPT	0 to 9999		2007	OBJSPT	
COV SPT	Change of value for SPT	0 to 60		0	COVSPT	
LOCAL_SHEDL_EDIT	Allow Local Sched Edit	Yes/No	enum	No	LCL_EDIT	
SYSTEM TOUCH	System Touch Menu					
DEVICE INSTANCE	System Touch Device Inst	0 to 4194303		160099	DEVST	
POLLING RATE	System Touch Poll Rate	10 to 60		10	POLLST	
SPACE TEMP AI	System Touch AI for SPT	0 to 9999		1	AISTPT	
SPACE RH AI	System Touch AI for SPRH	0 to 9999		4	AISTSPRH	
ZS SENSOR CFG	ZS Sensor Configuration					
ZS1 ADDRESS	Zone Sensor 1 Address	0 to 255		255	ZSADDR1	
ZS2 ADDRESS	Zone Sensor 2 Address	0 to 255		255	ZSADDR2	
ZS3 ADDRESS	Zone Sensor 3 Address	0 to 255		255	ZSADDR3	
ZS4 ADDRESS	Zone Sensor 4 Address	0 to 255		255	ZSADDR4	
ZS5 ADDRESS	Zone Sensor 5 Address	0 to 255		255	ZSADDR5	
ZS POLL RATE	Zone Sensor Poll Rate	1 to 100	sec	5	ZSPOLLRT	
ZS UNIT	Zone Sensor Unit	0=degrees F		0=degrees F	ZSUNIT	
ZS FRC UNOC ENBL	ZS Force Unoccup Enable	No		No	ZSFUNEN	
ZS FRC UNOC DELAY	ZS Force Unocc wt Delay	No		No	ZSFUNWT	
ZS TLO CONT ENBL	ZS TLO Cont Enable	No		No	ZSTLOEN	
TLO SET DURING OC	ZS TLO set during occ	No		No	ZSTLSOC	
ZS UI MODE	Zone sensor UI Mode	1=Dual Offsets		1=Dual Offsets	ZSUIM	
NETWORK CHKLIST	NETWORK SETUP CHECKLIST	0=Undone, 1=Perform, 2=Done		0=Undone	CHK_NET	
DISPLAY SETTINGS						
METRIC DISPLAY	User Display Configurations Menu			No	DISPUNIT	
LANGUAGE	Metric Display	Yes/No		No	DISPUNIT	
CONTRAST ADJUST	Display Language Select	0=English		0=English	LANGUAGE	
PASSWORD ENABLE?	LCD Contrast Adjustment	1 to 10		5	LCD_CONT	
VIEW USER PASSWORD	User Password Protection	Enable/Disable		Enable	PASS_EBL	
CHANGE USER PASSWORD	View User Password Menu					
CHANGE USER PASSWORD	Change User Password Menu					
QUICK SETUP CONFIG						
TIME	QUICK SETUP CONFIG MENU					
DATE	Clock Hour and Minute	xx:xx	hh.mm	0	TIME	
STARTUP DELAY	Current Date	MM/DD/YYYY		0	DATE	
UNIT CONTROL TYPE	Unit Startup Delay	10 to 600	sec	30	STARTDLY	
THERMOSTAT TYPE	Unit Control Type	0=TSTAT, 1=SPACE SEN, 2=RAT SEN		0=TSTAT	CTRLTYPE	
DIRTY FILTER TIME	Thermostat Hardware Type	0=CONV 2C2H, 1=DIGI 2C2H, 2=CONV 3C2H, 3=DIGI 3C2H, 4=DIGI 2C2H		2=CONV 3C2H	STATTYPE	
VENT IDF SPEED	Change Filter Timer	0 to 9999	hours	600	FILTIFE	
				50 (sizes 04-06) 67 (sizes 07-12) 53 (sizes 14 or 20)		
				56 (size 17) 52 (size 24) 60 (size 26)	FSPDVENT	

Table AC — Settings Main Menu Layout (cont)

DISPLAY TEXT	EXPANDED TEXT	RANGE	UNITS	DEFAULT	POINT	ENTRY
<i>QUICK SETUP CONFIG (cont)</i>						
HEATING STAGE QTY	Number of Heating Stages	0 to 2		2 (all except below): 0 (50 series without FIOp heat), 1 (50 series, sizes 04-06 low or medium heat), 1 (50 series, sizes 07-14 and low heat), 1 (50 series, sizes 07-12 and medium heat)	NUMHSTGS	
ECON INSTALLED?	Economizer Installed?	Yes/No		No: no FIOp Yes: FIOp	ECONO	
FREE COOL MAX OAT	Free Cooling Max OAT	0 to 90	°F	65		
FIRE SHUTDOWN SW	Fire Shutdown Switch	0=NORM OPEN, 1=NORM CLSD, 2=NO SWITCH		2: no FIOp 0: FIOp	FIRE_CFG	
QUICK SET CHKLIST	QUICK SETUP CHECKLIST	0=Undone, 1=Perform, 2=Done		0=Undone	CHK_QUIK	

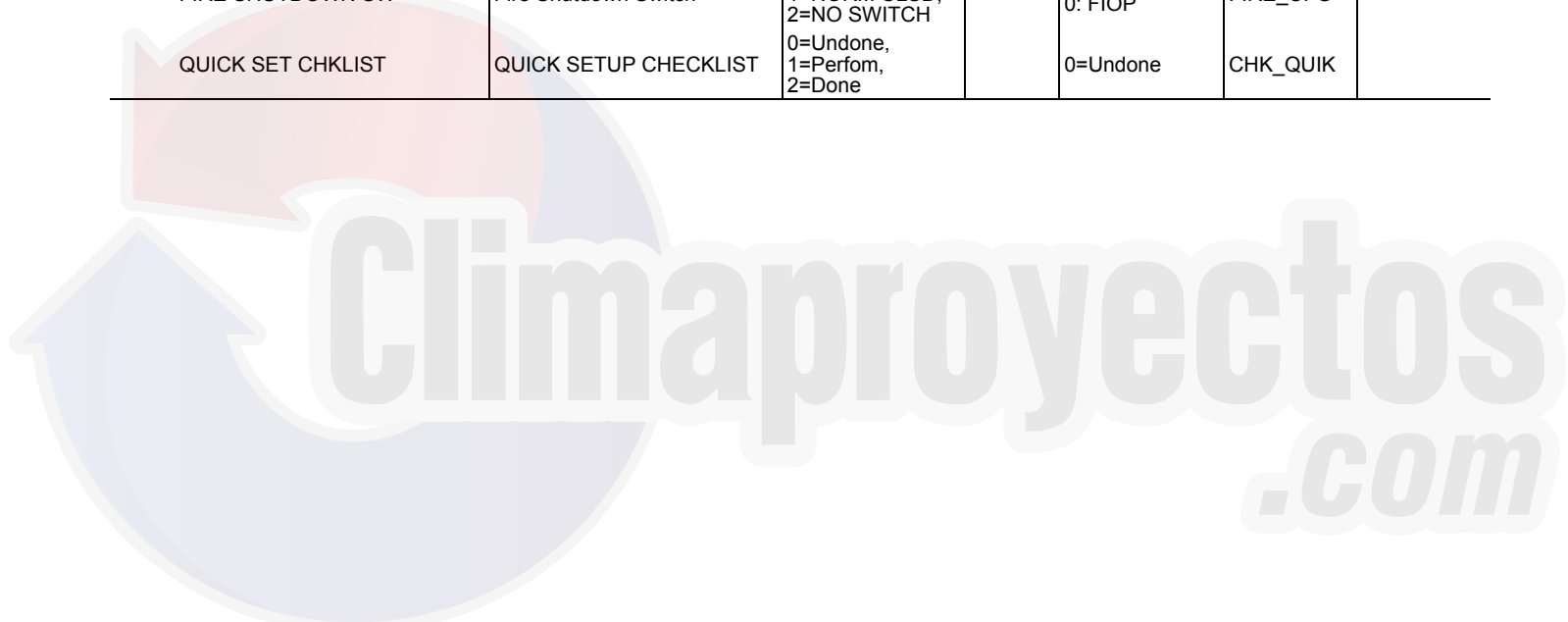



UNIT START-UP CHECKLIST

(Remove and use for job file)

NOTE: To avoid injury to personnel and damage to equipment or property when completing the procedures listed in this start-up checklist, use good judgment, follow safe practices, and adhere to the safety considerations/information as outlined in preceding sections of this Controls, Start-Up, Operation, and Troubleshooting document.

I. PRELIMINARY INFORMATION

MODEL NO _____

JOB NAME _____

SERIAL NO _____

ADDRESS _____

START-UP DATE _____

TECHNICIAN NAME _____

ADDITIONAL ACCESSORIES _____

II. PRE-START-UP

Verify that all packaging materials have been removed from unit (Y/N) _____
Verify installation of outdoor air hood (Y/N) _____
Verify installation of flue exhaust and inlet hood (48LC only) (Y/N) _____
Verify that condensate connection is installed per instructions (Y/N) _____
Verify that all electrical connections and terminals are tight (Y/N) _____
Verify gas pressure to unit gas valve is within specified range (48LC only) (Y/N) _____
Check gas piping for leaks (48LC only) (Y/N) _____
Check that indoor-air filters are clean and in place (Y/N) _____
Check that outdoor air inlet screens are in place (Y/N) _____
Verify that unit is level (Y/N) _____
Check fan wheels and propeller for location in housing/orifice and verify setscrew is tight (Y/N) _____
Verify that fan sheaves are aligned and belts are properly tensioned (Y/N) _____
Verify that scroll compressors are rotating in the correct direction (Y/N) _____
Verify installation of thermostat/space sensor (Y/N) _____
Verify that crankcase heaters have been energized for at least 24 hours (48LC only) (Y/N) _____
Verify configuration values for electronic controls (refer to control set-up checklist) (Y/N) _____

III. START-UP

ELECTRICAL

Supply Voltage	L1-L2 _____	L2-L3 _____	L3-L1 _____
Compressor 1Amps	L1 _____	L2 _____	L3 _____
Compressor 2 Amps / Stage 2 Amps	L1 _____	L2 _____	L3 _____
Supply Fan Amps	L1 _____	L2 _____	L3 _____
Outdoor Fan Amps	L1 _____	L2 _____	

TEMPERATURES

Outdoor-air Temperature	_____ °F DB (Dry Bulb)	_____ °F WB (Wet Bulb)
Return-air Temperature	_____ °F DB	_____ °F WB
Cooling Supply Air Temperature	_____ °F DB	_____ °F WB
Gas Heat Supply Air (48LC)	_____ °F DB	_____ °F WB
Electric Heat Supply Air (50LC)	_____ °F DB	_____ °F WB

Manufacturer reserves the right to discontinue, or change at any time, specifications or designs without notice and without incurring obligations.

PRESSURES

Gas Inlet Pressure in. wg (48LC) _____ in. wg
 Gas Manifold Pressure (48LC) STAGE 1 _____ in. wg
 STAGE 2 _____ in. wg
 Refrigerant Suction CIRCUIT A _____ PSIG
 CIRCUIT A (superheat) _____ °F
 Refrigerant Discharge CIRCUIT A _____ PSIG
 CIRCUIT A (subcooling) _____ °F
 Verify Refrigerant Charge using Charging Charts (Y/N) _____

GENERAL

Economizer minimum vent and changeover settings to job requirements (if equipped) (Y/N) _____

IV. HUMIDI-MIZER® SYSTEM START-UP

STEPS

1. Start unit In cooling (Close Y1) (Y/N) _____

OBSERVE AND RECORD

- A. Suction pressure _____ PSIG
- B. Discharge pressure _____ PSIG
- C. Entering air temperature _____ ° F
- D. Leaving air temperature _____ ° F

2. Switch unit to mixed cool and reheat mode (subcool) (Y/N) _____

OBSERVE

- A. Reduction in suction pressure (5 to 7 psi expected) (Y/N) _____
- B. Discharge pressure unchanged (Y/N) _____
- C. Delta temperature decreases, close to neutral air (Y/N) _____

3. Switch unit to hot gas reheat mode.

OBSERVE

- A. Suction pressure increases to normal cooling level
 - B. Discharge pressure decreases (35 to 50 psi) (Limited by head pressure control)
 - C. Liquid temperature returns to normal cooling level
4. With unit in dehumid mode switch to heating and verify compressor and outdoor fan stop (Y/N) _____
5. Turn off heating, cooling, and reheat, restore set points for thermostat and humidistat (Y/N) _____

REPEAT PROCESS FOR 2 COMPRESSOR SYSTEMS

CUT ALONG DOTTED LINE