



Installation Instructions

48TC 07 units for installation in the United States contain use of Carrier's Staged Air Volume (SAV™) 2-speed indoor fan control system. This complies with the U.S. Department of Energy (DOE) efficiency standard of 2018.

48TC 07 units for installation outside the United States may or may not contain use of the SAV 2-speed indoor fan control system as they are not required to comply with the U.S. Department of Energy (DOE) efficiency standard of 2018.

For specific details on operation of the Carrier SAV 2-speed indoor fan system refer to the Variable Frequency Drive (VFD) Factory-Installed Option 2-Speed Motor Control Installation, Setup, and Troubleshooting manual.

CONTENTS

	Page
GENERAL	1
SAFETY CONSIDERATIONS	1-6
INSTALLATION	6-43
Job-Site Survey	6
Step 1 — Plan for Unit Location	6
Step 2 — Plan for Sequence of Unit Installation	7
• CURB-MOUNTED INSTALLATION	
• PAD-MOUNTED INSTALLATION	
• FRAME-MOUNTED INSTALLATION	
Step 3 — Inspect Unit	7
Step 4 — Provide Unit Support	7
• ROOF CURB MOUNT	
• SLAB MOUNT (HORIZONTAL UNITS ONLY)	
• ALTERNATE UNIT SUPPORT (IN LIEU OF CURB OR SLAB MOUNT)	
Step 5 — Field Fabricate Ductwork	9
Step 6 — Rig and Place Unit	9
• POSITIONING ON CURB	
Step 7 — Convert to Horizontal and Connect Ductwork (When Required)	10
Step 8 — Install Outside Air Hood	10
• ECONOMIZER AND TWO POSITION DAMPER HOOD PACKAGE REMOVAL AND SETUP — FACTORY OPTION	
• ECONOMIZER HOOD AND TWO-POSITION HOOD	
Step 9 — Install Flue Hood	11
Step 10 — Install Gas Piping	11
• FACTORY-OPTION THRU-BASE CONNECTIONS (GAS CONNECTIONS)	
Step 11 — Install External Condensate Trap and Line	14
Step 12 — Make Electrical Connections	14
• FIELD POWER SUPPLY	
• UNITS WITH FACTORY-INSTALLED NON-FUSED DISCONNECT	
• UNITS WITHOUT FACTORY-INSTALLED NON-FUSED DISCONNECT	
• CONVENIENCE OUTLETS	
• FACTORY-OPTION THRU-BASE CONNECTIONS (ELECTRICAL CONNECTIONS)	

• HUMIDI-MIZER® CONTROL CONNECTION	
• ECONOMIZER X (FACTORY-INSTALLED OPTION)	
• ECONOMIZER MODULE WIRING DETAILS	
• INTERFACE OVERVIEW	
• PREMIERLINK™ (FACTORY-OPTION)	
• PREMIERLINK FIELD CONNECTIONS	
• ECONOMIZER CONTROLS	
• RTU OPEN CONTROL SYSTEM	
• RTU OPEN CONTROL SYSTEM FIELD CONNECTIONS	
• RTU OPEN COMMUNICATION WIRING PROTOCOLS	
• LOCAL ACCESS	
• OUTDOOR AIR ENTHALPY CONTROL	
• SMOKE DETECTORS	
Step 13 — Adjust Factory-Installed Options	57
• SMOKE DETECTORS	
• ECONOMIZER IV OCCUPANCY SWITCH	
Step 14 — Install Accessories	57
Step 15 — Check Belt Tension	57
• BELT FORCE — DEFLECTION METHOD	
• BELT TENSION METHOD	
Pre-Start and Start-Up	58
START-UP CHECKLIST	CL-1, CL-2

GENERAL

These installation instructions cover the 48TC units with gas heat and electric cooling. Units are pre-wired and pre-charged with environmentally sound Puron® (R-410A) refrigerant at the factory. See Fig. 1 for model number nomenclature. See Fig. 2 for unit dimensions. See Fig. 3 for service clearances.

SAFETY CONSIDERATIONS

Improper installation, adjustment, alteration, service, maintenance, or use can cause explosion, fire, electrical shock or other conditions which may cause personal injury or property damage. Consult a qualified installer, service agency, or your distributor or branch for information or assistance. The qualified installer or agency must use factory-authorized kits or accessories when modifying this product. Refer to the individual instructions packaged with the kits or accessories when installing.

Follow all safety codes. Wear safety glasses and work gloves. Use quenching cloths for brazing operations and have a

fire extinguisher available. Read these instructions thoroughly and follow all warnings or cautions attached to the unit. Consult local building codes and appropriate national electrical codes (in USA, ANSI/NFPA70, National Electrical Code (NEC); in Canada, CSA C22.1) for special requirements.

It is important to recognize safety information. This is the safety-alert symbol. When you see this symbol on the unit and in instructions or manuals, be alert to the potential for personal injury.

Understand the signal words DANGER, WARNING, CAUTION, and NOTE. These words are used with the safety-alert symbol. DANGER identifies the most serious hazards which will result in severe personal injury or death. WARNING signifies hazards which could result in personal injury or death. CAUTION is used to identify unsafe practices, which may result in minor personal injury or product and property damage. NOTE is used to highlight suggestions which will result in enhanced installation, reliability, or operation.

⚠ WARNING

Failure to follow this warning could result in personal injury or death. Disconnect gas piping from unit when leak testing at pressure greater than 0.5 psig (3450 Pa). Pressures greater than 0.5 psig (3450 Pa) will cause gas valve damage resulting in hazardous condition. If gas valve is subjected to pressure greater than 0.5 psig (3450 Pa), it must be replaced before use. When pressure testing field-supplied gas piping at pressures of 0.5 psig (3450 Pa) or less, a unit connected to such piping must be isolated by closing the manual gas valve.

⚠ WARNING

Failure to follow this warning could cause personal injury or death. Before performing service or maintenance operations on unit, always turn off main power switch to unit and install lock(s) and lockout tag(s). Unit may have more than one power switch.

⚠ WARNING

Failure to follow this warning could cause personal injury, death and/or equipment damage.

Puron (R-410A) refrigerant systems operate at higher pressures than standard R-22 systems. Do not use R-22 service equipment or components on Puron refrigerant equipment.

⚠ WARNING

Failure to follow this warning could cause personal injury or death.

Relieve pressure and recover all refrigerant before system repair or final unit disposal.

Wear safety glasses and gloves when handling refrigerants. Keep torches and other ignition sources away from refrigerants and oils.

⚠ CAUTION

Failure to follow this caution may result in personal injury. Sheet metal parts may have sharp edges or burrs. Use care and wear appropriate protective clothing, safety glasses and gloves when handling parts and servicing air conditioning equipment.

Rated Indoor Airflow (cfm) — Table 1 lists the rated indoor airflow used for the AHRI efficiency rating for the units covered in this document.

Table 1 — AHRI Efficiency — Rated Indoor Airflow

MODEL NUMBER	FULL LOAD AIRFLOW (CFM)
48TC*A04	1275
48TC*A05	1400
48TC*A06	1800
48TC*A/B07	2200

Position:	1	2	3	4	5	6	7	8	9	10	11	12	13	14	15	16	17	18
Example:	4	8	T	C	D	A	0	4	A	1	A	5	-	0	A	0	A	0

Unit Heat Type
48 - Gas Heat Packaged Rooftop

Model Series - WeatherMaker®
TC - Standard Efficiency

Heat Options
D = Low Heat
E = Medium Heat
F = High Heat
L = Low NO_x, Low Heat
M = Low NO_x, Medium Heat
N = Low NO_x, High Heat
S = Low Heat w/ Stainless Steel Exchanger
R = Medium Heat w/ Stainless Steel Exchanger
T = High Heat w/ Stainless Steel Exchanger

Refrig. Systems Options
A = Standard One Stage Cooling Models
B = Standard One Stage Cooling Models with Humidi-MiZer® (07 models only)

Cooling Tons
04 = 3 tons
05 = 4 tons
06 = 5 tons
07 = 6 tons

Sensor Options
A = None
B = RA Smoke Detector
C = SA Smoke Detector
D = RA + SA Smoke Detector
E = CO₂
F = RA Smoke Detector and CO₂
G = SA Smoke Detector and CO₂
H = RA + SA Smoke Detector and CO₂

Indoor Fan Options
0 = Direct Drive, Standard Static Option (04/05/06 models only)
1 = Belt Drive, Standard Static Option
2 = Belt Drive, Medium Static Option
3 = Belt Drive, High Static Option

Coil Options – RTPF (Outdoor - Indoor - Hail Guard)
A = Al/Cu - Al/Cu
B = Precoat Al/Cu - Al/Cu
C = E-coat Al/Cu - Al/Cu
D = E-coat Al/Cu - E-coat Al/Cu
E = Cu/Cu - Al/Cu
F = Cu/Cu - Cu/Cu
M = Al/Cu - Al/Cu — Louvered Hail Guard
N = Precoat Al/Cu - Al/Cu — Louvered Hail Guard
P = E-coat Al/Cu - Al/Cu — Louvered Hail Guard
Q = E-coat Al/Cu - E-coat Al/Cu — Louvered Hail Guard
R = Cu/Cu - Al/Cu — Louvered Hail Guard
S = Cu/Cu - Cu/Cu — Louvered Hail Guard

Coil Options – Novation (Outdoor - Indoor - Hail Guard)
G = Al/Al - Al/Cu
H = Al/Al - Cu/Cu
J = Al/Al - E-coat Al/Cu
K = E-coat Al/Al - Al/Cu
L = E-coat Al/Al - E-coat Al/Cu
T = Al/Al - Al/Cu — Louvered Hail Guard
U = Al/Al - Cu/Cu — Louvered Hail Guard
V = Al/Al - E-coat Al/Cu — Louvered Hail Guard
W = E-coat Al/Al - Al/Cu — Louvered Hail Guard
X = E-coat Al/Al - E-coat Al/Cu — Louvered Hail Guard

Packaging & Seismic Compliance
0 = Standard
1 = LTL
3 = California Seismic Compliant Label
4 = LTL and CA Seismic Compliant Label

Electrical Options
A = None
C = Non-Fused Disconnect
D = Thru-The-Base Connections
F = Non-Fused Disconnect and Thru-The-Base Connections
G = 2 Speed Indoor Fan (SAV)

Service Options
0 = None
1 = Unpowered Convenience Outlet
2 = Powered Convenience Outlet
3 = Hinged Panels
4 = Hinged Panels and Unpowered Convenience Outlet
5 = Hinged Panels and Powered Convenience Outlet

Intake / Exhaust Options
A = None
B = Temperature Economizer w/ Barometric Relief
F = Enthalpy Economizer w/ Barometric Relief
K = 2-Position Damper
U = Temperature Ultra Low Leak Economizer w/ Barometric Relief
W = Enthalpy Ultra Low Leak Economizer w/ Barometric Relief

Base Unit Controls
0 = Electro-mechanical Controls can be used with W7212 EconoMiSer® IV (Non-Fault Detection and Diagnostic)
1 = PremierLink™ Controller*
2 = RTU Open Multi-Protocol Controller
6 = Electro-mechanical w/ 2-Speed Fan and W7220 Economizer Controller Controls. Can be used with W7220 EconoMiSer X (w/ Fault Detection & Diagnostic)

Design Revision
- = Factory Design Revision

Voltage
1 = 575/3/60
3 = 208-230/1/60
5 = 208-230/3/60
6 = 460/3/60

* PremierLink™ cannot be used with Staged Air Volume (SAV™) 2-speed indoor fan motor.

NOTES:

- On single phase (-3 voltage code) models, the following are not available as a factory-installed option:
 - Coated Coils or Cu Fin Coils
 - Louvered Hail Guards
 - Economizer or 2 Position Damper
 - Powered 115-volt Convenience Outlet
- Staged Air Volume (SAV™) is available on size 07 only.

Fig. 1 — 48HC04-07 Units Model Number Nomenclature**

THIS DOCUMENT IS THE PROPERTY OF CARRIER CORPORATION. IT IS TO BE USED ONLY FOR THE PROJECT AND CONTENTS SHALL NOT BE REPRODUCED OR USED WITHOUT CARRIER CORPORATION'S WRITTEN CONSENT.



SUBMISSION OF THESE DRAWINGS OR DOCUMENTS DOES NOT CONSTITUTE PART PERFORMANCE OR ACCEPTANCE OF CONTRACT.

UNIT	J	K
48TC-A04	33-3/8 [847]	18-5/8 [472]
48TC-A05	33-3/8 [847]	14-7/8 [377]
48TC-A06	33-3/8 [847]	14-7/8 [377]
48TC-A07	41-3/8 [1051]	14-7/8 [377]

- NOTES:
1. DIMENSIONS ARE IN INCHES. DIMENSIONS IN [] ARE IN MILLIMETERS.
 2. CENTER OF GRAVITY
 3. DIRECTION OF AIR FLOW

CONNECTION SIZES	
A	1 3/8" [35] DIA. FIELD POWER SUPPLY HOLE
B	2" [50] DIA. POWER SUPPLY KNOCKOUT
C	1 3/4" [45] DIA. GAUGE ACCESS PLUG
D	7/8" [22] DIA. FIELD CONTROL WIRING HOLE
E	3/4"-14 NPT CONDENSATE DRAIN
F	1/2"-14 NPT GAS CONNECTION
G	2 1/2" [64] DIA. POWER SUPPLY KNOCK-OUT

THRU-THE-BASE CHART THESE FITTINGS ARE FOR USE CIB-IMPWR001A01 - 003A01	
W	1/2" ACC. 7/8" [22.2]
X	1/2" 24V 7/8" [22.2]
Y	3/4" [001.003] POWER 1 1/8" [28.4]
Z**	[003] 1/2" FPT GAS 1 3/16" [30.0]

FOR "THRU-THE-BASE" FACTORY OPTION, FITTINGS FOR ONLY X, Y, & Z ARE PROVIDED. SELECT EITHER 3/4" OR 1/2" FOR POWER, DEPENDING ON WIRE SIZE. (001) PROVIDES 3/4" FPT THRU CURB FLANGE & FITTING.

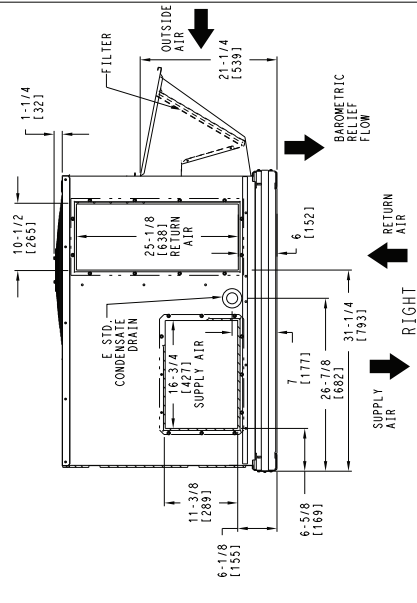
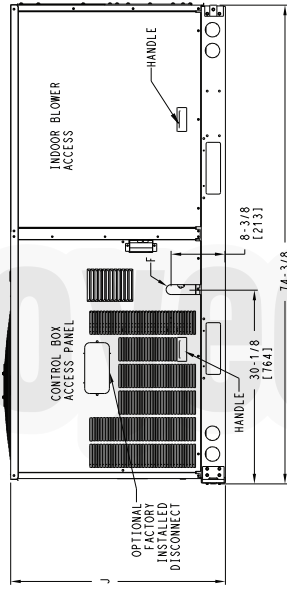
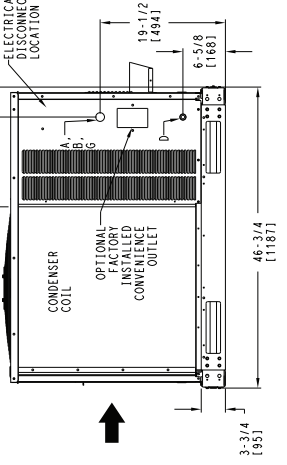
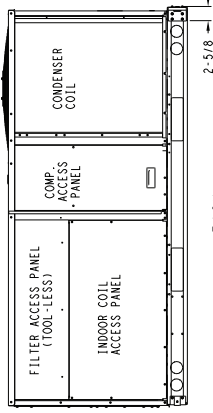
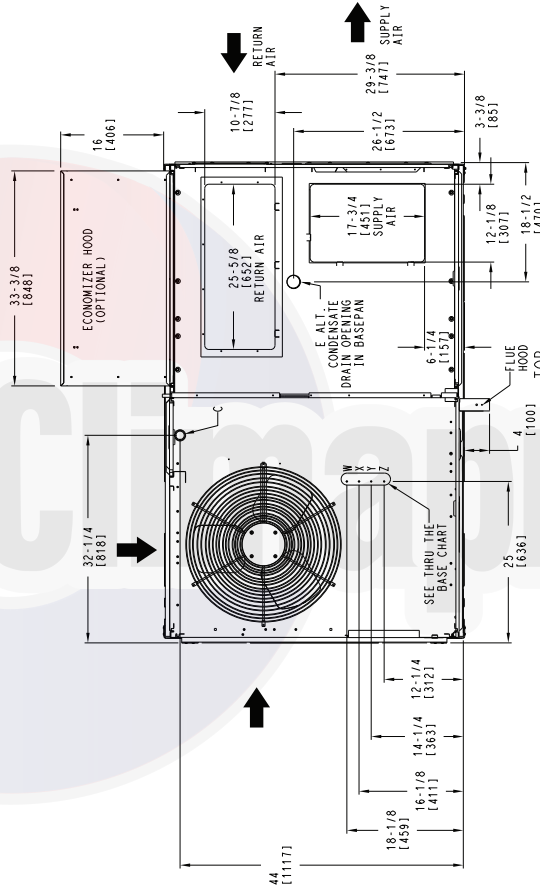

SHEET	DATE	SUPERCEDES	REV
1 OF 2	03-16-15	3-02-15	G.2

Fig. 2 — Unit Dimensional Drawing

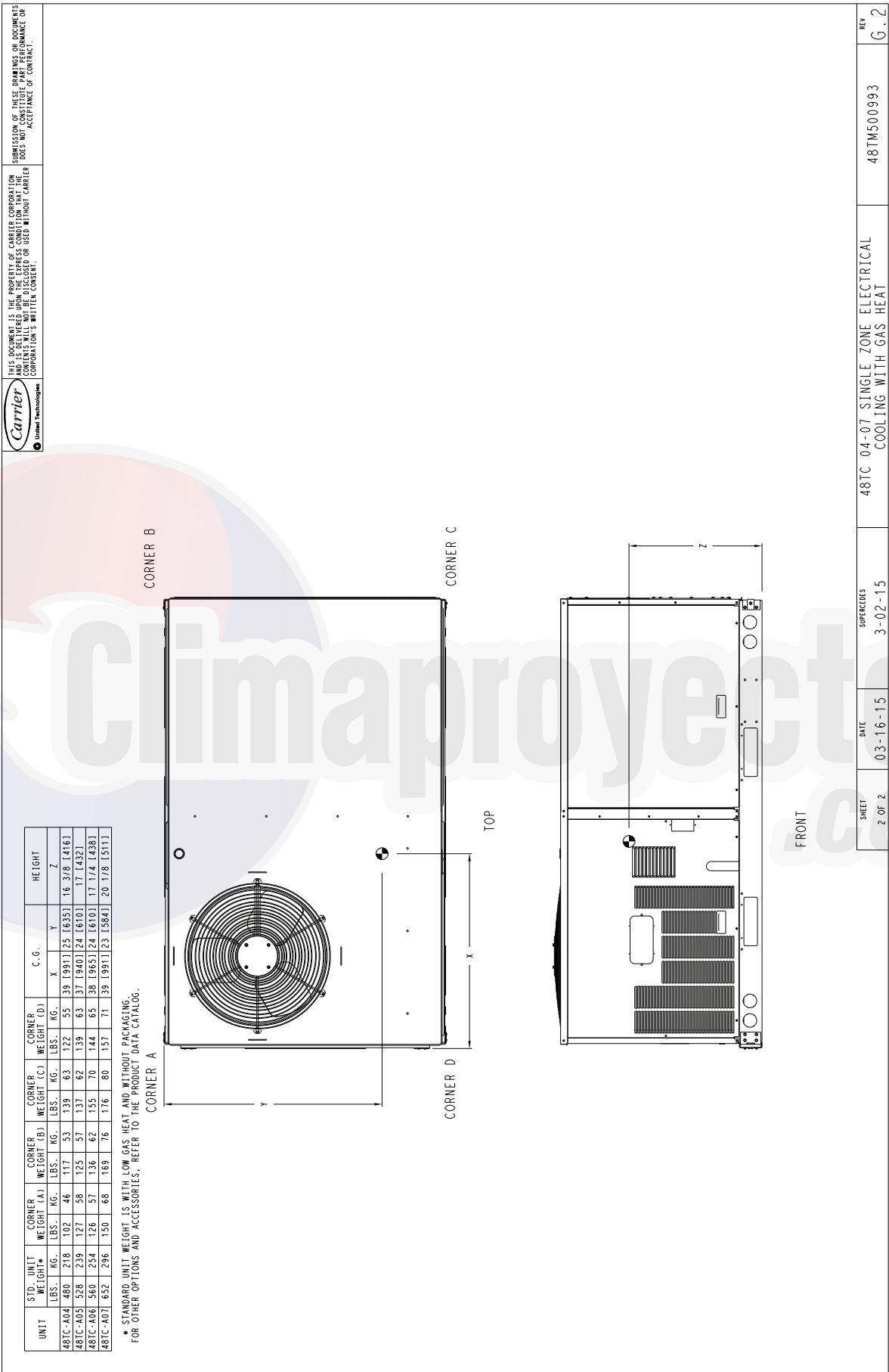
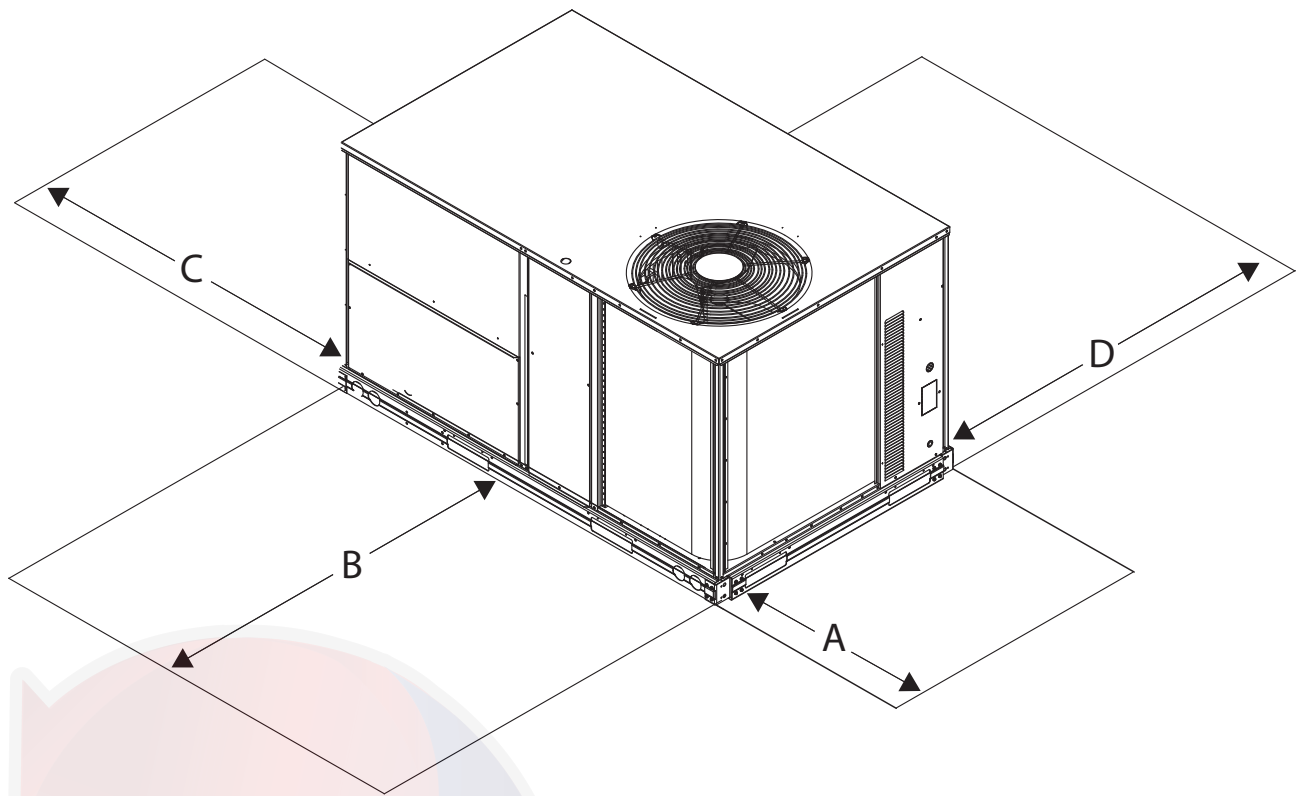

Fig. 2 — Unit Dimensional Drawing (cont)



LOCATION	DIMENSION in. (mm)	CONDITION
A	48 (1219) 18 (457) 18 (457) 12 (305)	Unit disconnect is mounted on panel. No disconnect, convenience outlet option. Recommended service clearance. Minimum clearance.
B	42 (1067) 36 (914) Special	Surface behind servicer is grounded (e.g., metal, masonry wall). Surface behind servicer is electrically non-conductive (e.g., wood, fiberglass). Check for sources of flue products within 10-ft of unit fresh air intake hood.
C	36 (914) 18 (457)	Side condensate drain is used. Minimum clearance.
D	48 (1219) 42 (1067) 36 (914) Special	No flue discharge accessory installed, surface is combustible material. Surface behind servicer is grounded (e.g., metal, masonry wall, another unit). Surface behind servicer is electrically non-conductive (e.g., wood, fiberglass). Check for adjacent units or building fresh air intakes within 10-ft (3 m) of this unit's flue outlet.

Fig. 3 — Service Clearances — 48HC04-07 Units**

NOTE: Unit is not designed to have overhead obstruction. Contact Application Engineering for guidance on any application planning overhead obstruction or for vertical clearances.

INSTALLATION

Job-Site Survey — Complete the following checks before installation.

1. Consult local building codes and the NEC (National Electrical Code) ANSI/NFPA 70 for special installation requirements.
2. Determine unit location (from project plans) or select unit location.
3. Check for possible overhead obstructions which may interfere with unit lifting or rigging.

Step 1 — Plan for Unit Location — Select a location for the unit and its support system (curb or other) that provides for the minimum clearances required for safety. This includes the clearance to combustible surfaces, unit performance and service access below, around and above unit as specified in unit drawings. See Fig. 2.

NOTE: Consider also the effect of adjacent units. Be sure that unit is installed such that snow will not block the combustion intake or flue outlet.

Unit may be installed directly on wood flooring or on class A, B, or C roof-covering material when roof curb is used.

Do not install unit in an indoor location. Do not locate air inlets near exhaust vents or other sources of contaminated air. For proper unit operation, adequate combustion and ventilation air must be provided in accordance with Section 5.3 (Air for Combustion and Ventilation) of the National Fuel Gas Code, ANSI Z223.1 (American National Standards Institute) and NFPA (National Fire Protection Association) 54 TIA-54-84-1. In Canada, installation must be in accordance with the CAN1-B149 installation codes for gas burning appliances.

Although unit is weatherproof, avoid locations that permit water from higher level runoff and overhangs to fall onto the unit.

Locate mechanical draft system flue assembly at least 4 ft (1.2 m) from any opening through which combustion products could enter the building, and at least 4 ft (1.2 m) from any adjacent building (or per local code). Locate the flue assembly at least 10 ft (3.05 m) from an adjacent unit's fresh air intake hood if within 3 ft (0.91 m) of same elevation (or per local code).

When unit is located adjacent to public walkways, flue assembly must be at least 7 ft (2.1 m) above grade.

Select a unit mounting system that provides adequate height to allow installation of condensate trap per requirements. Refer to Step 11 — Install External Condensate Trap and Line – for required trap dimensions.

ROOF MOUNT — Check building codes for weight distribution requirements. Unit operating weight is shown in Table 2.

Step 2 — Plan for Sequence of Unit Installation

The support method used for this unit will dictate different sequences for the steps of unit installation. For example, on curb-mounted units, some accessories must be installed on the unit before the unit is placed on the curb. Review the following for recommended sequences for installation steps.

CURB-MOUNTED INSTALLATION

1. Install curb
2. Install field-fabricated ductwork inside curb
3. Install accessory thru-base service connection package (affects curb and unit) (refer to accessory installation instructions for details)
4. Prepare bottom condensate drain connection to suit planned condensate line routing (refer to Step 11 for details)
5. Rig and place unit
6. Install outdoor air hood
7. Install flue hood
8. Install gas piping
9. Install condensate line trap and piping
10. Make electrical connections
11. Install other accessories

PAD-MOUNTED INSTALLATION

1. Prepare pad and unit supports
2. Check and tighten the bottom condensate drain connection plug
3. Rig and place unit
4. Convert unit to side duct connection arrangement
5. Install field-fabricated ductwork at unit duct openings
6. Install outdoor air hood
7. Install flue hood
8. Install gas piping
9. Install condensate line trap and piping
10. Make electrical connections
11. Install other accessories

FRAME-MOUNTED INSTALLATION — Frame-mounted applications generally follow the sequence for a curb installation. Adapt as required to suit specific installation plan.

Step 3 — Inspect Unit — Inspect unit for transportation damage. File any claim with transportation agency.

Confirm before installation of unit that voltage, amperage and circuit protection requirements listed on unit data plate agree with power supply provided.

Step 4 — Provide Unit Support

ROOF CURB MOUNT — Curb should be level. This is necessary for unit drain to function properly. Unit leveling tolerances are shown in Fig. 4. Refer to Accessory Roof Curb Installation Instructions for additional information as required.

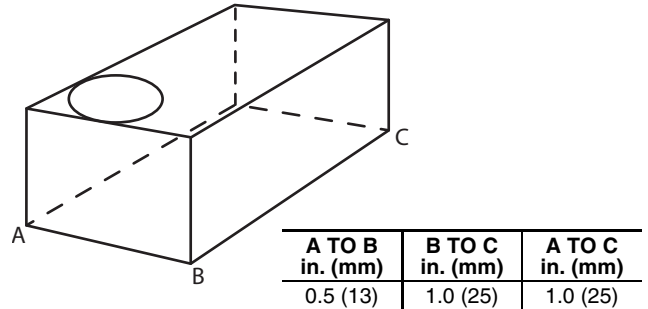

Fig. 4 — Unit Leveling Tolerances

Accessory roof curb details and dimensions are shown in Fig. 5. Assemble and install accessory roof curb in accordance with instructions shipped with the curb.

NOTE: The gasketing of the unit to the roof curb is critical for a watertight seal. Install gasket supplied with the roof curb as shown in Fig. 5. Improperly applied gasket can also result in air leaks and poor unit performance.

Install insulation, cant strips, roofing felt, and counter flashing as shown. Ductwork must be attached to curb and not to the unit. The accessory thru-the-base power and gas connection package must be installed before the unit is set on the roof curb. If field-installed thru-the-roof curb gas connections are desired, use factory-supplied 1/2-in. pipe coupling and gas plate assembly to mount the thru-the-roof curb connection to the roof curb. Gas connections and power connections to the unit must be field installed after the unit is installed on the roof curb.

If electric and control wiring is to be routed through the basepan, attach the accessory thru-the-base service connections to the basepan in accordance with the accessory installation instructions.

SLAB MOUNT (HORIZONTAL UNITS ONLY) — Provide a level concrete slab that extends a minimum of 6 in. (150 mm) beyond unit cabinet. Install a gravel apron in front of condenser coil air inlet to prevent grass and foliage from obstructing airflow.

NOTE: Horizontal units may be installed on a roof curb if required.

ALTERNATE UNIT SUPPORT (IN LIEU OF CURB OR SLAB MOUNT) — A non-combustible sleeper rail can be used in the unit curb support area. If sleeper rails cannot be used, support the long sides of the unit with a minimum of three equally spaced 4-in. x 4-in. (102 mm x 102 mm) pads on each side.

Table 2 — Operating Weights

48TC	UNITS — lb (kg)			
	A04	A05	A06	A07
Base Unit	438 (199)	494 (224)	524 (238)	607 (275)
Economizer	35 (16)	35 (16)	35 (16)	35 (16)
Humidi-MiZer® System	15 (7)	15 (7)	15 (7)	24 (7)
Cu Fins	25 (11)	43 (20)	56 (25)	73 (33)
Powered Outlet	32 (15)	32 (15)	32 (15)	32 (15)
Curb				
14-in. (356 mm)	110 (50)	110 (50)	110 (50)	110 (50)
16-in. (610 mm)	145 (66)	145 (66)	145 (66)	145 (66)

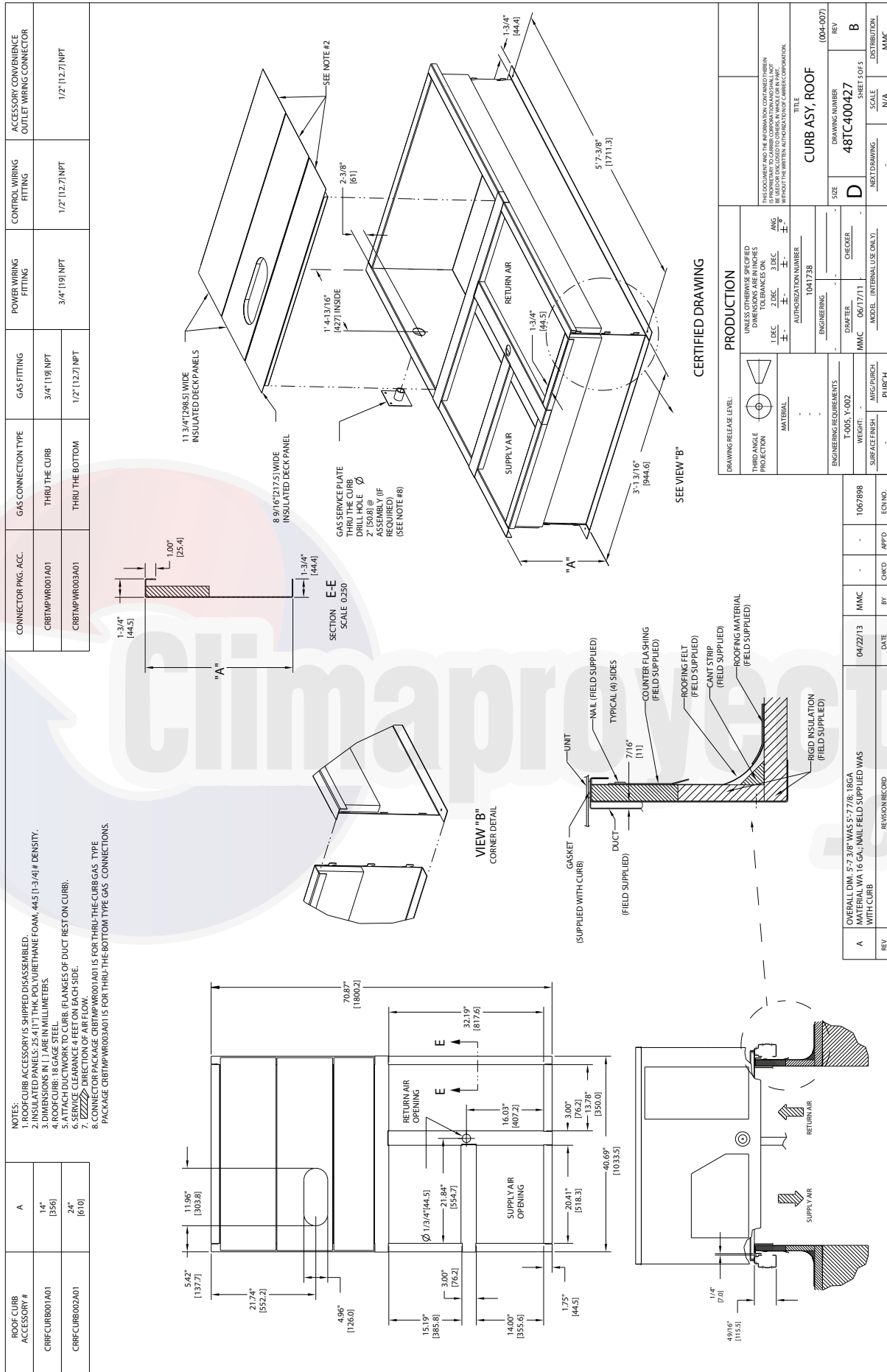

Step 5 — Field Fabricate Ductwork — Cabinet return-air static pressure (a negative condition) shall not exceed 0.35 in. wg (87 Pa) with economizer or 0.45 in. wg (112 Pa) without economizer. For vertical ducted applications, secure all ducts to roof curb and building structure. Do not connect ductwork to unit. Fabricate supply ductwork so that the cross sectional dimensions are equal to or greater than the unit supply duct opening dimensions for the first 18 in. (458 mm) of duct length from the unit basepan. Insulate and weatherproof all external ductwork, joints, and roof openings with counter flashing and mastic in accordance with applicable codes.

Ducts passing through unconditioned spaces must be insulated and covered with a vapor barrier. If a plenum return is used on a vertical unit, the return should be ducted through the roof deck to comply with applicable fire codes.

A minimum clearance is not required around ductwork.

CAUTION

Failure to follow this caution may result in damage to roofing materials.

Membrane roofs can be cut by sharp sheet metal edges. Be careful when placing any sheet metal parts on such roof.

Step 6 — Rig and Place Unit — Keep unit upright and do not drop. Spreader bars are required. Rollers may be used to move unit across a roof. Level by using unit frame as a reference. See Table 1 and Fig. 6 for additional information.

Lifting holes are provided in base rails as shown in Fig. 6. Refer to rigging instructions on unit.

Rigging materials under unit (cardboard or wood to prevent base pan damage) must be removed PRIOR to placing the unit on the roof curb. When using the standard side drain connection, ensure the red plug in the alternate bottom connection is tight. Do this before setting the unit in place. The red drain pan can be tightened with a 1/2-in. square socket drive extension.

For further details see Step 11 — Install External Condensate Trap and Line on page 14.

Before setting the unit onto the curb, recheck gasketing on curb.

CAUTION

Failure to follow this caution may result in equipment damage.

All panels must be in place when rigging. Unit is not designed for handling by fork truck.

POSITIONING ON CURB — Position unit on roof curb so that the following clearances are maintained: 1/4 in. (6.4 mm) clearance between the roof curb and the base rail inside the front and back, 0.0 in. clearance between the roof curb and the base rail inside on the duct end of the unit. This will result in the distance between the roof curb and the base rail inside on the condenser end of the unit being approximately 1/4 in. (6.4 mm).

Although unit is weatherproof, guard against water from higher level runoff and overhangs.

Flue vent discharge must have a minimum horizontal clearance of 4 ft (1220 mm) from electric and gas meters, gas regulators, and gas relief equipment. Minimum distance between unit and other electrically live parts is 48 inches (1220 mm).

Flue gas can deteriorate building materials. Orient unit such that flue gas will not affect building materials. Locate mechanical draft system flue assembly at least 48 in. (1220 mm) from an adjacent building or combustible material.

NOTE: Installation of accessory flue discharge deflector kit will reduce the minimum clearance to combustible material to 18 in. (460 mm).

After unit is in position, remove rigging skids and shipping materials.

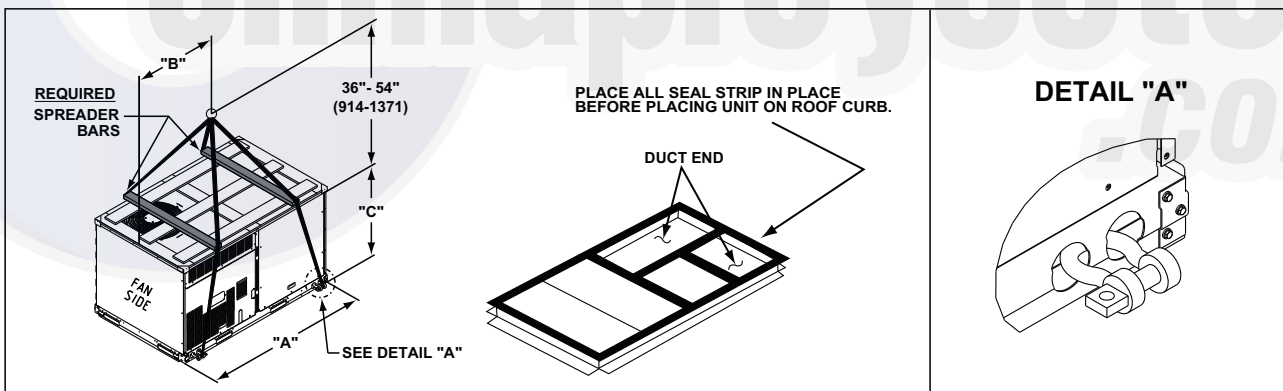

UNIT	MAX WEIGHT		DIMENSIONS					
			A		B		C	
	LB	KG	LB	KG	LB	KG	LB	KG
48TC-A04	772	350	74.5	1890	39.0	990	33.5	850
48TC-A05	826	375	74.5	1890	39.0	990	33.5	850
48TC-A06	896	406	74.5	1890	39.0	990	33.5	850
48TC-A07	1075	489	74.5	1890	39.0	990	41.5	1055

NOTES:

1. SPREADER BARS REQUIRED — Top damage will occur if spreader bars are not used.
2. Dimensions in () are in millimeters.
3. Hook rigging shackles through holes in base rail, as shown in detail "A." Holes in base rails are centered around the unit center of gravity. Use wooden top to prevent rigging straps from damaging unit.
4. Max weight includes base unit plus shipping pallet plus all available FIOPs which could be on that size unit.

→ Fig. 6 — Rigging Details

Step 7 — Convert to Horizontal and Connect Ductwork (When Required) —

Unit is shipped in the vertical duct configuration. Unit without factory-installed economizer or return air smoke detector option may be field-converted to horizontal ducted configuration. To convert to horizontal configuration, remove screws from side duct opening covers and remove covers. Using the same screws, install covers on vertical duct openings with the insulation-side down. Seals around duct openings must be tight. See Fig. 7.

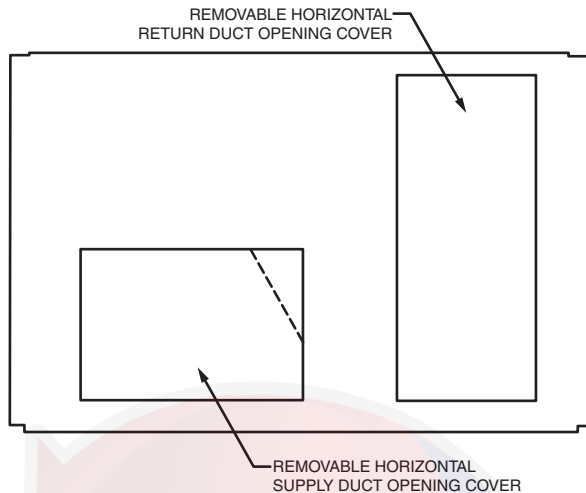

Fig. 7 — Horizontal Conversion Panels

Field-supplied flanges should be attached to horizontal duct openings and all ductwork should be secured to the flanges. Insulate and weatherproof all external ductwork, joints, and roof or building openings with counter flashing and mastic in accordance with applicable codes.

Do not cover or obscure visibility to the unit's informative data plate when insulating horizontal ductwork.

Step 8 — Install Outside Air Hood

ECONOMIZER AND TWO POSITION DAMPER HOOD PACKAGE REMOVAL AND SETUP — FACTORY OPTION

NOTE: Economizer and two position damper are not available as factory installed options for single phase (-3 voltage code) models.

1. The hood is shipped in knock-down form and must be field assembled. The indoor coil access panel is used as the hood top while the hood sides, divider and filter are packaged together, attached to a metal support tray using plastic stretch wrap, and shipped in the return air compartment behind the indoor coil access panel. The hood assembly's metal tray is attached to the basepan and also attached to the damper using two plastic tie-wraps.
2. To gain access to the hood, remove the filter access panel. See Fig. 8.

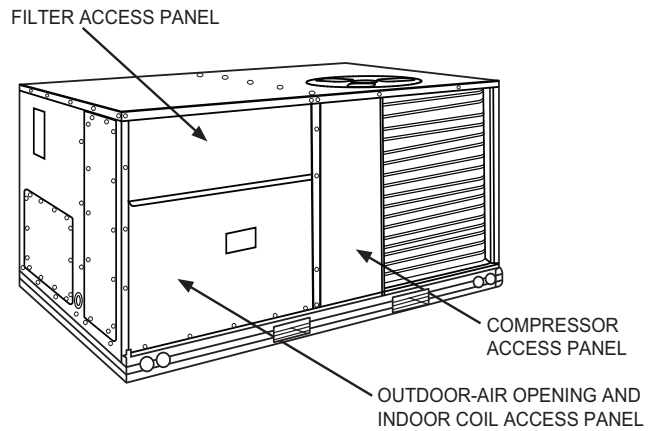

Fig. 8 — Typical Access Panel Locations

3. Locate the (2) screws holding the metal tray to the basepan and remove. Locate and cut the (2) plastic tie-wraps securing the assembly to the damper. (See Fig. 9.) Be careful to not damage any wiring or cut tie-wraps securing any wiring.

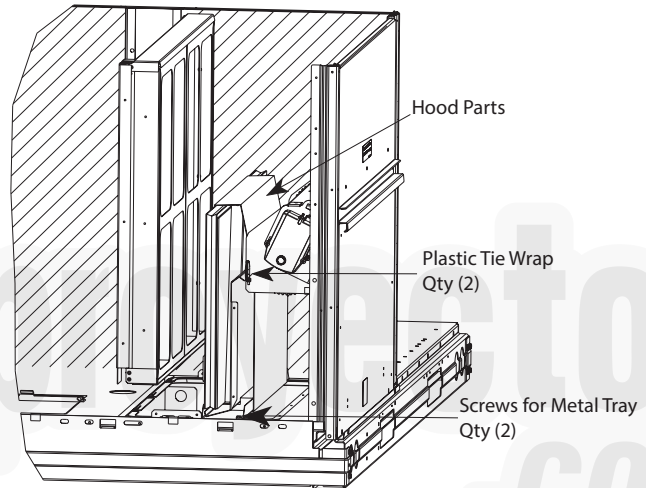

Fig. 9 — Economizer and Two-Position Damper Hood Parts Location

Carefully lift the hood assembly (with metal tray) through the filter access opening and assemble per the steps outlined in *Economizer Hood and Two-Position Hood*, below.

ECONOMIZER HOOD AND TWO-POSITION HOOD

NOTE: If the power exhaust accessory is to be installed on the unit, the hood shipped with the unit will not be used and must be discarded. Save the aluminum filter for use in the power exhaust hood assembly.

1. The indoor coil access panel will be used as the top of the hood. Remove the screws along the sides and bottom of the indoor coil access panel. See Fig. 10.

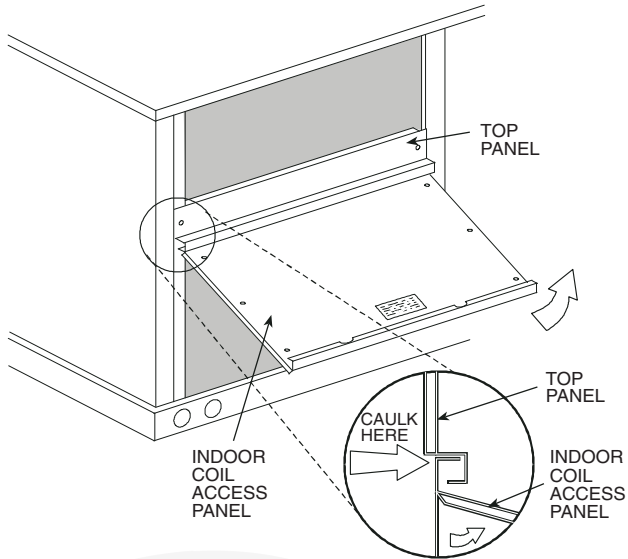

Fig. 10 — Indoor Coil Access Panel Relocation

2. Swing out indoor coil access panel and insert the hood sides under the panel (hood top). Use the screws provided to attach the hood sides to the hood top. Use screws provided to attach the hood sides to the unit. See Fig. 11.

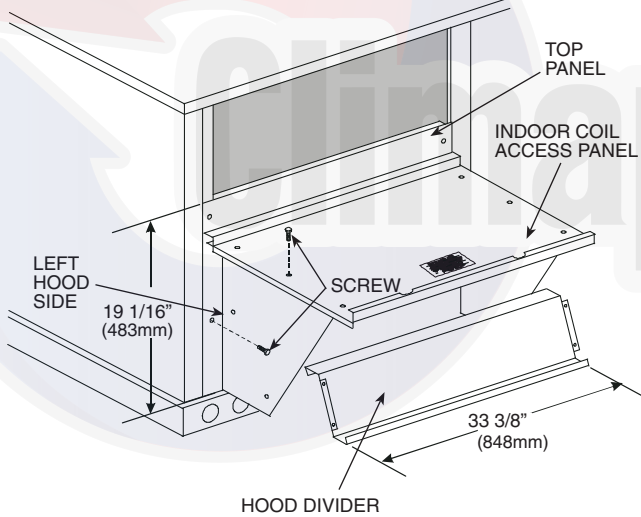

Fig. 11 — Economizer Hood Construction

3. Remove the shipping tape holding the economizer barometric relief damper in place (economizer only).
4. Insert the hood divider between the hood sides. See Fig. 11 and 12. Secure hood divider with 2 screws on each hood side. The hood divider is also used as the bottom filter rack for the aluminum filter.
5. Open the filter clips which are located underneath the hood top. Insert the aluminum filter into the bottom filter rack (hood divider). Push the filter into position past the open filter clips. Close the filter clips to lock the filter into place. See Fig. 12.
6. Caulk the ends of the joint between the unit top panel and the hood top.

7. Replace the filter access panel.

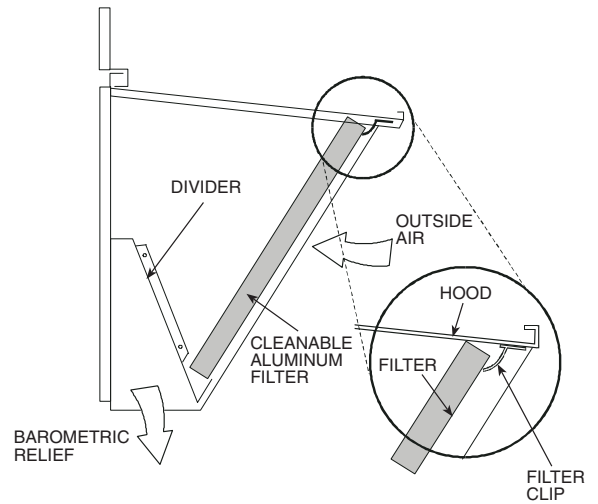

Fig. 12 — Economizer Filter Installation

Step 9 — Install Flue Hood — Flue hood is shipped screwed to the basepan beside the burner compartment access panel. Remove from shipping location and using screws provided, install flue hood and screen in location shown in Fig. 13.

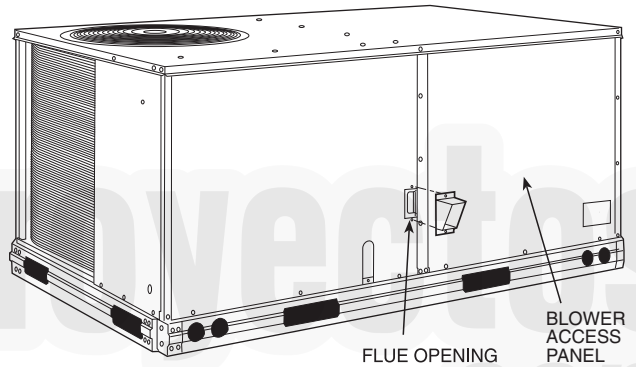

Fig. 13 — Flue Hood Details

Step 10 — Install Gas Piping — Installation of the gas piping must be accordance with local building codes and with applicable national codes. In U.S.A., refer to NFPA 54/ANSI Z223.1 National Fuel Gas Code (NFGC). In Canada, installation must be accordance with the CAN/CSA B149.1 and CAN/CSA B149.2 installation codes for gas burning appliances. This unit is factory equipped for use with Natural Gas fuel at elevations up to 2000 ft (610 m) above sea level. Unit may be field converted for operation at elevations above 2000 ft (610 m) and/or for use with liquefied petroleum fuel. See accessory kit installation instructions regarding these accessories. NOTE: Furnace gas input rate on rating plate is for installation up to 2000 ft (610 m) above sea level. In U.S.A. the input rating for altitudes above 2000 ft (610 m) must be derated by 4% for each 1000 ft (305 m) above sea level. In Canada the input rating must be derated by 10% for altitudes of 2000 ft (610 m) to 4500 ft (1372 m) above sea level.

For natural gas applications, gas pressure at unit gas connection must not be less than 4 in. wg (996 Pa) or greater than 13 in. wg (3240 Pa) while the unit is operating, see Table 3. For liquefied petroleum applications, the gas pressure must not be less than 11 in. wg (2740 Pa) or greater than 13.0 in. wg (3240 Pa) at the unit connection, see Table 4.

Table 3 — Natural Gas Supply Line Pressure Ranges

UNIT MODEL	UNIT SIZE	MIN.	MAX.
48TCD/E/F	04, 05, 06, 07	4.0 in. wg (996 Pa)	13.0 in. wg (3240 Pa)

Table 4 — Liquid Propane Supply Line Pressure Ranges

UNIT MODEL	UNIT SIZE	MIN.	MAX.
48TCD/E/F	04, 05, 06, 07	11.0 in. wg (2740 Pa)	13.0 in. wg (3240 Pa)

The gas supply pipe enters the unit at the burner access panel on the front side of the unit, through the long slot at the bottom of the access panel. The gas connection to the unit is made to the 1/2-in. FPT gas inlet port on the unit gas valve.

Manifold pressure is factory-adjusted for NG fuel use. Adjust as required to obtain best flame characteristics. See Table 5 for ranges.

Table 5 — Natural Gas Manifold Pressure Ranges

UNIT MODEL	UNIT SIZE	HIGH FIRE.	LOW FIRE
48TCD/E/F	04, 05, 06, 07	11.0 in. wg (2740 Pa)	13.0 in. wg (3240 Pa)

Manifold pressure for LP fuel use must be adjusted to specified range, see Table 6. Follow instructions in the accessory kit to make initial readjustment.

Table 6 — Liquid Propane Manifold Pressure Ranges

UNIT MODEL	UNIT SIZE	HIGH FIRE.	LOW FIRE
48TCD/E/F	04, 05, 06, 07	11.0 in. wg (2740 Pa)	13.0 in. wg (3240 Pa)

CAUTION

Failure to follow this caution may result in damage to equipment.

When connecting the gas line to the unit gas valve, the installer **MUST** use a backup wrench to prevent damage to the valve.

Install a gas supply line that runs to the unit heating section. Refer to the NFPA 54/NFPA or equivalent code for gas pipe sizing data. Do not use a pipe size smaller than 1/2-in. Size the gas supply line to allow for a maximum pressure drop of 0.5-in.wg (124 Pa) between gas regulator source and unit gas valve connection when unit is operating at high-fire flow rate.

The gas supply line can approach the unit in three ways: horizontally from outside the unit (across the roof), thru-curb/under unit basepan (accessory kit required) or through unit basepan (factory-option or accessory kit required). Consult accessory kit installation instructions for details on these installation methods. Observe clearance to gas line components per Fig. 14.

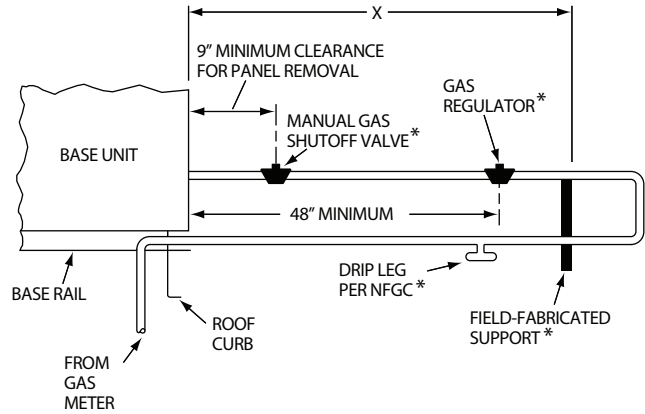

STEEL PIPE NOMINAL DIAMETER (in.)	SPACING OF SUPPORTS X DIMENSIONS (FT)
1/2	6
3/4 or 1	8
1 1/4 or larger	10

LEGEND

NFGC — National Fuel Gas Code
* Field-Supplied.

Fig. 14 — Gas Piping Guide (with Accessory Thru-the-Curb Service Connections)

FACTORY-OPTION THRU-BASE CONNECTIONS (GAS CONNECTIONS) — This service connection kit consists of a 1/2-in. NPT gas adapter fitting (brass), a 1/2-in. electrical bulkhead connector and a 3/4-in. electrical bulkhead connector, all factory-installed in the embossed (raised) section of the unit basepan in the condenser section. See Fig. 15.

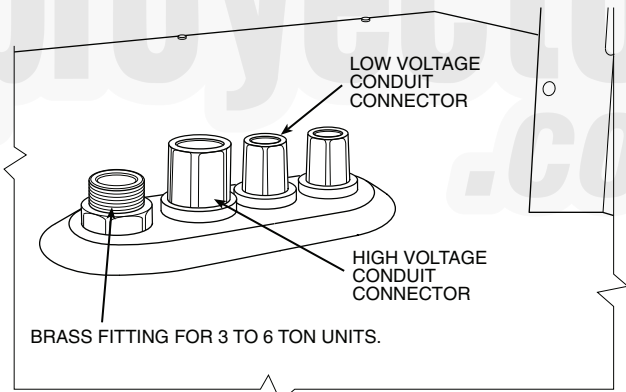

Fig. 15 — Thru-Base Connection Fittings

The thru-base gas connector has male and female threads. The male threads protrude above the basepan of the unit; the female threads protrude below the basepan.

Check tightness of connector lock nuts before connecting gas piping.

The thru-base gas connector has male and female threads. The male threads protrude above the basepan of the unit; the female threads protrude below the basepan.

Check tightness of connector lock nuts before connecting gas piping.

Install a 1/2-in. NPT street elbow on the thru-base gas fitting. Attach a 1/2-in. pipe nipple with minimum length of 16-in.

(406 mm) (field-supplied) to the street elbow and extend it through the access panel at the gas support bracket. See Fig. 16.

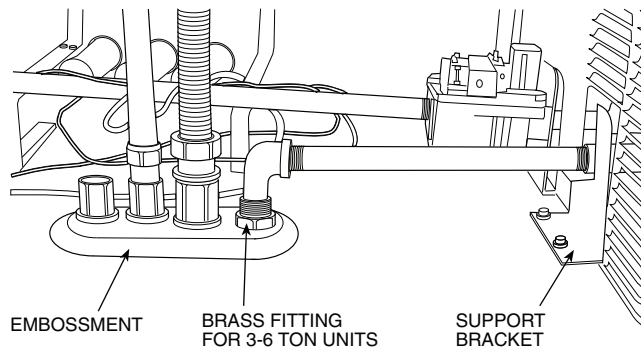

Fig. 16 — Gas Line Piping (3 to 6 Ton Units Only)

Other hardware required to complete the installation of the gas supply line will include a manual shutoff valve, a sediment trap (drip leg) and a ground-joint union. A pressure regulator valve may also be required (to convert gas pressure from pounds to inches of pressure). The manual shutoff valve must be located within 6-ft (1.83 m) of the unit. The union, located in the final leg entering the unit, must be located at least 9-in. (230 mm) away from the access panel to permit the panel to be removed for service. If a regulator valve is installed, it must be located a minimum of 4-ft (1220 mm) away from the unit's flue outlet. Some municipal codes require that the manual shut-off valve be located upstream of the sediment trap. See Fig. 17 and 18 for typical piping arrangements for gas piping that has been routed through the sidewall of the curb. See Fig. 19 for typical piping arrangement when thru-base is used. Ensure that all piping does not block access to the unit's main control box or limit the required working space in front of the control box.

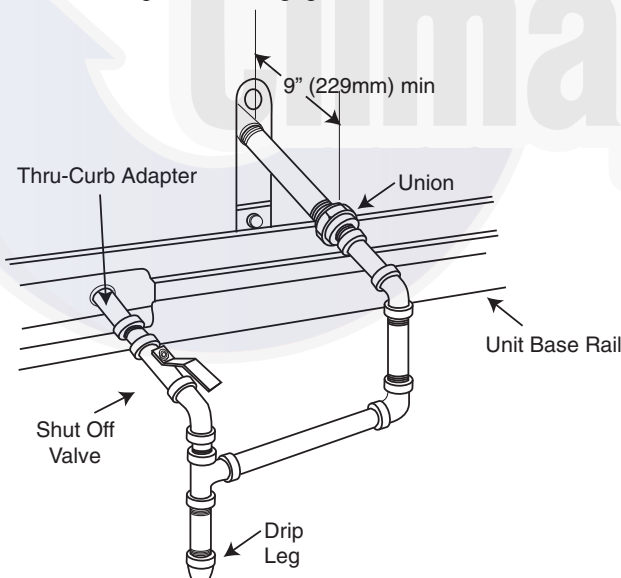

Fig. 17 — Gas Piping with Thru-Curb Accessory

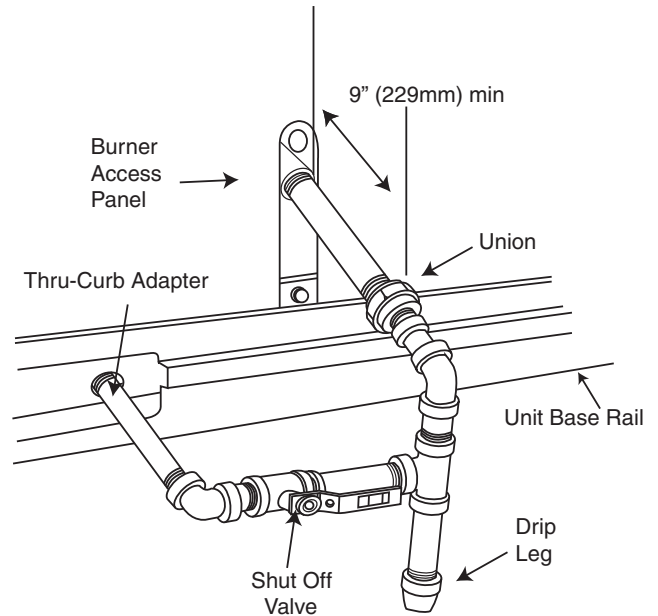

Fig. 18 — Gas Piping with Thru-Curb Accessory (Alternate Layout)

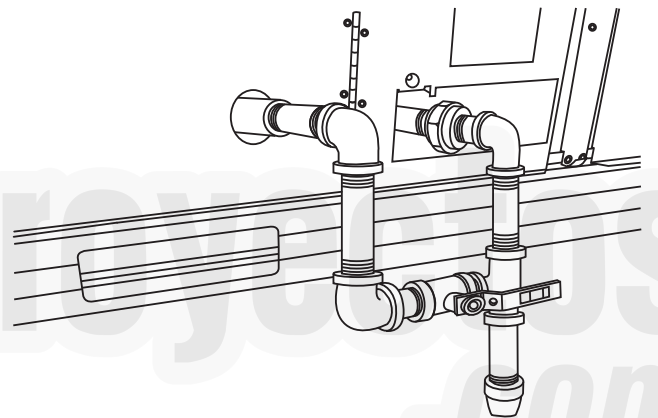

Fig. 19 — Gas Piping Thru-Base Connections

When installing the gas supply line, observe local codes pertaining to gas pipe installations. Refer to the NFPA 54/ANSI Z223.1 NFGC latest edition (in Canada, CAN/CSA B149.1). In the absence of local building codes, adhere to the following pertinent recommendations:

1. Avoid low spots in long runs of pipe. Grade all pipe 1/4-in. in every 15 ft (7 mm in every 5 m) to prevent traps. Grade all horizontal runs downward to risers. Use risers to connect to heating section and to meter.
2. Protect all segments of piping system against physical and thermal damage. Support all piping with appropriate straps, hangers, etc. Use a minimum of one hanger every 6 ft (1.8 m). For pipe sizes larger than 1/2-in., follow recommendations of national codes.
3. Apply joint compound (pipe dope) sparingly and only to male threads of joint when making pipe connections. Use only pipe dope that is resistant to action of liquefied petroleum gases as specified by local and/or national codes. If using PTFE (Teflon*) tape, ensure the material is Double Density type and is labeled for use on gas lines. Apply tape per manufacturer's instructions.
4. Pressure-test all gas piping in accordance with local and national plumbing and gas codes before connecting piping to unit.

* Teflon is a registered trademark of DuPont.

NOTE: Pressure test the gas supply system after the gas supply piping is connected to the gas valve. The supply piping must be disconnected from the gas valve during the testing of the piping systems when test pressure is in excess of 0.5 psig (3450 Pa). Pressure test the gas supply piping system at pressures equal to or less than 0.5 psig (3450 Pa). The unit heating section must be isolated from the gas piping system by closing the external main manual shutoff valve and slightly opening the ground-joint union.

Check for gas leaks at the field-installed and factory-installed gas lines after all piping connections have been completed. Use soap-and-water solution (or method specified by local codes and/or regulations).

WARNING

Failure to follow this warning could result in personal injury, death and/or property damage.

- Connect gas pipe to unit using a backup wrench to avoid damaging gas controls.
- Never purge a gas line into a combustion chamber.
- Never test for gas leaks with an open flame. Use a commercially available soap solution made specifically for the detection of leaks to check all connections.
- Use proper length of pipe to avoid stress on gas control manifold.

NOTE: If orifice hole appears damaged or it is suspected to have been re-drilled, check orifice hole with a numbered drill bit of correct size. Never re-drill an orifice. A burr-free and squarely aligned orifice hole is essential for proper flame characteristics. See Fig. 20.

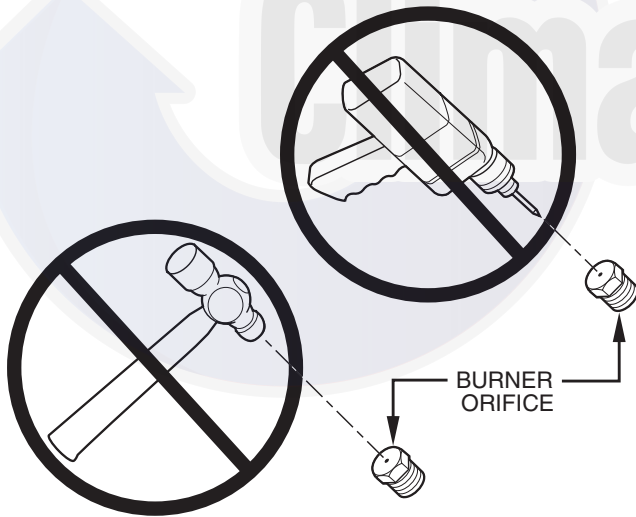

Fig. 20 — Orifice Hole

Step 11 — Install External Condensate Trap and Line

The unit has one 3/4-in. condensate drain connection on the end of the condensate pan and an alternate connection on the bottom. See Fig. 21. Unit airflow configuration does not determine which drain connection to use. Either drain connection can be used with vertical or horizontal applications.

To use the alternate bottom drain connection, remove the red drain plug from the bottom connection (use a 1/2-in. square socket drive extension) and install it in the side drain connection.

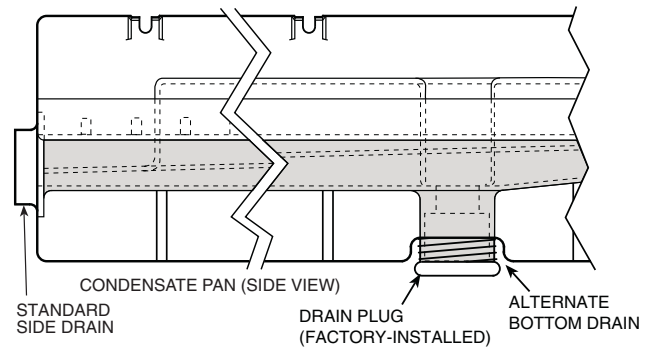

Fig. 21 — Condensate Drain Pan (Side View)

The piping for the condensate drain and external trap can be completed after the unit is in place. See Fig. 22.

NOTE: If the alternate bottom drain is not used check the drain plug for tightness prior to setting the unit on the roof curb.

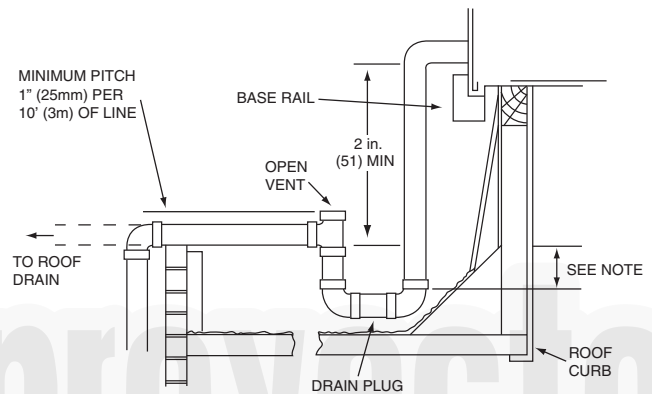

Fig. 22 — Condensate Drain Piping Details

All units must have an external trap for condensate drainage. Install a trap at least 4-in. (102 mm) deep and protect against freeze-up. If drain line is installed downstream from the external trap, pitch the line away from the unit at 1-in. per 10 ft (25 mm in 3 m) of run. Do not use a pipe size smaller than the unit connection (3/4-in.).

Step 12 — Make Electrical Connections

WARNING

Failure to follow this warning could result in personal injury or death.

Do not use gas piping as an electrical ground. Unit cabinet must have an uninterrupted, unbroken electrical ground to minimize the possibility of personal injury if an electrical fault should occur. This ground may consist of electrical wire connected to unit ground lug in control compartment, or conduit approved for electrical ground when installed in accordance with NEC (National Electrical Code); ANSI/NFPA 70, latest edition (in Canada, Canadian Electrical Code CSA [Canadian Standards Association] C22.1), and local electrical codes.

NOTE: Field-supplied wiring shall conform with the limitations of minimum 63°F (33°C) rise.

FIELD POWER SUPPLY — If equipped with optional Powered Convenience Outlet: The power source leads to the convenience outlet's transformer primary are not factory connected. Installer must connect these leads according to required operation of the convenience outlet. If an always-energized convenience outlet operation is desired, connect the source leads to the line side of the unit-mounted disconnect. (Check with local codes to ensure this method is acceptable in your area.) If a de-energize via unit disconnect switch operation of the convenience outlet is desired, connect the source leads to the load side of the unit disconnect. On a unit without a unit-mounted disconnect, connect the source leads to compressor contactor C and indoor fan contactor IFC pressure lugs with unit field power leads.

Refer to Fig. 23 for power transformer connections and the discussion on connecting the convenience outlet on page 18.

Field power wires are connected to the unit at line-side pressure lugs on compressor contactor C and indoor fan contactor IFC (see wiring diagram label for control box component arrangement) or at factory-installed option non-fused disconnect switch. Max wire size is #2 AWG (copper only). (See Fig. 23.)

NOTE: TEST LEADS - Unit may be equipped with short leads (pigtails) on the field line connection points on contactor C or optional disconnect switch. These leads are for factory run-test purposes only; remove and discard before connecting field power wires to unit connection points. Make field power connections directly to line connection pressure lugs only.

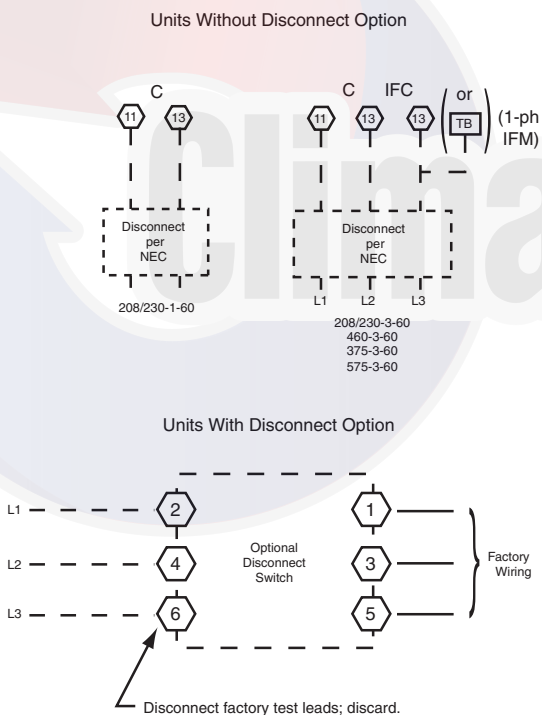

Fig. 23 — Power Wiring Connections

WARNING

Failure to follow this warning could result in intermittent operation or performance satisfaction.

Do not connect aluminum wire between disconnect switch and 48TC unit. Use only copper wire. (See Fig. 24.)

UNITS WITH FACTORY-INSTALLED NON-FUSED DISCONNECT — The factory-installed option non-fused disconnect (NFD) switch is located in a weatherproof enclosure located under the main control box. The manual switch handle and shaft are shipped in the disconnect enclosure.

Assemble the shaft and handle to the switch at this point. Discard the factory test leads (see Fig. 24).

Connect field power supply conductors to LINE side terminals when the switch enclosure cover is removed to attach the handle.

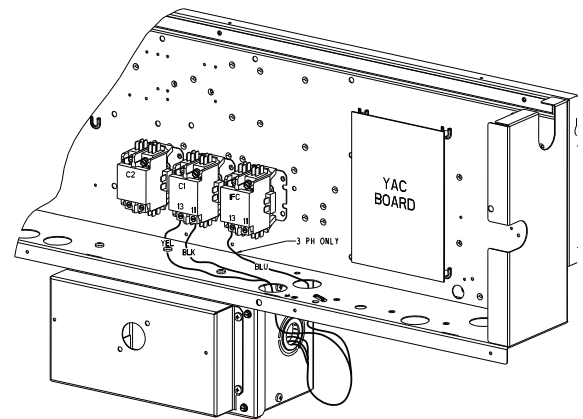

Fig. 24 — Location of Non-Fused Disconnect Enclosure

To field install the NFD shaft and handle

1. Remove the unit front pane (see Fig. 2).
2. Remove (3) hex screws on the NFD enclosure - (2) on the face of the cover and (1) on the left side cover (see Fig. 25).
3. Remove the front cover of the NFD enclosure.
4. Make sure the NFD shipped from the factory is at OFF position (the arrow on the black handle knob is at OFF).
5. Insert the shaft with the cross pin on the top of the shaft in the horizontal position.
6. Measure from the tip of the shaft to the top surface of the black pointer; the measurement should be 3.75 to 3.88 in. (95 to 99 mm).
7. Tighten the locking screw to secure the shaft to the NFD.
8. Turn the handle to the OFF position with red arrow pointing at OFF.
9. Install the handle on to the painted cover horizontally with the red arrow pointing to the left.
10. Secure the handle to the painted cover with (2) screws and lock washers supplied.
11. Engaging the shaft into the handle socket, re-install (3) hex screws on the NFD enclosure.
12. Re-install the unit front panel.

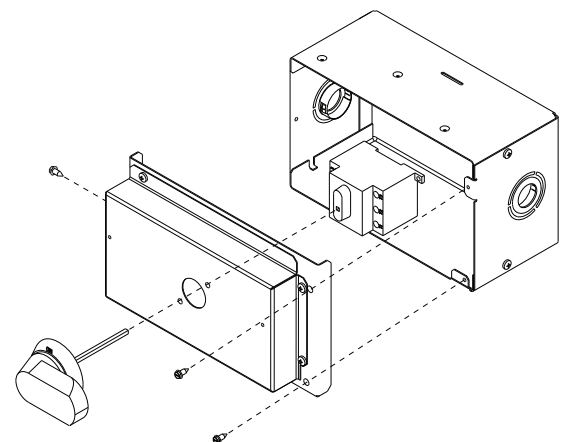

Fig. 25 — Handle and Shaft Assembly for NFD

UNITS WITHOUT FACTORY-INSTALLED NON-FUSED DISCONNECT — When installing units, provide a disconnect switch per NEC (National Electrical Code) of adequate size. Disconnect sizing data is provided on the unit informative plate. Locate on unit cabinet or within sight of the unit per national or local codes. Do not cover unit informative plate if mounting the disconnect on the unit cabinet.

All Units — Field wiring must comply with NEC and all local codes. Size wire based on MCA (Minimum Circuit Amps) on the unit informative plate. See Fig. 23 and the unit label diagram for power wiring connections to the unit power terminal blocks and equipment ground. Maximum wire size is #4 ga AWG per pole.

Provide a ground-fault and short-circuit over-current protection device (fuse or breaker) per NEC Article 440 (or local codes). Refer to unit informative data plate for MOCP (Maximum Over-current Protection) device size.

All units except 208/230-v units are factory wired for the voltage shown on the nameplate. If the 208/230-v unit is to be connected to a 208-v power supply, the control transformer must be rewired by moving the black wire with the 1/4-in. female spade connector from the 230-v connection and moving it to the 200-v 1/4-in. male terminal on the primary side of the transformer. Refer to unit label diagram for additional information.

Voltage to compressor terminals during operation must be within voltage range indicated on unit nameplate. See Tables 7 and 8. On 3-phase units, voltages between phases must be balanced within 2% and the current within 10%. Use the formula shown in the legend for Tables 7 and 8 to determine the percent of voltage imbalance. Operation on improper line voltage or excessive phase imbalance constitutes abuse and may cause damage to electrical components. Such operation would invalidate any applicable Carrier warranty.

NOTE: Check all factory and field electrical connections for tightness.

Table 7 — Unit Wire/Fuse or HACR Breaker Sizing Data — 2-Speed Indoor Fan Motor

UNIT	NOM. V-PH-HZ	IFM TYPE	NO C.O. OR UNPWR C.O.								WITH PWRD C.O.							
			NO P.E.				WITH P.E. (POWERED FROM UNIT)				NO P.E.				WITH P.E. (POWERED FROM UNIT)			
			MCA	FUSE OR HACR BRKR	FLA	LRA	MCA	FUSE OR HACR BRKR	FLA	LRA	MCA	FUSE OR HACR BRKR	FLA	LRA	MCA	FUSE OR HACR BRKR	FLA	LRA
48TC*A07	208/230-3-60	STD	34/33	50/50	32/32	167	35/35	50/50	35/34	169	38/38	50/50	38/38	172	40/40	50/50	40/40	174
		MED	35/34	50/50	34/33	193	37/36	50/50	36/35	195	40/39	50/50	40/39	198	42/41	60/60	42/41	200
		HIGH	37/36	50/50	37/36	217	39/38	50/50	39/38	219	42/41	60/60	42/41	222	44/43	60/60	44/43	224
	460-3-60	STD	15	20	14	82	16	20	15	83	17	20	17	84	18	25	18	85
		MED	15	20	15	95	16	20	16	96	18	25	17	97	19	25	18	98
		HIGH	16	20	16	107	17	25	17	108	19	25	19	109	20	25	20	110
	575-3-60	STD	13	15	12	70	15	20	14	72	15	20	14	72	16	20	16	74
		MED	14	15	13	79	16	20	16	81	16	20	15	81	17	20	18	83
		HIGH	14	15	13	79	16	20	16	81	16	20	15	81	17	20	18	83

LEGEND AND NOTES FOR TABLES 7 AND 8

LEGEND

- BRKR** — Circuit breaker
- C.O.** — Convenience outlet
- DD** — Direct drive
- DISC** — Disconnect
- FLA** — Full load amps
- IFM** — Indoor fan motor
- LRA** — Locked rotor amps
- MCA** — Minimum circuit amps
- MOCP** — MAX FUSE or HACR circuit breaker
- P.E.** — Power exhaust
- PWRD C.O.** — Powered convenience outlet
- UNPWR C.O.** — Unpowered convenience outlet

1. In compliance with NEC requirements for multimotor and combination load equipment (refer to NEC Articles 430 and 440), the overcurrent protective device for the unit shall be fuse or HACR breaker. Canadian units may be fuse or circuit breaker.

2. Unbalanced 3-Phase Supply Voltage:

Never operate a motor where a phase imbalance in supply voltage is greater than 2%. Use the following formula to determine the percentage of voltage imbalance:

$$\% \text{ Voltage Imbalance} = 100 \times \frac{\text{max voltage deviation from average voltage}}{\text{average voltage}}$$

Example: Supply voltage is 230-3-60



AB = 224 v
BC = 231 v
AC = 226 v

$$\text{Average Voltage} = 100 \times \frac{(224 + 231 + 226)}{3} = \frac{681}{3} = 227$$

Determine maximum deviation from average voltage.

(AB) 227-224 = 3 v

(BC) 231-227 = 4 v

(AC) 227-226 = 1 v

Maximum deviation is 4 v.

Determine percent of voltage imbalance.

$$\% \text{ Voltage Imbalance} = 100 \times \frac{4}{227} = 1.76\%$$

This amount of phase imbalance is satisfactory as it is below the maximum allowable 2%.

IMPORTANT: If the supply voltage phase imbalance is more than 2%, contact your local electric utility company immediately.

Table 8 — Unit Wire/Fuse or HACR Breaker Sizing Data — Single Speed Indoor Fan Motor

UNIT	NOM. V-PH-HZ	IFM TYPE	NO C.O. OR UNPWR C.O.								WITH PWRD C.O.							
			NO P.E.				WITH P.E. (POWERED FROM UNIT)				NO P.E.				WITH P.E. (POWERED FROM UNIT)			
			MCA	FUSE OR HACR BRKR	DISC. SIZE		MCA	FUSE OR HACR BRKR	DISC. SIZE		MCA	FUSE OR HACR BRKR	DISC. SIZE		MCA	FUSE OR HACR BRKR	DISC. SIZE	
					FLA	LRA			FLA	LRA			FLA	LRA			FLA	LRA
48TC**04	208/230-1-60	STD	28	40	26	95	30	45	29	97	32	45	32	100	34	50	34	102
		MED	28	40	26	95	30	45	29	97	32	45	32	100	34	50	34	102
	208/230-3-60	DD-STD	21	30	21	83	23	30	23	85	26	30	26	88	28	30	28	90
		STD	20	30	20	96	22	30	22	98	25	30	25	101	27	30	27	103
		MED	20	30	20	96	22	30	22	98	25	30	25	101	27	30	27	103
	460-3-60	HIGH	20	30	20	107	22	30	22	109	25	30	25	112	27	30	27	114
		STD	11	15	11	49	12	15	12	50	13	15	13	51	14	20	14	52
		MED	11	15	11	49	12	15	12	50	13	15	13	51	14	20	14	52
	575-3-60	HIGH	11	15	11	55	12	15	12	56	13	15	13	57	14	20	14	58
		STD	8	15	8	46	10	15	10	48	10	15	10	48	12	15	12	50
		MED	8	15	8	46	10	15	10	48	10	15	10	48	12	15	12	50
	48TC**05	208/230-1-60	STD	34	50	32	133	36	50	35	135	39	60	38	138	41	60	40
MED			34	50	32	133	36	50	35	135	39	60	38	138	41	60	40	140
208/230-3-60		DD-STD	25	30	24	93	27	30	27	95	30	40	30	98	32	45	32	100
		STD	24	30	23	106	26	30	26	108	29	40	29	111	31	40	31	113
		MED	24	30	23	106	26	30	26	108	29	40	29	111	31	40	31	113
460-3-60		HIGH	24	30	23	117	26	30	26	119	29	40	29	122	31	40	31	124
		STD	12	15	11	52	13	15	12	53	14	15	14	54	15	20	15	55
		MED	12	15	11	52	13	15	12	53	14	15	14	54	15	20	15	55
575-3-60		HIGH	12	15	11	58	13	15	12	59	14	15	14	60	15	20	15	61
		STD	9	15	9	42	11	15	11	44	11	15	11	44	13	15	13	46
		MED	9	15	9	42	11	15	11	44	11	15	11	44	13	15	13	46
48TC**06		208/230-1-60	STD	40	60	37	150	42	60	40	152	44	60	43	155	46	60	45
	MED		42	60	40	175	44	60	42	177	47	60	45	180	48	60	48	182
	208/230-3-60	DD-STD	29	40	28	122	31	45	31	124	34	45	34	127	36	50	36	129
		STD	27	40	26	133	29	40	28	135	31	45	31	138	33	45	33	140
		MED	27	40	26	133	29	40	28	135	31	45	31	138	33	45	33	140
	460-3-60	HIGH	29	40	28	170	31	45	30	172	34	45	34	175	36	50	36	177
		STD	13	20	13	63	14	20	14	64	16	20	15	65	17	20	16	66
		MED	13	20	13	63	14	20	14	64	16	20	15	65	17	20	16	66
	575-3-60	HIGH	14	20	14	82	15	20	15	83	16	20	16	84	17	20	17	85
		STD	11	15	10	48	13	15	12	50	12	15	12	50	14	20	14	52
		MED	11	15	10	48	13	15	12	50	12	15	12	50	14	20	14	52
	48TC**07	208/230-3-60	HIGH	11	15	11	63	13	15	13	65	13	15	13	65	15	20	15
STD			32	50	30	170	34	50	32	172	36	50	36	175	38	50	38	177
MED			35/35	50/50	34/34	212	37/37	50/50	36/36	214	40/40	50/50	39/39	217	42/41	60/60	42/42	219
460-3-60		HIGH	37	50	36	226	39	50	39	228	42	60	42	231	44	60	44	233
		STD	14	20	13	83	15	20	14	84	16	20	16	85	17	25	17	86
		MED	16	20	15	104	17	20	16	105	18	25	18	106	19	25	19	107
575-3-60		HIGH	17	20	16	111	18	25	18	112	19	25	19	113	20	25	20	114
		STD	11	15	11	68	13	15	13	70	13	15	13	70	15	20	15	72
		MED	12	15	12	79	14	20	14	81	14	15	13	81	16	20	16	83
575-3-60		HIGH	12	15	12	79	14	20	14	81	14	15	13	81	16	20	16	83

CONVENIENCE OUTLETS

WARNING

Failure to follow this warning could result in personal injury or death.

Units with convenience outlet circuits may use multiple disconnects. Check convenience outlet for power status before opening unit for service. Locate its disconnect switch, if appropriate, and open it. Lock-out and tag-out this switch, if necessary.

Two types of convenience outlets are offered on 48TC models: Non-powered and unit-powered. Both types provide a 125-volt GFCI (ground-fault circuit-interrupter) duplex receptacle rated at 15-A behind a hinged waterproof access cover, located on the end panel of the unit. See Fig. 26 for amp limitations. See Fig. 27 for convenience outlet location.

NOTICE

Convenience Outlet Utilization

Maximum Continuous use: 15 Amps for receptacle outlets, and 8 Amps for factory supplied transformers

50HJ542739 C

Fig. 26 — Convenience Outlet Utilization Notice Label

NOTE: Unit powered convenience outlets are not available as factory installed options for single phase (-3 voltage code) models.

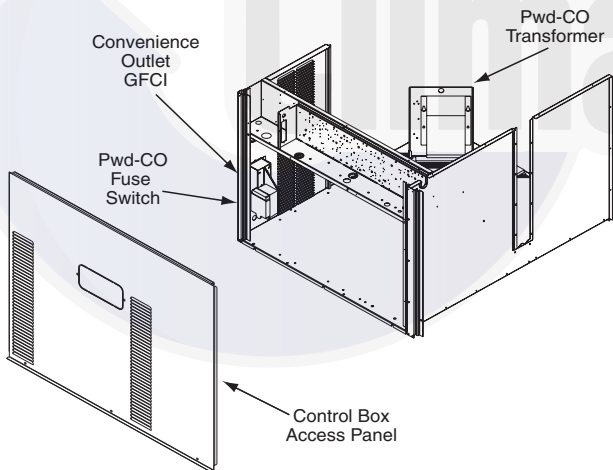

Fig. 27 — Convenience Outlet Location

Installing Weatherproof Cover — is now required by UL standards for the factory-installed convenience outlets. This cover cannot be factory-mounted due its depth; it must be installed at unit installation. For shipment, the convenience outlet is covered with a blank cover plate.

On units with electro-mechanical controls the weatherproof cover kit is shipped in the unit's control box. The kit includes the hinged cover, a backing plate and gasket. On units with a factory installed direct digital controller (PremierLink™ or

RTU Open) the weatherproof cover kit is secured to the base-pan underneath the control box, see Fig. 28.

IMPORTANT: DISCONNECT ALL POWER TO UNIT AND CONVENIENCE OUTLET. LOCK-OUT AND TAG-OUT ALL POWER PRIOR TO INSTALLATION.

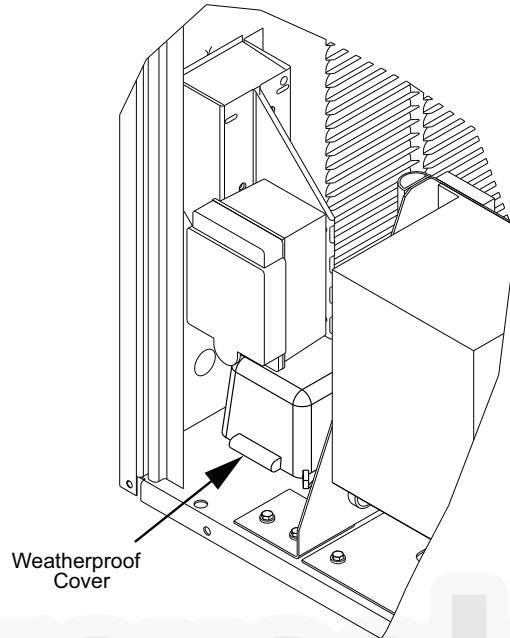

Fig. 28 — Weatherproof Cover — Shipping Location on Units with Factory Installed DDC

Remove the blank cover plate at the convenience outlet.

Loosen the two screws at the GFCI duplex outlet, until approximately 1/2-in. (13 mm) under screw heads are exposed. Press the gasket over the screw heads. Slip the backing plate over the screw heads at the keyhole slots and align with the gasket; tighten the two screws until snug (do not over-tighten).

Mount the weatherproof cover to the backing plate as shown in Fig. 29. Remove two slot fillers in the bottom of the cover to permit service tool cords to exit the cover. Check for full closing and latching.

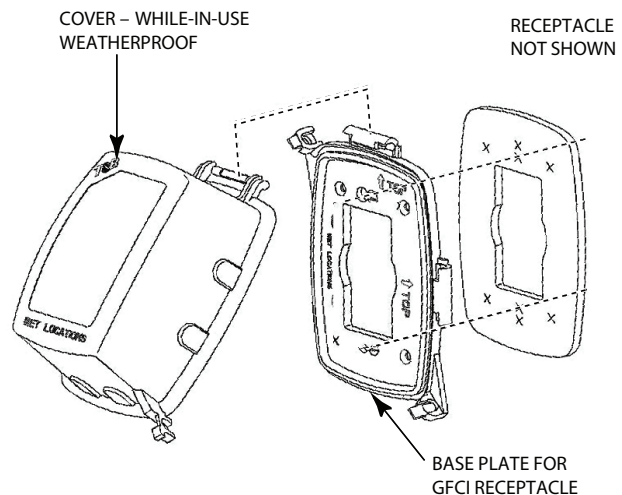

Fig. 29 — Weatherproof Cover Installation

Non-powered type — Requires the field installation of a general-purpose 125-volt 15-A circuit powered from a source elsewhere in the building. Observe national and local codes when

selecting wire size, fuse or breaker requirements and disconnect switch size and location. Route 125-v power supply conductors into the bottom of the utility box containing the duplex receptacle.

Unit-powered type — A unit-mounted transformer which is factory-installed to step-down the main power supply voltage to the unit to 115-v at the duplex receptacle. This option also includes a manual switch with fuse, located in a utility box and mounted on a bracket behind the convenience outlet; access is through the unit's control box access panel. See Fig. 27.

The primary leads to the convenience outlet transformer are not factory-connected. Selection of primary power source is a customer-option. If local codes permit, the transformer primary leads can be connected at the line-side terminals on the unit-mounted non-fused disconnect or HACR breaker switch; this will provide service power to the unit when the unit disconnect switch or HACR switch is open. Other connection methods will result in the convenience outlet circuit being de-energized when the unit disconnect or HACR switch is open. See Fig. 30.

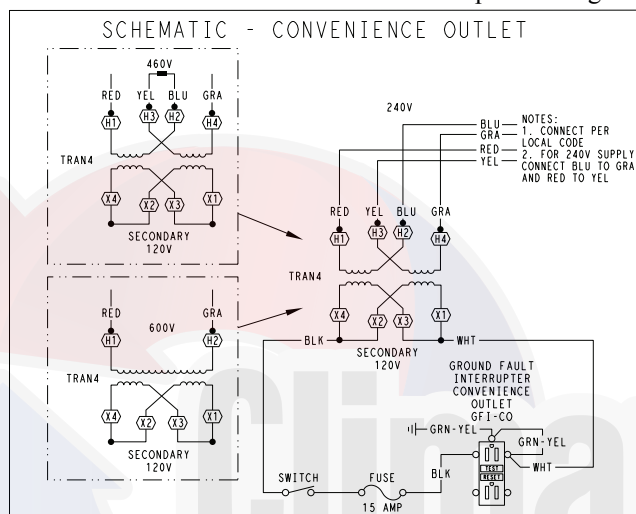

UNIT VOLTAGE	CONNECT AS	PRIMARY CONNECTIONS	TRANSFORMER TERMINALS
208, 230	240	L1: RED+YEL L2: BLU+YEL	H1+H3 H2+H4
460	480	L1: RED L2: Splice BLU+YEL L3: GRA	H1 H2+H3 H4
575	600	L1: RED L2: GRA	H1 H2

Fig. 30 — Powered Convenience Outlet Wiring

Test the GFCI receptacle by pressing the TEST button on the face of the receptacle to trip and open the receptacle. Check for proper grounding wires and power line phasing if the GFCI receptacle does not trip as required. Press the RESET button to clear the tripped condition.

Fuse on power type — The factory fuse is a Bussman “Fusetron”[®] T-15, non-renewable screw-in (Edison base) type plug fuse.

Test the GFCI receptacle by pressing the TEST button on the face of the receptacle to trip and open the receptacle. Check for proper grounding wires and power line phasing if the GFCI receptacle does not trip as required. Press the RESET button to clear the tripped condition.

Using unit-mounted convenience outlets: Units with unit-mounted convenience outlet circuits will often require that two disconnects be opened to de-energize all power to the unit. Treat all units as electrically energized until the convenience

outlet power is also checked and de-energization is confirmed. Observe National Electrical Code Article 210, Branch Circuits, for use of convenience outlets.

FACTORY-OPTION THRU-BASE CONNECTIONS (ELECTRICAL CONNECTIONS) — This service connection kit consists of a 1/2-in. electrical bulkhead connector and a 1 1/4-in. electrical bulkhead connector, all factory-installed in the embossed (raised) section of the unit basepan in the condenser section. The 1/2-in. bulkhead connector enables the low-voltage control wires to pass through the basepan. The 1 1/4-in. electrical bulkhead connector allows the high-voltage power wires to pass through the basepan. See Fig. 31.

Check tightness of connector lock nuts before connecting electrical conduits.

Field-supplied and field-installed liquid tight conduit connectors and conduit may be attached to the connectors on the basepan. Pull correctly rated high voltage and low voltage through appropriate conduits. Connect the power conduit to the internal disconnect (if unit is so equipped) or to the external disconnect (through unit side panel). A hole must be field cut in the main control box bottom on the left side so the 24-v control connections can be made. Connect the control power conduit to the unit control box at this hole.

Units Without Thru-Base Connections

1. Install power wiring conduit through side panel openings. Install conduit between disconnect and control box.
2. Install power lines to terminal connections as shown in Fig. 23.

Voltage to compressor terminals during operation must be within voltage range indicated on unit nameplate. See Table 7 and 8. On 3-phase units, voltages between phases must be balanced within 2% and the current within 10%. Use the formula shown in the legend for Tables 7 and 8 to determine the percent of voltage imbalance. Operation on improper line voltage or excessive phase imbalance constitutes abuse and may cause damage to electrical components. Such operation would invalidate any applicable Carrier warranty.

Field Control Wiring — The 48TC unit requires an external temperature control device. This device can be a thermostat (field-supplied) or a PremierLink controller (available as factory-installed option or as field-installed accessory, for use on a Carrier Comfort Network[®] or as a stand alone control) or the RTU Open Controller for Building Management Systems using non-CCN protocols (RTU Open is available as a factory-installed option only).

Thermostat — Install a Carrier-approved accessory 2-stage thermostat according to installation instructions included with the accessory. Locate the thermostat accessory on a solid wall in the conditioned space to sense average temperature in accordance with the thermostat installation instructions. If the thermostat contains a logic circuit requiring 24-v power, use a thermostat cable or equivalent single leads of different colors with minimum of seven leads. If the thermostat does not require a 24-v source (no “C” connection required), use a thermostat cable or equivalent with minimum of six leads. Check the thermostat installation instructions for additional features which might require additional conductors in the cable. For wire runs up to 50 ft (15 m), use no. 18 AWG (American Wire Gage) insulated wire [35 C (95 F) minimum]. For 50 to 75 ft (15 to 23 m), use no. 16 AWG insulated wire [35 C (95 F) minimum]. For over 75 ft (23 m), use no. 14 AWG insulated wire [35 C (95 F) minimum]. All wire sizes larger than no. 18 AWG cannot be directly connected to the thermostat and will require a junction box and splice at the thermostat.

* Bussmann and Fusetron are trademarks of Cooper Technologies Company.

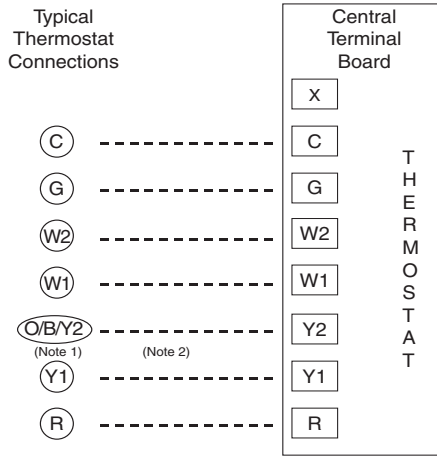

NOTES:
 1. Typical multi-function marking. Follow manufacturer's configuration instructions to select Y2. Do not configure for O output.
 2. Y2 to Y2 connection required on single-stage cooling units when integrated economizer function is desired.
 --- Field-Wiring

Fig. 31 — Low-Voltage Connections

Unit Without Thru-Base Connection Kit — Pass the thermostat control wires through the hole provided in the corner post; then feed the wires through the raceway built into the corner post to the control box. Pull the wires over to the terminal strip on the upper-left corner of the Controls Connection Board. See Fig. 32.

NOTE: If thru-the-bottom connections accessory is used, refer to the accessory installation instructions for information on routing power and control wiring.

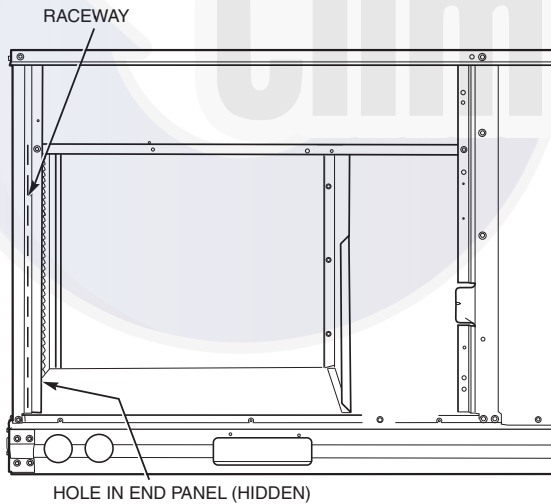

Fig. 32 — Field Control Wiring Raceway

Heat Anticipator Settings — Set heat anticipator settings at 0.14 amp for the first stage and 0.14 amp for second-stage heating, when available.

HUMIDI-MIZER® CONTROL CONNECTIONS

Humidi-MiZer – Space RH Controller

NOTE: The Humidi-MiZer is a factory installed option which is available for 07 models only.

The Humidi-MiZer dehumidification system requires a field-supplied and installed space relative humidity control device. This device may be a separate humidistat control (contact closes on rise in space RH above control setpoint) or a combination thermostat-humidistat control device such as Carrier's EDGE® Pro Thermidistat with isolated contact set for dehumidification control. The humidistat is normally used in applications where a temperature control is already provided (units with PremierLink™ control).

To Connect the Carrier Humidistat (HL38MG029) (See Fig. 33)

1. Route the humidistat 2-conductor cable (field-supplied) through the hole provided in the unit corner post.
2. Feed wires through the raceway built into the corner post (see Fig. 32) to the 24-v barrier located on the left side of the control box. The raceway provides the UL-required clearance between high-voltage and low-voltage wiring.
3. Use wire nuts to connect humidistat cable to two PINK leads in the low-voltage wiring as shown in Fig. 34.

To connect the Thermidistat device (33CS2PPRH-01) (See Fig. 35)

1. Route the Thermidistat multi-conductor thermostat cable (field-supplied) through the hole provided in the unit corner post.
2. Feed wires through the raceway built into the corner post (see Fig. 32) to the 24-v barrier located on the left side of the control box. The raceway provides the UL-required clearance between high-voltage and low-voltage wiring.
3. The Thermidistat has dry contacts at terminals D1 and D2 for dehumidification operation (see Fig. 36). The dry contacts must be wired between CTB terminal R and the PINK lead to the LTLO switch with field-supplied wire nuts. Refer to PremierLink Installation, Start-up, and Configuration Instructions for more information.

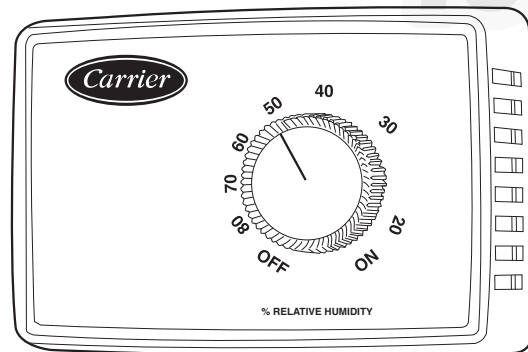
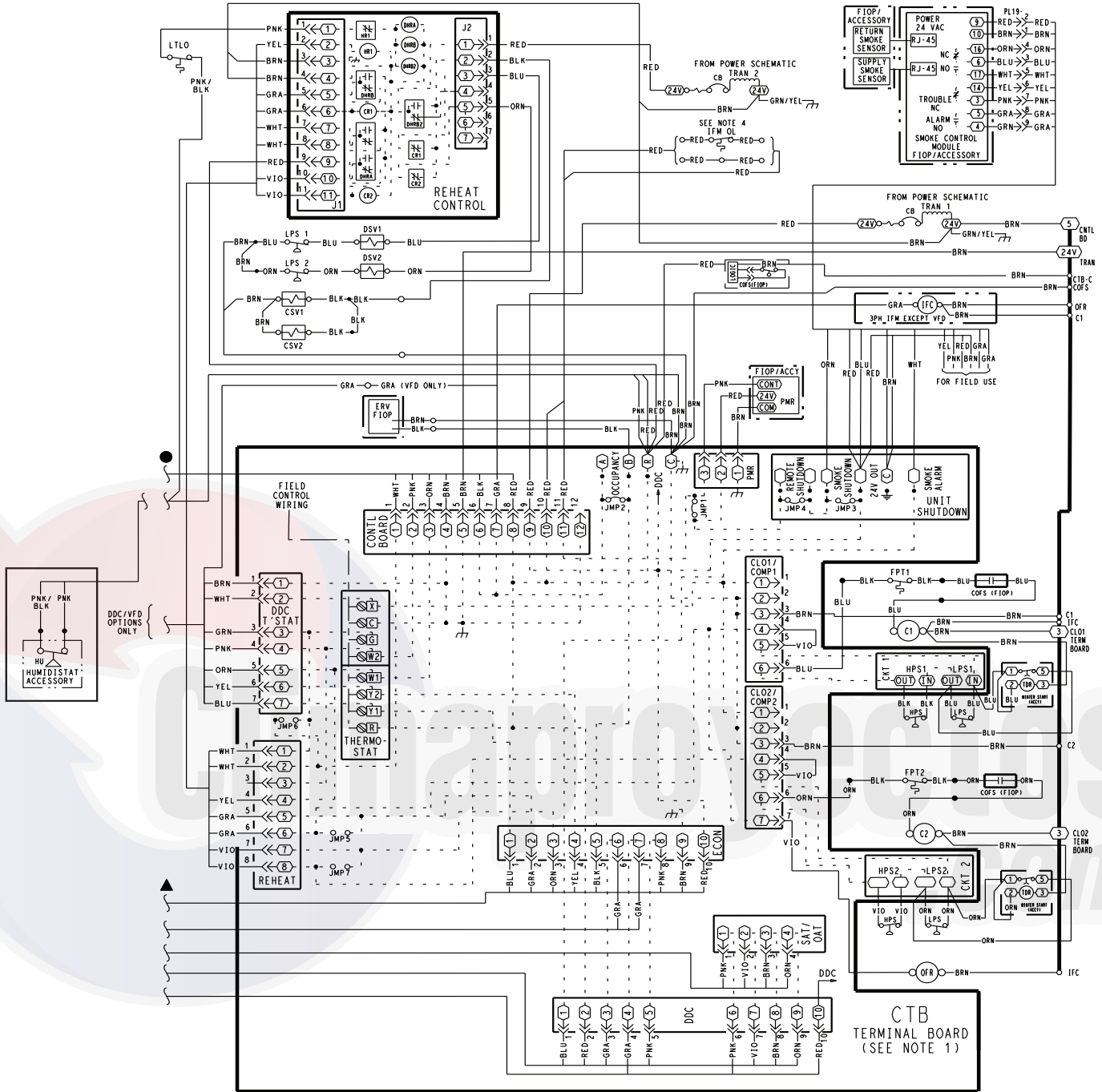

Fig. 33 — Accessory Field-Installed Humidistat



YAC CONTROL 208/230V, 460V, 575V
 7.5-10TON (2)COMPR T1 W/ DEHUMIDIFICATION

48TM502386 N

Fig. 34 — 48TC*B07 (Unit with Humidi-MiZer® Adaptive Dehumidification System) Humidistat Wiring



Fig. 35 — Edge® Pro Thermostat

EDGE Pro THERMIDISTAT

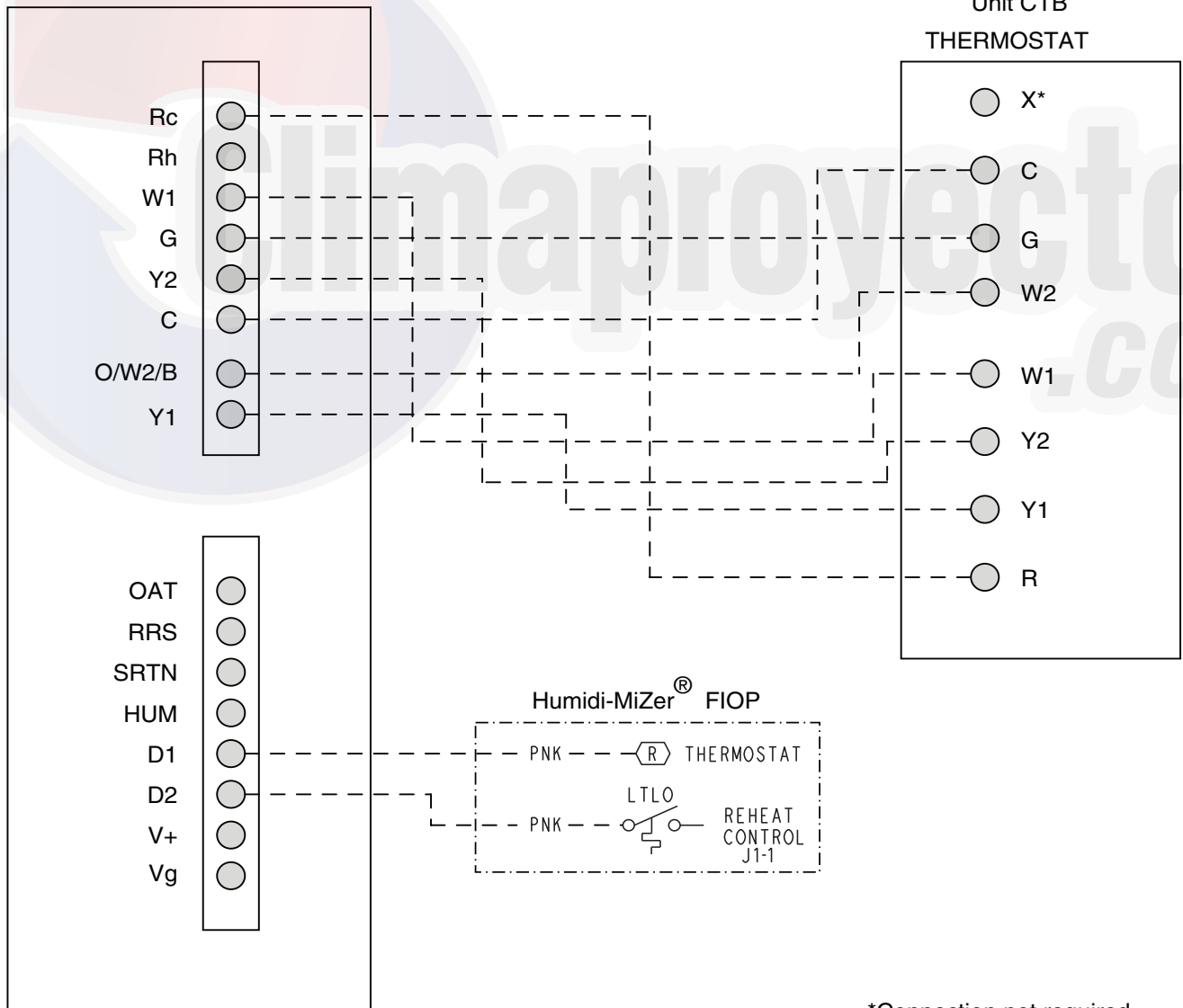

*Connection not required.

Fig. 36 — 48TC*B07 (Unit with Humidi-MiZer Adaptive Dehumidification System)

ECONOMISER® X (FACTORY-INSTALLED OPTION)

Product Description — The EconoMiSer X system is an expandable economizer control system, which includes a W7220 economizer module (controller) with an LCD and keypad (see Fig. 37). The W7220 can be configured with optional sensors.



Fig. 37 — W7220 Economizer Module

The W7220 economizer module can be used as a stand-alone economizer module wired directly to a commercial set-back space thermostat and sensors to provide outside air dry-bulb economizer control.

The W7220 economizer module can be connected to optional sensors for single or differential enthalpy control. The W7220 economizer module provides power and communications for the sensors.

The W7220 economizer module automatically detects sensors by polling to determine which sensors are present. If a sensor loses communications after it has been detected, the W7220 economizer controller indicates a device fail error on its LCD.

System Components — The EconoMiSer X system includes an economizer module, 20k mixed air sensor, damper actuator, and either a 20k outdoor air temperature sensor or S-Bus enthalpy sensors.

Economizer Module — The economizer module is the core of the EconoMiSer X system. The module is mounted in the unit's control box, and includes the user interface for the system. The W7220 economizer module provides the basic inputs and outputs to provide simple economizer control. When used with the optional sensors, the economizer module provides more advanced economizer functionality.

S-Bus Enthalpy Control Sensors — This sensor is a combination temperature and humidity sensor which is powered by and communicates on the S-Bus. Up to three sensors may be configured with the W7220 economizer module. See page 24 for details.

CO₂ Sensor (optional) — A CO₂ sensor can be added for Demand Controlled Ventilation (DCV).

Specifications

W7220 Economizer Module — The module is designed for use with 2 to 10 Vdc or bus communicating actuator. The module includes terminals for CO₂ sensor, mixed air sensor, and an outdoor dry bulb sensor. Enthalpy and other options are available with bus sensors.

User Interface — Provides status for normal operation, setup parameters, checkout tests, and alarm and error conditions with a 2-line 16 character LCD display and four button keypad.

Electrical

Rated Voltage — 20 to 30 Vac RMS, 50/60 Hz

Transformer — 100 va maximum system input

Nominal Power Consumption (at 24 Vac, 60 Hz) — 11.5 VA without sensors or actuators

Relay Digital Output Rating at 30 Vac (maximum power from Class 2 input only) — 1.5A run:

3.5A inrush at 0.45PF (200,000 cycles) or

7.5A inrush at 0.45PF (100,000 cycles)

External Sensors Power Output — 21 Vdc \pm 5% at 48mA

IMPORTANT: All inputs and outputs must be Class 2 wiring.

Inputs

Sensors

NOTE: A Mixed Air (MA) analog sensor is required on all W7220 units; either an Outdoor Air (OA) sensor for dry bulb change over or an OA bus sensor for outdoor enthalpy change over is required in addition to the MA sensor. An additional Return Air (RA) bus sensor can be added to the system for differential enthalpy or dry bulb changeover. For differential dry bulb changeover a 20k ohm sensor is required in the OA and a bus sensor in the RA. DIP switch on RA bus sensor must be set in the RA position.

Dry Bulb Temperature (optional) and Mixed Air (required), 20k NTC

2-wire (18 to 22 AWG);

Temperature range -40 to 150 F (-40 to 65 C)

Temperature accuracy -0 F/+2 F

Temperature and Humidity, C7400S1000 (optional)

S-Bus; 2-wire (18 to 22 AWG)

Temperature: range -40 to 150 F (-40 to 65 C)

Temperature accuracy -0 F/+2F

Humidity: range 0 to 100% RH with 5% accuracy.

NOTE: Up to three (3) S-Bus sensors may be connected to the W7220 economizer module. For outdoor air (OA), return air (RA) and discharge (supply) air (DA).

4 Binary Inputs

1-wire 24 Vac + common GND (see page 25 for wiring details).

24 Vac Power Supply

20 to 30 Vac 50/60Hz;

100 VA Class 2 transformer.

Outputs

Actuator Signal

2-10 Vdc; minimum actuator impedance is 2k ohm; bus two-wire output for bus communicating actuators.

Exhaust fan, Y1, Y2 and AUX1

All Relay Outputs (at 30 Vac):

Running: 1.5A maximum

Inrush: 7.5A maximum

Environmental

Operating Temperature

-40 to 150 F (-40 to 65 C).

Exception of display operation down to -4 F with full recovery at -4 F from exposure to -40 F

Storage Temperature

-40 to 150 F (-40 to 65 C)

Shipping Temperature

-40 to 150 F (-40 to 65 C)

Relative Humidity

5% to 95% RH non-condensing

ECONOMIZER MODULE WIRING DETAILS — Use Fig. 38 and Tables 9 and 10 to locate the wiring terminals for the Economizer module.

NOTE: The four terminal blocks are removable. You can slide out each terminal block, wire it, and then slide it back into place.

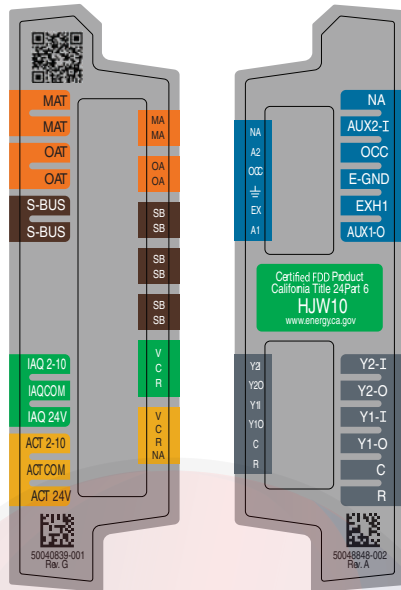

Fig. 38 — W7220 Wiring Terminals

S-Bus Sensor Wiring — The labels on the sensors and controller are color coded for ease of installation. Orange labeled sensors can only be wired to orange terminals on the controller. Brown labeled sensors can only be wired to S-bus (brown) terminals. Use Fig. 38 and Table 9 to locate the wiring terminals for each S-Bus sensor.

Use Fig. 38 and Table 10 to set the DIP switches for the desired use of the sensor.

Table 9 — Economizer Module - Left Hand Terminal Blocks

LABEL	TYPE	DESCRIPTION
Top Left Terminal Block		
MAT MAT	20k NTC and COM	Mixed Air Temperature Sensor (Polarity Insensitive Connection)
OAT OAT	20k NTC and COM	Outdoor Air Temperature Sensor (Polarity Insensitive Connection)
S-BUS S-BUS	S-BUS (Syk Bus)	Enthalpy Control Sensor (Polarity Insensitive Connection)
Bottom Left Terminal Block		
IAQ 2-10	2-10 vdc	Air Quality Sensor Input (e.g. CO ₂ sensor)
IAQ COM	COM	Air Quality Sensor Common
IAQ 24V	24 vac	Air Quality Sensor 24 vac Source
ACT 2-10	2-10 vdc	Damper Actuator Output (2-10 vdc)
ACT COM	COM	Damper Actuator Output Common
ACT 24v	24 vac	Damper Actuator 24 vac Source

Table 10 — Economizer Module - Right Hand Terminal Blocks

LABEL	TYPE	DESCRIPTION
Top Right Terminal Blocks		
AUX2 I	24 vac IN	The first terminal is not used.
OCC	24 vac IN	Shut Down (SD) or HEAT (W) Conventional only and Heat Pump Changeover (O-B) in Heat Pump mode.
E-GND	E-GND	Occupied/Unoccupied Input
EXH1	24 vac OUT	Exhaust Fan 1 Output
AUX1 O	24 vac OUT	Programmable: Exhaust fan 2 output or ERV or System alarm output
Bottom Right Terminal Blocks		
Y2-I	24 vac IN	Y2 in - Cooling Stage 2 Input from space thermostat
Y2-O	24 vac OUT	Y2 out - Cooling Stage 2 Output to stage 2 mechanical cooling
Y1-I	24 vac IN	Y1 in - Cooling Stage 2 Input from space thermostat
Y1-O	24 vac OUT	Y1 out - Cooling Stage 2 Output to stage 2 mechanical cooling
C	COM	24 vac Common
R	24 vac	24 vac Power (hot)

Use Fig. 39 and Table 11 to locate the wiring terminals for each enthalpy control sensor.

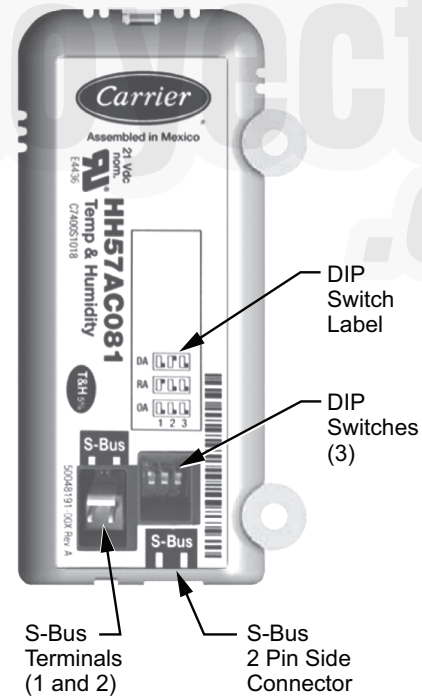

Fig. 39 — S-Bus Sensor DIP Switches

Table 11 — HH57AC081 Sensor Wiring Terminations

TERMINAL		TYPE	DESCRIPTION
NUMBER	LABEL		
1	S-BUS	S-BUS	S-BUS Communications (Enthalpy Control Sensor Bus)
2	S-BUS	S-BUS	S-BUS Communications (Enthalpy Control Sensor Bus)

Use Fig. 39 and Table 12 to set the DIP switches for the desired use of the sensor.

Table 12 — HH57AC081 Sensor DIP Switch

USE	DIP SWITCH POSITIONS FOR SWITCHES 1, 2, AND 3		
	1	2	3
DA	OFF	ON	OFF
RA	ON	OFF	OFF
OA	OFF	OFF	OFF

NOTE: When a S-bus sensor is connected to an existing network, it will take 60 minutes for the network to recognize and auto-configure itself to use the new sensor.

During the 60 minute setup period, no alarms for sensor failures (except SAT) will be issued and no economizing function will be available.

CO₂ Sensor Wiring — When using a CO₂ sensor the black and brown common wires are internally connected and only one is connected to “IAQ COM” on the W7220. Use the power from the W7220 to power the CO₂ sensor OR make sure the ground for the power supplies are common. See Fig. 40 for CO₂ sensor wiring.

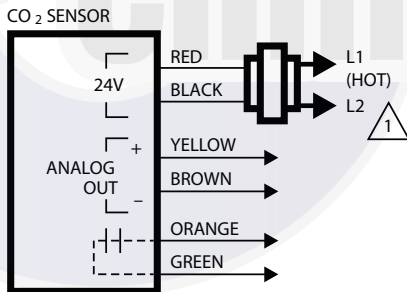

1 POWER SUPPLY. PROVIDE DISCONNECT MEANS AND OVERLOAD PROTECTION AS REQUIRED.

Fig. 40 — CO₂ Sensor Wiring

INTERFACE OVERVIEW — This section describes how to use the Economizer’s user interface for:

- Keypad and menu navigation
- Settings and parameter changes
- Menu structure and selection

User Interface — The user interface consists of a 2-line LCD display and a 4-button keypad on the front of the economizer controller.

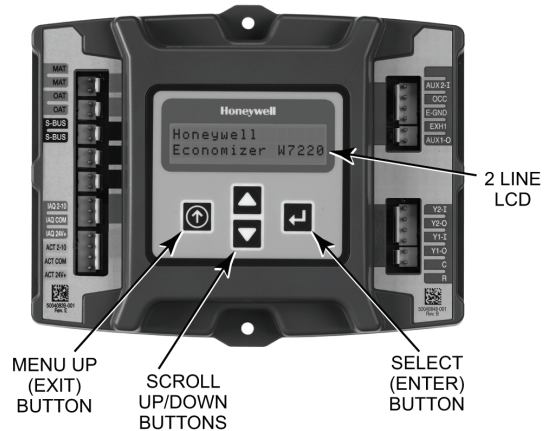

Fig. 41 — W7220 Controller Button Description

Keypad — The four navigation buttons (see Fig. 41) are used to scroll through the menus and menu items, select menu items, and to change parameter and configuration settings.

To use the keypad when working with menus:

- Press the ▲ (Up arrow) button to move to the previous menu.
- Press the ▼ (Down arrow) button to move to the next menu.
- Press the (Enter) button to display the first item in the currently displayed menu.

Press the ⌂ (Menu Up/Exit) button to exit a menu’s item and return to the list of menus. To use the keypad when working with Setpoints, System and Advanced Settings, Checkout tests and Alarms:

1. Navigate to the desired menu.
 2. Press the (Enter) button to display the first item in the currently displayed menu.
 3. Use the ▲ (Up arrow) and ▼ (Down arrow) buttons to scroll to the desired parameter.
 4. Press the (Enter) button to display the value of the currently displayed item.
 5. Press the ▲ button to increase (change) the displayed parameter value.
 6. Press the ▼ button to decrease (change) the displayed parameter value.
- NOTE: When values are displayed, pressing and holding the or button causes the display to automatically increment.
7. Press the (Enter) button to accept the displayed value and store it in nonvolatile RAM.
 8. “CHANGE STORED” displays.
 9. Press the (Enter) button to return to the current menu parameter.
 10. Press the (MENU Up/Exit) button to return to the previous menu.

Menu Structure — Table 13 illustrates the complete hierarchy of menus and parameters for the EconoMiSer® X system.

The Menus in display order are:

- STATUS
- SETPOINTS
- SYSTEM SETUP
- ADVANCED SETUP
- CHECKOUT
- ALARMS

IMPORTANT: Table 13 illustrates the complete hierarchy. Your menu parameters may be different depending on your configuration.

For example if you do not have a DCV (CO₂) sensor, then none of the DCV parameters appear and only MIN POS will display. If you have a CO₂ sensor, the DCV MIN and DCV MAX will appear AND if you have 2 speed fan DCV MIN (high and low speed) and DCV MAX (high and low speed) will appear.

NOTE: Some parameters in the menus use the letters MA or MAT, indicating a mixed air temperature sensor location before the cooling coil. This unit application has the control sensor located after the cooling coil, in the fan section, where it is designated as (Cooling) Supply Air Temperature or SAT sensor.

Setup and Configuration — Before being placed into service, the W7220 Economizer module must be setup and configured for the installed system.

IMPORTANT: During setup, the Economizer module is live at all times.

The setup process uses a hierarchical menu structure that is easy to use. You press the and arrow buttons to move forward and backward through the menus and press the button to select and confirm setup item changes.

See Table 14 for damper minimum position settings and readings on the checkout menus.

Time-Out and Screen-Saver — When no buttons have been pressed for 10 minutes, the LCD displays a screen saver, which cycles through the Status items. Each Status items displays in turn and cycles to the next item after 5 seconds.

1 and 2 Speed Fan Operation — For 1 speed fan dry bulb and enthalpy operation see Tables 15-18. For 2 speed fan operation see Tables 19-22.



Table 13 — Menu Structure

MENU	PARAMETER	PARAMETER DEFAULT VALUE	PARAMETER RANGE AND INCREMENT	NOTES
STATUS	ECONO AVAIL	NO	YES/NO	FIRST STAGE COOLING DEMAND (Y1-IN) YES = economizing available; the system can use outside air for free cooling when required
	ECONOMIZING	NO	YES/NO	FIRST STAGE COOLING RELAY OUTPUT YES = outside air being used for 1 stage cooling
	OCCUPIED	NO	YES/NO	OCCUPIED YES = OCC signal received from space thermostat or unitary controller YES = 24 Vac on terminal OCC NO = 0 Vac on terminal OCC
	HEAT PUMP	N/A	COOL HEAT	HEAT PUMP MODE Displays COOL or HEAT when system is set to heat pump (Non-conventional)
	COOL Y1—IN	OFF	ON/OFF	FIRST STAGE COOLING DEMAND (Y1-IN) Y1-I signal from space thermostat or unitary controller for cooling stage 1. ON = 24 Vac on terminal Y1-I OFF = 0 Vac on terminal Y1-I
	COOL Y1—OUT	OFF	ON/OFF	FIRST STAGE COOLING RELAY OUTPUT Cool stage 1 Relay Output to stage 1 mechanical cooling (Y1—OUT terminal)
	COOL Y2—IN	OFF	ON/OFF	SECOND STAGE COOLING DEMAND (Y2-IN) Y2-I signal from space thermostat our unitary controller for second stage cooling. ON = 24 Vac on terminal Y2-I OFF = 0 Vac on terminal Y2-I
	COOL Y2—OUT	OFF	ON/OFF	SECOND STAGE COOLING RELAY OUTPUT Cool Stage 2 Relay Output to mechanical cooling (Y2—OUT terminal)
	MA TEMP	___ . _ F	0 to 140 F	SUPPLY AIR TEMPERATURE, Cooling Mode Displays value of measured mixed air from MAT sensor. Displays ___ . _ F if not connected, short or out-of-range.
	DA TEMP	___ . _ F	0 to 140 F	DISCHARGE AIR TEMPERATURE, after Heating section Displays when Discharge Air sensor is connected and displays measured discharge temperature. Displays ___ . _ F if sensor sends invalid value, if not connected, short or out-of-range.
	OA TEMP	___ . _ F	-40 to 140 F	OUTSIDE AIR TEMP Displays measured value of outdoor air temperature. Displays ___ . _ F if sensor sends invalid value, short or out-of-range.
	OA HUM	__ %	0 to 100%	OUTSIDE AIR RELATIVE HUMIDITY Displays measured value of outdoor humidity from OA sensor. Displays __ % if not connected short, or out-of-range.
	RA TEMP	___ . _ F	0 to 140 F	RETURN AIR TEMPERATURE Displays measured value of return air temperature from RAT sensor. Displays ___ . _ F if sensor sends invalid value, if not connected, short or out-of-range
	RA HUM	__ %	0 to 100%	RETURN AIR RELATIVE HUMIDITY Displays measured value of return air humidity from RA sensor. Displays __ % if sensor sends invalid value, if not connected, short or out-of-range
	IN CO2	___ ppm	0 TO 2000 ppm	SPACE/RETURN AIR CO ₂ Displays value of measured CO ₂ from CO ₂ sensor. Invalid if not connected, short or out-of-range
	DCV STATUS	N/A	ON/OFF	DEMAND CONTROLLED VENTILATION STATUS Displays ON if above setpoint and OFF if below setpoint, and ONLY if a CO ₂ sensor is connected.
	DAMPER OUT	2.0v	2.0 TO 10.0v	Displays voltage output to the damper actuator.
	ACT POS	N/A	0 to 100%	Displays actual position of outdoor air damper actuator

Table 13 — Menu Structure (cont)

MENU	PARAMETER	PARAMETER DEFAULT VALUE	PARAMETER RANGE AND INCREMENT	NOTES
STATUS (CONT)	ACT COUNT	N/A	1 to 65535	Displays number of times actuator has cycled. 1 cycles equals 180 deg. of actuator movement in any direction.
	ACTUATOR	N/A	OK/Alarm (on Alarm menu)	Displays ERROR if voltage or torque is below actuator range.
	EXH1 OUT	OFF	ON/OFF	EXHAUST STAGE 1 RELAY OUTPUT Output of EXH1 terminal: ON = relay closed OFF = relay open
	EXH2 OUT	OFF	ON/OFF	EXHAUST STAGE 2 RELAY OUTPUT Output of AUX terminal; displays only if AUX = EXH2
	ERV	OFF	ON/OFF	ENERGY RECOVERY VENTILATOR Output of AUX terminal; displays only if AUX = ERV
	MECH COOL ON or HEAT STAGES ON	0	0, 1, or 2	Displays stage of mechanical cooling that is active. Displays the stage of heat pump heating that is active.
	FAN SPEED	N/A	LOW or HIGH	SUPPLY FAN SPEED Displays speed setting of fan on a 2-speed fan unit.
	W (HEAT ON)	N/A	ON/OFF	HEAT DEMAND STATUS Displays status of heat demand on a 2-speed fan unit.
SETPOINTS	MAT SET	53F	38 to 65F; increment by 1	SUPPLY AIR SETPOINT Setpoint determines where the economizer will modulate the OA damper to maintain the mixed air temperature.
	LOW T LOCK	32F	-45 to 80 F; increment by 1	COMPRESSOR LOW TEMPERATURE LOCKOUT Setpoint determines outdoor temperature when the mechanical cooling cannot be turned on. Commonly referred to as the Compressor lockout.
	DRYBLB SET	63F	48 to 80F; increment by 1	OA DRY BULB TEMPERATURE CHANGEOVER SETPOINT Setpoint determines where the economizer will assume outdoor air temperature is good for free cooling; e.g.; at 63 F unit will economize at 62 F and below and not economize at 64 F and above. There is a 2 F dead-band.
	ENTH CURVE	ES3	ES1,ES2,ES3,ES4, or ES5	ENTHALPY CHANGEOVER CURVE Enthalpy boundary "curves" for economizing using single enthalpy.
	DCV SET	1100ppm	500 to 2000ppm; increment by 100	DEMAND CONTROLLED VENTILATION Displays only if CO ₂ sensor is connected. Setpoint for Demand Control Ventilation of space. Above the setpoint, the OA dampers will modulate open to bring in additional OA to maintain a space ppm level below the setpoint.
	MIN POS	2.8 V	2 to 10 Vdc	VENTILATION MINIMUM POSITION Displays ONLY if a CO ₂ sensor is NOT connected.
	VENTMAX With 2-speed fan units VENTMAX L (low speed fan) and VENTMAX H (high speed fan) settings are required	2.8 V	2 to 10 Vdc	DCV MAXIMUM DAMPER POSITION Displays only if a CO ₂ sensor is connected. Used for Vbz (ventilation max cfm) setpoint. Displays 2 to 10 V if <3 sensors (RA,OA, and MA). In AUTO mode dampers controlled by CFM.
			100 to 9990 cfm; increment by 10	If OA, MA, RA, and CO ₂ sensors are connected and DCV CAL ENABLE is set to AUTO mode, the OA dampers are controlled by CFM and displays from 100 to 9990 CFM.
			2 to 10 Vdc	With 2-speed fan units VENT L (low speed fan) and MIN POS H (high speed fan) settings are required. Default for VENTMAX L is 3.2V and VENTMAX H is 2.8V
	VENTMIN With 2-speed fan units VENTMIN L (low speed fan) and VENTMIN H (high speed fan) set	2.25 V	2 to 10 Vdc or 100 to 9990 cfm increment by 10	DCV MINIMUM DAMPER POSITION Displays only if a CO ₂ sensor is connected. Used for Ba (ventilation min cfm) setpoint. Displays 2 to 10 V if <3 sensors (RA, OA, and MA). Va is only set if DCV is used. This is the ventilation for less than maximum occupancy of the space. In AUTO mode dampers controlled by CFM.
			100 to 9990 cfm; increment by 10	If OA, MA, RA, and CO ₂ sensors are connected and DCV CAL ENABLE is set to AUTO mode, the OA dampers are controlled by CFM and displays from 100 to 9990 CFM.
2 to 10 Vdc			With 2-speed fan units VENTMIN L (low speed fan) and MIN POS H (high speed fan) settings are required. Default for VENTMIN L is 3.2V and VENTMIN H is 2.8V	
ERV OAT SP	32°F	0 to 50F; increment by 1	ENERGY RECOVERY VENTILATOR UNIT OUTDOOR AIR TEMPERATURE SETPOINT Only when AUX1 O = ERV	
EXH1 SET With 2-speed fan units Exh1 L (low speed fan) and Exh1 H (high speed fan) settings are required	50%	0 to 100%; increment by 1	EXHAUST FAN STAGE 1 SETPOINT Setpoint for OA damper position when exhaust fan 1 is powered by the economizer. With 2-speed fan units Exh1 L (low speed fan) and Exh1 H (high speed fan) settings are required. Default for Exh1 L is 65% and Exh1 H is 50%	
EXH2 SET With 2-speed fan units Exh2 L (low speed fan) and Exh2 H (high speed fan) settings are required	75%	0 to 100%; increment by 1	EXHAUST FAN STAGE 2 SETPOINT Setpoint for OA damper position when exhaust fan 2 is powered by the economizer. Only used when AUX1 O is set to EXH2. With 2-speed fan units Exh2 L (low speed fan) and Exh2 H (high speed fan) settings are required. Default for Exh2 L is 80% and Exh2 H is 75%	

Table 13 — Menu Structure (cont)

MENU	PARAMETER	PARAMETER DEFAULT VALUE	PARAMETER RANGE AND INCREMENT	NOTES
SYSTEM SETUP	INSTALL	01/01/10	N/A	Display order = MM/DD/YY Setting order = DD, MM, then YY.
	UNITS DEG	F	F or C	Sets economizer controller in degrees Fahrenheit or Celsius
	EQUIPMENT	CONV	Conventional or HP	CONV = conventional; HP O/B = Enable Heat Pump mode. Use AUX2 I for Heat Pump input from thermostat or controller. See Menu Note 4
	AUX2 IN	W	SD/W or HP(O)/HP(B)	In CONV mode: SD + Enables configuration of shutdown (default); W = Informs controller that system is in heating mode. NOTE: If using 2-speed fan mode, you must program CONV mode for W. Shutdown is not available in 2-speed fan mode. See Menu Note 4. In HP O/B mode: HP(O) = energize heat pump on Cool (default); HP(B) = energize heat pump on heat.
	FAN SPEED	2 speed	1 speed/2 speed	Sets the economizer controller for operation of 1 speed or 2 speed supply fan. NOTE: 2-speed fan option also needs Heat (W1) programmed in AUX 2 In. See Menu Note 4.
	FAN CFM	5000cfm	100 to 15000 cfm; increment by 100	UNIT DESIGN AIRFLOW (CFM) Enter only if using DCVAL ENA = AUTO The value is dounf on the nameplate label for the specific unit.
	AUX1 OUT	NONE	NONE ERV EXH2 SYS	Select OUTPUT for AUX1 O relay • NONE = not configured (output is not used) • ERV = Energy Recovery Ventilator • EXH2 = second damper position relay closure for second exhaust fan • SYS = use output as an alarm signal
	OCC	INPUT	INPUT or ALWAYS	OCCUPIED MODE BY EXTERNAL SIGNAL When using a setback thermostat with occupancy out (24 vac), the 24 vac is input "INPUT" to the OCC terminal. If no occupancy output from the thermostat then change program to "ALWAYS" OR add a jumper from terminal R to OCC terminal.
	FACTORY DEFAULT	NO	NO or YES	Resets all set points to factory defaults when set to YES. LCD will briefly flash YES and change to NO but all parameters will change to the factory default values. NOTE: RECHECK AUX2 IN and FANTYPE for required 2-speed values.
ADVANCED SETUP	MA LO SET	45°F	35 to 55 F; Incremented by 10	SUPPLY AIR TEMPERATURE LOW LIMIT Temperature to achieve Freeze Protection (close damper and alarm if temperature falls below setup value).
	FREEZE POS	CLO	CLO or MIN	FREEZE PROTECTION DAMPER POSITION Damper position when freeze protection is active (closed or MIN POS).
	CO2 ZERO	0ppm	0 to 500 ppm; Increment by 10	CO ₂ ppm level to match CO ₂ sensor start level.
	CO2 SPAN	2000ppm	1000 to 3000 ppm; Increment by 10	CO ₂ ppm span to match CO ₂ sensor.
	STG3 DLY	2.0h	0 min, 5 min, 15 min, then 15 min intervals. Up to 4 hrs or OFF	COOLING STAGE 3 DELAY Delay after stage 2 cool has been active. Turns on second stage of cooling when economizer is first stage and mechanical cooling is second stage. Allows three stages of cooling, 1 economizer and 2 mechanical. OFF = no Stage 3 cooling
	SD DMPR POS	CLO	CLO or OPN	Indicates shutdown signal from space thermostat or unitary controller. When controller receives 24 Vac input on the SD terminal in conventional mode, the OA damper will open if programmed for OPN and OA damper will close if programmed for CLO. All other controls, e.g., fans, etc. will shut off.
	DA LO ALM	45 F (7 C)	35 to 65 F; (2 to 18 C) Incremented by 5 deg.	Used for alarm for when the DA air temperature is too low. Set lower range of alarm, below this temperature the alarm will show on the display.
	DA HI ALM	80 F (27 C)	70 to 80 F; (21 to 82 C) Incremented by 5 deg.	Used for alarm for when the DA air temperature is too high. Set upper range of alarm, above this temperature the alarm will show on the display.
	DCVCAL ENA	MAN	MAN (manual) AUTO	Turns on the DCV automatic control of the dampers. Resets ventilation based on the RA, OA, and MA sensor conditions. Requires all 3 RA, OA, and MA sensors.

Table 13 — Menu Structure (cont)

MENU	PARAMETER	PARAMETER DEFAULT VALUE	PARAMETER RANGE AND INCREMENT	NOTES
ADVANCED SETUP (CONT)	MAT T CAL	0.0°F	±2.5 F	SUPPLY AIR TEMPERATURE CALIBRATION Allows for the operator to adjust for an out of calibration temperature sensor.
	OAS T CAL	0.0°F	±2.5 F	OUTSIDE AIR TEMPERATURE CALIBRATION Allows for the operator to adjust for an out of calibration temperature sensor.
	OA H CAL	0% RH	±10% RH	OUTSIDE AIR HUMIDITY CALIBRATION Allows for operator to adjust for an out of calibration humidity sensor.
	RA T CAL	0.0°F	±2.5 F	RETURN AIR TEMPERATURE CALIBRATION Allows for the operator to adjust for an out of calibration temperature sensor.
	RA H CAL	0% RH	±10% RH	RETURN AIR HUMIDITY CALIBRATION Allows for operator to adjust for an out of calibration humidity sensor.
	DA T CAL	0.0°F	±2.5 F	DISCHARGE AIR TEMPERATURE CALIBRATION Allows for the operator to adjust for an out of calibration temperature sensor.
	2SP FAN DELAY	5 Minutes	0 to 20 minutes in 1 minute increments	TIME DELAY ON 2nd STAGE ECONOMIZING When in economizing mode this is the delay for the high speed fan to try to satisfy the call for second stage cooling before the first stage mechanical cooling is enabled.
CHECKOUT	DAMPER MINIMUM POSITION	N/A	N/A	The checkout for the damper minimum position is based on the system. See Table 14.
	DAMPER OPEN	N/A	N/A	Position damper to the full open position. Exhaust fan contacts enable during the DAMPER OPEN test. Make sure you pause in the mode to allow exhaust contacts to energize due to the delay in the system.
	DAMPER CLOSE	N/A	N/A	Positions damper to the fully closed position
	CONNECT Y1-O	N/A	N/A	Closes the Y1-O relay (Y1-O)
	CONNECT Y2-O	N/A	N/A	Closes the Y2-O relay (Y2-O)
	CONNECT AUX1-O	N/A	N/A	Energizes the AUX output. If Aux setting is: • NONE — not action taken • ERV — 24 Vac out. Turns on or signals an ERV that the conditions are not good for economizing but are for ERV operation. • SYS — 24 Vac out. Issues a system alarm
ALARMS	CONNECT EXH1	N/A	N/A	Closes the power exhaust fan 2 relay (EXH1)
				Alarms display only when they are active. The menu title "ALARMS(#)" includes the number of active alarms in parenthesis (). When using SYLK bus sensors, "SYLK" will appear on the screen, and when using 20k OA temperature sensors, "SENS T" will appear on the screen
	MA T SENS ERR	N/A	N/A	SUPPLY AIR TEMPERATURE SENSOR ERROR Mixed air sensor has failed or become disconnected - check wiring then replace sensor if the alarm continues.
	CO2 SENS ERR	N/A	N/A	CO ₂ SENSOR ERROR CO ₂ sensor has failed, gone out of range or become disconnected - check wiring then replace sensor if the alarm continues.
	OA SYLK T ERR	N/A	N/A	OUTSIDE AIR S-BUS SENSOR ERROR Outdoor air enthalpy sensor has failed or become disconnected - check wiring then replace sensor if the alarm continues.
	OA SYLK H ERR	N/A	N/A	Outdoor air enthalpy sensor has failed or become disconnected - check wiring then replace sensor if the alarm continues.
	RA SYLK T ERR	N/A	N/A	RETURN AIR S-BUS SENSOR ERROR Return air enthalpy sensor has failed or become disconnected - check wiring then replace sensor if the alarm continues.
	RA SYLK H ERR	N/A	N/A	Return air enthalpy sensor has failed or become disconnected - check wiring then replace sensor if the alarm continues.
	DA SYLK T ERR	N/A	N/A	DISCHARGE AIR S-BUS SENSOR ERROR Discharge air sensor has failed or become disconnected - check wiring then replace sensor if the alarm continues.
	DA SYLK H ERR	N/A	N/A	Discharge air sensor has failed or become disconnected - check wiring then replace sensor if the alarm continues.
OA SENS T ERR	N/A	N/A	OUTSIDE AIR TEMPERATURE SENSOR ERROR Outdoor air temperature sensor has failed or become disconnected - check wiring then replace if the alarm continues.	
ACT ERROR	N/A	N/A	ACTUATOR ERROR Actuator has failed or become disconnected - check for stall, over voltage, under voltage and actuator count. Replace actuator if damper is movable and supply voltage is between 21.6 V and 26.4 V. Check actuator count on STATUS menu.	
FREEZE ALARM	N/A	N/A	Check if outdoor temperature is below the LOW Temp Lockout on setpoint menu. Check if mixed air temperature on STATUS menu is below the Lo Setpoint on Advanced menu. When conditions are back in normal range then the alarm will go away.	

Table 13 — Menu Structure (cont)

MENU	PARAMETER	PARAMETER DEFAULT VALUE	PARAMETER RANGE AND INCREMENT	NOTES
ALARMS (CONT)	SHUTDOWN ACTIVE	N/A	N/A	AUX2 IN is programmed for SHUTDOWN and 24 V has been applied to AUX 2IN terminal.
	DMP CAL RUNNING	N/A	N/A	DAMPER CALIBRATION ROUTINE RUNNING If DCV Auto enable has been programmed, when the W7220 is completing a calibration on the dampers, this alarm will display. Wait until the calibration is completed and the alarm will go away. Must have OA, MA and RA sensors for DCV calibration; set up in the Advanced setup menu.
	DA SENS ALM	N/A	N/A	DISCHARGE AIR TEMPERATURE SENSOR ALARM Discharge air temperature is out of the range set in the ADVANCED SETUP Menu. Check the temperature of the discharge air.
	SYS ALARM	N/A	N/A	When AUX1-0 is set to SYS and there is any alarm (e.g., failed sensors, etc.), the AUX1-0 terminal has 24 Vac out.
	ACT UNDER V	N/A	N/A	ACTUATOR VOLTAGE LOW Voltage received by actuator is above expected range.
	ACT OVER V	N/A	N/A	ACTUATOR VOLTAGE HIGH Voltage received by actuator is below expected range.
	ACT STALLED	N/A	N/A	ACTUATOR STALLED Actuator stopped before achieving commanded position.

LEGEND

- CLO** — Compressor Lockout
- DCV** — Demand Controlled Ventilation
- ERV** — Energy Recovery Ventilator
- LCD** — Liquid Crystal Display
- MA** — Mixed Air
- MAT** — Mixed Air Temperature
- N/A** — Not Applicable
- OA** — Outdoor Air
- OAT** — Outdoor Air Temperature
- OCC** — Occupied
- RA** — Return Air
- RAT** — Return Air Temperature
- RTU** — Rooftop Unit
- SYS** — System

* Table 13 illustrates the complete hierarchy. Your menu parameters may be different depending on your configuration. For example if you do not have a DCV (CO₂) sensor, then none of the DCV parameters appear.

† When values are displayed, pressing and holding the ▲ or ▼ button causes the display to automatically increment.

** N/A = Not Applicable.

†† ERV Operation: When in cooling mode AND the conditions are NOT OK for economizing - the ERV terminal will be energized. In the Heating mode, the ERV terminal will be energized when the OA is below the ERV OAT setpoint in the setpoint menu.

NOTES:

1. STATUS → OCCUPIED — The factory-standard Occupancy signal originates with a thermostat or other controller call for indoor fan operation at CTB terminal G. This signal passes through the Central Terminal Board's OCCUPIED jumper JMP1 to the ECONO connector and to the W7220's OCC input terminal. An external timeclock or relay is required to implement an Occupancy schedule on the economizer damper position.
2. STATUS → MA TEMP, SETPOINTS → MAT SET — The W7220 menu parameters and labels include designations MA, MAT and Mixed Air for the economizer cooling control sensor. On these rooftop units, the economizer control sensor is located downstream of the evaporator/indoor coil in the supply fan section where this sensor is designated as Supply Air Temperature (SAT) sensor.
3. SETPOINTS → DRYBLB SET — This point is not displayed if a Return Air (differential) temperature sensor or an Outdoor Air enthalpy sensor is connected.
4. SYSTEM SETUP parameters must be configured as noted for 2-Speed unit operation:
EQUIPMENT = CONV
AUX2 I = W
FAN TYPE = 2SPEED

Table 14 — Damper Minimum Position Settings and Readings on Checkout Menu

FAN SPEED	DEMAND CONTROLLED VENTILATION (CO ₂ SENSOR)	SETPOINTS	CHECKOUT
1	NO	MIN POS	VMAX-HS
1	NO	N/A	N/A
2	NO	MIN POS H	VMAX-HS
2	NO	MIN POS L	VMAX-LS
1	YES	VENT MIN	VMAX-HS
1	YES	VENT MAX	VMAX-HS
2	YES	VENT MIN H	VMAX-HS
2	YES	VENT MAX H	VMAX-LS
2	YES	VENT MIN L	N/A
2	YES	VENT MAX L	N/A

Table 15 — Dry Bulb Operation No DCV (CO₂ Sensor) — 1 Speed Fan

DEMAND CONTROLLED VENTILATION (DCV)	OUTSIDE AIR GOOD TO ECONOMIZE	Y1-I	Y2-I	FAN SPEED	Y1-O	Y2-O	OCCUPIED	UNOCCUPIED
NONE	NO	OFF	OFF	HIGH	0v/Off	0v/Off	MIN POS	Closed
		ON	OFF	HIGH	24v/On	0v/Off	MIN POS	Closed
		ON	ON	HIGH	24v/On	24v/On	MIN POS	Closed
NONE	YES	OFF	OFF	HIGH	0v/Off	0v/Off	MIN POS	Closed
		ON	OFF	HIGH	0v/Off	0v/Off	MIN POS to Full Open	Closed to Full-Open
		ON	ON	HIGH	24v/On	0v/Off*	MIN POS to Full Open	Closed to Full-Open

*With stage 3 delay (STG3 DLY) in Advanced setup menu can turn on second stage of mechanical cooling Y2-O after the delay if the call for Y1-I and Y2-I have not been satisfied.

Table 16 — Dry Bulb Operation with DCV (CO₂ Sensor) — 1 Speed Fan

DEMAND CONTROLLED VENTILATION (DCV)	OUTSIDE AIR GOOD TO ECONOMIZE	Y1-I	Y2-I	FAN SPEED	Y1-O	Y2-O	OCCUPIED	UNOCCUPIED
Below CO ₂ Set	No	OFF	OFF	HIGH	0v/Off	0v/Off	VENTMIN	Closed
		ON	OFF	HIGH	24v/On	0v/Off	VENTMIN	Closed
		ON	ON	HIGH	24v/On	24v/On	VENTMIN	Closed
	Yes	OFF	OFF	HIGH	0v/Off	0v/Off	VENTMIN	Closed
		ON	OFF	HIGH	0v/Off	0v/Off	VENTMIN to Full-Open	Closed to Full-Open
		ON	ON	HIGH	24v/On	0v/Off	VENTMIN to Full-Open	Closed to Full-Open
Above CO ₂ Set	No	OFF	OFF	HIGH	0v/Off	0v/Off	VENTMIN to VENTMAX	Closed
		ON	OFF	HIGH	24v/On	0v/Off	VENTMIN to VENTMAX	Closed
		ON	ON	HIGH	24v/On	24v/On	VENTMIN to VENTMAX	Closed
	Yes	OFF	OFF	HIGH	0v/Off	0v/Off	VENTMIN to VENTMAX	Closed
		ON	OFF	HIGH	0v/Off	0v/Off	VENTMIN to Full-Open	Closed to Full-Open
		ON	ON	HIGH	24v/On	0v/Off*	VENTMIN to Full-Open	Closed to Full-Open

*With stage 3 delay (STG3 DLY) in Advanced setup menu can turn on second stage of mechanical cooling Y2-O after the delay if the call for Y1-I and Y2-I have not been satisfied.

Table 17 — Enthalpy Operation No DCV (CO₂ Sensor) — 1 Speed Fan

DEMAND CONTROLLED VENTILATION (DCV)	OUTSIDE AIR GOOD TO ECONOMIZE	Y1-I	Y2-I	FAN SPEED	Y1-O	Y2-O	OCCUPIED	UNOCCUPIED
NONE	NO	OFF	OFF	HIGH	0v/Off	0v/Off	MIN POS	Closed
		ON	OFF	HIGH	24v/On	0v/Off	MIN POS	Closed
		ON	ON	HIGH	24v/On	24v/On	MIN POS	Closed
NONE	YES	OFF	OFF	HIGH	0v/Off	0v/Off	MIN POS	Closed
		ON	OFF	HIGH	0v/Off	0v/Off	MIN POS to Full Open	Closed to Full-Open
		ON	ON	HIGH	24v/On	0v/Off*	MIN POS to Full Open	Closed to Full-Open

*With stage 3 delay (STG3 DLY) in Advanced setup menu can turn on second stage of mechanical cooling Y2-O after the delay if the call for Y1-I and Y2-I have not been satisfied.

Table 18 — Enthalpy Operation with DCV (CO₂ Sensor) — 1 Speed Fan

DEMAND CONTROLLED VENTILATION (DCV)	OUTSIDE AIR GOOD TO ECONOMIZE	Y1-I	Y2-I	FAN SPEED	Y1-O	Y2-O	OCCUPIED	UNOCCUPIED
Below CO ₂ Set	No	OFF	OFF	HIGH	0v/Off	0v/Off	VENTMIN	Closed
		ON	OFF	HIGH	24v/On	0v/Off	VENTMIN	Closed
		ON	ON	HIGH	24v/On	24v/On	VENTMIN	Closed
	Yes	OFF	OFF	HIGH	0v/Off	0v/Off	VENTMIN	Closed
		ON	OFF	HIGH	0v/Off	0v/Off	VENTMIN to Full-Open	Closed to Full-Open
		ON	ON	HIGH	24v/On	0v/Off	VENTMIN to Full-Open	Closed to Full-Open
Above CO ₂ Set	No	OFF	OFF	HIGH	0v/Off	0v/Off	VENTMIN to VENTMAX	Closed
		ON	OFF	HIGH	24v/On	0v/Off	VENTMIN to VENTMAX	Closed
		ON	ON	HIGH	24v/On	24v/On	VENTMIN to VENTMAX	Closed
	Yes	OFF	OFF	HIGH	0v/Off	0v/Off	VENTMIN to VENTMAX	Closed
		ON	OFF	HIGH	0v/Off	0v/Off	VENTMIN to Full-Open	Closed to Full-Open
		ON	ON	HIGH	24v/On	0v/Off*	VENTMIN to Full-Open	Closed to Full-Open

*With stage 3 delay (STG3 DLY) in Advanced setup menu can turn on second stage of mechanical cooling Y2-O after the delay if the call for Y1-I and Y2-I have not been satisfied.

Table 19 — Dry Bulb Operation No DCV (CO₂ Sensor) — 2 Speed Fan

DEMAND CONTROLLED VENTILATION (DCV)	OUTSIDE AIR GOOD TO ECONOMIZE	Y1-I	Y2-I	FAN SPEED	Y1-O	Y2-O	OCCUPIED	UNOCCUPIED
NONE	NO	OFF	OFF	LOW	0v/Off	0v/Off	MIN POS	Closed
		ON	OFF	LOW	24v/On	0v/Off	MIN POS	Closed
		ON	ON	HIGH	24v/On	24v/On	MIN POS	Closed
NONE	YES	OFF	OFF	LOW	0v/Off	0v/Off	MIN POS	Closed
		ON	OFF	LOW	0v/Off	0v/Off	MIN POS to Full Open	Closed to Full-Open
		ON	ON	HIGH	24v/On	0v/Off*	MIN POS to Full Open	Closed to Full-Open

*With stage 3 delay (STG3 DLY) in Advanced setup menu can turn on second stage of mechanical cooling Y2-O after the delay if the call for Y1-I and Y2-I have not been satisfied.

Table 20 — Dry Bulb Operation with DCV (CO₂ Sensor) — 2 Speed Fan

DEMAND CONTROLLED VENTILATION (DCV)	OUTSIDE AIR GOOD TO ECONOMIZE	Y1-I	Y2-I	FAN SPEED	Y1-O	Y2-O	OCCUPIED	UNOCCUPIED
Below CO ₂ Set	No	OFF	OFF	LOW	0v/Off	0v/Off	VENTMIN	Closed
		ON	OFF	LOW	24v/On	0v/Off	VENTMIN	Closed
		ON	ON	HIGH	24v/On	24v/On	VENTMIN	Closed
	Yes	OFF	OFF	LOW	0v/Off	0v/Off	VENTMIN	Closed
		ON	OFF	LOW	0v/Off	0v/Off	VENTMIN to Full-Open	Closed to Full-Open
		ON	ON	HIGH	24v/On	0v/Off	VENTMIN to Full-Open	Closed to Full-Open
Above CO ₂ Set	No	OFF	OFF	LOW	0v/Off	0v/Off	VENTMIN to VENTMAX	Closed
		ON	OFF	LOW	24v/On	0v/Off	VENTMIN to VENTMAX	Closed
		ON	ON	HIGH	24v/On	24v/On	VENTMIN to VENTMAX	Closed
	Yes	OFF	OFF	LOW	0v/Off	0v/Off	VENTMIN to VENTMAX	Closed
		ON	OFF	LOW	0v/Off	0v/Off	VENTMIN to Full-Open	Closed to Full-Open
		ON	ON	HIGH	24v/On	0v/Off*	VENTMIN to Full-Open	Closed to Full-Open

*With stage 3 delay (STG3 DLY) in Advanced setup menu can turn on second stage of mechanical cooling Y2-O after the delay if the call for Y1-I and Y2-I have not been satisfied.

Table 21 — Enthalpy Operation No DCV (CO₂ Sensor) — 2 Speed Fan

DEMAND CONTROLLED VENTILATION (DCV)	OUTSIDE AIR GOOD TO ECONOMIZE	Y1-I	Y2-I	FAN SPEED	Y1-O	Y2-O	OCCUPIED	UNOCCUPIED
NO CO ₂ SENSOR	NO	OFF	OFF	LOW	0v/Off	0v/Off	MIN POS	Closed
		ON	OFF	LOW	24v/On	0v/Off	MIN POS	Closed
		ON	ON	HIGH	24v/On	24v/On	MIN POS	Closed
	YES	OFF	OFF	LOW	0v/Off	0v/Off	MIN POS	Closed
		ON	OFF	LOW	0v/Off	0v/Off	MIN POS to Full Open	Closed to Full-Open
		ON	ON	HIGH	24v/On	0v/Off*	MIN POS to Full Open	Closed to Full-Open

*With stage 3 delay (STG3 DLY) in Advanced setup menu can turn on second stage of mechanical cooling Y2-O after the delay if the call for Y1-I and Y2-I have not been satisfied.

Table 22 — Enthalpy Operation with DCV (CO₂ Sensor) — 2 Speed Fan

DEMAND CONTROLLED VENTILATION (DCV)	OUTSIDE AIR GOOD TO ECONOMIZE	Y1-I	Y2-I	FAN SPEED	Y1-O	Y2-O	OCCUPIED	UNOCCUPIED
Below CO ₂ Set	No	OFF	OFF	LOW	0v/Off	0v/Off	VENTMIN	Closed
		ON	OFF	LOW	24v/On	0v/Off	VENTMIN	Closed
		ON	ON	HIGH	24v/On	24v/On	VENTMIN	Closed
	Yes	OFF	OFF	LOW	0v/Off	0v/Off	VENTMIN	Closed
		ON	OFF	LOW	0v/Off	0v/Off	VENTMIN to Full-Open	Closed to Full-Open
		ON	ON	HIGH	24v/On	0v/Off	VENTMIN to Full-Open	Closed to Full-Open
Above CO ₂ Set	No	OFF	OFF	LOW	0v/Off	0v/Off	VENTMIN to VENTMAX	Closed
		ON	OFF	LOW	24v/On	0v/Off	VENTMIN to VENTMAX	Closed
		ON	ON	HIGH	24v/On	24v/On	VENTMIN to VENTMAX	Closed
	Yes	OFF	OFF	LOW	0v/Off	0v/Off	VENTMIN to VENTMAX	Closed
		ON	OFF	LOW	0v/Off	0v/Off	VENTMIN to Full-Open	Closed to Full-Open
		ON	ON	HIGH	24v/On	0v/Off*	VENTMIN to Full-Open	Closed to Full-Open

*With stage 3 delay (STG3 DLY) in Advanced setup menu can turn on second stage of mechanical cooling Y2-O after the delay if the call for Y1-I and Y2-I have not been satisfied.

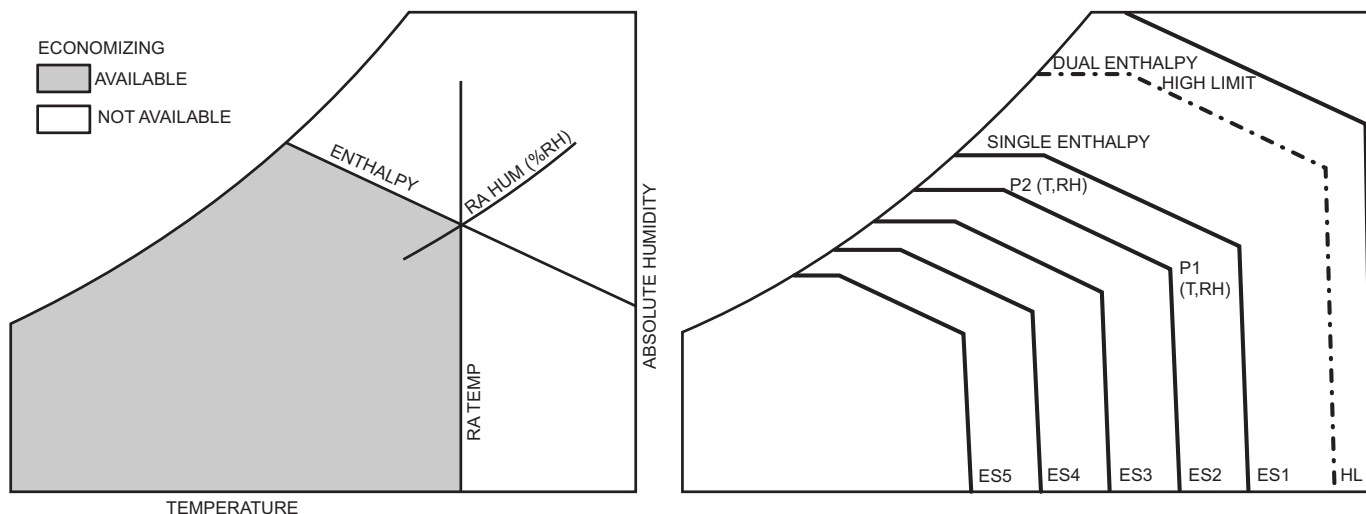

Fig. 42 — Single Enthalpy Curve Boundaries

Table 23 — Single Enthalpy and Dual Enthalpy High Limit Curves

ENTHALPY CURVE	TEMP. DRY BULB (F)	TEMP. DEWPOINT (F)	ENTHALPY (btu/lb/da)	POINT P1		POINT P2	
				TEMP. (F)	HUMIDITY (%RH)	TEMP. (F)	HUMIDITY (%RH)
ES1	80	60	28.0	80	36.8	66.3	80.1
ES2	75	57	26.0	75	39.6	63.3	80.0
ES3	70	54	24.0	70	42.3	59.7	81.4
ES4	65	51	22.0	65	44.8	55.7	84.2
ES5	60	48	20.0	60	46.9	51.3	88.5
HL	86	66	32.4	86	38.9	72.4	80.3

Enthalpy Settings — When the OA temperature, enthalpy and dew point are below the respective setpoints, the outdoor air can be used for economizing. Figure 42 shows the new single enthalpy boundaries in the W7220. There are 5 boundaries (setpoints ES1 through ES5), which are defined by dry bulb temperature, enthalpy and dew point.

Refer to Table 23 for ENTH CURVE setpoint values.

The W7220 calculates the enthalpy and dew point using the OA temperature and humidity input from the OA enthalpy sensor. When the OA temperature, OA humidity and OA dew point are all below the selected boundary, the economizer sets the economizing mode to YES, economizing is available.

When all of the OA conditions are above the selected boundary, the conditions are not good to economize and the mode is set to NO.

Fig. 42 shows the 5 current boundaries. There is also a high limit boundary for differential enthalpy. The high limit boundary is ES1 when there are no stages of mechanical cooling energized and HL (high limit) when a compressor stage is energized.

Table 23 provides the values for each boundary limit.

Two-Speed Fan Operation

NOTE: Two-Speed Fan operation does not apply to 48TC 04-06 units.

The W7220 controller has the capability to work with a system using a 2-speed supply fan. The W7220 does not control the supply directly but uses the following input status to

determine the speed of the supply fan and controls the OA damper to the required position, see Table 24.

Table 24 — Fan Speed

STATE	FAN SPEED
OCC	Low
Y1	Low
Y2	High
W	High

The W (heating mode) is not controlled by the W7220 but it requires the status to know where to position the OA damper for minimum position for the fan speed.

The 2 speed fan delay is available when the system is programmed for 2 speed fan (in the System Setup menu item). The 2 speed fan delay is defaulted to 5 minutes and can be changed in the Advanced Setup menu item. When the unit has a call for Y1 In and in the free cooling mode and there is a call for Y2 In, the 2-speed fan delay starts and the OA damper will modulate 100% open, the supply fan should be set to high speed by the unit controller.

After the delay one of two actions will happen:

- The Y2-In call will be satisfied with the damper 100% open and fan on high speed and the call will turn off OR
- If the call for additional cooling in the space has not been satisfied then the first stage of mechanical cooling will be enabled through Y1 Out or Y2 Out.

Checkout

Inspect all wiring connections at the Economizer module's terminals, and verify compliance with the installation wiring diagrams.

For checkout, review the Status of each configured parameter and perform the Checkout tests.

NOTE: See Interface Overview on page 25 for information about menu navigation and use of the keypad.

WARNING

Failure to follow this warning could result in personal injury, property damage, or death.

Before performing service or maintenance operations on unit, always turn off main power switch to unit and install lock(s) and lockout tag(s). Unit may have more than one power switch. Ensure electrical service to rooftop unit agrees with voltage and amperage listed on the unit rating plate.

If any wiring changes are required, first be sure to remove power from the economizer module before starting work. Pay particular attention to verifying the power connection (24 Vac).

Power Up — After the W7220 module is mounted and wired, apply power.

Initial Menu Display — On initial start up, Honeywell displays on the first line and Economizer W7220 on the second line. After a brief pause, the revision of the software appears on the first line and the second line will be blank.

Power Loss (Outage or Brownout) — All setpoints and advanced settings are restored after any power loss or interruption.

NOTE: All settings are stored in non-volatile flash memory.

Status — Use the Status menu (see Table 13) to check the parameter values for the various devices and sensors configured.

NOTE: See Interface Overview on page 25 for information about menu navigation and use of the keypad.

Checkout Tests — Use the Checkout menu (on page 30) to test the damper operation and any configured outputs. Only items that are configured are shown in the Checkout menu.

NOTE: See Interface Overview on page 25 for information about menu navigation and use of the keypad.

To perform a Checkout test:

1. Scroll to the desired test in the Checkout menu using the ▲ and ▼ buttons.

2. Press the ← button to select the item.
3. RUN? appears.
4. Press the ← button to start the test.
5. The unit pauses and then displays IN PROGRESS.
6. When the test is complete, DONE appears.
7. When all desired parameters have been tested, press the ⬆ (Menu Up) button to end the test.

The Checkout tests can all be performed at the time of installation or at any time during the operation of the system as a test that the system is operable.

Troubleshooting

Alarms — The Economizer module provides alarm messages that display on the 2-line LCD.

NOTE: Upon power up, the module waits 60 minutes before checking for alarms. This allows time for all the configured devices (e.g. sensors, actuator) to become operational. The exception is the SAT sensor which will alarm immediately.

If one or more alarms are present and there has been no keypad activity for at least 5 minutes, the Alarms menu displays and cycles through the active alarms.

You can also navigate to the Alarms menu at any time.

Clearing Alarms — Once the alarm has been identified and the cause has been removed (e.g. replaced faulty sensor), the alarm can be cleared from the display.

To clear an alarm, perform the following:

1. Navigate to the desired alarm.
2. Press the button.
3. ERASE? displays.
4. Press the button.
5. ALARM ERASED displays.
6. Press the (Menu up/Exit) button to complete the action and return to the previous menu.

NOTE: If the alarm still exists after you clear it, it is redisplayed within 5 seconds.

CAUTION

Failure to follow this caution may result in damage to equipment. Be sure to allow enough time for compressor startup and shutdown between checkout tests so that you do not short-cycle the compressors.

PREMIERLINK™ (FACTORY-OPTION) — The PremierLink controller (see Fig. 43) is compatible with Carrier Comfort Network® (CCN) devices. This control is designed to allow users the access and ability to change factory-defined settings, thus expanding the function of the standard unit control board. CCN service access tools include System Pilot™, Touch Pilot™ and Service Tool. (Standard tier display tools Navigator and Scrolling Marquee are not suitable for use with latest PremierLink controller (Version 2.x).)

The PremierLink control is factory-mounted in the 48TC unit's main control box to the left of the Central Terminal Board (CTB) (see Fig. 44). Factory wiring is completed through harnesses connected to the CTB thermostat. Field connections are made at a 16-pole terminal block (TB1) located on the bottom shelf of the unit control box in front of the PremierLink controller. The factory-installed PremierLink control

includes the supply-air temperature (SAT) sensor. The outdoor air temperature (OAT) sensor is included in the FIOP/accessory EconoMiSer2 package.

The PremierLink controller requires the use of a Carrier electronic thermostat or a CCN connection for time broadcast to initiate its internal time-clock. This is necessary for broadcast of time of day functions (occupied/unoccupied).

NOTE: PremierLink controller is shipped in Sensor mode. To be used with a thermostat, the PremierLink controller must be configured to Thermostat mode. Refer to PremierLink Configuration instructions for Operating Mode.

See Fig. 45 for typical PremierLink wiring. See Fig. 46 for typical PremierLink wiring when the 48TC unit is equipped with a Humidi-MiZer® system.

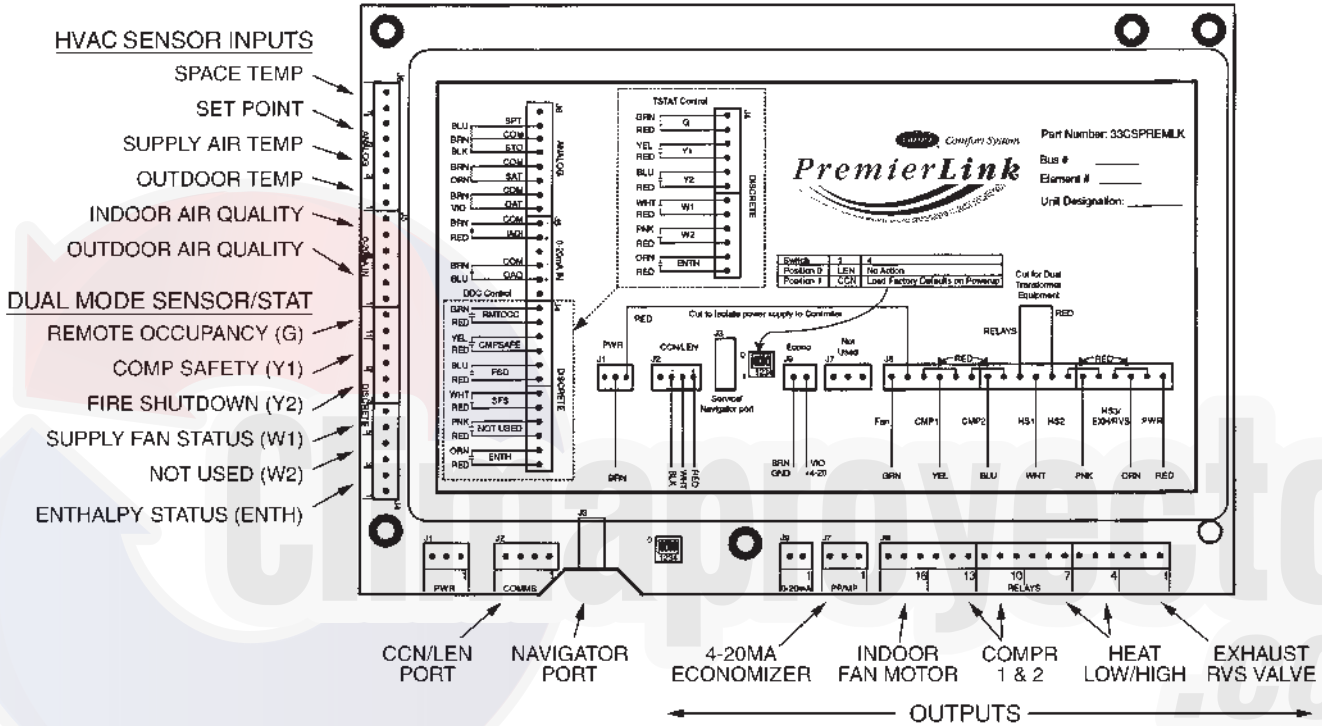

Fig. 43 — PremierLink Controller

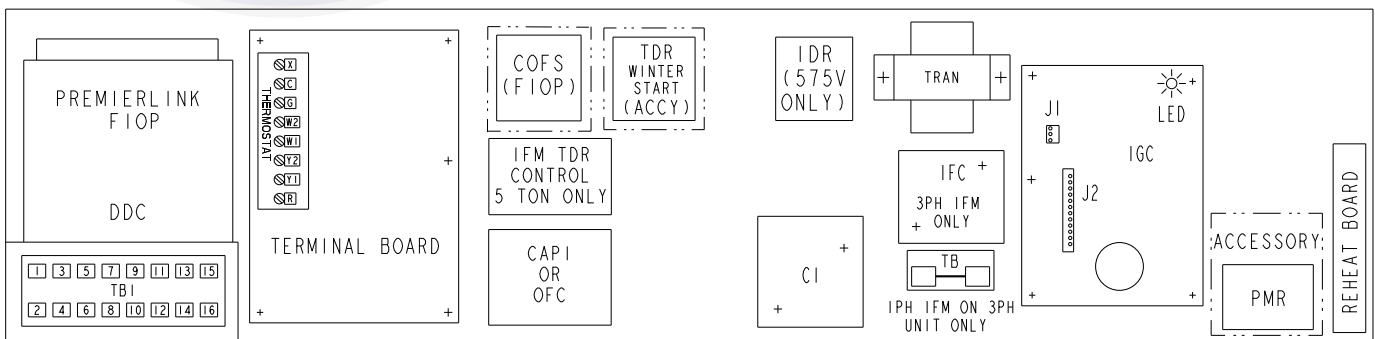

Fig. 44 — 48TC Control Box — PremierLink Location

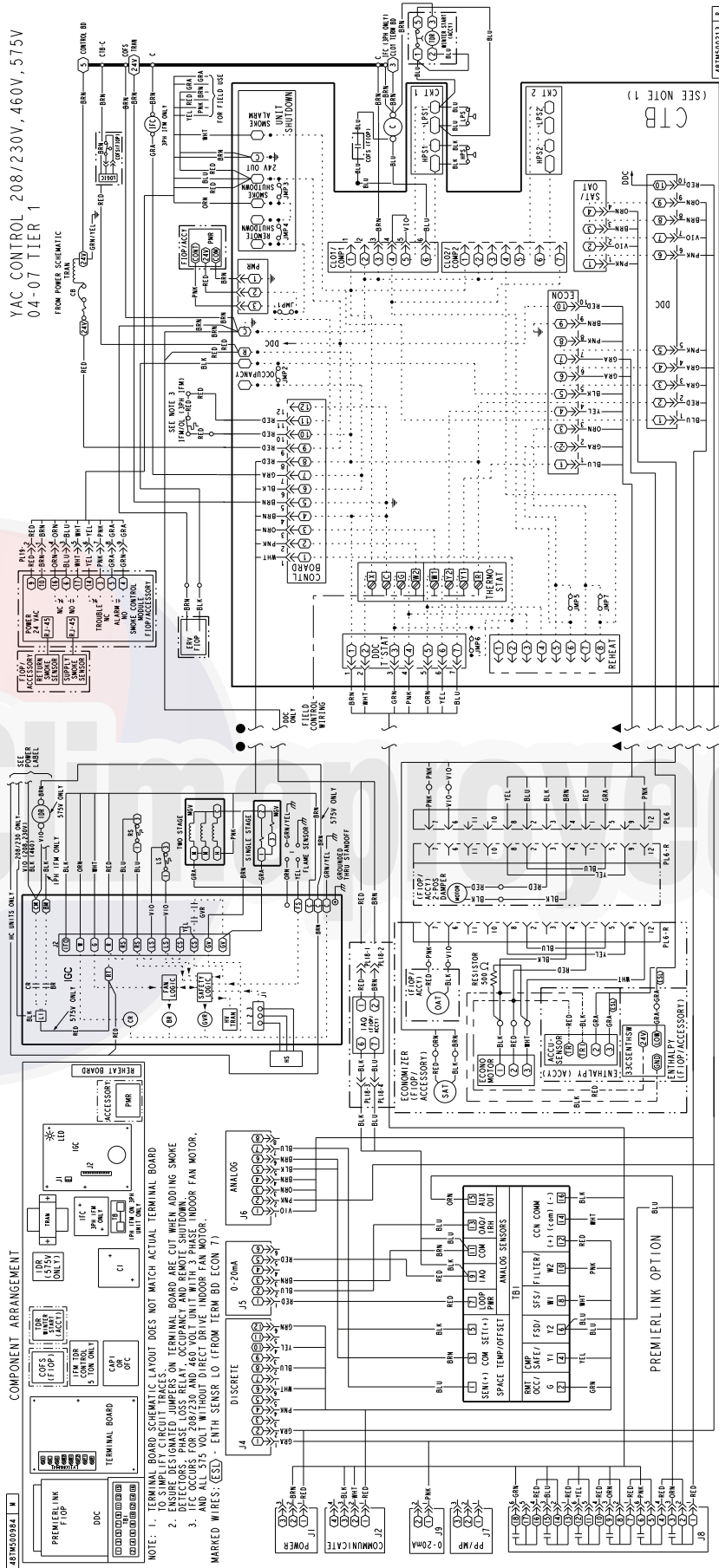

Fig. 45 — PremierLink Wiring Schematic

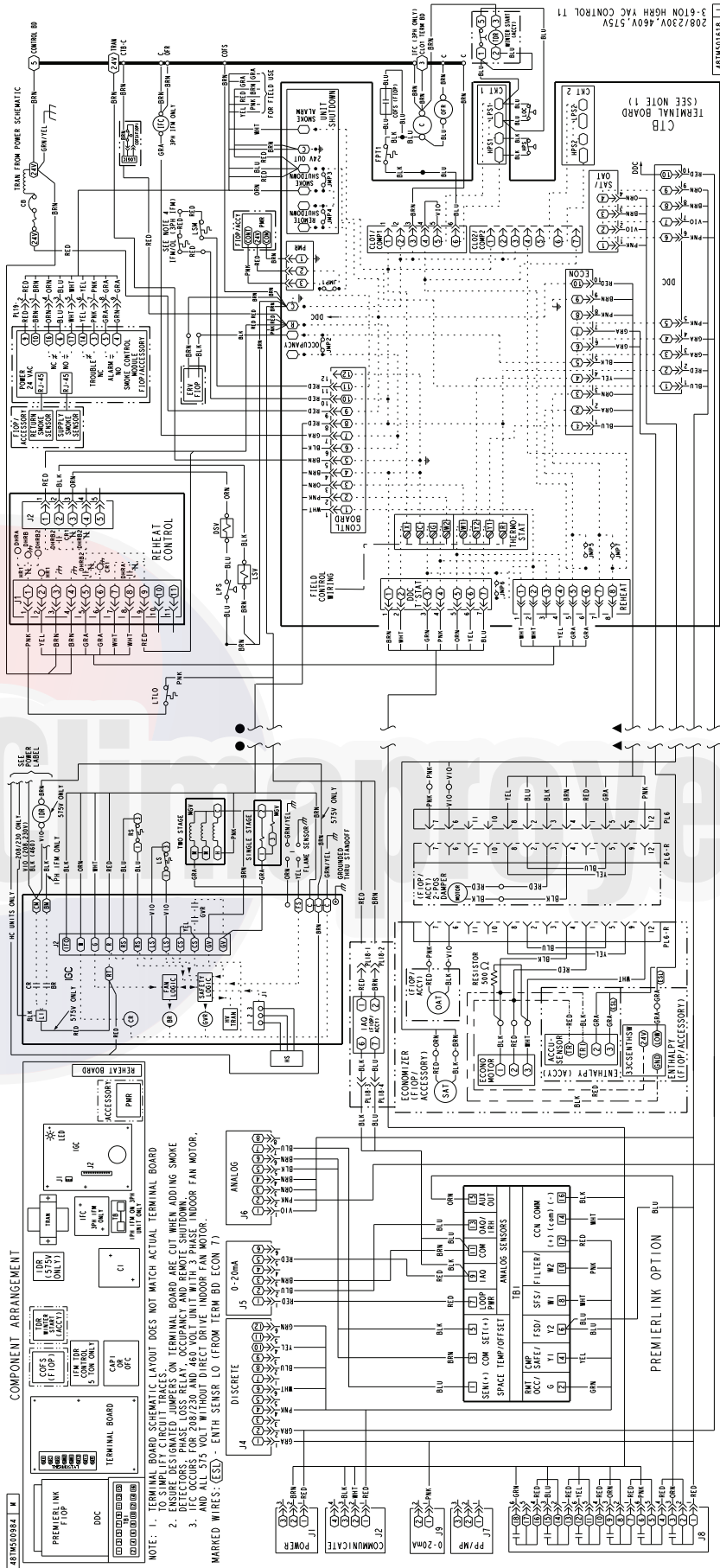

Fig. 46 — PremierLink Wiring Schematic with Humidi-MiZer® System

Supply Air Temperature (SAT) Sensor — On FIOP-equipped 48TC unit, the unit is supplied with a supply-air temperature (SAT) sensor (33ZCESENSAT). This sensor is a tubular probe type, approx 6-inches (152 mm) in length. It is a nominal 10-k ohm thermistor. The SAT is factory-wired.

The SAT probe is wire-tied to the supply-air opening (on the horizontal opening end) in its shipping position. Remove the sensor for installation. Re-position the sensor in the flange of the supply-air opening or in the supply air duct (as required by local codes), see Fig. 47. Drill or punch a 1/2-in. hole in the flange or duct. Use two field-supplied, self-drilling screws to secure the sensor probe in a horizontal orientation.

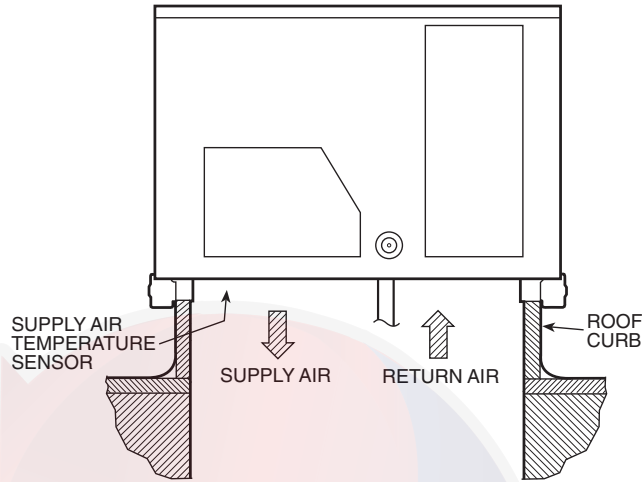

Fig. 47 — Typical Mounting Location for Supply Air Temperature (SAT) Sensor on Small Rooftop Units

NOTE: Refer to PremierLink Installation, Start-up, and Configuration Instructions for complete PremierLink configuration, operating sequences and troubleshooting

information. Have a copy of this manual available at unit start-up.

NOTE: The sensor must be mounted in the discharge air-stream downstream of the cooling coil and any heating devices. Be sure the probe tip does not come in contact with any of the unit's heater surfaces.

Outdoor Air Temperature (OAT) Sensor — The OAT is factory-mounted in the EconoMiSer2 (FIOP or accessory) system. It is a nominal 10k ohm thermistor attached to an eyelet mounting ring.

EconoMiSer2 — The PremierLink control is used with the EconoMiSer2 (option or accessory) system for outdoor air management. The damper position is controlled directly by the PremierLink control; The EconoMiSer2 system has no internal logic device.

Outdoor air management functions can be enhanced with field-installation of these accessory control devices:

- Enthalpy control (outdoor air or differential sensors)
- Space CO₂ sensor
- Outdoor air CO₂ sensor

Refer to Table 25 for accessory part numbers.

PREMIERLINK FIELD CONNECTIONS — Field connections for accessory sensor and input devices are made at the 16-pole terminal block (TB1) located on the control box bottom shelf in front of the PremierLink control (see Fig. 45 and 46). Some input devices also require a 24-vac signal source; connect at CTB terminal R at "THERMOSTAT" connection strip for this signal source. See connections figures on following pages for field connection locations (and for continued connections at the PremierLink board inputs).

Table 26 provides a summary of field connections for units equipped with Space Sensor. Table 27 provides a summary of field connections for units equipped with Space Thermostat.

Table 25 — PremierLink™ Sensor Usage

APPLICATION	OUTDOOR AIR TEMPERATURE SENSOR	RETURN AIR TEMPERATURE SENSOR	OUTDOOR AIR ENTHALPY SENSOR	RETURN AIR ENTHALPY SENSOR
Differential Dry Bulb Temperature with PremierLink (PremierLink requires 4-20 mA Actuator)	Included — CRTEMPSN001A00	Required — 33ZCT55SPT or equivalent	—	—
Single Enthalpy with PremierLink (PremierLink requires 4-20 mA Actuator)	Included — Not Used	—	Requires — 33CSENTHSW	—
Differential Enthalpy with PremierLink (PremierLink requires 4-20 mA Actuator)	Included — Not Used	—	Requires — 33CSENTHSW or equivalent	Requires — 33CSENTSEN or equivalent

NOTE: CO₂ Sensors (Optional):

33ZCSENCO2 — Room sensor (adjustable). Aspirator box is required for duct mounting of the sensor.

33ZCASPCO2 — Aspirator box used for duct-mounted CO₂ room sensor.

33ZCT55CO2 — Space temperature and CO₂ room sensor with override.

33ZCT56CO2 — Space temperature and CO₂ room sensor with override and setpoint.

Table 26 — Space Sensor Mode

TB1 TERMINAL	FIELD CONNECTION	INPUT SIGNAL
1	T55-SEN/T56-SEN	Analog (10k thermistor)
2	RMT OCC	Discrete, 24VAC
3	T55-SEN/T56-SEN	Analog (10k thermistor)
4	CMPSAFE	Discrete, 24VAC
5	T56-SET	Analog (10k thermistor)
6	FSD	Discrete, 24VAC
7	LOOP-PWR	Analog, 24VDC
8	SPS	Discrete, 24VAC
9	IAQ-SEN	Analog, 4-20mA
10	FILTER	Discrete, 24VAC
11	IAQ-COM/OAQ-COM/RH-COM	Analog, 4-20mA
12	CCN + (RED)	Digital, 5VDC
13	OAQ-SEN/RH-SEN	Analog, 4-20mA
14	CCN Gnd (WHT)	Digital, 5VDC
15	AUX OUT (Power Exhaust)	(Output) Discrete 24VAC
16	CCN - (BLK)	Digital, 5VDC

LEGEND

- | | | | |
|----------------|--|------------|--|
| T55 | — Space Temperature Sensor | FSD | — Fire Shutdown |
| T56 | — Space Temperature Sensor | IAQ | — Indoor Air Quality (CO ₂) |
| CCN | — Carrier Comfort Network® (communication bus) | OAQ | — Outdoor Air Quality (CO ₂) |
| CMPSAFE | — Compressor Safety | RH | — Relative Humidity |
| FILTER | — Dirty Filter Switch | SFS | — Supply Fan Status |

Table 27 — Thermostat Mode

TB1 TERMINAL	FIELD CONNECTION	INPUT SIGNAL
1	RAT SEN	Analog (10k thermistor)
2	G	Discrete, 24VAC
3	RAT SEN	Analog (10k thermistor)
4	Y1	Discrete, 24VAC
5	—	—
6	Y2	Discrete, 24VAC
7	LOOP-PWR	Analog, 24VDC
8	W1	Discrete, 24VAC
9	IAQ-SEN	Analog, 4-20mA
10	W2	Discrete, 24VAC
11	IAQ-COM/OAQ-COM/RH-COM	Analog, 4-20mA
12	CCN + (RED)	Digital, 5VDC
13	OAQ-SEN/RH-SEN	Analog, 4-20mA
14	CCN Gnd (WHT)	Digital, 5VDC
15	AUX OUT (Power Exhaust)	(Output) Discrete 24VAC
16	CCN - (BLK)	Digital, 5VDC

LEGEND

- | | | | |
|----------------|--|------------|--|
| T55 | — Space Temperature Sensor | FSD | — Fire Shutdown |
| T56 | — Space Temperature Sensor | IAQ | — Indoor Air Quality (CO ₂) |
| CCN | — Carrier Comfort Network® (communication bus) | OAQ | — Outdoor Air Quality (CO ₂) |
| CMPSAFE | — Compressor Safety | RH | — Relative Humidity |
| FILTER | — Dirty Filter Switch | SFS | — Supply Fan Status |

Space Sensors — The PremierLink controller is factory-shipped configured for Space Sensor Mode. A Carrier T-55 or T-56 space sensor must be used. T-55 space temperature sensor provides a signal of space temperature to the PremierLink control. T-56 provides same space temperature signal plus it allows for adjustment of space temperature setpoints from the face of the sensor by the occupants, see Fig. 48.

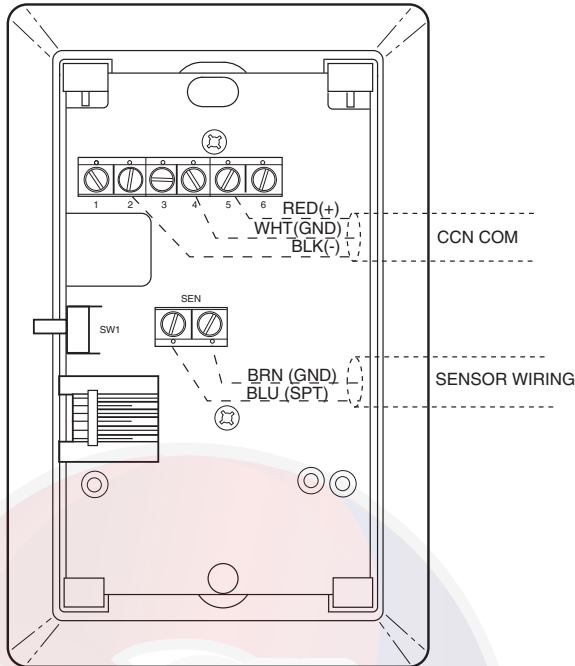

Fig. 48 — T-55 Space Temperature Sensor Wiring

Connect T-55 — See Fig. 49 for typical T-55 internal connections. Connect the T-55 SEN terminals to TB1 terminals 1 and 3 (see Fig. 49).

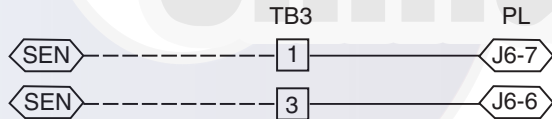

Fig. 49 — PremierLink T-55 Sensor

Connect T-56 — See Fig. 50 for T-56 internal connections. Install a jumper between SEN and SET terminals as illustrated. Connect T-56 terminals to TB1 terminals 1, 3, and 5 (see Fig. 51).

Connect Thermostat — A 7-wire thermostat connection requires a 24-v power source and a common connection. Use the R and C terminals on the CTB's THERMOSTAT connection strip for these. Connect the thermostat's Y1, Y2, W1, W2 and G terminals to PremierLink TB1 as shown in Fig. 52.

If the 48TC unit is equipped with factory-installed smoke detector(s), disconnect the factory BLU lead at TB1-6 (Y2) before connecting the thermostat. Identify the BLU lead originating at CTB-DDC-1; disconnect at TB1-6 and tape off. Confirm that the second BLU lead at TB1-6 remains connected to PremierLink J4-8.

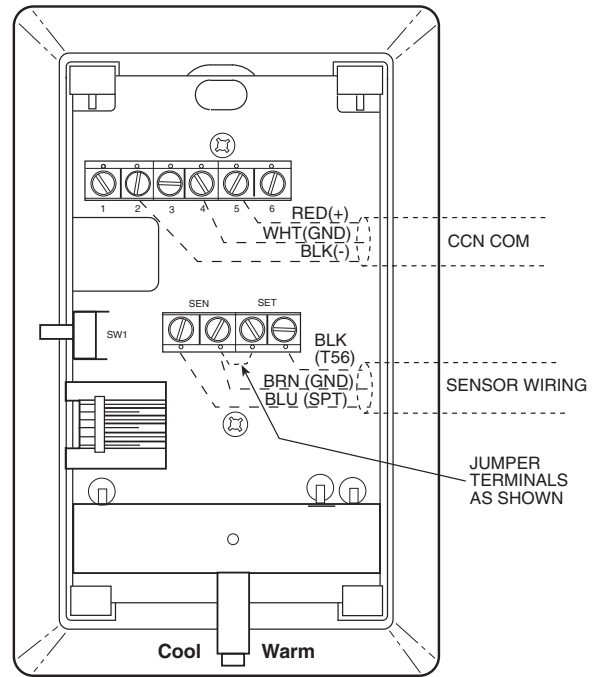

Fig. 50 — T-56 Internal Connections

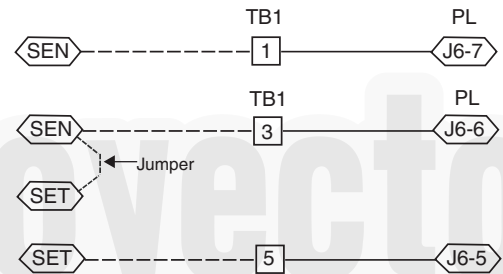

Fig. 51 — PremierLink T-56 Sensor

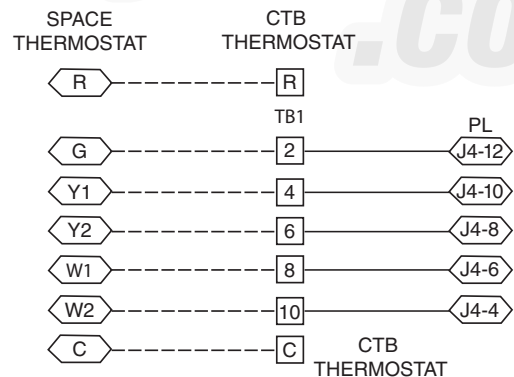

Fig. 52 — Space Thermostat Connections

If the 48TC unit has an economizer system and free-cooling operation is required, a sensor representing Return Air Temperature must also be connected (field-supplied and installed). This sensor may be a T-55 Space Sensor (see Fig. 48) installed in the space or in the return duct, or it may be sensor PNO 33ZCSENSAT, installed in the return duct. Connect this sensor to TB1-1 and TB1-3 per Fig. 49.

Configure the Unit for Thermostat Mode — Connect to the CCN bus using a CCN service tool and navigate to PremierLink Configuration screen for Operating Mode. Default setting is Sensor Mode (value 1). Change the value to 0 to reconfigure the controller for Thermostat Mode.

When the PremierLink is configured for Thermostat Mode, these functions are not available: Fire Shutdown (FSD), Remote Occupied (RMTOCC), Compressor Safety (CMPSAFE), Supply Fan Status (SFS), and Filter Pressure Switch (FILTER).

ECONOMIZER CONTROLS

Indoor Air Quality (CO₂) Sensor — The indoor air quality sensor accessory monitors space carbon dioxide (CO₂) levels. This information is used to monitor IAQ levels. Several types of sensors are available, for wall mounting in the space or in return duct, with and without LCD display, and in combination with space temperature sensors. Sensors use infrared technology to measure the levels of CO₂ present in the space air.

The CO₂ sensors are all factory set for a range of 0 to 2000 ppm and a linear mA output of 4 to 20. Refer to the instructions supplied with the CO₂ sensor for electrical requirements and terminal locations. See Fig. 53 for typical CO₂ sensor wiring schematic.

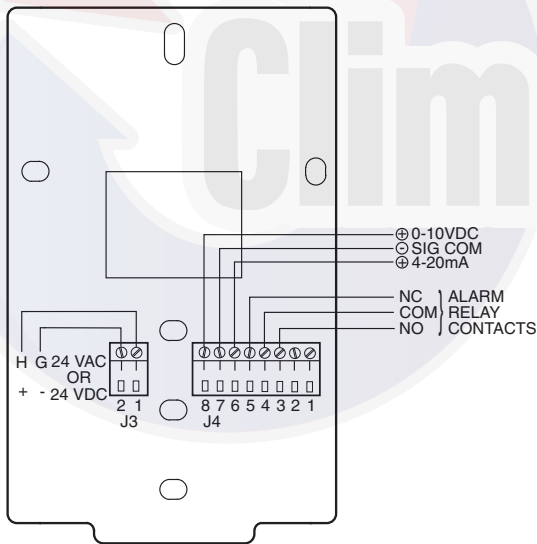

Fig. 53 — Indoor/Outdoor Air Quality (CO₂) Sensor (33ZCSENCO2) — Typical Wiring Diagram

To accurately monitor the quality of the air in the conditioned air space, locate the sensor near a return-air grille (if present) so it senses the concentration of CO₂ leaving the space. The sensor should be mounted in a location to avoid direct breath contact.

Do not mount the IAQ sensor in drafty areas such as near supply ducts, open windows, fans, or over heat sources. Allow at least 3 ft (0.9 m) between the sensor and any corner. Avoid mounting the sensor where it is influenced by the supply air; the sensor gives inaccurate readings if the supply air is blown directly onto the sensor or if the supply air does not have a chance to mix with the room air before it is drawn into the return airstream.

Wiring the Indoor Air Quality Sensor — For each sensor, use two 2-conductor 18 AWG (American Wire Gage) twisted-pair cables (unshielded) to connect the separate isolated 24 vac power source to the sensor and to connect the sensor to the control board terminals.

To connect the sensor to the control, identify the positive (4 to 20 mA) and ground (SIG COM) terminals on the sensor. See Fig. 48. Connect the 4-20 mA terminal to terminal TB1-9 and connect the SIG COM terminal to terminal TB1-11. See Fig. 54.

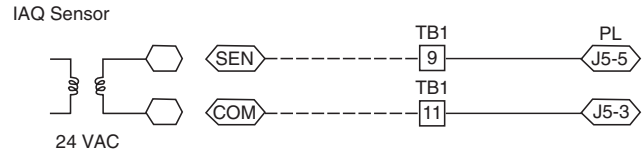

Fig. 54 — Indoor CO₂ Sensor (33ZCSENCO2) Connections

Refer to PremierLink Installation, Start-up, and Configuration Instructions, for detailed configuration information.

Outdoor Air Quality Sensor (P/N: 33ZCSENCO₂ Plus Weatherproof Enclosure) — The outdoor air CO₂ sensor is designed to monitor carbon dioxide (CO₂) levels in the outside ventilation air and interface with the ventilation damper in an HVAC system. The OAQ sensor is packaged with an outdoor cover. See Fig. 55. The outdoor air CO₂ sensor must be located in the economizer outside air hood.

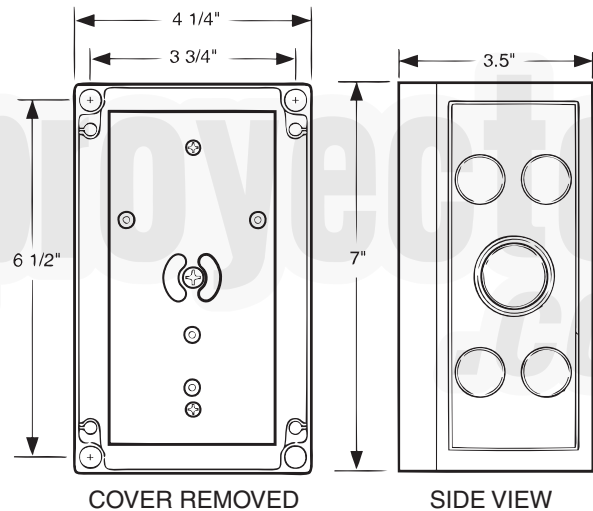

Fig. 55 — Outdoor Air Quality Sensor Cover

Wiring the Outdoor Air CO₂ Sensor — A dedicated power supply is required for this sensor. A two-wire cable is required to wire the dedicated power supply for the sensor. The two wires should be connected to the power supply and terminals 1 and 2.

To connect the sensor to the control, identify the positive (4 to 20 mA) and ground (SIG COM) terminals on the OAQ sensor. See Fig. 48. Connect the 4 to 20 mA terminal to the TB1-13 terminal of the 48TC. Connect the SIG COM terminal to the TB1-11 terminal of the 48TC unit. See Fig. 56.

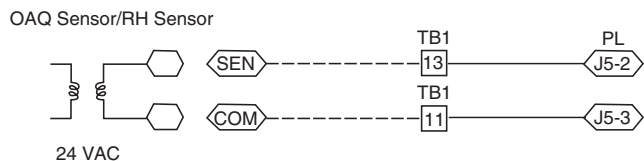

Fig. 56 — Outdoor CO₂ Sensor Connections

NOTE: The accessory space relative humidity sensor and humidistat are not available for single phase (-3 voltage code) models.

Space Relative Humidity Sensor Connections — The accessory space relative humidity sensor (33ZCSENSRH-01) is installed on an interior wall to measure the relative humidity of the air within the occupied space.

The use of a standard 2 X 4 inch electrical box to accommodate the wiring is recommended for installation. The sensor can be mounted directly on the wall, if acceptable by local codes.

CAUTION

Failure to follow this caution may result in permanent damage to the sensor.

DO NOT clean or touch the sensing element with chemical solvents as they can permanently damage the sensor.

CAUTION

Failure to follow this caution will result in inaccurate sensor readings.

DO NOT mount the sensor in drafty areas such as near heating or air-conditioning ducts, open windows, fans, or over heat sources such as baseboard heaters, radiators, or wall-mounted dimmers. Sensors mounted in those areas will produce inaccurate readings.

If the sensor is installed directly on a wall service, install the humidity sensor using 2 screws and 2 hollow wall anchors (field supplied). Do not over tighten screws. See Fig. 57.

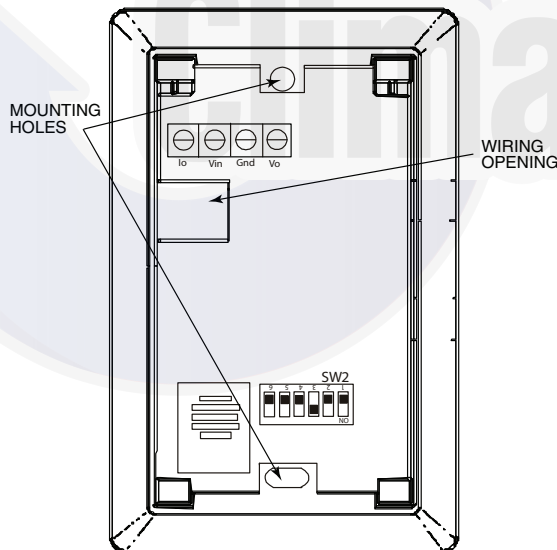

Fig. 57 — Space Relative Humidity Sensor Installation

The sensor must be mounted vertically on the wall. The Carrier logo should be orientated correctly when the sensor is properly mounted.

Avoid corner locations. Allow at least 4 ft between the sensor and any corner. Airflow near corners tends to be reduced, resulting in erratic sensor readings. The sensor should be vertically mounted approximately 5 ft up from the floor, beside the space temperature sensor.

For wiring distances up to 500 feet, use a 3-conductor, 18 or 20 AWG cable. A CCN communication cable can be used,

although the shield is not required. The shield must be removed from the sensor end of the cable if this cable is used. See Fig. 58 for wiring details.

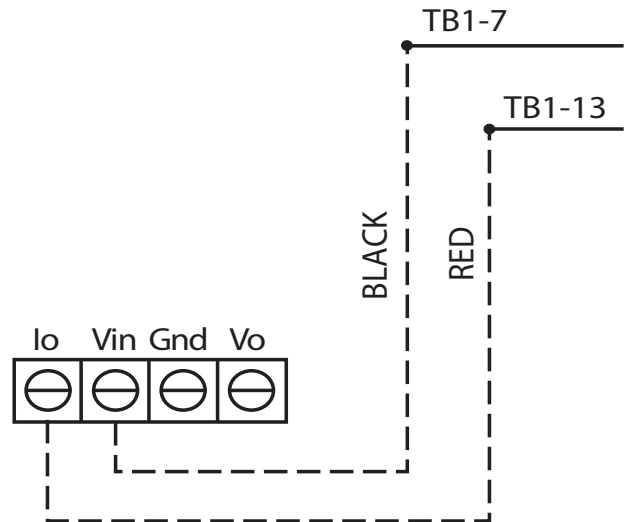

Fig. 58 — Space Relative Humidity Sensor Connection

The power for the sensor is provided by the PremierLink control on terminal J5-4 (+33 to +35vdc).

To Wire the Sensor

1. At the sensor, remove 4 inches of the jacket from the cable. Strip ¼ inch of insulation from each conductor. Route the cable through the wire clearance opening in the center of the sensor. See Fig. 57.
2. Connect a field-supplied BLACK wire to the sensor screw terminal marked Vin.
3. Connect a field-supplied RED wire into the sensor screw terminal marked Io.
4. Connect the field-supplied RED wire from the sensor to TB1-13.
5. Connect the field-supplied BLACK wire from the sensor to TB1-7.

Smoke Detector/Fire Shutdown (FSD) — This function is available only when PremierLink is configured for (Space) Sensor Mode. The unit is factory-wired for PremierLink FSD operation when PremierLink is factory-installed.

On 48TC units equipped with factory-installed Smoke Detector(s), the smoke detector controller implements the unit shutdown through its NC contact set connected to the unit's CTB input. The FSD function is initiated via the smoke detector's Alarm NO contact set. The PremierLink communicates the smoke detector's tripped status to the CCN building control. See Fig. 40 and 41, PremierLink wiring schematics.

Filter Status Switch — This function is available only when PremierLink is configured for (Space) Sensor Mode.

PremierLink control can monitor return filter status in two ways: By monitoring a field-supplied/installed filter pressure switch or via supply fan runtime hours.

Using switch input: Install the dirty filter pressure switch according to switch manufacturer's instructions, to measure pressure drop across the unit's return filters. Connect one side of the switch's NO contact set to CTB's THERMOSTAT-R terminal. Connect the other side of the NO contact set to TB1-10. Setpoint for Dirty Filter is set at the switch. See Fig. 59.

Filter Switch (NO, close on rising pressure (high drop))

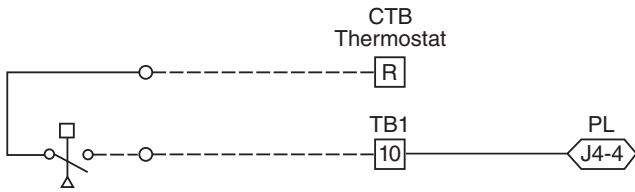

Fig. 59 — PremierLink Filter Switch Connection

When the filter switch's NO contact set closes as filter pressure drop increases (indicating dirt-laden filters), the input signal to PremierLink causes the filter status point to read "DIRTY".

Using Filter Timer Hours — Refer to PremierLink Installation, Start-up, and Configuration Instructions for instructions on using the PremierLink Configuration screens and on unit alarm sequence.

Supply Fan Status Switch — The PremierLink control can monitor supply fan operation through a field-supplied/installed differential pressure switch. This sequence will prevent (or interrupt) operation of unit cooling, heating and economizer functions until the pressure switch contacts are closed indicating proper supply fan operation.

Install the differential pressure switch in the supply fan section according to switch manufacturer's instructions. Arrange the switch contact to be open on no flow and to close as pressure rises indicating fan operation.

Connect one side of the switch's NO contact set to CTB's THERMOSTAT-R terminal. Connect the other side of the NO contact set to TB1-8. Setpoint for Supply Fan Statuses set at the switch. See Fig. 60.

Fan (Pressure) Switch (NO, close on rise in pressure)

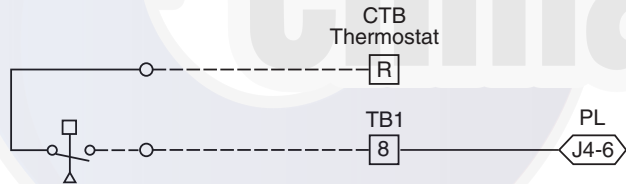

Fig. 60 — PremierLink Wiring Fan Pressure Switch Connection

Remote Occupied Switch — The PremierLink control permits a remote time-clock to override the control's on-board occupancy schedule and place the unit into Occupied mode. This function may also provide a "Door Switch" time delay function that will terminate cooling and heating functions after a 2-20 minute delay.

Connect one side of the NO contact set on the timeclock to CTB's THERMOSTAT-R terminal. Connect the other side of the timeclock contact to the unit's TB1-2 terminal (see Fig. 61).

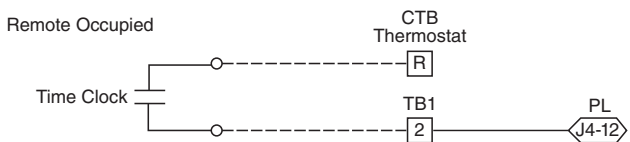

Fig. 61 — PremierLink Wiring Remote Occupied

Refer to PremierLink Installation, Start-up, and Configuration Instructions, for additional information on configuring the PremierLink control for Door Switch timer function.

Power Exhaust (Output) — Connect the accessory Power Exhaust contactor coil(s) per Fig. 62.

Power Exhaust

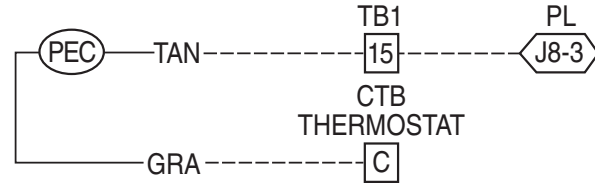

Fig. 62 — PremierLink Power Exhaust Output Connection

NOTE: The Power Exhaust and Humidi-MiZer® options can not be used with PremierLink controller at the same time as both options require connection at TB1-15 (AUX OUT).

CCN Communication Bus — The PremierLink controller connects to the bus in a daisy chain arrangement. Negative pins on each component must be connected to respective negative pins, and likewise, positive pins on each component must be connected to respective positive pins. The controller signal pins must be wired to the signal ground pins. Wiring connections for CCN must be made at the 3-pin plug.

At any baud (9600, 19200, 38400 baud), the number of controllers is limited to 239 devices maximum.

Bus length may not exceed 4000 ft, with no more than 60 total devices on any 1000-ft section. Optically isolated RS-485 repeaters are required every 1000 ft.

NOTE: Carrier device default is 9600 band.

Communications Bus Wire Specifications — The CCN Communication Bus wiring is field-supplied and field-installed. It consists of shielded 3-conductor cable with drain (ground) wire. The cable selected must be identical to the CCN Communication Bus wire used for the entire network.

See Table 28 for recommended cable.

Table 28 — Recommended Cables

MANUFACTURER	CABLE PART NO.
Alpha	2413 or 5463
American	A22503
Belden	8772
Columbia	02525

NOTE: Conductors and drain wire must be at least 20 AWG, stranded, and tinned copper. Individual conductors must be insulated with PVC, PVC/nylon, vinyl, Teflon, or polyethylene. An aluminum/polyester 100% foil shield and an outer jacket of PVC, PVC/nylon, chrome vinyl, or Teflon with a minimum operating temperature range of -20 C to 60 C is required. Do not run communication wire in the same conduit as or next to any AC voltage wiring.

The communication bus shields must be tied together at each system element. If the communication bus is entirely within one building, the resulting continuous shield must be connected to ground at only one single point. If the communication bus cable exits from one building and enters another building, the shields must be connected to the grounds at a lightning suppressor in each building (one point only).

Connecting CCN Bus

NOTE: When connecting the communication bus cable, a color code system for the entire network is recommended to simplify installation and checkout. See Table 29 for the recommended color code.

Table 29 — Color Code Recommendations

SIGNAL TYPE	CCN BUS WIRE COLOR	CCN PLUG PIN NUMBER
+	Red	1
Ground	White	2
-	Black	3

Connect the CCN (+) lead (typically RED) to the unit's TB1-12 terminal. Connect the CCN (ground) lead (typically WHT) to the unit's TB1-14 terminal. Connect the CCN (-) lead (typically BLK) to the unit's TB1-16 terminal. See Fig. 63.

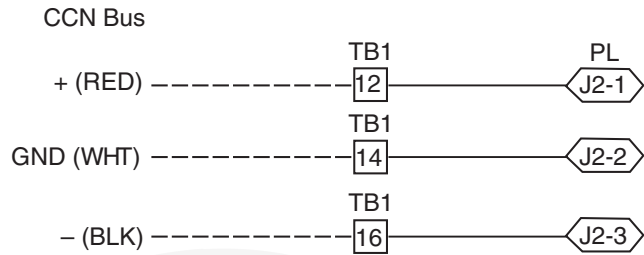

Fig. 63 — PremierLink CCN Bus Connections

RTU OPEN CONTROL SYSTEM — The RTU Open control is factory-mounted in the 48TC unit's main control box, to the left of the CTB. See Fig. 64. Factory wiring is completed through harnesses connected to the CTB. Field connections for RTU Open sensors will be made at the Phoenix connectors on the RTU Open board. The factory-installed RTU Open control includes the supply-air temperature (SAT) sensor. The outdoor air temperature (OAT) sensor is included in the FIOP/accessory EconoMiSer2 package.

The RTU Open controller is an integrated component of the Carrier rooftop unit. Its internal application programming provides optimum performance and energy efficiency. RTU Open enables the unit to run in 100% stand-alone control mode, Carrier's I-Vu® Open network, or a third party building automation system (BAS). On-board DIP switches allow you to select your protocol (and baud rate) of choice among the four most popular protocols in use today: BACnet*, Modbus†, Johnson N2 and LonWorks** (see Fig. 65 and 66).

Refer to Table 30, RTU Open Controller Inputs and Outputs for locations of all connections to the RTU Open board.

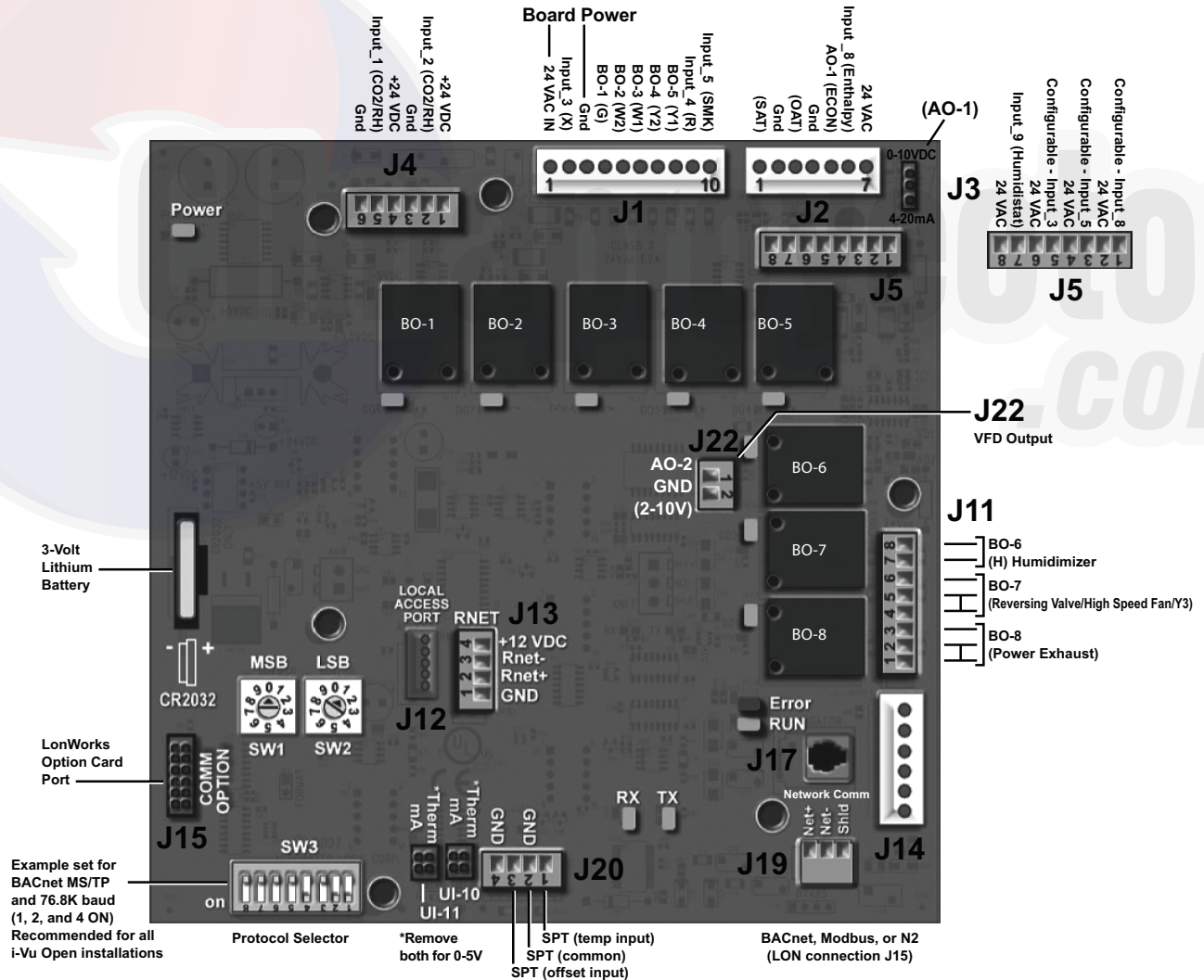

Fig. 64 — RTU Open Multi-Protocol Control Board

* BACnet is a registered trademark of ASHRAE (American Society of Heating, Refrigerating and Air-Conditioning Engineers).

† Modbus is a registered trademark of Schneider Electric.

** LonWorks is a registered trademark of Echelon Corporation.

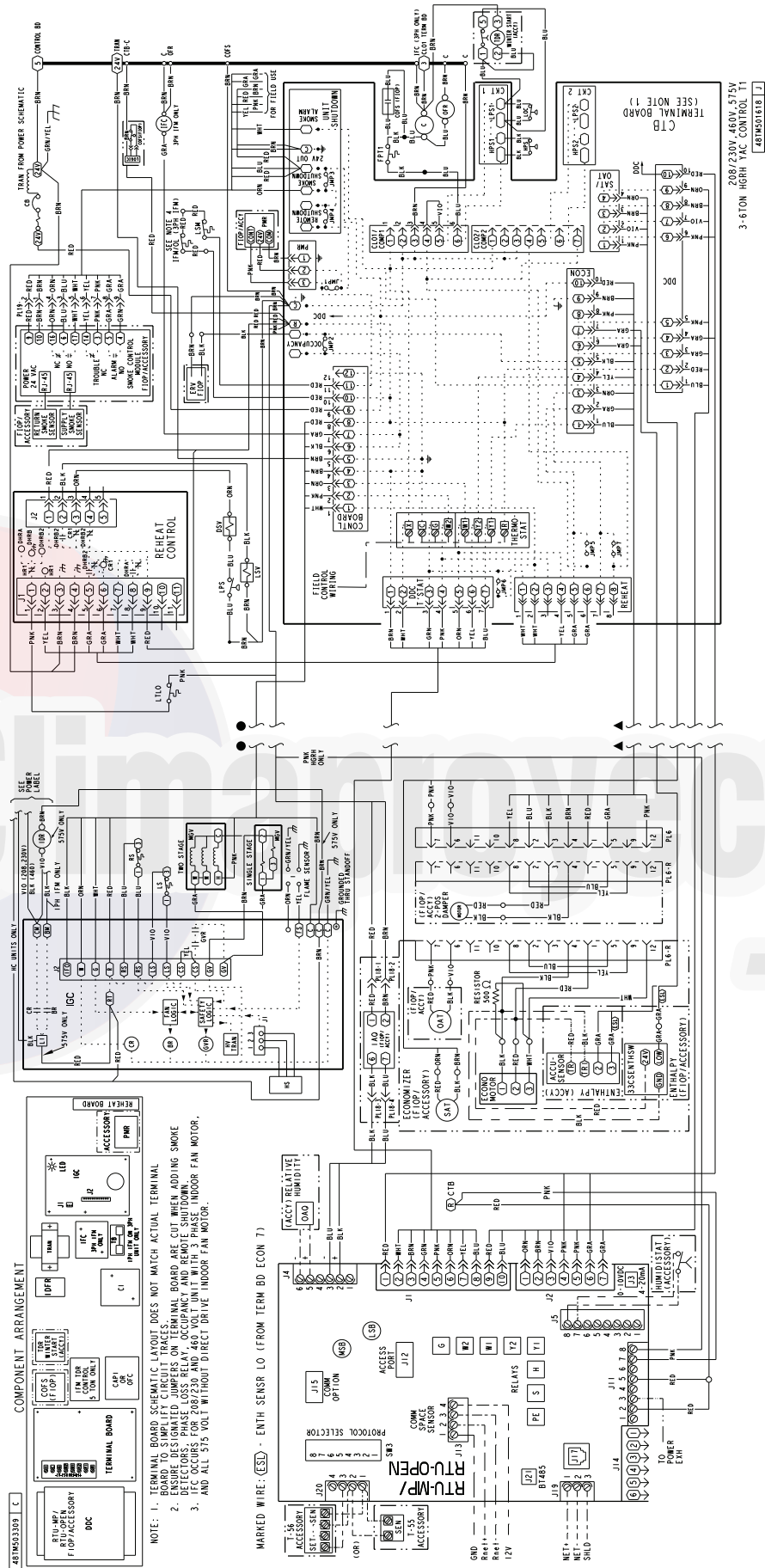

Fig. 66 — Typical RTU Open System Control Wiring Diagram with Humidi-MiZer® System

Table 30 — RTU Open Controller Inputs and Outputs

POINT NAME	BACNET OBJECT NAME	TYPE OF I/O	CONNECTION PIN NUMBER (S)	CHANNEL DESIGNATION
DEDICATED INPUTS				
Space Temp / Zone Temp	zone_temp	AI (10K Thermistor)	J20-1 & 2	Analog Input 10
Supply Air Temperature	sa_temp	AI (10K Thermistor)	J2-1 & 2	Analog Input 6
Outside Air Temperature	oa_temp	AI (10K Thermistor)	J2-3 & 4	Analog Input 7
Space Temperature Offset Pot	stpt_adj_offset	AI(100K Potentiometer)	J20-3 & 4	Analog Input 11
Safety Chain Feedback	safety_status	BI (24 VAC)	J1-9	Binary Input 4
Compressor Safety Status ¹	comp_status	BI (24 VAC)	J1-2	Binary Input 3
Fire Shutdown Status	firedown_status	BI (24 VAC)	J1-10	Binary Input 5
Enthalpy Status	enthalpy_status	BI (24 VAC)	J2-6 & 7	Binary Input 8
Humidistat Input Status	humstat_status	BI (24 VAC)	J5-7 & 8	Binary Input 9
Zone Temperature	n/a	n/a	J13-1-4	Rnet
CONFIGURABLE INPUTS⁴				
Indoor Air CO ₂	iaq	AI (4-20 mA)	J4-2 & 3 or J4-5 & 6	Analog Input 2
Outdoor Air CO ₂	oaq	AI (4-20 mA)		Analog Input 1
Space Relative Humidity	space_rh	AI (4-20 mA)		Analog Input 10
Supply Fan Status ²	sfan_status	BI (24 VAC)	J5-1 & 2 or J5-3 & 4, J5-5 & 6 or J5-7 & 8 ³	Binary Input 3, 5, 8, or 9, except where intrinsic input is used
Filter Status ²	filter_status	BI (24 VAC)		Binary Input 3, 5, 8, or 9, except where intrinsic input is used
Door Contact ²	door_contact_status	BI (24 VAC)		Binary Input 3, 5, 8, or 9, except where intrinsic input is used
Remote Occupancy Input ²	occ_contact_status	BI (24 VAC)		Binary Input 3, 5, 8, or 9, except where intrinsic input is used
IGC Input ²	igcovr_status	BI (24 VAC)		Binary Input 9. Mandatory input on gas heat units.
OUTPUTS				
Economizer Output	econ_output	AO (4-20mA)	J2-5	Analog Output 1
Supply Fan VFD	vfd_output	AO (2-10Vdc)	J22-1 & 2	Analog Output 2
Supply Fan Relay	sfan	BO Relay (24VAC, 1A)	J1-4	Binary Output 1 (G)
Cool 1 Relay State	comp_1	BO Relay (24VAC, 1A)	J1-8	Binary Output 5 (Y1)
Cool 2 Relay State	comp_2	BO Relay (24VAC, 1A)	J1-7	Binary Output 4 (Y2)
Cool 3 Relay State	comp_3	BO Relay (24VAC, 1A)	J11-5 & 6	Binary Output 7 (Y3)
Heat 1 Relay State	heat_1	BO Relay (24VAC, 1A)	J1-6	Binary Output 3 (W1)
Heat 2 Relay State	heat_2	BO Relay (24VAC, 1A)	J1-5	Binary Output 2 (W2)
Power Exhaust Relay State	pexh	BO Relay (24VAC, 1A)	J11-2 & 3 (N.O.)	Binary Output 8 (PE)
Dehumidification Relay	dehum	BO Relay (24VAC, 1A)	J11-7 & 8 (N.O.)	Binary Output 6

LEGEND

- AI** — Analog Input
- AO** — Analog Output
- BI** — Binary Input
- BO** — Binary Output

1. Safety Chain Feedback: 24Vac required at this terminal to provide “Run Enable” status. See Input/Output section for additional instructions.
2. These inputs are configurable. If installed, they take the place of the default input on the specific channel. See appropriate Input Configuration Section for wiring and setup instructions.
3. Parallel pins J5-1 = J2-6, J5-3 = J1-10, J5-5 = J1-2 are used for field installation.
4. Refer to the input configuration and accessory sections of the RTU Open Multi-Protocol Controller Controls, Start-Up, Operation and Troubleshooting manual for more detail.

Supply Air Temperature (SAT) Sensor (33ZCSENSAT) — This sensor is supplied with the 48TC unit. This sensor is a tubular probe type, approx 6-inches (152 mm) in length. It is a nominal 10-k ohm thermistor.

The SAT is factory-wired. The SAT probe is wire-tied to the supply-air opening (on the horizontal opening end) in its shipping position. Remove the sensor for installation. Re-position the sensor in the flange of the supply-air opening or in the supply air duct (as required by local codes). Drill or punch a 1/2-in. hole in the flange or duct. Use two field-supplied, self-drilling screws to secure the sensor probe in a horizontal orientation. See Fig. 47.

Outdoor Air Temperature (OAT) Sensor — This sensor is factory-mounted in the EconoMiSer2 (FIOP or accessory). It is a nominal 10k ohm thermistor attached to an eyelet mounting ring.

EconoMiSer2 (option or accessory) — The EconoMiSer 2 system is used with the RTU Open control for outdoor air management. The damper position is controlled directly by the RTU Open control; the EconoMiSer2 system has no internal logic device.

Outdoor air management functions can be enhanced with field-installation of these accessory control devices:

- Enthalpy control (outdoor air or differential sensors)
- Space CO₂ sensor
- Outdoor air CO₂ sensor

RTU OPEN CONTROL SYSTEM FIELD CONNECTIONS — Field connections for accessory sensors and input devices are made the RTU Open, at plugs J1, J2, J4, J5, J11 and J20. All field control wiring that connects to the RTU Open must be routed through the raceway built into the corner post as shown in Fig. 32.

The raceway provides the UL required clearance between high and low-voltage wiring. Pass the control wires through the hole provided in the corner post, then feed the wires thorough the raceway to the RTU Open. Connect to the wires to the removable Phoenix connectors and then reconnect the connectors to the board.

Space Temperature (SPT) Sensors — There are two types of SPT sensors available from Carrier, resistive input non-communicating (T55, T56, and T59) and Rnet communicating (SPS, SPPL, SPP, and SPPF) sensors. Each type has a variety of options consisting of: timed override button, set-point adjustment, a LCD screen, and communication tie in. Space temperature can be also be written to from a building network or zoning system. However, it is still recommended that return air duct sensor be installed to allow stand-alone operation for back-up. Refer to the configuration section for details on controller configurations associated with space sensors.

- 33ZCT55SPT, space temperature sensor with override button (T-55)
- 33ZCT56SPT, space temperature sensor with override button and set-point adjustment (T-56)
- 33ZCT59SPT, space temperature sensor with LCD (liquid crystal display) screen, override button, and setpoint adjustment (T-59)

Use 20 gauge wire to connect the sensor to the controller. The wire is suitable for distances of up to 500 ft. Use a three-conductor shielded cable for the sensor and setpoint adjustment connections. If the setpoint adjustment (slidebar) is not required, then an unshielded, 18 or 20 gauge, two-conductor, twisted pair cable may be used.

Connect T- 55 — See Fig. 43 for typical T-55 internal connections. Connect the T-55 SEN terminals to RTU Open J20-1 and J20-2. See Fig. 67.

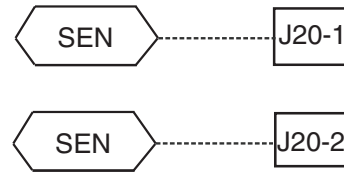

Fig. 67 — RTU Open T-55 Sensor Connections

Connect T- 56 — See Fig. 45 for T-56 internal connections. Install a jumper between SEN and SET terminals as illustrated. Connect T-56 terminals to RTU Open J20-1, J20-2 and J20-3 per Fig. 68.

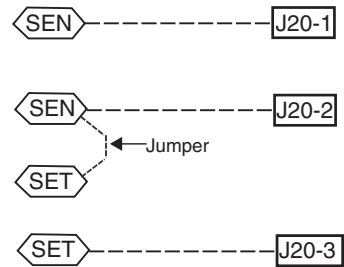
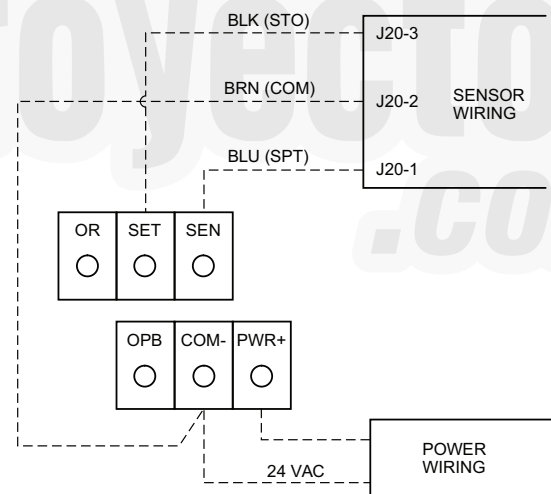

Fig. 68 — RTU Open T-56 Sensor Connections

Connect T-59 — The T-59 space sensor requires a separate, isolated power supply of 24 VAC. See Fig. 69 for internal connections at the T-59. Connect the SEN terminal (BLU) to RTU Open J20-1. Connect the COM terminal (BRN) to J20-2. Connect the SET terminal (STO or BLK) to J20-3.



NOTE: Must use a separate isolated transformer.

Fig. 69 — Space Temperature Sensor Typical Wiring (33ZCT59SPT)

Indoor Air Quality (CO₂) Sensor — The indoor air quality sensor accessory monitors space carbon dioxide (CO₂) levels. This information is used to monitor IAQ levels. Several types of sensors are available, for wall mounting in the space or in return duct, with and without LCD display, and in combination with space temperature sensors. Sensors use infrared technology to measure the levels of CO₂ present in the space air.

The CO₂ sensors are all factory set for a range of 0 to 2000 ppm and a linear mA output of 4 to 20. Refer to the instructions supplied with the CO₂ sensor for electrical requirements and terminal locations. See Fig. 53 for typical CO₂ sensor wiring schematic.

To accurately monitor the quality of the air in the conditioned air space, locate the sensor near a return-air grille (if present) so it senses the concentration of CO₂ leaving the space. The sensor should be mounted in a location to avoid direct breath contact.

Do not mount the IAQ sensor in drafty areas such as near supply ducts, open windows, fans, or over heat sources. Allow at least 3 ft (0.9 m) between the sensor and any corner. Avoid mounting the sensor where it is influenced by the supply air; the sensor gives inaccurate readings if the supply air is blown directly onto the sensor or if the supply air does not have a chance to mix with the room air before it is drawn into the return airstream.

Wiring the Indoor Air Quality Sensor — For each sensor, use two 2-conductor 18 AWG (American Wire Gauge) twisted-pair cables (unshielded) to connect the separate isolated 24 vac power source to the sensor and to connect the sensor to the control board terminals.

To connect the sensor to the control, identify the positive (4 to 20 mA) and ground (SIG COM) terminals on the sensor. See Fig. 53. Connect the 4-20 mA terminal to RTU Open J4-2 and connect the SIG COM terminal to RTU Open J4-3. See Fig. 70.

IAQ Sensor

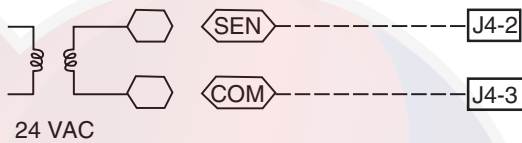

Fig. 70 — RTU Open/Indoor CO₂ Sensor (33ZCSENCO2) Connections

Outdoor Air Quality Sensor (P/N 33ZCSENCO2 plus weatherproof enclosure) — The sensor is designed to monitor carbon dioxide (CO₂) levels in the outside ventilation air and interface with the ventilation damper in an HVAC system. The OAQ sensor is packaged with an outdoor cover. See Fig. 55. The outdoor air CO₂ sensor must be located in the economizer outside air hood.

Wiring the Outdoor Air CO₂ Sensor — A dedicated power supply is required for this sensor. A two-wire cable is required to wire the dedicated power supply for the sensor. The two wires should be connected to the power supply and terminals 1 and 2.

To connect the sensor to the control, identify the positive (4 to 20 mA) and ground (SIG COM) terminals on the OAQ sensor. See Fig. 53. Connect the 4 to 20 mA terminal to RTU Open J4-5. Connect the SIG COM terminal to RTU Open J4-6. See Fig. 71.

OAQ Sensor

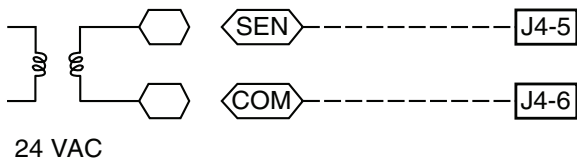

Fig. 71 — RTU Open / Outdoor CO₂ Sensor (33ZCSENCO2) Connections

Space Relative Humidity Sensor or Humidistat

NOTE: The accessory space relative humidity sensor and humidistat are not available for single phase (-3 voltage code) models.

Humidi-MiZer® Control Wiring — In units equipped with the Humidi-MiZer option there are two pink (PNK) wires loose in the control box used to control the dehumidification function of the unit. These pink wires are meant to be tied to a space humidistat or thermidstat on an electromechanical unit. On RTU Open equipped units these pink wires must be connected to J11-7 and 8 to allow the Open board to operate the dehumidification function for the unit. Disconnect the J11 Phoenix style connector from the board and use the plug screws to secure the pink wires in pins 7 and 8, reconnect the plug to the board at J11.

NOTE: The Humidi-MiZer system is a factory-installed option which is available for 07 models only.

Relative Humidity Sensors (Space or Duct Mounted) — The accessory space humidity sensor (33ZCSENSRH-01) or duct humidity sensor (33ZCSENDRH-01) is used to measure the relative humidity of air within the space or return air duct. The RH reading is used to control the Humidi-MiZer option of the rooftop unit. For wiring distances up to 500 ft (152 m), use a 3-conductor, 18 or 20 AWG shielded cable. The shield must be removed from the sensor end of the cable and grounded at the unit end. The current loop power for sensor is provided by the RTU Open controller as 24vdc. Refer to the instructions supplied with the RH sensor for the electrical requirements and terminal locations. RTU Open configurations must be changed after adding an RH sensor. See Fig. 72 and 73 for typical RH sensor wiring.

- J4-1 or J4-4 = 24vdc loop power
- J4-2 or J4-5 = 4-20mA signal input

NOTE: The factory default for dehumidification control is normally open humidistat.

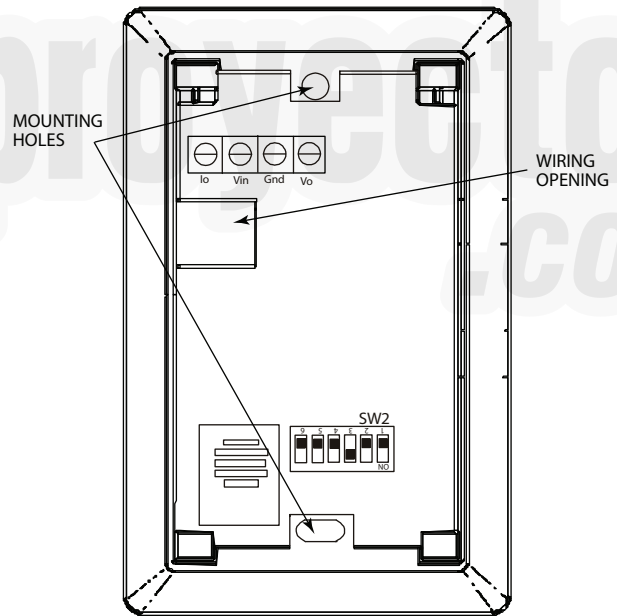

Vin - J4-1 or J4-4 24Vdc
Io - J4-2 or J4-5 -20mA output

Fig. 72 — Space Relative Humidity Sensor Typical Wiring

Humidistat — The accessory humidistat provides the RTU Open insight to the relative humidity in the space. The humidistat reads the RH level in the space and compares it to its set-point to operate a dry contact. The humidistat is a dedicated input on the configurable input 9 and tells the RTU Open when the RH level is HIGH or LOW. The normal condition for hu-

midity is LOW. A normally open humidistat is the factory default control for the Humidi-MiZer® option.

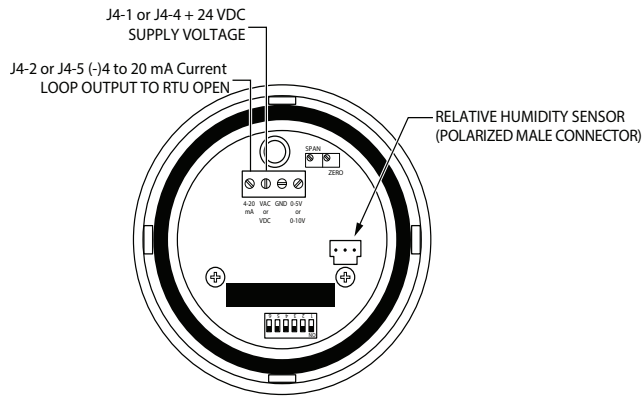

Fig. 73 — Duct Relative Humidity Sensor Typical Wiring

To wire in the field:

- J5-8 = 24 VAC source for dry contact
- J5-7 = Signal input

Smoke Detector/Fire Shutdown (FSD) — This control is installed on 48TC units equipped with factory-installed Smoke Detector(s). The smoke detector controller implements the unit shutdown through its NC contact set connected to the unit’s CTB input. The FSD function is initiated via the smoke detector’s Alarm NO contact set. The RTU Open controller communicates the smoke detector’s tripped status to the BAS building control. See Fig. 65 and 66, the RTU Open System Control wiring schematics.

The Fire Shutdown Switch configuration, MENU>Config>Inputs>input 5, identifies the normally open status of this input when there is no fire alarm.

Connecting Discrete Inputs

Filter Status — The filter status accessory is a field-installed accessory. This accessory detects plugged filters. When installing this accessory, the unit must be configured for filter status by setting MENU>Config>Inputs>input 3, 5, 8, or 9 to Filter Status and normally open (N/O) or normally closed (N/C). Input 8 or 9 is recommended for easy of installation. Refer to Fig. 64-66 for wire terminations at J5.

Fan Status — The fan status accessory is a field-installed accessory. This accessory detects when the indoor fan is blowing air. When installing this accessory, the unit must be configured

for fan status by setting MENU>Config>Inputs>input 3, 5, 8, or 9 to Fan Status and normally open (N/O) or normally closed (N/C). Input 8 or 9 is recommended for easy of installation. Refer to Fig. 64 and Fig. 65 or 66 for wire terminations at J5.

Remote Occupancy — The remote occupancy accessory is a field-installed accessory. This accessory overrides the unoccupied mode and puts the unit in occupied mode. When installing this accessory, the unit must be configured for remote occupancy by setting MENU>Config>Inputs>input 3, 5, 8, or 9 to Remote Occupancy and normally open (N/O) or normally closed (N/C).

Also set MENU>Schedules>occupancy source to DI on/off. Input 8 or 9 is recommended for easy of installation. Refer to Fig. 64 and Table 30 for wire terminations at J5.

Power Exhaust (output) — The relay used by the RTU Open board to control power exhaust is a dry contact which means it does not have 24vac. This 24vac must be connected to the relay to allow it to operate the power exhaust relay in the PE accessory. A 24vac source must be provided to J11-2 on the RTU Open control board. This can be provided by the unit’s transformer from various sources. The “R” terminal on the unit’s low voltage terminal board (LVTB) is a logical source. Refer to Fig. 64-66 for wire terminations at J11.

RTU OPEN COMMUNICATION WIRING-PROTOCOLS

General — Protocols are the communication languages spoken by control devices. The main purpose of a protocol is to communicate information in the most efficient method possible. Different protocols exist to provide different kinds of information for different applications. In the BAS application, many different protocols are used, depending on manufacturer. Protocols do not change the function of a controller; just make the front end user different.

The RTU Open can be set to communicate on four different protocols: BACnet, Modbus, N2, and LonWorks. Switch 3 (SW3) on the board is used to set protocol and baud rate. Switches 1 and 2 (SW1 and SW2) are used to set the board’s network address. See Fig. 74 and 75 for protocol switch settings and address switches. The third party connection to the RTU Open is through plug J19. See Fig. 76 for wiring.

NOTE: Power must be cycled after changing the SW1-3 switch settings.

Refer to the RTU Open v3 Integration Guide for more detailed information on protocols 3rd party wiring and networking.

SW3 PROTOCOL SELECTION

PROTOCOL	DS8	DS7	DS6	DS5	DS4	DS3	DS2	DS1
BACnet MS/TP (Master)	Unused	OFF	OFF	OFF	ON	OFF	Select Baud	Select Baud
Modbus (Slave)	Unused	OFF	OFF	ON	ON	OFF	Select Baud	Select Baud
N2 Slave	Unused	OFF	OFF	OFF	ON	ON	OFF	OFF
LonWorks	Unused	ON	ON	OFF	ON	OFF	OFF	ON

LEGEND

DS — DIP Switch

NOTE: BACnet MS/TP SW3 example shown.

Baud Rate Selection

BAUD RATE	DS2	DS1
9,600	OFF	OFF
19,200	ON	OFF
38,400	OFF	ON
76,800	ON	ON

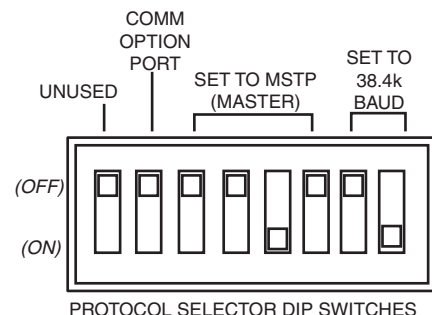

Fig. 74 — RTU Open SW3 Dip Switch Settings

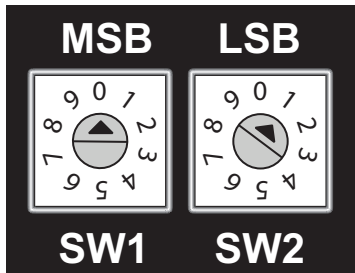

Fig. 75 — RTU Open Address Switches

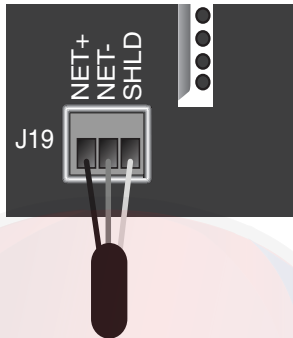

Fig. 76 — Network Wiring

LOCAL ACCESS

Wall Mounted Equipment Touch — The Equipment Touch is a wall mounted interface used to connect to the RTU Open to access the control information, read sensor values, and maintenance. This is an accessory interface that does not come with the RTU Open controller. Wire the Equipment Touch interface to the RTU Open's J13 local access port. There are 2 password protected levels in the display (User and Admin). See the Equipment Touch Installation and Setup Guide for more information. See Appendix A of the Equipment Touch Installation and Setup Guide for navigation and screen content.

Field Assistant — Field Assistant is a computer program included with the purchase of the Tech Tool Kit (USB-TKIT). This is a field Tech Tool to set-up, service, or download application software to the RTU Open controller and includes a USB link cable. The link cable connects a USB port to the J12 local access port. The Field Assistant's menu structure is similar and functions the same as i-Vu® Open controller. See Fig. 77.

RTU Open Troubleshooting — Troubleshooting is accomplished by viewing the communication LEDs. The LEDs indicate if the controller is speaking to the devices on the network. The LEDs should reflect communication traffic based on the baud rate set. The higher the baud rate the more solid the LEDs will appear. See Table 31 and Fig 77.

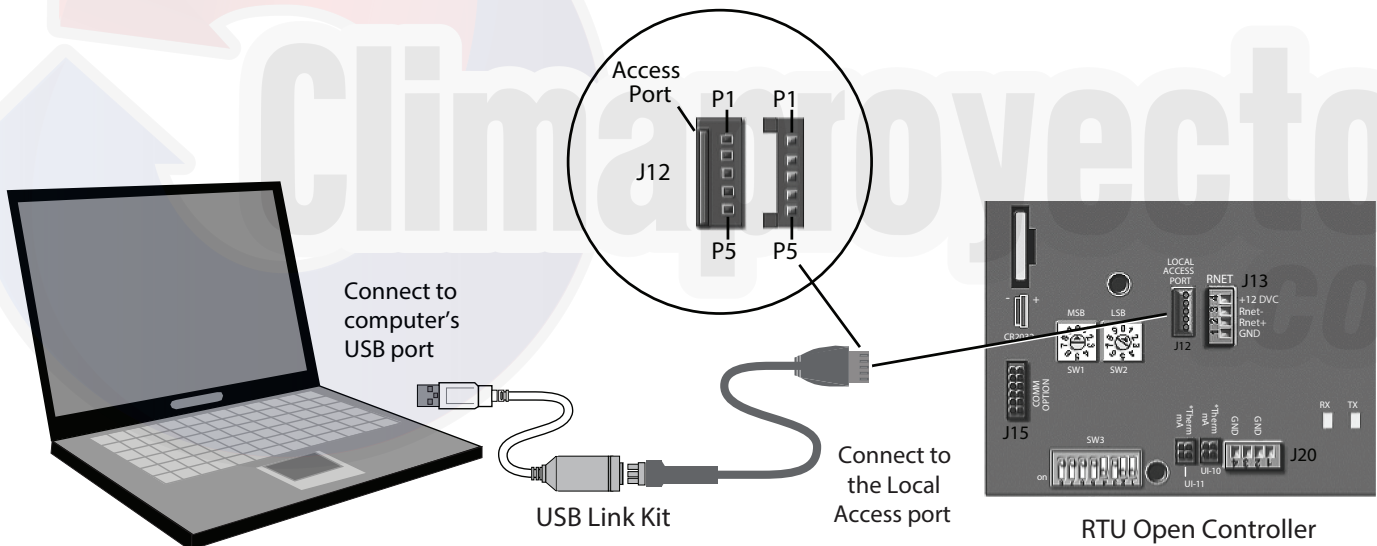

Fig. 77 — PC Running Field Assistant

Table 31 — LEDs

(The LEDs on the RTU Open show the status of certain functions)

IF THIS LED IS ON...	THE STATUS IS...	
Power	RTU Open has power	
Rx	RTU Open is receiving data from the network segment	
Tx	RTU Open is transmitting data over the network segment	
DO#	The digital output is active	
The Run and Error LEDs indicate control module and network status		
2 Flashes Per Second	Off	Normal
2 Flashes Per Second	2 flashes, alternating with Run LED	Five minute auto-restart delay after system error
2 Flashes Per Second	3 flashes, then off	Control module has just been formatted
2 Flashes Per Second	4 flashes, then pause	Two or more devices on this network have the same ARC156
2 Flashes Per Second	On	Network address
5 Flashes Per Second	On	Exec start-up aborted, Boot is running
5 Flashes Per Second	Off	Firmware transfer in progress, Boot is running
7 Flashes Per Second	7 flashes per second, alternating with Run LED	Ten second recovery period after brownout
14 Flashes Per Second	14 flashes per second, alternating with Run LED	Brownout
On	On	Failure. Try the following solutions: <ul style="list-style-type: none"> • Turn RTU Open off, then on • Format RTU Open • Download memory to RTU Open • Replace RTU Open

NOTE: Refer to the RTU Open Multi-Protocol Controller Controls, Start-Up, Operation and Troubleshooting manual for complete configuration of RTU Open, operating sequences and troubleshooting information. Refer to the RTU Open v3 Integration Guide for details on configuration and troubleshooting of connected networks. Have a copy of these manuals available at unit start-up.

OUTDOOR AIR ENTHALPY CONTROL (PN: 33CSENTHSW) — The enthalpy control is available as a field-installed accessory to be used with the EconoMiSer2 damper system. The outdoor air enthalpy sensor is part of the enthalpy control. (The separate field-installed accessory return air enthalpy sensor (33CSENTSEN) is required for differential enthalpy control (see Fig. 78).

Locate the enthalpy control in the economizer next to the Actuator Motor. Locate two GRA leads in the factory harness and connect the gray lead labeled “ESL” to the terminal labeled “LOW”. See Fig. 78. Connect the enthalpy control power input terminals to economizer actuator power leads RED (connect to 24V) and BLK (connect to GND).

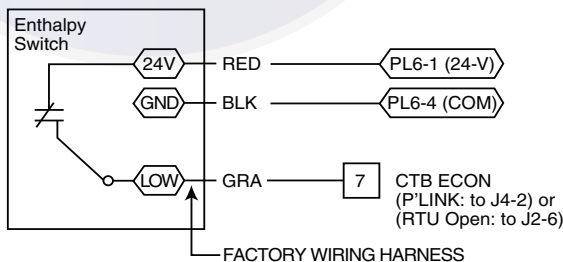

Fig. 78 — Enthalpy Switch (33CSENTHSW) Connections

The outdoor enthalpy changeover setpoint is set at the enthalpy controller.

Differential Enthalpy Control — Control is provided by sensing and comparing the outside air and return air enthalpy con-

ditions. Install the outdoor air enthalpy control as described above. Add and install a return air enthalpy sensor.

Return Air Enthalpy Sensor (33CSENTSEN) — The sensor is mounted in the return-air section of the economizer. The return air sensor is wired to the enthalpy controller (33CSENTHSW). See Fig. 79.

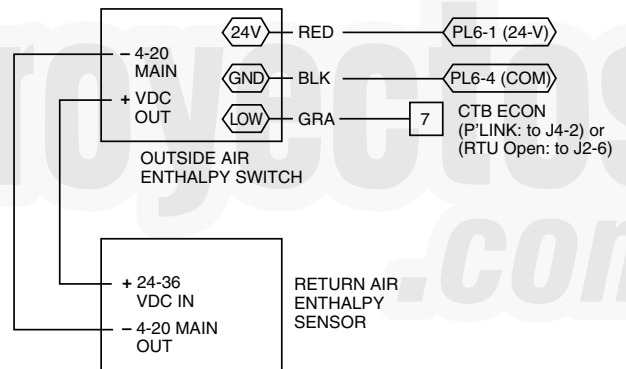

Fig. 79 — Outside and Return Air Enthalpy Sensor Wiring

SMOKE DETECTORS — Smoke detectors are available as factory-installed options on 48TC models. Smoke detectors may be specified for Supply Air only or for Return Air without or with economizer or in combination of Supply Air and Return Air. All components necessary for operation are factory-provided and mounted. The unit is factory-configured for immediate smoke detector shutdown operation; additional wiring or modifications to unit terminal board may be necessary to complete the unit and smoke detector configuration to meet project requirements.

Units equipped with factory-optional Return Air smoke detectors require a relocation of the sensor module at unit installation. See Fig. 80 for the as shipped location.

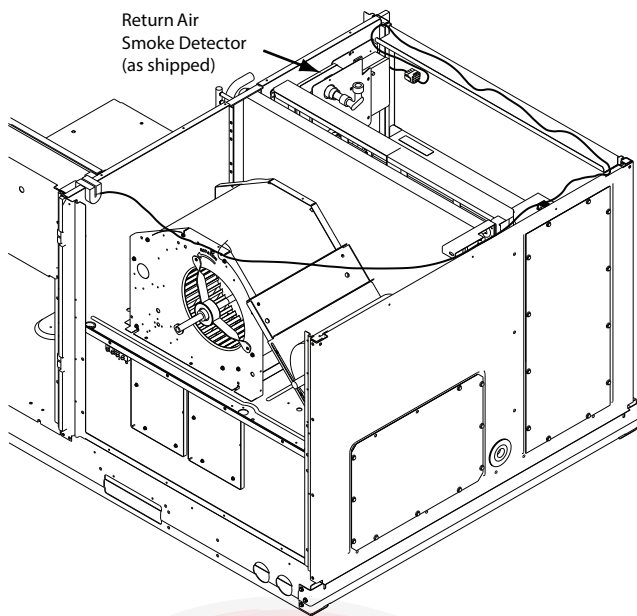

Fig. 80 — Return Air Smoke Detector; Shipping Position

Completing Installation of Return Air Smoke Sensor

1. Unscrew the two screws holding the Return Air Smoke Detector assembly. See Fig. 81, Step 1. Save the screws.
2. Turn the assembly 90 and then rotate end to end. Make sure that the elbow fitting is pointing down. See Fig. 81, Step 2.
3. Screw the sensor and detector plate into its operating position using screws from Step 1. See Fig. 81, Step 3.
4. Connect the flexible tube on the sampling inlet to the sampling tube on the basepan.

Additional Application Data — Refer to the application data sheet titled “Factory Installed Smoke Detector for Small and Medium Rooftop Units, 2 to 25 Tons” for discussions on additional control features of these smoke detectors including multiple unit coordination.

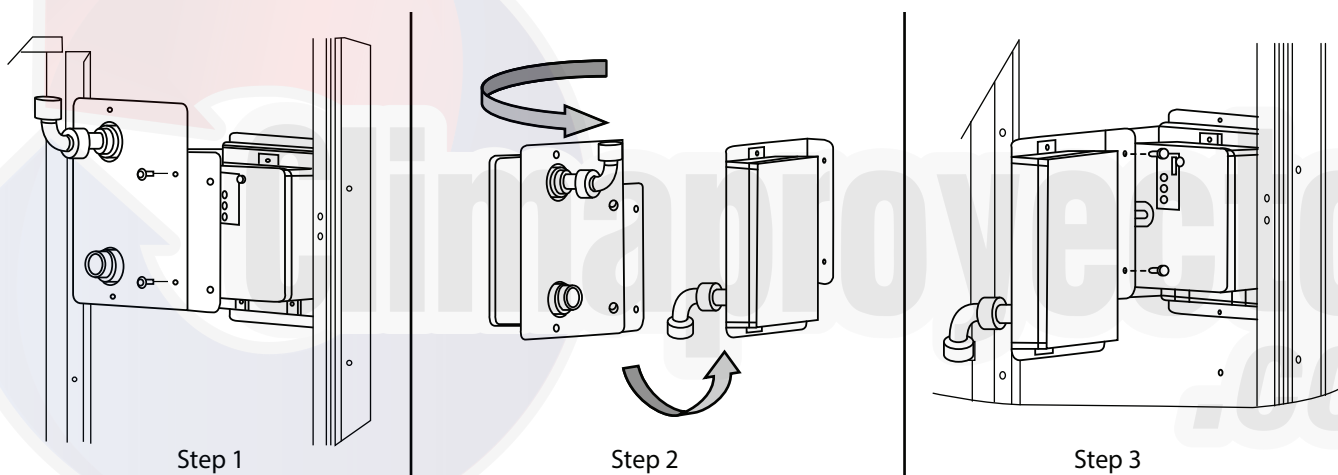

Fig. 81 — Completing Installation of Return Air Smoke Sensor

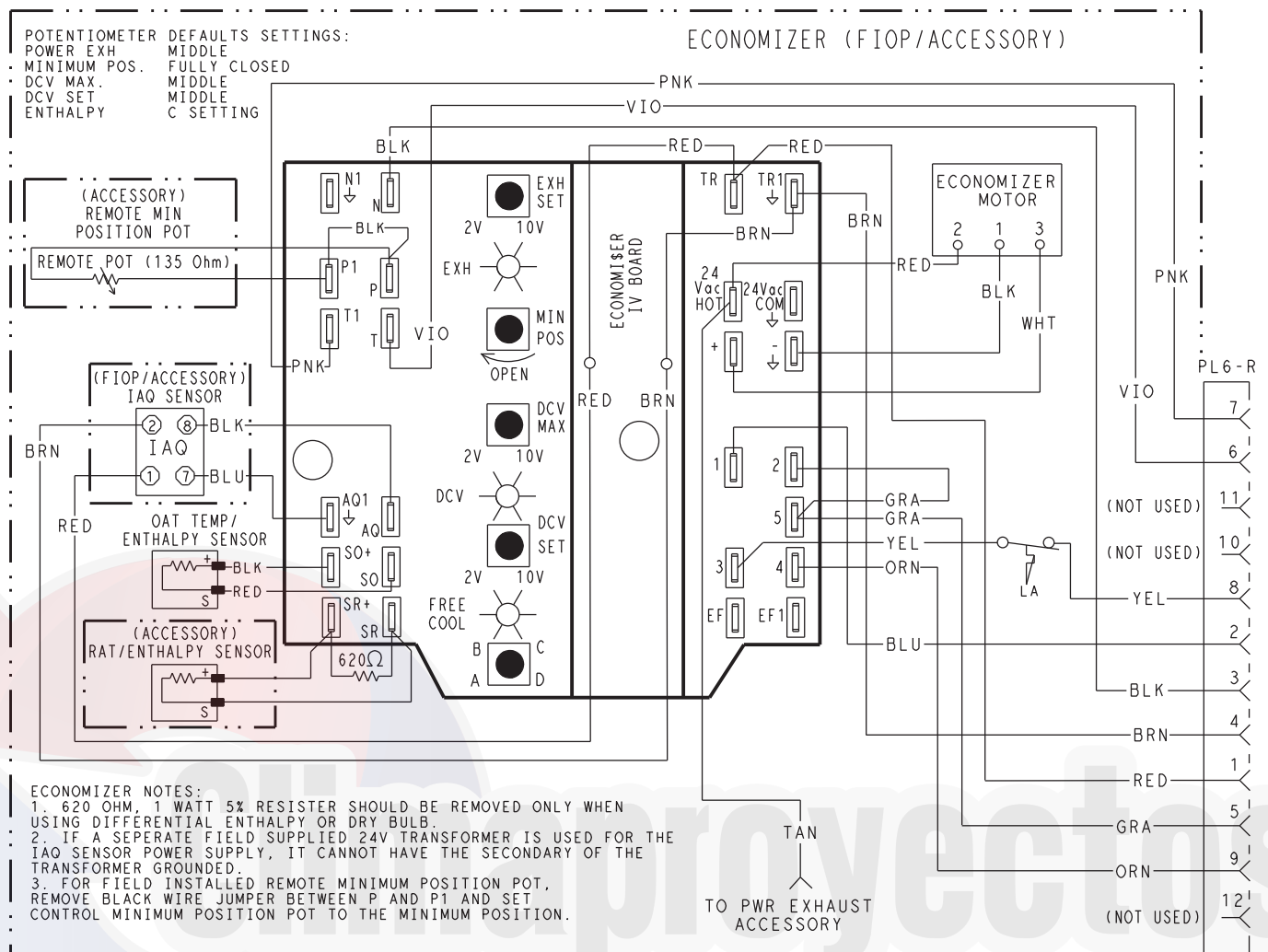

Fig. 82 — EconoMiSer IV Wiring

Step 13 — Adjust Factory-Installed Options

SMOKE DETECTORS — Smoke detector(s) will be connected at the Controls Connections Board, at terminals marked “Smoke Shutdown”. Cut jumper JMP 3 when ready to energize unit.

ECONOMISER IV OCCUPANCY SWITCH — Refer to Fig. 82 for general EconoMiSer IV wiring. External occupancy control is managed through a connection on the Controls Connections Board.

If external occupancy control is desired, connect a time clock or remotely controlled switch (closed for Occupied, open for Unoccupied sequence) at terminals marked OCCUPANCY. Cut jumper JMP 2 to complete the installation.

Step 14 — Install Accessories

Available accessories include:

- Curb
- Thru-base connection kit (must be installed before unit is set on curb)
- LP conversion kit
- Flue discharge deflector
- Manual outside air damper
- Two-Position motorized outside air damper
- EconoMiSer IV (with control)
- EconoMiSer2 (without control/for external signal)

- Power Exhaust
- Differential dry-bulb sensor (EconoMiSer IV)
- Outdoor enthalpy sensor
- Differential enthalpy sensor
- CO₂ sensor
- DDC interface (PremierLink)
- Louvered hail guard
- Motormaster® head pressure controls
- Phase monitor control

Refer to separate installation instructions for information on installing these accessories.

Step 15 — Check Belt Tension — Measure the belt span length as shown in Fig. 83. Calculate the required deflection by multiplying the belt span length by $\frac{1}{64}$. For example, if the belt span length is 32 inches: $32 \times \frac{1}{64} = \frac{1}{2}$ inch deflection.

BELT FORCE — DEFLECTION METHOD — Check the belt tension with a spring-force belt force deflection gauge (available from drive belt manufacturer).

1. Place a straightedge along the belt between the two pulleys. Measure the distance between the motor shaft and the blower shaft.
2. Set the tension gauge to the desired tension (see Table 1 in Fig. 83). Place the large O-ring at that point.

3. Press the tension checker downward on the belt until the large O-ring is at the bottom of the straightedge.
4. Adjust the belt tension as needed.

Adjust belt tension by loosening the motor mounting plate front bolts and rear bolt (see Fig. 84) and slide the plate towards the fan (to reduce tension) or away from the fan (to increase tension). Ensure the blower shaft and motor shaft are parallel to each other (pulleys aligned). Tighten all bolts securely when finished.

BELT TENSION METHOD — Requires belt tension gauge that measures tension in belt in units of lbs force.

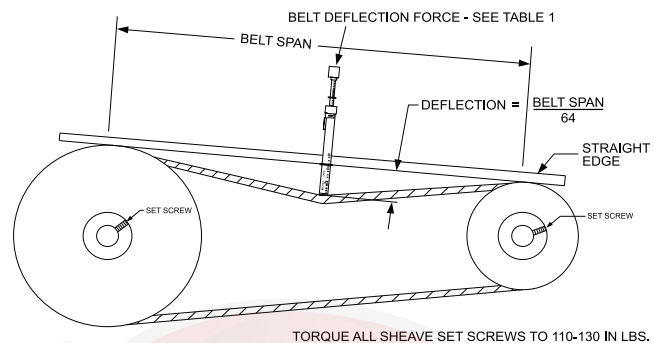

BELT CROSS SECTION	SMALLEST SHEAVE DIAMETER	BELT DEFLECTION FORCE (LBS)			
		UNNOTCHED BELTS		NOTCHED BELTS	
		USED	NEW	USED	NEW
A, AX	3.0-3.6	3.7	5.5	4.1	6.1
	3.8-4.8	4.5	6.8	5.0	7.4
	5.0-7.0	5.4	8.0	5.7	8.4
B, BX	3.4-4.2	—	—	4.9	7.2
	4.4-5.6	5.3	7.9	7.1	10.5
	5.8-8.6	6.3	9.4	8.5	12.6

Table 1

BELT CONDITION	TENSION FORCE IN BELT (LBS)
New	100
Used	80

Table 2

Fig. 83 — V-Belt Force Label

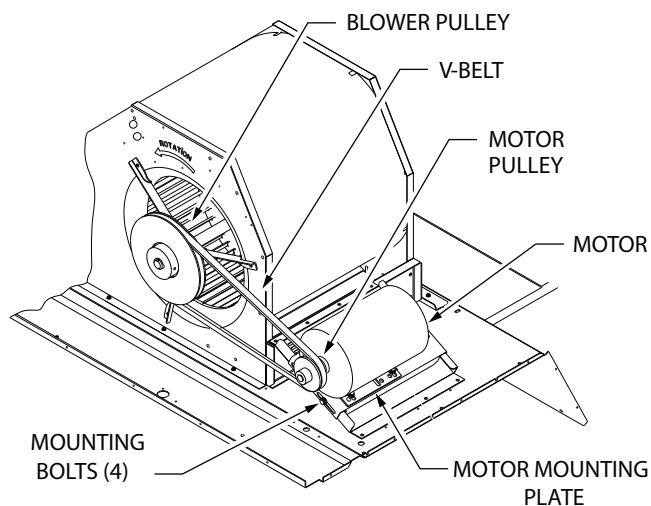

Fig. 84 — Belt Drive Motor Mounting

Pre-Start and Start-Up — This completes the mechanical installation of the unit. Refer to the unit's Service Manual for detailed Pre-Start and Start-Up instructions. Download the latest versions from HVAC Partners (www.hvacpartners.com).

START-UP CHECKLIST — 48TC PACKAGED ROOFTOP UNITS WITH GAS HEAT AND ELECTRIC COOLING

NOTE: To avoid injury to personnel and damage to equipment or property when completing the procedures listed in this start-up checklist, use good judgment, follow safe practices, and adhere to the safety considerations/information as outlined in preceding sections of this Installation Instruction document.

I. PRELIMINARY INFORMATION

MODEL NO. JOB NAME _____
SERIAL NO. ADDRESS _____
START-UP DATE _____
TECHNICIAN NAME _____
ADDITIONAL ACCESSORIES _____

II. PRE-START-UP

Verify that all packaging materials have been removed from unit (Y/N) _____
Verify installation of outdoor air hood (Y/N) _____
Verify installation of flue exhaust and inlet hood (Y/N) _____
Verify that condensate connection is installed per instructions verify that all electrical (Y/N) _____
Connections and terminals are tight (Y/N) _____
Verify gas pressure to unit gas valve is within specified range (Y/N) _____
Check gas piping for leaks (Y/N) _____
Check that indoor-air filters are clean and in place (Y/N) _____
Check that outdoor air inlet screens are in place (Y/N) _____
Verify that unit is level (Y/N) _____
Check fan wheels and propeller for location in housing/orifice and verify setscrew is tight (Y/N) _____
Verify that fan sheaves are aligned and belts are properly tensioned (Y/N) _____
Verify that scroll compressors are rotating in the correct direction (Y/N) _____
Verify installation of thermostat (Y/N) _____
Verify that crankcase heaters have been energized for at least 24 hours (Y/N) _____

II. START-UP

ELECTRICAL

Supply Voltage	L1-L2 _____	L2-L3 _____	L3-L1 _____
Compressor Amps 1	L1 _____	L2 _____	L3 _____
Compressor Amps 2	L1 _____	L2 _____	L3 _____
Supply Fan Amps	L1 _____	L2 _____	L3 _____

TEMPERATURES

Outdoor-air Temperature _____ °F DB (Dry Bulb)
Return-air Temperature _____ °F DB _____ °F Wb (Wet Bulb)
Cooling Supply Air Temperature _____ °F
Gas Heat Supply Air _____ °F

PRESSURES

GAS INLET PRESSURE IN. WG
GAS MANIFOLD PRESSURE STAGE 1 _____ in.wg
STAGE 2 _____ in.wg
REFRIGERANT SUCTION CIRCUIT A _____ PSIG
CIRCUIT B _____ PSIG
REFRIGERANT DISCHARGE CIRCUIT A _____ PSIG
CIRCUIT B _____ PSIG
VERIFY REFRIGERANT CHARGE USING CHARGING CHARTS (Y/N) _____

GENERAL

Economizer minimum vent and changeover settings to job requirements (if equipped) (Y/N) _____
Verify smoke detector unit shutdown by utilizing magnet test (Y/N) _____

III. HUMIDI-MIZER® START-UP (48TC*B07 ONLY)

STEPS

- 1. Check CTB for jumper 5, 6, 7 (Jumper 5, 6, 7 must be cut and open) (Y/N) _____
- 2. Open humidistat contacts (Y/N) _____
- 3. Start unit In cooling (Close Y1) (Y/N) _____

OBSERVE AND RECORD

- A. Suction pressure _____ PSIG
 - B. Discharge pressure _____ PSIG
 - C. Entering air temperature _____ ° F
 - D. Liquid line temperature at outlet or reheat coil _____ ° F
 - E. Confirm correct rotation for compressor (Y/N) _____
 - F. Check for correct ramp-up of outdoor fan motor as condenser coil warms (Y/N) _____
4. Check unit charge per charging chart (Y/N) _____
(Jumper 32L Motormaster® temperature sensor during this check. Remove jumper when complete.)
5. Switch unit to high-latent mode (sub-cooler) by closing humidistat with Y1 closed (Y/N) _____

OBSERVE

- A. Reduction in suction pressure (5 to 7 psi expected) (Y/N) _____
 - B. Discharge pressure unchanged (Limited by Motormaster) (Y/N) _____
 - C. Liquid temperature drops to 50 to 55 F range (Y/N) _____
 - D. LSV solenoid energized (valve closes) (Y/N) _____
6. Switch unit to dehumid (reheat) by opening Y1 (Y/N) _____

OBSERVE

- A. suction pressure increases to normal cooling level
 - B. discharge pressure decreases (35 to 50 psi)
 - C. liquid temperature returns to normal cooling level
 - D. LSV solenoid energized (valve closes)
 - E. DSV solenoid energized, valve opens
7. With unit in dehumid mode close W1 compressor and outdoor fan stop; LSV and DSV solenoids de-energized (Y/N) _____
8. Open W1 restore unit to dehumid mode (Y/N) _____
9. Open humidistat input compressor and outdoor fan stop; LSV and DSV solenoids de-energized (Y/N) _____
10. Restore set-points for thermostat and humidistat (Y/N) _____

CUT ALONG DOTTED LINE