



Installation Instructions

CONTENTS

| | Page |
|--|------|
| SAFETY CONSIDERATIONS | 1 |
| GENERAL | 2 |
| Rated Indoor Airflow (cfm) | 2 |
| INSTALLATION | 19 |
| Jobsite Survey | 19 |
| Step 1 — Plan for Unit Location | 19 |
| • ROOF MOUNT | |
| Step 2 — Plan for Sequence of Unit Installation .. | 19 |
| • CURB-MOUNTED INSTALLATION | |
| • PAD-MOUNTED INSTALLATION | |
| • FRAME-MOUNTED INSTALLATION | |
| Step 3 — Inspect Unit | 19 |
| Step 4 — Provide Unit Support | 19 |
| • ROOF CURB MOUNT | |
| • SLAB MOUNT (HORIZONTAL UNITS ONLY) | |
| • ALTERNATE UNIT SUPPORT (IN LIEU OF CURB OR SLAB MOUNT) | |
| Step 5 — Field Fabricate Ductwork | 24 |
| Step 6 — Rig and Place Unit | 24 |
| • POSITIONING ON CURB | |
| Step 7 — Horizontal Duct Connection | 25 |
| Step 8 — Install Outside Air Hood — Factory Option | 25 |
| Step 9 — Assemble Barometric Hood | 27 |
| • BAROMETRIC HOOD (VERTICAL CONFIGURATION) | |
| • BAROMETRIC HOOD (HORIZONTAL CONFIGURATION) | |
| Step 10 — Install External Condensate Trap and Line | 28 |
| Step 11 — Make Electrical Connections | 29 |
| • FIELD POWER SUPPLY | |
| • UNITS WITHOUT FACTORY-INSTALLED NON-FUSED DISCONNECT OR HACR | |
| • UNITS WITH FACTORY-INSTALLED NON-FUSED DISCONNECT OR HACR | |
| • ALL UNITS | |
| • CONVENIENCE OUTLETS | |
| • HACR | |
| • FACTORY OPTION THRU-BASE CONNECTIONS | |
| • UNITS WITHOUT THRU-BASE CONNECTIONS | |
| • FIELD CONTROL WIRING | |
| • THERMOSTAT | |
| • UNIT WITHOUT THRU-BASE CONNECTION KIT | |
| • HEAT ANTICIPATOR SETTINGS | |
| • TRANSFORMER CONNECTION FOR 208-V POWER SUPPLY | |
| Electric Heaters | 34 |
| • LOW-VOLTAGE CONTROL CONNECTIONS | |
| Humidi-MiZer® System Control Connections | 35 |
| • HUMIDI-MIZER — SPACE RH CONTROLLER | |

EconoMiSer® X (Factory-Installed Option) 37

- PRODUCT DESCRIPTION
- SYSTEM COMPONENTS
- SPECIFICATIONS
- INPUTS
- OUTPUTS
- ENVIRONMENTAL
- ECONOMIZER MODULE WIRING DETAILS
- S-BUS SENSOR WIRING
- CO2 SENSOR WIRING
- INTERFACE OVERVIEW
- USER INTERFACE
- KEYPAD
- MENU STRUCTURE
- SETUP AND CONFIGURATION
- TIME-OUT AND SCREENSAVER
- ENTHALPY SETTINGS
- TWO-SPEED FAN OPERATION
- CHECKOUT
- TROUBLESHOOTING

Low Ambient Control (Factory Option) 50

Staged Air Volume (SAV) with Variable Frequency Drive (Factory Option) 50

PremierLink™ Control 50

RTU Open Control System 50

Wiring Diagrams 50

Smoke Detectors 67

- RETURN AIR SENSOR TUBE INSTALLATION
- SMOKE DETECTOR TEST MAGNET
- ADDITIONAL APPLICATION DATA

Step 12 — Adjust Factory-Installed Options 68

- ECONOMISER IV OCCUPANCY SWITCH

Step 13 — Install Accessories 68

Step 14 — Check Belt Tension 68

- BELT FORCE — DEFLECTION METHOD
- BELT TENSION METHOD

Pre-Start and Start-Up 69

START-UP CHECKLIST CL-1

SAFETY CONSIDERATIONS

Installation and servicing of air-conditioning equipment can be hazardous due to system pressure and electrical components. Only trained and qualified service personnel should install, repair, or service air-conditioning equipment.

Untrained personnel can perform basic maintenance functions of cleaning coils and filters and replacing filters. All other operations should be performed by trained service personnel. When working on air-conditioning equipment, observe precautions in the literature, tags and labels attached to the unit, and other safety precautions that may apply.

Follow all safety codes, including ANSI (American National Standards Institute) Z223.1. Wear safety glasses and work gloves. Use quenching cloth for unbrazing operations. Have fire extinguisher available for all brazing operations.

It is important to recognize safety information. This is the safety-alert symbol . When you see this symbol on the unit and in instructions or manuals, be alert to the potential for personal injury.

Understand the signal words DANGER, WARNING, CAUTION, and NOTE. These words are used with the safety-alert symbol. DANGER identifies the most serious hazards which **will** result in severe personal injury or death. WARNING signifies hazards which **could** result in personal injury or death. CAUTION is used to identify unsafe practices, which **may** result in minor personal injury or product and property damage. NOTE is used to highlight suggestions which **will** result in enhanced installation, reliability, or operation.

 **DANGER**

ELECTRICAL SHOCK HAZARD

Failure to follow this warning will result in personal injury or death.

Before performing service or maintenance operations on unit, turn off main power switch to unit and install lock(s) and lock-out tag(s). Ensure electrical service to rooftop unit agrees with voltage and amperage listed on the unit rating plate. Unit may have more than one power switch.

 **WARNING**

UNIT OPERATION AND SAFETY HAZARD

Failure to follow this warning could cause personal injury, death and/or equipment damage.

R-410A refrigerant systems operate at higher pressures than standard R-22 systems. Do not use R-22 service equipment or components on R-410A refrigerant equipment.

 **WARNING**

PERSONAL INJURY AND ENVIRONMENTAL HAZARD

Failure to follow this warning could cause personal injury or death.

Relieve pressure and recover all refrigerant before system repair or final unit disposal.

Wear safety glasses and gloves when handling refrigerants. Keep torches and other ignition sources away from refrigerants and oils.

 **CAUTION**

PERSONAL INJURY HAZARD

Failure to follow this caution may result in personal injury.

Sheet metal parts may have sharp edges or burrs. Use care and wear appropriate protective clothing, safety glasses and gloves when handling parts and servicing air conditioning equipment.

GENERAL

See Fig. 1 for unit options. See Fig. 2-16 for unit dimensions.

Rated Indoor Airflow (cfm)

The table below lists the rated indoor airflow used for the AHRI efficiency rating for the units covered in this document.

Table 1 — Rated Indoor Airflow

| MODEL NUMBER | FULL LOAD AIRFLOW (CFM) |
|--------------|-------------------------|
| 50HC*D17 | 4900 |
| 50HC*D20 | 5700 |
| 50HC*D24 | 6500 |
| 50HC*D28 | 8125 |

| | | | | | | | | | | | | | | | | | | |
|-----------|---|---|---|---|---|---|---|---|---|----|----|----|----|----|----|----|----|----|
| Position: | 1 | 2 | 3 | 4 | 5 | 6 | 7 | 8 | 9 | 10 | 11 | 12 | 13 | 14 | 15 | 16 | 17 | 18 |
| Example: | 5 | 0 | H | C | A | D | 2 | 4 | A | 3 | A | 5 | A | 0 | A | 0 | B | 0 |

Unit Heat Type

50 - Electric Heat
Packaged Rooftop

Model Series - WeatherMaster™

HC - High Efficiency

Electric Heat Options

- = Standard, No Electric Heat
A = Low Electric Heat
B = Medium Electric Heat
C = High Electric Heat

Refrig. Systems Options

D = Two stage cooling model
E = Two stage cooling models with Humidi-MiZer
G = Two stage cooling modles with Motor Master
Low Ambient Controller

Cooling Tons

17 - 15 tons
20 - 17.5 tons
24 - 20 tons
28 - 25 tons

Sensor Options

A = None
B = RA Smoke Detector
C = SA Smoke Detector
D = RA + SA Smoke Detector
E = CO₂
F = RA Smoke Detector and CO₂
G = SA Smoke Detector and CO₂
H = RA + SA Smoke Detector and CO₂

Indoor Fan Options

1 = Standard Static/Vertical Supply, Return Air Flow
2 = Medium Static/Vertical Supply, Return Air Flow
3 = High Static/Vertical Supply, Return Air Flow
B = Medium Static High Efficiency Motor/Vertical Supply, Return Air Flow
C = High Static High Efficiency Motor/Vertical Supply, Return Air Flow
5 = Standard Static/Horizontal Supply, Return Air Flow
6 = Medium Static/Horizontal Supply, Return Air Flow
7 = High Static/Horizontal Supply, Return Air Flow
F = Medium Static High Efficiency Motor/Horizontal Supply, Return Air Flow
G = High Static High Efficiency Motor/Horizontal Supply, Return Air Flow

Coil Options (RTPF) (Outdoor – Indoor – Hail Guard)

A = Al/Cu – Al/Cu
B = Precoat Al/Cu – Al/Cu
C = E-coat Al/Cu – Al/Cu
D = E-coat Al/Cu – E-coat Al/Cu
E = Cu/Cu – Al/Cu
F = Cu/Cu – Cu/Cu
M = Al/Cu – Al/Cu – Louvered Hail Guard
N = Precoat Al/Cu – Al/Cu – Louvered Hail Guard
P = E-coat Al/Cu – Al/Cu – Louvered Hail Guard
Q = E-coat Al/Cu – E-coat Al/Cu – Louvered Hail Guard
R = Cu/Cu – Al/Cu – Louvered Hail Guard
S = Cu/Cu – Cu/Cu – Louvered Hail Guard

Factory Assigned

0 = Standard
3 = California Seismic Compliant (OSHPD)

Electrical Options

A = None
B = HACR Breaker
C = Non-Fused Disconnect
G = 2-Speed Indoor Fan (VFD) Controller
H = 2-Speed Fan Controller (VFD) and HACR
J = 2 Speed Fan Controller and Non-Fused Disconnect

Service Options

0 = None
1 = Unpowered Convenience Outlet
2 = Powered Convenience Outlet
3 = Hinged Panels
4 = Hinged Panels and Unpowered Convenience Outlet
5 = Hinged Panels and Powered Convenience Outlet
C = Foil Faced Insulation
D = Foil Faced Insulation with Unpowered Convenience Outlet
E = Foil Faced Insulation with Powered Convenience Outlet
F = Foil Faced Insulation & Hinged Panels
G = Foil Faced Insulation & Hinged Panels with Unpowered Convenience Outlet
H = Foil Faced Insulation & Hinged Panels with Powered Convenience Outlet

Intake / Exhaust Options

A = None
B = Temperature Economizer w/ Barometric Relief
F = Enthalpy Economizer w/ Barometric Relief
K = 2-Position Damper
U = Temp Ultra Low Leak Economizer w/ Baro Relief
W = Enthalpy Ultra Low Leak Economizer w/ Baro Relief

Base Unit Controls

0 = Base Electromechanical Controls
1 = PremierLink Controller
2 = RTU Open Multi-Protocol Controller
6 = Electro-mechanical w/ 2-Speed Fan and W7220 Economizer Controller
D = ComfortLink Controls

Design Revision

A = Factory Design Revision

Voltage

1 = 575/3/60
5 = 208-230/3/60
6 = 460/3/60

Fig. 1 — 50HC 17-28 Model Number Nomenclature

| CONNECTION SIZES | |
|------------------|--|
| A | 1 3/8" DIA [351] FIELD POWER SUPPLY KNOCKOUT |
| B | 3" DIA [76] FIELD POWER SUPPLY KNOCKOUT |
| C | 3 5/8" DIA [92] FIELD POWER SUPPLY KNOCKOUT |
| D | 7/8" DIA [22] FIELD CONTROL WIRING HOLE |
| G | 7/8" DIA [22] FIELD CONTROL WIRING KNOCKOUT |

NOTES:

1. DIMENSIONS ARE IN INCHES. DIMENSIONS IN [] ARE IN MILLIMETERS.
2. CENTER OF GRAVITY
3. DIRECTION OF AIR FLOW
4. ALL VIEW DRAWN USING 3RD ANGLE

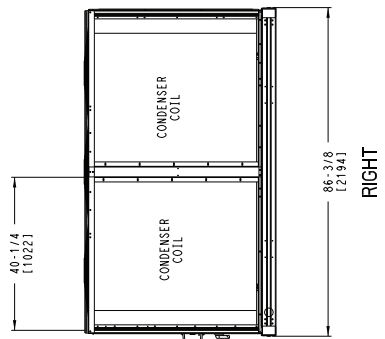
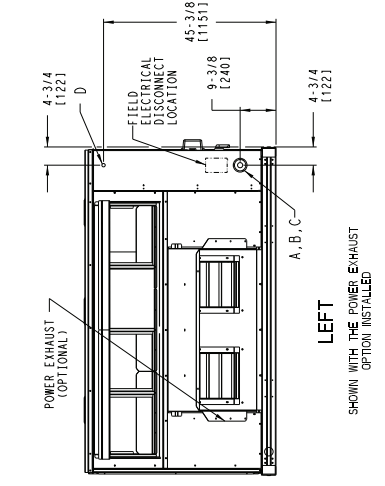
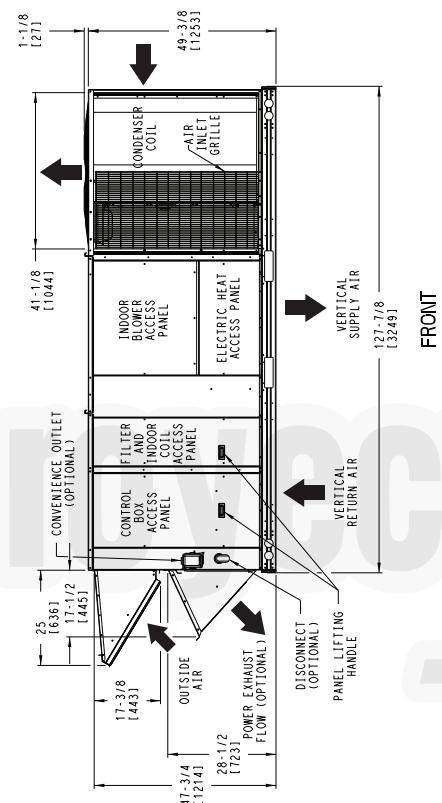
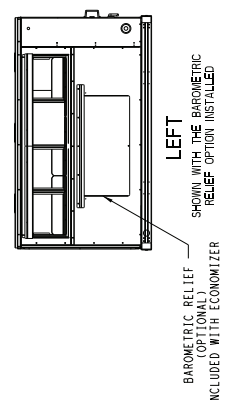
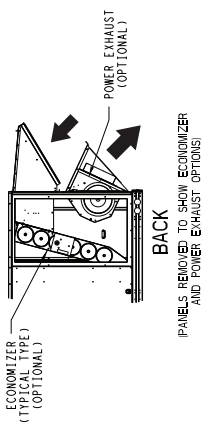
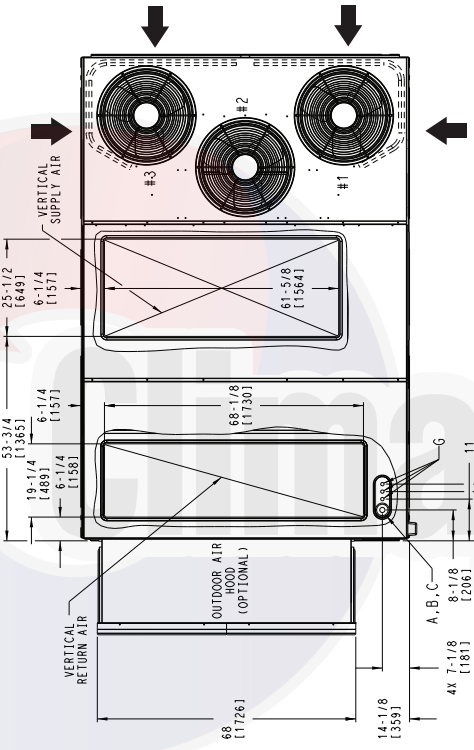

DEDICATED VERTICAL AIRFLOW UNIT

| TIC CLASSIFICATION | SHEET | DATE | SUPERSEDES | REV |
|--------------------|--------|----------|---|-----|
| U.S. ECCN: NSR | 1 OF 5 | 02/08/19 | 50HC 17 SINGLE ZONE ELECTRICAL COOLING WITH ELECTRIC HEAT | B |

Fig. 2 — 50HC**17 Vertical Airflow

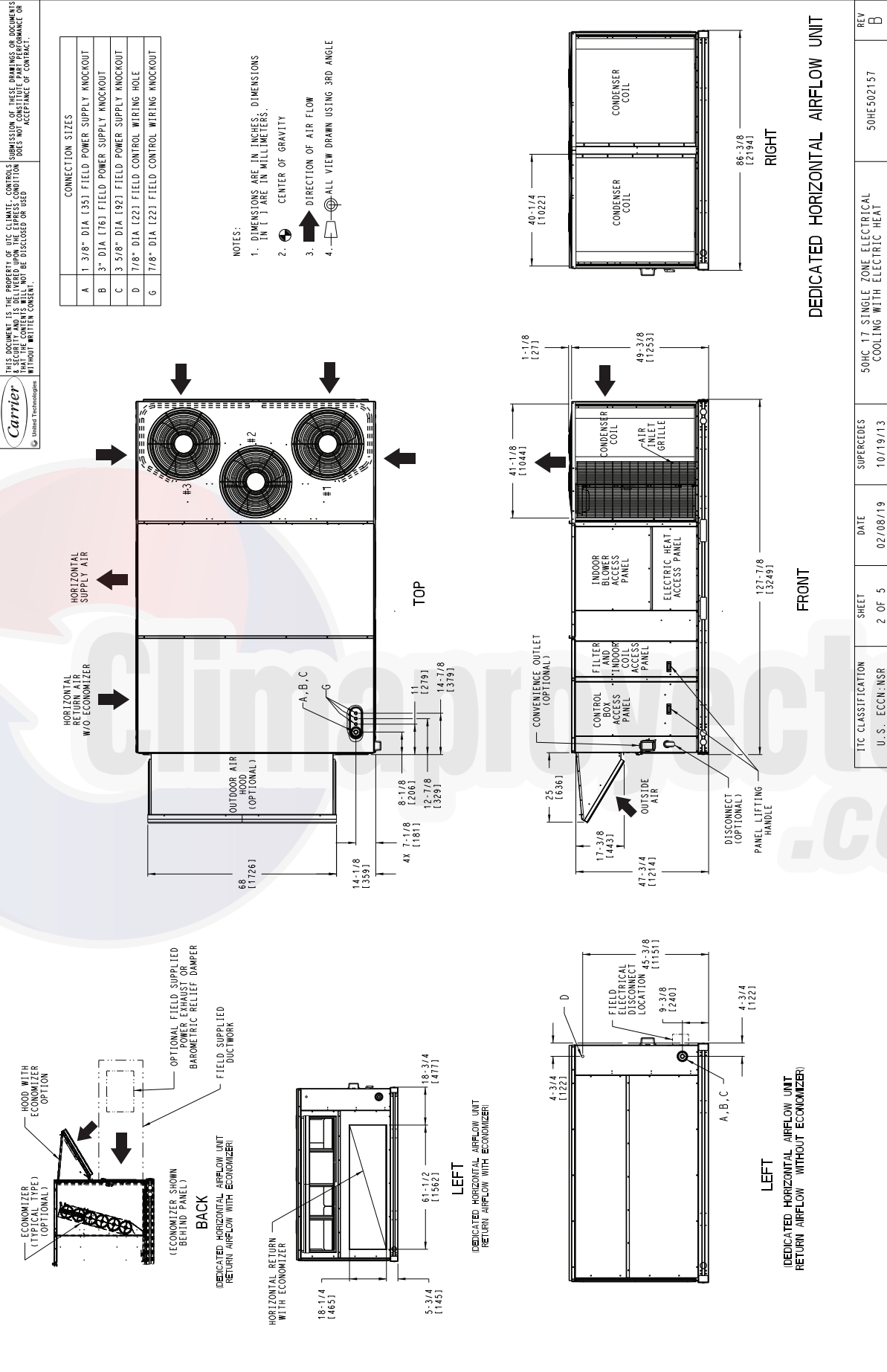

Fig. 3 — 50HC**17 Horizontal Airflow

| | | | | |
|---|--------|----------|------------|------------|
| TIC CLASSIFICATION | SHEET | DATE | SUPERSEDES | REV |
| U.S. ECCN: NSR | 2 OF 5 | 02/08/19 | 10/19/13 | B |
| 50HC 17 SINGLE ZONE ELECTRICAL COOLING WITH ELECTRIC HEAT | | | | 50HE502157 |

DEDICATED HORIZONTAL AIRFLOW UNIT

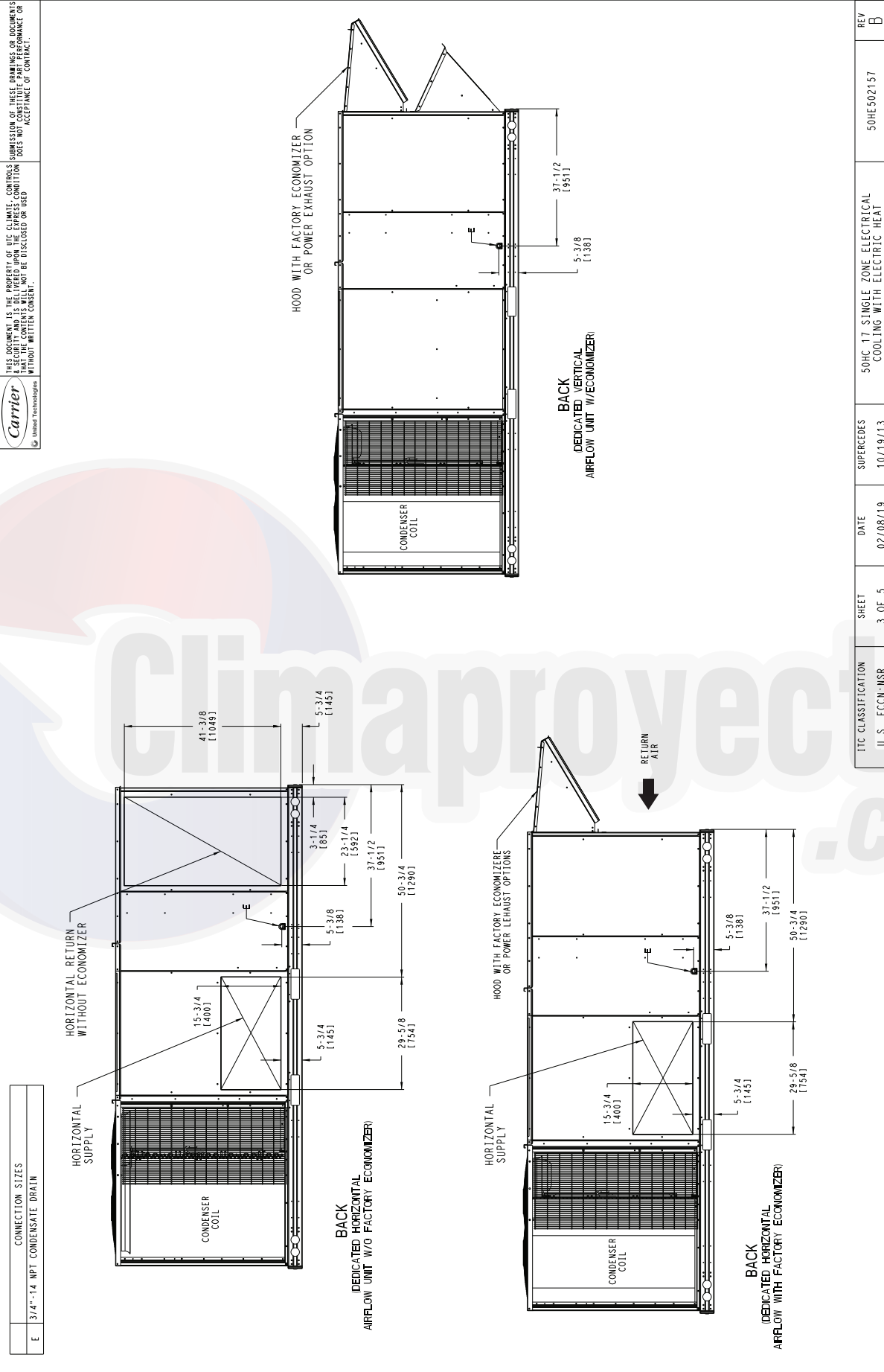
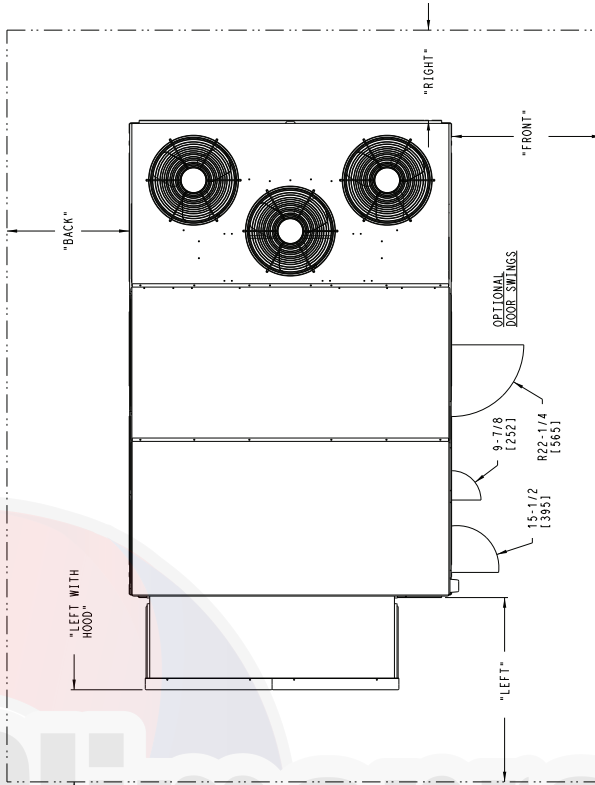

Fig. 4 — 50HC**17 Back View and Condensate Drain Location

| UNIT | STD. UNIT WEIGHT | | CORNER WEIGHT (A) | | CORNER WEIGHT (B) | | CORNER WEIGHT (C) | | CORNER WEIGHT (D) | | C. G. | | | | | | | |
|--------|------------------|-----|-------------------|-----|-------------------|-----|-------------------|-----|-------------------|-----|-------|------|----|-----|------|----|-----|-----|
| | LBS. | KG. | LBS. | KG. | LBS. | KG. | LBS. | KG. | LBS. | KG. | X | Y | Z | | | | | |
| 50HC17 | 1793 | 815 | 375 | 170 | 419 | 191 | 528 | 240 | 472 | 214 | 48 | 1219 | 67 | 378 | 1711 | 16 | 1/2 | 419 |

* STANDARD UNIT WEIGHT IS WITHOUT ELECTRIC HEAT AND WITHOUT PACKAGING. FOR OTHER OPTIONS AND ACCESSORIES, REFER TO THE PRODUCT DATA CATALOG.



NOTES:

- CLEARANCE ABOVE THE UNIT TO BE 72"
- FOR ALL MINIMUM CLEARANCES LOCAL CODES OR JURISDICTIONS MAY PREVAIL.

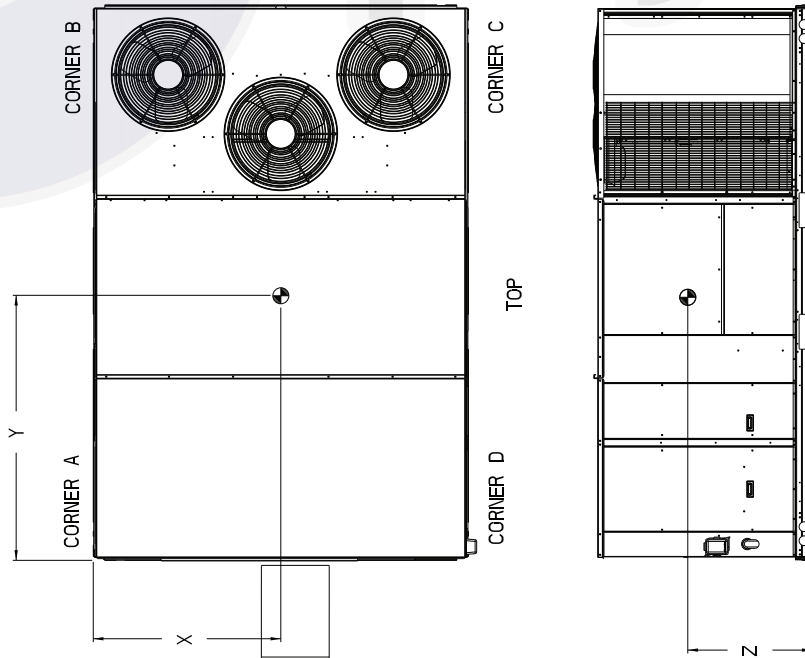

| SURFACE | CLEARANCE | | OPERATING CLEARANCE | |
|----------------|---------------------------------|------------------------------------|---------------------------------|------------------------------------|
| | SERVICE WITH CONDUCTIVE BARRIER | SERVICE WITH NONCONDUCTIVE BARRIER | SERVICE WITH CONDUCTIVE BARRIER | SERVICE WITH NONCONDUCTIVE BARRIER |
| FRONT | 48 [1219mm] | 36 [914mm] | 18 [457mm] | 18 [457mm] |
| BACK | 42 [1067mm] | 42 [1067mm] | 18 [457mm] | 18 [457mm] |
| LEFT WITH HOOD | 36 [914mm] | 36 [914mm] | 18 [457mm] | 18 [457mm] |
| RIGHT | 36 [914mm] | 36 [914mm] | 18 [457mm] | 18 [457mm] |
| TOP | 72 [1829mm] | 72 [1829mm] | 72 [1829mm] | 72 [1829mm] |

| TIC CLASSIFICATION | SHEET | DATE | REV |
|---|--------|----------|------------|
| U.S. ECCN: NSR | 4 OF 5 | 02/08/19 | 50HC502157 |
| 50HC 17 SINGLE ZONE ELECTRICAL COOLING WITH ELECTRIC HEAT | | | B |

Fig. 5 — 50HC**17 Corner Weights and Clearances

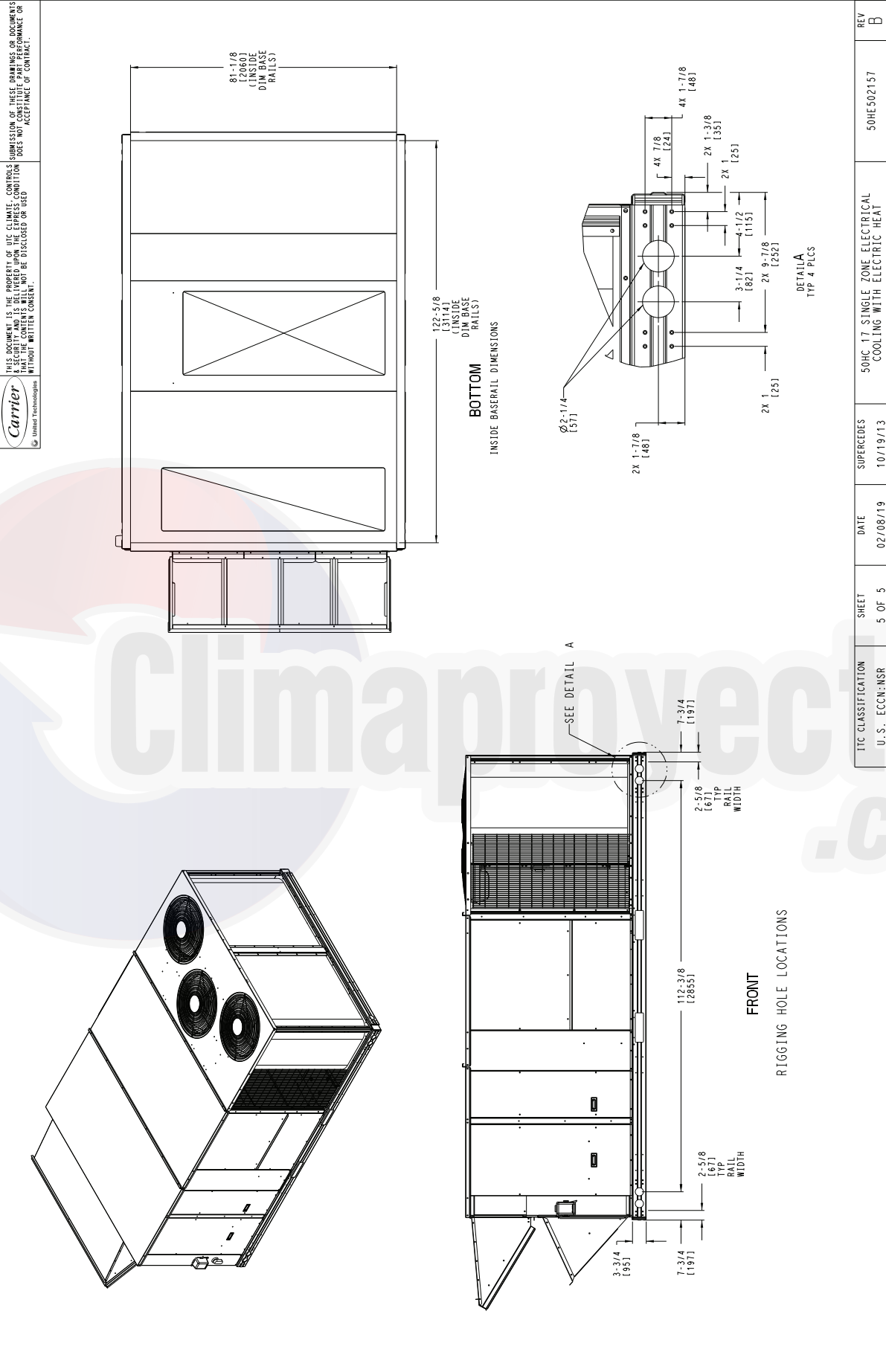

| | | | | | | |
|--------------------------------------|-----------------|------------------|------------------------|--|------------|----------|
| TIC CLASSIFICATION U.S. ECCN: NSR | SHEET 5 OF 5 | DATE 02/08/19 | SUPERSEDES 10/19/13 | 50HC 17 SINGLE ZONE ELECTRICAL COOLING WITH ELECTRIC HEAT | 50HE502157 | REV B |
|--------------------------------------|-----------------|------------------|------------------------|--|------------|----------|

Fig. 6 — 50HC**17 Bottom View

THIS DOCUMENT IS THE PROPERTY OF UTC CLIMATE, CONTROLS SUBMISSION OF THESE DRAWINGS OR DOCUMENTS WITHOUT WRITTEN CONSENT. THE CONTENTS WILL NOT BE DISCLOSED OR REPRODUCED IN ANY MANNER WITHOUT WRITTEN CONSENT.



| CONNECTION SIZES | |
|------------------|---|
| A | 1 3/8" DIA [35] FIELD POWER SUPPLY KNOCKOUT |
| B | 3" DIA [76] FIELD POWER SUPPLY KNOCKOUT |
| C | 3 5/8" DIA [92] FIELD POWER SUPPLY KNOCKOUT |
| D | 7/8" DIA [22] FIELD CONTROL WIRING HOLE |
| G | 7/8" DIA [22] FIELD CONTROL WIRING KNOCKOUT |

| UNIT | H |
|----------------|--------|
| 20 SIZE [1253] | 49-3/8 |
| 24 SIZE [1456] | 57-3/8 |

- NOTES:
1. DIMENSIONS ARE IN INCHES. DIMENSIONS IN [] ARE IN MILLIMETERS.
 2. CENTER OF GRAVITY
 3. DIRECTION OF AIR FLOW
 4. ALL VIEW DRAWN USING 3RD ANGLE

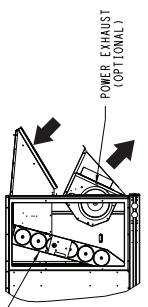
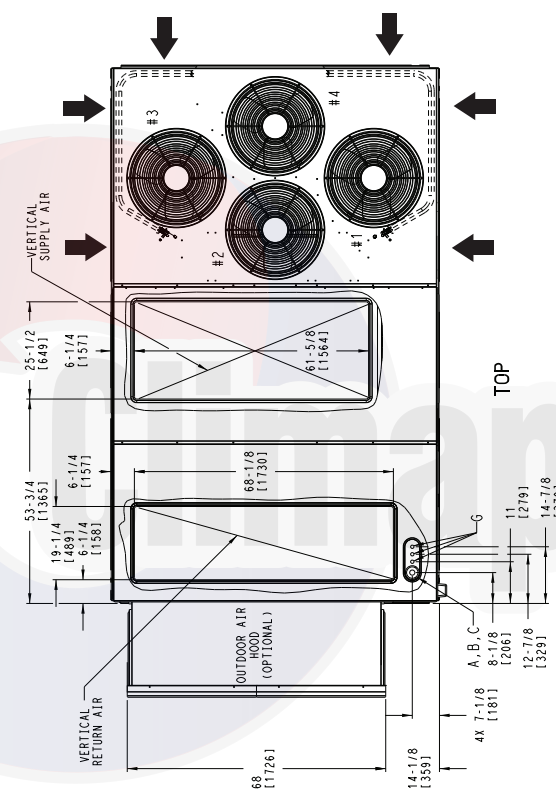

BACK
(PANELS REMOVED TO SHOW ECONOMIZER AND POWER EXHAUST OPTIONS)

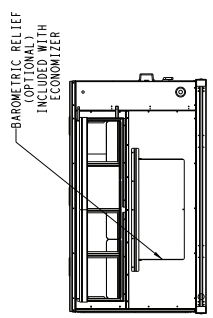

LEFT
SHOWN WITH THE BAROMETRIC RELIEF OPTION INSTALLED

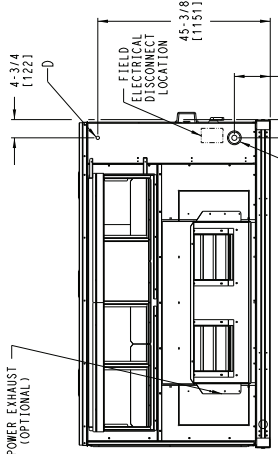

LEFT
SHOWN WITH THE POWER EXHAUST OPTION INSTALLED

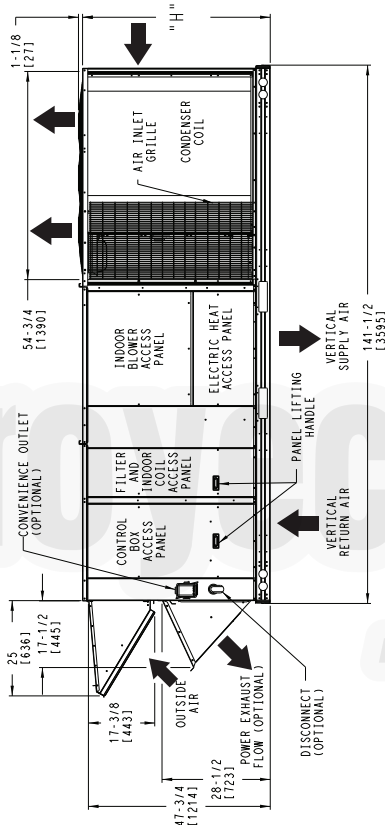

FRONT

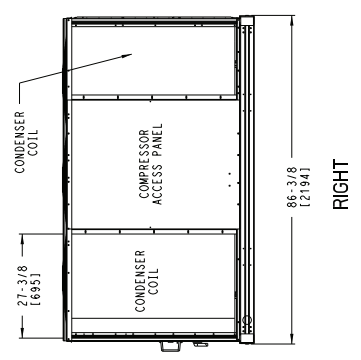

DEDICATED VERTICAL AIRFLOW UNIT

| U.S. ECON. NSR | SHEET | DATE | SUPERSEDES | REV |
|----------------|----------|----------|--|-----|
| 1 OF 5 | 10/19/13 | 02/09/19 | 50HC 20,24 SINGLE ZONE ELECTRICAL COOLING WITH ELECTRIC HEAT | C |

Fig. 7 — 50HC**20-24 Vertical Airflow

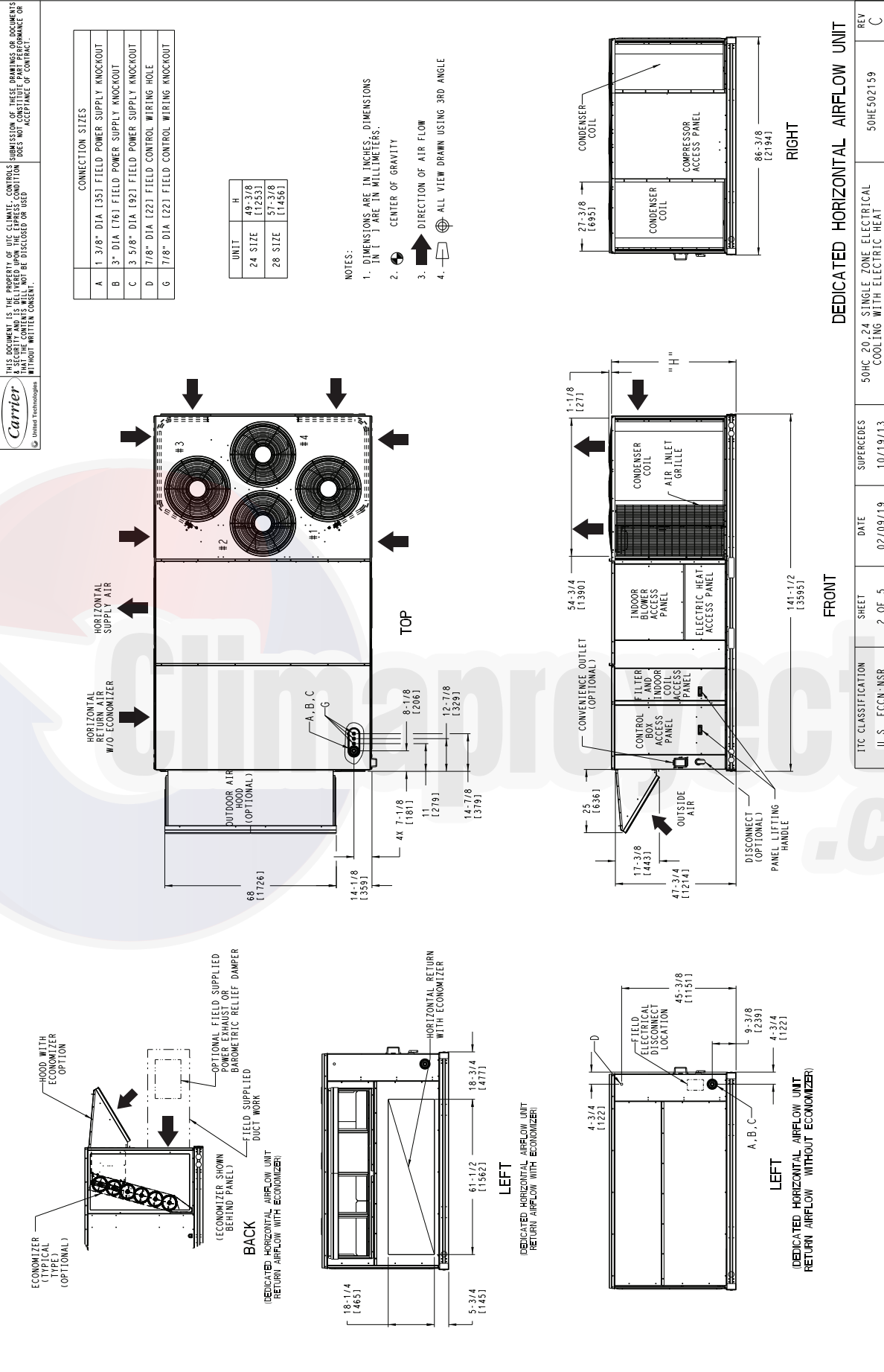
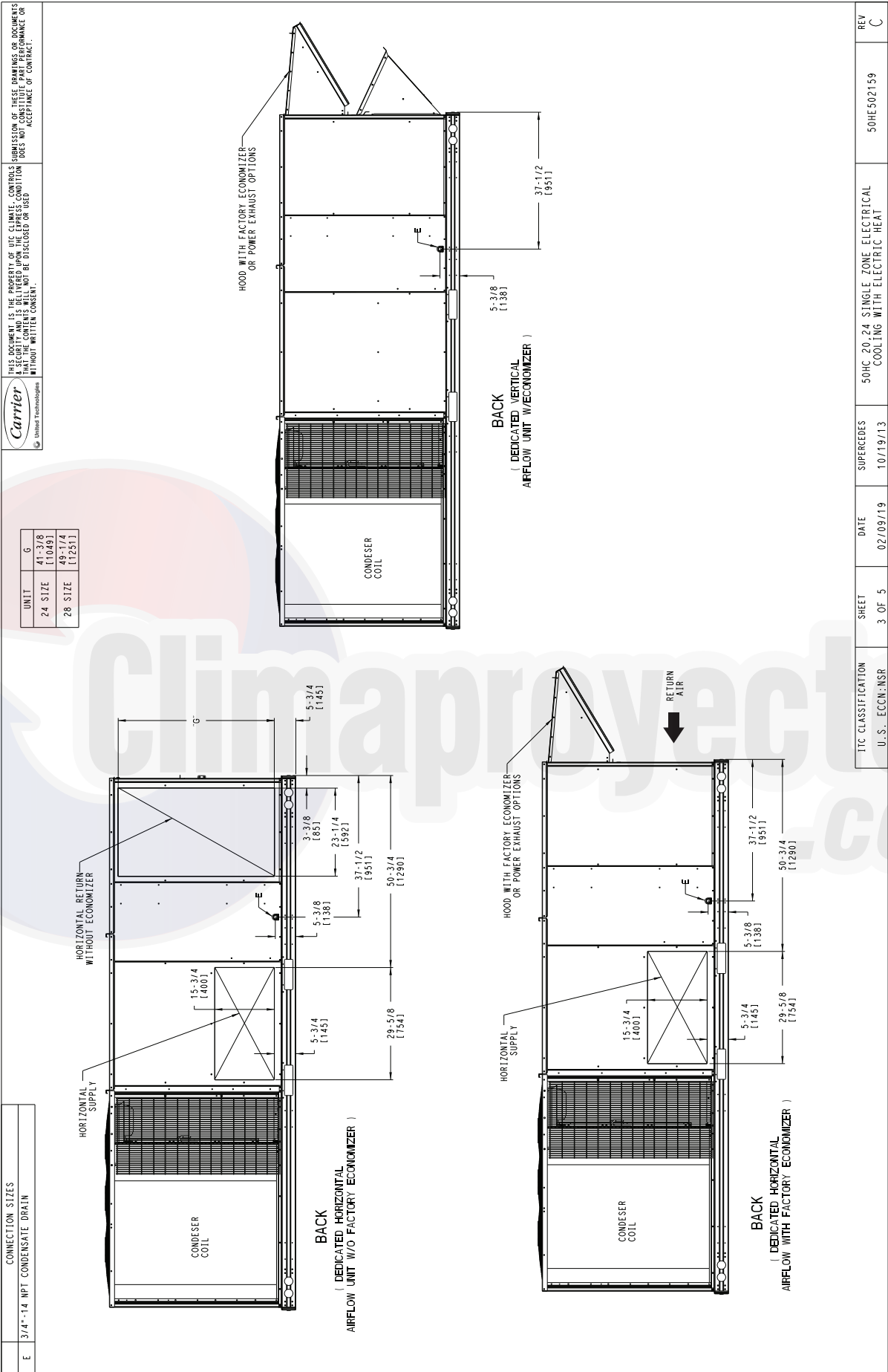

Fig. 8 — 50HC**20-24 Horizontal Airflow



| | | | | |
|---------------------|--------|----------|--|-----|
| U.S. CLASSIFICATION | SHEET | DATE | SUPERSEDES | REV |
| U.S. ECON: NSR | 3 OF 5 | 02/09/19 | 10/19/13 | C |
| | | | 50HC 20,24 SINGLE ZONE ELECTRICAL COOLING WITH ELECTRIC HEAT | |
| | | | 50HE502159 | |

Fig. 9 — 50HC**20-24 Back View and Condensate Drain Location

| UNIT | STD. UNIT WEIGHT * | | CORNER WEIGHT (A) | | CORNER WEIGHT (B) | | CORNER WEIGHT (C) | | CORNER WEIGHT (D) | | C.G. | | | | | |
|--------|--------------------|-----|-------------------|-----|-------------------|-----|-------------------|-----|-------------------|-----|------|------------|----|------------|----|-----------|
| | LBS. | KG. | LBS. | KG. | LBS. | KG. | LBS. | KG. | LBS. | KG. | X | Y | Z | | | |
| 50HC20 | 2003 | 911 | 445 | 202 | 367 | 167 | 557 | 253 | 547 | 249 | 47 | 1/2 [1207] | 71 | 1/4 [1810] | 16 | 1/2 [419] |
| 50HC24 | 2148 | 976 | 510 | 232 | 525 | 238 | 564 | 257 | 549 | 250 | 44 | 5/8 [1133] | 71 | 5/8 [1819] | 19 | [483] |

* STANDARD UNIT WEIGHT IS WITHOUT ELECTRIC HEAT AND WITHOUT PACKAGING. FOR OTHER OPTIONS AND ACCESSORIES, REFER TO THE PRODUCT DATA CATALOG.

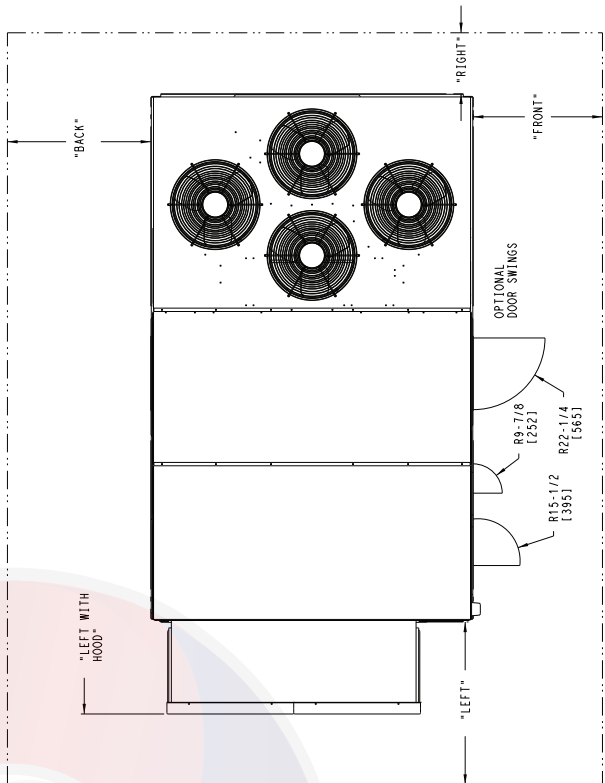

- NOTES:
- CLEARANCE ABOVE THE UNIT TO BE 72"
 - FOR ALL MINIMUM CLEARANCES LOCAL CODES OR JURISDICTIONS MAY PREVAIL.

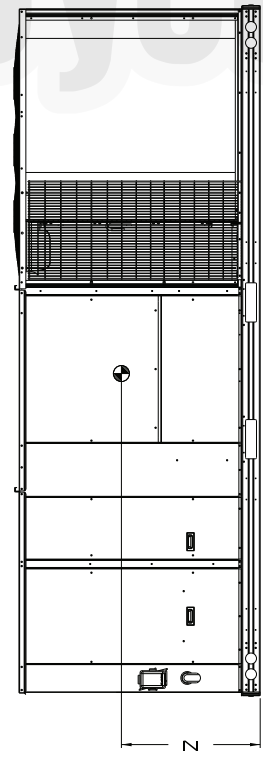

| SURFACE | CLEARANCE | | |
|----------------|---------------------------------|------------------------------------|---------------------|
| | SERVICE WITH CONDUCTIVE BARRIER | SERVICE WITH NONCONDUCTIVE BARRIER | OPERATING CLEARANCE |
| FRONT | 48 [1219mm] | 36 [914mm] | 18 [457mm] |
| BACK | 42 [1106.7mm] | 42 [1106.7mm] | 18 [457mm] |
| LEFT WITH HOOD | 36 [914mm] | 36 [914mm] | 18 [457mm] |
| RIGHT | 36 [914mm] | 36 [914mm] | 18 [457mm] |
| TOP | 72 [1829mm] | 72 [1829mm] | 72 [1829mm] |

| | | | |
|--|--------|----------|------------|
| TIC CLASSIFICATION | SHEET | DATE | REV |
| U.S. ECCN: NSR | 4 OF 5 | 02/09/19 | 50HC502159 |
| SUPERCEDES | | | C |
| 50HC 20,24 SINGLE ZONE ELECTRICAL COOLING WITH ELECTRIC HEAT | | | |

Fig. 10 — 50HC**20-24 Corner Weights and Clearances

 THIS DOCUMENT IS THE PROPERTY OF UTC CLIMATE-CONTROL. SUBMISSION OF THESE DRAWINGS OR DOCUMENTS IN ANY FORM OR BY ANY MEANS, WITHOUT WRITTEN CONSENT, DOES NOT CONSTITUTE PART PERFORMANCE OR ACCEPTANCE OF CONTRACT.

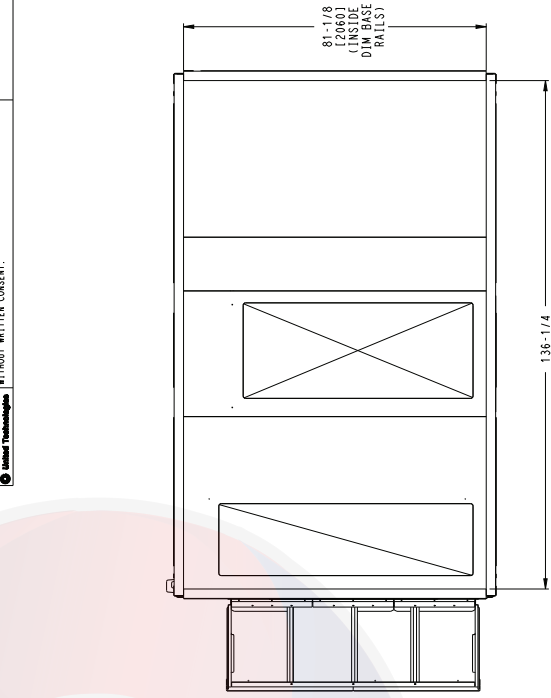

BOTTOM
INSIDE BASERAIL DIMENSIONS

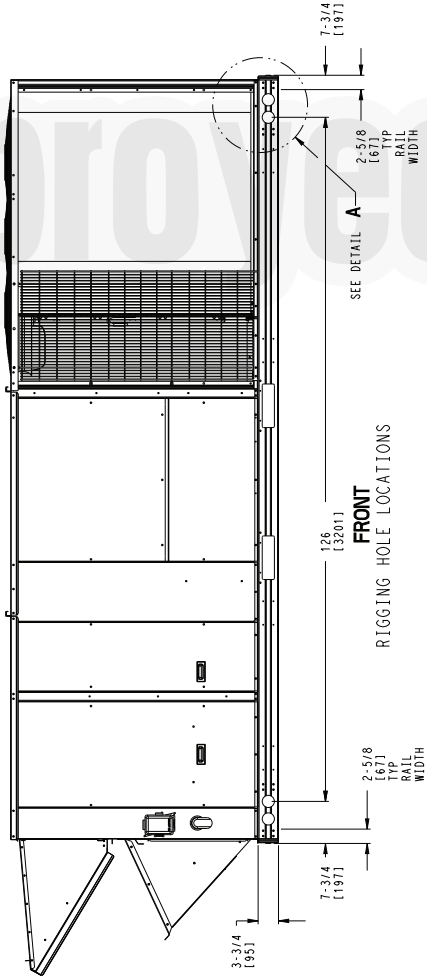
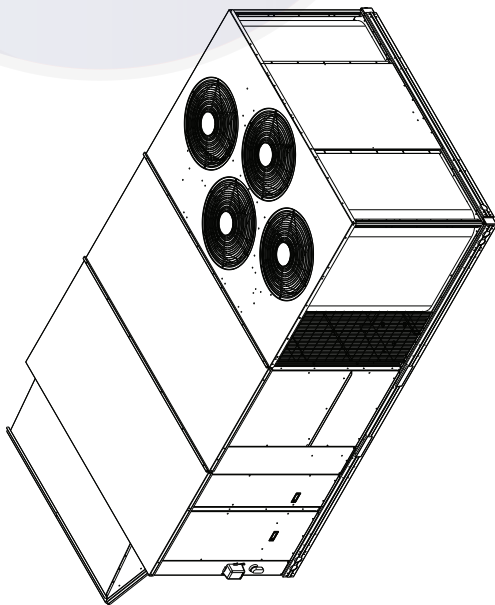
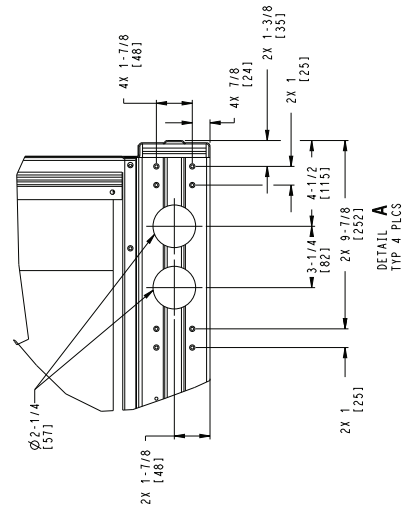

| | | | | | | |
|--------------------------------------|-----------------|------------------|------------------------|---|------------|----------|
| TIC CLASSIFICATION U.S. ECCN: NSR | SHEET 5 OF 5 | DATE 02/09/19 | SUPERSEDES 10/19/13 | 50HC 20,24 SINGLE ZONE ELECTRICAL COOLING WITH ELECTRIC HEAT | 50HC502159 | REV C |
|--------------------------------------|-----------------|------------------|------------------------|---|------------|----------|

Fig. 11 — 50HC**20-24 Bottom View

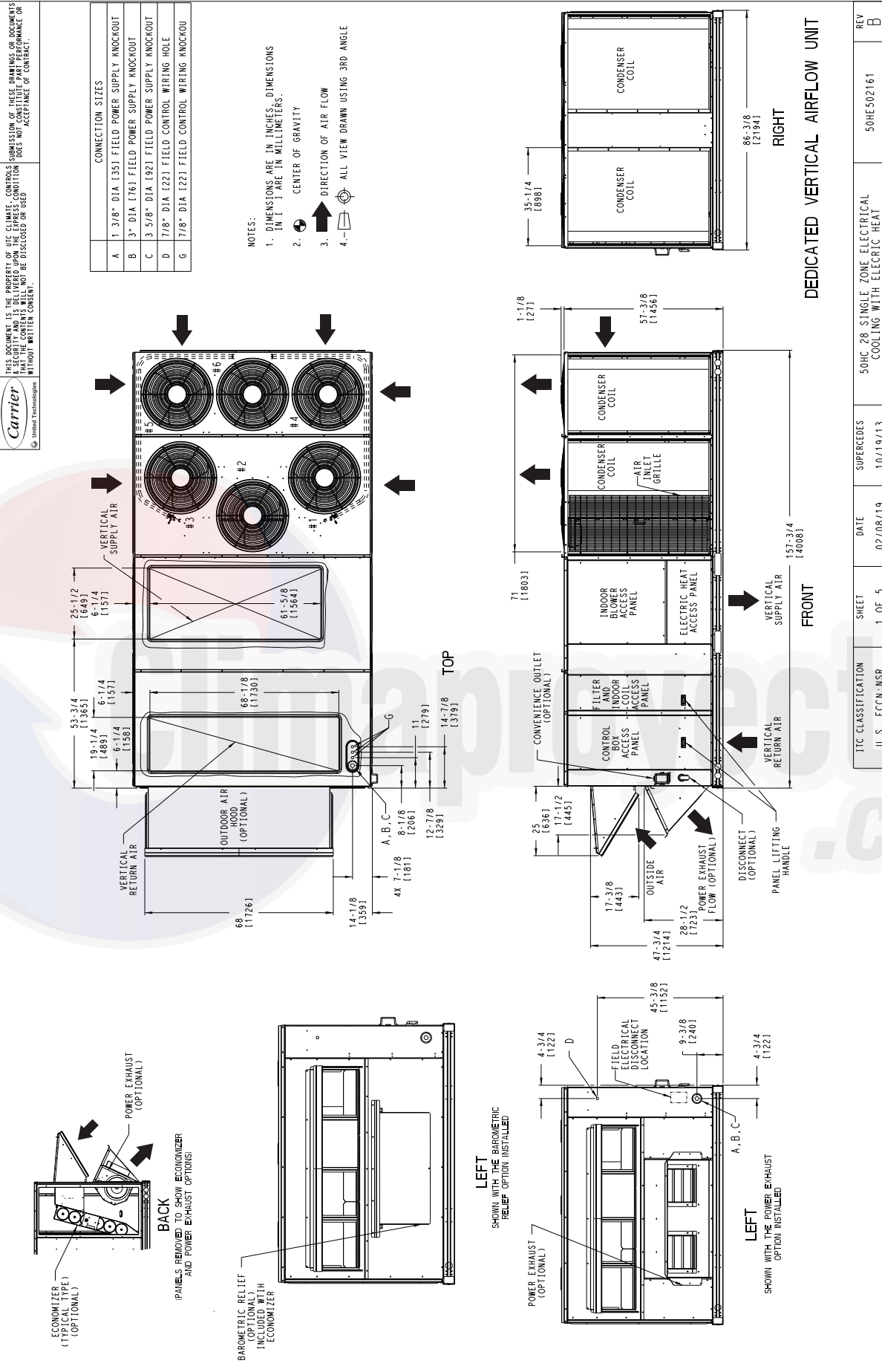
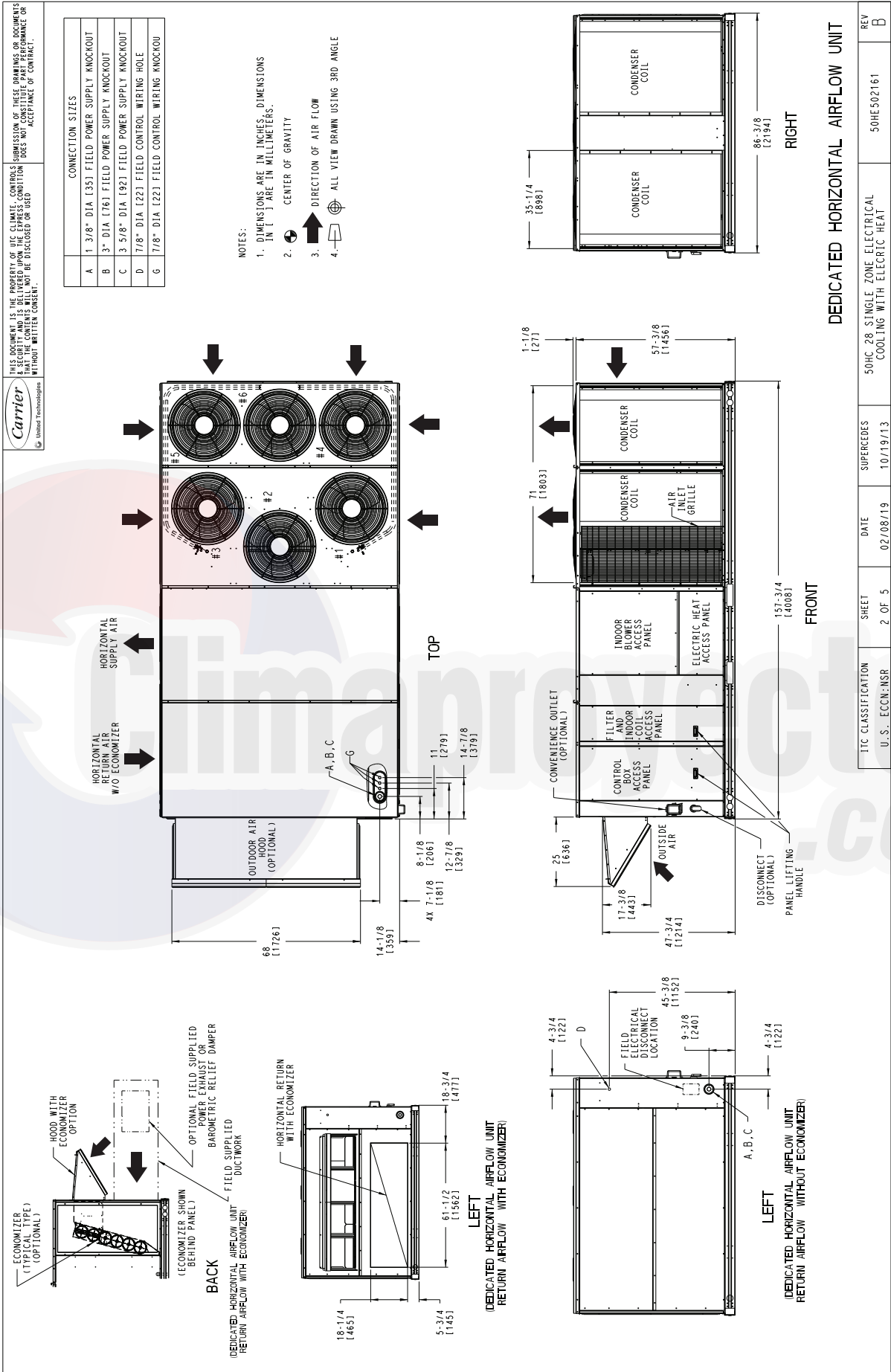

Fig. 12 — 50HC**28 Vertical Airflow



DEDICATED HORIZONTAL AIRFLOW UNIT

| | | | | |
|---|--------|----------|------------|------------|
| TIC CLASSIFICATION | SHEET | DATE | SUPERSEDES | REV |
| U.S. ECCN: NSR | 2 OF 5 | 02/08/19 | 10/19/13 | B |
| 50HC 28 SINGLE ZONE ELECTRICAL COOLING WITH ELECTRIC HEAT | | | | 50HE502161 |

Fig. 13 — 50HC28 Horizontal Airflow**

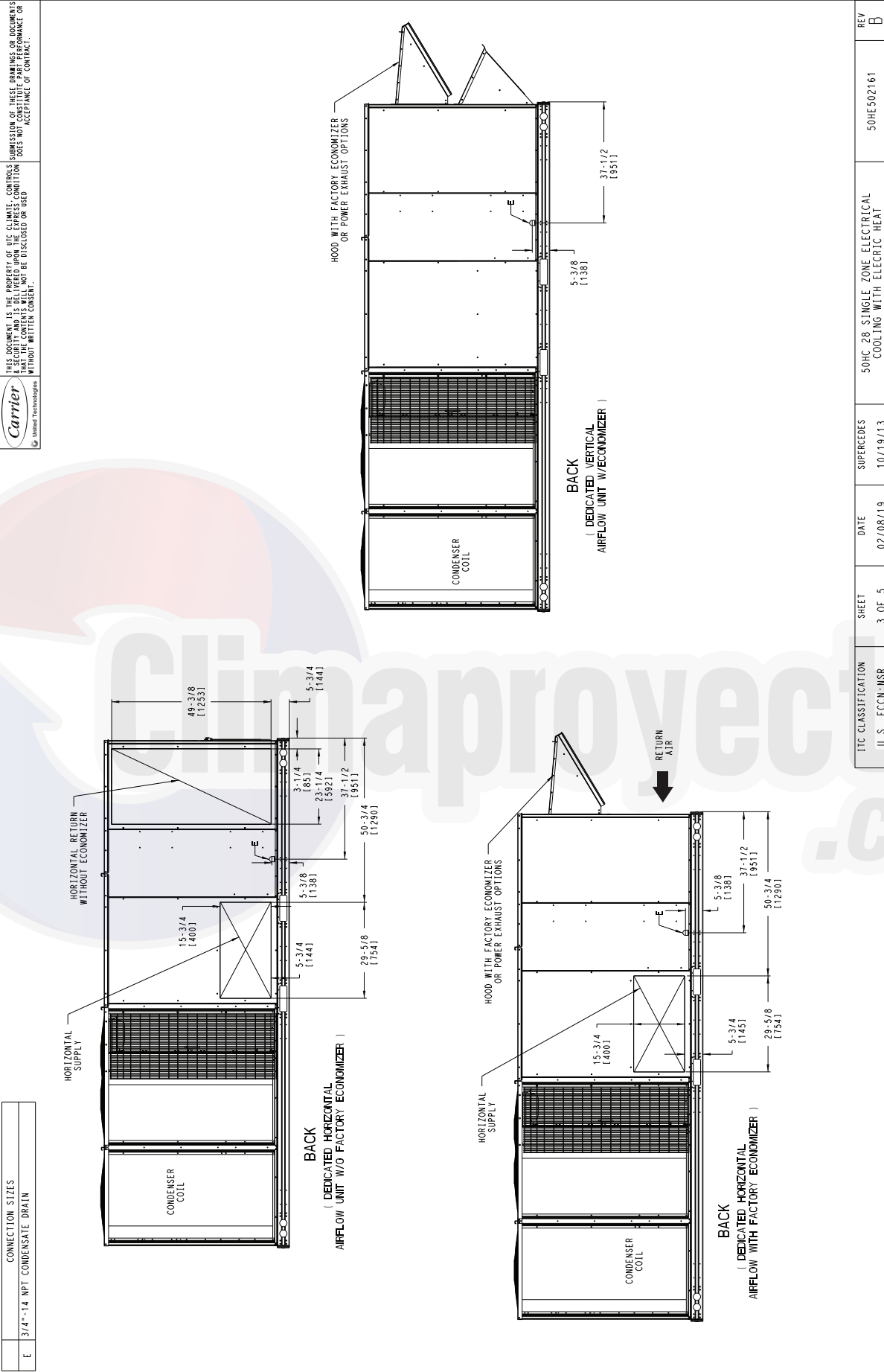

| | | | | | |
|--------------------------------------|-----------------|------------------|------------------------|--|----------|
| TIC CLASSIFICATION U.S. ECCN: NSR | SHEET 3 OF 5 | DATE 02/08/19 | SUPERSEDES 10/19/13 | 50HC 28 SINGLE ZONE ELECTRICAL COOLING WITH ELECTRIC HEAT | REV B |
|--------------------------------------|-----------------|------------------|------------------------|--|----------|

Fig. 14 — 50HC**28 Back View and Condensate Drain Location

THIS DOCUMENT IS THE PROPERTY OF UTC CLIMATE CONTROLS. SUBMISSION OF THESE DRAWINGS OR DOCUMENTS WITHOUT WRITTEN CONSENT. THE CONTENTS WILL NOT BE DISCLOSED OR REPRODUCED WITHOUT WRITTEN CONSENT.



| UNIT | CORNER WEIGHT (A) | | CORNER WEIGHT (B) | | CORNER WEIGHT (C) | | CORNER WEIGHT (D) | | C.G. | | | | |
|--------|-------------------|-----|-------------------|-----|-------------------|-----|-------------------|-----|------|-----|-------------|---------------|----------|
| | LBS. | KG. | LBS. | KG. | LBS. | KG. | LBS. | KG. | | | | | |
| 50HC28 | 2193 | 997 | 545 | 248 | 528 | 240 | 551 | 251 | 569 | 259 | X | Y | Z |
| | | | | | | | | | | | 44 [111.81] | 77 1/2 [1969] | 19 [483] |

* STANDARD UNIT WEIGHT IS WITHOUT ELECTRIC HEAT AND WITHOUT PACKAGING. FOR OTHER OPTIONS AND ACCESSORIES, REFER TO THE PRODUCT DATA CATALOG.

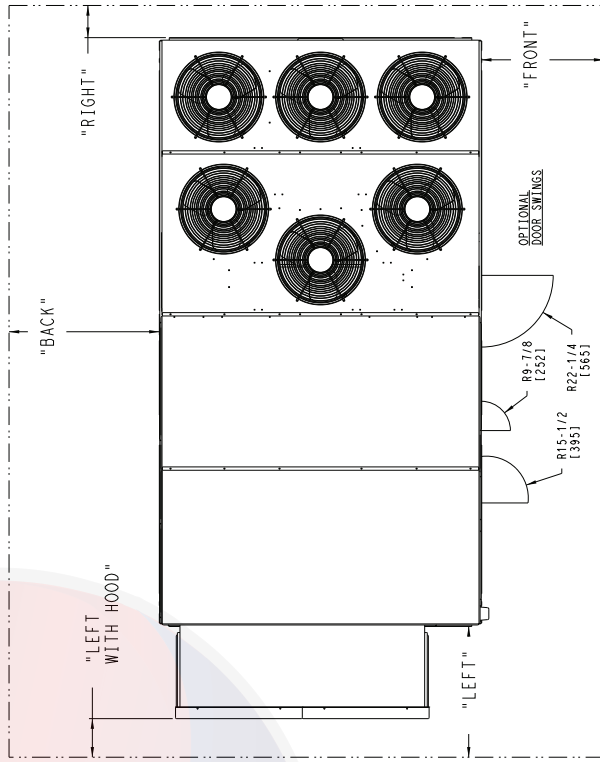

NOTES:

- CLEARANCE ABOVE THE UNIT TO BE 72"
- FOR ALL MINIMUM CLEARANCES LOCAL CODES OR JURISDICTIONS MAY PREVAIL.

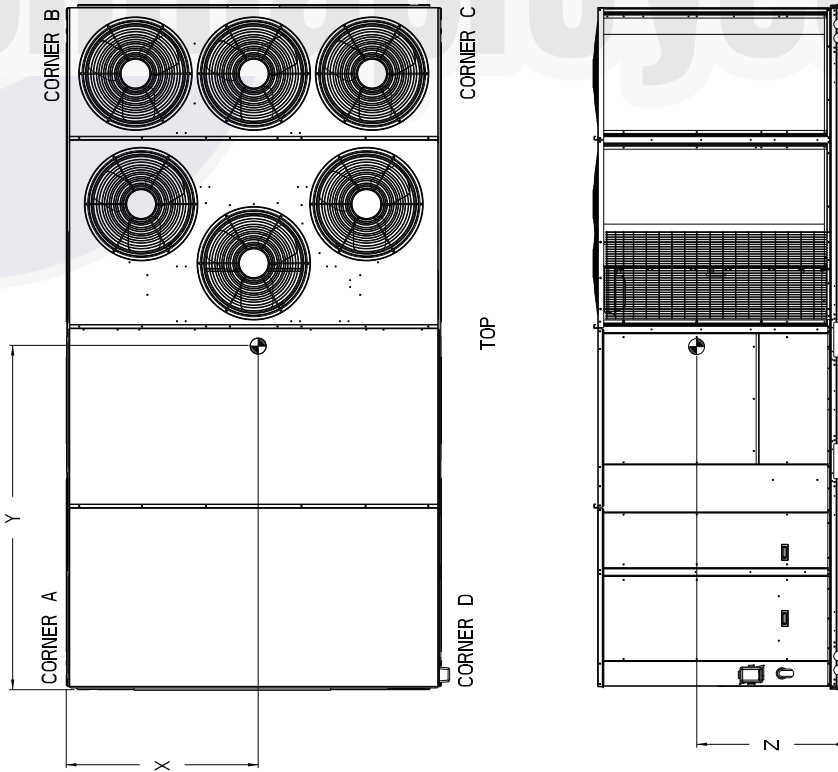

| SURFACE | CLEARANCE | | OPERATING CLEARANCE | |
|----------------|---------------------------------|------------------------------------|---------------------------------|------------------------------------|
| | SERVICE WITH CONDUCTIVE BARRIER | SERVICE WITH NONCONDUCTIVE BARRIER | SERVICE WITH CONDUCTIVE BARRIER | SERVICE WITH NONCONDUCTIVE BARRIER |
| FRONT | 48 [1219mm] | 36 [914mm] | 18 [457mm] | 18 [457mm] |
| LEFT | 48 [1219mm] | 42 [1067mm] | 18 [457mm] | 18 [457mm] |
| BACK | 42 [1067mm] | 36 [914mm] | 18 [457mm] | 18 [457mm] |
| LEFT WITH HOOD | 36 [914mm] | 36 [914mm] | 18 [457mm] | 18 [457mm] |
| RIGHT | 36 [914mm] | 36 [914mm] | 18 [457mm] | 18 [457mm] |
| TOP | 72 [1829mm] | 72 [1829mm] | 72 [1829mm] | 72 [1829mm] |

| | | | |
|---|--------|----------|------------|
| TIC CLASSIFICATION | SHEET | DATE | REV |
| 50HC 28 SINGLE ZONE ELECTRICAL COOLING WITH ELECTRIC HEAT | 4 OF 5 | 02/08/19 | B |
| U.S. ECCN: NSR | | | 50HC502161 |

Fig. 15 — 50HC**28 Corner Weights and Clearances

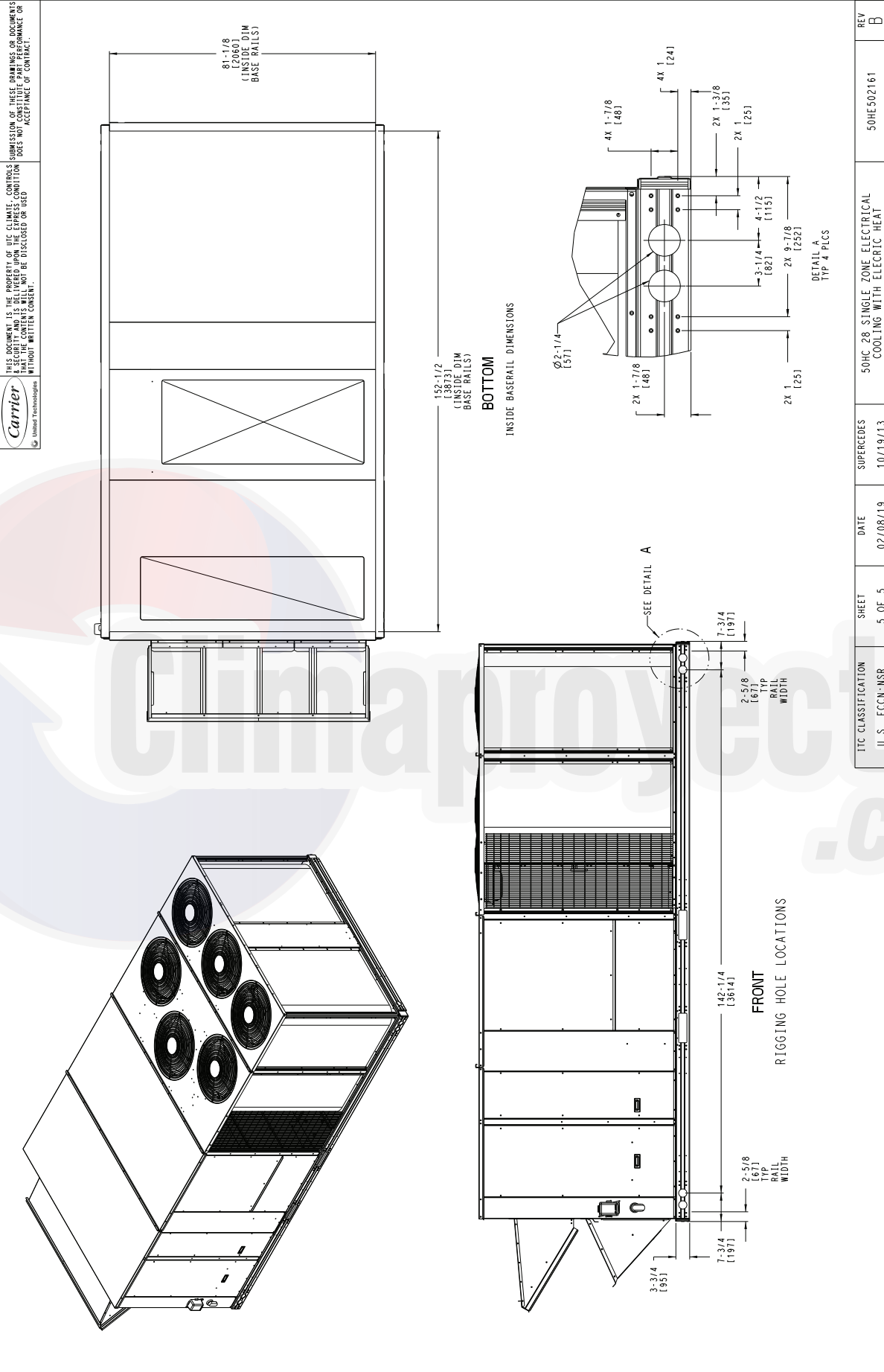

Fig. 16 — 50HC**28 Bottom View

INSTALLATION

Jobsite Survey

Complete the following checks before installation.

1. Consult local building codes and the NEC (National Electrical Code) ANSI/NFPA 70 for special installation requirements.
2. Determine unit location (from project plans) or select unit location.
3. Check for possible overhead obstructions which may interfere with unit lifting or rigging.

Step 1 — Plan for Unit Location

Select a location for the unit and its support system (curb or other) that provides for at least the minimum clearances required for safety. This includes the clearance to combustible surfaces, unit performance and service access below, around and above unit as specified in unit drawings. See Fig. 5, 10, and 15.

NOTE: Consider also the effect of adjacent units.

Be sure that the unit is installed such that snow will not block the combustion air intake or flue outlet.

Unit may be installed directly on wood flooring or on Class A, B, or C roof-covering material when roof curb is used.

Do not install unit in an indoor location. Do not locate air inlets near exhaust vents, relief valves, or other sources of contaminated air.

Although unit is weatherproof, avoid locations that permit water from higher level runoff and overhangs to fall onto the unit.

Select a unit mounting system that provides adequate height to allow installation of condensate trap per requirements. Refer to Step 9 — Install External Condensate Trap and Line for required trap dimensions.

ROOF MOUNT

Check building codes for weight distribution requirements. Unit operating weight is shown in Table 2.

Step 2 — Plan for Sequence of Unit Installation

The support method used for this unit will dictate different sequences for the steps of unit installation. For example, on curb-mounted units, some accessories must be installed on the unit before the unit is placed on the curb. Review the following for recommended sequences for installation steps.

CURB-MOUNTED INSTALLATION

1. Install curb
2. Install field-fabricated ductwork inside curb
3. Install accessory thru-base service connection package (affects curb and unit)
4. Rig and place unit
5. Remove top skid

6. Install outside air hood
7. Install smoke detector tube
8. Install condensate line trap and piping
9. Make electrical connections
10. Install other accessories

PAD-MOUNTED INSTALLATION

1. Prepare pad and unit supports
2. Rig and place unit
3. Remove duct covers and top skid
4. Install return air smoke detector sensor tube
5. Install field-fabricated ductwork at unit duct openings
6. Install outside air hood
7. Install condensate line trap and piping
8. Make electrical connections
9. Install other accessories

FRAME-MOUNTED INSTALLATION

Frame-mounted applications generally follow the sequence for a curb installation. Adapt as required to suit specific installation plan.

Step 3 — Inspect Unit

Inspect unit for transportation damage. File any claim with transportation agency.

Confirm before installation of unit that voltage, amperage and circuit protection requirements listed on unit data plate agree with power supply provided.

On units with hinged panel option, check to be sure all latches are tight and in closed position.

Locate the carton containing the outside air hood parts; see Fig. 17 and 24. Do not remove carton until unit has been rigged and located in final position.

Step 4 — Provide Unit Support

ROOF CURB MOUNT

Accessory roof curb details and dimensions are shown in Fig. 19-21. Assemble and install accessory roof curb in accordance with instructions shipped with the curb.

NOTE: The gasketing of the unit to the roof curb is critical for a watertight seal. Install gasket supplied with the roof curb as shown in Fig. 19-21. Improperly applied gasket can also result in air leaks and poor unit performance.

Curb should be level. This is necessary for unit drain to function properly. Unit leveling tolerances are shown in Fig. 18. Refer to Accessory Roof Curb Installation Instructions for additional information as required.

Table 2 — Operating Weights

| 50HC** | UNITS LB (KG) | | | |
|-----------------------------|---------------|------------|-------------|-------------|
| | 17 | 20 | 24 | 28 |
| COMPONENT | | | | |
| Base Unit | 1892 (858) | 2102 (954) | 2247 (1019) | 2292 (1040) |
| Economizer | 246 (112) | 246 (112) | 246 (112) | 246 (112) |
| Powered Outlet | 35 (16) | 35 (16) | 35 (16) | 35 (16) |
| Humidi-MiZer® System | 110 (50) | 120 (54) | 120 (54) | 120 (54) |
| Curb | | | | |
| 14-in. (356 mm) | 240 (109) | 255 (116) | 255 (116) | 273 (124) |
| 24-in. (610 mm) | 340 (154) | 355 (161) | 355 (161) | 355 (161) |

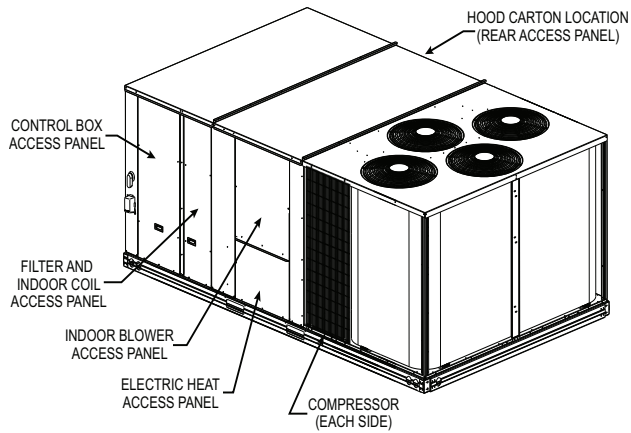
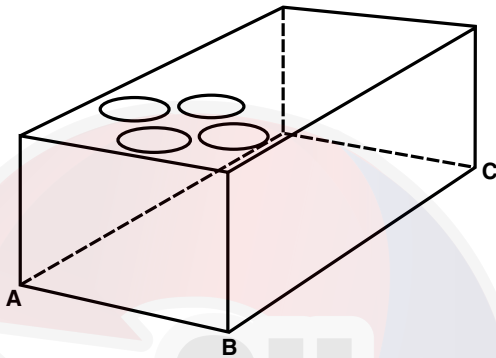

Fig. 17 — Typical Access Panel and Compressor Locations



| MAXIMUM ALLOWABLE DIFFERENCE IN. (MM) | | |
|---------------------------------------|-----------|-----------|
| A-B | B-C | A-C |
| 0.25" (6) | 0.5" (12) | 0.5" (12) |

Fig. 18 — Unit Leveling Tolerances

Install insulation, cant strips, roofing felt, and counter flashing as shown. *Ductwork must be attached to curb and not to the unit. Thru-the-base power connection must be installed before the unit is set on the roof curb.*

If electric and control wiring is to be routed through the basepan, remove knockouts in basepan located in control box area of access panel; see Fig. 2-16 for basepan knockout locations for location. Attach the service connections to the basepan.

SLAB MOUNT (HORIZONTAL UNITS ONLY)

Provide a level concrete slab that extends a minimum of 6-in. (150 mm) beyond unit cabinet. Install a gravel apron in front of condenser coil air inlet to prevent grass and foliage from obstructing airflow.

NOTE: Horizontal units may be installed on a roof curb if required.

ALTERNATE UNIT SUPPORT (IN LIEU OF CURB OR SLAB MOUNT)

A non-combustible sleeper rail can be used in the unit curb support area. If sleeper rails cannot be used, support the long sides of the unit with a minimum of 3 equally spaced 4-in. x 4-in. (102 mm x 102 mm) pads on each side. Locate pads so that they support the rails. Make sure to avoid the fork openings.

| UNIT SIZE | "A" | ROOF CURB ACCESSORY |
|-----------|--------------------------------|----------------------------------|
| 17 | 1'-2" [356.0] 2'-0" [610.0] | CRRFCURB045A00 CRRFCURB046A00 |

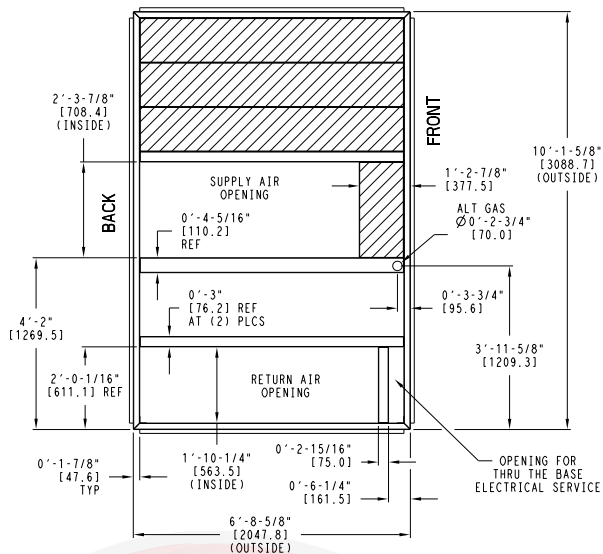

NOTES:

- 1 ROOF CURB ACCESSORY IS SHIPPED UNASSEMBLED.
- 2 DIMENSIONS IN () ARE IN MILLIMETERS.
- 3 ROOF CURB GALVANIZED STEEL.
- 4 ATTACH DUCTWORK TO CURB (FLANGES ON DUCT REST ON CURB)
- 5 SERVICE CLEARANCE 4 FT ON EACH SIDE

➔ DIRECTION OF AIR FLOW

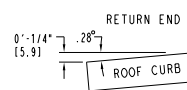
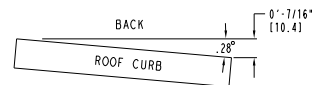

MAX CURB LEVELING TOLERANCES

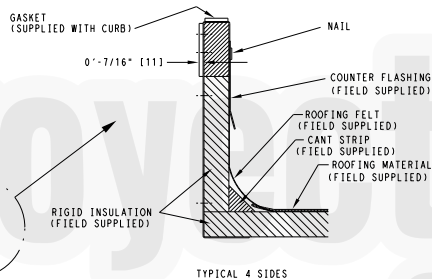
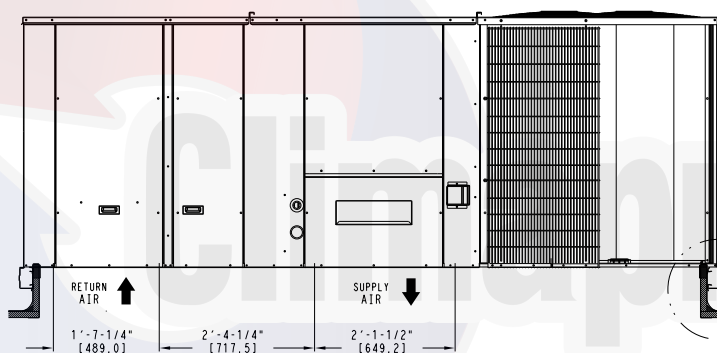

TYPICAL 4 SIDES

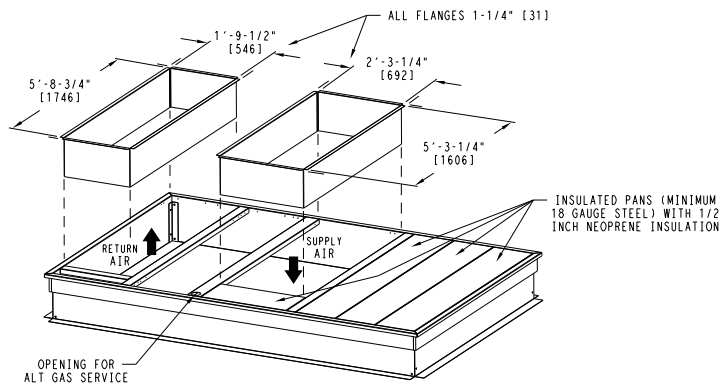
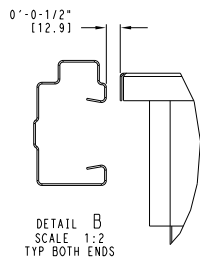
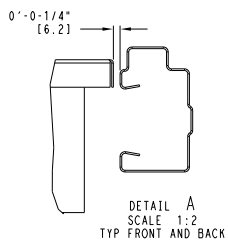
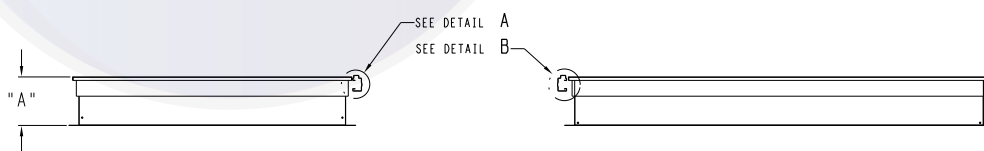
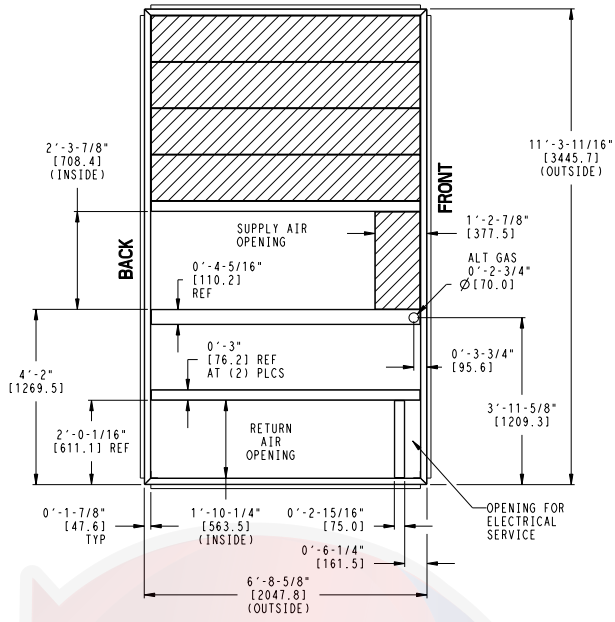

Fig. 19 — Roof Curb Details — 17 Size Unit

| UNIT SIZE | "A" | ROOF CURB ACCESSORY |
|-----------|---------------|---------------------|
| 20, 24 | 1'-2" [356.0] | CRRFCURB047A00 |
| | 2'-0" [610.0] | CRRFCURB048A00 |



NOTES:

- 1 ROOF CURB ACCESSORY IS SHIPPED UNASSEMBLED.
- 2 DIMENSIONS IN () ARE IN MILLIMETERS.
- 3 ROOF CURB GALVANIZED STEEL.
- 4 ATTACH DUCTWORK TO CURB (FLANGES ON DUCT REST ON CURB)
- 5 SERVICE CLEARANCE 4 FT ON EACH SIDE

➔ DIRECTION OF AIR FLOW

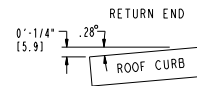
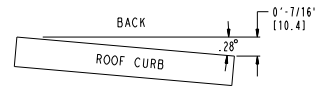

MAX CURB LEVELING TOLERANCES

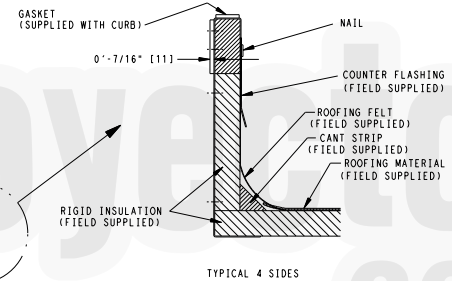
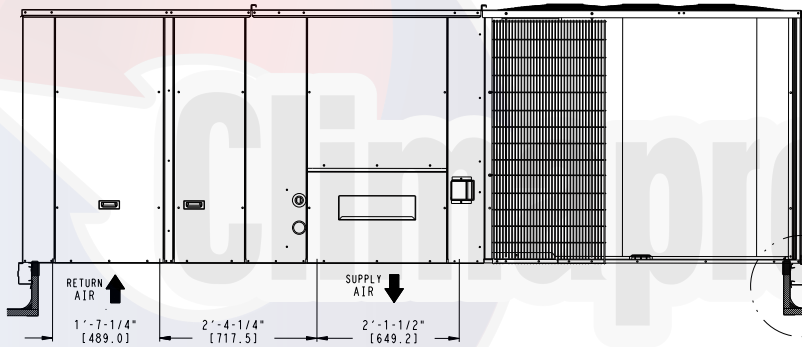

TYPICAL 4 SIDES

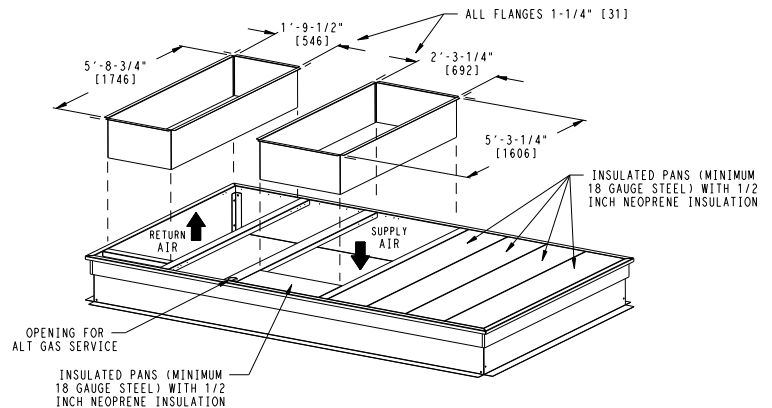
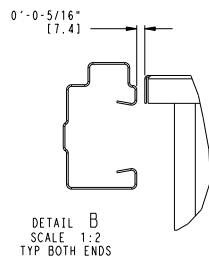
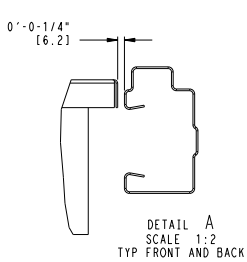
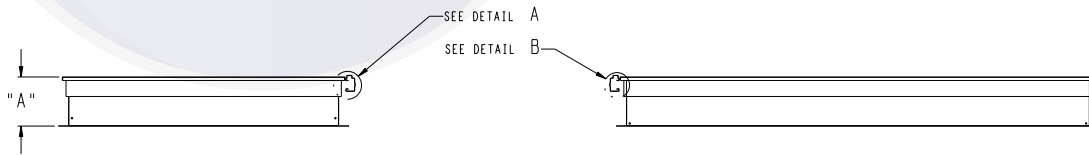
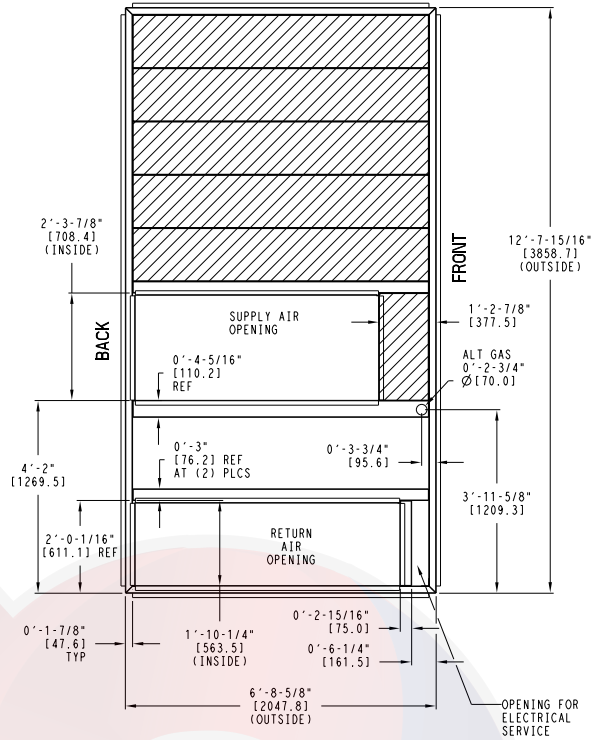

Fig. 20 — Roof Curb Details — 20 and 24 Size Units

| UNIT SIZE | "A" | ROOF CURB ACCESSORY |
|-----------|---------------|---------------------|
| 28 | 1'-2" [356.0] | CRRFCURB049A00 |
| | 2'-0" [610.0] | CRRFCURB050A00 |



- NOTES:
- 1 ROOF CURB ACCESSORY IS SHIPPED UNASSEMBLED.
 - 2 BOLT HEADS TO BE ON INSIDE OF FLANGE. CLEARANCE IS (11) 0-0-7/16" TYP ALL CORNERS.
 - 3 DIMENSIONS IN [] ARE IN MILLIMETERS.
 - 4 ROOF CURB GALVANIZED STEEL.
 - 5 ATTACH DUCTWORK TO CURB (FLANGES ON DUCT REST ON CURB)
 - 6 SERVICE CLEARANCE 4 FT ON EACH SIDE
 - 7 GAS SERVICE PLATE IS PART OF A SEPARATELY SHIPPED ACCESSORY PACKAGE.
 - 8 GAS SERVICE PLATE CAN BE USED WITH EITHER ACCESSORY ROOFCURB.

➔ DIRECTION OF AIR FLOW

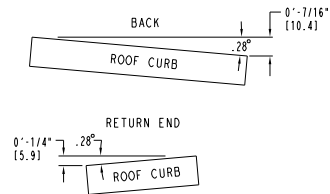

MAX CURB LEVELING TOLERANCES

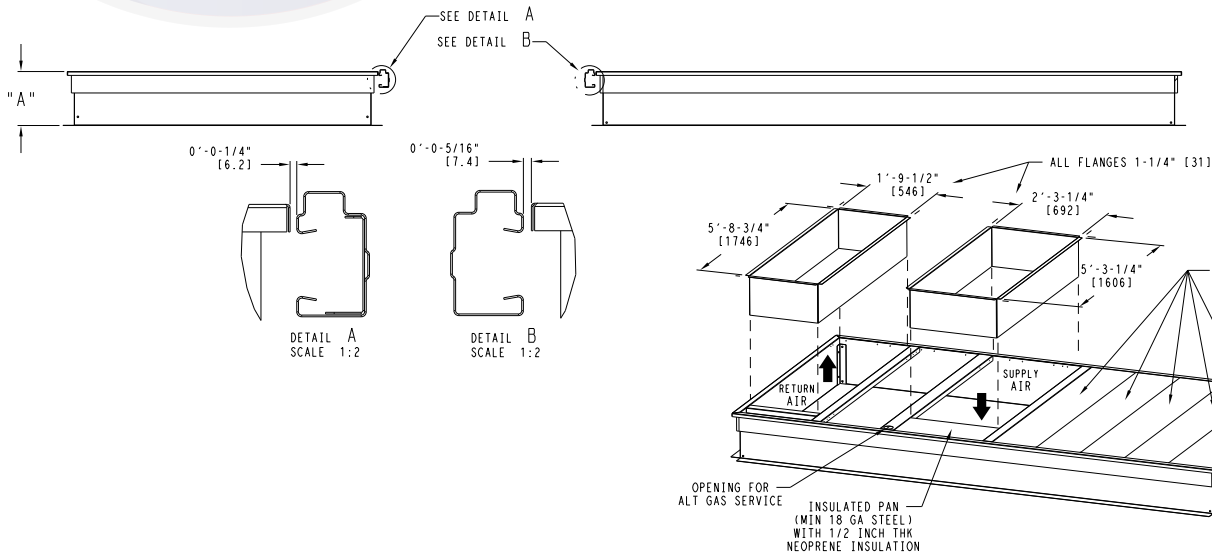
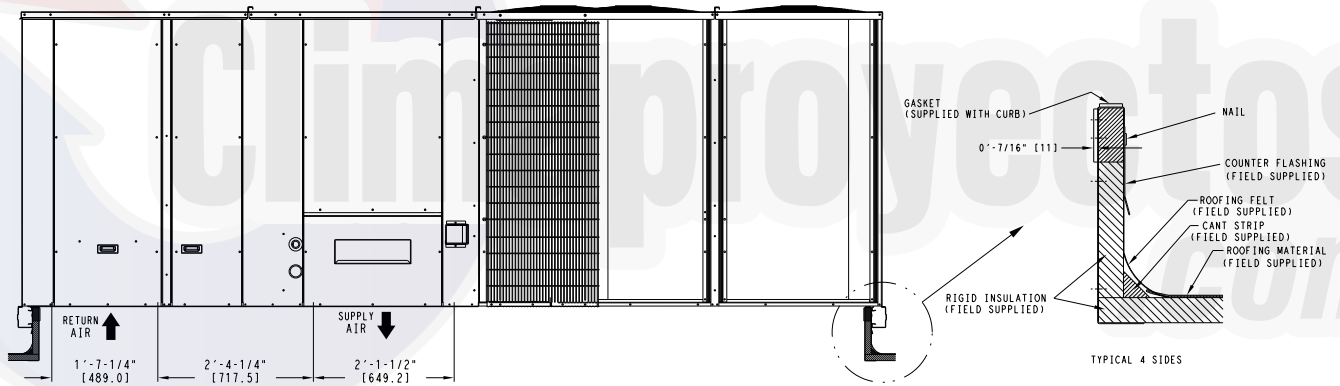

Fig. 21 — Roof Curb Details — 28 Size Unit

Step 5 — Field Fabricate Ductwork

Cabinet return-air static pressure (a negative condition) shall not exceed 0.5 in. wg (87 Pa) with economizer or without economizer.

For vertical ducted applications, secure all ducts to roof curb and building structure. *Do not connect ductwork to unit.*

Fabricate supply ductwork so that the cross sectional dimensions are equal to or greater than the unit supply duct opening dimensions for the first 18-in. (458 mm) of duct length from the unit basepan.

Insulate and weatherproof all external ductwork, joints, and roof openings with counter flashing and mastic in accordance with applicable codes.

Ducts passing through unconditioned spaces must be insulated and covered with a vapor barrier.

If a plenum return is used on a vertical unit, the return should be ducted through the roof deck to comply with applicable fire codes.

⚠ CAUTION

PROPERTY DAMAGE HAZARD

Failure to follow this caution may result in damage to roofing materials.

Membrane roofs can be cut by sharp sheet metal edges. Be careful when placing any sheet metal parts on such roof.

For units with optional or accessory electric heaters: minimum clearance is not required around ductwork.

⚠ WARNING

PERSONAL INJURY HAZARD

Failure to follow this warning could cause personal injury.

For vertical supply and return units, tools or parts could drop into ductwork and cause an injury. Install a 90 degree turn in the return ductwork between the unit and the conditioned space. If a 90 degree elbow cannot be installed, then a grille of sufficient strength and density should be installed to prevent objects from falling into the conditioned space. Due to electric heater, supply duct will require 90 degree elbow.

Step 6 — Rig and Place Unit

Keep unit upright and do not drop. Spreader bars are not required if top crating is left on unit. Rollers may be used to move unit across a roof. Level by using unit frame as a reference. See Table 2 (on page 19) and Fig. 22 for additional information.

Lifting holes are provided in base rails as shown in Fig. 19-21. Refer to rigging instructions on unit.

⚠ CAUTION

UNIT DAMAGE HAZARD

Failure to follow this caution may result in equipment damage.

All panels must be in place when rigging. Unit is not designed for handling by fork truck when packaging is removed.

If using top crate as spreader bar, once unit is set, carefully lower wooden crate off building roof top to ground. Ensure that no people or obstructions are below prior to lowering the crate.

Before setting the unit onto the curb, recheck gasketing on curb.

POSITIONING ON CURB

Position unit on roof curb so that the following clearances are maintained: 1/4-in. (6 mm) clearance between the roof curb and the base rail inside the right and left, 1/2-in. (12 mm) clearance between the roof curb and the base rail inside the front and back. This will result in the distance between the roof curb and the base rail inside on the condenser end of the unit being approximately equal to Details A and B in Fig. 19-21.

Do not attempt to slide unit on curb after unit is set. Doing so will result in damage to the roof curb seal.

Although unit is weatherproof, guard against water from higher level runoff and overhangs.

After unit is in position, remove rigging skids and shipping materials.

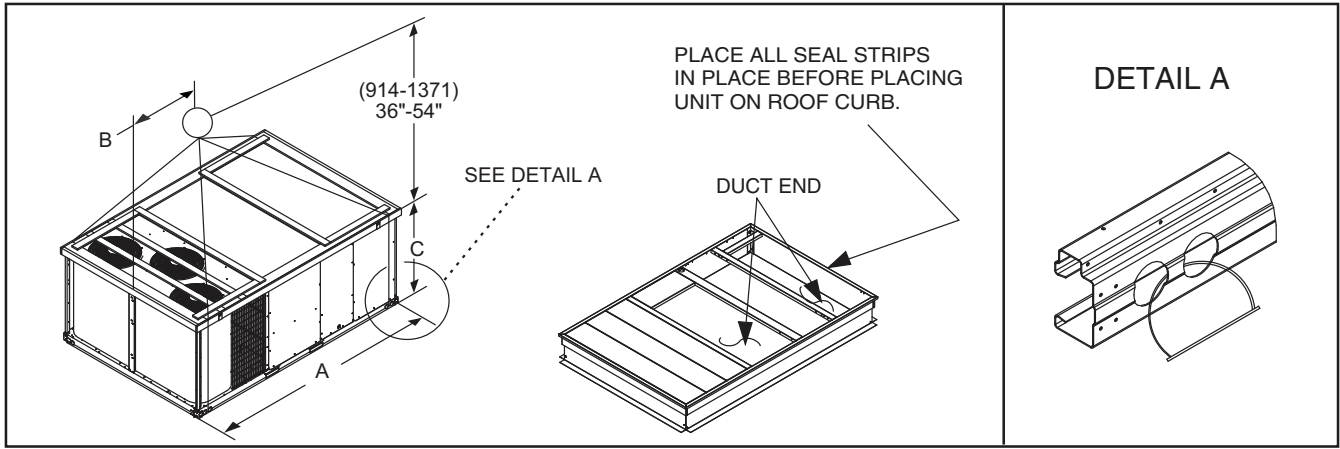

| UNIT | MAX WEIGHT | | DIMENSIONS | | | | | |
|----------|------------|------|------------|------|------|------|------|------|
| | lb | kg | A | | B | | C | |
| | | | in. | mm | in. | mm | in. | mm |
| 50HC**17 | 2212 | 1003 | 127.8 | 3249 | 58.7 | 1491 | 52.3 | 1328 |
| 50HC**20 | 2422 | 1099 | 141.5 | 3595 | 71.5 | 1816 | 52.3 | 1328 |
| 50HC**24 | 2572 | 1167 | 141.5 | 3595 | 71.5 | 1816 | 60.3 | 1532 |
| 50HC**28 | 2621 | 1189 | 157.8 | 4007 | 80.3 | 2040 | 60.3 | 1532 |

NOTES:

1. Dimensions in () are in millimeters.
2. Hook rigging shackles through holes in base rail, as shown in detail "A." Holes in base rails are centered around the unit center of gravity. Use wooden top to prevent rigging straps from damaging unit.

Fig. 22 — Rigging Details

Step 7 — Horizontal Duct Connection

Refer to Fig. 3, 8, and 13 for locations and sizes of the horizontal duct connections. Note that there are two different return air duct connection locations – one for unit without an economizer (on back side of unit) and a different one for unit equipped with an economizer (on left end, under the economizer hood). The supply air duct connection is on the back side. See Fig. 23 for top view depicting typical horizontal duct arrangements.

Field-supplied (3/4-in.) flanges should be attached to horizontal duct openings (see Fig. 23) and all ductwork should be secured to the flanges. Insulate and weatherproof all external ductwork, joints, and roof or building openings with counter flashing and mastic in accordance with applicable codes.

NOTE: 50HC size 17 to 28 units are factory assembled as either dedicated horizontal or vertical units. These units cannot be field converted.

Step 8 — Install Outside Air Hood — Factory Option

The outside air hood for factory-option economizer and two-position damper is shipped in knock-down form and requires field assembly. The panel for the hood top is shipped on the end of the unit (see Fig. 24). The remaining parts for the hood assembly (including side panels, filters and tracks) are shipped in a carton that is secured to the rear of the blower assembly. Access the carton location through rear panel (see Fig. 25).

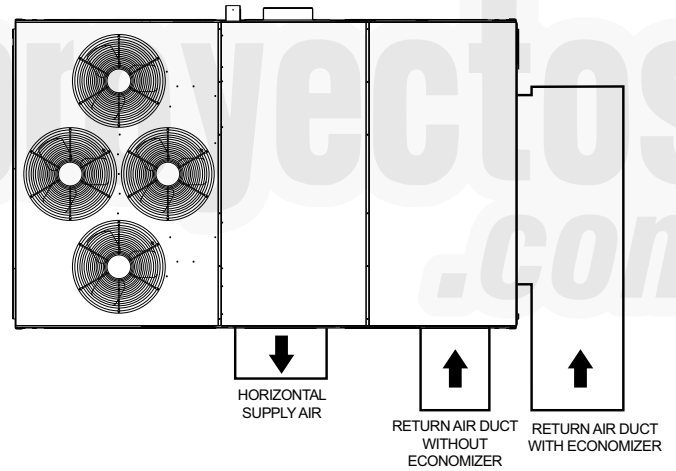

| | SUPPLY | RETURN WITHOUT ECONOMIZER | RETURN WITH ECONOMIZER |
|-------------------|--------------------------------------|---------------------------------------|---------------------------------------|
| Location | Back | Back | Left End |
| Height - in. (mm) | 15 ⁷ / ₈ (402) | 49 ³ / ₈ (1253) | 18 ³ / ₈ (467) |
| Width - in. (mm) | 29 ³ / ₄ (756) | 23 ³ / ₈ (593) | 61 ⁵ / ₈ (1564) |

Fig. 23 — Horizontal Duct Opening Dimensions

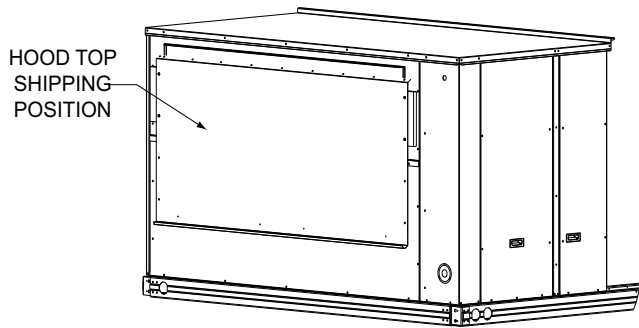

Fig. 24 — Hood Top — Shipping Position

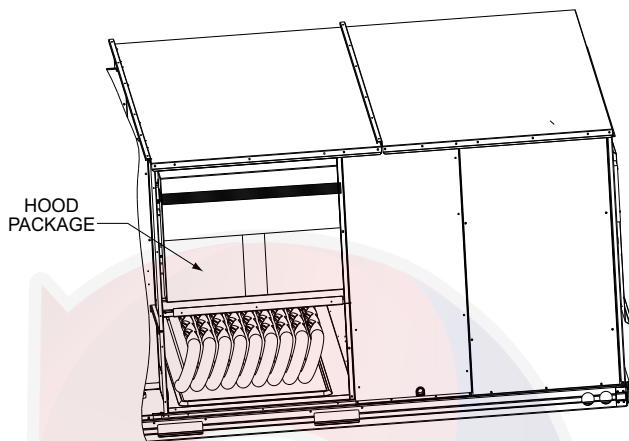

Fig. 25 — Hood Package — Shipping Location

To remove the hood parts package:

1. Remove the back blower access panel.
2. Locate and cut the strap, being careful to not damage any wiring.
3. Carefully lift the hood package carton through the back blower access opening.

To assemble the outside air hood (see Fig. 26 for hood component locations):

1. Remove hood top panel from shipping position on unit end.
2. Install filter supports (Item #1) to the upper end panel using the screws provided.
3. Install each deflector (Item #8) on to each filter support (Item #1) using the screws provided.
4. Apply seal strip to mating flanges on side plates of hood (Items #4 and #5).
5. Secure side panels (Items #4 and #5) to upper panel using the screws provided.
6. Apply seal strip to mating flange of the hood (see Fig. 26).
7. Secure hood top (Item #3) to upper panel using the screws provided. (On 44-in. chassis, remove the screws from across top cover of unit. The rear flange of hood top will slide behind unit top over flange.)
8. Secure side retainers (Item #6) to side panels (Items #4 and #5) using the screws provided, screwing from outside of the hood.
9. Secure each central retainer (Item #2) to the hood top (Item #3). Then align central retainers to holes located on filter support (Item #1), so central retainer is perpendicular to hood and each filter support. Secure using screws provided.
10. Apply seal strip to top diverters (Item #7).
11. Secure top diverters (Item #7) to hood top (Item #3).

12. Install outdoor air screens by sliding them into each of the four spaces created by the hood, filter support and central retainers. To do so, first insert the air screens into pocket created at the end of hood (Item #3), then fully put the air screen into place, and then slide them back into pocket created in the filter support (Item #1). Repeat this for each air screen (see Fig. 27). See Fig. 28 for completed hood assembly.

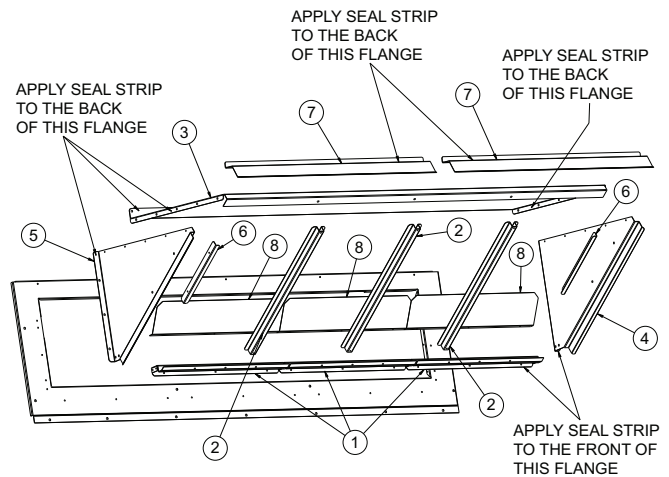

| ITEM # | DESCRIPTION | QTY |
|--------|------------------|-----|
| 1 | Filter Supports | 3 |
| 2 | Central Retainer | 3 |
| 3 | Hood Top | 1 |
| 4 | Left Hood Side | 1 |
| 5 | Right Hood Side | 1 |
| 6 | Side Retainer | 2 |
| 7 | Top Diverters | 2 |
| 8 | Deflector | 3 |

Fig. 26 — Hood Part Identification and Seal Strip Application Areas

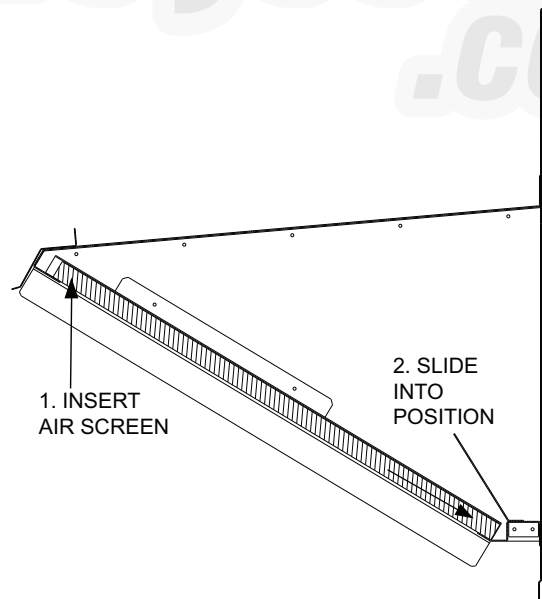

Fig. 27 — Outdoor Air Screen Installation

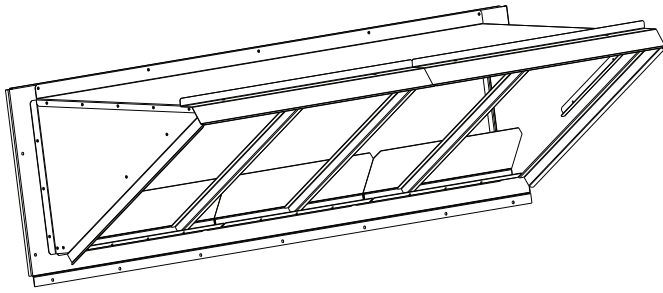

Fig. 28 — Completed Hood Assembly

Step 9 — Assemble Barometric Hood

The barometric hood can be assembled in vertical or horizontal configuration. Figure 29 illustrates the barometric hood parts.

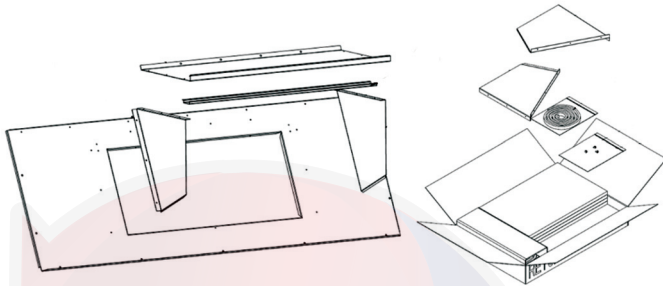

Fig. 29 — Barometric Hood Parts

BAROMETRIC HOOD (VERTICAL CONFIGURATION)

1. Remove the hood top panel from its shipping position on the unit end (see Fig. 30).

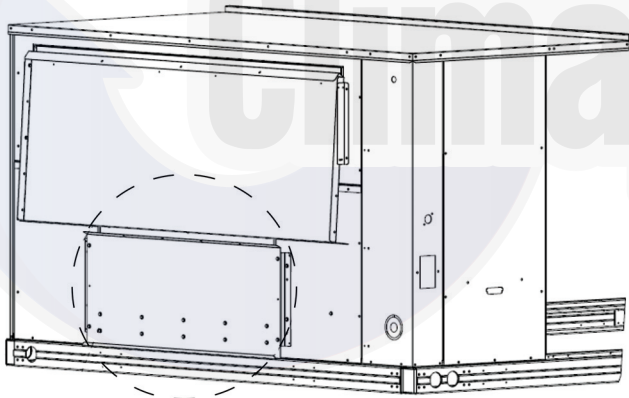

Fig. 30 — Shipping Location, Vertical Units

2. Remove the side panels located in the hood parts box (see Fig. 31).

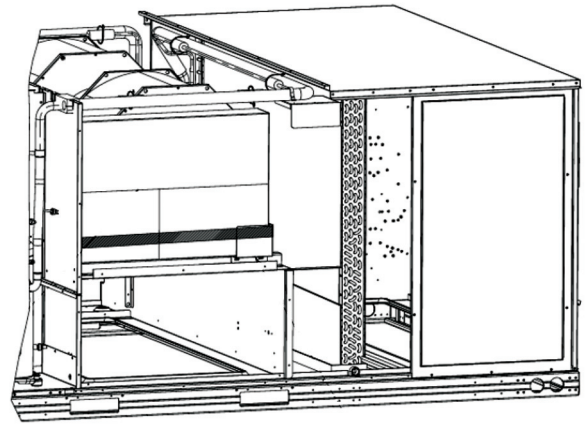

Fig. 31 — Barometric Hood Box Parts Location

3. Install parts as shown in the following exploded view (Fig. 32) using the seal strip and screws provided in the parts box.

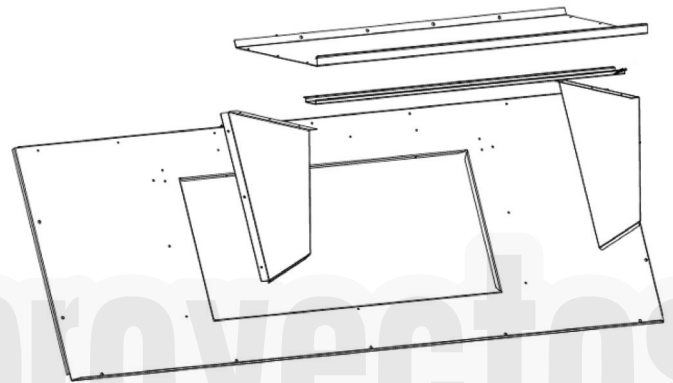

Fig. 32 — Barometric Hood Exploded View

Figure 33 illustrates the installed barometric hood parts.

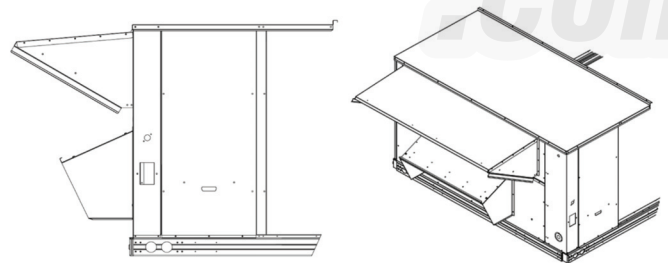

Fig. 33 — Installed Barometric Hood Side View and Isometric View

BAROMETRIC HOOD (HORIZONTAL CONFIGURATION)

For horizontal return and field installed economizer, install the economizer as follows:

1. Install the field provided horizontal ductwork onto the unit. Duct height must be at least 19 1/2 inches high, however the duct can be no taller than the top of the relief opening in the bottom panel, or airflow into the outside air hood will be restricted. See Fig. 34.

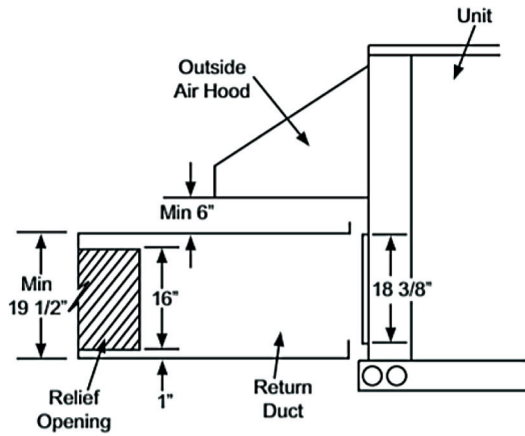

Fig. 34 — Relief Damper

2. Cut a 16 in. x 36 in. opening in the return duct for the relief damper (see Fig. 34).
3. On the field installed economizer (CRECOMZR0**A00), a birdscreen or hardware cloth is shipped attached to the bottom panel used for vertical applications.

NOTE: This panel is not used for horizontal return applications. Remove the screen from the provided panel and install it over the relief opening cut in return duct.

4. Using the blade brackets, install the relief damper onto the side of the return duct (see Fig. 35). The two brackets and relief damper are provided with the economizer.

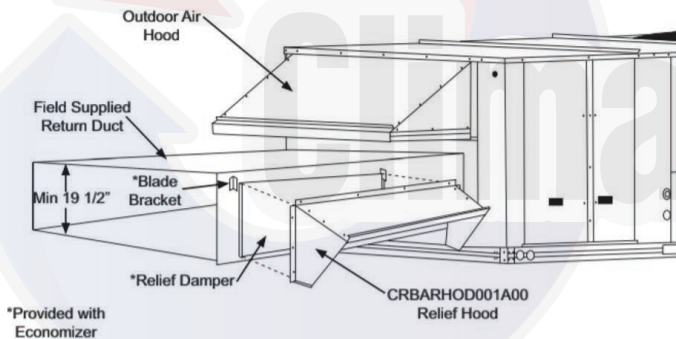

Fig. 35 — Installing CRBARHOD001A00 Over Relief Damper

5. Using the provided hardware, screw the CRBARHOD001A00 hood sides and top together (see Fig. 36).

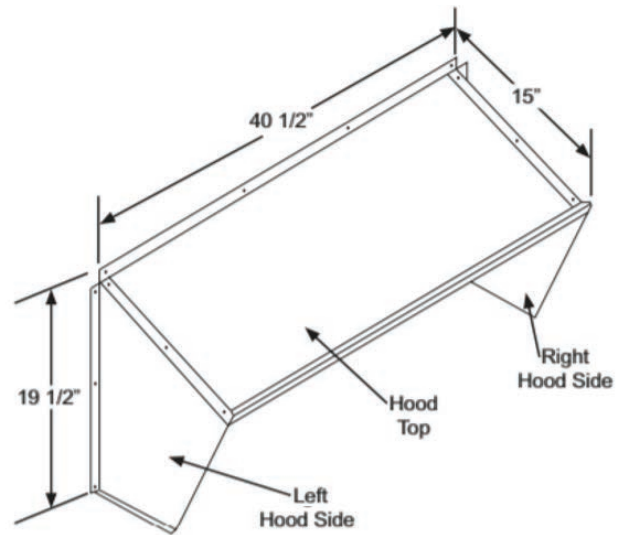

Fig. 36 — CRBARHOD001A00 Hood Sides and Top

Caulk the backside of the mating flanges to ensure a watertight seal. Install the CRBARHOD001A00 over the relief damper and screw to the return duct, as illustrated in Fig. 35.

Step 10 — Install External Condensate Trap and Line

The unit has one 3/4-in. condensate drain connection on the end of the condensate pan (see Fig. 37). See Fig. 4, 9, and 14 for the location of the condensate drain connection.

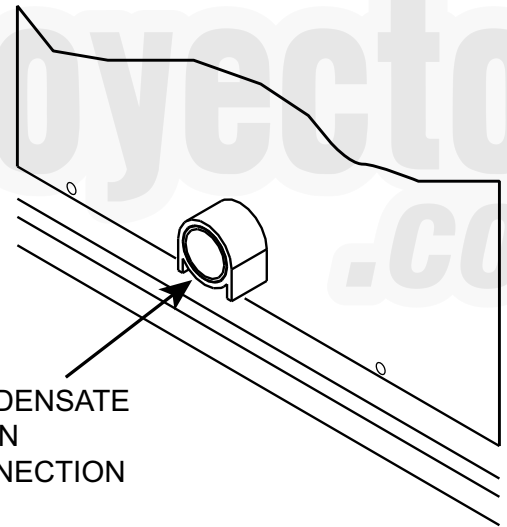
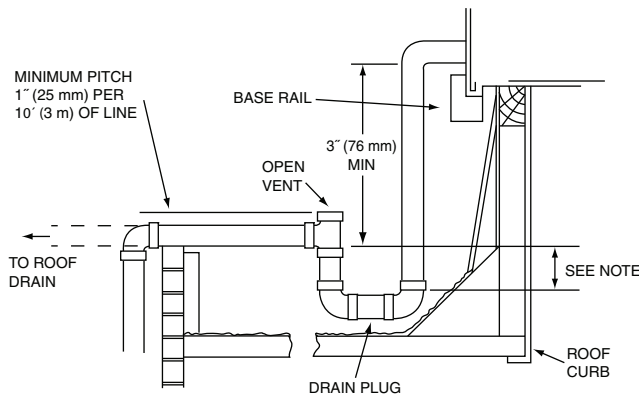

Fig. 37 — Condensate Drain Pan Connection

The piping for the condensate drain and external trap can be completed after the unit is in place. Hand tighten fittings to the drain pan fitting. Provide adequate support for the drain line. Failure to do so can result in damage to the drain pan. See Fig. 38.



NOTE: Trap should be deep enough to offset maximum unit static difference. A 4-in. (102 mm) trap is recommended.

Fig. 38 — Condensate Drain Piping Details

All units must have an external trap for condensate drainage. Install a trap at least 4-in. (102 mm) deep and protect against freeze-up. If drain line is installed downstream from the external trap, pitch the line away from the unit at 1-in. per 10 ft (25 mm in 3 m) of run. Do not use a pipe size smaller than the unit connection (3/4-in.).

Step 11 — Make Electrical Connections

⚠ WARNING

ELECTRIC SHOCK HAZARD

Failure to follow this warning could result in personal injury or death.

Unit cabinet must have an uninterrupted, unbroken electrical ground to minimize the possibility of personal injury if an electrical fault should occur. This ground may consist of electrical wire connected to unit ground lug in control compartment, or conduit approved for electrical ground when installed in accordance with NEC; ANSI/NFPA 70, latest edition (in Canada, Canadian Electrical Code CSA [Canadian Standards Association] C22.1), and local electrical codes.

NOTE: Field-supplied wiring shall conform with the limitations of minimum 63°F (3°C) rise.

FIELD POWER SUPPLY

If equipped with optional powered convenience outlet: the power source leads to the convenience outlet's transformer primary are not factory connected. Installer must connect these leads according to required operation of the convenience outlet. If an always-energized convenience outlet operation is desired, connect the source leads to the line side of the unit-mounted disconnect. (Check with local codes to ensure this method is acceptable in your area.) If a de-energize via unit disconnect switch operation of the convenience outlet is desired, connect the source leads to the load side of the unit disconnect. On a unit without a unit-mounted disconnect or HACR, connect the source leads to the terminal block with unit field power leads. See Fig. 39.

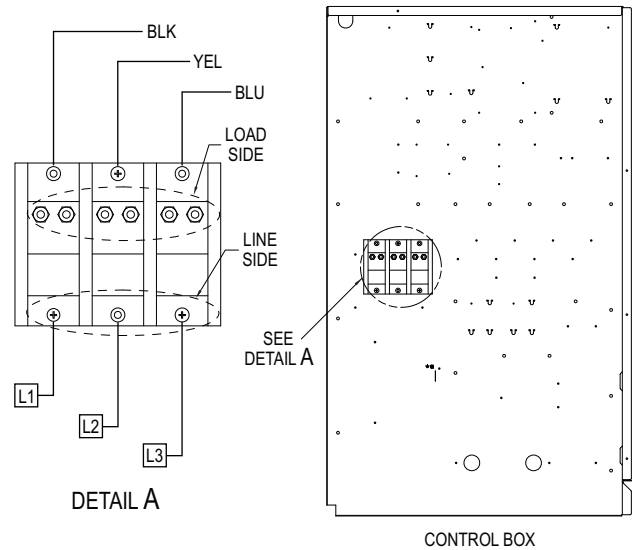

Fig. 39 — Location of TB1

Field power wires are connected to the unit at line-side pressure lugs on the terminal block (see wiring diagram label for control box component arrangement) or at factory-installed option non-fused disconnect switch or HACR breaker. Use copper conductors only. See Fig. 40.

NOTE: Make field power connections directly to line connection pressure lugs only.

⚠ WARNING

FIRE HAZARD

Failure to follow this warning could result in personal injury, death, or property damage.

Do not connect aluminum wire between disconnect switch and unit. Use only copper wire.

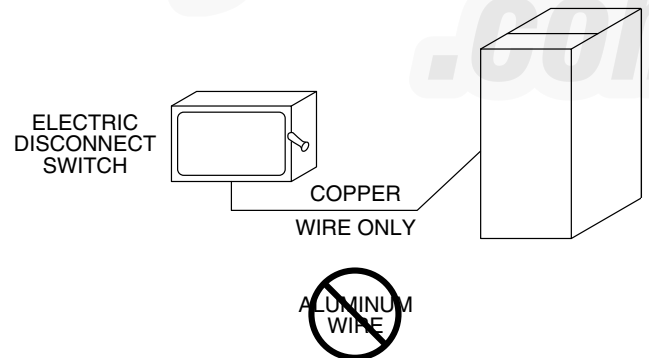

Fig. 40 — Disconnect Switch and Unit

UNITS WITHOUT FACTORY-INSTALLED NON-FUSED DISCONNECT OR HACR

When installing units, provide a disconnect switch of adequate size per NEC (National Electrical Code). Disconnect sizing data is provided on the unit informative plate. Locate on unit cabinet or within sight of the unit per national or local codes. Do not cover unit informative plate if mounting the disconnect on the unit cabinet.

UNITS WITH FACTORY-INSTALLED NON-FUSED DISCONNECT OR HACR

The factory-installed option non-fused disconnect switch (NFD) or HACR is located in the main control box. The manual switch handle and shaft are shipped in the control box and must be mounted on the corner post adjacent to the control box (see Fig. 41 or 42). Note that the tape covering the hole for the shaft in the corner post must be removed prior to handle and shaft installation.

To field install the NFD shaft and handle:

1. Open the control box panel.
2. Make sure the NFD shipped from the factory is at OFF position (the arrow on the black handle knob or on the silver metal collar is at OFF).
3. Insert the shaft with the cross pin on the top of the shaft in the horizontal position.
4. Measure the tip of the shaft to the outside surface of the corner post to be 0.88 inches.
5. Tighten the locking screw to secure the shaft to the NFD.
6. Turn the handle to the OFF position with red arrow pointing at OFF.
7. Install the handle on to the corner post vertically with the red arrow pointing up.
8. Secure the handle to the corner post with (2) screws and lock washers supplied.

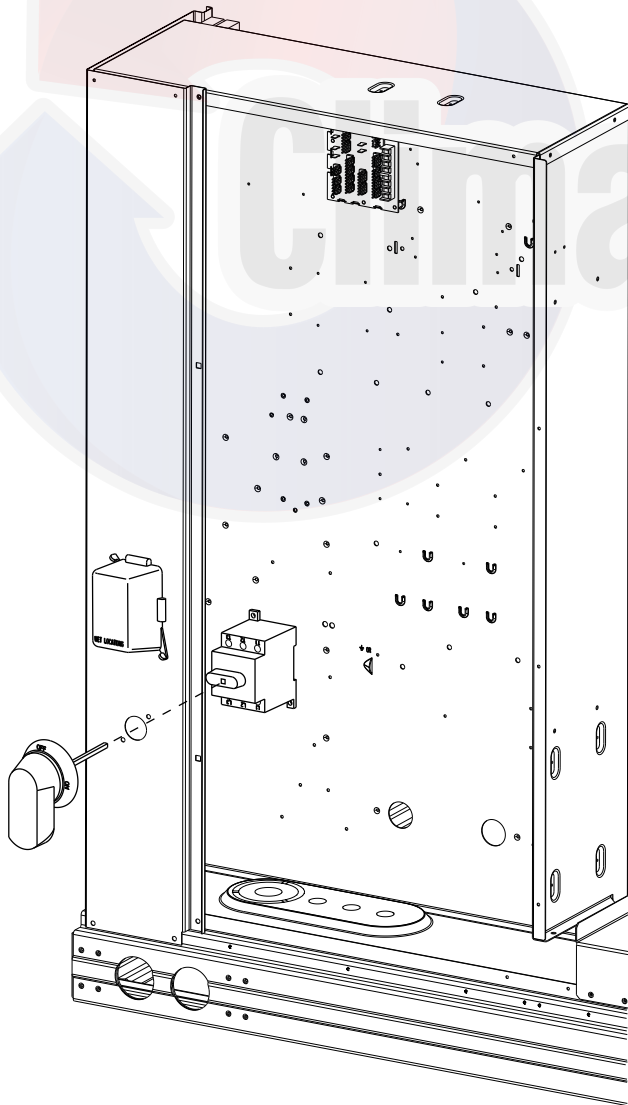

Fig. 41 — Handle and Shaft Assembly for NFD

To field install the HACR shaft and handle:

1. Open the control box panel.
2. Make sure the HACR shipped from the factory is at OFF position (the white arrow pointing at OFF).
3. Insert the shaft all the way with the cross pin on the top of the shaft in the horizontal position.
4. Measure the tip of the shaft to the outside surface of the corner post to be 0.88 inches.
5. Tighten the locking screw to secure the shaft to the HACR.
6. Turn the handle to the OFF position with red arrow pointing at OFF.
7. Install the handle on to the corner post vertically with the red arrow pointing up.
8. Secure the handle to the corner post with (2) screws and lock washers supplied.

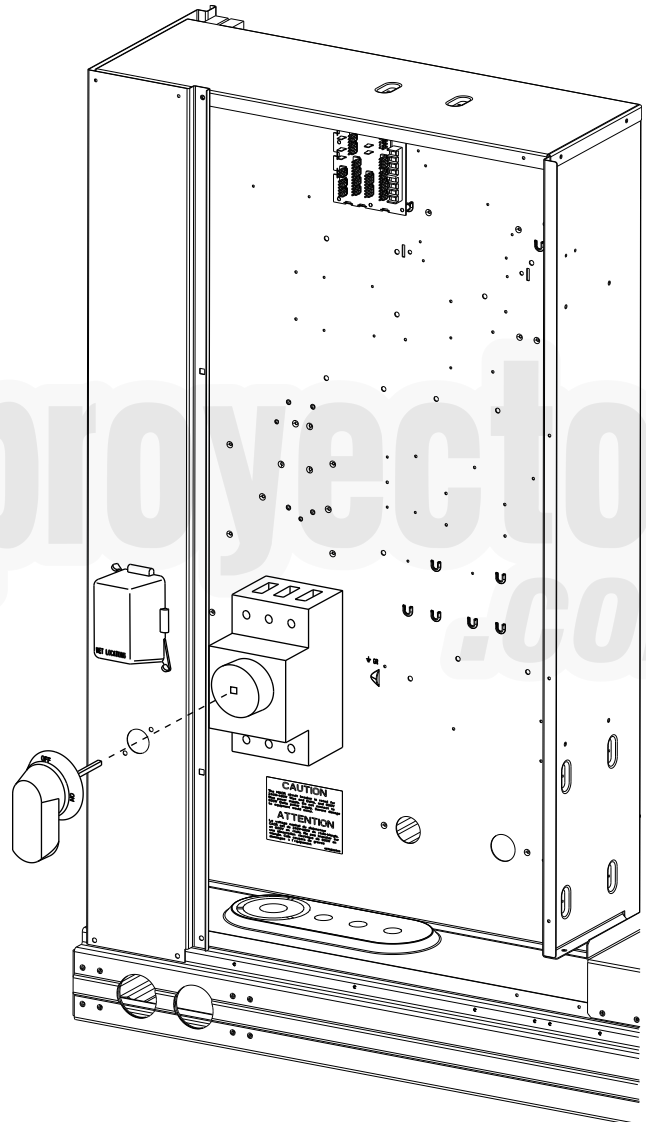

Fig. 42 — Handle and Shaft Assembly for HACR

ALL UNITS

All field wiring must comply with NEC and all local requirements.

Size wire based on MCA (Minimum Circuit Amps) on the unit informative plate. See Fig. 43 for power wiring connections to the unit power terminal blocks and equipment ground. Maximum wire size is 2/0 AWG per pole.

Provide a ground-fault and short-circuit over-current protection device (fuse or breaker) per NEC Article 440 (or local codes). Refer to unit informative data plate for MOCP (Maximum Over-current Protection) device size.

NOTE: Units ordered with factory installed HACR do not need an additional ground-fault and short-circuit over-current protection device unless required by local codes.

Voltage to compressor terminals during operation must be within voltage range indicated on unit nameplate. On 3-phase units, voltages between phases must be balanced within 2% and the current within 10%. Use the following formula to determine the percent of voltage imbalance.

$$\% \text{ Voltage Imbalance} = 100 \times \frac{\text{max voltage deviation from average voltage}}{\text{average voltage}}$$

Example: Supply voltage is 230-3-60



AB = 224 v
BC = 231 v
AC = 226 v

$$\text{Average Voltage} = \frac{(224 + 231 + 226)}{3} = \frac{681}{3} = 227$$

Determine maximum deviation from average voltage.

(AB) 227-224 = 3 v
(BC) 231-227 = 4 v
(AC) 227-226 = 1 v
Maximum deviation is 4 v.

Determine percent of voltage imbalance.

$$\% \text{ Voltage Imbalance} = 100 \times \frac{4}{227} = 1.78\%$$

This amount of phase imbalance is satisfactory as it is below the maximum allowable 2%.

IMPORTANT: If the supply voltage phase imbalance is more than 2%, contact your local electric utility company immediately.

⚠ CAUTION

UNIT DAMAGE HAZARD

Failure to follow this caution may result in equipment damage. Operation on improper line voltage or excessive phase imbalance constitutes abuse and may cause damage to electrical components. Such operation would invalidate any applicable Carrier warranty.

UNITS WITHOUT DISCONNECT OR HACR OPTION

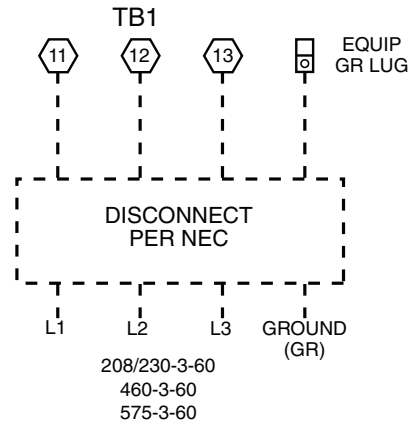

UNITS WITH DISCONNECT OR HACR OPTION

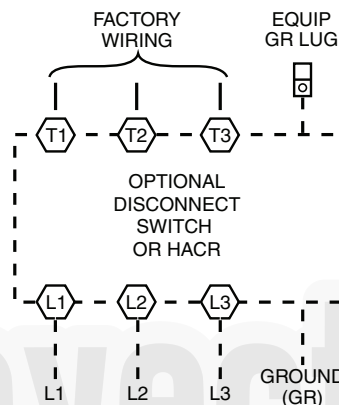

Fig. 43 — Power Wiring Connections

CONVENIENCE OUTLETS

⚠ WARNING

ELECTRICAL OPERATION HAZARD

Failure to follow this warning could result in personal injury or death.

Units with convenience outlet circuits may use multiple disconnects. Check convenience outlet for power status before opening unit for service. Locate its disconnect switch, if appropriate, and open it. Lock-out and tag-out this switch, if necessary.

Two types of convenience outlets are offered on 50HC models: non-powered and unit-powered. Both types provide a 125-volt GFCI (ground-fault circuit-interrupter) duplex receptacle rated at 15-A behind a hinged waterproof access cover, located on the panel beneath the control box. See Fig. 44.

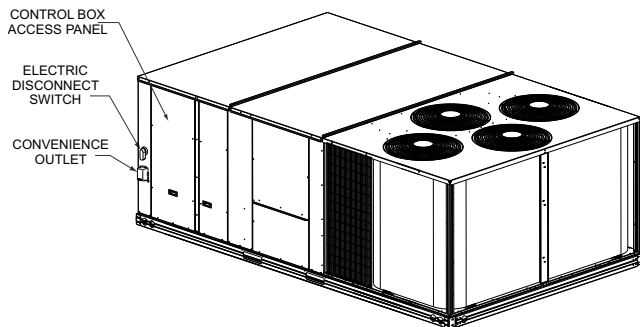

Fig. 44 — Convenience Outlet Location

Installing Weatherproof Cover

A weatherproof while-in-use cover for the factory-installed convenience outlets is now required by UL standards. This cover cannot be factory-mounted due its depth; it must be installed at unit installation. For shipment, the convenience outlet is covered with a blank cover plate.

The weatherproof cover kit is shipped in the unit's control box. The kit includes the hinged cover, a backing plate and gasket.

DISCONNECT ALL POWER TO UNIT AND CONVENIENCE OUTLET. LOCK-OUT AND TAG-OUT ALL POWER.

Remove the blank cover plate at the convenience outlet; discard the blank cover.

Loosen the two screws at the GFCI duplex outlet, until approximately 1/2-in. (13 mm) under screw heads are exposed. Press the gasket over the screw heads. Slip the backing plate over the screw heads at the keyhole slots and align with the gasket; tighten the two screws until snug (do not over-tighten).

Mount the weatherproof cover to the backing plate as shown in Fig. 45. Remove two slot fillers in the bottom of the cover to permit service tool cords to exit the cover. Check for full closing and latching.

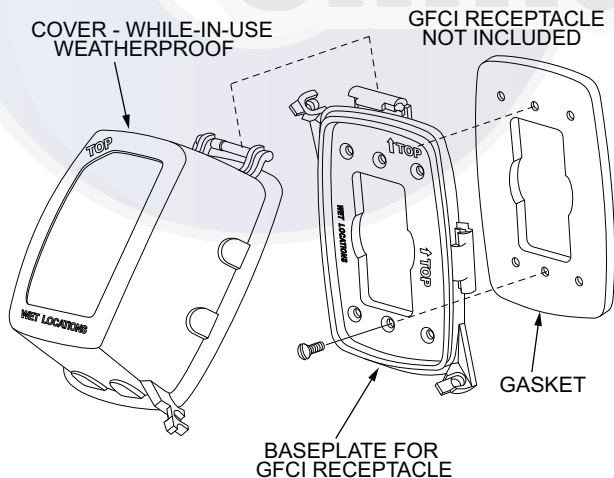

Fig. 45 — Weatherproof Cover Installation

Non-powered type

This type requires the field installation of a general-purpose 125-v 15-A circuit powered from a source elsewhere in the building. Observe national and local codes when selecting wire size and conduit requirements, fuse or breaker requirements and disconnect switch size and location. Route 125-v power supply conductors into the bottom of the utility box containing the duplex receptacle.

Unit-powered type

A unit-mounted transformer is factory-installed to stepdown the main power supply voltage to the unit to 115-v at the duplex receptacle. This option also includes a manual switch with fuse,

located in a utility box and mounted on a bracket behind the convenience outlet; access is through the unit's control box access panel. See Fig. 44.

The primary leads to the convenience outlet transformer are not factory-connected. If local codes permit, the transformer primary leads can be connected at the line-side terminals on the unit-mounted non-fused disconnect switch; this will provide service power to the unit when the unit disconnect switch is open. See Fig. 46. See Fig. 47 for convenience outlet utilization notice.

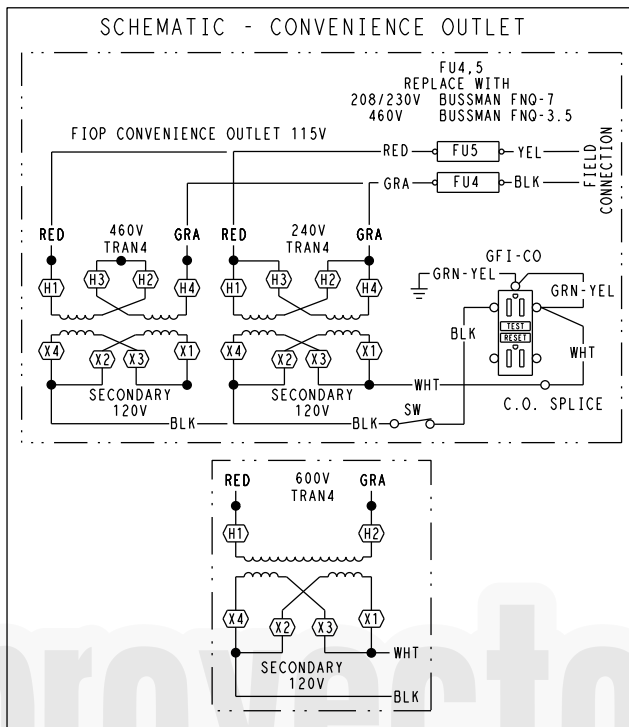

| UNIT VOLTAGE | CONNECT AS | PRIMARY CONNECTIONS | TRANSFORMER TERMINALS |
|--------------|------------|--|-----------------------|
| 208,230 | 240 | L1: RED + YEL L2: BLU + GRA | H1 + H3 H2 + H4 |
| 460 | 480 | L1: RED L2: Splice BLU + YEL L2: GRA | H1 H2 + H3 H4 |
| 575 | 600 | L1: RED L2: GRA | H1 H2 |

Fig. 46 — Powered Convenience Outlet Wiring

NOTICE/AVIS

Convenience Outlet Utilization

Maximum Intermittent Use 15 - Amps
Maximum Continuous Use 8 - Amps
Observe a 50% limit on the circuit
Loading above 8 - Amps

Utilisation de la prise utilitaire

Usage intermittent maximum 15 - Amps
Usage continu maximum 8 - Amps
Observez une limite de 50% sur le circuit
Chargement au-dessus de 8 - Amps

50HE501288 2.0

Fig. 47 — Convenience Utilization Notice

Test the GFCI receptacle by pressing the TEST button on the face of the receptacle to trip and open the receptacle. Check for proper grounding wires and power line phasing if the GFCI receptacle does not trip as required. Press the RESET button to clear the tripped condition.

Using unit-mounted convenience outlets

Units with unit-mounted convenience outlet circuits will often require that two disconnects be opened to de-energize all power to the unit. Treat all units as electrically energized until the convenience outlet power is also checked and de-energization is confirmed. Observe National Electrical Code Article 210, Branch Circuits, for use of convenience outlets.

HACR

The amp rating of the HACR factory-installed option is based on the size, voltage, indoor motor and other electrical options of the unit as shipped from the factory. If field-installed accessories are added or changed in the field (i.e., power exhaust), the HACR may no longer be of the proper amp rating and therefore will need to be removed from the unit. See unit nameplate and label on factory-installed HACR for the amp rating of the HACR that was shipped with the unit from the factory. See unit nameplates for the proper fuse, HACR or maximum over-current protection device required on the unit with field-installed accessories. See Fig. 48 for HACR caution label.

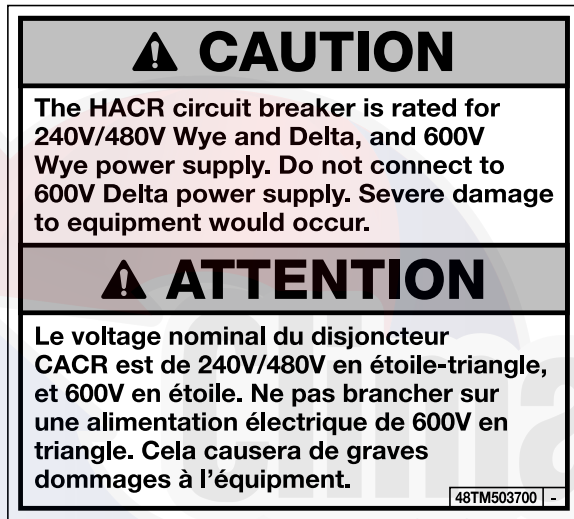

Fig. 48 — HACR Caution Label

FACTORY OPTION THRU-BASE CONNECTIONS

All units are equipped with the ability to bring utilities through the base.

The electrical entrance is located in the control box area and can be accessed through the control box access panel. An embossed area is provided with three knock outs. High voltage is brought through the multi knock out by removing the appropriate size for the size of the fitting required. A 7/8-in. knock out is provided for low voltage. An additional 7/8-in. knock out is provided for a 115-v line which is used when the unit is equipped with the non-unit powered convenience outlet option.

All required fittings are field supplied. Install fittings when access to both top and bottom of the base pan is available.

UNITS WITHOUT THRU-BASE CONNECTIONS

1. Install liquid tight conduit between disconnect and control box.
2. Pull correctly rated high voltage wires through the conduit.
3. Install power lines to terminal connections as shown in Fig. 43.

FIELD CONTROL WIRING

The 50HC unit requires an external temperature control device. This device can be a thermostat (field-supplied) or a Premier-Link™ controller (available as factory-installed option or as field-installed accessory, for use on a Carrier Comfort Network® or as a stand alone control) or the RTU Open controller for Building Management Systems using non-CCN protocols (RTU Open controller is available as a factory-installed option only).

THERMOSTAT

Select a Carrier-approved accessory thermostat. When electric heat is installed in the 50HC unit, the thermostat must be capable of energizing the G terminal (to energize the Indoor Fan Contactor) whenever there is a space call for heat (energizing the W1 terminal). The accessory thermostats listed on the unit price pages can provide this signal but they are not configured to enable this signal as shipped.

Install the accessory thermostat according to installation instructions included with the accessory.

Locate the thermostat accessory on a solid wall in the conditioned space to sense average temperature in accordance with the thermostat installation instructions.

If the thermostat contains a logic circuit requiring 24-v power, use a thermostat cable or equivalent single leads of different colors with minimum of seven leads. If the thermostat does not require a 24-v source (no "C" connection required), use a thermostat cable or equivalent with minimum of six leads. Check the thermostat installation instructions for additional features which might require additional conductors in the cable.

For wire runs up to 50 ft (15 m), use no. 18 AWG (American Wire Gage) insulated wire (35°C minimum). For 50 to 75 ft (15 to 23 m), use no. 16 AWG insulated wire (35°C minimum). For over 75 ft (23 m), use no. 14 AWG insulated wire (35°C minimum). All wire sizes larger than no. 18 AWG cannot be directly connected to the thermostat and will require a junction box and splice at the thermostat. See Fig. 49 for typical connections.

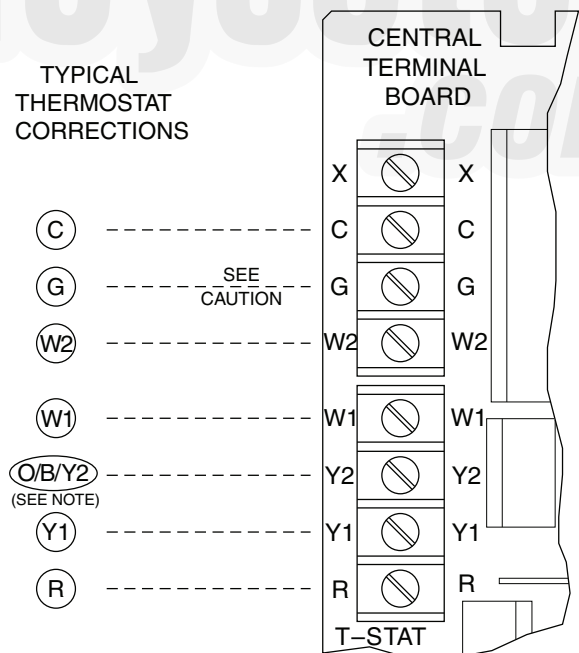

NOTE: Typical multi-function marking. Follow manufacturer's configuration instructions to select Y2.

--- Field Wiring

Fig. 49 — Typical Low-Voltage Control Connections

CAUTION

UNIT DAMAGE HAZARD

Failure to follow this caution may cause a short circuit.

Carefully check the connection of control conductor for indoor fan control at terminal G. Connecting the indoor fan lead to terminal C will cause a short circuit condition, which can cause component damage inside the unit or at the thermostat.

UNIT WITHOUT THRU-BASE CONNECTION KIT

Correctly rated low voltage wire can be routed through the rubber grommet located on the corner post adjacent to the control box access panel. Route wire through the grommet and then route the wire behind the corner post utilizing the factory provided wire ties secured to the control box. This will ensure separation of the field low voltage wire and the high voltage circuit. Route the low voltage wire to the central terminal board. See Fig. 50.

NOTE: If utilizing the through the base connections, route the low voltage wire through the wire ties to the central terminal board.

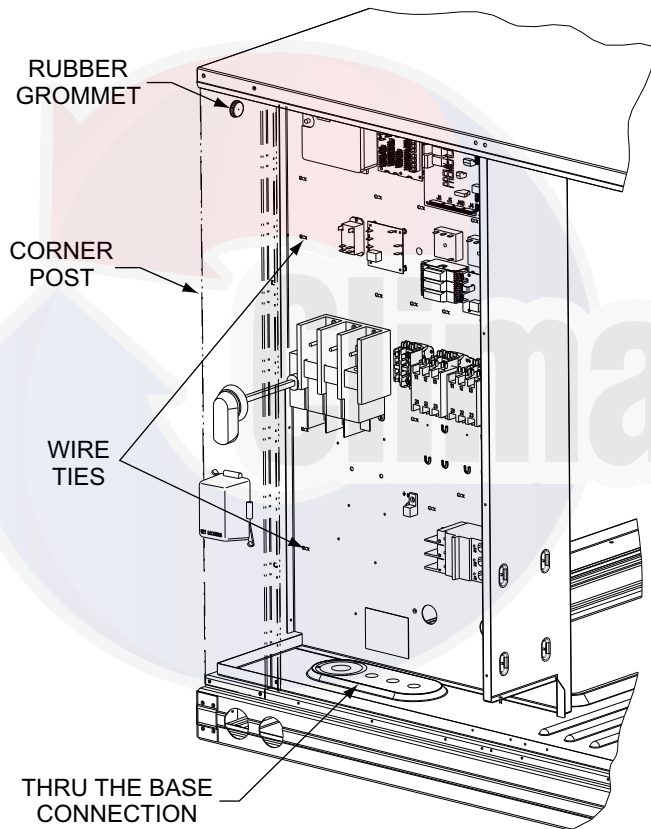

Fig. 50 — Field Control Wiring Raceway

HEAT ANTICIPATOR SETTINGS

Set heat anticipator settings at 0.14 amp for the first stage and 0.14 amp for second-stage heating.

TRANSFORMER CONNECTION FOR 208-V POWER SUPPLY

All units except 208/230-v units are factory wired for the voltage shown on the nameplate. *If the 208/230-v unit is to be connected to a 208-v power supply, the control transformer must be rewired by moving the black wire with the 1/4-in. female spade connector from the 230-v connection and moving it to the 208-v 1/4-in. male terminal on the primary side of the transformer.* Refer to unit label diagram for additional information.

Electric Heaters

The 50HC units may be equipped with field-installed electric heaters. The heaters are modular in design.

Heater modules are installed in the compartment below the indoor blower access panel. Access is through the electric heat access panel. Heater modules slide into the compartment on tracks along the bottom of the heater opening. See Fig. 51-53. Refer to the Electric Heater Kit Installation Instructions for complete details on field installed electric heat accessory.

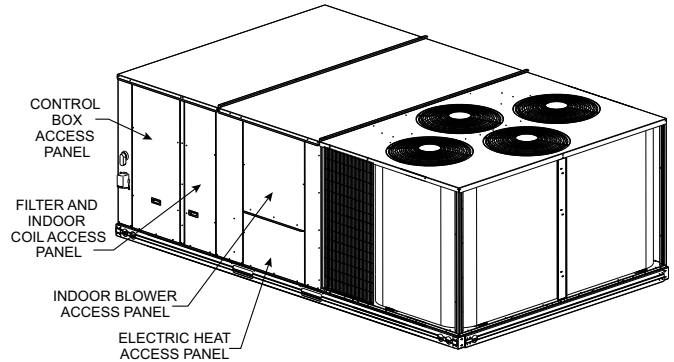

Fig. 51 — Typical Access Panel Location

Not all available heater modules may be used in every unit. Use only those heater modules that are ETL listed for use in a specific size unit. Refer to the label on the unit cabinet for the list of approved heaters.

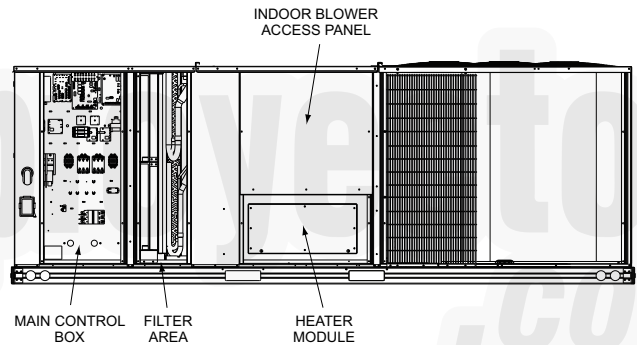

Fig. 52 — Typical Component Location

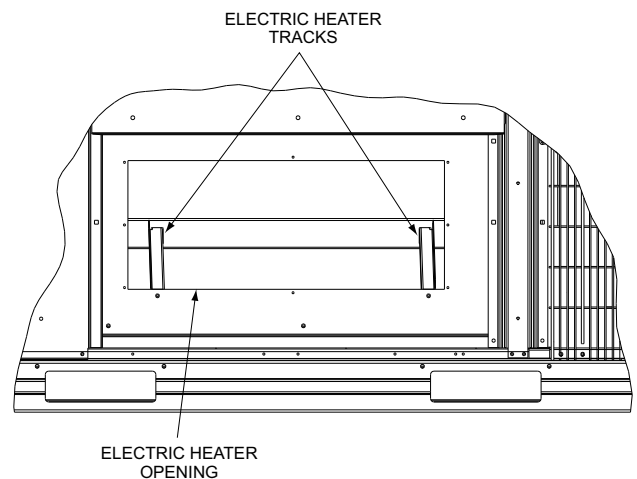

Fig. 53 — Electric Heater Compartment (Cover Removed)

LOW-VOLTAGE CONTROL CONNECTIONS

Locate the plug assembly in the electric heater section of the main unit. Connect the plug with the mating low voltage plug located on the heater. Note that the plug will already be connected when there is factory installed electric heat (see Fig. 54).

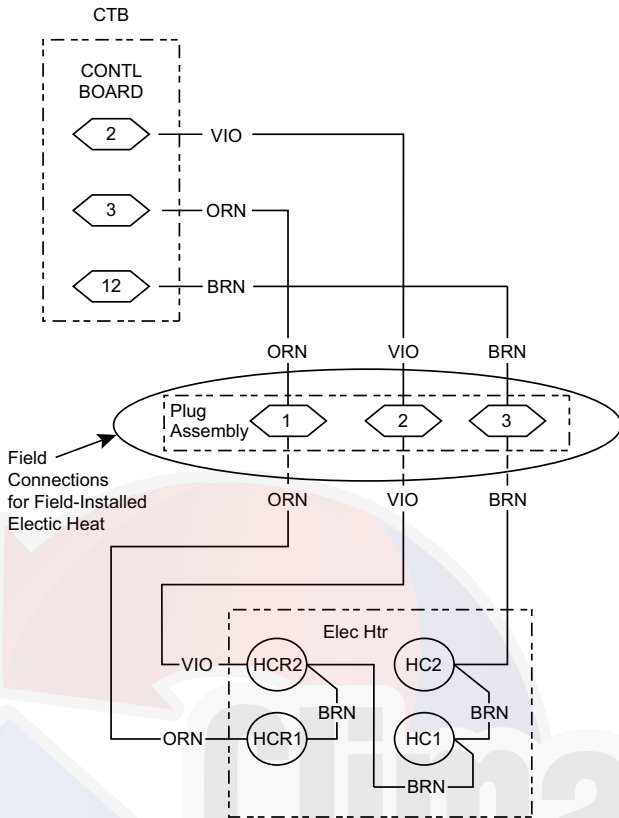

Fig. 54 — Accessory Electric Heater Control Connections

Humidi-MiZer® System Control Connections

HUMIDI-MIZER — SPACE RH CONTROLLER

NOTE: The Humidi-MiZer system is a factory-installed option.

The Humidi-MiZer dehumidification system requires a field-supplied and installed space relative humidity control device. This device may be a separate humidistat control (contact closes on rise in space RH above control setpoint, see Fig. 55) or a combination thermostat-humidistat control device such as Carrier's Edge® Pro Thermidistat with isolated contact set for dehumidification control (see Fig. 56). The humidistat is normally used in applications where a temperature control is already provided (units with PremierLink™ control).

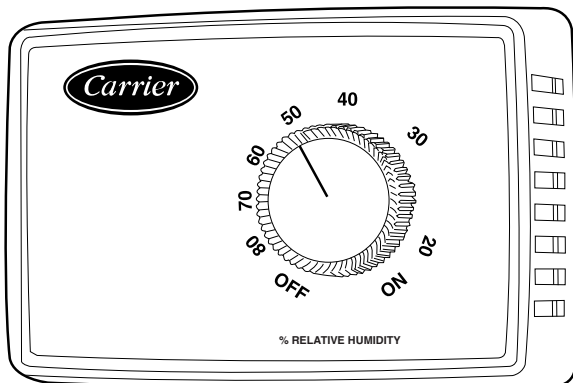

Fig. 55 — Accessory Field-Installed Humidistat



Fig. 56 — Edge® Pro Thermidistat

To connect the Carrier humidistat (HL38MG029):

1. Route the humidistat 2-conductor cable (field-supplied) through hole provided in the unit corner post.
2. Feed wires through the raceway built into the corner post (see Fig. 50) to the 24-v barrier located on the left side of the control box. The raceway provides the UL-required clearance between high-voltage and low-voltage wiring.
3. Use wire nuts to connect humidistat cable to two PINK leads in the low-voltage wiring as shown in Fig. 57).

To connect the Thermidistat device (33CS2PPRH-01):

1. Route the Thermidistat multi-conductor thermostat cable (field-supplied) through hole provided in the unit corner post.
2. Feed wires through the raceway built into the corner post (see Fig. 50) to the 24-v barrier located on the left side of the control box. The raceway provides the UL-required clearance between high-voltage and low-voltage wiring.
3. The Thermidistat has dry contacts at terminals D1 and D2 for dehumidification operation (see Fig. 58). The dry contacts must be wired between CTB terminal R and the PINK lead to the LTLO switch with field-supplied wire nuts. Refer to the installation instructions included with the Carrier Edge Pro Thermidistat device for more information.

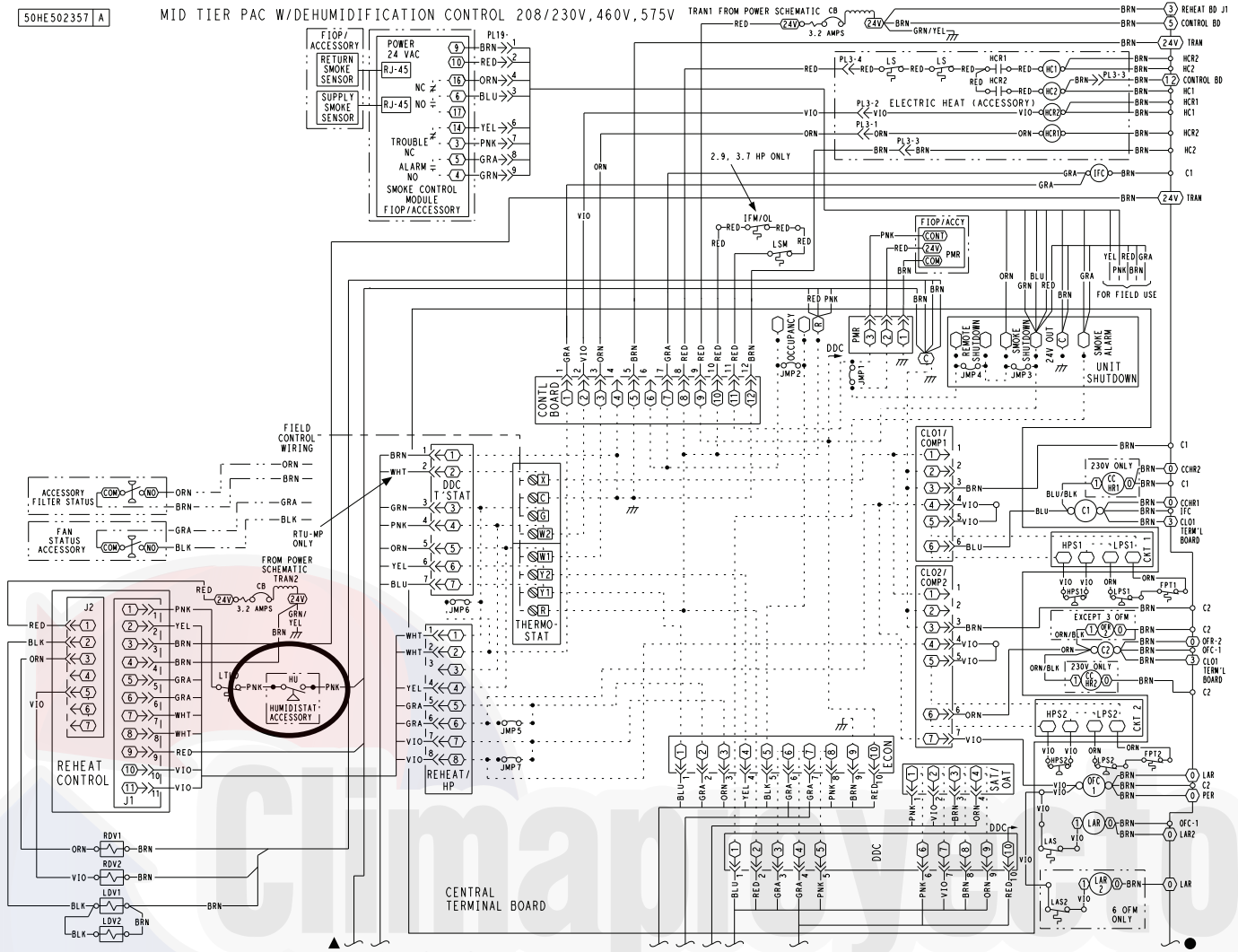
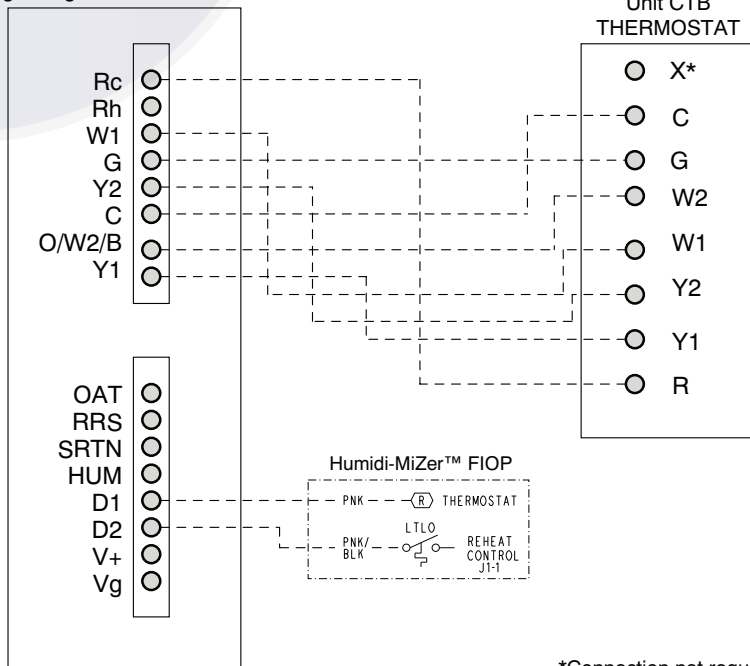

Fig. 57 — Typical Humidi-MiZer® Adaptive Dehumidification System Humidistat Wiring

Edge Programmable Thermostat



*Connection not required.

Fig. 58 — Typical Rooftop Unit with Humidi-MiZer Adaptive Dehumidification System with Edge Pro Thermidistat Device

EconoMiSer® X (Factory-Installed Option)

PRODUCT DESCRIPTION

The EconoMiSer X system is an expandable economizer control system, which includes a W7220 economizer module (controller) with an LCD and keypad (See Fig. 59). The W7220 module can be configured with optional sensors.



Fig. 59 — W7220 Economizer Module

The W7220 economizer module can be used as a stand-alone economizer module wired directly to a commercial set-back space thermostat and sensors to provide outside air dry-bulb economizer control.

The W7220 economizer module can be connected to optional sensors for single or differential enthalpy control. The W7220 economizer module provides power and communications for the sensors.

The W7220 economizer module automatically detects sensors by polling to determine which sensors are present. If a sensor loses communications after it has been detected, the W7220 economizer controller indicates a device fail error on its LCD.

SYSTEM COMPONENTS

The EconoMiSer X system includes an economizer module, 20k mixed air sensor, damper actuator, and either a 20k outdoor air temperature sensor or S-Bus enthalpy sensors.

Economizer Module

The module is the core of the EconoMiSer X system. The module is mounted in the unit's control box, and includes the user interface for the system. The W7220 economizer module provides the basic inputs and outputs to provide simple economizer control. When used with the optional sensors, the economizer module provides more advanced economizer functionality.

S-Bus Enthalpy Control Sensors

The sensor is a combination temperature and humidity sensor which is powered by and communicates on the S-Bus. Up to three sensors may be configured with the W7220 economizer module.

CO₂ Sensor (optional)

The sensor can be added for Demand Controlled Ventilation (DCV).

SPECIFICATIONS

W7220 Economizer Module

The module is designed for use with 2 to 10 Vdc or bus communicating actuator. The module includes terminals for CO₂ sensor, Mixed Air sensor, and an Outdoor Dry Bulb sensor. Enthalpy and other options are available with bus sensors.

User Interface

Provides status for normal operation, setup parameters, checkout tests, and alarm and error conditions with a 2-line 16 character LCD display and four button keypad.

Electrical

Rated Voltage — 20 to 30 Vac RMS, 50/60 Hz

Transformer — 100 va maximum system input

Nominal Power Consumption (at 24 Vac, 60 Hz) — 11.5 VA without sensors or actuators

Relay Digital Output Rating at 30 Vac (maximum power from Class 2 input only) — 1.5A run:

3.5A inrush at 0.45PF (200,000 cycles) or

7.5A inrush at 0.45PF (100,000 cycles)

External Sensors Power Output — 21 Vdc \pm 5% at 48mA

IMPORTANT: All inputs and outputs must be Class 2 wiring.

INPUTS

Sensors

NOTE: A Mixed Air (MA) analog sensor is required on all W7220 units; either an Outdoor Air (OA) sensor for dry bulb change over or an OA bus sensor for outdoor enthalpy change over is required in addition to the MA sensor. An additional Return Air (RA) bus sensor can be added to the system for differential enthalpy or dry bulb changeover. For differential dry bulb changeover a 20k ohm sensor is required in the OA and a bus sensor in the RA. DIP switch on RA bus sensor must be set in the RA position.

Dry Bulb Temperature (optional) and Mixed Air (required), 20k NTC

2-wire (18 to 22 AWG);

Temperature range: -40°F to 150°F (-40°C to 65°C)

Temperature accuracy: $-0^{\circ}\text{F}/+2^{\circ}\text{F}$

Temperature and Humidity, C7400S1000 (optional)

S-Bus; 2-wire (18 to 22 AWG)

Temperature: range: -40°F to 150°F (-40°C to 65°C)

Temperature accuracy: $-0^{\circ}\text{F}/+2^{\circ}\text{F}$

Humidity: range 0 to 100% RH with 5% accuracy.

NOTE: Up to three (3) S-Bus sensors may be connected to the W7220 economizer module. For outdoor air (OA), return air (RA) and discharge (supply) air (DA).

4 Binary Inputs

1-wire 24 Vac + common GND.

24 Vac power supply

20 to 30 Vac 50/60Hz; 100 VA Class 2 transformer.

OUTPUTS

Actuator Signal:

2 to 10 Vdc; minimum actuator impedance is 2k ohm; bus two-wire output for bus communicating actuators.

Exhaust fan, Y1, Y2 and AUX1 O:

All Relay Outputs (at 30 Vac):

Running: 1.5A maximum

Inrush: 7.5A maximum

ENVIRONMENTAL

Operating Temperature:

-40°F to 150°F (-40°C to 65°C).

Exception of display operation down to -4°F with full recovery at -4°F from exposure to -40°F.

Storage Temperature:

-40°F to 150°F (-40°C to 65°C)

Shipping Temperature:

-40°F to 150°F (-40°C to 65°C)

Relative Humidity:

5% to 95% RH non-condensing

ECONOMIZER MODULE WIRING DETAILS

Use Fig. 60 and Tables 3 and 4 to locate the wiring terminals for the Economizer module.

NOTE: The four terminal blocks are removable. You can slide out each terminal block, wire it, and then slide it back into place.

Table 3 — Economizer Module - Left Hand Terminal Blocks

| LABEL | TYPE | DESCRIPTION |
|-----------------------------------|-------------------|--|
| Top Left Terminal Block | | |
| MAT MAT | 20k NTC and COM | Mixed Air Temperature Sensor (Polarity Insensitive Connection) |
| OAT OAT | 20k NTC and COM | Outdoor Air Temperature Sensor (Polarity Insensitive Connection) |
| S-BUS S-BUS | S-BUS (Sylk* Bus) | Enthalpy Control Sensor (Polarity Insensitive Connection) |
| Bottom Left Terminal Block | | |
| IAQ 2-10 | 2-10 vdc | Air Quality Sensor Input (e.g. CO2 sensor) |
| IAQ COM | COM | Air Quality Sensor Common |
| IAQ 24V | 24 vac | Air Quality Sensor 24 vac Source |
| ACT 2-10 | 2-10 vdc | Damper Actuator Output (2-10 vdc) |
| ACT COM | COM | Damper Actuator Output Common |
| ACT 24v | 24 vac | Damper Actuator 24 vac Source |

* Sylk is a trademark of Honeywell International Inc.

Table 4 — Economizer Module - Right Hand Terminal Blocks

| LABEL | TYPE | DESCRIPTION |
|-------------------------------------|------------|--|
| Top Right Terminal Blocks | | |
| AUX2 I | 24 vac IN | The first terminal is not used. |
| OCC | 24 vac IN | Shut Down (SD) or HEAT (W) Conventional only and Heat Pump Changeover (O-B) in Heat Pump mode. |
| E-GND | E-GND | Occupied/Unoccupied Input |
| EXH1 | 24 vac OUT | Exhaust Fan 1 Output |
| AUX1 O | 24 vac OUT | Programmable: Exhaust fan 2 output or ERV or System alarm output |
| Bottom Right Terminal Blocks | | |
| Y2-I | 24 vac IN | Y2 in - Cooling Stage 2 Input from space thermostat |
| Y2-O | 24 vac OUT | Y2 out - Cooling Stage 2 Output to stage 2 mechanical cooling |
| Y1-I | 24 vac IN | Y1 in - Cooling Stage 2 Input from space thermostat |
| Y1-O | 24 vac OUT | Y1 out - Cooling Stage 2 Output to stage 2 mechanical cooling |
| C | COM | 24 vac Common |
| R | 24 vac | 24 vac Power (hot) |

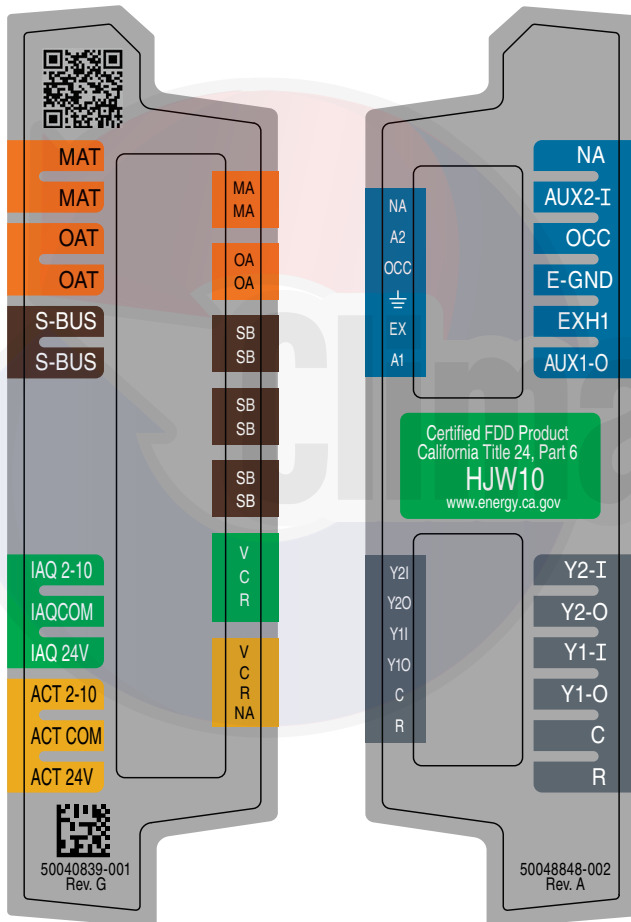

Fig. 60 — W720 Wiring Terminals

S-BUS SENSOR WIRING

The labels on the sensors and controller are color coded for ease of installation. Orange labeled sensors can only be wired to orange terminals on the controller. Brown labeled sensors can only be wired to S-bus (brown) terminals. Use Fig. 61 and Table 5 to locate the wiring terminals for each S-Bus sensor.

Use Fig. 61 and Table 5 to locate the wiring terminals for each enthalpy control sensor.

Use Fig. 61 and Table 6 to set the DIP switches for the desired use of the sensor.

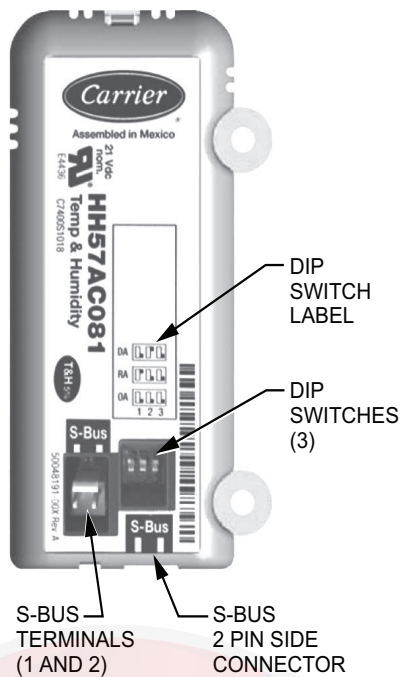

Fig. 61 — S-Bus Sensor DIP Switches

Table 5 — HH57AC081 Sensor Wiring Terminations

| TERMINAL | | TYPE | DESCRIPTION |
|----------|-------|-------|--|
| NUMBER | LABEL | | |
| 1 | S-BUS | S-BUS | S-BUS Communications (Enthalpy Control Sensor Bus) |
| 2 | S-BUS | S-BUS | S-BUS Communications (Enthalpy Control Sensor Bus) |

Table 6 — HH57AC081 Sensor DIP Switch

| USE | DIP SWITCH POSITIONS FOR SWITCHES 1, 2, AND 3 | | |
|-----|---|-----|-----|
| | 1 | 2 | 3 |
| DA | OFF | ON | OFF |
| RA | ON | OFF | OFF |
| OA | OFF | OFF | OFF |

NOTE: When a S-Bus sensor is connected to an existing network, it will take 60 minutes for the network to recognize and auto-configure itself to use the new sensor.

During the 60 minute setup period, no alarms for sensor failures (except SAT) will be issued and no economizing function will be available.

CO₂ SENSOR WIRING

When using a CO₂ sensor, the black and brown common wires are internally connected and only one is connected to “IAQ COM” on the W7220. Use the power from the W7220 to power the CO₂ sensor OR make sure the ground for the power supplies are common. See Fig. 62 for CO₂ sensor wiring.

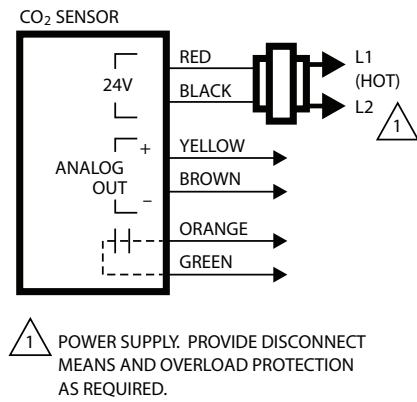

Fig. 62 — CO₂ Sensor Wiring

INTERFACE OVERVIEW

This section describes how to use the economizer’s user interface for:

- Keypad and menu navigation
- Settings and parameter changes
- Menu structure and selection

USER INTERFACE

The user interface consists of a 2-line LCD display and a 4-button keypad on the front of the economizer controller.

KEYPAD

The four navigation buttons (see Fig. 63) are used to scroll through the menus and menu items, select menu items, and to change parameter and configuration settings.

To use the keypad when working with menus:

- Press the ▲ (Up arrow) button to move to the previous menu.
- Press the ▼ (Down arrow) button to move to the next menu.
- Press the ↵ (Enter) button to display the first item in the currently displayed menu.
- Press the ⏪ (Menu Up/Exit) button to exit a menu’s item and return to the list of menus.

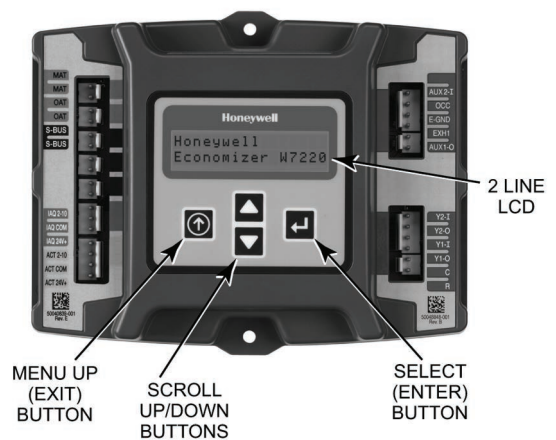

Fig. 63 — W7220 Controller Navigation Buttons

To use the keypad when working with Setpoints, System and Advanced Settings, Checkout tests and Alarms:

1. Navigate to the desired menu.
2. Press the (Enter) button to display the first item in the currently displayed menu.
3. Use the ▲ and ▼ buttons to scroll to the desired parameter.
4. Press the (Enter) button to display the value of the currently displayed item.
5. Press the ▲ button to increase (change) the displayed parameter value.
6. Press the ▼ button to decrease (change) the displayed parameter value.

NOTE: When values are displayed, pressing and holding the ▲ or ▼ button causes the display to automatically increment.

7. Press the (Enter) button to accept the displayed value and store it in nonvolatile RAM.
8. "CHANGE STORED" displays.
9. Press the (Enter) button to return to the current menu parameter.
10. Press the (Menu Up/Exit) button to return to the previous menu.

MENU STRUCTURE

Table 7 illustrates the complete hierarchy of menus and parameters for the EconoMiSer® X system.

The Menus in display order are:

- STATUS
- SETPOINTS
- SYSTEM SETUP
- ADVANCED SETUP
- CHECKOUT
- ALARMS

IMPORTANT: Table 7 illustrates the complete hierarchy. Your menu parameters may be different depending on your configuration.

For example, if you do not have a DCV (CO₂) sensor, then none of the DCV parameters appear and only MIN POS will display. If you have a CO₂ sensor, the DCV MIN and DCV MAX will appear AND if you have 2 speed fan DCV MIN (high and low speed) and DCV MAX (high and low speed will appear).

NOTE: Some parameters in the menus use the letters MA or MAT, indicating a mixed air temperature sensor location before the cooling coil. This unit application has the control sensor located after the cooling coil, in the fan section, where it is designated as (Cooling) Supply Air Temperature or SAT sensor.

SETUP AND CONFIGURATION

Before being placed into service, the W7220 Economizer module must be setup and configured for the installed system.

IMPORTANT: During setup, the economizer module is live at all times.

The setup process uses a hierarchical menu structure that is easy to use. Press the ▲ and ▼ arrow buttons to move forward and backward through the menus and press the button to select and confirm setup item changes.

TIME-OUT AND SCREENSAVER

When no buttons have been pressed for 10 minutes, the LCD displays a screen saver, which cycles through the Status items. Each Status items displays in turn and cycles to the next item after 5 seconds.

Table 7 — Menu Structure

| MENU | PARAMETER | PARAMETER DEFAULT VALUE | PARAMETER RANGE AND INCREMENT | NOTES |
|----------|-------------|-------------------------|---|--|
| STATUS | ECONO AVAIL | NO | YES/NO | FIRST STAGE COOLING DEMAND (Y1-IN) YES = economizing available; the system can use outside air for free cooling when required |
| | ECONOMIZING | NO | YES/NO | FIRST STAGE COOLING RELAY OUTPUT YES = outside air being used for 1 stage cooling |
| | OCCUPIED | NO | YES/NO | OCCUPIED YES = OCC signal received from space thermostat or unitary controller YES = 24 Vac on terminal OCC NO = 0 Vac on terminal OCC |
| | HEAT PUMP | N/A | COOL HEAT | HEAT PUMP MODE Displays COOL or HEAT when system is set to heat pump (Non-conventional) |
| | COOL Y1—IN | OFF | ON/OFF | FIRST STAGE COOLING DEMAND (Y1-IN) Y1-I signal from space thermostat or unitary controller for cooling stage 1. ON = 24 Vac on terminal Y1-I OFF = 0 Vac on terminal Y1-I |
| | COOL Y1—OUT | OFF | ON/OFF | FIRST STAGE COOLING RELAY OUTPUT Cool stage 1 Relay Output to stage 1 mechanical cooling (Y1—OUT terminal) |
| | COOL Y2—IN | OFF | ON/OFF | SECOND STAGE COOLING DEMAND (Y2-IN) Y2-I signal from space thermostat our unitary controller for second stage cooling. ON = 24 Vac on terminal Y2-I OFF = 0 Vac on terminal Y2-I |
| | COOL Y2—OUT | OFF | ON/OFF | SECOND STAGE COOLING RELAY OUTPUT Cool Stage 2 Relay Output to mechanical cooling (Y2—OUT terminal) |
| | MA TEMP | ___ . _ F | 0°F to 140°F (-18°C to 60°C) | SUPPLY AIR TEMPERATURE, Cooling Mode Displays value of measured mixed air from MAT sensor. Displays ___ . _ F if not connected, short or out-of-range. |
| | DA TEMP | ___ . _ F | 0°F to 140°F (-18°C to 60°C) | DISCHARGE AIR TEMPERATURE, after Heating section Displays when Discharge Air sensor is connected and displays measured discharge temperature. Displays ___ . _ F if sensor sends invalid value, if not connected, short or out-of-range. |
| | OA TEMP | ___ . _ F | -40°F to 140°F (-40°C to 60°C) | OUTSIDE AIR TEMP Displays measured value of outdoor air temperature. Displays ___ . _ F if sensor sends invalid value, short or out-of-range. |
| | OA HUM | __ % | 0 to 100% | OUTSIDE AIR RELATIVE HUMIDITY Displays measured value of outdoor humidity from OA sensor. Displays __ % if not connected short, or out-of-range. |
| | RA TEMP | ___ . _ F | 0°F to 140°F (-18°C to 60°C) | RETURN AIR TEMPERATURE Displays measured value of return air temperature from RAT sensor. Displays ___ . _ F if sensor sends invalid value, if not connected, short or out-of-range |
| | RA HUM | __ % | 0 to 100% | RETURN AIR RELATIVE HUMIDITY Displays measured value of return air humidity from RA sensor. Displays __ % if sensor sends invalid value, if not connected, short or out-of-range |
| | IN CO2 | ___ ppm | 0 to 2000 ppm | SPACE/RETURN AIR CO ₂ Displays value of measured CO ₂ from CO ₂ sensor. Invalid if not connected, short or out-of-range |
| | DCV STATUS | N/A | ON/OFF | DEMAND CONTROLLED VENTILATION STATUS Displays ON if above setpoint and OFF if below setpoint, and ONLY if a CO ₂ sensor is connected. |
| | DAMPER OUT | 2.0v | 2.0 to 10.0v | Displays voltage output to the damper actuator. |
| | ACT POS | N/A | 0 to 100% | Displays actual position of outdoor air damper actuator |
| | ACT COUNT | N/A | 1 to 65535 | Displays number of times actuator has cycled. 1 cycles equals 180 deg. of actuator movement in any direction. |
| | ACTUATOR | N/A | OK/Alarm (on Alarm menu) | Displays ERROR if voltage or torque is below actuator range. |
| EXH1 OUT | OFF | ON/OFF | EXHAUST STAGE 1 RELAY OUTPUT Output of EXH1 terminal: ON = relay closed OFF = relay open | |
| EXH2 OUT | OFF | ON/OFF | EXHAUST STAGE 2 RELAY OUTPUT Output of AUX terminal; displays only if AUX = EXH2 | |
| ERV | OFF | ON/OFF | ENERGY RECOVERY VENTILATOR Output of AUX terminal; displays only if AUX = ERV | |

Table 7 — Menu Structure (cont)

| MENU | PARAMETER | PARAMETER DEFAULT VALUE | PARAMETER RANGE AND INCREMENT | NOTES |
|--|---|---|--|--|
| STATUS (cont) | MECH COOL ON or HEAT STAGES ON | 0 | 0, 1, or 2 | Displays stage of mechanical cooling that is active. Displays the stage of heat pump heating that is active. |
| | FAN SPEED | N/A | LOW or HIGH | SUPPLY FAN SPEED Displays speed setting of fan on a 2-speed fan unit. |
| | W (HEAT ON) | N/A | ON/OFF | HEAT DEMAND STATUS Displays status of heat demand on a 2-speed fan unit. |
| SETPOINTS | MAT SET | 53F | 38°F to 65°F (3°C to 18°C); increment by 1°F | SUPPLY AIR SETPOINT Setpoint determines where the economizer will modulate the OA damper to maintain the mixed air temperature. |
| | LOW T LOCK | 32F | -45°F to 80°F (-43°C to 27°C); increment by 1°F | COMPRESSOR LOW TEMPERATURE LOCKOUT Setpoint determines outdoor temperature when the mechanical cooling cannot be turned on. Commonly referred to as the Compressor lockout. |
| | DRYBLB SET | 63F | 48°F to 80°F (9°C to 27°C); increment by 1°F | OA DRY BULB TEMPERATURE CHANGEOVER SETPOINT Setpoint determines where the economizer will assume outdoor air temperature is good for free cooling; e.g.; at 63°F unit will economize at 62°F and below and not economize at 64°F and above. There is a 2°F deadband. |
| | ENTH CURVE | ES3 | ES1,ES2,ES3,ES4, or ES5 | ENTHALPY CHANGEOVER CURVE Enthalpy boundary "curves" for economizing using single enthalpy. |
| | DCV SET | 1100ppm | 500 to 2000ppm; increment by 100 | DEMAND CONTROLLED VENTILATION Displays only if CO ₂ sensor is connected. Setpoint for Demand Control Ventilation of space. Above the setpoint, the OA dampers will modulate open to bring in additional OA to maintain a space ppm level below the setpoint. |
| | MIN POS | 2.8 V | 2 to 10 Vdc | VENTILATION MINIMUM POSITION Displays ONLY if a CO ₂ sensor is NOT connected. |
| | VENTMAX With 2-speed fan units VENTMAX L (low speed fan) and VENTMAX H (high speed fan) settings are required | 2.8 V | 2 to 10 Vdc | DCV MAXIMUM DAMPER POSITION Displays only if a CO ₂ sensor is connected. Used for Vbz (ventilation max cfm) setpoint. Displays 2 to 10 V if < 3 sensors (RA, OA, and MA). In AUTO mode dampers controlled by CFM. |
| | | | 100 to 9990 cfm; increment by 10 | If OA, MA, RA, and CO ₂ sensors are connected and DCV CAL ENABLE is set to AUTO mode, the OA dampers are controlled by CFM and displays from 100 to 9990 CFM. |
| | | | 2 to 10 Vdc | With 2-speed fan units VENT L (low speed fan) and MIN POS H (high speed fan) settings are required. Default for VENTMAX L is 3.2V and VENTMAX H is 2.8V |
| | VENTMIN With 2-speed fan units VENTMIN L (low speed fan) and VENTMIN H (high speed fan) set | 2.25 V | 2 to 10 Vdc or 100 to 9990 cfm increment by 10 | DCV MINIMUM DAMPER POSITION Displays only if a CO ₂ sensor is connected. Used for Ba (ventilation min cfm) setpoint. Displays 2 to 10 V if <3 sensors (RA, OA, and MA). Va is only set if DCV is used. This is the ventilation for less than maximum occupancy of the space. In AUTO mode dampers controlled by CFM. |
| | | | 100 to 9990 cfm; increment by 10 | If OA, MA, RA, and CO ₂ sensors are connected and DCV CAL ENABLE is set to AUTO mode, the OA dampers are controlled by CFM and displays from 100 to 9990 CFM. |
| 2 to 10 Vdc | | | With 2-speed fan units VENTMIN L (low speed fan) and MIN POS H (high speed fan) settings are required. Default for VENTMIN L is 3.2V and VENTMIN H is 2.8V | |
| ERV OAT SP | 32°F | 0°F to 50°F (-18°C to 10°C); increment by 1°F | ENERGY RECOVERY VENTILATOR UNIT OUTDOOR AIR TEMPERATURE SETPOINT Only when AUX1 O = ERV | |
| EXH1 SET With 2-speed fan units Exh1 L (low speed fan) and Exh1 H (high speed fan) settings are required | 50% | 0 to 100%; increment by 1 | EXHAUST FAN STAGE 1 SETPOINT Setpoint for OA damper position when exhaust fan 1 is powered by the economizer. With 2-speed fan units Exh1 L (low speed fan) and Exh1 H (high speed fan) settings are required. Default for Exh1 L is 65% and Exh1 H is 50% | |
| EXH2 SET With 2-speed fan units Exh2 L (low speed fan) and Exh2 H (high speed fan) settings are required | 75% | 0 to 100%; increment by 1 | EXHAUST FAN STAGE 2 SETPOINT Setpoint for OA damper position when exhaust fan 2 is powered by the economizer. Only used when AUX1 O is set to EHX2. With 2-speed fan units Exh2 L (low speed fan) and Exh2 H (high speed fan) settings are required. Default for Exh2 L is 80% and Exh2 H is 75% | |
| SYSTEM SETUP | INSTALL | 01/01/10 | N/A | Display order = MM/DD/YY Setting order = DD, MM, then YY. |
| | UNITS DEG | F | F or C | Sets economizer controller in degrees Fahrenheit or Celsius |
| | EQUIPMENT | CONV | Conventional or HP | CONV = conventional; HP O/B = Enable Heat Pump mode. Use AUX2 I for Heat Pump input from thermostat or controller. See Menu Note 7. |

Table 7 — Menu Structure (cont)

| MENU | PARAMETER | PARAMETER DEFAULT VALUE | PARAMETER RANGE AND INCREMENT | NOTES |
|----------------------------|-----------------|-------------------------|---|---|
| SYSTEM SETUP (cont) | AUX2 IN | W | SD/W or HP(O)/HP(B) | In CONV mode: SD + Enables configuration of shutdown (default); W = Informs controller that system is in heating mode. NOTE: If using 2-speed fan mode, you must program CONV mode for W. Shutdown is not available in 2-speed fan mode. See Menu Note 7. In HP O/B mode: HP(O) = energize heat pump on Cool (default); HP(B) = energize heat pump on heat. |
| | FAN SPEED | 2 speed | 1 speed/2 speed | Sets the economizer controller for operation of 1 speed or 2 speed supply fan. NOTE: 2-speed fan option also needs Heat (W1) programmed in AUX 2 In. See Menu Note 7. |
| | FAN CFM | 5000cfm | 100 to 15000 cfm; increment by 100 | UNIT DESIGN AIRFLOW (CFM) Enter only if using DCVAL ENA = AUTO The value is found on the nameplate label for the specific unit. |
| | AUX1 OUT | NONE | NONE ERV EXH2 SYS | Select OUTPUT for AUX1 O relay • NONE = not configured (output is not used) • ERV = Energy Recovery Ventilator • EXH2 = second damper position relay closure for second exhaust fan • SYS = use output as an alarm signal |
| | OCC | INPUT | INPUT or ALWAYS | OCCUPIED MODE BY EXTERNAL SIGNAL When using a setback thermostat with occupancy out (24 vac), the 24 vac is input "INPUT" to the OCC terminal. If no occupancy output from the thermostat then change program to "ALWAYS" OR add a jumper from terminal R to OCC terminal. |
| | FACTORY DEFAULT | NO | NO or YES | Resets all set points to factory defaults when set to YES. LCD will briefly flash YES and change to NO but all parameters will change to the factory default values. NOTE: RECHECK AUX2 IN and FANTYPE for required 2-speed values. |
| ADVANCED SETUP | MA LO SET | 45°F | 35°F to 55°F (2°C to 13°C); Incremented by 10°F | SUPPLY AIR TEMPERATURE LOW LIMIT Temperature to achieve Freeze Protection (close damper and alarm if temperature falls below setup value). |
| | FREEZE POS | CLO | CLO or MIN | FREEZE PROTECTION DAMPER POSITION Damper position when freeze protection is active (closed or MIN POS). |
| | CO2 ZERO | 0ppm | 0 to 500 ppm; Increment by 10 | CO ₂ ppm level to match CO ₂ sensor start level. |
| | CO2 SPAN | 2000ppm | 1000 to 3000 ppm; Increment by 10 | CO ₂ ppm span to match CO ₂ sensor. |
| | STG3 DLY | 2.0h | 0 min, 5 min, 15 min, then 15 min intervals. Up to 4 hrs or OFF | COOLING STAGE 3 DELAY Delay after stage 2 cool has been active. Turns on second stage of cooling when economizer is 1st stage and mechanical cooling is second stage. Allows three stages of cooling, 1 economizer and 2 mechanical. OFF = no Stage 3 cooling |
| | SD DMPR POS | CLO | CLO or OPN | Indicates shutdown signal from space thermostat or unitary controller. When controller receives 24 Vac input on the SD terminal in conventional mode, the OA damper will open if programmed for OPN and OA damper will close if programmed for CLO. All other controls, e.g., fans, etc. will shut off. |
| | DA LO ALM | 45 F (7 C) | 35°F to 65°F (2°C to 18°C); incremented by 5°F | Used for alarm for when the DA air temperature is too low. Set lower range of alarm, below this temperature the alarm will show on the display. |
| | DA HI ALM | 80 F (27 C) | 70°F to 180°F; (21°C to 82°C) Incremented by 5°F | Used for alarm for when the DA air temperature is too high. Set upper range of alarm, above this temperature the alarm will show on the display. |
| | DCV CAL ENA | MAN | MAN (manual) AUTO | Turns on the DCV automatic control of the dampers. Resets ventilation based on the RA, OA, and MA sensor conditions. Requires all 3 RA, OA, and MA sensors. |
| | MAT T CAL | 0.0°F | ±2.5°F | SUPPLY AIR TEMPERATURE CALIBRATION Allows for the operator to adjust for an out of calibration temperature sensor. |
| | OAS T CAL | 0.0°F | ±2.5°F | OUTSIDE AIR TEMPERATURE CALIBRATION Allows for the operator to adjust for an out of calibration temperature sensor. |
| | OA H CAL | 0% RH | ±10% RH | OUTSIDE AIR HUMIDITY CALIBRATION Allows for operator to adjust for an out of calibration humidity sensor. |
| | RA T CAL | 0.0°F | ±2.5°F | RETURN AIR TEMPERATURE CALIBRATION Allows for the operator to adjust for an out of calibration temperature sensor. |

Table 7 — Menu Structure (cont)

| MENU | PARAMETER | PARAMETER DEFAULT VALUE | PARAMETER RANGE AND INCREMENT | NOTES |
|-----------------------------|--|-------------------------------|---|---|
| ADVANCED SETUP (cont) | RA H CAL | 0% RH | ±10% RH | RETURN AIR HUMIDITY CALIBRATION Allows for operator to adjust for an out of calibration humidity sensor. |
| | DA T CAL | 0.0°F | ±2.5°F | DISCHARGE AIR TEMPERATURE CALIBRATION Allows for the operator to adjust for an out of calibration temperature sensor. |
| | 2SP FAN DELAY | 5 Minutes | 0 to 20 minutes in 1 minute increments | TIME DELAY ON SECOND STAGE ECONOMIZING When in economizing mode this is the delay for the high speed fan to try to satisfy the call for second stage cooling before the first stage mechanical cooling is enabled. |
| CHECKOUT | DAMPER MINIMUM POSITION | N/A | N/A | The checkout for the damper minimum position is based on the system. See Table 8. |
| | DAMPER OPEN | N/A | N/A | Position damper to the full open position. Exhaust fan contacts enable during the DAMPER OPEN test. Make sure you pause in the mode to allow exhaust contacts to energize due to the delay in the system. |
| | DAMPER CLOSE | N/A | N/A | Positions damper to the fully closed position |
| | CONNECT Y1-O | N/A | N/A | Closes the Y1-O relay (Y1-O) |
| | CONNECT Y2-O | N/A | N/A | Closes the Y2-O relay (Y2-O) |
| | CONNECT AUX1-O | N/A | N/A | Energizes the AUX output. If Aux setting is: • NONE — not action taken • ERV — 24 Vac out. Turns on or signals an ERV that the conditions are not good for economizing but are for ERV operation. • SYS — 24 Vac out. Issues a system alarm |
| CONNECT EXH1 | N/A | N/A | Closes the power exhaust fan 2 relay (EXH1) | |
| ALARMS | Alarms display only when they are active. The menu title "ALARMS(#)" includes the number of active alarms in parenthesis (). When using SYLK bus sensors, "SYLK" will appear on the screen, and when using 20k OA temperature sensors, "SENS T" will appear on the screen | | | |
| | MA T SENS ERR | N/A | N/A | SUPPLY AIR TEMPERATURE SENSOR ERROR Mixed air sensor has failed or become disconnected - check wiring then replace sensor if the alarm continues. |
| | CO2 SENS ERR | N/A | N/A | CO ₂ SENSOR ERROR CO ₂ sensor has failed, gone out of range or become disconnected - check wiring then replace sensor if the alarm continues. |
| | OA SYLK T ERR | N/A | N/A | OUTSIDE AIR S-BUS SENSOR ERROR |
| | OA SYLK H ERR | N/A | N/A | Outdoor air enthalpy sensor has failed or become disconnected - check wiring then replace sensor if the alarm continues. |
| | RA SYLK T ERR | N/A | N/A | RETURN AIR S-BUS SENSOR ERROR |
| | RA SYLK H ERR | N/A | N/A | Return air enthalpy sensor has failed or become disconnected - check wiring then replace sensor if the alarm continues. |
| | DA SYLK T ERR | N/A | N/A | DISCHARGE AIR S-BUS SENSOR ERROR Discharge air sensor has failed or become disconnected - check wiring then replace sensor if the alarm continues. |
| | OA SENS T ERR | N/A | N/A | OUTSIDE AIR TEMPERATURE SENSOR ERROR Outdoor air temperature sensor has failed or become disconnected - check wiring then replace if the alarm continues. |
| | ACT ERROR | N/A | N/A | ACTUATOR ERROR Actuator has failed or become disconnected - check for stall, over voltage, under voltage and actuator count. Replace actuator if damper is movable and supply voltage is between 21.6 V and 26.4 V. Check actuator count on STATUS menu. |
| | FREEZE ALARM | N/A | N/A | Check if outdoor temperature is below the LOW Temp Lockout on setpoint menu. Check if Mixed air temperature on STATUS menu is below the Lo Setpoint on Advanced menu. When conditions are back in normal range then the alarm will go away. |
| | SHUTDOWN ACTIVE | N/A | N/A | AUX2 IN is programmed for SHUTDOWN and 24 V has been applied to AUX2 IN terminal. |
| | DMP CAL RUNNING | N/A | N/A | DAMPER CALIBRATION ROUTINE RUNNING If DCV Auto enable has been programmed, when the W7220 is completing a calibration on the dampers, this alarm will display. Wait until the calibration is completed and the alarm will go away. Must have OA, MA and RA sensors for DCV calibration; set up in the Advanced setup menu. |
| | DA SENS ALM | N/A | N/A | DISCHARGE AIR TEMPERATURE SENSOR ALARM Discharge air temperature is out of the range set in the ADVANCED SETUP Menu. Check the temperature of the discharge air. |
| | SYS ALARM | N/A | N/A | When AUX1-O is set to SYS and there is any alarm (e.g., failed sensors, etc.), the AUX1-O terminal has 24 Vac out. |
| ACT UNDER V | N/A | N/A | ACTUATOR VOLTAGE LOW Voltage received by actuator is above expected range. | |

Table 7 — Menu Structure (cont)

| MENU | PARAMETER | PARAMETER DEFAULT VALUE | PARAMETER RANGE AND INCREMENT | NOTES |
|--------------------------|-------------|-------------------------------|-------------------------------------|--|
| ALARMS (cont) | ACT OVER V | N/A | N/A | ACTUATOR VOLTAGE HIGH Voltage received by actuator is below expected range. |
| | ACT STALLED | N/A | N/A | ACTUATOR STALLED Actuator stopped before achieving commanded position. |

LEGEND

- CLO** — Compressor Lockout
- ERV** — Energy Recovery Ventilator
- LCD** — Liquid Crystal Display
- MA** — Mixed Air
- MAT** — Mixed Air Temperature
- N/A** — Not Applicable
- OA** — Outdoor Air
- OAT** — Outdoor Air Temperature
- OCC** — Occupied
- RA** — Return Air
- RAT** — Return Air Temperature
- RTU** — Rooftop Unit
- SYS** — System

NOTES:

1. Table 7 illustrates the complete hierarchy. Your menu parameters may be different depending on your configuration. For example if you do not have a DCV (CO₂) sensor, then none of the DCV parameters appear.
2. When values are displayed, pressing and holding the ▲ or ▼ button causes the display to automatically increment.
3. ERV Operation: When in cooling mode AND the conditions are NOT OK for economizing - the ERV terminal will be energized. In the Heating mode, the ERV terminal will be energized when the OA is below the ERV OAT setpoint in the setpoint menu.

4. STATUS → OCCUPIED — The factory-standard Occupancy signal originates with a thermostat or other controller call for indoor fan operation at CTB terminal G. This signal passes through the Central Terminal Board's OCCUPIED jumper JMP1 to the ECONO connector and to the W7220's OCC input terminal. An external timeclock or relay is required to implement an Occupancy schedule on the economizer damper position.
5. STATUS → MA TEMP, SETPOINTS → MAT SET — The W7220 menu parameters and labels include designations MA, MAT and Mixed Air for the economizer cooling control sensor. On these rooftop units, the economizer control sensor is located downstream of the evaporator/indoor coil in the supply fan section where this sensor is designated as Supply Air Temperature (SAT) sensor.
6. SETPOINTS → DRYBLB SET — This point is not displayed if a Return Air (differential) temperature sensor or an Outdoor Air enthalpy sensor is connected.
7. SYSTEM SETUP parameters must be configured as noted for 2-Speed unit operation:
EQUIPMENT = CONV
AUX2 IN = W
FAN SPEED = 2SPEED

For damper minimum position settings and checkout menu readings, see Table 8. For dry bulb operation with a 1 speed indoor fan, with or without DCV, see Tables 9 and 10. For enthalpy operation with a 1 speed indoor fan, with or without DCV, see Tables 11 and 12. For dry bulb operation with a 2 speed indoor fan, with or without DCV, see Tables 13 and 14. For enthalpy operation with a 2 speed indoor fan, with or without DCV, see Tables 15 and 16.



Table 8 — Damper Minimum Position Settings and Readings on Checkout Menu

| DEMAND CONTROLLED VENTILATION (CO ₂ SENSOR) | FAN SPEED | SETPOINTS | CHECKOUT |
|--|-----------|------------|----------|
| NO | 1 | MIN POS | VMAX-HS |
| | | N/A | N/A |
| | 2 | MIN POS H | VMAX-HS |
| MIN POS L | | VMAX-LS | |
| YES | 1 | VENT MIN | VMAX-HS |
| | | VENT MAX | VMAX-HS |
| | 2 | VENT MIN H | VMAX-HS |
| | | VENT MAX H | VMAX-LS |
| | | VENT MIN L | N/A |
| | | VENT MAX L | N/A |

Table 9 — Dry Bulb Operation without DCV (CO₂ Sensor) — 1 Speed Fan

| DEMAND CONTROLLED VENTILATION (DCV) | OUTSIDE AIR GOOD TO ECONOMIZE | Y1-I | Y2-I | FAN SPEED | Y1-O | Y2-O | OCCUPIED | UNOCCUPIED |
|-------------------------------------|-------------------------------|------|------|-----------|--------|---------|----------------------|---------------------|
| NONE | No | OFF | OFF | HIGH | 0v/Off | 0v/Off | MIN POS | Closed |
| | | ON | OFF | HIGH | 24v/On | 0v/Off | MIN POS | Closed |
| | | ON | ON | HIGH | 24v/On | 24v/On | MIN POS | Closed |
| | Yes | OFF | OFF | HIGH | 0v/Off | 0v/Off | MIN POS | Closed |
| | | ON | OFF | HIGH | 0v/Off | 0v/Off | MIN POS to Full Open | Closed to Full-Open |
| | | ON | ON | HIGH | 24v/On | 0v/Off* | MIN POS to Full Open | Closed to Full-Open |

*With stage 3 delay (STG3 DLY) in Advanced setup menu can turn on second stage of mechanical cooling Y2-O after the delay if the call for Y1-I and Y2-I have not been satisfied.

Table 10 — Dry Bulb Operation with DCV (CO₂ Sensor) — 1 Speed Fan

| DEMAND CONTROLLED VENTILATION (DCV) | OUTSIDE AIR GOOD TO ECONOMIZE | Y1-I | Y2-I | FAN SPEED | Y1-O | Y2-O | OCCUPIED | UNOCCUPIED |
|-------------------------------------|-------------------------------|------|------|-----------|--------|---------|----------------------|---------------------|
| Below CO ₂ Set | No | OFF | OFF | HIGH | 0v/Off | 0v/Off | VENTMIN | Closed |
| | | ON | OFF | HIGH | 24v/On | 0v/Off | VENTMIN | Closed |
| | | ON | ON | HIGH | 24v/On | 24v/On | VENTMIN | Closed |
| | Yes | OFF | OFF | HIGH | 0v/Off | 0v/Off | VENTMIN | Closed |
| | | ON | OFF | HIGH | 0v/Off | 0v/Off | VENTMIN to Full-Open | Closed to Full-Open |
| | | ON | ON | HIGH | 24v/On | 0v/Off | VENTMIN to Full-Open | Closed to Full-Open |
| Above CO ₂ Set | No | OFF | OFF | HIGH | 0v/Off | 0v/Off | VENTMIN to VENTMAX | Closed |
| | | ON | OFF | HIGH | 24v/On | 0v/Off | VENTMIN to VENTMAX | Closed |
| | | ON | ON | HIGH | 24v/On | 24v/On | VENTMIN to VENTMAX | Closed |
| | Yes | OFF | OFF | HIGH | 0v/Off | 0v/Off | VENTMIN to VENTMAX | Closed |
| | | ON | OFF | HIGH | 0v/Off | 0v/Off | VENTMIN to Full-Open | Closed to Full-Open |
| | | ON | ON | HIGH | 24v/On | 0v/Off* | VENTMIN to Full-Open | Closed to Full-Open |

*With stage 3 delay (STG3 DLY) in Advanced setup menu can turn on second stage of mechanical cooling Y2-O after the delay if the call for Y1-I and Y2-I have not been satisfied.

Table 11 — Enthalpy Operation without DCV (CO₂ Sensor) — 1 Speed Fan

| DEMAND CONTROLLED VENTILATION (DCV) | OUTSIDE AIR GOOD TO ECONOMIZE | Y1-I | Y2-I | FAN SPEED | Y1-O | Y2-O | OCCUPIED | UNOCCUPIED |
|-------------------------------------|-------------------------------|------|------|-----------|--------|---------|----------------------|---------------------|
| NONE | No | OFF | OFF | HIGH | 0v/Off | 0v/Off | MIN POS | Closed |
| | | ON | OFF | HIGH | 24v/On | 0v/Off | MIN POS | Closed |
| | | ON | ON | HIGH | 24v/On | 24v/On | MIN POS | Closed |
| | Yes | OFF | OFF | HIGH | 0v/Off | 0v/Off | MIN POS | Closed |
| | | ON | OFF | HIGH | 0v/Off | 0v/Off | MIN POS to Full Open | Closed to Full-Open |
| | | ON | ON | HIGH | 24v/On | 0v/Off* | MIN POS to Full Open | Closed to Full-Open |

*With stage 3 delay (STG3 DLY) in Advanced setup menu can turn on second stage of mechanical cooling Y2-O after the delay if the call for Y1-I and Y2-I have not been satisfied.

Table 12 — Enthalpy Operation with DCV (CO₂ Sensor) — 1 Speed Fan

| DEMAND CONTROLLED VENTILATION (DCV) | OUTSIDE AIR GOOD TO ECONOMIZE | Y1-I | Y2-I | FAN SPEED | Y1-O | Y2-O | OCCUPIED | UNOCCUPIED |
|-------------------------------------|-------------------------------|------|------|-----------|--------|---------|----------------------|---------------------|
| Below CO ₂ Set | No | OFF | OFF | HIGH | 0v/Off | 0v/Off | VENTMIN | Closed |
| | | ON | OFF | HIGH | 24v/On | 0v/Off | VENTMIN | Closed |
| | | ON | ON | HIGH | 24v/On | 24v/On | VENTMIN | Closed |
| | Yes | OFF | OFF | HIGH | 0v/Off | 0v/Off | VENTMIN | Closed |
| | | ON | OFF | HIGH | 0v/Off | 0v/Off | VENTMIN to Full-Open | Closed to Full-Open |
| | | ON | ON | HIGH | 24v/On | 0v/Off | VENTMIN to Full-Open | Closed to Full-Open |
| Above CO ₂ Set | No | OFF | OFF | HIGH | 0v/Off | 0v/Off | VENTMIN to VENTMAX | Closed |
| | | ON | OFF | HIGH | 24v/On | 0v/Off | VENTMIN to VENTMAX | Closed |
| | | ON | ON | HIGH | 24v/On | 24v/On | VENTMIN to VENTMAX | Closed |
| | Yes | OFF | OFF | HIGH | 0v/Off | 0v/Off | VENTMIN to VENTMAX | Closed |
| | | ON | OFF | HIGH | 0v/Off | 0v/Off | VENTMIN to Full-Open | Closed to Full-Open |
| | | ON | ON | HIGH | 24v/On | 0v/Off* | VENTMIN to Full-Open | Closed to Full-Open |

*With stage 3 delay (STG3 DLY) in Advanced setup menu can turn on second stage of mechanical cooling Y2-O after the delay if the call for Y1-I and Y2-I have not been satisfied.

Table 13 — Dry Bulb Operation without DCV (CO₂ Sensor) — 2 Speed Fan

| DEMAND CONTROLLED VENTILATION (DCV) | OUTSIDE AIR GOOD TO ECONOMIZE | Y1-I | Y2-I | FAN SPEED | Y1-O | Y2-O | OCCUPIED | UNOCCUPIED |
|-------------------------------------|-------------------------------|------|------|-----------|--------|---------|----------------------|---------------------|
| NONE | No | OFF | OFF | LOW | 0v/Off | 0v/Off | MIN POS | Closed |
| | | ON | OFF | LOW | 24v/On | 0v/Off | MIN POS | Closed |
| | | ON | ON | HIGH | 24v/On | 24v/On | MIN POS | Closed |
| | Yes | OFF | OFF | LOW | 0v/Off | 0v/Off | MIN POS | Closed |
| | | ON | OFF | LOW | 0v/Off | 0v/Off | MIN POS to Full Open | Closed to Full-Open |
| | | ON | ON | HIGH | 24v/On | 0v/Off* | MIN POS to Full Open | Closed to Full-Open |

*With stage 3 delay (STG3 DLY) in Advanced setup menu can turn on second stage of mechanical cooling Y2-O after the delay if the call for Y1-I and Y2-I have not been satisfied.

Table 14 — Dry Bulb Operation with DCV (CO₂ Sensor) — 2 Speed Fan

| DEMAND CONTROLLED VENTILATION (DCV) | OUTSIDE AIR GOOD TO ECONOMIZE | Y1-I | Y2-I | FAN SPEED | Y1-O | Y2-O | OCCUPIED | UNOCCUPIED |
|-------------------------------------|-------------------------------|------|------|-----------|--------|---------|----------------------|---------------------|
| Below CO ₂ Set | No | OFF | OFF | LOW | 0v/Off | 0v/Off | VENTMIN | Closed |
| | | ON | OFF | LOW | 24v/On | 0v/Off | VENTMIN | Closed |
| | | ON | ON | HIGH | 24v/On | 24v/On | VENTMIN | Closed |
| | Yes | OFF | OFF | LOW | 0v/Off | 0v/Off | VENTMIN | Closed |
| | | ON | OFF | LOW | 0v/Off | 0v/Off | VENTMIN to Full-Open | Closed to Full-Open |
| | | ON | ON | HIGH | 24v/On | 0v/Off | VENTMIN to Full-Open | Closed to Full-Open |
| Above CO ₂ Set | No | OFF | OFF | LOW | 0v/Off | 0v/Off | VENTMIN to VENTMAX | Closed |
| | | ON | OFF | LOW | 24v/On | 0v/Off | VENTMIN to VENTMAX | Closed |
| | | ON | ON | HIGH | 24v/On | 24v/On | VENTMIN to VENTMAX | Closed |
| | Yes | OFF | OFF | LOW | 0v/Off | 0v/Off | VENTMIN to VENTMAX | Closed |
| | | ON | OFF | LOW | 0v/Off | 0v/Off | VENTMIN to Full-Open | Closed to Full-Open |
| | | ON | ON | HIGH | 24v/On | 0v/Off* | VENTMIN to Full-Open | Closed to Full-Open |

*With stage 3 delay (STG3 DLY) in Advanced setup menu can turn on second stage of mechanical cooling Y2-O after the delay if the call for Y1-I and Y2-I have not been satisfied.

Table 15 — Enthalpy Operation without DCV (CO₂ Sensor) — 2 Speed Fan

| DEMAND CONTROLLED VENTILATION (DCV) | OUTSIDE AIR GOOD TO ECONOMIZE | Y1-I | Y2-I | FAN SPEED | Y1-O | Y2-O | OCCUPIED | UNOCCUPIED |
|-------------------------------------|-------------------------------|------|------|-----------|--------|---------|----------------------|---------------------|
| NO CO ₂ SENSOR | No | OFF | OFF | LOW | 0v/Off | 0v/Off | MIN POS | Closed |
| | | ON | OFF | LOW | 24v/On | 0v/Off | MIN POS | Closed |
| | | ON | ON | HIGH | 24v/On | 24v/On | MIN POS | Closed |
| | Yes | OFF | OFF | LOW | 0v/Off | 0v/Off | MIN POS | Closed |
| | | ON | OFF | LOW | 0v/Off | 0v/Off | MIN POS to Full Open | Closed to Full-Open |
| | | ON | ON | HIGH | 24v/On | 0v/Off* | MIN POS to Full Open | Closed to Full-Open |

*With stage 3 delay (STG3 DLY) in Advanced setup menu can turn on second stage of mechanical cooling Y2-O after the delay if the call for Y1-I and Y2-I have not been satisfied.

Table 16 — Enthalpy Operation with DCV (CO₂ Sensor) — 2 Speed Fan

| DEMAND CONTROLLED VENTILATION (DCV) | OUTSIDE AIR GOOD TO ECONOMIZE | Y1-I | Y2-I | FAN SPEED | Y1-O | Y2-O | OCCUPIED | UNOCCUPIED |
|-------------------------------------|-------------------------------|------|------|-----------|--------|---------|----------------------|---------------------|
| Below CO ₂ Set | No | OFF | OFF | LOW | 0v/Off | 0v/Off | VENTMIN | Closed |
| | | ON | OFF | LOW | 24v/On | 0v/Off | VENTMIN | Closed |
| | | ON | ON | HIGH | 24v/On | 24v/On | VENTMIN | Closed |
| | Yes | OFF | OFF | LOW | 0v/Off | 0v/Off | VENTMIN | Closed |
| | | ON | OFF | LOW | 0v/Off | 0v/Off | VENTMIN to Full-Open | Closed to Full-Open |
| | | ON | ON | HIGH | 24v/On | 0v/Off | VENTMIN to Full-Open | Closed to Full-Open |
| Above CO ₂ Set | No | OFF | OFF | LOW | 0v/Off | 0v/Off | VENTMIN to VENTMAX | Closed |
| | | ON | OFF | LOW | 24v/On | 0v/Off | VENTMIN to VENTMAX | Closed |
| | | ON | ON | HIGH | 24v/On | 24v/On | VENTMIN to VENTMAX | Closed |
| | Yes | OFF | OFF | LOW | 0v/Off | 0v/Off | VENTMIN to VENTMAX | Closed |
| | | ON | OFF | LOW | 0v/Off | 0v/Off | VENTMIN to Full-Open | Closed to Full-Open |
| | | ON | ON | HIGH | 24v/On | 0v/Off* | VENTMIN to Full-Open | Closed to Full-Open |

*With stage 3 delay (STG3 DLY) in Advanced setup menu can turn on second stage of mechanical cooling Y2-O after the delay if the call for Y1-I and Y2-I have not been satisfied.

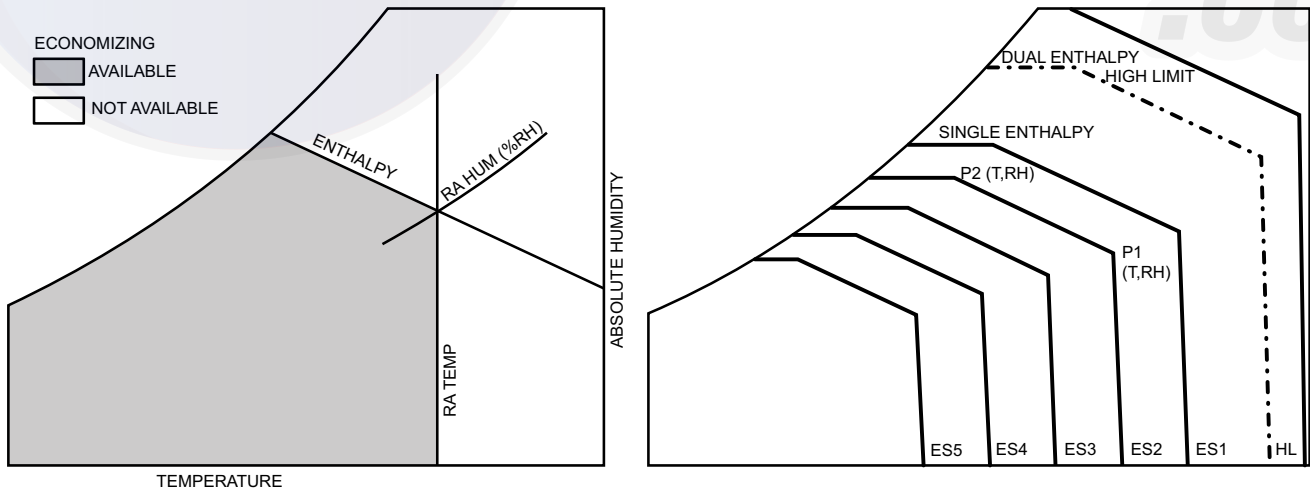

Fig. 64 — Single Enthalpy Curve Boundaries

Table 17 — Single Enthalpy and Dual Enthalpy High Limit Curves

| ENTHALPY CURVE | TEMP. DRY BULB (F) | TEMP. DEWPOINT (F) | ENTHALPY (btu/lb/da) | POINT P1 | | POINT P2 | |
|----------------|--------------------|--------------------|----------------------|-----------|----------------|-----------|----------------|
| | | | | TEMP. (F) | HUMIDITY (%RH) | TEMP. (F) | HUMIDITY (%RH) |
| ES1 | 80 | 60 | 28.0 | 80 | 36.8 | 66.3 | 80.1 |
| ES2 | 75 | 57 | 26.0 | 75 | 39.6 | 63.3 | 80.0 |
| ES3 | 70 | 54 | 24.0 | 70 | 42.3 | 59.7 | 81.4 |
| ES4 | 65 | 51 | 22.0 | 65 | 44.8 | 55.7 | 84.2 |
| ES5 | 60 | 48 | 20.0 | 60 | 46.9 | 51.3 | 88.5 |
| HL | 86 | 66 | 32.4 | 86 | 38.9 | 72.4 | 80.3 |

ENTHALPY SETTINGS

When the OA temperature, enthalpy and dew point are below the respective setpoints, the Outdoor Air can be used for economizing. Figure 64 shows the new single enthalpy boundaries in the W7220. There are 5 boundaries (setpoints ES1 through ES5), which are defined by dry bulb temperature, enthalpy and dew point.

Refer to Table 17 for ENTH CURVE setpoint values.

The W7220 calculates the enthalpy and dew point using the OA temperature and humidity input from the OA enthalpy sensor. When the OA temperature, OA humidity and OA dew point are all below the selected boundary, the economizer sets the economizing mode to YES, economizing is available.

When all of the OA conditions are above the selected boundary, the conditions are not good to economize and the mode is set to NO.

Figure 64 shows the 5 current boundaries. There is also a high limit boundary for differential enthalpy. The high limit boundary is ES1 when there are no stages of mechanical cooling energized and HL (high limit) when a compressor stage is energized.

Table 17 provides the values for each boundary limit.

TWO-SPEED FAN OPERATION

The W7220 controller has the capability to work with a system using a 2-speed supply fan. The W7220 does not control the supply directly but uses the following input status to determine the speed of the supply fan and controls the OA damper to the required position, see Table 18.

Table 18 — Fan Speed

| STATE | FAN SPEED |
|-------|-----------|
| OCC | Low |
| Y1 | Low |
| Y2 | High |
| W | High |

The W (heating mode) is not controlled by the W7220 but it requires the status to know where to position the OA damper for minimum position for the fan speed.

The 2 speed fan delay is available when the system is programmed for 2 speed fan (in the System Setup menu item). The 2 speed fan delay is defaulted to 5 minutes and can be changed in the Advanced Setup menu item. When the unit has a call for Y1 In and in the free cooling mode and there is a call for Y2 In, the 2-speed fan delay starts and the OA damper will modulate 100% open, the supply fan should be set to high speed by the unit controller.

After the delay, one of two actions will happen:

- The Y2 In call will be satisfied with the damper 100% open and fan on high speed and the call will turn off

OR

- If the call for additional cooling in the space has not been satisfied, then the first stage of mechanical cooling will be enabled through Y1 Out or Y2 Out.

CHECKOUT

Inspect all wiring connections at the economizer module’s terminals, and verify compliance with the installation wiring diagrams.

For checkout, review the Status of each configured parameter and perform the Checkout tests.

NOTE: For information about menu navigation and use of the keypad, see Interface Overview on page 39.

⚠ WARNING

ELECTRIC SHOCK HAZARD

Failure to follow this warning could result in personal injury, property damage, or death.

Before performing service or maintenance operations on unit, always turn off main power switch to unit and install lock(s) and lockout tag(s). Unit may have more than one power switch. Ensure electrical service to rooftop unit agrees with voltage and amperage listed on the unit rating plate.

If any wiring changes are required, first be sure to remove power from the economizer module before starting work. Pay particular attention to verifying the power connection (24 vac).

Power Up

After the W7220 module is mounted and wired, apply power.

Initial Menu Display

On initial start-up, Honeywell displays on the first line and economizer W7220 on the second line. After a brief pause, the revision of the software appears on the first line and the second line will be blank.

Power Loss (Outage or Brownout)

All setpoints and advanced settings are restored after any power loss or interruption.

NOTE: All settings are stored in non-volatile flash memory.

Status

Use the Status menu (see Table 7) to check the parameter values for the various devices and sensors configured.

NOTE: For information about menu navigation and use of the keypad, see Interface Overview on page 39.

Checkout Tests

Use the Checkout menu (on page 44) to test the damper operation and any configured outputs. Only items that are configured are shown in the Checkout menu.

NOTE: For information about menu navigation and use of the keypad, see Interface Overview on page 39.

To perform a Checkout test:

1. Scroll to the desired test in the Checkout menu using the ▲ and ▼ buttons.
2. Press the ↵ button to select the item.
3. RUN? appears.
4. Press the ↵ button to start the test.
5. The unit pauses and then displays IN PROGRESS.
6. When the test is complete, DONE appears.
7. When all desired parameters have been tested, press the ⬆ (Menu Up) button to end the test.

The Checkout tests can all be performed at the time of installation or at any time during the operation of the system as a test that the system is operable.

TROUBLESHOOTING

Alarms

The economizer module provides alarm messages that display on the 2-line LCD.

NOTE: Upon power up, the module waits 60 minutes before checking for alarms. This allows time for all the configured devices (e.g. sensors, actuator) to become operational. The exception is the SAT sensor, which will alarm immediately.

If one or more alarms are present and there has been no keypad activity for at least 5 minutes, the Alarms menu displays and cycles through the active alarms.

You can also navigate to the Alarms menu at any time.

Clearing Alarms

Once the alarm has been identified and the cause has been removed (e.g. replaced faulty sensor), the alarm can be cleared from the display.

To clear an alarm, perform the following:

1. Navigate to the desired alarm.
2. Press the ↵ button.
3. ERASE? displays.
4. Press the ↵ button.
5. ALARM ERASED displays.
6. Press the (Menu up/Exit) button to complete the action and return to the previous menu.

NOTE: If the alarm still exists after you clear it, it is redisplayed within 5 seconds.

⚠ CAUTION

EQUIPMENT DAMAGE HAZARD

Failure to follow this caution may result in equipment damage. Be sure to allow enough time for compressor start-up and shutdown between checkout tests so that you do not short-cycle the compressors.

Low Ambient Control (Factory Option)

If the unit comes with Electro-Mechanical (EM) control, then no adjustment is necessary.

If the unit comes with PremierLink or RTU Open control option, then refer to its installation control manual for details on adjusting “Cooling Lock-Out” setting and configure for your specific job requirements.

Staged Air Volume (SAV) with Variable Frequency Drive (Factory Option)

For details on operating 50HC 2 stage cooling units equipped with the factory-installed Staged Air Volume option, refer to the Variable Frequency Drive (VFD) Installation, Setup and Troubleshooting Supplement.

PremierLink™ Control

For details on operating units equipped with the factory-installed PremierLink controller option, refer to the *PremierLink Retrofit Rooftop Controller Version 3.x Installation, Start-Up, and Configuration Instructions* manual.

See Fig. 65 and 66 for PremierLink wiring diagrams.

RTU Open Control System

For details on operating units equipped with the factory-installed RTU Open controller, refer to the *Factory-Installed RTU Open Multi-Protocol Controller Control, Start-Up, Operation and Troubleshooting* manual.

See Fig. 67 and 68 for RTU Open wiring diagrams.

Wiring Diagrams

See Fig. 69-80 for wiring diagrams.

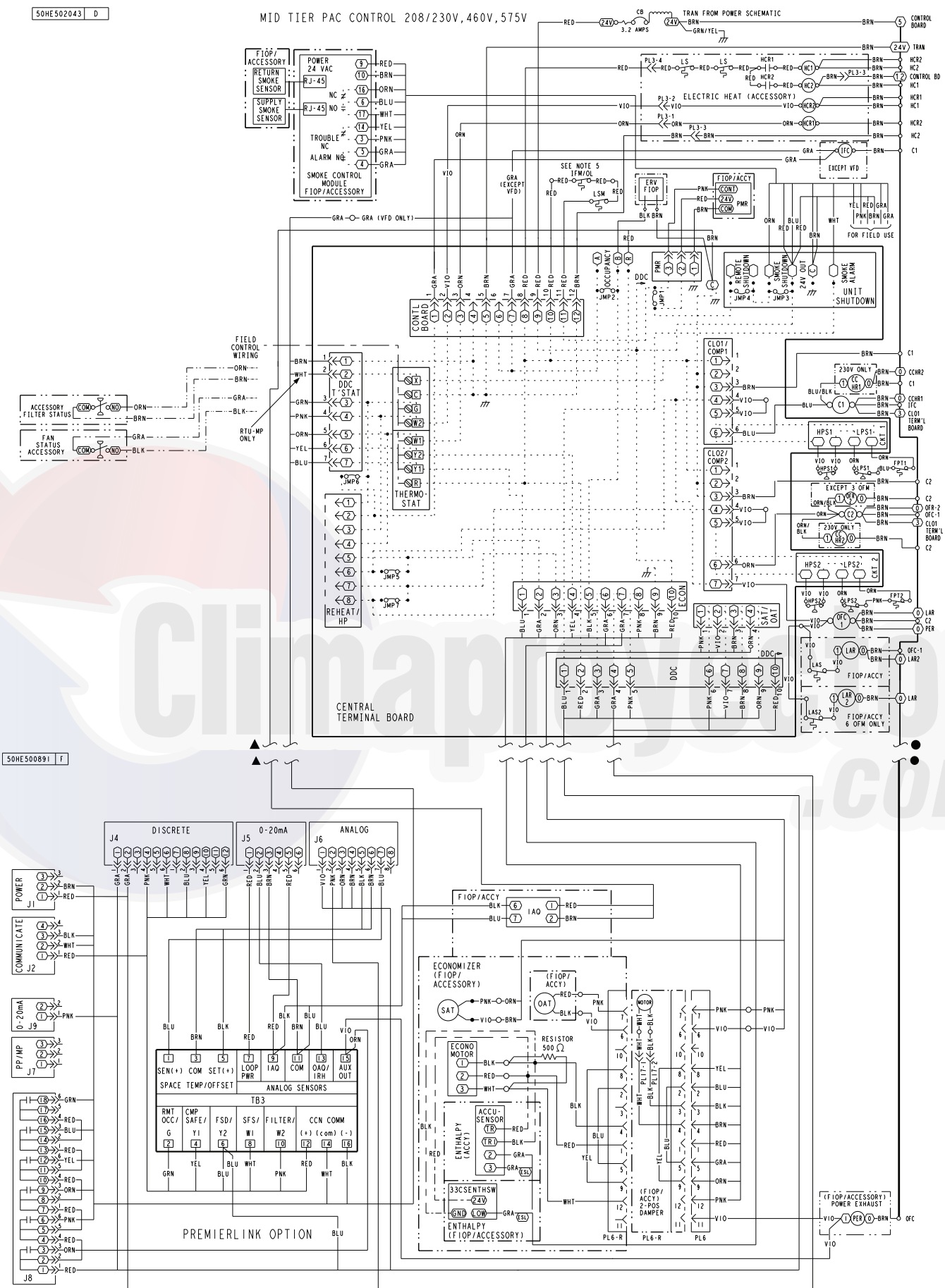

Fig. 65 — PremierLink Wiring Schematic

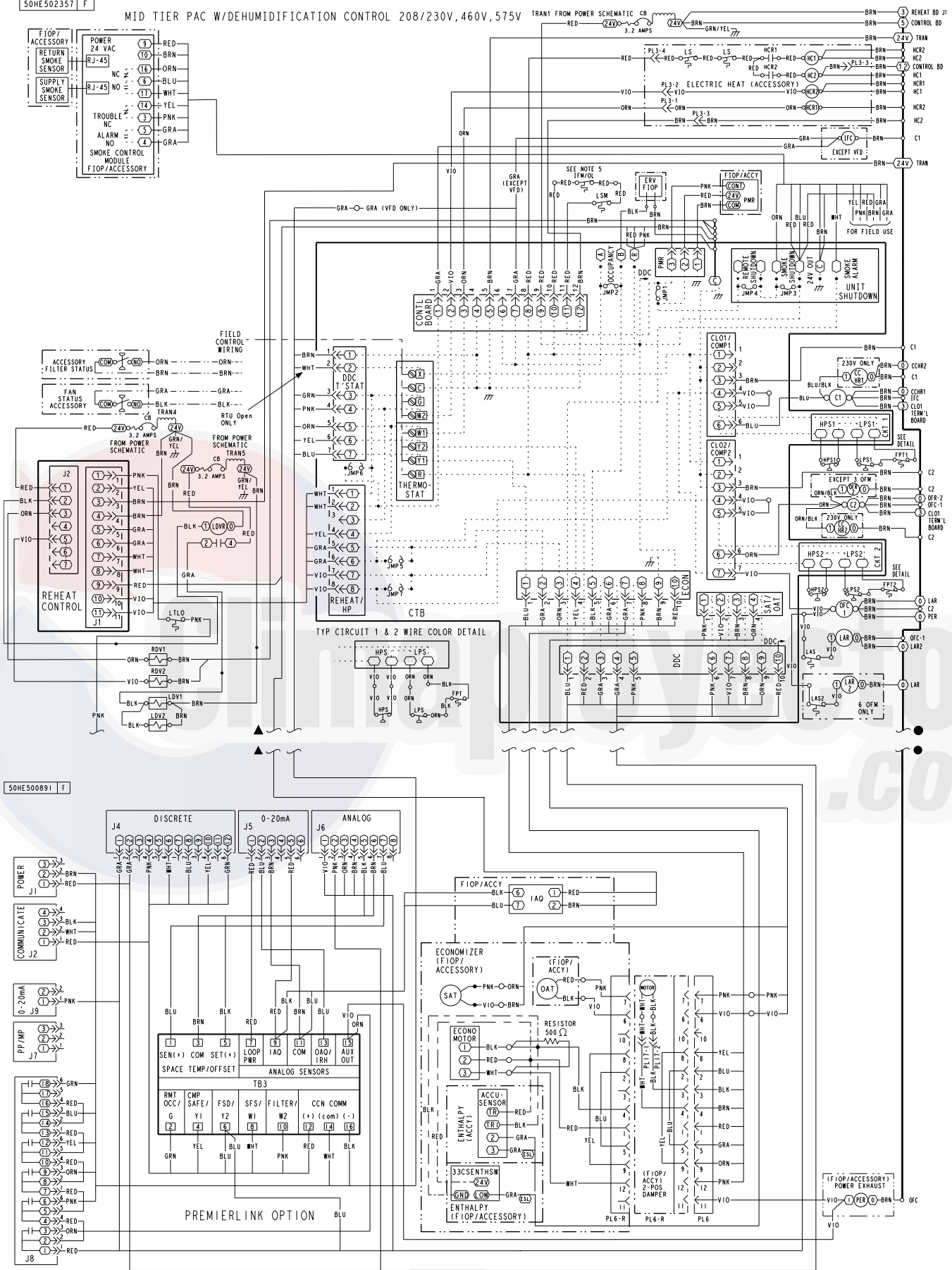

Fig. 66 — PremierLink™ Wiring Schematic with Humidi-MiZer® System Option

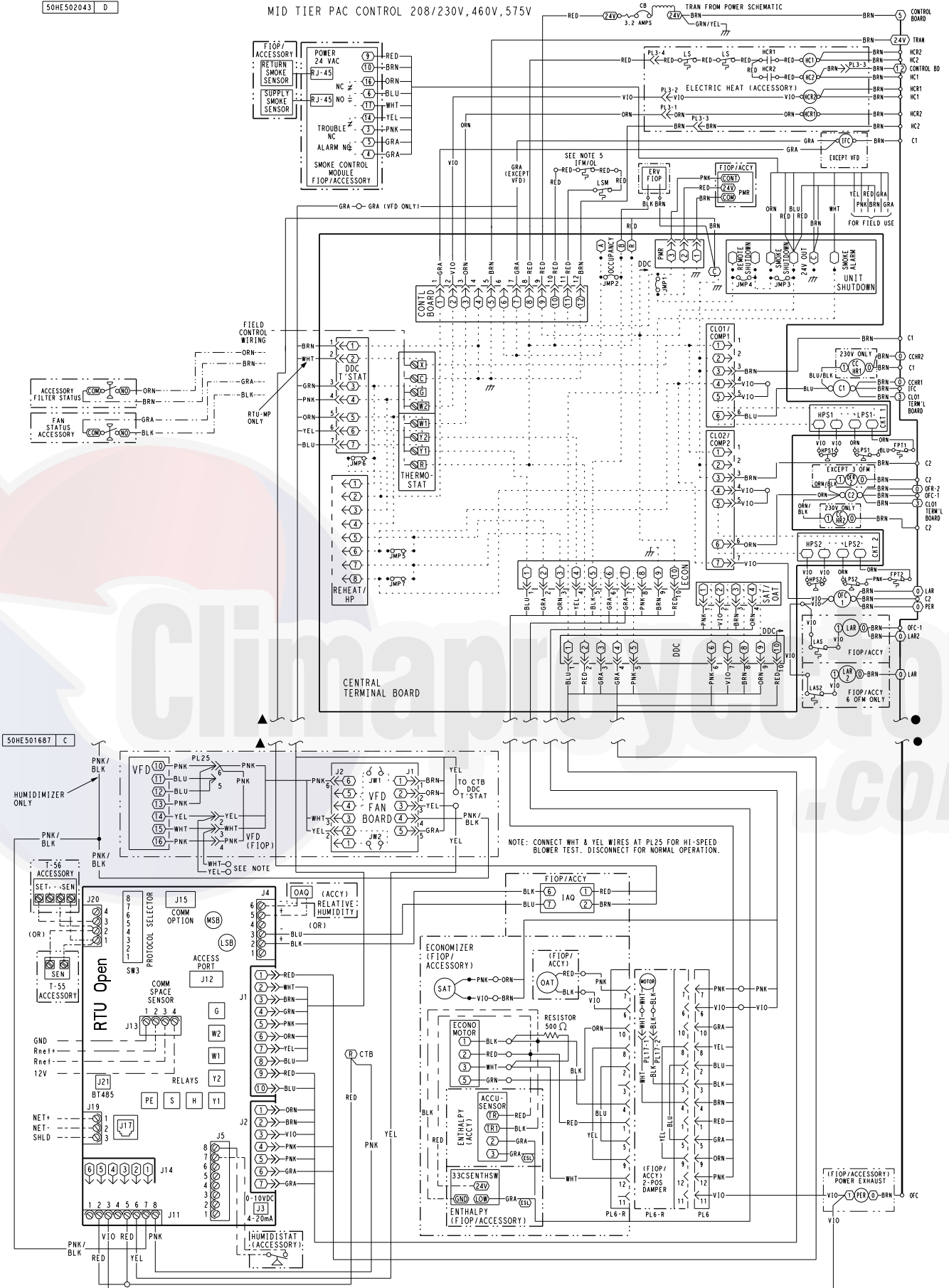

Fig. 67 — RTU Open System Control Wiring Diagram

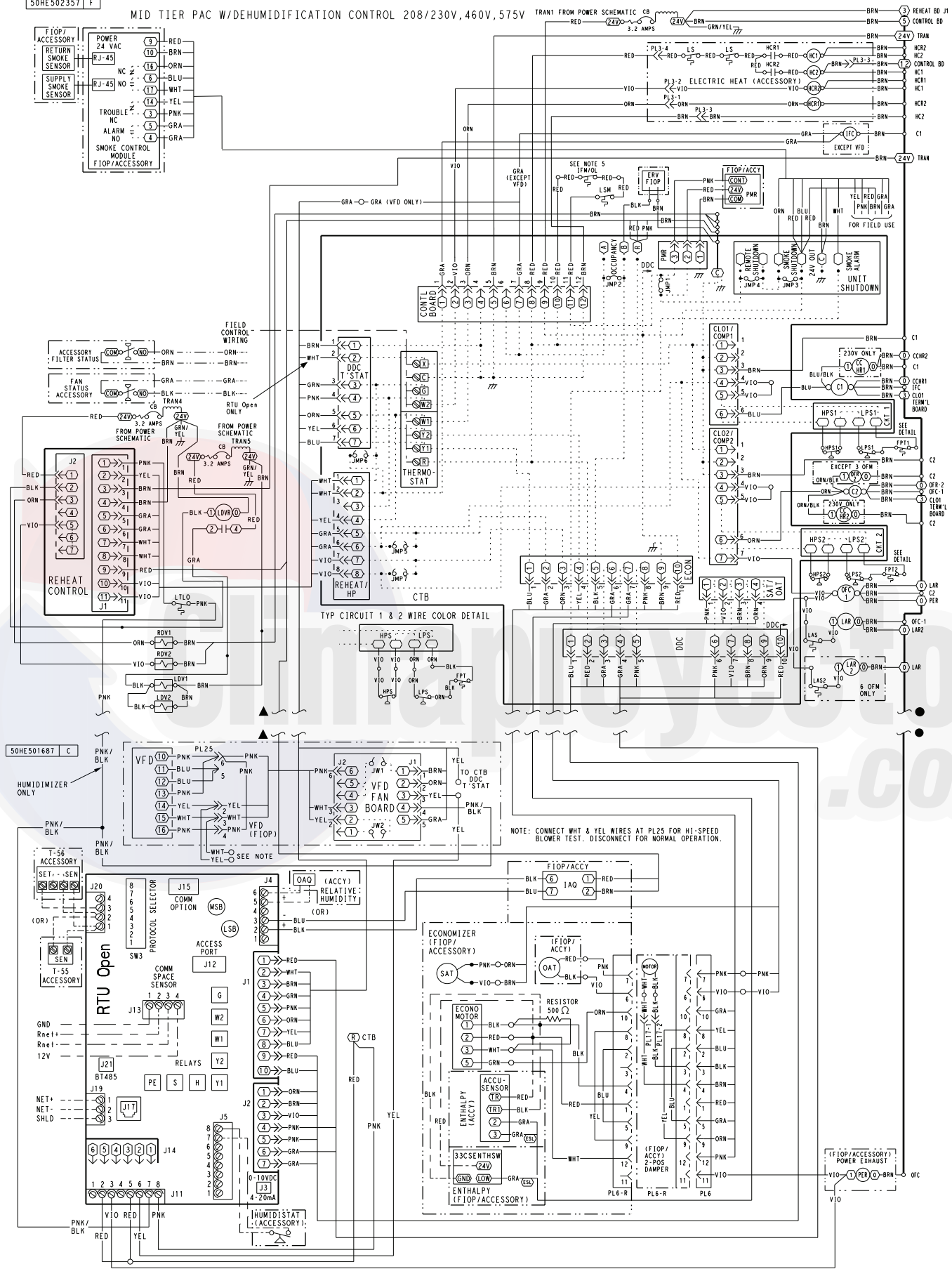

Fig. 68 — RTU Open System Control Wiring Diagram with Humidi-MiZer® System Option

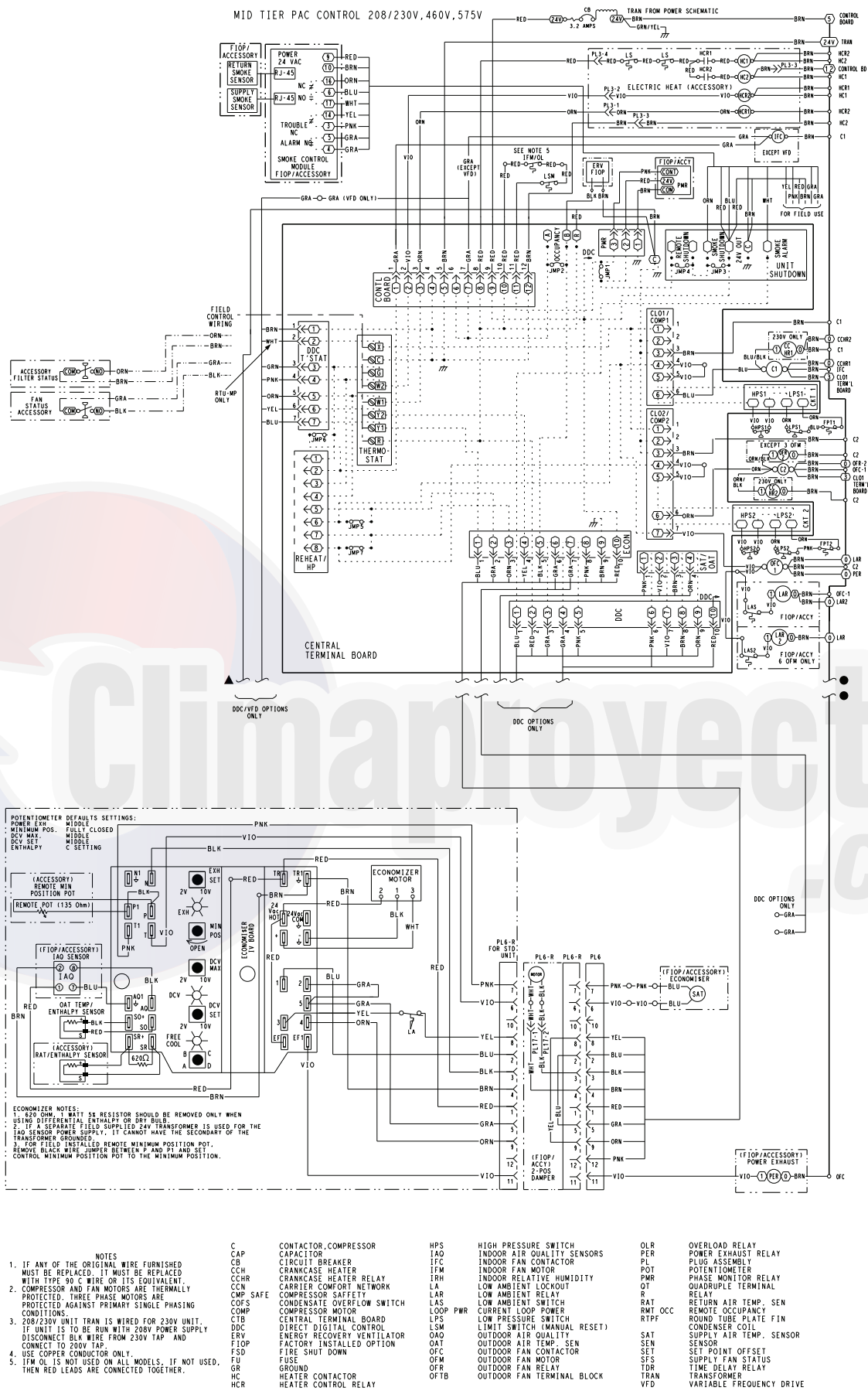

Fig. 69 — 50HC Control Diagram — D17-D24 (208/230-3-60, 460/575-3-60); D28 (460/575-3-60)

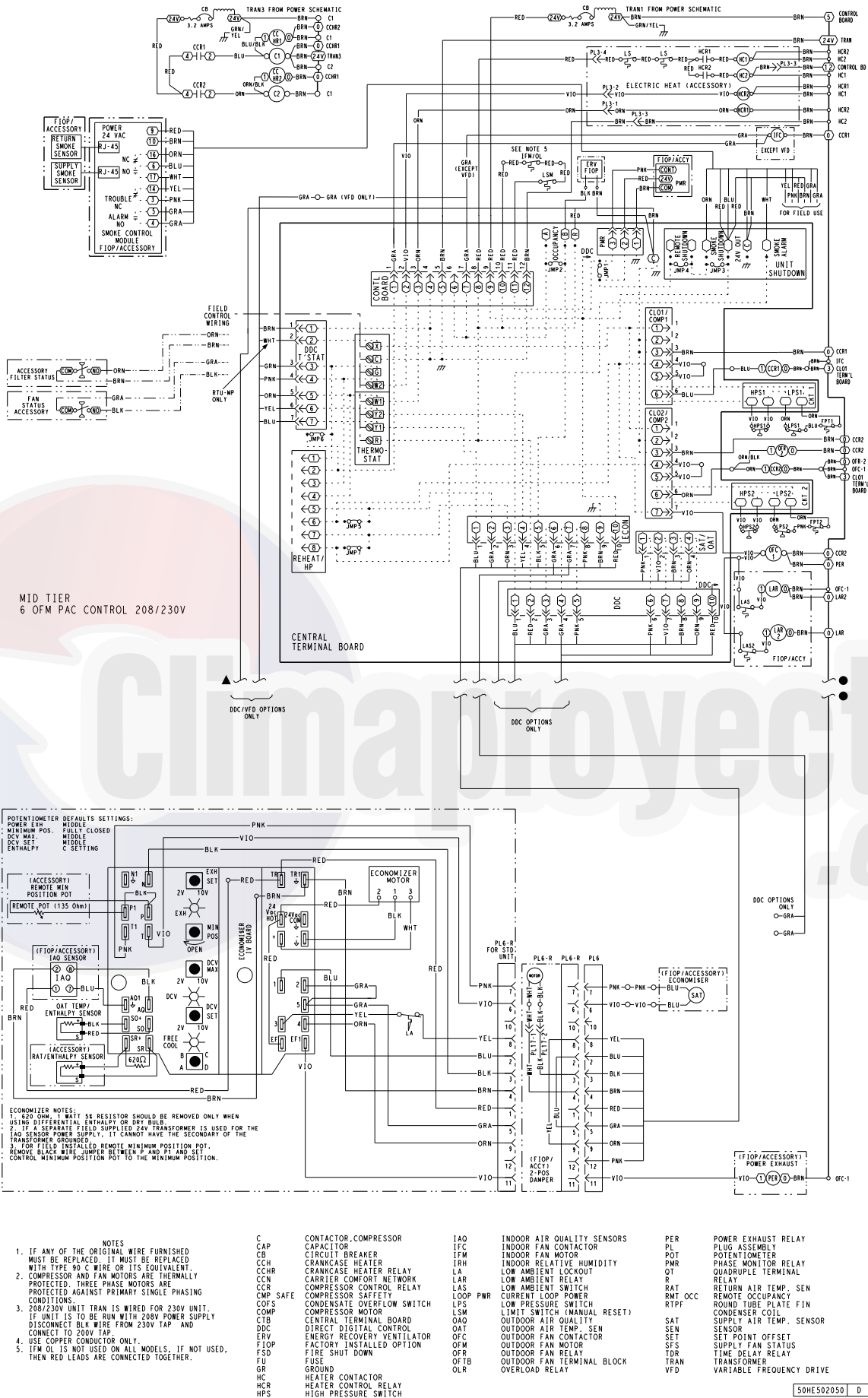

Fig. 70 — 50HC Control Diagram for D28 (208/230-3-60)

MID TIER PAC POWER 208/230V 3 PH

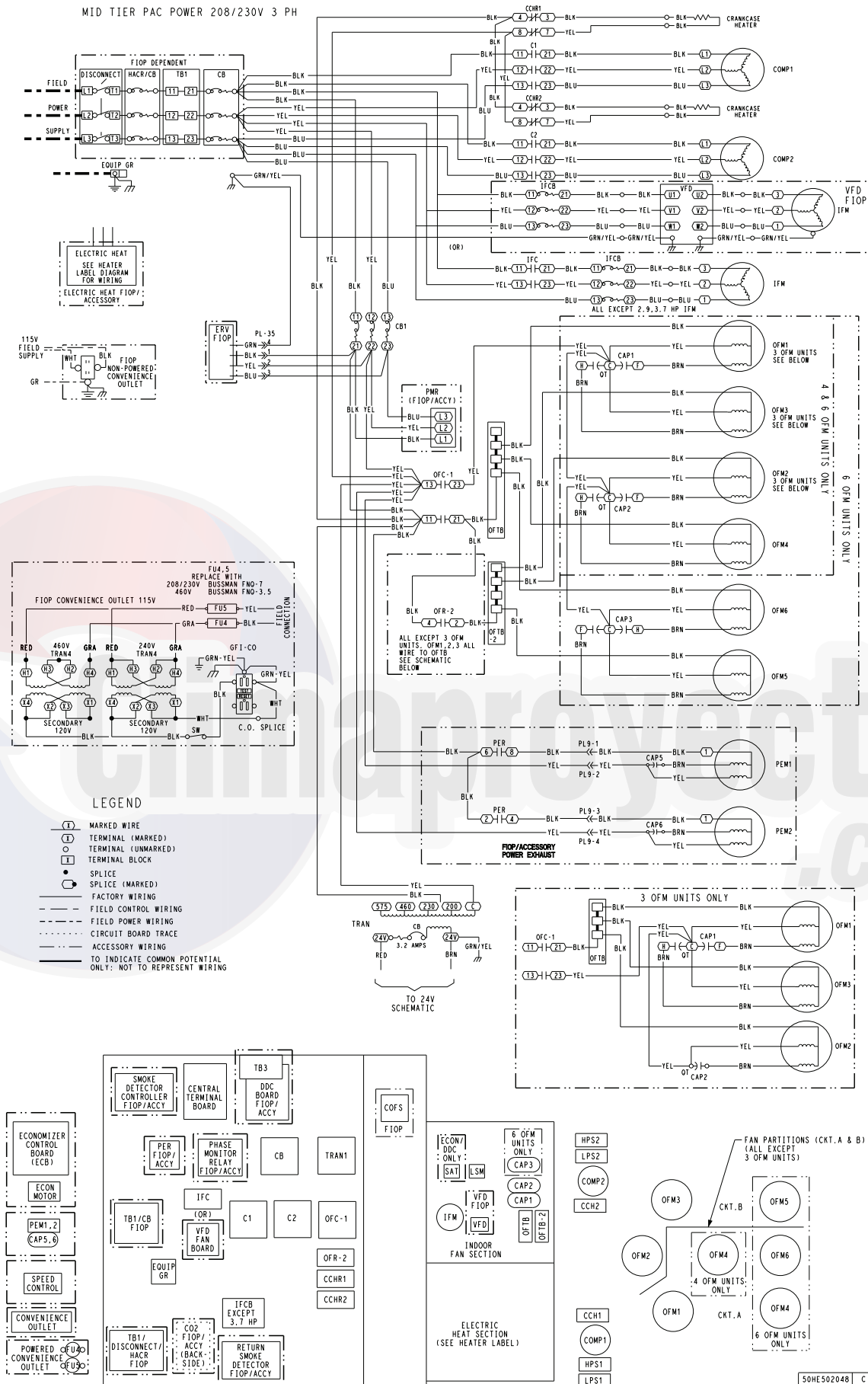

Fig. 71 — 50HC D17-D24 Power Diagram (208/230-3-60)

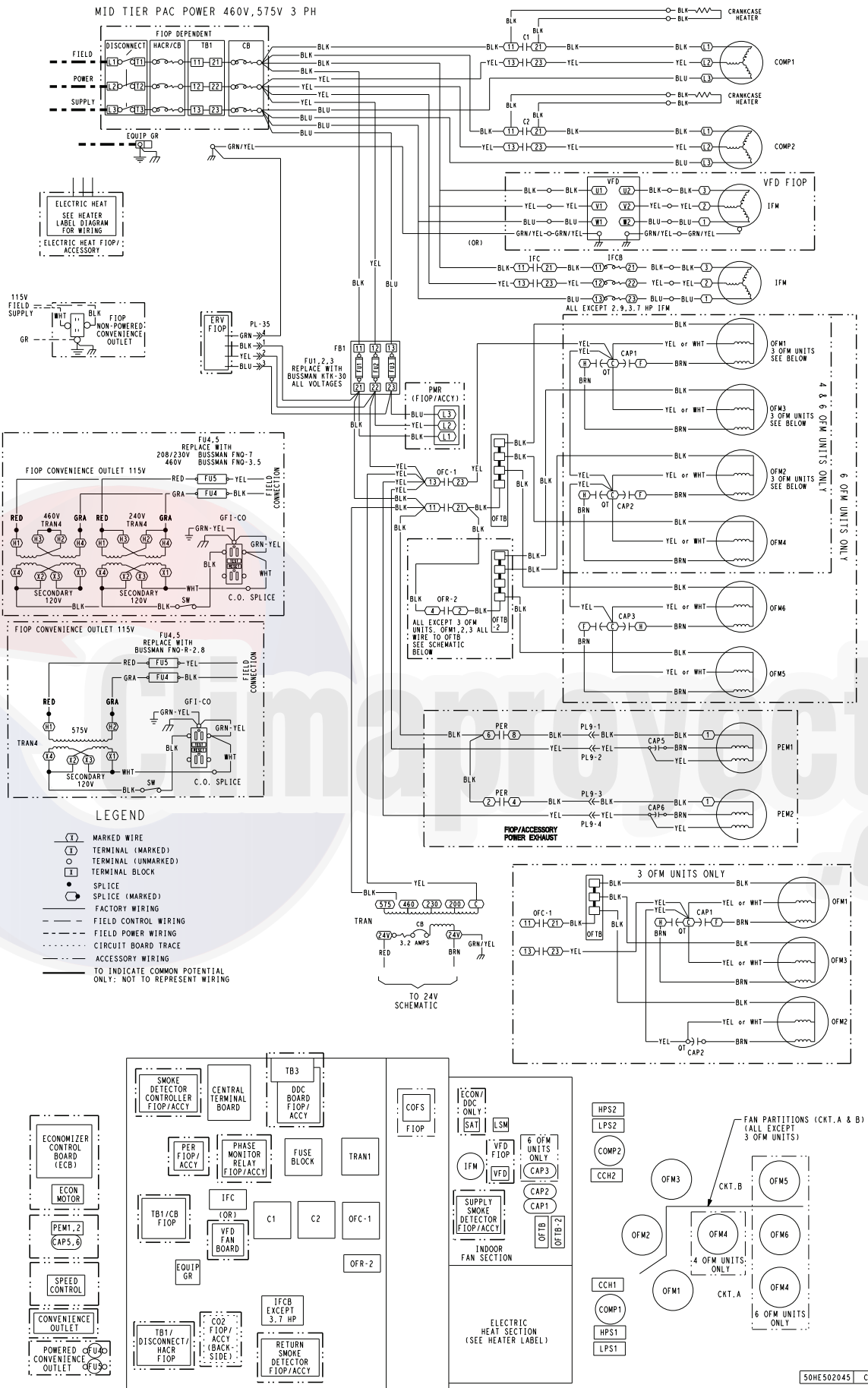

Fig. 72 — 50HC D17-D28 Power Diagram (460/575-3-60)

MID TIER 6 OFM PAC POWER 208/230V 3 PH

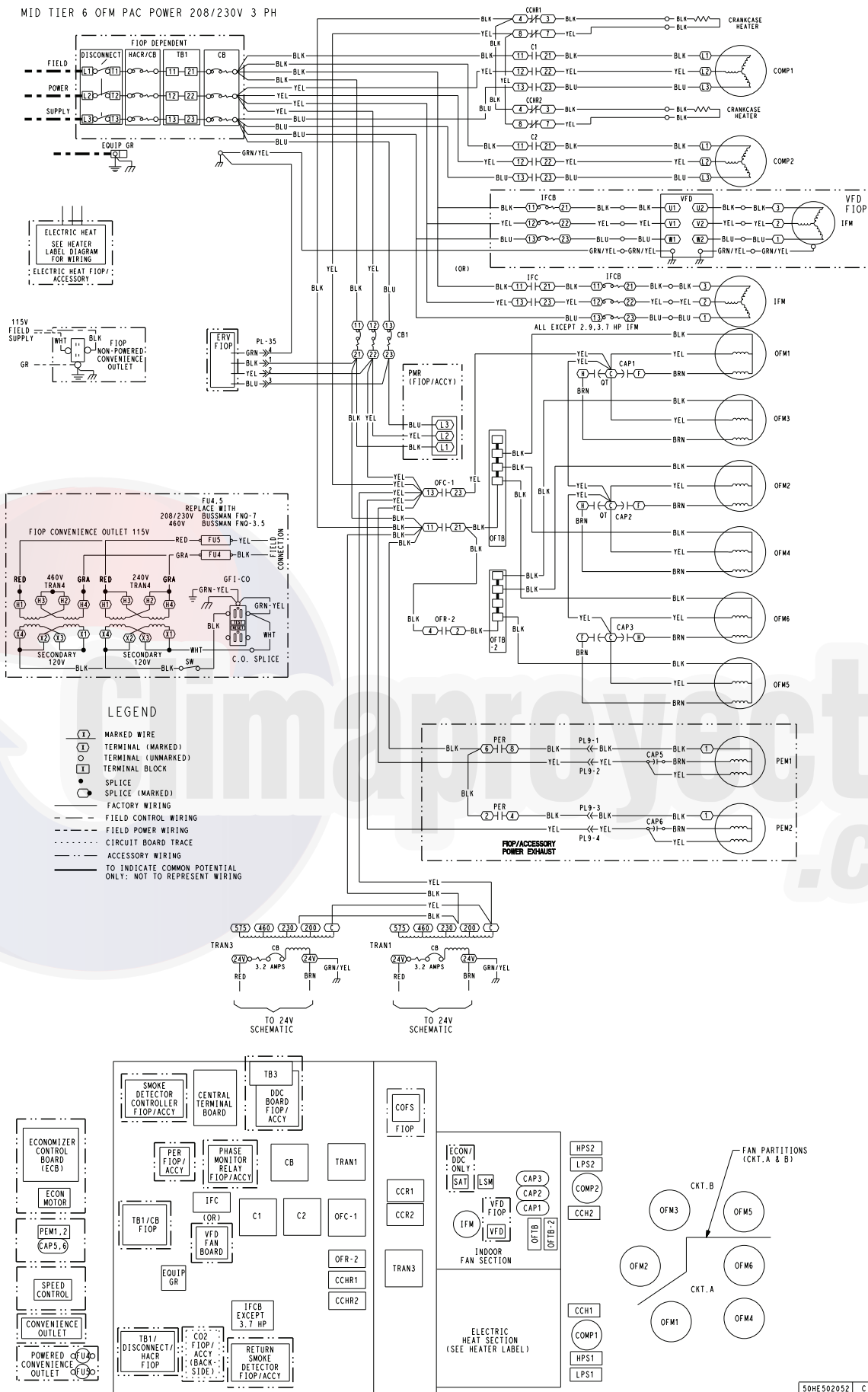

Fig. 73 — 50HC D28 Power Diagram (208/230-3-60)

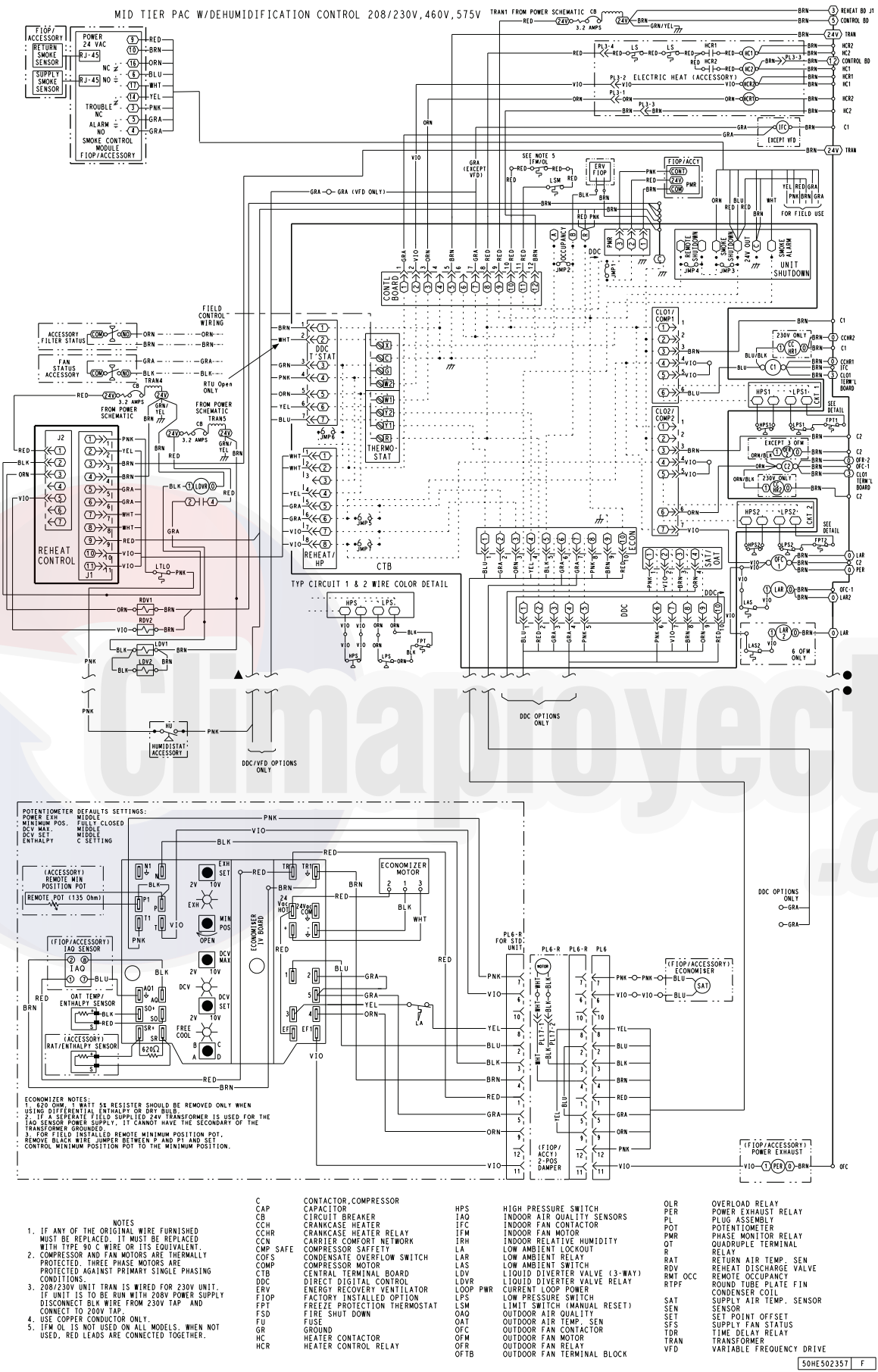

Fig. 74 — 50HC Control Diagram with Humidi-MiZer® System – D17-D24 (208/230-3-60, 460/575-3-60), D28 (460/575-3-60)

MID TIER
486 OFM PAC W/DEHUMIDIFICATION
CONTROL 208/230V

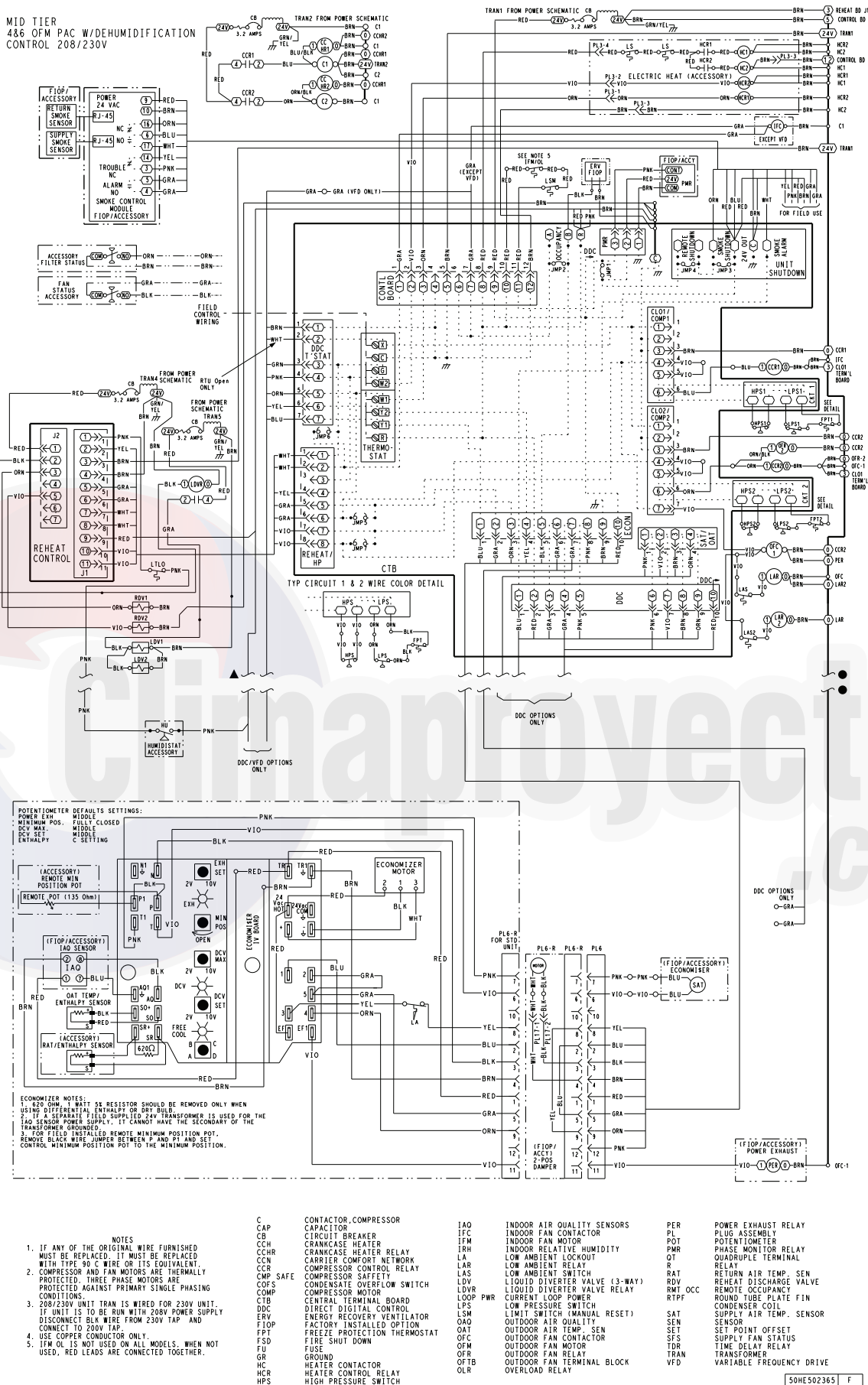

Fig. 75 — 50HC D28 Control Diagram with Humidi-MiZer® System (208/230-3-60)

MID TIER PAC W/DEHUMIDIFICATION POWER 208/230V 3 PH

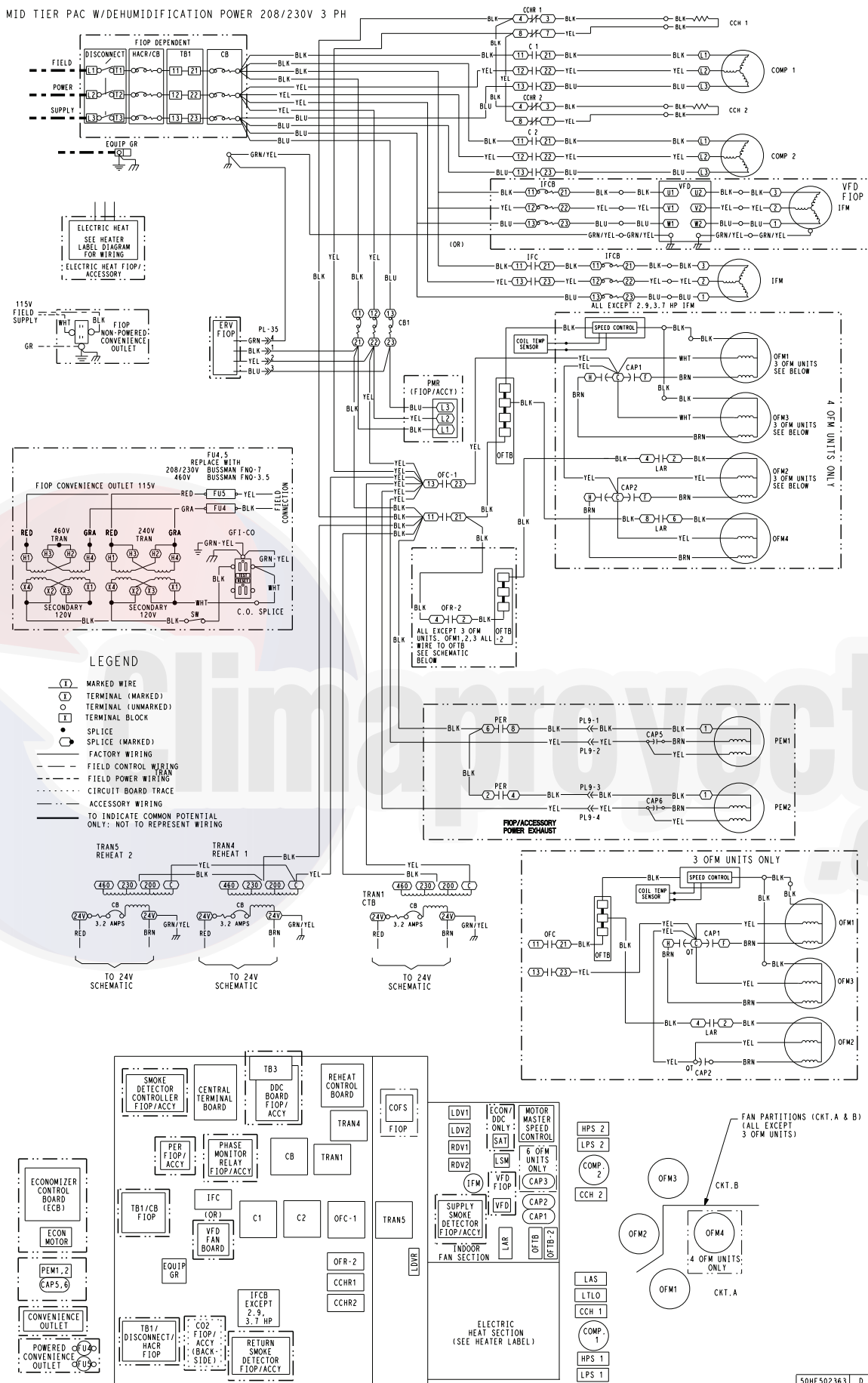

Fig. 76 — 50HC D17-D24 Power Diagram with Humidi-MiZer® System (208/230-3-60)

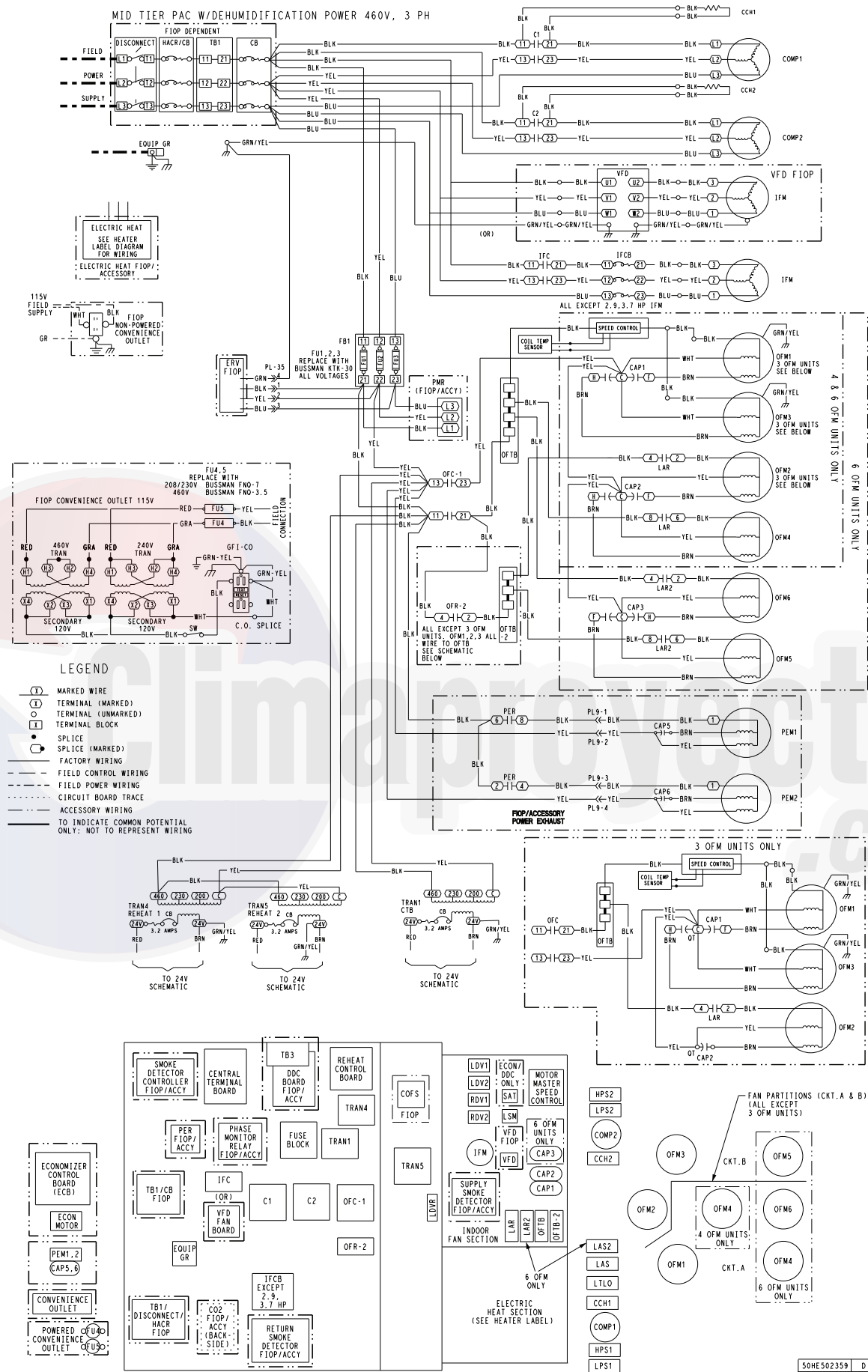

Fig. 77 — 50HC D17-D28 Power Diagram with Humidi-MiZer® System (460-3-60)

MID TIER PAC W/DEHUMIDIFICATION POWER 575V 3 PH

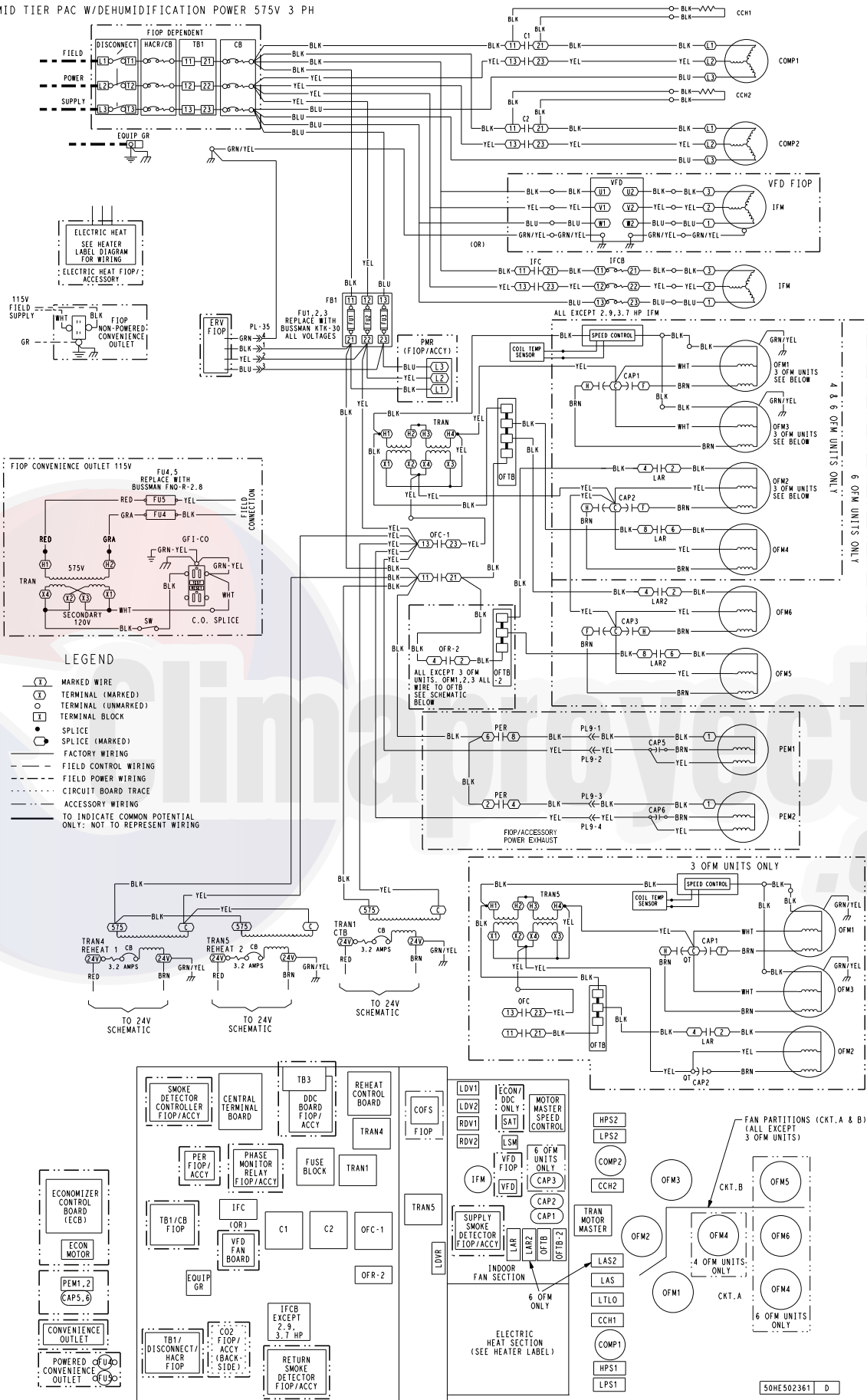

Fig. 78 — 50HC D17-D28 Power Diagram with Humidi-MiZer® System (575-3-60)

MID TIER 486 OFM PAC W/DEHUMIDIFICATION POWER 208/230V 3 PH

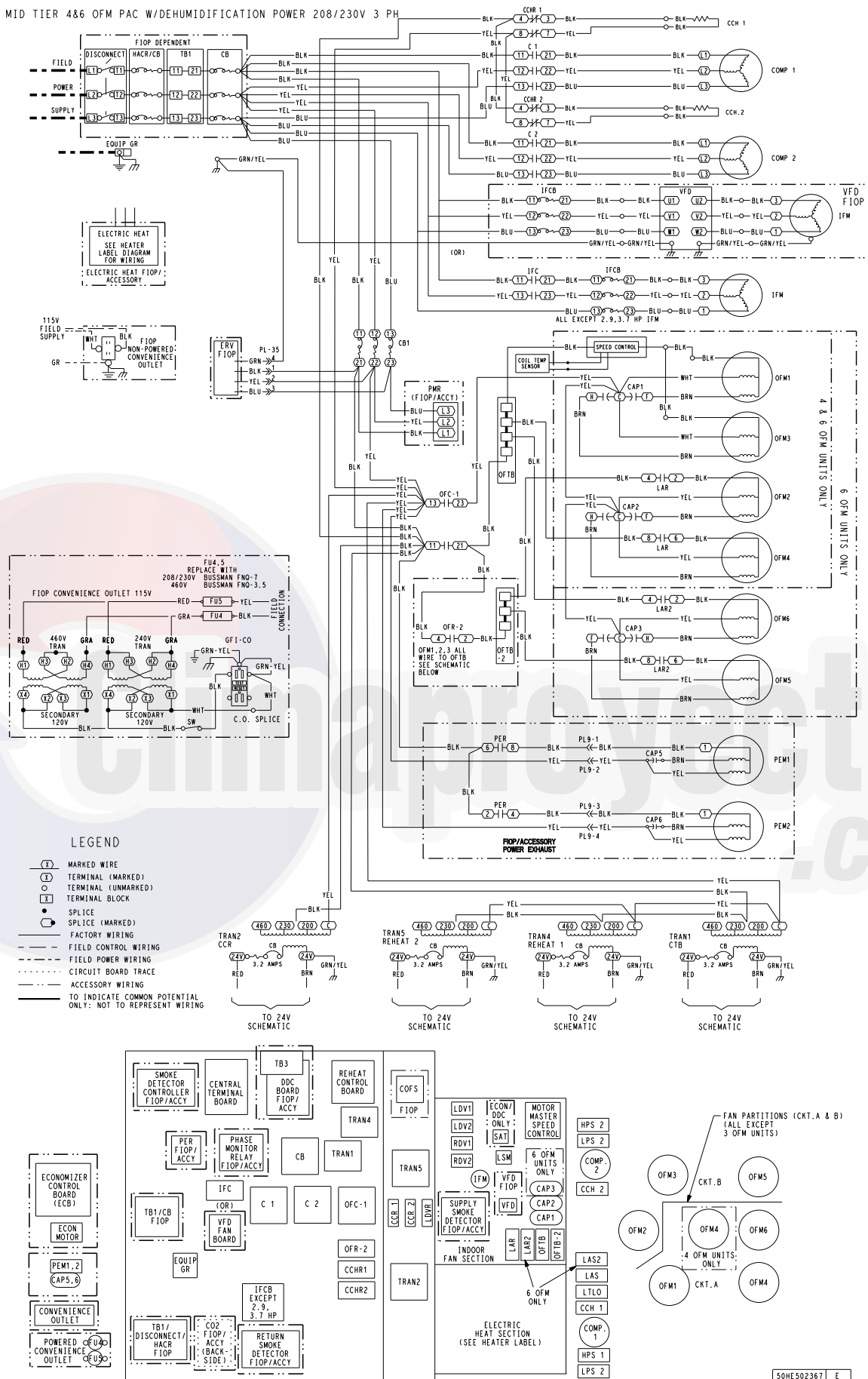

Fig. 79 — 50HC D28 Power Diagram with Humidi-MiZer® System (208/230-3-60)

Smoke Detectors

Smoke detectors are available as factory-installed options on 50HC models. Smoke detectors may be specified for supply air only, for return air without or with economizer, or in combination of supply air and return air. Return-air smoke detectors are arranged for vertical return configurations only. The unit is factory-configured for immediate smoke detector shutdown operation; additional wiring or modifications to unit terminal board may be necessary to complete the unit and smoke detector configuration to meet project requirements.

RETURN AIR SENSOR TUBE INSTALLATION

The return air sampling tube is shipped in the unit's supply fan section, attached to the blower housing (see Fig. 81). Its operating location is in the return air section of the unit (see Fig. 82, unit without economizer, or Fig. 83, unit with economizer), inserted into the return air sensor module housing which protrudes through the back of the control box.

To install the return air sensor sampling tube:

1. Remove the tube from its shipping location.
2. Open the unit end to access the return air sensor (located on right-hand partition).
3. Orient the tube's sampling holes into the return air flow direction. For vertical application, position the sampling holes on the bottom of the tube, facing into the bottom return duct opening. For horizontal application, position the sampling holes on the side of the tube, facing the unit's end panel.
4. Insert the sampling tube into the return air sensor module until the tube snaps into position.
5. Replace end panel or outside air hood.

SMOKE DETECTOR TEST MAGNET

Locate the magnet; it is shipped in the control box area.

ADDITIONAL APPLICATION DATA

Refer to the *Factory-Installed Smoke Detectors for Small and Medium Rooftop Units 2 to 25 Tons* application data for discussions on additional control features of these smoke detectors including multiple unit coordination.

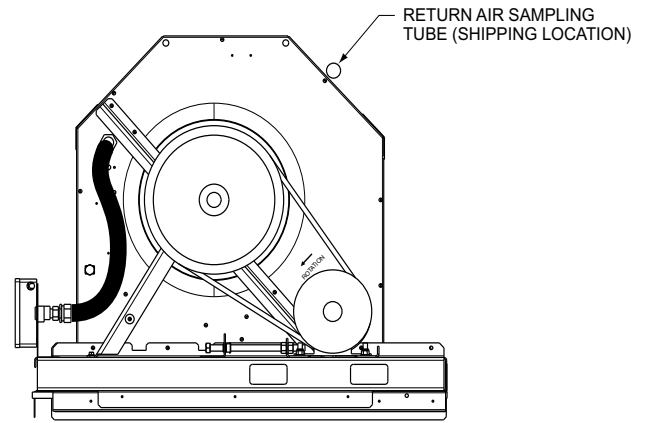

Fig. 81 — Typical Supply Air Smoke Detector Sensor Location

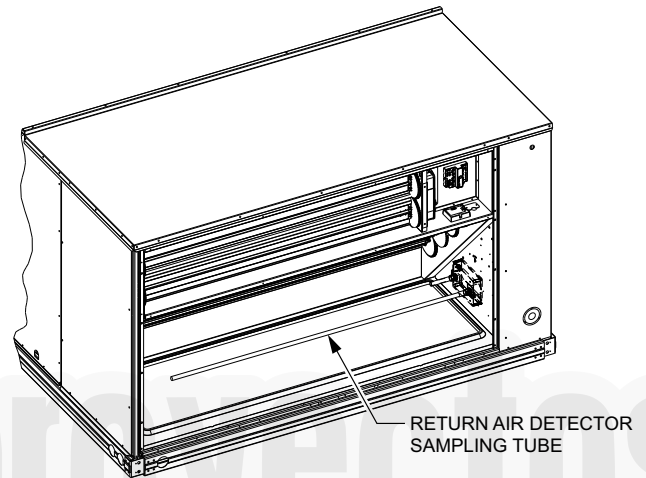

Fig. 82 — Return Air Sampling Tube Location in Unit without Economizer

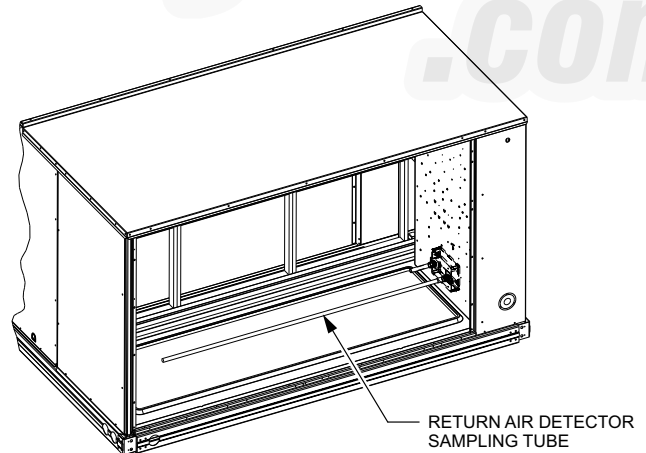

Fig. 83 — Return Air Sampling Tube Location in Unit with Economizer

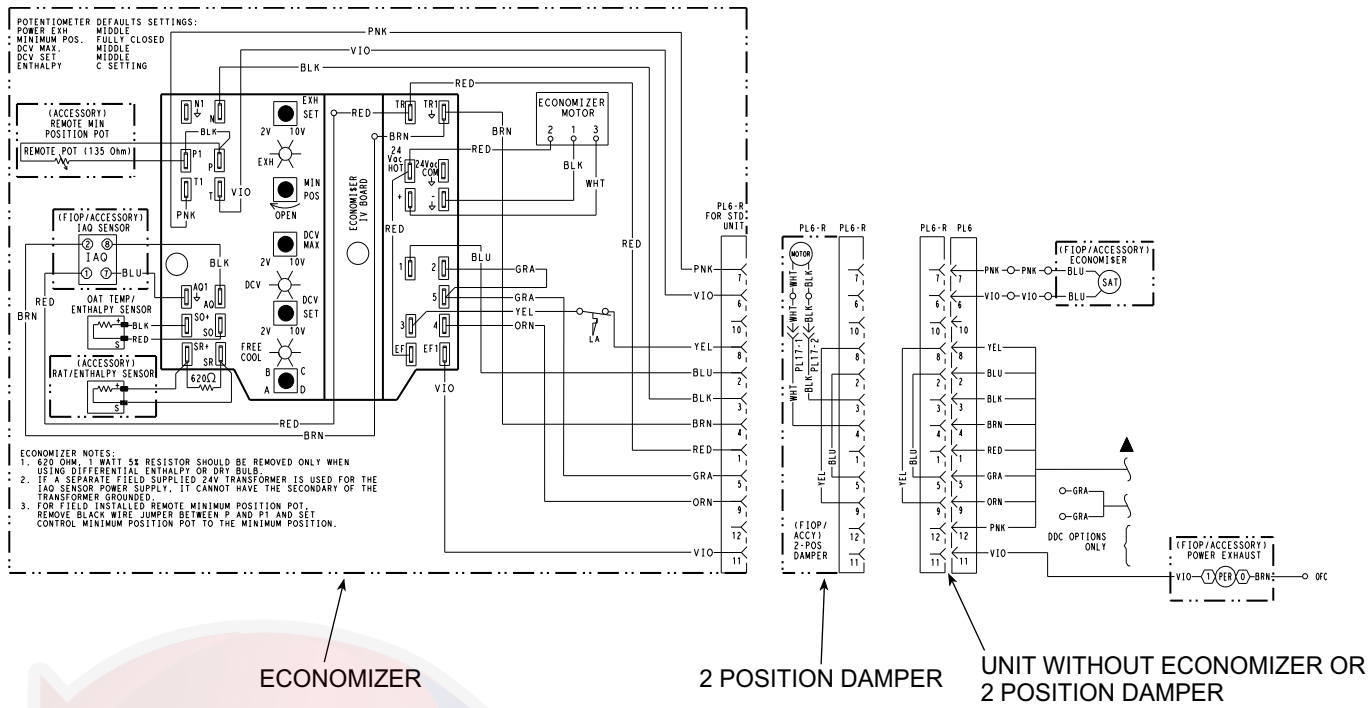

Fig. 84 — EconoMiSer® IV Wiring

Step 12 — Adjust Factory-Installed Options

ECONOMISER IV OCCUPANCY SWITCH

Refer to Fig. 84 for general EconoMiSer IV wiring. External occupancy control is managed through a connection on the Central Terminal Board.

If external occupancy control is desired, connect a time clock or remotely controlled switch (closed for Occupied, open for Unoccupied sequence) at terminals marked OCCUPANCY on CTB. Remove or cut jumper JMP 2 to complete the installation.

Step 13 — Install Accessories

Available accessories include:

- Roof Curb
- Thru-base connection kit (must be installed before unit is set on curb)
- Manual outside air damper
- Two-Position motorized outside air damper
- EconoMiSer® IV (with control and integrated barometric relief)
- EconoMiSer 2 (without control/for external signal and integrated barometric relief)
- Power Exhaust
- Differential dry-bulb sensor (EconoMiSer IV)
- Outdoor enthalpy sensor
- Differential enthalpy sensor
- Electric Heaters
- Single Point Kits
- Low Ambient Controls
- Thermostat/Sensors
- CO₂ sensor
- DDC interface (PremierLink controller)
- Louvered hail guard
- Phase monitor control
- Winter Start kit

Refer to separate installation instructions for information on installing these accessories.

Step 14 — Check Belt Tension

Measure the belt span length as shown in Fig. 85. Calculate the required deflection by multiplying the belt span length by 1/64. For example, if the belt span length is 32 inches:
 $32 \times \frac{1}{64} = \frac{1}{2}$ -in. deflection.

BELT FORCE — DEFLECTION METHOD

Check the belt tension with a spring-force belt force deflection gage (available from drive belt manufacturer).

1. Place a straightedge along the belt between the two pulleys. Measure the distance between the motor shaft and the blower shaft.
2. Set the tension gage to the desired tension (see Table 1 in Fig. 85). Place the large O-ring at that point.
3. Press the tension checker downward on the belt until the large O-ring is at the bottom of the straightedge.
4. Adjust the belt tension as needed.

Adjust belt tension by loosening the motor mounting plate front bolts and rear bolt (see Fig. 86) and slide the plate towards the fan (to reduce tension) or away from the fan (to increase tension). Ensure the blower shaft and motor shaft are parallel to each other (pulleys aligned). Tighten all bolts securely when finished.

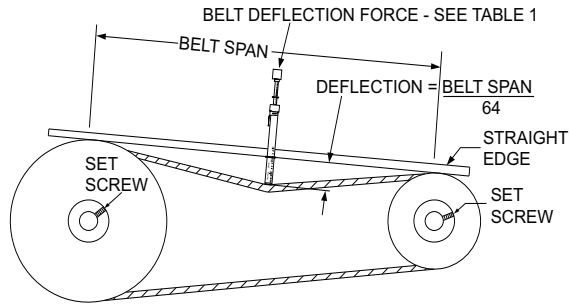

TORQUE ALL SHEAVE SET SCREWS TO 110-130 in. lbs

| BELT CROSS SECTION | SMALLEST SHEAVE DIAMETER | BELT DEFLECTION FORCE (LBS) | | | |
|--------------------|--------------------------|-----------------------------|-----|---------------|------|
| | | UNNOTCHED BELTS | | NOTCHED BELTS | |
| | | USED | NEW | USED | NEW |
| A, AX | 3.0-3.6 | 3.7 | 5.5 | 4.1 | 6.1 |
| | 3.8-4.8 | 4.5 | 6.8 | 5.0 | 7.4 |
| | 5.0-7.0 | 5.4 | 8.0 | 5.7 | 8.4 |
| B, BX | 3.4-4.2 | — | — | 4.9 | 7.2 |
| | 4.4-5.6 | 5.3 | 7.9 | 7.1 | 10.5 |
| | 5.8-8.6 | 6.3 | 9.4 | 8.5 | 12.6 |

Table 1

| BELT CONDITION | TENSION FORCE IN BELT (LBS) |
|----------------|-----------------------------|
| New | 100 |
| Used | 80 |

Table 2

Fig. 85 — V-Belt Force Label

BELT TENSION METHOD

Requires belt tension gage that measures tension in belt in units of lbs force.

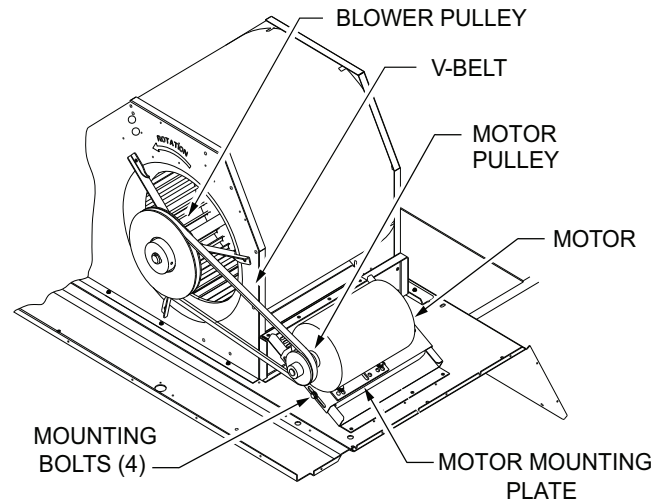

Fig. 86 — Belt Drive Motor Mounting

Pre-Start and Start-Up

This completes the mechanical installation of the unit. Refer to the unit's Service and Maintenance manual for detailed Pre-Start and Start-Up instructions.



START-UP CHECKLIST
(Remove and use for job file)

NOTE: To avoid injury to personnel and damage to equipment or property when completing the procedures listed in this start-up checklist, use good judgment, follow safe practices, and adhere to the safety considerations/information as outlined in preceding sections of this Installation Instructions document.

I. PRELIMINARY INFORMATION

MODEL NO. _____
JOB NAME _____
SERIAL NO. _____
ADDRESS _____
START-UP DATE _____
TECHNICIAN NAME _____
ADDITIONAL ACCESSORIES _____

II. PRE-START-UP

Verify that job site voltage agrees with voltage listed on rating plate (Y/N) _____
Verify that all packaging materials have been removed from unit (Y/N) _____
Remove all shipping hold down bolts and brackets per installation instructions (Y/N) _____
Verify that condensate connection is installed per installation instructions (Y/N) _____
Check refrigerant piping for indications of leaks; investigate and repair if necessary (Y/N) _____
Check all electrical connections and terminals for tightness (Y/N) _____
Check that return (indoor) air filters are clean and in place (Y/N) _____
Verify that unit installation is level (Y/N) _____
Check fan wheels and propeller for location in housing/orifice and setscrew tightness (Y/N) _____
Check to ensure that electrical wiring is not in contact with refrigerant lines or sharp metal edges (Y/N) _____
Check pulley alignment and belt tension per installation instructions (Y/N) _____

III. START-UP (Refer to Unit Service/Maintenance Manual for Start-Up Instructions)

ELECTRICAL

| | | | |
|-------------------|-------------|-------------|-------------|
| Supply Voltage | L1-L2 _____ | L2-L3 _____ | L3-L1 _____ |
| Compressor Amps 1 | L1 _____ | L2 _____ | L3 _____ |
| Compressor Amps 2 | L1 _____ | L2 _____ | L3 _____ |
| Indoor Fan Amps | L1 _____ | L2 _____ | L3 _____ |
| Outdoor Fan Amps | NO.1 _____ | NO.2 _____ | NO.3 _____ |
| | NO.4 _____ | NO.5 _____ | NO.6 _____ |

TEMPERATURES

| | | |
|--------------------------------|------------------------|------------------------|
| Outdoor-air Temperature | _____ °F DB (Dry Bulb) | _____ °F WB (Wet Bulb) |
| Return-air Temperature | _____ °F DB | _____ °F WB |
| Cooling Supply Air Temperature | _____ °F DB | _____ °F WB |

