

50KCQ
Packaged Heat Pump
14 SEER
3 to 5 Nominal Tons

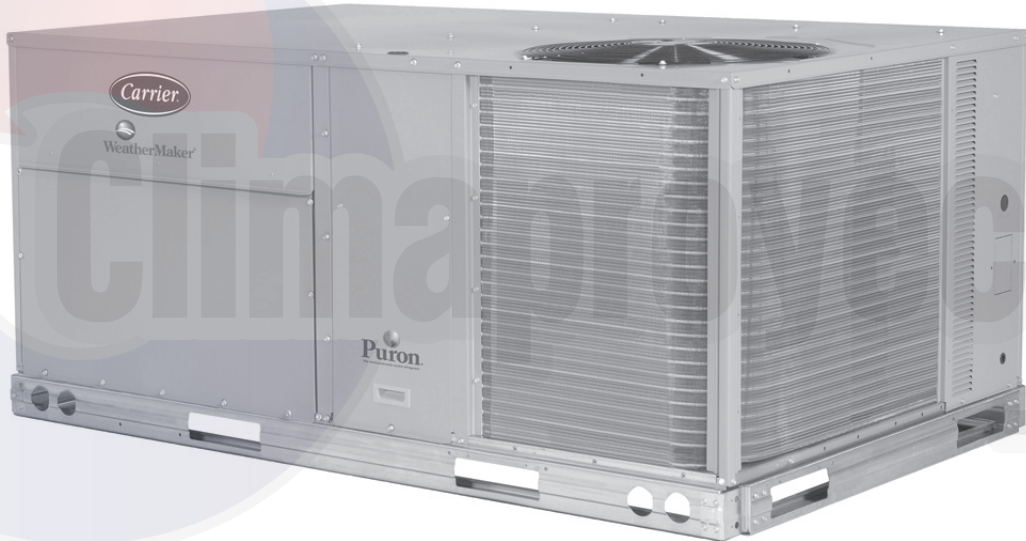

Product Data



C08613



TABLE OF CONTENTS

	PAGE		PAGE
FEATURES AND BENEFITS	3	COOLING TABLES	32
MODEL NUMBER NOMENCLATURE	4	STATIC PRESSURE TABLES	28
FACTORY OPTIONS & ACCESSORIES	5	FAN PERFORMANCE	28
AHRI CAPACITY RATING	8	ELECTRICAL INFORMATION	36
SOUND PERFORMANCE	9	MCA / MOCP	38
PHYSICAL DATA	10	SEQUENCE OF OPERATION	44
WEIGHTS & DIMENSIONS	17	GUIDE SPECIFICATIONS	47
APPLICATION DATA	22		

50KCQ



Turn to the Experts™

Your Carrier Packaged Heat Pump rooftop unit (RTU) was designed by customers for customers. With no-strip screw collars, handled access panels, and more we've made your unit easy to install, easy to maintain and easy to use.

Easy to install:

All WeatherMaker™ units are field-convertible to horizontal air flow which makes it easy to adjust to unexpected job site complications. Lighter units make easy replacement. Carrier 50KCQ rooftops fit on existing Carrier curbs dating back to 1989. Also, our large control box gives you room to work and room to mount Carrier accessory controls.

Easy to maintain:

Easy access handles by Carrier provide quick and easy access to all normally serviced components. Our “no-strip” screw system has superior holding power and guides screws into position while preventing the screw from stripping the unit’s metal. Take accurate pressure readings by reading condenser pressure with panels on. Simply remove the black, composite plug, route your gauge line(s) through the hole, and connect them to the refrigeration service valve(s). Now, you can take refrigeration system pressure readings without affecting the condenser airflow.

Easy to use:

The newly designed, central terminal board by Carrier puts all your connections and troubleshooting points in one convenient place, standard. Most low voltage connections are made to the same board and make it easy to find what you’re looking for and easy to access it. Carrier rooftops have high and low pressure switches, a filter drier, and 2-in. (51mm) filters standard.

FEATURES AND BENEFITS

- SEER up to 14.3
- EER up to 12.2.
- HSPF's up to 8.2
- Up to 28% lighter than similar industry units. Lighter rooftops make easier replacement jobs.
- 3 - 5 ton units fit on existing Carrier rooftop curbs making the utility connections the same. This saves time and money on replacement jobs.
- Standardized components and layout. Standardized components and controls make service and stocking parts easier.
- Scroll compressors on all units. This makes service, stocking parts, replacement, and trouble-shooting easier.
- Crankcase heater on all models (except 04 size) provides added protection in all applications.
- Precision-sized suction line accumulator provides high reliability by preventing liquid from entering the compressor during low ambient conditions and reverse cycle switch over.
- Field convertible from vertical to horizontal airflow configuration on all models. No special kit required.
- 4-way reversing valve rapidly changes the flow of refrigerant to quickly changeover from cooling to heating and heating to cooling.
- Easy-adjust, belt drive motor available on all sizes. There's no need for field-supplied drives or motors.
- Standard Direct Drive - ECM indoor motor with optional belt drive system to meet nearly all applications.
- Provisions for bottom or side condensate drain.
- Capable of thru-the-base or thru-the-curb electrical routing.
- Dependable time/temperature defrost logic provides a defrost cycle, if needed, every 30, 60, 90 or 120 minutes and is adjustable.
- Single-point electrical connection.
- Sloped, composite drain pan sheds water; and won't rust.
- Standardized controls and control box layout. Standardized components and controls make stocking parts and service easier.
- Clean, large, easy to use control box.
- Standard coils are copper round tube, aluminum plate fin with optional coil coatings and copper fin design.
- Color-coded wiring.
- Large, laminated wiring and power wiring drawings which are affixed to unit make troubleshooting easy.
- Single, central terminal board for test and wiring connections.
- Fast-access, handled, panels for easy access to the blower and blower motor, control box, and compressors.
- "No-strip" screw system guides screws into the panel and captures them tightly without stripping the screw, the panel, or the unit.
- Exclusive, newly-designed indoor refrigerant header for easier maintenance and replacement.
- Mechanical cooling (115°F to 25°F or 46°C to -4°C) on Electro-Mechanical (E/M) and Direct Digital Controller (DDC) (PremierLink™ or RTU Open controller).
- 2-in. (51mm) disposable filters on all units.
- High capacity refrigerant filter drier on each circuit.
- High pressure switch, loss of charge switch and freeze protection adds greater unit reliability.

MODEL NUMBER NOMENCLATURE

Position:	1	2	3	4	5	6	7	8	9	10	11	12	13	14	15	16	17	18
Example:	5	0	K	C	Q	A	0	6	A	0	A	6	-	0	B	2	A	0

50KCQ

Unit/Series/Model
50KCQ - Packaged Rooftop Heat Pump

Refrig. Systems Options
A = One Stage Cooling Models

Cooling Tons
04 - 3 ton
05 - 4 ton
06 - 5 ton

Sensor Options
A = None
B = RA Smoke Detector
C = SA Smoke Detector
D = RA + SA Smoke Detector
E = CO₂
F = RA Smoke Detector and CO₂
G = SA Smoke Detector and CO₂
H = RA + SA Smoke Detector and CO₂

Indoor Fan Options
0 = Direct Drive ECM
2 = Medium Static Option – Belt Drive
3 = High Static Option – Belt Drive

Coil Options (Outdoor - Indoor - Hail Guard)
A = Al/Cu - Al/Cu
B = Precoat Al/Cu - Al/Cu
C = E-coat Al/Cu - Al/Cu
D = E-coat Al/Cu - E-coat Al/Cu
E = Cu/Cu - Al/Cu
F = Cu/Cu - Cu/Cu
M = Al/Cu -Al/Cu — Louvered Hail Guard
N = Precoat Al/Cu - Al/Cu — Louvered Hail Guard
P = E-coat Al/Cu - Al/Cu — Louvered Hail Guard
Q = E-coat Al/Cu - E-coat Al/Cu — Louvered Hail Guard
R = Cu/Cu - Al/Cu — Louvered Hail Guard
S = Cu/Cu - Cu/Cu — Louvered Hail Guard

Note: On single phase (-3 voltage code) models, the following are not available as a factory installed option:

- Coated Coils or Cu Fin Coils
- Louvered Hail Guards
- Economizer or 2 Position Damper
- Powered 115 Volt Convenience Outlet

Factory Assigned
0 = Standard
1 = LTL

Electrical Options
A = None
C = Non-Fused Disconnect
D = Thru-The-Base Connections
F = Non-Fused Disconnect and Thru-The-Base Connections

Service Options
0 = None
1 = Unpowered Convenience Outlet
2 = Powered Convenience Outlet
3 = Hinged Panels
4 = Hinged Panels and Unpowered Convenience Outlet
5 = Hinged Panels and Powered Convenience Outlet

Intake / Exhaust Options
A = None
B = Temperature Economizer w/ Barometric Relief
F = Enthalpy Economizer w/ Barometric Relief
K = 2-Position Damper
U = Temperature Ultra Low Leak Economizer w/ Barometric Relief
W= Enthalpy Ultra Low Leak Economizer w/ Barometric Relief

Base Unit Controls
0 = Electro-mechanical Controls can be used with W7212 EconoMi\$er IV (Non-Fault Detection and Diagnostic)
1 = PremierLink Controller
2 = RTU Open Multi-Protocol Controller
6 = Electro-mechanical with W7220 Economizer controller Controls. Can be used with W7220 EconoMi\$er X (with Fault Detection and Diagnostic)

Design Revision
- = Factory Design Revision

Voltage
1 = 575/3/60
3 = 208-230/1/60
5 = 208-230/3/60
6 = 460/3/60

FACTORY OPTIONS AND/OR ACCESSORIES

Table 1 – FACTORY-INSTALLED OPTIONS AND FIELD-INSTALLED ACCESSORIES

CATEGORY	ITEM	FACTORY INSTALLED OPTION	FIELD INSTALLED ACCESSORY
Cabinet	Thru-the-base electrical connections	X	X
	Hinged Access Panels	X	
Coil Options	Cu/Cu indoor and/or outdoor coils ⁵	X	
	Pre-coated outdoor coils ⁵	X	
	Premium, E-coated outdoor coils ⁵	X	
Condenser Protection	Condenser coil hail guard (louvered design) ⁵	X	X
Controls	Thermostats, temperature sensors, and subbases		X
	PremierLink DDC communicating controller	X	X
	RTU Open –protocol controller	X	
	Smoke detector (supply and/or return air)	X	
	Time Guard II compressor delay control circuit		X
	Phase Monitor		X
Economizers & Outdoor Air Dampers	EconoMi\$er IV (for electro-mechanical controlled – Non FDD (Standard air leak damper models) ^{5, 6}	X	X
	EconoMi\$er2 for DDC controls, complies with FDD (Standard and Ultra Low Leak air damper models) ^{5, 7}	X	X
	Motorized 2 position outdoor-air damper ⁵	X	X
	Manual outdoor-air damper (25% and 50%)		X
	Barometric relief ¹	X	X
	Power exhaust		X
	EconoMi\$er X for electro-mechanical controls, complies with FDD (Standard and Ultra Low Leak air damper models) ^{5, 6}	X	X
Economizer Sensors & IAQ Devices	Single dry bulb temperature sensors ²	X	X
	Differential dry bulb temperature sensors ²		X
	Single enthalpy sensors ²	X	X
	Differential enthalpy sensors ²		X
	CO ₂ sensor (wall, duct, or unit mounted) ²	X	X
Electric Heat	Electric Resistance Heaters		X
	Single Point Kit		X
Indoor Motor & Drive	Multiple motor and drive packages	X	
Low Ambient Control	Winter start kit ³		X
	Motormaster® head pressure controller ³		X
Power Options	Convenience outlet (powered) ⁵	X	
	Convenience outlet (unpowered)	X	
	Non-fused disconnect ⁴	X	
Roof Curbs	Roof curb 14-in (356mm)		X
	Roof curb 24-in (610mm)		X

NOTES:

1. Included with economizer.
2. Sensors for optimizing economizer.
3. See application data for assistance.
4. Available on units with MOCP's of 80 amps or less.
5. Not available as factory installed option on single phase (208/230/1/60) models. Use field-installed accessory where available.
6. FDD – (Fault Detection and Diagnostic) capability per California Title 24 section 120.2
7. Models with RTU Open DDC controls comply with California Title 24 Fault Detection and Diagnostic (FDD). PremierLink is non FDD.

50KCG

FACTORY OPTIONS AND/OR ACCESSORIES (cont.)

Economizer (dry bulb or enthalpy)

Economizers save money. They bring in fresh, outside air for ventilation; and provide cool, outside air to cool your building. This is the preferred method of low ambient cooling. When coupled to CO₂ sensors, Economizers can provide even more savings by coupling the ventilation air to only that amount required.

Economizers are available, installed and tested by the factory, with either enthalpy or dry bulb temperature inputs. There are also models for electromechanical as well as direct digital controllers. Additional sensors are available as accessories to optimize the economizers.

Economizers include gravity controlled, barometric relief which equalizes building pressure and ambient air pressures. This can be a cost effective solution to prevent building pressurization.

CO₂ Sensor

Improves productivity and saves money by working with the economizer to intake only the correct amount of outside air for ventilation. As occupants fill your building, the CO₂ sensor detects their presence through increasing CO₂ levels, and opens the economizer appropriately.

When the occupants leave, the CO₂ levels decrease, and the sensor appropriately closes the economizer. This intelligent control of the ventilation air, called Demand Control Ventilation (DCV) reduces the overall load on the rooftop, saving money.

Smoke Detectors

Trust the experts. Smoke detectors make your application safer and your job easier. Carrier smoke detectors immediately shut down the rooftop unit when smoke is detected. They are available, installed by the factory, for supply air, return air, or both.

Louvered Hail Guards

Sleek, louvered panels protect the condenser coil from hail damage, foreign objects, and incidental contact.

Convenience Outlet (powered or un-powered)

Lower service bills by including a convenience outlet in your specification. Carrier will install this service feature at our factory, powered. Provides a convenient, 15 amp, 115V GFCI receptacle.

Non-fused Disconnect

This OSHA-compliant, factory-installed, safety switch allows a service technician to locally secure power to the rooftop.

Power Exhaust Pressure Relief

Superior internal building pressure control. This field-installed accessory may eliminate the need for costly, external pressure control fans.

PremierLink™

This CCN controller regulates your rooftop's performance to tighter tolerances and expanded limits, as well as facilitates zoning systems and digital accessories. It also unites your Carrier HVAC equipment together on one, coherent CCN network. The PremierLink can be factory-installed, or easily field-installed.

RTU Open, Multi-protocol Controller

Connect the rooftop to an existing BAS without needing complicated translators or adapter modules using the RTU Open controller. This new controller speaks the 4 most common building automation system languages (Bacnet, Modbus, N2, and Lonworks). Use this controller when you have an existing BAS.

Time Guard II Control Circuit

This accessory protects your compressor by preventing short-cycling in the event of some other failure, prevents the compressor from restarting for 30 seconds after stopping. Not required with PremierLink®, RTU Open, or authorized commercial thermostats.

Filter or Fan Status Switches

Use these differential pressure switches to detect a filter clog or indoor fan motor failure. When used in conjunction with a compatible unit controller/thermostat, the switches will activate an alarm to warn the appropriate personnel.

Motorized 2-Position Damper

The new Carrier 2-position, motorized outdoor air damper admits up to 100% outside air. Using reliable, gear-driven technology, the 2-position damper opens to allow ventilation air and closes when the rooftop stops, stopping unwanted infiltration.

Manual OA Damper

Manual outdoor air dampers are an economical way to bring in ventilation air. The dampers are available in 25% and 50% versions.

Motormaster Head Pressure Controller

The Motormaster motor controller is a low ambient, head pressure controller kit that is designed to maintain the unit's condenser head pressure during periods of low ambient cooling operation. This device should be used as an alternative to economizer free cooling not when economizer usage is either not appropriate or desired. The Motormaster will either cycle the outdoor fan motors or operate them at reduced speed to maintain the unit operation, depending on the model.

FACTORY OPTIONS AND/OR ACCESSORIES (cont.)

Alternate Motors and Drives

Some applications need larger horsepower motors, some need more airflow, and some need both. Regardless of the case, your Carrier expert has a factory installed combination to meet your application. A wide selection of motors and pulleys (drives) are available, factory installed, to handle nearly any application.

Thru-the-Base Connections

Thru-the-base connections, available as either an accessory or as a factory option, are necessary to ensure proper connection and seal when routing wire and piping through the rooftop's basepan and curb. These couplings eliminate roof penetration and should be considered for gas lines, main power lines, as well as control power.

Electric Heaters

Carrier offers a full line of field-installed accessory heaters. The heaters are very easy to use and install. All are pre-engineered and certified.

Thru-the-Base Connections

Thru-the-base connections, available as either an accessory or as a factory option, are necessary to ensure proper connection and seal when routing wire and piping through the rooftop's basepan and curb. These couplings eliminate roof penetration and should be considered for gas lines, main power lines, as well as control power.

50KCG



Table 2 – AHRI COOLING RATING TABLES

COOLING MODE						
50KCQ	COOLING STAGES	NOMINAL CAPACITY (TONS)	NET COOLING CAPACITY (BTUH)	TOTAL POWER (kW)	SEER	EER
A04	1	3	35,600	2.9	14.00	12.10
A05	1	4	49,000	4.0	14.00	12.10
A06	1	5	58,000	4.7	14.30	12.20

HEATING MODE			
50KCQ	HSPF	HEATING, LOW AT 17°F (-8°C) AMBIENT	HEATING, HIGH AT 47°F (8°C) AMBIENT
		CAPACITY (BTUH)	CAPACITY (BTUH)
A04	8.10	18,400	35,600
A05	8.00	23,800	45,500
A06	8.20	28,600	58,000

50KCQ

LEGEND

- AHRI – Air Conditioning, Heating and Refrigeration Institute
- ASHRAE – American Society of Heating, Refrigerating and Air Conditioning, Inc.
- EER – Energy Efficiency Ratio
- HSPF – Heating Seasonal Performance Factor
- SEER – Seasonal Energy Efficiency Ratio

NOTES:

1. Rated and certified under AHRI Standard 210/240.
2. Ratings are based on:
Cooling Standard: 80°F (27°C) db, 67°F (19°C) wb indoor air temp and 95°F db outdoor air temp.
3. All 50KCQ units comply with ASHRAE 90.1 Energy Standard for minimum SEER and EER requirements.



Use of the AHRI Certified TM Mark indicates a manufacturer's participation in the program. For verification of certification for individual products, go to www.ahridirectory.org.



Table 3 – MINIMUM - MAXIMUM AIRFLOWS ELECTRIC HEAT

UNIT	COOLING		ELECTRIC HEATERS	
	MINIMUM	MAXIMUM	MINIMUM	MAXIMUM
50KCQ*04	900	1500	900	1500
50KCQ*05	1200	2000	1200	2000
50KCQ*06	1500	2500	1500	2500

Table 4 – SOUND PERFORMANCE TABLE

50KCQ	OUTDOOR SOUND (dB)								
	A-WEIGHTED	63	125	250	500	1000	2000	4000	8000
A04	77	78.9	81.7	74.9	72.5	70.3	65.6	65.6	62.6
A05	80	90.4	84.6	77.6	77.5	74.8	70.6	68.0	64.2
A06	80	92.7	84.9	79.0	76.7	73.8	69.6	66.4	62.8

LEGEND
dB – Decibel

NOTES:

1. Outdoor sound data is measured in accordance with AHRI standard 270.
2. Measurements are expressed in terms of sound power. Do not compare these values to sound pressure values because sound pressure accounts for specific environmental factors which do not match individual applications. Sound power values are independent of the environment and therefore more accurate.
3. A-weighted sound ratings filter out very high and very low frequencies, to better approximate the response of an "average" human ear. A-weighted measurements for Carrier units are taken in accordance with 270.

50KCQ

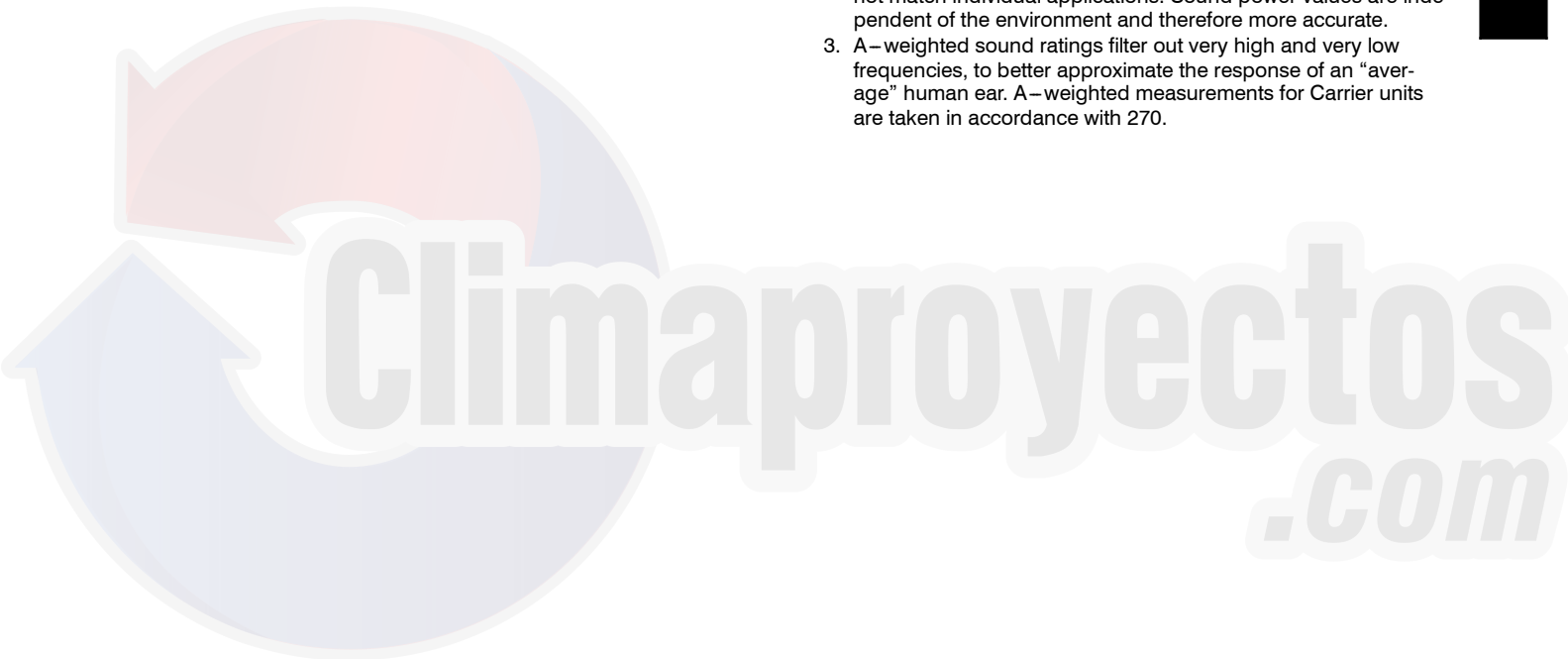

Table 5 – PHYSICAL DATA

(COOLING)

3 - 5 TONS

		50KCQ – A/B04	50KCQ – A/B05	50KCQ – A/B06
Refrigeration System				
	# Circuits / # Comp. / Type	1 / 1 / Scroll	1 / 1 / Scroll	1 / 1 / Scroll
	Puron® refrig. (R-410A) charge (lbs-oz)	14.8	18.0	19.8
	Metering Device	Acutrol	Acutrol	Acutrol
	High–press. Trip / Reset (psig)	630 / 505	630 / 505	630 / 505
	Low–press. Trip / Reset (psig)	27 / 44	27 / 44	27 / 44
Evap. Coil				
	Material (Tube/Fin)	Cu / Al	Cu / Al	Cu / Al
	Coil type	3/8–in RTPF	3/8–in RTPF	3/8–in RTPF
	Rows / FPI	3 / 15	3 / 15	4 / 15
	Total Face Area (ft²)	5.5	5.5	7.3
	Condensate Drain Conn. Size	3/4–in	3/4–in	3/4–in
Evap. Fan and Motor				
Standard Static 1 phase	Motor Qty / Drive Type	1 / Direct	1 / Direct	1 / Direct
	Max BHP	1	1	1
	RPM Range	600–1200	600–1200	600–1200
	Motor Frame Size	48	48	48
	Fan Qty / Type	1 / Centrifugal	1 / Centrifugal	1 / Centrifugal
	Fan Diameter (in)	10 x 10	10 x 10	10 x 10
Standard Static 3 phase	Motor Qty / Drive Type	1 / Direct	1 / Direct	1 / Direct
	Max BHP	1	1	1
	RPM Range	600–1200	600–1200	600–1200
	Motor Frame Size	48	48	48
	Fan Qty / Type	1 / Centrifugal	1 / Centrifugal	1 / Centrifugal
	Fan Diameter (in)	10 x 10	10 x 10	11 x 10
Medium Static 3 phase	Motor Qty / Drive Type	1 / Belt	1 / Belt	1 / Belt
	Max BHP	1.5	1.5	2.0
	RPM Range	819–1251	920–1303	1066–1380
	Motor Frame Size	48	56	56
	Fan Qty / Type	1 / Centrifugal	1 / Centrifugal	1 / Centrifugal
	Fan Diameter (in)	10 x 10	10 x 10	10 x 10
High Static 3 phase	Motor Qty / Drive Type	1 / Belt	1 / Belt	1 / Belt
	Max BHP	2.0	2.0	2.9
	RPM Range	1035–1466	1035–1466	1208–1639
	Motor Frame Size	56	56	56
	Fan Qty / Type	1 / Centrifugal	1 / Centrifugal	1 / Centrifugal
	Fan Diameter (in)	10 x 10	10 x 10	10 x 10
Cond. Coil				
	Material (Tube/Fin)	Cu / Al	Cu / Al	Cu / Al
	Coil type	3/8–in RTPF	3/8–in RTPF	3/8–in RTPF
	Rows / FPI	1 / 17	2 / 17	2 / 17
	Total Face Area (ft²)	16.5	21.3	21.3
Cond. fan / motor				
	Qty / Motor Drive Type	1 / Direct	1 / Direct	1 / Direct
	Motor HP / RPM	1/8 / 825	1/4 / 1100	1/4 / 1100
	Fan diameter (in)	22	22	22
Filters				
	RA Filter # / Size (in)	2 / 16 x 25 x 2	4 / 16 x 16 x 2	4 / 16 x 16 x 2
	OA inlet screen # / Size (in)	1 / 20 x 24 x 1	1 / 20 x 24 x 1	1 / 20 x 24 x 1

50KCQ

Table 6 – 50KCQA04

ELECTRIC HEAT - ELECTRICAL DATA
WITHOUT FACTORY INSTALLED NON-FUSED DISCONNECT

NOM. V-PH-Hz.	IFM TYPE	ELECTRIC HEATER PART NUMBER CRHEATERXXXXXX	NOM PWR (kW)	APP PWR (kW)	SINGLE POINT KIT PART NUMBER CRSINGLEXXXXXX			
					NO C.O. or UNPWRD C.O.		w/PWRD C.O.	
					NO P.E.	w/P.E. (pwrd fr/unit)	NO P.E.	w/P.E. (pwrd fr/unit)
208/230-1-60	DD-STD	101A00	4.4	3.3/4.0	037	037	NA	NA
		102A00	6.5	4.9/6.0	040	040	NA	NA
		103B00	8.7	6.5/8.0	040	040	NA	NA
		104B00	10.5	7.9/9.6	040	040	NA	NA
		102A00,102A00	13.0	9.8/11.9	041	041	NA	NA
208/230-3-60	DD-STD	101A00	4.4	3.3/4.0	-	-	-	-
		102A00	6.5	4.9/6.0	-	-	-	-
		103B00	8.7	6.5/8.0	-	-	037	037
		104B00	10.5	7.9/9.6	037	037	037	037
		105A00	16.0	12.0/14.7	038	038	038	038
	MED	101A00	4.4	3.3/4.0	-	-	-	-
		102A00	6.5	4.9/6.0	-	-	-	-
		103B00	8.7	6.5/8.0	-	-	-	037
		104B00	10.5	7.9/9.6	037	037	037	037
		105A00	16.0	12.0/14.7	038	038	038	038
	HIGH	101A00	4.4	3.3/4.0	-	-	-	-
		102A00	6.5	4.9/6.0	-	-	-	-
		103B00	8.7	6.5/8.0	-	037	037	037
		104B00	10.5	7.9/9.6	037	037	037	038
		105A00	16.0	12.0/14.7	038	038	038	038
460-3-60	DD-STD	106A00	6.0	5.5	-	-	-	-
		107A00	8.8	8.1	-	-	-	-
		108A00	11.5	10.6	-	-	-	-
		109A00	14.0	12.9	-	-	-	-
	MED	106A00	6.0	5.5	-	-	-	-
		107A00	8.8	8.1	-	-	-	-
		108A00	11.5	10.6	-	-	-	-
		109A00	14.0	12.9	-	-	-	-
	HIGH	106A00	6.0	5.5	-	-	-	-
		107A00	8.8	8.1	-	-	-	-
		108A00	11.5	10.6	-	-	-	-
		109A00	14.0	12.9	-	-	-	-

50KCQ

LEGEND

- No Single Point Kit required
- APP PWR - 208 / 230V / 460V / 575V
- BD - Belt drive motor
- C.O. - Convenience outlet
- DD - Electric Drive X13 5 speed/torque motor
- IFM - Indoor fan motor
- NA - Not Available
- NOM PWR - 240V / 480V / 600V
- P.E. - Power exhaust
- PWRD - Powered convenience outlet
- UNPWRD - Unpowered convenience outlet

Table 7 – 50KCQA05

ELECTRIC HEAT - ELECTRICAL DATA
WITHOUT FACTORY INSTALLED NON-FUSED DISCONNECT

NOM. V-PH-Hz.	IFM TYPE	ELECTRIC HEATER PART NUMBER CRHEATERXXXXXX	NOM PWR (kW)	APP PWR (kW)	SINGLE POINT KIT PART NUMBER CRSINGLEXXXXXX			
					NO C.O. or UNPWRD C.O.		w/PWRD C.O.	
					NO P.E.	w/P.E. (pwrd fr/unit)	NO P.E.	w/P.E. (pwrd fr/unit)
208/230-1-60	DD-STD	101A00	4.4	3.3/4.0	037	040	NA	NA
		103B00	8.7	6.5/8.0	040	040	NA	NA
		102A00,102A00	13.0	9.8/11.9	041	041	NA	NA
		103B00,103B00	17.4	13.1/16.0	041	041	NA	NA
		104B00,104B00	21.0	15.8/19.3	041	041	NA	NA
208/230-3-60	DD-STD	102A00	6.5	4.9/6.0	-	-	037	037
		103B00	8.7	6.5/8.0	037	037	037	037
		105A00	16.0	12.0/14.7	038	038	038	038
		104B00,104B00	21.0	15.8/19.3	039	039	039	039
	MED	102A00	6.5	4.9/6.0	-	-	-	-
		103B00	8.7	6.5/8.0	-	037	037	037
		105A00	16.0	12.0/14.7	038	038	038	038
		104B00,104B00	21.0	15.8/19.3	039	039	039	039
	HIGH	102A00	6.5	4.9/6.0	-	-	037	037
		103B00	8.7	6.5/8.0	037	037	037	037
		105A00	16.0	12.0/14.7	038	038	038	038
		104B00,104B00	21.0	15.8/19.3	039	039	039	039
460-3-60	DD-STD	106A00	6.0	5.5	-	-	-	-
		108A00	11.5	10.6	-	-	-	-
		109A00	14.0	12.9	-	-	-	-
		108A00,108A00	23.0	21.1	037	037	037	037
	MED	106A00	6.0	5.5	-	-	-	-
		108A00	11.5	10.6	-	-	-	-
		109A00	14.0	12.9	-	-	-	-
		108A00,108A00	23.0	21.1	037	037	037	037
	HIGH	106A00	6.0	5.5	-	-	-	-
		108A00	11.5	10.6	-	-	-	-
		109A00	14.0	12.9	-	-	-	-
		108A00,108A00	23.0	21.1	037	037	037	037

LEGEND

- No Single Point Kit required
- APP PWR - 208 / 230V / 460V / 575V
- BD - Belt drive motor
- C.O. - Convenience outlet
- DD - Electric Drive X13 5 speed/torque motor
- IFM - Indoor fan motor
- NA - Not Available
- NOM PWR - 240V / 480V / 600V
- P.E. - Power exhaust
- PWRD - Powered convenience outlet
- UNPWRD - Unpowered convenience outlet

50KCQA

Table 8 – 50KCQA06

ELECTRIC HEAT - ELECTRICAL DATA
WITHOUT FACTORY INSTALLED NON-FUSED DISCONNECT

NOM. V-PH-Hz.	IFM TYPE	ELECTRIC HEATER PART NUMBER CRHEATERXXXXXX	NOM PWR (kW)	APP PWR (kW)	SINGLE POINT KIT PART NUMBER CRSINGLEXXXXXX			
					NO C.O. or UNPWRD C.O.		w/PWRD C.O.	
					NO P.E.	w/P.E. (pwrd fr/unit)	NO P.E.	w/P.E. (pwrd fr/unit)
208/230-1-60	DD-STD	102A00	6.5	4.9/6.0	040	040	NA	NA
		103B00	8.7	6.5/8.0	040	040	NA	NA
		102A00,102A00	13.0	9.8/11.9	041	041	NA	NA
		103B00,103B00	17.4	13.1/16.0	041	041	NA	NA
		104B00,104B00	21.0	15.8/19.3	041	041	NA	NA
208/230-3-60	DD-STD	102A00	6.5	4.9/6.0	-	037	037	037
		104B00	10.5	7.9/9.6	038	038	038	038
		105A00	16.0	12.0/14.7	038	038	038	038
		104B00,104B00	21.0	15.8/19.3	039	039	039	039
		104B00,105A00	26.5	19.9/24.3	039	039	039	039
	MED	102A00	6.5	4.9/6.0	-	037	037	037
		104B00	10.5	7.9/9.6	038	038	038	038
		105A00	16.0	12.0/14.7	038	038	038	038
		104B00,104B00	21.0	15.8/19.3	039	039	039	039
		104B00,105A00	26.5	19.9/24.3	039	039	039	039
	HIGH	102A00	6.5	4.9/6.0	-	037	037	037
		104B00	10.5	7.9/9.6	038	038	038	038
		105A00	16.0	12.0/14.7	038	038	038	038
		104B00,104B00	21.0	15.8/19.3	039	039	039	039
		104B00,105A00	26.5	19.9/24.3	039	039	039	039
460-3-60	DD-STD	106A00	6.0	5.5	-	-	-	-
		108A00	11.5	10.6	-	-	-	-
		109A00	14.0	12.9	-	-	-	-
		108A00,108A00	23.0	21.1	037	037	037	037
		108A00,109A00	25.5	23.4	037	037	037	037
	MED	106A00	6.0	5.5	-	-	-	-
		108A00	11.5	10.6	-	-	-	-
		109A00	14.0	12.9	-	-	-	-
		108A00,108A00	23.0	21.1	037	037	037	037
		108A00,109A00	25.5	23.4	037	037	037	037
	HIGH	106A00	6.0	5.5	-	-	-	-
		108A00	11.5	10.6	-	-	-	-
		109A00	14.0	12.9	-	-	-	-
		108A00,108A00	23.0	21.1	037	037	037	037
		108A00,109A00	25.5	23.4	037	037	037	037

50KCA

LEGEND

- No Single Point Kit required
- APP PWR - 208 / 230V / 460V / 575V
- BD - Belt drive motor
- C.O. - Convenience outlet
- DD - Electric Drive X13 5 speed/torque motor
- IFM - Indoor fan motor
- NA - Not Available
- NOM PWR - 240V / 480V / 600V
- P.E. - Power exhaust
- PWRD - Powered convenience outlet
- UNPWRD - Unpowered convenience outlet

Table 9 – 50KCQA04

ELECTRIC HEAT - ELECTRICAL DATA
WITH FACTORY INSTALLED NON-FUSED DISCONNECT

NOM. V-PH-Hz.	IFM TYPE	ELECTRIC HEATER PART NUMBER CRHEATERXXXXXX	NOM PWR (kW)	APP PWR (kW)	SINGLE POINT KIT PART NUMBER CRSINGLEXXXXXX			
					NO C.O. or UNPWRD C.O.		w/PWRD C.O.	
					NO P.E.	w/P.E. (pwrd fr/unit)	NO P.E.	w/P.E. (pwrd fr/unit)
208/230-1-60	DD-STD	101A00	4.4	3.3/4.0	037	037	NA	NA
		102A00	6.5	4.9/6.0	040	040	NA	NA
		103B00	8.7	6.5/8.0	040	040	NA	NA
		104B00	10.5	7.9/9.6	040	040	NA	NA
		102A00,102A00	13.0	9.8/11.9	041	041	NA	NA
208/230-3-60	DD-STD	101A00	4.4	3.3/4.0	037	037	037	037
		102A00	6.5	4.9/6.0	037	037	037	037
		103B00	8.7	6.5/8.0	037	037	037	037
		104B00	10.5	7.9/9.6	037	037	037	037
		105A00	16.0	12.0/14.7	038	038	038	038
	MED	101A00	4.4	3.3/4.0	037	037	037	037
		102A00	6.5	4.9/6.0	037	037	037	037
		103B00	8.7	6.5/8.0	037	037	037	037
		104B00	10.5	7.9/9.6	037	037	037	037
		105A00	16.0	12.0/14.7	038	038	038	038
	HIGH	101A00	4.4	3.3/4.0	037	037	037	037
		102A00	6.5	4.9/6.0	037	037	037	037
		103B00	8.7	6.5/8.0	037	037	037	037
		104B00	10.5	7.9/9.6	037	037	037	038
		105A00	16.0	12.0/14.7	038	038	038	038
460-3-60	DD-STD	106A00	6.0	5.5	-	-	-	-
		107A00	8.8	8.1	-	-	-	-
		108A00	11.5	10.6	-	-	-	-
		109A00	14.0	12.9	-	-	-	-
	MED	106A00	6.0	5.5	-	-	-	-
		107A00	8.8	8.1	-	-	-	-
		108A00	11.5	10.6	-	-	-	-
		109A00	14.0	12.9	-	-	-	-
	HIGH	106A00	6.0	5.5	-	-	-	-
		107A00	8.8	8.1	-	-	-	-
		108A00	11.5	10.6	-	-	-	-
		109A00	14.0	12.9	-	-	-	-

LEGEND

- No Single Point Kit required
- APP PWR - 208 / 230V / 460V / 575V
- BD - Belt drive motor
- C.O. - Convenience outlet
- DD - Electric Drive X13 5 speed/torque motor
- IFM - Indoor fan motor
- NA - Not Available
- NOM PWR - 240V / 480V / 600V
- P.E. - Power exhaust
- PWRD - Powered convenience outlet
- UNPWRD - Unpowered convenience outlet

50KCQ

Table 10 – 50KCA05

ELECTRIC HEAT - ELECTRICAL DATA
WITH FACTORY INSTALLED NON-FUSED DISCONNECT

NOM. V-PH-Hz.	IFM TYPE	ELECTRIC HEATER PART NUMBER CRHEATERXXXXXX	NOM PWR (kW)	APP PWR (kW)	SINGLE POINT KIT PART NUMBER CRSINGLEXXXXXX			
					NO C.O. or UNPWRD C.O.		w/PWRD C.O.	
					NO P.E.	w/P.E. (pwrd fr/unit)	NO P.E.	w/P.E. (pwrd fr/unit)
208/230-1-60	DD-STD	101A00	4.4	3.3/4.0	037	040	NA	NA
		103B00	8.7	6.5/8.0	040	040	NA	NA
		102A00,102A00	13.0	9.8/11.9	041	041	NA	NA
		103B00,103B00	17.4	13.1/16.0	041	041	NA	NA
		104B00,104B00	21.0	15.8/19.3	041	041	NA	NA
208/230-3-60	DD-STD	102A00	6.5	4.9/6.0	037	037	037	037
		103B00	8.7	6.5/8.0	037	037	037	037
		105A00	16.0	12.0/14.7	038	038	038	038
		104B00,104B00	21.0	15.8/19.3	039	039	039	039
	MED	102A00	6.5	4.9/6.0	037	037	037	037
		103B00	8.7	6.5/8.0	037	037	037	037
		105A00	16.0	12.0/14.7	038	038	038	038
		104B00,104B00	21.0	15.8/19.3	039	039	039	039
	HIGH	102A00	6.5	4.9/6.0	037	037	037	037
		103B00	8.7	6.5/8.0	037	037	037	037
		105A00	16.0	12.0/14.7	038	038	038	038
		104B00,104B00	21.0	15.8/19.3	039	039	039	039
460-3-60	DD-STD	106A00	6.0	5.5	-	-	-	-
		108A00	11.5	10.6	-	-	-	-
		109A00	14.0	12.9	-	-	-	-
		108A00,108A00	23.0	21.1	037	037	037	037
	MED	106A00	6.0	5.5	-	-	-	-
		108A00	11.5	10.6	-	-	-	-
		109A00	14.0	12.9	-	-	-	-
		108A00,108A00	23.0	21.1	037	037	037	037
	HIGH	106A00	6.0	5.5	-	-	-	-
		108A00	11.5	10.6	-	-	-	-
		109A00	14.0	12.9	-	-	-	-
		108A00,108A00	23.0	21.1	037	037	037	037

50KCA

LEGEND

- No Single Point Kit required
- APP PWR - 208 / 230V / 460V / 575V
- BD - Belt drive motor
- C.O. - Convenience outlet
- DD - Electric Drive X13 5 speed/torque motor
- IFM - Indoor fan motor
- NA - Not Available
- NOM PWR - 240V / 480V / 600V
- PE. - Power exhaust
- PWRD - Powered convenience outlet
- UNPWRD - Unpowered convenience outlet

Table 11 – 50KCQA06

ELECTRIC HEAT - ELECTRICAL DATA
WITH FACTORY INSTALLED NON-FUSED DISCONNECT

NOM. V-PH-Hz.	IFM TYPE	ELECTRIC HEATER PART NUMBER CRHEATERXXXXXX	NOM PWR (kW)	APP PWR (kW)	SINGLE POINT KIT PART NUMBER CRSINGLEXXXXXX			
					NO C.O. or UNPWRD C.O.		w/PWRD C.O.	
					NO P.E.	w/P.E. (pwrd fr/unit)	NO P.E.	w/P.E. (pwrd fr/unit)
208/230-1-60	DD-STD	102A00	6.5	4.9/6.0	040	040	NA	NA
		103B00	8.7	6.5/8.0	040	040	NA	NA
		102A00,102A00	13.0	9.8/11.9	041	041	NA	NA
		103B00,103B00	17.4	13.1/16.0	041	041	NA	NA
		104B00,104B00	21.0	15.8/19.3	041	041	NA	NA
208/230-3-60	DD-STD	102A00	6.5	4.9/6.0	037	037	037	037
		104B00	10.5	7.9/9.6	038	038	038	038
		105A00	16.0	12.0/14.7	038	038	038	038
		104B00,104B00	21.0	15.8/19.3	039	039	039	039
		104B00,105A00	26.5	19.9/24.3	039	039	039	039
	MED	102A00	6.5	4.9/6.0	037	037	037	037
		104B00	10.5	7.9/9.6	038	038	038	038
		105A00	16.0	12.0/14.7	038	038	038	038
		104B00,104B00	21.0	15.8/19.3	039	039	039	039
		104B00,105A00	26.5	19.9/24.3	039	039	039	039
	HIGH	102A00	6.5	4.9/6.0	037	037	037	037
		104B00	10.5	7.9/9.6	038	038	038	038
		105A00	16.0	12.0/14.7	038	038	038	038
		104B00,104B00	21.0	15.8/19.3	039	039	039	039
		104B00,105A00	26.5	19.9/24.3	039	039	039	039
460-3-60	DD-STD	106A00	6.0	5.5	-	-	-	-
		108A00	11.5	10.6	-	-	-	-
		109A00	14.0	12.9	-	-	-	-
		108A00,108A00	23.0	21.1	037	037	037	037
		108A00,109A00	25.5	23.4	037	037	037	037
	MED	106A00	6.0	5.5	-	-	-	-
		108A00	11.5	10.6	-	-	-	-
		109A00	14.0	12.9	-	-	-	-
		108A00,108A00	23.0	21.1	037	037	037	037
		108A00,109A00	25.5	23.4	037	037	037	037
	HIGH	106A00	6.0	5.5	-	-	-	-
		108A00	11.5	10.6	-	-	-	-
		109A00	14.0	12.9	-	-	-	-
		108A00,108A00	23.0	21.1	037	037	037	037
		108A00,109A00	25.5	23.4	037	037	037	037

LEGEND

- No Single Point Kit required
- APP PWR - 208 / 230V / 460V / 575V
- BD - Belt drive motor
- C.O. - Convenience outlet
- DD - Electric Drive X13 5 speed/torque motor
- IFM - Indoor fan motor
- NA - Not Available
- NOM PWR - 240V / 480V / 600V
- P.E. - Power exhaust
- PWRD - Powered convenience outlet
- UNPWRD - Unpowered convenience outlet

WEIGHTS & DIMENSIONS

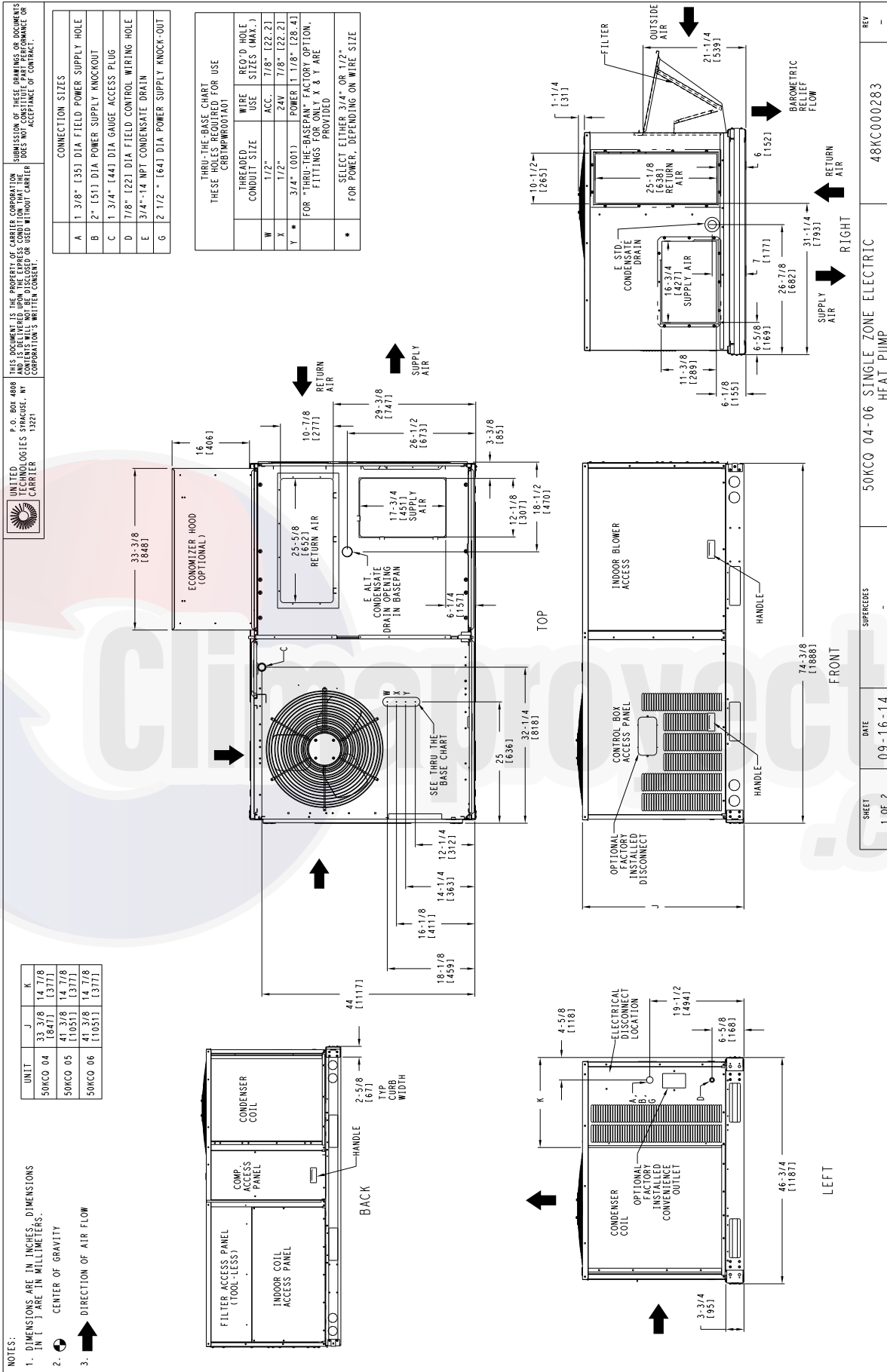

Fig. 1 - Dimensions 50KCQ 04-06 (sheet 1 of 2)



WEIGHTS & DIMENSIONS (cont.)

50KCQ

UNITED TECHNOLOGIES CARRIER
 P. O. BOX 4808
 THIS DOCUMENT IS THE PROPERTY OF CARRIER CORPORATION AND IS DELIVERED UPON THE EXPRESS CONDITION THAT THE USER WILL NOT REPRODUCE OR USE WITHOUT CARRIER CORPORATION'S WRITTEN CONSENT.
 SUBMISSION OF THESE DRAWINGS OR DOCUMENTS DOES NOT CONSTITUTE PART PERFORMANCE OR ACCEPTANCE OF CONTRACT.

UNIT	STD. UNIT WEIGHT (LBS.)		CORNER WEIGHT (LBS.)		CORNER WEIGHT (KG.)		CORNER WEIGHT (LBS.)		CORNER WEIGHT (KG.)		C. G.	HEIGHT
	495	224	130	59	118	53	130	59	118	53		
50KCO 04	495	224	130	59	118	53	35 3/8	1898	23 3/8	1584.1	18 3/8	[467]
50KCO 05	560	263	161	73	147	66	35 1/2	1902.1	21 7/8	1555.1	20 1/2	[521]
50KCO 06	610	276	165	75	152	69	35 3/4	1908	22 1/2	1571.1	20 3/4	[527]

* STANDARD UNIT WEIGHT IS WITHOUT ELECTRIC HEAT AND WITHOUT PACKAGING. FOR OTHER OPTIONS AND ACCESSORIES, REFER TO THE PRODUCT DATA CATALOG.

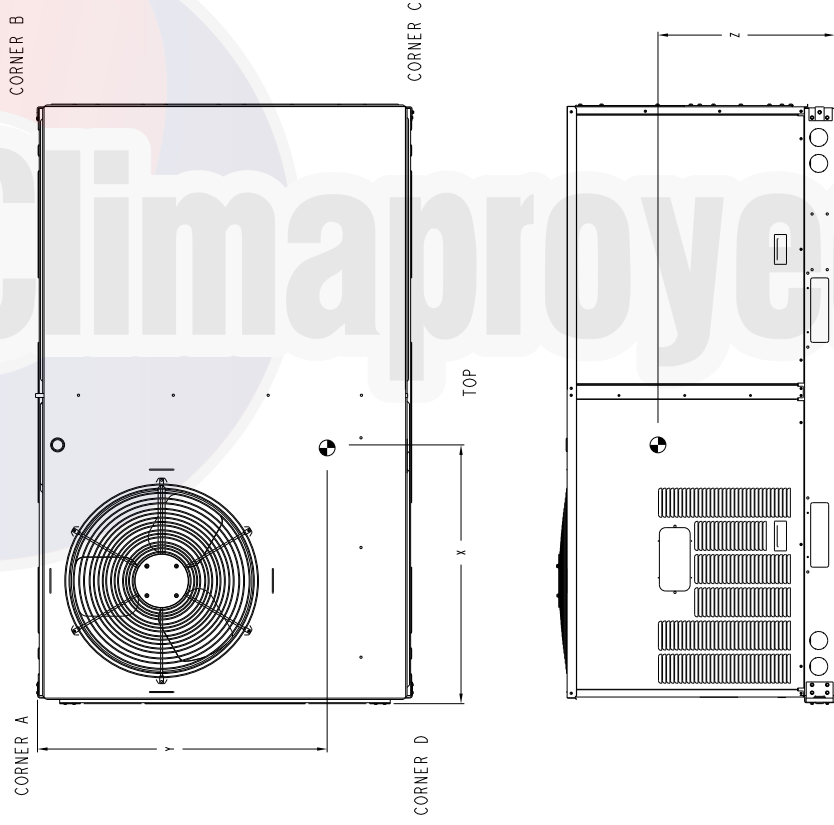

SHEET 2 OF 2	DATE 09-16-14	SUPERCEDES -	50KCO 04-06 SINGLE-ZONE ELECTRIC HEAT PUMP	REV -
			48KC000283	

Fig. 2 - Dimensions 50KCQ 04-06 (sheet 2 of 2)

WEIGHTS & DIMENSIONS (cont.)

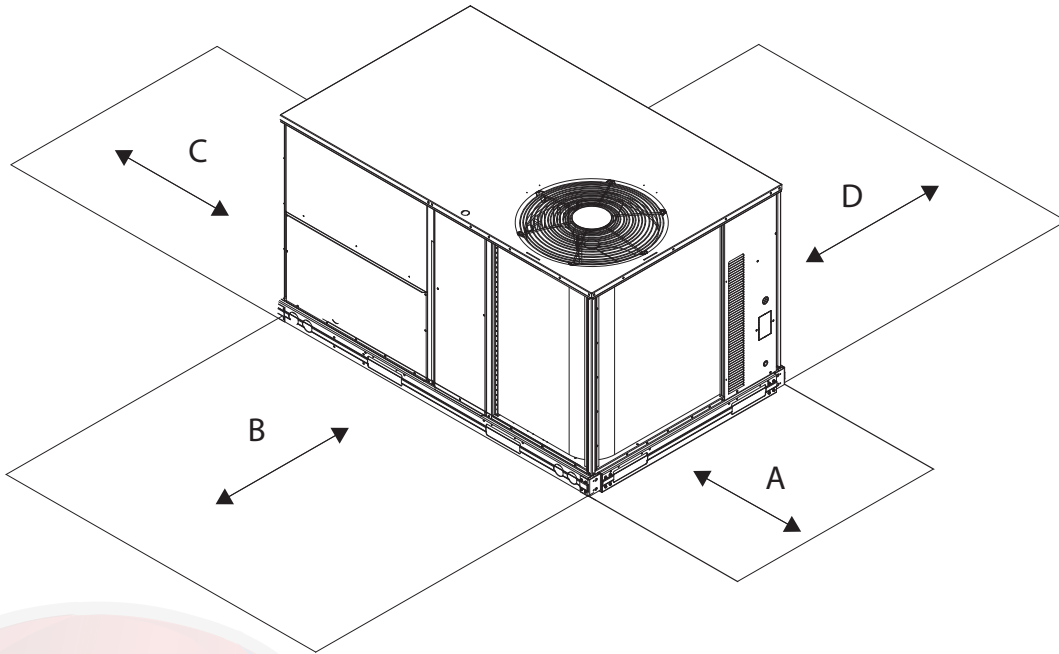

50KCG

C08337

LOCATION	DIMENSION	CONDITION
A	48-in (1219 mm) 18-in (457 mm) 18-in (457 mm) 12-in (305 mm)	Unit disconnect is mounted on panel No disconnect, convenience outlet option Recommended service clearance Minimum clearance
B	42-in (1067 mm) 36-in (914 mm) Special	Surface behind servicer is grounded (e.g., metal, masonry wall) Surface behind servicer is electrically non-conductive (e.g., wood, fiberglass) Check sources of flue products within 10-ft of unit fresh air intake hood
C	36-in (914 mm) 18-in (457 mm)	Side condensate drain is used Minimum clearance
D	42-in (1067 mm) 36-in (914 mm) Special	Surface behind servicer is grounded (e.g., metal, masonry wall, another unit) Surface behind servicer is electrically non-conductive (e.g., wood, fiberglass) Check for adjacent units or building fresh air intakes within 10-ft (3 m) of this unit's flue outlet

NOTE: Unit not designed to have overhead obstruction. Contact Application Engineering for guidance on any application planning overhead obstruction or for vertical clearances.

Fig. 3 - Service Clearance

WEIGHTS & DIMENSIONS (cont.)

50KCQ

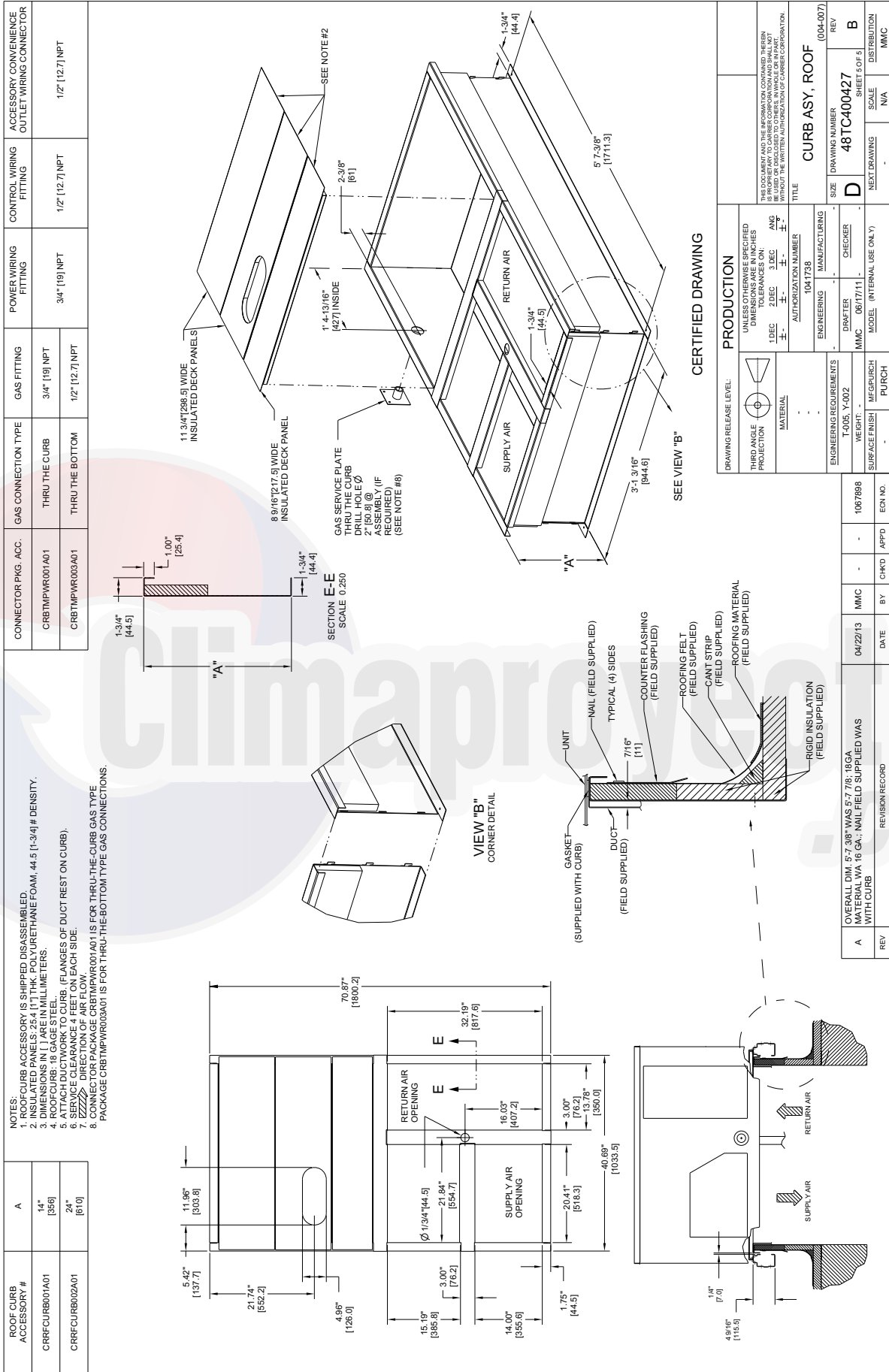

Fig. 4 - Curb Dimensions 50KCQ 04-06

OPTION / ACCESSORY WEIGHTS

OPTION / ACCESSORY	OPTION / ACCESSORY WEIGHTS					
	04		05		06	
	lb	kg	lb	kg	lb	kg
Power Exhaust – vertical	45	20	45	22	45	20
Power Exhaust – horizontal	30	14	30	14	30	14
EconoMi\$er (IV, X or 2)	35	16	35	16	35	16
Two Position damper	39	18	39	18	39	18
Manual Dampers	12	5	12	5	12	5
Hail Guard (louvered)	13	6	13	6	17	8
Cu/Cu Condenser Coil ¹	37	17	95	43	95	43
Cu/Cu Condenser and Evaporator Coils ¹	75	34	165	75	165	75
Roof Curb (14–in. curb)	115	52	115	52	115	52
Roof Curb (24–in. curb)	197	89	197	89	197	89
CO ₂ sensor	2	1	2	1	2	1
Electric Heater	10	5	12	5	12	5
Single Point Kit	10	5	10	5	10	5
Optional Indoor Motor/Drive	6	3	6	3	17	8
Motor Master Controller	35	16	35	16	35	16
Return Smoke Detector	7	3	7	3	7	3
Supply Smoke Detector	7	3	7	3	7	3
Non – Fused Disconnect	15	7	15	7	15	7
Powered Convenience outlet	36	16	36	16	36	16
Non – Powered Convenience outlet	4	2	4	2	4	2
Enthalpy Sensor	2	1	2	1	2	1
Differential Enthalpy Sensor	3	1	3	1	3	1

50KCG

NOTE: Where multiple variations are available, the heaviest combination is listed.

– Not Available

¹ Where available.

APPLICATION DATA

Min operating ambient temp (cooling):

In mechanical cooling mode, your Carrier rooftop can safely operate down to an outdoor ambient temperature of 25°F (-4°C). It is possible to provide cooling at lower outdoor ambient temperatures by using less outside air, economizers, and/or accessory low ambient kits.

Max operating ambient temp (cooling):

The maximum operating ambient temperature for cooling mode is 115°F (46°C). While cooling operation above 115°F (46°C) may be possible, it could cause either a reduction in performance, reliability, or a protective action by the unit's internal safety devices.

Min and max airflow (cooling mode):

To maintain safe and reliable operation of your rooftop, operate within the cooling airflow limits. Operating above the max may cause blow-off, undesired airflow noise, or airflow related problems with the rooftop unit. Operating below the min may cause problems with coil freeze-up.

Airflow:

All units are draw-through in cooling mode.

Outdoor air application strategies:

Economizers reduce operating expenses and compressor run time by providing a free source of cooling and a means of ventilation to match application changing needs. In fact, they should be considered for most applications. Also, consider the various economizer control methods and their benefits, as well as sensors required to accomplish your application goals. Please contact your local Carrier representative for assistance.

Motor limits, Brake horsepower (BHP):

Due to Carrier's internal unit design, air path, and specially designed motors, the full horsepower (maximum continuous BHP) band, as listed in this manual, can be used with the utmost confidence. There is no need for extra safety factors, as Carrier's motors are designed and rigorously tested to use the entire, listed BHP range without either nuisance tripping or premature motor failure.

Sizing a rooftop

Bigger isn't necessarily better. While an air conditioner needs to have enough capacity to meet the load, it doesn't need excess capacity. In fact, having excess capacity typically results in very poor part load performance and humidity control.

Using higher design temperatures than ASHRAE recommends for your location, adding "safety factors" to the calculated load, and rounding up to the next largest unit, are all signs of oversizing air conditioners. Oversizing can cause short-cycling, and short cycling leads to poor humidity control, reduced efficiency, higher utility bills, drastic indoor temperature swings, excessive noise, and increased wear and tear on the air conditioner.

Rather than oversizing an air conditioner, wise contractors and engineers "right-size" or even slightly undersize air conditioners. Correctly sizing an air conditioner controls humidity better; promotes efficiency; reduces utility bills; extends equipment life, and maintains even, comfortable temperatures.

Low ambient applications

When equipped with a Carrier economizer, your rooftop unit can cool your space by bringing in fresh, cool outside air. In fact, when so equipped, accessory low ambient kit may not be necessary. In low ambient conditions, unless the outdoor air is excessively humid or contaminated, economizer-based "free cooling" is the preferred less costly and energy conscious method.

In low ambient applications where outside air might not be desired (such as contaminated or excessively humid outdoor environments), your Carrier rooftop can operate at ambient temperatures down to -20°F (-29°C) using the recommended accessory Motormaster low ambient controller.

Table 12 – COOLING CAPACITIES

1-STAGE COOLING

3 TONS

50KCQA04			Ambient Temperature												
			85			95			105			115			
			EA (dB)			EA (dB)			EA (dB)			EA (dB)			
			75	80	85	75	80	85	75	80	85	75	80	85	
900 Cfm	EAT (wb)	58	THC	29.5	29.5	33.5	28.3	28.3	32.2	26.3	26.3	30.0	24.2	24.2	27.6
		SHC	25.4	29.5	33.5	24.5	28.3	32.2	22.7	26.3	30.0	20.8	24.2	27.6	
	62	THC	31.5	31.5	31.9	29.9	29.9	31.3	27.4	27.4	29.9	24.6	24.6	28.3	
		SHC	22.9	27.4	31.9	22.4	26.8	31.3	21.0	25.4	29.9	19.5	23.9	28.3	
	67	THC	35.4	35.4	35.4	33.7	33.7	33.7	31.1	31.1	31.1	28.3	28.3	28.3	
		SHC	18.9	23.4	27.9	18.4	22.8	27.3	17.1	21.6	26.1	15.8	20.3	24.7	
	72	THC	39.4	39.4	39.4	37.8	37.8	37.8	35.3	35.3	35.3	32.4	32.4	32.4	
		SHC	14.6	19.1	23.7	14.2	18.7	23.2	13.1	17.6	22.1	11.8	16.3	20.8	
	76	THC	-	42.1	42.1	-	40.6	40.6	-	38.3	38.3	-	35.6	35.6	
		SHC	-	15.5	20.4	-	15.2	20.2	-	14.2	19.1	-	13.0	17.8	
1050 Cfm	EAT (wb)	58	THC	31.4	31.4	35.7	30.2	30.2	34.3	28.1	28.1	32.0	25.9	25.9	29.5
		SHC	27.1	31.4	35.7	26.1	30.2	34.3	24.3	28.1	32.0	22.3	25.9	29.5	
	62	THC	32.8	32.8	35.1	31.1	31.1	34.4	29.0	29.0	31.4	26.4	26.4	29.5	
		SHC	24.9	30.0	35.1	24.3	29.3	34.4	22.2	26.8	31.4	20.5	25.0	29.5	
	67	THC	36.8	36.8	36.8	35.0	35.0	35.0	32.2	32.2	32.2	29.3	29.3	29.3	
		SHC	20.2	25.3	30.5	19.7	24.8	30.0	18.4	23.5	28.7	17.1	22.2	27.3	
	72	THC	40.5	40.5	40.5	39.0	39.0	39.0	36.4	36.4	36.4	33.6	33.6	33.6	
		SHC	15.1	20.3	25.4	14.8	19.9	25.1	13.6	18.8	23.9	12.4	17.6	22.7	
	76	THC	-	43.0	43.0	-	41.5	41.5	-	39.1	39.1	-	36.5	36.5	
		SHC	-	16.2	21.9	-	15.8	21.4	-	14.8	20.3	-	13.6	19.0	
1200 Cfm	EAT (wb)	58	THC	33.1	33.1	37.6	31.8	31.8	36.1	29.7	29.7	33.7	27.3	27.3	31.1
		SHC	28.6	33.1	37.6	27.5	31.8	36.1	25.6	29.7	33.7	23.5	27.3	31.1	
	62	THC	33.8	33.8	38.0	32.2	32.2	36.9	30.5	30.5	32.5	27.4	27.4	32.4	
		SHC	26.7	32.4	38.0	25.8	31.4	36.9	23.1	27.8	32.5	22.3	27.4	32.4	
	67	THC	37.8	37.8	37.8	36.0	36.0	36.0	33.1	33.1	33.1	30.1	30.1	30.1	
		SHC	21.4	27.1	32.9	20.9	26.7	32.5	19.6	25.4	31.2	18.3	24.0	29.8	
	72	THC	41.3	41.3	41.3	39.8	39.8	39.8	37.3	37.3	37.3	34.4	34.4	34.4	
		SHC	15.5	21.2	26.9	15.2	20.9	26.7	14.1	19.9	25.6	12.9	18.7	24.5	
	76	THC	-	43.7	43.7	-	42.1	42.1	-	39.7	39.7	-	37.1	37.1	
		SHC	-	16.6	22.8	-	16.3	22.4	-	15.2	21.3	-	14.1	20.1	
1350 Cfm	EAT (wb)	58	THC	34.5	34.5	39.2	33.2	33.2	37.6	30.9	30.9	35.2	28.6	28.6	32.5
		SHC	29.8	34.5	39.2	28.7	33.2	37.6	26.7	30.9	35.2	24.6	28.6	32.5	
	62	THC	34.7	34.7	40.9	33.2	33.2	39.2	31.7	31.7	33.9	28.6	28.6	33.8	
		SHC	28.4	34.7	40.9	27.3	33.2	39.2	24.1	29.0	33.9	23.3	28.6	33.8	
	67	THC	38.6	38.6	38.6	36.8	36.8	36.8	33.9	33.9	33.9	30.7	30.7	32.2	
		SHC	22.4	28.8	35.1	22.0	28.4	34.8	20.8	27.2	33.7	19.4	25.8	32.2	
	72	THC	42.0	42.0	42.0	40.4	40.4	40.4	37.9	37.9	37.9	35.0	35.0	35.0	
		SHC	15.9	22.1	28.3	15.6	21.8	28.1	14.5	20.8	27.2	13.3	19.7	26.1	
	76	THC	-	44.2	44.2	-	42.6	42.6	-	40.2	40.2	-	37.5	37.5	
		SHC	-	17.0	23.6	-	16.6	23.2	-	15.6	22.1	-	14.5	21.0	
1500 Cfm	EAT (wb)	58	THC	35.8	35.8	40.6	34.4	34.4	39.0	32.1	32.1	36.4	29.6	29.6	33.7
		SHC	30.9	35.8	40.6	29.8	34.4	39.0	27.7	32.1	36.4	25.5	29.6	33.7	
	62	THC	35.9	35.9	42.3	34.5	34.5	40.7	32.1	32.1	37.9	29.6	29.6	35.1	
		SHC	29.4	35.9	42.3	28.3	34.5	40.7	26.3	32.1	37.9	24.2	29.6	35.1	
	67	THC	39.2	39.2	39.2	37.4	37.4	37.4	34.5	34.5	35.9	31.3	31.3	34.5	
		SHC	23.4	30.3	37.2	23.1	30.0	37.0	21.8	28.9	35.9	20.4	27.5	34.5	
	72	THC	42.5	42.5	42.5	40.9	40.9	40.9	38.4	38.4	38.4	35.5	35.5	35.5	
		SHC	16.2	22.8	29.5	15.9	22.6	29.4	14.8	21.7	28.5	13.7	20.6	27.6	
	76	THC	-	44.6	44.6	-	43.0	43.0	-	40.5	40.5	-	37.8	37.8	
		SHC	-	17.3	24.4	-	16.9	24.0	-	15.9	22.9	-	14.9	21.8	

50KCC

LEGEND

- Do not operate in this region (Points are outside SST and SDT permissible operating range)
- Cfm - Cubic feet per minute (supply air)
- EAT(db) - Entering air temperature (dry bulb)
- EAT(wb) - Entering air temperature (wet bulb)
- SHC - Sensible heat capacity
- THC - Total capacity

Table 13 – COOLING CAPACITIES

1-STAGE COOLING

4 TONS

50KQA05			Ambient Temperature												
			85			95			105			115			
			EA (dB)			EA (dB)			EA (dB)			EA (dB)			
			75	80	85	75	80	85	75	80	85	75	80	85	
1200 Cfm	EAT (wb)	58	THC	41.5	41.5	47.0	39.6	39.6	44.8	37.5	37.5	42.5	35.2	35.2	39.9
		SHC	36.0	41.5	47.0	34.4	39.6	44.8	32.6	37.5	42.5	30.6	35.2	39.9	
	62	THC	44.3	44.3	44.6	41.6	41.6	43.3	38.9	38.9	42.0	35.9	35.9	40.5	
		SHC	32.6	38.6	44.6	31.4	37.4	43.3	30.1	36.1	42.0	28.7	34.6	40.5	
	67	THC	49.2	49.2	49.2	46.5	46.5	46.5	43.4	43.4	43.4	40.4	40.4	40.4	
		SHC	27.1	33.1	39.1	26.0	32.0	38.1	24.7	30.7	36.7	23.4	29.5	35.5	
	72	THC	52.2	52.2	52.2	51.1	51.1	51.1	48.6	48.6	48.6	45.4	45.4	45.4	
		SHC	20.6	26.5	32.4	20.2	26.2	32.2	19.2	25.3	31.3	18.0	24.1	30.1	
	76	THC	-	53.2	53.2	-	52.9	52.9	-	51.6	51.6	-	49.1	49.1	
		SHC	-	21.0	27.6	-	20.9	27.5	-	20.4	27.0	-	19.5	25.9	
1400 Cfm	EAT (wb)	58	THC	44.0	44.0	49.9	41.9	41.9	47.5	39.7	39.7	44.9	37.3	37.3	42.2
		SHC	38.2	44.0	49.9	36.4	41.9	47.5	34.5	39.7	44.9	32.4	37.3	42.2	
	62	THC	45.9	45.9	48.9	43.1	43.1	47.5	40.3	40.3	45.9	37.4	37.4	44.0	
		SHC	35.1	42.0	48.9	33.8	40.6	47.5	32.4	39.2	45.9	30.8	37.4	44.0	
	67	THC	50.6	50.6	50.6	48.2	48.2	48.2	44.8	44.8	44.8	41.6	41.6	41.6	
		SHC	28.5	35.2	42.0	27.6	34.5	41.4	26.3	33.2	40.1	25.0	31.9	38.8	
	72	THC	52.6	52.6	52.6	52.0	52.0	52.0	49.9	49.9	49.9	46.8	46.8	46.8	
		SHC	20.8	27.2	33.6	20.6	27.3	34.0	19.8	26.7	33.6	18.7	25.6	32.5	
	76	THC	-	53.4	53.4	-	53.3	53.3	-	52.1	52.1	-	49.9	49.9	
		SHC	-	21.6	29.3	-	21.5	29.2	-	21.0	28.4	-	20.2	27.4	
1600 Cfm,	EAT (wb)	58	THC	46.2	46.2	52.4	43.9	43.9	49.7	41.6	41.6	47.0	39.0	39.0	44.2
		SHC	40.1	46.2	52.4	38.1	43.9	49.7	36.1	41.6	47.0	33.9	39.0	44.2	
	62	THC	47.3	47.3	52.7	44.4	44.4	51.1	42.3	42.3	46.4	39.1	39.1	46.0	
		SHC	37.4	45.1	52.7	36.0	43.6	51.1	33.1	39.7	46.4	32.2	39.1	46.0	
	67	THC	51.3	51.3	51.3	49.3	49.3	49.3	46.0	46.0	46.0	42.5	42.5	42.5	
		SHC	29.5	36.9	44.3	29.1	36.7	44.4	27.8	35.6	43.4	26.5	34.3	42.1	
	72	THC	52.8	52.8	52.8	52.5	52.5	52.5	50.8	50.8	50.8	47.7	47.7	47.7	
		SHC	20.9	27.7	34.6	20.8	28.1	35.4	20.3	27.9	35.5	19.2	27.0	34.7	
	76	THC	-	53.6	53.6	-	53.6	53.6	-	52.5	52.5	-	50.4	50.4	
		SHC	-	21.9	30.3	-	21.8	29.9	-	21.3	29.3	-	20.6	28.6	
1800 Cfm	EAT (wb)	58	THC	48.0	48.0	54.3	45.7	45.7	51.8	43.1	43.1	48.8	40.5	40.5	45.9
		SHC	41.6	48.0	54.3	39.7	45.7	51.8	37.4	43.1	48.8	35.2	40.5	45.9	
	62	THC	48.9	48.9	53.8	46.4	46.4	52.7	43.7	43.7	48.6	40.6	40.6	47.7	
		SHC	38.3	46.0	53.8	37.2	45.0	52.7	34.5	41.6	48.6	33.4	40.6	47.7	
	67	THC	51.8	51.8	51.8	50.2	50.2	50.2	47.0	47.0	47.0	43.3	43.3	45.2	
		SHC	30.3	38.3	46.2	30.3	38.8	47.2	29.3	37.9	46.5	27.9	36.5	45.2	
	72	THC	53.0	53.0	53.0	52.7	52.7	52.7	51.3	51.3	51.3	48.4	48.4	48.4	
		SHC	20.9	28.2	35.5	21.0	28.8	36.5	20.6	28.8	37.1	19.7	28.2	36.7	
	76	THC	-	53.7	53.7	-	53.7	53.7	-	52.7	52.7	-	50.7	50.7	
		SHC	-	22.0	30.8	-	22.0	30.5	-	21.6	30.1	-	21.0	29.6	
2000 Cfm	EAT (wb)	58	THC	49.4	49.4	55.9	47.3	47.3	53.5	44.6	44.6	50.4	41.8	41.8	47.4
		SHC	42.9	49.4	55.9	41.0	47.3	53.5	38.7	44.6	50.4	36.3	41.8	47.4	
	62	THC	49.8	49.8	57.6	48.1	48.1	52.2	44.6	44.6	52.5	41.9	41.9	49.3	
		SHC	40.5	49.0	57.6	37.3	44.8	52.2	36.7	44.6	52.5	34.5	41.9	49.3	
	67	THC	52.0	52.0	52.0	50.8	50.8	50.8	47.7	47.7	49.4	44.0	44.0	48.2	
		SHC	30.9	39.4	47.8	31.4	40.5	49.7	30.6	40.0	49.4	29.3	38.7	48.2	
	72	THC	53.1	53.1	53.1	52.9	52.9	52.9	51.6	51.6	51.6	48.9	48.9	48.9	
		SHC	21.0	28.6	36.2	21.0	29.3	37.5	20.8	29.6	38.5	20.0	29.3	38.5	
	76	THC	-	53.8	53.8	-	53.8	53.8	-	52.9	52.9	-	51.0	51.0	
		SHC	-	22.1	31.2	-	22.1	31.1	-	21.8	30.8	-	21.3	30.4	

LEGEND

- Do not operate in this region (Points are outside SST and SDT permissible operating range)
- Cfm - Cubic feet per minute (supply air)
- EAT(db) - Entering air temperature (dry bulb)
- EAT(wb) - Entering air temperature (wet bulb)
- SHC - Sensible heat capacity
- THC - Total capacity

Table 14 – COOLING CAPACITIES

1-STAGE COOLING

5 TONS

50KCQA06			Ambient Temperature												
			85			95			105			115			
			EA (dB)			EA (dB)			EA (dB)			EA (dB)			
			75	80	85	75	80	85	75	80	85	75	80	85	
1500 Cfm	EAT (wb)	58	THC	51.1	51.1	57.8	48.9	48.9	55.3	46.4	46.4	52.5	43.5	43.5	49.2
		SHC	44.3	51.1	57.8	42.4	48.9	55.3	40.2	46.4	52.5	37.7	43.5	49.2	
	62	THC	53.5	53.5	55.7	50.7	50.7	54.3	47.5	47.5	52.7	44.6	44.6	48.5	
		SHC	40.3	48.0	55.7	39.0	46.7	54.3	37.5	45.1	52.7	34.6	41.6	48.5	
	67	THC	59.1	59.1	59.1	56.1	56.1	56.1	52.8	52.8	52.8	48.9	48.9	48.9	
		SHC	33.1	40.9	48.6	31.9	39.6	47.3	30.5	38.2	45.9	28.9	36.6	44.4	
	72	THC	65.4	65.4	65.4	62.3	62.3	62.3	58.6	58.6	58.6	54.7	54.7	54.7	
		SHC	25.7	33.5	41.3	24.6	32.4	40.2	23.2	30.9	38.7	21.7	29.4	37.2	
	76	THC	-	70.1	70.1	-	67.2	67.2	-	63.9	63.9	-	60.3	60.3	
		SHC	-	27.4	35.7	-	26.4	34.5	-	25.1	33.1	-	23.9	31.8	
1750 Cfm	EAT (wb)	58	THC	53.9	53.9	61.1	51.6	51.6	58.5	49.0	49.0	55.5	46.2	46.2	52.3
		SHC	46.8	53.9	61.1	44.8	51.6	58.5	42.5	49.0	55.5	40.1	46.2	52.3	
	62	THC	53.3	53.3	57.6	50.3	50.3	55.9	47.1	47.1	54.1	44.6	44.6	49.1	
		SHC	41.2	49.4	57.6	39.7	47.8	55.9	38.1	46.1	54.1	35.0	42.0	49.1	
	67	THC	61.4	61.4	61.4	57.8	57.8	57.8	54.3	54.3	54.3	50.7	50.7	50.7	
		SHC	35.3	44.3	53.2	33.9	42.8	51.7	32.5	41.4	50.3	31.0	40.0	48.9	
	72	THC	67.5	67.5	67.5	64.1	64.1	64.1	60.4	60.4	60.4	56.6	56.6	56.6	
		SHC	26.6	35.5	44.5	25.4	34.3	43.3	24.0	33.0	42.0	22.6	31.5	40.5	
	76	THC	-	72.0	72.0	-	68.8	68.8	-	65.4	65.4	-	61.8	61.8	
		SHC	-	28.4	37.7	-	27.3	36.5	-	26.1	35.2	-	24.8	33.9	
2000 Cfm	EAT (wb)	58	THC	56.6	56.6	64.1	53.9	53.9	61.0	51.2	51.2	57.9	48.3	48.3	54.7
		SHC	49.1	56.6	64.1	46.8	53.9	61.0	44.4	51.2	57.9	41.9	48.3	54.7	
	62	THC	54.7	54.7	61.8	52.1	52.1	57.3	49.6	49.6	53.0	45.9	45.9	54.0	
		SHC	43.7	52.7	61.8	40.8	49.1	57.3	38.1	45.5	53.0	37.8	45.9	54.0	
	67	THC	60.2	60.2	60.2	56.8	56.8	56.8	53.4	53.4	53.4	49.8	49.8	49.8	
		SHC	35.3	44.6	53.8	33.9	43.2	52.5	32.6	41.8	51.1	31.2	40.5	49.7	
	72	THC	68.8	68.8	68.8	65.4	65.4	65.4	61.7	61.7	61.7	57.8	57.8	57.8	
		SHC	27.2	37.2	47.2	26.0	36.1	46.1	24.7	34.8	44.9	23.3	33.4	43.5	
	76	THC	-	73.0	73.0	-	69.9	69.9	-	66.5	66.5	-	62.9	62.9	
		SHC	-	29.0	39.3	-	28.0	38.3	-	26.8	37.1	-	25.6	35.9	
2250 Cfm	EAT (wb)	58	THC	58.7	58.7	66.5	55.9	55.9	63.3	53.0	53.0	60.0	50.1	50.1	56.7
		SHC	51.0	58.7	66.5	48.5	55.9	63.3	46.0	53.0	60.0	43.5	50.1	56.7	
	62	THC	59.6	59.6	66.1	56.7	56.7	62.7	53.1	53.1	62.4	50.1	50.1	59.0	
		SHC	47.0	56.5	66.1	44.6	53.6	62.7	43.7	53.1	62.4	41.3	50.1	59.0	
	67	THC	63.9	63.9	63.9	60.1	60.1	60.1	56.3	56.3	58.4	52.6	52.6	56.9	
		SHC	39.0	50.1	61.3	37.6	48.7	59.9	36.1	47.3	58.4	34.7	45.8	56.9	
	72	THC	69.9	69.9	69.9	66.4	66.4	66.4	62.7	62.7	62.7	58.8	58.8	58.8	
		SHC	27.8	38.8	49.8	26.6	37.7	48.8	25.3	36.5	47.7	24.0	35.2	46.5	
	76	THC	-	73.5	73.5	-	70.8	70.8	-	67.3	67.3	-	63.7	63.7	
		SHC	-	29.5	40.7	-	28.6	39.9	-	27.5	38.8	-	26.3	37.6	
2500 Cfm	EAT (wb)	58	THC	60.6	60.6	68.6	57.6	57.6	65.2	54.6	54.6	61.8	51.6	51.6	58.4
		SHC	52.6	60.6	68.6	50.0	57.6	65.2	47.4	54.6	61.8	44.8	51.6	58.4	
	62	THC	61.0	61.0	70.4	57.6	57.6	67.8	54.7	54.7	64.3	51.7	51.7	60.8	
		SHC	49.5	60.0	70.4	47.4	57.6	67.8	45.0	54.7	64.3	42.5	51.7	60.8	
	67	THC	64.8	64.8	65.0	61.0	61.0	63.9	57.1	57.1	62.2	53.3	53.3	60.6	
		SHC	40.6	52.8	65.0	39.3	51.6	63.9	37.8	50.0	62.2	36.4	48.5	60.6	
	72	THC	70.7	70.7	70.7	67.2	67.2	67.2	63.5	63.5	63.5	59.5	59.5	59.5	
		SHC	28.2	40.2	52.3	27.0	39.2	51.3	25.8	38.1	50.4	24.5	36.9	49.2	
	76	THC	-	73.8	73.8	-	71.5	71.5	-	68.0	68.0	-	64.3	64.3	
		SHC	-	29.8	41.8	-	29.2	41.4	-	28.1	40.3	-	26.9	39.2	

50KCG



LEGEND

- Do not operate in this region (Points are outside SST and SDT permissible operating range)
- Cfm - Cubic feet per minute (supply air)
- EAT(db) - Entering air temperature (dry bulb)
- EAT(wb) - Entering air temperature (wet bulb)
- SHC - Sensible heat capacity
- THC - Total capacity

Table 15 – HEATING CAPACITIES

3 TONS

50KCA

		50KCQA04									
RETURN AIR (°F db)	CFM (STANDARD AIR)		TEMPERATURE AIR ENTERING OUTDOOR COIL (°F db AT 70% RH)								
			-10	0	10	17	30	40	47	50	60
55	900	Capacity	9.3	12.8	16.6	19.4	26.4	31.0	34.8	36.4	42.3
		Int. Cap.	8.6	11.8	15.2	17.7	23.1	31.0	34.8	36.4	42.3
	1200	Capacity	9.5	13.3	17.1	20.1	27.7	32.4	36.3	37.9	43.9
		Int. Cap.	8.8	12.3	15.7	18.3	24.3	32.4	36.3	37.9	43.9
	1500	Capacity	10.2	13.8	18.0	21.0	27.3	32.7	36.4	38.2	43.3
		Int. Cap.	9.4	12.7	16.5	19.1	23.9	32.7	36.4	38.2	43.3
70	900	Capacity	6.7	10.3	14.2	16.9	23.2	28.1	32.3	34.0	40.0
		Int. Cap.	6.2	9.5	13.1	15.4	20.3	28.1	32.3	34.0	40.0
	1200	Capacity	7.3	11.1	15.1	18.1	24.6	29.9	34.1	35.8	41.7
		Int. Cap.	6.7	10.2	13.8	16.5	21.5	29.9	34.1	35.8	41.7
	1500	Capacity	7.7	11.7	15.5	18.8	26.0	31.1	35.0	36.8	42.7
		Int. Cap.	7.1	10.7	14.3	17.1	22.8	31.1	35.0	36.8	42.7
80	900	Capacity	4.9	8.6	12.3	15.5	21.4	26.4	30.0	31.8	40.7
		Int. Cap.	4.5	7.9	11.3	14.1	18.8	26.4	30.0	31.8	40.7
	1200	Capacity	5.4	9.1	13.1	16.2	22.8	27.9	32.2	34.1	40.1
		Int. Cap.	5.0	8.4	12.1	14.7	20.0	27.9	32.2	34.1	40.1
	1500	Capacity	5.8	9.7	13.9	16.8	23.6	28.8	33.4	35.1	41.1
		Int. Cap.	5.4	8.9	12.8	15.3	20.6	28.8	33.4	35.1	41.1

LEGEND

- Capacity – Instantaneous Capacity (1000 Btuh) includes indoor fan motor heat @AHRI static conditions
- Int. Cap. – Integrated Capacity is Instantaneous Capacity minus the effects of frost on the outdoor coil and the heat required to defrost
- RH – Relative Humidity
- db – Dry Bulb

Table 16 – HEATING CAPACITIES

4 TONS

		50KCQA05									
RETURN AIR (°F db)	CFM (STANDARD AIR)		TEMPERATURE AIR ENTERING OUTDOOR COIL (°F db AT 70% RH)								
			-10	0	10	17	30	40	47	50	60
55	1200	Capacity	17.8	22.3	27.5	31.0	40.0	45.9	51.1	53.4	61.2
		Int. Cap.	16.5	20.5	25.2	28.3	35.0	45.9	51.1	53.4	61.2
	1600	Capacity	23.0	23.0	28.2	31.9	40.2	47.2	52.5	54.6	61.4
		Int. Cap.	21.3	21.2	25.8	29.0	35.3	47.2	52.5	54.6	61.4
	2000	Capacity	18.8	23.7	28.8	32.5	41.0	47.9	52.5	54.4	60.8
		Int. Cap.	17.4	21.8	26.4	29.7	35.9	47.9	52.5	54.4	60.8
70	1200	Capacity	16.2	20.6	25.6	29.4	36.4	42.9	48.4	50.7	58.8
		Int. Cap.	15.0	18.9	23.5	26.8	31.9	42.9	48.4	50.7	58.8
	1600	Capacity	16.9	21.3	26.8	30.3	37.6	44.8	49.9	52.3	59.8
		Int. Cap.	15.6	19.6	24.6	27.6	32.9	44.8	49.9	52.3	59.8
	2000	Capacity	17.4	22.0	27.5	31.0	38.8	45.7	50.8	52.9	59.7
		Int. Cap.	16.1	20.2	25.2	28.3	34.0	45.7	50.8	52.9	59.7
80	1200	Capacity	14.6	19.1	23.9	28.2	35.0	41.0	46.2	48.6	56.9
		Int. Cap.	13.5	17.6	21.9	25.7	30.7	41.0	46.2	48.6	56.9
	1600	Capacity	15.4	19.8	25.0	29.2	36.3	42.7	48.2	50.5	58.4
		Int. Cap.	14.2	18.3	23.0	26.6	31.8	42.7	48.2	50.5	58.4
	2000	Capacity	16.1	20.7	25.9	29.9	37.2	43.8	49.1	51.4	58.6
		Int. Cap.	14.9	19.0	23.7	27.3	32.6	43.8	49.1	51.4	58.6

LEGEND

- Capacity – Instantaneous Capacity (1000 Btuh) includes indoor fan motor heat @AHRI static conditions
- Int. Cap. – Integrated Capacity is Instantaneous Capacity minus the effects of frost on the outdoor coil and the heat required to defrost
- RH – Relative Humidity
- db – Dry Bulb

Table 17 – HEATING CAPACITY

5 TONS

50KCQA06											
RETURN AIR (°F db)	CFM (STANDARD AIR)		TEMPERATURE AIR ENTERING OUTDOOR COIL (°F db AT 70% RH)								
			-10	0	10	17	30	40	47	50	60
55	1500	Capacity	17.7	23.0	28.8	33.0	42.4	49.8	55.6	58.3	67.5
		Int. Cap.	16.4	21.2	26.4	30.1	37.2	49.8	55.6	58.3	67.5
	2000	Capacity	18.7	24.1	29.9	34.3	44.7	52.4	58.4	61.0	69.7
		Int. Cap.	17.3	22.1	27.5	31.3	39.2	52.4	58.4	61.0	69.7
	2500	Capacity	19.6	25.0	31.1	35.7	44.5	52.3	57.6	59.8	67.0
		Int. Cap.	18.1	23.0	28.6	32.6	39.0	52.3	57.6	59.8	67.0
70	1500	Capacity	15.0	20.4	26.1	30.3	40.4	48.5	54.0	56.6	65.7
		Int. Cap.	13.8	18.8	23.9	27.6	35.4	48.5	54.0	56.6	65.7
	2000	Capacity	15.9	21.5	27.2	31.6	44.2	50.2	55.9	58.6	67.6
		Int. Cap.	14.7	19.8	25.0	28.8	38.7	50.2	55.9	58.6	67.6
	2500	Capacity	16.8	22.5	28.5	32.9	43.9	51.5	57.3	59.9	68.0
		Int. Cap.	15.6	20.7	26.2	30.0	38.5	51.5	57.3	59.9	68.0
80	1500	Capacity	12.9	18.5	24.5	28.8	38.3	46.7	52.1	54.6	63.5
		Int. Cap.	11.9	17.0	22.5	26.3	33.6	46.7	52.1	54.6	63.5
	2000	Capacity	13.8	19.6	25.6	30.0	38.6	47.1	52.6	55.2	63.7
		Int. Cap.	12.8	18.0	23.5	27.3	33.9	47.1	52.6	55.2	63.7
	2500	Capacity	14.8	20.6	26.9	31.3	41.5	49.9	55.6	58.2	66.6
		Int. Cap.	13.7	19.0	24.7	28.6	36.4	49.9	55.6	58.2	66.6

50KCA

LEGEND

- Capacity – Instantaneous Capacity (1000 Btuh) includes indoor fan motor heat @AHRI static conditions
- Int. Cap. – Integrated Capacity is Instantaneous Capacity minus the effects of frost on the outdoor coil and the heat required to defrost
- RH – Relative Humidity
- db – Dry Bulb



Table 18 – STATIC PRESSURE ADDERS (FACTORY OPTIONS AND/OR ACCESSORIES)

3-5 TONS										
CFM	600	900	1200	1400	1600	1800	2000	2200	2400	2600
1 Electric Heater Module	0.03	0.05	0.07	0.09	0.09	0.10	0.11	0.11	0.12	0.13
2 Electric Heater Modules	0.13	0.15	0.16	0.16	0.16	0.17	0.17	0.17	0.18	0.18

3-5-TONS										
CFM	600	800	1000	1250	1500	1750	2000	2250	2500	
Vertical Economizer	0.012	0.020	0.030	0.046	0.066	0.089	0.115	0.145	0.179	
Horizontal Economizer	0.018	0.026	0.037	0.053	0.073	0.096	0.124	0.154	0.189	

All above data for both standard and ultra low leak models, where available.

3-5-TONS						
Power Exhaust Performance						
Return Duct Static Pressure (in wg)	0.0	0.1	0.2	0.3	0.4	0.5
Vertical Power Exhaust CFM	3239	2974	2642	2244	1780	1249

GENERAL FAN PERFORMANCE NOTES

1. Interpolation is permissible. Do not extrapolate.
2. External static pressure is the static pressure difference between the return duct and the supply duct plus the static pressure caused by any FIOPs or accessories.
3. Tabular data accounts for pressure loss due to clean filters, unit casing, and wet coils. Factory options and accessories may add static pressure losses, as shown in Table 18. Selection software is available, through your salesperson, to help you select the best motor/drive combination for your application.
4. The Fan Performance tables offer motor/drive recommendations. In cases when two motor/drive combinations would work, Carrier recommended the lower horsepower option.
5. For information on the electrical properties of Carrier motors, please see the Electrical information section of this book.
6. For more information on the performance limits of Carrier motors, see the application data section of this book.

FAN PERFORMANCE (DIRECT DRIVE)

Table 19 – 50KCQ-04 Vertical Unit - Direct Drive

Speed (Torque) tap	CFM	ESP	BHP
1	900	0.44	0.19
	975	0.34	0.18
	1050	0.24	0.17
	1125	0.15	0.16
	1200	0.07	0.16
	1275	–	–
	1350	–	–
	1425	–	–
	1500	–	–
2	900	0.60	0.24
	975	0.49	0.23
	1050	0.38	0.22
	1125	0.28	0.21
	1200	0.18	0.20
	1275	0.09	0.19
	1350	–	–
	1425	–	–
	1500	–	–
3	900	0.93	0.36
	975	0.81	0.35
	1050	0.70	0.34
	1125	0.58	0.33
	1200	0.47	0.31
	1275	0.36	0.30
	1350	0.25	0.29
	1425	0.14	0.27
	1500	–	–
4	900	1.15	0.44
	975	1.07	0.45
	1050	0.97	0.46
	1125	0.86	0.46
	1200	0.74	0.43
	1275	0.61	0.41
	1350	0.48	0.40
	1425	0.35	0.39
	1500	0.23	0.37
5	900	1.24	0.51
	975	1.19	0.52
	1050	1.24	0.54
	1125	1.24	0.57
	1200	1.03	0.59
	1275	0.98	0.61
	1350	0.93	0.64
	1425	0.88	0.67
	1500	0.82	0.69

Table 20 – 50KCQ-04 Horizontal Unit - Direct Drive

Speed (Torque) tap	CFM	ESP	BHP
1	900	0.57	0.25
	975	0.47	0.24
	1050	0.37	0.22
	1125	0.27	0.21
	1200	0.18	0.20
	1275	0.09	0.20
	1350	–	–
	1425	–	–
	1500	–	–
2	900	0.73	0.30
	975	0.62	0.29
	1050	0.51	0.28
	1125	0.41	0.27
	1200	0.30	0.25
	1275	0.19	0.24
	1350	0.08	0.22
	1425	–	–
	1500	–	–
3	900	1.04	0.41
	975	0.93	0.40
	1050	0.82	0.39
	1125	0.70	0.38
	1200	0.58	0.36
	1275	0.46	0.35
	1350	0.34	0.33
	1425	0.23	0.31
	1500	0.12	0.30
4	900	1.26	0.49
	975	1.18	0.50
	1050	1.09	0.50
	1125	0.99	0.50
	1200	0.88	0.49
	1275	0.76	0.47
	1350	0.63	0.46
	1425	0.50	0.44
	1500	0.37	0.42
5	900	1.35	0.52
	975	1.30	0.54
	1050	1.26	0.57
	1125	1.21	0.59
	1200	1.16	0.62
	1275	1.12	0.64
	1350	1.07	0.67
	1425	1.02	0.70
	1500	0.97	0.73

50KCQ

FAN PERFORMANCE (DIRECT DRIVE) (cont.)

Table 21 – 50KCQ-05 Vertical Unit - Direct Drive

Speed (Torque) tap	CFM	ESP	BHP
1	1200	0.87	0.43
	1300	0.73	0.41
	1400	0.59	0.39
	1500	0.43	0.37
	1600	0.27	0.34
	1700	0.12	0.33
	1800	–	–
	1900	–	–
	2000	–	–
2	1200	0.96	0.48
	1300	0.84	0.46
	1400	0.69	0.44
	1500	0.53	0.41
	1600	0.37	0.39
	1700	0.21	0.36
	1800	0.06	0.34
	1900	–	–
	2000	–	–
3	1200	1.13	0.53
	1300	1.06	0.53
	1400	0.98	0.54
	1500	0.88	0.56
	1600	0.76	0.54
	1700	0.62	0.52
	1800	0.47	0.50
	1900	0.31	0.47
	2000	0.15	0.45
4	1200	1.16	0.57
	1300	1.12	0.59
	1400	1.07	0.62
	1500	1.00	0.67
	1600	0.91	0.66
	1700	0.80	0.67
	1800	0.67	0.67
	1900	0.52	0.63
	2000	0.35	0.61
5	1200	1.16	0.59
	1300	1.11	0.63
	1400	1.01	0.67
	1500	0.91	0.67
	1600	0.96	0.75
	1700	0.91	0.75
	1800	0.86	0.83
	1900	0.80	0.87
	2000	0.74	0.91

Table 22 – 50KCQ-05 Horizontal Unit - Direct Drive

Speed (Torque) tap	CFM	ESP	BHP
1	1200	0.93	0.48
	1300	0.80	0.46
	1400	0.66	0.44
	1500	0.51	0.41
	1600	0.36	0.39
	1700	0.22	0.36
	1800	0.08	0.33
	1900	–	–
	2000	–	–
2	1200	1.04	0.53
	1300	0.91	0.51
	1400	0.76	0.48
	1500	0.61	0.46
	1600	0.45	0.43
	1700	0.30	0.40
	1800	0.16	0.38
	1900	0.04	0.35
	2000	–	–
3	1200	1.18	0.58
	1300	1.09	0.59
	1400	0.98	0.60
	1500	0.86	0.60
	1600	0.72	0.57
	1700	0.57	0.54
	1800	0.42	0.51
	1900	0.28	0.48
	2000	0.15	0.45
4	1200	1.24	0.60
	1300	1.18	0.63
	1400	1.12	0.66
	1500	1.04	0.71
	1600	0.95	0.70
	1700	0.85	0.71
	1800	0.73	0.71
	1900	0.60	0.69
	2000	0.45	0.65
5	1200	1.25	0.61
	1300	1.20	0.65
	1400	1.12	0.68
	1500	1.04	0.68
	1600	1.05	0.76
	1700	1.01	0.76
	1800	0.96	0.84
	1900	0.91	0.89
	2000	0.87	0.93

50KCQ

FAN PERFORMANCE (DIRECT DRIVE) (cont.)

Table 23 – 50KCQ-06 Vertical Unit - Direct Drive

Speed (Torque) tap	CFM	ESP	BHP
1	1500	0.27	0.32
	1625	0.13	0.30
	1750	–	–
	1875	–	–
	2000	–	–
	2125	–	–
	2250	–	–
	2375	–	–
	2500	–	–
2	1500	0.42	0.40
	1625	0.25	0.37
	1750	0.08	0.34
	1875	–	–
	2000	–	–
	2125	–	–
	2250	–	–
	2375	–	–
	2500	–	–
3	1500	1.11	0.79
	1625	0.91	0.76
	1750	0.70	0.74
	1875	0.50	0.70
	2000	0.30	0.67
	2125	0.12	0.63
	2250	–	–
	2375	–	–
	2500	–	–
4	1500	1.29	0.90
	1625	1.13	0.88
	1750	0.95	0.91
	1875	0.74	0.88
	2000	0.52	0.84
	2125	0.30	0.80
	2250	0.11	0.77
	2375	–	–
	2500	–	–
5	1500	1.36	0.94
	1625	1.24	0.99
	1750	0.95	1.02
	1875	0.74	1.05
	2000	0.74	1.03
	2125	0.53	0.99
	2250	0.31	0.94
	2375	0.08	0.90
	2500	–	0.86

Table 24 – 50KCQ-06 Horizontal Unit - Direct Drive

Speed (Torque) tap	CFM	ESP	BHP
1	1500	0.37	0.35
	1625	0.22	0.33
	1750	0.08	0.31
	1875	–	–
	2000	–	–
	2125	–	–
	2250	–	–
	2375	–	–
	2500	–	–
2	1500	0.54	0.44
	1625	0.37	0.41
	1750	0.20	0.38
	1875	0.04	0.35
	2000	–	–
	2125	–	–
	2250	–	–
	2375	–	–
	2500	–	–
3	1500	1.28	0.83
	1625	1.10	0.81
	1750	0.90	0.78
	1875	0.68	0.74
	2000	0.47	0.70
	2125	0.27	0.66
	2250	0.10	0.62
	2375	–	–
	2500	–	–
4	1500	1.46	0.94
	1625	1.32	0.92
	1750	1.16	0.96
	1875	0.96	0.95
	2000	0.76	0.91
	2125	0.54	0.86
	2250	0.33	0.82
	2375	0.14	0.78
	2500	0.00	0.72
5	1500	1.52	0.97
	1625	1.42	1.01
	1750	1.16	1.05
	1875	0.96	1.09
	2000	1.00	1.09
	2125	0.82	1.06
	2250	0.62	1.02
	2375	0.40	0.98
	2500	0.16	0.93

50KCQ

FAN PERFORMANCE - BELT DRIVE

Table 25 – 50KCQA04

3 TON VERTICAL SUPPLY

CFM	AVAILABLE EXTERNAL STATIC PRESSURE (IN. WG)									
	0.2		0.4		0.6		0.8		1.0	
	RPM	BHP	RPM	BHP	RPM	BHP	RPM	BHP	RPM	BHP
900	594	0.15	740	0.25	867	0.37	981	0.52	1084	0.68
975	618	0.17	758	0.28	881	0.40	991	0.55	1092	0.71
1050	642	0.19	777	0.30	896	0.43	1003	0.58	1102	0.75
1125	668	0.22	797	0.34	912	0.47	1017	0.62	1113	0.79
1200	695	0.25	818	0.37	930	0.51	1032	0.66	1126	0.83
1275	722	0.29	841	0.41	949	0.55	1048	0.71	1140	0.88
1350	750	0.33	864	0.46	968	0.60	1065	0.76	1155	0.93
1425	778	0.37	888	0.50	989	0.65	1083	0.81	1171	0.99
1500	807	0.42	913	0.56	1011	0.71	1103	0.87	1188	1.05

CFM	AVAILABLE EXTERNAL STATIC PRESSURE (IN. WG)									
	1.2		1.4		1.6		1.8		2.0	
	RPM	BHP	RPM	BHP	RPM	BHP	RPM	BHP	RPM	BHP
900	1180	0.86	1269	1.05	1354	1.25	1434	1.47	1511	1.70
975	1186	0.89	1275	1.08	1358	1.29	1437	1.51	1513	1.74
1050	1194	0.92	1281	1.12	1363	1.32	1441	1.54	1516	1.78
1125	1204	0.97	1289	1.16	1370	1.37	1447	1.59	1520	1.82
1200	1215	1.01	1298	1.21	1378	1.42	1454	1.64	1526	1.87
1275	1227	1.06	1309	1.26	1387	1.47	1462	1.69	1533	1.92
1350	1240	1.12	1321	1.32	1397	1.53	1471	1.75	1541	1.99
1425	1254	1.18	1333	1.38	1409	1.59	1481	1.82	–	–
1500	1270	1.24	1347	1.45	1421	1.66	1492	1.89	–	–

Med static – 819–1251 RPM, Max BHP 1.5

High static – 1035–1466 RPM, Max BHP 2.0

Bold Face indicates field-supplied drive

Recommend using field-supplied fan pulley (part no. KR11AD561), motor pulley (part no. KR11HY181) and belt (part no. KR29AF041).

Table 26 – 50KCQA04

3 TON HORIZONTAL SUPPLY

CFM	AVAILABLE EXTERNAL STATIC PRESSURE (IN. WG)									
	0.2		0.4		0.6		0.8		1.0	
	RPM	BHP	RPM	BHP	RPM	BHP	RPM	BHP	RPM	BHP
900	574	0.13	707	0.23	817	0.34	913	0.47	999	0.61
975	597	0.15	727	0.25	835	0.37	929	0.50	1015	0.64
1050	621	0.18	747	0.28	853	0.40	946	0.53	1030	0.68
1125	646	0.20	768	0.31	872	0.43	964	0.57	1047	0.72
1200	671	0.23	790	0.34	892	0.47	982	0.61	1064	0.76
1275	696	0.26	812	0.38	912	0.51	1001	0.65	1082	0.81
1350	723	0.30	835	0.42	933	0.55	1020	0.70	1100	0.86
1425	749	0.34	859	0.46	955	0.60	1040	0.75	1119	0.91
1500	776	0.38	883	0.51	977	0.65	1061	0.80	1138	0.97

CFM	AVAILABLE EXTERNAL STATIC PRESSURE (IN. WG)									
	1.2		1.4		1.6		1.8		2.0	
	RPM	BHP	RPM	BHP	RPM	BHP	RPM	BHP	RPM	BHP
900	1078	0.77	1151	0.93	1220	1.11	1284	1.30	1346	1.49
975	1093	0.80	1165	0.97	1233	1.15	1297	1.33	1358	1.53
1050	1108	0.84	1180	1.01	1247	1.19	1311	1.38	1371	1.58
1125	1123	0.88	1195	1.05	1261	1.23	1325	1.42	1385	1.62
1200	1140	0.92	1210	1.10	1276	1.28	1339	1.47	1399	1.68
1275	1157	0.97	1226	1.15	1292	1.33	1354	1.53	1414	1.73
1350	1174	1.02	1243	1.20	1308	1.39	1370	1.59	1429	1.80
1425	1192	1.08	1260	1.26	1325	1.45	1386	1.65	1444	1.86
1500	1210	1.14	1278	1.33	1342	1.52	1403	1.72	1461	1.93

Med static – 819–1251 RPM, Max BHP 1.5

High static – 1035–1466 RPM, Max BHP 2.0

50KCQA

FAN PERFORMANCE - BELT DRIVE (cont.)

Table 27 – 50KCQA05

4 TON VERTICAL SUPPLY

CFM	AVAILABLE EXTERNAL STATIC PRESSURE (IN. WG)									
	0.2		0.4		0.6		0.8		1.0	
	RPM	BHP	RPM	BHP	RPM	BHP	RPM	BHP	RPM	BHP
1200	682	0.25	800	0.36	897	0.48	982	0.61	1058	0.75
1300	717	0.29	832	0.42	928	0.55	1011	0.68	1086	0.82
1400	753	0.34	865	0.48	956	0.61	1041	0.76	1115	0.91
1500	789	0.40	898	0.54	990	0.69	1071	0.84	1144	1.00
1600	826	0.47	932	0.62	1022	0.77	1102	0.93	1175	1.09
1700	863	0.54	966	0.70	1055	0.86	1133	1.03	1205	1.20
1800	901	0.62	1001	0.79	1088	0.96	1165	1.13	1235	1.31
1900	939	0.71	1037	0.89	1121	1.07	1197	1.25	1267	1.44
2000	978	0.81	1073	0.99	1156	1.18	1230	1.37	1299	1.57

CFM	AVAILABLE EXTERNAL STATIC PRESSURE (IN. WG)									
	1.2		1.4		1.6		1.8		2.0	
	RPM	BHP	RPM	BHP	RPM	BHP	RPM	BHP	RPM	BHP
1200	1128	0.89	1192	1.03	1252	1.18	1309	1.34	1363	1.50
1300	1155	0.97	1219	1.12	1279	1.28	1336	1.44	1389	1.61
1400	1183	1.06	1247	1.22	1306	1.38	1362	1.55	1416	1.72
1500	1212	1.16	1275	1.32	1334	1.49	1389	1.67	1443	1.85
1600	1241	1.26	1303	1.43	1362	1.61	1417	1.79	1470	1.98
1700	1271	1.37	1332	1.55	1390	1.74	1445	1.93	1498	2.12
1800	1301	1.50	1362	1.68	1419	1.87	1474	2.07	1526	2.27
1900	1331	1.63	1392	1.82	1449	2.02	1503	2.22	–	–
2000	1362	1.77	1422	1.97	1478	2.18	1532	2.38	–	–

Med static – 920–1303 RPM, Max BHP 1.5

High static – 1035–1466 RPM, Max BHP 2.0

ITALICS – indicates field-supplied motor and drive required, recommend using field supplied motor (HD58FE651–230v and 460v, HD58FE576–575 volt), fan pulley (part no. KR11AZ606), motor pulley (part no. KR11HY213), and belt (KR29AF043)

Table 28 – 50KCQA05

4 TON HORIZONTAL SUPPLY

CFM	AVAILABLE EXTERNAL STATIC PRESSURE (IN. WG)									
	0.2		0.4		0.6		0.8		1.0	
	RPM	BHP	RPM	BHP	RPM	BHP	RPM	BHP	RPM	BHP
1200	630	0.20	755	0.31	859	0.43	949	0.56	1030	0.70
1300	659	0.24	781	0.36	883	0.48	972	0.61	1052	0.76
1400	689	0.28	808	0.40	908	0.53	995	0.67	1075	0.82
1500	720	0.33	836	0.46	933	0.59	1020	0.74	1098	0.89
1600	752	0.38	864	0.52	960	0.66	1044	0.81	1121	0.97
1700	784	0.44	893	0.58	986	0.73	1070	0.89	1146	1.05
1800	816	0.50	922	0.65	1014	0.81	1096	0.97	1171	1.14
1900	849	0.58	952	0.73	1042	0.90	1122	1.07	1196	1.24
2000	882	0.66	982	0.82	1070	0.99	1149	1.17	1222	1.35

CFM	AVAILABLE EXTERNAL STATIC PRESSURE (IN. WG)									
	1.2		1.4		1.6		1.8		2.0	
	RPM	BHP	RPM	BHP	RPM	BHP	RPM	BHP	RPM	BHP
1200	1104	0.84	1173	0.99	1237	1.15	1298	1.32	1356	1.49
1300	1125	0.91	1194	1.06	1258	1.23	1318	1.40	1375	1.58
1400	1147	0.98	1215	1.14	1278	1.31	1338	1.48	1395	1.67
1500	1170	1.05	1237	1.22	1299	1.39	1359	1.57	1416	1.76
1600	1193	1.13	1259	1.31	1321	1.49	1380	1.67	1437	1.86
1700	1216	1.22	1282	1.40	1344	1.59	1402	1.78	1458	1.97
1800	1240	1.32	1305	1.50	1366	1.69	1424	1.89	1480	2.09
1900	1265	1.43	1329	1.61	1390	1.81	1447	2.01	1502	2.22
2000	1290	1.54	1353	1.73	1413	1.93	1470	2.14	1525	2.35

Med static – 920–1303 RPM, Max BHP 1.5

High static – 1035–1466 RPM, Max BHP 2.0

ITALICS – indicates field-supplied motor and drive required, recommend using field supplied motor (HD58FE651–230v and 460v, HD58FE576–575 volt), fan pulley (part no. KR11AZ606), motor pulley (part no. KR11HY213), and belt (KR29AF043)

50KCQA

FAN PERFORMANCE - BELT DRIVE (cont.)

Table 29 – 50KCQA06

5 TON VERTICAL SUPPLY

CFM	AVAILABLE EXTERNAL STATIC PRESSURE (IN. WG)									
	0.2		0.4		0.6		0.8		1.0	
	RPM	BHP	RPM	BHP	RPM	BHP	RPM	BHP	RPM	BHP
1500	794	0.41	902	0.55	993	0.69	1074	0.85	1147	1.00
1625	840	0.49	945	0.64	1034	0.80	1113	0.96	1185	1.13
1750	888	0.59	988	0.75	1075	0.92	1153	1.09	1223	1.26
1875	936	0.70	1033	0.87	1117	1.05	1193	1.23	1263	1.41
2000	984	0.82	1078	1.00	1160	1.19	1235	1.39	1303	1.58
2125	1033	0.96	1124	1.15	1204	1.35	1277	1.56	1343	1.76
2250	1083	1.11	1170	1.32	1248	1.53	1319	1.74	1385	1.96
2375	1133	1.28	1217	1.50	1293	1.72	1363	1.95	1427	2.17
2500	1183	1.47	1265	1.70	1339	1.93	1406	2.17	1470	2.41

CFM	AVAILABLE EXTERNAL STATIC PRESSURE (IN. WG)									
	1.2		1.4		1.6		1.8		2.0	
	RPM	BHP	RPM	BHP	RPM	BHP	RPM	BHP	RPM	BHP
1500	1214	1.16	1277	1.33	1336	1.50	1392	1.67	1445	1.85
1625	1251	1.30	1313	1.47	1371	1.65	1427	1.83	1479	2.02
1750	1289	1.44	1350	1.63	1407	1.81	1462	2.01	1514	2.20
1875	1327	1.60	1387	1.80	1444	1.99	1498	2.19	1550	2.40
2000	1366	1.78	1426	1.98	1482	2.19	1535	2.40	1586	2.61
2125	1406	1.97	1464	2.18	1520	2.40	1573	2.62	1623	2.84
2250	1446	2.18	1504	2.40	1559	2.62	1611	2.85	-	-
2375	1487	2.40	1544	2.63	1598	2.87	-	-	-	-
2500	1529	2.64	1585	2.89	-	-	-	-	-	-

Med static – 1066 – 1380 RPM, Max BHP 2.0

High static – 1208 – 1639 RPM, Max BHP 2.9

Table 30 – 50KCQA06

5 TON HORIZONTAL SUPPLY

CFM	AVAILABLE EXTERNAL STATIC PRESSURE (IN. WG)									
	0.2		0.4		0.6		0.8		1.0	
	RPM	BHP	RPM	BHP	RPM	BHP	RPM	BHP	RPM	BHP
1500	725	0.33	840	0.46	937	0.60	1023	0.75	1101	0.90
1625	765	0.40	876	0.54	970	0.68	1054	0.84	1131	1.00
1750	806	0.48	912	0.63	1004	0.78	1087	0.94	1162	1.11
1875	847	0.57	950	0.72	1039	0.88	1120	1.05	1194	1.23
2000	889	0.66	988	0.83	1075	1.00	1154	1.18	1226	1.36
2125	931	0.78	1027	0.95	1112	1.13	1189	1.31	1260	1.50
2250	974	0.90	1067	1.08	1149	1.27	1224	1.46	1294	1.66
2375	1018	1.03	1107	1.23	1187	1.43	1261	1.63	1329	1.84
2500	1061	1.19	1148	1.39	1226	1.59	1297	1.81	1364	2.02

CFM	AVAILABLE EXTERNAL STATIC PRESSURE (IN. WG)									
	1.2		1.4		1.6		1.8		2.0	
	RPM	BHP	RPM	BHP	RPM	BHP	RPM	BHP	RPM	BHP
1500	1172	1.06	1239	1.23	1302	1.40	1361	1.58	1418	1.77
1625	1201	1.16	1267	1.34	1329	1.52	1388	1.71	1444	1.90
1750	1231	1.28	1296	1.46	1358	1.65	1416	1.84	1472	2.04
1875	1262	1.41	1326	1.60	1387	1.79	1445	1.99	1499	2.20
2000	1294	1.55	1357	1.74	1417	1.95	1474	2.15	1528	2.36
2125	1326	1.70	1388	1.90	1447	2.11	1504	2.33	1557	2.55
2250	1359	1.87	1420	2.08	1479	2.29	1534	2.51	1587	2.74
2375	1393	2.05	1453	2.27	1511	2.49	1566	2.72	-	-
2500	1427	2.24	1487	2.47	1543	2.70	-	-	-	-

Med static – 1066 – 1380 RPM, Max BHP 2.0

High static – 1208 – 1639 RPM, Max BHP 2.9

50KCQA



FAN PERFORMANCE - BELT DRIVE (cont.)

Table 31 – PULLEY ADJUSTMENT - BELT DRIVE

UNIT		MOTOR/DRIVE COMBO	MOTOR PULLEY TURNS OPEN										
			0	0.5	1	1.5	2	2.5	3	3.5	4	4.5	5
04	3 phase	Medium Static	1251	1208	1165	1121	1078	1035	992	949	905	862	819
		High Static	1466	1423	1380	1337	1294	1251	1207	1164	1121	1078	1035
Medium Static		1303	1265	1226	1188	1150	1112	1073	1035	997	958	920	
High Static		1466	1423	1380	1337	1294	1251	1207	1164	1121	1078	1035	
05		Medium Static	1380	1349	1317	1286	1254	1223	1192	1160	1129	1097	1066
		High Static	1639	1596	1553	1510	1467	1424	1380	1337	1294	1251	1208

NOTE: Do not adjust pulley further than 5 turns open.

■ – Factory settings

* Do not set motor pulley above 5 turns open for A or AX section belts

** Do not set motor pulley below 1 turn open for B or BX section belts

50KCG



ELECTRICAL INFORMATION

Table 32 – 50KCQA04
SINGLE STAGE COOLING WITH SINGLE SPEED INDOOR FAN MOTOR

V-Ph-Hz	VOLTAGE RANGE		COMP (ea)		OFM (ea)		IFM		
	MIN	MAX	RLA	LRA	WATTS	FLA	TYPE	EFF at Full Load	FLA
208-1-60	187	253	16.6	79	190	1.0	DD-STD	78%	7.4
230-1-60	187	253	16.6	79	190	1.0	DD-STD	78%	7.4
208-3-60	187	253	10.4	73	190	1.0	DD-STD	78%	7.4
					190	1.0	MED	87%	5.2
					190	1.0	HIGH	89%	8.4
230-3-60	187	253	10.4	73	190	1.0	DD-STD	78%	7.4
					190	1.0	MED	87%	4.9
					190	1.0	HIGH	89%	8.3
460-3-60	414	506	5.8	38	190	0.5	DD-STD	78%	4.0
					190	0.5	MED	87%	2.5
					190	0.5	HIGH	89%	4.2
575-3-60	518	633	3.8	37	190	0.5	DD-STD	78%	4.0
					190	0.5	MED	72%	1.6
					190	0.5	HIGH	77%	2.8

50KCQ
Table 33 – 50KCQA05
SINGLE STAGE COOLING WITH SINGLE SPEED INDOOR FAN MOTOR

V-Ph-Hz	VOLTAGE RANGE		COMP (ea)		OFM (ea)		IFM		
	MIN	MAX	RLA	LRA	WATTS	FLA	TYPE	EFF at Full Load	FLA
208-1-60	187	253	21.8	117	325	1.4	DD-STD	78%	7.4
230-1-60	187	253	21.8	117	325	1.4	DD-STD	78%	7.4
208-3-60	187	253	13.7	83	325	1.4	DD-STD	78%	7.4
					325	1.4	MED	87%	5.2
					325	1.4	HIGH	89%	8.4
230-3-60	187	253	13.7	83	325	1.4	DD-STD	78%	7.4
					325	1.4	MED	87%	4.9
					325	1.4	HIGH	89%	8.3
460-3-60	414	506	6.2	41	325	0.8	DD-STD	78%	4.0
					325	0.8	MED	87%	2.5
					325	0.8	HIGH	89%	4.2
575-3-60	518	633	4.8	33	325	0.8	DD-STD	78%	4.0
					325	0.8	MED	72%	1.6
					325	0.8	HIGH	77%	2.8

Table 34 – 50KCQA06
SINGLE STAGE COOLING WITH SINGLE SPEED INDOOR FAN MOTOR

V-Ph-Hz	VOLTAGE RANGE		COMP (ea)		OFM (ea)		IFM		
	MIN	MAX	RLA	LRA	WATTS	FLA	TYPE	EFF at Full Load	FLA
208-1-60	187	253	23.7	153	325	1.4	DD-STD	78%	7.4
230-1-60	187	253	23.7	153	325	1.4	DD-STD	78%	7.4
208-3-60	187	253	15.9	110	325	1.4	DD-STD	78%	7.4
					325	1.4	MED	89%	8.4
					325	1.4	HIGH	89%	8.4
230-3-60	187	253	15.9	110	325	1.4	DD-STD	78%	7.4
					325	1.4	MED	89%	8.3
					325	1.4	HIGH	89%	8.3
460-3-60	414	506	7.0	52	325	0.8	DD-STD	78%	4.0
					325	0.8	MED	89%	4.2
					325	0.8	HIGH	89%	4.2
575-3-60	518	633	5.1	40	325	0.8	DD-STD	78%	4.0
					325	0.8	MED	77%	2.8
					325	0.8	HIGH	77%	2.8

Legend and Notes for Table 35

LEGEND:

- BRKR – Circuit breaker
- CO – Convenient outlet
- DD – Direct drive (indoor fan motor)
- DISC – Disconnect
- FLA – Full load amps
- IFM – Indoor fan motor
- LRA – Locked rotor amps
- MCA – Minimum circuit amps
- MOCB – MAX FUSE or HACR Breaker
- PE – Power exhaust
- PWRD CO – Powered convenient outlet
- UNPWR CO – Unpowered convenient outlet

NOTES:

1. In compliance with NEC requirements for multimotor and combination load equipment (refer to NEC Articles 430 and 440), the overcurrent protective device for the unit shall be fuse or HACR breaker. Canadian units may be fuse or circuit breaker.
2. **Unbalanced 3-Phase Supply Voltage**
Never operate a motor where a phase imbalance in supply voltage is greater than 2%. Use the following formula to determine the percentage of voltage imbalance.

$$\% \text{ Voltage Imbalance} = 100 \times \frac{\text{max voltage deviation from average voltage}}{\text{average voltage}}$$

Example: Supply voltage is 230-3-60



- AB = 224 v
- BC = 231 v
- AC = 226 v

$$\begin{aligned} \text{Average Voltage} &= \frac{(224 + 231 + 226)}{3} = \frac{681}{3} \\ &= 227 \end{aligned}$$

Determine maximum deviation from average voltage.

(AB) $227 - 224 = 3 \text{ v}$

(BC) $231 - 227 = 4 \text{ v}$

(AC) $227 - 226 = 1 \text{ v}$

Maximum deviation is 4 v.

Determine percent of voltage imbalance.

$$\begin{aligned} \% \text{ Voltage Imbalance} &= 100 \times \frac{4}{227} \\ &= 1.76\% \end{aligned}$$

This amount of phase imbalance is satisfactory as it is below the maximum allowable 2%.

IMPORTANT: If the supply voltage phase imbalance is more than 2%, contact your local electric utility company immediately.

50KCA



Table 35 – Unit Wire/Fuse or HACR Breaker Sizing Data (cont)

UNIT	NO M. V.-Ph-HZ	ELEC. HTR			NO C.O. or UNPWR C.O.						w/ PWRD C.O.									
		IFM TYPE	CRHEATER***A00	Nom (kW)	FLA	NO PE.			w/ PE. (pwrdr fr/unit)			NO PE.			w/ PE. (pwrdr fr/unit)					
						MCA	MAX FUSE or HACR BRKR	DISC. SIZE FLA LRA	MCA	MAX FUSE or HACR BRKR	DISC. SIZE FLA LRA	MCA	MAX FUSE or HACR BRKR	DISC. SIZE FLA LRA	MCA	MAX FUSE or HACR BRKR	DISC. SIZE FLA LRA			
50KCA04	DD-STD	NONE	-	-	-	12	15	13	15	13	44	14	20	14	20	45	15	20	16	46
		106A	6.0	7.2	21	25	20	25	21	51	23	51	23	25	23	52	24	25	24	53
		107A	8.8	10.6	25	30	24	30	25	55	28	55	28	30	27	56	29	30	28	57
		108A	11.5	13.8	29	30	28	30	29	58	32	58	32	35	30	59	33	35	31	60
		109A	14.0	16.8	33	35	31	35	32	61	35	61	35	35	34	62	36	40	35	63
460-3-60	MED	NONE	-	-	-	10	15	11	15	11	58	13	15	13	15	59	14	15	14	60
		106A	6.0	7.2	20	20	18	20	20	64	22	65	22	25	21	66	23	25	22	67
		107A	8.8	10.6	24	25	22	25	23	68	26	69	26	30	25	70	27	30	26	71
		108A	11.5	13.8	28	30	26	30	27	71	29	72	30	30	29	73	31	35	30	74
		109A	14.0	16.8	32	35	29	35	31	74	33	75	34	35	32	76	35	35	33	77
575-3-60	HIGH	NONE	-	-	-	12	15	13	15	13	76	15	20	15	20	77	16	20	16	78
		106A	6.0	7.2	21	25	20	25	22	82	24	83	24	25	23	84	25	25	24	85
		107A	8.8	10.6	26	30	24	30	25	86	27	87	28	30	27	88	29	30	28	89
		108A	11.5	13.8	30	30	28	30	29	89	31	90	32	35	30	91	33	35	32	92
		109A	14.0	16.8	33	35	31	35	33	92	34	93	36	40	34	94	37	40	35	95
575-3-60	DD-STD	NONE	-	-	-	10	15	12	15	12	44	11	15	12	15	44	13	15	14	46
		MED	-	-	-	7	15	9	15	9	47	9	15	9	15	47	11	15	11	49
		HIGH	-	-	-	8	15	10	15	10	62	10	15	10	15	62	12	15	12	64

See "Legend and Notes for Table 35 on page 37.

Table 35 – Unit Wire/Fuse or HACR Breaker Sizing Data (cont)

UNIT	NO M. V.-Ph-HZ	IFM TYPE	ELEC. HTR			NO C.O. or UNPWR C.O.						w/ PWRD C.O.															
			CRHEATER***A00	Nom (kW)	FLA	NO PE.		w/ PE. (pwrd fr/unit)		NO PE.		w/ PE. (pwrd fr/unit)		NO PE.		w/ PE. (pwrd fr/unit)											
						MAX FUSE or HACR BRKR	MCA	FLA	LRA	FLA	LRA	MAX FUSE or HACR BRKR	MCA	FLA	LRA	MAX FUSE or HACR BRKR	MCA	FLA	LRA	MAX FUSE or HACR BRKR	MCA	FLA	LRA				
50KCA05	208/230-1-60	DD - STD	NONE	-	-	37	50	37	35	127	38	50	37	129	-	-	-	-	-	-	-	-	-	-	-		
			101A	3.3/4.4	15.9/18.3	56/59	60/60	53/56	143/145	58/61	56/58	60/70	58/61	60/70	145/147	-	-	-	-	-	-	-	-	-	-	-	
			103B	6.5/8.7	31.4/36.3	76/82	80/90	71/77	158/163	78/84	73/79	80/90	78/84	80/90	160/165	-	-	-	-	-	-	-	-	-	-	-	
			102A+102A	9.8/13.0	46.9/54.2	95/104	100/110	89/98	221/235	97/106	91/100	100/110	97/106	100/110	223/237	-	-	-	-	-	-	-	-	-	-	-	-
			103B+103B	13.1/17.4	62.8/72.5	115/127	125/150	107/119	253/272	117/129	110/121	125/150	117/129	125/150	255/274	-	-	-	-	-	-	-	-	-	-	-	-
			104B+104B	15.8/21.0	75.8/87.5	131/146	150/150	122/136	279/302	133/148	125/138	150/150	133/148	150/150	281/304	-	-	-	-	-	-	-	-	-	-	-	-
			NONE	-	-	26	30	26	93	28	40	28	40	28	95	31	40	28	95	31	40	28	95	31	40	28	
			102A	4.9/6.5	13.6/15.6	43/46	50/50	42/44	107/109	45/48	44/46	50/50	45/48	50/50	109/111	48/51	50/60	44/46	109/111	48/51	50/60	44/46	109/111	48/51	50/60	44/46	
			103B	6.5/8.7	18.1/20.9	49/53	50/60	47/50	111/114	51/54	49/52	60/60	51/54	60/60	113/116	54/57	60/60	49/52	113/116	54/57	60/60	49/52	113/116	54/57	60/60	49/52	
			105A	12.0/16.0	33.4/38.5	68/75	70/80	64/70	126/132	70/76	66/72	70/80	70/76	70/80	128/134	73/79	80/80	66/72	128/134	73/79	80/80	66/72	128/134	73/79	80/80	66/72	
104B+104B	15.8/21.0	43.8/50.5	81/90	90/90	76/84	181/194	83/91	78/86	90/100	83/91	90/100	183/196	86/94	90/100	78/86	183/196	86/94	90/100	78/86	183/196	86/94	90/100	78/86				
208/230-3-60	208/230-3-60	MED	NONE	-	-	24/24	30/30	23/23	122	26/26	30/30	26/25	124	29/29	40/40	26/25	124	29/29	40/40	26/25	124	29/29	40/40	26/25			
			102A	4.9/6.5	13.6/15.6	41/43	50/50	39/41	136/138	43/45	41/43	50/50	41/43	138/140	46/48	50/50	41/43	138/140	46/48	50/50	41/43	138/140	46/48	50/50	41/43		
			103B	6.5/8.7	18.1/20.9	47/50	50/50	44/47	140/143	49/52	46/49	50/60	49/52	142/145	52/55	60/60	46/49	142/145	52/55	60/60	46/49	142/145	52/55	60/60	46/49		
			105A	12.0/16.0	33.4/38.5	66/72	70/80	62/67	155/161	68/74	64/69	70/80	68/74	157/163	71/77	80/80	64/69	157/163	71/77	80/80	64/69	157/163	71/77	80/80	64/69		
			104B+104B	15.8/21.0	43.8/50.5	79/87	80/90	74/81	210/223	81/89	76/83	90/90	81/89	90/90	212/225	84/92	90/100	76/83	212/225	84/92	90/100	76/83	212/225	84/92	90/100	76/83	
			NONE	-	-	27/27	40/40	27/27	158	29/29	40/40	29/29	40/40	29/29	160	32/32	45/45	29/29	160	32/32	45/45	29/29	160	32/32	45/45	29/29	
			102A	4.9/6.5	13.6/15.6	44/47	50/50	43/45	172/174	46/49	45/47	50/50	46/49	50/50	174/176	49/52	50/60	45/47	174/176	49/52	50/60	45/47	174/176	49/52	50/60	45/47	
			103B	6.5/8.7	18.1/20.9	50/53	50/60	48/51	176/179	52/55	50/53	60/60	52/55	60/60	178/181	55/58	60/60	50/53	178/181	55/58	60/60	50/53	178/181	55/58	60/60	50/53	
			105A	12.0/16.0	33.4/38.5	69/75	70/80	65/71	191/197	71/77	68/73	80/80	71/77	80/80	193/199	74/80	80/80	68/73	193/199	74/80	80/80	68/73	193/199	74/80	80/80	68/73	
			104B+104B	15.8/21.0	43.8/50.5	82/90	90/90	77/85	246/259	84/92	80/87	90/100	84/92	90/100	248/261	87/95	90/100	80/87	248/261	87/95	90/100	80/87	248/261	87/95	90/100	80/87	
50KCA05	208/230-3-60	HIGH	NONE	-	-	27/27	40/40	27/27	158	29/29	40/40	29/29	160	32/32	45/45	29/29	160	32/32	45/45	29/29	160	32/32	45/45	29/29			
			102A	4.9/6.5	13.6/15.6	44/47	50/50	43/45	172/174	46/49	45/47	50/50	46/49	174/176	49/52	50/60	45/47	174/176	49/52	50/60	45/47	174/176	49/52	50/60	45/47		
			103B	6.5/8.7	18.1/20.9	50/53	50/60	48/51	176/179	52/55	50/53	60/60	52/55	178/181	55/58	60/60	53/56	181/184	57/60	60/60	53/56	181/184	57/60	60/60	53/56		
			105A	12.0/16.0	33.4/38.5	69/75	70/80	65/71	191/197	71/77	68/73	80/80	71/77	193/199	74/80	80/80	71/77	193/199	74/80	80/80	71/77	193/199	74/80	80/80	71/77		
			104B+104B	15.8/21.0	43.8/50.5	82/90	90/90	77/85	246/259	84/92	80/87	90/100	84/92	248/261	87/95	90/100	80/87	248/261	87/95	90/100	80/87	248/261	87/95	90/100	80/87		
			NONE	-	-	27/27	40/40	27/27	158	29/29	40/40	29/29	40/40	29/29	160	32/32	45/45	29/29	160	32/32	45/45	29/29	160	32/32	45/45	29/29	
			102A	4.9/6.5	13.6/15.6	44/47	50/50	43/45	172/174	46/49	45/47	50/50	46/49	50/50	174/176	49/52	50/60	45/47	174/176	49/52	50/60	45/47	174/176	49/52	50/60	45/47	
			103B	6.5/8.7	18.1/20.9	50/53	50/60	48/51	176/179	52/55	50/53	60/60	52/55	60/60	178/181	55/58	60/60	53/56	181/184	57/60	60/60	53/56	181/184	57/60	60/60	53/56	
			105A	12.0/16.0	33.4/38.5	69/75	70/80	65/71	191/197	71/77	68/73	80/80	71/77	80/80	193/199	74/80	80/80	71/77	193/199	74/80	80/80	71/77	193/199	74/80	80/80	71/77	
			104B+104B	15.8/21.0	43.8/50.5	82/90	90/90	77/85	246/259	84/92	80/87	90/100	84/92	90/100	248/261	87/95	90/100	80/87	248/261	87/95	90/100	80/87	248/261	87/95	90/100	80/87	

See "Legend and Notes for Table 35 on page 37."

Table 35 – Unit Wire/Fuse or HACR Breaker Sizing Data (cont)

UNIT	NO M. V.-Ph-HZ	ELEC. HTR			NO C.O. or UNPWR C.O.						w/ PWRD C.O.											
		IFM TYPE	CRHEATER**A00	Nom (kW)	FLA	NO PE.			w/ PE. (pwrdr fr/unit)			NO PE.			w/ PE. (pwrdr fr/unit)							
						MCA	MAX FUSE or HACR BRKR	DISC. SIZE FLA LRA	MCA	MAX FUSE or HACR BRKR	DISC. SIZE FLA LRA	MCA	MAX FUSE or HACR BRKR	DISC. SIZE FLA LRA	MCA	MAX FUSE or HACR BRKR	DISC. SIZE FLA LRA					
50KCA05	DD - STD	NONE	-	-	-	13	47	14	20	14	48	15	20	15	49	16	20	16	20	16	50	
		106A	6.0	7.2	22	54	21	25	22	25	55	23	25	23	23	56	25	25	25	25	25	57
		108A	11.5	13.8	30	61	29	31	30	35	62	32	32	31	31	63	33	35	31	35	32	64
		109A	14.0	16.8	34	64	32	35	33	35	65	36	36	40	40	66	37	40	35	40	36	67
		108A+108A	23.0	27.7	48	102	45	50	46	50	103	50	50	50	50	104	51	60	47	60	48	105
	MED	NONE	-	-	12	61	11	15	12	15	62	14	15	15	13	63	15	20	13	20	15	64
		106A	6.0	7.2	21	68	19	25	20	25	69	23	25	25	22	70	24	25	22	25	23	71
		108A	11.5	13.8	29	75	27	30	28	30	76	31	31	35	29	77	32	35	29	35	30	78
		109A	14.0	16.8	33	78	30	35	31	35	79	34	35	35	33	80	36	40	33	40	34	81
		108A+108A	23.0	27.7	46	116	43	50	44	50	117	48	50	50	45	118	49	50	45	50	46	119
HIGH	NONE	-	-	13	79	13	15	14	20	80	15	15	20	15	81	16	20	15	20	17	82	
	106A	6.0	7.2	22	86	21	25	22	25	87	24	25	25	24	88	25	25	24	25	25	89	
	108A	11.5	13.8	30	93	29	30	30	35	94	31	35	35	31	95	34	35	31	35	32	96	
	109A	14.0	16.8	34	96	32	35	33	35	97	36	40	40	35	98	37	40	35	40	36	99	
	108A+108A	23.0	27.7	48	134	45	50	46	50	135	50	50	50	47	136	51	60	47	60	48	137	
DD - STD			11	39	11	15	13	15	41	13	15	15	13	41	15	20	13	20	15	43		
MED			9	42	8	15	10	15	44	11	15	15	10	44	12	15	10	15	12	46		
HIGH			10	57	10	15	12	15	59	12	15	15	12	59	14	15	12	15	14	61		

See "Legend and Notes for Table 35 on page 37.

Table 35 – Unit Wire/Fuse or HACR Breaker Sizing Data (cont)

UNIT	NO M. V-Ph-HZ	ELEC. HTR			NO C.O. or UNPWR C.O.						w/ PWRD C.O.											
		IFM TYPE	CRHEATER**A00	Nom (kW)	FLA	NO PE.			w/ PE. (pwrd fr/unit)			NO PE.			w/ PWRD C.O.							
						MCA	MAX FUSE or HACR BRKR	DISC. SIZE FLA LRA	MCA	MAX FUSE or HACR BRKR	DISC. SIZE FLA LRA	MCA	MAX FUSE or HACR BRKR	DISC. SIZE FLA LRA	MCA	MAX FUSE or HACR BRKR	DISC. SIZE FLA LRA					
50KCA06	460-3-60	DD-STD	NONE	-	-	14	20	14	58	15	20	15	59	16	20	16	60	17	20	17	61	
			106A	6.0	7.2	23	25	22	65	23	24	25	23	66	24	25	24	67	26	30	26	68
			108A	11.5	13.8	31	35	29	72	31	32	35	31	73	32	35	32	74	34	35	33	75
			109A	14.0	16.8	35	35	33	75	34	36	40	34	76	35	40	35	77	38	40	37	78
			108A+108A	23.0	27.7	49	50	45	113	47	50	50	47	114	48	60	48	115	52	60	49	116
			108A+109A	25.5	30.7	52	60	49	119	50	53	60	50	120	51	60	51	121	56	60	53	122
			NONE	-	-	14	20	14	90	15	15	20	15	91	16	20	16	92	17	20	17	93
			106A	6.0	7.2	23	25	22	97	23	24	25	23	98	25	30	25	99	26	30	26	100
			108A	11.5	13.8	31	35	30	104	31	32	35	31	105	32	35	32	106	35	35	33	107
			109A	14.0	16.8	35	35	33	107	34	36	40	34	108	36	40	36	109	38	40	37	110
HIGH	460-3-60	108A+108A	23.0	27.7	49	50	46	145	47	50	47	146	48	60	48	147	52	60	49	148		
		108A+109A	25.5	30.7	53	60	49	151	54	60	50	152	55	60	52	153	56	60	53	154		
		NONE	-	-	14	20	14	90	15	15	20	15	91	16	20	16	92	17	20	17	93	
		106A	6.0	7.2	23	25	22	97	23	24	25	23	98	25	30	25	99	26	30	26	100	
DD-STD	575-3-60	NONE	-	-	12	15	11	46	14	15	14	48	13	15	13	48	15	20	16	50		
		NONE	-	-	10	15	10	64	12	15	12	66	12	15	12	66	14	15	14	68		
		NONE	-	-	10	15	10	64	12	15	12	66	12	15	12	66	14	15	14	68		

See "Legend and Notes for Table 35 on page 37.



SEQUENCE OF OPERATION

Cooling, unit without economizer

Cooling (Single speed indoor fan motor) —

When thermostat calls for cooling, terminals G and Y1 are energized. The indoor fan contactor (IFC), reversing valve solenoid (RVS) and compressor contactor are energized and indoor fan motor, compressor, and outdoor fan starts. The outdoor fan motor runs continuously while unit is cooling.

Two-stage models: If Stage 1 cooling does not satisfy the space load, the space temperature will rise until thermostat calls for Stage 2 cooling (Y2 closes). Defrost Board activates Stage 2 Compressor. Reversing valve 2 switches to Cooling position. Compressor 2 contactor is energized; Compressor 2 starts and Circuit 2 operates in Cooling mode.

When Cooling Stage 2 is satisfied, thermostat Y2 opens. Compressor 2 contactor is de-energized; Compressor 2 stops. Reversing Valve 2 remains energized.

When Cooling Stage 1 is satisfied, thermostat Y1 opens. Compressor 1 contactor is de-energized; Compressor 1 stops. Outdoor fan relay is de-energized; outdoor fans stop. After the Fan Delay period, the Indoor fan contactor is de-energized; indoor fan stops (unless Continuous Fan operation has been selected). Reversing Valve 1 remains energized.

Reversing valve solenoids are energized in Cooling modes. Each solenoid will remain energized until the next Heating mode is initiated for this circuit.

Heating, unit without economizer

Upon a request for heating from the space thermostat, terminal W1 will be energized with 24V. The IFC, outdoor fan contactor (OFC), C1, and C2 will be energized. The indoor fan, outdoor fans, and compressor no. 1, and compressor no. 2 are energized and reversing valves are de-energized and switch position.

If the space temperature continues to fall while W1 is energized, W2 will be energized with 24V, and the heater contactor(s) (HC) will be energized, which will energize the electric heater(s).

When the space thermostat is satisfied, W2 will be de-energized first, and the electric heater(s) will be de-energized.

Upon a further rise in space temperature, W1 will be de-energized.

Two compressor models: When the thermostat calls for heating, terminal W1 is energized. Defrost Board de-energizes both reversing valve solenoids and reversing valves move to Heating position. The indoor fan contactor is energized; indoor fan motor starts. Outdoor fan relay is energized; both outdoor fan motors run. Compressor contactors C1 and C2 are energized; both refrigeration circuits operate in Heating mode.

If Stage 1 heating does not satisfy the space load, the space temperature will fall until thermostat calls for Stage 2 heating (W2 closes). Terminal W2 is energized. Defrost Board issues an output at EHEAT. Heater contactor 1 and heater contactor 2 (if installed) are energized; all electric heaters are energized.

When space heating load is partially satisfied, thermostat terminal W2 is de-energized; heater contactors are de-energized and all electric heat is terminated. Stage 1 heating continues.

When the space heating load is fully satisfied, thermostat terminal W1 is also de-energized.

Reversing valve solenoids remain de-energized until the next call for Cooling mode is initiated.

Cooling, unit with EconoMi\$er IV

When free cooling is not available, the compressors will be controlled by the zone thermostat. When free cooling is available, the outdoor air damper is modulated by the EconoMi\$er IV control to provide a 50 to 55°F (10° to 13°C) mixed air temperature into the zone. As the mixed air temperature fluctuates above 55 or below 50°F (13° to 10°C), the dampers will be modulated (open or close) to bring the mixed air temperature back within control.

If mechanical cooling is utilized with free cooling, the outdoor air damper will maintain its current position at the time the compressor is started. If the increase in cooling capacity causes the mixed air temperature to drop below 45°F (7°C), then the outdoor air damper position will be decreased to the minimum position. If the mixed air temperature continues to fall, the outdoor air damper will close. Control returns to normal once the mixed air temperature rises above 48°F (9°C).

If optional power exhaust is installed, as the outdoor air damper opens and closes, the power exhaust fans will be energized and de-energized.

If field-installed accessory CO₂ sensors are connected to the EconoMi\$er IV control, a demand controlled ventilation strategy will begin to operate. As the CO₂ level in the zone increases above the CO₂ setpoint, the minimum position of the damper will be increased proportionally. As the CO₂ level decreases because of the increase in fresh air, the outdoor air damper will be proportionally closed.

For EconoMi\$er IV operation, there must be a thermostat call for the fan (G). If the unit is occupied and the fan is on, the damper will operate at minimum position. Otherwise, the damper will be closed.

When the EconoMi\$er IV control is in the occupied mode and a call for cooling exists (Y1 on the thermostat), the control will first check for indoor fan operation. If the fan is not on, then cooling will not be activated. If the fan is on, then the control will open the EconoMi\$er IV damper to the minimum position.

SEQUENCE OF OPERATION (cont.)

On the initial power to the EconoMi\$er IV control, it will take the damper up to 2¹/₂ minutes before it begins to position itself. Any change in damper position will take up to 30 seconds to initiate. Damper movement from full closed to full open (or vice versa) will take between 1¹/₂ and 2¹/₂ minutes.

If free cooling can be used as determined from the appropriate changeover command (switch, dry bulb, enthalpy curve, differential dry bulb, or differential enthalpy), then the control will modulate the dampers open to maintain the mixed air temperature setpoint at 50° to 55°F (10° to 13°C).

If there is a further demand for cooling (cooling second stage — Y2 is energized), then the control will bring on compressor stage 1 to maintain the mixed air temperature setpoint. The EconoMi\$er IV damper will be open at maximum position. EconoMi\$er IV operation is limited to a single compressor.

Heating, unit with EconoMi\$er

When the room temperature calls for heat through terminal W1, the indoor (evaporator) fan contactor (IFC) and heater contactor no. 1 (HC1) are energized and the reversing valve(s) de-energize and switches position. On units equipped for 2 stages of heat, when additional heat is needed, heater contactor no. 2 is energized through W2. The economizer damper moves to the minimum position. When the thermostat is satisfied, the damper moves to the fully closed position.

Cooling, unit with EconoMi\$er2, PremierLink control and a thermostat

When free cooling is not available, the compressors will be controlled by the PremierLink control in response to the Y1 and Y2 inputs from the thermostat.

The PremierLink control will use the following information to determine if free cooling is available:

- Indoor fan has been on for at least 30 seconds.
- The SPT, SAT, and OAT inputs must have valid readings.
- OAT must be less than 75°F (24°C).
- OAT must be less than SPT.
- Enthalpy must be LOW (may be jumpered if an enthalpy sensor not available).
- Economizer position is NOT forced.

Pre-cooling occurs when there is no call from the thermostat except G. Pre-cooling is defined as the economizer modulates to provide 70°F (21°C) supply air.

When free cooling is available the PremierLink control will control the compressors, energize the reversing valve(s) and economizer to provide a supply air temperature determined to meet the Y1 and Y2 calls from the thermostat.

If optional power exhaust is installed, as the outdoor air damper opens and closes, the power exhaust fans will be energized and de-energized.

If field-installed accessory CO₂ sensors are connected to the PremierLink control, a PID controlled demand ventilation strategy will begin to operate. As the CO₂ level in the zone increases above the CO₂ setpoint, the minimum position of the damper will be increased proportionally. As the CO₂ level decreases because of the increase in fresh air, the outdoor air damper will be proportionally closed.

Heating, unit with EconoMi\$er2, PremierLink control and a thermostat

When the thermostat calls for heating, terminal W1 is energized. The PremierLink control will move the economizer damper to the minimum position if there is a call for G and closed if there is a call for W1 without G. In order to prevent thermostat from short cycling, the unit is locked into the heating mode for at least 10 minutes when W1 is energized. The reversing valve solenoid(s) de-energizes and switches position.

On units equipped for two stages of heat, when additional heat is needed, W2 is energized and the electric heat (if used) comes on. When the thermostat is satisfied and W1 is de-energized, the IFM stops.

Cooling, unit with EconoMi\$er2, PremierLink control and a room sensor

When free cooling is not available, the compressors will be controlled by the PremierLink controller using a PID Error reduction calculation.

The PremierLink controller will use the following information to determine if free cooling is available:

- Indoor fan has been on for at least 30 seconds.
- The SPT, SAT, and OAT inputs must have valid readings.
- OAT must be less than 75°F (24°C).
- OAT must be less than SPT.
- Enthalpy must be LOW (may be jumpered if an enthalpy sensor is not available).
- Economizer position is NOT forced.

When free cooling is available, the outdoor air damper is positioned through the use of a Proportional Integral (PID) control process to provide a calculated supply air temperature into the zone. The supply air will maintain the space temperature between the heating and cooling setpoints.

The PremierLink control will integrate the compressors stages with the economizer based on similar logic as the three routines listed in the previous section. The SASP will float up and down based on the error reduction calculations that compare space temperature and space setpoint. The reversing valves will be energized.

SEQUENCE OF OPERATION (cont.)

If an optional power exhaust is installed, as the outdoor air damper opens and closes, the power exhaust fans will be energized and de-energized.

If field- installed accessory CO₂ sensors are connected to the PremierLink control, a PID-controlled demand ventilation strategy will begin to operate. As the CO₂ level in the zone increases above the CO₂ setpoint, the minimum position of the damper will be increased proportionally. As the CO₂ level decreases because of the increase in fresh air, the outdoor air damper will be proportionally closed.

Heating, unit with EconoMiser2, PremierLink control and a room sensor

Every 40 seconds the controller will calculate the required heat stages (maximum of 3) to maintain Supply Air Temperature (SAT) if the following qualifying conditions are met:

- Indoor fan has been on for at least 30 seconds.
- COOL mode is not active.
- OCCUPIED, TEMP.COMPENSATED START or HEAT mode is active.
- SAT reading is available.
- Fire shutdown mode is not active.

If all of the above conditions are met, the number of heat stages is calculated; otherwise the required number of heat stages will be set to 0.

If the PremierLink controller determines that heat stages are required, the economizer damper will be moved to minimum position if occupied and closed if unoccupied.

Defrost

When the temperature of the outdoor coil drops below 28°F (-2°C) as sensed by the defrost thermostat (DFT2) and the defrost timer is at the end of a timed period (adjustable at 30, 60, 90 or 120 minutes), reversing valve solenoids (RVS1 and RVS2) are energized and the OFC is de-energized. This switches the position of the reversing valves and shuts off the outdoor fan. The electric heaters (if installed) will be energized.

The unit continues to defrost until the coil temperature as measured by DFT2 reaches 65°F (18°C), or the duration of defrost cycle completes a 10-minute period.

During the Defrost mode, if circuit 1 defrosts first, RVS1 will oscillate between Heating and Cooling modes until the Defrost mode is complete.

At the end of the defrost cycle, the electric heaters (if installed) will be de-energized; the reversing valves switch and the outdoor fan motor will be energized. The unit will now operate in the Heating mode.

If the space thermostat is satisfied during a defrost cycle, the unit will continue in the Defrost mode until the time or temperature constraints are satisfied.

Automatic changeover

When the system selection switch is set at AUTO position, unit automatically changes from heating operation to cooling operation when the temperature of the conditioned space rises to the cooling level setting. When the temperature of the conditioned space falls to the heating level setting, unit automatically changes from cooling to heating operation (with a 3°F deadband in between).

Continuous air circulation

Turn unit power on. Set system control at OFF position. Set fan switch at ON position. The indoor fan contactor is energized through the thermostat switch and the indoor fan runs continuously.

Emergency heat

When the switch is on (thermostat is set to the EM HT position), compressor circuit and outdoor thermostats are bypassed, and the second stage of thermostat energizes the indoor blower and the electric resistance heaters.

GUIDE SPECIFICATIONS - 50KCQ*04-06

Note about this specification:

Carrier created this specification in "Masterformat" as published by the Construction Specification Institute. Please feel free to copy this specification directly into your building specifications.

Rooftop Packaged Heat Pump

HVAC Guide Specifications

Size Range: 3 to 5 Nominal Tons



<u>Section</u>	<u>Description</u>
----------------	--------------------

23 06 80	Schedules for Decentralized HVAC Equipment
-----------------	---

23 06 80.13	Decentralized Unitary HVAC Equipment Schedule
-------------	---

23 06 80.13.A.	Rooftop unit schedule
----------------	-----------------------

1. Schedule is per the project specification requirements.

23 07 16	HVAC Equipment Insulation
-----------------	----------------------------------

23 07 16.13	Decentralized, Rooftop Units:
-------------	-------------------------------

23 07 16.13.A.	Evaporator fan compartment:
----------------	-----------------------------

1. Interior cabinet surfaces shall be insulated with a minimum 1/2-in. thick, minimum 1 1/2 lb density, flexible fiberglass insulation bonded with a phenolic binder, neoprene coated on the air side.
2. Insulation and adhesive shall meet NFPA 90A requirements for flame spread and smoke generation.

23 07 16.13.B.	Electric heat compartment:
----------------	----------------------------

1. Aluminum foil-faced fiberglass insulation shall be used.
2. Insulation and adhesive shall meet NFPA 90A requirements for flame spread and smoke generation.

23 09 13	Instrumentation and Control Devices for HVAC
-----------------	---

23 09 13.23	Sensors and Transmitters
-------------	--------------------------

23 09 13.23.A.	Thermostats
----------------	-------------

1. Thermostat must
 - a. have capability to energize 2 different stages of cooling, and 2 different stages of heating.
 - b. include capability for occupancy scheduling.

23 09 23	Direct-digital Control system for HVAC
-----------------	---

23 09 23.13	Decentralized, Rooftop Units:
-------------	-------------------------------

23 09 23.13.A.	PremierLink™ controller
----------------	-------------------------

1. Shall be ASHRAE compliant.
2. Shall accept 18-32VAC input power.
3. Shall have an operating temperature range from -40°F (-40°C) to 158°F (70°C), 10% - 95% RH (non-condensing).
4. Shall include an integrated economizer controller to support an economizer with 4 to 20 mA actuator input and no microprocessor controller.
5. Controller shall accept the following inputs: space temperature, setpoint adjustment, outdoor air temperature, indoor air quality, outdoor air quality, indoor relative humidity, compressor lock-out, fire shutdown, enthalpy, fan status, remote time clock/door switch.
6. Shall accept a CO₂ sensor in the conditioned space, and be Demand Control Ventilation (DCV) ready.
7. Shall provide the following outputs: Economizer, fan, cooling stage 1, cooling stage 2, heat stage 1, heat stage 2, heat stage 3/ exhaust/ reversing valve/ dehumidify/ occupied.
8. Unit shall provide surge protection for the controller through a circuit breaker.
9. Shall be Internet capable, and communicate at a Baud rate of 38.4K or faster
10. Shall have an LED display independently showing the status of activity on the communication bus, and processor operation.
11. Shall include an EIA-485 protocol communication port, an access port for connection of either a computer or a Carrier technician tool, an EIA-485 port for network communication to intelligent space sensors and displays, and a port to connect an optional LonWorks plug-in communications card.

50KCQ

12. Shall have built-in Carrier Comfort Network (CCN) protocol, and be compatible with other CCN devices, including ComfortLink and ComfortVIEW controllers.
13. Shall have built-in support for Carrier technician tool.
14. Software upgrades will be accomplished by local download. Software upgrades through chip replacements are not allowed.
15. Shall be shock resistant in all planes to 5G peak, 11ms during operation, and 100G peak, 11ms during storage.
16. Shall be vibration resistant in all planes to 1.5G @ 20-300 Hz.
17. Shall support a bus length of 4000 ft max, 60 devices per 1000 ft section, and 1 RS-485 repeater per 1000ft sections.

23 09 23.13.B. RTU Open Multi-protocol, direct digital controller:

1. Shall be ASHRAE 62 compliant.
2. Shall accept 18-30VAC, 50-60Hz, and consumer 15VA or less power.
3. Shall have an operating temperature range from -40°F (-40°C) to 130°F (54°C), 10% - 90% RH (non-condensing).
4. Shall include built-in protocol for BACNET (MS/TP and PTP modes), Modbus (RTU and ASCII), Johnson N2 and LonWorks. LonWorks Echelon processor required for all Lon applications shall be contained in separate communication board.
5. Shall allow access of up to 62 network variables (SNVT). Shall be compatible with all open controllers
6. Baud rate Controller shall be selectable using a dipswitch.
7. Shall have an LED display independently showing the status of serial communication, running, errors, power, all digital outputs, and all analog inputs.
8. Shall accept the following inputs: space temperature, setpoint adjustment, outdoor air temperature, indoor air quality, outdoor air quality, compressor lock-out, fire shutdown, enthalpy switch, and fan status/filter status/humidity/remote occupancy.
9. Shall provide the following outputs: economizer, fan, cooling stage 1, cooling stage 2, heat stage 1, heat stage 2, heat stage 3/ exhaust/ reversing valve.
10. Shall have built-in surge protection circuitry through solid state polyswitches. Polyswitches shall be used on incoming power and network connections. Polyswitches will return to normal when the "trip" condition clears.
11. Shall have a battery back-up capable of a minimum of 10,000 hours of data and time clock retention during power outages.
12. Shall have built-in support for Carrier technician tool.
13. Shall include an EIA-485 protocol communication port, an access port for connection of either a computer or a Carrier technician tool, an EIA-485 port for network communication to intelligent space sensors and displays, and a port to connect an optional LonWorks communications card.
14. Software upgrades will be accomplished by either local or remote download. No software upgrades through chip replacements are allowed.

23 09 33 Electric and Electronic Control System for HVAC

23 09 33.13 Decentralized, Rooftop Units:

23 09 33.13.A. General:

1. Shall be complete with self-contained low voltage control circuit protected by a resettable circuit breaker on the 24-v transformer side. Transformer shall have 75VA capability.
2. Shall utilize color-coded wiring.
3. Shall include a central control terminal board to conveniently and safely provide connection points for vital control functions such as: smoke detectors, phase monitor, economizer, thermostat, DDC control options, loss of charge, freeze switch, high pressure switches.
4. Unit shall include a minimum of one 8-pin screw terminal connection board for connection of control wiring.
5. Shall include integrated defrost system to prevent excessive frost accumulation during heating duty, and shall be controlled as follows:
 - a. Defrost shall be initiated on the basis of time and coil temperature.
 - b. A 30,60,90,120 minute timer shall activate the defrost cycle only if the coil temperature is low enough to indicate a heavy frost condition.
 - c. Defrost cycle shall terminate when defrost thermostat is satisfied and shall have a positive termination time of 10 minutes.
6. Defrost system shall also include:
 - a. Defrost Cycle Indicator LED.
 - b. Dip switch selectable defrost time between 30,60,90 and 120 minutes. Factory set at 30 minutes.
 - c. Molded plug connection to insure proper connection.

23 09 33.23.B. Safeties:

1. Compressor overtemperature, overcurrent.
2. Loss of charge switch.
 - a. Loss of charge switch shall use different color wire than the high pressure switch. The purpose is to assist the installer and service technician to correctly wire and or troubleshoot the rooftop unit.
3. High pressure switch.
 - a. High pressure switch shall use different color wire than the low pressure switch. The purpose is to assist the installer and service technician to correctly wire and or troubleshoot the rooftop unit.
4. Freeze protection thermostat, evaporator coil.
5. Automatic reset, motor thermal overload protector.

23 09 93 Sequence of Operations for HVAC Controls

23 09 93.13 Decentralized, Rooftop Units:

23 09 93.13 INSERT SEQUENCE OF OPERATION

23 40 13 Panel Air Filters

23 40 13.13 Decentralized, Rooftop Units:

23 40 13.13.A. Standard filter section

1. Shall consist of factory-installed, low velocity, throwaway 2-in. thick fiberglass filters of commercially available sizes.
2. Unit shall use only one filter size. Multiple sizes are not acceptable.
3. Filters shall be accessible through an access panel with “no-tool” removal as described in the unit cabinet section of this specification (23 81 19.13.G).

23 81 19 Self-Contained Air Conditioners

23 81 19.13 Small-Capacity Self-Contained Air Conditioners (50KCQ*04-06)

23 81 19.13.A. General

1. Outdoor, rooftop mounted, electrically controlled, heating and cooling unit utilizing a(n) hermetic scroll compressor(s) for cooling duty and heat pump for heating duty.
2. Factory assembled, single piece heating and cooling rooftop unit. Contained within the unit enclosure shall be all factory wiring, piping, controls, and special features required prior to field startup.
3. Unit shall use Puron refrigerant.
4. Unit shall be installed in accordance with the manufacturer’s instructions.
5. Unit must be selected and installed in compliance with local, state, and federal codes.

23 81 19.13.B. Quality Assurance

1. Unit meets ASHRAE 90.1 minimum efficiency requirements.
2. Unit shall be rated in accordance with AHRI Standards 210/240.
3. Unit shall be designed to conform to ASHRAE 15.
4. Unit shall be UL-tested and certified in accordance with ANSI Z21.47 Standards and UL-listed and certified under Canadian standards as a total package for safety requirements.
5. Insulation and adhesive shall meet NFPA 90A requirements for flame spread and smoke generation.
6. Unit casing shall be capable of withstanding 500-hour salt spray exposure per ASTM B117 (scribed specimen).
7. Unit shall be designed in accordance with ISO 9001, and shall be manufactured in a facility registered by ISO 9001.
8. Roof curb shall be designed to conform to NRCA Standards.
9. Unit shall be subjected to a completely automated run test on the assembly line. The data for each unit will be stored at the factory, and must be available upon request.
10. Unit shall be designed in accordance with UL Standard 1995, including tested to withstand rain.
11. Unit shall be constructed to prevent intrusion of snow and tested to prevent snow intrusion into the control box up to 40 mph.
12. Unit shake tested to assurance level 1, ASTM D4169 to ensure shipping reliability.

23 81 19.13.C. Delivery, Storage, and Handling

1. Unit shall be stored and handled per manufacturer’s recommendations.
2. Lifted by crane requires either shipping top panel or spreader bars.
3. Unit shall only be stored or positioned in the upright position.

23 81 19.13.D. Project Conditions

1. As specified in the contract.

23 81 19.13.E. Operating Characteristics

1. Unit shall be capable of starting and running at 115°F (46°C) ambient outdoor temperature, meeting maximum load criteria of AHRI Standard 210/240 at ± 10% voltage.
2. Compressor with standard controls shall be capable of operation from 25°F (-4°C), ambient outdoor temperatures. Accessory winter start kit is necessary if mechanically cooling at ambient temperatures below 25°F (-4°C).
3. Unit shall be capable of simultaneous heating duty and defrost cycle operation when using accessory electric heaters.
4. Unit shall discharge supply air vertically or horizontally as shown on contract drawings.
5. Unit shall be factory configured for vertical supply & return configurations.
6. Unit shall be field convertible from vertical to horizontal configuration
7. Unit shall be capable of mixed operation: vertical supply with horizontal return or horizontal supply with vertical return.

23 81 19.13.F. Electrical Requirements

1. Main power supply voltage, phase, and frequency must match those required by the manufacturer.

23 81 19.13.G. Unit Cabinet

1. Unit cabinet shall be constructed of galvanized steel, and shall be bonderized and coated with a prepainted baked enamel finish on all externally exposed surfaces.
2. Unit cabinet exterior paint shall be: film thickness, (dry) 0.003 inches minimum, gloss (per ASTM D523, 60°F): 60, Hardness: H-2H Pencil hardness.
3. Evaporator fan compartment interior cabinet insulation shall conform to AHRI Standards 210/240 minimum exterior sweat criteria. Interior surfaces shall be insulated with a minimum 1/2-in. thick, 1 lb density, flexible fiberglass insulation, neoprene coated on the air side. Aluminum foil-faced fiberglass insulation shall be used in the heat compartment.
4. Base of unit shall have a minimum of three locations for thru-the-base electrical connections (factory-installed or field-installed), standard.
5. Base Rail
 - a. Unit shall have base rails on a minimum of 2 sides.
 - b. Holes shall be provided in the base rails for rigging shackles to facilitate maneuvering and overhead rigging.
 - c. Holes shall be provided in the base rail for moving the rooftop by fork truck.
 - d. Base rail shall be a minimum of 16 gauge thickness.
6. Condensate pan and connections:
 - a. Shall be a sloped condensate drain pan made of a non-corrosive material.
 - b. Shall comply with ASHRAE Standard 62.
 - c. Shall use a 3/4-in. -14 NPT drain connection, possible either through the bottom or end of the drain pan. Connection shall be made per manufacturer's recommendations.
7. Top panel:
 - a. Shall be a single piece top panel on all sizes.
8. Electrical Connections
 - a. All unit power wiring shall enter unit cabinet at a single, factory prepared, knockout location.
 - b. Thru-the-base capability.
 - (1.) Standard unit shall have a thru-the-base electrical location (s) using a raised, embossed portion of the unit basepan.
 - (2.) Optional, factory-approved, water-tight connection method must be used for thru-the-base electrical connections.
 - (3.) No basepan penetration, other than those authorized by the manufacturer, is permitted.
9. Component access panels (standard)
 - a. Cabinet panels shall be easily removable for servicing.
 - b. Unit shall have one factory-installed, tool-less, removable, filter access panel.
 - c. Panels covering control box, indoor fan, indoor fan motor, gas components (where applicable), and compressors shall have molded composite handles.
 - d. Handles shall be UV modified, composite. permanently attached, and recessed into the panel.
 - e. Screws on the vertical portion of all removable access panel shall engage into heat resistant, molded composite collars.
 - f. Collars shall be removable and easily replaceable using manufacturer recommended parts.

23 81 19.13.H. Coils

1. Standard Aluminum/Copper Coils: on all models.
 - a. Standard evaporator and condenser coils shall have aluminum lanced plate fins mechanically bonded to seamless internally grooved copper tubes with all joints brazed.
 - b. Evaporator coils shall be leak tested to 150 psig, pressure tested to 450 psig, and qualified to UL 1995 burst test at 1775 psig.
 - c. Condenser coils shall be leak tested to 150 psig, pressure tested to 650 psig, and qualified to UL 1995 burst test at 1980 psig.
2. Optional Pre-coated aluminum fin condenser coils: on all models.
 - a. Shall have a durable epoxy-phenolic coating to provide protection in mildly corrosive coastal environments.
 - b. Coating shall be applied to the aluminum fin stock prior to the fin stamping process to create an inert barrier between the aluminum fin and copper tube.
 - c. Epoxy-phenolic barrier shall minimize galvanic action between dissimilar metals.
3. Optional Copper-fin evaporator and condenser coils: on all models.
 - a. Shall be constructed of copper fins mechanically bonded to copper tubes and copper tube sheets.
 - b. Galvanized steel tube sheets shall not be acceptable.
 - c. A polymer strip shall prevent coil assembly from contacting the sheet metal coil pan to minimize potential for galvanic corrosion between coil and pan.
4. Optional E-coated aluminum-fin evaporator and condenser coils: (3 Phase Models Only):
 - a. Shall have a flexible epoxy polymer coating uniformly applied to all coil surface areas without material bridging between fins.
 - b. Coating process shall ensure complete coil encapsulation of tubes, fins and headers.
 - c. Color shall be high gloss black with gloss per ASTM D523-89.
 - d. Uniform dry film thickness from 0.8 to 1.2 mil on all surface areas including fin edges.
 - e. Superior hardness characteristics of 2H per ASTM D3363-92A and cross-hatch adhesion of 4B-5B per ASTM D3359-93.
 - f. Impact resistance shall be up to 160 in.-lb (ASTM D2794-93).
 - g. Humidity and water immersion resistance shall be up to minimum 1000 and 250 hours respectively (ASTM D2247-92 and ASTM D870-92).
 - h. Corrosion durability shall be confirmed through testing to be no less than 1000 hours salt spray per ASTM B117-90.

23 81 19.13.I. Refrigerant Components

1. Refrigerant circuit shall include the following control, safety, and maintenance features:
 - a. Fixed orifice metering system shall prevent mal-distribution of two-phase refrigerant by including multiple fixed orifice devices in each refrigeration circuit. Each orifice is to be optimized to the coil circuit it serves.
 - b. Refrigerant filter drier.
 - c. Service gauge connections on suction and discharge lines.
 - d. Pressure gauge access through a specially designed access port in the top panel of the unit.
 - e. Suction line accumulator to provide protection in all operating modes from cooling, heating and reverse cycle switching.
2. There shall be gauge line access port in the top of the rooftop, covered by a black, removable plug.
 - a. The plug shall be easy to remove and replace.
 - b. When the plug is removed, the gauge access port shall enable maintenance personnel to route their pressure gauge lines.
 - c. This gauge access port shall facilitate correct and accurate condenser pressure readings by enabling the reading with the compressor access panel on.
 - d. The plug shall be made of a leak proof, UV-resistant, composite material.
3. Compressors
 - a. Unit shall use one fully hermetic, scroll compressor for each independent refrigeration circuit.
 - b. Models shall be available with single compressor designs.
 - c. Compressor motors shall be cooled by refrigerant gas passing through motor windings.
 - d. Compressors shall be internally protected from high discharge temperature conditions.
 - e. Compressors shall be protected from an overtemperature and over-amperage conditions by an internal, motor overload device.
 - f. Compressor shall be factory mounted on rubber grommets.

- g. Compressor motors shall have internal line break thermal, current overload and high pressure differential protection.
- h. Crankcase heaters shall not be required for normal operating range, unless provided by compressor manufacturer due to refrigerant charge limits.

23 81 19.13.J. Filter Section

1. Filters access is specified in the unit cabinet section of this specification.
2. Filters shall be held in place by a pivoting filter tray, facilitating easy removal and installation.
3. Shall consist of factory-installed, low velocity, throw-away 2-in. thick fiberglass filters.
4. Filters shall be standard, commercially available sizes.
5. Only one size filter per unit is allowed.

23 81 19.13.K. Evaporator Fan and Motor

1. Evaporator fan motor:
 - a. Shall have permanently lubricated bearings.
 - b. Shall have inherent automatic-reset thermal overload protection or circuit breaker.
 - c. Shall have a maximum continuous bhp rating for continuous duty operation; no safety factors above that rating shall be required.
2. Direct Drive - ECM Evaporator Fan Standard:
 - a. Multi speed motor with easy quick adjustment settings.
 - b. Blower fan shall be double inlet type with forward curved blades.
 - c. Shall be constructed from steel with a corrosion resistant finish and dynamically balanced.
 - d. Standard on all 04-06 models.
3. Belt-driven Evaporator Fan Optional:
 - a. Belt drive shall include an adjustable pitch motor pulley.
 - b. Shall use sealed, permanently lubricated ball-bearing type.
 - c. Blower fan shall be double inlet type with forward curved blades.
 - d. Shall be constructed from steel with a corrosion resistant finish and dynamically balanced.

23 81 19.13.L. Condenser Fans and Motors

1. Condenser fan motors:
 - a. Shall be a totally enclosed motor.
 - b. Shall use permanently lubricated bearings.
 - c. Shall have inherent thermal overload protection with an automatic reset feature.
 - d. Shall use a shaft down design on all sizes.
2. Condenser Fans:
 - a. Shall be a direct driven propeller type fan.
 - b. Shall have galvalum blades riveted to corrosion resistant steel spiders and shall be dynamically balanced.

23 81 19.13.M. Special Features, Options and Accessories

1. Integrated EconoMi\$er IV, EconoMi\$er2, and EconoMi\$er X standard leak rate models. (Factory installed on 3 phase models only. Field installed on all 3 and 1 phase models)
 - a. Integrated, gear driven opposing modulating blade design type capable of simultaneous economizer and compressor operation.
 - b. Independent modules for vertical or horizontal return configuration shall be available. Vertical return modules shall be available as a factory installed option.
 - c. Damper blades shall be galvanized steel with composite gears. Plastic or composite blades on intake or return shall not be acceptable.
 - d. Shall include all hardware and controls to provide free cooling with outdoor air when temperature and/or humidity are below setpoints.
 - e. Shall be equipped with gear driven dampers for both the outdoor ventilation air and the return air for positive air stream control.
 - f. Standard leak rate shall be equipped with dampers not to exceed 2% leakage at 1 in. wg pressure differential.
 - g. Economizer controller on EconoMi\$er IV models shall be Honeywell W7212 that provides:
 - (1.) Combined minimum and DCV maximum damper position potentiometers with compressor staging relay.
 - (2.) Functions with solid state analog enthalpy or dry bulb changeover control sensing.
 - (3.) Contain LED indicates for:
 - when free cooling is available, when module is in DCV mode, when exhaust fan contact is closed.

- h. Economizer controller on EconoMi\$er X models shall be the Honeywell W7220 that provides:
 - (1.) 2-line LCD interface screen for setup, configuration and troubleshooting.
 - (2.) On-board Fault Detection and Diagnostics (FDD) that senses and alerts when the economizer is not operating properly, per California Title 24.
 - (3.) Sensor failure loss of communication identification
 - (4.) Automatic sensor detection
 - (5.) Capabilities for use with multiple-speed indoor fan systems
 - (6.) Utilize digital sensors: Dry bulb and Enthalpy
 - i. Economizer controller on EconoMi\$er 2 models with PremierLink shall be 4-20mA design and controlled by the PremierLink controller. PremierLink does not comply with California Title 24 Fault Detection & Diagnostic (FDD) requirements.
 - j. Economizer controller on EconoMi\$er 2 models with RTU Open models shall be a 4-20mA design controlled directly by the RTU Open controller. RTU Open meets California Title 24 Fault Detection & Diagnostic (FDD) requirements.
 - k. Shall be capable of introducing up to 100% outdoor air.
 - l. Shall be equipped with a barometric relief damper capable of relieving up to 100% return air and contain seals that meet ASHRAE 90.1 requirements.
 - m. Shall be designed to close damper(s) during loss-of-power situations with spring return built into motor.
 - n. Dry bulb outdoor air temperature sensor shall be provided as standard. Enthalpy sensor is also available on factory installed only. Outdoor air sensor setpoint shall be adjustable and shall range from 40 to 100°F / 4 to 38°C. Additional sensor options shall be available as accessories.
 - o. The economizer controller shall also provide control of an accessory power exhaust unit function. Factory set at 100%, with a range of 0% to 100%.
 - p. The economizer shall maintain minimum airflow into the building during occupied period and provide design ventilation rate for full occupancy.
 - q. Dampers shall be completely closed when the unit is in the unoccupied mode.
 - r. Economizer controller shall accept a 2-10 Vdc CO₂ sensor input for IAQ/DCV control. In this mode, dampers shall modulate the outdoor air damper to provide ventilation based on the sensor input.
 - s. Compressor lockout temperature on W7220 is adjustable from -45°F to 80°F, set at a factory default of 32°F. Others shall open at 35°F (2°C) and closes at 50°F (10°C).
 - t. Actuator shall be direct coupled to economizer gear. No linkage arms or control rods shall be acceptable.
 - u. Economizer controller shall provide indications when in free cooling mode, in the DCV mode, or the exhaust fan contact is closed.
2. Integrated EconoMi\$er2, and EconoMi\$er X Ultra Low Leak rate models.(Factory installed on 3 phase models only. Field installed on all 3 and 1 phase models)
- a. Integrated, gear driven opposing modulating blade design type capable of simultaneous economizer and compressor operation.
 - b. Independent modules for vertical or horizontal return configuration shall be available. Vertical return modules shall be available as a factory installed option.
 - c. Damper blades shall be galvanized steel with composite gears. Plastic or composite blades on intake or return shall not be acceptable.
 - d. Shall include all hardware and controls to provide free cooling with outdoor air when temperature and/or humidity are below setpoints.
 - e. Shall be equipped with gear driven dampers for both the outdoor ventilation air and the return air for positive air stream control
 - f. Ultra Low Leak design meets California Title 24 section 140.4 and ASHRAE90.1 requirements for 4 cfm per sq.ft. on the outside air dampers and 10 cfm per sq. ft. on the return dampers.
 - g. Economizer controller on EconoMi\$er X models shall be the Honeywell W7220 that provides:
 - (1.) 2-line LCD interface screen for setup, configuration and troubleshooting
 - (2.) On-board Fault Detection and Diagnostics (FDD) that senses and alerts when the economizer is not operating properly, per California Title 24.
 - (3.) Sensor failure loss of communication identification
 - (4.) Automatic sensor detection
 - (5.) Capabilities for use with multiple-speed indoor fan systems
 - (6.) Utilize digital sensors: Dry bulb and Enthalpy

- h. Economizer controller on EconoMiSer 2 models with RTU Open models shall be a 4-20mA design controlled directly by the RTU Open controller. RTU Open meets California Title 24 Fault Detection & Diagnostic (FDD) requirements.
 - i. Shall be capable of introducing up to 100% outdoor air.
 - j. Shall be equipped with a barometric relief damper capable of relieving up to 100% return air and contain seals that meet ASHRAE 90.1 requirements.
 - k. Shall be designed to close damper(s) during loss-of-power situations with spring return built into motor.
 - l. Dry bulb outdoor air temperature sensor shall be provided as standard. Enthalpy sensor is also available on factory installed only. Outdoor air sensor setpoint shall be adjustable and shall range from 40 to 100° F / 4 to 38° C. Additional sensor options shall be available as accessories.
 - m. The economizer controller shall also provide control of an accessory power exhaust unit function. Factory set at 100%, with a range of 0% to 100%.
 - n. The economizer shall maintain minimum airflow into the building during occupied period and provide design ventilation rate for full occupancy.
 - o. Dampers shall be completely closed when the unit is in the unoccupied mode.
 - p. Economizer controller shall accept a 2-10 Vdc CO₂ sensor input for IAQ/DCV control. In this mode, dampers shall modulate the outdoor air damper to provide ventilation based on the sensor input.
 - q. Compressor lockout temperature on W7220 is adjustable from -45° F to 80° F, set at a factory default of 32° F. Others shall open at 35°F (2°C) and closes at 50°F (10°C).
 - r. Actuator shall be direct coupled to economizer gear. No linkage arms or control rods shall be acceptable.
 - s. Economizer controller shall provide indications when in free cooling mode, in the DCV mode, or the exhaust fan contact is closed.
3. Two-Position Damper (Factory installed on 3 Phase Models Only. Field installed on all 3 and 1 Phase Models)
 - a. Damper shall be a Two-Position Damper. Damper travel shall be from the full closed position to the field adjustable %-open setpoint.
 - b. Damper shall include adjustable damper travel from 25% to 100% (full open).
 - c. Damper shall include single or dual blade, gear driven dampers and actuator motor.
 - d. Actuator shall be direct coupled to damper gear. No linkage arms or control rods shall be acceptable.
 - e. Damper will admit up to 100% outdoor air for applicable rooftop units.
 - f. Damper shall close upon indoor (evaporator) fan shutoff and/or loss of power.
 - g. The damper actuator shall plug into the rooftop unit's wiring harness plug. No hard wiring shall be required.
 - h. Outside air hood shall include aluminum water entrainment filter
 4. Head Pressure Control Package
 - a. Controller shall control coil head pressure by condenser fan speed modulation or condenser fan cycling and wind baffles.
 - b. Shall consist of solid state control and condenser coil temperature sensor to maintain condensing temperature between 90° F (32°C) and 110° F (43°C) at outdoor ambient temperatures down to -20° F (-29°C).
 5. Condenser Coil Hail Guard Assembly (Factory installed on 3 Phase Models Only. Field installed on all 3 and 1 Phase Models)
 - a. Shall protect against damage from hail.
 - b. Shall be louvered design.
 6. Unit Mounted, Non-Fused Disconnect Switch:
 - a. Switch shall be factory-installed, internally mounted.
 - b. National Electric Code (NEC) and UL approved non-fused switch shall provide unit power shutoff.
 - c. Shall be accessible from outside the unit
 - d. Shall provide local shutdown and lockout capability.
 7. Convenience Outlet:
 - a. Powered convenience outlet.
 - (1.) Outlet shall be powered from main line power to the rooftop unit.
 - (2.) Outlet shall be powered from line side or load side of disconnect by installing contractor, as required by code. If outlet is powered from load side of disconnect, unit electrical ratings shall be UL certified and rated for additional outlet amperage.
 - (3.) Outlet shall be factory-installed and internally mounted with easily accessible 115-v female receptacle.
 - (4.) Outlet shall include 15 amp GFI receptacles with independent fuse protection.

- (5.) Voltage required to operate convenience outlet shall be provided by a factory-installed step down transformer.
- (6.) Outlet shall be accessible from outside the unit.
- b. Non-Powered convenience outlet.
 - (1.) Outlet shall be powered from a separate 115-120v power source.
 - (2.) A transformer shall not be included.
 - (3.) Outlet shall be factory-installed and internally mounted with easily accessible 115-v female receptacle.
 - (4.) Outlet shall include 15 amp GFI receptacles.
 - (5.) Outlet shall be accessible from outside the unit.
8. Thru-the-Base Connectors:
 - a. Kits shall provide connectors to permit electrical connections to be brought to the unit through the unit basepan.
 - b. Minimum of three connection locations per unit.
9. Propeller Power Exhaust:
 - a. Power exhaust shall be used in conjunction with an integrated economizer.
 - b. Independent modules for vertical or horizontal return configurations shall be available.
 - c. Horizontal power exhaust shall be mounted in return ductwork.
 - d. Power exhaust shall be controlled by economizer controller operation. Exhaust fans shall be energized when dampers open past the 0-100% adjustable setpoint on the economizer control.
10. Roof Curbs (Vertical):
 - a. Full perimeter roof curb with exhaust capability providing separate air streams for energy recovery from the exhaust air without supply air contamination.
 - b. Formed galvanized steel with wood nailer strip and shall be capable of supporting entire unit weight.
 - c. Permits installation and securing of ductwork to curb prior to mounting unit on the curb.
11. High Static Indoor Fan Motor(s) and Drive(s) (04-06):
 - a. High static motor(s) and drive(s) shall be factory-installed to provide additional performance range.
12. Thru-the-Bottom Utility Connectors:
 - a. Kit shall provide connectors to permit gas and electrical connections to be brought to the unit through the basepan.
13. Outdoor Air Enthalpy Sensor:
 - a. The outdoor air enthalpy sensor shall be used to provide single enthalpy control. When used in conjunction with a return air enthalpy sensor, the unit will provide differential enthalpy control. The sensor allows the unit to determine if outside air is suitable for free cooling.
14. Return Air Enthalpy Sensor:
 - a. The return air enthalpy sensor shall be used in conjunction with an outdoor air enthalpy sensor to provide differential enthalpy control.
15. Indoor Air Quality (CO₂) Sensor:
 - a. Shall be able to provide demand ventilation indoor air quality (IAQ) control.
 - b. The IAQ sensor shall be available in duct mount, wall mount, or wall mount with LED display. The setpoint shall have adjustment capability.
16. Smoke detectors (Factory-Installed Only):
 - a. Shall be a Four-Wire Controller and Detector.
 - b. Shall be environmental compensated with differential sensing for reliable, stable, and drift-free sensitivity.
 - c. Shall use magnet activated test/reset sensor switches.
 - d. Shall have tool-less connection terminal access.
 - e. Shall have a recessed momentary switch for testing and resetting the detector.
 - f. Controller shall include:
 - (1.) One set of normally open alarm initiation contacts for connection to an initiating device circuit on a fire alarm control panel.
 - (2.) Two Form-C auxiliary alarm relays for interface with rooftop unit or other equipment.
 - (3.) One Form-C supervision (trouble) relay to control the operation of the Trouble LED on a remote test/reset station.
 - (4.) Capable of direct connection to two individual detector modules.
 - (5.) Can be wired to up to 14 other duct smoke detectors for multiple fan shutdown applications.
17. Time Guard

- a. Shall prevent compressor short cycling by providing a 5-minute delay (± 2 minutes) before restarting a compressor after shutdown for any reason.
 - b. One device shall be required per compressor.
18. Electric Heat:
- a. Heating Section
 - (1.) Heater element open coil resistance wire, nickel-chrome alloy, 0.29 inches inside diameter, strung through ceramic insulators mounted on metal frame. Coil ends are staked and welded to terminal screw slots.
 - (2.) Heater assemblies are provided with integral fusing for protection of internal heater circuits not exceeding 48 amps each. Auto reset thermo limit controls, magnetic heater contactors (24V coil) and terminal block all mounted in electric heater control box (minimum 18 ga galvanized steel) attached to end of heater assembly.
19. Hinged Access Panels
- a. Shall provide easy access through integrated quarter turn latches.
 - b. Shall be on major panels of: filters, control box, fan motor and compressor.

50KCQ

