

50TCQ*04—14
Single Package Heat Pump/Electric Heat
Nominal 3 to 12.5 Tons
With Puron (R-410A) Refrigerant



Service and Maintenance Instructions

TABLE OF CONTENTS

SAFETY CONSIDERATIONS	1
UNIT ARRANGEMENT AND ACCESS	3
RETURN AIR FILTERS:	3
SUPPLY FAN (BLOWER) SECTION	4
HEAT PUMP REFRIGERATION SYSTEM	9
PURON® (R-410A) REFRIGERANT	12
THERMOSTATIC EXPANSION VALVE (TXV)	13
COOLING CHARGING CHARTS	15
CONVENIENCE OUTLETS	23
HEAT PUMP CONTROLS	24
PROTECTIVE CONTROLS	24
COMMERCIAL DEFROST CONTROL	25
ELECTRIC HEATERS	28
SMOKE DETECTORS	31
PREMIERLINK™ CONTROL	38
RTU-OPEN CONTROL SYSTEM	39
SENSORY/ACCESSORY INSTALLATION	39
ADDITIONAL RTU-OPEN INSTALLATION AND TROUBLESHOOTING	39
PRE-START-UP	41
START-UP, PREMIERLINK™	43
START-UP, RTU-OPEN	43
FASTENER TORQUE VALUES	44
APPENDIX I. MODEL NUMBER SIGNIFICANCE ..	45
APPENDIX II. PHYSICAL DATA	47
APPENDIX III. FAN PERFORMANCE	49
APPENDIX IV. WIRING DIAGRAMS	62
APPENDIX V. MOTORMASTER SENSOR LOCATIONS	79
START-UP CHECKLIST	83

SAFETY CONSIDERATIONS

Installation and servicing of air-conditioning equipment can be hazardous due to system pressure and electrical components. Only trained and qualified service personnel should install, repair, or service air-conditioning equipment. Untrained personnel can perform only the basic maintenance functions such as replacing filters. Trained service personnel should perform all other service and maintenance operations.

When working on air-conditioning equipment, observe precautions in the literature, tags and labels attached to the unit, and other safety precautions that can apply. Follow all safety codes. Wear approved safety glasses and leather work gloves. Use quenching cloth for unbrazing operations. Have fire extinguishers available for all brazing operations.

Read these instructions thoroughly and follow all warnings or cautions attached to the unit. Consult local building codes and National Electrical Code (NEC) for special requirements.

Recognize safety information. This is the safety ALERT symbol . When you see this symbol on the unit and in instructions or manuals, be aware of the potential for physical injury hazards.

Understand the signal words **DANGER**, **WARNING**, and **CAUTION**. These words are used with the safety-ALERT symbol. **DANGER** indicates a hazardous situation which, if not avoided, **will** result in death or severe personal injury. **WARNING** indicates a hazardous situation which, if not avoided, **could** result in death or personal injury. **CAUTION** indicates a hazardous situation which, if not avoided, **could** result in minor to moderate injury or product and property damage. **NOTICE** is used to address practices not related to physical injury. **NOTE** is used to highlight suggestions which **will** result in enhanced installation, reliability, or operation.

⚠ WARNING

ELECTRICAL OPERATION HAZARD

Failure to follow this warning could result in personal injury or death.

Before performing service or maintenance operations on unit, LOCK-OUT/TAGOUT the main power switch to unit. Electrical shock and rotating equipment could cause severe injury.

⚠ WARNING

ELECTRICAL OPERATION HAZARD

Failure to follow this warning could result in personal injury or death.

Units with convenience outlet circuits can use multiple disconnects. Check convenience outlet for power status before opening unit for service. Locate the disconnect switch and lock it in the open position it. LOCK-OUT/TAGOUT this switch to notify others.

⚠ WARNING

UNIT OPERATION AND SAFETY HAZARD

Failure to follow this warning could cause personal injury, death and/or equipment damage.

Puron (R-410A) refrigerant systems operate at higher pressures than standard R-22 systems. Do not use R-22 service equipment or components on Puron refrigerant equipment.

⚠ WARNING

FIRE, EXPLOSION HAZARD



Failure to follow this warning could result in death, serious personal injury and/or property damage.

Disconnect gas piping from unit when pressure testing at pressure greater than 0.5 psig. Pressures greater than 0.5 psig will cause gas valve damage resulting in hazardous condition. If gas valve is subjected to pressure greater than 0.5 psig, it *must* be replaced before use. When pressure testing field-supplied gas piping at pressures of 0.5 psig or less, a unit connected to such piping must be isolated by closing the manual gas valve(s).

⚠ WARNING

FIRE, EXPLOSION HAZARD



Failure to follow this warning could result in death, serious personal injury and/or property damage.

Never use air or gases containing oxygen for leak testing or for operating refrigerant compressors. Pressurized mixtures of air or gases containing oxygen can lead to an explosion.

⚠ WARNING

FIRE, EXPLOSION HAZARD



Failure to follow this warning could result in death, serious personal injury and/or property damage.

Never use non-certified refrigerants in this product. Non-certified refrigerants could contain contaminants that could lead to unsafe operating conditions. Use ONLY refrigerants that conform to AHRI Standard 700.

CAUTION

UNIT DAMAGE HAZARD

Failure to follow this caution may result in reduced unit performance or unit shutdown.

High velocity water from a pressure washer, garden hose, or compressed air should never be used to clean a coil. The force of the water or air jet will bend the fin edges and increase airside pressure drop.

NOTICE

OPERATIONAL TEST ALERT

Failure to follow this ALERT can result in an unnecessary evacuation of the facility.

Pressing the controller's test/reset switch for longer than seven seconds will put the duct detector into the alarm state and activate all automatic alarm responses.

UNIT ARRANGEMENT AND ACCESS

General

Fig. 1 and Fig. 2 show general unit arrangement and access locations.

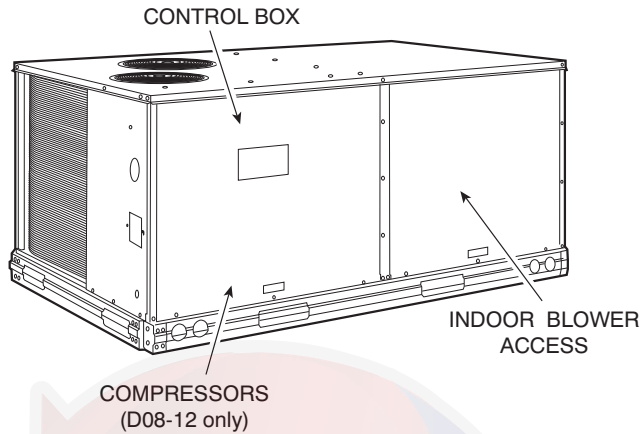

Fig. 1 – Typical Access Panel Location (Front)

C09190

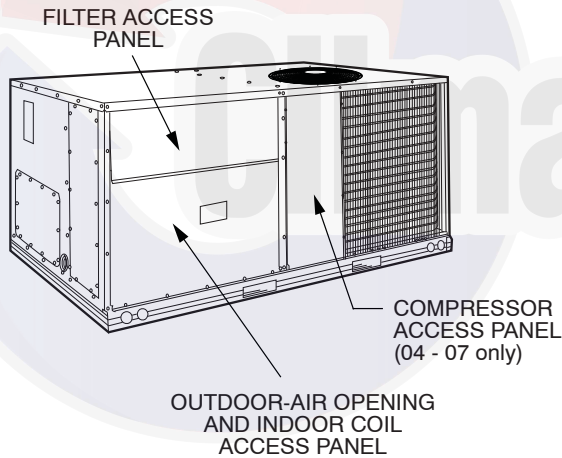

Fig. 2 – Typical Access Panel Locations (Rear)

C08449

Routine Maintenance

These items should be part of a routine maintenance program, to be checked every month or two, until a specific schedule for each can be identified for this installation:

Quarterly Inspection (and 30 days after initial start):

- Replace return air filter
- Clean outdoor hood inlet filters
- Check belt tension
- Check belt condition
- Inspect pulley alignment
- Check fan shaft bearing locking collar tightness
- Check outdoor coil cleanliness
- Check condensate drain

Seasonal Maintenance

The following items should be checked at the beginning of each season (or more often if local conditions and usage patterns dictate):

Air Conditioning/Heat Pump:

- Ensure outdoor fan motor mounting bolts are tight
- Ensure compressor mounting bolts are tight
- Inspect outdoor fan blade positioning
- Ensure control box is clean
- Check control box wiring condition
- Ensure wire terminals are tight
- Check refrigerant charge level
- Ensure indoor coils are clean
- Check supply blower motor amperage

Electric Heating:

- Inspect power wire connections
- Ensure fuses are operational
- Ensure manual–reset limit switch is closed

Economizer or Outside Air Damper

- Check inlet filters condition
- Check damper travel (economizer)
- Check gear and dampers for debris and dirt

Air Filters and Screens

Each unit is equipped with return air filters. If the unit has an economizer, it will also have an outside air screen. If a manual outside air damper is added, it will also have an inlet air screen.

Each of these filters and screens will need to be periodically cleaned or replaced.

RETURN AIR FILTERS:

CAUTION

EQUIPMENT DAMAGE HAZARD

Failure to follow this CAUTION can result in premature wear and damage to equipment.

DO NOT OPERATE THE UNIT WITHOUT THE RETURN AIR FILTERS IN PLACE.

Dirt and debris build-up on components can cause premature wear on components resulting in component failure.

Return Air Filters are disposable fiberglass filters. Access to the filters is through the lift-out filter access panel located on the rear side of the unit, above the indoor coil access panel. See Fig. 2.

Removing the Return Air Filters:

1. Grasp the bottom flange of the upper panel.
2. Lift up and swing the bottom out until the panel disengages and pulls out.
3. Reach inside and remove filters from the filter rack.
4. Replace filters as required with similar replacement filters of same size.

Re-installing the Access Panel:

1. Slide the top of the panel up under the unit top panel.
2. Slide the bottom into the side channels.
3. Push the bottom flange down until it contacts the top of the lower panel (or economizer top).

Outside Air Hood:

Outside Air Hood inlet screens are permanent aluminum-mesh type filters. Check these for cleanliness. Remove the screens when cleaning is required. Clean by washing with hot low-pressure water and soft detergent and replace all screens before restarting the unit. Observe the flow direction arrows on the side of each filter frame.

Economizer Inlet Air Screen:

This air screen is retained by filter clips under the top edge of the hood. See Fig. 3.

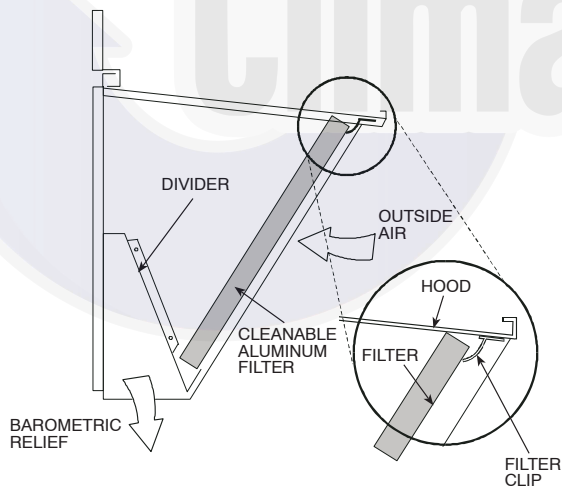

Fig. 3 – Filter Installation

C08634

To remove the filter, open the spring clips. Re-install the filter by placing the frame in its track, then closing the filter clips.

Manual Outside Air Hood Screen

The Manual Outside Air Hood Screen is secured by three screws and a retainer angle across the top edge of the hood. See Fig. 4.

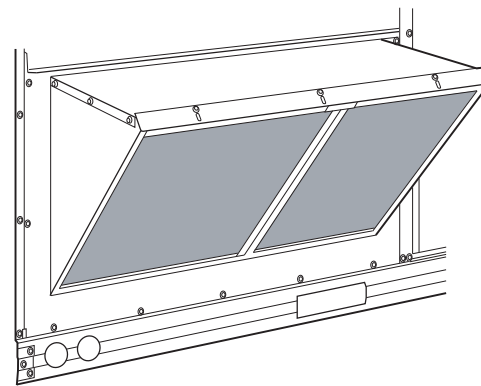

C07156

Fig. 4 – Screens Installed on Outdoor-Air Hood (Sizes A07, D08-09s Shown)

Remove the screen by loosening the three screws in the top retainer and move the retainer up until the filter can be removed.

Re-install the Manual Outside Air Hood Screen by placing the screen frame in its track, rotating the retainer back down. Tighten all screws.

SUPPLY FAN (BLOWER) SECTION

⚠ WARNING

ELECTRICAL SHOCK HAZARD

Failure to follow this warning can cause personal injury or death.

Before performing service or maintenance operations on the fan system, disconnect all electrical power to the unit and apply approved Lock-out/Tagout procedures to the unit disconnect switch. Do not reach into the fan section with power applied to unit.

Supply Fan (Direct-Drive)

For unit sizes 04, 05 and 06, a direct-drive forward-curved centrifugal blower wheel is an available option. The motor has taps to provide the servicer with the selection of one of five motor torque/speed ranges to best match wheel performance with attached duct system. See Fig. 5 (50TCQ Direct-Drive Fan Assembly) and Fig. 6 (ECM Motor Connectors).

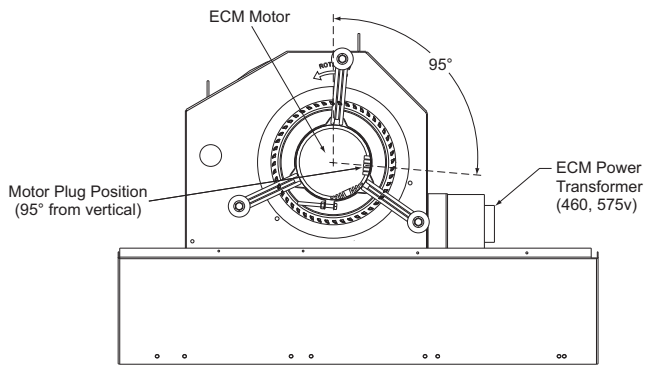

C09260

Fig. 5 - 50TCQ Direct-Drive Supply Fan Assembly

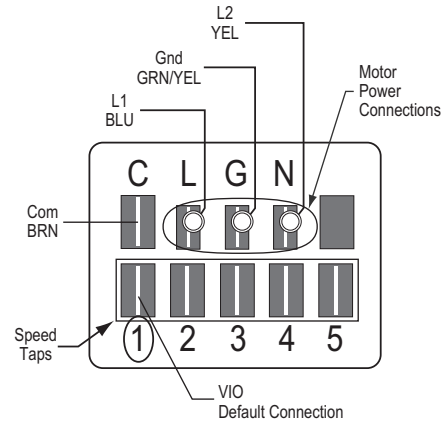

C09261

Fig. 6 - ECM Motor Connectors

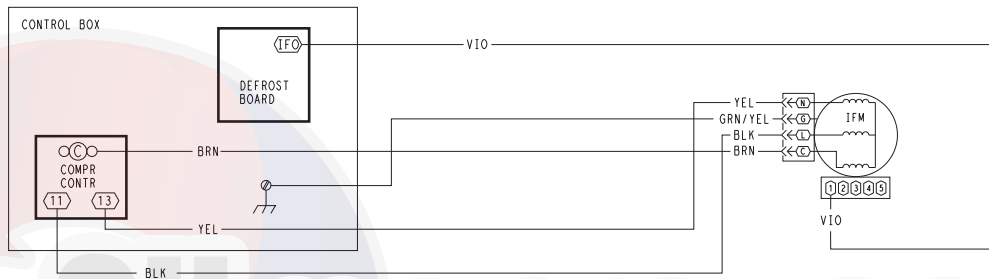

208/230, 460V Units

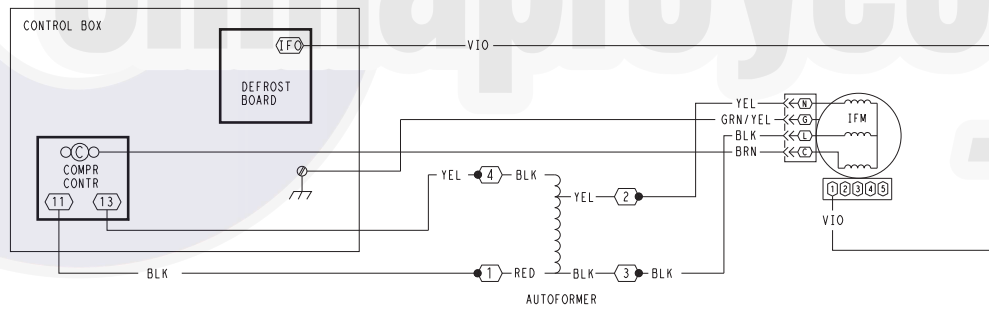

575V Units

Fig. 7 - ECM Unit Wiring

C09263

ECM Motor — The direct-drive motor is an X13 Electronically Commutated Motor (ECM). An ECM motor contains electronic circuitry used to convert single-phase line AC voltage into 3-phase DC voltage to power the motor circuit. The motor circuit is a DC brushless design with a permanent magnet rotor. On the X13 ECM Motor design, the electronic circuitry is integral to the motor assembly and cannot be serviced or replaced separately.

208/230V units use a 230V motor, 460V units use a 460V motor and 575V units use a 460V motor with an autotransformer. Motor power voltage is connected to motor terminals L and N (see Fig. 6 and Fig. 7); ground is connected at terminal G. The motor power voltage is ALWAYS present; it is not switched off by a motor contactor.

Motor operation is initiated by the presence of a 24V control signal to one of the five motor communications terminals. When the 24V signal is removed, the motor will stop. The motor control signal is switched by the defrost board's IFO output.

Evaluating motor speed — The X13 ECM Motor uses a constant torque motor design. The motor speed is adjusted by the motor control circuitry to maintain the programmed shaft torque. Consequently there is no specific speed value assigned to each control tap setting. At the Position 5 tap, the motor speed is approximately 1050 RPM (17.5 r/s) but varies depending on fan wheel loading.

Selecting speed tap — The five communication terminals are each programmed to provide a different motor torque output. See Table 1. Factory default tap selection is Position 1 for lowest torque/speed operation.

Table 1 – 50TCQ Motor Tap Programing (percent of full-load torque)

Unit Size	Tap 1	Tap 2	Tap 3	Tap 4	Tap 5
04	29	33	41	48	100
05	46	49	57	67	100
06	49	55	79	90	100

Factory Default: Tap 1 (VIO)

Selecting another speed:

1. Disconnect main power to the unit. Apply lockout/tagout procedures.
2. Remove the default motor signal lead (VIO) from terminal 1 at the motor communications terminal.
3. Reconnect the motor signal lead to the desired speed (terminals 1 through 5).
4. Connect main power to the unit.

Motor “rocking” on start-up — When the motor first starts, the rotor (and attached wheel) will “rock” back and forth as the motor tests for rotational direction. Once the correct rotational direction is determined by the motor circuitry, the motor will ramp up to the specified speed. The “rocking” is a normal operating characteristic of ECM motors.

Troubleshooting the ECM motor — Troubleshooting the

X13 ECM requires a voltmeter.

1. Disconnect main power to the unit.
2. Remove the motor power plug (including the control BRN lead) and VIO control signal lead at the motor terminals.
3. Restore main unit power.
4. Check for proper line voltage at motor power leads BLK (at L terminal) and YEL (at N terminal).

Table 2 – Motor Test Volts

Unit Voltage	Motor Voltage	Min–Max Volts
208/230	230	187–253
460	460	414–506
575	460	414–506

5. Using a jumper wire from unit control terminals R to G, engage motor operation. Check for 24v output at the defrost board terminal IFO.
6. Check for proper control signal voltages of 22V to 28V at motor signal leads VIO and BRN.
7. Disconnect unit main power. Apply lockout/tagout procedures.
8. Reconnect motor power and control signal leads at the motor terminals.
9. Restore unit main power.
10. The motor should start and run. If the motor does not start, remove the motor assembly. Replace the motor with one having the same part number. Do not substitute with an alternate design motor as the torque/ speed programming will not be the same as that on an original factory motor.

Replacing the X-13 ECM Motor — Before removing the ECM belly-band mounting ring from old motor:

1. Measure the distance from base of the motor shaft to the edge of the mounting ring.
2. Remove the motor mounting band and transfer it to the replacement motor.
3. Position the mounting band at the same distance that was measured in Step 1.
4. Hand-tighten mounting bolt only. Do not tighten securely at this time.
5. Insert the motor shaft into the fan wheel hub.
6. Securely tighten the three motor mount arms to the support cushions and torque the arm mounting screws to 60 in-lbs (6.8 Nm).
7. Center the fan wheel in the fan housing. Tighten the fan wheel hub setscrew and torque to 120 in-lbs (13.6 Nm).
8. Ensure the motor terminals are located at a position below the 3 o'clock position. See Fig. 5. Tighten the motor belly-band bolt and torque to 80 in-lbs (9.0 Nm).

Supply Fan (Belt-Drive)

The belt-drive supply fan system consists of a forward-curved centrifugal blower wheel on a solid shaft with two concentric type bearings, one on each side of the blower housing. A fixed-pitch driven pulley is attached to

the fan shaft and an adjustable-pitch driver pulley is on the motor. The pulleys are connected using a V-belt. See Fig. 8.

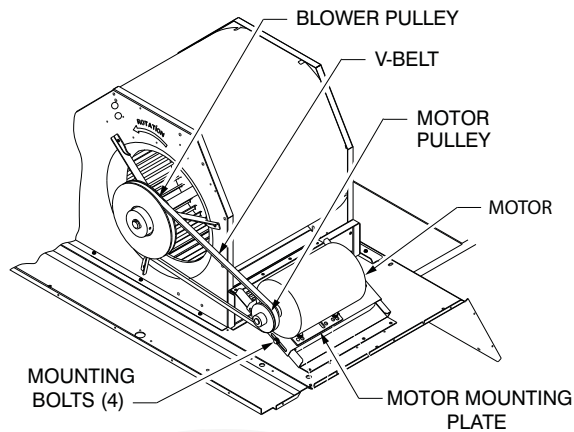

Fig. 8 – Typical Belt Drive Motor Mounting

C11504

Variable Frequency Drive (VFD)

For units equipped with a VFD factory installed option (FIOP), refer to the following supplement: “*Variable Frequency Drive (VFD) Installation, Setup and Troubleshooting.*”

Belt

Check the belt condition and tension quarterly. Inspect the belt for signs of cracking, fraying or glazing along the inside surfaces. Check belt tension by using a spring-force tool, such as Browning’s “Belt Tension Checker” (p/n: 1302546 or equivalent tool); tension should be 6-lbs at a $\frac{5}{8}$ -in (1.6 cm) deflection when measured at the centerline of the belt span. This point is at the center of the belt when measuring the distance between the motor shaft and the blower shaft.

NOTE: Without the spring-tension tool, place a straight edge across the belt surface at the pulleys, then push down on the belt at mid-span using one finger until a $\frac{1}{2}$ -in (1.3 cm) deflection is reached. See Fig. 9.

Adjust belt tension by loosening the motor mounting plate front and rear bolts and sliding the plate toward the fan (to reduce tension) or away from fan (to increase tension). Ensure the blower shaft and the motor shaft are parallel to each other (pulleys aligned). When finished, tighten all bolts and torque to 65–70 in-lb (7.4 to 7.9 Nm).

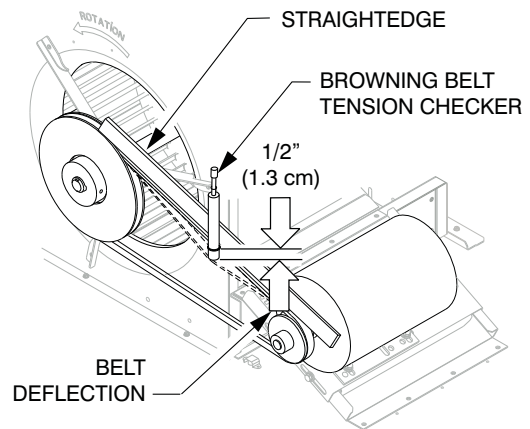

C12093

Fig. 9 – Checking Blower Motor Belt Tension

Replacing the Belt:

NOTE: Use a belt with same section type or similar size. Do not substitute a FHP-type belt. When installing the new belt, do not use a tool (screwdriver or pry-bar) to force the belt over the pulley flanges, this will stress the belt and cause a reduction in belt life. Damage to the pulley can also occur.

Use the following steps to replace the V-belt. See Fig. 8.

1. Loosen the front and rear motor mounting plate bolts.
2. Push the motor and its mounting plate towards the blower housing as close as possible to reduce the center distance between fan shaft and motor shaft.
3. Remove the belt by gently lifting the old belt over one of the pulleys.
4. Install the new belt by gently sliding the belt over both pulleys and then sliding the motor and plate away from the fan housing until proper tension is achieved.
5. Check the alignment of the pulleys, adjust if necessary.
6. Tighten all bolts and torque to 65–70 in-lb (7.4 to 7.9 Nm).
7. Check the tension after a few hours of runtime and re-adjust as required.

CAUTION

EQUIPMENT DAMAGE HAZARD

Failure to follow this CAUTION can result in premature wear and damage to equipment.

Do not use a screwdriver or a pry bar to place the new V-belt in the pulley groove. This can cause stress on the V-belt and the pulley resulting in premature wear on the V-belt and damage to the pulley.

Adjustable-Pitch Pulley on Motor:

The motor pulley is an adjustable-pitch type that allows a servicer to implement changes in the fan wheel speed to match as-installed ductwork systems. The pulley consists

of a fixed flange side that faces the motor (secured to the motor shaft) and a movable flange side that can be rotated around the fixed flange side that increases or reduces the pitch diameter of this driver pulley. See Fig. 10.

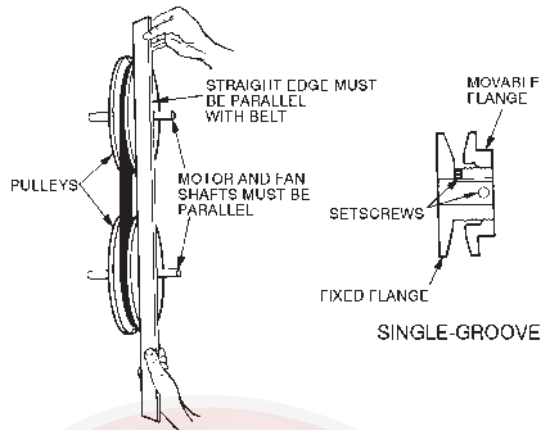

Fig. 10 – Supply-Fan Pulley Adjustment

C07075

As the pitch diameter is changed by adjusting the position of the movable flange, the centerline on this pulley shifts laterally (along the motor shaft). This creates a requirement for a realignment of the pulleys after any adjustment of the movable flange. Reset the belt tension after each realignment.

Inspect the condition of the motor pulley for signs of wear. Glazing of the belt contact surfaces and erosion on these surfaces are signs of improper belt tension and/or belt slippage. Replace pulley if wear is excessive.

Changing the Fan Speed:

1. Shut off unit power supply. Use proper lockout/tagout procedures.
2. Loosen belt by loosening fan motor mounting nuts. See Fig. 8.
3. Loosen movable pulley flange setscrew. See Fig. 10.
4. Screw movable flange toward fixed flange to increase speed and away from fixed flange to decrease speed. Increasing fan speed increases load on motor. Do not exceed the maximum specified speed.
5. Set movable flange at nearest keyway of pulley hub. Tighten setscrew and torque to 65–70 in–lb (7.4 to 7.9 Nm).

Aligning Blower and Motor Pulleys:

1. Loosen blower pulley setscrews.
2. Slide blower pulley along blower shaft. Make angular alignment by loosening motor mounting plate front and rear bolts.
3. Tighten blower pulley setscrews and motor mounting bolts. Torque bolts to 65–70 in–lb (7.4 to 7.9 Nm).
4. Recheck belt tension.

Bearings:

The fan system uses bearings featuring concentric split locking collars. A Torx T-25 socket head cap screw is used to tighten the locking collars. Tighten the locking collar by holding it tightly against the inner race of the

bearing. Tighten the socket head cap screw. Torque cap screw to 55–60 in–lb (6.2–6.8 Nm). See Fig. 11. Check the condition of the motor pulley for signs of wear. Glazing of the belt contact surfaces and erosion on these surfaces are signs of improper belt tension and/or belt slippage. Pulley replacement can be necessary.

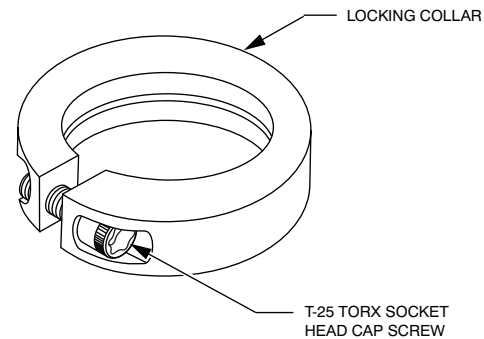

Fig. 11 – Tightening Locking Collar

C11505

Motor

When replacing the motor, also replace the external-tooth lock washer (star washer) under the motor mounting base; this is part of the motor grounding system. Ensure the teeth on the lock washer are in contact with the motor's painted base. Tighten motor mounting bolts and torque to 120 ± 12 in–lbs (14 ± 1.4 Nm).

Change fan wheel speed by changing the fan pulley (larger pitch diameter to reduce wheel speed, smaller pitch diameter to increase wheel speed) or select a new system (both pulleys and matching belt). The horsepower rating of the belt is primarily dictated by the pitch diameter of the smaller pulley in the drive system (typically the motor pulley in these units). Do not install a replacement motor pulley with a smaller pitch diameter than was provided on the original factory pulley.

Before changing pulleys to increase fan wheel speed, check the fan performance at the target speed and airflow rate to determine new motor loading (bhp). Use the fan performance tables or use the Packaged Rooftop Builder software program. Confirm that the motor in this unit is capable of operating at the new operating condition. Fan shaft loading increases dramatically as wheel speed is increased.

To reduce vibration, replace the motor's adjustable pitch pulley with a fixed pitch pulley (after the final airflow balance adjustment). This will reduce the amount of vibration generated by the motor/belt–drive system.

HEAT PUMP REFRIGERATION SYSTEM

⚠ WARNING

UNIT OPERATION AND SAFETY HAZARD

Failure to follow this warning could cause personal injury, death and/or equipment damage.

This system uses Puron[®] (R410A) refrigerant that operates at higher pressures than standard R-22 systems and other refrigerants. No other refrigerant can be used in this system. Gauge set, hoses, and recovery system must be designed to handle Puron refrigerant. If unsure about equipment, consult the equipment manufacturer.

Outdoor Coil

The 50TCQ outdoor coil is fabricated with round tube copper hairpins and plate fins of various materials and/or coatings (see “Appendix I – Model Number Significance” to identify the materials provided in this unit). All unit sizes use composite-type two-row coils. Composite two-row coils are two single-row coils fabricated with a single return bend end tubesheet.

Indoor Coil

The indoor coil is traditional round-tube, plate-fin technology. Tube and fin construction is of various optional materials and coatings (see Model Number Format). Coils are multiple-row.

Recommended Outdoor Coil Maintenance and Cleaning

Routine cleaning of coil surfaces is essential to maintain proper operation of the unit. Elimination of contamination and removal of harmful residues will greatly increase the life of the coil and extend the life of the unit. The following maintenance and cleaning procedures are recommended as part of the routine maintenance activities to extend the life of the coil.

Remove Surface Loaded Fibers:

Surface loaded fibers or dirt should be removed with a vacuum cleaner. If a vacuum cleaner is not available, a soft non-metallic bristle brush can be used. In either case, the tool should be applied in the direction of the fins. Coil surfaces can be easily damaged (fin edges can be easily bent over and damage the coating of a protected coil) when the tool is applied across the fins.

NOTE: Use of a water stream, such as a garden hose, against a surface loaded coil will drive the fibers and dirt into the coil. This will make cleaning efforts more difficult. Surface loaded fibers and dirt must be completely removed prior to using low velocity clean water rinse.

Periodic Clean Water Rinse:

A periodic clean water rinse is very beneficial for coils that are applied in coastal or industrial environments. However, it is very important that the water rinse is made with very low velocity water stream to avoid damaging the fin edges. Monthly cleaning as described below is recommended.

⚠ CAUTION

PERSONAL INJURY AND UNIT DAMAGE HAZARD

Failure to follow this caution can result in personal injury or equipment damage.

Only approved cleaning is recommended.

Routine Cleaning of Indoor Coil Surfaces:

Periodic cleaning with Totaline[®] Environmentally Sound Coil Cleaner is essential in extending the life of coils. This cleaner is available from Carrier Replacement Components Division (p/n P902-0301 for one gallon [3.8L] container, and p/n P902-0305 for a 5 gallon [19L] container). It is recommended that all coils (including standard aluminum, pre-coated, copper/copper or E-coated coils) be cleaned with the Totaline Environmentally Sound Coil Cleaner as described below. Coil cleaning should be part of the unit's regularly scheduled maintenance procedures ensuring the long life of the coil. Failure to clean the coils can result in reduced durability in the environment.

Avoid the use of:

- coil brighteners
- acid cleaning prior to painting
- high pressure washers
- poor quality water for cleaning

Totaline Environmentally Sound Coil Cleaner is non-flammable, hypoallergenic, non bacterial and a USDA accepted biodegradable agent that will not harm the coil or surrounding components, such as electrical wiring, painted metal surfaces or insulation. Use of non-recommended coil cleaners is strongly discouraged because coil and unit durability can be affected.

Clean coil as follows:

1. Turn off unit power. Use lockout/tagout procedures on unit power switch.
2. Remove top panel screws on outdoor coil end of unit.
3. Remove coil corner post. See Fig. 12. To hold top panel open, place coil corner post between top panel and center post. See Fig. 13.

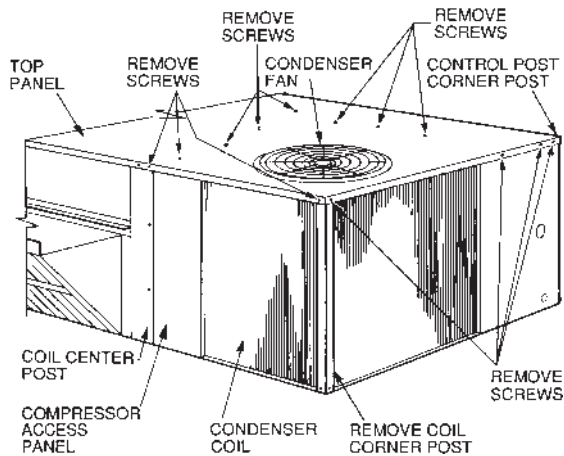

C07089

Fig. 12 – Cleaning Condenser Coil (Size 04–06 shown)

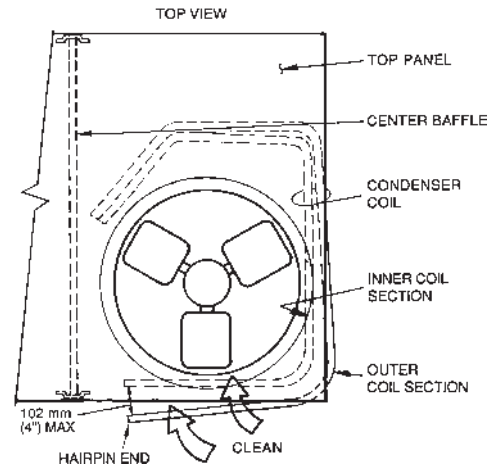

C08207

Fig. 14 – Separating Coil Sections

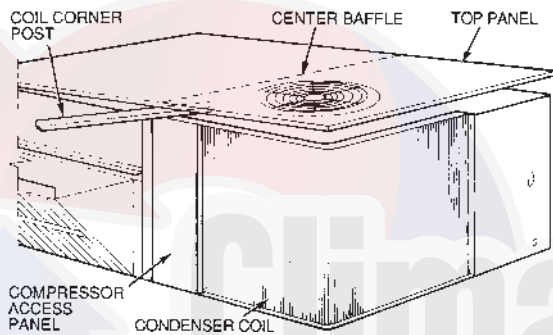

C08206

Fig. 13 – Propping Up Top Panel

4. For Sizes 04–06: Remove screws securing coil to compressor plate and compressor access panel.
5. For Sizes 07–14: Remove fastener holding coil sections together at return end of condenser coil. Carefully separate the outdoor coil section 3 to 4 in. (7.6–10 cm) from the inner coil section. See Fig. 14.
6. Clean the outer surfaces with a stiff brush in the normal manner. Use a water hose or other suitable equipment to flush down between the 2 coil sections to remove dirt and debris.
7. Secure inner and outer coil rows together with a field-supplied fastener.
8. Reposition the outer coil section and remove the coil corner post from between the top panel and center post. Reinstall the coil corner post and replace all screws.

Totaline Environmentally Sound Coil Cleaner Application Equipment:

- 2.5 gal (9.5L) garden sprayer
- Water rinse with low velocity spray nozzle

CAUTION

UNIT DAMAGE HAZARD

Failure to follow this caution can result in corrosion and damage to the unit.

Harsh chemicals, household bleach, acid or basic cleaners should not be used to clean outdoor or indoor coils of any kind. These cleaners can be very difficult to rinse out of the coil and can accelerate corrosion at the fin/tube interface where dissimilar materials are in contact. If there is dirt below the surface of the coil, use the Totaline Environmentally Sound Coil Cleaner as described below.

CAUTION

UNIT DAMAGE HAZARD

Failure to follow this caution can result in reduced unit performance.

High velocity water from a pressure washer, garden hose, or compressed air should never be used to clean a coil. The force of the water or air jet will bend the fin edges and increase airside pressure drop.

Totaline Environmentally Sound Coil Cleaner Application Instructions:

1. Proper protection equipment, such as approved safety glasses and gloves, is recommended during mixing and application of Totaline Environmentally Sound Coil Cleaner.
2. Remove all surface loaded fibers and debris using a vacuum cleaner or a soft non-metallic bristle brush as described above.
3. Thoroughly wet all finned surfaces with clean water using a low velocity garden hose being careful not to bend fins.
4. Mix Totaline Environmentally Sound Coil Cleaner in a 2.5 gal (9.5L) garden sprayer according to the

instructions included with the cleaner. The optimum solution temperature is 100°F (38°C).

NOTE: Do NOT USE water in excess of 130°F (54°C), as the enzymatic activity will be destroyed.

5. Thoroughly apply Totaline Environmentally Sound Coil Cleaner solution to all coil surfaces including finned area, tube sheets and coil headers.
6. Hold garden sprayer nozzle close to finned areas and apply cleaner with a vertical, up-and-down motion. Avoid spraying in horizontal pattern to minimize potential for fin damage.
7. Ensure cleaner thoroughly penetrates deep into finned areas.
8. Interior and exterior finned areas must be thoroughly cleaned.
9. Finned surfaces should remain wet with cleaning solution for 10 minutes.
10. Ensure surfaces are not allowed to dry before rinsing. Reapply cleaner as needed to ensure 10-minute saturation is achieved.
11. Thoroughly rinse all surfaces with low velocity clean water using downward rinsing motion of water spray nozzle. Protect fins from damage from the spray nozzle.

Indoor Coil

Cleaning the Indoor Coil:

1. Turn unit power off. Use proper lockout/tagout procedures.
2. Remove indoor coil access panel.

3. If economizer or two-position damper is installed, remove economizer by disconnecting the Molex® plug and removing mounting screws.
4. Slide filters out of unit.
5. Clean coil using a commercial coil cleaner or dishwasher detergent in a pressurized spray canister. Wash both sides of coil and flush with clean water. For best results, back-flush toward return-air section to remove foreign material. Flush condensate pan after completion.
6. Reinstall economizer and filters.
7. Reconnect wiring.
8. Replace access panels.

Refrigeration System Components:

Each heat pump refrigeration system includes a compressor, accumulator, reversing valve, dual-function outdoor coil with vapor header check valve, cooling liquid line with a filter drier and a check valve, dual-function indoor coil with a vapor header check valve, and heating liquid line with check a valve and a strainer. Unit sizes A04-07 have a single compressor-circuit; unit sizes D08 through D12 have two compressor-circuits. See Fig. 15 for typical unit piping schematic (unit size D09 (4-row indoor coil) with two compressor-circuits is shown).

Dual-function outdoor and indoor coils are designed to provide parallel coil circuits during evaporator-function operation and converging coil circuits during the condenser-function operation.

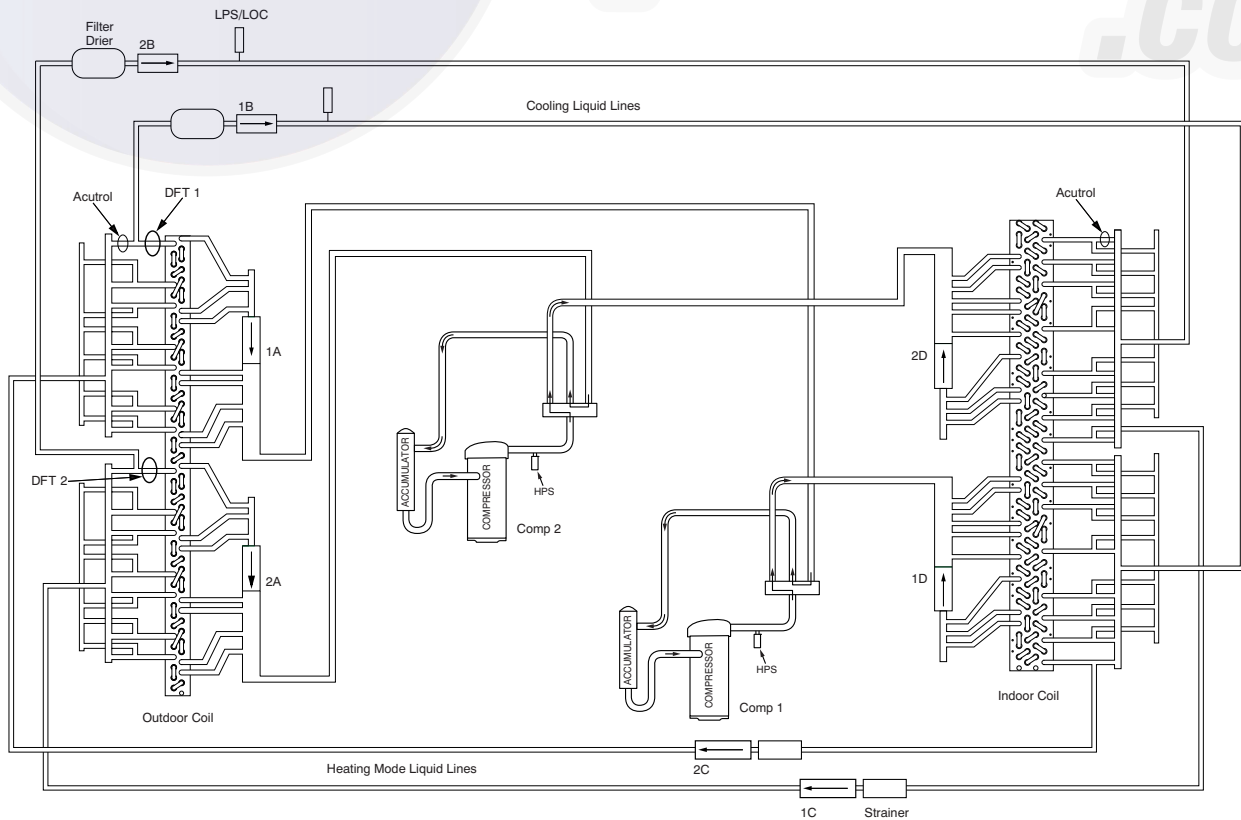

Fig. 15 – Typical Unit Piping Schematic (with TXV valves on Indoor Coils)

C09228

Reversing Valve and Check Valve Position

See Fig. 15 on page 11.

Table 3 – Cooling Mode (each circuit)

Component	Status/Position
Reversing Valve	Energized
Check Valve A	Closed
Check Valve B	Open
Check Valve C	Closed
Check Valve D	Open

Table 4 – Heating Mode (each circuit)

Component	Status/Position
Reversing Valve	De-energized
Check Valve A	Open
Check Valve B	Closed
Check Valve C	Open
Check Valve D	Closed

Table 5 – Defrost Mode

A04–A07 and D08–D14/Circuit 2:

Component	Status/Position
Defrost Thermostat	Closed
Outdoor Fan(s)	Off
Reversing Valve	Energized
Check Valve A	Closed
Check Valve B	Open
Check Valve C	Closed
Check Valve D	Open

Troubleshooting Refrigerant Pressure Problems and Check Valves

Refer to Fig. 15, above, and the Cooling Mode and Heating Mode tables (Tables 3 and 4) above.

Refrigerant System Pressure Access Ports

There are two access ports in each circuit – on the suction tube and the discharge tube near the compressor. These are brass fittings with black plastic caps. The hose connection fittings are standard 1/4 SAE male flare couplings.

The brass fittings are two-piece High Flow valves, with a receptacle base brazed to the tubing and an integral spring-closed check valve core screwed into the base. See Fig. 16. This check valve is permanently assembled into this core body and cannot be serviced separately. Replace the entire core body if necessary. Service tools are available from RCD that allow the replacement of the check valve core without having to recover the entire system refrigerant charge. Apply compressor refrigerant oil to the check valve core's bottom O-ring. Install the fitting body and torque to 96 ± 10 in-lbs (10.9 ± 1 Nm). Do not exceed 106 in-lbs (11.9 Nm) when tightening.

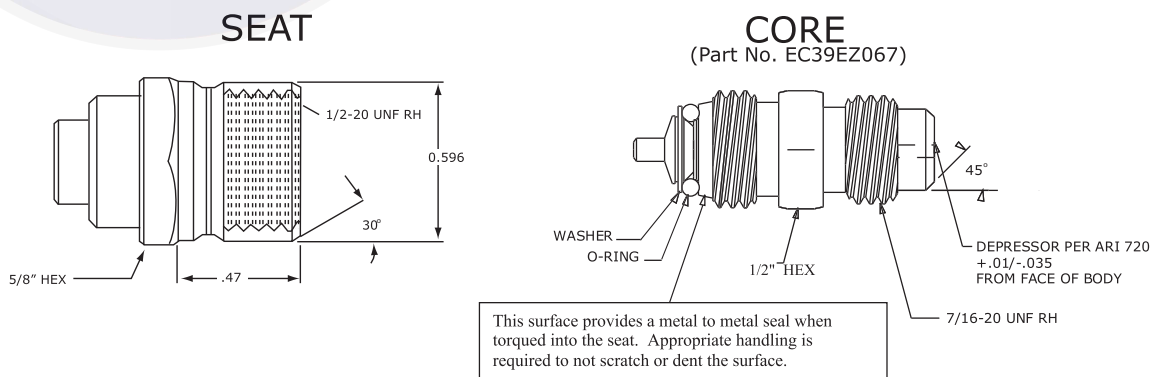

Fig. 16 – CoreMax Access Port Assembly

C08453

PURON® (R-410A) REFRIGERANT

This unit is designed for use with Puron (R-410A) refrigerant. Do not use any other refrigerant in this system.

Puron (R-410A) refrigerant is provided in pink (rose) colored cylinders. These cylinders are available with and without dip tubes; cylinders with dip tubes will have a label indicating this feature. For a cylinder with a dip

tube, place the cylinder in the upright position (access valve at the top) when removing liquid refrigerant for charging. For a cylinder without a dip tube, invert the cylinder (access valve on the bottom) when removing liquid refrigerant.

Because Puron (R-410A) refrigerant is a blend, it is strongly recommended that refrigerant always be removed from the cylinder as a liquid. Add liquid refrigerant into the system in the discharge line. If adding refrigerant into

the suction line, use a commercial metering/expansion device at the gauge manifold; remove liquid from the cylinder, pass it through the metering device at the gauge set and then pass it into the suction line as a vapor. Do not remove Puron (R-410A) refrigerant from the cylinder as a vapor.

Refrigerant Charge

The amount of refrigerant charge is listed on the unit's nameplate. Refer to Carrier Publication, "GTAC2-5 Charging, Recovery, Recycling and Reclamation Training Manual" and the following procedures:

Unit panels must be in place when unit is operating during the charging procedure. If unit is equipped with a head pressure control device, bypass it to ensure full fan operation during charging.

Charge checking and adjustments must be made while the system is operating in Cooling only.

No Charge:

Use standard evacuation techniques for Puron (R-410A) refrigerant.. After evacuating system, weigh the specified amount of refrigerant.

THERMOSTATIC EXPANSION VALVE (TXV)

All 50TCQ's have a factory installed nonadjustable thermostatic expansion valve (TXV). The TXV will be a bi-flow, bleed port expansion valve with an external equalizer. TXVs are specifically designed to operate with Puron® refrigerant, use only factory authorized TXVs. See Fig. 15 for a typical piping schematic.

TXV Operation

The TXV is a metering device that is used in air conditioning and heat pump systems to adjust to changing load conditions by maintaining a preset superheat temperature at the outlet of the evaporator coil. The volume of refrigerant metered through the valve seat is dependent upon the following (see Fig. 17):

1. Superheat temperature is sensed by the cap tube sensing bulb on the suction tube at outlet of the evaporator coil. This temperature is converted into pressure by refrigerant in the bulb pushing downward on the diaphragm which opens the valve using the push rods. As long as this bulb and cap tube contain any liquid refrigerant, this temperature is converted into suction pressure pushing downward on the diaphragm, which tends to open the TXV valve through the push rods.
2. The suction pressure at the outlet of the evaporator coil is transferred through the external equalizer tube to the underside of the diaphragm.
3. The needle valve on the pin carrier is spring loaded, exerting pressure on the underside of the diaphragm. Therefore, the bulb pressure equals evaporator pressure (at outlet of coil) plus spring pressure. If the load increases, the temperature increases at the bulb, which increases the pressure on the top side of the diaphragm, pushing the carrier away from the seat, opening the valve and increasing the flow of refrigerant. The increased refrigerant flow causes increased leaving evaporator pressure which is transferred through the equalizer tube to the underside of the diaphragm. This causes pin carrier spring pressure to close the TXV valve. The refrigerant flow is effectively stabilized to the load demand with a negligible change in superheat.

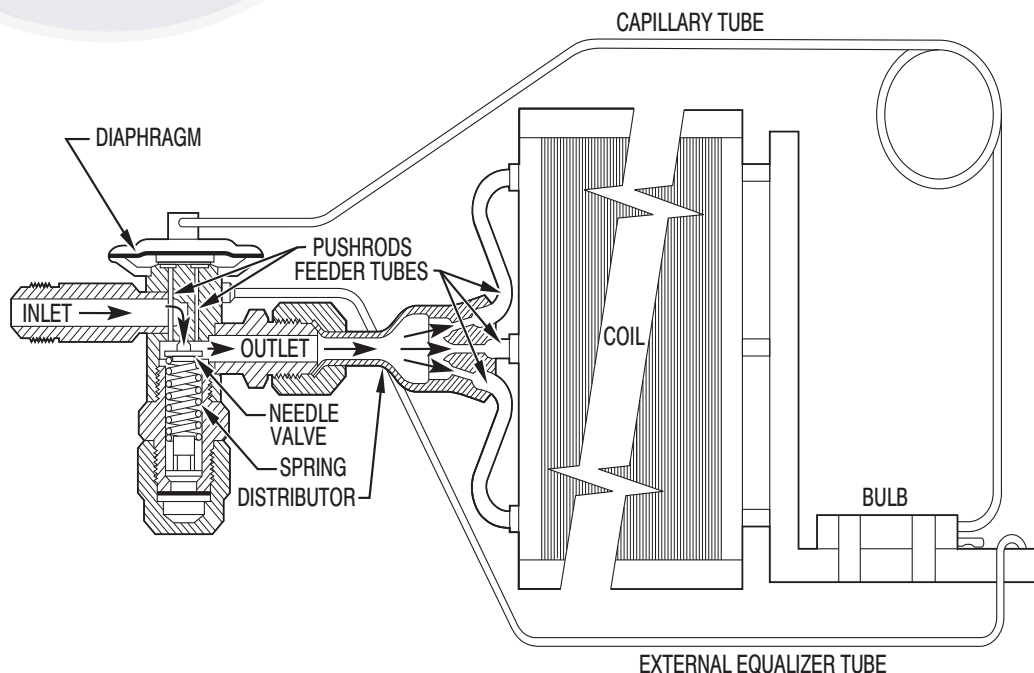

Fig. 17 – Thermostatic Expansion Valve (TXV) Operation

C12046

Replacing TXV

⚠ CAUTION

PERSONAL INJURY HAZARD

Failure to follow this caution can result in injury to personnel and damage to components.

Always wear approved safety glasses, work gloves and other recommended Personal Protective Equipment (PPE) when working with refrigerants.

1. Recover refrigerant.
2. Remove TXV support clamp using a 5/16-in. nut driver.
3. Remove TXV using a backup wrench on connections to prevent damage to tubing.
4. Remove equalizer tube from suction line of coil. Use file or tubing cutter to cut brazed equalizer line approximately 2 inches above suction tube.
5. Remove bulb from vapor tube inside cabinet.
6. Install the new TXV and avoid damaging the tubing or the valve when attaching the TXV to the distributor.
7. Attach equalizer tube to suction line. If coil has mechanical connection, then use wrench and back up wrench to attach. If coil has brazed connection, use file or tubing cutters to remove mechanical flare nut from equalizer line. Then use coupling to braze the equalizer line to stub (previous equalizer line) in suction line.
8. Attach TXV bulb in the same location as original (in the sensing bulb indent), wrap bulb in protective insulation and secure using the supplied bulb clamp. See Fig. 18.
9. Route equalizer tube through suction connection opening (large hole) in fitting panel and install fitting panel in place.
10. Sweat inlet of TXV marked "IN" to liquid line. Avoid excessive heat which could damage valve.

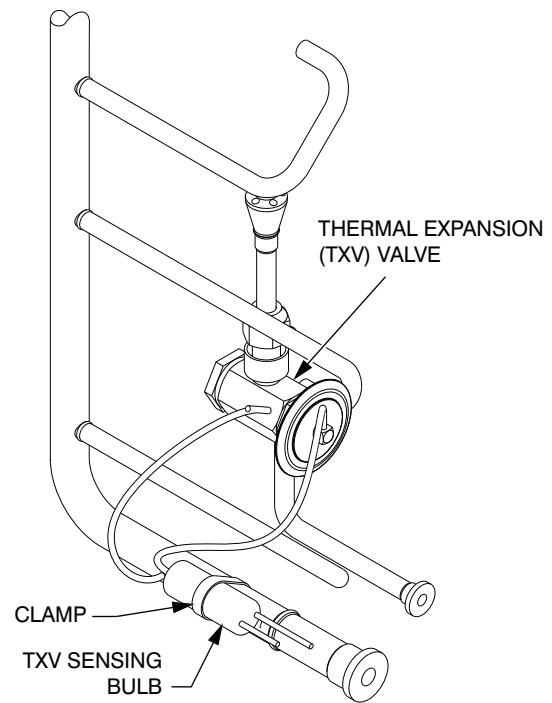

SENSING BULB INSULATION REMOVED FOR CLARITY

C12095

Fig. 18 – TXV Valve and Sensing Bulb

COOLING CHARGING CHARTS

How To Use Cooling Charging Charts:

Take the outdoor ambient temperature and read the suction pressure gauge. Refer to chart to determine what suction temperature should be. If suction temperature is high, add refrigerant. If suction temperature is low, carefully recover some of the charge. Recheck the suction pressure as charge is adjusted.

SIZE DESIGNATION	NOMINAL TONS REFERENCE
A04	3
A05	4
A06	5
A07	6
D08	7.5
D09	8.5
D12	10
D14	12.5

EXAMPLE:

Model 50TCQ*D14

Outdoor Temperature 85°F (29°C)

Suction Pressure 140 psig (965 kPa)

Suction Temperature 55° F (13°C)

Refer to Fig. 19 through Fig. 26 for Cooling Charging Charts.

Compressors

Lubrication:

Compressors are charged with the correct amount of oil at the factory.

CAUTION

UNIT DAMAGE HAZARD

Failure to follow this caution can result in damage to components.

The compressor is in a Puron (R-410A) refrigerant system and uses a polyolester (POE) oil. This oil is extremely hygroscopic, meaning it absorbs water readily. POE oils can absorb 15 times as much water as other oils designed for HCFC and CFC refrigerants. Avoid exposure of POE oil to the atmosphere. This exposure to the atmosphere can cause contaminants that are harmful to R-410A components to form. Keep POE oil containers closed until ready for use.

COOLING CHARGING CHARTS

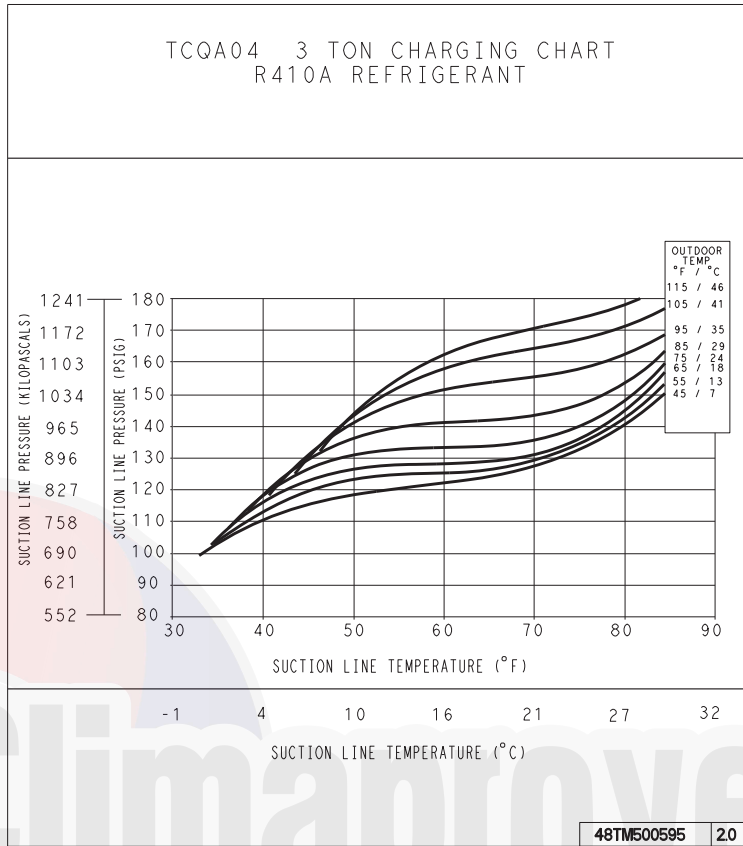

Fig. 19 – Cooling Charging Charts– 50TCQA04

C09184

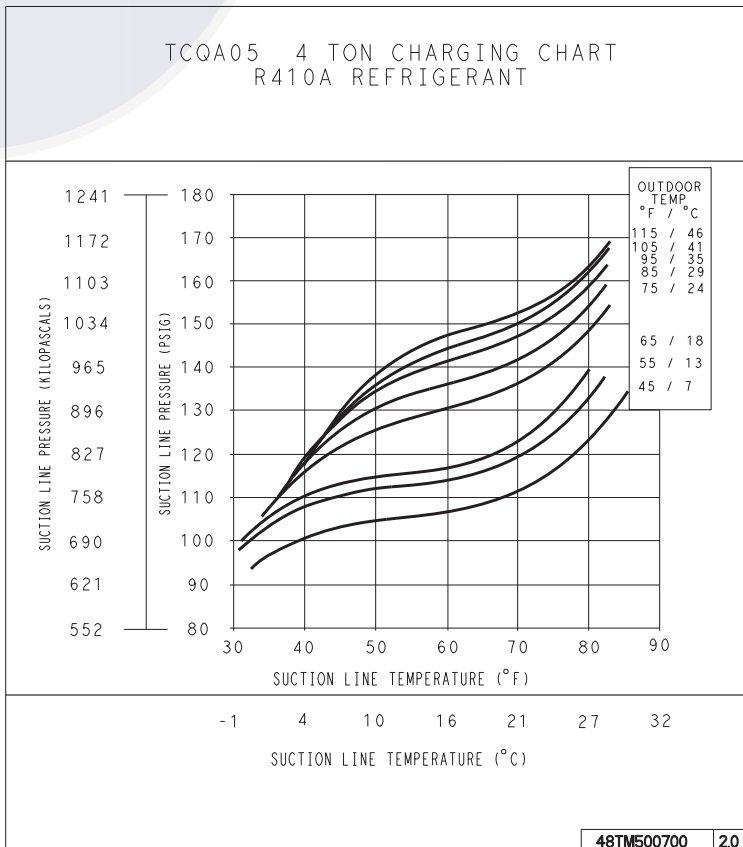

Fig. 20 – Cooling Charging Charts – 50TCQA05

C09185

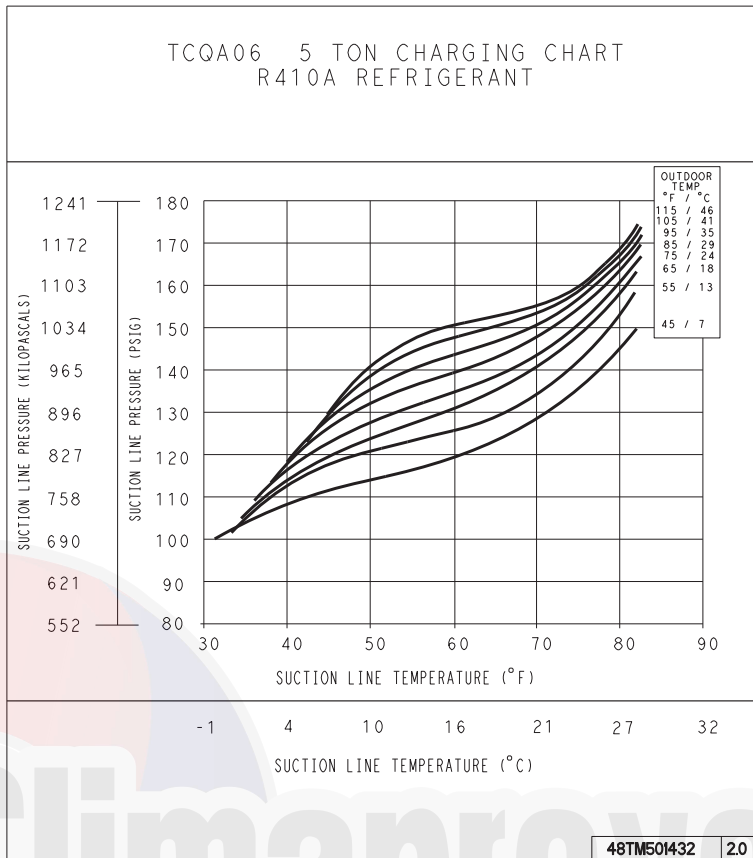

Fig. 21 – Cooling Charging Charts – 50TCQA06

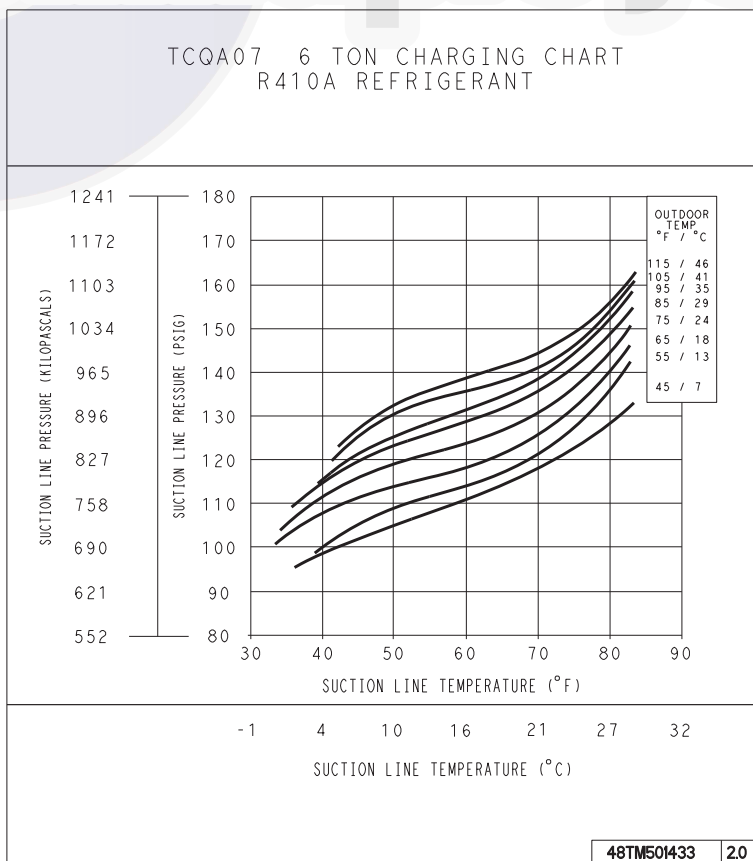

Fig. 22 – Cooling Charging Charts – 50TCQA07

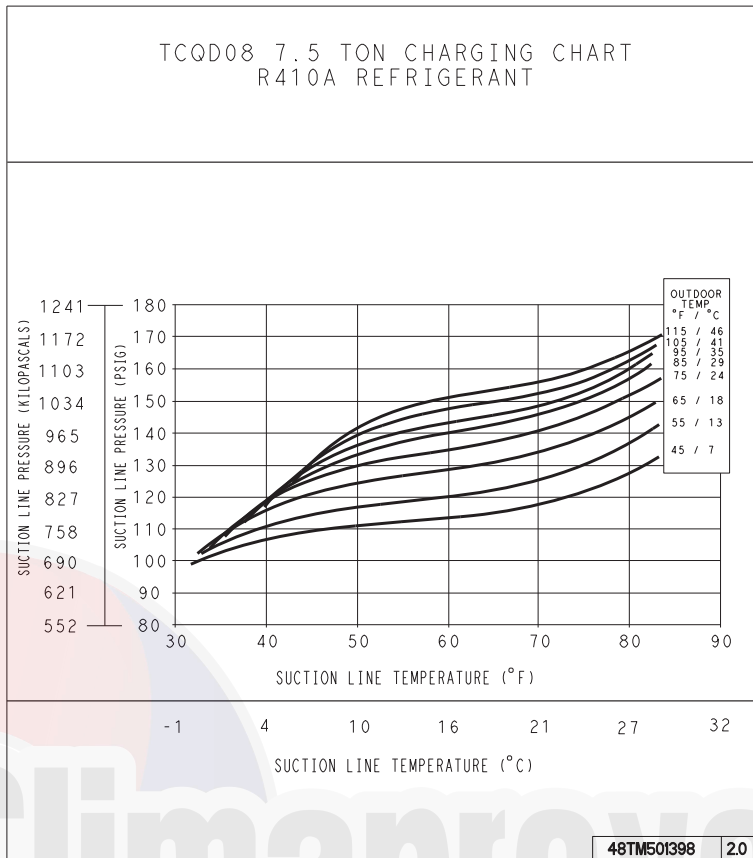

Fig. 23 – Cooling Charging Charts – 50TCQD08

C09188

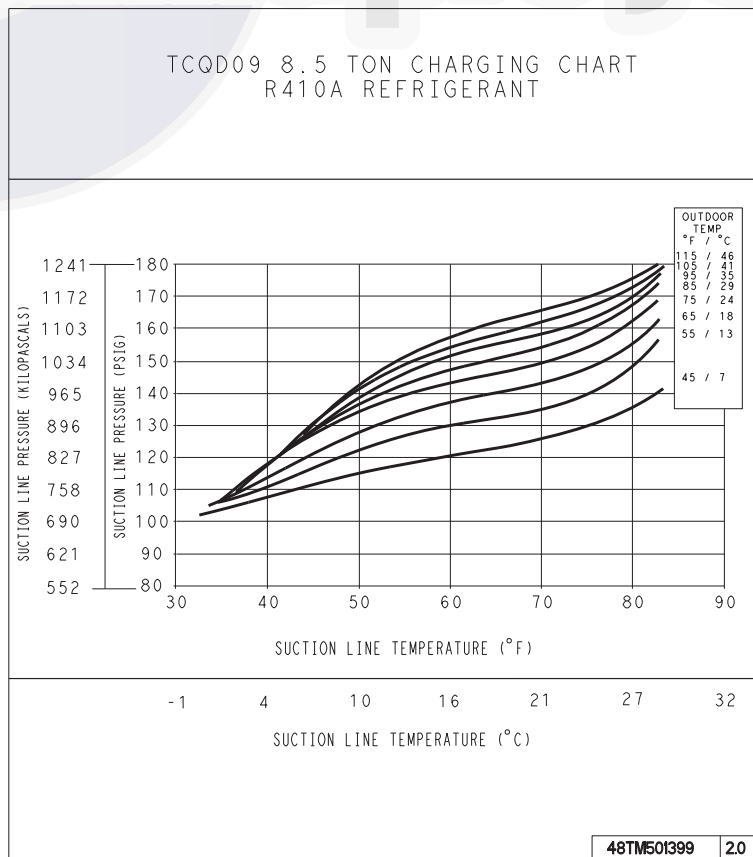

Fig. 24 – Cooling Charging Charts – 50TCQD09

C09189

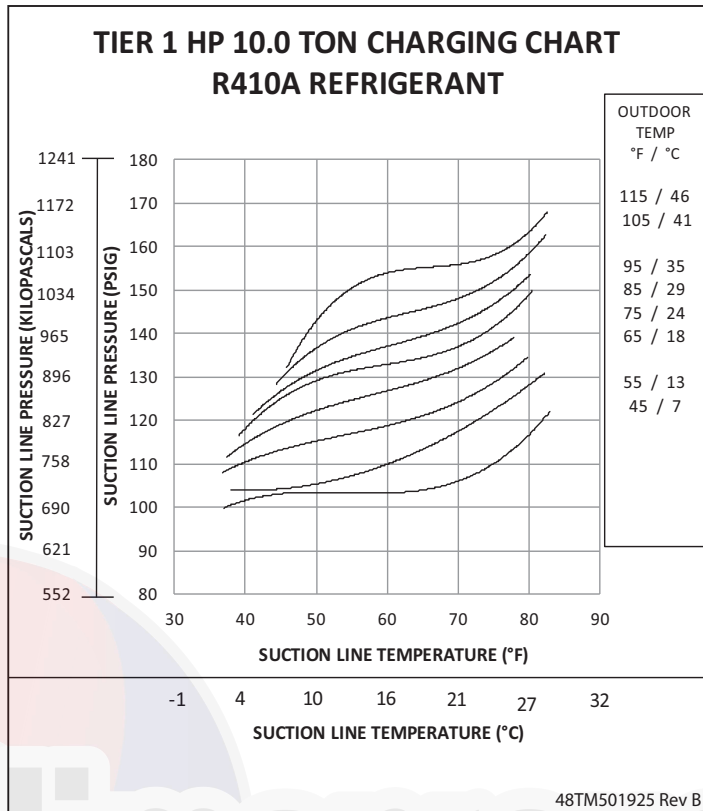

Fig. 25 – Cooling Charging Charts – 50TCQD12

C150381

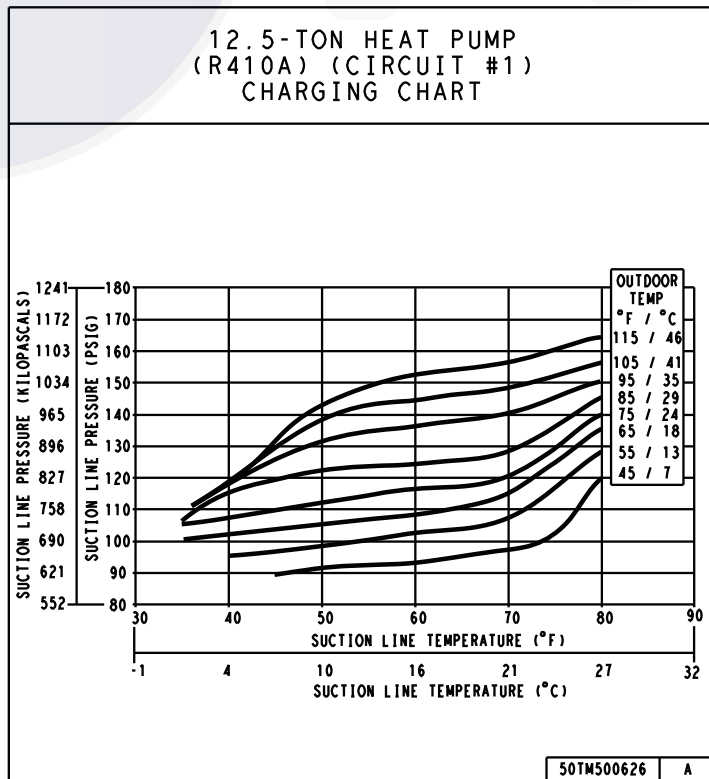

Fig. 26 – Cooling Charging Charts – 50TCQD14, Circuit 1

C150382

12.5-TON HEAT PUMP
(R410A) (CIRCUIT #2)
CHARGING CHART



Fig. 27 – Cooling Charging Charts – 50TCQD14, Circuit 2

C150383

Replacing the Compressor

⚠ WARNING

FIRE, EXPLOSION HAZARD



Failure to follow this warning could result in death, serious personal injury and/or property damage.

Never use air or gases containing oxygen for leak testing or for operating refrigerant compressors. Pressurized mixtures of air or gases containing oxygen can lead to an explosion.

CAUTION

INSTALLATION SITE DAMAGE

Failure to follow this caution can result in damage to equipment location site.

- Puron (R-410A) refrigerant contains polyolester (POE) oil that can damage the roof membrane. Caution should be taken to prevent POE oil from spilling onto the roof surface.
- The factory also recommends that the suction and discharge lines be cut with a tubing cutter instead of using a torch to remove brazed fittings.

NOTE: Only factory-trained service technicians should remove and replace compressor units.

Compressors using Puron refrigerant contain a polyolester (POE) oil. This oil has a high affinity for moisture. Do not remove the compressor's tube plugs until ready to insert the unit suction and discharge tube ends.

Compressor Rotation:

CAUTION

EQUIPMENT DAMAGE

Failure to follow this caution can result in equipment damage.

Scroll compressors can only compress refrigerant if rotating in the right direction. Reverse rotation for extended times can result in internal damage to the compressor. Scroll compressors are sealed units and cannot be repaired on site location.

NOTE: When the compressor is rotating in the wrong direction, the unit makes an elevated level of noise and does not provide cooling.

On 3-phase units with scroll compressors, it is important to be certain compressor is rotating in the proper direction. To determine whether or not compressor is rotating in the proper direction:

1. Connect service gauges to suction and discharge pressure fittings.

2. Energize the compressor.
3. The suction pressure should drop and the discharge pressure should rise, as is normal on any start-up.

NOTE: If the suction pressure does not drop and the discharge pressure does not rise to normal levels:

4. Note that the evaporator fan is probably also rotating in the wrong direction.
5. Turn off power to the unit.
6. Reverse any two of the three unit power leads.
7. Reapply electrical power to the compressor.
8. The suction pressure should drop and the discharge pressure should rise which is normal for scroll compressors on start-up.
9. Replace compressor if suction/discharge pressures are not within specifications for the specific compressor.

Filter Drier

Replace the Filter Drier whenever refrigerant system is exposed to atmosphere. Only use factory specified liquid-line filter driers with working pressures no less than 650 psig (4482 kPa).

CAUTION

EQUIPMENT DAMAGE

Failure to follow this caution can result in equipment damage.

Do not install a suction-line filter drier in liquid line. A liquid-line filter drier designed for use with Puron refrigerant is required on every unit.

Outdoor Fan Location

See Fig. 28.

1. Shut off unit power supply. Apply lockout/tagout procedures.
2. Remove condenser-fan assembly (grille, motor, and fan).
3. Loosen fan hub setscrews.
4. Adjust fan height as shown in Fig. 28.
5. Tighten setscrews to 84 in-lbs (9.5 Nm).
6. Replace condenser-fan assembly.

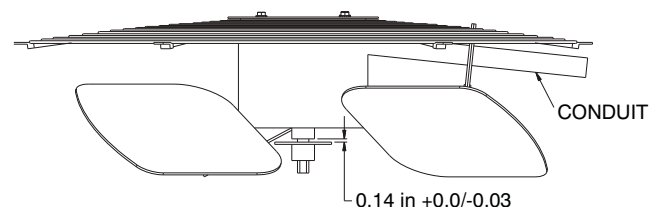

C08448

Fig. 28 – Outdoor Fan Adjustment

Troubleshooting Cooling System

Refer to Table 6, on the following page, for additional troubleshooting topics.

Table 6 – Heating and Cooling Troubleshooting

PROBLEM	CAUSE	REMEDY
Compressor and Outdoor Fan Will Not Start.	Power failure.	Call power company.
	Fuse blown or circuit breaker tripped.	Replace fuse or reset circuit breaker. Determine root cause.
	Defective thermostat, contactor, transformer, control relay, or capacitor.	Replace component.
	Insufficient line voltage.	Determine cause and correct.
	Incorrect or faulty wiring.	Check wiring diagram and rewire correctly.
	Thermostat setting too high.	Lower thermostat setting below room temperature.
	High pressure switch tripped.	See problem "Excessive head pressure."
	Low pressure switch tripped.	Check system for leaks. Repair as necessary.
Compressor Will Not Start But Outdoor Fan Runs.	Freeze-up protection thermostat tripped.	See problem "Suction pressure too low."
	Faulty wiring or loose connections in compressor circuit.	Check wiring and repair or replace.
	Compressor motor burned out, seized, or internal overload open.	Determine cause. Replace compressor or allow enough time for internal overload to cool and reset.
	Defective run/start capacitor, overload, start relay.	Determine cause and replace compressor.
Compressor Cycles (Other Than Normally Satisfying Thermostat).	One leg of 3-phase power dead.	Replace fuse or reset circuit breaker. Determine cause.
	Refrigerant overcharge or undercharge.	Recover refrigerant, evacuate system, and recharge to nameplate.
	Defective compressor.	Replace and determine cause.
	Insufficient line voltage.	Determine cause and correct.
	Blocked outdoor coil or dirty air filter.	Determine cause and correct.
	Defective run/start capacitor, overload, or start relay.	Determine cause and replace.
	Defective thermostat.	Replace thermostat.
Compressor Operates Continuously.	Faulty outdoor-fan (cooling) or indoor-fan (heating) motor or capacitor.	Replace.
	Restriction in refrigerant system.	Locate restriction and remove.
	Dirty air filter.	Replace filter.
	Unit undersized for load.	Decrease load or increase unit size.
	Thermostat set too low (cooling).	Reset thermostat.
	Low refrigerant charge.	Locate leak; repair and recharge.
Compressor Makes Excessive Noise.	Air in system.	Recover refrigerant, evacuate system, and recharge.
	Outdoor coil dirty or restricted.	Clean coil or remove restriction.
	Compressor rotating in the wrong direction.	Reverse the 3-phase power leads as described in Start-Up.
	Dirty outside air or return air filter (heating).	Replace filter.
	Dirty outdoor coil (cooling).	Clean coil.
Excessive Head Pressure.	Refrigerant overcharged.	Recover excess refrigerant.
	Air in system.	Recover refrigerant, evacuate system, and recharge.
	Condensing air restricted or air short-cycling.	Determine cause and correct.
	Low refrigerant charge.	Check for leaks; repair and recharge.
Head Pressure Too Low.	Compressor scroll plates defective.	Replace compressor.
	Restriction in liquid tube.	Remove restriction.
	High heat load.	Check for source and eliminate.
Excessive Suction Pressure.	Compressor scroll plates defective.	Replace compressor.
	Refrigerant overcharged.	Recover excess refrigerant.
	Dirty air filter (cooling).	Replace filter.
Suction Pressure Too Low.	Dirty or heavily iced outdoor coil (heating).	Clean outdoor coil. Check defrost cycle operation.
	Low refrigerant charge.	Check for leaks; repair and recharge.
	Metering device or low side restricted.	Remove source of restriction.
	Insufficient indoor airflow (cooling mode).	Increase air quantity. Check filter and replace if necessary.
	Temperature too low in conditioned area.	Reset thermostat.
	Field-installed filter drier restricted.	Replace.
	Outdoor ambient below 25°F (cooling).	Install low-ambient kit.
	Outdoor fan motor(s) not operating (heating).	Check fan motor operation.

CONVENIENCE OUTLETS

⚠ WARNING

ELECTRICAL OPERATION HAZARD

Failure to follow this warning could result in personal injury or death.

Units with convenience outlet circuits can use multiple disconnects. Check convenience outlet for power status before opening unit for service. Locate its disconnect switch, if appropriate, and open it. Apply lockout/tagout to this switch, if necessary.

Convenience Outlets: Two types of convenience outlets are offered on 50TCQ models: Non-powered and unit-powered. Both types provide a 125VAC/15A Ground-Fault Circuit Interrupter (GFCI) duplex receptacle behind a hinged waterproof access cover, located on the end panel of the unit. See Fig. 29.

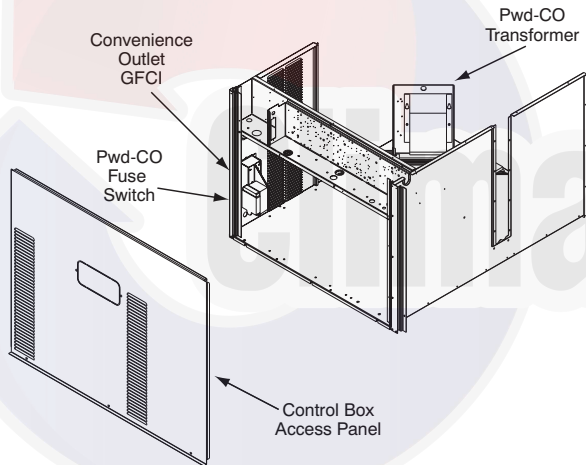

Fig. 29 – Convenience Outlet Location

C08128

Installing Weatherproof Cover —

A weatherproof while-in-use cover for the factory installed convenience outlets is now required by UL standards. This cover cannot be factory-mounted due its depth. The cover must be installed at unit installation. For shipment, the convenience outlet is covered with a blank cover plate.

The weatherproof cover kit is shipped in the unit's control box. The kit includes the hinged cover, a backing plate and gasket.

NOTE: DISCONNECT ALL POWER TO UNIT AND CONVENIENCE OUTLET. Use approved lockout/tagout procedures.

1. Remove the blank cover plate at the convenience outlet; discard the blank cover.
2. Loosen the two screws at the GFCI duplex outlet, until approximately $\frac{1}{2}$ -in (13 mm) under screw heads are exposed.
3. Press the gasket over the screw heads. Slip the backing plate over the screw heads at the keyhole

slots and align with the gasket; tighten the two screws until snug (do not over-tighten).

4. Mount the weatherproof cover to the backing plate as shown in Fig. 30.
5. Remove two slot fillers in the bottom of the cover to permit service tool cords to exit the cover.
6. Check cover installation for full closing and latching.

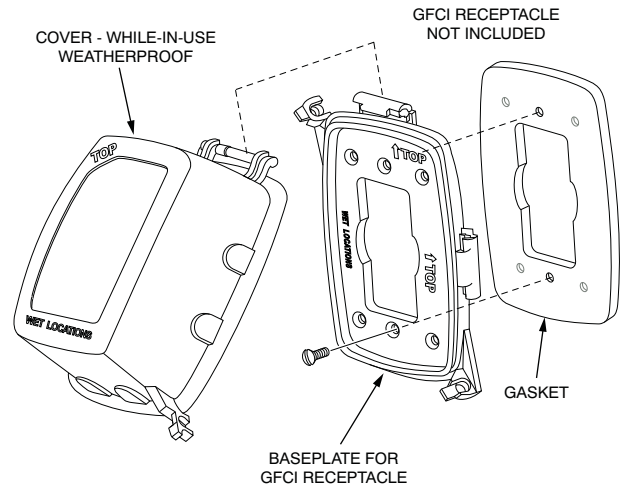

C09022

Fig. 30 – Weatherproof Cover Installation

Non-powered type — This type requires the field installation of a general-purpose 125VAC/15AC circuit powered from a source elsewhere in the building. Observe national and local codes when selecting wire size, fuse or breaker requirements and disconnect switch size and location. Route 125VAC power supply conductors into the bottom of the utility box containing the duplex receptacle.

Unit-powered type — A unit-mounted transformer is factory-installed to step-down the main power supply voltage to the unit to 115VAC at the duplex receptacle. This option also includes a manual switch with fuse, located in a utility box and mounted on a bracket behind the convenience outlet; access is through the unit's control box access panel. See Fig. 29.

The primary leads to the convenience outlet transformer are not factory-connected. Selection of primary power source is a customer-option. If local codes permit, the transformer primary leads can be connected at the line-side terminals on the unit-mounted non-fused disconnect or HACR breaker switch. This will provide service power to the unit when the unit disconnect switch or HACR switch is open. Other connection methods will result in the convenience outlet circuit being de-energized when the unit disconnect or HACR switch is open. See Fig. 31.

Duty Cycle — the unit-powered convenience outlet has a duty cycle limitation. The transformer is intended to provide power on an intermittent basis for service tools, lamps, etc; it is not intended to provide 15 amps loading for continuous duty loads (such as electric heaters for overnight use). Observe a 50% limit on circuit loading above 8 amps (i.e., limit loads exceeding 8 amps to 30 minutes of operation every hour).

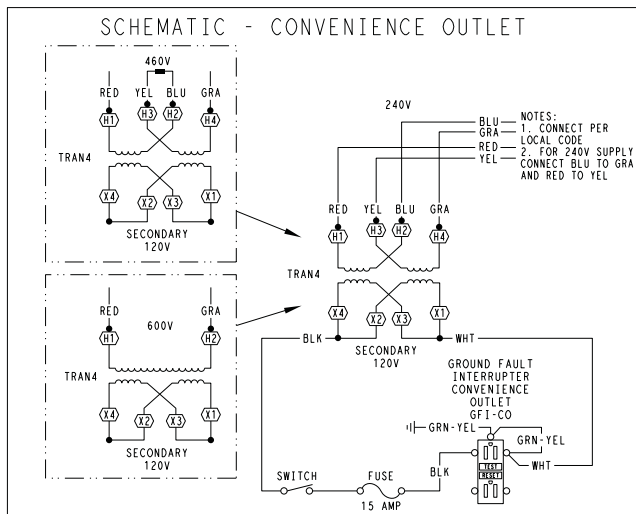

UNIT VOLTAGE	CONNECT AS	PRIMARY CONNECTIONS	TRANSFORMER TERMINALS
208, 230	240	L1: RED + YEL L2: BLU + GRA	H1 + H3 H2 + H4
460	480	L1: RED Splice BLU + YEL L2: GRA	H1 H2 + H3 H4
575	600	L1: RED L2: GRA	H1 H2

Fig. 31 – Powered Convenience Outlet Wiring

Maintenance — Periodically test the GFCI receptacle by pressing the TEST button on the face of the receptacle. This should cause the internal circuit of the receptacle to trip and open the receptacle. Check for proper grounding wires and power line phasing if the GFCI receptacle does not trip as required. Press the RESET button to clear the tripped condition.

The Fuse on the powered type — The factory fuse is a Cooper Bussmann® Fusetron® T-15, non-renewable screw-in (Edison base) type plug fuse.

Using unit-mounted convenience outlets — Units with unit-mounted convenience outlet circuits will often require two disconnects be opened to de-energize all power to the unit. Treat all units as electrically energized until the convenience outlet power is also checked and de-energization is confirmed. Observe National Electrical Code Article 210, Branch Circuits, for use of convenience outlets.

HEAT PUMP CONTROLS

Central Terminal Board

The Central Terminal Board (CTB) is a large printed circuit board that is located in the center of the unit control box. This printed circuit board contains multiple termination strips and connectors to simplify factory control box wiring and field control connections. Terminals are clearly marked on the board surface. See Fig 32.

The CTB contains no software and no logic. But it does include seven configuration jumpers that are cut to configure the board to read external optional and accessory controls, including that the unit is a heat pump.

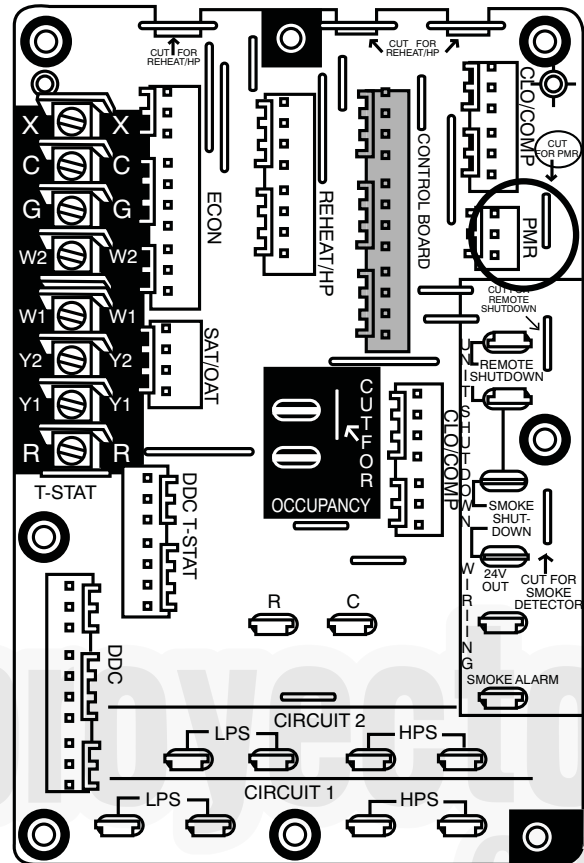

Fig. 32 – Central Terminal Board (CTB)

Table 7 – Jumper Configuration

Jumper	Control Function	Note
JMP1	Phase Monitor	
JMP2	Occupancy Control	
JMP3	Smoke Detector Shutdown	
JMP4	Remote Shutdown	
JMP5	Heat Pump / Reheat	50TCQ default: Cut
JMP6	Heat Pump / Reheat	50TCQ default: Cut
JMP7	Heat Pump / Reheat	50TCQ default: Cut

Jumpers JMP5, JMP6 and JMP7 are located in notches across the top of the CTB. See Fig. 32. These jumpers are factory cut on all heat pump units. Visually check these jumpers to confirm that they have been cut.

PROTECTIVE CONTROLS

Compressor Protection

Over-current

The compressor has internal line-break motor protection.

Over-temperature:

The compressor has an internal protector to protect it against excessively high discharge gas temperatures.

High Pressure Switch:

The system is provided with a high pressure switch mounted on the discharge line. The switch is stem-mounted and brazed into the discharge tube. Trip setting is 630 psig \pm 10 psig (4344 \pm 69 kPa) when hot. Reset is automatic at 505 psig (3482 kPa).

Loss of Charge Switch:

The system is protected against a loss of charge and low evaporator coil loading condition by a loss of charge switch located on the liquid line and a freeze protection thermostat on the indoor coil. The switch is stem-mounted. Loss of Charge Switch trip setting is 27 psig \pm 3 psig (186 \pm 21 kPa). Reset is automatic at 44 \pm 3 psig (303 \pm 21 kPa).

Freeze Protection Thermostat trip setting is 30°F \pm 5°F (-1°C \pm 3°C). Reset is automatic at 45°F \pm 5°F (7°C \pm 3°C).

Supply (Indoor) Fan Motor Protection:

Disconnect all electrical power and apply appropriate Lock-out/Tagout procedures when servicing the fan motor.

Motors are equipped with an over-temperature device (Thermik), internal line break, external circuit breaker or electronic controlled circuits for overload protection. All protection schemes are automatically reset except for units having the 2-speed indoor fan option (VFD) or external circuit breakers. These two protection schemes are classified as manual reset. The type of device depends on several factors including motor size, voltage and other options in the unit (i.e. VFD).

The Thermik device is a snap-action over-temperature protection device that is imbedded in the motor windings. It is also a pilot-circuit device that is wired into the unit's 24V control circuit. When this device reaches its trip set point, it opens the 24V control circuit and causes all unit operation to stop. This device resets automatically when the motor windings cool. Do not bypass this device to correct trouble. Determine the cause of the problem and correct it.

The External motor overload device is a specially-calibrated circuit breaker that is UL recognized as a motor overload controller. It is an over-current device. When the motor current exceeds the circuit breaker set point, the device opens all motor power leads and the motor shuts down. Reset requires a manual reset at the overload switch. This device (designated IFCB) is located on the side of the supply fan housing, behind the fan access panel.

Troubleshooting supply fan motor overload trips —

The supply fan used in the 50TCQ units is a forward-curved centrifugal wheel. At a constant wheel

speed, this wheel has a characteristic that causes the fan shaft load to DECREASE when the static pressure in the unit-duct system increases and to INCREASE when the static pressure in the unit-duct system decreases (and fan airflow rate increases). Motor overload conditions typically develop when the unit is operated with an access panel removed, with unfinished duct work, in an economizer-open mode, or a leak develops in the duct system that allows a bypass back to unit return opening.

Outdoor Fan Motor Protection:

The outdoor fan motor is internally protected against over-temperature.

Control Circuit, 24V

The control circuit is protected against over-current conditions by a circuit breaker mounted on control transformer TRAN. The Control Circuit is reset manually.

COMMERCIAL DEFROST CONTROL

The Commercial Defrost Control Board (DFB) coordinates thermostat demands for supply fan control, 1 or 2 stage cooling, 2 stage heating, emergency heating and defrost control with unit operating sequences. The DFB also provides an indoor fan off delay feature (user selectable). See Fig. 33 for board arrangement.

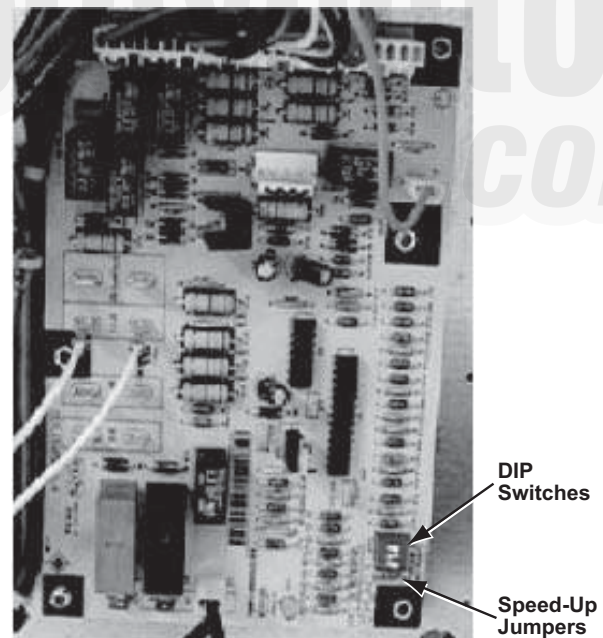

C09275

Fig. 33 – Defrost Control Board Arrangement

The DFB is located in the 50TCQ's main control box (see Fig. 34). All connections are factory-made through harnesses to the unit's CTB, to IFC (belt-drive motor) or to ECM (direct-drive motor), reversing valve solenoids and to defrost thermostats. Refer to Table 8 for details of DFB Inputs and Outputs. Detailed unit operating sequences are provided in the Start-Up section starting on page 41.

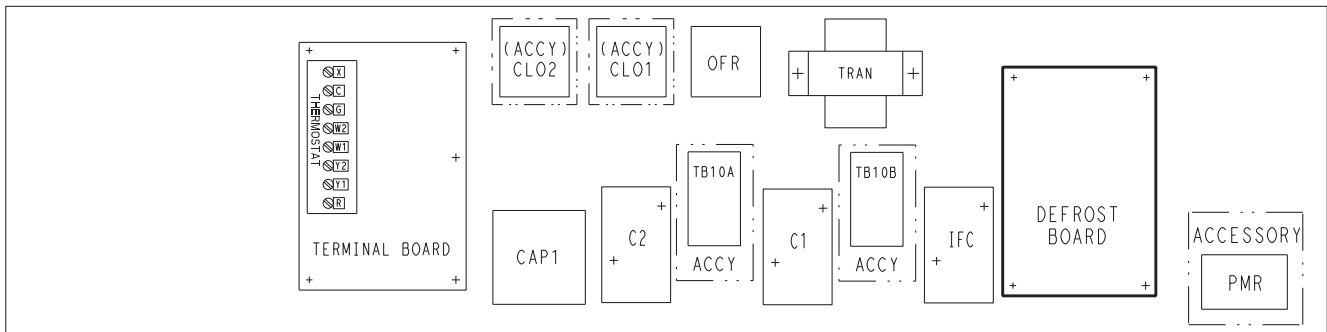

C09276

Fig. 34 – Defrost Control Board Location

Table 8 – 50TCQ Defrost Board I/O and Jumper Configurations

Inputs

Point Name	Type of I/O	Connection Pin Number	Unit Connection	Note
G Fan	DI, 24Vac	P2-3	LCTB-G	
Y1 Cool 1	DI, 24Vac	P2-5	LCTB-Y1	
Y2 Cool 2	DI, 24Vac	P2-4	LCTB-Y2	
W1 Heat 1	DI, 24Vac	P2-7	LCTB-W1	
W2 Heat 2	DI, 24Vac	P2-6	LCTB-W2	
R Power	24Vac	P3-1	CONTL BRD-8	
C Common	24Vac	P3-2	CONTL BRD-4	
DFT1	DI, 24Vac	DFT-1 to DFT-1		
DFT 2	DI, 24Vac	DFT-2 to DFT-2		

Outputs

Point Name	Type of I/O	Connection Pin Number	Unit Connection	Note
IFO Fan On	DO, 24Vac	P3-9	REHEAT-2	
OF OD Fan On	DO, 24Vac	OF	OFR	
RVS1	DO, 24Vac	P3-7 to P3-5		Energize in COOL
RVS2	DO, 24Vac	P3-6 to P3-4		Energize in COOL
COMP 1	DO, 24Vac	P3-10	FPT – REHEAT-6	
COMP 2	DO, 24Vac	P3-8	REHEAT-8	
HEAT 2	DO, 24Vac	E-HEAT	HC-1 (TB4-1)	
COM	24Vac	P3-3	HC-1 (TB4-3)	

Configuration

Point Name	Type of I/O	Connection Pin Number	Unit Connection	Note
Select Jumper	24Vac	P1-1		
2 Compressor	24Vac	P1-3		Use for 50TCQD

Speed-Up Configuration

Point Name	Type of I/O	Connection Pin Number	Unit Connection	Note
Speed-Up Jumper		JMP17		
Speed-Up Jumper		JMP18		

Jumper for 1-3 seconds: Factory Test, defrost runs for 9 seconds

Jumper for 5-20 seconds: Forced Defrost, defrost runs for 30 seconds if DFT2 is open

Reversing valve control — The DFB has two outputs for unit reversing valve control. Operation of the reversing valves is based on internal logic; this application does not use an “O” or “B” signal to determine reversing valve position. Reversing valves are energized during the cooling stages and the defrost cycle and de-energized during heating cycles. Once energized at the start of a cooling stage, the reversing valve will remain energized until the next heating cycle demand is received. Once de-energized at the start of a Heating cycle, the reversing

valves will remain de-energized until the next cooling stage is initiated.

Compressor control — The DFB receives inputs indicating Stage 1 Cooling, Stage 2 Cooling (sizes 08 – 14) and Stage 1 Heating from the space thermostat or unit control system (PremierLink® or RTU-OPEN); it generates commands to start compressors with or without reversing valve operation to produce Stage 1 Cooling (one compressor), Stage 2 Cooling (both compressors run) or

Stage 1 Heating (both compressors run on 8–14 systems. The 04–07 systems have only one compressor).

Auxiliary (Electric) Heat control — The 50TCQ unit can be equipped with one or two auxiliary electric heaters, to provide a second stage of heating. The DFB will energize this Heating System for a Stage 2 Heating Command (heaters operate concurrently with compressor(s) in the Stage 1 Heating cycle), for an Emergency Heating sequence (compressors are off and only the electric heaters are energized) and also during the Defrost cycle (to eliminate a “cold blow” condition in the space).

Defrost — The defrost control mode is a time/temperature sequence. There are two time components: The continuous run period and the test/defrost cycle period. The temperature component is provided by Defrost Thermostat 1 and 2 (DFT1 and DFT2 (A08–D09 only) mounted on the outdoor coil.

The continuous run period is a fixed time period between the end of the last defrost cycle (or start of the current Heating cycle) during which no defrost will be permitted. This period can be set at 30, 60, 90 or 120 minutes by changing the positions of DIP switches SW1 and SW2 (see Fig. 35 and Table 9). The default run periods are 60 minutes for unit sizes 04–06, 30 minutes for unit size 07, 90 minutes for unit sizes 08–09 and 60 minutes for unit sizes 12–14.

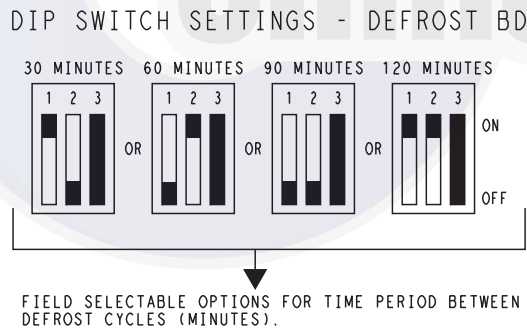

Fig. 35 – DIP Switch Settings — Defrost Board

At the end of the continuous run period, the defrost control will test for a need to defrost. On unit sizes 04–07 (single compressor designs), DFT1 controls the start and termination of the defrost cycle. If DFT1 is still open, the defrost test/run window is closed and the control repeats the continuous run period. If DFT1 is closed, the defrost cycle is initiated. The defrost period will end when DFT1 opens (indicating the outdoor coil has been cleared of frost and ice) or a 10 minute elapsed period expires, whichever comes first.

On unit sizes 08 and 14 (two circuit designs), DFT2 (located on the bottom circuit of the outdoor coil on the 08–09 size and the outdoor coil with two bends on the 12–14 sizes) controls the start and termination of the defrost cycle. If DFT2 is still open, the defrost test/run window is closed and the control repeats the continuous run period. If DFT2 is closed, the defrost cycle is initiated in Circuit 2. The defrost period will end when DFT2 opens (indicating the outdoor coil has been cleared of

frost and ice) or a 10 minute elapsed period expires, whichever comes first.

On sizes 08–14, Circuit 1’s defrost thermostat DFT1 (located on the upper circuit of the outdoor coil on 08–09 size and the outdoor coil with one bend on the 12–14 sizes.) cannot initiate a unit defrost cycle; only DFT2 can do this. But once Circuit 2 is in defrost, the DFB will monitor the status of DFT1. If DFT1 closes during a Circuit 2 defrost cycle, Circuit 1 will also enter a defrost cycle. Circuit 1’s defrost cycle will end when DFT1 opens (indicating the upper portion of the outdoor coil is cleared of frost and ice) or the Circuit 2 defrost cycle is terminated.

At the end of the unit defrost cycle, the unit will be returned to Heating cycle for a full continuous run period.

If the space heating load is satisfied and compressor operation is terminated, the defrost control will remember where the run period was interrupted. On restart in Heating, the defrost control will resume unit operation at the point in the run period where it was last operating.

Defrost Thermostats — These are temperature switches that monitor the surface temperature of the outdoor coil circuits. These switches are mounted on the liquid tube exiting the outdoor coil heating circuits. These switches close on temperature drop at 30°F (–1°C) and reset open on temperature rise at 80°F (27°C).

Indoor Fan Off Delay — The DFB can provide a 60 sec delay on Indoor Fan Off if the thermostat’s fan selector switch is set on AUTO control. DIP Switch SW3 on the DFB selects use of the fan off time delay feature. Setting SW3 in the OPEN position turns the Fan Off Delay feature on; setting SW3 in the CLOSED position disables this feature. The delay period begins when Y1 demand or W1 demand by the space thermostat is removed.

Defrost Speedup Functions — The DFB permits the servicer to speed-up the defrost cycle. There are two speed-up sequences: relative speed-up and an immediate forced defrost. Speed-up sequences are initiated by shorting jumper wires JMP17 and JMP18 together (see Fig. 33); use a flat-blade screwdriver.

Shorting the jumpers for a period of 1 to 3 seconds reduces the defrost timer periods by a factor of 0.1 sec/minute. (For example, the 90 minute run period is reduced to 9 seconds) The DFB will step the unit through a Heating cycle and a Defrost cycle using these reduced time periods. This mode ends after the Defrost cycle.

Table 9 – Dip Switch Position

Switch No.		1	2	1	2	1	2	1	2	1	2	3		
1				1	■	1	■	1	■	1	■	1	On	
0	■	■	0	■		0		0	■	0		0	■	Off
90 minutes			60 minutes			30 minutes			120 minutes			Fan Delay		

Shorting the jumpers for a period of 5 to 20 secs bypasses the remaining continuous run period and places the unit in a Forced Defrost mode. If the controlling DFT is closed when this mode is initiated, the unit will complete a normal defrost period that will terminate when the controlling DFT opens or the 10 minute defrost cycle limit is reached. If the controlling DFT is open when this mode is initiated, the Defrost cycle will run for 30 secs. Both modes end at the end of the Defrost cycle.

ELECTRIC HEATERS

50TCQ units can be equipped with field-installed accessory electric heaters. The heaters are modular in design, with heater frames holding open coil resistance wires strung through ceramic insulators, line-break limit switches and a control contactor. One or two heater modules can be used in a unit.

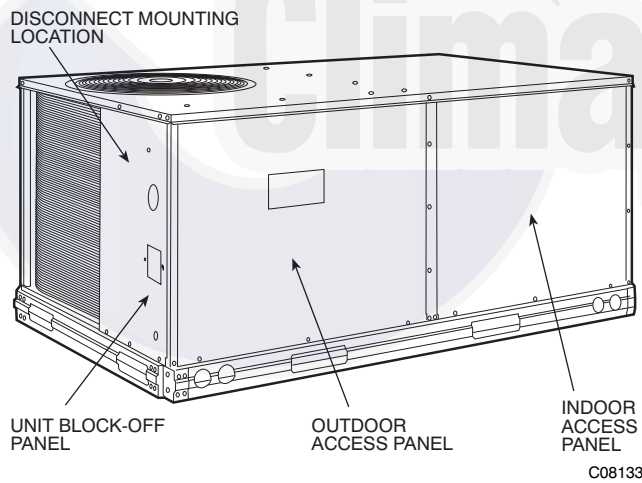

Fig. 36 – Typical Access Panel Location (3–6 Ton)

Heater modules are installed in the compartment below the indoor (supply) fan outlet. Access is through the indoor access panel. Heater modules slide into the compartment on tracks along the bottom of the heater opening. See Fig. 36, Fig. 37 and Fig. 38.

Not all available heater modules can be used in every unit. Use only those heater modules that are UL listed for use in a specific size unit. Refer to the label on the unit cabinet re approved heaters.

Unit heaters are marked with Heater Model Numbers. However, heaters are ordered as and shipped in cartons marked with a corresponding heater Sales Package part number. See Table 10 for correlation between heater Model Number and Sales Package part number.

NOTE: The value in position 9 of the part number differs between the sales package part number (value is 1) and a bare heater model number (value is 0).

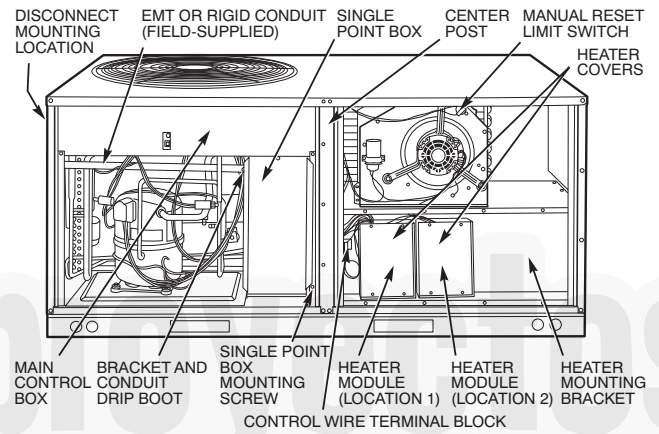

Fig. 37 – Typical Component Location

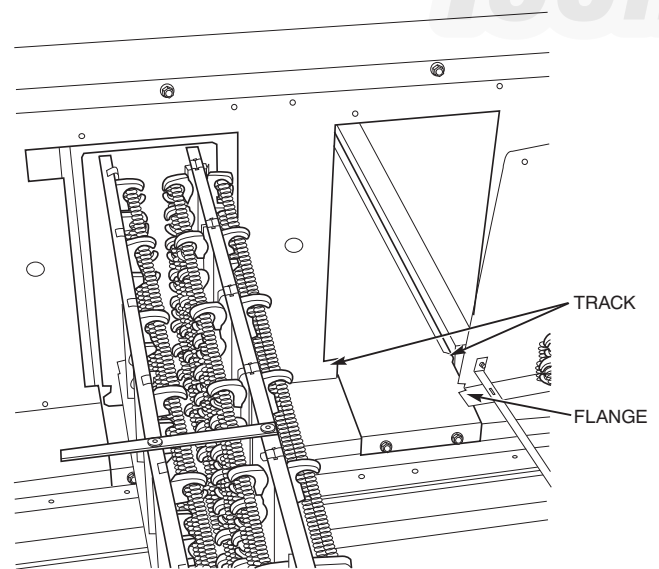
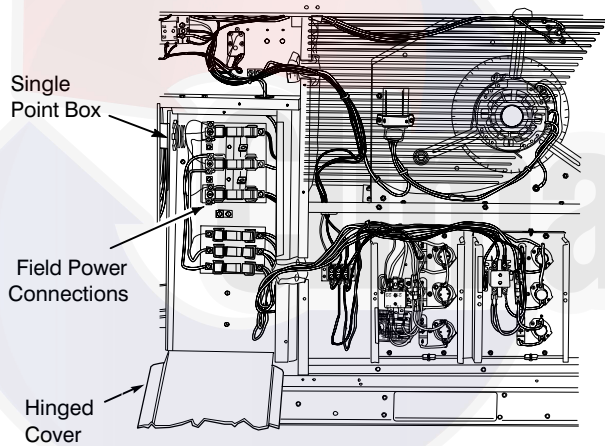

Fig. 38 – Typical Module Installation

Table 10 – Heater Model Number

Bare Heater Model Number	C	R	H	E	A	T	E	R	0	0	1	A	0	0
Heater Sales Package PNO Includes: Bare Heater Carton and packing materials Installation sheet	C	R	H	E	A	T	E	R	1	0	1	A	0	0

Single Point Boxes and Supplementary Fuses — When the unit MOCP device value exceeds 60A, unit-mounted supplementary fuses are required for each heater circuit. These fuses are included in accessory Single Point Boxes, with power distribution and fuse blocks. The single point box will be installed directly under the unit control box, just to the left of the partition separating the indoor section (with electric heaters) from the outdoor section. The Single Point Box has a hinged access cover. See Fig. 39.



C11490

Fig. 39 – Typical Single Point Installation

On 50TCQ units, all fuses are 60A. Single point boxes containing fuses for 208/230V applications use UL Class RK5 250V fuses (Bussmann FRNR 60 or Shawmut TR 60R). Single point boxes for 460V and 575V applications use UL Class T 600V fuses (Bussmann JJS 60 or Shawmut A6T 60). (Note that all heaters are qualified for use with a 60A fuse, regardless of actual heater ampacity, so only 60A fuses are necessary.)

On 07 – 14 size units, unit heater applications not requiring supplemental fuses require a special Single Point Box without any fuses. Connect power supply conductors to heater conductors and field-supplied base unit power tap leads (see text below re: “Completing Heater Installation”) inside the empty Single Point Box using UL-approved connectors.

Safety Devices — Electric heater applications use a combination of line-break/auto-reset limit switches and a

pilot-circuit/manual reset limit switch to protect the unit against over-temperature situations.

Line-break/auto-reset limit switches are mounted on the base plate of each heater module. See Fig. 40. These are accessed through the indoor access panel. Remove the switch by removing two screws into the base plate and extracting the existing switch.

Pilot-circuit/manual reset limit switch is located in the side plate of the indoor (supply) fan housing. See Fig. 37 and Fig 40.

Completing Heater Installation

Field Power Connections — Tap conductors must be installed between the base unit’s field power connection lugs and the Single Point Box (with or without fuses). See Fig. 39. Refer to unit wiring schematic. Use copper wire only. For connection using the single point box without fuses, connect the field power supply conductors to the heater power leads and the field-supplied tap conductors inside the Single Point Box. Use UL approved pressure connectors (field-supplied) for these splice joints.

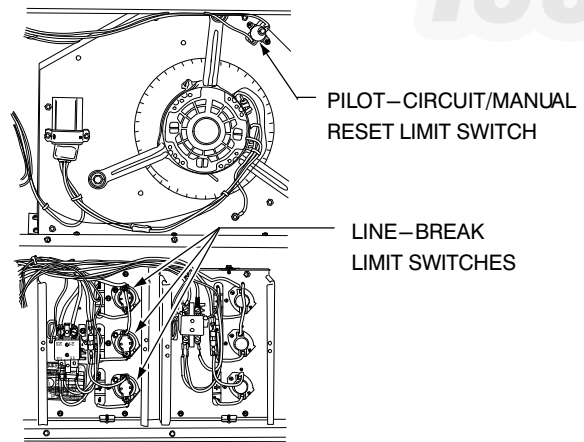

C11489

Fig. 40 – Typical Location of Heater Limit Switches (3-phase heater shown)

Low-Voltage Control Connections — Pull the low-voltage control leads from the heater module(s). The 50TCQ units use a various number of control wires, colors and terminal boards depending on voltage and unit size.

See Fig. 41 through Fig. 44 and the unit wiring diagram for proper placement.

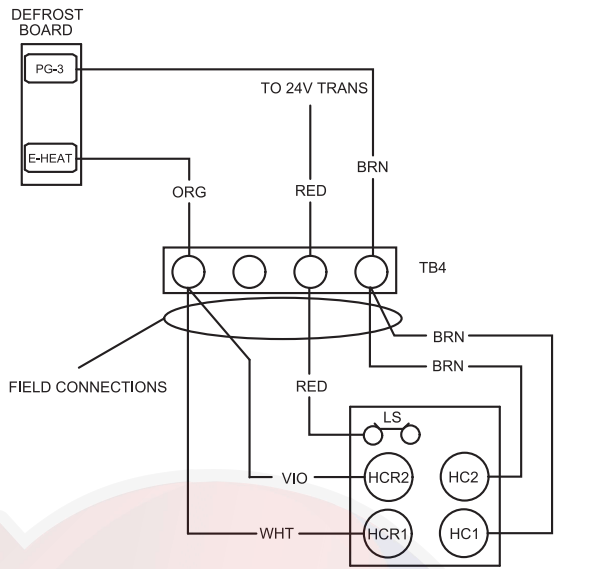
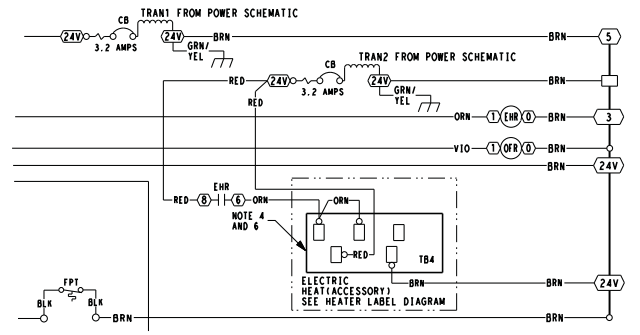

Fig. 41 – Accessory Electric Heater Control Connections (HP-2, Size 06, 575V Only)

C11554



C10561

Fig. 43 – TB4 Wiring (HP Only)

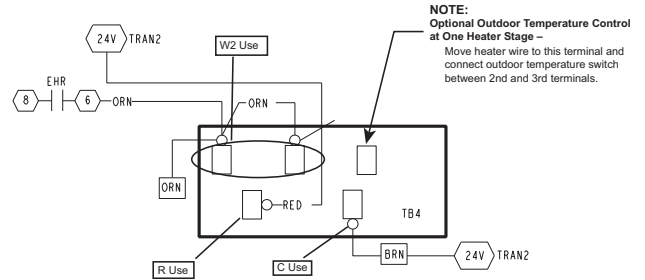

C10604

Fig. 44 – TB4 Terminal Use (HP Only)

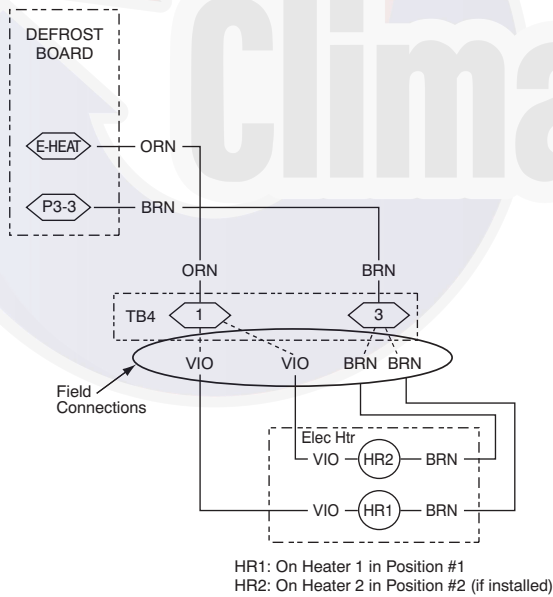

HR1: On Heater 1 in Position #1
HR2: On Heater 2 in Position #2 (if installed)

C09013

Fig. 42 – Accessory Electric Heater Control Connections (HP-1 Except Size 12 and 121, HP-2 Except Size 12)

SMOKE DETECTORS

Smoke detectors are available as factory-installed options (FIOP) on 50TCQ models. Smoke detectors can be specified for Supply Air only or for Return Air with or without economizer or in combination of Supply Air and Return Air. Return Air smoke detectors are arranged for vertical return configurations only. All components necessary for operation are factory-provided and mounted. The unit is factory-configured for immediate smoke detector shutdown operation; additional wiring or modifications to unit terminal board can be necessary to complete the unit and smoke detector configuration to meet project requirements.

System

The smoke detector system consists of a four-wire controller and one or two sensors. Its primary function is to shut down the rooftop unit in order to prevent smoke from circulating throughout the building. It is not to be used as a life saving device.

Controller

The controller (see Fig. 45) includes a controller housing, a printed circuit board, and a clear plastic cover. The controller can be connected to one or two compatible duct smoke sensors. The clear plastic cover is secured to the housing with a single captive screw for easy access to the wiring terminals. The controller has three LEDs (for Power, Trouble and Alarm) and a manual test/reset button (on the cover face).

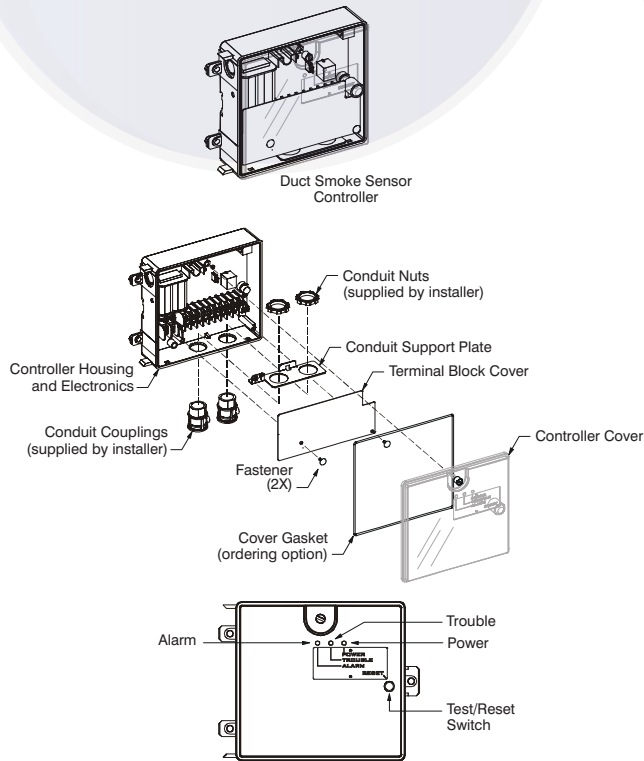

Fig. 45 – Controller Assembly

C08208A

Sensor

The sensor (see Fig. 46) includes a plastic housing, a printed circuit board, a clear plastic cover, a sampling tube inlet and an exhaust tube. The sampling tube (when used) and exhaust tube are attached during installation. The sampling tube varies in length depending on the size of the rooftop unit. The clear plastic cover permits visual inspections without having to disassemble the sensor. The cover attaches to the sensor housing using four captive screws and forms an airtight chamber around the sensing electronics. Each sensor includes a harness with an RJ45 terminal for connecting to the controller. Each sensor has four LEDs (for Power, Trouble, Alarm and Dirty) and a manual test/reset button (on the left-side of the housing).

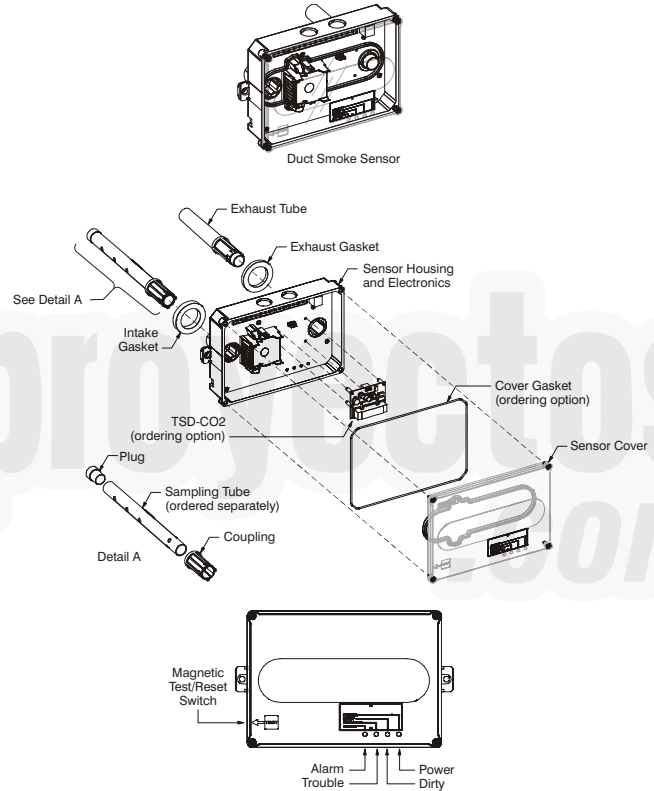

Fig. 46 – Smoke Detector Sensor

C08209A

Air is introduced to the duct smoke detector sensor's sensing chamber through a sampling tube that extends into the HVAC duct and is directed back into the ventilation system through a (shorter) exhaust tube. The difference in air pressure between the two tubes pulls the sampled air through the sensing chamber. When a sufficient amount of smoke is detected in the sensing chamber, the sensor signals an alarm state and the controller automatically takes the appropriate action to shut down fans and blowers, change over air handling systems, notify the fire alarm control panel, etc.

The sensor uses a process called *Differential Sensing* to prevent gradual environmental changes from triggering false alarms. A rapid change in environmental conditions, such as smoke from a fire, causes the sensor to signal an alarm state but dust and debris accumulated over time does not.

For installations using two sensors, the duct smoke detector does not differentiate which sensor signals an alarm or trouble condition.

Smoke Detector Locations

Supply Air — The Supply Air smoke detector sensor is located to the left of the unit's indoor (supply) fan. See Fig. 47. Access is through the fan access panel. There is no sampling tube used at this location. The sampling tube inlet extends through the side plate of the fan housing (into a high pressure area). The controller is located on a bracket to the right of the return filter, accessed through the lift-off filter panel.

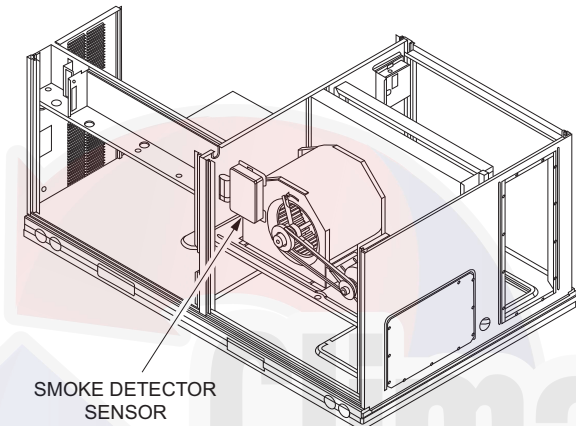

C08245

Fig. 47 – Typical Supply Air Smoke Detector Sensor Location

Return Air with Economizer — The sampling tube is inserted through the side plates of the economizer housing, placing it across the return air opening on the unit base pan. See Fig. 49. The holes in the sampling tube face downward, into the return air stream. The sampling tube is connected via tubing to the return air sensor that is mounted on a bracket high on the partition between return filter and controller location. (This sensor is shipped in a flat-mounting location. Installation requires that this sensor be relocated to its operating location and the tubing to the sampling tube be connected. See “Completing Installation of Return Air Smoke Sensor” for installation steps.)

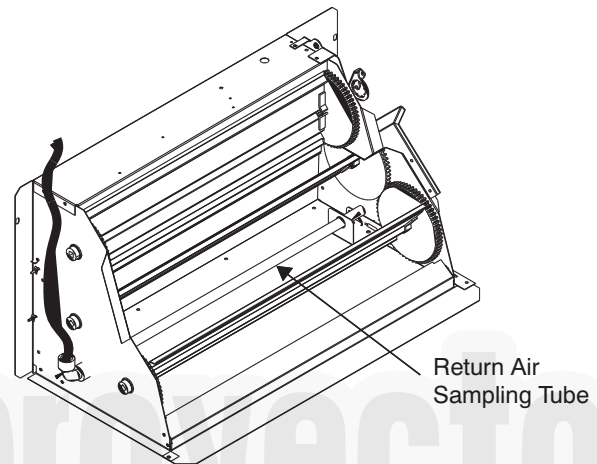

C08129

Fig. 49 – Return Air Sampling Tube Location

Return Air without Economizer — The sampling tube is located across the return air opening on the unit base pan. See Fig. 48. The holes in the sampling tube face downward, into the return air stream. The sampling tube is connected by tubing to the return air sensor that is mounted on a bracket high on the partition between return filter and controller location. (This sensor is shipped in a flat-mounting location. Installation requires that this sensor be relocated to its operating location and the tubing to the sampling tube be connected. See “Completing Installation of Return Air Smoke Sensor” for installation steps.)

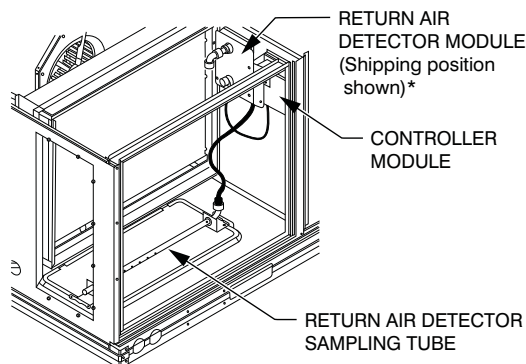

*RA detector must be moved from shipping position to operating position by installer

C07307

Fig. 48 – Typical Return Air Detector Location

Completing Installation of Return Air Smoke Sensor

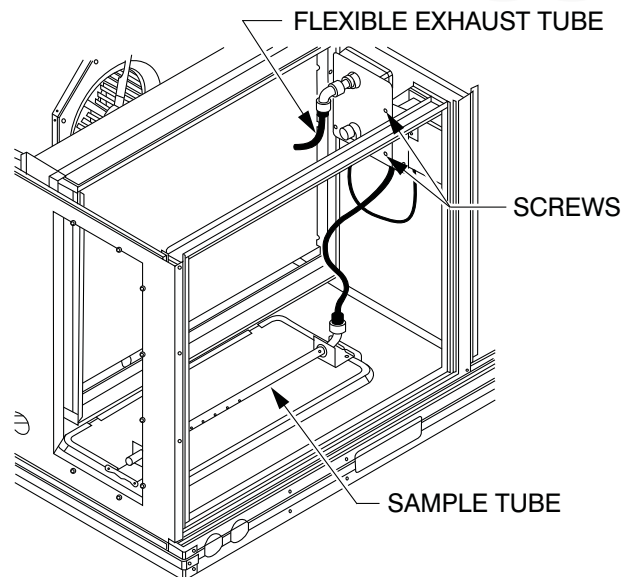

C12049

Fig. 50 – Return Air Detector Shipping Position

1. Unscrew the two screws holding the Return Air Sensor detector plate. See Fig. 50. Save the screws.
2. Remove the Return Air Sensor and its detector plate.

3. Rotate the detector plate so the sensor is facing outwards and the sampling tube connection is on the bottom. See Fig. 51.
4. Screw the sensor and detector plate into its operating position using screws from Step 1. Make sure the sampling tube connection is on the bottom and the exhaust tube is on the top. See Fig. 51.
5. Connect the flexible tube on the sampling inlet to the sampling tube on the base pan.
6. For units with an economizer, the sampling tube is integrated into the economizer housing but the connection of the flexible tubing to the sampling tube is the same.

FIOP Smoke Detector Wiring and Response

All units: FIOP smoke detector is configured to automatically shut down all unit operations when smoke condition is detected. See Fig. 52, Typical Smoke Detector System Wiring.

Highlight A: JMP 3 is factory-cut, transferring unit control to smoke detector.

Highlight B: Smoke detector NC contact set will open on smoke alarm condition, de-energizing the ORN conductor.

Highlight C: 24V power signal via ORN lead is removed at Smoke Detector input on CTB (Control Terminal Board); all unit operations cease immediately.

PremierLink Control: Unit operating functions (fan, cooling and heating) are terminated as described above. In addition:

Highlight D: On smoke alarm condition, the smoke detector NO Alarm contact will close, supplying 24V power to GRA conductor.

Highlight E: GRA lead at Smoke Alarm input on CTB provides 24V signal to FIOP DDC control.

PremierLink: This signal is conveyed to PremierLink FIOPs TB1 at terminal TB1-6 (BLU lead). This signal initiates the FSD sequence by the PremierLink control. FSD status is reported to connected CCN network.

RTU-OPEN: The 24V signal is conveyed to RTU-OPEN's J1-10 input terminal. This signal initiates the FSD sequence by the RTU-OPEN control. FSD status is reported to connected BAS network.

Using Remote Logic: Five conductors are provided for field use (see Highlight F in Fig. 52) for additional annunciation functions.

Additional Application Data — Refer to Catalog No. HKRNKA-1XA for discussions on additional control features of these smoke detectors including multiple unit coordination. See Fig. 52.

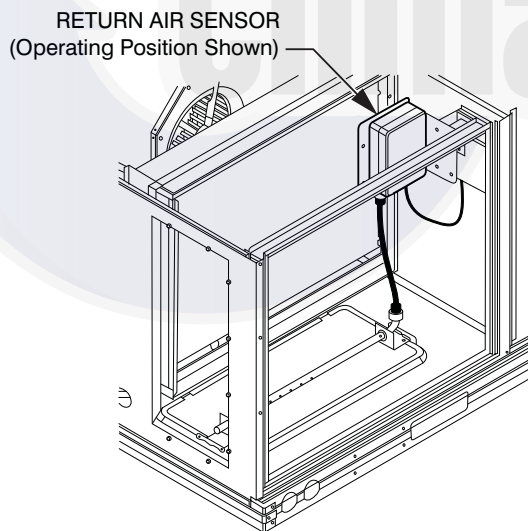

C12050

Fig. 51 – Return Air Sensor Operating Position

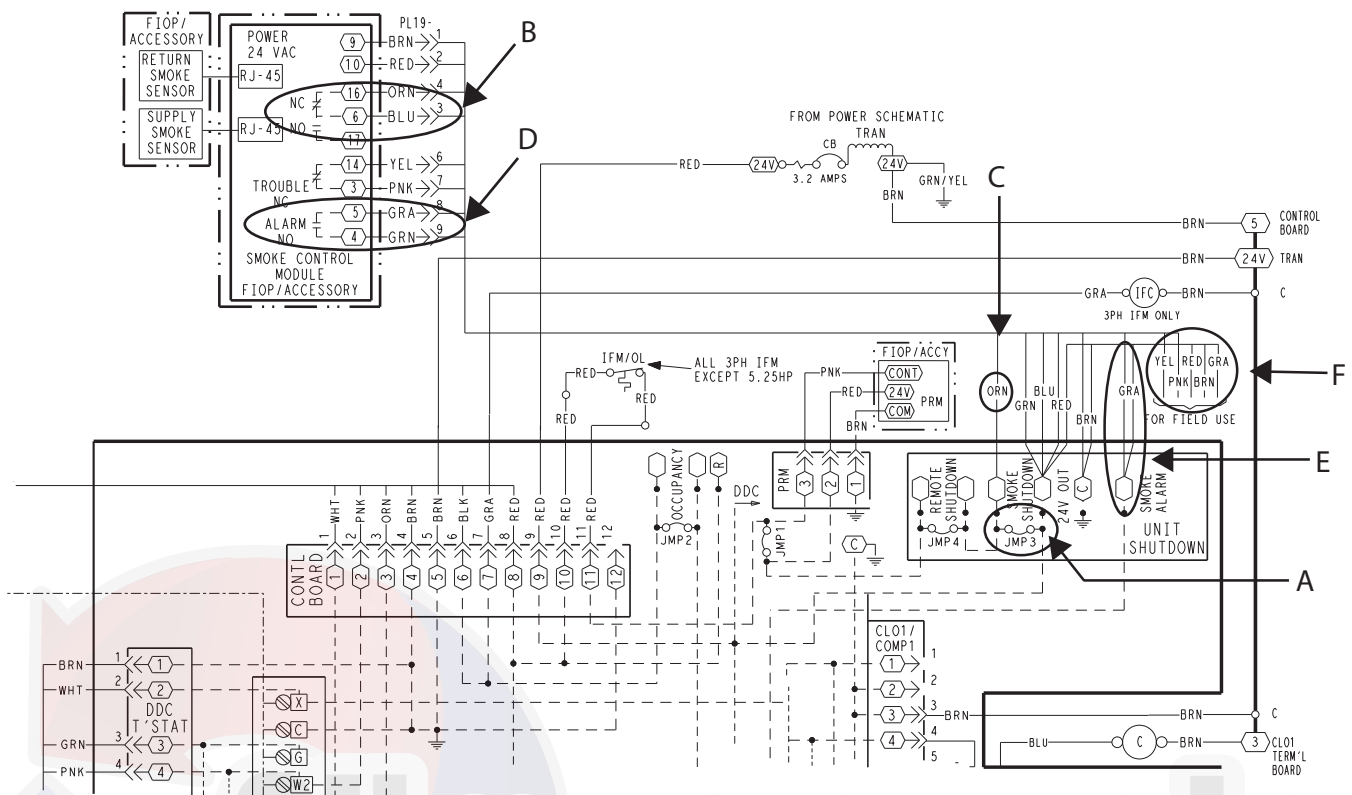

Fig. 52 – Typical Smoke Detector System Wiring

C08246

Sensor and Controller Tests

Sensor Alarm Test

The sensor alarm test checks a sensor's ability to signal an alarm state. This test requires that you use a field provided SD-MAG test magnet.

NOTICE

OPERATIONAL TEST ALERT

Failure to follow this ALERT can result in an unnecessary evacuation of the facility.

This test places the duct detector into the alarm state. Unless part of the test, disconnect all auxiliary equipment from the controller before performing the test. If the duct detector is connected to a fire alarm system, notify the proper authorities before performing the test.

Sensor Alarm Test Procedure

1. Hold the test magnet where indicated on the side of the sensor housing for seven seconds.
2. Verify that the sensor's Alarm Light Emitting Diode (LED) turns on.
3. Reset the sensor by holding the test magnet against the sensor housing for two seconds.
4. Verify that the sensor's Alarm LED turns off.

Controller Alarm Test

The controller alarm test checks the controller's ability to initiate and indicate an alarm state.

NOTICE

OPERATIONAL TEST ALERT

Failure to follow this ALERT can result in an unnecessary evacuation of the facility.

This test places the duct detector into the alarm state. Unless part of the test, disconnect all auxiliary equipment from the controller before performing the test. If the duct detector is connected to a fire alarm system, notify the proper authorities before performing the test.

Controller Alarm Test Procedure

1. Press the controller's test/reset switch for seven seconds.
2. Verify that the controller's Alarm LED turns on.
3. Reset the sensor by pressing the test/reset switch for two seconds.
4. Verify that the controller's Alarm LED turns off.

Dirty Controller Test

The dirty controller test checks the controller's ability to initiate a dirty sensor test and indicate its results.

NOTICE

OPERATIONAL TEST ALERT

Failure to follow this ALERT can result in an unnecessary evacuation of the facility.

Pressing the controller's test/reset switch for longer than seven seconds will put the duct detector into the alarm state and activate all automatic alarm responses.

Dirty Controller Test Procedure

1. Press the controller's test/reset switch for two seconds.
2. Verify that the controller's Trouble LED flashes.

Dirty Sensor Test

The dirty sensor test provides an indication of the sensor's ability to compensate for gradual environmental changes. A sensor that can no longer compensate for environmental changes is considered 100% dirty and requires cleaning or replacing. You must use a field provided SD-MAG test magnet to initiate a sensor dirty test. The sensor's Dirty LED indicates the results of the dirty test as shown in Table 11.

NOTICE

OPERATIONAL TEST ALERT

Failure to follow this ALERT can result in an unnecessary evacuation of the facility.

Holding the test magnet against the sensor housing for more than seven seconds will put the duct detector into the alarm state and activate all automatic alarm responses.

Table 11 – Dirty LED Test

FLASHES	DESCRIPTION
1	0–25% dirty. (Typical of a newly installed detector)
2	25–50% dirty
3	51–75% dirty
4	76–99% dirty

Dirty Sensor Test Procedure:

1. Hold the test magnet where indicated on the side of the sensor housing for two seconds.
2. Verify that the sensor's Dirty LED flashes.

NOTICE

OPERATIONAL TEST ALERT

Failure to follow this ALERT can result in an unnecessary evacuation of the facility.

Changing the dirty sensor test operation will put the detector into the alarm state and activate all automatic alarm responses. Before changing dirty sensor test operation, disconnect all auxiliary equipment from the controller and notify the proper authorities if connected to a fire alarm system.

Changing the Dirty Sensor Test

By default, sensor dirty test results are indicated by:

- The sensor's Dirty LED flashing.
- The controller's Trouble LED flashing.
- The controller's supervision relay contacts toggle.

The operation of a sensor's dirty test can be changed so that the controller's supervision relay is not used to indicate test results. When two detectors are connected to a controller, sensor dirty test operation on both sensors must be configured to operate in the same manner.

Configure the Dirty Sensor Test Operation:

1. Hold the test magnet where indicated on the side of the sensor housing until the sensor's Alarm LED turns on and its Dirty LED flashes twice (approximately 60 seconds).
2. Reset the sensor by removing the test magnet then holding it against the sensor housing again until the sensor's Alarm LED turns off (approximately 2 seconds).

Remote Station Test

The remote station alarm test checks a test/reset station's ability to initiate and indicate an alarm state.

NOTICE

OPERATIONAL TEST ALERT

Failure to follow this ALERT can result in an unnecessary evacuation of the facility.

This test places the duct detector into the alarm state. Unless part of the test, disconnect all auxiliary equipment from the controller before performing the test. If the duct detector is connected to a fire alarm system, notify the proper authorities before performing the test.

NOTICE

OPERATIONAL TEST ALERT

Failure to follow this ALERT can result in an unnecessary evacuation of the facility.

Holding the test magnet to the target area for longer than seven seconds will put the detector into the alarm state and activate all automatic alarm responses.

SD-TRK4 Remote Alarm Test Procedure:

1. Turn the key switch to the RESET/TEST position for seven seconds.
2. Verify that the test/reset station's Alarm LED turns on.
3. Reset the sensor by turning the key switch to the RESET/TEST position for two seconds.
4. Verify that the test/reset station's Alarm LED turns off.

Remote Test/Reset Station Dirty Sensor Test

The test/reset station dirty sensor test checks the test/reset station's ability to initiate a sensor dirty test and indicate the results. It must be wired to the controller as shown in Fig. 53 and configured to operate the controller's supervision relay. For more information, see "Changing the Dirty Sensor Test."

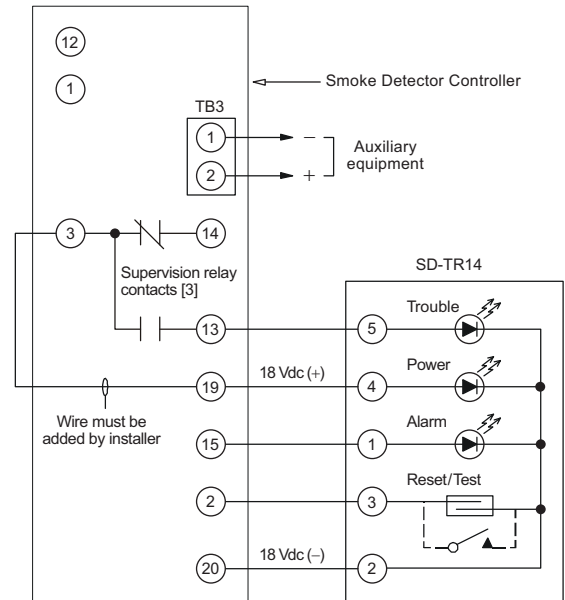

C08247

Fig. 53 – Remote Test/Reset Station Connections

NOTICE

OPERATIONAL TEST ALERT

Failure to follow this ALERT can result in an unnecessary evacuation of the facility.

Holding the test magnet to the target area for longer than seven seconds will put the detector into the alarm state and activate all automatic alarm responses.

Dirty Sensor Test Using an SD-TRK4 Test Set:

1. Turn the key switch to the RESET/TEST position for two seconds.
2. Verify that the test/reset station's Trouble LED flashes.

Table 12 – Detector Indicators

CONTROL OR INDICATOR	DESCRIPTION
Magnetic test/reset switch	Resets the sensor when it is in the alarm or trouble state. Activates or tests the sensor when it is in the normal state.
Alarm LED	Indicates the sensor is in the alarm state.
Trouble LED	Indicates the sensor is in the trouble state.
Dirty LED	Indicates the amount of environmental compensation used by the sensor (flashing continuously = 100%)
Power LED	Indicates the sensor is energized.

Detector Cleaning

Cleaning the Smoke Detector:

Clean the duct smoke sensor when the Dirty LED is flashing continuously or sooner if conditions warrant.

NOTICE

OPERATIONAL TEST ALERT

Failure to follow this ALERT can result in an unnecessary evacuation of the facility.

If the smoke detector is connected to a fire alarm system, first notify the proper authorities that the detector is undergoing maintenance then disable the relevant circuit to avoid generating a false alarm.

1. Disconnect power from the duct detector then remove the sensor's cover. See Fig. 54.
2. Using a vacuum cleaner, clean compressed air, or a soft bristle brush, remove loose dirt and debris from inside the sensor housing and cover. Use isopropyl alcohol and a lint-free cloth to remove dirt and other contaminants from the gasket on the sensor's cover.
3. Squeeze the retainer clips on both sides of the optic housing then lift the housing away from the printed circuit board.
4. Gently remove dirt and debris from around the optic plate and inside the optic housing.
5. Replace the optic housing and sensor cover.
6. Connect power to the duct detector then perform a sensor alarm test.

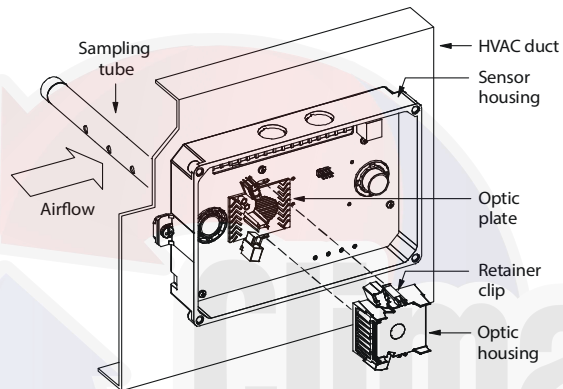

Fig. 54 – Sensor Cleaning Diagram

C07305

Indicators

Normal State:

The smoke detector operates in the normal state in the absence of any trouble conditions and when its sensing chamber is free of smoke. In the normal state, the Power LED on both the sensor and the controller are on and all other LEDs are off.

Alarm State:

The smoke detector enters the alarm state when the amount of smoke particulate in the sensor's sensing chamber exceeds the alarm threshold value. See Table 12. Upon entering the alarm state:

- The sensor's Alarm LED and the controller's Alarm LED turn on.
- The contacts on the controller's two auxiliary relays switch positions.
- The contacts on the controller's alarm initiation relay close.
- The controller's remote alarm LED output is activated (turned on).
- The controller's high impedance multiple fan shutdown control line is pulled to ground Trouble state.

The SuperDuct duct smoke detector enters the trouble state under the following conditions:

- A sensor's cover is removed and 20 minutes pass before it is properly secured.
- A sensor's environmental compensation limit is reached

(100% dirty).

- A wiring fault between a sensor and the controller is detected.

An internal sensor fault is detected upon entering the trouble state:

- The contacts on the controller's supervisory relay switch positions. See Fig. 55.
- If a sensor trouble, the sensor's Trouble LED and the controller's Trouble LED turn on.
- If 100% dirty, the sensor's Dirty LED turns on and the controller's Trouble LED flashes continuously.
- If a wiring fault between a sensor and the controller, the controller's Trouble LED turns on but not the sensor's.

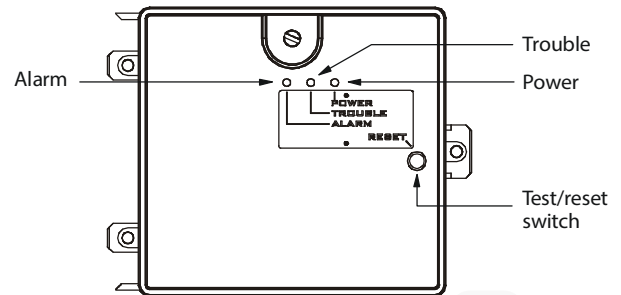

C07298

Fig. 55 – Controller Assembly

NOTE: All troubles are latched by the duct smoke detector. The trouble condition must be cleared and then the duct smoke detector must be reset in order to restore it to the normal state.

Resetting Alarm and Trouble Condition Trips

Manual reset is required to restore smoke detector systems to Normal operation. For installations using two sensors, the duct smoke detector does not differentiate which sensor signals an alarm or trouble condition. Check each sensor for Alarm or Trouble status (indicated by LED). Clear the condition that has generated the trip at this sensor. Then reset the sensor by pressing and holding the reset button (on the side) for 2 seconds. Verify that the sensor's Alarm and Trouble LEDs are now off. At the controller, clear its Alarm or Trouble state by pressing and holding the manual reset button (on the front cover) for 2 seconds. Verify that the controller's Alarm and Trouble LEDs are now off. Replace all panels.

Troubleshooting

Controller's Trouble LED is On:

1. Check the Trouble LED on each sensor connected to the controller. If a sensor's Trouble LED is on, determine the cause and make the necessary repairs.
2. Check the wiring between the sensor and the controller. If wiring is loose or missing, repair or replace as required.

Controller's Trouble LED is Flashing:

1. One or both of the sensors is 100% dirty.
2. Determine which Dirty LED is flashing then clean that sensor assembly as described in the detector cleaning section.

Sensor's Trouble LED is On:

1. Check the sensor's Dirty LED. If it is flashing, the sensor is dirty and must be cleaned.
2. Check the sensor's cover. If it is loose or missing, secure the cover to the sensor housing.
3. Replace sensor assembly.

Sensor's Power LED is Off:

1. Check the controller's Power LED. If it is off, determine why the controller does not have power and make the necessary repairs.
2. Check the wiring between the sensor and the controller. If wiring is loose or missing, repair or replace as required.

Controller's Power LED is Off:

1. Ensure the circuit supplying power to the controller is operational. If not, make sure JP2 and JP3 are set correctly on the controller before applying power.
2. Verify that power is applied to the controller's supply input terminals. If power is not present, replace or repair wiring as required.

Remote Test/Reset Station's Trouble LED Does Not flash When Performing a Dirty Test, But the Controller's Trouble LED Does:

1. Verify that the remote test/station is wired as shown in Fig. 53. Repair or replace loose or missing wiring.
2. Configure the sensor dirty test to activate the controller's supervision relay. See "To Configure the Dirty Sensor Test Operation" for details.

Sensor's Trouble LED is On, But the Controller's Trouble LED is OFF:

Remove JP1 on the controller.

Supply Air Temperature (SAT) Sensor — On FIOP-equipped 50TCQ unit, the unit is supplied with a supply-air temperature (SAT) sensor (p/n:33ZCSENSAT). This sensor is a tubular probe type, approx 6-inches (12.7 mm) in length. It is a nominal 10-k ohm thermistor. See *PremierLink™ Installation, Start-Up and Configuration Instructions*. for temperature-resistance characteristic.

PREMIERLINK™ CONTROL

The PremierLink controller (see Fig. 56) is compatible with Carrier Comfort Network® (CCN) devices. This control is designed to allow users the access and ability to change factory-defined settings, thus expanding the function of the standard unit control board. CCN service access tools include System Pilot™, Touch Pilot™ and Service Tool. Standard tier display tools Navigator™ and Scrolling Marquee are not suitable for use with latest PremierLink controller (Version 2.x).

to the LVTB. Field connections are made at a 16-pole terminal block (TB1) located on the bottom shelf of the unit control box in front of the PremierLink controller. The factory-installed PremierLink control includes the supply-air temperature (SAT) sensor. The outdoor air temperature (OAT) sensor is included in the FIOP/accessory EconoMiSer 2 package.

The PremierLink control is factory-mounted in the 50TCQ unit's main control box to the left of the CTB. Factory wiring is completed through harnesses connected

Refer to Fig. 56 for PremierLink connection locations.

NOTE: Refer to *PremierLink™ Installation, Start-Up and Configuration Instructions*. Have a copy of this manual available at unit start-up.

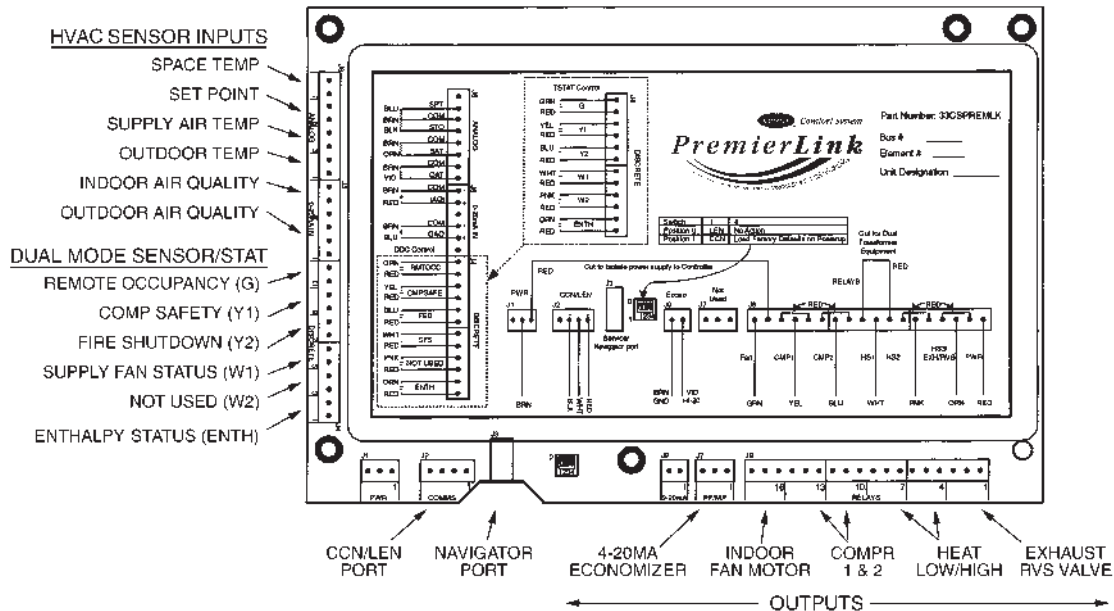

Fig. 56 – PremierLink Controller

RTU-OPEN CONTROL SYSTEM

RTU-Open Controller

The RTU-OPEN controller is an integrated component of the Carrier rooftop unit. Its internal application programming provides optimum performance and energy efficiency. RTU-OPEN enables the unit to run in 100% stand-alone control mode, Carrier's I-Vu Open network, or a Third Party Building Automation System (BAS). On-board DIP switches allow you to select your protocol (and baud rate) of choice among the four most popular protocols in use today: BACnet, Modbus, Johnson N2 and LonWorks. (See Fig. 57.)

Carrier's diagnostic display tools such as Field Assistant BACview6 Handheld or Virtual BACview can be used with the RTU-OPEN controller. Access is available via a 5-pin J12 access port.

SENSORY/ACCESSORY INSTALLATION

There are a variety of sensors and accessories available for the RTU-OPEN. Some of these can be factory or field installed, while others are only field installable. The RTU-OPEN controller can also require connection to a building network system or building zoning system. All field control wiring that connects to the RTU-OPEN must be routed through the raceway built into the corner post of the unit or secured to the unit control box with electrical conduit. The unit raceway provides the UL required clearance between high and low-voltage wiring. Pass the control wires through the hole provided in the corner post,

then feed the wires through the raceway to the RTU-OPEN. Connect the wires to the removable Phoenix connectors and then reconnect the connectors to the board. See Fig. 57.

IMPORTANT: Refer to the specific sensor or accessory instructions for its proper installation and for rooftop unit installation refer to base unit installation instructions and the unit's wiring diagrams.

WARNING

ELECTRICAL SHOCK HAZARD

Failure to follow this warning could result in personal injury, death and/or equipment damage.

Disconnect all electrical power to the unit and use appropriate Lock-out/Tagout procedures before wiring the RTU-OPEN controller.

ADDITIONAL RTU-OPEN INSTALLATION AND TROUBLESHOOTING

Refer to the following manuals: "*Controls, Start-up, Operation and Troubleshooting Instructions*," and "*RTU Open Installation and Start-up Guide*" for additional installation, wiring and troubleshooting information for the RTU-OPEN Controller. Have a copy of this manual available at unit start-up.

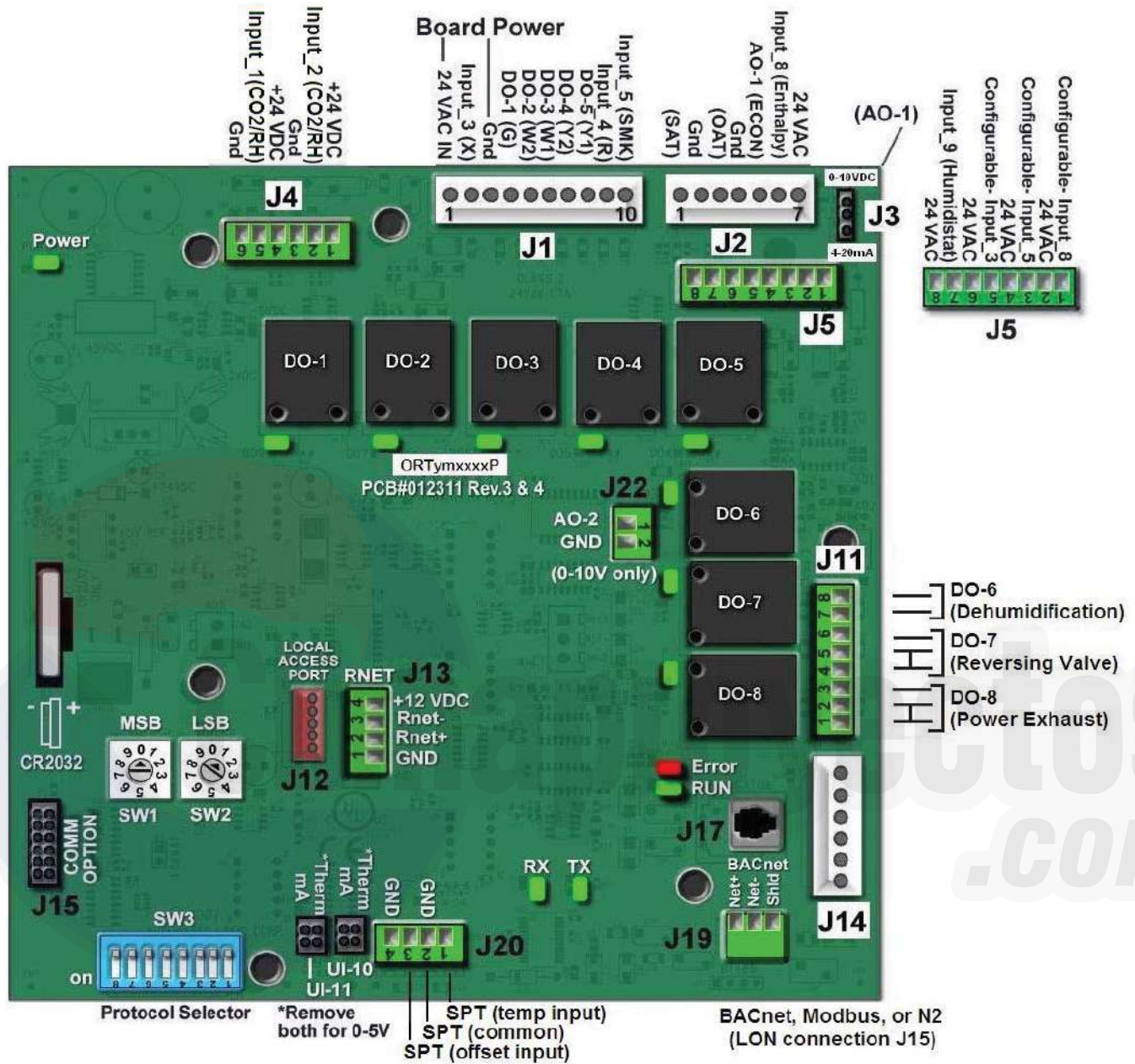

Fig. 57 – RTU-OPEN Control Module

C10818

PRE-START-UP START-UP

⚠️ WARNING

PERSONAL INJURY HAZARD

Failure to follow this warning could result in personal injury or death.

3. Follow recognized safety practices and wear approved Personal Protective Equipment (PPE), including goggles and gloves when checking or servicing refrigerant system.
4. Do not use a torch to remove any component. System contains oil and refrigerant under pressure. To remove a component, wear PPE and proceed as follows:
 - a. Shut off all electrical power to unit. Apply applicable Lock-out/Tagout procedures.
 - b. Recover refrigerant to relieve all pressure from system using both high-pressure and low pressure ports.
 - c. Do not use a torch. Cut component connection tubing with tubing cutter and remove component from unit.
 - d. Carefully un-sweat remaining tubing stubs when necessary. Oil can ignite when exposed to torch flame.
5. Do not operate compressor or provide any electric power to unit unless compressor terminal cover is in place and secured.
6. Do not remove compressor terminal cover until all electrical power is disconnected and approved Lock-out/Tagout procedures are in place.
7. Relieve all pressure from system before touching or disturbing anything inside terminal box whenever refrigerant leak is suspected around compressor terminals.
8. Never attempt to repair a soldered connection while refrigerant system is under pressure.

⚠️ WARNING

ELECTRICAL OPERATION HAZARD

Failure to follow this warning result in personal injury or death.

The unit must be electrically grounded in accordance with local codes and NEC ANSI/NFPA 70 (American National Standards Institute/National fire Protection Association).

Proceed as follows to inspect and prepare the unit for initial start-up:

1. Remove all access panels.

2. Read and follow instructions on all WARNING, CAUTION, and INFORMATION labels attached to, or shipped with, unit.

⚠️ WARNING

PERSONAL INJURY AND ENVIRONMENTAL HAZARD

Failure to follow this warning could result in personal injury or death.

Relieve pressure and recover all refrigerant before system repair or final unit disposal.

Wear safety glasses and leather gloves when handling refrigerants.

Keep torches and other ignition sources away from refrigerants and oils.

3. Perform the following inspections:
 - a. Inspect for shipping and handling damages such as broken lines, loose parts, or disconnected wires, etc.
 - b. Inspect for oil at all refrigerant tubing connections and on unit base. Detecting oil generally indicates a refrigerant leak. Leak-test all refrigerant tubing connections using electronic leak detector, halide torch, or liquid-soap solution.
 - c. Inspect all field-wiring and factory-wiring connections. Be sure that connections are completed and tight. Be sure that all electrical wires are not in contact with refrigerant tubing or sharp edges.
 - d. Inspect coil fins. If damaged during shipping and handling, carefully straighten fins with a fin comb.
4. Verify the following conditions:
 - a. Ensure that condenser-fan blades are correctly positioned in fan orifice. See Condenser-Fan Adjustment section for more details.
 - b. Ensure all air filters are in place.
 - c. Ensure that condensate drain trap is filled with water to ensuring proper drainage.
 - d. Ensure that all tools and miscellaneous loose parts have been removed.

START-UP, GENERAL

IMPORTANT: Follow the base unit's start-up sequence as described in the unit's installation instructions:

In addition to the base unit start-up, there are a few steps needed to properly start-up the controls. RTU-OPEN's Service Test function should be used to assist in the base unit start-up and also allows verification of output operation. Controller configuration is also part of start-up. This is especially important when field accessories have been added to the unit. The factory pre-configures options installed at the factory. There may also be additional installation steps or inspection required during the start-up process.

Additional Installation/Inspection

Inspect the field installed accessories for proper installation, making note of which ones do or do not require configuration changes. Inspect the RTU-OPEN's Alarms for initial insight to any potential issues. See troubleshooting section for alarms. Inspect the SAT sensor for relocation as intended during installation. Inspect special wiring as directed below.

Unit Preparation

Ensure the unit has been installed in accordance with installation instructions and applicable codes.

Return-Air Filters

Ensure the correct filters are installed in the unit (see Appendix II – Physical Data). Do not operate unit without return-air filters in place.

Outdoor-Air Inlet Screens

Outdoor-air inlet screen must be in place before operating unit.

Compressor Mounting

Compressors are internally spring mounted. Do not loosen or remove compressor hold down bolts.

Internal Wiring

Check all electrical connections in unit control boxes. Tighten as required.

Compressor Rotation

⚠ CAUTION

EQUIPMENT DAMAGE

Failure to follow this caution can result in equipment damage.

Scroll compressors can only compress refrigerant if rotating in the right direction. Reverse rotation for extended times can result in internal damage to the compressor. Scroll compressors are sealed units and cannot be repaired on site location.

On 3-phase units with scroll compressors, it is important to be certain compressor is rotating in the proper direction. To determine whether or not compressor is rotating in the proper direction:

1. Connect service gauges to suction and discharge pressure fittings.
2. Energize the compressor.
3. The suction pressure should drop and the discharge pressure should rise, as is normal on any start-up.

If the suction pressure does not drop and the discharge pressure does not rise to normal levels:

1. Note that the evaporator fan is probably also rotating in the wrong direction.

2. Turn off power to the unit and apply lockout/tagout procedures.
3. Reverse any two of the unit power leads.
4. Re-energize to the compressor. Check pressures.

The suction and discharge pressure levels should now move to their normal start-up levels.

NOTE: When the compressor is rotating in the wrong direction, the unit will make an elevated level of noise and will not provide cooling.

Refrigerant Service Ports

Each unit system has two 1/4" SAE flare (with check valves) service ports: one on the suction line, and one on the compressor discharge line. Be sure that caps on the ports are tight.

Cooling

Set space thermostat to OFF position. To start unit, turn on main power supply. Set system selector switch at COOL position and fan switch to AUTO. position. Adjust thermostat to a setting below room temperature. Compressor starts on closure of contactor. (D08-12: Second stage of thermostat will energize Circuit 2 contactor, start Compressor 2.)

Check unit charge. Refer to Refrigerant Charge section.

Reset thermostat at a position above room temperature. Compressor will shut off. Evaporator fan will shut off after a 60-second delay if the dip switch for the indoor fan off delay on the Defrost Control Board (DFB) is set to on.

To shut off unit – set system selector switch to the OFF position. Resetting thermostat at a position above room temperature shuts the unit off temporarily until space temperature exceeds thermostat setting.

Heating

To start unit, turn on main power supply.

Set system selector switch to the HEAT position and set thermostat at a setting above room temperature. Set fan to AUTO position.

First stage of thermostat energizes compressor heating (D08-12: both compressors will start). Second stage of thermostat energizes electric heaters (if installed). Check heating effects at air supply grille(s).

If electric heaters do not energize, reset limit switch (located on supply-fan scroll) by pressing button located between terminals on the switch.

Shut unit off – set system selector switch to the OFF position. Resetting thermostat at a position below room temperature temporarily shuts unit off until space temperature falls below thermostat setting.

Ventilation (Continuous Fan)

Set fan and system selector switches at ON and OFF positions, respectively. Supply fan operates continuously to provide constant air circulation.

⚠ WARNING

ELECTRICAL OPERATION HAZARD

Failure to follow this warning could result in personal injury or death.

The unit must be electrically grounded in accordance with local codes and NEC ANSI/NFPA 70 (American National Standards Institute/National Fire Protection Association.)

Use the Carrier Communication Network (CCN) software to start up and configure the PremierLink controller.

Changes can be made using the ComfortWORKS® software, ComfortVIEW™ software, Network Service Tool, System Pilot™ device, or Touch Pilot™ device. The System Pilot and Touch Pilot are portable interface devices that allow the user to change system set-up and setpoints from a zone sensor or terminal control module. During start-up, the Carrier software can also be used to verify communication with PremierLink controller.

NOTICE

SET-UP INSTRUCTIONS

All set-up and set point configurations are factory set and field-adjustable.

Refer to *PremierLink™ Installation, Start-Up and Configuration Instructions* for specific operating instructions for the controller. Have a copy of this manual available at unit start-up.

NOTICE

SET-UP INSTRUCTIONS

Refer to the following manuals for additional installation, wiring and troubleshooting information for the RTU-OPEN Controller.: *“Controls, Start-up, Operation and Troubleshooting Instructions,” “RTU Open Installation and Start-up Guide” and “RTU-Open Integration Guide”*. Have a copy of these manuals available at unit start-up.

Perform System Check-Out

1. Check all power and communication connections ensuring they are properly connected and securely tightened.
2. At the unit, check fan and system controls for proper operation.
3. At the unit, check electrical system and connections of any optional electric reheat coil.
4. Ensure all area around the unit is clear of construction dirt and debris.
5. Ensure final filters are installed in the unit. Dust and debris can adversely affect system operation.
6. Verify the PremierLink controls are properly connected to the CCN bus.



FASTENER TORQUE VALUES

Table 13 – Torque Values

Supply fan motor mounting	120 ± 12 in-lbs	13.6 ± 1.4 Nm
Supply fan motor adjustment plate	120 ± 12 in-lbs	13.6 ± 1.4 Nm
Motor pulley setscrew	72 ± 5 in-lbs	8.1 ± 0.6 Nm
Fan pulley setscrew	72 ± 5 in-lbs	8.1 ± 0.6 Nm
Blower wheel hub setscrew	72 ± 5 in-lbs	8.1 ± 0.6 Nm
Bearing locking collar setscrew	55 to 60 in-lbs	6.2 to 6.8 Nm
Compressor mounting bolts	65 to 75 in-lbs	7.3 to 7.9 Nm
Condenser fan motor mounting bolts	65 to 75 in-lbs	7.3 to 7.9 Nm
Condenser fan motor mounting bolts	20 ± 2 in-lbs	2.3 ± 0.2 Nm
Condenser fan hub setscrew	84 ± 12 in-lbs	9.5 ± 1.4 Nm

A04–06 Direct–Drive:		
Motor mount arm	60 ± 5 in-lbs	6.8 ± 0.5 Nm
Fan wheel hub setscrew	120 ± 12 in-lbs	13.6 ± 1.4 Nm
Motor belly band bolt	80 ± 5 in-lbs	9.0 ± 0.6 Nm

APPENDIX I. MODEL NUMBER SIGNIFICANCE

Model Number Nomenclature

Position:	1	2	3	4	5	6	7	8	9	10	11	12	13	14	15	16	17	18
Example:	5	0	T	C	Q	A	0	6	A	0	A	6	-	0	B	2	A	0

Series - WeatherMaker®
50TC - Packaged Rooftop

Q = Heat Pump

Refrig. Systems Options
A = One Stage Cooling Models
D = Two Stage Cooling Models

Cooling Tons
04 - 3 ton
05 - 4 ton
06 - 5 ton
07 - 6 ton
08 - 7.5 ton
09 - 8.5 ton
12 - 10 ton
14 - 12.5 ton

Sensor Options
A = None
B = RA Smoke Detector
C = SA Smoke Detector
D = RA + SA Smoke Detector
E = CO₂
F = RA Smoke Detector and CO₂
G = SA Smoke Detector and CO₂
H = RA + SA Smoke Detector and CO₂

Indoor Fan Options
0 = Electric Drive X13 Motor (04-06)
1 = Standard Static Option - Belt Drive
2 = Medium Static Option - Belt Drive
3 = High Static Option - Belt Drive
C = High Static Option with High Efficiency Motor- Belt Drive (size 14 only)

Coil Options - Round Tube/Plate Fin Condenser Coil (Outdoor - Indoor - Hail Guard)
A = Al/Cu - Al/Cu
B = Precoat Al/Cu - Al/Cu
C = E-coat Al/Cu - Al/Cu
D = E-coat Al/Cu - E-coat Al/Cu
E = Cu/Cu - Al/Cu
F = Cu/Cu - Cu/Cu
M = Al/Cu -Al/Cu — Louvered Hail Guard
N = Precoat Al/Cu - Al/Cu — Louvered Hail Guard
P = E-coat Al/Cu - Al/Cu — Louvered Hail Guard
Q = E-coat Al/Cu - E-coat Al/Cu — Louvered Hail Guard
R = Cu/Cu - Al/Cu — Louvered Hail Guard
S = Cu/Cu - Cu/Cu — Louvered Hail Guard

Note: On single phase (-3 voltage code) models, the following are not available as a factory installed option:

- Coated Coils or Cu Fin Coils
- Louvered Hail Guards
- Economizer or 2 Position Damper
- Powered 115 Volt Convenience Outlet

Factory Assigned
0 = Standard
1 = LTL
3 = CA Seismic Compliant
4 = LTL and CA Seismic Compliant

Electrical Options
A = None
C = Non-Fused Disconnect
D = Thru-The-Base Connections
F = Non-Fused Disconnect and Thru-The-Base Connections
G = 2-Speed Indoor Fan Controller (VFD)

Service Options
0 = None
1 = Unpowered Convenience Outlet
2 = Powered Convenience Outlet
3 = Hinged Access Panels
4 = Hinged Access Panels and Unpowered Convenience Outlet
5 = Hinged Panels and Powered Convenience Outlet

Intake / Exhaust Options
A = None
B = Temperature Economizer w/ Barometric Relief
F = Enthalpy Economizer w/ Barometric Relief
K = 2-Position Damper
U = Temperature Ultra Low Leak Economizer w/ Barometric Relief
W= Enthalpy Ultra Low Leak Economizer w/ Barometric Relief

Base Unit Controls
0 = Electro-mechanical Controls can be used with W7212 EconoMi\$er IV (Non-Fault Detection and Diagnostic)
1 = PremierLink Controller
2 = RTU Open Multi-Protocol Controller
6 = Electro-mechanical w/ 2-speed fan and W7220 Economizer controller Controls. Can be used with W7220 EconoMi\$er X (with Fault Detection and Diagnostic)

Design Revision
- = Factory Design Revision

Voltage
1 = 575/3/60
3 = 208-230/1/60
5 = 208-230/3/60
6 = 460/3/60

Serial Number Format

POSITION NUMBER	1	2	3	4	5	6	7	8	9	10
TYPICAL	0	4	0	9	G	1	2	3	4	5

POSITION

1-2

3-4

5

6-10

DESIGNATES

Week of manufacture (fiscal calendar)

Year of manufacture ("08" = 2008)

Manufacturing location (G = ETP, Texas, USA)

Sequential number



APPENDIX II. PHYSICAL DATA

TABLE 14 – PHYSICAL DATA
(COOLING)
3 – 6 TONS

	50TCQA04	50TCQA05	50TCQA06	50TCQA07	
Refrigeration System					
# Circuits / # Comp. / Type	1 / 1 / Scroll	1 / 1 / Scroll	1 / 1 / Scroll	1 / 1 / Scroll	
Puron® refriger. (R-410A) charge per circuit A/B (lbs-oz)	9 – 8 / –	10 – 3 / –	12 – 13 / –	17 – 10 / –	
Metering Device	Acutrol	Acutrol	Acutrol	Acutrol	
High pressure Trip / Reset (psig)	630 / 505	630 / 505	630 / 505	630 / 505	
Loss of Charge Pressure Trip / Reset (psig)	27 / 44	27 / 44	27 / 44	27 / 44	
Compressor Capacity Staging (%)	100%	100%	100%	100%	
Evap. Coil					
Material – Tube / Fin	Cu / Al	Cu / Al	Cu / Al	Cu / Al	
Coil type	3/8–in RTPF	3/8–in RTPF	3/8–in RTPF	3/8–in RTPF	
Rows / FPI	3 / 15	3 / 15	4 / 15	4 / 15	
Total Face Area (ft ²)	5.5	5.5	7.3	7.3	
Condensate Drain Conn. Size	3/4–in	3/4–in	3/4–in	3/4–in	
Evap. Fan and Motor					
Standard Static 1 phase	Motor Qty / Drive Type	1 / Direct	1 / Direct	1 / Direct	N/A
	Max BHP	1.0	1.0	1.0	N/A
	RPM Range	600–1200	600–1200	600–1200	N/A
	Motor Frame Size	48	48	48	N/A
	Fan Qty / Type	1 / Centrifugal	1 / Centrifugal	1 / Centrifugal	N/A
	Fan Diameter x Length (in)	10 x 10	10 x 10	11 x 10	N/A
Standard Static 3 phase	Motor Qty / Drive Type	1 / Direct	1 / Direct	1 / Direct	1 / Belt
	Max BHP	1.0	1.0	1.0	1.5
	RPM Range	600–1200	600–1200	600–1200	878–1192
	Motor Frame Size	48	48	48	56
	Fan Qty / Type	1 / Centrifugal	1 / Centrifugal	1 / Centrifugal	1 / Centrifugal
	Fan Diameter x Length (in)	10 x 10	10 x 10	11 x 10	10 x 10
Medium Static 3 phase	Motor Qty / Drive Type	1 / Belt	1 / Belt	1 / Belt	1 / Belt
	Max BHP	1.5	1.5	2.0	2.9
	RPM Range	819–1251	920–1303	1066–1380	1066–1380
	Motor Frame Size	56	56	56	56
	Fan Qty / Type	1 / Centrifugal	1 / Centrifugal	1 / Centrifugal	1 / Centrifugal
	Fan Diameter x Length (in)	10 x 10	10 x 10	10 x 10	10 x 10
High Static 3 phase	Motor Qty / Drive Type	1 / Belt	1 / Belt	1 / Belt	1 / Belt
	Max BHP	2.0	2.0	2.9	2.9
	RPM Range	1035–1466	1035–1466	1208–1639	1208–1639
	Motor Frame Size	56	56	56	56
	Fan Qty / Type	1 / Centrifugal	1 / Centrifugal	1 / Centrifugal	1 / Centrifugal
	Fan Diameter x Length (in)	10 x 10	10 x 10	10 x 10	10 x 10
Cond. Coil					
Material – Tube / Fin	Cu / Al	Cu / Al	Cu / Al	Cu / Al	
Coil type	3/8–in RTPF	3/8–in RTPF	3/8–in RTPF	3/8–in RTPF	
Rows / FPI	2 / 17	2 / 17	2 / 17	2 / 17	
Total Face Area (ft ²)	10.7	12.7	15	21.3	
Cond. fan / motor					
Qty / Motor Drive Type	1 / Direct	1 / Direct	1 / Direct	1 / Direct	
Motor HP / RPM	1/8 / 825	1/4 / 1100	1/4 / 1100	1/4 / 1100	
Fan diameter (in)	22	22	22	22	
Filters					
RA Filter # / Size (in)	2 / 16 x 25 x 2	2 / 16 x 25 x 2	4 / 16 x 16 x 2	4 / 16 x 16 x 2	
OA inlet screen # / Size (in)	1 / 20 x 24 x 1	1 / 20 x 24 x 1	1 / 20 x 24 x 1	1 / 20 x 24 x 1	

APPENDIX II. PHYSICAL DATA (CONT)

TABLE 15 – PHYSICAL DATA

(COOLING)

7.5 – 12.5 TONS

		50TCQD08	50TCQD09	50TCQD12	50TCQD14
Refrigeration System					
	# Circuits / # Comp. / Type	2 / 2 / Scroll	2 / 2 / Scroll	2 / 2 / Scroll	2 / 2 / Scroll
	Puron® refrig. (R-410A) charge per circuit A/B (lbs-oz)	10 – 3 / 10 – 3	11 – 2 / 11 – 2	12 – 2 / 11 – 2	14 – 8 / 13 – 8
	Metering Device	Acutrol	Acutrol	Acutrol	Acutrol
	High pressure Trip / Reset (psig)	630 / 505	630 / 505	630 / 505	630 / 505
	Loss of Charge Pressure Trip / Reset (psig)	27 / 44	27 / 44	27 / 44	27 / 44
	Compressor Capacity Staging (%)	50% / 100%	50% / 100%	50% / 100%	50% / 100%
Evap. Coil					
	Material – Tube / Fin	Cu / Al	Cu / Al	Cu / Al	Cu / Al
	Coil type	3/8-in RTPF	3/8-in RTPF	3/8-in RTPF	3/8-in RTPF
	Rows / FPI	3 / 15	4 / 15	4 / 15	3 / 15
	Total Face Area (ft ²)	11.1	11.1	11.1	17.5
	Condensate Drain Conn. Size	3/4"	3/4"	3/4"	3/4"
Evap. Fan and Motor					
Standard Static 3 phase	Motor Qty / Drive Type	1 / Belt	1 / Belt	1 / Belt	1 / Belt
	Max BHP	1.2	1.2	1.7	2.9
	RPM Range	460–652	460–652	460–652	507–676
	Motor Frame Size	56	56	56	56
	Fan Qty / Type	1 / Centrifugal	1 / Centrifugal	1 / Centrifugal	1 / Centrifugal
	Fan Diameter x Length (in)	15 x 15	15 x 15	15 x 15	18 x 18
Medium Static 3 phase	Motor Qty / Drive Type	1 / Belt	1 / Belt	1 / Belt	1 / Belt
	Max BHP	2.9	2.9	2.8	2.9
	RPM Range	591–838	591–838	591–838	634–833
	Motor Frame Size	56	56	56	56
	Fan Qty / Type	1 / Centrifugal	1 / Centrifugal	1 / Centrifugal	1 / Centrifugal
	Fan Diameter x Length (in)	15 x 15	15 x 15	15 x 15	18 x 18
High Static 3 phase	Motor Qty / Drive Type	1 / Belt	1 / Belt	1 / Belt	1 / Belt
	Max BHP	2.9	2.9	4.0	6.1
	RPM Range	838–1084	838–1084	838–1084	792–971
	Motor Frame Size	56	56	56	S184T
	Fan Qty / Type	1 / Centrifugal	1 / Centrifugal	1 / Centrifugal	1 / Centrifugal
	Fan Diameter x Length (in)	15 x 15	15 x 15	15 x 15	18 x 18
High Static \ High-Efficiency 3 phase	Motor Qty / Drive Type	N/A	N/A	N/A	1 / Belt
	Max BHP (208/230/460/575V)	N/A	N/A	N/A	6.5/6.9/7.0/8.3
	RPM Range	N/A	N/A	N/A	776–955
	Motor Frame Size	N/A	N/A	N/A	S184T
	Fan Qty / Type	N/A	N/A	N/A	1 / Centrifugal
	Fan Diameter x Length (in)	N/A	N/A	N/A	18 x 18
Cond. Coil					
	Material – Tube / Fin	Cu / Al	Cu / Al	Cu / Al	Cu / Al
	Coil type	3/8-in RTPF	3/8-in RTPF	3/8-in RTPF	3/8-in RTPF
	Rows / FPI	2 / 17	2 / 17	3 / 17	2 / 17
	Total Face Area (ft ²)	25.1	25.1	25.1	36.1
Cond. fan / motor					
	Qty / Motor Drive Type	2 / Direct	2 / Direct	1 / Direct	3 / Direct
	Motor HP / RPM	1/4 / 1100	1/4 / 1100	1 / 1175	1/4 / 1100
	Fan diameter (in)	22	22	30	22
Filters					
	RA Filter # / Size (in)	4 / 20 x 20 x 2	4 / 20 x 20 x 2	4 / 20 x 20 x 2	6 / 18 x 24 x 2
	OA inlet screen # / Size (in)	1 / 20 x 24 x 1	1 / 20 x 24 x 1	1 / 20 x 24 x 1	2 / 24 x 27 x 1 (Vertical) 1 / 30 x 39 x 1 (Horizontal)

APPENDIX III. FAN PERFORMANCE

General Fan Performance Notes:

1. Interpolation is permissible. Do not extrapolate.
2. External static pressure is the static pressure difference between the return duct and the supply duct plus the static pressure caused by any FIOPs or accessories.
3. Tabular data accounts for pressure loss due to clean filters, unit casing, and wet coils. Factory options and accessories can add static pressure losses.
4. The Fan Performance tables offer motor/drive recommendations. In cases when two motor/drive combinations would work, Carrier recommended the lower horsepower option.
5. For information on the electrical properties of Carrier's motors, please see the Electrical information section of this book.



APPENDIX III. FAN PERFORMANCE (CONT)

TABLE 16 – 50TCQA04 ELECTRIC DRIVE, X13 MOTOR, 3 TON HORIZONTAL SUPPLY

SPEED (TORQUE) TAP	CFM	ESP	BHP
1	900	0.70	0.31
	975	0.60	0.30
	1050	0.50	0.29
	1125	0.39	0.27
	1200	0.29	0.26
	1275	0.21	0.24
	1350	0.12	0.23
	1425	0.03	0.21
	1500	–	–
2	900	0.85	0.37
	975	0.76	0.36
	1050	0.66	0.36
	1125	0.55	0.34
	1200	0.46	0.34
	1275	0.36	0.32
	1350	0.27	0.31
	1425	0.17	0.29
	1500	0.07	0.27
3	900	1.02	0.44
	975	0.94	0.45
	1050	0.86	0.45
	1125	0.79	0.45
	1200	0.71	0.45
	1275	0.61	0.44
	1350	0.51	0.43
	1425	0.40	0.41
	1500	0.29	0.39
4	900	1.12	0.49
	975	1.06	0.50
	1050	1.00	0.52
	1125	0.95	0.53
	1200	0.89	0.54
	1275	0.80	0.53
	1350	0.70	0.52
	1425	0.57	0.50
	1500	0.46	0.49
5	900	1.18	0.52
	975	1.14	0.54
	1050	1.10	0.56
	1125	1.06	0.58
	1200	1.02	0.60
	1275	0.98	0.63
	1350	0.94	0.65
	1425	0.90	0.68
	1500	0.87	0.71

TABLE 17 – 50TCQA04 ELECTRIC DRIVE, X13 MOTOR, 3 TON VERTICAL SUPPLY

SPEED (TORQUE) TAP	CFM	ESP	BHP
1	900	0.44	0.22
	975	0.35	0.21
	1050	0.24	0.20
	1125	0.15	0.19
	1200	0.08	0.19
	1275	0.02	0.18
	1350	–	–
	1425	–	–
	1500	–	–
2	900	0.64	0.30
	975	0.53	0.29
	1050	0.42	0.28
	1125	0.32	0.27
	1200	0.24	0.26
	1275	0.15	0.25
	1350	0.07	0.24
	1425	–	–
	1500	–	–
3	900	0.93	0.42
	975	0.80	0.41
	1050	0.68	0.39
	1125	0.57	0.38
	1200	0.47	0.37
	1275	0.35	0.36
	1350	0.26	0.34
	1425	0.13	0.33
	1500	0.08	0.32
4	900	1.04	0.47
	975	0.92	0.46
	1050	0.80	0.45
	1125	0.71	0.45
	1200	0.62	0.45
	1275	0.52	0.44
	1350	0.43	0.44
	1425	0.27	0.42
	1500	0.22	0.41
5	900	1.10	0.50
	975	1.00	0.49
	1050	0.90	0.49
	1125	0.82	0.50
	1200	0.75	0.51
	1275	0.70	0.54
	1350	0.67	0.57
	1425	0.60	0.60
	1500	0.62	0.64

APPENDIX III. FAN PERFORMANCE (CONT)

TABLE 18 – 50TCQA05 ELECTRIC DRIVE, X13 MOTOR, 4 TON HORIZONTAL SUPPLY

SPEED (TORQUE) TAP	CFM	ESP	BHP
1	1200	0.75	0.48
	1300	0.63	0.46
	1400	0.48	0.44
	1500	0.33	0.41
	1600	0.19	0.39
	1700	0.05	0.36
	1800	–	–
	1900	–	–
	2000	–	–
2	1200	0.97	0.58
	1300	0.88	0.59
	1400	0.77	0.59
	1500	0.64	0.59
	1600	0.50	0.57
	1700	0.36	0.54
	1800	0.21	0.52
	1900	0.06	0.49
	2000	–	–
3	1200	0.98	0.59
	1300	0.91	0.60
	1400	0.82	0.62
	1500	0.71	0.62
	1600	0.58	0.61
	1700	0.45	0.60
	1800	0.31	0.58
	1900	0.16	0.56
	2000	0.03	0.52
4	1200	0.98	0.59
	1300	0.92	0.62
	1400	0.86	0.64
	1500	0.79	0.66
	1600	0.70	0.68
	1700	0.62	0.70
	1800	0.52	0.71
	1900	0.37	0.69
	2000	0.21	0.67
5	1200	1.02	0.60
	1300	0.97	0.64
	1400	0.92	0.67
	1500	0.87	0.71
	1600	0.82	0.75
	1700	0.77	0.79
	1800	0.71	0.84
	1900	0.65	0.88
	2000	0.58	0.92

TABLE 19 – 50TCQA05 ELECTRIC DRIVE, X13 MOTOR, 4 TON VERTICAL SUPPLY

SPEED (TORQUE) TAP	CFM	ESP	BHP
1	1200	0.50	0.39
	1300	0.36	0.37
	1400	0.19	0.35
	1500	0.10	0.33
	1600	0.02	0.32
	1700	–	–
	1800	–	–
	1900	–	–
	2000	–	–
	2	1200	0.80
1300		0.69	0.55
1400		0.50	0.54
1500		0.38	0.52
1600		0.24	0.50
1700		0.13	0.48
1800		0.01	0.46
1900		–	–
2000		–	–
3		1200	0.89
	1300	0.78	0.61
	1400	0.59	0.60
	1500	0.46	0.58
	1600	0.31	0.56
	1700	0.20	0.54
	1800	0.07	0.52
	1900	–	–
	2000	–	–
4	1200	0.89	0.60
	1300	0.80	0.63
	1400	0.67	0.64
	1500	0.57	0.65
	1600	0.43	0.65
	1700	0.31	0.66
	1800	0.23	0.65
	1900	0.12	0.63
	2000	0.01	0.62
5	1200	0.94	0.62
	1300	0.85	0.65
	1400	0.73	0.68
	1500	0.65	0.70
	1600	0.55	0.72
	1700	0.47	0.75
	1800	0.42	0.78
	1900	0.39	0.82
	2000	0.38	0.88

APPENDIX III. FAN PERFORMANCE (CONT)

TABLE 20 – 50TCQA06 ELECTRIC DRIVE, X13 MOTOR, 5 TON HORIZONTAL SUPPLY

SPEED (TORQUE) TAP	CFM	ESP	BHP
1	1500	1.19	0.74
	1625	1.01	0.73
	1750	0.82	0.70
	1875	0.60	0.66
	2000	0.38	0.62
	2125	0.16	0.57
	2250	–	–
	2375	–	–
	2500	–	–
2	1500	1.40	0.86
	1625	1.25	0.88
	1750	1.08	0.86
	1875	0.90	0.84
	2000	0.67	0.80
	2125	0.44	0.75
	2250	0.20	0.71
	2375	–	–
	2500	–	–
3	1500	1.41	0.87
	1625	1.28	0.89
	1750	1.13	0.89
	1875	0.96	0.88
	2000	0.74	0.85
	2125	0.51	0.80
	2250	0.27	0.75
	2375	0.02	0.70
	2500	–	–
4	1500	1.44	0.89
	1625	1.35	0.93
	1750	1.24	0.96
	1875	1.11	0.98
	2000	0.90	0.96
	2125	0.69	0.92
	2250	0.43	0.86
	2375	0.17	0.81
	2500	–	–
5	1500	1.49	0.90
	1625	1.38	0.95
	1750	1.28	1.00
	1875	1.18	1.05
	2000	1.11	1.09
	2125	0.97	1.11
	2250	0.72	1.07
	2375	0.47	1.02
	2500	0.20	0.96

TABLE 21 – 50TCQA06 ELECTRIC DRIVE, X13 MOTOR, 5 TON VERTICAL SUPPLY

SPEED (TORQUE) TAP	CFM	ESP	BHP
1	1500	1.00	0.70
	1625	0.72	0.65
	1750	0.46	0.60
	1875	0.28	0.55
	2000	0.14	0.51
	2125	0.00	0.52
	2250	–	–
	2375	–	–
	2500	–	–
2	1500	1.18	0.88
	1625	1.00	0.90
	1750	0.75	0.87
	1875	0.51	0.83
	2000	0.30	0.79
	2125	0.13	0.75
	2250	–	–
	2375	–	–
	2500	–	–
3	1500	1.19	0.88
	1625	1.03	0.91
	1750	0.80	0.90
	1875	0.56	0.87
	2000	0.35	0.83
	2125	0.19	0.80
	2250	0.01	0.77
	2375	–	–
	2500	–	–
4	1500	1.25	0.89
	1625	1.09	0.93
	1750	0.89	0.96
	1875	0.65	0.94
	2000	0.45	0.93
	2125	0.26	0.89
	2250	0.12	0.86
	2375	–	–
	2500	–	–
5	1500	1.26	0.90
	1625	1.16	0.96
	1750	0.99	1.01
	1875	0.80	1.05
	2000	0.67	1.07
	2125	0.48	1.07
	2250	0.26	1.03
	2375	0.11	1.00
	2500	–	–

APPENDIX III. FAN PERFORMANCE (CONT)

TABLE 22 – 50TCQA04

3 TON HORIZONTAL SUPPLY

CFM	AVAILABLE EXTERNAL STATIC PRESSURE (IN. WG)									
	0.2		0.4		0.6		0.8		1.0	
	RPM	BHP	RPM	BHP	RPM	BHP	RPM	BHP	RPM	BHP
900	574	0.13	707	0.23	817	0.34	913	0.47	999	0.61
975	597	0.15	727	0.25	835	0.37	929	0.50	1015	0.64
1050	621	0.18	747	0.28	853	0.40	946	0.53	1030	0.68
1125	646	0.20	768	0.31	872	0.43	964	0.57	1047	0.72
1200	671	0.23	790	0.34	892	0.47	982	0.61	1064	0.76
1275	696	0.26	812	0.38	912	0.51	1001	0.65	1082	0.81
1350	723	0.30	835	0.42	933	0.55	1020	0.70	1100	0.86
1425	749	0.34	859	0.46	955	0.60	1040	0.75	1119	0.91
1500	776	0.38	883	0.51	977	0.65	1061	0.80	1138	0.97

Med static – 819–1251 RPM, Max BHP 1.5
 High static – 1035–1466 RPM, Max BHP 2.0

CFM	AVAILABLE EXTERNAL STATIC PRESSURE (IN. WG)									
	1.2		1.4		1.6		1.8		2.0	
	RPM	BHP	RPM	BHP	RPM	BHP	RPM	BHP	RPM	BHP
900	1078	0.77	1151	0.93	1220	1.11	1284	1.30	1346	1.49
975	1093	0.80	1165	0.97	1233	1.15	1297	1.33	1358	1.53
1050	1108	0.84	1180	1.01	1247	1.19	1311	1.38	1371	1.58
1125	1123	0.88	1195	1.05	1261	1.23	1325	1.42	1385	1.62
1200	1140	0.92	1210	1.10	1276	1.28	1339	1.47	1399	1.68
1275	1157	0.97	1226	1.15	1292	1.33	1354	1.53	1414	1.73
1350	1174	1.02	1243	1.20	1308	1.39	1370	1.59	1429	1.80
1425	1192	1.08	1260	1.26	1325	1.45	1386	1.65	1444	1.86
1500	1210	1.14	1278	1.33	1342	1.52	1403	1.72	1461	1.93

Med static – 819–1251 RPM, Max BHP 1.5
 High static – 1035–1466 RPM, Max BHP 2.0

TABLE 23 – 50TCQA04

3 TON VERTICAL SUPPLY

CFM	AVAILABLE EXTERNAL STATIC PRESSURE (IN. WG)									
	0.2		0.4		0.6		0.8		1.0	
	RPM	BHP	RPM	BHP	RPM	BHP	RPM	BHP	RPM	BHP
900	594	0.15	740	0.25	867	0.37	981	0.52	1084	0.68
975	618	0.17	758	0.28	881	0.40	991	0.55	1092	0.71
1050	642	0.19	777	0.30	896	0.43	1003	0.58	1102	0.75
1125	668	0.22	797	0.34	912	0.47	1017	0.62	1113	0.79
1200	695	0.25	818	0.37	930	0.51	1032	0.66	1126	0.83
1275	722	0.29	841	0.41	949	0.55	1048	0.71	1140	0.88
1350	750	0.33	864	0.46	968	0.60	1065	0.76	1155	0.93
1425	778	0.37	888	0.50	989	0.65	1083	0.81	1171	0.99
1500	807	0.42	913	0.56	1011	0.71	1103	0.87	1188	1.05

Med static – 819–1251 RPM, Max BHP 1.5
 High static – 1035–1466 RPM, Max BHP 2.0

CFM	AVAILABLE EXTERNAL STATIC PRESSURE (IN. WG)									
	1.2		1.4		1.6		1.8		2.0	
	RPM	BHP	RPM	BHP	RPM	BHP	RPM	BHP	RPM	BHP
900	1180	0.86	1269	1.05	1354	1.25	1434	1.47	1511	1.70
975	1186	0.89	1275	1.08	1358	1.29	1437	1.51	1513	1.74
1050	1194	0.92	1281	1.12	1363	1.32	1441	1.54	1516	1.78
1125	1204	0.97	1289	1.16	1370	1.37	1447	1.59	1520	1.82
1200	1215	1.01	1298	1.21	1378	1.42	1454	1.64	1526	1.87
1275	1227	1.06	1309	1.26	1387	1.47	1462	1.69	1533	1.92
1350	1240	1.12	1321	1.32	1397	1.53	1471	1.75	1541	1.99
1425	1254	1.18	1333	1.38	1409	1.59	1481	1.82	–	–
1500	1270	1.24	1347	1.45	1421	1.66	1492	1.89	–	–

Med static – 819–1251 RPM, Max BHP 1.5
 High static – 1035–1466 RPM, Max BHP 2.0

Bold Face indicates field–supplied drive

Recommend using field–supplied fan pulley (part no. KR11AD561), motor pulley (part no. KR11HY181) and belt (part no. KR29AF041).

APPENDIX III. FAN PERFORMANCE (CONT)

TABLE 24 – 50TCQA05

4 TON HORIZONTAL SUPPLY

CFM	AVAILABLE EXTERNAL STATIC PRESSURE (IN. WG)									
	0.2		0.4		0.6		0.8		1.0	
	RPM	BHP	RPM	BHP	RPM	BHP	RPM	BHP	RPM	BHP
1200	671	0.23	790	0.34	892	0.47	982	0.61	1064	0.76
1300	705	0.28	820	0.39	919	0.52	1007	0.67	1088	0.82
1400	740	0.33	851	0.45	947	0.58	1034	0.73	1113	0.89
1500	776	0.38	883	0.51	977	0.65	1061	0.80	1138	0.97
1600	813	0.45	916	0.58	1007	0.73	1089	0.89	1165	1.05
1700	851	0.52	949	0.66	1038	0.81	1118	0.97	1192	1.15
1800	881	0.60	984	0.75	1069	0.90	1148	1.07	1221	1.25
1900	927	0.69	1019	0.84	1102	1.00	1179	1.18	1250	1.36
2000	965	0.78	1054	0.94	1135	1.11	1210	1.29	1280	1.48

Med static – 920–1303 RPM, Max BHP 1.5

High static – 1035–1466 RPM, Max BHP 2.0

CFM	AVAILABLE EXTERNAL STATIC PRESSURE (IN. WG)									
	1.2		1.4		1.6		1.8		2.0	
	RPM	BHP	RPM	BHP	RPM	BHP	RPM	BHP	RPM	BHP
1200	1140	0.92	1210	1.10	1276	1.28	1339	1.47	1399	1.68
1300	1162	0.99	1232	1.16	1297	1.35	1360	1.55	1419	1.75
1400	1186	1.06	1254	1.24	1319	1.43	1381	1.63	1439	1.84
1500	1210	1.14	1278	1.33	1342	1.52	1403	1.72	1461	1.93
1600	1236	1.23	1302	1.42	1365	1.62	1425	1.82	–	–
1700	1262	1.33	1328	1.52	1390	1.72	1449	1.93	–	–
1800	1289	1.44	1354	1.63	1415	1.84	–	–	–	–
1900	1317	1.55	1380	1.75	1441	1.96	–	–	–	–
2000	1345	1.68	1408	1.88	–	–	–	–	–	–

Med static – 920–1303 RPM, Max BHP 1.5

High static – 1035–1466 RPM, Max BHP 2.0

Bold Face indicates field–supplied drive

Recommend using field–supplied fan pulley (part no. KR11AD561), motor pulley (part no. KR11HY181) and belt (part no. KR29AF041).

TABLE 25 – 50TCQA05

4 TON VERTICAL SUPPLY

CFM	AVAILABLE EXTERNAL STATIC PRESSURE (IN. WG)									
	0.2		0.4		0.6		0.8		1.0	
	RPM	BHP	RPM	BHP	RPM	BHP	RPM	BHP	RPM	BHP
1200	695	0.25	818	0.37	930	0.51	1032	0.66	1126	0.83
1300	731	0.30	849	0.43	955	0.57	1053	0.72	1145	0.89
1400	769	0.36	880	0.49	982	0.63	1077	0.79	1166	0.97
1500	807	0.42	913	0.56	1011	0.71	1103	0.87	1188	1.05
1600	847	0.49	948	0.63	1042	0.79	1130	0.96	1213	1.14
1700	887	0.57	983	0.72	1073	0.88	1158	1.06	1239	1.24
1800	928	0.66	1020	0.82	1106	0.98	1188	1.16	1266	1.35
1900	969	0.76	1057	0.92	1140	1.09	1219	1.28	1295	1.48
2000	1010	0.87	1095	1.04	1175	1.21	1251	1.41	1325	1.61

Med static – 920–1303 RPM, Max BHP 1.5

High static – 1035–1466 RPM, Max BHP 2.0

CFM	AVAILABLE EXTERNAL STATIC PRESSURE (IN. WG)									
	1.2		1.4		1.6		1.8		2.0	
	RPM	BHP	RPM	BHP	RPM	BHP	RPM	BHP	RPM	BHP
1200	1215	1.01	1298	1.21	1378	1.42	1454	1.64	1526	1.87
1300	1231	1.08	1313	1.28	1390	1.49	1465	1.71	1536	1.94
1400	1249	1.16	1329	1.36	1405	1.57	1478	1.79	–	–
1500	1270	1.24	1347	1.45	1421	1.66	1492	1.89	–	–
1600	1292	1.34	1367	1.54	1440	1.76	1509	1.99	–	–
1700	1315	1.44	1389	1.65	1459	1.88	–	–	–	–
1800	1341	1.56	1412	1.77	1481	2.00	–	–	–	–
1900	1367	1.68	1437	1.90	–	–	–	–	–	–
2000	1395	1.82	–	–	–	–	–	–	–	–

Med static – 920–1303 RPM, Max BHP 1.5

High static – 1035–1466 RPM, Max BHP 2.0

Bold Face indicates field–supplied drive

Recommend using field–supplied fan pulley (part no. KR11AD561), motor pulley (part no. KR11HY181) and belt (part no. KR29AF041).

APPENDIX III. FAN PERFORMANCE (CONT)

TABLE 26 – 50TCQA06

5 TON HORIZONTAL SUPPLY

CFM	AVAILABLE EXTERNAL STATIC PRESSURE (IN. WG)									
	0.2		0.4		0.6		0.8		1.0	
	RPM	BHP	RPM	BHP	RPM	BHP	RPM	BHP	RPM	BHP
1500	725	0.33	840	0.46	937	0.60	1023	0.75	1101	0.90
1625	765	0.40	876	0.54	970	0.68	1054	0.84	1131	1.00
1750	806	0.48	912	0.63	1004	0.78	1087	0.94	1162	1.11
1875	847	0.57	950	0.72	1039	0.88	1120	1.05	1194	1.23
2000	889	0.66	988	0.83	1075	1.00	1154	1.18	1226	1.36
2125	931	0.78	1027	0.95	1112	1.13	1189	1.31	1260	1.50
2250	974	0.90	1067	1.08	1149	1.27	1224	1.46	1294	1.66
2375	1018	1.03	1107	1.23	1187	1.43	1261	1.63	1329	1.84
2500	1061	1.19	1148	1.39	1226	1.59	1297	1.81	1364	2.02

Med static – 1066–1380 RPM, Max BHP 2.0

High static – 1208–1639 RPM, Max BHP 2.9

CFM	AVAILABLE EXTERNAL STATIC PRESSURE (IN. WG)									
	1.2		1.4		1.6		1.8		2.0	
	RPM	BHP	RPM	BHP	RPM	BHP	RPM	BHP	RPM	BHP
1500	1172	1.06	1239	1.23	1302	1.40	1361	1.58	1418	1.77
1625	1201	1.16	1267	1.34	1329	1.52	1388	1.71	1444	1.90
1750	1231	1.28	1296	1.46	1358	1.65	1416	1.84	1472	2.04
1875	1262	1.41	1326	1.60	1387	1.79	1445	1.99	1499	2.20
2000	1294	1.55	1357	1.74	1417	1.95	1474	2.15	1528	2.36
2125	1326	1.70	1388	1.90	1447	2.11	1504	2.33	1557	2.55
2250	1359	1.87	1420	2.08	1479	2.29	1534	2.51	1587	2.74
2375	1393	2.05	1453	2.27	1511	2.49	1566	2.72	–	–
2500	1427	2.24	1487	2.47	1543	2.70	–	–	–	–

Med static – 1066–1380 RPM, Max BHP 2.0

High static – 1208–1639 RPM, Max BHP 2.9

TABLE 27 – 50TCQA06

5 TON VERTICAL SUPPLY

CFM	AVAILABLE EXTERNAL STATIC PRESSURE (IN. WG)									
	0.2		0.4		0.6		0.8		1.0	
	RPM	BHP	RPM	BHP	RPM	BHP	RPM	BHP	RPM	BHP
1500	794	0.41	902	0.55	993	0.69	1074	0.85	1147	1.00
1625	840	0.49	945	0.64	1034	0.80	1113	0.96	1185	1.13
1750	888	0.59	988	0.75	1075	0.92	1153	1.09	1223	1.26
1875	936	0.70	1033	0.87	1117	1.05	1193	1.23	1263	1.41
2000	984	0.82	1078	1.00	1160	1.19	1235	1.39	1303	1.58
2125	1033	0.96	1124	1.15	1204	1.35	1277	1.56	1343	1.76
2250	1083	1.11	1170	1.32	1248	1.53	1319	1.74	1385	1.96
2375	1133	1.28	1217	1.50	1293	1.72	1363	1.95	1427	2.17
2500	1183	1.47	1265	1.70	1339	1.93	1406	2.17	1470	2.41

Med static – 1066–1380 RPM, Max BHP 2.0

High static – 1208–1639 RPM, Max BHP 2.9

CFM	AVAILABLE EXTERNAL STATIC PRESSURE (IN. WG)									
	1.2		1.4		1.6		1.8		2.0	
	RPM	BHP	RPM	BHP	RPM	BHP	RPM	BHP	RPM	BHP
1500	1214	1.16	1277	1.33	1336	1.50	1392	1.67	1445	1.85
1625	1251	1.30	1313	1.47	1371	1.65	1427	1.83	1479	2.02
1750	1289	1.44	1350	1.63	1407	1.81	1462	2.01	1514	2.20
1875	1327	1.60	1387	1.80	1444	1.99	1498	2.19	1550	2.40
2000	1366	1.78	1426	1.98	1482	2.19	1535	2.40	1586	2.61
2125	1406	1.97	1464	2.18	1520	2.40	1573	2.62	1623	2.84
2250	1446	2.18	1504	2.40	1559	2.62	1611	2.85	–	–
2375	1487	2.40	1544	2.63	1598	2.87	–	–	–	–
2500	1529	2.64	1585	2.89	–	–	–	–	–	–

Med static – 1066–1380 RPM, Max BHP 2.0

High static – 1208–1639 RPM, Max BHP 2.9

APPENDIX III. FAN PERFORMANCE (CONT)

TABLE 28 – 50TCQA07

6 TON HORIZONTAL SUPPLY

CFM	AVAILABLE EXTERNAL STATIC PRESSURE (IN. WG)									
	0.2		0.4		0.6		0.8		1.0	
	RPM	BHP	RPM	BHP	RPM	BHP	RPM	BHP	RPM	BHP
1800	822	0.51	927	0.66	1018	0.82	1100	0.98	1174	1.15
1950	872	0.62	973	0.79	1061	0.95	1140	1.13	1213	1.31
2100	923	0.75	1019	0.92	1104	1.10	1182	1.29	1253	1.48
2250	974	0.90	1067	1.08	1149	1.27	1224	1.46	1294	1.66
2400	1026	1.06	1115	1.26	1195	1.46	1268	1.66	1336	1.87
2550	1079	1.25	1164	1.46	1241	1.67	1312	1.88	1379	2.10
2700	1132	1.46	1214	1.67	1289	1.90	1358	2.12	1422	2.35
2850	1186	1.69	1264	1.92	1336	2.15	1404	2.39	1467	2.63
3000	1240	1.94	1315	2.18	1385	2.43	1451	2.68	1512	2.93

Std static – 878–1192 RPM, Max BHP 1.5
 Med static – 1066–1380 RPM, Max BHP 2.9
 High static – 1208–1639 RPM, Max BHP 2.9

CFM	AVAILABLE EXTERNAL STATIC PRESSURE (IN. WG)									
	1.2		1.4		1.6		1.8		2.0	
	RPM	BHP	RPM	BHP	RPM	BHP	RPM	BHP	RPM	BHP
1800	1244	1.33	1308	1.51	1369	1.70	1427	1.90	1483	2.10
1950	1281	1.49	1345	1.68	1405	1.88	1462	2.09	1517	2.30
2100	1320	1.67	1382	1.87	1441	2.08	1498	2.29	1552	2.51
2250	1359	1.87	1420	2.08	1479	2.29	1534	2.51	1587	2.74
2400	1400	2.09	1460	2.31	1517	2.53	1572	2.76	–	–
2550	1441	2.33	1500	2.55	1557	2.79	–	–	–	–
2700	1483	2.59	1541	2.83	–	–	–	–	–	–
2850	1527	2.87	–	–	–	–	–	–	–	–
3000	–	–	–	–	–	–	–	–	–	–

Std static – 878–1192 RPM, Max BHP 1.5
 Med static – 1066–1380 RPM, Max BHP 2.9
 High static – 1208–1639 RPM, Max BHP 2.9

TABLE 29 – 50TCQA07

6 TON VERTICAL SUPPLY

CFM	AVAILABLE EXTERNAL STATIC PRESSURE (IN. WG)									
	0.2		0.4		0.6		0.8		1.0	
	RPM	BHP	RPM	BHP	RPM	BHP	RPM	BHP	RPM	BHP
1800	907	0.63	1006	0.80	1092	0.97	1169	1.14	1239	1.32
1950	965	0.77	1060	0.95	1143	1.13	1218	1.32	1287	1.51
2100	1024	0.93	1115	1.12	1195	1.32	1268	1.52	1335	1.72
2250	1083	1.11	1170	1.32	1248	1.53	1319	1.74	1385	1.96
2400	1143	1.32	1227	1.54	1302	1.76	1371	1.99	1435	2.22
2550	1203	1.55	1284	1.78	1357	2.02	1424	2.26	1487	2.50
2700	1264	1.81	1342	2.06	1412	2.31	1478	2.56	1539	2.82
2850	1326	2.09	1400	2.36	1469	2.62	1532	2.89	–	–
3000	1387	2.41	1459	2.69	–	–	–	–	–	–

Std static – 878–1192 RPM, Max BHP 1.5
 Med static – 1066–1380 RPM, Max BHP 2.9
 High static – 1208–1639 RPM, Max BHP 2.9

CFM	AVAILABLE EXTERNAL STATIC PRESSURE (IN. WG)									
	1.2		1.4		1.6		1.8		2.0	
	RPM	BHP	RPM	BHP	RPM	BHP	RPM	BHP	RPM	BHP
1800	1304	1.51	1365	1.69	1422	1.88	1477	2.08	1528	2.28
1950	1350	1.71	1410	1.91	1467	2.11	1520	2.31	1572	2.52
2100	1398	1.93	1457	2.14	1512	2.35	1565	2.57	1616	2.79
2250	1446	2.18	1504	2.40	1559	2.62	1611	2.85	–	–
2400	1496	2.45	1552	2.68	–	–	–	–	–	–
2550	1546	2.75	–	–	–	–	–	–	–	–
2700	–	–	–	–	–	–	–	–	–	–
2850	–	–	–	–	–	–	–	–	–	–
3000	–	–	–	–	–	–	–	–	–	–

Std static – 878–1192 RPM, Max BHP 1.5
 Med static – 1066–1380 RPM, Max BHP 2.9
 High static – 1208–1639 RPM, Max BHP 2.9

APPENDIX III. FAN PERFORMANCE (CONT)

TABLE 30 – 50TCQD08

7.5 TON HORIZONTAL SUPPLY

CFM	AVAILABLE EXTERNAL STATIC PRESSURE (IN. WG)									
	0.2		0.4		0.6		0.8		1.0	
	RPM	BHP	RPM	BHP	RPM	BHP	RPM	BHP	RPM	BHP
2250	423	0.28	509	0.40	587	0.52	659	0.66	725	0.80
2438	444	0.34	525	0.46	600	0.59	669	0.73	733	0.88
2625	465	0.40	543	0.53	614	0.67	680	0.82	743	0.97
2813	487	0.47	561	0.61	629	0.76	693	0.91	753	1.08
3000	510	0.55	580	0.70	646	0.86	707	1.02	765	1.19
3188	534	0.65	600	0.80	663	0.96	722	1.13	779	1.31
3375	557	0.75	621	0.91	681	1.08	738	1.26	793	1.44
3563	582	0.86	642	1.03	700	1.21	755	1.39	808	1.58
3750	606	0.99	664	1.17	720	1.35	773	1.54	824	1.74

Std static – 460–652 RPM, Max BHP 1.2
 Med static – 591–838 RPM, Max BHP 2.9
 High static – 838–1084 RPM, Max BHP 2.9

CFM	AVAILABLE EXTERNAL STATIC PRESSURE (IN. WG)									
	1.2		1.4		1.6		1.8		2.0	
	RPM	BHP	RPM	BHP	RPM	BHP	RPM	BHP	RPM	BHP
2250	788	0.94	847	1.09	903	1.25	957	1.41	1009	1.58
2438	794	1.03	852	1.19	907	1.36	959	1.52	1010	1.70
2625	802	1.13	858	1.30	911	1.47	963	1.64	1012	1.82
2813	811	1.24	865	1.41	917	1.59	967	1.77	1016	1.96
3000	821	1.36	874	1.54	925	1.72	974	1.91	1021	2.11
3188	832	1.49	884	1.68	933	1.87	981	2.06	1028	2.26
3375	845	1.63	895	1.82	943	2.02	990	2.22	1035	2.43
3563	858	1.78	907	1.98	954	2.19	1000	2.40	1044	2.61
3750	873	1.94	920	2.15	966	2.36	1011	2.58	1054	2.80

Std static – 460–652 RPM, Max BHP 1.2
 Med static – 591–838 RPM, Max BHP 2.9
 High static – 838–1084 RPM, Max BHP 2.9

TABLE 31 – 50TCQD08

7.5 TON VERTICAL SUPPLY

CFM	AVAILABLE EXTERNAL STATIC PRESSURE (IN. WG)									
	0.2		0.4		0.6		0.8		1.0	
	RPM	BHP	RPM	BHP	RPM	BHP	RPM	BHP	RPM	BHP
2250	447	0.31	528	0.43	597	0.54	658	0.66	713	0.78
2438	470	0.37	548	0.50	615	0.62	675	0.75	729	0.88
2625	494	0.45	569	0.58	634	0.71	692	0.85	745	0.99
2813	518	0.53	590	0.67	653	0.82	710	0.96	763	1.11
3000	543	0.62	612	0.77	673	0.93	729	1.08	780	1.24
3188	568	0.72	635	0.89	694	1.05	749	1.21	799	1.38
3375	593	0.84	658	1.01	716	1.19	769	1.36	818	1.53
3563	619	0.97	681	1.15	737	1.33	789	1.52	837	1.70
3750	645	1.11	705	1.30	760	1.49	810	1.68	857	1.88

Std static – 460–652 RPM, Max BHP 1.2
 Med static – 591–838 RPM, Max BHP 2.9
 High static – 838–1084 RPM, Max BHP 2.9

CFM	AVAILABLE EXTERNAL STATIC PRESSURE (IN. WG)									
	1.2		1.4		1.6		1.8		2.0	
	RPM	BHP	RPM	BHP	RPM	BHP	RPM	BHP	RPM	BHP
2250	764	0.89	812	1.02	856	1.14	899	1.26	939	1.39
2438	779	1.00	826	1.13	870	1.26	912	1.40	952	1.53
2625	795	1.12	841	1.26	885	1.40	926	1.54	966	1.68
2813	811	1.25	857	1.40	900	1.55	941	1.69	980	1.84
3000	828	1.39	873	1.55	916	1.70	956	1.86	995	2.02
3188	846	1.54	890	1.71	932	1.87	972	2.04	1010	2.21
3375	864	1.70	907	1.88	949	2.05	988	2.23	1026	2.40
3563	882	1.88	925	2.06	966	2.25	1005	2.43	1042	2.62
3750	902	2.07	944	2.26	984	2.45	1022	2.65	1059	2.84

Std static – 460–652 RPM, Max BHP 1.2
 Med static – 591–838 RPM, Max BHP 2.9
 High static – 838–1084 RPM, Max BHP 2.9

APPENDIX III. FAN PERFORMANCE (CONT)

TABLE 32 – 50TCQD09

8.5 TON HORIZONTAL SUPPLY

CFM	AVAILABLE EXTERNAL STATIC PRESSURE (IN. WG)									
	0.2		0.4		0.6		0.8		1.0	
	RPM	BHP	RPM	BHP	RPM	BHP	RPM	BHP	RPM	BHP
2550	468	0.39	546	0.52	618	0.66	684	0.80	747	0.96
2763	493	0.47	567	0.61	635	0.76	699	0.91	760	1.07
2975	520	0.57	589	0.72	654	0.87	716	1.03	774	1.20
3188	547	0.68	613	0.83	675	1.00	733	1.17	789	1.34
3400	575	0.80	637	0.96	696	1.14	752	1.31	806	1.50
3613	603	0.94	662	1.11	719	1.29	773	1.48	824	1.67
3825	631	1.09	688	1.27	742	1.46	794	1.66	843	1.86
4038	660	1.26	714	1.45	766	1.65	816	1.85	864	2.06
4250	689	1.45	741	1.65	790	1.86	838	2.07	885	2.29

Std static – 460–652 RPM, Max BHP 1.2

Med static – 591–838 RPM, Max BHP 2.9

High static – 838–1084 RPM, Max BHP 2.9

CFM	AVAILABLE EXTERNAL STATIC PRESSURE (IN. WG)									
	1.2		1.4		1.6		1.8		2.0	
	RPM	BHP	RPM	BHP	RPM	BHP	RPM	BHP	RPM	BHP
2550	806	1.11	863	1.28	916	1.45	968	1.62	1018	1.80
2763	817	1.24	871	1.41	924	1.59	974	1.77	1022	1.95
2975	829	1.37	882	1.55	932	1.74	981	1.93	1028	2.12
3188	843	1.53	894	1.71	943	1.90	990	2.10	1036	2.30
3400	858	1.69	907	1.88	955	2.09	1001	2.29	1046	2.50
3613	874	1.87	922	2.07	968	2.28	1013	2.49	1057	2.71
3825	891	2.07	938	2.28	983	2.49	1027	2.71	–	–
4038	910	2.28	955	2.50	999	2.72	1041	2.95	–	–
4250	930	2.51	973	2.74	1015	2.97	1057	3.21	–	–

Std static – 460–652 RPM, Max BHP 1.2

Med static – 591–838 RPM, Max BHP 2.9

High static – 838–1084 RPM, Max BHP 2.9

TABLE 33 – 50TCQD09

8.5 VERTICAL SUPPLY

CFM	AVAILABLE EXTERNAL STATIC PRESSURE (IN. WG)									
	0.2		0.4		0.6		0.8		1.0	
	RPM	BHP	RPM	BHP	RPM	BHP	RPM	BHP	RPM	BHP
2550	495	0.43	570	0.56	634	0.70	693	0.83	746	0.96
2763	524	0.53	595	0.67	657	0.81	714	0.95	766	1.09
2975	552	0.63	620	0.79	681	0.94	736	1.09	787	1.24
3188	582	0.76	647	0.92	705	1.08	759	1.25	808	1.41
3400	611	0.89	674	1.07	730	1.24	782	1.42	831	1.59
3613	641	1.05	701	1.23	756	1.42	806	1.60	854	1.79
3825	672	1.22	729	1.42	782	1.61	831	1.81	877	2.00
4038	702	1.41	758	1.62	809	1.83	857	2.03	901	2.24
4250	733	1.62	787	1.84	836	2.06	883	2.28	926	2.49

Std static – 460–652 RPM, Max BHP 1.2

Med static – 591–838 RPM, Max BHP 2.9

High static – 838–1084 RPM, Max BHP 2.9

CFM	AVAILABLE EXTERNAL STATIC PRESSURE (IN. WG)									
	1.2		1.4		1.6		1.8		2.0	
	RPM	BHP	RPM	BHP	RPM	BHP	RPM	BHP	RPM	BHP
2550	795	1.09	841	1.23	885	1.36	926	1.50	965	1.64
2763	814	1.24	859	1.38	902	1.53	943	1.68	982	1.82
2975	834	1.40	878	1.55	921	1.71	961	1.86	999	2.02
3188	855	1.57	898	1.74	940	1.90	979	2.07	1017	2.24
3400	876	1.76	919	1.94	960	2.12	998	2.29	1036	2.47
3613	898	1.97	940	2.16	980	2.34	1018	2.53	1055	2.72
3825	921	2.20	962	2.40	1001	2.59	1039	2.79	–	–
4038	944	2.45	984	2.65	1023	2.86	–	–	–	–
4250	968	2.71	–	–	–	–	–	–	–	–

Std static – 460–652 RPM, Max BHP 1.2

Med static – 591–838 RPM, Max BHP 2.9

High static – 838–1084 RPM, Max BHP 2.9

APPENDIX III. FAN PERFORMANCE (CONT)

TABLE 34 – 50TCQD12

10 TON HORIZONTAL SUPPLY

CFM	AVAILABLE EXTERNAL STATIC PRESSURE (IN. WG)									
	0.2		0.4		0.6		0.8		1.0	
	RPM	BHP	RPM	BHP	RPM	BHP	RPM	BHP	RPM	BHP
3000	523	0.58	592	0.73	657	0.88	718	1.05	775	1.22
3250	555	0.71	620	0.87	681	1.04	739	1.21	794	1.39
3500	588	0.86	649	1.03	707	1.21	762	1.39	815	1.58
3750	621	1.03	679	1.21	734	1.40	786	1.59	837	1.79
4000	655	1.23	709	1.42	761	1.61	812	1.82	860	2.03
4250	689	1.45	741	1.65	790	1.86	838	2.07	885	2.29
4500	723	1.69	773	1.90	820	2.12	866	2.35	910	2.57
4750	758	1.96	805	2.19	850	2.42	894	2.65	937	2.89
5000	793	2.26	838	2.50	881	2.74	923	2.98	965	3.23

Std static – 591–839 RPM, Max BHP 1.2
 Med static – 733–949 RPM, Max BHP 2.9
 High static – 838–1084 RPM, Max BHP 3.7

CFM	AVAILABLE EXTERNAL STATIC PRESSURE (IN. WG)									
	1.2		1.4		1.6		1.8		2.0	
	RPM	BHP	RPM	BHP	RPM	BHP	RPM	BHP	RPM	BHP
3000	830	1.39	883	1.57	934	1.76	982	1.95	1029	2.14
3250	847	1.57	897	1.76	946	1.96	993	2.16	1039	2.36
3500	865	1.77	914	1.97	961	2.18	1007	2.38	1051	2.60
3750	885	1.99	932	2.20	978	2.42	1022	2.64	1065	2.86
4000	907	2.24	952	2.46	996	2.68	1038	2.91	1080	3.14
4250	930	2.51	973	2.74	1015	2.97	1057	3.21	1097	3.45
4500	954	2.81	996	3.05	1037	3.29	1076	3.54	1115	3.79
4750	979	3.13	1019	3.38	1059	3.63	1097	3.89	–	–
5000	1005	3.49	1044	3.74	1082	4.01	–	–	–	–

Std static – 591–839 RPM, Max BHP 2.4
 Med static – 733–949 RPM, Max BHP 2.9
 High static – 838–1084 RPM, Max BHP 3.7

TABLE 35 – 50TCQD12

10 VERTICAL SUPPLY

CFM	AVAILABLE EXTERNAL STATIC PRESSURE (IN. WG)									
	0.2		0.4		0.6		0.8		1.0	
	RPM	BHP	RPM	BHP	RPM	BHP	RPM	BHP	RPM	BHP
3000	556	0.65	623	0.80	684	0.95	738	1.11	789	1.26
3250	590	0.79	655	0.96	713	1.13	766	1.29	815	1.46
3500	625	0.96	687	1.14	742	1.32	794	1.50	841	1.68
3750	661	1.16	719	1.35	773	1.54	822	1.73	869	1.93
4000	697	1.37	753	1.58	804	1.79	852	1.99	897	2.20
4250	733	1.62	787	1.84	836	2.06	883	2.28	926	2.49
4500	770	1.89	821	2.13	869	2.36	914	2.59	956	2.82
4750	807	2.20	856	2.45	902	2.69	945	2.94	986	3.18
5000	844	2.54	891	2.80	936	3.06	978	3.31	1018	3.57

Std static – 591–839 RPM, Max BHP 2.4
 Med static – 733–949 RPM, Max BHP 2.9
 High static – 838–1084 RPM, Max BHP 3.7

CFM	AVAILABLE EXTERNAL STATIC PRESSURE (IN. WG)									
	1.2		1.4		1.6		1.8		2.0	
	RPM	BHP	RPM	BHP	RPM	BHP	RPM	BHP	RPM	BHP
3000	836	1.42	881	1.57	923	1.73	963	1.89	1001	2.05
3250	861	1.63	904	1.79	945	1.96	985	2.13	1023	2.30
3500	886	1.86	929	2.04	969	2.22	1008	2.40	1045	2.58
3750	912	2.12	954	2.31	994	2.50	1031	2.70	1068	2.89
4000	940	2.40	980	2.61	1019	2.81	1056	3.02	1092	3.22
4250	968	2.71	1007	2.93	1045	3.15	1081	3.36	1117	3.58
4500	996	3.05	1035	3.28	1072	3.51	1108	3.74	1142	3.97
4750	1026	3.42	1063	3.66	1100	3.91	–	–	–	–
5000	1056	3.82	–	–	–	–	–	–	–	–

Std static – 591–839 RPM, Max BHP 2.4
 Med static – 733–949 RPM, Max BHP 2.9
 High static – 838–1084 RPM, Max BHP 3.7

APPENDIX III. FAN PERFORMANCE (CONT)

TABLE 36 – 50TCQD14

12.5 TON HORIZONTAL SUPPLY

CFM	AVAILABLE EXTERNAL STATIC PRESSURE (IN. WG)									
	0.2		0.4		0.6		0.8		1.0	
	RPM	BHP	RPM	BHP	RPM	BHP	RPM	BHP	RPM	BHP
3750	381	0.53	452	0.74	520	0.98	584	1.26	645	1.56
4063	401	0.63	468	0.86	531	1.11	592	1.39	651	1.69
4375	421	0.75	484	0.99	544	1.25	601	1.53	657	1.85
4688	441	0.89	501	1.14	558	1.40	612	1.70	666	2.02
5000	462	1.04	519	1.30	573	1.58	625	1.88	675	2.21
5313	483	1.21	537	1.49	589	1.77	638	2.08	686	2.42
5625	504	1.40	556	1.69	605	1.99	653	2.31	699	2.65
5938	525	1.61	575	1.91	622	2.22	668	2.55	712	2.90
6250	546	1.84	595	2.15	640	2.48	684	2.82	726	3.17

Std static – 507–676 RPM, Max BHP 2.9

Med static – 634–833 RPM, Max BHP 2.9

High static – 792–971 RPM, 208V: Max BHP 5.0; 230V/460V: Max BHP 6.1; 575V: Max BHP 5.9

Bold Face requires standard static drive package with KR11HY153 (1VP34) motor pulley (338–507)

Italics requires high static drive package with KR11HY186 (1VM50) motor pulley (684–864)

CFM	AVAILABLE EXTERNAL STATIC PRESSURE (IN. WG)											
	1.2		1.4		1.6		1.8		1.9		2.0	
	RPM	BHP	RPM	BHP	RPM	BHP	RPM	BHP	RPM	BHP	RPM	BHP
3750	703	1.88	757	2.23	808	2.59	855	2.97	878	3.17	900	3.36
4063	707	2.03	760	2.38	810	2.75	857	3.14	880	3.34	902	3.55
4375	711	2.18	763	2.55	812	2.93	859	3.33	882	3.53	904	3.74
4688	717	2.36	767	2.73	815	3.12	862	3.52	884	3.73	906	3.94
5000	725	2.55	773	2.93	820	3.32	865	3.73	887	3.95	908	4.16
5313	734	2.77	780	3.15	825	3.55	869	3.96	890	4.18	912	4.40
5625	744	3.01	788	3.39	832	3.79	874	4.22	895	4.44	916	4.66
5938	755	3.27	798	3.65	840	4.06	881	4.49	901	4.71	921	4.94
6250	768	3.55	808	3.94	849	4.36	888	4.79	908	5.01	927	5.24

Std static – 507–676 RPM, Max BHP 2.9

Med static – 634–833 RPM, Max BHP 2.9

High static – 792–971 RPM, 208V: Max BHP 5.0; 230V/460V: Max BHP 6.1; 575V: Max BHP 5.9

Italics requires high static drive package with KR11HY186 (1VM50) motor pulley (684–864)

TABLE 37 – 50TCQD14

12.5 VERTICAL SUPPLY

CFM	AVAILABLE EXTERNAL STATIC PRESSURE (IN. WG)									
	0.2		0.4		0.6		0.8		1.0	
	RPM	BHP	RPM	BHP	RPM	BHP	RPM	BHP	RPM	BHP
3750	441	0.65	513	0.88	582	1.15	647	1.45	707	1.78
4063	466	0.78	533	1.03	598	1.30	660	1.61	718	1.95
4375	491	0.94	554	1.19	615	1.48	674	1.80	730	2.14
4688	517	1.11	576	1.38	634	1.68	690	2.00	744	2.36
5000	543	1.31	599	1.59	653	1.90	706	2.23	758	2.59
5313	570	1.54	622	1.82	674	2.14	724	2.48	774	2.85
5625	596	1.78	646	2.08	695	2.41	743	2.76	790	3.14
5938	623	2.06	671	2.37	717	2.71	763	3.07	808	3.45
6250	650	2.36	695	2.69	740	3.03	784	3.40	827	3.80

Std static – 507–676 RPM, Max BHP 2.9

Med static – 634–833 RPM, Max BHP 2.9

High static – 792–971 RPM, 208V: Max BHP 5.0; 230V/460V: Max BHP 6.1; 575V: Max BHP 5.9

Bold Face requires standard static drive package with KR11HY153 (1VP34) motor pulley (338–507)

Italics requires high static drive package with KR11HY186 (1VM50) motor pulley (684–864)

CFM	AVAILABLE EXTERNAL STATIC PRESSURE (IN. WG)											
	1.2		1.4		1.6		1.8		1.9		2.0	
	RPM	BHP	RPM	BHP	RPM	BHP	RPM	BHP	RPM	BHP	RPM	BHP
3750	764	2.12	816	2.48	866	2.86	912	3.24	935	3.44	956	3.64
4063	773	2.31	825	2.68	874	3.07	921	3.47	943	3.68	965	3.88
4375	784	2.51	835	2.90	883	3.30	929	3.72	951	3.93	973	4.14
4688	795	2.73	845	3.13	893	3.54	938	3.98	960	4.19	981	4.42
5000	808	2.98	856	3.38	903	3.81	947	4.25	969	4.48	990	4.71
5313	822	3.25	868	3.66	914	4.10	957	4.55	978	4.78	999	5.02
5625	837	3.54	882	3.96	925	4.41	968	4.87	989	5.11	1009	5.35
5938	852	3.86	896	4.30	938	4.75	980	5.22	1000	5.46	1020	5.71
6250	869	4.22	911	4.65	952	5.12	992	5.59	1012	5.84	1032	6.09

Std static – 507–676 RPM, Max BHP 2.9

Med static – 634–833 RPM, Max BHP 2.9

High static – 792–971 RPM, 208V: Max BHP 5.0; 230V/460V: Max BHP 6.1; 575V: Max BHP 5.9

Bold Face requires standard static drive package with KR11HY153 (1VP34) motor pulley (338–507)

Italics requires high static drive package with KR11HY186 (1VM50) motor pulley (684–864)

Underline requires high static drive package with KR11HY194 (1VP60) motor pulley (864–1061).

APPENDIX III. FAN PERFORMANCE (CONT)

TABLE 38 – PULLEY ADJUSTMENT – BELT DRIVE

UNIT	MOTOR/DRIVE COMBO	MOTOR PULLEY TURNS OPEN											5.5	6
		0	0.5	1	1.5	2	2.5	3	3.5	4	4.5	5		
04	3 phase Medium Static	1251	1208	1165	1121	1078	1035	992	949	905	862	819	–	–
	3 phase High Static	1466	1423	1380	1337	1294	1251	1207	1164	1121	1078	1035	–	–
05	3 phase Medium Static	1303	1265	1226	1188	1150	1112	1073	1035	997	958	920	–	–
	3 phase High Static	1466	1423	1380	1337	1294	1251	1207	1164	1121	1078	1035	–	–
06	3 phase Medium Static	1380	1349	1317	1286	1254	1223	1192	1160	1129	1097	1066	–	–
	3 phase High Static	1639	1596	1553	1510	1467	1424	1380	1337	1294	1251	1208	–	–
07	3 phase Standard Static	1192	1161	1129	1098	1066	1035	1004	972	941	909	878	–	–
	3 phase Medium Static	1380	1349	1317	1286	1254	1223	1192	1160	1129	1097	1066	–	–
	3 phase High Static	1639	1596	1553	1510	1467	1424	1380	1337	1294	1251	1208	–	–
08	3 phase Standard Static	652	633	614	594	575	556	537	518	498	479	460	–	–
	3 phase Medium Static	838	813	789	764	739	715	690	665	640	616	591	–	–
	3 phase High Static	1084	1059	1035	1010	986	961	936	912	887	863	838	–	–
09	3 phase Standard Static	652	633	614	594	575	556	537	518	498	479	460	–	–
	3 phase Medium Static	838	813	789	764	739	715	690	665	640	616	591	–	–
	3 phase High Static	1084	1059	1035	1010	986	961	936	912	887	863	838	–	–
12	3 phase Standard Static	652	633	614	594	575	556	537	518	498	479	460	–	–
	3 phase Medium Static	838	813	789	764	739	715	690	665	640	616	591	–	–
	3 phase High Static	1084	1059	1035	1010	986	961	936	912	887	863	838	–	–
14	3 phase Standard Static	676	659	642	625	608	592	575	558	541	524	507	*	*
	3 phase Medium Static	**	**	833	813	793	773	753	734	714	694	674	654	634
	3 phase High Static	**	**	971	953	935	917	899	882	864	846	828	810	792

NOTE: Do not adjust pulley further than 5 turns open.

■ – Factory settings

* Do not set motor pulley above 5 turns open for A or AX section belts

** Do not set motor pulley below 1 turn open for B or BX section belts

APPENDIX IV. WIRING DIAGRAMS

Wiring Diagrams

50TCQA				
SIZE	TON	VOLTAGE	CONTROL	POWER
A04	3	208/230-1-60	48TM501434-J	48TM501435-L
		208/230-3-60	48TM501434-J	48TM501436-L
		460-3-60	48TM501434-J	48TM501515-J
		575-3-60	48TM501520-J	48TM501516-J
A05	4	208/230-1-60	48TM501434-J	48TM501435-L
		208/230-3-60	48TM501434-J	48TM501436-L
		460-3-60	48TM501434-J	48TM501515-J
		575-3-60	48TM501520-J	48TM501516-J
A06	5	208/230-1-60	48TM501434-J	48TM501435-L
		208/230-3-60	48TM501434-J	48TM501436-L
		460-3-60	48TM501434-J	48TM501515-J
		575-3-60	48TM501520-J	48TM501516-J
A07	6	208/230-1-60	48TM501434-J	48TM501435-L
		208/230-3-60	48TM501434-J	48TM501436-L
		460-3-60	48TM501434-J	48TM501515-J
		575-3-60	48TM501520-J	48TM501516-J

50TCQD				
SIZE	TON	VOLTAGE	CONTROL	POWER
D08	7	208/230-3-60	48TM501370-O	48TM501371-L
		460-3-60	48TM501370-O	48TM501371-L
		575-3-60	48TM501370-O	48TM501371-L
D09	8.5	208/230-3-60	48TM501370-O	48TM501371-L
		460-3-60	48TM501370-O	48TM501371-L
		575-3-60	48TM501370-O	48TM501371-L
D12	10	208/230-3-60	48TM501926-K	48TM501927-G
		460-3-60	48TM501926-K	48TM501958-G
		575-3-60	48TM501926-K	48TM501958-G
D14	12.5	208/230-3-60	50TM500814-P	50TM500628-J
		460-3-60	50TM500814-P	50TM500634-H
		575-3-60	50TM500814-P	50TM500634-H
		PremierLink*	48TM501529-H	
		RTU Open*	50HE500751-J	

NOTE: Component arrangement on Control; Legend on Power Schematic

* PremierLink and RTU OPEN control labels overlay a portion of the base unit control label. The base unit label drawing and the control option drawing are required to provide a complete unit control diagram.

APPENDIX IV. WIRING DIAGRAMS (CONT)

HP CONTROL 208/230V, 460V
3-6TON HP T1

48TMS01434 J

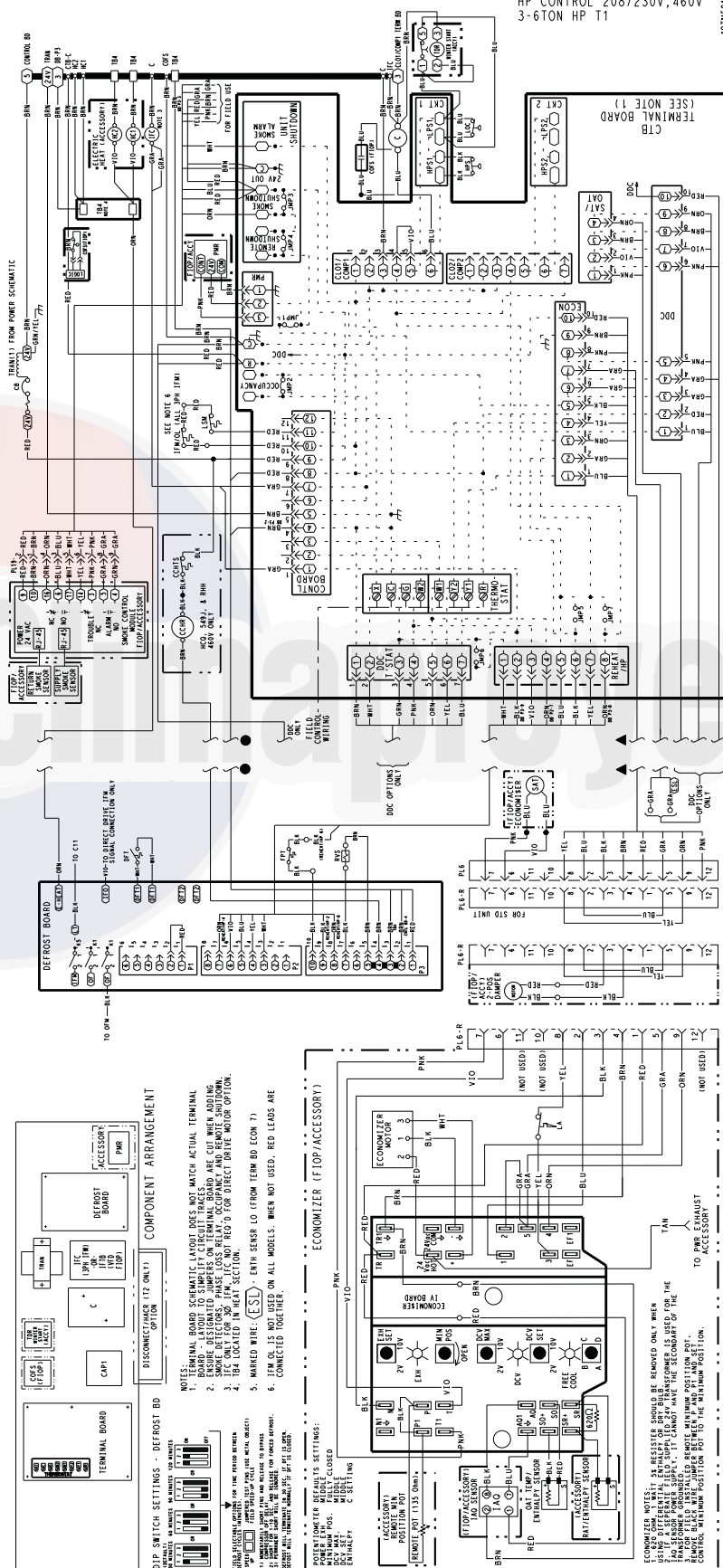

Fig. 58 – 50TCQ A04/A05/A06/A07 Control Wiring Diagram – 208/230–1–60; 208/230–3–60; 460–3–60

APPENDIX IV. WIRING DIAGRAMS (CONT)

HP CONTROL 575V
3-6TON HP T1

487MS01520 J

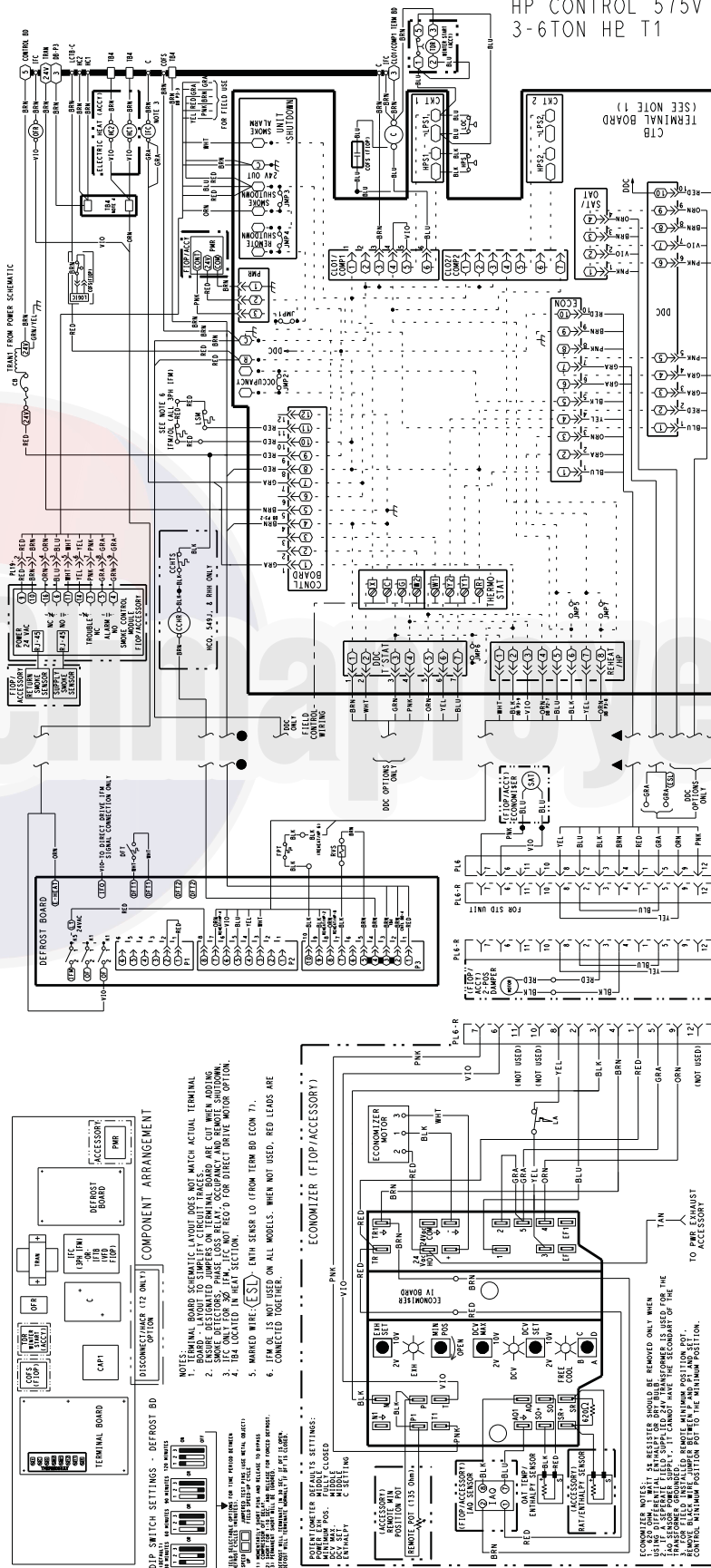
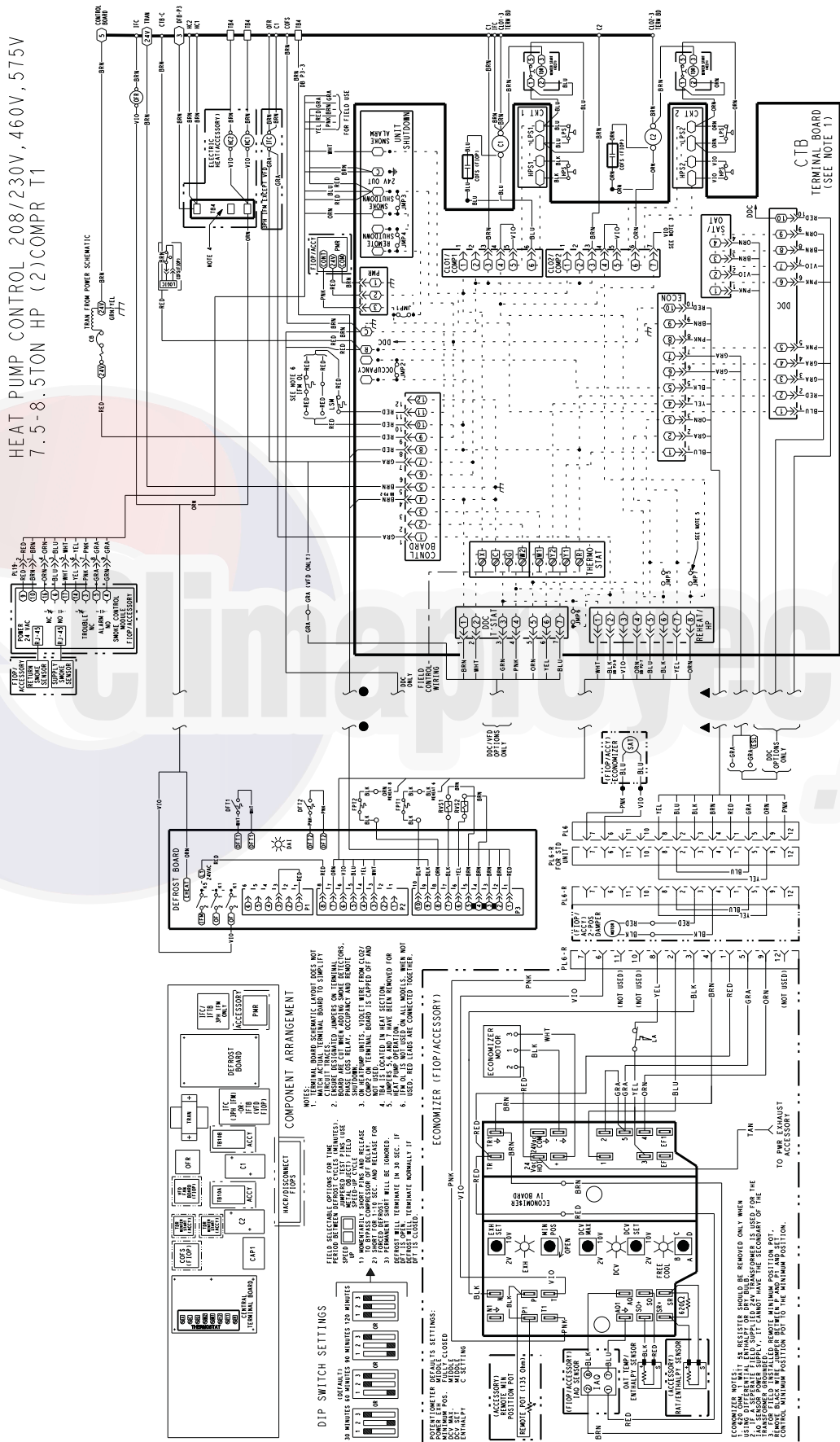

Fig. 59 - 50TCQ A04/A05/A06/A07 Control Wiring Diagram - 575-3-60

APPENDIX IV. WIRING DIAGRAMS (CONT)

HEAT PUMP CONTROL 208/230V, 460V, 575V
7.5-8.5TON HP (2)COMPR T1



481501370 0

Fig. 60 - 50TCQ D08/D09 Control Wiring Diagram - 208/230-3-60; 460-3-60; 575-3-60

APPENDIX IV. WIRING DIAGRAMS (CONT)

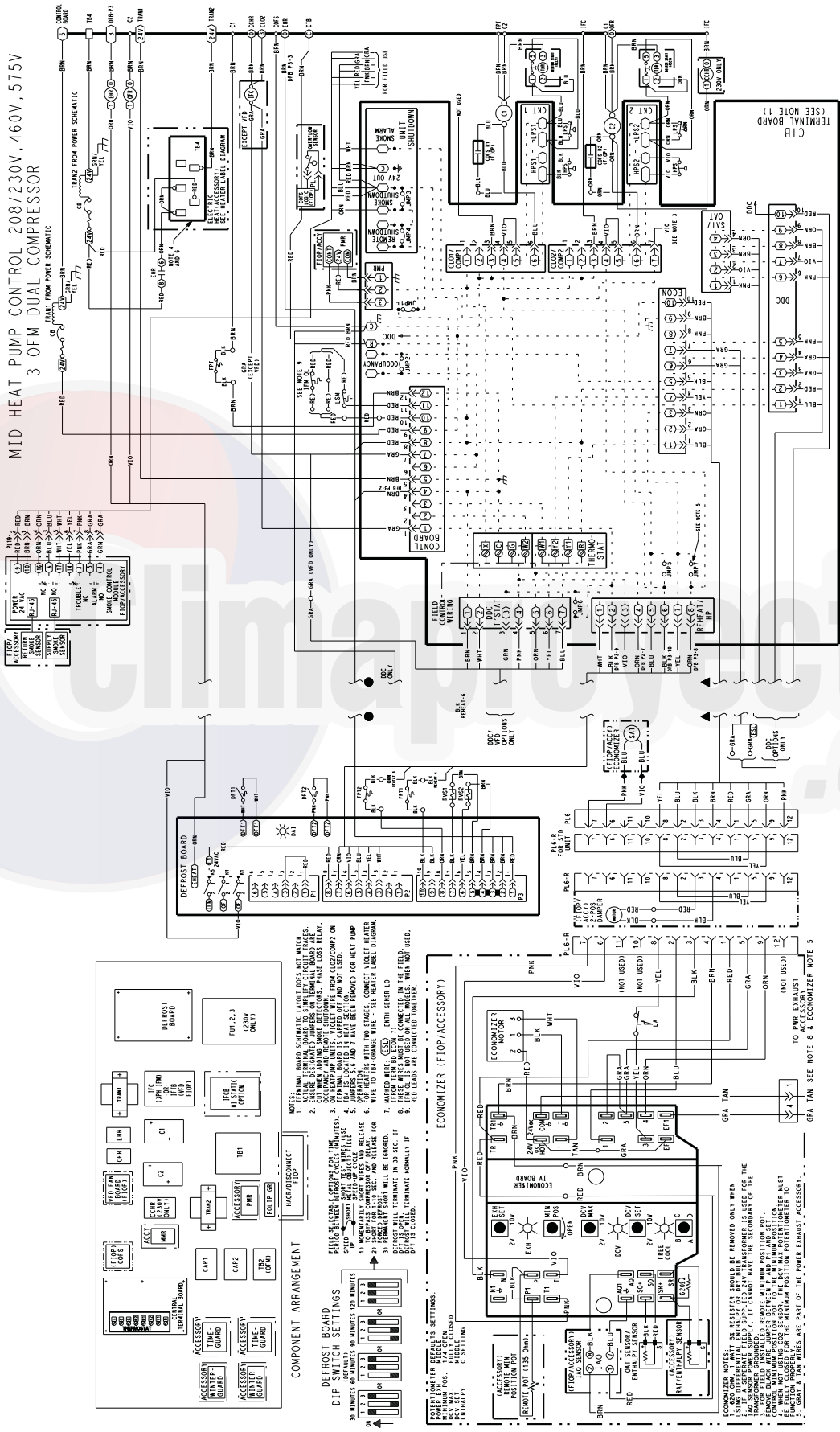

Fig. 62 - 50TCQ D14 Control Wiring Diagram - 208/230-3-60; 460-3-60; 575-3-60

APPENDIX IV. WIRING DIAGRAMS (CONT)

HP POWER 208/230-1-60
3-6TON HP T1

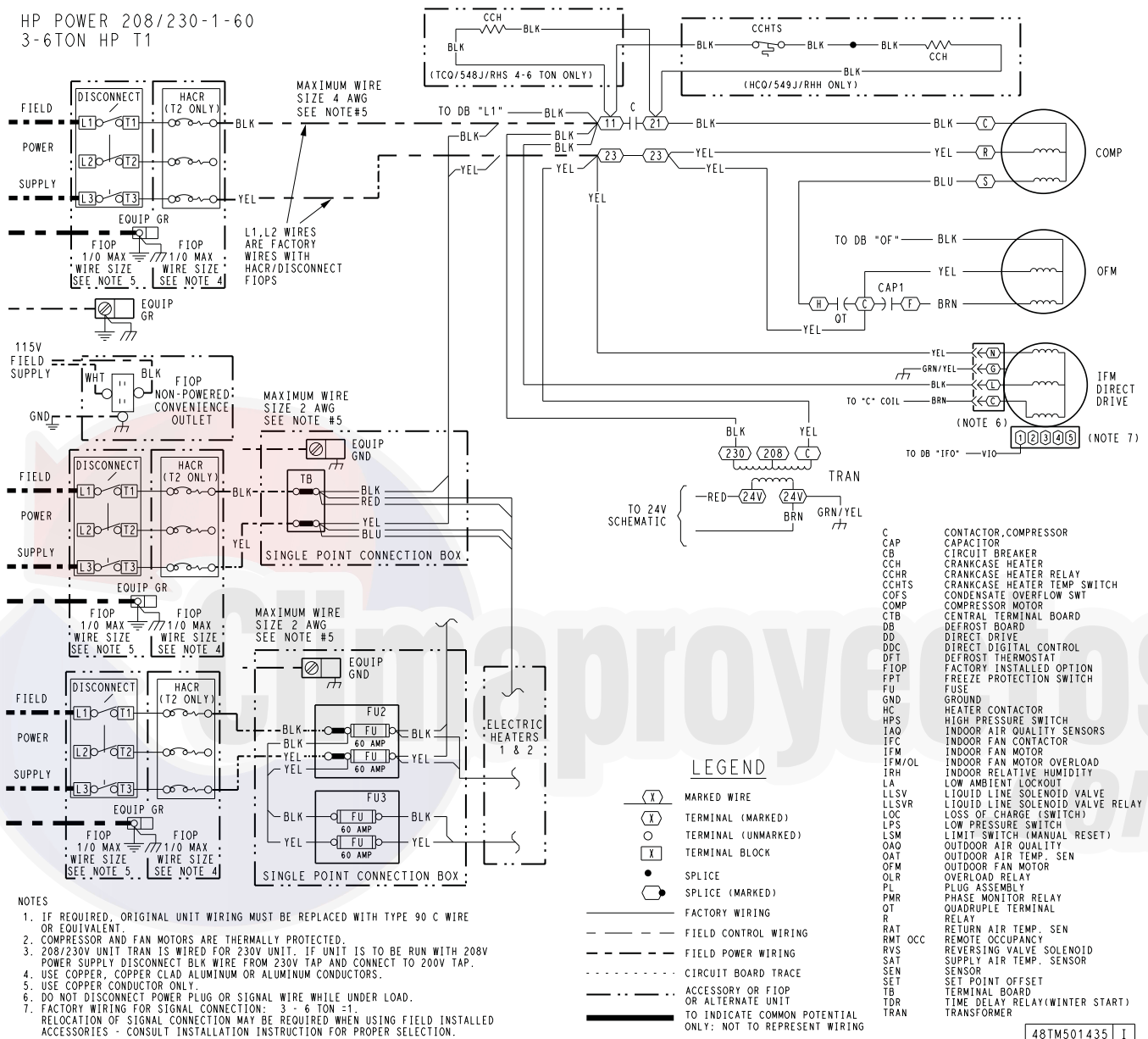

Fig. 63 – 50TCQ A04/A05/A06/A07 Power Wiring Diagram – 208/230-1-60

48TM501435 I

C150243

APPENDIX IV. WIRING DIAGRAMS (CONT)

HP POWER 208/230V 3 PH
3-6TON HP TI

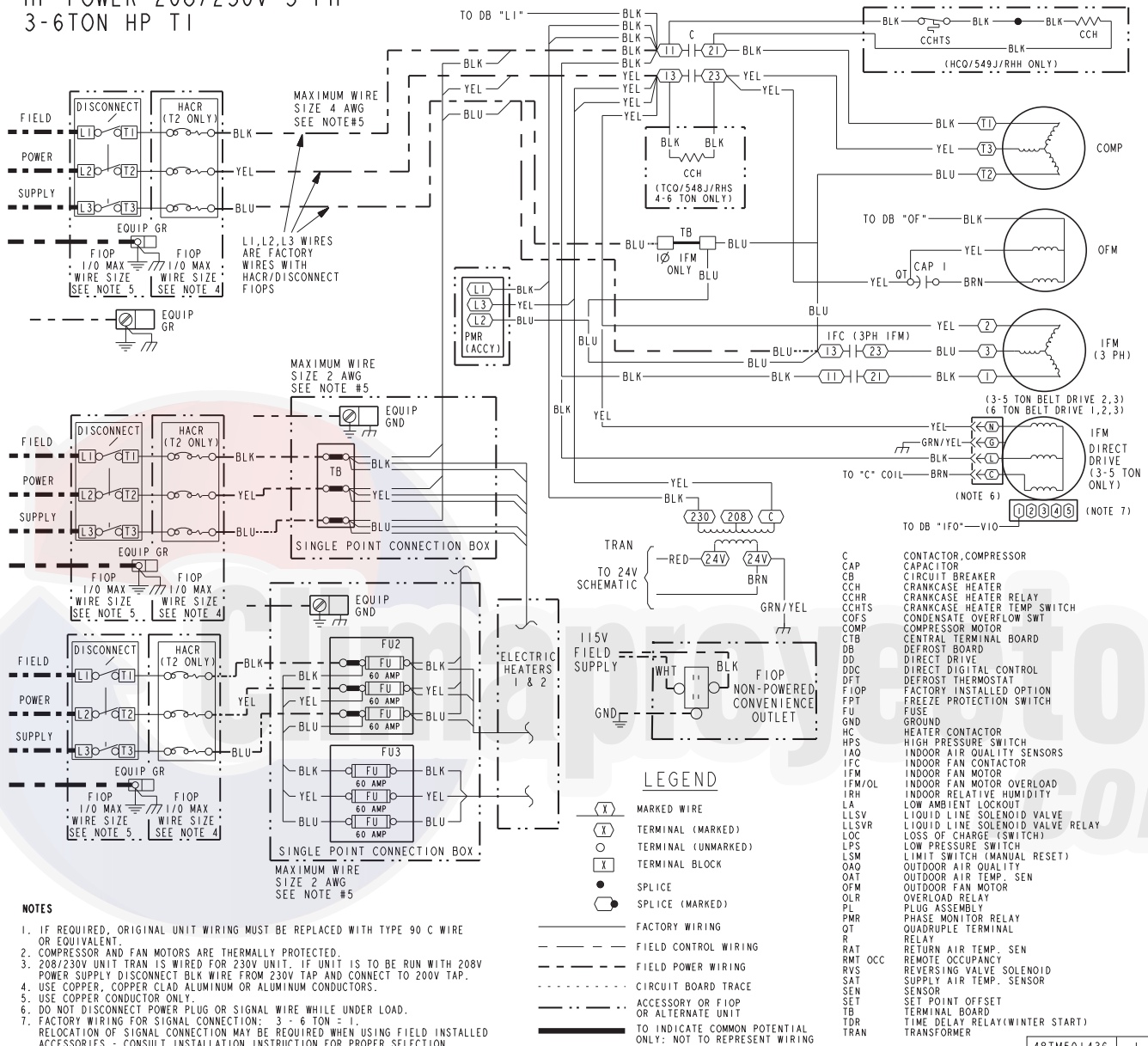

48TM501436 1

C12629

Fig. 64 – 50TCQ A04/A05/A06/A07 Power Wiring Diagram – 208/230-3-60

APPENDIX IV. WIRING DIAGRAMS (CONT)

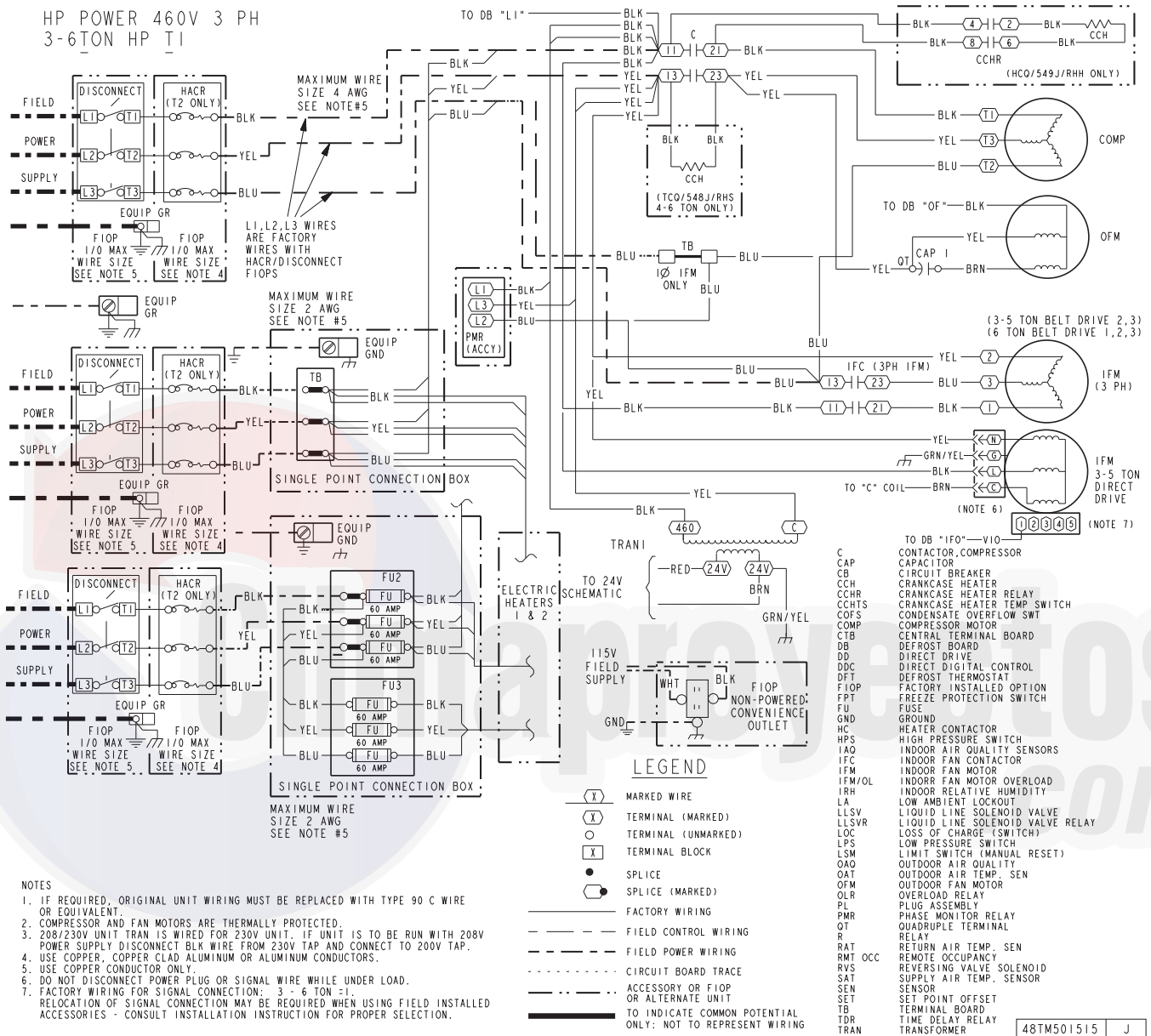

Fig. 65 - 50TCQ A04/A05/A06/A07 Power Wiring Diagram - 460-3-60

48TM501515 J

C12353

APPENDIX IV. WIRING DIAGRAMS (CONT)

HP POWER 575V 3 PH
3-6TON HP T1

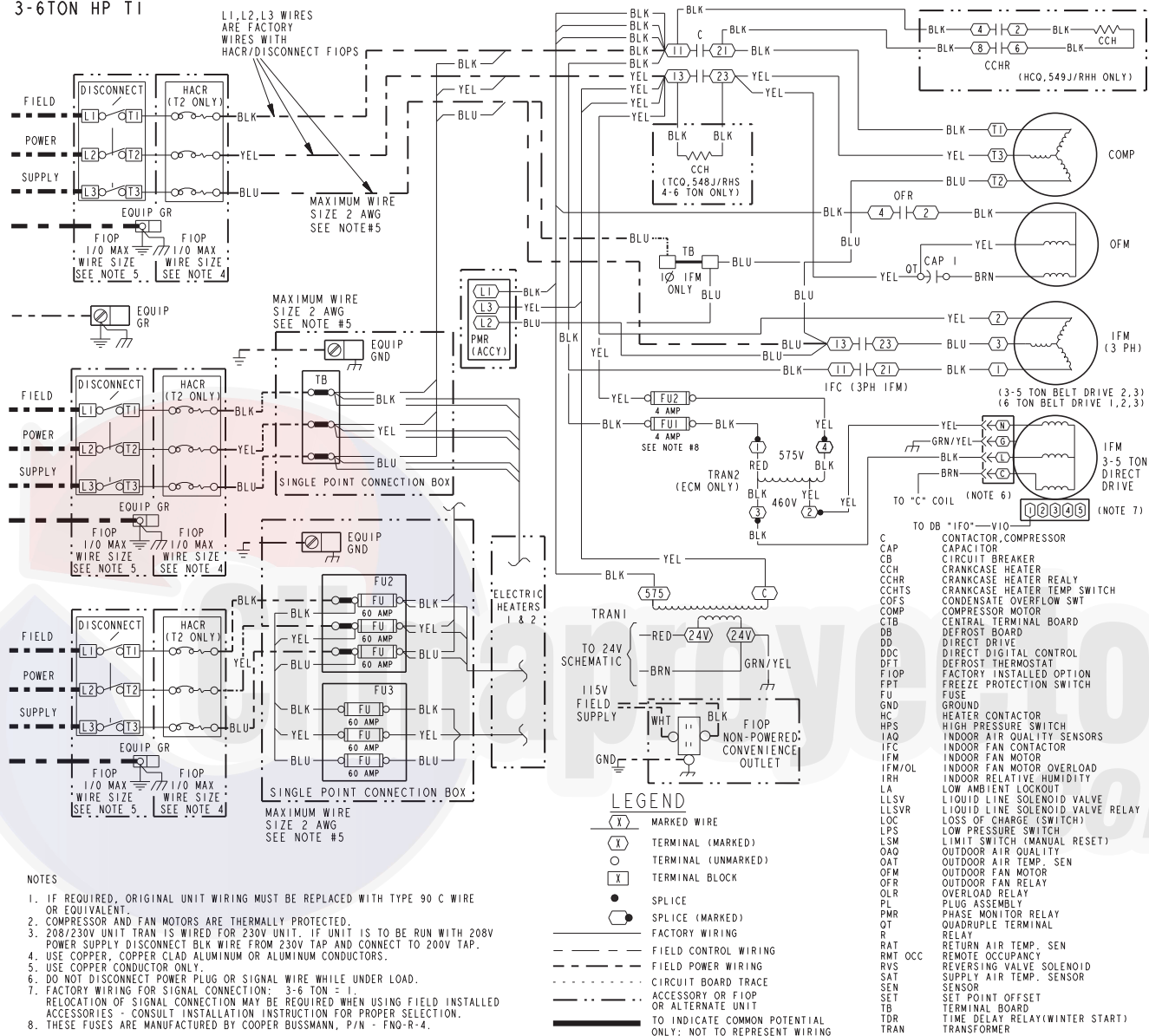

Fig. 66 – 50TCQ A04/A05/A06/A07 Power Wiring Diagram – 575-3-60

48TM501516 J

C12630

APPENDIX IV. WIRING DIAGRAMS (CONT)

HP POWER 208/230V, 460V, 575V 3 PH. 7.5-8.5TON HP (1)COMPR T1

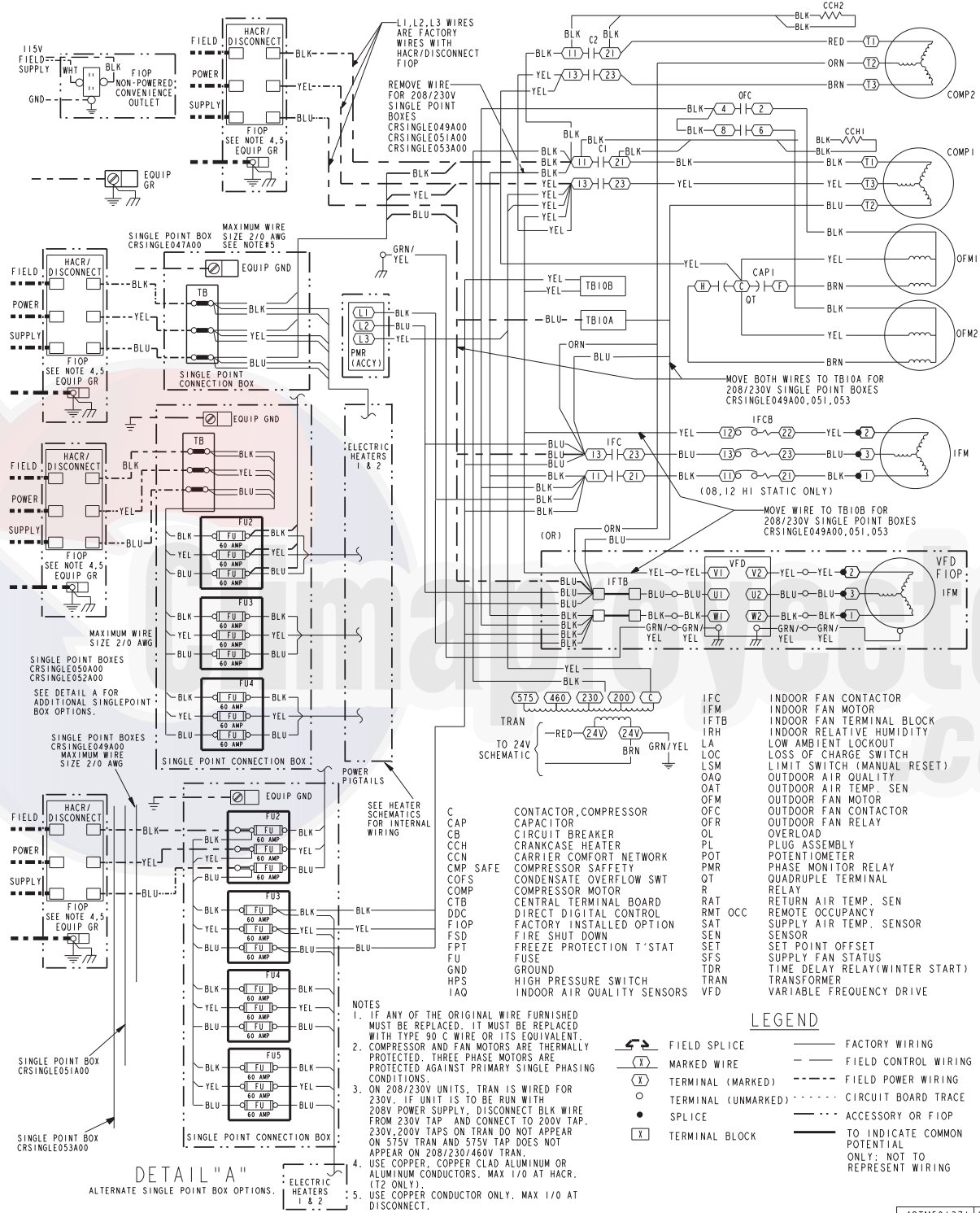

48TM501371 L

C12626

Fig. 67 – 50TCQ D08/D09 Power Wiring Diagram – 208/230–3–60; 460–3–60; 575–3–60

APPENDIX IV. WIRING DIAGRAMS (CONT)

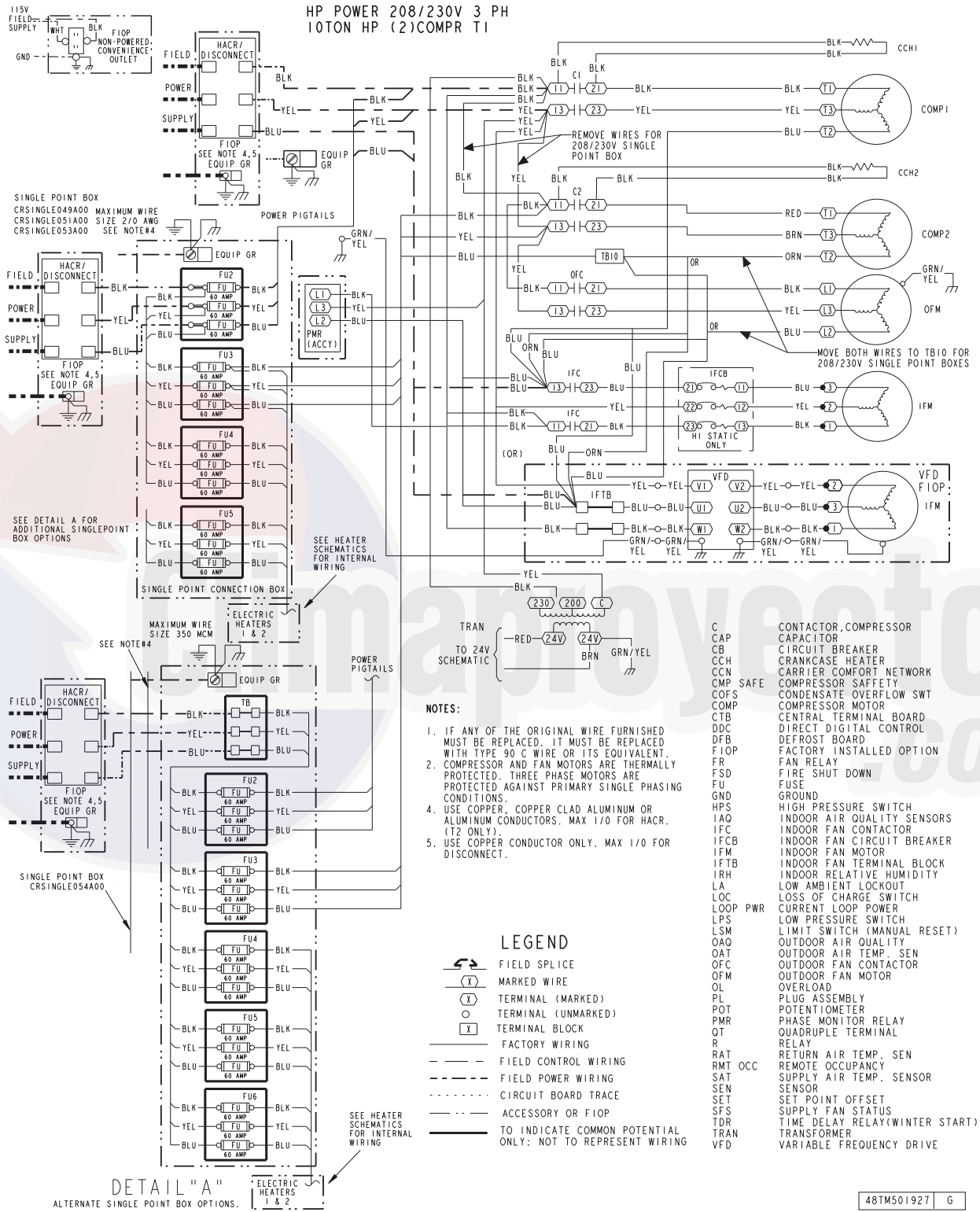

Fig. 68 - 50TCQ D12 Power Wiring Diagram - 208/230-3-60

APPENDIX IV. WIRING DIAGRAMS (CONT)

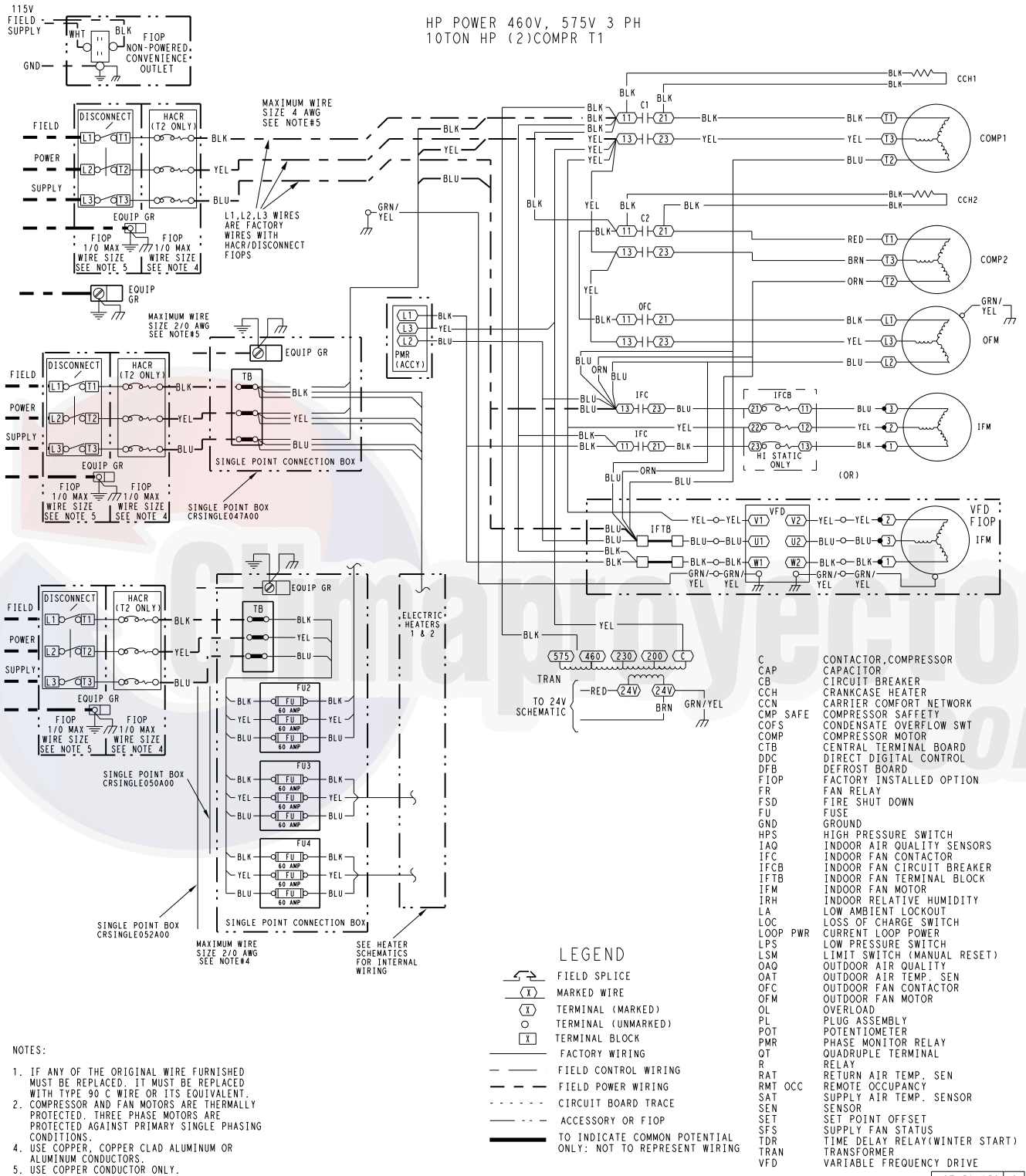

Fig. 69 – 50TCQ D12 Power Wiring Diagram – 460–3–60; 575–3–60

48TM501958 G

C150327

APPENDIX IV. WIRING DIAGRAMS (CONT)

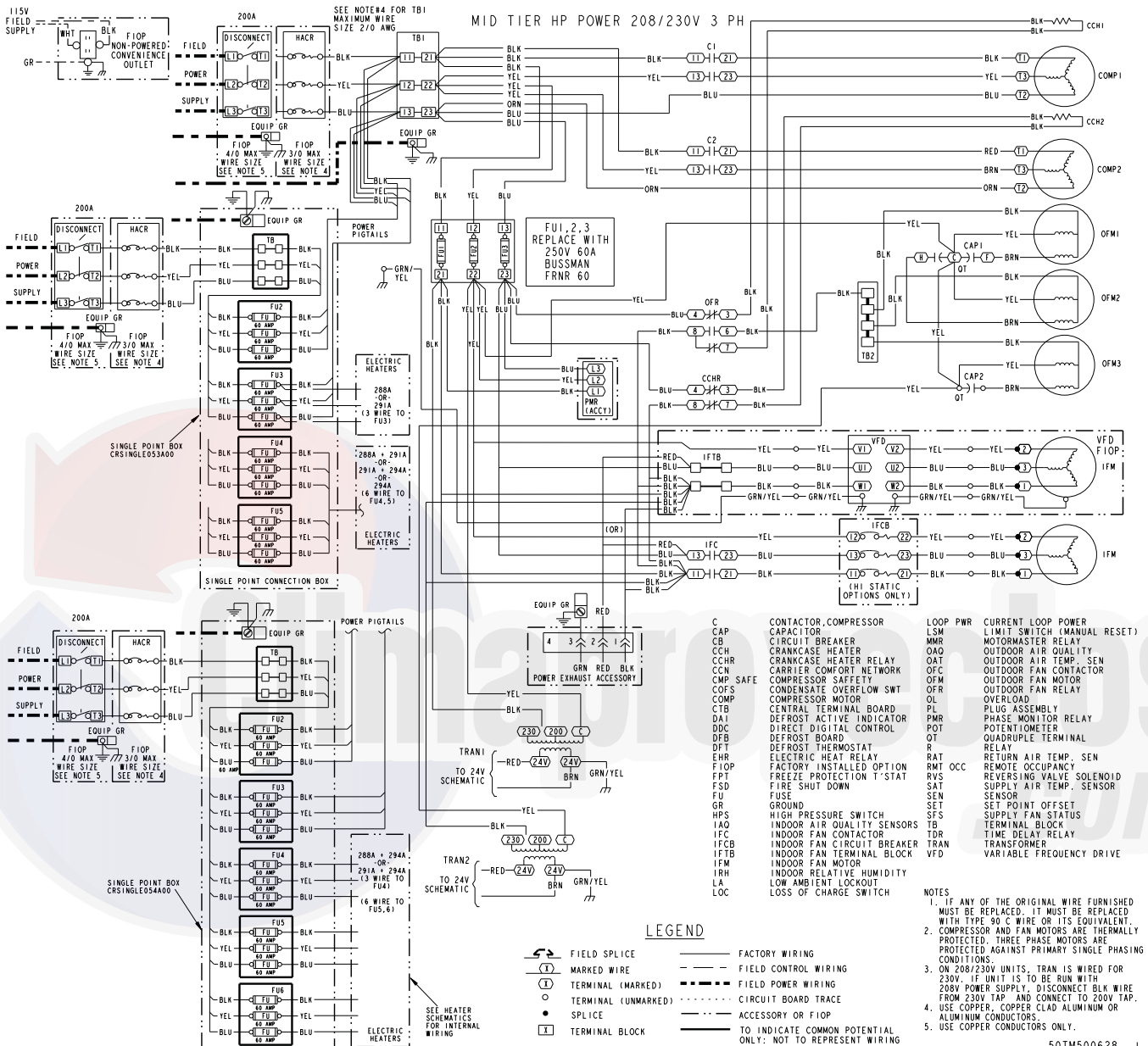

Fig. 70 - 50TCQ D14 Power Wiring Diagram - 208/230-3-60

APPENDIX IV. WIRING DIAGRAMS (CONT)

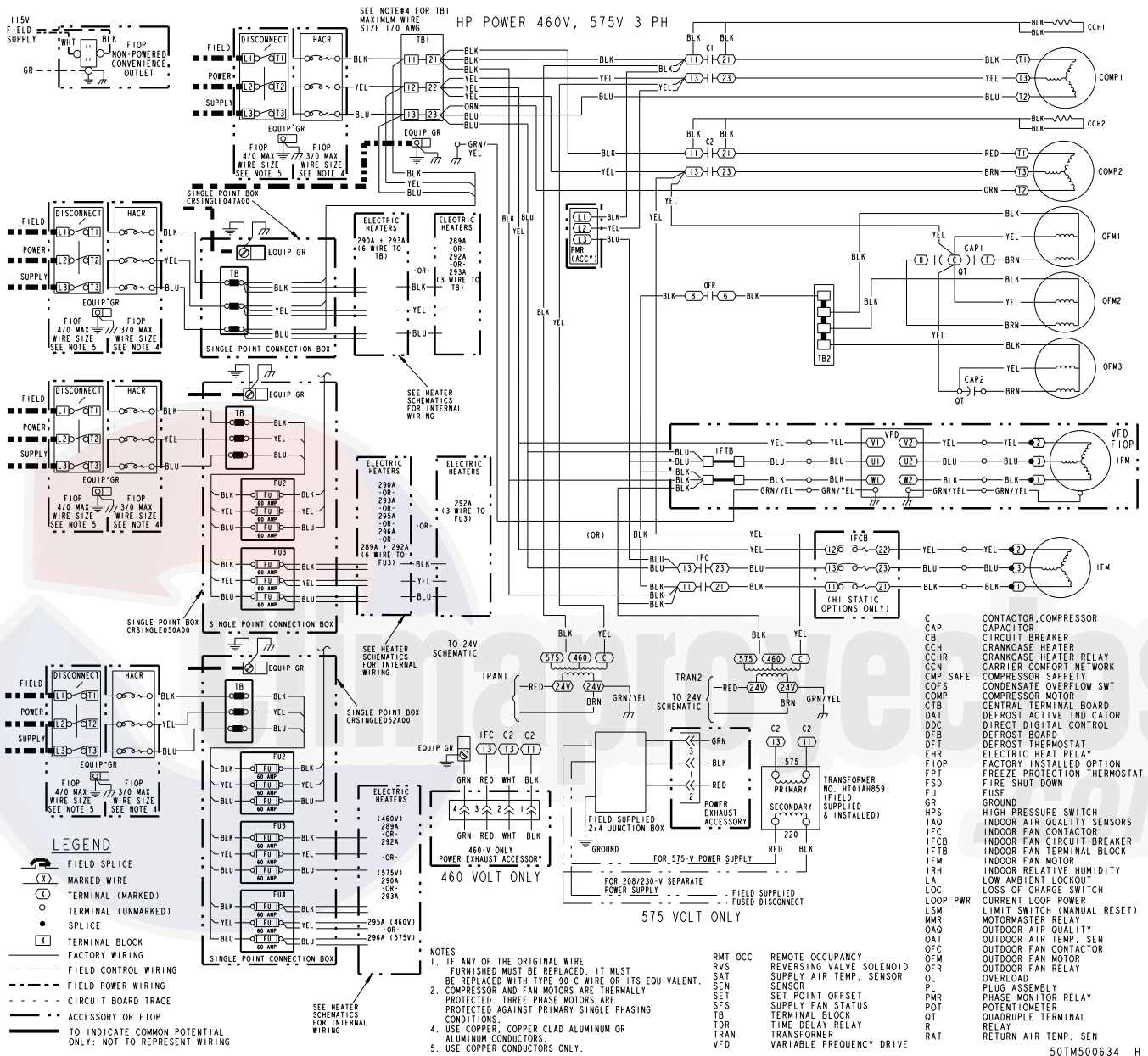
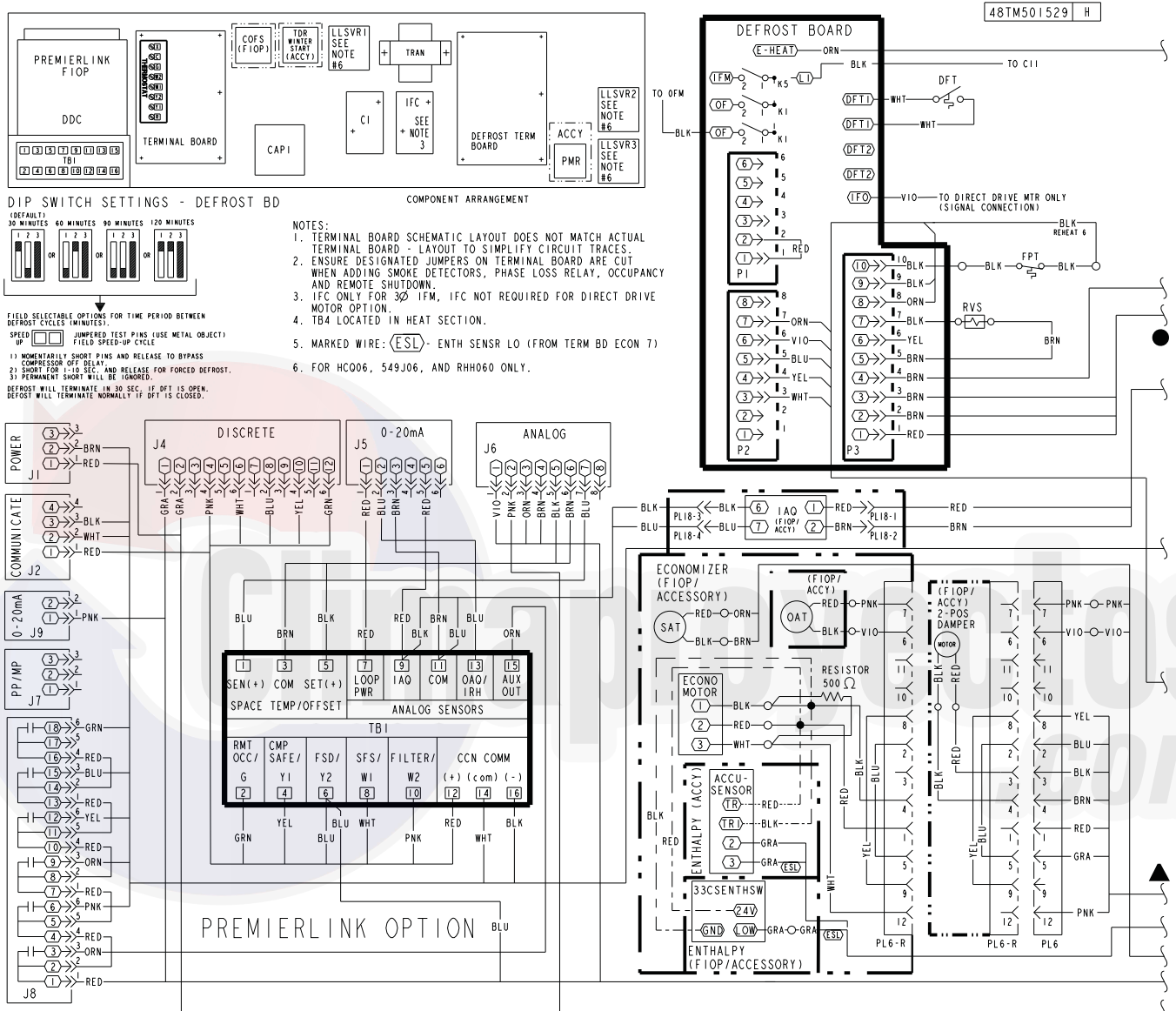

Fig. 71 – 50TCQ D14 Power Wiring Diagram – 460–3–60; 575–3–60

C150431

APPENDIX IV. WIRING DIAGRAMS (CONT)



208/230V
460V

PREMIERLINK LABEL 48TM501529 IS TO OVERLAY CONTROL LABELS 48TM501434,2975. IF ANY CHANGES ARE MADE, ENSURE ALIGNMENT MARKS ARE MAINTAINED.

Fig. 72 – 50TCQ PremierLink Control Diagram

C150432

APPENDIX IV. WIRING DIAGRAMS (CONT)

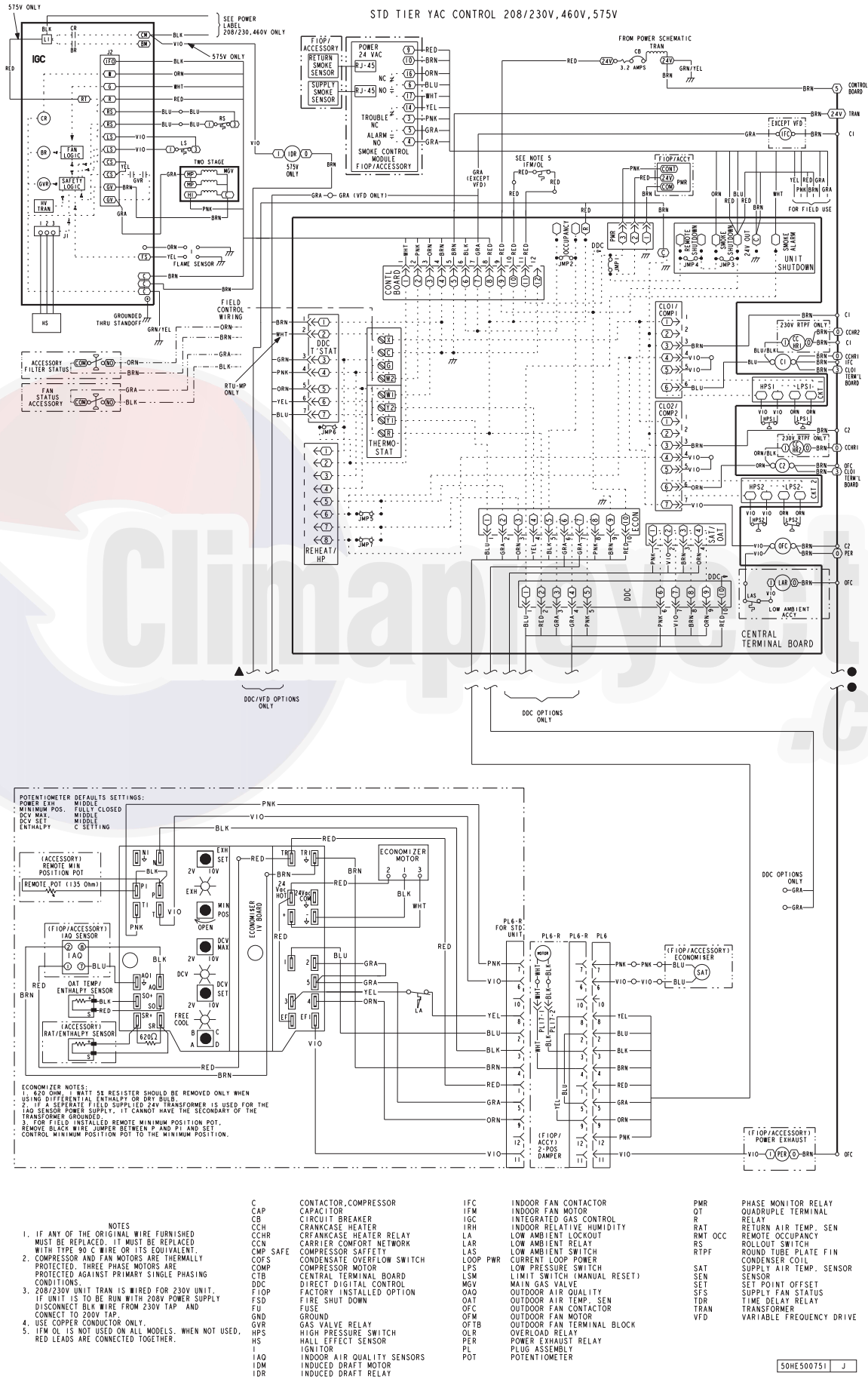

Fig. 73 – 50TCQ RTU–Open Control Diagram

APPENDIX V. MOTORMASTER SENSOR LOCATIONS

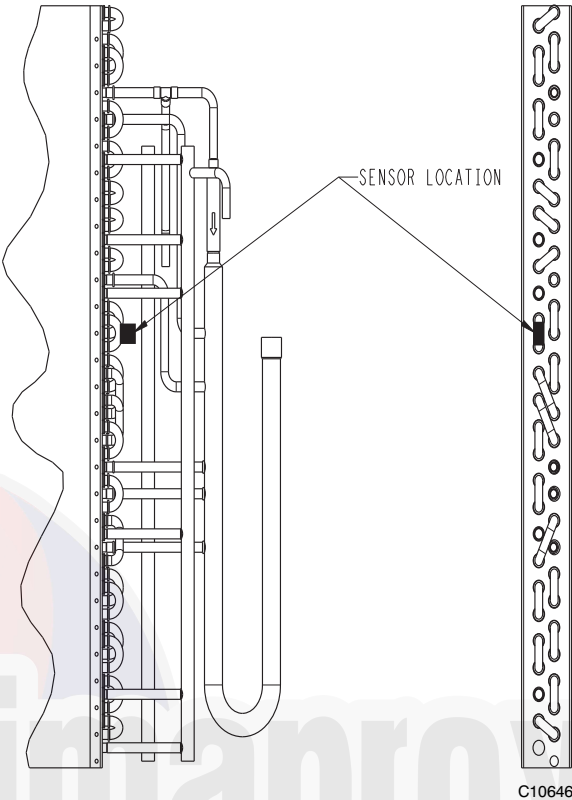

Fig. 74 - 50TCQA04 Outdoor Circuiting

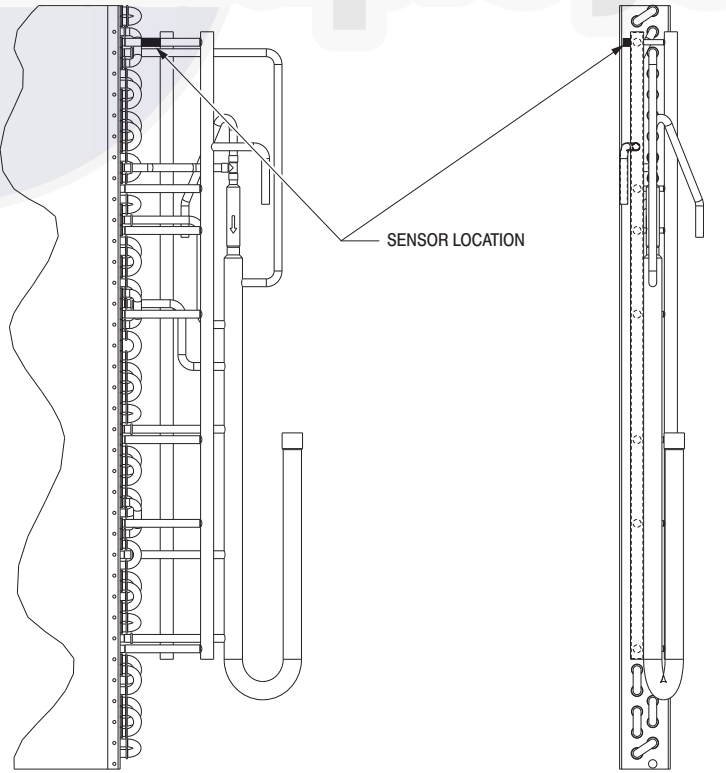

Fig. 75 - 50TCQA05/A06 Outdoor Circuiting

APPENDIX V. MOTORMASTER SENSOR LOCATIONS (CONT)

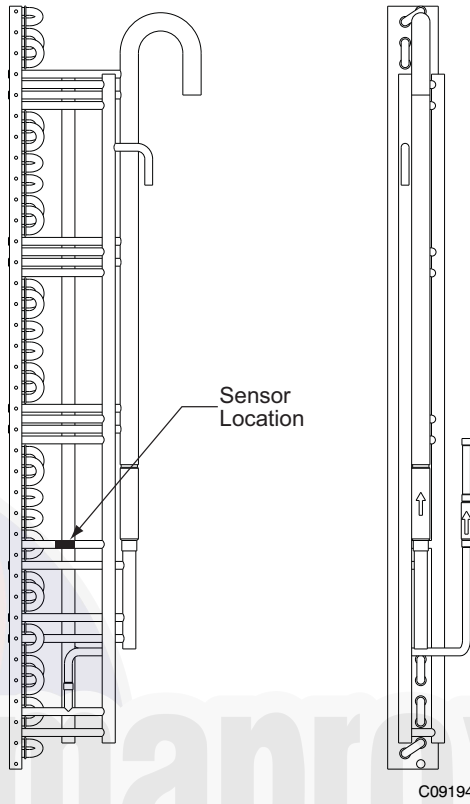

Fig. 76 – 50TCQA07 Outdoor Circuiting

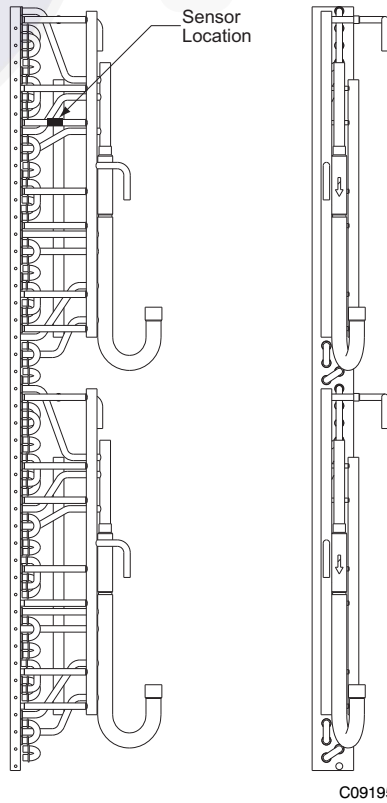
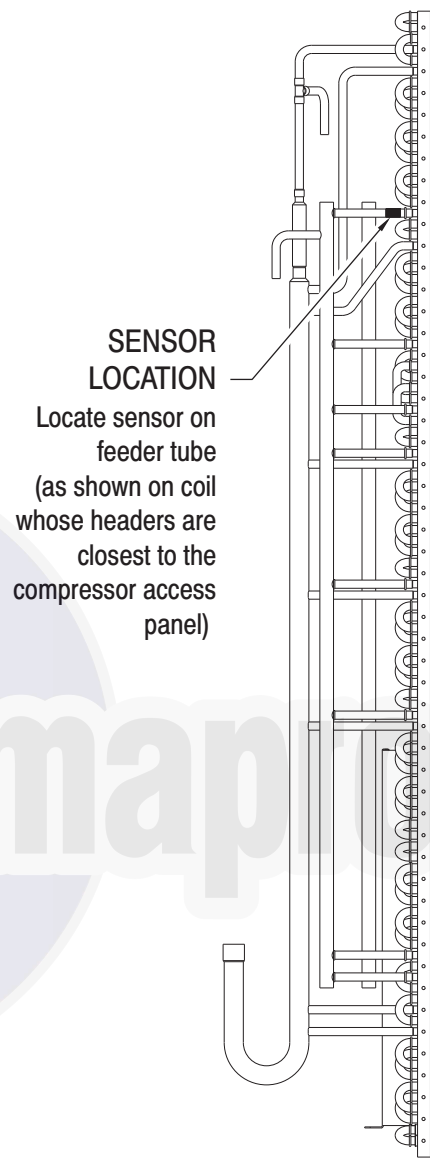

Fig. 77 – 50TCQD08/D09 Outdoor Circuiting

APPENDIX V. MOTORMASTER SENSOR LOCATIONS (CONT)



**SENSOR
LOCATION**
Locate sensor on
feeder tube
(as shown on coil
whose headers are
closest to the
compressor access
panel)

C10939

Fig. 78 - 50TCQD12 Outdoor Circuiting

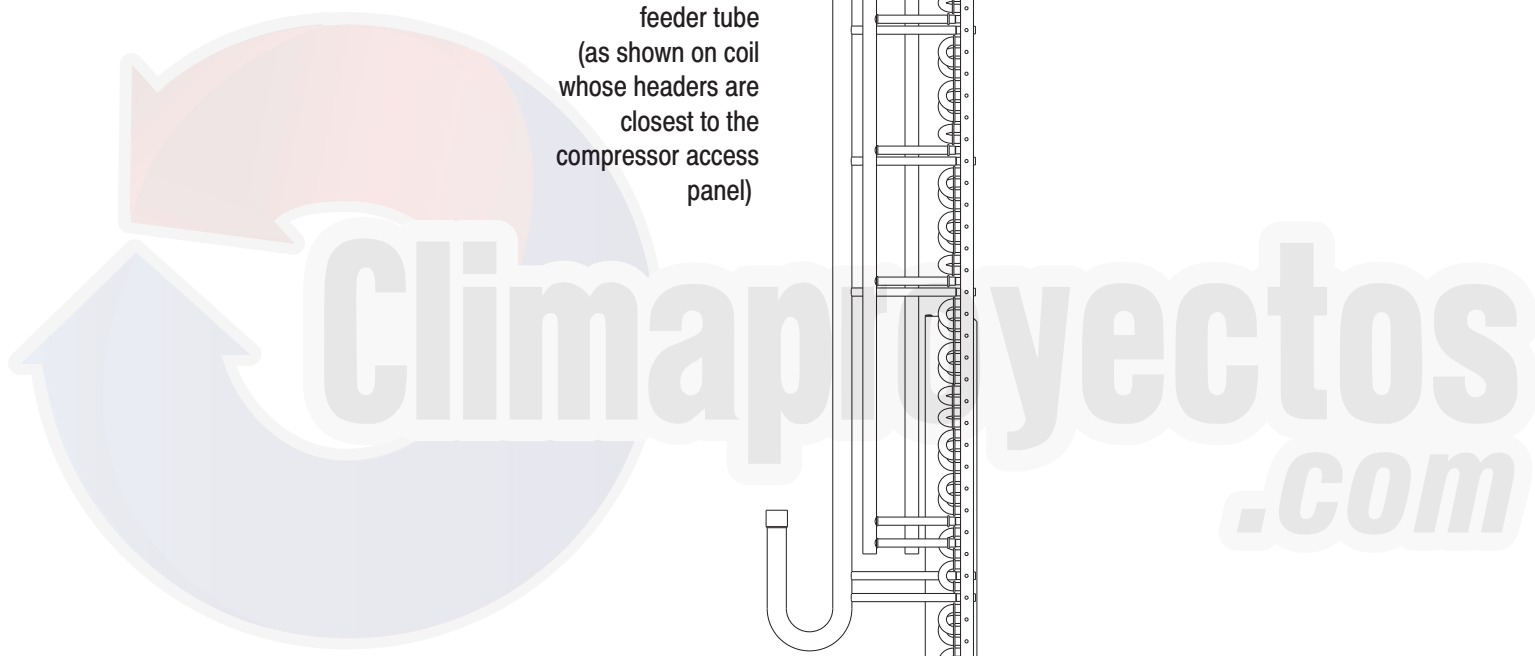

APPENDIX V. MOTORMASTER SENSOR LOCATIONS (CONT)

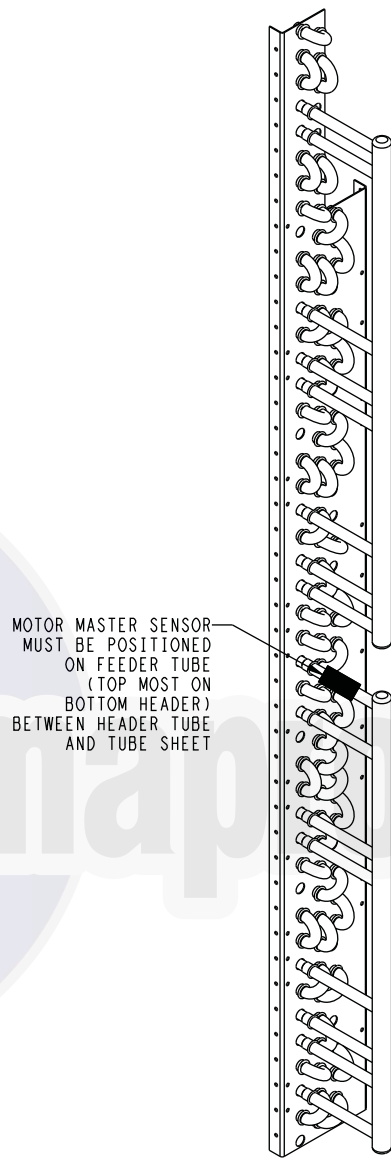

C11096

Fig. 79 - 50TCQD14 Outdoor Circuiting

START-UP CHECKLIST
(Remove and Store in Job File)

I. PRELIMINARY INFORMATION

MODEL NO.: _____

SERIAL NO.: _____

DATE: _____

TECHNICIAN: _____

II. PRE-START-UP (insert checkmark in box as each item is completed)

- VERIFY THAT JOBSITE VOLTAGE AGREES WITH VOLTAGE LISTED ON RATING PLATE
- VERIFY THAT ALL PACKAGING MATERIALS HAVE BEEN REMOVED FROM UNIT
- REMOVE ALL SHIPPING HOLD DOWN BOLTS AND BRACKETS PER INSTALLATION INSTRUCTIONS
- VERIFY THAT CONDENSATE CONNECTION IS INSTALLED PER INSTALLATION INSTRUCTIONS
- CHECK REFRIGERANT PIPING FOR INDICATIONS OF LEAKS; INVESTIGATE AND REPAIR IF NECESSARY
- CHECK ALL ELECTRICAL CONNECTIONS AND TERMINALS FOR TIGHTNESS
- CHECK THAT RETURN (INDOOR) AIR FILTERS ARE CLEAN AND IN PLACE
- VERIFY THAT UNIT INSTALLATION IS LEVEL
- CHECK FAN WHEELS AND PROPELLER FOR LOCATION IN HOUSING/ORIFICE AND SETSCREW TIGHTNESS
- CHECK TO ENSURE THAT ELECTRICAL WIRING IS NOT IN CONTACT WITH REFRIGERANT LINES OR SHARP METAL EDGES
- CHECK PULLEY ALIGNMENT AND BELT TENSION PER INSTALLATION INSTRUCTIONS

III. START-UP

ELECTRICAL

SUPPLY VOLTAGE	L1-L2	_____	L2-L3	_____	L3-L1	_____
CIRCUIT 1 COMPRESSOR AMPS	L1	_____	L2	_____	L3	_____
CIRCUIT 2 COMPRESSOR AMPS	L1	_____	L2	_____	L3	_____
INDOOR-FAN AMPS		_____		_____		_____
OUTDOOR-FAN AMPS	NO. 1	_____	NO. 2	_____	NO. 3	_____

TEMPERATURES

OUTDOOR-AIR TEMPERATURE	_____ DB	_____ WB
RETURN-AIR TEMPERATURE	_____ DB	_____ WB
COOLING SUPPLY AIR	_____ DB	_____ WB

PRESSURES (Cooling Mode)

REFRIGERANT SUCTION, CIRCUIT 1	_____ PSIG	_____ F
REFRIGERANT SUCTION, CIRCUIT 2	_____ PSIG	_____ F
REFRIGERANT DISCHARGE, CIRCUIT 1	_____ PSIG	_____ F
REFRIGERANT DISCHARGE, CIRCUIT 2	_____ PSIG	_____ F

- VERIFY THAT 3-PHASE FAN MOTOR AND BLOWER ARE ROTATING IN CORRECT DIRECTION.
- VERIFY THAT 3-PHASE SCROLL COMPRESSOR IS ROTATING IN THE CORRECT DIRECTION
- VERIFY REFRIGERANT CHARGE USING CHARGING CHARTS

GENERAL

- SET ECONOMIZER MINIMUM VENT AND CHANGEOVER SETTINGS TO MATCH JOB REQUIREMENTS (IF EQUIPPED)

