

50VL-C
Comfort™ 14 SEER Single-Packaged
Air Conditioner System with Puron® (R-410A)
Refrigerant
Single Phase 2-5 Nominal Tons (Sizes 24-60)
Three Phase 3-5 Nominal Tons (Sizes 36-60)



Product Data

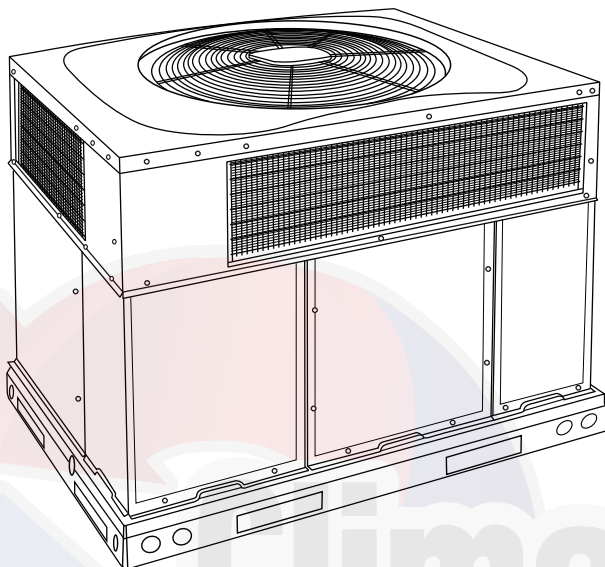

Fig. 1 - Unit 50VL-C

A170030

Single-Packaged Products with Energy-Saving Features and Puron® refrigerant.

- 14.0 SEER / 11.5 EER
- ECM Motor-Standard
- Low Sound Levels
- Dense Wire Condenser Coil Guard-Standard
- Cabinet air leakage of 2.0% or less at .5 in. W.C. when tested in accordance with ASHRAE standard 193. (Low leak FIOP models only.)

FEATURES/BENEFITS

One-piece cooling unit with optional electric heater, low sound levels, easy installation, low maintenance, and dependable performance.

Puron is Carrier's unique refrigerant designed to be environmentally balanced. Puron is an HFC refrigerant which does not contain chlorine that can harm the ozone layer. Puron refrigerant is in service in millions of systems proving highly reliable and is non-ozone depleting.

Easy Installation

Factory-assembled package is a compact, fully self-contained, electric cooling unit that is prewired, pre-piped, and pre-charged for minimum installation expense. These units are available in a variety of standard cooling sizes with voltage options to meet residential and light commercial requirements. Units are lightweight and install easily on a rooftop or at ground level. The high tech composite base eliminates rust problems associated with ground level applications.

Innovative Unit Base Design

On the inside a high-tech composite material will not rust and incorporates a sloped drain pan which improves drainage and helps inhibit mold, algae and bacterial growth. On the outside metal base rails provide added stability as well as easier handling and rigging.

Convertible duct configuration

Unit is designed for use in either downflow or horizontal applications. Each unit is converted from horizontal to downflow and includes horizontal duct covers. Downflow operation is provided in the field to allow vertical ductwork connections. The basepan seals on the bottom openings to ensure a positive seal in the vertical airflow mode.

Efficient operation High-efficiency design offers SEER (Seasonal Energy Efficiency Ratios) of 14.0. (See page 4.)

Durable, dependable components

ECM Motor is standard on all models.

Direct-drive PSC (Permanent Split Capacitor) condenser-fan motors are designed to help reduce energy consumption and provide for cooling operation down to 40°F (4.4°C) outdoor temperature. Motormaster® II low ambient kit is available as a field-installed accessory.

Refrigerant system is designed to provide dependability. Liquid filter driers are used to promote clean, unrestricted operation. Each unit leaves the factory with a full refrigerant charge. Refrigerant service connections make checking operating pressures easier.

High Pressure Switch provide added reliability for the compressor.

Indoor and Outdoor coils are computer-designed for optimum heat transfer and efficiency. The indoor coil is fabricated from copper tube and aluminum fins and is located inside the unit for protection against damage. The outdoor coil is internally mounted on the top tier of the unit.

Low sound ratings ensure a quiet indoor and outdoor environment with sound ratings as low as 73dBA. (See Page 4.)

Easy to service cabinets provide easy 3 panel accessibility to serviceable components during maintenance and installation. The basepan with integrated drain pan provides easy ground level installation with a mounting pad. A nesting feature ensures a positive basepan to roof curb seal when the unit is roof mounted. A convenient 3/4-in. (19.05 mm) wide perimeter flange makes frame mounting on a rooftop easy.

Standard horizontal metal duct covers with insulation come with the unit and cover the horizontal duct openings. These can be left in place if the units are converted to downflow.

Cabinets are constructed of heavyduty, phosphated, zinc-coated prepainted steel capable of withstanding 500 hours in salt spray. Interior surfaces of the evaporator/heat exchanger compartment are insulated with cleanable semi-rigid insulation board, which keeps the conditioned air from being affected by the outdoor ambient temperature and provides improved indoor air quality. (Conforms to American Society of Heating, Refrigeration and Air Conditioning Engineers No. 62P.) The sloped drain pan minimizes standing water in the drain. An external drain is provided.

TABLE OF CONTENTS

FEATURES/BENEFITS	1
MODEL NUMBER NOMENCLATURE	3
AHRI CAPACITIES	4
PHYSICAL DATA	5
OPTIONS AND ACCESSORIES	6
BASE UNIT DIMENSIONS	8-9
ROOF CURB ACCESSORY	10
SELECTION PROCEDURE	11
PERFORMANCE DATA	12-25
TYPICAL PIPING AND WIRING	26
APPLICATION DATA	26
ELECTRICAL DATA	27
TYPICAL WIRING SCHEMATICS	29-34
CONTROLS	35
GUIDE SPECIFICATIONS	36

50VL-C



MODEL NUMBER NOMENCLATURE

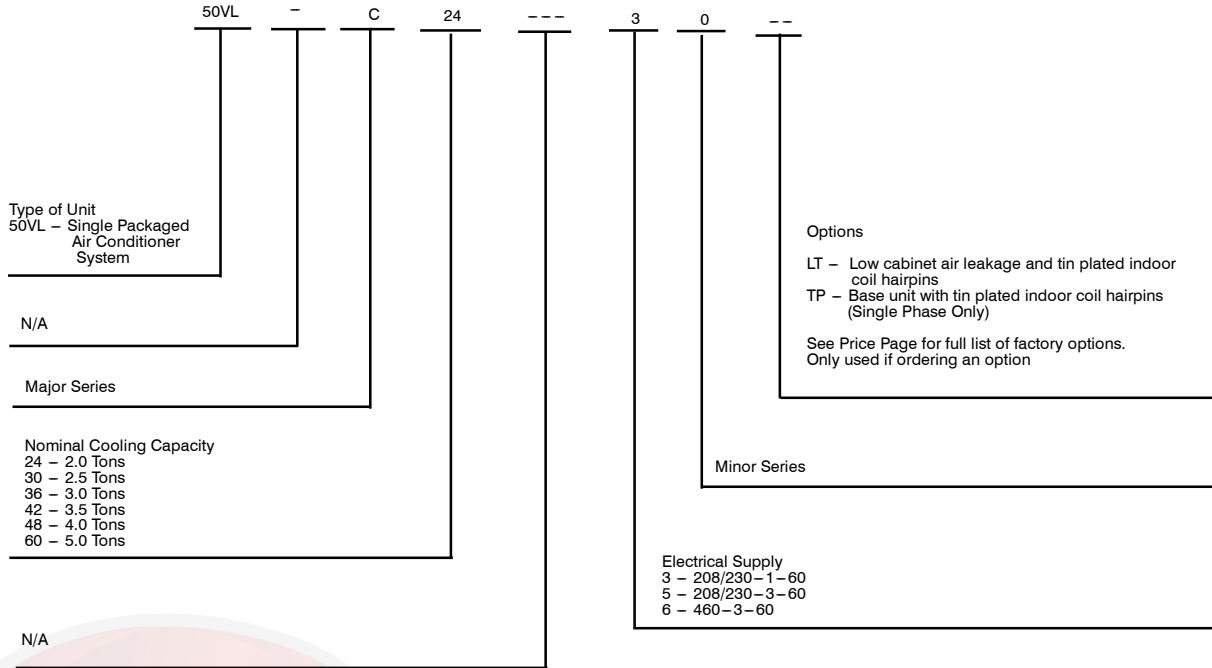

50VL-C

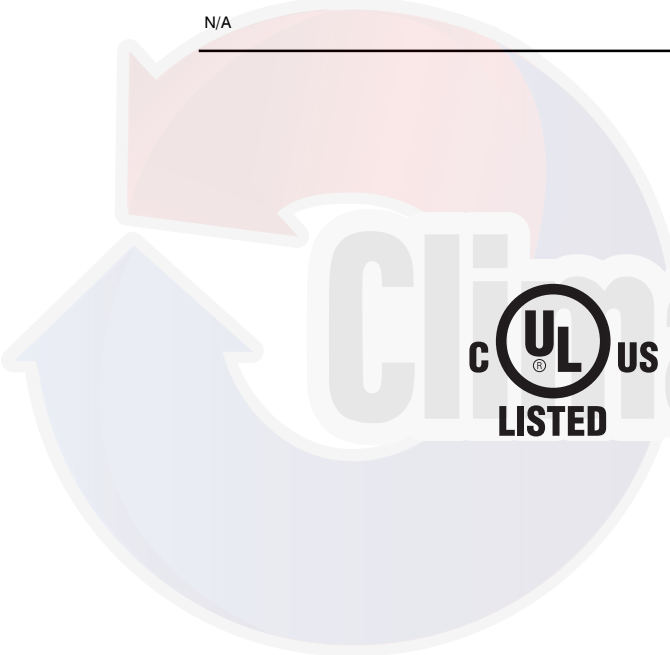

Use of the AHRI Certified TM Mark indicates a manufacturer's participation in the program. For verification of certification for individual products, go to www.ahridirectory.org.

**ASHRAE
COMPLIANT**

climaticobjects.com

AHRI* CAPACITIES

Cooling Capacities and Efficiencies

UNIT SIZE	NOMINAL TONS	STANDARD CFM	COOLING CAPACITY	EER	SEER
24	2	800	23000	11.5	14.0
30	2.5	1000	28600	11.5	14.0
36	3	1150	34800	11.5	14.0
42	3.5	1350	40000	11.5	14.0
48	4	1550	46000	11.5	14.0
60	5	1750	56000	11.5	14.0

LEGEND

dB—Sound Levels (decibels)

db—Dry Bulb

SEER—Seasonal Energy Efficiency Ratio

wb—Wet Bulb

COP—Coefficient of Performance

* Air Conditioning, Heating & Refrigeration Institute.

**At "A" conditions—80°F (26.7°C) indoor db/67°F (19.4°C) indoor wb & 95°F (35°C) outdoor db.

† Rated in accordance with U.S. Government DOE Department of Energy) test procedures and/or AHRI Standards 210/240.

Notes:

1. Ratings are net values, reflecting the effects of circulating fan heat.

Ratings are based on:

Cooling Standard: 80°F (26.7°C) db, 67°F wb (19.4°C) indoor entering—air temperature and 95°F db (35°C) outdoor entering—air temperature.

2. Before purchasing this appliance, read important energy cost and efficiency information available from your retailer.

50VL-C

A-WEIGHTED SOUND POWER LEVEL (dBA)

UNIT SIZE	SOUND RATING	TYPICAL OCTAVE BAND SPECTRUM (dBA without tone adjustment)						
		125	250	500	1000	2000	4000	8000
24	73	54.3	61.3	55.2	54.8	57.1	53.6	43.1
30	73	58.1	59.4	61.2	64.1	59.2	56.8	50.9
36	74	58.7	62.8	65.7	67.8	63.7	58.9	51.7
42	74	54.4	59.0	61.2	62.1	58.9	53.5	46.7
48	73	57.1	57.6	60.5	62.7	58.2	56.4	50.7
60	76	64.4	59.7	59.6	60.6	59.8	55.5	47.8

NOTE: Tested in accordance with AHRI Standard 270—1995 (not listed in AHRI).

PHYSICAL DATA

UNIT SIZE	24	30	36	42	48	60
NOMINAL CAPACITY (ton)	2	2-1/2	3	3-1/2	4	5
SHIPPING WEIGHT lb.	329	361	390	455	480	497
SHIPPING WEIGHT (kg)	149	164	177	206	218	225
COMPRESSORS	Rotary	Reciprocating	Scroll			
Quantity	1					
REFRIGERANT (R-410A)						
Quantity lb	5.3	5.5	8.2	6.2	9.2	9.8
Quantity (kg)	2.4	2.5	3.7	2.8	4.2	4.5
REFRIGERANT METERING DEVICE	Orifice		TXV	Orifice		
ORIFICE ID in./mm	.059 / 1.5	.061 / 1.55	N/A	.073 / 1.85	.080 / 2.03	.084 / 2.14
OUTDOOR COIL						
Rows...Fins/in.	1...21	1...21	1...21	1...21	1...21	1...21
Face Area (sq ft)	11.9	13.6	18.8	13.6	21.4	23.3
OUTDOOR FAN						
Nominal Cfm	2500	2700	3200	3600	3600	4200
Diameter in.	24	24	24	26	26	26
Diameter (mm)	609.6	609.6	609.6	660.4	660.4	660.4
Motor Hp (Rpm)	1/12 (810)	1/10 (810)	1/5 (810)	1/5 (810)	1/5 (810)	1/5 (810)
INDOOR COIL						
Rows...Fins/in.	3...17	3...17	3...17	3...17	3...17	3...17
Face Area (sq ft)	3.7	3.7	3.7	4.7	4.7	5.6
INDOOR BLOWER						
Nominal Cooling Airflow (Cfm)	800	1000	1150	1350	1550	1750
Size in.	10x10	10x10	11x10	11x10	11x10	11x10
Size (mm.)	254x254	254x254	279.4x254	279.4x254	279.4x254	279.4x254
Motor HP (RPM)	1/2 (1050)	1/2 (1050)	3/4 (1000)	1/2 (1075)	1.0 (1075)	1.0 (1040)
HIGH-PRESSURE SWITCH (psig) Cut-out Reset (Auto)	650 +/- 15 420 +/- 25					
LOSS-OF-CHARGE / LOW-PRESSURE SWITCH (psig) cut-out Reset (auto)	20 +/- 5 45 +/- 10	N/A				
RETURN-AIR FILTERS†‡				1 each 24x14x1 610x356x25 24x15x1 610x406x25		1 each 24x16x1 610x406x25 24x18x1 610x457x25
Throwaway Size in.	2 each 20x12x1					
Throwaway Size (mm)	508x305x25					

† Required filter sizes shown are based on the larger of the AHRI (Air Conditioning Heating and Refrigeration Institute) rated cooling airflow or the heating airflow velocity of 300 to 350 ft/minute for throwaway type or 450 ft/minute for high-capacity type. Air filter pressure drop for non-standard filters must not exceed 0.08 in. W.C.

‡ If using accessory filter rack refer to the filter rack installation instructions for correct filter sizes and quantity.

Electric Heat Pressure Drop Tables (IN. W.C.) Small Cabinet: 24-36

STATIC	CFM											
	500	600	700	800	900	1000	1100	1200	1300	1400	1500	1600
5 kW	0.00	0.00	0.00	0.00	0.00	0.00	0.00	0.00	0.02	0.04	0.06	0.07
10 kW	0.00	0.00	0.00	0.00	0.00	0.02	0.04	0.06	0.07	0.09	0.10	0.11
15 kW	0.00	0.00	0.00	0.02	0.04	0.06	0.08	0.10	0.12	0.14	0.16	0.18
20 kW	0.00	0.00	0.02	0.04	0.06	0.08	0.09	0.11	0.13	0.15	0.17	0.19

Large Cabinet: 42-60

STATIC	CFM														
	1100	1200	1300	1400	1500	1600	1700	1800	1900	2000	2100	2200	2300	2400	2500
5 kW	0.00	0.00	0.00	0.01	0.02	0.03	0.04	0.05	0.06	0.07	0.08	0.09	0.10	0.11	0.12
10 kW	0.00	0.00	0.01	0.02	0.03	0.04	0.05	0.06	0.07	0.08	0.09	0.10	0.11	0.12	0.13
15 kW	0.00	0.02	0.03	0.04	0.05	0.06	0.07	0.08	0.09	0.10	0.11	0.12	0.13	0.14	0.15
20 kW	0.02	0.03	0.04	0.05	0.06	0.07	0.08	0.09	0.10	0.11	0.12	0.13	0.14	0.15	0.16

50VL-C

OPTIONS AND ACCESSORIES

ITEM	DESCRIPTION	FACTORY INSTALLED OPTION	FIELD INSTALLED ACCESSORY
Coil Options	Base unit with tin plated indoor coil hairpins	X	
Compressor Start Kit	Compressor Start Kit assists compressor start-up by providing additional starting torque on sing phase units only.		X
Corporate Thermostats	Thermostats provide control for the system heating and cooling functions.		X
Crankcase Heater	Crankcase Heater provides anti-floodback protection for low-load cooling applications.		X*
Economizer	Horizontal Economizer with solid state controls and barometric relief dampers includes filter racks and provide outdoor air during cooling and reduce compressor operation.		X
	Vertical Economizer with solid state controls and barometric relief dampers includes filter racks and provide outdoor air during cooling and reduce compressor operation.		X
Electric Heaters	Electric Heat Supplement		X
Filter Rack	Filter Rack features easy installation, serviceability, and high-filtering performance for vertical applications. Includes 1-in. filter.		X
Flat Roof Curb	14-in. (356 mm) Flat Roof Curb is available for roof mounted applications.		X
Low Ambient Kit	Low Ambient Kit (Motormaster II Control) allows the use of mechanical cooling down to outdoor temperatures as low as 0°F (-18°C) when properly installed.		X
Manual Outside Air Damper	Manual Outside Air Damper includes hood and filter rack with adjustable damper blade for up to 25% outdoor air.		X
Square-to-Round Duct Transition Kit	Square-to-Round Duct Transition Kit enable 24-48 size units to be fitted to 14 in (356 mm). round ductwork.		X
Time Guard II	Automatically prevents the compressor from restarting for at least 4 minutes and 45 seconds after shutdown of the compressor. Not required when a corporate programmable thermostat is applied or with a RTU-MP control.		X
Dual Point Electric Heaters	Allows you to power the electric heater and unit contactor separately by having two individual field power supply circuits connected respectively.		X
Low Cabinet Air Leakage	Cabinet air leakage of 2.0% or less at .5 in. W.C. when tested in accordance with ASHRAE standard 193.	X	
Louver Metal Outdoor Coil Grilles	Louver Metal Outdoor Coil Grilles provide hail and vandalism protection.		X
Low Pressure Switch Kit	This kit is designed for use when a low pressure control is desired.		X

*Refer to Price Page for application detail.

Electric Heaters

CATALOG ORDERING NO.	NOMINAL CAPACITY (kW)	FUSE QTY	USED WITH SIZES					
			24	30	36	42	48	60
ELECTRIC HEATERS (208/230 — SINGLE PHASE — 60 Hz)								
CPHEATER052A0*	5.0	—	X	X	X	X	X	X
CPHEATER064A0*	5.0	4	X	X	X	X	X	X
CPHEATER069A0*	7.2	—	X	X	X	X	X	X
CPHEATER070A0*	7.2	4	X	X	X	X	X	X
CPHEATER065A0*	10.0	—	X	X	X	X		
CPHEATER050A0*	10.0	4	X	X	X	X	X	X
CPHEATER051A0*	15.0	4		X	X	X		
CPHEATER066A0*	15.0	6		X	X	X	X	X
CPHEATER053A0*	20.0	6				X		
CPHEATER054A0*	20.0	6				X	X	X
ELECTRIC HEATERS (208/230 — THREE PHASE — 60 Hz)								
CPHEATER055A0*	5.0	—			X	X	X	X
CPHEATER056A0*	10.0	—			X	X	X	X
CPHEATER068A0*	10.0	6			X	X	X	X
CPHEATER057A0*	15.0	—			X	X	X	X
CPHEATER058A0*	15.0	6			X	X	X	X
CPHEATER059A0*	20.0	6					X	X
ELECTRIC HEATERS (460 — THREE PHASE — 60 Hz)								
CPHEATER061A0*	10.0	—			X	X	X	X
CPHEATER062A0*	15.0	—			X	X	X	X
CPHEATER063A0*	20.0	—				X	X	X

NOTE: Electric heaters are rated at 240v. Refer to Multiplication Factors table for other voltages.

X = Approved combinations.

Minimum Airflow for Safe Electric Heater Operation (CFM)

SIZE	24	30	36	42	48	60
Cfm	800	1000	1200	1400	1600	1750

ECONOMIZER

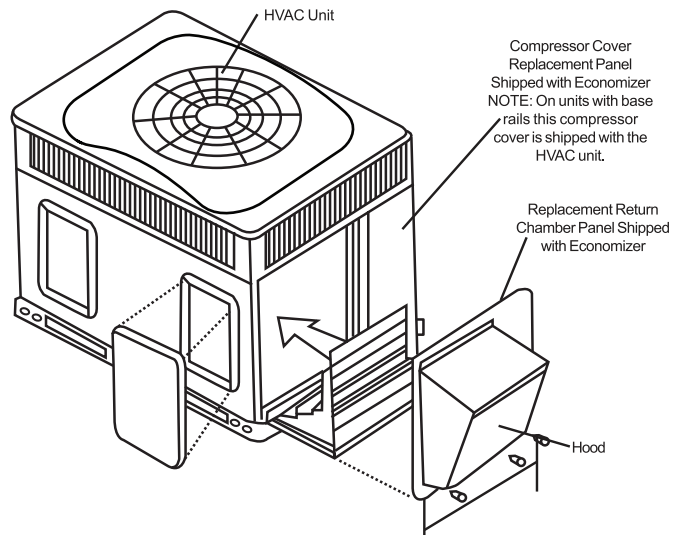
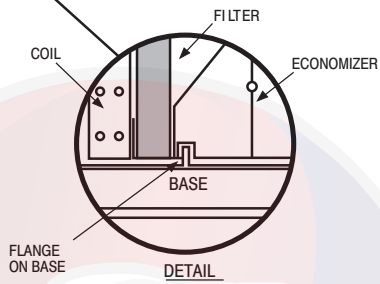
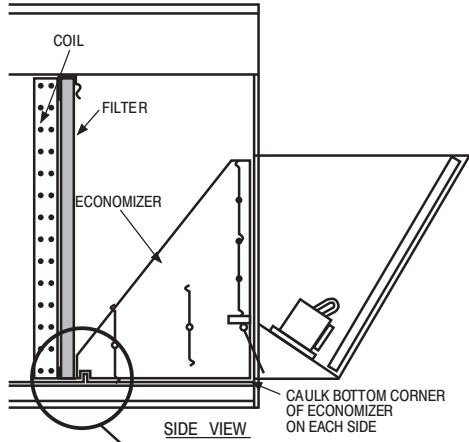

Vertical Economizer

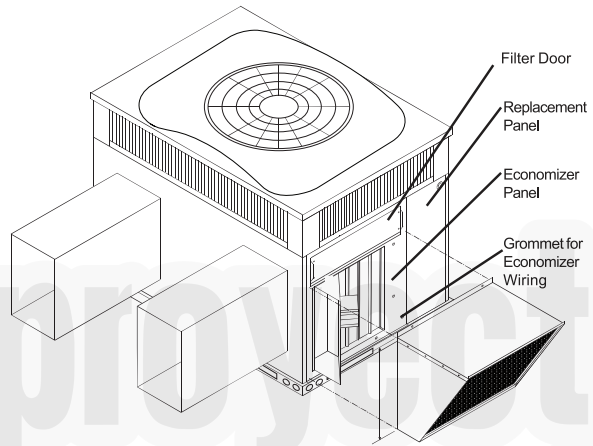

Horizontal Economizer

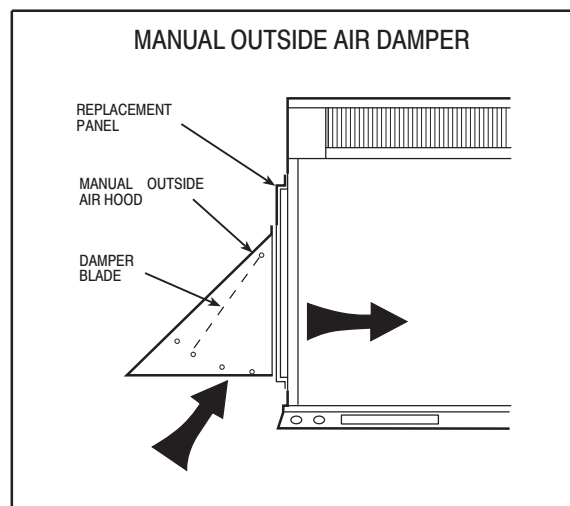
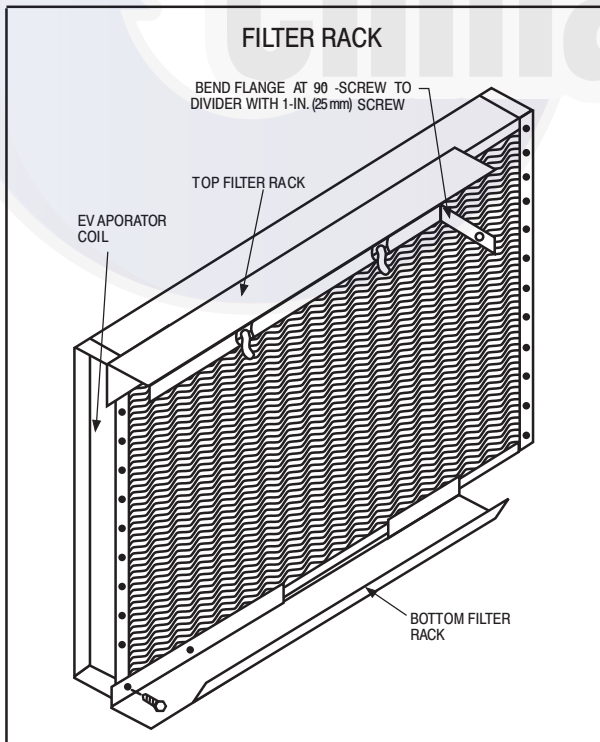

A09375

50VL-C

UNIT DIMENSIONS - 24-36

50VL-C

UNIT	ELECTRICAL CHARACTERISTICS	UNIT WT.		UNIT HEIGHT IN/MM		CENTER OF GRAVITY IN/MM					
		LB	KG	"A"	"A"	X	Y	Z			
50VL-C24---30	208/230-1-60	304	138.0	43-3/4	1111	20-1/2	520.7	15-3/4	400.1	16-5/8	422.3
50VL-C30---30	208/230-1-60	336	152.0	45-3/4	1162	20-1/2	520.7	15-3/4	400.1	16-5/8	422.3
50VL-C36---30	208/230-1-60, 208/230-3-60, 480-3-60	349	158.0	51-3/4	1315	20-1/2	520.7	15-3/4	400.1	17-3/8	441.3

UNIT	VOLTAGE	CORNER WEIGHT LB/KG			
		"1"	"2"	"3"	"4"
24	208/230	45.6	20.7	60.8	27.6
30	208/230	50.4	22.9	67.2	30.5
36	208/230/480	52.4	23.7	69.8	31.7

REQUIRED CLEARANCES TO COMBUSTIBLE MATL

	INCHES (MM)
TOP OF UNIT	14 [355.6]
DUCT SIDE OF UNIT	14 [355.6]
SIDE OPPOSITE DUCTS	14 [355.6]
BOTTOM OF UNIT	0 [0.0]
ELECTRICAL PANEL	36 [914.4]

NEC REQUIRED CLEARANCES

	INCHES (MM)
BETWEEN UNITS, POWER ENTRY SIDE	42 [1066.8]
UNIT AND UNGROUND SURFACES, POWER ENTRY SIDE	36 [914.0]
UNIT AND BLOCK OR CONCRETE WALLS AND OTHER GROUND SURFACES, POWER ENTRY SIDE	42 [1066.8]

REQUIRED CLEARANCE FOR OPERATION AND SERVICING

	INCHES (MM)
EVAP. COIL ACCESS SIDE	36 [914.0]
POWER ENTRY SIDE (EXCEPT FOR NEC REQUIREMENTS)	42 [1066.8]
UNIT TOP	48 [1219.2]
SIDE OPPOSITE DUCTS	36 [914.0]
DUCT PANEL	12 [304.8]

*MINIMUM DISTANCES: IF UNIT IS PLACED LESS THAN 12 [304.8] FROM WALL SYSTEM, THEN SYSTEM PERFORMANCE MAY BE COMPROMISED.

DIMENSIONS IN [] ARE IN MILLIMETERS

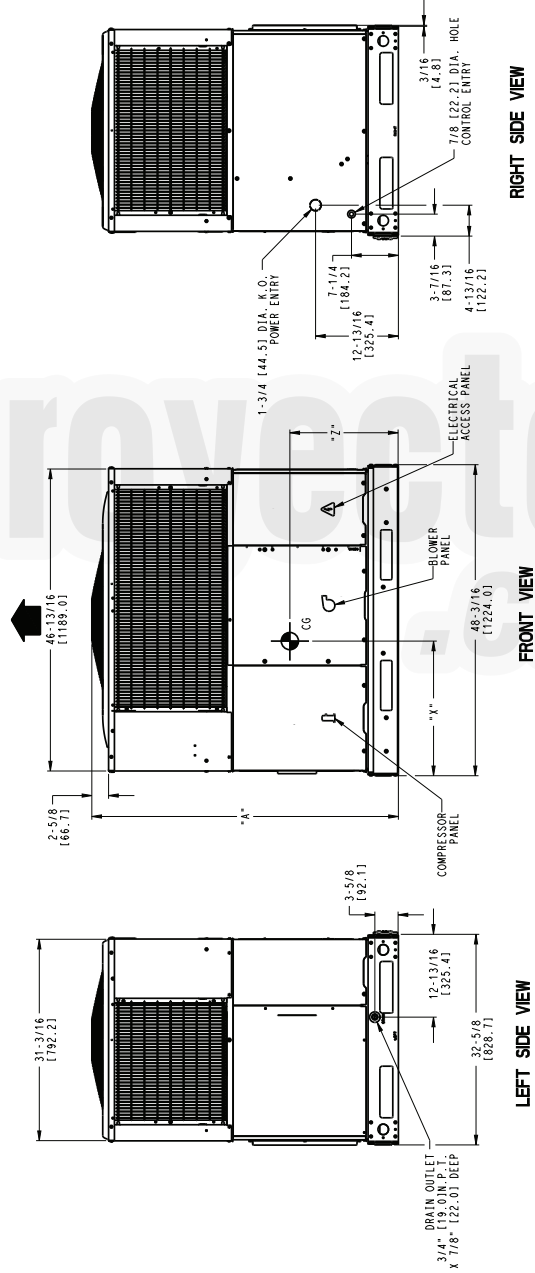
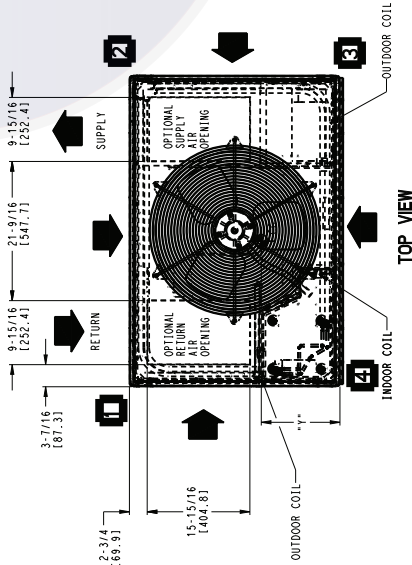

50VL500566

UNIT DIMENSIONS - 42-60

UNIT	ELECTRICAL CHARACTERISTICS			UNIT WT.		UNIT HEIGHT IN/MM			CENTER OF GRAVITY IN/MM			
	LB	KG	"A"	LB	KG	"A"	X	Y	Z			
50VL-C42---	(375/610)	208/230-1-60, 208/230-3-60, 460-3-60	413	187.0	44-3/4	1137	20-1/4	514.4	117-1/2	444.5	117-5/8	447.7
50VL-C48---	(375/610)	208/230-1-60, 208/230-3-60, 460-3-60	438	199.0	52-3/4	1340	20-1/4	514.4	117-1/2	444.5	117-5/8	447.7
50VL-C60---	(375/610)	208/230-1-60, 208/230-3-60, 460-3-60	455	206.0	54-3/4	1391	20-1/4	514.4	117-1/2	444.5	18	457.2

UNIT	CORNER WEIGHTS LB/KG								
	"1"	"2"	"3"	"4"					
42	208/230/460	62.0	28.1	82.6	37.5	123.9	56.2	144.6	65.6
48	208/230/460	65.7	29.8	81.6	39.7	131.4	59.6	153.3	69.5
60	208/230/460	66.3	31.0	91.0	47.3	136.5	61.9	159.3	72.2

REQUIRED CLEARANCES TO COMBUSTIBLE MATL.

TOP OF UNIT	INCHES [MM]
DUCT SIDE OF UNIT	14 [355.6]
SIDE OPPOSITE DUCTS	2 [50.8]
BOTTOM OF UNIT	0 [0.0]
ELECTRICAL PANEL	36 [914.4]

NEC. REQUIRED CLEARANCES.

BETWEEN UNITS, POWER ENTRY SIDE	INCHES [MM]
UNIT AND UNGROUNDED SURFACES, POWER ENTRY SIDE	42 [1066.8]
UNIT AND BLOCK OR CONCRETE WALLS AND OTHER GROUNDED SURFACES, POWER ENTRY SIDE	36 [914.0]

REQUIRED CLEARANCE FOR OPERATION AND SERVICING

EVAP. COIL ACCESS SIDE	INCHES [MM]
POWER ENTRY SIDE	36 [914.0]
(EXCEPT FOR NEC REQUIREMENTS)	48 [1219.2]
UNIT TOP	36 [914.0]
SIDE OPPOSITE DUCTS	36 [914.0]
DUCT PANEL	12 [304.8]

*MINIMUM DISTANCES: IF UNIT IS PLACED LESS THAN 12 [304.8] FROM WALL SYSTEM, THEN SYSTEM PERFORMANCE MAYBE COMPROMISED. DIMENSIONS IN () ARE IN MM

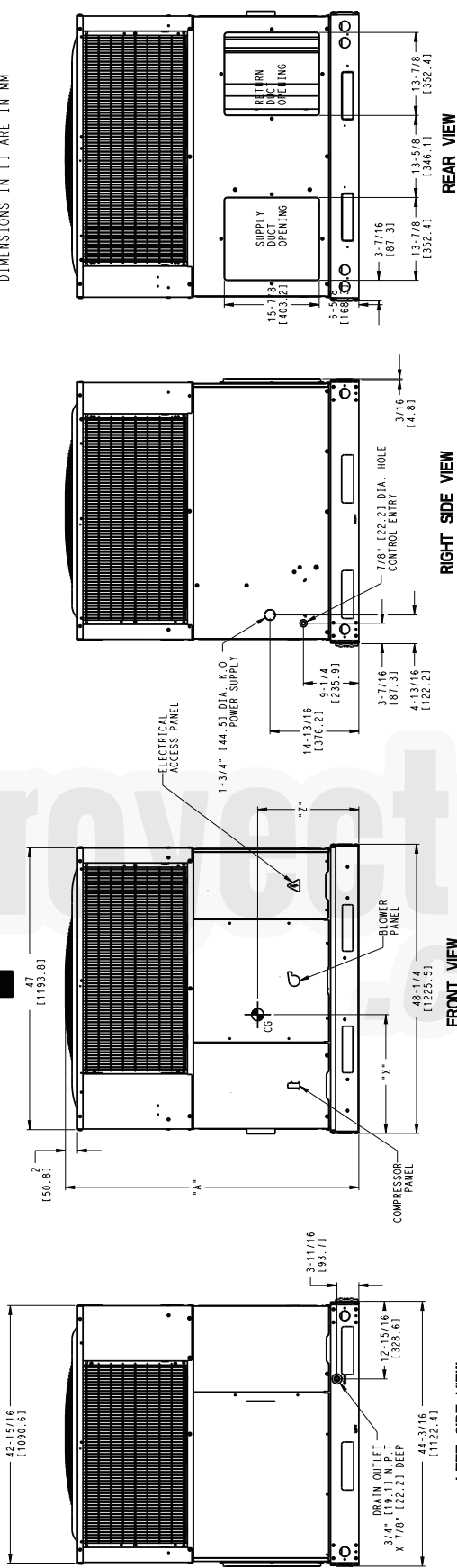
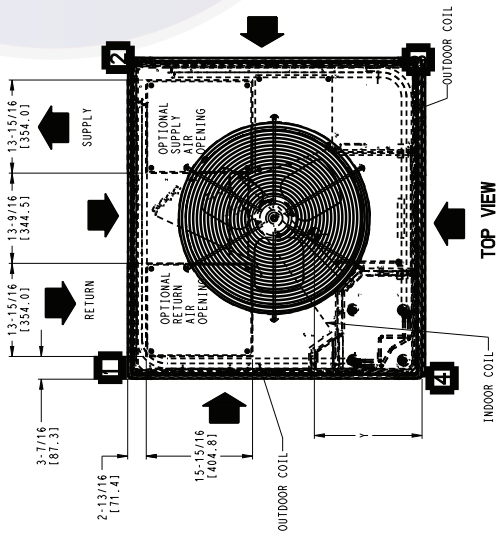

50VL500567

50VL-C

ROOF CURB ACCESSORY - 24-60

50VL-C

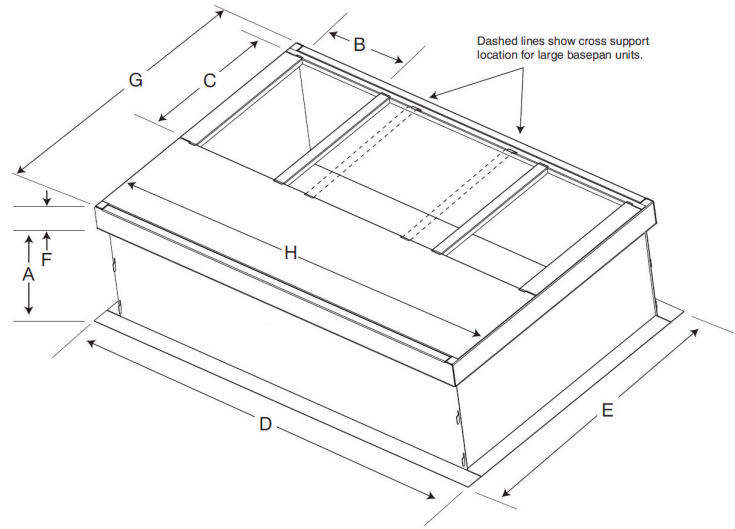
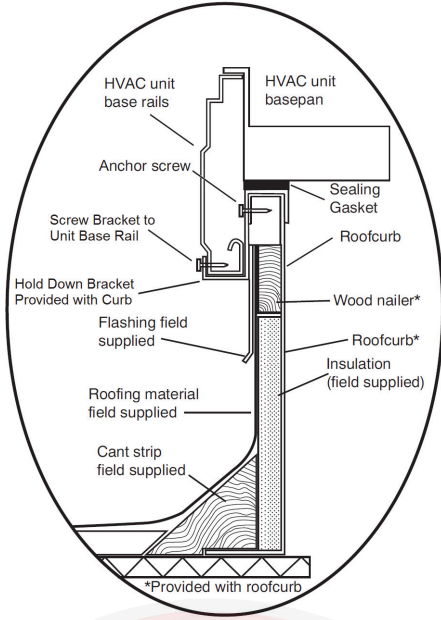

SMALL/COMMON CURB

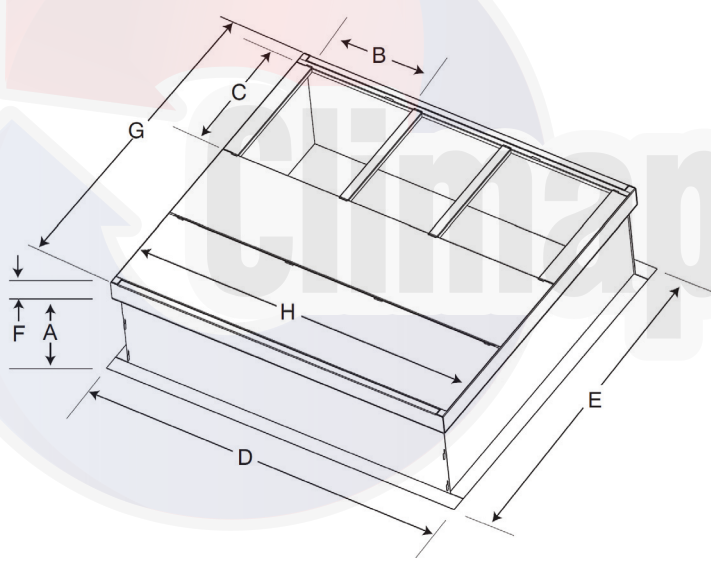

LARGE CURB

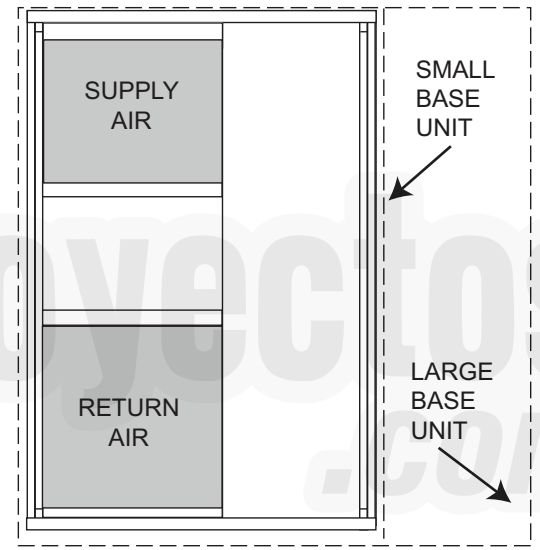

UNIT PLACEMENT ON COMMON CURB

SMALL OR LARGE BASE UNIT

A180216

UNIT SIZE	CATALOG NUMBER	A IN. (mm)	B (small/common base) IN. (mm)*	B (large base) IN. (mm)*	C IN. (mm)	D IN. (mm)	E IN. (mm)	F IN. (mm)	G IN. (mm)	H IN. (mm)
Small or Large	CPRFCURB011B00	14 (356)	10 (254)	14 (356)	16 (406)	47.8 (1214)	32.4 (822)	2.7 (69)	30.6 (778)	46.1 (1170)
Large	CPRFCURB013B00	14 (356)	14 (356)				43.9 (1116)		42.2 (1072)	

* Part Number CPRFCURB011B00 can be used on both small and large basepan units. The cross supports must be located based on whether the unit is a small basepan or a large basepan.

- NOTES:
1. Roof curb must be set up for unit being installed.
 2. Seal strip must be applied, as required, to unit being installed.
 3. Roof curb is made of 16-gauge steel.
 4. Attach ductwork to curb (flanges of duct rest on curb).
 5. Insulated panels: 1-in. (25.4 mm) thick fiberglass 1 lb. density.

SELECTION PROCEDURE (WITH EXAMPLE)

1. Determine cooling and heating requirements at design conditions:

Given:

Required Cooling Capacity (TC)	34,000 Btuh
Sensible Heat Capacity (SHC)	24,000 Btuh
Required Heating Capacity	12,500 Btuh
Condenser Entering Air Temperature	95°F(35°C)
Indoor-Air Temperature	80°F (26°C) edb 67°F (19°C) ewb
Evaporator Air Quantity	1200 CFM
External Static Pressure	0.20 IN. W.C.
Electrical Characteristics	230-1-60

2. Select unit based on required cooling capacity.

Enter Net Cooling Capacities table at condenser entering temperature of 95°F (35°C), indoor air entering at 1200 cfm and 67°F (19°C) ewb (entering wet bulb). The unit will provide a total capacity of 34,200 Btuh and a SHC of 24,500 Btuh.

3. Select electric heat.

The required heating capacity is 15,000 Btuh.

Determine additional electric heat capacity in kW.

$$\frac{15,000 \text{ Btuh}}{3,414 \text{ Btuh/kW}} = 4.4 \text{ kW of heat required}$$

Enter the electric Heater Packages table for 208/240, single-phase, 36 unit. The 5 kW heater at 240v most closely satisfies the heating required. To calculate kW at the 208v, multiply the heater kW by multiplication factor 0.75 found in the Wattage Multiplication Factors table.

$$5 \text{ kW} \times 0.75 = 3.75 \text{ kW}$$

$$3.75 \text{ kW} \times 3414 = 12802.50 \text{ Btuh}$$

4. Determine fan speed and power requirements at design conditions.

Before entering the air delivery tables, calculate the total static pressure required. From the given example, the Wet Coil Pressure Drop Table, and the Filter Pressure Drop Table:

External Static Pressure	0.200 IN. W.C.
Filter	0.000 IN. W.C.
Wet Coil Pressure Drop	<u>0.130 IN. W.C.</u>
Total Static Pressure	0.330 IN. W.C.

Enter the table for Wet Coil Air Delivery—horizontal discharge, 230. At 0.33 IN. W.C. ESP (external static pressure) and medium speed, the fan will deliver 1293 cfm. Adjusting for 208v, the motor delivers 114 cfm (deduct 10%).

5. Select unit that corresponds to power source available.

The Electrical Data Table shows that the unit is designed to operate at 208-1-60.

Climaproyectos.com

PERFORMANCE DATA

24 SIZE

EVAPORATOR AIR	CONDENSER ENTERING AIR TEMPERATURES ° F (° C)																		
	75 (23.9)			85 (29.4)			95 (35)			105 (40.6)			115 (46.1)			125 (51.7)			
	Capacity MBtuh	Total Sys KW	Sens	Capacity MBtuh	Total Sys KW	Sens	Capacity MBtuh	Total Sys KW	Sens	Capacity MBtuh	Total Sys KW	Sens	Capacity MBtuh	Total Sys KW	Sens	Capacity MBtuh	Total Sys KW	Sens	
700	57 (13.8)	23.62	23.62	21.90	21.90	21.90	20.07	20.07	20.07	17.88	17.88	17.88	15.87	15.87	15.87	14.01	14.01	14.01	2.64
	62 (16.6)	24.47	21.38	20.24	20.32	19.02	20.32	19.02	19.66	17.92	17.92	17.92	15.90	15.90	15.90	14.03	14.03	14.03	2.64
	63* (17.2)	24.99	17.43	16.39	20.71	15.32	20.71	15.32	1.96	18.05	14.06	14.06	15.56	12.87	12.87	13.28	11.77	11.77	2.61
	67 (19.4)	27.02	18.13	17.09	22.51	16.03	22.51	16.03	1.98	19.92	14.86	14.86	17.28	13.67	13.67	14.91	12.59	12.59	2.67
	72 (22.2)	29.59	14.70	13.77	24.84	12.86	24.84	12.86	1.99	22.48	11.95	11.95	19.68	10.89	10.89	17.14	9.92	9.92	2.77
800	57 (13.8)	24.74	24.74	22.92	22.92	21.02	21.02	21.02	1.99	18.78	18.78	18.78	16.65	16.65	16.65	14.70	14.70	14.70	2.69
	62 (16.6)	25.14	23.06	21.80	23.07	21.80	21.05	21.05	1.99	18.81	18.81	18.81	16.68	16.68	16.68	14.72	14.72	14.72	2.69
	63* (17.2)	25.59	18.60	17.53	21.18	16.43	21.18	16.43	1.99	18.51	15.14	15.14	15.93	13.90	13.90	13.61	12.73	12.73	2.64
	67 (19.4)	27.63	19.36	18.28	23.00	17.20	23.00	17.20	2.00	20.41	16.03	16.03	17.67	14.78	14.78	15.25	13.64	13.64	2.71
	72 (22.2)	30.16	15.42	14.48	25.27	13.55	25.27	13.55	2.01	22.88	12.64	12.64	20.12	11.62	11.62	17.47	10.60	10.60	2.80
900	57 (13.8)	25.69	25.69	23.77	23.77	21.80	21.80	21.80	2.01	19.55	19.55	19.55	17.32	17.32	17.32	15.29	15.29	15.29	2.73
	62 (16.6)	25.74	25.74	23.81	23.81	21.84	21.84	21.84	2.01	19.58	19.58	19.58	17.35	17.35	17.35	15.31	15.31	15.31	2.73
	63* (17.2)	26.07	19.72	18.62	21.55	17.49	21.55	17.49	2.01	18.84	16.17	16.17	16.24	14.87	14.87	13.92	13.92	13.92	2.67
	67 (19.4)	28.08	20.52	19.42	23.37	18.31	23.37	18.31	2.02	20.82	17.17	17.17	17.98	15.84	15.84	15.54	14.63	14.63	2.74
	72 (22.2)	30.58	16.10	15.15	25.58	14.21	25.58	14.21	2.02	23.17	13.29	13.29	20.45	12.30	12.30	17.73	11.25	11.25	2.83

See Legend and Notes on Page 18.

PERFORMANCE DATA (CONT)

30 SIZE

EVAPORATOR AIR		CONDENSER ENTERING AIR TEMPERATURES ° F (° C)																	
		75 (23.9)			85 (29.4)			95 (35)			105 (40.6)			115 (46.1)			125 (51.7)		
		CFM	EWB F (°C)	Capacity MBtuh	Total Sys KW	Capacity MBtuh	Total Sys KW	Capacity MBtuh	Total Sys KW	Capacity MBtuh	Total Sys KW	Capacity MBtuh	Total Sys KW	Capacity MBtuh	Total Sys KW	Capacity MBtuh	Total Sys KW		
875	57 (13.8)	29.53	29.53	1.96	27.08	27.08	2.16	24.69	24.69	2.37	22.28	22.28	2.58	19.59	19.59	2.78	16.70	16.70	2.97
	62 (16.6)	30.79	26.57	1.97	27.80	24.83	2.18	24.94	23.09	2.38	22.32	22.32	2.58	19.63	19.63	2.78	16.73	16.73	2.98
	63* (17.2)	31.48	21.67	1.98	28.41	20.10	2.19	25.42	18.58	2.39	22.40	17.07	2.58	18.92	15.39	2.74	15.25	13.63	2.90
	67 (19.4)	34.28	22.60	1.99	31.11	21.08	2.22	27.95	19.57	2.45	24.83	18.09	2.67	21.50	16.55	2.87	17.54	14.78	3.02
	72 (22.2)	37.52	18.32	2.02	34.41	17.04	2.25	31.17	15.74	2.49	27.94	14.44	2.73	24.64	13.15	2.98	20.76	11.69	3.20
1000	57 (13.8)	31.03	31.03	2.01	28.44	28.44	2.22	25.91	25.91	2.44	23.40	23.40	2.66	20.68	20.68	2.87	17.58	17.58	3.06
	62 (16.6)	31.72	28.62	2.01	28.67	26.73	2.23	25.96	25.96	2.45	23.44	23.44	2.67	20.72	20.72	2.87	17.61	17.61	3.06
	63* (17.2)	32.32	23.12	2.01	29.14	21.51	2.23	26.02	19.93	2.44	22.95	18.37	2.64	19.44	16.64	2.80	15.73	15.73	2.96
	67 (19.4)	35.07	24.07	2.03	31.85	22.55	2.26	28.60	21.00	2.49	25.37	19.46	2.72	21.99	17.88	2.94	17.99	16.02	3.08
	72 (22.2)	38.18	19.12	2.05	35.03	17.87	2.29	31.75	16.57	2.53	28.42	15.25	2.78	25.07	13.95	3.02	21.25	12.54	3.27
1125	57 (13.8)	32.29	32.29	2.04	29.60	29.60	2.27	26.94	26.94	2.50	24.33	24.33	2.73	21.55	21.55	2.96	18.32	18.32	3.14
	62 (16.6)	32.53	30.43	2.05	29.65	29.65	2.27	26.98	26.98	2.50	24.37	24.37	2.73	21.59	21.59	2.96	18.35	18.35	3.14
	63* (17.2)	32.95	24.48	2.05	29.71	22.85	2.27	26.51	21.21	2.49	23.38	19.60	2.70	19.89	17.80	2.86	16.36	16.36	3.03
	67 (19.4)	35.66	25.45	2.06	32.37	23.93	2.29	29.08	22.34	2.53	25.80	20.77	2.76	22.40	19.14	2.99	18.47	18.31	3.15
	72 (22.2)	38.66	19.84	2.08	35.48	18.63	2.32	32.15	17.34	2.57	28.78	16.01	2.82	25.36	14.70	3.07	21.59	13.33	3.31

See Legend and Notes on Page 18.

PERFORMANCE DATA (CONT)

36 SIZE

EVAPORATOR AIR		CONDENSER ENTERING AIR TEMPERATURES ° F (° C)																	
		75 (23.9)			85 (29.4)			95 (35)			105 (40.6)			115 (46.1)			125 (51.7)		
		Capacity MBtuh	Total Sys KW	EWB F (°C)	Capacity MBtuh	Total Sys KW	EWB F (°C)	Capacity MBtuh	Total Sys KW	EWB F (°C)	Capacity MBtuh	Total Sys KW	EWB F (°C)	Capacity MBtuh	Total Sys KW	EWB F (°C)	Capacity MBtuh	Total Sys KW	EWB F (°C)
1000	57 (13.8)	34.58	2.40	32.46	2.66	30.31	2.94	28.08	3.27	25.78	3.65	23.44	4.08	20.05	3.65	18.58	4.08	15.51	4.11
	62 (16.6)	36.10	2.41	33.65	2.67	31.16	2.95	28.62	3.27	26.05	3.65	23.48	4.08	20.05	3.65	18.58	4.08	15.51	4.11
	63* (17.2)	36.53	2.42	34.01	2.67	31.48	2.95	28.86	3.28	26.20	3.65	23.49	4.08	20.05	3.65	18.58	4.08	15.51	4.11
	67 (19.4)	39.44	2.43	36.74	2.69	34.00	2.97	31.20	3.30	28.34	3.67	25.45	4.09	21.07	3.67	19.58	4.09	15.51	4.11
	72 (22.2)	43.05	2.46	40.11	2.72	37.12	3.00	34.07	3.32	30.95	3.69	27.81	4.11	24.34	3.70	24.34	4.12	20.99	4.14
1150	57 (13.8)	36.19	2.46	33.98	2.71	31.67	3.00	29.30	3.32	26.84	3.70	24.34	4.12	20.99	3.72	19.88	4.12	15.51	4.11
	62 (16.6)	37.15	2.46	34.60	2.72	32.03	3.00	29.42	3.32	26.90	3.70	24.38	4.12	20.99	3.72	19.88	4.12	15.51	4.11
	63* (17.2)	37.52	2.47	34.89	2.72	32.23	3.01	29.50	3.33	26.72	3.70	24.38	4.12	20.99	3.72	19.88	4.12	15.51	4.11
	67 (19.4)	40.47	2.48	37.67	2.74	34.80	3.03	31.88	3.35	28.91	3.72	25.90	4.14	22.56	3.72	20.99	4.14	15.51	4.11
	72 (22.2)	44.12	2.51	41.04	2.77	37.93	3.06	34.77	3.38	31.54	3.74	28.28	4.16	27.71	3.75	25.08	4.17	21.11	4.17
1300	57 (13.8)	37.56	2.51	35.24	2.77	32.79	3.05	30.30	3.38	27.71	3.75	25.08	4.17	22.75	3.75	21.11	4.17	15.51	4.11
	62 (16.6)	38.06	2.51	35.47	2.77	32.84	3.05	30.34	3.38	27.75	3.75	25.12	4.17	22.75	3.75	21.11	4.17	15.51	4.11
	63* (17.2)	38.23	2.51	35.57	2.77	32.80	3.05	29.99	3.38	27.14	3.75	25.12	4.17	22.75	3.75	21.11	4.17	15.51	4.11
	67 (19.4)	41.26	2.53	38.33	2.79	35.38	3.08	32.36	3.40	29.31	3.76	26.22	4.18	24.01	3.76	22.34	4.18	17.10	4.21
	72 (22.2)	44.94	2.56	41.77	2.82	38.55	3.11	35.28	3.43	31.96	3.79	28.62	4.21	24.01	3.79	22.34	4.18	17.10	4.21

See Legend and Notes on Page 18.

PERFORMANCE DATA (CONT)

42 SIZE

EVAPORATOR AIR		CONDENSER ENTERING AIR TEMPERATURES ° F (° C)																	
		75 (23.9)			85 (29.4)			95 (35)			105 (40.6)			115 (46.1)			125 (51.7)		
		CFM	EWB F (° C)	Capacity MBtuh	Total Sys KW	Capacity MBtuh	Total Sys KW	Capacity MBtuh	Total Sys KW	Capacity MBtuh	Total Sys KW	Capacity MBtuh	Total Sys KW	Capacity MBtuh	Total Sys KW	Capacity MBtuh	Total Sys KW		
1175	57 (13.8)	38.66	38.66	2.51	36.66	36.66	2.87	34.60	34.60	3.30	32.45	32.45	3.80	30.07	30.07	4.39	27.19	27.19	5.02
	62 (16.6)	40.29	35.16	2.54	37.87	33.90	2.90	35.39	32.59	3.32	32.82	31.18	3.82	30.12	30.12	4.39	27.24	27.24	5.03
	63* (17.2)	41.08	28.70	2.54	38.62	27.55	2.92	36.06	26.34	3.34	33.40	25.10	3.84	30.40	23.73	4.40	26.65	22.06	4.98
	67 (19.4)	44.34	29.79	2.59	41.80	28.66	2.97	39.16	27.52	3.42	36.41	26.33	3.95	33.45	25.06	4.57	29.97	23.59	5.21
	72 (22.2)	48.52	24.17	2.66	45.92	23.18	3.05	43.20	22.16	3.52	40.37	21.10	4.06	37.44	20.00	4.70	34.27	18.84	5.44
	57 (13.8)	40.50	40.50	2.58	38.39	38.39	2.95	36.24	36.24	3.40	34.01	34.01	3.92	31.54	31.54	4.51	28.67	28.67	5.17
1350	62 (16.6)	41.38	37.85	2.59	38.93	36.52	2.96	36.44	36.11	3.41	34.06	34.06	3.92	31.59	31.59	4.52	28.72	28.72	5.17
	63* (17.2)	42.06	30.61	2.60	39.52	29.42	2.97	36.90	28.24	3.41	34.16	26.96	3.92	31.10	25.56	4.49	27.35	23.86	5.08
	67 (19.4)	45.33	31.78	2.64	42.72	30.67	3.03	40.00	29.50	3.48	37.18	28.29	4.01	34.18	27.02	4.64	30.76	25.56	5.32
	72 (22.2)	49.45	25.33	2.72	46.79	24.36	3.12	44.00	23.33	3.58	41.11	22.27	4.13	38.09	21.17	4.78	34.91	20.01	5.52
	57 (13.8)	41.99	41.99	2.63	39.82	39.82	3.02	37.59	37.59	3.47	35.28	35.28	4.01	32.78	32.78	4.63	29.92	29.92	5.31
	62 (16.6)	42.32	40.26	2.64	39.90	39.90	3.02	37.64	37.64	3.47	35.33	35.33	4.01	32.82	32.82	4.64	29.97	29.97	5.31
1525	63* (17.2)	42.81	32.42	2.65	40.22	31.23	3.02	37.53	30.01	3.47	34.76	28.74	3.99	31.66	27.29	4.56	27.97	25.57	5.17
	67 (19.4)	46.08	33.66	2.70	43.40	32.57	3.08	40.64	31.35	3.54	37.75	30.14	4.07	34.73	28.86	4.70	31.38	27.42	5.42
	72 (22.2)	50.14	26.41	2.78	47.44	25.44	3.18	44.60	24.44	3.64	41.64	23.37	4.20	38.57	22.27	4.85	35.35	21.11	5.59

See Legend and Notes on Page 18.

PERFORMANCE DATA (CONT)

48 SIZE

EVAPORATOR AIR		CONDENSER ENTERING AIR TEMPERATURES ° F (° C)																	
		75 (23.9)			85 (29.4)			95 (35)			105 (40.6)			115 (46.1)			125 (51.7)		
CFM	EWB F (° C)	Capacity MBtuh		Total Sys KW	Capacity MBtuh		Total Sys KW	Capacity MBtuh		Total Sys KW	Capacity MBtuh		Total Sys KW	Capacity MBtuh		Total Sys KW			
		Total	Sens		Total	Sens		Total	Sens		Total	Sens		Total	Sens		Total	Sens	
1400	57 (13.8)	45.45	45.45	3.10	42.83	42.83	3.46	40.16	40.16	3.89	37.26	37.26	4.36	33.52	33.52	4.82	29.80	29.80	5.37
	62 (16.6)	47.27	42.17	3.13	44.15	40.29	3.49	41.03	38.39	3.91	37.61	36.29	4.36	33.57	33.57	4.83	29.84	29.84	5.37
	63* (17.2)	48.20	34.32	3.13	45.02	32.66	3.50	41.76	30.98	3.92	38.24	29.20	4.38	33.54	26.93	4.82	28.81	24.65	5.33
	67 (19.4)	52.06	35.63	3.15	48.74	34.02	3.52	45.33	32.35	3.95	41.77	30.64	4.44	37.35	28.63	4.96	32.39	26.38	5.46
	72 (22.2)	56.98	28.79	3.18	53.50	27.36	3.56	49.89	25.89	3.99	46.16	24.36	4.48	42.23	22.80	5.04	37.37	21.00	5.64
1550	57 (13.8)	47.02	47.02	3.17	44.27	44.27	3.54	41.50	41.50	3.96	38.53	38.53	4.44	34.79	34.79	4.92	30.91	30.91	5.46
	62 (16.6)	48.16	44.46	3.17	45.01	42.51	3.55	41.85	40.45	3.97	38.60	38.60	4.44	34.83	34.83	4.92	30.95	30.95	5.46
	63* (17.2)	49.02	35.96	3.18	45.75	34.27	3.55	42.41	32.55	3.98	38.87	30.75	4.45	34.15	28.45	4.89	29.32	26.09	5.40
	67 (19.4)	52.88	37.35	3.20	49.49	35.71	3.57	46.00	34.00	4.00	42.38	32.25	4.49	38.03	30.31	5.04	32.93	27.95	5.53
	72 (22.2)	57.73	29.76	3.23	54.20	28.31	3.61	50.51	26.84	4.04	46.68	25.28	4.53	42.70	23.71	5.09	37.92	21.96	5.70
1800	57 (13.8)	49.14	49.14	3.25	46.25	46.25	3.63	43.34	43.34	4.06	40.29	40.29	4.55	36.55	36.55	5.07	32.46	32.46	5.60
	62 (16.6)	49.49	47.88	3.25	46.34	46.34	3.63	43.39	43.39	4.06	40.34	40.34	4.55	36.60	36.60	5.07	32.49	32.49	5.61
	63* (17.2)	50.04	38.56	3.25	46.70	36.84	3.63	43.27	35.06	4.06	39.66	33.20	4.54	34.96	30.85	5.00	30.05	28.30	5.51
	67 (19.4)	53.94	40.13	3.28	50.43	38.42	3.65	46.85	36.63	4.08	43.16	34.80	4.57	38.95	32.92	5.12	33.66	30.41	5.65
	72 (22.2)	58.67	31.28	3.31	55.06	29.83	3.69	51.26	28.32	4.12	47.34	26.73	4.62	43.27	25.12	5.18	38.61	23.50	5.78

See Legend and Notes on Page 18.

PERFORMANCE DATA (CONT)

60 SIZE

EVAPORATOR AIR		CONDENSER ENTERING AIR TEMPERATURES ° F (° C)																			
		75 (23.9)			85 (29.4)			95 (35)			105 (40.6)			115 (46.1)			125 (51.7)				
		Capacity MBtuh	Sens	Total Sys KW	Capacity MBtuh	Sens	Total Sys KW	Capacity MBtuh	Sens	Total Sys KW	Capacity MBtuh	Sens	Total Sys KW	Capacity MBtuh	Sens	Total Sys KW	Capacity MBtuh	Sens	Total Sys KW		
CFM	EWB °F (°C)	Total	Total	Total	Total	Total	Total	Total	Total	Total	Total	Total	Total	Total	Total	Total	Total	Total	Total		
1750	57 (13.8)	57.04	57.04	3.68	53.71	53.71	4.20	50.37	50.37	4.81	46.94	46.94	5.51	42.94	42.94	38.22	38.22	6.27	38.22	38.22	7.08
	62 (16.6)	58.59	49.98	3.70	54.72	48.26	4.22	50.83	46.41	4.82	47.02	47.02	5.51	43.00	43.00	38.29	38.29	6.28	38.29	38.29	7.08
	63* (17.2)	59.69	40.44	3.70	55.67	38.90	4.23	51.62	37.32	4.83	47.50	35.70	5.52	42.48	33.69	36.58	31.27	6.25	36.58	36.58	7.00
	67 (19.4)	64.43	42.04	3.73	60.26	40.56	4.26	56.00	39.00	4.87	51.67	37.39	5.57	47.05	35.71	41.05	33.47	6.38	41.05	41.05	7.21
	72 (22.2)	70.39	33.58	3.78	66.06	32.25	4.31	61.55	30.87	4.93	56.94	29.39	5.64	52.21	27.88	47.19	26.29	6.45	47.19	47.19	7.37
2000	57 (13.8)	59.44	59.44	3.78	55.93	55.93	4.31	52.41	52.41	4.92	48.83	48.83	5.62	44.92	44.92	39.97	39.97	6.44	39.97	39.97	7.26
	62 (16.6)	60.04	53.50	3.78	56.07	56.07	4.31	52.48	52.48	4.92	48.90	48.90	5.62	44.98	44.98	40.04	40.04	6.44	40.04	40.04	7.26
	63* (17.2)	60.84	43.04	3.78	56.74	41.49	4.31	52.56	39.87	4.92	48.32	38.18	5.62	43.48	36.25	37.36	33.66	6.39	37.36	37.36	7.13
	67 (19.4)	65.61	44.79	3.81	61.36	43.29	4.34	56.95	41.68	4.96	52.51	40.02	5.66	47.83	38.30	41.86	36.09	6.47	41.86	41.86	7.35
	72 (22.2)	71.45	35.11	3.87	67.02	33.78	4.40	62.40	32.37	5.02	57.67	30.89	5.73	52.81	29.36	47.75	27.77	6.55	47.75	47.75	7.47
2250	57 (13.8)	61.37	61.37	3.86	57.76	57.76	4.39	54.09	54.09	5.01	50.36	50.36	5.72	46.38	46.38	41.44	41.44	6.54	41.44	41.44	7.43
	62 (16.6)	61.42	61.42	3.86	57.83	57.83	4.40	54.15	54.15	5.01	50.42	50.42	5.72	46.44	46.44	41.51	41.51	6.54	41.51	41.51	7.43
	63* (17.2)	61.75	45.60	3.86	57.57	43.99	4.39	53.29	42.29	5.00	48.99	40.55	5.71	44.27	38.64	38.08	35.80	6.52	38.08	38.08	7.26
	67 (19.4)	66.46	47.42	3.89	62.10	45.93	4.43	57.67	44.25	5.04	53.13	42.53	5.75	48.44	40.74	42.58	38.56	6.56	42.58	42.58	7.48
	72 (22.2)	72.23	36.56	3.95	67.73	35.23	4.48	63.02	33.84	5.11	58.17	32.33	5.82	53.23	30.78	48.12	29.19	6.65	48.12	48.12	7.57

See Legend and Notes on Page 18.

PERFORMANCE DATA (CONT)

* At 75°F (24°C) entering dry bulb – Tennessee Valley Authority (TVA) rating conditions; all others at 80°F (27°C) dry bulb.

LEGEND

BF— Bypass Factor
 edb— Entering Dry – Bulb
 Ewb— Entering Wet – Bulb
 kW — Total Unit Power Input
 SHC— Sensible Heat Capacity (1000 Btuh)
 TC — Total Capacity (1000 Btuh) (net)
 rh— Relative Humidity

COOLING NOTES:

1. Ratings are net; they account for the effects of the evaporator—fan motor power and heat.
2. Direct interpolation is permissible. Do not extrapolate.
3. The following formulas may be used:

$$t_{ldb} = t_{edb} - \frac{\text{Sensible capacity (Btuh)}}{1.10 \times \text{cfm}}$$

$$t_{lwb} = \text{Wet-bulb temperature corresponding to enthalpy air leaving evaporator coil (} t_{lwb} \text{)}$$

$$h_{lwb} = \frac{\text{total capacity (Btuh)}}{4.5 \times \text{cfm}}$$

Where: h_{ewb} = Enthalpy of air entering evaporator coil

4. The SHC is based on 805 F (26.6°C) edb temperature of air entering evaporator coil. Below 80°F (26.6°C) edb, subtract (corr factor x cfm) from SHC.

Above 80° F (26.6° C) edb, add (corr factor x cfm) to SHC.

Correction Factor = $1.10 \times (1 + \text{BF}) \times (\text{edb} - 80)$.

5. Integrated capacity is maximum (instantaneous) capacity less the effect of frost on the outdoor coil and the heat required to defrost it.

Multiplication Factors

HEATER KW RATING	VOLTAGE DISTRIBUTION V/3/60	MULTIPLICATION FACTOR
240	200	0.69
	208	0.75
	230	0.92
	240	1.00

Dry Coil Air Delivery* - Horizontal and Downflow Discharge Sizes 24-60 208/230VAC 1 Phase Models

Unit Size	Motor Speed	Wire Color	External Static Pressure (IN. W.C.)																
			0.1	0.2	0.3	0.4	0.5	0.6	0.7	0.8	0.9	1							
24	Low	CFM	669	580	525	423	303	---	---	---	---	---	---	---	---	---	---	---	
		BHP	0.09	0.10	0.11	0.11	0.12	---	---	---	---	---	---	---	---	---	---	---	---
	Med - Low ¹	CFM	829	752	680	602	549	455	313	---	---	---	---	---	---	---	---	---	---
		BHP	0.14	0.15	0.15	0.16	0.17	0.17	0.18	---	---	---	---	---	---	---	---	---	---
	Medium	CFM	1014	929	884	818	746	683	600	537	405	305	---	---	---	---	---	---	---
		BHP	0.24	0.24	0.24	0.25	0.26	0.26	0.27	0.27	0.27	0.29	---	---	---	---	---	---	---
	Med - High	CFM	1041	972	916	850	782	713	631	581	465	340	---	---	---	---	---	---	---
		BHP	0.25	0.26	0.26	0.26	0.26	0.27	0.28	0.29	0.30	0.31	---	---	---	---	---	---	---
	High	CFM	1187	1124	1061	996	930	896	840	776	698	610	---	---	---	---	---	---	---
		BHP	0.36	0.36	0.37	0.37	0.38	0.38	0.39	0.39	0.39	0.40	---	---	---	---	---	---	---
30	Low	CFM	669	580	525	423	303	---	---	---	---	---	---	---	---	---	---	---	
		BHP	0.09	0.10	0.11	0.11	0.12	---	---	---	---	---	---	---	---	---	---	---	---
	Med - Low	CFM	829	752	680	602	549	455	313	---	---	---	---	---	---	---	---	---	---
		BHP	0.14	0.15	0.15	0.16	0.17	0.17	0.18	---	---	---	---	---	---	---	---	---	---
	Medium ¹	CFM	1014	929	884	818	746	683	600	537	405	305	---	---	---	---	---	---	---
		BHP	0.24	0.24	0.24	0.25	0.26	0.26	0.27	0.27	0.27	0.29	---	---	---	---	---	---	---
	Med - High	CFM	1041	972	916	850	782	713	631	581	465	340	---	---	---	---	---	---	---
		BHP	0.25	0.26	0.26	0.26	0.26	0.27	0.28	0.29	0.30	0.31	---	---	---	---	---	---	---
	High	CFM	1187	1124	1061	996	930	896	840	776	698	610	---	---	---	---	---	---	---
		BHP	0.36	0.36	0.37	0.37	0.38	0.38	0.39	0.39	0.39	0.40	---	---	---	---	---	---	---
36	Low	CFM	1056	982	911	882	812	740	667	564	486	361	---	---	---	---	---	---	
		BHP	0.24	0.24	0.24	0.24	0.26	0.27	0.28	0.29	0.30	0.30	---	---	---	---	---	---	---
	Med - Low	CFM	1174	1107	1045	985	914	890	825	760	673	572	---	---	---	---	---	---	---
		BHP	0.32	0.32	0.33	0.33	0.34	0.35	0.36	0.37	0.37	0.37	---	---	---	---	---	---	---
	Medium ¹	CFM	1246	1195	1148	1081	1019	953	884	859	795	690	---	---	---	---	---	---	---
		BHP	0.38	0.39	0.39	0.40	0.40	0.41	0.42	0.42	0.42	0.43	---	---	---	---	---	---	---
	Med - High	CFM	1361	1299	1229	1210	1152	1092	1025	958	889	822	---	---	---	---	---	---	---
		BHP	0.48	0.49	0.49	0.50	0.50	0.51	0.51	0.51	0.51	0.52	---	---	---	---	---	---	---
	High	CFM	1596	1542	1482	1424	1362	1304	1238	1173	1201	1143	---	---	---	---	---	---	---
		BHP	0.74	0.74	0.74	0.75	0.75	0.75	0.76	0.76	0.77	0.77	---	---	---	---	---	---	---
42	Low	CFM	1001	902	833	777	717	650	575	527	466	419	---	---	---	---	---	---	
		BHP	0.13	0.13	0.14	0.14	0.15	0.16	0.16	0.17	0.18	0.19	---	---	---	---	---	---	---
	Med - Low	CFM	1016	950	902	842	783	721	655	590	541	480	---	---	---	---	---	---	---
		BHP	0.13	0.14	0.15	0.16	0.17	0.18	0.19	0.20	0.21	0.22	---	---	---	---	---	---	---
	Medium ¹	CFM	1403	1358	1316	1265	1217	1167	1116	1067	1012	956	---	---	---	---	---	---	---
		BHP	0.29	0.30	0.31	0.33	0.34	0.35	0.36	0.37	0.38	0.39	---	---	---	---	---	---	---
	Med - High	CFM	1461	1411	1367	1327	1275	1220	1174	1127	1074	1022	---	---	---	---	---	---	---
		BHP	0.32	0.33	0.35	0.36	0.37	0.38	0.39	0.40	0.41	0.42	---	---	---	---	---	---	---
	High	CFM	1575	1528	1488	1447	1406	1360	1314	1264	1213	1159	---	---	---	---	---	---	---
		BHP	0.40	0.42	0.43	0.44	0.45	0.46	0.47	0.48	0.49	0.50	---	---	---	---	---	---	---

50VL-C



Dry Coil Air Delivery* - Horizontal and Downflow Discharge Sizes 24-60 208/230VAC 1 Phase Models (Cont.)

Unit Size	Motor Speed	Wire Color	External Static Pressure (IN. W.C.)									
			0.1	0.2	0.3	0.4	0.5	0.6	0.7	0.8	0.9	1
48	Low	CFM	1378	1344	1295	1260	1216	1179	1135	1087	1035	995
		BHP	0.26	0.27	0.29	0.31	0.31	0.33	0.34	0.36	0.36	0.38
	Med - Low ¹	CFM	1696	1671	1631	1607	1574	1539	1507	1463	1432	1393
		BHP	0.45	0.47	0.49	0.50	0.52	0.52	0.54	0.55	0.57	0.58
	Medium	CFM	1994	1968	1943	1910	1882	1835	1774	1702	1614	1512
		BHP	0.72	0.73	0.75	0.76	0.78	0.78	0.76	0.73	0.70	0.66
	Med - High	CFM	2054	2013	1986	1964	1919	1854	1779	1695	1605	1498
		BHP	0.77	0.79	0.80	0.82	0.81	0.80	0.76	0.74	0.69	0.65
	High	CFM	2267	2201	2133	2071	1997	1923	1835	1739	1654	1551
		BHP	1.03	1.00	0.97	0.93	0.89	0.86	0.82	0.78	0.74	0.69
60	Low	CFM	1380	1277	1232	1191	1147	1103	1060	1004	963	919
		BHP	0.26	0.27	0.29	0.30	0.31	0.32	0.33	0.34	0.36	0.37
	Med - Low	CFM	1475	1436	1399	1351	1317	1270	1236	1188	1152	1105
		BHP	0.35	0.36	0.37	0.38	0.40	0.41	0.42	0.43	0.45	0.45
	Medium ¹	CFM	1736	1710	1668	1630	1600	1557	1522	1479	1450	1406
		BHP	0.53	0.54	0.55	0.58	0.59	0.60	0.62	0.63	0.64	0.65
	Med - High	CFM	1935	1909	1867	1836	1808	1766	1696	1619	1535	1454
		BHP	0.71	0.73	0.74	0.76	0.78	0.79	0.77	0.75	0.72	0.68
	High	CFM	2205	2150	2078	2011	1941	1852	1779	1672	1572	1473
		BHP	1.04	1.02	0.99	0.95	0.92	0.87	0.85	0.79	0.75	0.70

*Air delivery values are without air filter and are for dry coil (See Wet Coil Pressure Drop table).

¹ Factory-shipped cooling speed

NOTE: Duct static pressure drop and wet coil pressure drop to obtain external static pressure available for ducting. Shaded areas indicate speed/static combinations that are not permitted for dehumidification speed.

Dry Coil Air Delivery* - Horizontal Discharge Sizes 36-60 3 Phase Models Only

Unit	Motor Speed	Wire Color	External Static Pressure (IN. W.C.)									
			0.1	0.2	0.3	0.4	0.5	0.6	0.7	0.8	0.9	
36	Low	Blue	CFM	979	912	859	789	731	654	556	454	374
	Med - Low	Pink	CFM	1136	1080	1015	957	912	861	808	723	633
	Medium ¹	Red	CFM	1208	1144	1091	1025	964	902	886	830	746
	Med - High	Orange	CFM	1495	1439	1376	1303	1221	1207	1137	1052	981
42	High	Black	CFM	1560	1491	1416	1337	1255	1233	1160	1082	998
	Low	Blue	CFM	952	882	806	746	671	605	530	486	
	Med - Low	Pink	CFM	1002	936	875	821	748	687	613	554	565
	Medium	Red	CFM	1255	1210	1145	1074	1008	940	878	895	838
48	Med - High ¹	Orange	CFM	1335	1267	1246	1176	1109	1049	988	926	872
	High	Black	CFM	1472	1401	1326	1251	1275	1198	1139	1085	1023
	Low	Blue	CFM	1402	1351	1311	1263	1224	1172	1136	1080	1041
	Med - Low	Pink	CFM	1457	1404	1367	1318	1284	1233	1197	1144	1104
60	Medium ¹	Red	CFM	1736	1695	1642	1601	1553	1512	1465	1427	1381
	Med - High	Orange	CFM	2149	2111	2062	2026	1980	1945	1905	1864	1793
	High	Black	CFM	2344	2306	2259	2203	2141	2070	1991	1902	1803
	Low	Blue	CFM	1445	1389	1341	1281	1236	1189	1139	1072	1027
60	Med - Low	Pink	CFM	1678	1635	1602	1558	1513	1474	1438	1404	1349
	Medium ¹	Red	CFM	1962	1915	1880	1843	1794	1753	1711	1675	1628
	Med - High	Orange	CFM	2131	2088	2065	2013	1982	1941	1888	1860	1785
	High	Black	CFM	2461	2409	2339	2286	2192	2140	2062	1968	1874

*Air delivery values are without air filter and are for dry coil (See Wet Coil Pressure Drop table).

¹ Factory-shipped cooling speed

Note: Ducted field-supplied air filter pressure drop and wet coil pressure drop to obtain external static pressure available for ducting. Shaded areas indicate speed/static combinations that are not permitted for dehumidification speed.



Dry Coil Air Delivery - Downflow Discharge Sizes 36-60 3 Phase Models Only

Unit	Motor Speed	Wire Color	External Static Pressure (IN. W.C.)											
			0.1	0.2	0.3	0.4	0.5	0.6	0.7	0.8	0.9	1.0		
36	Low	Blue	CFM	979	912	859	789	731	654	556	454	374	255	
			WATTS	202	212	217	221	231	236	245	251	259	253	
	Med - Low	Pink	BHP	0.22	0.23	0.23	0.24	0.25	0.25	0.25	0.26	0.27	0.27	
			CFM	1136	1080	1015	957	912	861	808	723	633	545	
				WATTS	294	309	310	322	325	333	341	349	354	367
				BHP	0.32	0.33	0.33	0.35	0.35	0.36	0.37	0.37	0.38	
				CFM	1208	1144	1091	1025	964	902	886	830	746	663
				WATTS	345	350	358	366	373	377	390	396	407	410
				BHP	0.37	0.38	0.38	0.39	0.40	0.40	0.42	0.42	0.44	0.44
				CFM	1495	1439	1376	1303	1221	1207	1137	1052	981	894
		Med - High	Orange	WATTS	625	634	635	633	624	613	598	583	573	551
				BHP	0.67	0.68	0.68	0.68	0.67	0.66	0.64	0.63	0.61	0.59
	High	Black	CFM	1560	1491	1416	1337	1255	1233	1160	1082	998	911	
			WATTS	708	699	683	674	660	634	624	606	581	566	
			BHP	0.76	0.75	0.73	0.72	0.71	0.68	0.67	0.65	0.62	0.61	
			CFM	952	882	806	746	671	605	530	551	486	435	
	Low	Blue	WATTS	124	134	140	150	156	166	171	182	188	198	
			BHP	0.13	0.14	0.15	0.16	0.17	0.18	0.18	0.20	0.20	0.21	
	Med - Low	Pink	CFM	1002	936	875	821	748	687	613	554	565	518	
			WATTS	144	155	161	171	176	187	193	203	209	220	
			BHP	0.15	0.17	0.17	0.18	0.19	0.20	0.21	0.22	0.22	0.24	
			CFM	1255	1210	1145	1074	1008	940	878	895	838	785	
	Medium	Red	WATTS	249	272	284	292	305	319	320	329	336	347	
			BHP	0.27	0.29	0.30	0.31	0.33	0.34	0.34	0.35	0.36	0.37	
	Med - High ¹	Orange	CFM	1335	1267	1246	1176	1109	1049	988	926	872	891	
			WATTS	311	323	330	342	356	367	378	385	395	403	
			BHP	0.33	0.35	0.35	0.37	0.38	0.39	0.41	0.41	0.42	0.43	
			CFM	1472	1401	1326	1251	1275	1198	1139	1085	1023	961	
	High	Black	WATTS	401	414	426	440	471	462	473	478	486	491	
			BHP	0.43	0.44	0.46	0.47	0.51	0.50	0.51	0.51	0.52	0.53	

Dry Coil Air Delivery – Downflow Discharge Sizes 36–60 3 Phase Models Only (Cont.)

Unit	Motor Speed	Wire Color	External Static Pressure (IN. W.C.)												
			0.1	0.2	0.3	0.4	0.5	0.6	0.7	0.8	0.9	1.0			
48	Low	Blue	CFM	1503	1457	1423	1374	1330	1287	1241	1199	1153	1111		
			WATTS	225	233	246	254	269	282	292	307	314	329		
	Med – Low	Pink	CFM	0.24	0.25	0.26	0.27	0.29	0.30	0.31	0.31	0.33	0.34	0.35	
			WATTS	1556	1508	1461	1432	1388	1346	1302	1256	1221	1168		
	Medium ¹	Red	BHP	244	261	268	281	290	305	319	330	345	353		
			CFM	0.26	0.28	0.29	0.30	0.31	0.33	0.34	0.35	0.37	0.38		
			WATTS	1861	1822	1786	1758	1716	1688	1660	1619	1583	1539		
			BHP	400	417	426	441	452	467	482	492	507	519		
			CFM	0.43	0.45	0.46	0.47	0.48	0.50	0.52	0.53	0.54	0.56		
			WATTS	2319	2291	2255	2230	2193	2166	2118	2057	1992	1887		
	High	Orange	BHP	758	769	787	799	808	823	822	805	780	737		
			CFM	0.81	0.82	0.84	0.86	0.87	0.88	0.88	0.86	0.84	0.79		
WATTS			2532	2487	2444	2391	2330	2259	2179	2111	2033	1949			
BHP			1014	1022	1015	994	965	935	898	858	823	786			
CFM			1.09	1.10	1.09	1.07	1.03	1.00	0.96	0.92	0.88	0.84			
WATTS			1479	1436	1387	1346	1298	1253	1206	1160	1114	1061			
Low	Blue	BHP	224	239	247	262	270	284	300	307	319	330			
		CFM	0.24	0.26	0.26	0.28	0.29	0.30	0.32	0.33	0.34	0.35			
		WATTS	1841	1796	1761	1724	1690	1651	1616	1578	1527	1478			
		BHP	425	434	453	460	476	485	501	508	525	542			
		CFM	0.46	0.47	0.49	0.49	0.51	0.52	0.54	0.54	0.56	0.58			
		WATTS	1944	1913	1872	1838	1801	1771	1731	1698	1655	1613			
Med – Low	Pink	BHP	486	501	511	529	537	554	565	578	595	603			
		CFM	0.52	0.54	0.55	0.57	0.58	0.59	0.61	0.62	0.64	0.65			
		WATTS	2178	2148	2105	2073	2036	2002	1967	1919	1845	1751			
		BHP	674	691	703	717	733	743	758	754	734	701			
		CFM	0.72	0.74	0.75	0.77	0.79	0.80	0.81	0.81	0.79	0.75			
		WATTS	2480	2432	2375	2322	2236	2161	2085	2006	1917	1808			
High	Black	BHP	1029	1012	995	975	941	908	869	836	796	751			
		CFM	1.10	1.09	1.07	1.05	1.01	0.97	0.93	0.90	0.85	0.81			
		WATTS	1029	1012	995	975	941	908	869	836	796	751			
		BHP	1.10	1.09	1.07	1.05	1.01	0.97	0.93	0.90	0.85	0.81			
		CFM	1.10	1.09	1.07	1.05	1.01	0.97	0.93	0.90	0.85	0.81			
		WATTS	1029	1012	995	975	941	908	869	836	796	751			

*Air delivery values are without air filter and are for dry coil (See Wet Coil Pressure Drop table).

¹ Factory-shipped cooling speed

NOTE: Ductwork field-supplied air filter pressure drop and wet coil pressure drop to obtain external static pressure available for ducting. Shaded areas indicate speed/static combinations that are not permitted for dehumidification speed.

PERFORMANCE DATA (CONT)**Wet Coil Pressure Drop (IN. W.C.)**

UNIT SIZE	STANDARD CFM (SCFM)																
	600	700	800	900	1000	1100	1200	1300	1400	1500	1600	1700	1800	1900	2000	2100	2200
24	0.03	0.04	0.04	0.05	0.06												
30				0.05	0.06	0.07	0.08	0.11									
36				0.06	0.06	0.09	0.10	0.11	0.14								
42					0.05	0.05	0.06	0.07	0.08	0.08	0.09	0.09	0.11				
48							0.04	0.06	0.09	0.10	0.10	0.11	0.12	0.13	0.14		
60									0.06	0.07	0.07	0.08	0.09	0.10	0.10	0.12	0.13

Economizer with 1-in. Filter Pressure Drop (IN. W.C.)

FILTER SIZE IN. (MM)	COOLING TONS	STANDARD CFM (SCFM)																
		600	700	800	900	1000	1100	1200	1300	1400	1500	1600	1700	1800	1900	2000	2100	2200
600-1400CFM 12x20x1+12x20x1 (305x508x25+305x508x25)	2.0,	-	-	0.09	0.14	0.16	0.18	0.25	0.28	0.3	-	-	-	-	-	-	-	-
	2.5,																	
	3.0																	
1200-1800 CFM 16x24x1+14x24x1 (406x610x25+356x610x25)	3.5,	-	-	-	-	-	-	0.10	0.11	0.12	0.13	0.14	0.16	0.16	-	-	-	-
	4.0																	
1500-2200 CFM 16x24x1+18x24x1 (406x610x25+457x610x25)	5.0	-	-	-	-	-	-	-	-	-	0.15	0.17	0.18	0.20	0.21	0.22	0.23	0.23

Horizontal and Downflow Filter Pressure Drop Table (IN. W.C.)

FILTER SIZE IN. (MM)	COOLING TONS	STANDARD CFM (SCFM)																
		600	700	800	900	1000	1100	1200	1300	1400	1500	1600	1700	1800	1900	2000	2100	2200
600-1400CFM 12x20x1+12x20x1 (305x508x25+305x508x25)	2.0,	0.03	0.05	0.06	0.08	0.10	0.11	0.13	0.14	0.16	-	-	-	-	-	-	-	-
	2.5,																	
	3.0																	
1200-1800 CFM 16x24x1+14x24x1 (406x610x25+356x610x25)	3.5,	-	-	-	-	-	-	0.07	0.08	0.09	0.09	0.10	0.11	0.12	-	-	-	-
	4.0																	
1500-2200 CFM 16x24x1+18x24x1 (406x610x25+457x610x25)	5.0	-	-	-	-	-	-	-	-	-	0.04	0.06	0.08	0.10	0.11	0.13	0.14	0.15

**Electric Heat Pressure Drop Tables (IN. W.C.)
Small Cabinet: 24-36**

STATIC	STANDARD CFM (SCFM)																
	500	600	700	800	900	1000	1100	1200	1300	1400	1500	1600					
5 kW	0.00	0.00	0.00	0.00	0.00	0.00	0.00	0.00	0.02	0.02	0.04	0.04	0.06	0.06	0.07	0.07	0.07
10 kW	0.00	0.00	0.00	0.00	0.00	0.02	0.04	0.06	0.06	0.07	0.09	0.10	0.10	0.11	0.11	0.11	0.11
15 kW	0.00	0.00	0.00	0.02	0.04	0.06	0.08	0.10	0.12	0.14	0.16	0.16	0.17	0.17	0.17	0.17	0.17
20 kW	0.00	0.00	0.02	0.04	0.06	0.08	0.09	0.11	0.13	0.15	0.17	0.17	0.18	0.18	0.18	0.18	0.18

Large Cabinet: 42-60

STATIC	STANDARD CFM (SCFM)																
	1100	1200	1300	1400	1500	1600	1700	1800	1900	2000	2100	2200	2300	2400	2500		
5 kW	0.00	0.00	0.00	0.01	0.02	0.03	0.04	0.05	0.06	0.07	0.08	0.09	0.10	0.11	0.12	0.12	0.12
10 kW	0.00	0.00	0.01	0.02	0.03	0.04	0.05	0.06	0.07	0.08	0.09	0.10	0.11	0.12	0.12	0.13	0.13
15 kW	0.00	0.02	0.03	0.04	0.05	0.06	0.07	0.08	0.09	0.10	0.11	0.12	0.13	0.14	0.14	0.15	0.15
20 kW	0.02	0.03	0.04	0.05	0.06	0.07	0.08	0.09	0.10	0.11	0.12	0.13	0.14	0.15	0.15	0.16	0.16

TYPICAL PIPING AND WIRING

50VL-C

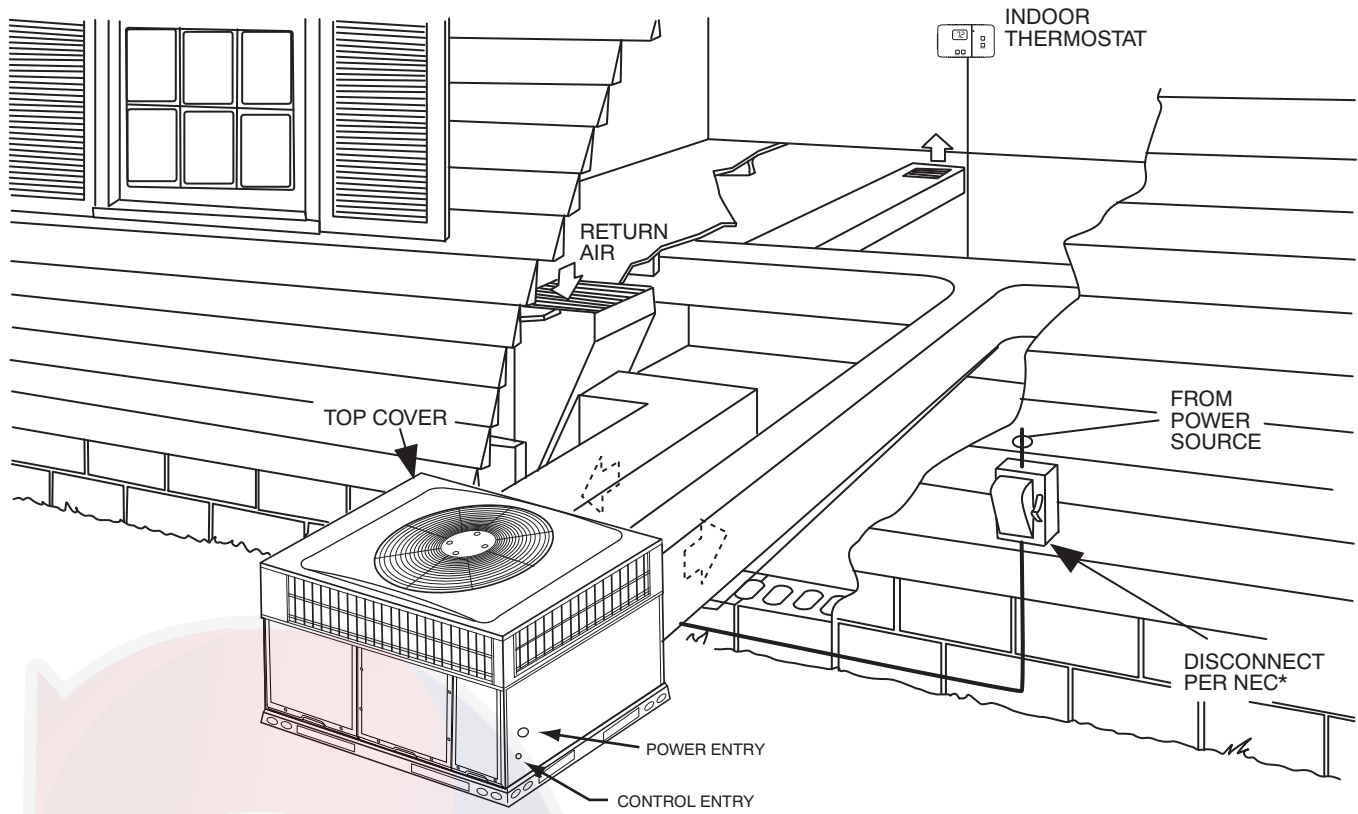

*NEC - National Electrical Code
A09240

APPLICATION DATA

Condensate trap — A 2-in. (50.8 mm) condensate trap must be field supplied.

Ductwork — Secure downflow discharge ductwork to roof curb. For horizontal discharge applications, attach ductwork to unit with flanges.

To convert a unit to downflow discharge — Units are equipped with factory-installed inserts in the downflow openings. Removal of the inserts is similar to removing an electrical knock-out.

Maximum cooling airflow — To minimize the possibility of condensate blow-off from the evaporator, airflow through the units should not exceed 450 cfm per ton.

Minimum cooling airflow — Minimum cooling airflow is 350 cfm per ton.

Minimum ambient cooling operation temperature — All standard units have a minimum ambient operating temperature of 40°F (4°C). With accessory low ambient temperature kit, units can operate at temperatures down to 0°F (-17°C).

ELECTRICAL DATA

MODEL SIZE	NOMINAL V-PH-HZ	VOLTAGE RANGE		COMPRESSOR		OFM	IFM	NOMINAL ELECTRIC HEAT	POWER SUPPLY			
		MIN	MAX	RLA	LRA	FLA	FLA		kW	FLA	MCA	MOCP
24	208/230-1-60	197	253	8.7	46	0.6	3.8	-/-	-/-	15.2	20	
								3.8/5	18.1/20.8	27.4/30.8	30/35	
								5.4/7.2	25.9/30	37.1/42.3	40/45	
								7.5/10	36.1/41.7	49.9/56.9	50/60	
30	208/230-1-60	197	253	11.2	57	0.7	3.8	-/-	-/-	18.5	25	
								3.8/5	18.1/20.8	27.4/30.8	30/35	
								5.4/7.2	25.9/30	37.1/42.3	40/45	
								7.5/10	36.1/41.7	49.9/56.9	50/60	
36	208/230-1-60	197	253	16.7	79	1	5.4	11.3/15	54.2/62.5	72.5/82.9	80/90	
								-/-	-/-	27.4	40	
								3.8/5	18.1/20.8	29.4/32.8	40/40	
								5.4/7.2	25.9/30	39.1/44.3	40/45	
	208/230-3-60	197	253	10.4	73	1	6	7.5/10	36.1/41.7	51.9/58.9	60/60	
								11.3/15	54.2/62.5	74.5/84.9	80/90	
								-/-	-/-	20.1	30	
								3.8/5	10.4/12	20.5/22.5	30/30	
	460-3-60	414	506	5.8	38	0.5	3.2	7.5/10	20.8/24.1	33.5/37.6	35/40	
								11.3/15	31.2/36.1	46.5/52.6	50/60	
								-/-	-/-	11	15	
								10	12	19	20	
42	208/230-1-60	197	253	16.7	109	1	3.8	15	18	26.5	30	
								-/-	-/-	25.8	40	
								3.8/5	18.1/20.8	27.4/30.8	40/40	
								5.4/7.2	25.9/30	37.1/42.3	40/45	
	208/230-3-60	197	253	11.2	88	1	4.1	7.5/10	36.1/41.7	49.9/56.9	50/60	
								11.3/15	54.2/62.5	72.5/82.9	80/90	
								15/20	72.2/83.3	95/108.9	100/110	
								-/-	-/-	19.2	30	
	460-3-60	414	506	5.6	44	0.5	3.2	3.8/5	10.4/12	19.2/20.1	30/30	
								7.5/10	20.8/24.1	31.1/35.3	35/40	
								11.3/15	31.2/36.1	44.1/50.3	45/60	
								15/20	41.4/47.9	56.9/65	60/70	
48	208/230-1-60	197	253	19.6	130	1	7.6	-/-	-/-	10.7	15	
								3.8/5	18.1/20.8	33.2/35.5	50/50	
								5.4/7.2	25.9/30	41.9/47	50/50	
								7.5/10	36.1/41.7	54.6/61.6	60/70	
	208/230-3-60	197	253	13.7	83.1	1	7.6	11.3/15	54.2/62.5	77.3/87.6	80/90	
								15/20	72.2/83.3	99.8/113.6	100/125	
								-/-	-/-	25.8	35	
								3.8/5	10.4/12	25.8	35/35	
	460-3-60	414	506	6.2	41	0.5	4	7.5/10	20.8/24.1	35.5/39.6	40/40	
								11.3/15	31.2/36.1	48.5/54.6	50/60	
								15/20	41.4/47.9	61.3/69.4	70/70	
								-/-	-/-	12.3	15	
60	208/230-1-60	197	253	23.7	152.5	1	7.6	10	12	20	20	
								15	18	27.5	30	
								20	24.1	35.1	40	
								-/-	-/-	38.3	60	
	208/230-3-60	197	253	15.9	110	1	7.6	3.8/5	18.1/20.8	38.3	60/60	
								5.4/7.2	25.9/30	41.9/47	60/60	
								7.5/10	36.1/41.7	54.6/61.6	60/70	
								11.3/15	54.2/62.5	77.3/87.6	80/90	
	460-3-60	414	506	7.1	52	0.5	4	15/20	72.2/83.3	99.8/113.6	100/125	
								-/-	-/-	28.6	40	
								3.8/5	10.4/12	28.6	40/40	
								7.5/10	20.8/24.1	35.5/39.6	40/40	

50VL-C

ELECTRICAL DATA (CONT)

LEGEND

- FLA - Full Load Amps
- IDM - Inducer Motor
- IFM - Indoor Fan Motor
- LRA - Locked Rotor Amps
- MCA - Minimum Circuit Amps
- MOCP - Maximum Over Current Protection
- OFM - Outdoor Fan Motor
- RLA - Rated Load Amps

NOTES:

1. In compliance with NEC (National Electrical Code) requirements for multimotor and combination load equipment (refer to NEC Articles 430 and 440), the overcurrent protective device for the unit shall be Power Supply fuse or circuit breaker.
2. Minimum wire size is based on 60 C copper wire. If other than 60 C wire is used, or if length exceeds wire length in table, determine size from NEC.
3. Unbalanced 3-Phase Supply Voltage
Never operate a motor where a phase imbalance in supply voltage is greater than 2%. Use the following formula to determine the percentage of voltage imbalance

$$\% \text{ Voltage imbalance} = 100 \times \frac{\text{max voltage deviation from average voltage}}{\text{average voltage}}$$

EXAMPLE: Supply voltage is 230-3-60.

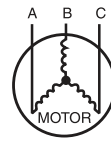

AB = 228 v
BC = 231 v
AC = 227 v

$$\begin{aligned} \text{Average Voltage} &= \frac{228 + 231 + 227}{3} \\ &= \frac{686}{3} \\ &= 229 \end{aligned}$$

Determine maximum deviation from average voltage.

(AB) 229 - 228 = 1 v
(BC) 231 - 229 = 2 v
(AC) 229 - 227 = 2 v

Maximum deviation is 2 v.

Determine percent of voltage imbalance

$$\begin{aligned} \% \text{ Voltage Imbalance} &= 100 \times \frac{2}{229} \\ &= 0.8\% \end{aligned}$$

This amount of phase imbalance is satisfactory as it is below the maximum allowable 2%.

IMPORTANT: If the supply voltage phase imbalance is more than 2%, contact your local electric utility company immediately.

A06564

50VL-C

Climaproyectos.com

CONNECTION WIRING SCHEMATIC 208/230-1-60

CONNECTION WIRING DIAGRAM

DANGER: ELECTRICAL SHOCK HAZARD DISCONNECT POWER BEFORE SERVICING

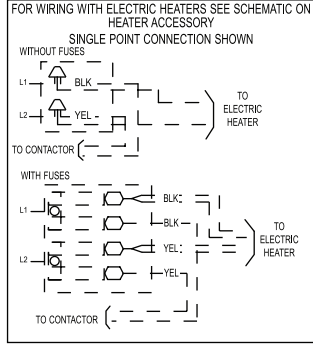

SCHEMATIC 208/230V-1-60

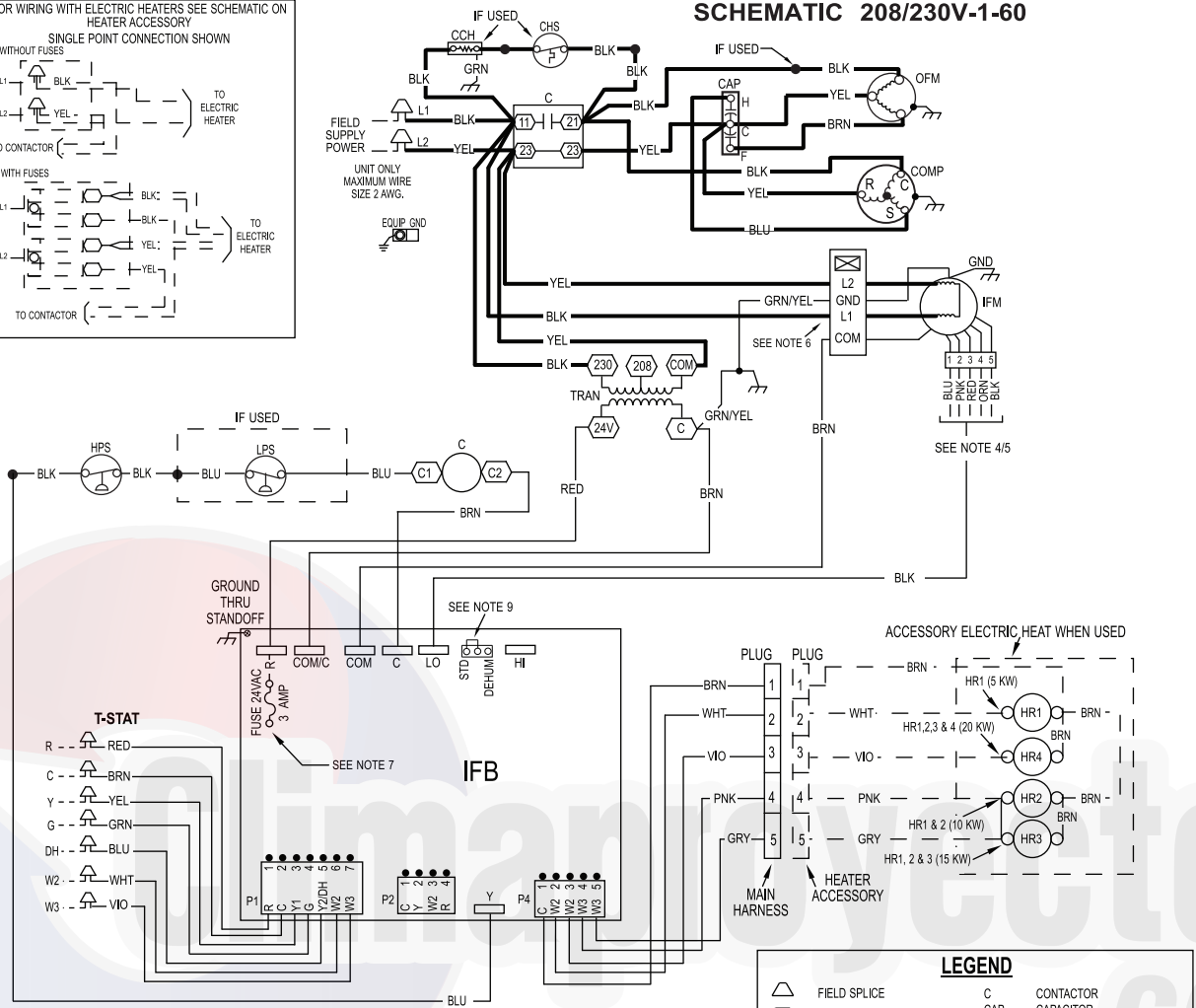

UNIT COMPONENT ARRANGEMENT

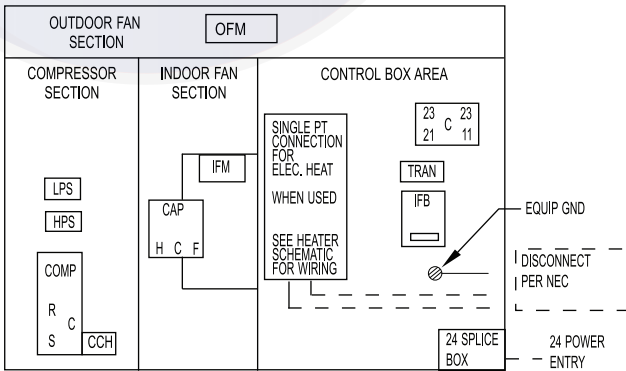

LEGEND

	FIELD SPLICE	C	CONTACTOR
	TERMINAL (MARKED)	CAP	CAPACITOR
	TERMINAL (UNMARKED)	CCH	CRANKCASE HEATER
	SPLICE	CHS	CRANKCASE HEATER SWITCH
	SPLICE (MARKED)	COMP	COMPRESSOR MOTOR
	FACTORY LO VOLTAGE	CTD	COMPRESSOR TIME DELAY
	FIELD CONTROL WIRING	DH	DEHUM
	FIELD POWER WIRING	GND	GROUND
	ACCESSORY OR OPTIONAL WIRING	HPS	HIGH PRESSURE SWITCH
	FACTORY HI VOLTAGE	HR	HEATER RELAY
		IFB	INDOOR FAN BOARD
		IFM	INDOOR FAN MOTOR
		LPS	LOW PRESSURE SWITCH
		OFM	OUTDOOR FAN MOTOR
		TRAN	TRANSFORMER
		T-STAT	THERMOSTAT

NOTES:

- IF ANY OF THE ORIGINAL WIRES FURNISHED ARE REPLACED IT MUST BE REPLACED WITH THE SAME OR IT'S EQUIVALENT.
- SEE PRE SALE LITERATURE FOR THERMOSTATS.
- USE 75 DEGREES C COPPER CONDUCTORS FOR FIELD INSTALLATION.
- REFER TO INSTALLATION INSTRUCTIONS FOR CORRECT SPEED SELECTION FOR IFM.
- RELOCATION OF SPEED TAPS MAY BE REQUIRED WHEN USING FIELD INSTALLED ELECTRIC HEATERS. CONSULT INSTALLATION INSTRUCTIONS TO DETERMINE CORRECT SPEED TAP SETTING.
- "DO NOT DISCONNECT PLUG UNDER LOAD".
- THIS FUSE IS MANUFACTURED BY LITTLE FUSE, P/N 287003.
- N.E.C. CLASS 2, 24V.
- UNIT FACTORY - SHIPPED IN STD MODE.
- DISCONNECT PER NEC
- 24V SPLICE BOX - 24V POWER ENTRY
- CCH NOT USED ON ALL UNITS.

50VL-C

LADDER WIRING SCHEMATIC 208/230-1-60

LADDER WIRING DIAGRAM

DANGER: ELECTRICAL SHOCK HAZARD DISCONNECT POWER BEFORE SERVICING

USE COPPER CONDUCTORS ONLY

FIELD SUPPLY

EQUIP GND

208/230 VAC. 60 HZ. 1PH

50VL-C

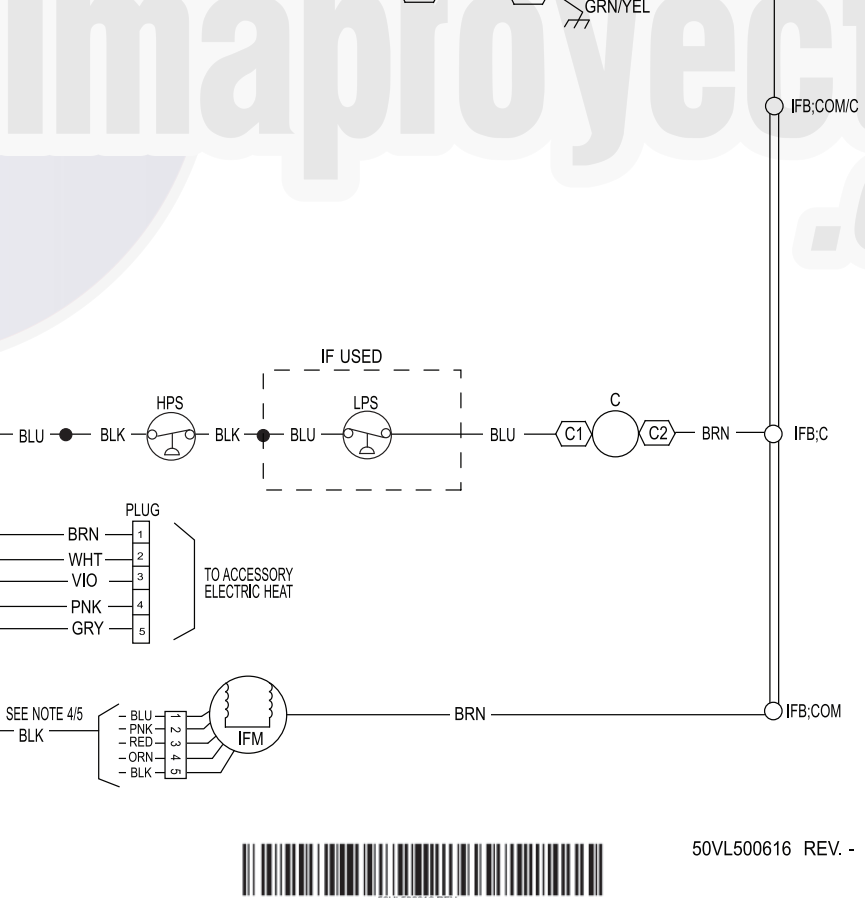
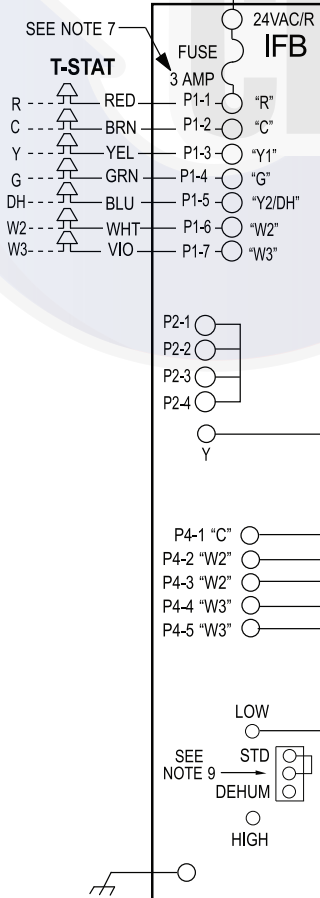
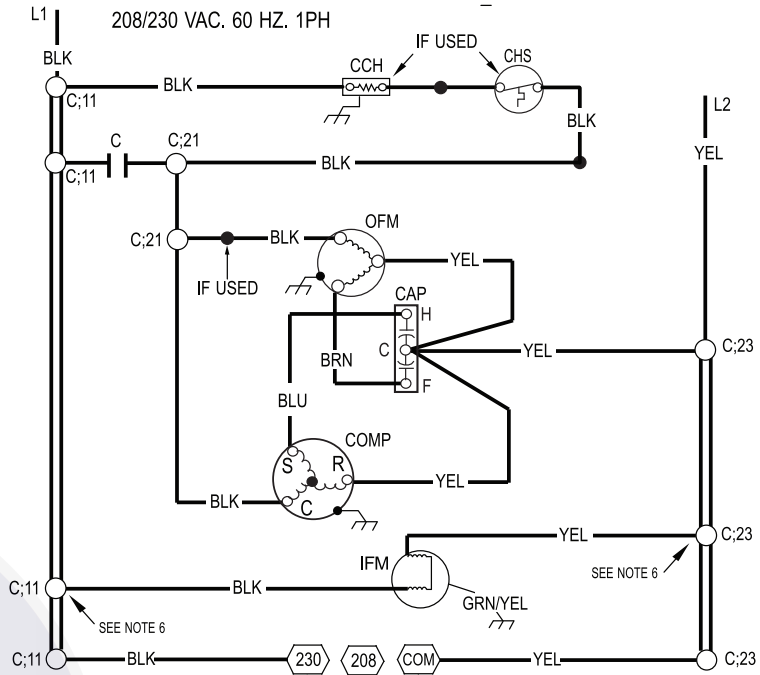

50VL500616 REV. 1



A150513

CONNECTION WIRING SCHEMATIC 208/230-3-60

CONNECTION WIRING DIAGRAM

DANGER: ELECTRICAL SHOCK HAZARD DISCONNECT POWER BEFORE SERVICING

SCHEMATIC 208/230V-3-60

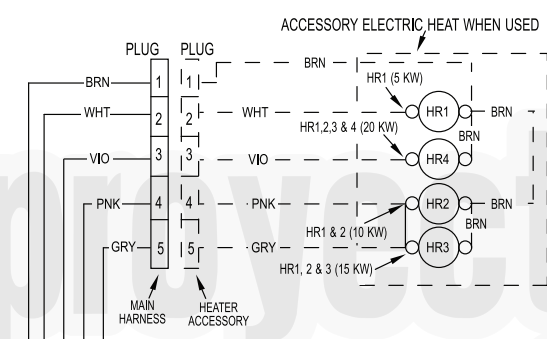
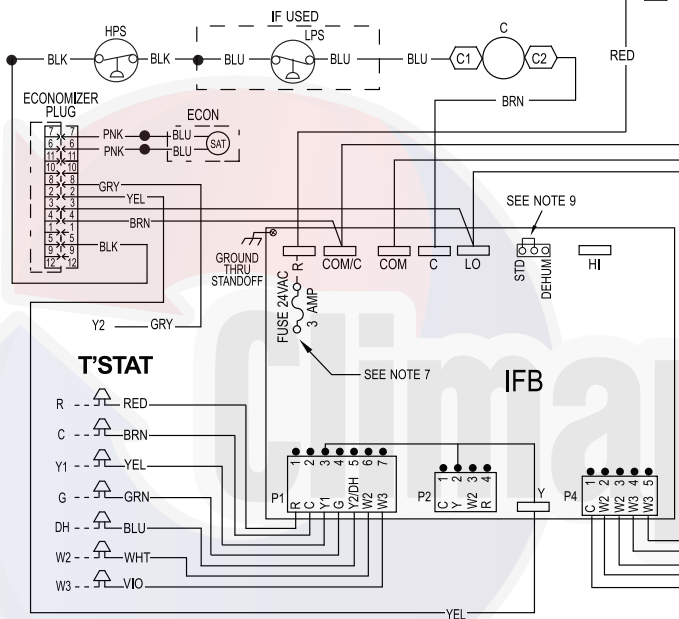
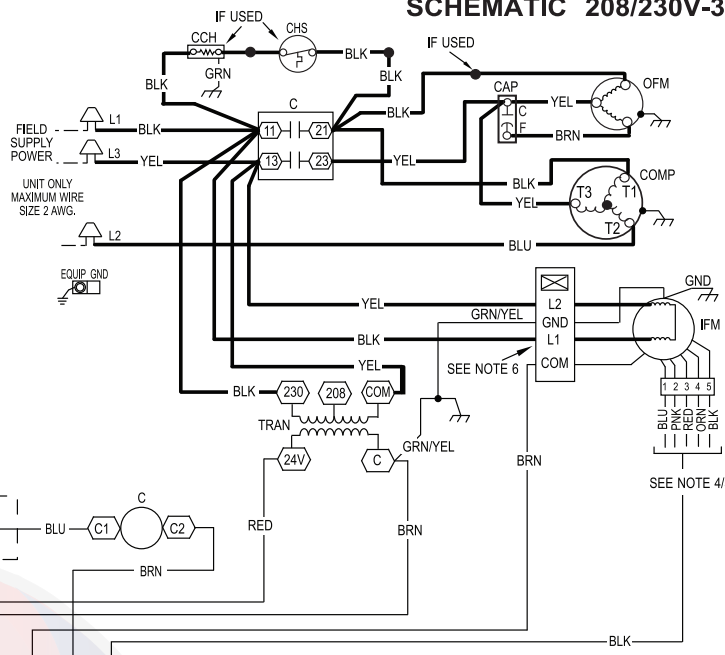
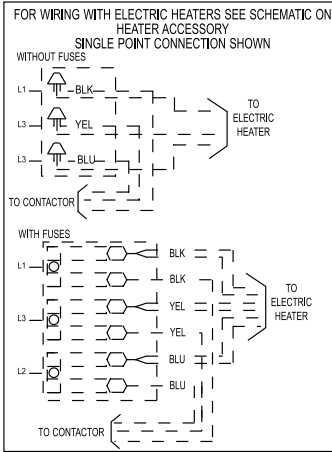

UNIT COMPONENT ARRANGEMENT

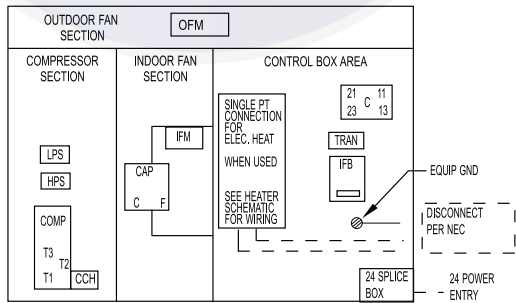

LEGEND			
	FIELD SPLICE	CCH	CRANKCASE HEATER
	TERMINAL (MARKED)	CHS	CRANKCASE HEATER SWITCH
	TERMINAL (UNMARKED)	COMP	COMPRESSOR MOTOR
	FIELD CONTROL WIRING	CTD	COMPRESSOR TIME DELAY
	FIELD POWER WIRING	DH	DEHUMIDIFICATION MODE
	ACCESSORY OR OPTIONAL WIRING	DEHUM	DEHUMIDIFICATION MODE
	FACTORY LO VOLTAGE	ECON	ECONOMIZER
	FACTORY HI VOLTAGE	GND	GROUND
	SPICE	HPS	HIGH PRESSURE SWITCH
	SPICE (MARKED)	HR	HEATER RELAY
	SPICE (MARKED)	IFB	INDOOR FAN BOARD
	SPICE (MARKED)	IFM	INDOOR FAN MOTOR
	SPICE (MARKED)	LPS	LOW PRESSURE SWITCH
	SPICE (MARKED)	OFM	OUTDOOR FAN MOTOR
	SPICE (MARKED)	STD	STANDARD MODE
	SPICE (MARKED)	TRAN	TRANSFORMER
	SPICE (MARKED)	T-STAT	THERMOSTAT

NOTES:

- IF ANY OF THE ORIGINAL WIRES FURNISHED ARE REPLACED IT MUST BE REPLACED WITH THE SAME OR IT'S EQUIVALENT.
- SEE PRE SALE LITERATURE FOR THERMOSTATS.
- USE 75 DEGREES C COPPER CONDUCTORS FOR FIELD INSTALLATION.
- REFER TO INSTALLATION INSTRUCTIONS FOR CORRECT SPEED SELECTION FOR IFM.
- RELOCATION OF SPEED TAPS MAY BE REQUIRED WHEN USING FIELD INSTALLED ELECTRIC HEATERS. CONSULT INSTALLATION INSTRUCTIONS TO DETERMINE CORRECT SPEED TAP SETTING.
- "DO NOT DISCONNECT PLUG UNDER LOAD".
- THIS FUSE IS MANUFACTURED BY LITTLE FUSE, P/N 287003.
- N.E.C. CLASS 2, 24V.
- DEHUM FEATURE CANNOT BE USED WHEN ECONOMIZER IS INSTALLED.
- UNIT FACTORY - SHIPPED IN STD MODE.
- CCH NOT USED ON ALL UNITS.

50VL-C

LADDER WIRING SCHEMATIC 208/230-3-60

LADDER WIRING DIAGRAM

DANGER: ELECTRICAL SHOCK HAZARD DISCONNECT POWER BEFORE SERVICING

50VL-C

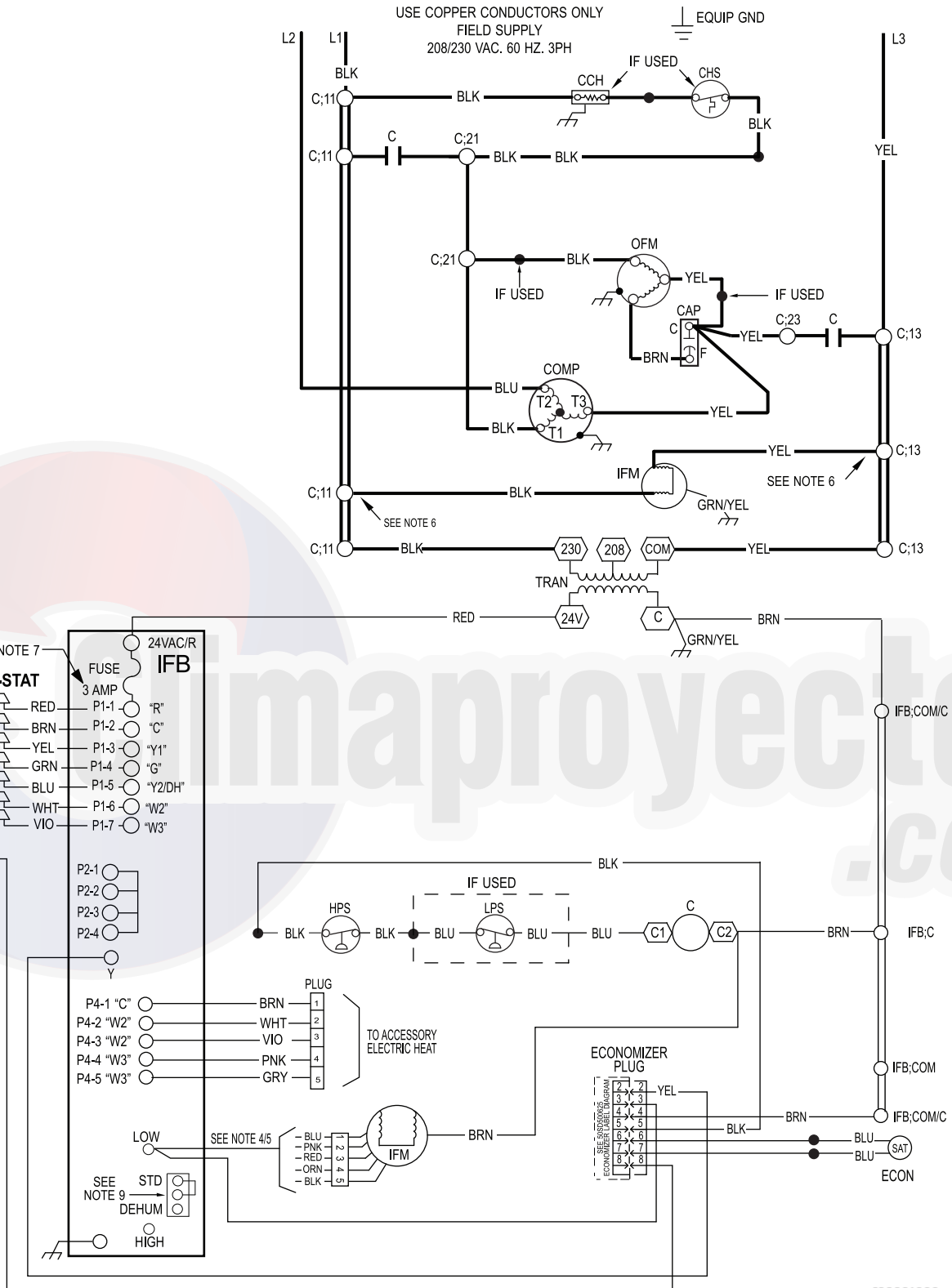

50VL500617 REV. -

50VL500617 REV. -



A150514

CONNECTION WIRING SCHEMATIC 460-3-60

CONNECTION WIRING DIAGRAM

DANGER: ELECTRICAL SHOCK HAZARD DISCONNECT POWER BEFORE SERVICING

SCHEMATIC 460-3-60

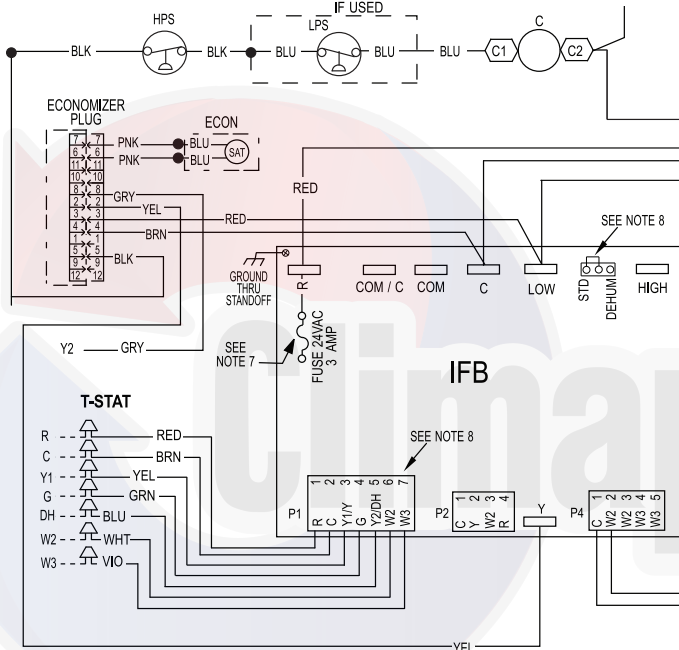
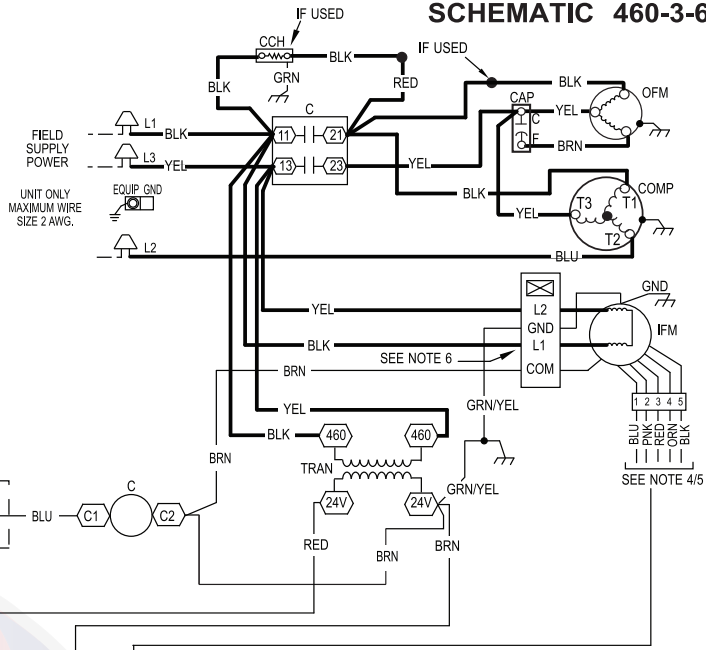
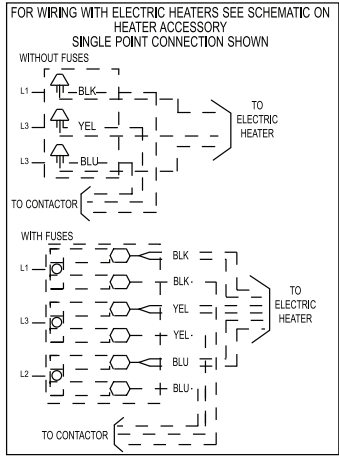

ACCESSORY ELECTRIC HEAT WHEN USED

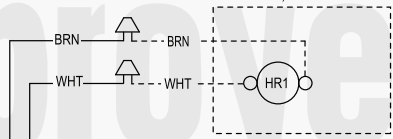

UNIT COMPONENT ARRANGEMENT

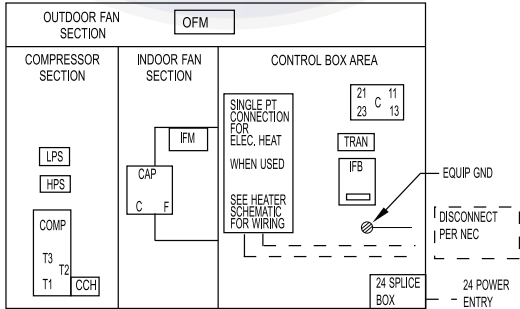

LEGEND			
	FIELD SPLICE	CCH	CRANKCASE HEATER
	TERMINAL (MARKED)	COMP	COMPRESSOR MOTOR
	TERMINAL (UNMARKED)	DH	DEHUMIDIFICATION MODE
	SPLICE	DEHUM	DEHUMIDIFICATION MODE
	SPLICE (MARKED)	ECON	ECONOMIZER
	FACTORY LO VOLTAGE	GND	GROUND
	FIELD CONTROL WIRING	HPS	HIGH PRESSURE SWITCH
	FIELD POWER WIRING	HR	HEATER RELAY
	ACCESSORY OR OPTIONAL WIRING	IFB	INDOOR FAN BOARD
	FACTORY HI VOLTAGE	IFM	INDOOR FAN MOTOR
C	CONTACTOR	LPS	LOW PRESSURE SWITCH
CAP	CAPACITOR	OFM	OUTDOOR FAN MOTOR
		STD	STANDARD MODE
		TRAN	TRANSFORMER
		T-STAT	THERMOSTAT

NOTES:

- IF ANY OF THE ORIGINAL WIRES FURNISHED ARE REPLACED IT MUST BE REPLACED WITH THE SAME OR ITS EQUIVALENT.
- SEE PRE SALE LITERATURE FOR THERMOSTATS.
- USE 75 DEGREES C COPPER CONDUCTORS FOR FIELD INSTALLATION.
- REFER TO INSTALLATION INSTRUCTIONS FOR CORRECT SPEED SELECTION FOR IFM.
- RELOCATION OF SPEED TAPS MAY BE REQUIRED WHEN USING FIELD INSTALLED ELECTRIC HEATERS. CONSULT INSTALLATION INSTRUCTIONS TO DETERMINE CORRECT SPEED TAP SETTING.
- "DO NOT DISCONNECT PLUG UNDER LOAD".
- THIS FUSE IS MANUFACTURED BY LITTLE FUSE, P/N 287003.
- DEHUM FEATURE CANNOT BE USED WHEN ECONOMIZER IS INSTALLED.
- UNIT FACTORY - SHIPPED IN STD MODE.
- N.E.C. CLASS 2, 24V.
- CCH NOT USED ON ALL UNITS.

50VL-C

LADDER WIRING SCHEMATIC 460-3-60

LADDER WIRING DIAGRAM

DANGER: ELECTRICAL SHOCK HAZARD DISCONNECT POWER BEFORE SERVICING

50VL-C

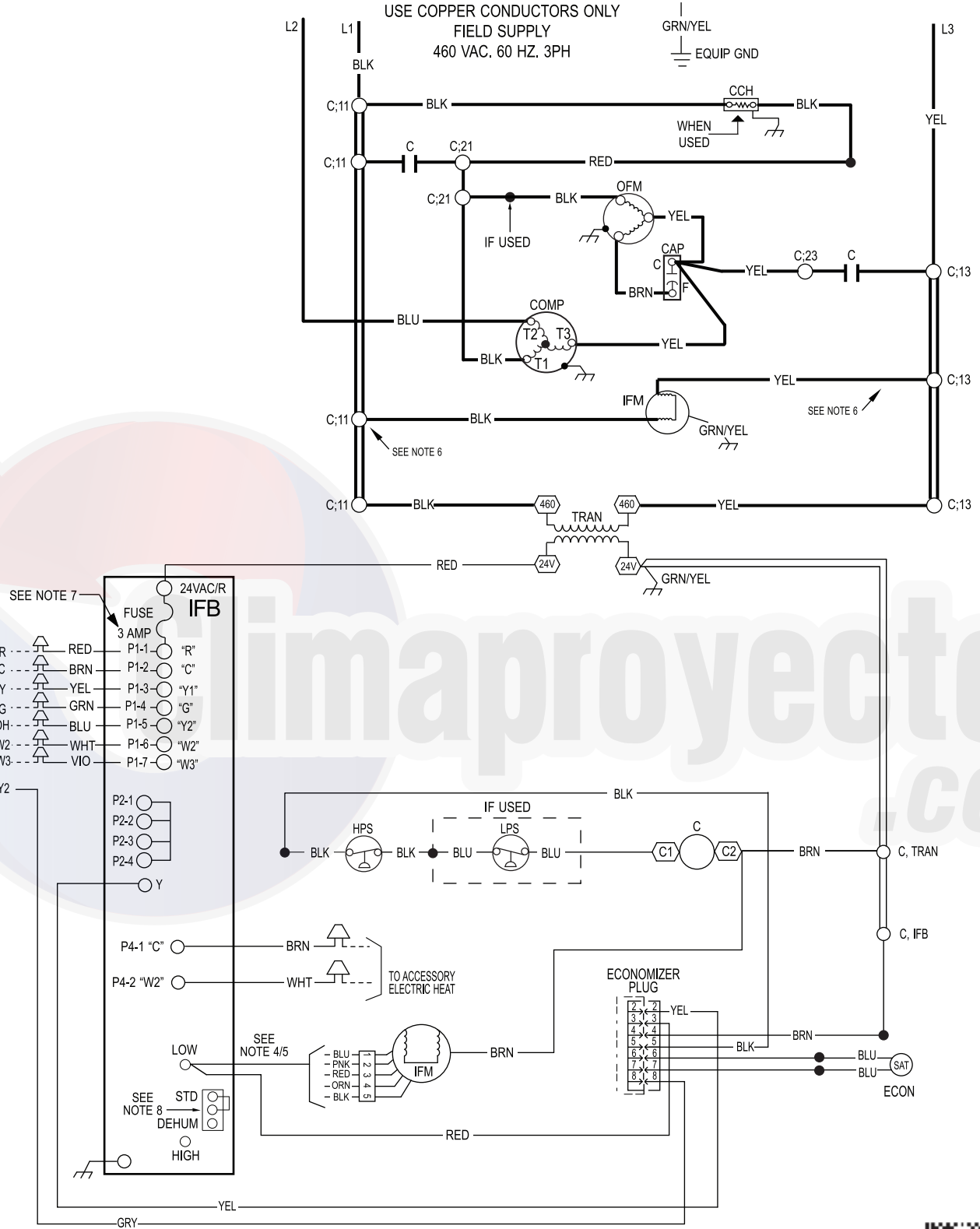

50VL500619 REV. 1



A150515

CONTROLS

Operating sequence

Cooling — When the system thermostat calls for cooling, 24 V is supplied to the “Y” and “G” terminals of the thermostat. This completes the circuit to the contactor coil (C) and indoor (evaporator) fan relay (IFR). The normally open contacts of energized C close and complete the circuit through compressor motor (COMP) to outdoor (condenser) fan motor (OFM). Both motors start instantly. The set of normally open contacts of energized IFR close and complete the circuit through IFM. The IFM starts instantly.

On the loss of the thermostat call for cooling, 24 V is removed from both the “Y” and “G” terminals (provided the fan switch is in the “AUTO” position) de-energizing the compressor contactor and opening the contacts supplying power to compressor/OFM. After a 90-second delay, the IFM shuts off. If the thermostat fan selector switch is in the “ON” position, the IFM will run continuously. For the 460 V units there is a step down autotransformer supplying 230 V to the Indoor Fan Motor.

NOTE: On units with a Time Guard® II device: Once the compressor has started and then stopped, it cannot be restarted again until 5 minutes have elapsed.

Heating — If accessory electric heaters are installed, on a call for heat, circuit R-W is made through the thermostat contacts. Circuit R-G is made which energizes the IFR. If the heaters are staged, then the thermostat closes a second set of contacts (W2) when second stage is required. When thermostat is satisfied, contacts open, deenergizing the heater relay and the IFR.

50VL-C



GUIDE SPECIFICATIONS

Packaged Air Conditioner System Constant Volume Application HVAC Guide Specifications

Size Range: **2 to 5 Tons, Nominal Cooling**

SYSTEM DESCRIPTION

Outdoor rooftop mounted or ground mounted, electric cooling unit utilizing a hermetic scroll compressor for cooling duty. Unit shall discharge supply air vertically or horizontally as shown on contract drawings. Condenser fan/coil section shall have a draw-thru design with vertical discharge for minimum sound levels.

QUALITY ASSURANCE

- A. Unit shall be rated in accordance with AHRI Standards 210/240 and 270-1995.**
- B. Unit shall be designed in accordance with UL Standard 1995.**
- C. Unit shall be manufactured in a facility registered to ISO 9001 manufacturing quality standard.**
- D. Unit shall be UL listed and c-UL certified as a total package for safety requirements.**
- E. Roof curb shall be designed to conform to NRCA Standards.**
- F. Insulation and adhesives shall meet NFPA 90A requirements for flame spread and smoke generation.**
- G. Cabinet insulation shall meet ASHRAE Standard 62P.**

DELIVERY, STORAGE AND HANDLING

Unit shall be stored and handled per manufacturer's recommendations.

Part 2 — Products

EQUIPMENT

A. General:

Factory-assembled, single-piece, heating and cooling unit. Contained within the enclosure shall be all factory wiring, piping, controls, refrigerant charge with R-410A refrigerant, and special features required prior to field start-up.

B. Unit Cabinet:

- 1. Unit cabinet shall be constructed of phosphated, zinc-coated, pre-painted steel capable of with-standing 500 hours in salt spray.
- 2. Normal service shall be through 3 removable cabinet panels.
- 3. The unit shall be constructed on a rust proof unit base that has an externally trapped, integrated sloped drain.
- 4. Evaporator fan compartment top surface shall be insulated with a minimum 1/2-in. (12.7 mm) thick, flexible fiberglass insulation, coated on the air side and retained by adhesive and mechanical means. The evaporator wall sections will be insulated with a minimum semi-rigid foil-faced board capable of being wiped clean. Aluminum foil-faced fiberglass insulation shall be used in the entire indoor air cavity section.
- 5. Unit shall have a field-supplied condensate trap.

C. Fans:

- 1. The evaporator fan shall be an ECM Motor.
- 2. Fan wheel shall be made from steel, be double-inlet type with forward curved blades with corrosion resistant finish. Fan wheel shall be dynamically balanced.
- 3. Condenser fan shall be direct drive propeller type with aluminum blades riveted to corrosion resistant steel spiders, be dynamically balanced, and discharge air vertically.

D. Compressor:

- 1. Fully hermetic compressors with factory-installed vibration isolation.

E. Coils:

Evaporator and condenser coils shall have aluminum plate fins mechanically bonded to seamless copper tubes with all joints brazed. Tube sheet openings shall be belled to prevent tube wear.

F. Refrigerant Components:

Refrigerant expansion device shall be of the TXV (thermostatic expansion valve) or fixed orifice type.

G. Filters:

Filter section shall consist of field-installed, throwaway, 1-in. (25 mm) thick fiberglass filters of commercially available sizes.

H. Controls and Safeties:

- 1. Unit controls shall be complete with a self-contained low voltage control circuit.
- 2. Compressors shall incorporate a solid-state compressor protector that provides reset capability.

I. Operating Characteristics:

- 1. Unit shall be capable of starting and running at 125°F (51°C) ambient outdoor temperature per maximum load criteria of AHRI Standard 210.
- 2. Compressor with standard controls shall be capable of operation down to 40°F (4°C) ambient outdoor temperature.
- 3. Units shall be provided with fan time delay to prevent cold air delivery before the heat exchanger warms up.
- 4. Unit shall be provided with 60-second fan time delay after the thermostat is satisfied.

J. Electrical Requirements:

All unit power wiring shall enter the unit cabinet at a single location.

K. Motors:

- 1. Compressor motors shall be of the refrigerant-cooled type with line-break thermal and current overload protection.
- 2. All fan motors shall have permanently lubricated bearings, and inherent, automatic reset, thermal overload protection.

L. Special Features:

- 1. Coil Options:
Base unit with tin plated indoor coil hairpins.
- 2. Compressor Start Kit (single phase units only):
Shall provide additional starting torque for single-phase compressors.
- 3. Thermostat:
To provide for one-stage heating and cooling in addition manual or automatic changeover and indoor fan control.
- 4. Crankcase Heater:
Shall provide anti-floodback protection for low-load cooling applications.
- 5. Economizer:
(Horizontal - Field installed accessory)
(Vertical - Field installed accessory)
 - a. Economizer controls capable of providing free cooling using outside air.
 - b. Equipped with low leakage dampers not to exceed 3% leakage, at 1.0 IN. W.C. pressure differential.
 - c. Spring return motor shuts off outdoor damper on power failure.

GUIDE SPECIFICATIONS (CONT)

6. Electric Heaters:
 - a. Electric heater shall be available as a field-installed option.
 - b. Heater elements shall be open wire type, adequately supported and insulated with ceramic bushings.
 - c. Electric heater packages must provide single point power connection capability.
7. Filter Rack Kit:

Shall provide filter mounting for downflow applications. Offered as a field installed accessory.
8. Flat Roof Curb:

Curbs shall have seal strip and a wood nailer for flashing and shall be installed per manufacturer's instructions.
9. Low Ambient Package:

Shall consist of a solid-state control and condenser coil temperature sensor for controlling condenser-fan motor operation, which shall allow unit to operate down to 0°F (-17.7°C) outdoor ambient temperature when properly installed.
10. Manual Outdoor Air Damper:

Package shall consist of damper, birdscreen, and rainhood which can be preset to admit outdoor air for year-round ventilation.
11. Square-To-Round Duct Transitions (24-48 size):

Shall have the ability to convert the supply and return openings from rectangular to round.
12. Time Guard II
Automatically prevents the compressor from restarting for at least 4 minutes and 45 seconds after shutdown of the compressor. Not required when a corporate programmable thermostat is applied or with a RTU-MP control. Offered as a field installed accessory.
13. Dual Point Electric Heaters
Allows you to power the electric heater and unit contactor separately by having two individual field power supply circuits connected respectively.
14. Cabinet air leakage of 2.0% or less at .5 in. W.C. when tested in accordance with ASHRAE standard 193. Available as a factory installed option.
15. Louver Metal Outdoor Coil Grille
Shall provide hail and vandalism protection. Available as a field installed accessory.
16. Low Pressure Switch
Kit is designed for use when a low pressure control is desired. This kit provides added reliability for the compressor. Offered as a field installed accessory.

50VL-C



Climaproyectos
.com





