

558J

COOLING ONLY/ELECTRIC HEAT PACKAGED ROOFTOP UNITS  
HORIZONTAL MODELS, NOMINAL TONS 15, 17.5, 20, 25  
MODEL SIZES 18, 21, 25, 29



## Product Data

**LEGACY™**  
**LINE**



C10538



# TABLE OF CONTENTS

	PAGE		PAGE
FEATURES AND BENEFITS .....	3	APPLICATION/SELECTION DATA .....	22
MODEL NUMBER NOMENCLATURE .....	4	COOLING CAPACITIES .....	24
FACTORY OPTIONS & ACCESSORIES .....	5	STATIC PRESSURE ADDERS .....	32
AHRI RATING TABLE .....	8	DAMPER, BAROMETRIC RELIEF & PE PERF .....	33
MIN-MAX AIRFLOWS CLG & ELECT HEAT .....	8	FAN PERFORMANCE .....	34
SOUND PERFORMANCE .....	8	ELECTRICAL INFORMATION .....	38
PHYSICAL DATA .....	9	SEQUENCE OF OPERATION .....	52
DIMENSIONS .....	12	GUIDE SPECIFICATIONS .....	55
OPTIONS & ACCESSORIES WEIGHT ADDERS ...	22		



**Heating & Cooling Systems**

The 15 to 25 ton Legacy Line Bryant rooftop unit (RTU) was designed by customers for customers. With a newly designed cabinet that integrates “no-strip” screw collars, handled access panels, and more, we’ve made your unit easy to install, easy to maintain and easy to use and reliable.

### **Easy to install:**

These Legacy Line units are designed for dedicated factory supplied horizontal air flow duct configurations. No special field kits are required. Designed to fit on pre-installed curbs by other another manufacturer, these units also fit on past designed Bryant installed curbs with a new certified and authorized adapter curb. This cabinet design also integrates a large control box that gives you room to work and room to mount Bryant accessory controls.

### **Easy to maintain:**

Easy access handles by Bryant provide quick and easy access to all major, normally serviced components. Our “no-strip” screw system has superior holding power and guides screws into position while preventing the screw from stripping the unit’s metal. Take accurate pressure readings by reading condenser pressure with panels in place as compressors are strategically located to eliminate any air bypass.

### **Easy to use:**

The newly designed, central terminal board by Bryant puts all your connections and troubleshooting points in one convenient place, standard. Most low voltage connections are made to the same board and make it easy to find what you’re looking for and easy to access it. Bryant rooftops have high and low pressure switches, a filter drier, and 2-in (51mm) filters standard.

### **Reliable:**

Each unit comes with precision sized and tested scroll compressor that is internally protected from over temperature and pressures. In addition, each refrigerant circuit is further protected with a high pressure and low pressure switch as well as containing a liquid line filter drier. Each unit is factory tested prior to shipment to help ensure units operation once properly installed.

## FEATURES AND BENEFITS

- 2-stage cooling capacity with independent circuits and control.
- High performance copper tube / aluminum plate (RTPF) fin condenser and evaporator coils with optional coating.
- EER's up to 11.0
- IEER's up to 11.2 with single speed indoor fan motor and up to 12.9 with 2-speed/VFD indoor fan motor
- Dedicated horizontal air flow duct configuration models. No field kits required.
- Utility connections through the side or bottom. Bottom connections are also in an enclosed environment to help prevent water entry. Field supplied couplings are required.
- Standardized components and control box layout. Standardized components and controls make stocking parts and service easier.
- Scroll compressors on all units. This makes service, stocking parts, replacement, and trouble-shooting easier.
- Proven TXV refrigerant metering system.
- Easy-adjust, belt-drive motor available. Motor assembly also contains a fan belt break protection system on all models and reliable pillow block bearing system that allows lubrication thru front of the unit.
- Capable of thru-the-base electrical routing.
- Full range of electric heaters and single point electric kits – pre-engineered and approved for field installation.
- Single-point electrical connection.
- Sloped, composite drain pan sheds water; and won't rust.
- Standardized controls and control box layout. Standardized components and controls make stocking parts and service easier.
- Clean, large, easy to use control box.
- Color-coded wiring.
- Large, laminated wiring and power wiring drawings which are affixed to unit make troubleshooting easy.
- Single, central terminal board for test and wiring connections.
- Fast-access, handled, panels for easy access on normally accessed service panels.
- "No-strip" screw system guides screws into the panel and captures them tightly without stripping the screw, the panel, or the unit.
- Mechanical cooling (115°F to 35°F / 46°C to 2°C) standard on all models. Low ambient controller allows operation down to -20°F / -29°C.
- 2-in (51mm) disposable filters on all units, with 4-in (102mm) filter track - field installed.
- Refrigerant filter-drier on each circuit.
- High and low pressure switches. Added reliability with high pressure switch and low pressure switch.
- Many factory-installed options ranging from air management economizers, 2 position dampers, manual outdoor air dampers, plus convenience outlets, disconnect switch and smoke detectors.
- Factory-installed Perfect Humidity System.
- Standard Parts Warranty: 10 year aluminized heat exchanger, 5 year compressor, condenser coil, 1 year others.
- Optional 2-Speed Indoor Fan Motor System utilizes a Variable Frequency Drive (VFD) to automatically adjust the indoor fan motor speed between cooling stages. Available on 2-stage cooling models 18-29 with electromechanical controls or RTU Open.

# MODEL NUMBER NOMENCLATURE

Position:	1	2	3	4	5	6	7	8	9	10	11	12	13	14	15	16	17
Example:	5	5	8	J	E	1	8	D	0	0	0	A	5	A	0	A	A

**Unit Type**

558 - Cooling RTU with optional Electric Heat

**Model**

J - Puron® (R-410A) Refrigerant

**Voltage**

E = 460-3-60  
P = 208/230-3-60  
T = 575-3-60

**Cooling Tons**

18 - 15 tons  
21 - 17.5 tons  
25 - 20 tons  
29 - 25 tons

**Refrig. System/Gas Heat Options**

D = Two stage cooling model  
K = Two stage cooling with Perfect Humidity™

**Heat Level**

(Field installed electric heaters available)  
000 = No Heat

**Coil Options (RTPF) (Outdoor - Indoor - Hail Guard)**

A = Al/Cu - Al/Cu  
B = Precoat Al/Cu - Al/Cu  
C = E-coat Al/Cu - Al/Cu  
D = E-coat Al/Cu - E-coat Al/Cu  
E = Cu/Cu - Al/Cu  
F = Cu/Cu - Cu/Cu  
M = Al/Cu - Al/Cu — Louvered Hail Guard  
N = Precoat Al/Cu - Al/Cu — Louvered Hail Guard  
P = E-coat Al/Cu - Al/Cu — Louvered Hail Guard  
Q = E-coat Al/Cu - E-coat Al/Cu — Louvered Hail Guard  
R = Cu/Cu - Al/Cu — Louvered Hail Guard  
S = Cu/Cu - Cu/Cu — Louvered Hail Guard

**Packaging & 2-Speed Indoor Fan Motor**

A = Standard Packaging  
D = Standard Packaging & 2-speed indoor fan motor (Standard on 29 size models)

**Factory Installed Options**

0A = None

**NOTE:** See the 558J Horizontal Models 15 to 25 ton Price Pages for a complete list of factory installed options.

**Outdoor Air Options**

A = None  
B = Temperature Economizer w/ Barometric Relief  
E = Temperature Economizer w/ Barometric Relief and CO<sub>2</sub>  
H = Enthalpy Economizer w/ Barometric Relief  
L = Enthalpy Economizer w/ Barometric Relief and CO<sub>2</sub>  
P = Manual Outdoor Air Damper  
Q = 2 Position Damper  
U = Temp Ultra Low Leak Economizer w/ Baro Relief  
W = Enthalpy Ultra Low Leak Economizer w/ Baro Relief

**Indoor Fan Options**

5 = Standard Static/Horizontal Supply, Return Air Flow (except on size 29)  
6 = Medium Static/Horizontal Supply, Return Air Flow  
7 = High Static/Horizontal Supply, Return Air Flow  
F = Medium Static High Efficiency Motor/Horizontal Supply, Return Air Flow (Standard on 29 size models)  
G = High Static High Efficiency Motor/Horizontal Supply, Return Air Flow

**Fig. 1 - Model Number Nomenclature (Example)**

C13805

**Table 1 – FACTORY-INSTALLED OPTIONS AND FIELD-INSTALLED ACCESSORIES**

CATEGORY	ITEM	FACTORY INSTALLED OPTION	FIELD INSTALLED ACCESSORY
<b>Cabinet</b>	Hinged Access Panels	X	
<b>Coil Options</b>	Cu/Cu indoor & outdoor coils	X	
	E-coated indoor & outdoor coils	X	
	Pre-coated outdoor coils	X	
<b>Humidity Control</b>	Perfect Humidity System	X	
<b>Condenser Protection</b>	Condenser coil hail guard (louvered design)	X	X
<b>Controls</b>	Thermostats, temperature sensors, and subbases		X
	RTU Open protocol controller	X	
	Smoke detector (supply and/or return air)	X	X
	Time Guard II compressor delay control circuit		X
	Phase Monitor		X
<b>Economizers &amp; Outdoor Air Dampers</b>	EconoMi\$er IV (for electro-mechanical controlled RTUs)	X	X
	EconoMi\$er2 (for DDC controlled RTUs)	X	X
	Motorized 2 position outdoor-air damper	X	X
	Manual outdoor-air damper (25%)		X
	Barometric relief <sup>1</sup>	X	X
	Barometric hood (Horizontal economizer)		X
	Power exhaust		X
	Ultra Low Leak EconoMi\$er X (for 2-Speed Indoor Fan Motor System only 18 to 29 sizes with 2 stages of cooling), horizontal supply and return air only.	X	X
<b>Economizer Sensors &amp; IAQ Devices</b>	Single dry bulb temperature sensors <sup>2</sup>	X	X
	Differential dry bulb temperature sensors <sup>2</sup>		X
	Single enthalpy sensors <sup>2</sup>	X	X
	Differential enthalpy sensors <sup>2</sup>		X
	CO <sub>2</sub> sensor (wall, duct, or unit mounted) <sup>2</sup>	X	X
<b>Electric Heat</b>	Electric Resistance Heaters		X
	Single Point Kit		X
<b>Indoor Motor &amp; Drive</b>	Multiple motor and drive packages	X	
	2-Speed Indoor Fan Motor System w/VFD controller (2-stage cool only with electrical mechanical and RTU Open controls)	X	
	Display Kit for 2-Speed Indoor Fan Motor System with VFD		X
<b>Low Ambient Control</b>	Winter start kit <sup>3</sup>		X
	MotorMaster head pressure controller to -20°F (-29°C) <sup>3</sup>		X
<b>Power Options</b>	Convenience outlet (powered)	X	
	Convenience outlet (unpowered)	X	
	Non-fused disconnect <sup>4</sup>	X	
<b>Roof Curbs</b>	Roof curb 14-in (356mm)		X
	Roof curb 24-in (610mm)		X

**NOTES:**

1. Included with economizer.
2. Sensors for optimizing economizer.
3. See application data for assistance.
4. Non-fused disconnect switch cannot be used when FLA electrical rating exceeds 100 amps at 460/575 volt and 200 amps at 208/230 volt. Bryant RTUBuilder selects this automatically.

# FACTORY OPTIONS AND/OR ACCESSORIES

## **Economizer (dry-bulb or enthalpy)**

Economizers save money. They bring in fresh, outside air for ventilation; and provide cool, outside air to cool your building. This is the preferred method of low-ambient cooling. When coupled to CO<sub>2</sub> sensors, Economizers can provide even more savings by coupling the ventilation air to only that amount required.

Economizers are available, installed and tested by the factory, with either enthalpy or dry-bulb temperature inputs. There are also models for electromechanical as well as direct digital controllers. Additional sensors are available as accessories to optimize the economizers.

Economizers include gravity controlled, barometric relief equalizes building pressure and ambient air pressures. This can be a cost effective solution to prevent building pressurization. If further control of exhaust air is required, a dual centrifugal fan power exhaust system is also available.

## **CO<sub>2</sub> Sensor**

Improves productivity and saves money by working with the economizer to intake only the correct amount of outside air for ventilation. As occupants fill your building, the CO<sub>2</sub> sensor detects their presence through increasing CO<sub>2</sub> levels, and opens the economizer appropriately.

When the occupants leave, the CO<sub>2</sub> levels decrease, and the sensor appropriately closes the economizer. This intelligent control of the ventilation air, called Demand Control Ventilation (DCV) reduces the overall load on the rooftop, saving money.

## **Smoke Detectors**

Trust the experts. Smoke detectors make your application safer and your job easier. Bryant smoke detectors immediately shut down the rooftop unit when smoke is detected. They are available, installed by the factory, for supply air, return air, or both.

## **Louvered Hail Guards**

Sleek, louvered panels protect the condenser coil from hail damage, foreign objects, and incidental contact.

## **Convenience Outlet (powered or un-powered)**

Reduce service and/or installation costs by including a convenience outlet in your specification. Bryant will install this service feature at our factory. Provides a convenient, 15 amp, 115v GFCI receptacle with "Wet in Use" cover. The "powered" option allows the installer to power the outlet from the line side of the disconnect as required by code. The "unpowered" option is to be powered from a separate 115/120v power source.

## **Non-Fused Disconnect**

This OSHA-compliant, factory-installed, safety switch allows a service technician to locally secure power to the rooftop.

## **Power Exhaust with Barometric Relief**

Superior internal building pressure control. This field-installed accessory or factory-installed option may eliminate the need for costly, external pressure control fans.

## **RTU Open Protocol Controller**

Connect the rooftop to an existing BAS without needing complicated translators or adapter modules using the RTU Open controller. This new controller speaks the 4 most common building automation system languages (Bacnet, Modbus, N2, and Lonworks). Use this controller when you have an existing BAS.

## **Time Guard II Control Circuit**

This accessory protects your compressor by preventing short-cycling in the event of some other failure, prevents the compressor from restarting for 30 seconds after stopping. Not required with PremierLink®, RTU Open, or authorized commercial thermostats.

## **Filter or Fan Status Switches**

Use these differential pressure switches to detect a filter clog or indoor fan motor failure. When used in conjunction with a compatible unit controller/thermostat, the switches will activate an alarm to warn the appropriate personnel.

## **Motorized 2-Position Damper**

The new Bryant 2-position, motorized outdoor air damper admits up to 100% outside air. Using reliable, gear-driven technology, the 2-position damper opens to allow ventilation air and closes when the rooftop stops, stopping unwanted infiltration.

## **Manual OA Damper**

Manual outdoor air dampers are an economical way to bring in ventilation air. The dampers are available in 25% versions.

## **Optional Perfect Humidity System**

Bryant's Perfect Humidity System is an all-inclusive factory installed option that can be ordered with any Legacy Line 558J 18-29 rooftop unit.

This system expands the envelope of operation of Bryant's Legacy Line rooftop products to provide unprecedented flexibility to meet year round comfort conditions.

The Perfect Humidity System has the industry's only dual dehumidification mode setting. The Perfect Humidity system includes two new modes of operation.

The Legacy Line 558J 18-29 rooftop coupled with the Perfect Humidity system is capable of operating in normal design cooling mode, subcooling mode, and hot gas reheat mode. Normal design cooling mode is when the unit will operate under its normal sequence of operation by cycling compressors to maintain comfort conditions.



## FACTORY OPTIONS AND/OR ACCESSORIES (cont.)

### Optional Perfect Humidity System (cont.)

Subcooling mode will operate to satisfy part load type conditions when the space requires combined sensible and a higher proportion of latent load control. Hot Gas Reheat mode will operate when outdoor temperatures diminish and the need for latent capacity is required for sole humidity control. Hot Gas Reheat mode will provide neutral air for maximum dehumidification operation.

### 2-Speed Indoor Fan Motor System

Bryant's 2-Speed Indoor Fan Motor System saves energy and installation time by utilizing a Variable Frequency Drive (VFD) to automatically adjust the indoor fan motor speed in sequence with the units cooling operation. Per ASHRAE 90.1 2010 standard section 6.4.3.10.b, during the first stage of cooling operation the VFD will adjust the fan motor to provide 2/3rd of the total cfm established for the unit. When a call for the second stage of cooling is required, the VFD will allow the total cfm for the unit established (100%). During the heating mode the VFD will allow total design cfm (100%) operation and during the ventilation mode the VFD will allow operation to 2/3rd of total cfm.

Compared to single speed indoor fan motor systems, Bryant's 2-Speed Indoor Fan Motor System can save substantial energy, 25%+\*, versus single speed indoor fan motor systems.

The VFD used in Bryant's 2-Speed Indoor Fan Motor System has soft start capabilities to slowly ramp up the speeds, thus eliminating any high inrush air volume during initial start-up. It also has internal over current protection for the fan motor and a field installed display kit that allows adjustment and in depth diagnostics of the VFD.

This 2-Speed Indoor Fan Motor System is available on models with 2-stage cooling operation with electrical mechanical or RTU Open, Multi Protocol controls. Both space sensor and conventional thermostats controls can be used to provide accurate control in any application.

The 2-Speed Indoor Fan Motor System is very flexible for initial fan performance set up and adjustment. The standard factory shipped VFD is pre-programmed to automatically stage the fan speed between the first and second stage of cooling. The unit fan performance static pressure and cfm can be easily adjusted using the traditional means of pulley adjustments. The other means to adjust the unit static and cfm performance is to utilize the field installed Display Kit and adjust the frequency and voltage in the VFD to required performance requirements. In either case, once set up, the VFD will automatically adjust the speed between the cooling stage operations.

\*Data based on .10 (\$/kWh) in an office application utilizing Bryant's HAP 4.6 simulation software program.

### Motormaster Head Pressure Controller

The Motormaster motor controller is a low ambient, head pressure controller kit that is designed to maintain the unit's condenser head pressure during periods of low ambient cooling operation. This device should be used as an alternative to economizer free cooling not when economizer usage is either not appropriate or desired. The Motormaster will either cycle the outdoor-fan motors or operate them at reduced speed to maintain the unit operation, depending on the model.

Motormaster allows cooling operation down to -20°F (-29°C) ambient conditions.

### Winter Start Kit

The winter start kit by Bryant extends the low ambient limit of your rooftop to 25°F (-4°C). The kit bypasses the low pressure switch, preventing nuisance tripping of the low pressure switch. Other low ambient precautions may still be prudent.

### Alternate Motors and Drives

Some applications need larger horsepower motors, some need more airflow, and some need both. Regardless of the case, your Bryant expert has a factory installed combination to meet your application. A wide selection of motors and pulleys (drives) are available, factory installed, to handle nearly any application.

### Thru-the-Base Connections

Thru-the-base provisions/connection points are available as standard with every unit. When bottom connections are required, field furnished couplings are required.

### Hinged Access Panels

Allows access to unit's major components with specifically designed hinged access panels. Panels are: filter, control box and fan motor.

### Electric Heaters / Single Point Kit

Bryant offers a full-line of field-installed accessory heaters and single point kits when required. The heaters are very easy to use, install and are all pre-engineered and certified.

### Barometric Hood

For Horizontal Economizer applications where relief damper is installed in duct work. This kit provides the needed protection.

**Table 2 – AHRI COOLING RATING TABLE 2-STAGE COOLING**

UNIT	COOLING STAGES	NOM. CAPACITY (TONS)	NET COOLING CAPACITY (MBH)	TOTAL POWER (kW)	EER	IEER WITH SINGLE SPEED INDOOR MOTOR	IEER WITH 2-SPEED INDOOR MOTOR
18	2	15	174.0	15.8	11.0	11.2	12.9
21	2	17.5	202.0	18.4	11.0	11.2	12.9
25	2	20	232.0	21.1	11.0	11.2	12.9
29	2	25	282.0	28.2	10.0	N/A*	11.2

**LEGEND**

- AHRI – Air Conditioning, Heating and Refrigeration Institute Test Standard
- ASHRAE – American Society of Heating, Refrigerating and Air Conditioning, Inc.
- EER – Energy Efficiency Ratio
- IEER – Integrated Energy Efficiency Ratio
- \* – Model only available with 2-Speed indoor Fan Motor



Use of the AHRI Certified TM Mark indicates a manufacturer's participation in the program For verification of certification for individual products, go to [www.ahridirectory.org](http://www.ahridirectory.org).



**NOTES**

1. Rated and certified under AHRI Standard 340/360, as appropriate.
2. Ratings are based on:  
**Cooling Standard:** 80°F (27°C) db, 67°F (19°C) wb indoor air temp and 95°F db outdoor air temp.  
**IEER Standard:** A measure that expresses cooling part-load EER efficiency for commercial unitary air conditioning and heat pump equipment on the basis of weighted operation at various load capacities.
3. All 558J units comply with ASHRAE 90.1 Energy Standard for minimum EER and IEER requirements.
4. Where appropriate, 558J units comply with US Energy Policy Act. Refer to state and local codes or visit the following website: <http://bcap-energy.org> to determine if compliance with this standard pertains to your state, territory, or municipality.

**Table 3 – MINIMUM - MAXIMUM AIRFLOWS (CFM) COOLING AND ELECTRIC HEAT**

Model Size	Nominal kW	COOLING				ELECTRIC HEATERS	
		Minimum Single Speed Fan Motor	Minimum 2-Speed Fan Motor (at high speed)	Minimum 2-Speed Fan Motor (at low speed)	Maximum	Minimum	Maximum
18	25	4500	5070	3346	7500	4500	7500
	50						
	75						
21	25	5250	5915	3904	9000	5200	9000
	50						
	75						
25	25	6000	7500	4950	10000	6000	10000
	50						
	75						
29	25	7500	8450	5577	12500	7000	12500
	50						
	75						

**Table 4 – SOUND PERFORMANCE TABLE**

MODEL SIZE	CLG STAGES	OUTDOOR SOUND (dB)									
		A-Wgt	AHRI 370 Rating	63	125	250	500	1000	2000	4000	8000
18	2	84.1	84	92.2	83.9	80.4	81.8	78.7	76.5	72.2	65.4
21	2	84.1	84	92.2	83.9	80.4	81.8	78.7	76.5	72.2	65.4
25	2	86.5	87	95.6	87.5	84.2	84.2	81.7	77.9	73.2	66.3
29	2	85.9	86	97.1	88.3	84.4	83.3	80.7	77.4	73.4	67.3

**LEGEND**

dB – Decibel

**NOTES:**

1. Outdoor sound data is measure in accordance with AHRI standard 270-2008.
2. Measurements are expressed in terms of sound power. Do not compare these values to sound pressure values because sound pressure depends on specific environmental factors which normally do not match individual applications. Sound power values are independent of the environment and therefore more accurate.
3. A-weighted sound ratings filter out very high and very low frequencies, to better approximate the response of "average" human ear. A-weighted measurements for Bryant units are taken in accordance with AHRI standard 270-2008.





**Table 5 – PHYSICAL DATA  
RTPF (Round Tube/Plate Fin Coil Design)**

**(COOLING)**

**15-25 TONS**

		<b>558J*18D</b>	<b>558J*18K</b>	<b>558J*21D</b>	<b>558J*21K</b>
<b>Refrigeration System</b>					
# Circuits / # Comp. / Type		2 / 2 / Scroll	2 / 2 / Scroll	2 / 2 / Scroll	2 / 2 / Scroll
R-410a charge A/B (lbs)		17/16.4	24.5/25.7	17.5/16.8	25.5/25.5
Metering device		TXV	TXV	TXV	TXV
High–press. Trip / Reset (psig)		630 / 505	630 / 505	630 / 505	630 / 505
Low–press. Trip / Reset (psig)		54 / 117	27 / 44	54 / 117	27 / 44
Material		Cu / Al	Cu / Al	Cu / Al	Cu / Al
Tube Diameter		3/8" RTPF	3/8" RTPF	3/8" RTPF	3/8" RTPF
Rows / FPI		4 / 15	4 / 15	4 / 15	4 / 15
total face area (ft2)		22	22	22	22
Condensate drain conn. size		3/4"	3/4"	3/4"	3/4"
<b>Perfect Humidity Coil</b>					
Material		n/a	Cu / Al	n/a	Cu / Al
Tube Diameter		n/a	3/8" RTPF	n/a	3/8" RTPF
Rows / FPI		n/a	1 / 17	n/a	1 / 17
total face area (ft2)		n/a	22	n/a	22
<b>Evap. fan and motor</b>					
Standard Static	Motor Qty / Belt Qty / Driver Type	1/1/ Belt	1/1/ Belt	1/1/ Belt	1/1/ Belt
	Max BHP	2.2	2.2	3.3	3.3
	RPM range	514–680	514–680	622–822	622–822
	motor frame size	56	56	56	56
	Fan Qty / Type	2 / Centrifugal	2 / Centrifugal	2 / Centrifugal	2 / Centrifugal
	Fan Diameter (in)	18 x 15/15 X 11	18 x 15/15 X 11	18 x 15/15 X 11	18 x 15/15 X 11
Medium Static	Motor Qty / Belt Qty / Driver Type	1/1/ Belt	1/1/ Belt	1/1/ Belt	1/1/ Belt
	Max BHP	3.3	3.3	4.9	4.9
	RPM range	614–780	614–780	713–879	713–879
	motor frame size	56	56	56	56
	Fan Qty / Type	2 / Centrifugal	2 / Centrifugal	2 / Centrifugal	2 / Centrifugal
	Fan Diameter (in)	18 x 15/15 X 11	18 x 15/15 X 11	18 x 15/15 X 11	18 x 15/15 X 11
High Static	Motor Qty / Belt Qty / Driver Type	1/1/ Belt	1/1/ Belt	n/a	n/a
	Max BHP	4.9	4.9	n/a	n/a
	RPM range	746–912	746–912	n/a	n/a
	motor frame size	56	56	n/a	n/a
	Fan Qty / Type	2 / Centrifugal	2 / Centrifugal	n/a	n/a
	Fan Diameter (in)	18 x 15/15 X 11	18 x 15/15 X 11	n/a	n/a
High Static– High Eff	Motor Qty / Belt Qty / Driver Type	n/a	n/a	1/1/ Belt	1/1/ Belt
	Max BHP	n/a	n/a	6.5/ 6.9/ 7.0/ 8.3	6.5/ 6.9/ 7.0/ 8.3
	RPM range	n/a	n/a	882–1078	882–1078
	motor frame size	n/a	n/a	184T	184T
	Fan Qty / Type	n/a	n/a	2 / Centrifugal	2 / Centrifugal
	Fan Diameter (in)	n/a	n/a	18 x 15/15 X 11	18 x 15/15 X 11

**Table 5 PHYSICAL DATA (cont.)  
RTPF (Round Tube/Plate Fin Coil Design)**

**(COOLING)**

**15-25 TONS**

		<b>558J*25D</b>	<b>558J*25K</b>	<b>558J*29D</b>	<b>558J*29K</b>
<b>Refrigeration System</b>					
	# Circuits / # Comp. / Type	2 / 2 / Scroll	2 / 2 / Scroll	2 / 2 / Scroll	2 / 2 / Scroll
	R-410a charge A/B (lbs)	23.8/23.1	30.0/30.7	24.9/27.7	35.1/35.4
	Metering device	TXV	TXV	TXV	TXV
	High-press. Trip / Reset (psig)	630 / 505	630 / 505	630 / 505	630 / 505
	Low-press. Trip / Reset (psig)	54 / 117	27 / 44	54 / 117	27 / 44
	Material	Cu / Al	Cu / Al	Cu / Al	Cu / Al
	Tube Diameter	3/8" RTPF	3/8" RTPF	3/8" RTPF	3/8" RTPF
	Rows / FPI	4 / 15	4 / 15	4 / 15	4 / 15
	total face area (ft2)	26	26	26	26
	Condensate drain conn. size	3/4"	3/4"	3/4"	3/4"
<b>Perfect Humidity Coil</b>					
	Material	n/a	Cu / Al	n/a	Cu / Al
	Tube Diameter	n/a	3/8" RTPF	n/a	3/8" RTPF
	Rows / FPI	n/a	1 / 17	n/a	1 / 17
	total face area (ft2)	n/a	26	n/a	26
<b>Evap. fan and motor</b>					
Standard Static	Motor Qty / Belt Qty / Driver Type	1/1/ Belt	1/1/ Belt	1/1/ Belt	1/1/ Belt
	Max BHP	4.9	4.9	4.9	4.9
	RPM range	690-863	690-863	647-791	647-791
	motor frame size	56	56	56	56
	Fan Qty / Type	2 / Centrifugal	2 / Centrifugal	2 / Centrifugal	2 / Centrifugal
	Fan Diameter (in)	18 x 15/15 X 11	18 x 15/15 X 11	18 x 15/15 X 11	18 x 15/15 X 11
Medium Static - High Eff.	Motor Qty / Belt Qty / Driver Type	1/1/ Belt	1/1/ Belt	1/1/ Belt	1/1/ Belt
	Max BHP	6.5/ 6.9/ 7.0/ 8.3	6.5/ 6.9/ 7.0/ 8.3	6.5/ 6.9/ 7.0/ 8.3	6.5/ 6.9/ 7.0/ 8.3
	RPM range	835-1021	835-1021	814-1009	814-1009
	motor frame size	184T	184T	184T	184T
	Fan Qty / Type	2 / Centrifugal	2 / Centrifugal	2 / Centrifugal	2 / Centrifugal
	Fan Diameter (in)	18 x 15/15 X 11	18 x 15/15 X 11	18 x 15/15 X 11	18 x 15/15 X 11
High Static- High Eff.	Motor Qty / Belt Qty / Driver Type	1/1/ Belt	1/1/ Belt	1/1/ Belt	1/1/ Belt
	Max BHP	10.5/11.9/11.9/11	10.5/11.9/11.9/11	10.5/11.9/11.9/11	10.5/11.9/11.9/11
	RPM range	941-1176	941-1176	965-1171	965-1171
	motor frame size	213T	213T	213T	213T
	Fan Qty / Type	2 / Centrifugal	2 / Centrifugal	2 / Centrifugal	2 / Centrifugal
	Fan Diameter (in)	18 x 15/15 X 11	18 x 15/15 X 11	18 x 15/15 X 11	18 x 15/15 X 11

**Table 5 PHYSICAL DATA (cont.)  
RTPF (Round Tube/Plate Fin Coil Design)**

**(COOLING)**

**15-25 TONS**

	558J*18D	558J*18K	558J*21D	558J*21K	558J*25D	558J*25K	558J*29D	558J*29K
<b>Cond. Coil (Circuit A)</b>								
Coil type	RTPF	RTPF	RTPF	RTPF	RTPF	RTPF	RTPF	RTPF
Coil Length (in)	70	70	72	72	82	82	95	95
Coil Height (in)	44	44	44	44	52	52	52	52
Rows / FPI	2 /17	2 /17	2 /17	2 /17	2 /17	2 /17	2 /17	2 /17
total face area (ft2)	21.4	21.4	22.0	22.0	29.6	29.6	34.3	34.3
<b>Cond. Coil (Circuit B)</b>								
Coil type	RTPF	RTPF	RTPF	RTPF	RTPF	RTPF	RTPF	RTPF
Coil Length (in)	70	70	64	64	80	80	95	95
Coil Height (in)	44	44	44	44	52	52	52	52
Rows / FPI	2 /17	2 /17	2 /17	2 /17	2 /17	2 /17	2 /17	2 /17
total face area (ft2)	21.4	21.4	19.5	19.5	29.6	29.6	34.3	34.3
<b>Cond. fan / motor</b>								
Qty / Motor drive type	3 / direct	3 / direct	4 / direct	4 / direct	4/ direct	4/ direct	6 / direct	6 / direct
Motor HP / RPM	1/4 / 1100	1/4 / 1100	1/4 / 1100	1/4 / 1100	1/4 / 1100	1/4 / 1100	1/4 / 1100	1/4 / 1100
Fan diameter (in)	22	22	22	22	22	22	22	22
<b>Filters</b>								
RA Filter # / size (in)	6 / 20 x 25 x 2	6 / 20 x 25 x 2	6 / 20 x 25 x 2	6 / 20 x 25 x 2	9 / 16 x 25 x 2	9 / 16 x 25 x 2	9 / 16 x 25 x 2	9 / 16 x 25 x 2
OA inlet screen # / size (in)	4 / 16 x 25 x 1	4 / 16 x 25 x 1	4 / 16 x 25 x 1	4 / 16 x 25 x 1	4 / 16 x 25 x 1	4 / 16 x 25 x 1	4 / 16 x 25 x 1	4 / 16 x 25 x 1



# DIMENSIONS

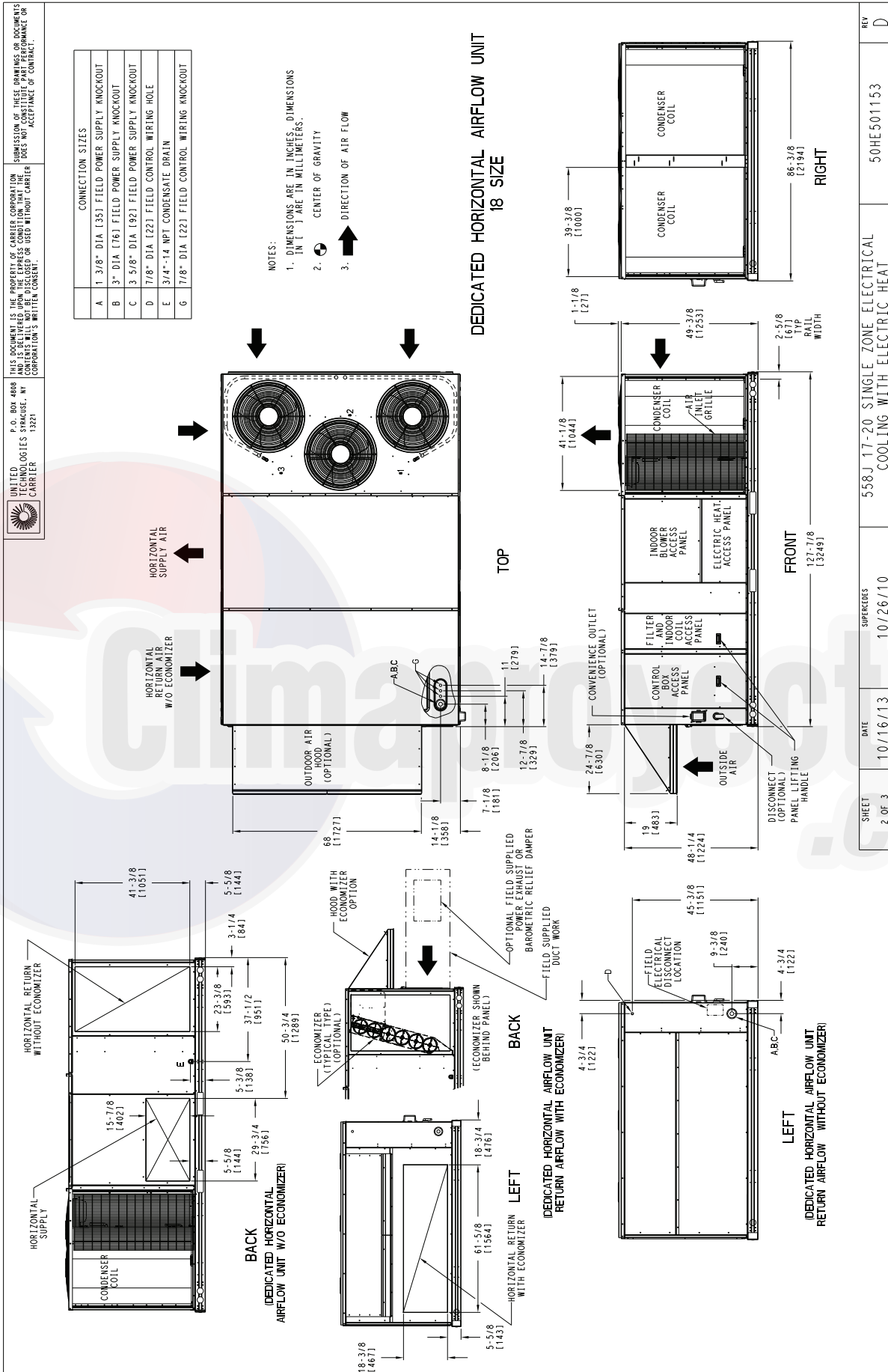

**Fig. 2 - Unit Dimensional Drawing – 18 Size Unit**

# DIMENSIONS (cont.)

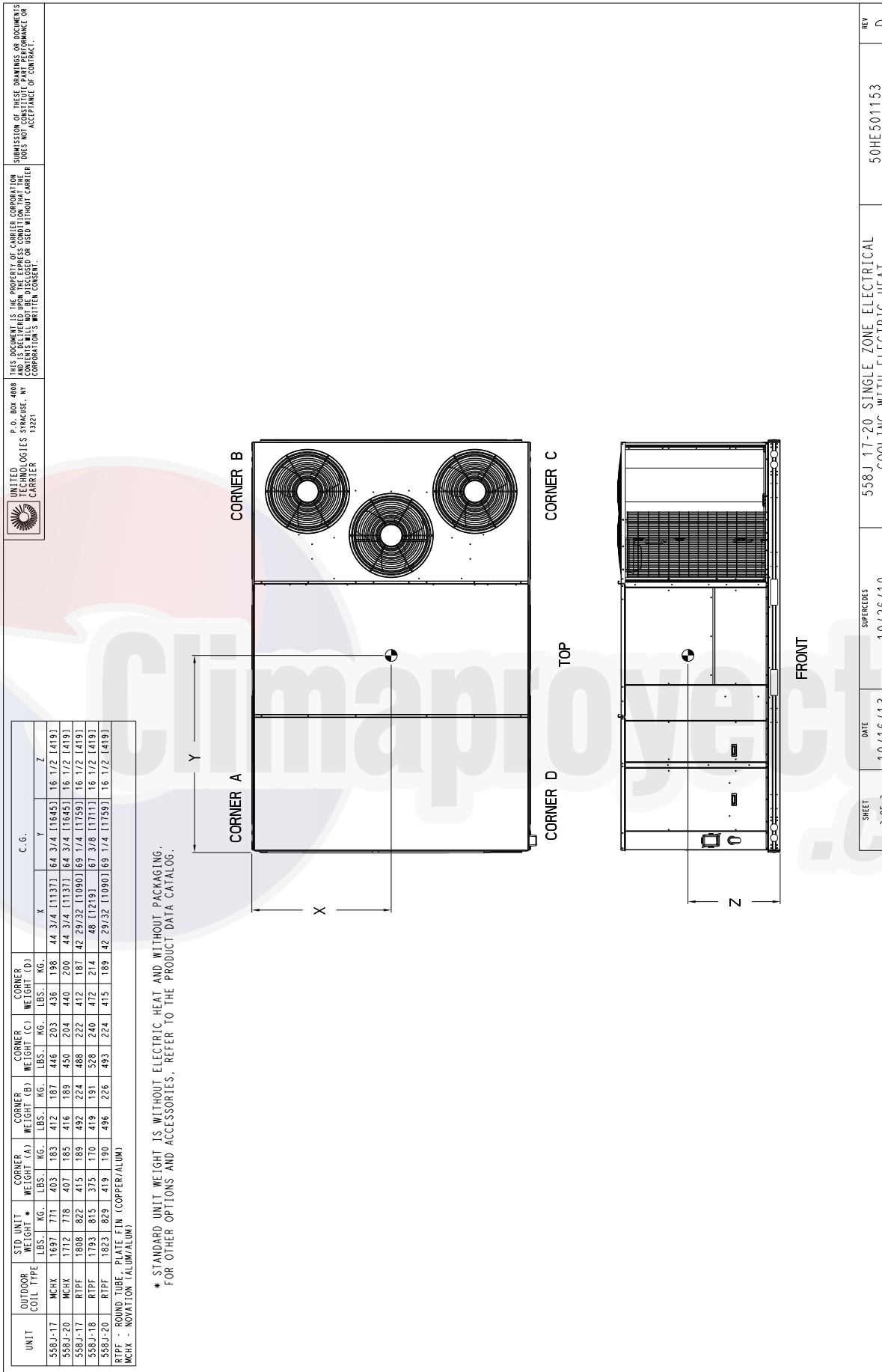

**Fig. 2 - Unit Dimensional Drawing – 18 Size Unit (cont.)**

# DIMENSIONS (cont.)

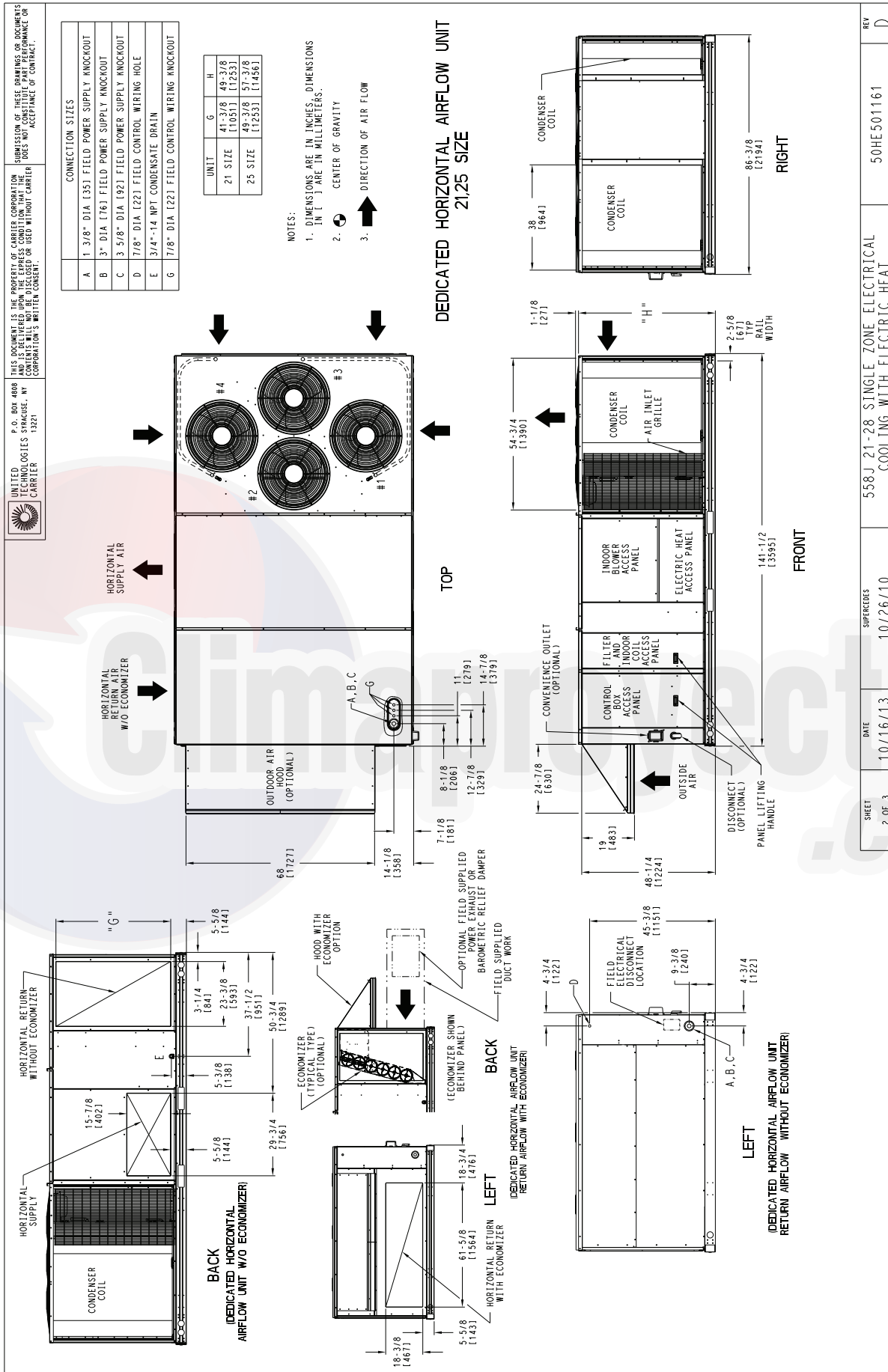

SHEET 2 OF 3

DATE 10/16/13

SUPERSEDES 10/26/10

REV D

**Fig. 3 - Unit Dimensional Drawing – 21 and 25 Size Units**



# DIMENSIONS (cont.)

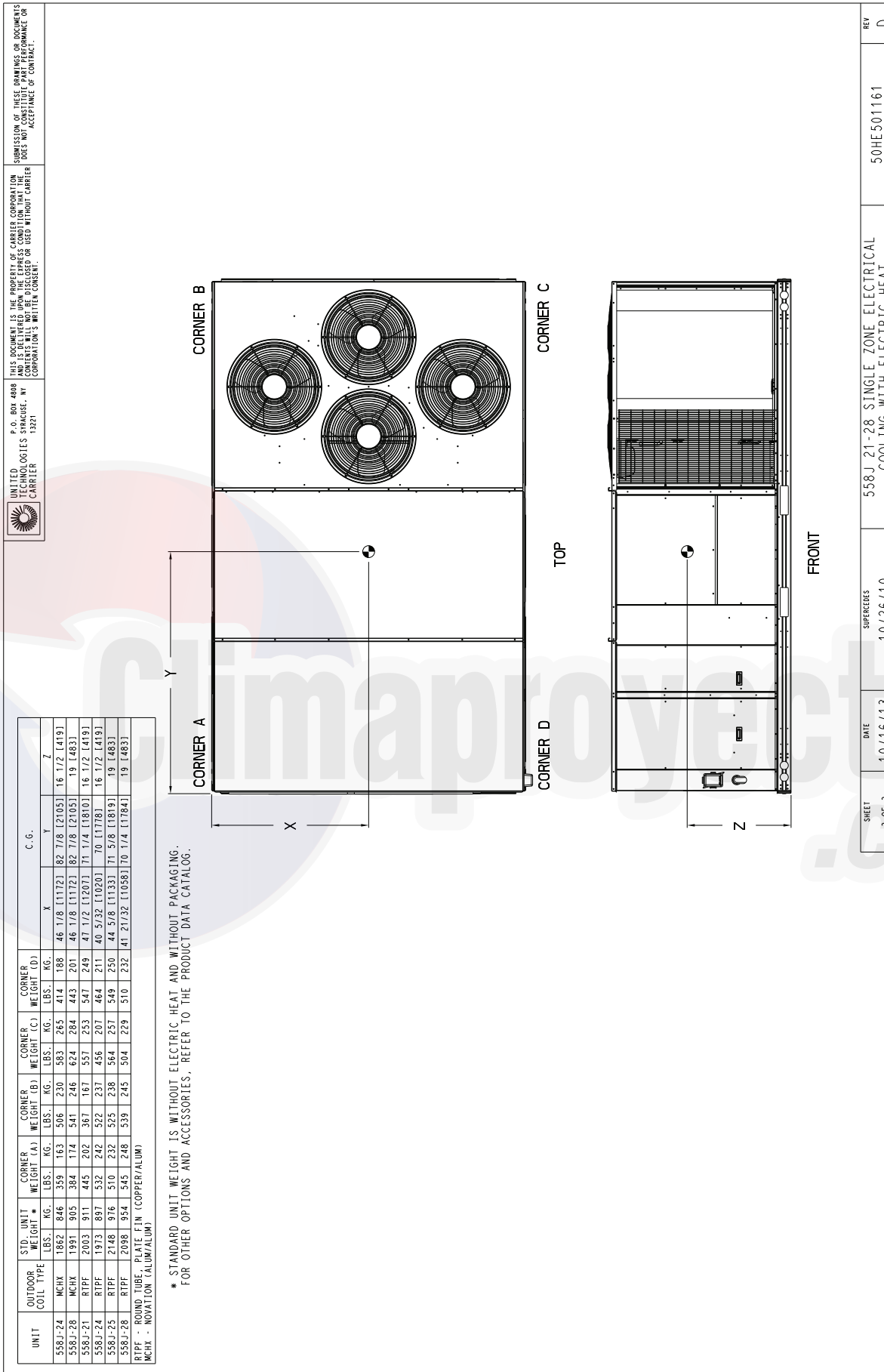

**Fig. 3 - Unit Dimensional Drawing – 21 and 25 Size Units (cont.)**

# DIMENSIONS (cont.)

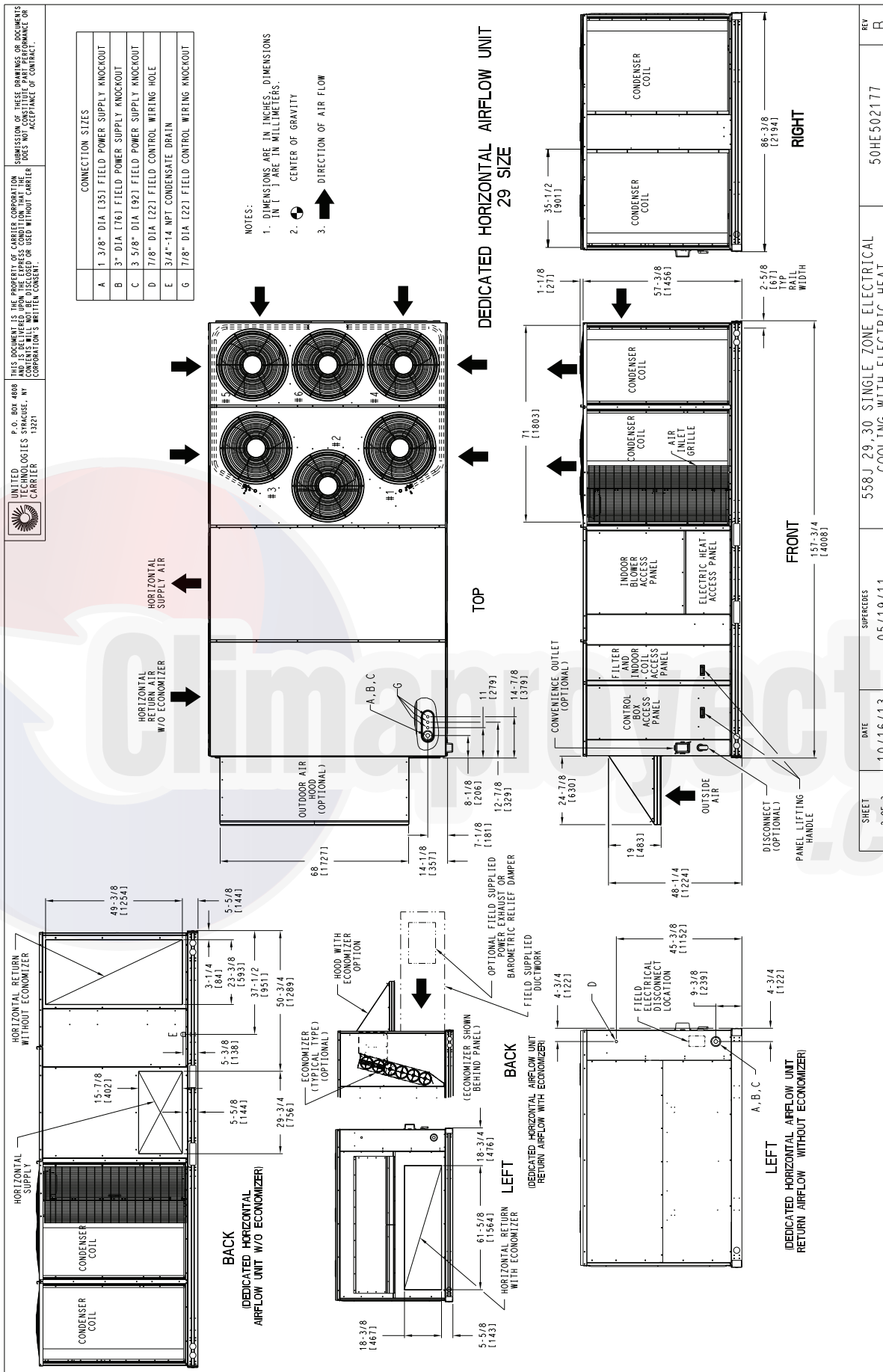

SHEET 2 OF 3	DATE 10/16/13	SUPERSEDES 05/19/11	558J 29_30 SINGLE ZONE ELECTRICAL COOLING WITH ELECTRIC HEAT	REV B
--------------	---------------	---------------------	--	-------

**Fig. 4 - Unit Dimensional Drawing – 29 Size Unit**

# DIMENSIONS (cont.)

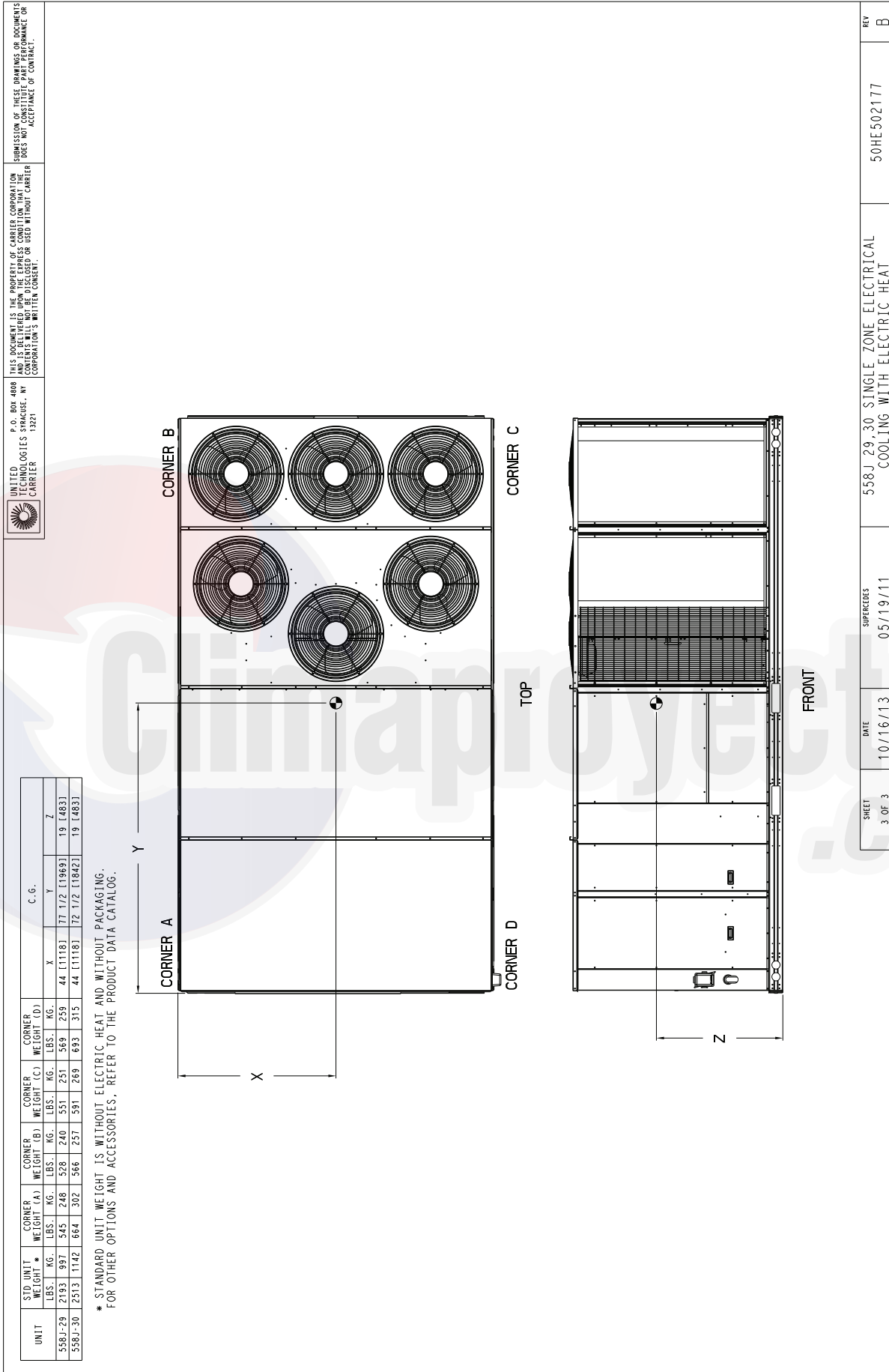

**Fig. 4 - Unit Dimensional Drawing – 29 Size Unit (cont.)**

## DIMENSIONS (cont.)

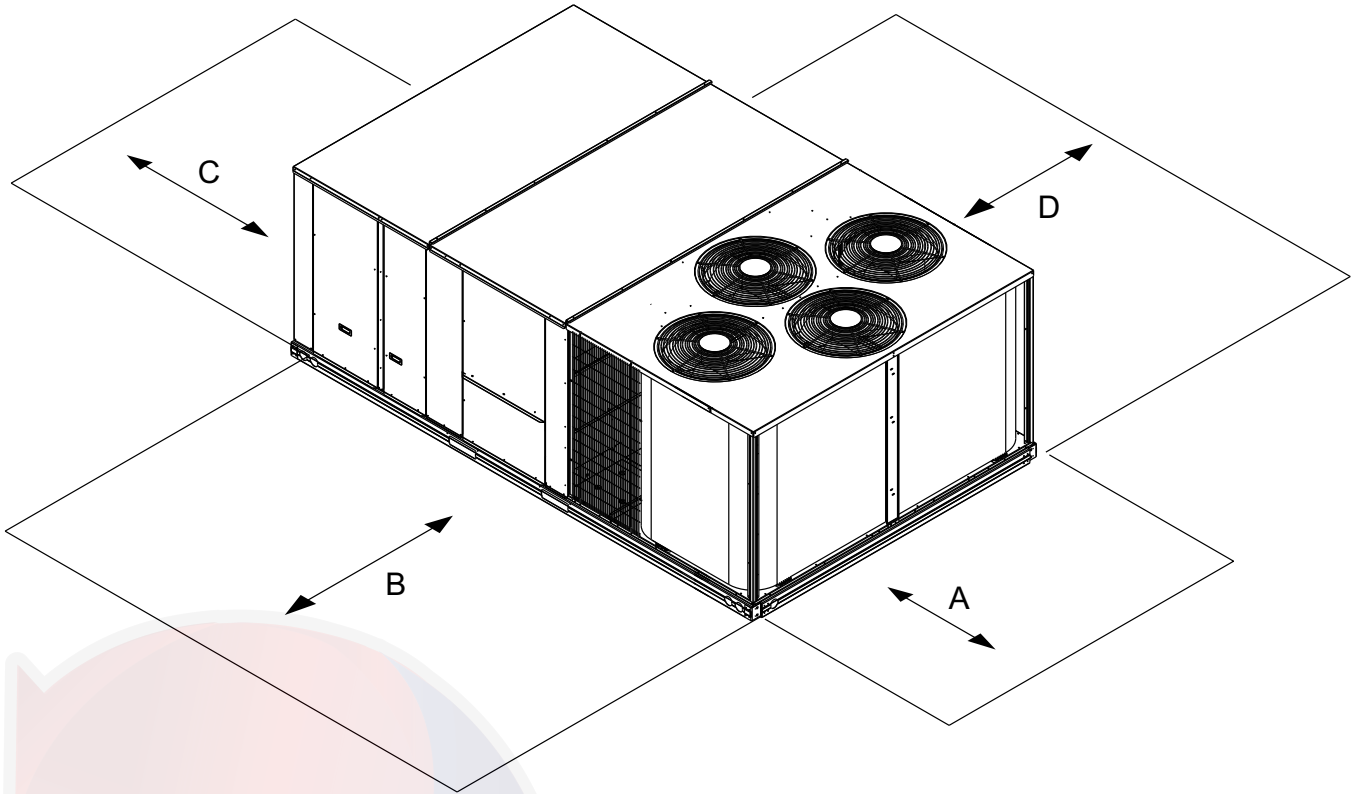

C12392

LOCATION	DIMENSION	CONDITION
A	36-in (914 mm)	<ul style="list-style-type: none"> <li>Recommended clearance for air flow and service</li> </ul>
B	42-in (1067 mm)	<ul style="list-style-type: none"> <li>Recommended clearance for air flow and service</li> </ul>
C	18-in (457 mm)	<ul style="list-style-type: none"> <li>No Convenience Outlet</li> <li>No Economizer</li> <li>No field installed disconnect on economizer hood side (Factory – installed disconnect installed).</li> </ul>
	36-in (914 mm)	<ul style="list-style-type: none"> <li>Convenience Outlet installed.</li> <li>Vertical surface behind servicer is electrically non-conductive (e.g.: wood, fiberglass).</li> </ul>
	42-in (1067 mm)	<ul style="list-style-type: none"> <li>Convenience Outlet installed.</li> <li>Vertical surface behind servicer is electrically conductive (e.g.: metal, masonry).</li> </ul>
	96-in (2438 mm)	<ul style="list-style-type: none"> <li>Economizer and/or Power Exhaust installed.</li> <li>Check for sources of flue products with 10 feet (3 meters) of economizer fresh air intake.</li> </ul>
D	42-in (1067 mm)	<ul style="list-style-type: none"> <li>Recommended clearance for service.</li> </ul>

**NOTE:** Unit not designed to have overhead obstruction. Contact Application Engineering for guidance on any application planning overhead obstruction or for vertical clearances.

**Fig. 5 - Service Clearance Dimensional Drawing**

**Table 6 – Operating Weights**

558J*	UNIT LB (KG)			
	18	21	25	29
Base Unit	1793 (815)	2003 (911)	2148 (976)	2193 (997)
Economizer	246 (112)	246 (112)	246 (112)	246 (112)
Powered Outlet	35 (16)	35 (16)	35 (16)	35 (16)
Perfect Humidity System	110 (50)	120 (54)	120 (54)	120 (54)
Curb				
14-in/356 mm	240 (109)	255 (116)	255 (116)	255 (116)
24-in/610 mm	340 (154)	355 (161)	355 (161)	355 (161)

# DIMENSIONS (cont.)

UNIT SIZE	"A"	ROOF CURB ACCESSORY
18	1'-2" [356.0] 2'-0" [610.0]	CRRFCURB045A00 CRRFCURB046A00

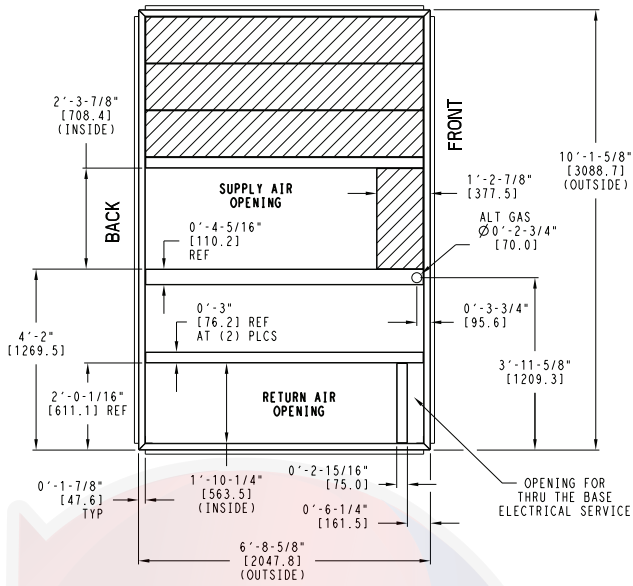

NOTES:

- 1 ROOF CURB ACCESSORY IS SHIPPED UNASSEMBLED.
- 2 DIMENSIONS IN ( ) ARE IN MILLIMETERS.
- 3 ROOF CURB GALVANIZED STEEL.
- 4 ATTACH DUCTWORK TO CURB (FLANGES ON DUCT REST ON CURB)
- 5 SERVICE CLEARANCE 4 FT ON EACH SIDE

➔ DIRECTION OF AIR FLOW

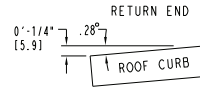
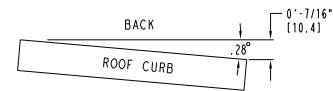

MAX CURB LEVELING TOLERANCES

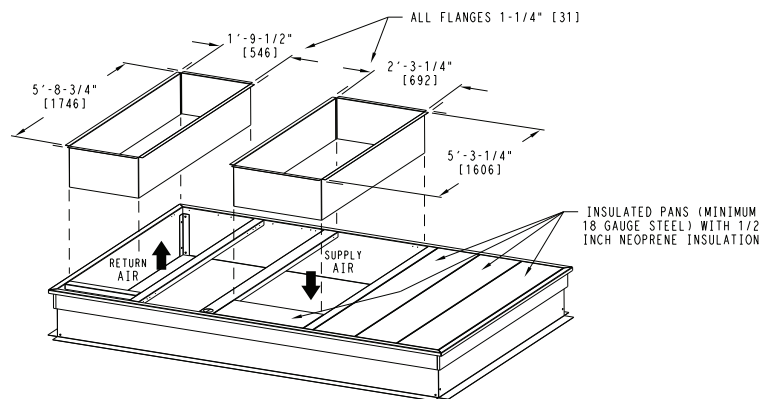
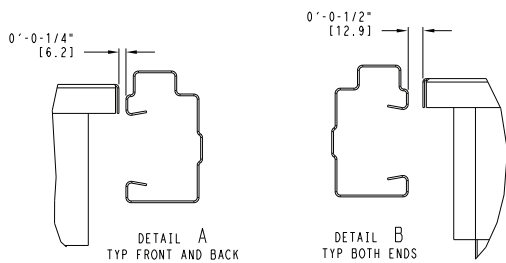
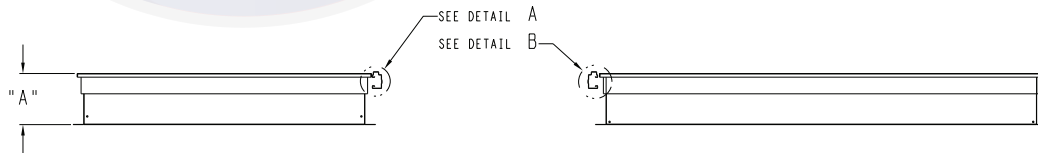
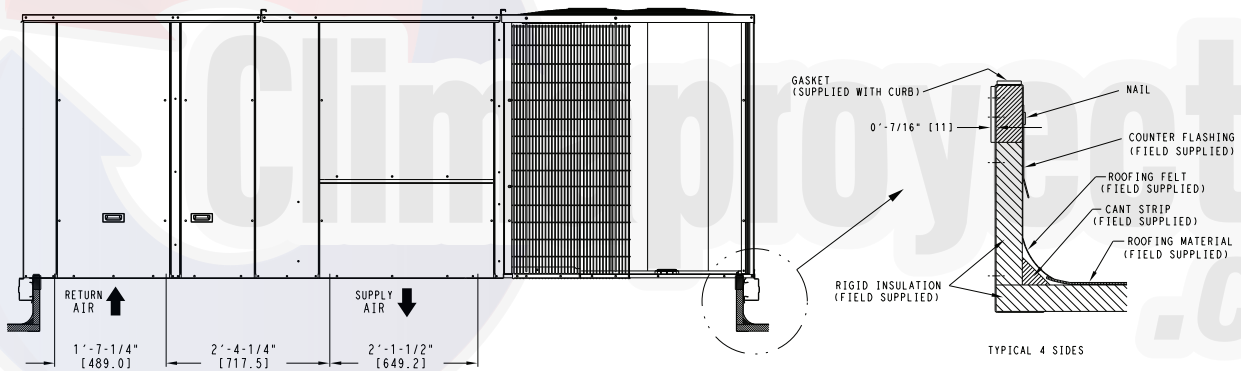
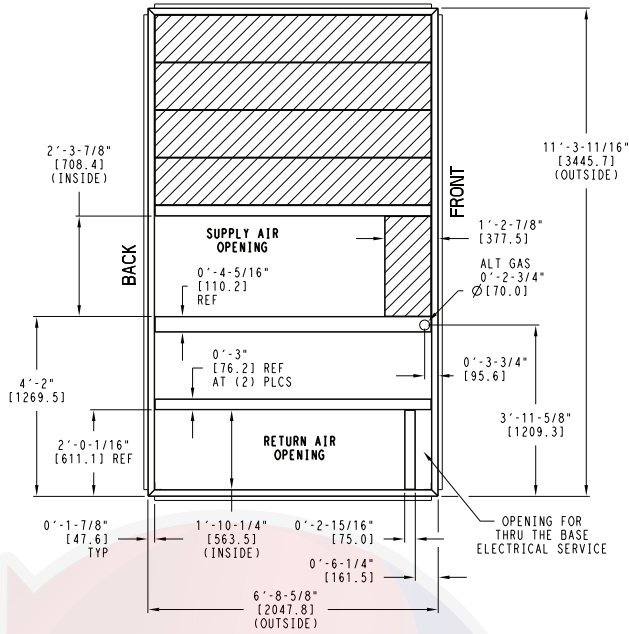

Fig. 6 - Roof Curb Details - 18 Size Unit

# DIMENSIONS (cont.)

UNIT SIZE	"A"	ROOF CURB ACCESSORY
21,25	1'-2" [356.0] 2'-0" [610.0]	CRRFCURB047A00 CRRFCURB048A00



**NOTES:**

- 1 ROOF CURB ACCESSORY IS SHIPPED UNASSEMBLED.
- 2 DIMENSIONS IN [ ] ARE IN MILLIMETERS.
- 3 ROOF CURB GALVANIZED STEEL.
- 4 ATTACH DUCTWORK TO CURB (FLANGES ON DUCT REST ON CURB)
- 5 SERVICE CLEARANCE 4 ft ON EACH SIDE

➔ DIRECTION OF AIR FLOW

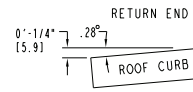
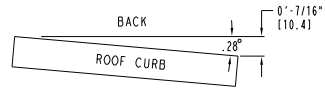

MAX CURB LEVELING TOLERANCES

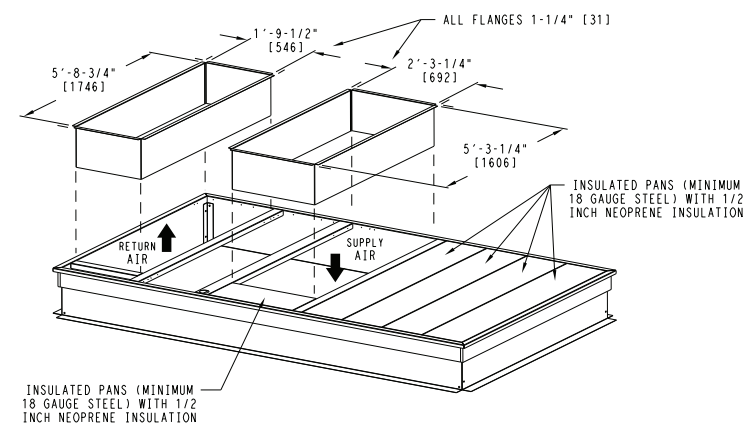
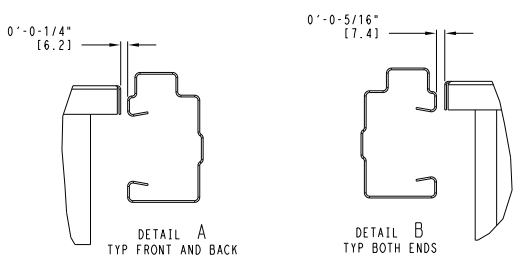
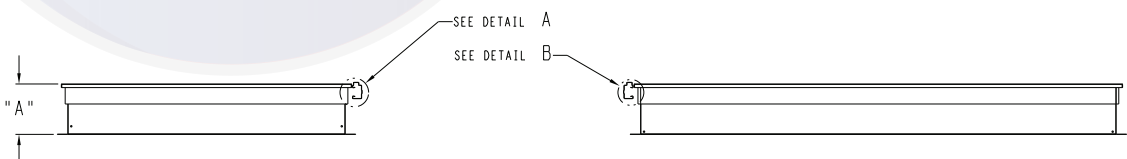
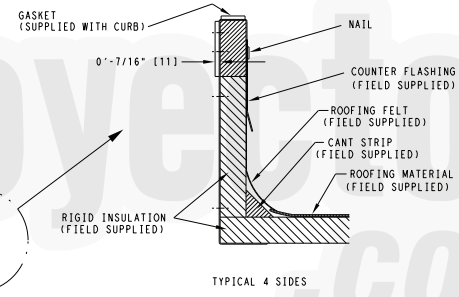
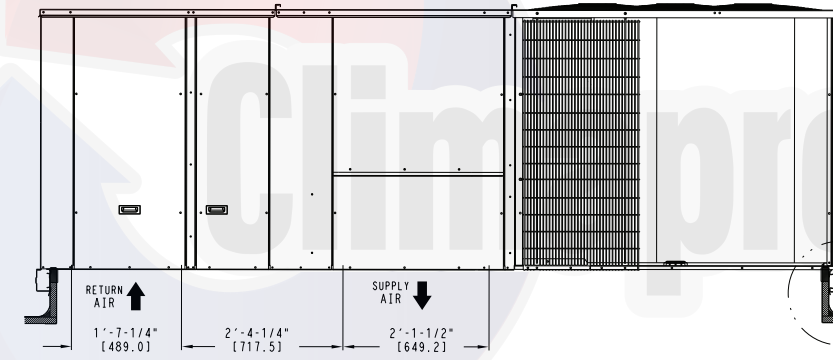

**Fig. 7 - Roof Curb Details – 21 and 25 Size Units**

C13781



# DIMENSIONS (cont.)

UNIT SIZE	"A"	ROOF CURB ACCESSORY
29	1'-2" [356.0] 2'-0" [610.0]	CRRFCURB049A00 CRRFCURB050A00

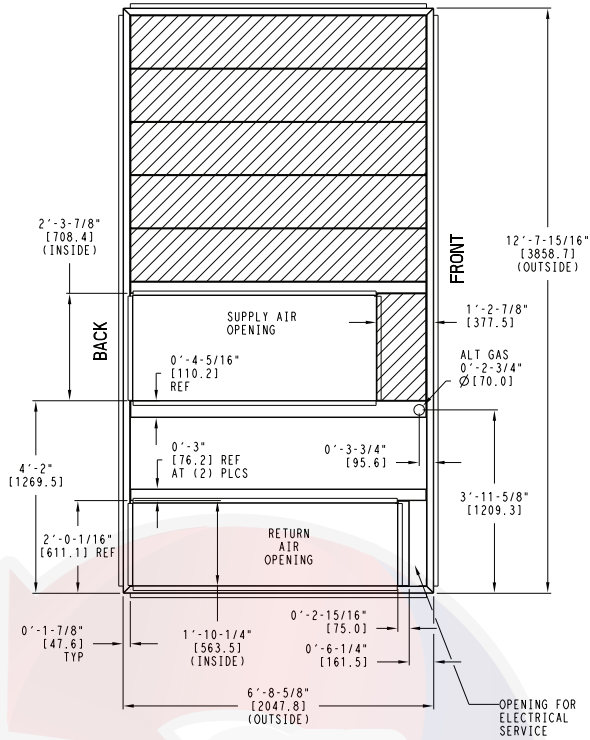

- NOTES:  
 1 ROOF CURB ACCESSORY IS SHIPPED UNASSEMBLED.  
 2 BOLT HEADS TO BE ON INSIDE OF FLANGE. CLEARANCE IS (1) 0'-0-7/16" TYP ALL CORNERS.  
 3 DIMENSIONS IN ( ) ARE IN MILLIMETERS.  
 4 ROOF CURB GALVANIZED STEEL.  
 5 ATTACH DUCTWORK TO CURB (FLANGES ON DUCT REST ON CURB)  
 6 SERVICE CLEARANCE 4 FT ON EACH SIDE  
 7 GAS SERVICE PLATE IS PART OF A SEPERATELY SHIPPED ACCESSORY PACKAGE.  
 8 GAS SERVICE PLATE CAN BE USED WITH EITHER ACCESSORY ROOFCURB.

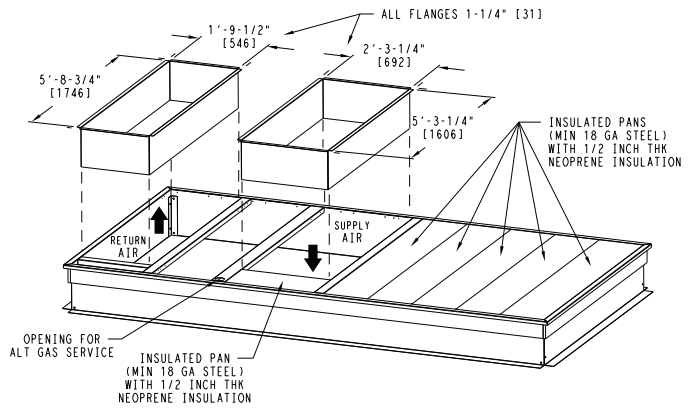
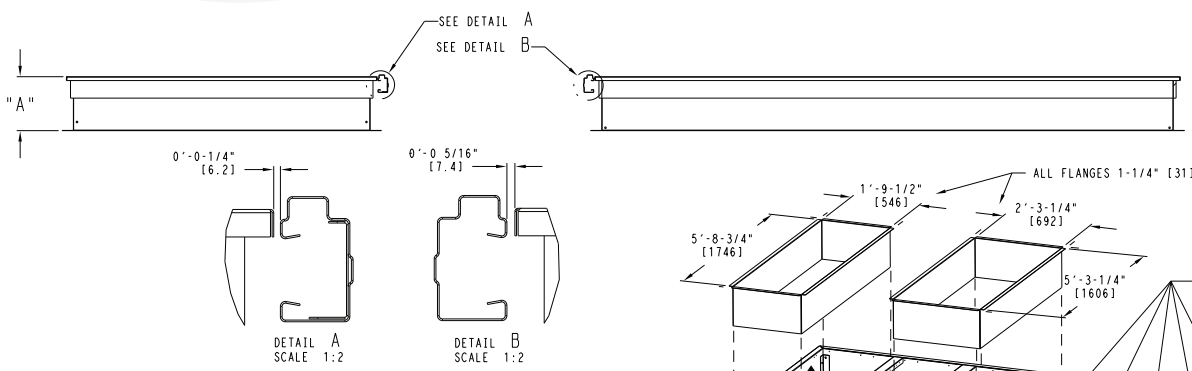
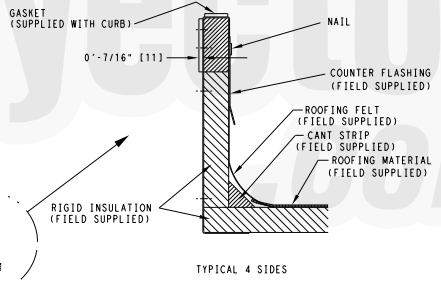
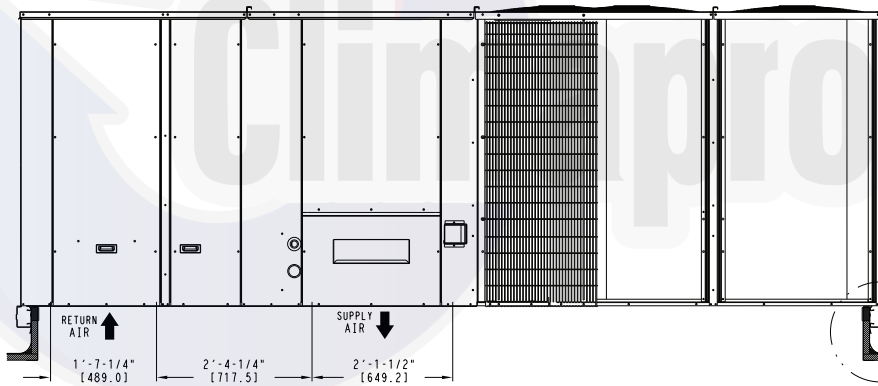
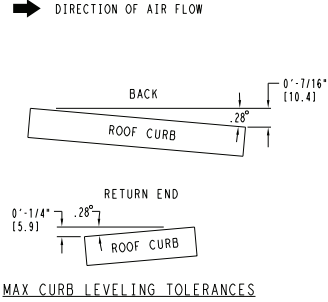

**Fig. 8 - Roof Curb Details – 29 Size Unit**

C13782

## OPTIONS AND ACCESSORIES WEIGHT ADDERS

BASE UNIT WITH OPTIONS AND ACCESSORIES (Weight Adders)	MAX WEIGHT ADD							
	558J*18		558J*21		558J*25		558J*29	
	lb	kg	lb	kg	lb	kg	lb	kg
Perfect Humidity*	110	50	120	55	120	55	120	55
Base Unit Operating Weight	1793	813	2003	909	2148	974	2193	975
Power Exhaust	125	57	125	57	125	57	125	57
Economizer	246	112	246	112	246	112	246	112
Copper Tube/Fin Evaporator Coil	53	24	58	26	64	29	64	29
Electric Heater	85	39	85	39	85	39	85	39
Single Point Kit	15	7	15	7	15	7	15	7
Roof Curb 14-in (356mm)	240	109	255	116	255	116	255	116
Roof Curb 24-in (610mm)	340	154	355	161	355	161	355	161
Louvered Hail Guard	60	27	60	27	120	54	150	68
CO <sub>2</sub> sensor	5	2	5	2	5	2	5	2
Return Smoke Detector	5	2	5	2	5	2	5	2
Supply Smoke Detector	5	2	5	2	5	2	5	2
Fan/Filter Status Switch	2	1	2	1	2	1	2	1
Non-Fused Disconnect	15	7	15	7	15	7	15	7
Powered Convenience Outlet	35	16	35	16	35	16	35	16
Non-Powered Convenience Outlet	5	2	5	2	5	2	5	2
Enthalpy Sensor	2	1	2	1	2	1	2	1
Differential Enthalpy Sensor	3	1	3	1	3	1	3	1
Two Position Motorized Damper	50	23	50	23	50	23	65	29
Manual Damper	35	16	35	16	35	16	40	18
Field Filter Track 4-in (102mm)	12	5	12	5	12	5	12	5
MotorMaster Controller	39	18	39	18	39	18	39	18
Standard Static Motor/Drive	0	0	0	0	0	0	0	0
Medium Static Motor/Drive	5	2	6	3	6	3	6	3
High Static Motor/Drive	11	5	12	5	16	7	16	7
Barometric Relief Hood (Horizontal)	25	11	25	11	25	11	25	11
2-Speed Indoor Fan Motor System with VFD	20	9	20	9	20	9	20	9

\* For Perfect Humidity add MotorMaster Controller

### APPLICATION/SELECTION DATA

#### Min operating ambient temp (cooling):

In mechanical cooling mode, your Bryant rooftop can safely operate down to an outdoor ambient temperature of 35°F (2°C). It is possible to provide cooling at lower outdoor ambient temperatures by using less outside air, economizers, and/or accessory low ambient kits.

#### Max operating ambient temp (cooling):

The maximum operating ambient temperature for cooling mode is 115°F (46°C). While cooling operation above 115°F (46°C) may be possible, it could cause either a reduction in performance, reliability, or a protective action by the unit's internal safety devices.

#### Min and max airflow (cooling mode):

To maintain safe and reliable operation of your rooftop, operate within the cooling airflow limits. Operating above the max may cause blow-off, undesired airflow noise, or airflow related problems with the rooftop unit. Operating below the min may cause problems with coil freeze-up.

#### Airflow:

All units are draw-through in cooling mode.

#### Outdoor air application strategies:

Economizers reduce operating expenses and compressor run time by providing a free source of cooling and a means of ventilation to match application changing needs. In fact, they should be considered for most applications. Also, consider the various economizer control methods and their benefits, as well as sensors required to accomplish your application goals. Please contact your local Bryant representative for assistance.

#### Motor limits, break horsepower (BHP):

Due to Bryant's internal unit design, air path, and specially designed motors, the full horsepower (maximum continuous BHP) band, as listed in Table 5, can be used with the utmost confidence. There is no need for extra safety factors, as Bryant's motors are designed and rigorously tested to use the entire, listed BHP range without either nuisance tripping or premature motor failure.

## APPLICATION/SELECTION DATA (cont.)

### Sizing a rooftop

Bigger isn't necessarily better. While an air conditioner needs to have enough capacity to meet the load, it doesn't need excess capacity. In fact, having excess capacity typically results in very poor part load performance and humidity control.

Using higher design temperatures than ASHRAE recommends for your location, adding "safety factors" to the calculated load, and rounding up to the next largest unit, are all signs of oversizing air conditioners. Oversizing can cause short-cycling, and short cycling leads to poor humidity control, reduced efficiency, higher utility bills, drastic indoor temperature swings, excessive noise, and increased wear and tear on the air conditioner.

Rather than oversizing an air conditioner, wise contractors and engineers "right-size" or even slightly undersize air conditioners. Correctly sizing an air conditioner controls humidity better; promotes efficiency; reduces utility bills; extends equipment life, and maintains even, comfortable temperatures.

### Low ambient applications

When equipped with a Bryant economizer, your rooftop unit can cool your space by bringing in fresh, cool outside air. In fact, when so equipped, accessory low-ambient kit may not be necessary. In low ambient conditions, unless the outdoor air is excessively humid or contaminated, economizer-based "free cooling" is the preferred less costly and energy conscious method.

In low ambient applications where outside air might not be desired (such as contaminated or excessively humid outdoor environments), your Bryant rooftop can operate to ambient temperatures down to -20°F (-29°C) using the recommended accessory Motormaster low ambient controller.

### Winter start

Bryant's winter start kit extends the low ambient limit of your rooftop to 25°F (-4°C). The kit bypasses the low pressure switch, preventing nuisance tripping of the low pressure switch. Other low ambient precautions may still be prudent.

### Application/Selection Option

Selection software by Bryant saves time by performing many of the steps above. Contact your Bryant sales representative for assistance.

### 2-Speed Indoor Fan Motor with Variable Frequency Drive (VFD)

Bryant's 2-Speed Indoor Fan Motor System utilizes a Variable Frequency Drive (VFD) to automatically adjust the indoor fan motor speed in sequence with the units cooling operation. Per ASHRAE 90.1 2010 standard section 6.4.3.10.b, during the first stage of cooling operation the VFD will adjust the fan motor to provide 2/3rd of the total cfm established for the unit. When a call for the second stage of cooling is required, the VFD will allow the total cfm for the unit established (100%). During the heating mode, the VFD will allow total design cfm (100%) operation and during the ventilation mode the VFD will allow operation to 2/3rd of total cfm.

The VFD used in Bryant's 2-Speed Indoor Fan Motor System has soft start capabilities to slowly ramp up the speeds, thus eliminating any high inrush air volume during initial start-up. It also has internal over current protection for the fan motor and a field installed display kit that allows adjustment and in depth diagnostics of the VFD.

This 2-Speed Indoor Fan Motor System is available on models with 2-stage cooling operation with electrical mechanical or RTU Open (multi Protocol) controls. Both space sensor and conventional thermostats controls can be used to provide accurate control in any application.

The 2-Speed Indoor Fan Motor System is very flexible for initial fan performance set up and adjustment. The standard factory shipped VFD is pre programmed to automatically stage the fan speed between the first and second stage of cooling. The unit fan performance static pressure and cfm can be easily adjusted using the traditional means of pulley adjustments. The other means to adjust the unit static and cfm performance is to utilize the field installed display module and adjust the frequency and voltage in the VFD to required performance requirements. In either case, once set up the VFD will automatically adjust the speed between the cooling stage operation.

Table 7 – COOLING CAPACITIES

2-STAGE COOLING

15 TONS

558J*18D			AMBIENT TEMPERATURE													
			85			95			105			115				
			EAT (db)			EAT (db)			EAT (db)			EAT (db)				
			75	80	85	75	80	85	75	80	85	75	80	85		
4500 CFM	EAT (wb)	58	THC	158.3	158.3	179.2	152.6	152.6	172.9	146.6	146.6	166.1	140.2	140.2	158.8	
			SHC	137.3	158.3	179.2	132.4	152.6	172.9	127.2	146.6	166.1	121.6	140.2	158.8	
		62	THC	166.8	166.8	169.0	159.5	159.5	165.6	151.8	151.8	161.9	143.6	143.6	157.9	
			SHC	123.1	146.1	169.0	119.7	142.6	165.6	116.1	139.0	161.9	112.3	135.1	157.9	
		67	THC	182.9	182.9	182.9	174.9	174.9	174.9	166.3	166.3	166.3	157.2	157.2	157.2	
			SHC	100.0	123.1	146.1	96.7	119.8	142.8	93.2	116.3	139.4	89.7	112.7	135.7	
	72	THC	200.5	200.5	200.5	191.6	191.6	191.6	182.2	182.2	182.2	172.2	172.2	172.2		
		SHC	76.1	99.5	122.8	72.9	96.2	119.5	69.5	92.8	116.1	66.0	89.3	112.5		
	76	THC	-	215.4	215.4	-	205.8	205.8	-	195.6	195.6	-	184.8	184.8		
		SHC	-	80.2	105.0	-	77.1	101.7	-	73.7	98.2	-	70.2	94.5		
	5250 CFM	EAT (wb)	58	THC	166.7	166.7	188.8	160.6	160.6	181.9	154.0	154.0	174.4	147.0	147.0	166.5
				SHC	144.6	166.7	188.8	139.3	160.6	181.9	133.6	154.0	174.4	127.6	147.0	166.5
62			THC	172.0	172.0	185.1	164.3	164.3	181.2	156.3	156.3	177.0	147.8	147.8	172.4	
			SHC	132.5	158.8	185.1	128.9	155.1	181.2	125.0	151.0	177.0	120.9	146.6	172.4	
67			THC	188.3	188.3	188.3	179.7	179.7	179.7	170.7	170.7	170.7	161.0	161.0	161.0	
			SHC	106.1	132.7	159.3	102.8	129.3	155.9	99.3	125.8	152.4	95.6	122.1	148.6	
72		THC	206.1	206.1	206.1	196.7	196.7	196.7	186.7	186.7	186.7	176.2	176.2	176.2		
		SHC	78.8	105.6	132.5	75.5	102.3	129.1	72.1	98.8	125.6	68.5	95.2	121.9		
76		THC	-	221.2	221.2	-	211.0	211.0	-	200.3	200.3	-	189.0	189.0		
		SHC	-	83.6	111.7	-	80.3	108.2	-	76.9	104.6	-	73.3	100.9		
6000 CFM		EAT (wb)	58	THC	173.8	173.8	196.8	167.2	167.2	189.4	160.2	160.2	181.4	152.7	152.7	173.0
				SHC	150.8	173.8	196.8	145.1	167.2	189.4	139.0	160.2	181.4	132.5	152.7	173.0
	62		THC	176.3	176.3	199.5	168.5	168.5	194.9	160.5	160.5	188.9	152.9	152.9	179.9	
			SHC	140.9	170.2	199.5	136.9	165.9	194.9	132.1	160.5	188.9	125.8	152.9	179.9	
	67		THC	192.3	192.3	192.3	183.4	183.4	183.4	173.9	173.9	173.9	164.0	164.0	164.0	
			SHC	112.0	142.0	172.0	108.5	138.5	168.5	104.9	134.9	164.8	101.2	131.1	161.0	
	72	THC	210.4	210.4	210.4	200.6	200.6	200.6	190.2	190.2	190.2	179.3	179.3	179.3		
		SHC	81.2	111.4	141.7	77.9	108.0	138.2	74.4	104.5	134.6	70.7	100.8	130.8		
	76	THC	-	225.6	225.6	-	215.0	215.0	-	203.8	203.8	-	192.1	192.1		
		SHC	-	86.7	117.9	-	83.3	114.5	-	79.9	110.8	-	76.3	107.1		
	6750 CFM	EAT (wb)	58	THC	179.8	179.8	203.7	172.9	172.9	195.8	165.5	165.5	187.4	157.5	157.5	178.4
				SHC	156.0	179.8	203.7	150.0	172.9	195.8	143.5	165.5	187.4	136.7	157.5	178.4
62			THC	180.5	180.5	210.7	173.0	173.0	203.6	165.6	165.6	194.9	157.7	157.7	185.5	
			SHC	147.6	179.2	210.7	142.4	173.0	203.6	136.3	165.6	194.9	129.8	157.7	185.5	
67			THC	195.6	195.6	195.6	186.2	186.2	186.2	176.5	176.5	176.8	166.2	166.2	172.7	
			SHC	117.5	150.8	184.1	114.0	147.3	180.5	110.4	143.6	176.8	106.5	139.6	172.7	
72		THC	213.8	213.8	213.8	203.6	203.6	203.6	192.9	192.9	192.9	181.6	181.6	181.6		
		SHC	83.5	117.0	150.5	80.1	113.5	147.0	76.5	109.9	143.3	72.8	106.1	139.4		
76		THC	-	229.1	229.1	-	218.1	218.1	-	206.6	206.6	-	194.6	194.6		
		SHC	-	89.6	124.0	-	86.2	120.5	-	82.7	116.8	-	79.0	113.0		
7500 CFM		EAT (wb)	58	THC	185.1	185.1	209.6	177.7	177.7	201.3	170.0	170.0	192.5	161.6	161.6	183.0
				SHC	160.6	185.1	209.6	154.2	177.7	201.3	147.5	170.0	192.5	140.2	161.6	183.0
	62		THC	185.2	185.2	218.0	177.9	177.9	209.3	170.1	170.1	200.2	161.8	161.8	190.4	
			SHC	152.5	185.2	218.0	146.4	177.9	209.3	140.0	170.1	200.2	133.2	161.8	190.4	
	67		THC	198.1	198.1	198.1	188.6	188.6	192.1	178.6	178.6	188.1	168.1	168.1	183.8	
			SHC	122.8	159.3	195.9	119.2	155.7	192.1	115.5	151.8	188.1	111.5	147.7	183.8	
	72	THC	216.6	216.6	216.6	206.1	206.1	206.1	195.1	195.1	195.1	183.5	183.5	183.5		
		SHC	85.6	122.3	159.0	82.2	118.8	155.5	78.6	115.2	151.7	74.9	111.3	147.8		
	76	THC	-	231.9	231.9	-	220.7	220.7	-	208.9	208.9	-	196.5	196.5		
		SHC	-	92.4	129.9	-	88.9	126.3	-	85.4	122.6	-	81.6	118.7		

Note: See Minimum–Maximum Airflow Ratings in Table 3. Do not operate outside these limits.

LEGEND:

- Do not operate
- Cfm - Cubic feet per minute (supply air)
- EAT(db) - Entering air temperature (dry bulb)
- EAT(wb) - Entering air temperature (wet bulb)
- SHC - Sensible heat capacity
- TC - Total capacity

558J*18K (15 TONS) – UNIT WITH PERFECT HUMIDITY IN SUBCOOLING MODE										
Temp (F) Air Entering Condenser (Edb)		AIR ENTERING EVAPORATOR – CFM								
		4,500			6,000			7,500		
		Air Entering Evaporator -- Ewb (F)								
75	TC	202.9	184.6	166.2	213.7	194.6	175.4	222.3	202.5	182.7
	SHC	91.9	112.4	132.9	106.1	126.4	146.8	117.5	137.7	158.0
	kW	10.19	10.12	9.78	10.51	10.19	9.95	10.61	10.36	10.12
85	TC	189.8	171.8	153.8	201.0	182.2	163.3	209.9	190.4	170.8
	SHC	75.9	101.0	126.2	91.2	116.3	141.3	103.4	128.4	153.5
	kW	11.57	11.49	11.15	11.88	11.56	11.32	11.98	11.73	11.49
95	TC	176.7	159.1	141.4	188.3	169.7	151.2	197.5	178.2	159.0
	SHC	59.8	89.7	119.6	76.2	106.1	135.9	89.4	119.2	149.0
	kW	12.87	12.81	12.47	13.20	12.88	12.64	13.30	13.05	12.81
105	TC	163.6	146.3	129.0	175.6	157.3	139.1	185.1	166.1	147.1
	SHC	43.8	78.4	112.9	61.3	95.9	130.4	75.3	109.9	144.4
	kW	14.05	14.00	13.65	14.39	14.07	13.82	14.40	14.24	14.00
115	TC	150.5	133.5	116.5	162.9	144.9	127.0	172.7	154.0	135.3
	SHC	27.7	67.0	106.3	46.4	85.7	125.0	61.3	100.6	133.4
	kW	15.44	15.36	15.02	15.75	15.43	15.19	15.85	15.60	15.36

558J*18K (15 TONS) – UNIT WITH PERFECT HUMIDITY IN HOT GAS REHEAT MODE										
Temp (F) Air Entering Condenser (Edb)		AIR ENTERING EVAPORATOR – Ewb (F)								
		75 Dry Bulb			75 Dry Bulb			75 Dry Bulb		
		62.5 Wet Bulb			64 Wet Bulb			65.3 Wet Bulb		
		(50% Relative)			(56% Relative)			(60% Relative)		
		Air Entering Evaporator – Cfm								
		4,500	6,000	7,500	4,500	6,000	7,500	4,500	6,000	7,500
80	TC	64.50	71.00	73.30	68.40	74.50	77.30	71.20	79.70	80.60
	SHC	12.60	24.90	36.80	6.80	13.70	23.90	-0.80	5.50	13.80
	kW	10.10	10.26	10.42	10.18	10.40	10.56	10.33	10.47	10.67
75	TC	66.60	73.10	75.60	70.50	76.60	79.50	73.20	80.80	82.90
	SHC	14.30	26.70	38.50	8.10	14.90	25.70	0.70	7.00	15.00
	kW	10.05	10.22	10.36	10.14	10.36	10.52	10.28	10.43	10.62
70	TC	68.70	75.10	77.40	72.50	78.60	81.40	75.20	82.80	84.90
	SHC	15.40	27.80	40.00	9.50	16.20	26.80	2.10	8.40	16.30
	kW	10.00	10.18	10.33	10.10	10.31	10.47	10.23	10.40	10.58
60	TC	72.80	79.30	81.60	76.70	82.80	85.70	79.40	86.90	88.80
	SHC	19.00	31.10	43.20	12.70	19.90	30.10	5.30	11.60	20.00
	kW	9.92	10.09	10.24	10.01	10.22	10.37	10.14	10.31	10.49
50	TC	76.80	83.40	85.70	80.80	86.90	89.70	83.50	90.90	92.80
	SHC	21.70	34.20	46.20	15.80	22.70	33.20	8.40	14.70	22.80
	kW	9.83	10.00	10.15	9.92	10.13	10.29	10.05	10.21	10.39
40	TC	80.90	87.30	89.60	84.90	90.80	93.60	87.40	94.80	96.70
	SHC	24.90	37.10	49.30	19.00	26.00	36.10	11.60	17.90	26.20
	kW	9.74	9.91	10.06	9.83	10.04	10.20	9.96	10.12	10.30

**LEGEND**

- Edb** – Entering Dry–Bulb
- Ewb** – Entering Wet–Bulb
- kW** – Compressor Motor Power Input
- ldb** – Leaving Dry–Bulb
- lwb** – Leaving Wet–Bulb
- SHC** – Sensible Heat Capacity (1000 Btuh) Gross
- TC** – Total Capacity (1000 Btuh) Gross

**NOTES:**

1. Direct interpolation is permissible. Do not extrapolate.
2. The following formulas may be used:

$$t_{ldb} = t_{edb} - \frac{\text{sensible capacity (Btuh)}}{1.10 \times \text{cfm}}$$

$$t_{lwb} = \text{Wet–bulb temperature corresponding to enthalpy of air leaving evaporator coil } (h_{lwb})$$

$$h_{lwb} = h_{ewb} - \frac{\text{total capacity (Btuh)}}{4.5 \times \text{cfm}}$$

Where:  $h_{ewb}$  = Enthalpy of air entering evaporator coil

Table 9 – COOLING CAPACITIES

2-STAGE COOLING

17.5 TONS

558J*21D				AMBIENT TEMPERATURE												
				85			95			105			115			
				EAT (db)			EAT (db)			EAT (db)			EAT (db)			
CFM	EAT (wb)	Temp	Type	75	80	85	75	80	85	75	80	85	75	80	85	
				5250	62	58	THC	185.1	185.1	209.2	178.7	178.7	201.9	171.8	171.8	194.1
SHC	161.1	185.1	209.2				155.4	178.7	201.9	149.4	171.8	194.1	143.1	164.5	185.8	
62	THC	193.8	193.8			199.5	185.6	185.6	195.4	176.9	176.9	191.1	167.7	167.7	186.4	
	SHC	145.6	172.6			199.5	141.7	168.6	195.4	137.6	164.4	191.1	133.2	159.8	186.4	
67	THC	212.2	212.2			212.2	203.3	203.3	203.3	193.8	193.8	193.8	183.8	183.8	183.8	
	SHC	119.0	146.0			173.1	115.3	142.3	169.4	111.4	138.4	165.4	107.3	134.3	161.3	
72	THC	232.3	232.3		232.3	222.7	222.7	222.7	212.4	212.4	212.4	201.6	201.6	201.6		
	SHC	91.5	118.8		146.2	87.9	115.2	142.5	84.1	111.4	138.7	80.2	107.4	134.6		
76	THC	-	249.5		249.5	-	239.2	239.2	-	228.2	228.2	-	216.6	216.6		
	SHC	-	96.7		125.3	-	93.2	121.7	-	89.5	117.9	-	85.6	113.8		
6125	62	58	THC		194.7	194.7	220.0	187.8	187.8	212.2	180.4	180.4	203.8	172.5	172.5	194.9
			SHC		169.4	194.7	220.0	163.3	187.8	212.2	156.9	180.4	203.8	150.1	172.5	194.9
		62	THC	199.6	199.6	218.0	191.1	191.1	213.5	182.1	182.1	208.4	173.0	173.0	201.2	
			SHC	156.5	187.2	218.0	152.3	182.9	213.5	147.7	178.0	208.4	141.8	171.5	201.2	
		67	THC	218.0	218.0	218.0	208.7	208.7	208.7	198.7	198.7	198.7	188.2	188.2	188.2	
			SHC	126.2	157.4	188.6	122.4	153.6	184.7	118.4	149.6	180.7	114.3	145.4	176.5	
	72	THC	238.5	238.5	238.5	228.4	228.4	228.4	217.7	217.7	217.7	206.3	206.3	206.3		
		SHC	94.7	126.1	157.5	91.0	122.4	153.8	87.2	118.5	149.8	83.1	114.4	145.7		
	76	THC	-	255.9	255.9	-	245.1	245.1	-	233.6	233.6	-	221.4	221.4		
		SHC	-	100.7	133.3	-	97.1	129.6	-	93.3	125.6	-	89.3	121.5		
	7000	62	58	THC	202.7	202.7	229.1	195.4	195.4	220.8	187.5	187.5	211.9	179.2	179.2	202.5
				SHC	176.4	202.7	229.1	170.0	195.4	220.8	163.1	187.5	211.9	155.9	179.2	202.5
62			THC	204.6	204.6	234.4	196.0	196.0	228.0	187.7	187.7	220.3	179.3	179.3	210.5	
			SHC	166.0	200.2	234.4	160.8	194.4	228.0	155.1	187.7	220.3	148.2	179.3	210.5	
67			THC	222.5	222.5	222.5	212.8	212.8	212.8	202.4	202.4	202.4	191.5	191.5	191.5	
			SHC	133.0	168.2	203.4	129.2	164.3	199.5	125.1	160.3	195.4	120.9	156.0	191.0	
72		THC	243.3	243.3	243.3	232.7	232.7	232.7	221.6	221.6	221.6	209.9	209.9	209.9		
		SHC	97.5	132.9	168.3	93.8	129.2	164.5	89.9	125.2	160.5	85.8	121.1	156.3		
76		THC	-	260.8	260.8	-	249.6	249.6	-	237.7	237.7	-	225.1	225.1		
		SHC	-	104.4	140.8	-	100.7	137.0	-	96.9	133.0	-	92.8	128.8		
7875		62	58	THC	209.6	209.6	236.8	201.8	201.8	228.1	193.6	193.6	218.8	184.8	184.8	208.9
				SHC	182.3	209.6	236.8	175.6	201.8	228.1	168.4	193.6	218.8	160.8	184.8	208.9
	62		THC	209.8	209.8	246.2	202.0	202.0	237.1	193.8	193.8	227.4	185.0	185.0	217.1	
			SHC	173.4	209.8	246.2	167.0	202.0	237.1	160.1	193.8	227.4	152.9	185.0	217.1	
	67		THC	226.1	226.1	226.1	216.0	216.0	216.0	205.4	205.4	209.4	194.2	194.2	204.8	
			SHC	139.6	178.6	217.7	135.6	174.7	213.7	131.5	170.5	209.4	127.1	166.0	204.8	
	72	THC	247.0	247.0	247.0	236.2	236.2	236.2	224.7	224.7	224.7	212.7	212.7	212.7		
		SHC	100.2	139.5	178.8	96.5	135.7	174.9	92.5	131.7	170.9	88.4	127.5	166.6		
	76	THC	-	264.7	264.7	-	253.1	253.1	-	240.9	240.9	-	227.9	227.9		
		SHC	-	107.9	148.1	-	104.2	144.3	-	100.2	140.2	-	96.1	135.9		
	8750	62	58	THC	215.4	215.4	243.4	207.3	207.3	234.3	198.7	198.7	224.6	189.6	189.6	214.2
				SHC	187.4	215.4	243.4	180.3	207.3	234.3	172.9	198.7	224.6	164.9	189.6	214.2
62			THC	215.5	215.5	253.0	207.5	207.5	243.5	198.9	198.9	233.4	189.7	189.7	222.7	
			SHC	178.1	215.5	253.0	171.5	207.5	243.5	164.4	198.9	233.4	156.8	189.7	222.7	
67			THC	228.9	228.9	231.5	218.7	218.7	227.3	207.8	207.8	222.8	196.4	196.4	217.9	
			SHC	145.8	188.6	231.5	141.8	184.5	227.3	137.5	180.1	222.8	133.0	175.5	217.9	
72		THC	250.1	250.1	250.1	239.0	239.0	239.0	227.3	227.3	227.3	214.9	214.9	214.9		
		SHC	102.8	145.8	188.9	99.0	142.0	185.0	95.0	137.9	180.9	90.8	133.7	176.5		
76		THC	-	267.8	267.8	-	256.0	256.0	-	243.5	243.5	-	230.2	230.2		
		SHC	-	111.2	155.2	-	107.4	151.3	-	103.5	147.1	-	99.3	142.8		

Note: See Minimum–Maximum Airflow Ratings in Table 3. Do not operate outside these limits.

LEGEND:

- Do not operate
- Cfm - Cubic feet per minute (supply air)
- EAT(db) - Entering air temperature (dry bulb)
- EAT(wb) - Entering air temperature (wet bulb)
- SHC - Sensible heat capacity
- TC - Total capacity



Table 10 – COOLING CAPACITIES

2-STAGE COOLING

17.5 TONS (cont.)

558J*21K (17.5 TONS) – UNIT WITH PERFECT HUMIDITY IN SUBCOOLING MODE										
Temp (F) Air Entering Condenser (Edb)		AIR ENTERING EVAPORATOR – CFM								
		5,250			7,000			8,750		
		Air Entering Evaporator – Ewb (F)								
		72	67	62	72	67	62	72	67	62
75	TC	232.0	211.3	190.6	242.4	221.0	199.7	250.7	228.9	207.0
	SHC	110.9	133.7	156.4	127.6	150.3	173.0	141.1	163.7	186.4
	kW	12.45	12.16	11.81	12.74	12.41	12.02	12.93	12.51	12.18
85	TC	215.9	195.7	175.5	226.0	205.2	184.4	234.2	212.8	191.5
	SHC	90.6	118.8	147.0	108.4	136.6	164.9	122.7	151.0	179.2
	kW	13.48	13.20	12.88	13.77	13.47	13.07	13.96	13.58	13.23
95	TC	199.7	180.0	160.3	209.7	189.4	169.1	217.6	196.8	176.1
	SHC	70.3	104.0	137.7	89.2	123.0	156.7	104.4	138.2	172.1
	kW	14.60	14.25	13.94	14.89	14.51	14.15	15.08	14.63	14.31
105	TC	183.6	164.5	145.2	193.3	173.5	153.8	201.0	180.8	160.6
	SHC	50.0	89.1	128.3	70.0	109.3	148.6	86.0	125.5	158.6
	kW	15.64	15.36	15.01	15.93	15.60	15.21	16.12	15.72	15.37
115	TC	167.5	148.8	130.1	176.9	157.7	138.5	184.5	164.8	145.1
	SHC	29.7	74.3	118.9	50.7	95.6	138.1	67.7	112.7	145.1
	kW	16.70	16.38	15.82	16.98	16.63	16.03	17.17	16.75	16.19

558J*21K (17.5 TONS) – UNIT WITH PERFECT HUMIDITY IN HOT GAS REHEAT MODE										
Temp (F) Air Entering Condenser (Edb)		AIR ENTERING EVAPORATOR – Ewb (F)								
		75 Dry Bulb			75 Dry Bulb			75 Dry Bulb		
		62.5 Wet Bulb			64 Wet Bulb			65.3 Wet Bulb		
		(50% Relative)			(56% Relative)			(60% Relative)		
		Air Entering Evaporator – Cfm								
		5,250	7,000	8,750	5,250	7,000	8,750	5,250	7,000	8,750
80	TC	67.80	71.30	74.10	70.50	74.80	79.80	73.30	78.20	82.40
	SHC	9.00	26.50	41.70	2.20	13.20	26.90	-5.20	2.90	13.80
	kW	11.65	11.75	11.87	11.82	11.90	11.98	11.93	12.10	12.19
75	TC	72.50	76.00	78.80	75.00	79.20	84.30	78.00	83.00	86.90
	SHC	13.40	30.90	46.10	6.50	18.00	31.30	-2.10	7.20	17.90
	kW	11.44	11.54	11.66	11.61	11.68	11.75	11.70	11.86	11.95
70	TC	77.10	80.60	83.40	79.50	83.90	88.90	82.40	87.30	91.10
	SHC	17.60	34.70	49.90	10.80	22.20	35.10	3.20	11.50	22.20
	kW	11.22	11.33	11.45	11.40	11.46	11.54	11.49	11.64	11.75
60	TC	86.30	89.90	92.70	88.80	93.20	98.20	91.70	96.60	100.50
	SHC	26.20	43.20	58.40	19.40	30.80	43.60	11.60	20.10	30.70
	kW	10.76	10.86	10.98	10.93	11.00	11.07	11.03	11.18	11.28
50	TC	95.50	99.10	101.90	98.00	102.40	107.40	101.00	106.00	109.80
	SHC	34.80	51.80	67.00	28.00	39.40	52.20	20.10	28.70	39.40
	kW	10.33	10.43	10.55	10.50	10.52	10.63	10.59	10.74	10.85
40	TC	104.80	108.40	111.20	107.30	111.70	116.60	110.30	115.30	119.10
	SHC	43.40	60.40	75.60	36.60	48.00	60.80	28.80	37.30	47.90
	kW	9.87	9.97	10.09	10.04	10.11	10.18	10.14	10.28	10.40

LEGEND

- Edb – Entering Dry–Bulb
- Ewb – Entering Wet–Bulb
- kW – Compressor Motor Power Input
- ldb – Leaving Dry–Bulb
- lwb – Leaving Wet–Bulb
- SHC – Sensible Heat Capacity (1000 Btuh) Gross
- TC – Total Capacity (1000 Btuh) Gross

NOTES:

1. Direct interpolation is permissible. Do not extrapolate.
2. The following formulas may be used:

$$t_{ldb} = t_{edb} - \frac{\text{sensible capacity (Btuh)}}{1.10 \times \text{cfm}}$$

$t_{lwb}$  = Wet–bulb temperature corresponding to enthalpy of air leaving evaporator coil ( $h_{lwb}$ )

$$h_{lwb} = h_{ewb} - \frac{\text{total capacity (Btuh)}}{4.5 \times \text{cfm}}$$

Where:  $h_{ewb}$  = Enthalpy of air entering evaporator coil

Table 11 – COOLING CAPACITIES

2-STAGE COOLING

20 TONS

558J*25D			AMBIENT TEMPERATURE													
			85			95			105			115				
			EA (db)			EA (db)			EA (db)			EA (db)				
			75	80	85	75	80	85	75	80	85	75	80	85		
6000 CFM	EAT (wb)	58	THC	214.4	214.4	242.5	207.0	207.0	234.2	199.0	199.0	225.1	190.2	190.2	215.2	
		58	SHC	186.3	214.4	242.5	179.9	207.0	234.2	173.0	199.0	225.1	165.3	190.2	215.2	
		62	THC	226.8	226.8	227.7	217.3	217.3	223.0	206.9	206.9	218.0	195.8	195.8	212.5	
			SHC	167.0	197.3	227.7	162.4	192.7	223.0	157.6	187.8	218.0	152.3	182.4	212.5	
		67	THC	248.4	248.4	248.4	237.9	237.9	237.9	226.6	226.6	226.6	214.3	214.3	214.3	
			SHC	136.5	167.1	197.6	132.2	162.7	193.2	127.5	158.0	188.4	122.5	152.9	183.4	
	72	THC	271.9	271.9	271.9	260.3	260.3	260.3	247.9	247.9	247.9	234.5	234.5	234.5		
		SHC	105.1	136.0	167.0	100.8	131.7	162.5	96.3	127.1	157.9	91.4	122.1	152.9		
	76	THC	-	291.7	291.7	-	279.2	279.2	-	265.7	265.7	-	251.3	251.3		
		SHC	-	110.7	143.7	-	106.5	139.5	-	102.0	134.7	-	97.2	129.7		
	7000 CFM	EAT (wb)	58	THC	225.8	225.8	255.3	217.8	217.8	246.3	209.1	209.1	236.5	199.6	199.6	225.7
			58	SHC	196.2	225.8	255.3	189.3	217.8	246.3	181.7	209.1	236.5	173.4	199.6	225.7
62			THC	233.9	233.9	248.8	223.8	223.8	243.8	213.1	213.1	238.2	201.4	201.4	231.8	
			SHC	179.4	214.1	248.8	174.6	209.2	243.8	169.4	203.8	238.2	163.7	197.8	231.8	
67			THC	255.7	255.7	255.7	244.6	244.6	244.6	232.6	232.6	232.6	219.6	219.6	219.6	
			SHC	144.7	179.7	214.8	140.2	175.2	210.2	135.4	170.4	205.4	130.3	165.2	200.2	
72		THC	279.4	279.4	279.4	267.3	267.3	267.3	254.1	254.1	254.1	240.1	240.1	240.1		
		SHC	108.7	144.1	179.6	104.3	139.7	175.1	99.6	135.0	170.3	94.7	129.9	165.1		
76		THC	-	299.4	299.4	-	286.2	286.2	-	272.1	272.1	-	256.9	256.9		
		SHC	-	115.3	152.9	-	110.9	148.2	-	106.3	143.3	-	101.3	138.0		
8000 CFM		EAT (wb)	58	THC	235.3	235.3	266.2	226.8	226.8	256.5	217.5	217.5	246.0	207.4	207.4	234.5
			58	SHC	204.5	235.3	266.2	197.1	226.8	256.5	189.0	217.5	246.0	180.2	207.4	234.5
	62		THC	239.7	239.7	268.1	229.4	229.4	262.0	219.0	219.0	253.3	208.3	208.3	241.9	
			SHC	190.7	229.4	268.1	185.4	223.7	262.0	178.6	215.9	253.3	170.4	206.2	241.9	
	67		THC	261.3	261.3	261.3	249.6	249.6	249.6	237.1	237.1	237.1	223.6	223.6	223.6	
			SHC	152.3	191.8	231.2	147.7	187.1	226.6	142.9	182.2	221.6	137.7	177.0	216.3	
	72	THC	285.3	285.3	285.3	272.5	272.5	272.5	258.9	258.9	258.9	244.2	244.2	244.2		
		SHC	111.9	151.7	191.5	107.5	147.2	186.9	102.7	142.4	182.0	97.7	137.2	176.7		
	76	THC	-	305.4	305.4	-	291.6	291.6	-	276.8	276.8	-	261.2	261.2		
		SHC	-	119.4	161.0	-	114.9	156.2	-	110.1	151.2	-	105.1	146.0		
	9000 CFM	EAT (wb)	58	THC	243.5	243.5	275.4	234.5	234.5	265.2	224.6	224.6	254.0	213.9	213.9	241.9
			58	SHC	211.6	243.5	275.4	203.8	234.5	265.2	195.2	224.6	254.0	185.9	213.9	241.9
62			THC	245.4	245.4	282.9	235.4	235.4	274.6	225.0	225.0	264.3	214.4	214.4	251.7	
			SHC	199.7	241.3	282.9	193.2	233.9	274.6	185.6	224.9	264.3	176.8	214.3	251.7	
67			THC	265.6	265.6	265.6	253.6	253.6	253.6	240.7	240.7	240.7	226.8	226.8	231.8	
			SHC	159.6	203.3	247.1	154.9	198.6	242.3	150.0	193.6	237.3	144.7	188.3	231.8	
72		THC	289.9	289.9	289.9	276.7	276.7	276.7	262.6	262.6	262.6	247.5	247.5	247.5		
		SHC	114.9	159.0	203.0	110.4	154.4	198.3	105.6	149.5	193.3	100.5	144.2	188.0		
76		THC	-	310.1	310.1	-	295.8	295.8	-	280.6	280.6	-	264.4	264.4		
		SHC	-	123.2	168.9	-	118.6	164.1	-	113.8	159.0	-	108.7	153.6		
10,000 CFM		EAT (wb)	58	THC	250.4	250.4	283.2	240.9	240.9	272.5	230.7	230.7	260.9	219.5	219.5	248.2
			58	SHC	217.7	250.4	283.2	209.4	240.9	272.5	200.5	230.7	260.9	190.7	219.5	248.2
	62		THC	250.8	250.8	294.6	241.1	241.1	283.3	231.1	231.1	271.4	219.6	219.6	258.0	
			SHC	207.0	250.8	294.6	199.0	241.1	283.3	190.7	231.1	271.4	181.2	219.6	258.0	
	67		THC	269.2	269.2	269.2	256.8	256.8	257.6	243.5	243.5	252.3	229.4	229.4	246.4	
			SHC	166.6	214.5	262.5	161.9	209.7	257.6	156.8	204.5	252.3	151.3	198.9	246.4	
	72	THC	293.7	293.7	293.7	280.1	280.1	280.1	265.6	265.6	265.6	250.2	250.2	250.2		
		SHC	117.8	166.0	214.2	113.2	161.3	209.3	108.3	156.3	204.3	103.2	151.0	198.8		
	76	THC	-	313.9	313.9	-	299.3	299.3	-	283.7	283.7	-	267.1	267.1		
		SHC	-	126.8	176.5	-	122.2	171.6	-	117.3	166.5	-	112.1	161.0		

Note: See Minimum–Maximum Airflow Ratings in Table 3. Do not operate outside these limits.

LEGEND:

- Do not operate
- Cfm - Cubic feet per minute (supply air)
- EAT(db) - Entering air temperature (dry bulb)
- EAT(wb) - Entering air temperature (wet bulb)
- SHC - Sensible heat capacity
- TC - Total capacity

Table 12 – COOLING CAPACITIES

2-STAGE COOLING

20 TONS (cont.)

558J*25K (20 TONS) – UNIT WITH PERFECT HUMIDITY IN SUBCOOLING MODE										
Temp (F) Air Entering Condenser (Edb)		AIR ENTERING EVAPORATOR – CFM								
		6,000			8,000			10,000		
		Air Entering Evaporator – Ewb (F)								
		72	67	62	72	67	62	72	67	62
75	TC	281.6	256.5	231.3	293.1	267.0	240.9	302.3	275.4	248.6
	SHC	114.7	141.0	167.4	140.6	166.6	192.6	161.6	187.3	212.9
	kW	13.52	13.25	12.95	13.82	13.46	13.21	13.97	13.60	13.31
85	TC	261.3	236.9	212.4	272.1	247.7	221.3	280.7	254.6	228.5
	SHC	90.9	123.5	156.1	118.8	151.1	183.3	141.4	173.4	205.4
	kW	14.95	14.68	14.48	15.25	14.89	14.64	15.40	15.03	14.74
95	TC	241.1	217.2	193.4	251.1	226.4	201.7	259.2	233.8	208.4
	SHC	67.2	106.0	144.8	97.1	120.1	174.1	121.2	159.5	197.8
	kW	16.52	16.25	15.95	16.82	16.46	16.21	16.97	16.60	16.31
105	TC	220.8	197.5	174.4	230.2	206.2	182.2	237.7	213.0	188.4
	SHC	43.4	88.4	133.5	75.3	120.1	164.9	101.0	145.7	178.9
	kW	18.09	17.82	17.52	18.39	18.03	17.78	18.54	18.17	17.88
115	TC	200.5	178.0	155.5	209.2	185.9	162.6	216.2	192.2	168.7
	SHC	19.7	70.9	122.2	53.5	104.6	155.7	80.9	131.8	161.2
	kW	19.65	19.38	19.08	19.95	19.59	19.34	20.10	19.73	19.44

558J*25K (20 TONS) – UNIT WITH PERFECT HUMIDITY IN HOT GAS REHEAT MODE										
Temp (F) Air Entering Condenser (Edb)		AIR ENTERING EVAPORATOR – Ewb (F)								
		75 Dry Bulb			75 Dry Bulb			75 Dry Bulb		
		62.5 Wet Bulb			64 Wet Bulb			65.3 Wet Bulb		
		(50% Relative)			(56% Relative)			(60% Relative)		
		Air Entering Evaporator – Cfm								
6,000	8,000	10,000	6,000	8,000	10,000	6,000	8,000	10,000		
80	TC	115.20	123.30	130.60	120.40	129.30	138.20	122.80	135.00	143.70
	SHC	40.80	58.30	76.10	32.30	45.50	60.40	20.10	34.30	48.00
	kW	13.24	13.32	13.39	13.43	13.57	13.65	13.49	13.68	13.74
75	TC	119.80	128.60	135.90	125.50	135.30	143.20	128.00	139.50	148.40
	SHC	45.60	62.80	82.10	37.00	49.80	65.20	24.30	38.70	52.60
	kW	13.05	13.10	13.17	13.21	13.35	13.43	13.27	13.46	13.52
70	TC	122.50	133.10	140.20	129.80	140.70	147.60	132.40	144.40	153.20
	SHC	49.80	76.00	86.10	41.10	54.30	69.20	28.80	41.40	56.80
	kW	12.80	12.87	12.94	12.98	13.12	13.20	13.04	13.23	13.29
60	TC	133.80	142.50	149.60	139.30	150.40	157.40	141.50	154.20	163.00
	SHC	58.60	76.00	95.00	50.20	63.50	78.10	37.80	52.10	65.90
	kW	12.34	12.42	12.49	12.53	12.67	12.75	12.59	12.78	12.84
50	TC	143.50	151.80	159.30	149.00	160.00	167.00	151.30	163.60	172.50
	SHC	67.70	84.80	103.80	59.10	72.40	87.00	46.70	61.00	74.90
	kW	11.88	11.95	12.03	12.07	12.21	12.29	12.13	12.32	12.38
40	TC	153.20	161.30	168.70	158.60	169.20	176.60	160.80	173.10	182.00
	SHC	76.50	93.60	111.60	68.00	81.50	95.80	55.80	69.80	84.00
	kW	11.42	11.49	11.56	11.60	11.74	11.82	11.66	11.85	11.91

LEGEND

- Edb – Entering Dry–Bulb
- Ewb – Entering Wet–Bulb
- kW – Compressor Motor Power Input
- ldb – Leaving Dry–Bulb
- lwb – Leaving Wet–Bulb
- SHC – Sensible Heat Capacity (1000 Btuh) Gross
- TC – Total Capacity (1000 Btuh) Gross

NOTES:

1. Direct interpolation is permissible. Do not extrapolate.
2. The following formulas may be used:

$$t_{ldb} = t_{edb} - \frac{\text{sensible capacity (Btuh)}}{1.10 \times \text{cfm}}$$

t<sub>lwb</sub> = Wet–bulb temperature corresponding to enthalpy of air leaving evaporator coil (h<sub>lwb</sub>)

$$h_{lwb} = h_{ewb} - \frac{\text{total capacity (Btuh)}}{4.5 \times \text{cfm}}$$

Where: h<sub>ewb</sub> = Enthalpy of air entering evaporator coil

Table 13 – COOLING CAPACITIES

2-STAGE COOLING

25 TONS

558J*29D			AMBIENT TEMPERATURE													
			85			95			105			115				
			EA (db)			EA (db)			EA (db)			EA (db)				
			75	80	85	75	80	85	75	80	85	75	80	85		
7,500 CFM	EAT (wb)	58	THC	264.4	264.4	298.9	254.6	254.6	287.9	244.1	244.1	276.0	232.7	232.7	263.1	
		58	SHC	229.9	264.4	298.9	221.4	254.6	287.9	212.2	244.1	276.0	202.3	232.7	263.1	
		62	THC	278.7	278.7	282.4	266.3	266.3	276.4	252.8	252.8	269.8	238.5	238.5	262.4	
		62	SHC	206.8	244.6	282.4	200.9	238.7	276.4	194.6	232.2	269.8	187.7	225.0	262.4	
		67	THC	305.3	305.3	305.3	291.9	291.9	291.9	277.3	277.3	277.3	261.5	261.5	261.5	
		67	SHC	169.0	207.0	245.0	163.4	201.4	239.4	157.4	195.3	233.3	151.0	188.9	226.8	
	72	THC	334.0	334.0	334.0	319.4	319.4	319.4	303.6	303.6	303.6	286.5	286.5	286.5		
	72	SHC	129.9	168.5	207.1	124.5	163.0	201.5	118.7	157.1	195.5	112.5	150.8	189.2		
	76	THC	-	358.2	358.2	-	342.4	342.4	-	325.4	325.4	-	307.1	307.1		
	76	SHC	-	137.0	178.2	-	131.7	172.9	-	126.0	166.9	-	119.9	160.4		
	8,750 CFM	EAT (wb)	58	THC	278.2	278.2	314.5	267.8	267.8	302.8	256.5	256.5	289.9	244.2	244.2	276.1
			58	SHC	241.9	278.2	314.5	232.8	267.8	302.8	223.0	256.5	289.9	212.3	244.2	276.1
62			THC	287.2	287.2	308.3	274.3	274.3	301.5	260.8	260.8	291.7	247.0	247.0	280.9	
62			SHC	222.1	265.2	308.3	215.7	258.6	301.5	207.7	249.7	291.7	199.0	240.0	280.9	
67			THC	314.0	314.0	314.0	299.8	299.8	299.8	284.4	284.4	284.4	267.8	267.8	267.8	
67			SHC	179.1	222.7	266.4	173.3	216.9	260.6	167.2	210.8	254.3	160.7	204.2	247.7	
72		THC	343.0	343.0	343.0	327.7	327.7	327.7	311.1	311.1	311.1	293.1	293.1	293.1		
72		SHC	134.3	178.5	222.6	128.8	172.9	216.9	122.9	166.9	210.8	116.6	160.4	204.3		
76		THC	-	367.3	367.3	-	350.8	350.8	-	333.0	333.0	-	313.8	313.8		
76		SHC	-	142.6	189.4	-	137.1	183.5	-	131.2	177.3	-	125.0	170.7		
10,000 CFM		EAT (wb)	58	THC	289.7	289.7	327.5	278.7	278.7	315.0	266.6	266.6	301.4	253.6	253.6	286.7
			58	SHC	251.9	289.7	327.5	242.3	278.7	315.0	231.8	266.6	301.4	220.5	253.6	286.7
	62		THC	294.6	294.6	329.6	282.2	282.2	319.7	268.7	268.7	309.1	254.1	254.1	298.4	
	62		SHC	234.7	282.1	329.6	226.8	273.3	319.7	218.4	263.7	309.1	209.7	254.1	298.4	
	67		THC	320.6	320.6	320.6	305.9	305.9	305.9	289.9	289.9	289.9	272.7	272.7	272.7	
	67		SHC	188.6	237.7	286.8	182.7	231.8	280.9	176.5	225.5	274.5	169.8	218.8	267.7	
	72	THC	350.0	350.0	350.0	334.0	334.0	334.0	316.8	316.8	316.8	298.2	298.2	298.2		
	72	SHC	138.4	187.9	237.5	132.8	182.2	231.7	126.8	176.1	225.5	120.4	169.6	218.8		
	76	THC	-	374.4	374.4	-	357.3	357.3	-	338.7	338.7	-	318.9	318.9		
	76	SHC	-	147.7	199.5	-	142.1	193.7	-	136.1	187.4	-	129.7	180.6		
	11,250 CFM	EAT (wb)	58	THC	299.4	299.4	338.4	287.8	287.8	325.4	275.2	275.2	311.1	261.4	261.4	295.6
			58	SHC	260.3	299.4	338.4	250.2	287.8	325.4	239.2	275.2	311.1	227.3	261.4	295.6
62			THC	302.2	302.2	346.0	289.3	289.3	335.7	275.5	275.5	323.5	262.1	262.1	307.7	
62			SHC	244.8	295.4	346.0	236.7	286.2	335.7	227.5	275.5	323.5	216.4	262.1	307.7	
67			THC	325.9	325.9	325.9	310.7	310.7	310.7	294.2	294.2	294.2	276.6	276.6	286.7	
67			SHC	197.6	252.1	306.5	191.7	246.1	300.4	185.3	239.6	293.9	178.5	232.6	286.7	
72		THC	355.5	355.5	355.5	339.1	339.1	339.1	321.3	321.3	321.3	302.2	302.2	302.2		
72		SHC	142.1	197.0	251.8	136.4	191.2	245.9	130.4	185.0	239.6	123.9	178.3	232.8		
76		THC	-	380.0	380.0	-	362.4	362.4	-	343.3	343.3	-	322.8	322.8		
76		SHC	-	152.4	209.4	-	146.8	203.4	-	140.7	197.0	-	134.2	190.2		
12,500 CFM		EAT (wb)	58	THC	307.7	307.7	347.9	295.7	295.7	334.2	282.5	282.5	319.3	268.2	268.2	303.2
			58	SHC	267.6	307.7	347.9	257.1	295.7	334.2	245.6	282.5	319.3	233.2	268.2	303.2
	62		THC	308.4	308.4	362.2	295.9	295.9	347.4	283.1	283.1	332.4	268.4	268.4	315.2	
	62		SHC	254.6	308.4	362.2	244.4	295.9	347.4	233.8	283.1	332.4	221.7	268.4	315.2	
	67		THC	330.2	330.2	330.2	314.6	314.6	319.2	297.8	297.8	312.3	279.8	279.8	304.7	
	67		SHC	206.3	265.9	325.5	200.3	259.7	319.2	193.8	253.1	312.3	186.7	245.7	304.7	
	72	THC	360.1	360.1	360.1	343.2	343.2	343.2	325.0	325.0	325.0	305.4	305.4	305.4		
	72	SHC	145.7	205.7	265.7	139.9	199.8	259.7	133.8	193.5	253.3	127.3	186.8	246.3		
	76	THC	-	384.6	384.6	-	366.5	366.5	-	346.9	346.9	-	325.9	325.9		
	76	SHC	-	157.0	218.9	-	151.2	212.9	-	145.1	206.3	-	138.5	199.3		

Note: See Minimum–Maximum Airflow Ratings in Table 3. Do not operate outside these limits.

LEGEND:

- Do not operate
- Cfm - Cubic feet per minute (supply air)
- EAT(db) - Entering air temperature (dry bulb)
- EAT(wb) - Entering air temperature (wet bulb)
- SHC - Sensible heat capacity
- TC - Total capacity

558J*29K (25 TONS) – UNIT WITH PERFECT HUMIDITY IN SUBCOOLING MODE										
Temp (F) Air Entering Condenser (Edb)		AIR ENTERING EVAPORATOR – CFM								
		7,500			10,000			12,500		
		Air Entering Evaporator – Ewb (F)								
		72	67	62	72	67	62	72	67	62
75	TC	351.3	319.5	287.8	370.4	337.3	304.1	385.8	351.5	317.2
	SHC	166.5	199.4	232.3	191.2	245.6	258.5	211.4	245.6	279.9
	kW	16.75	16.55	15.20	17.30	16.75	15.85	17.80	17.50	16.50
85	TC	327.5	296.4	265.3	346.1	313.6	281.2	361.1	327.5	294.0
	SHC	137.4	178.2	219.0	162.6	204.5	246.4	183.3	226.0	268.7
	kW	18.65	18.45	17.25	19.20	18.65	17.80	19.45	19.15	18.15
95	TC	303.7	273.3	242.9	321.8	290.0	258.3	336.4	303.5	270.7
	SHC	108.2	157.0	205.8	134.0	184.1	234.3	155.1	206.4	257.6
	kW	20.60	20.40	19.34	21.15	20.60	19.95	21.60	21.30	20.30
105	TC	279.9	250.2	220.4	297.5	266.4	235.3	311.7	279.5	247.4
	SHC	79.0	135.8	192.5	105.4	163.8	222.2	127.1	186.7	246.4
	kW	22.85	22.65	21.45	23.40	22.85	22.05	23.70	23.40	22.40
115	TC	256.2	227.1	198.0	273.2	242.8	212.4	287.0	255.5	224.1
	SHC	49.9	114.5	179.2	76.8	143.4	210.1	98.9	167.1	223.8
	kW	25.05	24.85	23.65	25.60	25.05	24.25	25.90	25.60	24.60

558J*29K (25 TONS) – UNIT WITH PERFECT HUMIDITY IN HOT GAS REHEAT MODE										
Temp (F) Air Entering Condenser (Edb)		AIR ENTERING EVAPORATOR – Ewb (F)								
		75 Dry Bulb			75 Dry Bulb			75 Dry Bulb		
		62.5 Wet Bulb			64 Wet Bulb			65.3 Wet Bulb		
		(50% Relative)			(56% Relative)			(60% Relative)		
		Air Entering Evaporator – Cfm								
7,500	10,000	12,500	7,500	10,000	12,500	7,500	10,000	12,500		
80	TC	124.40	133.90	139.00	132.00	142.10	145.10	135.60	149.10	151.50
	SHC	37.60	60.70	82.20	27.80	45.40	65.80	17.50	34.20	50.10
	kW	15.83	15.90	16.00	15.97	16.13	16.16	16.11	16.31	16.38
75	TC	129.00	138.50	144.60	136.60	147.60	150.10	140.60	154.00	156.30
	SHC	47.10	70.60	92.10	37.30	55.30	75.70	27.00	43.70	60.00
	kW	15.77	15.83	15.94	15.91	16.07	16.10	16.05	16.25	16.32
70	TC	133.60	143.10	149.20	141.20	152.30	154.80	145.30	158.80	161.10
	SHC	57.30	80.70	102.20	47.50	65.40	85.80	37.20	53.90	70.10
	kW	15.68	15.75	15.86	15.83	16.00	16.04	15.88	16.08	16.15
60	TC	142.80	158.40	158.40	150.40	161.40	163.90	153.90	167.40	169.70
	SHC	76.50	121.40	121.40	66.70	84.60	105.00	56.40	73.10	89.30
	kW	15.54	15.60	15.71	15.68	15.84	15.87	15.82	16.02	16.09
50	TC	151.80	161.30	167.40	159.40	170.50	173.20	162.80	176.20	178.80
	SHC	94.10	117.50	139.00	84.30	102.20	122.60	74.00	90.70	106.90
	kW	15.40	15.47	15.58	15.54	15.68	15.71	15.66	15.86	15.93
40	TC	161.20	170.70	176.80	168.80	179.80	182.50	172.20	185.70	188.20
	SHC	114.10	137.60	159.10	104.30	122.30	142.70	94.00	110.70	127.00
	kW	15.24	15.31	15.42	15.39	15.55	15.58	15.53	15.73	15.80

**LEGEND**

- Edb** – Entering Dry–Bulb
- Ewb** – Entering Wet–Bulb
- kW** – Compressor Motor Power Input
- ldb** – Leaving Dry–Bulb
- lwb** – Leaving Wet–Bulb
- SHC** – Sensible Heat Capacity (1000 Btuh) Gross
- TC** – Total Capacity (1000 Btuh) Gross

**NOTES:**

1. Direct interpolation is permissible. Do not extrapolate.
2. The following formulas may be used:

$$t_{ldb} = t_{edb} - \frac{\text{sensible capacity (Btuh)}}{1.10 \times \text{cfm}}$$

$t_{lwb}$  = Wet–bulb temperature corresponding to enthalpy of air leaving evaporator coil ( $h_{lwb}$ )

$$h_{lwb} = h_{ewb} - \frac{\text{total capacity (Btuh)}}{4.5 \times \text{cfm}}$$

Where:  $h_{ewb}$  = Enthalpy of air entering evaporator coil

**Table 15 – STATIC PRESSURE ADDERS (IN. WG) - FACTORY OPTIONS AND/OR ACCESSORIES**

**Perfect Humidity**

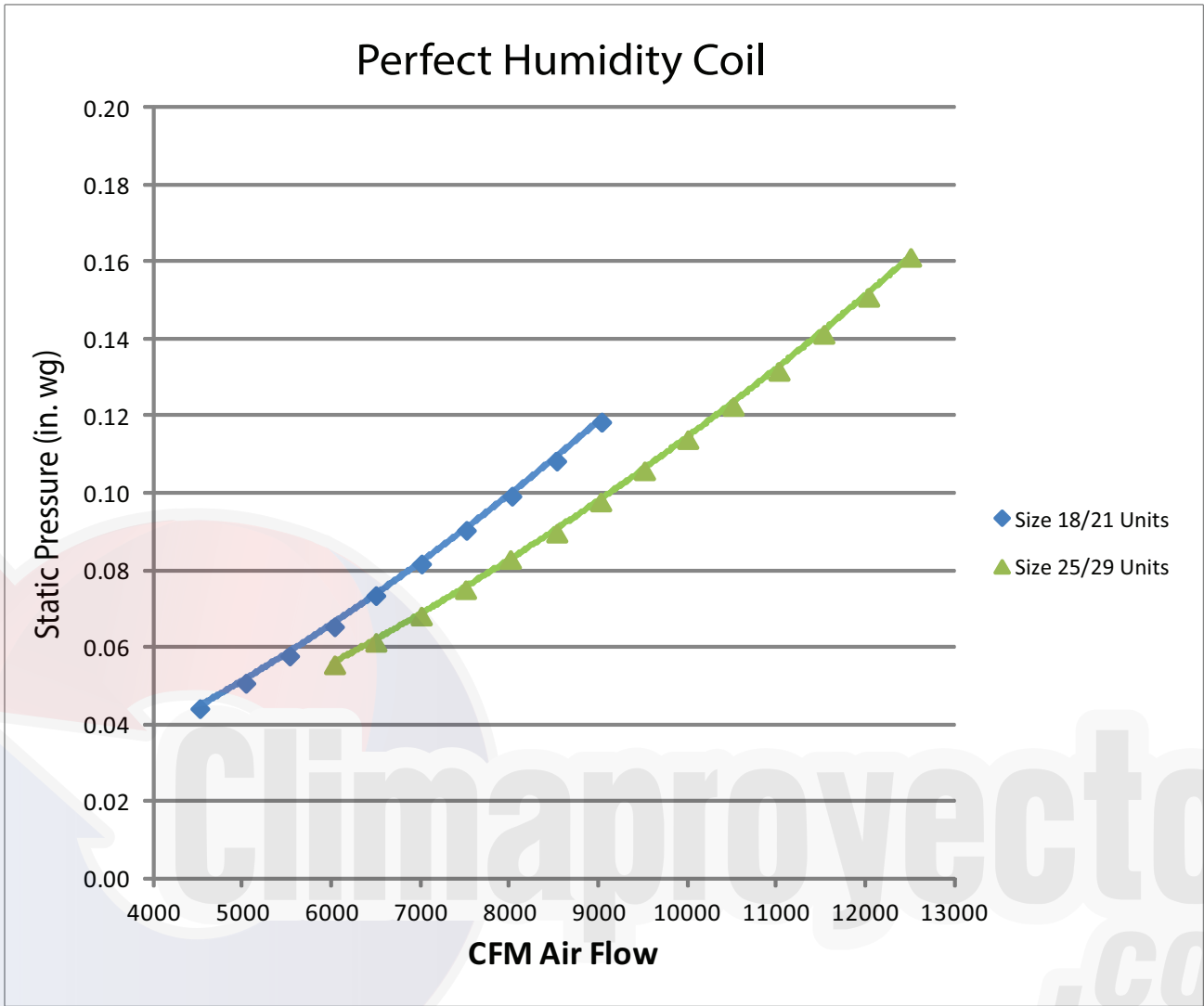

C13858

**Economizer - Horizontal Duct Configuration**

MODEL SIZES 18-29								
CFM	4500	5000	5500	6000	6500	7000	7500	8000
Static Pressure Adder (in. wg)	0.047	0.052	0.057	0.062	0.067	0.072	0.077	0.082

MODEL SIZES 18-29									
CFM	8500	9000	9500	10000	10500	11000	11500	12000	12500
Static Pressure Adder (in. wg)	0.088	0.093	0.098	0.103	0.109	0.114	0.119	0.125	0.131

**Electric Heaters - Horizontal Duct Configuration**

MODEL SIZES 18-29								
CFM	4800	5000	6000	7000	8000	9000	10000	11500
25 kW Heater	0.010	0.010	0.020	0.030	0.040	0.050	0.060	0.090
50 kW Heater	0.020	0.020	0.040	0.060	0.080	0.100	0.130	0.180
75 kW Heater	0.030	0.040	0.060	0.080	0.120	0.150	0.200	0.270



# DAMPER, BAROMETRIC RELIEF AND PE PERFORMANCE

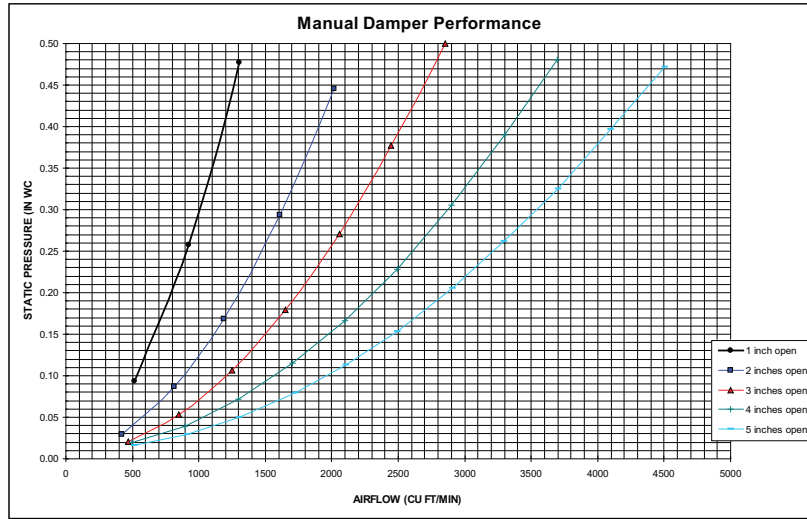

Fig. 9 - Manual Damper Performance

C09264

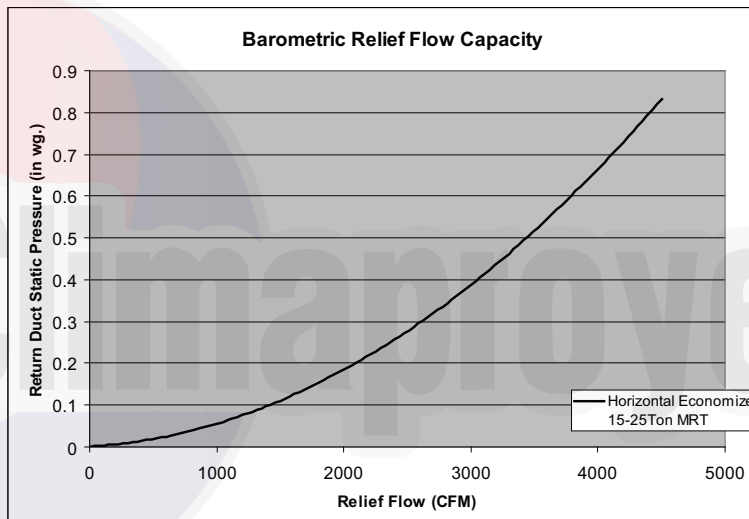

Fig. 10 - Barometric Relief Flow Capacity

C13850

## Power Exhaust Fan Performance

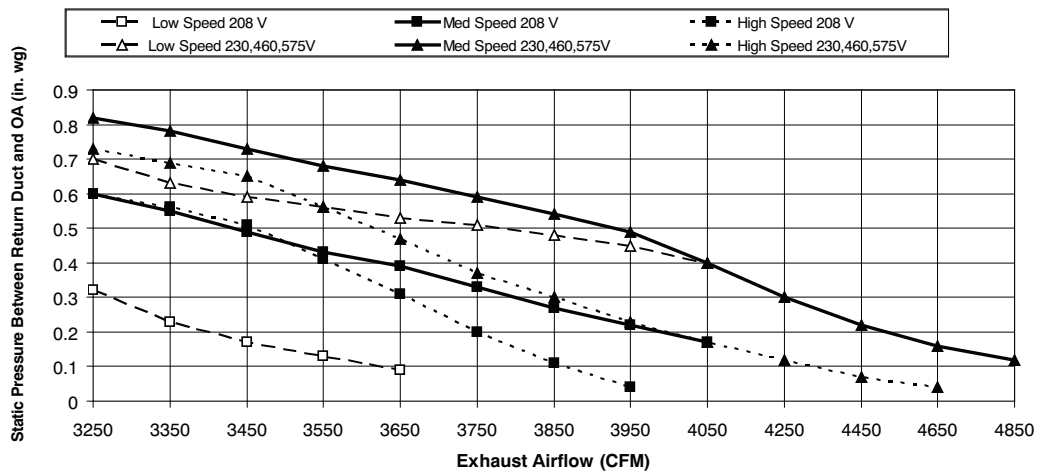

Fig. 11 - Power Exhaust Fan Performance

C11308

## GENERAL FAN PERFORMANCE NOTES:

1. Interpolation is permissible. Do not extrapolate.
2. External static pressure is the static pressure difference between the return duct and the supply duct plus the static pressure caused by any FIOPs or accessories.
3. Tabular data accounts for pressure loss due to clean filters, unit casing, and wet coils. Factory options and accessories may add static pressure losses. Selection software is available, through your salesperson, to help you select the best motor/drive combination for your application.
4. The Fan Performance tables offer motor/drive recommendations. In cases when two motor/drive combinations would work, Bryant recommended the lower horsepower option.
5. For information on the electrical properties of Bryant motors, please see the Electrical information section of this book.
6. For more information on the performance limits of Bryant motors, see the application data section of this book.



# FAN PERFORMANCE

Table 16 – 558J\*18

## HORIZONTAL SUPPLY / RETURN

15 TON

CFM	Available External Static Pressure (in. wg)									
	0.2		0.4		0.6		0.8		1.0	
	RPM	BHP	RPM	BHP	RPM	BHP	RPM	BHP	RPM	BHP
4500	451	0.84	533	1.21	605	1.63	668	2.12	726	2.67
4900	476	1.01	554	1.40	623	1.84	685	2.34	742	2.89
5250	498	1.18	573	1.60	640	2.05	701	2.55	756	3.11
5600	520	1.37	593	1.82	658	2.28	717	2.79	771	3.35
6000	546	1.61	616	2.10	679	2.58	736	3.10	789	3.67
6400	572	1.88	640	2.41	700	2.91	756	3.45	808	4.03
6750	595	2.13	661	2.70	720	3.23	774	3.79	825	4.38
7100	619	2.41	683	3.02	740	3.59	793	4.16	842	4.76
7500	646	2.75	708	3.42	764	4.02	815	4.62	863	5.23

CFM	Available External Static Pressure (in. wg)									
	1.2		1.4		1.6		1.8		2.0	
	RPM	BHP	RPM	BHP	RPM	BHP	RPM	BHP	RPM	BHP
4500	778	3.25	826	3.86	871	4.49	913	5.15	-	-
4900	794	3.49	842	4.12	887	4.78	-	-	-	-
5250	808	3.72	856	4.36	900	5.04	-	-	-	-
5600	822	3.97	870	4.62	-	-	-	-	-	-
6000	839	4.29	886	4.96	-	-	-	-	-	-
6400	857	4.65	-	-	-	-	-	-	-	-
6750	873	5.01	-	-	-	-	-	-	-	-
7100	-	-	-	-	-	-	-	-	-	-
7500	-	-	-	-	-	-	-	-	-	-

Standard Static Motor and Drive – 514 – 680 RPM, Max BHP 2.2	Medium Static Motor and Drive – 614 – 780 RPM, Max BHP 3.3
High Static Motor and Drive – 746 – 912 RPM, Max BHP 4.9	– Outside operating range
<b>Boldface</b> – Field Supplied Drive	<i>ITALIC</i> – Field Supplied Motor and Drive
<i><b>ITALIC Boldface</b></i> – Field Supplied Drive with Medium Static Motor	

Table 17 – 558J\*21

## HORIZONTAL SUPPLY / RETURN

17.5 TON

CFM	Available External Static Pressure (in. wg)									
	0.2		0.4		0.6		0.8		1.0	
	RPM	BHP	RPM	BHP	RPM	BHP	RPM	BHP	RPM	BHP
5250	498	1.18	573	1.60	640	2.05	701	2.55	756	3.11
5700	526	1.43	599	1.89	663	2.35	721	2.86	776	3.43
6100	552	1.67	622	2.17	684	2.66	741	3.18	794	3.76
6500	579	1.95	646	2.49	706	3.00	761	3.54	813	4.12
7000	612	2.33	677	2.93	734	3.48	788	4.05	837	4.64
7500	646	2.75	708	3.42	764	4.02	815	4.62	863	5.23
7900	673	3.13	734	3.86	788	4.50	<u>838</u>	<u>5.12</u>	884	5.75
8300	700	3.53	760	4.33	<u>812</u>	<u>5.01</u>	<u>861</u>	<u>5.66</u>	906	6.32
8750	731	4.03	789	4.90	<u>840</u>	<u>5.63</u>	887	6.33	932	7.02

CFM	Available External Static Pressure (in. wg)									
	1.2		1.4		1.6		1.8		2.0	
	RPM	BHP	RPM	BHP	RPM	BHP	RPM	BHP	RPM	BHP
5250	808	3.72	856	4.36	901	5.04	943	5.75	983	6.48
5700	826	4.05	874	4.71	918	5.40	960	6.13	1000	6.89
6100	843	4.38	890	5.05	934	5.75	976	6.50	1016	7.27
6500	861	4.75	907	5.43	951	6.14	992	6.90	1032	7.69
7000	885	5.28	929	5.96	972	6.69	1013	7.45	-	-
7500	909	5.88	953	6.58	994	7.31	-	-	-	-
7900	929	6.42	972	7.12	-	-	-	-	-	-
8300	950	7.01	992	7.72	-	-	-	-	-	-
8750	-	-	-	-	-	-	-	-	-	-

Standard Static Motor and Drive – 622 – 822 RPM, Max BHP 3.3	Medium Static Motor and Drive – 713 – 879 RPM, Max BHP 4.9
High Static Motor and Drive – 882 – 1078 RPM, Max BHP 6.5	– Outside operating range
<b>Boldface</b> – Field Supplied Drive	<i>ITALIC</i> – Field Supplied Motor and Drive
<i><b>ITALIC Boldface</b></i> – Field Supplied Drive with Medium Static Motor	<u>Underscore</u> – Field Supplied Drive with High Static Motor

## FAN PERFORMANCE (cont.)

Table 18 – 558J\*25

### HORIZONTAL SUPPLY / RETURN

20 TON

CFM	Available External Static Pressure (in. wg)									
	0.2		0.4		0.6		0.8		1.0	
	RPM	BHP	RPM	BHP	RPM	BHP	RPM	BHP	RPM	BHP
6000	546	1.57	617	2.10	680	2.67	738	3.29	790	3.93
6500	579	1.90	646	2.46	707	3.07	763	3.71	814	4.39
7000	613	2.28	677	2.87	735	3.51	789	4.19	839	4.89
7500	648	2.71	708	3.34	764	4.01	816	4.72	865	5.46
8000	683	3.20	740	3.86	794	4.57	846	5.30	892	6.08
8500	718	3.76	773	4.45	825	5.18	873	5.95	919	6.75
9000	754	4.37	814	5.10	856	5.87	<u>903</u>	<u>6.67</u>	947	7.50
9500	790	5.06	840	5.82	<u>887</u>	<u>6.51</u>	<u>933</u>	<u>7.45</u>	976	8.31
10000	826	5.82	874	6.50	<u>920</u>	<u>7.44</u>	965	8.30	-	-
CFM	Available External Static Pressure (in. wg)									
	1.2		1.4		1.6		1.8		2.0	
	RPM	BHP	RPM	BHP	RPM	BHP	RPM	BHP	RPM	BHP
6000	839	4.60	885	5.29	928	6.01	969	6.75	1008	7.51
6500	862	5.09	907	5.82	950	6.57	990	7.34	1028	8.13
7000	886	5.63	930	6.39	972	7.17	1012	7.97	1050	8.70
7500	911	6.22	954	7.01	995	7.83	1035	8.66	-	-
8000	<u>936</u>	<u>6.87</u>	979	7.69	1019	8.54	-	-	-	-
8500	965	7.58	1004	8.44	-	-	-	-	-	-
9000	990	8.36	-	-	-	-	-	-	-	-
9500	-	-	-	-	-	-	-	-	-	-
10000	-	-	-	-	-	-	-	-	-	-
Standard Static Motor and Drive – 690 – 680 RPM, Max BHP 4.9					Medium Static Motor and Drive – 835 – 1021 RPM, Max BHP 6.5					
High Static Motor and Drive – 941 – 1176 RPM, Max BHP 8.7					– Outside operating range					
<b>Boldface</b> – Field Supplied Drive					<u>Underscore</u> – Field Supplied Drive with High Static Motor					
<i>ITALIC Boldface</i> – Field Supplied Drive with Medium Static Motor										

Table 19 – 558J\*29

### HORIZONTAL SUPPLY / RETURN

25 TON

CFM	Available External Static Pressure (in. wg)									
	0.2		0.4		0.6		0.8		1.0	
	RPM	BHP	RPM	BHP	RPM	BHP	RPM	BHP	RPM	BHP
7500	553	1.92	621	2.46	683	3.07	741	3.72	795	4.42
8000	575	2.21	639	2.77	700	3.39	756	4.07	809	4.78
8500	596	2.52	658	3.10	716	3.73	771	4.43	823	5.16
9000	616	2.86	675	3.44	732	4.10	786	4.80	836	5.55
9500	636	3.22	693	3.82	747	4.48	800	5.20	849	5.97
10000	656	3.60	710	4.21	763	4.89	813	5.62	862	6.40
10500	675	4.02	727	4.64	778	5.32	827	6.07	874	6.86
11000	694	4.46	744	5.09	793	5.79	841	6.50	887	7.34
11500	713	4.93	761	5.57	808	6.27	854	7.03	899	7.84
CFM	Available External Static Pressure (in. wg)									
	1.2		1.4		1.6		1.8		2.0	
	RPM	BHP	RPM	BHP	RPM	BHP	RPM	BHP	RPM	BHP
7500	845	5.14	892	5.90	936	6.68	978	7.48	1018	8.31
8000	859	5.53	905	6.31	949	7.11	991	7.94	-	-
8500	872	5.93	918	6.73	961	7.56	1003	8.41	-	-
9000	884	6.34	930	7.16	973	8.01	-	-	-	-
9500	896	6.77	941	7.61	984	8.48	-	-	-	-
10000	908	7.22	953	8.08	-	-	-	-	-	-
10500	920	7.69	963	8.56	-	-	-	-	-	-
11000	931	8.18	-	-	-	-	-	-	-	-
11500	943	8.70	-	-	-	-	-	-	-	-
Standard Static Motor and Drive – 647 – 791 RPM, Max BHP 4.9					Medium Static Motor and Drive – 755 – 923 RPM, Max BHP 6.5					
High Static Motor and Drive – 827 – 1010 RPM, Max BHP 8.7					– Outside operating range					
<b>Boldface</b> – Field Supplied Drive					<i>ITALIC Boldface</i> – Field Supplied Drive with Medium Static Motor					

## FAN PERFORMANCE (cont.)

**Table 20 – PULLEY ADJUSTMENT - HORIZONTAL**

UNIT	MOTOR/DRIVE COMBO	MOTOR PULLEY TURNS OPEN										
		0	0.5	1	1.5	2	2.5	3	3.5	4	4.5	5
18	Standard Static	680	663	647	630	614	597	580	564	547	531	514
	Medium Static	780	763	747	730	714	697	680	664	647	631	614
	High Static	912	895	879	862	846	829	812	796	779	763	746
21	Standard Static	822	802	782	762	742	722	702	682	662	642	622
	Medium Static	879	862	846	829	813	796	779	763	746	730	713
	High Static	1078	1058	1039	1019	1000	980	960	941	921	902	882
25	Standard Static	863	846	828	811	794	777	759	742	725	707	690
	Medium Static	1021	1002	984	965	947	928	909	891	872	854	835
	High Static	1176	1153	1129	1106	1082	1059	1035	1012	988	965	941
29	Standard Static	N/A	N/A	N/A	N/A	N/A	N/A	N/A	N/A	N/A	N/A	N/A
	Medium Static	923	906	889	873	856	839	822	805	789	772	755
	High Static	1010	992	973	955	937	919	900	882	864	845	827

**NOTE:** Do not adjust pulley further than 5 turns open.

N/A – Not Available

■ – Factory settings



# ELECTRICAL INFORMATION

## Legend and Notes

### LEGEND:

- BRKR - Circuit breaker
- CO - Convenience outlet
- DISC - Disconnect
- FLA - Full load amps
- LRA - Locked rotor amps
- MCA - Minimum circuit amps
- PE - Power exhaust
- PWRD CO - Powered convenient outlet
- UNPWR CO - Unpowered convenient outlet



### NOTES:

1. In compliance with NEC requirements for multimotor and combination load equipment (refer to NEC Articles 430 and 440), the overcurrent protective device for the unit shall be fuse or HACR breaker. Canadian units may be fuse or circuit breaker.
2. **Unbalanced 3-Phase Supply Voltage**  
Never operate a motor where a phase imbalance in supply voltage is greater than 2%. Use the following formula to determine the percentage of voltage imbalance.

$$\% \text{ Voltage Imbalance} = 100 \times \frac{\text{max voltage deviation from average voltage}}{\text{average voltage}}$$

Example: Supply voltage is 230-3-60



- AB = 224 v
- BC = 231 v
- AC = 226 v

$$\begin{aligned} \text{Average Voltage} &= \frac{(224 + 231 + 226)}{3} = \frac{681}{3} \\ &= 227 \end{aligned}$$

Determine maximum deviation from average voltage.

$$(AB) 227 - 224 = 3 \text{ v}$$

$$(BC) 231 - 227 = 4 \text{ v}$$

$$(AC) 227 - 226 = 1 \text{ v}$$

Maximum deviation is 4 v.

Determine percent of voltage imbalance.

$$\begin{aligned} \% \text{ Voltage Imbalance} &= 100 \times \frac{4}{227} \\ &= 1.76\% \end{aligned}$$

This amount of phase imbalance is satisfactory as it is below the maximum allowable 2%.

**IMPORTANT:** If the supply voltage phase imbalance is more than 2%, contact your local electric utility company immediately.

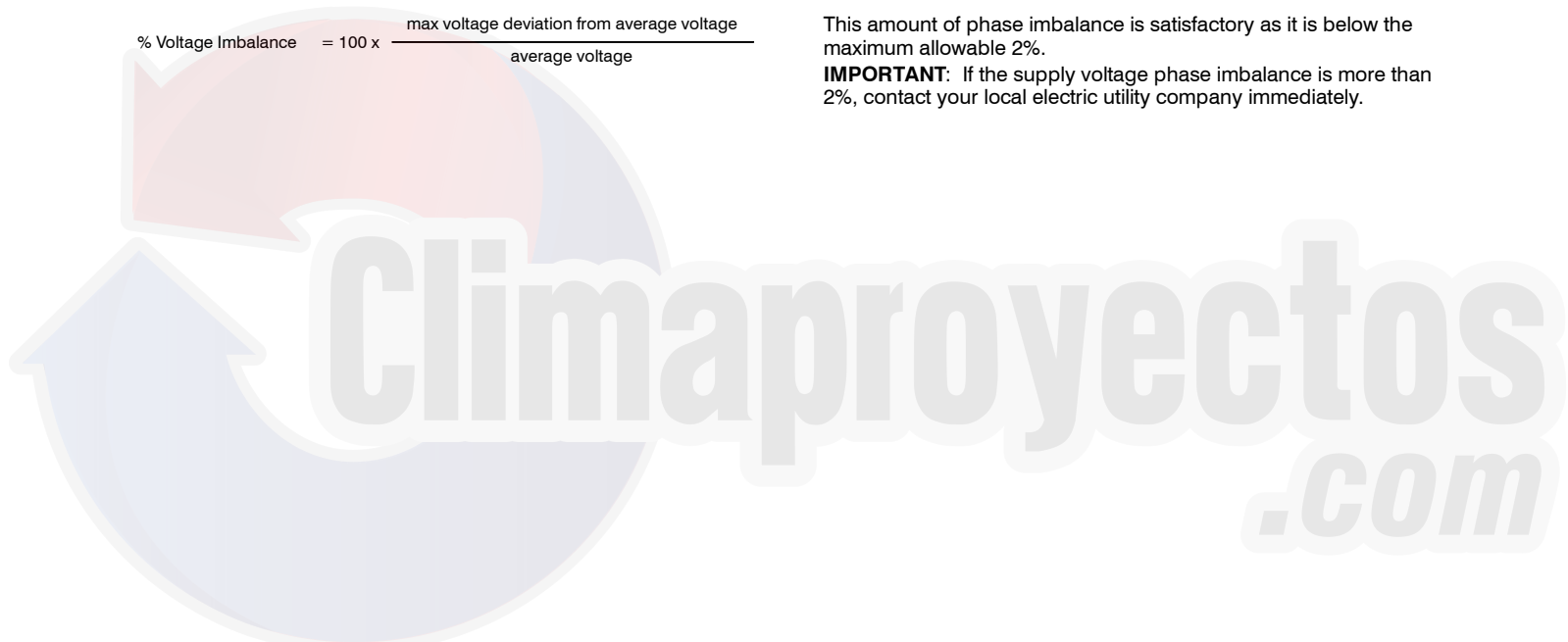

## ELECTRICAL INFORMATION

**Table 21 – 2-STAGE COOLING WITH SINGLE SPEED INDOOR FAN MOTOR**

**15 - 25 TONS**

UNIT	V-Ph-Hz	VOLTAGE RANGE		COMP 1		COMP 2		OFM (ea)		IFM		
				RLA	LRA	RLA	LRA	WATTS	FLA	TYPE	EFF at Full Load	FLA
		MIN	MAX									
558J*18	208-3-60	187	253	25.0	164	25.0	164	350	1.5	STD	88.6%	8.4
										MED	87.0%	10.6
										HIGH	82.9%	13.6
	230-3-60	187	253	25.0	164	25.0	164	350	1.5	STD	88.6%	8.3
										MED	87.0%	10.6
										HIGH	82.9%	12.7
	460-3-60	414	506	12.8	100	12.8	100	277	0.9	STD	88.6%	4.2
										MED	87.0%	5.3
										HIGH	82.9%	6.4
	575-3-60	518	633	9.6	78	9.6	78	397	0.6	STD	81.1%	2.8
										MED	81.1%	2.8
										HIGH	83.6%	5.6
558J*21	208-3-60	187	253	27.6	191	25.0	164	350	1.5	STD	87.0%	10.6
										MED	82.9%	13.6
										HIGH-High Eff.	89.5%	17.1
	230-3-60	187	253	27.6	191	25.0	164	350	1.5	STD	87.0%	10.6
										MED	82.9%	12.7
										HIGH-High Eff.	89.5%	17.1
	460-3-60	414	506	12.8	100	12.2	100	277	0.9	STD	87.0%	5.3
										MED	82.9%	6.4
										HIGH-High Eff.	89.5%	8.6
	575-3-60	518	633	9.6	78	9.0	78	397	0.6	STD	81.1%	2.8
										MED	83.6%	5.6
										HIGH-High Eff.	89.5%	7.6
558J*25	208-3-60	187	253	30.1	225	30.1	225	350	1.5	STD	82.9%	13.6
										MED-High Eff.	89.5%	17.1
										HIGH-High Eff.	91.7%	28.5
	230-3-60	187	253	30.1	225	30.1	225	350	1.5	STD	82.9%	12.7
										MED-High Eff.	89.5%	17.1
										HIGH-High Eff.	91.7%	28.5
	460-3-60	414	506	16.7	114	16.7	114	277	0.9	STD	82.9%	6.4
										MED-High Eff.	89.5%	8.6
										HIGH-High Eff.	91.7%	14.3
	575-3-60	518	633	12.2	80	12.2	80	397	0.6	STD	83.6%	5.6
										MED-High Eff.	89.5%	7.6
										HIGH-High Eff.	91.7%	9.5

See: "Legend and Notes" on page 38

Size 29 unit is not available with single speed indoor fan motor



# ELECTRICAL INFORMATION

**Table 22 – 2-STAGE COOLING WITH 2-SPEED INDOOR FAN MOTOR**

**15 - 25 TONS**

UNIT	V-Ph-Hz	VOLTAGE RANGE		COMP 1		COMP 2		OFM (ea)		IFM		
		MIN	MAX	RLA	LRA	RLA	LRA	WATTS	FLA	TYPE	EFF at Full Load	FLA
558J*18	208-3-60	187	253	25.0	164	25.0	164	350	1.5	STD	85.0%	8.6
										MED	81.5%	10.8
										HIGH	83.6%	13.6
	230-3-60	187	253	25.0	164	25.0	164	350	1.5	STD	85.0%	7.8
										MED	81.5%	9.8
										HIGH	83.6%	12.7
	460-3-60	414	506	12.8	100	12.8	100	277	0.9	STD	85.0%	3.8
										MED	81.5%	4.9
										HIGH	83.6%	6.4
	575-3-60	518	633	9.6	78	9.6	78	397	0.6	STD	81.1%	4.5
										MED	81.1%	4.5
										HIGH	83.6%	6.2
558J*21	208-3-60	187	253	27.6	191	25.0	164	350	1.5	STD	81.5%	10.8
										MED	83.6%	13.6
										HIGH	89.5%	17.1
	230-3-60	187	253	27.6	191	25.0	164	350	1.5	STD	81.5%	9.8
										MED	83.6%	12.7
										HIGH	89.5%	17.1
	460-3-60	414	506	12.8	100	12.2	100	277	0.9	STD	81.5%	4.9
										MED	83.6%	6.4
										HIGH	89.5%	8.6
	575-3-60	518	633	9.6	78	9.0	78	397	0.6	STD	81.1%	4.5
										MED	83.6%	6.2
										HIGH	89.5%	7.6
558J*25	208-3-60	187	253	30.1	225	30.1	225	350	1.5	STD	83.6%	13.6
										MED	89.5%	17.1
										HIGH	91.7%	28.5
	230-3-60	187	253	30.1	225	30.1	225	350	1.5	STD	83.6%	12.7
										MED	89.5%	17.1
										HIGH	91.7%	28.5
	460-3-60	414	506	16.7	114	16.7	114	277	0.9	STD	83.6%	6.4
										MED	89.5%	8.6
										HIGH	91.7%	14.3
	575-3-60	518	633	12.2	80	12.2	80	397	0.6	STD	83.6%	6.2
										MED	89.5%	7.6
										HIGH	91.7%	9.5
558J*29	208-3-60	187	253	48.1	245	33.3	239	350	1.5	STD	83.6%	13.6
										MED	89.5%	17.1
										HIGH	91.7%	28.5
	230-3-60	187	253	48.1	245	33.3	239	350	1.5	STD	83.6%	12.7
										MED	89.5%	17.1
										HIGH	91.7%	28.5
	460-3-60	414	506	18.6	125	17.9	125	277	0.9	STD	83.6%	6.4
										MED	89.5%	8.6
										HIGH	91.7%	14.3
	575-3-60	518	633	14.7	100	12.8	80	397	0.6	STD	83.6%	6.2
										MED	89.5%	7.6
										HIGH	91.7%	9.5

See: "Legend and Notes" on page 38

# ELECTRIC HEAT - ELECTRICAL INFORMATION

Table 23 – 558J\*18-21

## SINGLE SPEED INDOOR FAN MOTOR

Model Number 558J*	NOM. V-Ph-Hz	IFM TYPE	Electric Heater Part Number CRHEATERXXXXXX	Nominal (kW)	Application (kW)	Application Output (MBH)	Single Point or Junction Kit Part Number CRSINGLEXXXXA00				
							NO C.O. Or Unpowered C.O.		w/PWRD C.O.		
							NO P.E.	w/ P.E. (pwrd fr/unit)	NO P.E.	w/ P.E. (pwrd fr/unit)	
18	208/230-3-60	STD	270A00	25.0	18.8/23.0	64.1/78.3	-	-	-	-	
			271A00	50.0	37.6/45.9	128.1/156.7	056	056	056	056	
			272A00	75.0	56.3/68.9	192.2/235.0	056	056	056	056	
		MED	270A00	25.0	18.8/23.0	64.1/78.3	-	-	-	-	
			271A00	50.0	37.6/45.9	128.1/156.7	056	056	056	056	
			272A00	75.0	56.3/68.9	192.2/235.0	056	056	056	056	
		HIGH	270A00	25.0	18.8/23.0	64.1/78.3	-	-	-	-	
			271A00	50.0	37.6/45.9	128.1/156.7	056	056	056	056	
			272A00	75.0	56.3/68.9	192.2/235.0	056	056	056	056	
	460-3-60	STD	273A00	25.0	23.0	78.3	-	-	-	-	
			274A00	50.0	45.9	156.7	-	057	057	057	
			275A00	75.0	68.9	235.0	057	057	057	057	
		MED	273A00	25.0	23.0	78.3	-	-	-	-	
			274A00	50.0	45.9	156.7	057	057	057	057	
			275A00	75.0	68.9	235.0	057	057	057	057	
		HIGH	273A00	25.0	23.0	78.3	-	-	-	-	
			274A00	50.0	45.9	156.7	057	057	057	057	
			275A00	75.0	68.9	235.0	057	057	057	057	
	575-3-60	STD	276A00	24.8	22.8	77.7	-	-	-	-	
			277A00	49.6	45.6	155.4	-	-	-	057	
			278A00	74.4	68.3	233.1	057	057	057	057	
		MED	276A00	24.8	22.8	77.7	-	-	-	-	
			277A00	49.6	45.6	155.4	-	-	-	057	
			278A00	74.4	68.3	233.1	057	057	057	057	
		HIGH	276A00	24.8	22.8	77.7	-	-	-	-	
			277A00	49.6	45.6	155.4	-	057	-	057	
			278A00	74.4	68.3	233.1	057	057	057	057	
	21	208/230-3-60	STD	270A00	25.0	18.8/23.0	64.1/78.3	-	-	-	-
				271A00	50.0	37.6/45.9	128.1/156.7	056	056	056	056
				272A00	75.0	56.3/68.9	192.2/235.0	056	056	056	056
MED			270A00	25.0	18.8/23.0	64.1/78.3	-	-	-	-	
			271A00	50.0	37.6/45.9	128.1/156.7	056	056	056	056	
			272A00	75.0	56.3/68.9	192.2/235.0	056	056	056	056	
HIGH - High Efficiency			270A00	25.0	18.8/23.0	64.1/78.3	-	-	-	-	
			271A00	50.0	37.6/45.9	128.1/156.7	056	056	056	056	
			272A00	75.0	56.3/68.9	192.2/235.0	056	056	056	056	
460-3-60		STD	R273A00	25.0	23.0	78.3	-	-	-	-	
			274A00	50.0	45.9	156.7	057	057	057	057	
			275A00	75.0	68.9	235.0	057	057	057	057	
		MED	273A00	25.0	23.0	78.3	-	-	-	-	
			274A00	50.0	45.9	156.7	057	057	057	057	
			275A00	75.0	68.9	235.0	057	057	057	057	
		HIGH - High Efficiency	273A00	25.0	23.0	78.3	-	-	-	-	
			274A00	50.0	45.9	156.7	057	057	057	057	
			275A00	75.0	68.9	235.0	057	057	057	057	
575-3-60		STD	276A00	24.8	22.8	77.7	-	-	-	-	
			277A00	49.6	45.6	155.4	-	-	-	057	
			278A00	74.4	68.3	233.1	057	057	057	057	
		MED	276A00	24.8	22.8	77.7	-	-	-	-	
			277A00	49.6	45.6	155.4	-	057	-	057	
			278A00	74.4	68.3	233.1	057	057	057	057	
		HIGH - High Efficiency	276A00	24.8	22.8	77.7	-	-	-	-	
			277A00	49.6	45.6	155.4	-	057	057	057	
			278A00	74.4	68.3	233.1	057	057	057	057	

See: "Legend and Notes" on page 38

# ELECTRIC HEAT - ELECTRICAL INFORMATION

Table 23 - 558J\*25 (CONT.)

## SINGLE SPEED INDOOR FAN MOTOR

Model Number 558J*	NOM. V-Ph-Hz	IFM TYPE	Electric Heater Part Number CRHEATERXXXXXX	Nominal (kW)	Application (kW)	Application Output (MBH)	Single Point or Junction Kit Part Number CRSINGLEXXXXA00			
							NO C.O. Or Unpowered C.O.		w/PWRD C.O.	
							NO P.E.	w/ P.E. (pwrd fr/unit)	NO P.E.	w/ P.E. (pwrd fr/unit)
25	208/203-3-60	STD	270A00	25.0	18.8/23.0	64.1/78.3	-	-	-	-
			271A00	50.0	37.6/45.9	128.1/156.7	056	056	056	056
			272A00	75.0	56.3/68.9	192.2/235.0	056	056	056	056
		MED-High Efficiency	270A00	25.0	18.8/23.0	64.1/78.3	-	-	-	-
			271A00	50.0	37.6/45.9	128.1/156.7	056	056	056	056
			272A00	75.0	56.3/68.9	192.2/235.0	056	056	056	056
		HIGH-High Efficiency	270A00	25.0	18.8/23.0	64.1/78.3	-	056	-	056
			271A00	50.0	37.6/45.9	128.1/156.7	056	056	056	056
			272A00	75.0	56.3/68.9	192.2/235.0	056	056	056	056
	460-3-60	STD	273A00	25.0	23.0	78.3	-	-	-	-
			274A00	50.0	45.9	156.7	057	057	057	057
			275A00	75.0	68.9	235.0	057	057	057	057
		MED-High Efficiency	273A00	25.0	23.0	78.3	-	-	-	-
			274A00	50.0	45.9	156.7	057	057	057	057
			275A00	75.0	68.9	235.0	057	057	057	057
		HIGH-High Efficiency	273A00	25.0	23.0	78.3	-	-	-	057
			274A00	50.0	45.9	156.7	057	057	057	057
			275A00	75.0	68.9	235.0	057	057	057	057
	575-3-60	STD	276A00	24.8	22.8	77.7	-	-	-	-
			277A00	49.6	45.6	155.4	-	057	-	057
			278A00	74.4	68.3	233.1	057	057	057	057
		MED-High Efficiency	276A00	24.8	22.8	77.7	-	-	-	-
			277A00	49.6	45.6	155.4	-	057	057	057
			278A00	74.4	68.3	233.1	057	057	057	057
		HIGH-High Efficiency	276A00	24.8	22.8	77.7	-	-	-	-
			277A00	49.6	45.6	155.4	057	057	057	057
			278A00	74.4	68.3	233.1	057	057	057	057

See: "Legend and Notes" on page 38

# ELECTRIC HEAT - ELECTRICAL INFORMATION

Table 24 – 558J\*18-21

## 2-SPEED INDOOR FAN MOTOR

Model Number 558J*	NOM. V-Ph-Hz	IFM TYPE	Electric Heater Part Number CRHEATERXXXXXX	Nominal (kW)	Application (kW)	Application Output (MBH)	Single Point or Junction Kit Part Number CRSINGLEXXXXA00				
							NO C.O. Or Unpowered C.O.		w/PWRD C.O.		
							NO P.E.	w/ P.E. (pwrd fr/unit)	NO P.E.	w/ P.E. (pwrd fr/unit)	
18	208/230-3-60	STD	270A00	25.0	18.8/23.0	64.1/78.3	-	-	-	-	
			271A00	50.0	37.6/45.9	128.1/156.7	056	056	056	056	
			272A00	75.0	56.3/68.9	192.2/235.0	056	056	056	056	
		MED	270A00	25.0	18.8/23.0	64.1/78.3	-	-	-	-	
			271A00	50.0	37.6/45.9	128.1/156.7	056	056	056	056	
			272A00	75.0	56.3/68.9	192.2/235.0	056	056	056	056	
		HIGH	270A00	25.0	18.8/23.0	64.1/78.3	-	-	-	-	
			271A00	50.0	37.6/45.9	128.1/156.7	056	056	056	056	
			272A00	75.0	56.3/68.9	192.2/235.0	056	056	056	056	
	460-3-60	STD	273A00	25.0	23.0	78.3	-	-	-	-	
			274A00	50.0	45.9	156.7	-	057	057	057	
			275A00	75.0	68.9	235.0	057	057	057	057	
		MED	273A00	25.0	23.0	78.3	-	-	-	-	
			274A00	50.0	45.9	156.7	057	057	057	057	
			275A00	75.0	68.9	235.0	057	057	057	057	
		HIGH	273A00	25.0	23.0	78.3	-	-	-	-	
			274A00	50.0	45.9	156.7	057	057	057	057	
			275A00	75.0	68.9	235.0	057	057	057	057	
	575-3-60	STD	276A00	24.8	22.8	77.7	-	-	-	-	
			277A00	49.6	45.6	155.4	-	057	-	057	
			278A00	74.4	68.3	233.1	057	057	057	057	
		MED	276A00	24.8	22.8	77.7	-	-	-	-	
			277A00	49.6	45.6	155.4	-	057	-	057	
			278A00	74.4	68.3	233.1	057	057	057	057	
		HIGH	276A00	24.8	22.8	77.7	-	-	-	-	
			277A00	49.6	45.6	155.4	-	057	-	057	
			278A00	74.4	68.3	233.1	057	057	057	057	
	21	208/230-3-60	STD	270A00	25.0	18.8/23.0	64.1/78.3	-	-	-	-
				271A00	50.0	37.6/45.9	128.1/156.7	056	056	056	056
				272A00	75.0	56.3/68.9	192.2/235.0	056	056	056	056
			MED	270A00	25.0	18.8/23.0	64.1/78.3	-	-	-	-
				271A00	50.0	37.6/45.9	128.1/156.7	056	056	056	056
				272A00	75.0	56.3/68.9	192.2/235.0	056	056	056	056
			HIGH	270A00	25.0	18.8/23.0	64.1/78.3	-	-	-	-
				271A00	50.0	37.6/45.9	128.1/156.7	056	056	056	056
				272A00	75.0	56.3/68.9	192.2/235.0	056	056	056	056
460-3-60		STD	273A00	25.0	23.0	78.3	-	-	-	-	
			274A00	50.0	45.9	156.7	057	057	057	057	
			275A00	75.0	68.9	235.0	057	057	057	057	
		MED	273A00	25.0	23.0	78.3	-	-	-	-	
			274A00	50.0	45.9	156.7	057	057	057	057	
			275A00	75.0	68.9	235.0	057	057	057	057	
		HIGH	273A00	25.0	23.0	78.3	-	-	-	-	
			274A00	50.0	45.9	156.7	057	057	057	057	
			275A00	75.0	68.9	235.0	057	057	057	057	
575-3-60		STD	276A00	24.8	22.8	77.7	-	-	-	-	
			277A00	49.6	45.6	155.4	-	057	-	057	
			278A00	74.4	68.3	233.1	057	057	057	057	
		MED	276A00	24.8	22.8	77.7	-	-	-	-	
			277A00	49.6	45.6	155.4	-	057	-	057	
			278A00	74.4	68.3	233.1	057	057	057	057	
		HIGH	276A00	24.8	22.8	77.7	-	-	-	-	
			277A00	49.6	45.6	155.4	-	057	057	057	
			278A00	74.4	68.3	233.1	057	057	057	057	

See: "Legend and Notes" on page 38

# ELECTRIC HEAT - ELECTRICAL INFORMATION

Table 24 - 558J\*25-29 (CONT.)

## 2-SPEED INDOOR FAN MOTOR

Model Number 558J*	NOM. V-Ph-Hz	IFM TYPE	Electric Heater Part Number CRHEATERXXXXXX	Nominal (kW)	Application (kW)	Application Output (MBH)	Single Point or Junction Kit Part Number CRSINGLEXXXXA00			
							NO C.O. Or Unpowered C.O.		w/PWRD C.O.	
							NO P.E.	w/ P.E. (pwrd fr/unit)	NO P.E.	w/ P.E. (pwrd fr/unit)
25	208/203-3-60	STD	270A00	25.0	18.8/23.0	64.1/78.3	-	-	-	-
			271A00	50.0	37.6/45.9	128.1/156.7	056	056	056	056
			272A00	75.0	56.3/68.9	192.2/235.0	056	056	056	056
		MED	270A00	25.0	18.8/23.0	64.1/78.3	-	-	-	-
			271A00	50.0	37.6/45.9	128.1/156.7	056	056	056	056
			272A00	75.0	56.3/68.9	192.2/235.0	056	056	056	056
		HIGH	270A00	25.0	18.8/23.0	64.1/78.3	-	056	-	056
			271A00	50.0	37.6/45.9	128.1/156.7	056	056	056	056
			272A00	75.0	56.3/68.9	192.2/235.0	056	056	056	056
	460-3-60	STD	273A00	25.0	23.0	78.3	-	-	-	-
			274A00	50.0	45.9	156.7	057	057	057	057
			275A00	75.0	68.9	235.0	057	057	057	057
		MED	273A00	25.0	23.0	78.3	-	-	-	-
			274A00	50.0	45.9	156.7	057	057	057	057
			275A00	75.0	68.9	235.0	057	057	057	057
		HIGH	273A00	25.0	23.0	78.3	-	-	-	057
			274A00	50.0	45.9	156.7	057	057	057	057
			275A00	75.0	68.9	235.0	057	057	057	057
	575-3-60	STD	276A00	24.8	22.8	77.7	-	-	-	-
			277A00	49.6	45.6	155.4	-	057	-	057
			278A00	74.4	68.3	233.1	057	057	057	057
		MED	276A00	24.8	22.8	77.7	-	-	-	-
			277A00	49.6	45.6	155.4	-	057	057	057
			278A00	74.4	68.3	233.1	057	057	057	057
		HIGH	276A00	24.8	22.8	77.7	-	-	-	-
			277A00	49.6	45.6	155.4	057	057	057	057
			278A00	74.4	68.3	233.1	057	057	057	057
29	208/230-3-60	STD	270A00	25.0	18.8/23.0	64.1/78.3	056	056	056	056
			271A00	50.0	37.6/45.9	128.1/156.7	056	056	056	056
			272A00	75.0	56.3/68.9	192.2/235.0	056	056	056	056
		MED	270A00	25.0	18.8/23.0	64.1/78.3	056	056	056	056
			271A00	50.0	37.6/45.9	128.1/156.7	056	056	056	056
			272A00	75.0	56.3/68.9	192.2/235.0	056	056	056	056
		HIGH	270A00	25.0	18.8/23.0	64.1/78.3	056	056	056	056
			271A00	50.0	37.6/45.9	128.1/156.7	056	056	056	056
			272A00	75.0	56.3/68.9	192.2/235.0	056	056	056	056
	460-3-60	STD	273A00	25.0	23.0	78.3	-	-	-	-
			274A00	50.0	45.9	156.7	057	057	057	057
			275A00	75.0	68.9	235.0	057	057	057	057
		MED	273A00	25.0	23.0	78.3	-	-	-	057
			274A00	50.0	45.9	156.7	057	057	057	057
			275A00	75.0	68.9	235.0	057	057	057	057
		HIGH	273A00	25.0	23.0	78.3	-	057	057	057
			274A00	50.0	45.9	156.7	057	057	057	057
			275A00	75.0	68.9	235.0	057	057	057	057
	575-3-60	STD	276A00	24.8	22.8	77.7	-	-	-	-
			277A00	49.6	45.6	155.4	-	057	-	057
			278A00	74.4	68.3	233.1	057	057	057	057
		MED	276A00	24.8	22.8	77.7	-	-	-	-
			277A00	49.6	45.6	155.4	-	057	057	057
			278A00	74.4	68.3	233.1	057	057	057	057
		HIGH	276A00	24.8	22.8	77.7	-	-	-	-
			277A00	49.6	45.6	155.4	057	057	057	057
			278A00	74.4	68.3	233.1	057	057	057	057

See: "Legend and Notes" on page 38



# ELECTRICAL INFORMATION

**Table 25 - UNIT WIRE/FUSE OR HACR BREAKER SIZING DATA (cont)**

UNIT	IFM TYPE	ELEC. HTR				NO C.O. or UNPWR C.O.										w/ PWRD C.O.														
		CRHEATER*****	Nom (kW)	FLA	MCA	NO PE.			w/ R.E. (pwrd fr/unit)			NO PE.			w/ R.E. (pwrd fr/unit)			NO PE.			w/ R.E. (pwrd fr/unit)									
						MAX FUSE or BRKR	DISC. SIZE FLA	DISC. SIZE LRA	MCA	MAX FUSE or BRKR	DISC. SIZE FLA	DISC. SIZE LRA	MCA	MAX FUSE or BRKR	DISC. SIZE FLA	DISC. SIZE LRA	MCA	MAX FUSE or BRKR	DISC. SIZE FLA	DISC. SIZE LRA	MCA	MAX FUSE or BRKR	DISC. SIZE FLA	DISC. SIZE LRA						
558J*21	NO M, V-P-H-Z	STD	NONE	-	-	76.1	100	80	453	87.9	100	93	473	80.9	100	85	458	92.7	100	100	100	99	478	99/100	100/110	99.1/109.1	100/110	175/175	151/170	478/478
			270A00	18.8/25.0	52.1/60.1	78.4/88.4	100/100	80/81	453/453	93.1/103.1	100/110	93/95	473/473	84.4/94.4	100/100	100/100	85/87	458/458	99.1/109.1	100/110	100/110	100/110	99/100	478/478	99/100	100/110	175/175	151/170	478/478	
			271A00	37.6/50.0	104.2/120.3	143.5/133.6	150/150	132/151	453/453	158.3/148.3	175/175	148/164	473/473	149.5/139.6	150/150	150/150	138/156	458/458	164.3/154.3	175/175	175/175	175/175	151/170	478/478	151/170	175/175	175/175	151/170	478/478	
			272A00	56.3/75.0	156.4/180.4	169.7/193.7	200/225	192/220	453/453	184.4/200.4	200/225	206/233	473/473	175.7/199.7	200/225	200/225	198/225	458/458	190.4/214.4	200/225	200/225	200/225	211/239	478/478	211/239	200/225	200/225	200/225	211/239	478/478
			NONE	-	-	79.1/78.2	100/100	83/82	455	90.9/90.8	100/100	97/96	475	83.9/83.0	100/100	100/100	89/88	460	95.7/94.8	110/110	110/110	110/110	102/101	480	102/101	110/110	110/110	110/110	102/101	480
			270A00	18.8/25.0	52.1/60.1	82.1/91.0	100/100	83/84	455/455	96.9/105.8	100/110	97/97	475/475	88.1/97.0	100/100	100/100	89/89	460/460	102.9/111.8	110/110	110/110	110/110	102/103	480/480	102/103	110/110	110/110	110/110	102/103	480/480
			271A00	37.6/50.0	104.2/120.3	147.3/136.2	150/150	135/153	455/455	162.0/150.9	175/175	149/167	475/475	153.3/142.2	175/175	175/175	141/158	460/460	168.0/156.9	175/175	175/175	175/175	155/172	480/480	155/172	175/175	175/175	155/172	480/480	
			272A00	56.3/75.0	156.4/180.4	173.4/196.3	200/225	198/222	455/455	188.2/211.0	200/225	209/236	475/475	179.4/202.3	200/225	200/225	201/228	460/460	194.2/217.0	200/225	200/225	200/225	215/241	480/480	215/241	200/225	200/225	200/225	215/241	480/480
			NONE	-	-	82.6	100	87	451	94.4	110	101	471	87.4	100	100	93	456	99.2	125	125	125	106	476	106	125	125	125	106	476
			270A00	18.8/25.0	52.1/60.1	86.5/96.5	100/100	87/89	451/451	101.3/111.3	110/125	101/102	471/471	92.5/102.5	100/110	100/110	93/94	456/456	107.3/117.3	125/125	125/125	125/125	106/108	476/476	106/108	125/125	125/125	125/125	106/108	476/476
271A00	37.6/50.0	104.2/120.3	151.6/141.7	175/175	139/158	451/451	168.4/156.4	175/175	153/172	471/471	157.6/147.7	175/175	175/175	145/164	456/456	172.4/162.4	175/175	175/175	175/175	159/177	476/476	159/177	175/175	175/175	159/177	476/476				
272A00	56.3/75.0	156.4/180.4	177.8/201.8	200/225	200/227	451/451	192.5/216.5	200/250	213/241	471/471	183.8/207.8	200/250	200/250	205/233	456/456	198.5/222.5	200/250	200/250	200/250	219/246	476/476	219/246	200/250	200/250	200/250	219/246	476/476			
460-3-60	STD	NONE	-	-	37.1	45	39	251	43.3	50	46	263	39.3	50	42	253	45.5	50	50	50	49	265	50	50	50	50	50	265		
		273A00	25.0	30.1	44.3	80	41	251	52.0	60	48	263	47.0	60	43	253	54.8	60	60	60	50	265	60	60	60	60	50	265		
		274A00	50.0	60.1	66.7	80	75	251	74.5	80	82	263	69.5	80	78	253	77.2	80	80	80	85	265	80	80	80	80	85	265		
		275A00	75.0	90.2	96.8	100	110	251	104.6	110	117	263	99.6	110	112	253	107.3	110	110	110	119	265	110	110	110	110	119	265		
		NONE	-	-	38.2	50	40	252	44.4	50	47	264	40.4	50	43	254	46.6	50	50	50	50	49	266	50	50	50	50	266		
		273A00	25.0	30.1	45.6	80	42	252	53.4	60	49	264	48.4	60	45	254	56.1	60	60	60	52	266	60	60	60	60	52	266		
		274A00	50.0	60.1	68.1	80	76	252	75.9	80	84	264	70.9	80	79	254	78.6	80	80	80	86	266	80	80	80	80	86	266		
		275A00	75.0	90.2	98.2	100	111	252	106.0	125	118	264	101.0	110	114	252	108.7	110	110	110	121	266	110	110	110	110	121	266		
		NONE	-	-	40.4	50	43	250	46.6	50	50	262	42.6	50	45	252	48.8	50	50	50	52	264	50	50	50	50	52	264		
		273A00	25.0	30.1	48.4	80	45	250	56.1	60	52	262	51.1	60	47	252	58.9	60	60	60	54	264	60	60	60	60	54	264		
575-3-60	STD	NONE	-	-	26.2	30	27	186	31.0	40	33	194	27.9	40	29	188	32.7	40	40	35	196	40	35	40	40	35	196			
		276A00	24.8	23.9	33.4	35	31	186	39.4	40	36	194	35.5	40	33	188	41.5	40	40	45	196	40	45	40	45	38	196			
		277A00	49.6	47.7	63.1	70	58	186	69.1	70	64	194	65.3	70	60	188	71.3	80	80	80	66	196	80	80	80	66	196			
		278A00	74.4	71.6	75.1	80	86	186	81.1	90	91	194	77.2	80	88	188	83.2	90	90	90	93	196	90	90	90	93	196			
		NONE	-	-	29.0	35	31	200	33.8	40	36	208	30.7	40	33	202	35.5	40	40	45	38	210	40	45	40	45	38	210		
		276A00	24.8	23.9	36.9	40	34	200	42.9	45	39	208	39.0	40	36	202	45.0	40	40	50	41	210	40	50	50	41	210			
		277A00	49.6	47.7	66.6	70	61	200	72.6	80	67	208	68.8	70	63	202	74.8	80	80	80	69	210	80	80	80	69	210			
		278A00	74.4	71.6	78.6	90	89	200	84.6	90	94	208	80.7	90	91	202	86.7	90	90	90	96	210	90	90	90	96	210			
		NONE	-	-	31.0	40	33	198	35.8	45	38	206	32.7	40	35	200	37.5	40	40	45	40	208	40	45	40	45	40	208		
		276A00	24.8	23.9	39.4	40	36	198	45.4	50	42	206	41.5	40	38	200	47.5	40	40	50	44	208	40	50	50	44	208			
277A00	49.6	47.7	69.1	70	64	198	75.1	80	69	206	71.3	70	66	200	77.3	80	80	80	71	208	80	80	80	71	208					
278A00	74.4	71.6	81.1	90	91	198	87.1	90	97	206	83.2	80	93	200	89.2	90	90	90	99	208	90	90	90	99	208					

See: "Legend and Notes" on page 38





# ELECTRICAL INFORMATION

**Table 26 – UNIT WIRE/FUSE OR HACR BREAKER SIZING DATA WITH FACTORY INSTALLED 2 SPEED INDOOR FAN OPTION**

UNIT	IFM TYPE	ELEC. HTR				NO C.O. or UNPWR C.O.						w/ PWRD C.O.					
		CRHEATER*****	Nom (kW)	FLA	NO PE.			w/ PE. (pwrd fr/unit)			NO PE.			w/ PE. (pwrd fr/unit)			
					MAX FUSE or BRKR	FLA	DISC. SIZE	MCA	MAX FUSE or BRKR	MCA	DISC. SIZE	FLA	LRA	MAX FUSE or BRKR	MCA	DISC. SIZE	FLA
558J*18	STD	NONE	-	-	73/72	390	86/85	410	74.2/73.4	90/90	78/77	395	86.0/85.2	100/100	92/91	415	
		270A00	18.8/25.0	52.1/60.1	73/78	390/390	90/100	86/92	410/410	81.9/90.9	90/100	78/84	395/395	96.6/105.6	100/110	92/97	415/415
		271A00	37.6/50.0	104.2/120.3	130/147	390/390	175/150	143/161	410/410	147.0/136.1	150/150	135/153	395/395	161.8/150.8	175/175	149/166	415/415
		272A00	56.3/75.0	156.4/180.4	190/216	390/390	200/225	203/230	410/410	175.2/196.2	200/225	195/222	395/395	187.9/210.9	200/225	209/236	415/415
		NONE	-	-	75/74	414	90/90	89/88	434	76.4/75.4	100/100	81/79	419	86.2/87.2	100/100	94/93	439
		270A00	18.8/25.0	52.1/60.1	75/80	414/414	90/90	89/94	434/434	84.6/93.4	100/100	81/86	419/419	99.4/108.1	100/110	94/99	439/439
460-3-60	MED	271A00	37.6/50.0	104.2/120.3	132/150	414/414	146/163	434/434	149.8/138.6	150/150	138/155	419/419	164.5/153.3	175/175	151/169	439/439	
		272A00	56.3/75.0	156.4/180.4	192/219	414/414	200/225	206/232	434/434	175.9/196.7	200/225	198/224	419/419	200/225	211/238	439/439	
		NONE	-	-	78/77	425	90/90	92/91	445	79.2/78.3	100/100	84/83	430	91.0/90.1	100/100	97/96	450
		270A00	18.8/25.0	52.1/60.1	78/84	425/425	90/100	92/97	445/445	88.1/97.0	100/110	84/89	430/430	102.9/111.8	110/125	97/103	450/450
		271A00	37.6/50.0	104.2/120.3	135/153	425/425	150/150	149/167	445/445	153.3/142.2	175/175	141/158	430/430	166.0/156.9	175/175	155/172	450/450
		272A00	56.3/75.0	156.4/180.4	196/222	425/425	200/225	209/236	445/445	179.4/202.3	200/225	201/228	430/430	194.2/217.0	200/250	215/241	450/450
575-3-60	STD	NONE	-	-	37	233	44	245	37.5	50/50	39	235	43.7	50/50	47	247	
		273A00	25.0	30.1	39	233	46	245	45.1	60/60	42	235	52.9	60/60	49	247	
		274A00	50.0	60.1	73	233	81	245	67.6	75.4	80/80	76	235	80.0	80/80	83	247
		275A00	75.0	90.2	108	233	115	245	97.7	105.5	100/100	111	235	110	118	247	
		NONE	-	-	38	245	45	45	257	38.6	50/50	41	247	44.8	50/50	48	259
		273A00	25.0	30.1	40	245	47	257	46.5	54.3	50/50	43	247	54.3	60/60	50	259
575-3-60	MED	274A00	50.0	60.1	75	245	84	262	69.0	80/80	77	247	76.7	80/80	84	259	
		275A00	75.0	90.2	109	245	116	257	99.1	110	112	247	106.8	110	119	259	
		NONE	-	-	42	250	50	47	40.1	50/50	42	252	46.3	50/50	50	264	
		273A00	25.0	30.1	42	250	49	262	48.4	56.1	45	252	56.1	60/60	52	264	
		274A00	50.0	60.1	76	250	80	84	70.9	78.6	80/80	79	252	80.0	80/80	86	264
		275A00	75.0	90.2	111	250	125	118	101.0	110	114	252	108.7	125	121	264	
575-3-60	STD	NONE	-	-	29	184	35	192	29.6	40/40	31	186	34.4	40/40	37	194	
		276A00	24.8	23.9	33	184	38	192	37.6	43.6	35	186	43.6	45.0	40	194	
		277A00	49.6	47.7	60	184	66	192	67.4	73.4	70/70	62	186	80.0	80.0	68	194
		278A00	74.4	71.6	88	184	93	192	79.4	85.4	90	89	186	85.4	90	95	194
		NONE	-	-	29	184	35	192	29.6	34.4	35.0	31	186	34.4	40.0	37	194
		276A00	24.8	23.9	33	184	38	192	37.6	43.6	40.0	35	186	43.6	45.0	40	194
575-3-60	MED	277A00	49.6	47.7	60	184	66	67.4	73.4	70.0	62	186	73.4	80.0	68	194	
		278A00	74.4	71.6	88	184	93	192	79.4	85.4	90	89	186	85.4	90	95	194
		NONE	-	-	35	184	35	192	29.6	34.4	35.0	31	186	34.4	40.0	37	194
		276A00	24.8	23.9	33	184	38	192	37.6	43.6	40.0	35	186	43.6	45.0	40	194
		277A00	49.6	47.7	60	184	66	192	67.4	73.4	70.0	62	186	73.4	80.0	68	194
		278A00	74.4	71.6	88	184	93	192	79.4	85.4	90	89	186	85.4	90	95	194
575-3-60	HIGH	NONE	-	-	31	198	37	206	31.3	40/40	33	200	36.1	45.0	39	208	
		276A00	24.8	23.9	35	198	40	206	39.8	45.8	40.0	37	200	45.8	50.0	42	208
		277A00	49.6	47.7	62	198	68	206	69.5	75.5	70.0	64	200	75.5	80.0	69	208
		278A00	74.4	71.6	89	198	95	206	81.5	87.5	90	91	200	87.5	90	97	208
		NONE	-	-	31	198	37	206	31.3	36.1	40.0	33	200	36.1	45.0	39	208
		276A00	24.8	23.9	35	198	40	206	39.8	45.8	40.0	37	200	45.8	50.0	42	208

See: "Legend and Notes" on page 38



# ELECTRICAL INFORMATION

**Table 26 - UNIT WIRE/FUSE OR HACR BREAKER SIZING DATA WITH FACTORY INSTALLED 2 SPEED INDOOR FAN OPTION (cont.)**

UNIT	NO M. V-PH-HZ	ELEC. HTR										NO C.O. or UNPWR C.O.										w/ PWRD C.O.															
		IFM TYPE	CRHEATER*****	Nom (kW)	FLA	NO PE.			w/ P.E. (pwrd fr/unit)			NO PE.			w/ P.E. (pwrd fr/unit)			NO PE.			w/ P.E. (pwrd fr/unit)			NO PE.			w/ P.E. (pwrd fr/unit)										
						MCA	MAX FUSE or HACR BRKR	DISC. SIZE FLA LRA	MCA	MAX FUSE or HACR BRKR	DISC. SIZE FLA LRA	MCA	MAX FUSE or HACR BRKR	DISC. SIZE FLA LRA	MCA	MAX FUSE or HACR BRKR	DISC. SIZE FLA LRA	MCA	MAX FUSE or HACR BRKR	DISC. SIZE FLA LRA	MCA	MAX FUSE or HACR BRKR	DISC. SIZE FLA LRA	MCA	MAX FUSE or HACR BRKR	DISC. SIZE FLA LRA	MCA	MAX FUSE or HACR BRKR	DISC. SIZE FLA LRA								
58L25	460-3-60	STD	NONE	-	-	87.3/86.4	100/100	92/91	550	550	105/104	125/125	125/125	105/104	570	570	97/96	100/100	100/100	97/96	555	555	101	114	114	125/125	125/125	101	114	114	150.00	150.00	128	128	650	650	
			270A00	18.8/25.0	52.1/60.1	87.3/91.0	100/100	92/91	550/550	550/550	105/104	125/125	125/125	105/104	570/570	570/570	97/96	100/100	100/100	97/96	555/555	555/555	101/101	114/114	114/114	150/150	150/150	101/101	114/114	114/114	150/150	150/150	128/128	128/128	650/650	650/650	
			271A00	37.6/50.0	104.2/120.3	147.3/136.2	150/150	135/153	550/550	550/550	149/167	175/175	175/175	149/167	570/570	570/570	141/158	175/175	175/175	141/158	555/555	555/555	145/164	159/177	159/177	200/200	200/200	145/164	159/177	159/177	200/200	200/200	172/190	172/190	650/650	650/650	
			272A00	56.3/75.0	156.4/180.4	173.4/196.3	200/225	196/222	550/550	550/550	209/236	200/225	200/225	209/236	570/570	570/570	201/228	200/225	200/225	201/228	555/555	555/555	205/233	218/246	218/246	225/250	225/250	205/233	218/246	218/246	225/250	225/250	232/259	232/259	650/650	650/650	
			NONE	-	-	90.8	100	546	546	102.6	125	109	109	125	125	645	645	101	110	110	101	551	551	101	114	114	125.00	125.00	101	114	114	150.00	150.00	128	128	650	650
			270A00	18.8/25.0	52.1/60.1	90.8/96.5	100/100	96/96	546/546	546/546	102.6/111.3	125/125	109/109	125/125	125/125	566/566	566/566	101/101	125/125	125/125	101/101	551/551	551/551	101/101	114/114	114/114	150/150	150/150	101/101	114/114	114/114	150/150	150/150	128/128	128/128	650/650	650/650
			271A00	37.6/50.0	104.2/120.3	151.6/141.7	175/175	139/158	546/546	546/546	166.4/156.4	175/175	153/172	175/175	175/175	566/566	566/566	145/164	175/175	175/175	145/164	551/551	551/551	145/164	159/177	159/177	200/200	200/200	145/164	159/177	159/177	200/200	200/200	172/190	172/190	650/650	650/650
			272A00	56.3/75.0	156.4/180.4	177.8/201.8	200/225	200/227	546/546	546/546	192.5/216.5	200/250	213/241	200/250	200/250	566/566	566/566	205/233	200/225	200/225	205/233	551/551	551/551	205/233	218/246	218/246	225/250	225/250	205/233	218/246	218/246	225/250	225/250	232/259	232/259	650/650	650/650
58L25	460-3-60	STD	NONE	-	-	47.6	60	50	280	280	57	60	60	292	292	52	60.00	60.00	52	282	282	52	282	282	70.00	70.00	52	282	282	70.00	70.00	60	60	294	294		
			273A00	25.0	30.1	47.6	60	50	280	280	57	60	60	60	292	292	52	60.00	60.00	52	282	282	52	282	282	70.00	70.00	52	282	282	70.00	70.00	60	60	294	294	
			274A00	50.0	60.1	68.1	80	76	280	280	75.9	80	84	80	292	292	79	80.00	80.00	79	282	282	79	282	282	80.00	80.00	79	282	282	80.00	80.00	86	86	294	294	
			275A00	75.0	90.2	98.2	100	111	280	280	106.0	125	118	125	292	292	114	110	110	114	282	282	114	282	282	125	125	114	282	282	125	125	121	121	294	294	
			NONE	-	-	49.8	60	52	278	278	56.0	70	66	70	290	290	55	60.00	60.00	55	280	280	55	280	280	70.00	70.00	55	280	280	70.00	70.00	62	62	292	292	
			273A00	25.0	30.1	49.8	60	52	278	278	56.1	70	66	70	290	290	55	60.00	60.00	55	280	280	55	280	280	70.00	70.00	55	280	280	70.00	70.00	62	62	292	292	
			274A00	50.0	60.1	70.9	80	79	278	278	78.6	80	86	80	290	290	82	80.00	80.00	82	280	280	82	280	280	80.00	80.00	82	280	280	80.00	80.00	89	89	292	292	
			275A00	75.0	90.2	101.0	110	114	278	278	108.7	125	121	125	290	290	116	110	110	116	282	282	116	282	282	125	125	116	282	282	125	125	123	123	292	292	
575-3-60	STD	NONE	-	-	36.1	45	38	204	204	43	50	50	212	212	40	45.00	45.00	40	206	206	40	206	206	50.00	50.00	40	206	206	50.00	50.00	45	45	214	214			
		276A00	24.8	23.9	37.6	45	38	204	204	43.6	50	43	50	212	212	39.8	45.00	45.00	40	206	206	40	206	206	50.00	50.00	40	206	206	50.00	50.00	45	45	214	214		
		277A00	49.6	47.7	67.4	70	62	204	204	73.4	80	68	80	212	212	69.5	70.00	70.00	64	206	206	64	206	206	80.00	80.00	64	206	206	80.00	80.00	69	69	214	214		
		278A00	74.4	71.6	79.4	90	89	204	204	85.4	90	95	90	212	212	81.5	90	90	91	206	206	91	206	206	90	90	91	206	206	90	90	97	97	214	214		
		NONE	-	-	37.5	45	40	202	202	42.3	50	45	50	210	210	39.2	50.00	50.00	42	204	204	42	204	204	50.00	50.00	42	204	204	50.00	50.00	47	47	212	212		
		276A00	24.8	23.9	39.4	45	40	202	202	45.4	50	45	50	210	210	41.5	50.00	50.00	42	204	204	42	204	204	50.00	50.00	42	204	204	50.00	50.00	47	47	212	212		
		277A00	49.6	47.7	69.1	70	64	202	202	75.1	80	69	80	210	210	71.3	80.00	80.00	66	204	204	66	204	204	80.00	80.00	66	204	204	80.00	80.00	71	71	212	212		
		278A00	74.4	71.6	81.1	90	91	202	202	87.1	90	97	90	210	210	83.2	90	90	93	204	204	93	204	204	90	90	93	204	204	90	90	99	99	212	212		
HIGH	HIGH	NONE	-	-	39.4	50	42	229	229	44.2	50	50	237	237	41.1	50.00	50.00	44	231	231	44	231	231	50.00	50.00	44	231	231	50.00	50.00	49	49	239	239			
		276A00	24.8	23.9	41.8	50	42	229	229	47.8	50	50	237	237	43.9	50.00	50.00	44	231	231	44	231	231	50.00	50.00	44	231	231	50.00	50.00	49	49	239	239			
		277A00	49.6	47.7	71.5	80	66	229	229	77.5	80	71	80	237	237	73.6	80.00	80.00	68	231	231	68	231	231	80.00	80.00	68	231	231	80.00	80.00	73	73	239	239		
		278A00	74.4	71.6	83.5	90	93	229	229	89.5	100	99	100	237	237	85.6	90	90	95	231	231	95	231	231	100	100	95	231	231	100	100	101	101	239	239		

See: "Legend and Notes" on page 38

# ELECTRICAL INFORMATION

**Table 26 - UNIT WIRE/FUSE OR HACR BREAKER SIZING DATA WITH FACTORY INSTALLED 2 SPEED INDOOR FAN OPTION (cont.)**

UNIT	IFM TYPE	ELEC. HTR				NO C.O. or UNPWR C.O.										w/ PWRD C.O.									
		CRHEATER*****	Nom (kW)	FLA	MCA	NO PE.		w/ R.E. (pwrd fr/unit)		NO PE.		w/ PWRD C.O.		NO PE.		w/ PWRD C.O.		NO PE.		w/ PWRD C.O.					
						MAX FUSE or HACR BRKR	DISC. SIZE	FLA	LRA	MCA	MAX FUSE or HACR BRKR	DISC. SIZE	FLA	LRA	MCA	MAX FUSE or HACR BRKR	DISC. SIZE	FLA	LRA	MCA	MAX FUSE or HACR BRKR	DISC. SIZE	FLA	LRA	
208/230-3-60	STD	NONE	-	-	116.0/115.1	150/150	120/119	590	133/132	610	127.8/126.9	175/175	133/132	610	120.8/119.9	150/150	125/124	595	125/124	595	132.6/131.7	175/175	139/138	615	
		270A00	18.8/25.0	52.1/60.1	116.0/115.1	150/150	120/119	590/590	133/132	610/610	127.8/126.9	175/175	133/132	610/610	120.8/119.9	150/150	125/124	595/595	125/124	595/595	132.6/131.7	175/175	139/138	615/615	
		271A00	37.6/50.0	104.2/120.3	147.3/136.2	150/150	135/153	590/590	149/167	610/610	162.0/150.9	175/175	149/167	610/610	153.3/142.2	175/175	141/158	595/595	141/158	595/595	168.0/156.9	175/175	155/172	615/615	
		272A00	56.3/75.0	156.4/180.4	173.4/196.3	200/225	196/222	590/590	209/236	610/610	188.2/211.0	200/225	209/236	610/610	179.4/202.3	200/225	201/228	595/595	201/228	595/595	194.2/217.0	200/250	219/241	615/615	
		NONE	-	-	119.5	150	124	586	137	606	131.3	175	137	606	124.3	150/200	129	591	129	591	136.1	175/200	143	611	
	270A00	18.8/25.0	52.1/60.1	119.5/119.5	150/150	124/124	586/586	137/137	606/606	131.3/131.3	175/175	137/137	606/606	124.3/124.3	150/150	129/129	591/591	129/129	591/591	136.1/136.1	175/175	143/143	611/611		
	271A00	37.6/50.0	104.2/120.3	151.6/141.7	175/175	139/158	586/586	153/172	606/606	166.4/156.4	175/175	153/172	606/606	157.6/147.7	175/175	145/164	591/591	145/164	591/591	172.4/162.4	175/175	159/177	611/611		
	272A00	56.3/75.0	156.4/180.4	177.8/201.8	200/225	200/227	586/586	213/241	606/606	192.5/216.5	200/250	213/241	606/606	183.8/207.8	200/225	205/233	591/591	205/233	591/591	198.5/222.5	200/250	219/246	611/611		
	270A00	18.8/25.0	52.1/60.1	130.9	175	137	665	150	685	142.7	175	150	685	135.7	175/200	142	670	142	670	147.5	175/200	156	690		
	271A00	37.6/50.0	104.2/120.3	165.9/155.9	175/175	137/137	665/665	150/150	685/685	142.7/142.7	175/175	150/150	685/685	135.7/135.7	175/175	142/142	670/670	142/142	670/670	147.5/147.5	175/175	156/156	690/690		
460-3-60	STD	NONE	-	-	53.0	60	56	306	63	318	59.2	70	63	318	55.2	60/100	58	308	58	308	61.4	70/100	65	320	
		273A00	25.0	30.1	53.0	60	56	306	63	318	59.2	70	63	318	55.2	60/100	58	308	58	308	61.4	70/100	65	320	
		274A00	50.0	60.1	68.1	80	76	306	84	318	75.9	80	84	318	70.9	80/100	79	308	79	308	78.6	80/100	86	320	
		275A00	75.0	90.2	98.2	100	111	306	118	318	106.0	125	118	318	101.0	110	114	308	114	308	108.7	125	121	320	
		NONE	-	-	55.2	60	58	304	65	316	61.4	70	65	316	57.4	70/100	61	306	61	306	63.6	80/100	68	318	
	273A00	25.0	30.1	55.2	60	58	304	65	316	61.4	70	65	316	57.4	70/100	61	306	61	306	63.6	80/100	68	318		
	274A00	50.0	60.1	70.9	80	79	304	86	316	78.6	80	86	316	73.6	80/100	82	306	82	306	81.4	90/100	89	318		
	275A00	75.0	90.2	101.0	110	114	304	121	316	108.7	125	121	316	103.7	125	116	306	116	306	111.5	125	123	318		
	270A00	18.8/25.0	52.1/60.1	60.9	70	65	344	72	356	67.1	80	72	356	63.1	80/100	67	346	67	346	69.3	80/100	74	358		
	273A00	25.0	30.1	60.9	70	65	344	72	356	67.1	80	72	356	63.1	80/100	67	346	67	346	69.3	80/100	74	358		
274A00	50.0	60.1	78.0	90	86	344	93	356	85.7	90	93	356	80.7	90/100	88	346	88	346	88.5	100/100	95	358			
275A00	75.0	90.2	108.1	125	120	344	127	356	115.8	125	127	356	110.8	125	123	346	123	346	118.6	125	130	358			
575-3-60	STD	NONE	-	-	41.0	50	43	228	48	236	45.8	60	48	236	42.7	50/100	45	230	45	230	47.5	60/100	50	238	
		276A00	24.8	23.9	41.0	50	43	228	48	236	45.8	60	48	236	42.7	50/100	45	230	45	230	47.5	60/100	50	238	
		277A00	49.6	47.7	67.4	70	62	228	68	236	73.4	80	68	236	69.5	70/100	64	230	64	230	75.5	80/100	69	238	
		278A00	74.4	71.6	79.4	90	89	228	95	236	85.4	90	95	236	81.5	90	91	230	91	230	87.5	90	97	238	
		NONE	-	-	42.4	50	45	226	50	234	47.2	60	50	234	44.1	50/100	46	228	46	228	48.9	60/100	52	236	
	276A00	24.8	23.9	42.4	50	45	226	50	234	47.2	60	50	234	44.1	50/100	46	228	46	228	48.9	60/100	52	236		
	277A00	49.6	47.7	69.1	70	64	226	69	234	71.3	80	69	234	71.3	80/100	66	228	66	228	77.3	80/100	71	236		
	278A00	74.4	71.6	81.1	90	91	226	97	234	87.1	90	97	234	83.2	90	93	228	93	228	89.2	90	99	236		
	270A00	18.8/25.0	52.1/60.1	44.3	50	47	253	52	261	49.1	60	52	261	46.0	60/100	49	255	49	255	50.8	60/100	54	263		
	276A00	24.8	23.9	44.3	50	47	253	52	261	49.1	60	52	261	46.0	60/100	49	255	49	255	50.8	60/100	54	263		
277A00	49.6	47.7	71.5	80	66	253	71	261	73.6	80	71	261	73.6	80/100	68	255	68	255	79.6	80/100	73	263			
278A00	74.4	71.6	83.5	90	93	253	99	261	89.5	100	99	261	85.6	90	95	255	95	255	91.6	100	101	263			

See: "Legend and Notes" on page 38



# SEQUENCE OF OPERATION

## General

The sequence below describes the sequence of operation for an electro-mechanical unit with and without a factory installed EconoMiSer™ IV and X (called “economizer” in this sequence). For information regarding a direct digital controller, see the start-up, operations, and troubleshooting manual for the applicable controller.

### Electro-mechanical units with no economizer

#### Cooling (Single speed indoor fan motor) —

When the thermostat calls for cooling, terminals G and Y1 are energized. As a result, the indoor-fan contactor (IFC) and the compressor contactor (C1) are energized, causing the indoor-fan motor (IFM), compressor #1, and outdoor fan to start. If the unit has 2 stages of cooling, the thermostat will additionally energize Y2. The Y2 signal will energize compressor contactor #2 (C2), causing compressor #2 to start. Regardless of the number of stages, the outdoor-fan motor runs continuously while unit is cooling.

#### Cooling (2-speed indoor fan motor) —

Per ASHRAE 90.1 2010 standard section 6.4.3.10.b, during the first stage of cooling operation the VFD will adjust the fan motor to provide 2/3rd of the total cfm established for the unit. When a call for the second stage of cooling is required, the VFD will allow the total cfm for the unit established (100%).

#### Heating —

**NOTE:** The 558J is sold as cooling only. If electric heaters are required, use only factory-approved electric heaters. They will operate as described below.

Units have either 1 or 2 stages of electric heat. When the thermostat calls for heating, power is applied to the W1 terminal at the unit. The unit control will energize the indoor fan contactor and the first stage of electric heat. On units with two-stage heating, when additional heating is required, the second stage of electric heat (if equipped) will be energized when power is applied at the W2 terminal on the unit.

### Electro-mechanical units with an economizer

#### Cooling —

When free cooling is not available, the compressors will be controlled by the zone thermostat. When free cooling is available, the outdoor-air damper is modulated by the EconoMiSer IV and X control to provide a 50°F (10°C) to 55°F (13°C) mixed-air temperature into the zone. As the mixed air temperature fluctuates above 55°F (13°C) or below 50°F (10°C) dampers will be modulated (open or close) to bring the mixed-air temperature back within control. If mechanical cooling is utilized with free cooling, the outdoor-air damper will maintain its current position at

the time the compressor is started. If the increase in cooling capacity causes the mixed-air temperature to drop below 45°F (9°C), then the outdoor-air damper position will be decreased to the minimum position. If the mixed-air temperature continues to fall, the outdoor-air damper will close. Control returns to normal once the mixed-air temperature rises above 48°F (9°C). The power exhaust fans will be energized and de-energized, if installed, as the outdoor-air damper opens and closes.

If field-installed accessory CO<sub>2</sub> sensors are connected to the EconoMiSer IV and X control, a demand controlled ventilation strategy will begin to operate. As the CO<sub>2</sub> level in the zone increases above the CO<sub>2</sub> setpoint, the minimum position of the damper will be increased proportionally. As the CO<sub>2</sub> level decreases because of the increase in fresh air, the outdoor-air damper will be proportionally closed. For EconoMiSer IV and X operation, there must be a thermostat call for the fan (G). If the unit is occupied and the fan is on, the damper will operate at minimum position. Otherwise, the damper will be closed.

When the EconoMiSer IV and X control is in the occupied mode and a call for cooling exists (Y1 on the thermostat), the control will first check for indoor fan operation. If the fan is not on, then cooling will not be activated. If the fan is on, then the control will open the EconoMiSer IV and X damper to the minimum position.

On the initial power to the EconoMiSer IV and X control, it will take the damper up to 2 1/2 minutes before it begins to position itself. After the initial power-up, further changes in damper position can take up to 30 seconds to initiate. Damper movement from full closed to full open (or vice versa) will take between 1 1/2 and 2 1/2 minutes. If free cooling can be used as determined from the appropriate changeover command (switch, dry bulb, enthalpy curve, differential dry bulb, or differential enthalpy), then the control will modulate the dampers open to maintain the mixed-air temperature setpoint at 50°F (10°C) to 55°F (13°C). If there is a further demand for cooling (cooling second stage - Y2 is energized), then the control will bring on compressor stage 1 to maintain the mixed-air temperature setpoint. The EconoMiSer IV and X damper will be open at maximum position. EconoMiSer IV and X operation is limited to a single compressor.

**2-Speed Note:** When operating in ventilation mode only, the indoor fan motor will automatically adjust to 2/3rd of the total cfm established.

#### Heating —

The sequence of operation for the heating is the same as an electromechanical unit with no economizer. The only difference is how the economizer acts. The economizer will stay at the Economizer Minimum Position while the evaporator fan is operating. The outdoor-air damper is closed when the indoor fan is not operating.

Refer to Service and Maintenance Manual for further details.

## SEQUENCE OF OPERATION (cont.)

### Optional Perfect Humidity System

Units with the factory equipped Perfect Humidity option are capable of providing multiple modes of improved dehumidification as a variation of the normal cooling cycle. The Perfect Humidity option includes additional valves in the liquid line and discharge line of each refrigerant circuit, a small reheat condenser coil downstream of the evaporator, and Motormaster variable-speed control of some or all outdoor fans. Operation of the revised refrigerant circuit for each mode is described below.

The Perfect Humidity system provides three sub-modes of operation: Cool, Reheat1, and Reheat2.

**Cool mode** - provides a normal ratio of Sensible and Latent Cooling effect from the evaporator coil.

**Reheat1** - provides increased Latent Cooling while slightly reducing the Sensible Cooling effect.

**Reheat2** - provides normal Latent Cooling but with null or minimum Sensible Cooling effect delivered to the space.

The Reheat1 and Reheat2 modes are available when the unit is not in a Heating mode and when the Low Ambient Lockout switch is closed.

Climaproyectos  
.com



## SEQUENCE OF OPERATION (cont.)

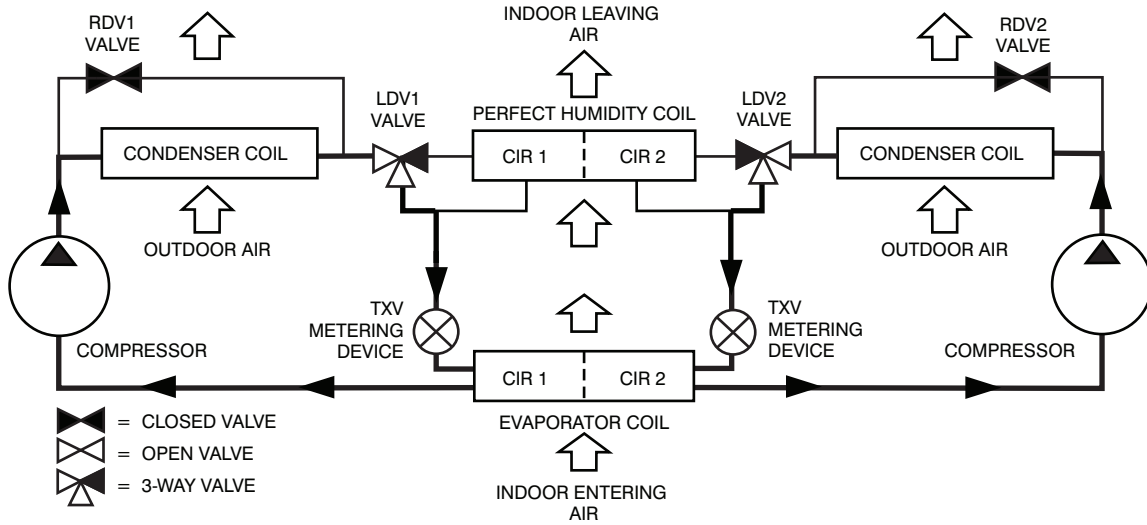

C13851

**Normal Cooling Mode - Perfect Humidity System**

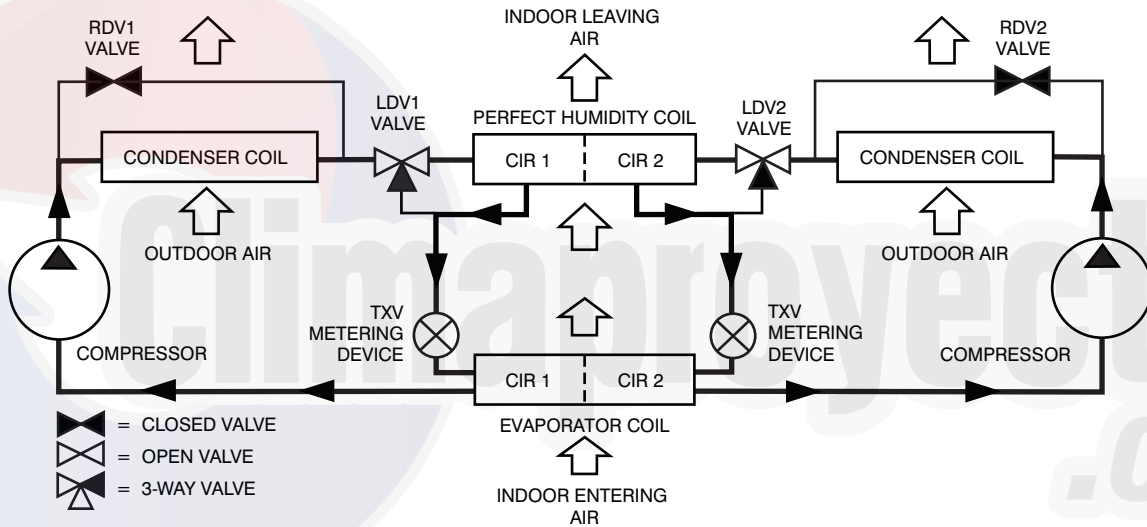

C13852

**Subcooling Mode (Reheat 1) - Perfect Humidity System**

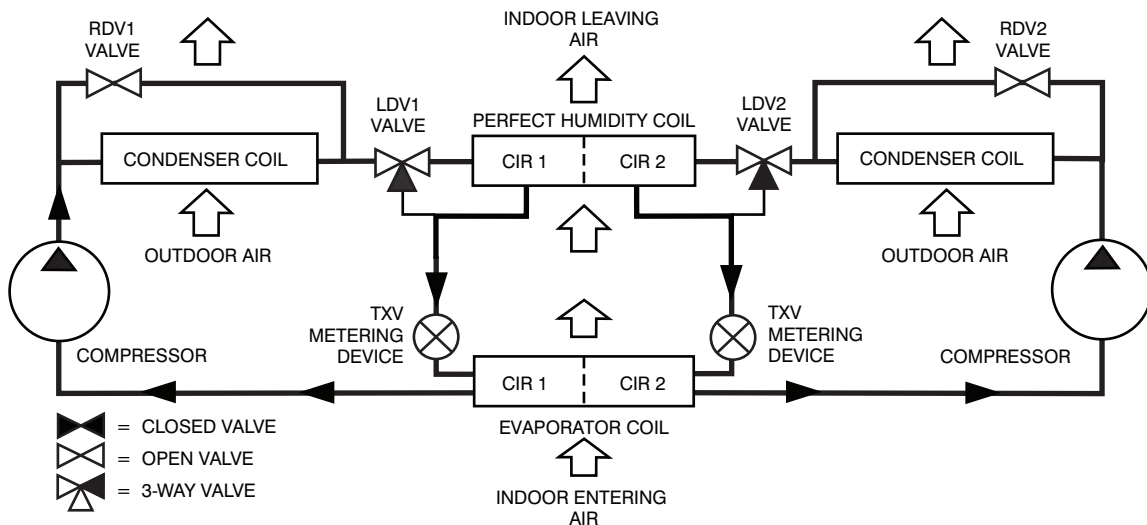

C13853

**Hot Gas Reheat Mode (Reheat 2) - Perfect Humidity System**

# GUIDE SPECIFICATIONS - 558J 18-29

Note about this specification:

These specifications are written in “Masterformat” as published by the Construction Specification Institute. Please feel free to copy this specification directly into your building spec.

## Cooling Only/Electric Heat Packaged Rooftop

### HVAC Guide Specifications

**Size Range:** 15 to 25 Nominal Tons



<u>Section</u>	<u>Description</u>
----------------	--------------------

<b>23 06 80</b>	<b>Schedules for Decentralized HVAC Equipment</b>
-----------------	---

- |                |   |
|----------------|---|
| 23 06 80.13    | Decentralized Unitary HVAC Equipment Schedule           |
| 23 06 80.13.A. | Rooftop unit schedule                                   |
| 1.             | Schedule is per the project specification requirements. |

<b>23 07 16</b>	<b>HVAC Equipment Insulation</b>
-----------------	----------------------------------

- |                |   |
|----------------|---|
| 23 07 16.13    | Decentralized, Rooftop Units:   |
| 23 07 16.13.A. | Evaporator fan compartment:   |
| 1.             | Interior cabinet surfaces shall be insulated with a minimum 1/2-in. thick, minimum 1 1/2 lb density, flexible fiberglass insulation bonded with a phenolic binder, neoprene coated on the air side. |
| 2.             | Insulation and adhesive shall meet NFPA 90A requirements for flame spread and smoke generation.   |
| 23 07 16.13.B. | Electric heat compartment:  |
| 1.             | Aluminum foil-faced fiberglass insulation shall be used.  |
| 2.             | Insulation and adhesive shall meet NFPA 90A requirements for flame spread and smoke generation.   |

<b>23 09 13</b>	<b>Instrumentation and Control Devices for HVAC</b>
-----------------	---

- |                |   |
|----------------|---|
| 23 09 13.23    | Sensors and Transmitters  |
| 23 09 13.23.A. | Thermostats   |
| 1.             | Thermostat must   |
| a.             | energize both “W” and “G” when calling for heat.  |
| b.             | have capability to energize 2 different stages of cooling, and 2 different stages of heating. |
| c.             | include capability for occupancy scheduling.  |

<b>23 09 23</b>	<b>Direct-digital Control system for HVAC</b>
-----------------	---

- |                |  |
|----------------|--|
| 23 09 23.13    | Decentralized, Rooftop Units:  |
| 23 09 23.13.A. | N/A  |
| 23 09 23.13.B. | RTU Open protocol, direct digital controller:  |
| 1.             | Shall be ASHRAE 62-2001 compliant.   |
| 2.             | Shall accept 18-30VAC, 50-60Hz, and consumer 15VA or less power.   |
| 3.             | Shall have an operating temperature range from -40°F (-40°C) to 130°F (54°C), 10% - 90% RH (non-condensing).   |
| 4.             | Shall include built-in protocol for BACNET (MS/TP and PTP modes), Modbus (RTU and ASCII), Johnson N2 and LonWorks. LonWorks Echelon processor required for all Lon applications shall be contained in separate communication board.                        |
| 5.             | Shall allow access of up to 62 network variables (SNVT). Shall be compatible with all open controllers   |
| 6.             | Baud rate Controller shall be selectable using a dipswitch.  |
| 7.             | Shall have an LED display independently showing the status of serial communication, running, errors, power, all digital outputs, and all analog inputs.  |
| 8.             | Shall accept the following inputs: space temperature, setpoint adjustment, outdoor air temperature, indoor air quality, outdoor air quality, compressor lock-out, fire shutdown, enthalpy switch, and fan status/filter status/humidity/ remote occupancy. |

9. Shall provide the following outputs: economizer, fan, cooling stage 1, cooling stage 2, heat stage 1, heat stage 2, heat stage 3/ exhaust/ reversing valve.
10. Shall have built-in surge protection circuitry through solid state polyswitches. Polyswitches shall be used on incoming power and network connections. Polyswitches will return to normal when the "trip" condition clears.
11. Shall have a battery back-up capable of a minimum of 10,000 hours of data and time clock retention during power outages.
12. Shall have built-in support for Bryant technician tool.
13. Shall include an EIA-485 protocol communication port, an access port for connection of either a computer or a Bryant technician tool, an EIA-485 port for network communication to intelligent space sensors and displays, and a port to connect an optional LonWorks communications card.
14. Software upgrades will be accomplished by either local or remote download. No software upgrades through chip replacements are allowed.

### **23 09 33 Electric and Electronic Control System for HVAC**

23 09 33.13 Decentralized, Rooftop Units:

23 09 33.13.A. General:

1. Shall be complete with self-contained low-voltage control circuit protected by a resettable circuit breaker on the 24-v transformer side. Transformer shall have 75VA capability.
2. Shall utilize color-coded wiring.
3. Shall include a central control terminal board to conveniently and safely provide connection points for vital control functions such as: smoke detectors, phase monitor, economizer, thermostat, DDC control options, and low and high pressure switches.
4. Unit shall include a minimum of one 8-pin screw terminal connection board for connection of control wiring.

23 09 33.23.B. Safeties:

1. Compressor over-temperature, over current.
2. Low-pressure switch.
  - a. Units shall have different sized connectors for the circuit 1 and circuit 2 low and high pressure switches. They shall physically prevent the cross-wiring of the safety switches between circuits 1 and 2.
  - b. Low pressure switch shall use different color wire than the high pressure switch. The purpose is to assist the installer and service technician to correctly wire and or troubleshoot the rooftop unit.
3. High-pressure switch.
  - a. Units compressors shall have different sized connectors for the circuit 1 and circuit 2 low and high pressure switches. They shall physically prevent the cross-wiring of the safety switches between circuits 1 and 2.
  - b. High pressure switch shall use different color wire than the low pressure switch. The purpose is to assist the installer and service technician to correctly wire and or troubleshoot the rooftop unit.
4. Automatic reset, motor thermal overload protector.

### **23 09 93 Sequence of Operations for HVAC Controls**

23 09 93.13 Decentralized, Rooftop Units:

23 09 93.13 INSERT SEQUENCE OF OPERATION

### **23 40 13 Panel Air Filters**

23 40 13.13 Decentralized, Rooftop Units:

23 40 13.13.A. Standard filter section

1. Shall consist of factory-installed, low velocity, throwaway 2-in. thick fiberglass filters of commercially available sizes.
2. Unit shall use only one filter size. Multiple sizes are not acceptable.
3. Filters shall be accessible through a dedicated, weather tight panel.
4. 4-in filter capabilities shall be capable with pre-engineered and approved Bryant filter track field installed accessory. This kit requires field furnished filters.

### **23 81 19 Self-Contained Air Conditioners**

23 81 19.13 Medium-Capacity Self-Contained Air Conditioners (558J\*18-29)

23 81 19.13.A. General

1. Outdoor, rooftop mounted, electrically controlled, heating and cooling unit utilizing hermetic scroll compressor(s) for cooling duty and with optional electrical heating accessories for heating duty.
2. Factory assembled, single-piece heating and cooling rooftop unit. Contained within the unit enclosure shall be all factory wiring, piping, controls, and special features required prior to field start-up.

3. Unit shall use environmentally safe, Puron refrigerant.
4. Unit shall be installed in accordance with the manufacturer's instructions.
5. Unit must be selected and installed in compliance with local, state, and federal codes.

23 81 19.13.B. Quality Assurance

1. Unit meets ASHRAE 90.1 minimum efficiency requirements.
2. Unit shall be rated in accordance with AHRI Standard 340/360.
3. Unit shall be designed to conform to ASHRAE 15.
4. Unit shall be ETL-tested and certified in accordance with ANSI Z21.47 Standards and ETL-listed and certified under Canadian standards as a total package for safety requirements.
5. Insulation and adhesive shall meet NFPA 90A requirements for flame spread and smoke generation.
6. Unit casing shall be capable of withstanding 500-hour salt spray exposure per ASTM B117 (scribed specimen).
7. Unit casing shall be capable of withstanding Federal Test Method Standard No. 141 (Method 6061) 5000-hour salt spray.
8. Unit shall be designed and manufactured in accordance with ISO 9001.
9. Roof curb shall be designed to conform to NRCA Standards.
10. Unit shall be subjected to a completely automated run test on the assembly line. The data for each unit will be stored at the factory, and must be available upon request.
11. Unit shall be designed in accordance with UL Standard 1995, including tested to withstand rain.
12. Unit shall be constructed to prevent intrusion of snow and tested to prevent snow intrusion into the control box up to 40 mph.
13. Unit shake tested to assurance level 1, ASTM D4169 to ensure shipping reliability.
14. High Efficient Motors listed shall meet section 313 of the Energy Independence and Security Act of 2007 (EISA 2007)

23 81 19.13.C. Delivery, Storage, and Handling

1. Unit shall be stored and handled per manufacturer's recommendations.
2. Lifted by crane requires either shipping top panel or spreader bars.
3. Unit shall only be stored or positioned in the upright position.

23 81 19.13.D. Project Conditions

1. As specified in the contract.

23 81 19.13.E. Operating Characteristics

1. Unit shall be capable of starting and running at 115°F (46°C) ambient outdoor temperature, meeting maximum load criteria of AHRI Standard 340/360 at ± 10% voltage.
2. Compressor with standard controls shall be capable of operation from 35°F (2°C) , ambient outdoor temperatures. Accessory kits are necessary if mechanically cooling at ambient temperatures below 35°F (2°C).
3. Unit shall discharge supply air horizontally as shown on contract drawings.
4. Unit shall be factory furnished for horizontal configuration. No field conversion is required.

23 81 19.13.F. Electrical Requirements

1. Main power supply voltage, phase, and frequency must match those required by the manufacturer.

23 81 19.13.G. Unit Cabinet

1. Unit cabinet shall be constructed of galvanized steel, and shall be bonderized and coated with a pre-painted baked enamel finish on all externally exposed surfaces.
2. Unit cabinet exterior paint shall be: film thickness, (dry) 0.003 inches minimum, gloss (per ASTM D523, 60°F / 16°C): 60, Hardness: H-2H Pencil hardness.
3. Evaporator fan compartment interior cabinet insulation shall conform to AHRI Standards 340/360 minimum exterior sweat criteria. Interior surfaces shall be insulated with a minimum 1/2-in. thick, 1 lb density, flexible fiberglass insulation, neoprene coated on the air side. Aluminum foil-faced fiberglass insulation shall be used in the heat compartment.
4. Base of unit shall have a minimum of four locations for factory thru-the-base electrical connections. Connections shall be internal to the cabinet to protect from environmental issues.
5. Base Rail
  - a. Unit shall have base rails on a minimum of 2 sides.
  - b. Holes shall be provided in the base rails for rigging shackles to facilitate maneuvering and overhead rigging.
  - c. Holes shall be provided in the base rail for moving the rooftop by fork truck.
  - d. Base rail shall be a minimum of 16 gauge thickness.

6. Condensate pan and connections:
  - a. Shall be a sloped condensate drain pan made of a non-corrosive material.
  - b. Shall comply with ASHRAE Standard 62.
  - c. Shall use a 3/4-in -14 NPT drain connection at the end of the drain pan. Connection shall be made per manufacturer's recommendations.
7. Top panel:
  - a. Shall be a multi-piece top panel linked with water tight flanges and interlocking systems.
8. Electrical Connections
  - a. All unit power wiring shall enter unit cabinet at a single, factory-prepared, knockout location.
  - b. Thru-the-base capability
    - (1.) Thru-the-base provisions/connections are available as standard with every unit. When bottom connections are required, field furnished couplings are required.
    - (2.) No basepan penetration, other than those authorized by the manufacturer, is permitted.
9. Component access panels (standard)
  - a. Cabinet panels shall be easily removable for servicing.
  - b. Unit shall have one factory installed, removable, filter access panel.
  - c. Panels covering control box and filters shall have molded composite handles while the blower access door shall have an integrated flange for easy removal.
  - d. Handles shall be UV modified, composite. They shall be permanently attached, and recessed into the panel.
  - e. Screws on the vertical portion of all removable access panel shall engage into heat resistant, molded composite collars.
  - f. Collars shall be removable and easily replaceable using manufacturer recommended parts.

23 81 19.13.H. N/A

23 81 19.13.I. Coils

1. Standard Aluminum Fin/Copper Tube Coils:
  - a. Standard evaporator and condenser coils shall have aluminum lanced plate fins mechanically bonded to seamless internally grooved copper tubes with all joints brazed.
  - b. Evaporator coils shall be leak tested to 150 psig, pressure tested to 450 psig, and qualified to UL 1995 burst test at 1775 psig.
  - c. Condenser coils shall be leak tested to 150 psig, pressure tested to 650 psig, and qualified to UL 1995 burst test at 1980 psig.
2. Optional Pre-coated aluminum-fin condenser coils:
  - a. Shall have a durable epoxy-phenolic coating to provide protection in mildly corrosive coastal environments.
  - b. Coating shall be applied to the aluminum fin stock prior to the fin stamping process to create an inert barrier between the aluminum fin and copper tube.
  - c. Epoxy-phenolic barrier shall minimize galvanic action between dissimilar metals.
3. Optional Copper-fin evaporator and condenser coils:
  - a. Shall be constructed of copper fins mechanically bonded to copper tubes and copper tube sheets.
  - b. Galvanized steel tube sheets shall not be acceptable.
  - c. A polymer strip shall prevent coil assembly from contacting the sheet metal coil pan to minimize potential for galvanic corrosion between coil and pan.
4. Optional E-coated aluminum-fin evaporator and condenser coils:
  - a. Shall have a flexible epoxy polymer coating uniformly applied to all coil surface areas without material bridging between fins.
  - b. Coating process shall ensure complete coil encapsulation of tubes, fins and headers.
  - c. Color shall be high gloss black with gloss per ASTM D523-89.
  - d. Uniform dry film thickness from 0.8 to 1.2 mil on all surface areas including fin edges.
  - e. Superior hardness characteristics of 2H per ASTM D3363-92A and cross-hatch adhesion of 4B-5B per ASTM D3359-93.
  - f. Impact resistance shall be up to 160 in.-lb (ASTM D2794-93).
  - g. Humidity and water immersion resistance shall be up to minimum 1000 and 250 hours respectively (ASTM D2247-92 and ASTM D870-92).
  - h. Corrosion durability shall be confirmed through testing to be no less than 1000 hours salt spray per ASTM B117-90.

23 81 19.13.J. Refrigerant Components

1. Refrigerant circuit shall include the following control, safety, and maintenance features:
  - a. Thermostatic Expansion Valve (TXV) shall help provide optimum performance across the entire operating range. Shall contain removable power element to allow change out of power element and bulb without removing the valve body.
  - b. Refrigerant filter drier - Solid core design.
  - c. Service gauge connections on suction and discharge lines.
  - d. Pressure gauge access through a specially designed screen on the side of the unit.
2. Compressors
  - a. Unit shall use one fully hermetic, scroll compressor for each independent refrigeration circuit.
  - b. Models shall be available with 2 compressor/2-stage cooling.
  - c. Compressor motors shall be cooled by refrigerant gas passing through motor windings.
  - d. Compressors shall be internally protected from high discharge temperature conditions.
  - e. Compressors shall be protected from an over-temperature and over-ampere conditions by an internal, motor overload device.
  - f. Compressor shall be factory mounted on rubber grommets.
  - g. Compressor motors shall have internal line break thermal, current overload and high pressure differential protection.
  - h. Crankcase heaters shall not be required for normal operating range, unless provided by the factory.

23 81 19.13.K. Filter Section

1. Filters access is specified in the unit cabinet section of this specification.
2. Filters shall be held in place by a preformed slide out filter tray, facilitating easy removal and installation.
3. Shall consist of factory-installed, low velocity, throw-away 2-in. thick fiberglass filters.
4. Filters shall be standard, commercially available sizes.
5. Only one size filter per unit is allowed.
6. 4-in filter capability is possible with a field installed pre-engineered slide out filter track accessory. 4-in filters are field furnished.

23 81 19.13.L. Evaporator Fan and Motor

1. Evaporator fan motor:
  - a. Shall have inherent automatic-reset thermal overload protection or circuit breaker.
  - b. Shall have a maximum continuous bhp rating for continuous duty operation; no safety factors above that rating shall be required.
2. Belt-driven Evaporator Fan:
  - a. Belt drive shall include an adjustable-pitch motor pulley and belt break protection system.
  - b. Shall use rigid pillow block bearing system with lubricate fittings at are accessible or lubrication line.
  - c. Blower fan shall be double-inlet type with forward-curved blades.
  - d. Shall be constructed from steel with a corrosion resistant finish and dynamically balanced.

23 81 19.13.M. Condenser Fans and Motors

1. Condenser fan motors:
  - a. Shall be a totally enclosed motor.
  - b. Shall use permanently lubricated bearings.
  - c. Shall have inherent thermal overload protection with an automatic reset feature.
  - d. Shall use a shaft-down design.
2. Condenser Fans:
  - a. Shall be a direct-driven propeller type fan.
  - b. Shall have galvalum blades riveted to corrosion-resistant steel spiders and shall be dynamically balanced.

23 81 19.13.N. Special Features, Options and Accessories

1. 2-Speed Indoor Fan Motor System for 2-stage cooling models only:
  - a. Evaporator fan motor:
    - (1.) Shall have permanently lubricated bearings.
    - (2.) Shall have a maximum continuous bhp rating for continuous duty operation; no safety factors above that rating.
    - (3.) Shall be Variable Frequency duty and 2-speed control.



- (4.) Shall contain motor shaft grounding ring to prevent electrical bearing fluting damage by safely diverting harmful shaft voltages and bearing currents to ground.
2. Variable Frequency Drive (VFD). Only available on 2-speed indoor fan motor option:
  - a. Shall be installed inside the unit cabinet, mounted, wired and tested.
  - b. Shall contain Electromagnetic Interference (EMI) frequency protection.
  - c. Insulated Gate Bi-Polar Transistors (IGBT) used to produce the output pulse width modulated (PWM) waveform, allowing for quiet motor operation.
  - d. Self diagnostics with fault and power code LED indicator. Field accessory Display Kit available for further diagnostics and special setup applications.
  - e. RS485 capability standard.
  - f. Electronic thermal overload protection.
  - g. 5% swinging chokes for harmonic reduction and improved power factor.
  - h. All printed circuit boards shall be conformal coated.
3. Standard Integrated Economizers:
  - a. Integrated, gear-driven opposing blade design type capable of simultaneous economizer and compressor operation.
  - b. Independent modules for horizontal return configuration shall be available. Shall be available as a factory installed option or field installed accessory.
  - c. Damper blades shall be galvanized steel with composite gears. Plastic or composite blades on intake or return shall not be acceptable.
  - d. Shall include all hardware and controls to provide free cooling with outdoor air when temperature and/or humidity are below setpoints.
  - e. Shall be equipped with gear driven dampers for both the outdoor ventilation air and the return air for positive air stream control.
  - f. Standard models shall be equipped with low-leakage dampers, not to exceed 2% leakage at 1 in. wg pressure differential. Economizer controller on electromechanical units shall be Honeywell W7212 that provides:
    - (1.) Combined minimum and DCV maximum damper position potentiometers with compressor staging relay.
    - (2.) Functions with solid state analog enthalpy or dry bulb changeover control sensing.
    - (3.) Contain LED indicates for:
      - when free cooling is available
      - when module is in DCV mode
      - when exhaust fan contact is closed
  - g. Ultra low leak EconoMi\$er X system shall be available on models with 2-speed indoor fan motor 2-speed Variable Frequency Drive (VFD) systems. Only available on 2-speed indoor fan motor systems with electromechanical controls or RTU Open.
    - (1.) Maximum damper leakage rate to be equal to or less than 4.0 cfm/sq. ft. at 1.0 in. w.g., meeting or exceeding ASHRAE 90.1 requirements. Economizer controller on electromechanical units shall be Honeywell W7220 that provides:
      - (2.) 2-line LCD interface screen for setup, configuration and troubleshooting
      - (3.) On-board fault detection and diagnostics
      - (4.) Sensor failure loss of communication identification
      - (5.) Automatic sensor detection
      - (6.) Capabilities for use with multiple-speed indoor fan systems
      - (7.) Utilize digital sensors: Dry bulb and Enthalpy
  - h. Shall be capable of introducing up to 100% outdoor air.
  - i. Shall be equipped with a barometric relief damper capable of relieving up to 100% return air.
  - j. Shall be designed to close damper(s) during loss-of-power situations with spring return built into motor.
  - k. Dry bulb outdoor air temperature sensor shall be provided as standard. Outdoor air sensor setpoint shall be adjustable and shall range from 40 to 100°F / 4 to 38°C. Additional sensor options shall be available as accessories.
  - l. The economizer controller shall also provide control of an accessory power exhaust unit function. Factory set at 100%, with a range of 0% to 100%.



- m. The economizer shall maintain minimum airflow into the building during occupied period and provide design ventilation rate for full occupancy. A remote potentiometer may be used to override the damper setpoint.
  - n. Dampers shall be completely closed when the unit is in the unoccupied mode.
  - o. Economizer controller shall accept a 2-10 Vdc CO<sub>2</sub> sensor input for IAQ/DCV control. In this mode, dampers shall modulate the outdoor air damper to provide ventilation based on the sensor input.
  - p. Compressor lockout sensor shall open at 35°F (2°C) and close closes at 50°F (10°C).
  - q. Actuator shall be direct coupled to economizer gear. No linkage arms or control rods shall be acceptable.
  - r. Economizer controller shall provide indications when in free cooling mode, in the DCV mode, or the exhaust fan contact is closed.
4. Two-Position Damper
- a. Damper shall be a 2-position damper. Damper travel shall be from the full closed position to the field adjustable %-open setpoint.
  - b. Damper shall include adjustable damper travel from 25% to 100% (full open).
  - c. Damper shall include single or dual blade, gear driven dampers and actuator motor.
  - d. Actuator shall be direct coupled to damper gear. No linkage arms or control rods shall be acceptable.
  - e. Damper will admit up to 100% outdoor air for applicable rooftop units.
  - f. Damper shall close upon indoor (evaporator) fan shutoff and/or loss of power.
  - g. The damper actuator shall plug into the rooftop unit's wiring harness plug. No hard wiring shall be required.
  - h. Outside air hood shall include aluminum water entrainment filter
5. Manual damper
- a. Manual damper package shall consist of damper, air inlet screen, and rain hood which can be preset to admit up to 25% outdoor air for year round ventilation.
6. Perfect Humidity System.
- a. The Perfect Humidity System shall be factory-installed and shall provide greater dehumidification of the occupied space by two modes of dehumidification operations beside its normal design cooling mode:
    - (1.) Subcooling mode further subcools the hot liquid refrigerant leaving the condenser coil when both temperature and humidity in the space are not satisfied.
    - (2.) Hot gas reheat mode shall mix a portion of the hot gas from the discharge of the compressor with the hot liquid refrigerant leaving the condenser coil to create a two-phase heat transfer in the system, resulting in a neutral leaving- air temperature when only humidity in the space is not satisfied.
    - (3.) Includes Head Pressure Controller.
7. Head Pressure Control Package (MotorMaster)
- a. Controller shall control coil head pressure by condenser-fan speed modulation or condenser-fan cycling and wind baffles.
  - b. Shall consist of solid-state control and condenser-coil temperature sensor to maintain condensing temperature between 90°F (32°C) and 110°F (43°C) at outdoor ambient temperatures down to -20°F (-29°C).
8. Condenser Coil Hail Guard Assembly
- a. Shall protect against damage from hail.
  - b. Shall be louvered style design.
9. Unit-Mounted, Non-Fused Disconnect Switch:
- a. Switch shall be factory-installed, internally mounted.
  - b. National Electric Code (NEC) and ETL approved non-fused switch shall provide unit power shutoff.
  - c. Shall be accessible from outside the unit
  - d. Shall provide local shutdown and lockout capability.
10. Convenience Outlet:
- a. Powered convenience outlet.
    - (1.) Outlet shall be powered from main line power to the rooftop unit.
    - (2.) Outlet shall be powered from line side of disconnect by installing contractor, as required by code. If outlet is powered from load side of disconnect, unit electrical ratings shall be ETL certified and rated for additional outlet amperage.
    - (3.) Outlet shall be factory-installed and internally mounted with easily accessible 115-v female receptacle.

- (4.) Outlet shall include 15 amp GFI receptacles with independent fuse protection.
    - (5.) Voltage required to operate convenience outlet shall be provided by a factory-installed step-down transformer.
    - (6.) Outlet shall be accessible from outside the unit.
    - (7.) Outlet shall include a field-installed "Wet in Use" cover.
  - b. Non-Powered convenience outlet.
    - (1.) Outlet shall be powered from a separate 115/120v power source.
    - (2.) A transformer shall not be included.
    - (3.) Outlet shall be factory-installed and internally mounted with easily accessible 115-v female receptacle.
    - (4.) Outlet shall include 15 amp GFI receptacles with independent fuse protection.
    - (5.) Outlet shall be accessible from outside the unit.
    - (6.) Outlet shall include a field-installed "Wet in Use" cover.
11. Fan/Filter Status Switch:
  - a. Switch shall provide status of indoor evaporator fan (ON/OFF) or filter (CLEAN/DIRTY).
  - b. Status shall be displayed either over communication bus (when used with direct digital controls) or with an indicator light at the thermostat.
12. Centrifugal Power Exhaust:
  - a. Power exhaust shall be used in conjunction with an integrated economizer.
  - b. Independent modules for horizontal return configurations shall be available.
  - c. Horizontal power exhaust shall be mounted in return ductwork.
  - d. Power exhaust shall be controlled by economizer controller operation. Exhaust fans shall be energized when dampers open past the 0-100% adjustable setpoint on the economizer control.
13. High-Static Indoor Fan Motor(s) and Drive(s):
  - a. High-static motor(s) and drive(s) shall be factory-installed to provide additional performance range.
14. Outdoor Air Enthalpy Sensor:
  - a. The outdoor air enthalpy sensor shall be used to provide single enthalpy control. When used in conjunction with a return air enthalpy sensor, the unit will provide differential enthalpy control. The sensor allows the unit to determine if outside air is suitable for free cooling.
15. Return Air Enthalpy Sensor:
  - a. The return air enthalpy sensor shall be used in conjunction with an outdoor air enthalpy sensor to provide differential enthalpy control.
16. Indoor Air Quality (CO<sub>2</sub>) Sensor:
  - a. Shall be able to provide demand ventilation indoor air quality (IAQ) control.
  - b. The IAQ sensor shall be available in duct mount, wall mount, or wall mount with LED display. The setpoint shall have adjustment capability.
17. Smoke detectors:
  - a. Shall be a Four-Wire Controller and Detector.
  - b. Shall be environmental compensated with differential sensing for reliable, stable, and drift-free sensitivity.
  - c. Shall use magnet-activated test/reset sensor switches.
  - d. Shall have tool-less connection terminal access.
  - e. Shall have a recessed momentary switch for testing and resetting the detector.
  - f. Controller shall include:
    - (1.) One set of normally open alarm initiation contacts for connection to an initiating device circuit on a fire alarm control panel.
    - (2.) Two Form-C auxiliary alarm relays for interface with rooftop unit or other equipment.
    - (3.) One Form-C supervision (trouble) relay to control the operation of the Trouble LED on a remote test/reset station.
    - (4.) Capable of direct connection to two individual detector modules.
    - (5.) Can be wired to up to 14 other duct smoke detectors for multiple fan shutdown applications.
18. Winter start kit
  - a. Shall contain a bypass device around the low pressure switch.
  - b. Shall be required when mechanical cooling is required down to 25°F (-4°C).
  - c. Shall not be required to operate on an economizer when below an outdoor ambient of 40°F (4°C).

19. Time Guard
  - a. Shall prevent compressor short cycling by providing a 5-minute delay ( $\pm 2$  minutes) before restarting a compressor after shutdown for any reason.
  - b. One device shall be required per compressor.
20. Electric Heat:
  - a. Heating Section
    - (1.) Heater element open coil resistance wire, nickel-chrome alloy, 0.29 inches inside diameter, strung through ceramic insulators mounted on metal frame. Coil ends are staked and welded to terminal screw slots.
    - (2.) Heater assemblies are provided with integral fusing for protection of internal heater circuits not exceeding 48 amps each. Auto reset thermo limit controls, magnetic heater contactors (24 v coil) and terminal block all mounted in electric heater control box (minimum 18 ga galvanized steel) attached to end of heater assembly.
21. Barometric Hood (Horizontal Economizer Applications)
  - a. Shall be required when a horizontal economizer and barometric relief are required. Barometric relief damper must be installed in the return air (horizontal) duct work. This hood provides weather protection.
22. Display Kit for Variable Frequency Drive
  - a. Kit allows the ability to access the VFD controller programs to provide special setup capabilities and diagnostics.
  - b. Kit contains display module and communication cable.
  - c. Display Kit can be permanently installed in the unit or used on any 2-Speed Indoor Fan Motor System VFD controller as needed.
23. Hinged Access Panels
  - a. Shall provide easy access through hinged access doors with vinyl coated door retainers.
  - b. Shall be on major panels of – filter, control box, and fan motor.



Climaproyectos  
.com

