

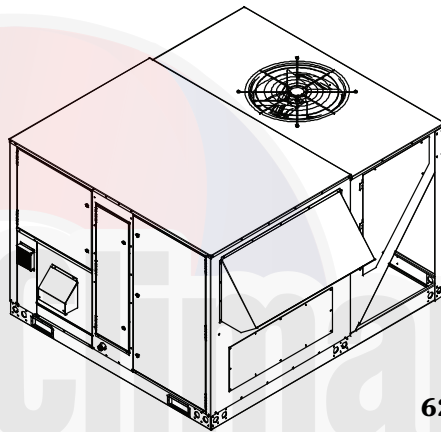

Product Data

62DA,DB,DC,DD07-38 Dedicated Vertical or Horizontal Outdoor Air Unit with Optional Energy Wheel

6 to 35 Nominal Tons



62D07-09

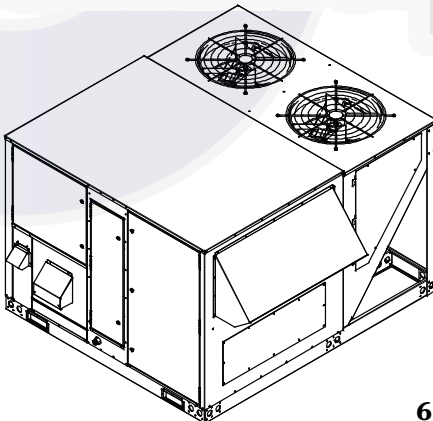

62D12-20

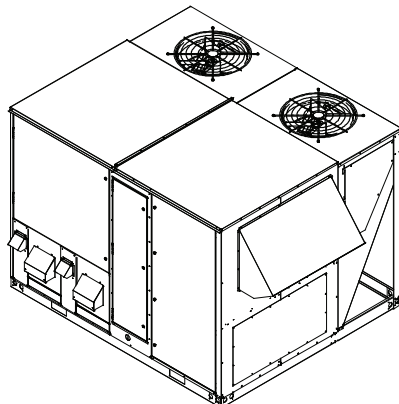

62D22-38

Carrier's 62D Series commercial dedicated outdoor air units offer:

- Capacities up to 35 nominal tons
- Vertical or horizontal configurations
- Puron® environmentally balanced refrigerant (R-410A) as standard
- Double wall construction
- Optional AHRI (Air-Conditioning, Heating, and Refrigeration Institute) listed energy recovery wheel
- Multiple heating options
- Multiple fan options
- Microprocessor control with accessory keypad and easy to view display
- Multiple reheat option
- Remote communication capability
- Digital compressor option
- 100% outdoor air operation

Features/Benefits

Carrier's 62D commercial packaged, dedicated, outdoor air unit offers efficiency, application flexibility, quality, reliability and easy maintenance.

High efficiency

The Carrier dedicated outdoor air unit utilizes highly efficient scroll compressors that have been optimally designed for use with Puron refrigerant (R-410A). Operating efficiency of the unit may be increased by adding the optional energy recovery system.

Features/Benefits (cont)



The energy recovery system uses an AHRI listed energy recovery wheel to transfer sensible and latent heat between the incoming air and the exhaust air, reducing energy consumption and improving indoor conditions.

Flexibility to suit many applications

The Carrier 62D units are designed to meet customer's requirements for new construction, replacement opportunities, and special applications. The customer can choose from vertical or horizontal supply configurations and over 6 supply fan motor horsepower ratings, with backward curved, forward curved, airfoil or backward inclined supply fans.

Supply fans may be provided with spring isolation and seismic restraints to address earthquake design requirements.

Staged or modulating heat sources are available, including gas furnace, electric insert, hot water coil or steam coil.

Also available are digital compressor, hot gas reheat, power exhaust, 2 or 4-in. filters, and rotary energy recovery wheel.

Roof curbs that follow the NRCA (National Roofing Contractors Association) guidelines are available for vertical applications in 14-in. and 24-in. heights and are installed and weather-proofed by the roofing contractor. Units with horizontal connections may be either curb or slab mounted.

All 62DA and DB units bring in 100% outdoor air through the outdoor air intake hood and do not have a return air connection. The 62DA units have a vertical supply duct opening in the bottom of the unit. The 62DB units have a horizontal supply duct opening in the side of the unit.

All 62DC and DD units bring in 100% outdoor air through the outdoor air intake hood. They may also be equipped with factory-installed power exhaust and/or an energy conservation wheel. The return air to these units is not re-circulated or mixed with the incoming outdoor air. The return air may be used to transfer energy to the incoming air via the energy conservation wheel and is then exhausted. The 62DC units have a vertical supply

and return duct opening in the bottom of the unit. The 62DD units have a horizontal supply duct opening in the side of the unit and a vertical return opening in the bottom of the unit.

Durable construction

Cabinets are constructed of heavy gage galvanized steel with a pre-painted exterior finish to protect the cabinet and preserve the appearance through a long operating life.

The cabinet features a double wall design with a galvanized inner liner. The double wall design is insulated with closed-cell foam which adds rigidity to the structure and resists moisture intrusion.

Quality and reliability

All units are run tested prior to leaving the factory to help ensure proper operation and enhance life expectancy of key components. Components undergo numerous checks and inspections throughout the manufacturing process to eliminate components that do not meet Carrier's high quality standards.

Reliable, hermetic scroll compressors, equipped with crankcase heaters, are mounted on rubber isolation mounts for smooth, quiet operation.

Mechanically and electrically independent dual refrigeration circuits (size 12 and larger) provide redundancy in the event that one circuit should require service. All refrigerant circuits utilize a thermostatic expansion valve (TXV) to ensure proper refrigerant metering throughout the unit's broad operating envelope. The refrigeration

circuits are protected by filter driers specifically designed for Puron® refrigerant (R-410A).

Standard warranty coverage provides a one-year parts warranty and 5 years on the stainless steel gas heat exchanger.

Easy to install, maintain and service

Maintaining and servicing a dedicated outdoor air unit is critical in maximizing the life expectancy and efficient operation of the unit. The Carrier unit has been designed for easy access with simple maintenance procedures.

Hinged access panels provide easy access to controls, fans, coils and filters. Slide-out supply fan system allows easy maintenance of belts, bearings, blower wheels and motors.

A dedicated vertical or horizontal design does not require conversion time during the unit installation. Through the curb power connection minimizes roof penetrations.

Power connections are in a protected area, away from harsh environmental conditions. All units feature heavy gage formed galvanized steel base rails with rigging openings to simplify handling and lifting at the job site.

Indoor air quality

The Carrier dedicated outdoor air unit offers 2 and 4-in. filter tracks that accept a variety of filter types and filter MERV ratings.

The condensate drain pan is double sloped to eliminate standing water per ASHRAE (American Society of

Table of contents

	Page
Features/Benefits	1-3
Model Number Nomenclature	4,5
Ratings and Capacities	6,7
Physical Data	8-12
Options and Accessories	13
Base Unit Dimensions	14-22
Accessory Dimensions	23
Selection Procedure	23
Performance Data	24-47
Electrical Data	48
Controls	49-51
Typical Wiring Schematics	52-67
Guide Specifications	68-72

Heating, Refrigerating, and Air-Conditioning Engineers) Standard 62-1089R. The drain pan is fabricated of heavy gage stainless steel to resist corrosion and is insulated on the bottom with closed cell insulation.

The double wall design of the unit with galvanized interior liners allows easy cleaning of the interior surfaces.

Energy recovery

The Carrier dedicated outdoor air unit may be optionally equipped with an energy recovery (enthalpy) wheel. The enthalpy wheel meets the requirements of AHRI standard 1060 and is certified by AHRI. This energy recovery wheel is sized to provide increased energy recovery and humidity control based on the application requirements. The energy wheel is mounted in a slide-out cassette for simplified maintenance.

Heating systems

Carrier dedicated outdoor air units may be equipped with a variety of heat system types: gas heat (natural gas or liquefied petroleum gas), electric, steam, or hot water. Precise leaving air temperature control is provided via staged

or modulating heat control systems.

The gas heating systems are of the induced-draft design that draws hot combustion gases through the heat exchanger at the ideal rate for maximum heat transfer. Induced-draft systems are an inherently safer design than forced draft, positive pressure designs.

Induced-draft designs operate the heat exchanger under negative pressure, helping to prevent leakage of flue gases into the supply airstream. The gas heat system utilizes a direct-spark ignition and is protected by numerous safety circuits.

Microprocessor control

The microprocessor-based controller provides complete system control of unit operation. The controller monitors all system sensors and makes operating decisions based upon the user's configuration inputs.

Local access to the microprocessor control may be accomplished via the accessory BACview handheld keypad/display unit. The BACview handheld keypad/display features a numeric keypad, direction keys, four

programmable function keys, and a backlit LCD (liquid crystal diode) display. The display is a large 4-line by 40-character display that is easy to read, even in low light conditions. Access to the microprocessor may also be accomplished via a PC using Carrier software.

In addition, the microprocessor control has the following features:

- simple access to set points, time schedules, status values, and unit configuration parameters
- supports communications with BACnet*, Modbus†, and optionally with LonWorks** building automation protocols
- alarm conditions are indicated via an alarm LED and an audible signal
- alarm history is recorded and may be accessed via the BACview handheld keypad/display
- password protection
- compressor minimum off time (5 minutes) feature
- service test and a service diagnostic mode

* Sponsored by ASHRAE (American Society of Heating, Refrigerating, and Air-Conditioning Engineers).

† Registered trademark of Schneider Electric.

** Registered trademark of Echelon Corporation.

Model number nomenclature



62 DA F 0 34 - E 4 6 3 1 - C CA

62 - Dedicated Outdoor Air Unit

Configuration

- DA - 100% OA Vertical Supply / No Return
- DB - 100% OA Horizontal Supply / No Return
- DC - 100% OA Vertical Supply / Vertical Return
- DD - 100% OA Horizontal Supply / Vertical Return

Heat Options*

-	-	None	G	-	400,000 Btuh	3	-	15 / 20 kW
A	-	75,000 Btuh			Gas Heat			Elect Heat
		Gas Heat	H	-	500,000 Btuh	4	-	18.8 / 25 kW
B	-	100,000 Btuh			Gas Heat			Elect Heat
		Gas Heat	J	-	600,000 Btuh	5	-	22.6 / 30 kW
C	-	150,000 Btuh			Gas Heat			Elect Heat
		Gas Heat	W	-	Hot Water	6	-	26.3 / 35 kW
D	-	200,000 Btuh			Heating Coil†			Elect Heat
		Gas Heat	Y	-	Steam	7	-	30 / 40 kW
E	-	250,000 Btuh			Heating Coil†			Elect Heat
		Gas Heat	1	-	7.5 / 10 kW	8	-	35.7 / 50 kW
F	-	300,000 Btuh			Elect Heat			Elect Heat
		Gas Heat	2	-	11.3 / 15 kW	9	-	45 / 60 kW
					Elect Heat			Elect Heat

Energy Conservation Wheel (ECW) Options **

0	-	None	J	-	ECW (36 in.) with VFD TD
A	-	ECW (36 in.)	K	-	ECW (42 in.) with VFD TD
B	-	ECW (42 in.)	L	-	ECW (48 in.) with VFD TD
C	-	ECW (48 in.)	M	-	ECW (54 in.) with VFD TD
D	-	ECW (54 in.)	N	-	ECW (36 in.) with Byp and VFD TD
E	-	ECW (36 in.) with Byp	P	-	ECW (42 in.) with Byp and VFD TD
F	-	ECW (42 in.) with Byp	Q	-	ECW (48 in.) with Byp and VFD TD
G	-	ECW (48 in.) with Byp	R	-	ECW (54 in.) with Byp and VFD TD
H	-	ECW (54 in.) with Byp			

Unit Size - Nominal Tons

07 - 6	14 - 12	20 - 18	30 - 27
08 - 7	15 - 14	22 - 19	34 - 30
09 - 8	16 - 15	24 - 20	38 - 35
12 - 10			

**SEE NEXT PAGE
FOR REMAINDER
OF MODEL NUMBER
NOMENCLATURE**

Supply Fan Motor Options

A	-	1/2 HP	H	-	7 1/2 HP	R	-	3 HP with VFD
B	-	3/4 HP	J	-	10 HP	S	-	5 HP with VFD
C	-	1 HP	K	-	15 HP	T	-	7 1/2 HP with VFD
D	-	1 1/2 HP	L	-	20 HP	V	-	10 HP with VFD
E	-	2 HP	N	-	1 HP with VFD	W	-	15 HP with VFD
F	-	3 HP	P	-	1 1/2 HP with VFD	X	-	20 HP with VFD
G	-	5 HP	Q	-	2 HP with VFD			

Control Options

- - None
- A - Filter Status Switch
- C - Firestat
- D - RA Smoke Detector
- G - Filter Status Switch and Firestat
- H - Filter Status Switch and RA Smoke Detector
- N - Firestat and RA Smoke Detector
- V - Filter Status Switch and Firestat and RA Smoke Detector

62 DA F 0 34 - E 4 6 3 1 - C CA

**SEE PREVIOUS PAGE
FOR REMAINDER
OF MODEL NUMBER
NOMENCLATURE**

Coil Options

- D - Al/Cu Cond, Al/Cu 4-Row Evap, no HGRH, with Cycling Cond Fan
- E - Al/Cu Cond, Al/Cu 4-Row Evap, no HGRH, with Vari-Speed Cond Fan
- H - Al/Cu Cond, Al/Cu 4-Row Evap, Cycling HGRH on Lead Circuit with Vari-Speed Cond Fan
- J - Al/Cu Cond, Al/Cu 4-Row Evap, Cycling HGRH on Both Circuits, with Vari-Speed Cond Fan
- M - Al/Cu Cond, Al/Cu 4-Row Evap, Modulating HGRH on Lead Circuits, with Vari-Speed Cond Fan
- N - Al/Cu Cond, Al/Cu 4-Row Evap, Modulating HGRH on Both Circuits, with Vari-Speed Cond Fan
- T - Al/Cu Cond, Al/Cu 6-Row, no HGRH, with Cycling Cond Fan
- V - Al/Cu Cond, Al/Cu 6-Row Evap, no HGRH, with Vari-Speed Cond Fan
- Y - Al/Cu Cond, Al/Cu 6-Row Evap, Cycling HGRH on Lead Circuit with Vari-Speed Cond Fan
- Z - Al/Cu Cond, Al/Cu 6-Row Evap, Cycling HGRH on Both Circuits with Vari-Speed Cond Fan
- 3 - Al/Cu Cond, Al/Cu 6-Row Evap, Modulating HGRH on Lead Circuit with Vari-Speed Cond Fan
- 4 - Al/Cu Cond, Al/Cu 6-Row Evap, Modulating HGRH on Both Circuits, with Vari-Speed Cond Fan
- 7 - Al/Cu Cond, Al/Cu 6-Row Evap, Cycling HGRH on Both Circuits, with Vari-Speed Cond Fan, with Sub Cooling on All Circuits
- 8 - Al/Cu Cond, Al/Cu 6-Row Evap, Modulating HGRH on Both Circuits, with Vari-Speed Cond Fan, with Sub Cooling on All Circuits

Voltage Options

- 4 - 208-3-60 with Std Compressor
- 5 - 230-3-60 with Std Compressor
- 6 - 460-3-60 with Std Compressor
- B - 208-3-60 with Digital Compressor
- C - 230-3-60 with Digital Compressor
- D - 460-3-60 with Digital Compressor
- F - 208-3-60 with Std Compressor and LonWorks
- G - 230-3-60 with Std Compressor and LonWorks
- H - 460-3-60 with Std Compressor and LonWorks
- K - 208-3-60 with Digital Compressor and LonWorks
- L - 230-3-60 with Digital Compressor and LonWorks
- M - 460-3-60 with Digital Compressor and LonWorks

LEGEND

- | | |
|-------------------------------|---------------------------------------|
| AF — Airfoil | FC — Forward Curve |
| Al — Aluminum | HGRH — Hot Gas Reheat |
| BC — Backward Curve | OA — Outdoor Air |
| BI — Backward Inclined | RA — Return Air |
| Byp — Bypass | TD — Temperature Defrost |
| Cu — Copper | VFD — Variable Frequency Drive |

Factory Installed Options

Refer to price pages for available option codes

Fan Size

- A - Standard FC Supply Fan
- B - Standard BC Supply Fan
- C - Standard AF Supply Fan
- D - Oversize AF Supply Fan
- E - Standard BI Supply Fan
- F - Oversize BI Supply Fan
- G - Standard FC Supply Fan and Standard FC Exhaust Fan
- H - Standard FC Supply Fan and Oversize FC Exhaust Fan
- J - Standard FC Supply Fan and Standard BC Supply Fan
- K - Standard FC Supply Fan and Standard AF Exhaust Fan
- L - Standard BC Supply Fan and Standard FC Exhaust Fan
- M - Standard BC Supply Fan and Oversize FC Exhaust Fan
- N - Standard BC Supply Fan and Standard BC Exhaust Fan
- P - Standard BC Supply Fan and Standard AF Exhaust Fan
- Q - Standard AF Supply Fan and Standard FC Exhaust Fan
- R - Standard AF Supply Fan and Oversize FC Exhaust Fan
- S - Standard AF Supply Fan and Standard AF Exhaust Fan
- T - Standard AF Supply Fan and Standard AF Exhaust Fan
- V - Standard AF Supply Fan and Oversize AF Exhaust Fan
- W - Oversize AF Supply Fan and Standard BC Exhaust Fan
- X - Oversize AF Supply Fan and Standard AF Exhaust Fan
- Y - Oversize AF Supply Fan and Oversize AF Exhaust Fan
- Z - Standard BI Supply Fan and Standard FC Exhaust Fan
- 1 - Standard BI Supply Fan and Oversize FC Exhaust Fan
- 2 - Standard BI Supply Fan and Standard BC Exhaust Fan
- 3 - Standard BI Supply Fan and Standard AF Exhaust Fan
- 4 - Standard BI Supply Fan and Oversize AF Exhaust Fan
- 5 - Oversize BI Supply Fan and Standard FC Exhaust Fan
- 6 - Oversize BI Supply Fan and Oversize FC Exhaust Fan
- 7 - Oversize BI Supply Fan and Standard BC Exhaust Fan
- 8 - Oversize BI Supply Fan and Standard AF Exhaust Fan
- 9 - Oversize BI Supply Fan and Oversize AF Exhaust Fan

Exhaust Fan Motor Options

- | | |
|--------------|-----------------------|
| - - None | L - 20 HP |
| A - 1/2 HP | N - 1 HP with VFD |
| B - 3/4 HP | P - 1 1/2 HP with VFD |
| C - 1 HP | Q - 2 HP with VFD |
| D - 1 1/2 HP | R - 3 HP with VFD |
| E - 2 HP | S - 5 HP with VFD |
| F - 3 HP | T - 7 1/2 HP with VFD |
| G - 5 HP | V - 10 HP with VFD |
| H - 7 1/2 HP | W - 15 HP with VFD |
| J - 10 HP | X - 20 HP with VFD |
| K - 15 HP | |

Packaging / Filter Options

- 1 - Domestic / 2" MERV 8 Filter
- A - Domestic / 2" Metal Mesh Filter
- B - Domestic / 4" MERV 8 Filter
- C - Domestic / 4" MERV 11 Filter
- D - Domestic / 4" MERV 14 Filter
- E - Domestic / 2" MERV 8 Filter and 2" MERV 8 ECW Filter
- F - Domestic / 2" Metal Mesh Filter and 2" MERV 8 ECW Filter
- G - Domestic / 4" MERV 8 Filter and 2" MERV 8 ECW Filter
- H - Domestic / 4" MERV 11 Filter and 2" MERV 8 ECW Filter
- J - Domestic / 4" MERV 14 Filter and 2" MERV 8 ECW Filter

Design Series

- 3 - Revision E Controls

* Horizontal units with heat require a BI fan.

† Control valves must be field supplied.

** Energy Conservation Wheel (ECW) options are not available on DA and DB models.

Ratings and capacities



GAS HEAT CAPACITIES

UNIT SIZE 62D	INPUT (Btuh)	OUTPUT (Btuh)	NO. OF GAS HEAT SECTIONS	NO. OF STAGES	MODULATION RANGE (%)	MINIMUM ENTERING AIR TEMP (F)	MAXIMUM ENTERING AIR TEMP (F)	MINIMUM TEMP RISE (F)	MAXIMUM TEMP RISE (F)	MINIMUM LEAVING AIR TEMP (F)	MAXIMUM LEAVING AIR TEMP (F)
07-09	75,000	60,000	1	2	25-100	-20	75	25	90	50	165
	100,000	80,000	1	2	25-100						
	150,000	120,000	1	2	25-100						
	200,000	160,000	1	2	25-100						
12-20	150,000	120,000	1	2	25-100						
	200,000	160,000	1	2	25-100						
	250,000	200,000	1	2	25-100						
	300,000	240,000	1	2	25-100						
22-38	300,000	240,000	1	2	25-100						
	400,000	320,000	1	2	25-100						
	500,000	400,000	2	4	12.5-100						
	600,000	480,000	2	4	12.5-100						

HYDRONIC HEATING COIL CAPACITIES

UNIT SIZE 62D	CFM	ENTERING AIR TEMP (F)	STEAM COIL			HOT WATER COIL					
			Steam Temp at 5 psig (F)	Total Btuh (1000)	Leaving Air Temp (F)	Entering Water Temp (F)	Entering Water Flow (gpm)	Total Btuh (1000)	Leaving Air Temp (F)	Leaving Water Temp (F)	Water Pressure Drop (ft wg)
07-09	1,300	70	180	87.7	132.2	180	10.9	106.2	145.3	160.5	1.1
	3,000	70	180	200.0	130.1	180	20.1	200.4	131.6	160.1	1.9
12-20	1,300	70	180	87.7	132.2	180	10.9	106.2	145.3	160.5	1.1
	3,900	70	180	255.0	130.3	180	26.2	260.6	131.6	160.1	2.1
	6,500	70	180	345.2	118.9	180	35.7	346.7	119.2	160.6	3.7
22-38	5,000	70	180	370.3	138.3	180	48.9	475.5	157.6	160.6	1.4
	8,000	70	180	493.9	126.9	180	68.0	662.0	146.3	160.5	2.7
	11,000	70	180	590.2	119.5	180	84.4	810.9	137.9	160.8	3.9

STEAM HEATING COIL CAPACITIES

UNIT SIZE 62D	CFM		ENTERING AIR TEMPERATURE — EDB (F)						
			-20	-10	0	10	20	30	40
07-09	1,300	TC	155.1	148.9	142.6	136.3	130.0	123.8	117.5
		LDB	89.6	95.1	100.7	106.3	111.9	117.4	123.0
	2,100	TC	206.3	197.9	189.6	181.2	172.9	164.6	156.2
		LDB	70.2	76.5	82.9	89.3	95.6	102.0	108.3
	3,000	TC	250.5	240.4	230.2	220.1	210.0	199.9	189.7
		LDB	56.7	63.6	70.5	77.1	84.3	91.2	98.1
12-20	1,300	TC	155.1	148.9	142.6	136.3	130.0	123.8	117.5
		LDB	89.6	95.1	100.7	106.3	111.9	117.4	123.0
	3,900	TC	297.7	286.1	263.0	251.4	239.9	228.3	216.8
		LDB	40.1	47.4	61.9	69.2	76.5	83.8	91.0
	6,000	TC	349.8	335.7	321.5	307.4	293.3	279.1	265.0
		LDB	33.5	41.4	49.2	57.0	64.9	72.7	80.6
22-38	5,000	TC	441.2	423.4	405.5	387.7	369.9	352.0	334.2
		LDB	61.0	67.8	74.5	81.2	87.9	94.7	101.4
	8,000	TC	560.5	537.8	515.2	492.5	469.9	447.2	424.6
		LDB	44.3	51.7	59.1	66.5	73.9	81.3	88.7
	12,000	TC	674.7	647.4	620.1	592.9	565.6	538.3	511.1
		LDB	31.6	39.5	47.5	55.4	63.3	71.2	79.1

LEGEND

- EDB — Entering Air Temperature (F)
- LDB — Leaving Dry Bulb Temperature (F)
- TC — Total Capacity (1000 Btuh)

NOTE: 6500 cfm is 542 ft per minute velocity (face).

ENERGY CONSERVATION WHEEL CAPACITIES

UNIT SIZE 62DC,DD	WHEEL DIAMETER (in.)	WHEEL THICKNESS (in.)	MAXIMUM AIRFLOW (cfm)	AIR PRESSURE DROP (in. wg)	HEATING			
					Return Air Temp (db/wb)(F)	Entering Outdoor Air Temp (F)	Leaving Air Temp (F)	Sensible Btuh
07-09	36	4	3000	1.37	70.0/58.0	0.0	42.5	144,892
12-20	36	4	2700	1.23	70.0/58.0	0.0	42.5	136,215
	48	4	4500	1.15	70.0/58.0	0.0	47.3	233,423
22-38	42	4	3600	1.20	70.0/58.0	0.0	43.1	183,432
	48	4	4500	1.15	70.0/58.0	0.0	47.3	233,423
	54	4	8000	1.15	70.0/58.0	0.0	48.4	368,300

LEGEND

db — Dry Bulb Temperature
wb — Wet Bulb Temperature

ELECTRIC HEAT CAPACITIES

UNIT SIZE 62D	ELECTRIC HEAT kW (240,480 / 208)	AMPS			MINIMUM ENTERING AIR TEMP (F)	MAXIMUM ENTERING AIR TEMP (F)	MINIMUM TEMP RISE (F)	MAXIMUM TEMP RISE (F)	MINIMUM LEAVING AIR TEMP (F)	MAXIMUM LEAVING AIR TEMP (F)
		240 v	480 v	208 v						
07-09	10.0 / 7.5	24.1	12.0	20.8	-20	75	N/A	76	N/A	151
	15.0 / 11.3	36.1	18.0	31.4						
	20.0 / 15.0	48.1	24.1	41.6						
	25.0 / 18.8	60.1	30.1	52.2						
	30.0 / 22.6	72.2	36.1	62.5						
	35.0 / 26.3	84.2	42.1	73.0						
	40.0 / 30.0	96.2	48.1	83.3						
12-20	10.0 / 7.5	24.1	12.0	20.8						
	15.0 / 11.3	36.1	18.0	31.4						
	20.0 / 15.0	48.1	24.1	41.6						
	25.0 / 18.8	60.1	30.1	52.2						
	30.0 / 22.6	72.2	36.1	62.5						
	35.0 / 26.3	84.2	42.1	73.0						
	40.0 / 30.0	96.2	48.1	83.3						
22-38	50.0 / 37.5	120.3	60.1	104.1						
	60.0 / 45.0	144.3	72.2	124.9						
	10.0 / 7.5	24.1	12.0	20.8						
	15.0 / 11.3	36.1	18.0	31.4						
	20.0 / 15.0	48.1	24.1	41.6						
	30.0 / 22.6	72.2	36.1	62.5						
	40.0 / 30.0	96.2	48.1	83.3						
22-38	50.0 / 37.5	120.3	60.1	104.1						
	60.0 / 45.0	144.3	72.2	124.9						

AIRFLOW LIMITS

UNIT SIZE 62D	62DA,DB,DC,DD*		62DC,DD†	
	Min. CFM	Max. CFM	Min. CFM	Max. CFM
07	700	1,500	1,500	2,500
08	800	1,800	1,800	3,000
09	900	2,100	2,100	3,500
12	1,100	2,200	2,200	3,700
14	1,350	2,900	2,900	4,600
15	1,700	3,600	3,600	5,800
16	2,000	4,400	4,400	6,500
20	2,400	4,400	4,400	6,500
22	2,400	4,400	4,400	6,500
24	2,400	6,000	6,000	9,000
30	3,400	9,000	7,000	11,000
34	4,000	8,000	8,000	12,000
38	4,800	9,000	9,000	12,000

*Units without ECW.

† 62DC and DD with ECW.

Physical data — 62DA,DB units



UNIT 62DA,DB	07	08	09	12	14	15	16
NOMINAL CAPACITY (TONS)	6	7	8	10	12	14	15
COMPRESSOR Quantity/Unit ... Model	1 ... ZP51	1 ... ZP61	1 ... ZP72	2 ... ZP42	2 ... ZP51	2 ... ZP67	2 ... ZP83
Number of Refrigerant Circuits	1			2			
Oil	Pre-Charged			Pre-Charged			
REFRIGERANT TYPE Operating Charge per circuit (lb-oz)	12-13	R-410A 15-1	15-3	14-9	R-410A 14-8	16-8	16-3
CONDENSER COIL Rows ... Fins/in. Face Area (sq ft)	2 ... 16 12.38			2 ... 16 24.75			
CONDENSER FAN Nominal Cfm (total) Quantity ... Diameter (in.) Motor Hp	4000 1 ... 24 1/2	5500 1 ... 26 3/4		8000 2 ... 24 1/2		11,000 2 ... 26 3/4	
HIGH-PRESSURE SWITCH (PSIG) Cutout Reset (Manual)				640 595			
EVAPORATOR COIL Tube Size (in.) Rows ... Fins/in. Face Area (sq ft)	3.00	6.25		3/8 6 ... 12	8.0	12.0	
SUPPLY FAN Backward Curved (mm) Forward Curved (in.) Airfoil (in.) Oversize Airfoil (in.) Backward Inclined (in.) Oversize Backward Inclined (in.) Nominal Cfm 100% OA Motor Hp Range	1000	1200 1/2 - 5	1400	1500 3/4 - 5	1900	2300 1 - 10	2800
OPTIONAL HOT GAS REHEAT AND LIQUID SUBCOOLING COIL Face Area (sq ft) Tube Size (in.)	3	6.25		3/8 8		12	
LOW-PRESSURE SWITCH (PSIG) Cutout Reset (Auto)				99 135			
CONDENSATE DRAIN CONNECTION (NPT) (in.)				1 1/4			
OPTIONAL GAS HEAT FURNACE SECTION Gas Input Sizes (Btuh x 1000) Control Type Staged (no. of stages) Modulating (% range) Efficiency (Steady State) (%) Supply Line Pressure Range (in. wg) Rollout Switch Cutout Temp (F) Gas Valve Quantity Manifold Pressure (in. wg) Natural Gas Std LP Gas Special Order	75, 100, 150, 200			150, 200, 250, 300			
	2 10 - 100 82			2 10 - 100 82			
	5.0 min. - 13.0 max. 350			5.0 min. - 13.0 max. 350			
	1 Std - 2 with Modulating Option			1 Std - 2 with Modulating Option			
	3.5 10.0			3.5 10.0			
OPTIONAL ELECTRIC HEAT Size Range (kW) Control Type Staged (no. of stages) SCR (% range)	10,15,20,25,30,35,40			10,15,20,25,30,35,40,50,60			
	2 0 - 100			2 0 - 100			
OPTIONAL HOT WATER HEAT COIL	24 x 38 in., 2 Row, 10 FPI, with 1/2-in. Tube Size						
OPTIONAL STEAM HEAT COIL	24 x 38 in., 1 Row, 8 FPI, with 5/8-in. Tube Size						
OUTDOOR AIR FILTERS Quantity ... Size (in.) Standard 2 in. MERV 8 Optional 2 in. Metal Mesh Optional 4 in. MERV 8 MERV 11 MERV 14	4 ... 20x24 4 ... 20x24			4 ... 20x24 4 ... 20x24			
	4 ... 20x24 4 ... 20x24 4 ... 20x24			4 ... 20x24 4 ... 20x24 4 ... 20x24			

LEGEND

- FPI — Fins per Inch
- LP — Liquid Propane
- OA — Outdoor Air
- SCR — Silicon-Controlled Rectifier

UNIT 62DA,DB	20	22	24	30	34	38
NOMINAL CAPACITY (TONS)	18	19	20	27	30	35
COMPRESSOR Quantity/Unit ... Model Number of Refrigerant Circuits Oil	2 ... ZP90	2 ... ZP90	2 ... ZP103	2 ... ZP137	2 ... ZP180	2 ... ZP90/2 ... ZP90
REFRIGERANT TYPE Operating Charge per circuit (lb-oz)	Pre-Charged R-410A					
CONDENSER COIL Rows ... Fins/in. Face Area (sq ft)	17-1	25-1	25-5	25-10	26-4	32-1
CONDENSER FAN Nominal Cfm (total) Quantity ... Diameter (in.) Motor Hp	2 ... 16 24.75	2 ... 16 42.6			3 ... 12	
HIGH-PRESSURE SWITCH (PSIG) Cutout Reset (Manual)	11,000 2 ... 26 3/4	11,000 2 ... 26 1		640 595		
EVAPORATOR COIL Tube Size (in.) Rows ... Fins/In. Face Area (sq ft)	12.0	15.3	6 ... 12 3/8		23.0	
SUPPLY FAN Backward Curved (mm) Forward Curved (in.) Airfoil (in.) Oversize Airfoil (in.) Backward Inclined (in.) Oversize Backward Inclined (in.) Nominal Cfm 100% OA Motor Hp Range	12 x 12 15 x 15 15 18.5 3100 1 1/2 - 10	2900 1 1/2 - 10	3600 1 1/2 - 15	4600	5300	6200 2 - 20
OPTIONAL HOT GAS REHEAT AND LIQUID SUBCOOLING COIL Face Area (sq ft) Tube Size (in.)	12	15.3	3/8		23	
LOW-PRESSURE SWITCH (PSIG) Cutout Reset (Auto)				99 135		
CONDENSATE DRAIN CONNECTION (NPT) (in.)	1 1/4					
OPTIONAL GAS HEAT FURNACE SECTION Gas Input Sizes (Btuh x 1000) Control Type Staged (no. of stages) Modulating (% range) Efficiency (Steady State) (%) Supply Line Pressure Range (in.wg) Rollout Switch Cutout Temp (F) Gas Valve Quantity Manifold Pressure (in. wg) Natural Gas Std LP Gas Special Order	150, 200, 250, 300	300, 400, 500, 600				
	2	2 (Low Heat) / 4 (High Heat) 10 - 100 82 5.0 min. - 13.0 max. 350 1 Std - 2 with Modulating Option				
		3.5 10.0				
OPTIONAL ELECTRIC HEAT Size Range (kW) Control Type Staged (no. of stages) SCR (% range)	10,15,20,25,30, 35,40,50,60	10,15,20,30,40,50,60				
		2 0 - 100				
OPTIONAL HOT WATER HEAT COIL	45 x 38 in., 2 Row, 10 FPI, with 5/8-in. Tube Size					
OPTIONAL STEAM HEAT COIL	45 x 38 in., 1 Row, 8 FPI, with 5/8-in. Tube Size					
OUTDOOR AIR FILTERS Quantity ... Size (in.) Standard 2 in. MERV 8 Optional 2 in. Metal Mesh Optional 4 in. MERV 8 MERV 11 MERV 14	4 ... 20x24 4 ... 20x24 4 ... 20x24 4 ... 20x24 4 ... 20x24 4 ... 20x24	2 ... 20x24, 2 ... 24x24 2 ... 20x24, 2 ... 24x24 2 ... 20x24, 2 ... 24x24 2 ... 20x24, 2 ... 24x24 2 ... 20x24, 2 ... 24x24				

LEGEND

- FPI — Fins per Inch
- LP — Liquid Propane
- OA — Outdoor Air
- SCR — Silicon-Controlled Rectifier

Physical data — 62DC,DD units



UNIT 62DC,DD WITH ECW	07	08	09	12	14	15	16	20
NOMINAL CAPACITY (TONS)	6	7	8	10	12	14	15	18
COMPRESSOR Quantity/Unit ... Model Number of Refrigerant Circuits Oil	1 ... ZP51	1 ... ZP61 1 Pre-Charged	1 ... ZP72	2 ... ZP42	2 ... ZP51	2 ... ZP67 2 Pre-Charged	2 ... ZP83	2 ... ZP90
REFRIGERANT TYPE Operating Charge per Circuit (lb-oz)	12-13	R-410A 15-1	15-3	14-9	14-8	R-410A 16-8	16-3	17-1
CONDENSER COIL Rows ... Fins/in. Face Area (sq ft)		2 ... 16 12.38				2 ... 16 24.75		
CONDENSER FAN Nominal Cfm (total) Quantity ... Diameter (in.) Motor Hp	4000 1 ... 24 1/2	5500 1 ... 26 3/4		8000 2 ... 24 1/2			11,000 2 ... 26 3/4	
HIGH-PRESSURE SWITCH (PSIG) Cutout Reset (Manual)				640 595				
EVAPORATOR COIL* Tube Size (in.) Rows ... Fins/in. Face Area (sq ft)	4.0	3/8 4 ... 12 7.5		3/8 4 ... 12 12.0		3/8 6 ... 12 12.0		
SUPPLY FAN Backward Curved (mm) Forward Curved (in.) Airfoil (in.) Oversize Airfoil (in.) Backward Inclined (in.) Oversize Backward Inclined (in.) Nominal Cfm 100% OA Motor Hp Range	1000	180 12 x 9 12 x 12 N/A 15 18.5 1200 1/2 - 5	1400	1500 3/4 - 5	1900	N/A N/A 12 x 12 15 x 15 15 18.5 2300 1 - 10	2800	3100 1 1/2 - 10
OPTIONAL HOT GAS REHEAT AND LIQUID SUBCOOLING COIL Face Area (sq ft) Tube Size (in.)	4	7.5		3/8		12		
LOW-PRESSURE SWITCH (PSIG) Cutout Reset (Auto)				99 135				
CONDENSATE DRAIN CONNECTION (NPT) (in.)				1 1/4				
OPTIONAL GAS HEAT FURNACE SECTION Gas Input Sizes (Btuh x 1000) Control Type Staged (no. of stages) Modulating (% range) Efficiency (Steady State) (%) Supply Line Pressure Range (in. wg) Rollout Switch Cutout Temp (F) Gas Valve Quantity Gas Connect Size (in.) Manifold Pressure (in. wg) Natural Gas Std LP Gas Special Order		75, 100, 150, 200 2 10 - 100 82 5.0 min. - 13.0 max. 350 1 Std - 2 with Modulating Option 3/4 3.5 10.0		150, 200, 250, 300 2 10 - 100 82 5.0 min. - 13.0 max. 350 1 Std - 2 with Modulating Option 3/4 3.5 10.0				
OPTIONAL ELECTRIC HEAT Size Range (kW) Control Type Staged (no. of stages) SCR (% range)		10,15,20,25,30,35,40 2 0 - 100				10,15,20,25,30,35,40,50,60 2 0 - 100		
OPTIONAL HOT WATER HEAT COIL				24 x 38 in., 2 Row, 10 FPI, with 1/2-in. Tube Size				
OPTIONAL STEAM HEAT COIL				24 x 38 in., 1 Row, 8 FPI, with 5/8-in. Tube Size				
OUTDOOR AIR FILTERS Quantity ... Size (in.) Standard 2 in. MERV 8 Optional 2 in. Metal Mesh Optional 4 in. MERV 8 MERV 11 MERV 14				4 ... 20x24 4 ... 20x24				
OPTIONAL ECW Type Size (in.)		Molecular Sieve 36				Molecular Sieve 36 or 48		
OPTIONAL ECW FILTERS Quantity ... Size (in.) with 36 in. ECW with 42 in. ECW with 48 in. ECW with 54 in. ECW		2 ... 20x24, 2 ... 20x20 N/A N/A N/A				2 ... 20x24, 2 ... 20x20 N/A 4 ... 20x24, 2 ... 12x24 N/A		
OPTIONAL EXHAUST FAN Backward Curved (mm) Forward Curved (in.) Oversize Forward Curved (in.) Airfoil (in.) Oversize Airfoil (in.) Motor Hp Range		180 mm 9 x 7 12 x 9 12 x 12 N/A 1/2 - 5				180 mm N/A N/A 12 x 12 N/A 1/2 - 10		

LEGEND
FPI — Fins per Inch
LP — Liquid Propane
OA — Outdoor Air
SCR — Silicon-Controlled Rectifier

* 62DC,DD units without the ECW (Energy Conservation Wheel) option use a 6-row evaporator coil.

UNIT 62DC,DD WITH ECW	22	24	30	34	38
NOMINAL CAPACITY (TONS)	19	20	27	30	35
COMPRESSOR Quantity/Unit ... Model Number of Refrigerant Circuits Oil	2 ... ZP90	2 ... ZP103	2 ... ZP137 2 Pre-Charged	2 ... ZP180	2 ... ZP90/2 ... ZP90
REFRIGERANT TYPE Operating Charge per Circuit (lb-oz)	25-1	25-5	R-410A 25-10	26-4	32-1
CONDENSER COIL Rows ... Fins/in. Face Area (sq ft)	2 ... 16 42.6				3 ... 12
CONDENSER FAN Nominal Cfm (total) Quantity ... Diameter (in.) Motor Hp	11,000 2 ... 26 1		20,000 2 ... 30 1 1/2		
HIGH-PRESSURE SWITCH (PSIG) Cutout Reset (Manual)	640 595				
EVAPORATOR COIL* Tube Size (in.) Rows ... Fins/in. Face Area (sq ft)	3/8 4 ... 12 23.0				3/8 6 ... 12 23.0
SUPPLY FAN Backward Curved (mm) Forward Curved (in.) Airfoil (in.) Oversize Airfoil (in.) Backward Inclined (in.) Oversize Backward Inclined (in.) Nominal Cfm 100% OA Motor Hp Range	2900 1 1/2 - 10	3600 1 1/2 - 15	4600 27	5300 2 - 20	6200
OPTIONAL HOT GAS REHEAT AND LIQUID SUBCOOLING COIL Face Area (sq ft) Tube Size (in.)	12	23 3/8			
LOW-PRESSURE SWITCH (PSIG) Cutout Reset (Auto)	99 135				
CONDENSATE DRAIN CONNECTION (NPT) (in.)	1 1/4				
OPTIONAL GAS HEAT FURNACE SECTION Gas Input Sizes (MBtuh) Control Type Staged (no. of stages) Modulating (% range) Efficiency (Steady State) (%) Supply Line Pressure Range (in. wg) Rollout Switch Cutout Temp (F) Gas Valve Quantity Gas Connect Size (in.) Manifold Pressure (in. wg) Natural Gas Std LP Gas Special Order	300, 400, 500, 600 2 (300 and 400) / 4 (500 and 600) 10 - 100 82 5.0 min. - 13.0 max. 350 1 Std - 2 with Modulating Option 3/4 3.5 10.0				
OPTIONAL ELECTRIC HEAT Size Range (kW) Control Type Staged (no. of stages) SCR (% range)	10,15,20,30,40,50,60 2 0 - 100				
OPTIONAL HOT WATER HEAT COIL	45 x 38 in., 2 Row, 10 FPI, with 5/8-in. Tube Size				
OPTIONAL STEAM HEAT COIL	45 x 38 in., 1 Row, 8 FPI, with 5/8-in. Tube Size				
OUTDOOR AIR FILTERS Quantity ... Size (in.) Standard 2 in. MERV 8 Optional 2 in. Metal Mesh Optional 4 in. MERV 8 MERV 11 MERV 14	2 ... 20x24, 2 ... 24x24 2 ... 20x24, 2 ... 24x24 2 ... 20x24, 2 ... 24x24 2 ... 20x24, 2 ... 24x24 2 ... 20x24, 2 ... 24x24				
OPTIONAL ECW Type Size (in.)	Molecular Sieve 42, 48, or 54				
OPTIONAL ECW FILTERS Quantity ... Size (in.) with 36 in. ECW with 42 in. ECW with 48 in. ECW with 54 in. ECW	N/A 4 ... 20x24, 2 ... 12x24 6 ... 18x24 6 ... 18x24				
OPTIONAL EXHAUST FAN Backward Curved (mm) Forward Curved (in.) Oversize Forward Curved (in.) Airfoil (in.) Oversize Airfoil (in.) Motor Hp Range	180 N/A N/A 15 x 15 18 x 18 1/2 - 20				

LEGEND

FPI — Fins per Inch
LP — Liquid Propane
OA — Outdoor Air
SCR — Silicon-Controlled Rectifier

* 62DC,DD units without the ECW (Energy Conservation Wheel) option use a 6-row evaporator coil.

Physical data (cont)



UNIT AND COMPONENT WEIGHTS (lb)

COMPONENT	62D UNIT SIZE												
	07	08	09	12	14	15	16	20	22	24	30	34	38
Base Unit	1650	1690	1710	1910	1960	2120	2060	2080	3375	3475	3575	3655	4075
Hot Gas Reheat	35	35	35	75	75	75	75	75	120	120	120	120	120
Liquid Subcooling Coil	25	25	25	55	55	55	55	55	100	100	100	100	100
Gas Furnace (Btuh)													
75,000	140	140	140	—	—	—	—	—	—	—	—	—	—
100,000	150	150	150	—	—	—	—	—	—	—	—	—	—
150,000	160	160	160	160	160	160	160	160	—	—	—	—	—
200,000	170	170	170	170	170	170	170	170	—	—	—	—	—
250,000	—	—	—	210	210	210	210	210	—	—	—	—	—
300,000	—	—	—	250	250	250	250	250	250	250	250	250	250
400,000	—	—	—	—	—	—	—	—	275	275	275	275	275
500,000	—	—	—	—	—	—	—	—	420	420	420	420	420
600,000	—	—	—	—	—	—	—	—	500	500	500	500	500
Electric Heater	75	75	75	75	75	75	75	75	100	100	100	100	100
Steam Coil	60	60	60	60	60	60	60	60	120	120	120	120	120
Hot Water Coil	75	75	75	75	75	75	75	75	150	150	150	150	150
Wheel Bypass Dampers	60	60	60	60	60	60	60	60	125	125	125	125	125
Energy Conservation Wheel	350	350	350	420	420	420	420	420	470	470	470	470	470
Power Exhaust	345	345	345	375	375	375	375	375	525	525	525	525	525
Curb 14-in.	275	275	275	275	275	275	275	275	305	305	305	305	305
Curb 24-in.	375	375	375	375	375	375	375	375	425	425	425	425	425



Options and accessories



ITEM	OPTION*	ACCESSORY†
Heat Options		
Staged Gas Heat (LP or NG)	X	
Modulating Gas Heat (10:1 or 5:1 Turndown)	X	
Staged Electric Heat	X	
SCR Controlled Electric Heat	X	
Hot Water Heating Coil	X	
Steam Heating Coil	X	
NG to LP Conversion Kit		X
Energy Conservation Wheel	X	
Wheel VFD Defrost Control	X	
Wheel Bypass Dampers	X	
Control Options		
Filter Status Switch	X	
Return Air Smoke Detector	X	
Convenience Outlet	X	
Fused Disconnect Switch	X	
Lead Circuit Digital Compressor	X	
BACview Keypad/Display		X
LonWorks Communication	X	
Variable Speed Condenser Fans	X	
Coil Options		
Hot Gas Reheat	X	
Liquid Subcooling Coil	X	
Corrosion Protection	X	
Filter Options		
2-in. MERV 8 Filters	X	X
4-in. MERV 8 Filters	X	X
4-in. MERV 11 Filters	X	X
4-in. MERV 14 Filters	X	
2-in. Metal Mesh Filters	X	
Supply Fan Options		
Backward Curved Fan	X	
Forward Curved Fan	X	
Airfoil Fan	X	
Oversize Airfoil Fan	X	
Backward Inclined Fan	X	
Oversize Backward Inclined Fan	X	
VFD Control	X	
Exhaust Fan Options		
Backward Curved Fan	X	
Forward Curved Fan	X	
Oversized Forward Curved Fan	X	
Airfoil Fan	X	
Oversize Airfoil Fan	X	
VFD Control	X	
14-in. Factory-Assembled Roof Curb		X
24-in. Factory-Assembled Roof Curb		X
14-in. Field-Assembled Roof Curb		X
24-in. Field-Assembled Roof Curb		X
Spring Type Fan Isolation	X	
Firestat	X	

LEGEND

- LP — Liquid Propane
- NG — Natural Gas
- SCR — Silicon Controlled Rectifier
- VFD — Variable Frequency Drive

*Factory installed.
†Field installed.

Base unit dimensions — 62DA,DB07-09

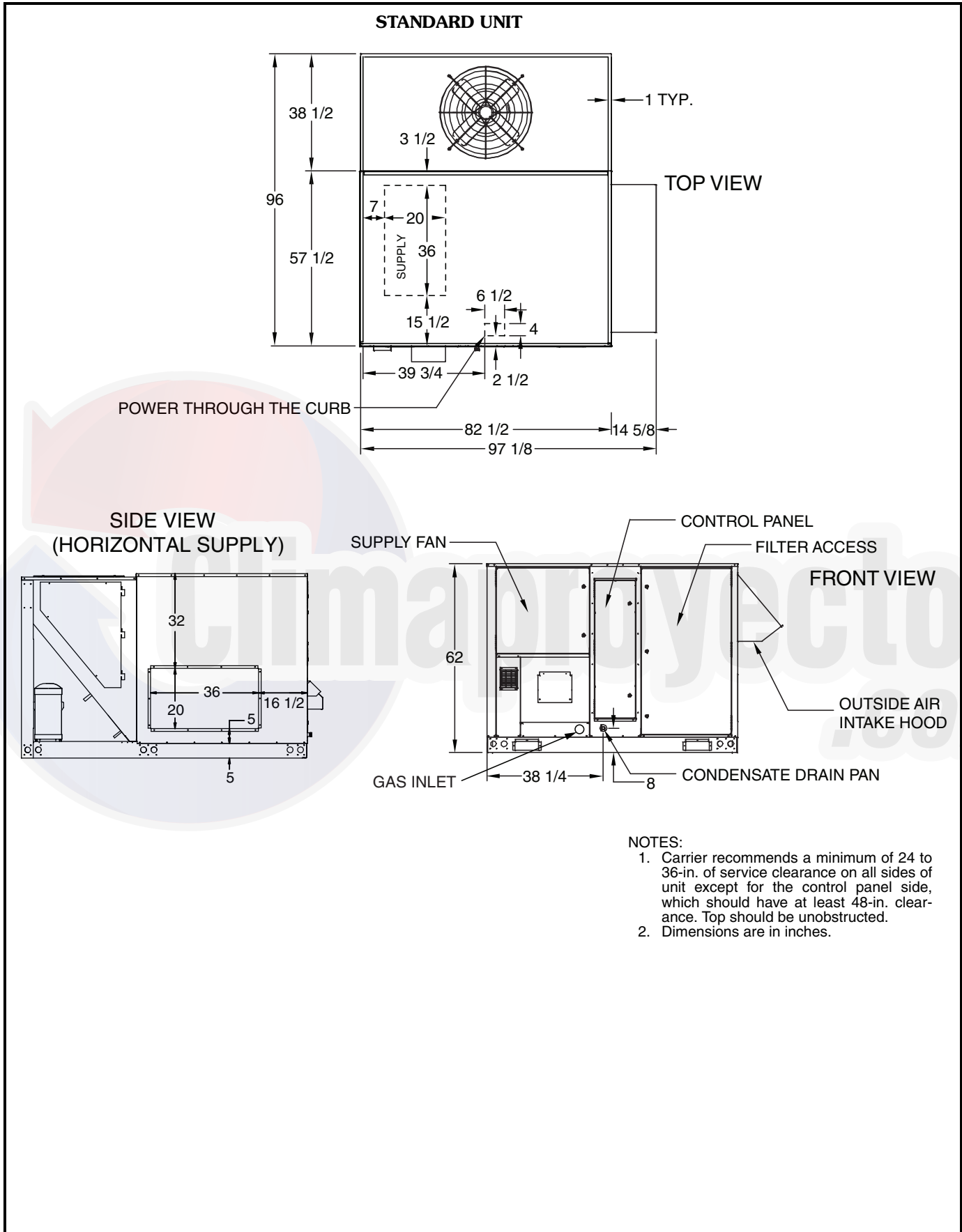

Base unit dimensions — 62DC,DD07-09



UNIT WITH OPTIONAL EXHAUST

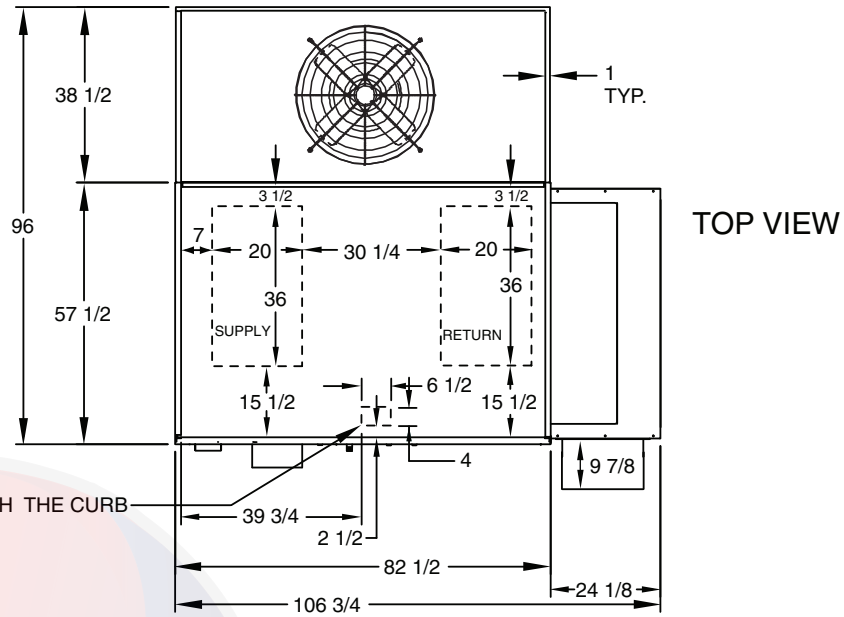

SIDE VIEW (HORIZONTAL SUPPLY)

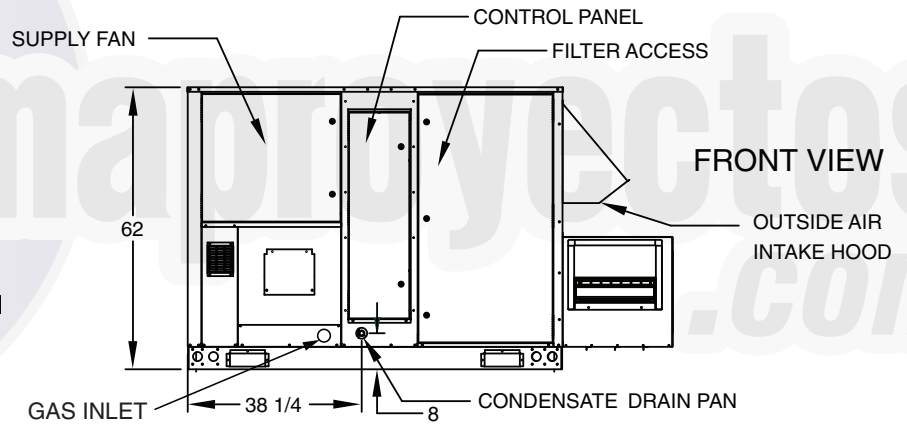
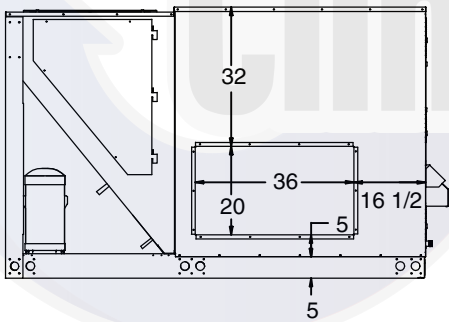

NOTES:

1. Carrier recommends a minimum of 24 to 36-in. of service clearance on all sides of unit except for the control panel side, which should have at least 48-in. clearance. Top should be unobstructed.
2. Dimensions are in inches.

Base unit dimensions — 62DC,DD07-09 (cont)



UNIT WITH OPTIONAL ENERGY CONSERVATION WHEEL

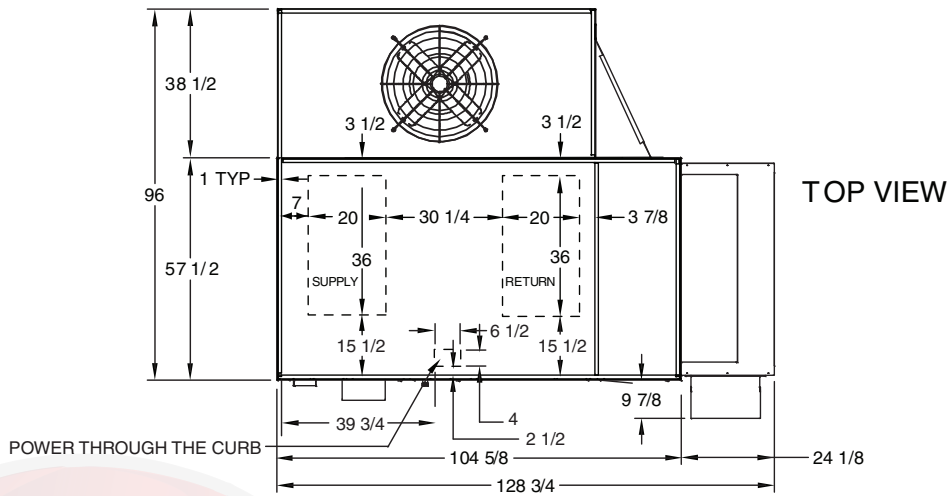

SIDE VIEW (HORIZONTAL SUPPLY)

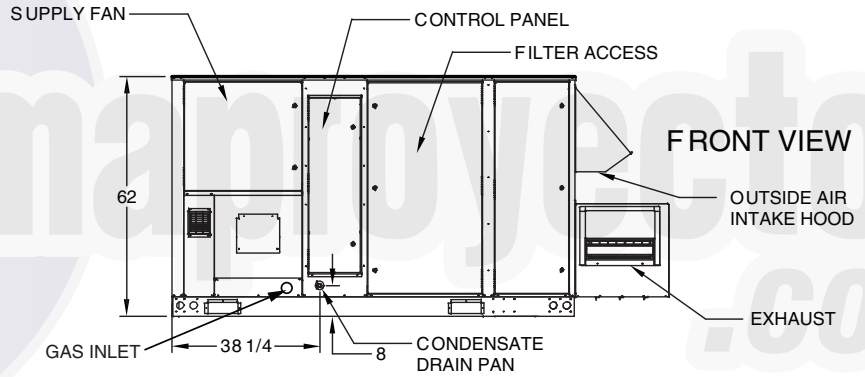
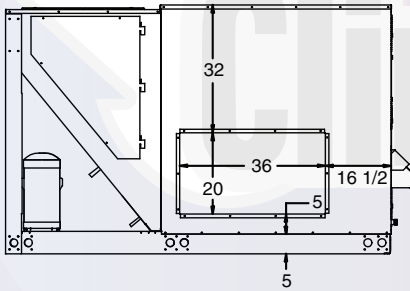

NOTES:

- Carrier recommends a minimum of 24 to 36-in. of service clearance on all sides of unit except for the control panel side, which should have at least 48-in. clearance. Top should be unobstructed.
- Dimensions are in inches.

Base unit dimensions — 62DA,DB12-20

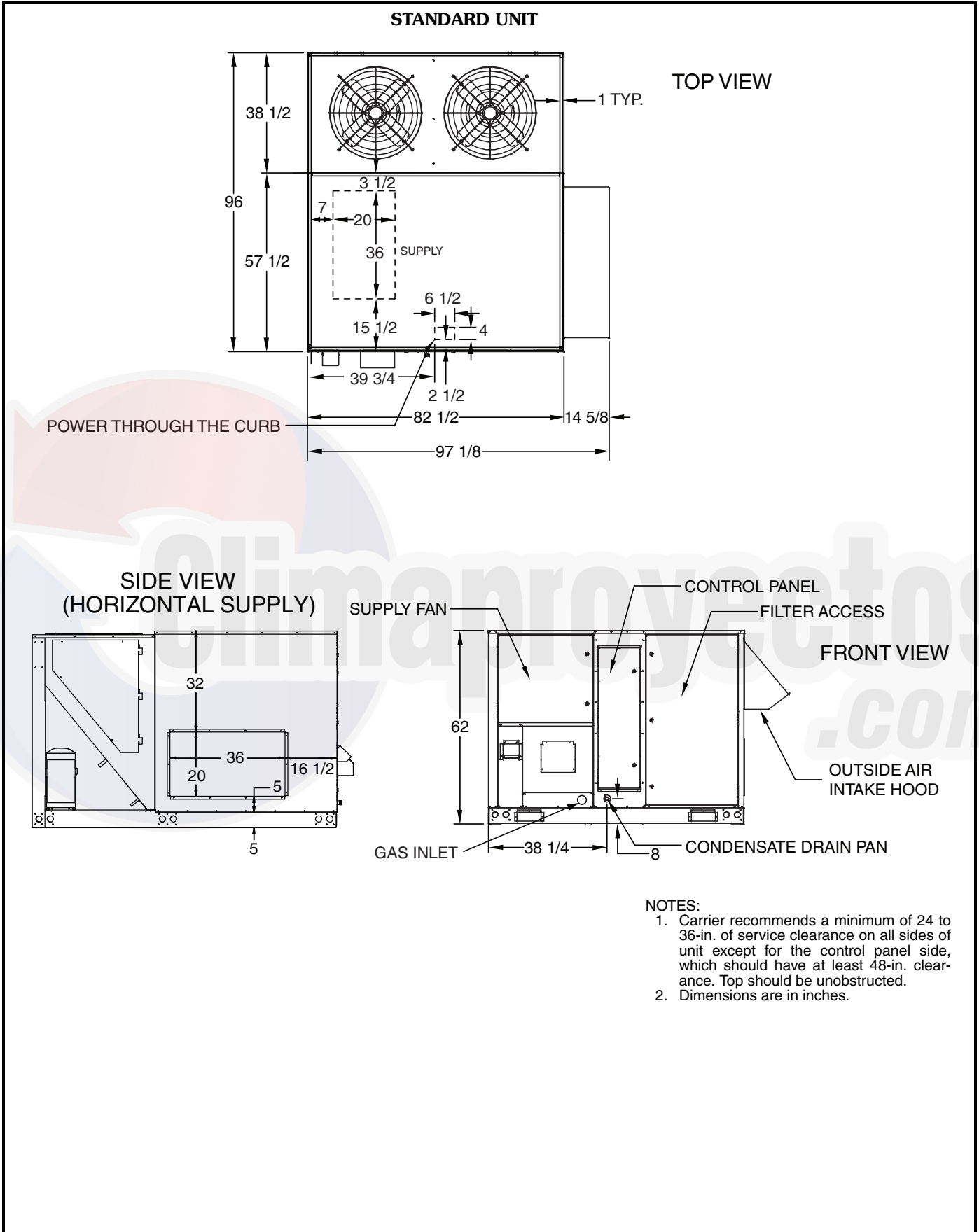

Base unit dimensions — 62DC,DD12-20



UNIT WITH OPTIONAL EXHAUST

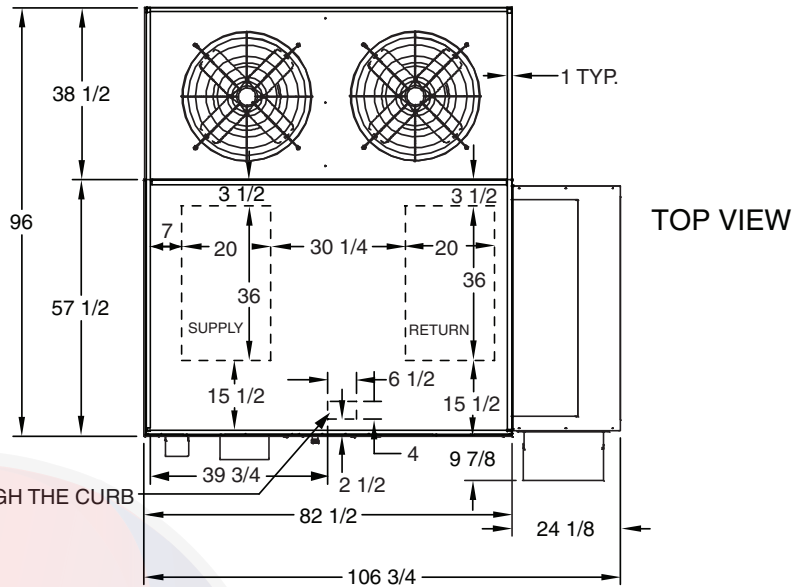

SIDE VIEW (HORIZONTAL SUPPLY)

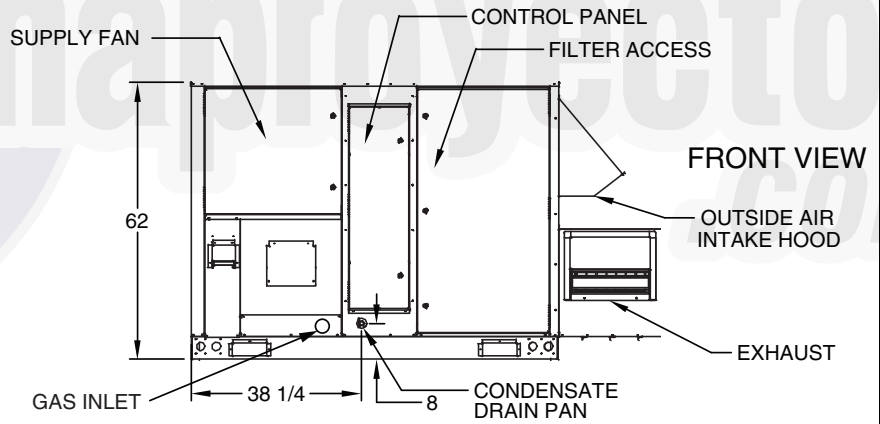
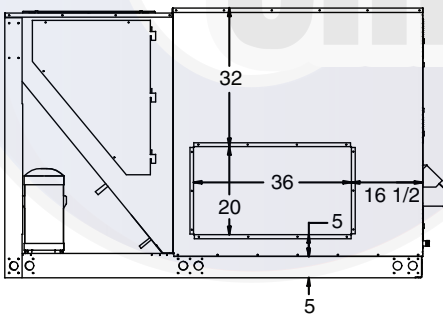

NOTES:

- Carrier recommends a minimum of 24 to 36-in. of service clearance on all sides of unit except for the control panel side, which should have at least 48-in. clearance. Top should be unobstructed.
- Dimensions are in inches.

UNIT WITH OPTIONAL ENERGY CONSERVATION WHEEL

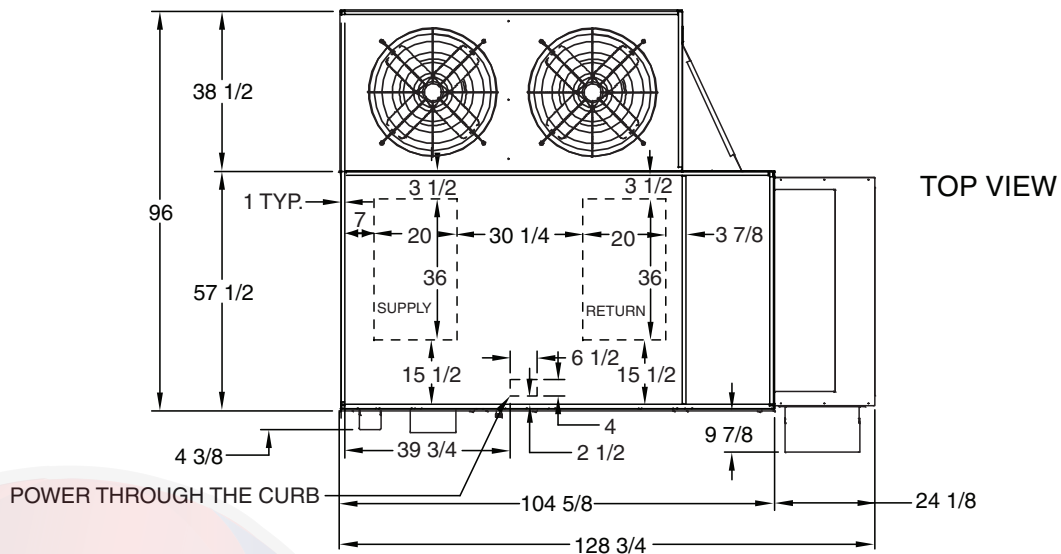

SIDE VIEW
(HORIZONTAL SUPPLY)

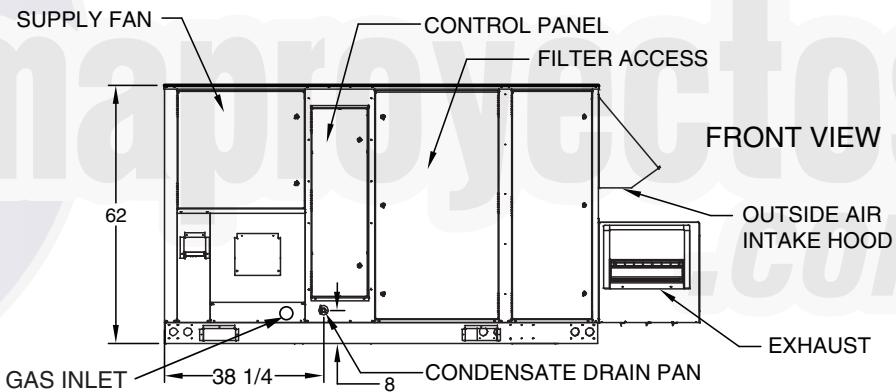
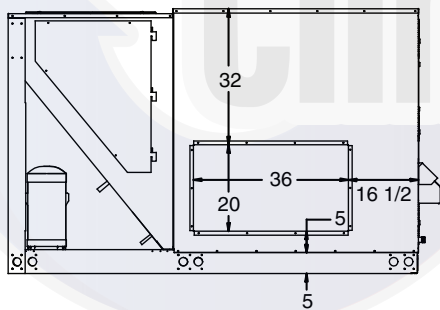

NOTES:

- Carrier recommends a minimum of 24 to 36-in. of service clearance on all sides of unit except for the control panel side, which should have at least 48-in. clearance. Top should be unobstructed.
- Dimensions are in inches.

Base unit dimensions — 62DA,DB22-38



STANDARD UNIT

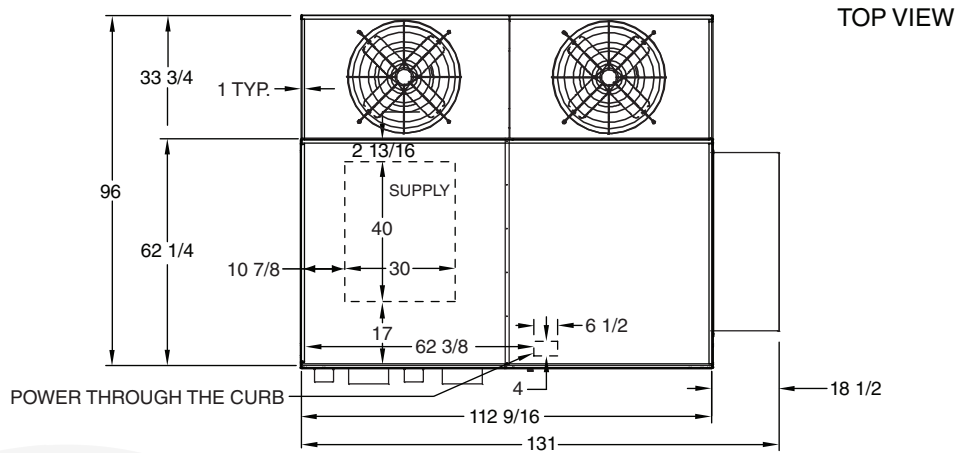

SIDE VIEW (HORIZONTAL SUPPLY)

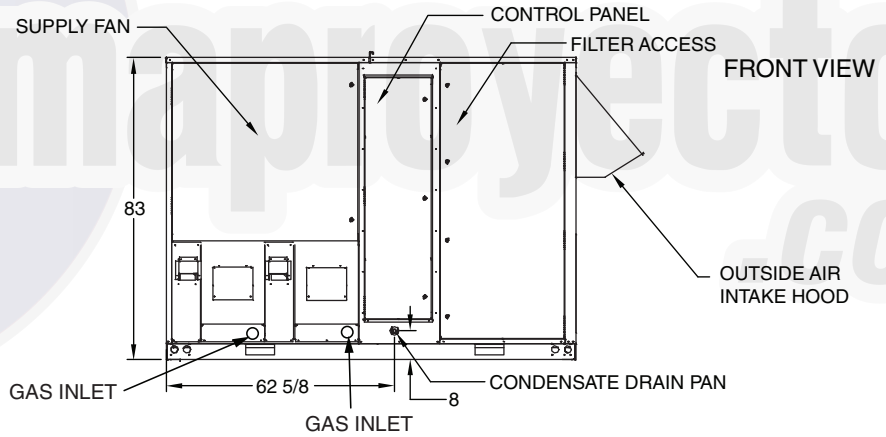
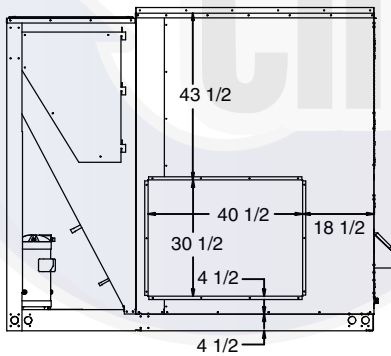

NOTES:

- Carrier recommends a minimum of 24 to 36-in. of service clearance on all sides of unit except for the control panel side, which should have at least 48-in. clearance. Top should be unobstructed.
- Dimensions are in inches.

Base unit dimensions — 62DC,DD22-38



UNIT WITH OPTIONAL EXHAUST

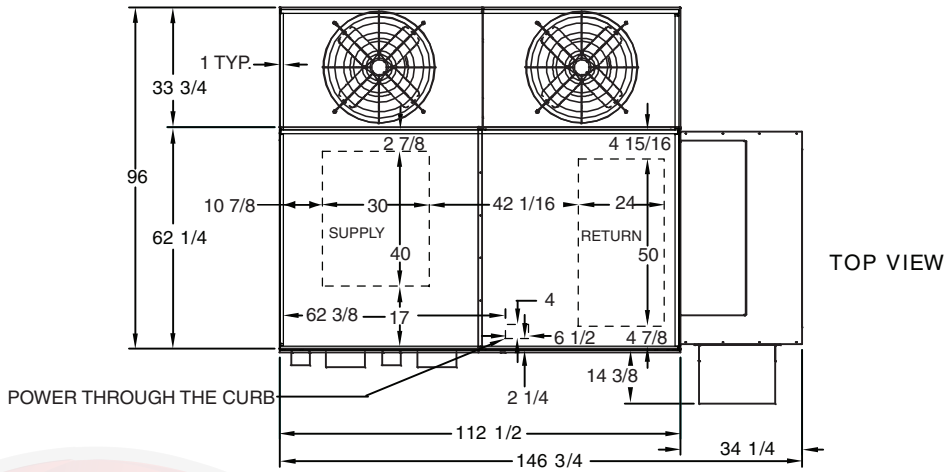

SIDE VIEW (HORIZONTAL SUPPLY)

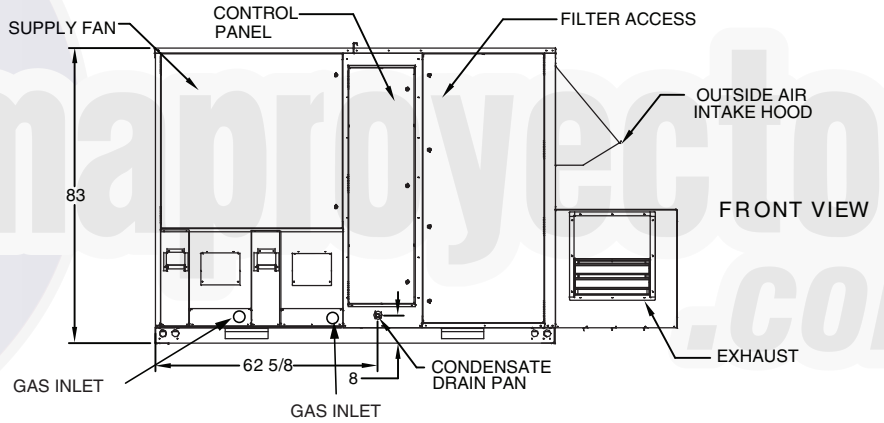
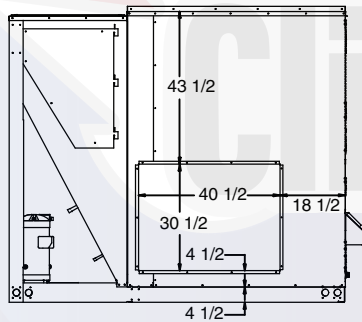

NOTES:

1. Carrier recommends a minimum of 24 to 36-in. of service clearance on all sides of unit except for the control panel side, which should have at least 48-in. clearance. Top should be unobstructed.
2. Dimensions are in inches.

Base unit dimensions — 62DC,DD22-38 (cont)



UNIT WITH OPTIONAL ENERGY CONSERVATION WHEEL

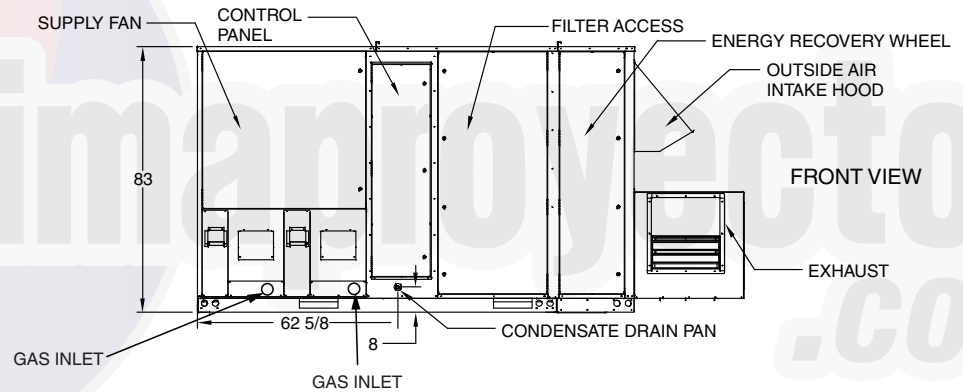
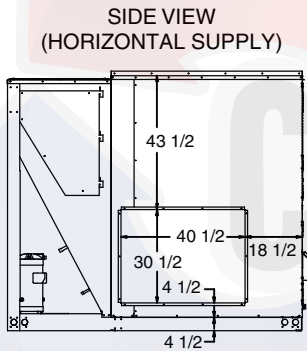
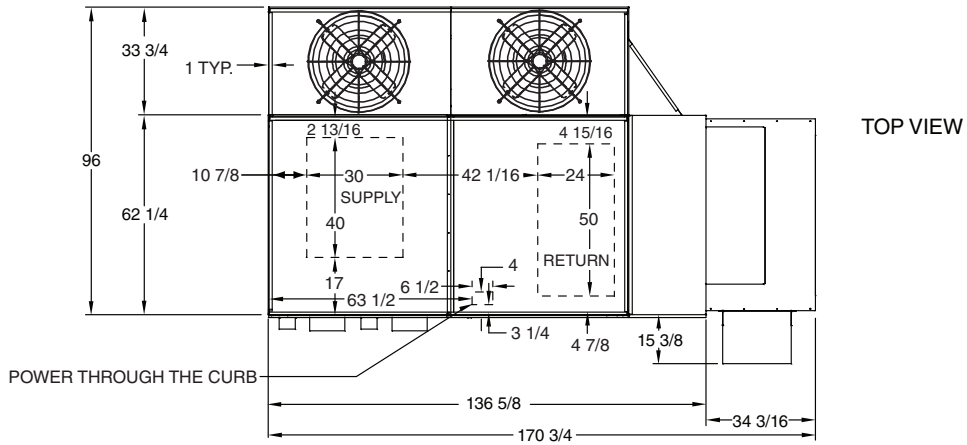

NOTES:

1. Carrier recommends a minimum of 24 to 36-in. of service clearance on all sides of unit except for the control panel side, which should have at least 48-in. clearance. Top should be unobstructed.
2. Dimensions are in inches.

Accessory dimensions

62DA,DB,DC,DD07-20

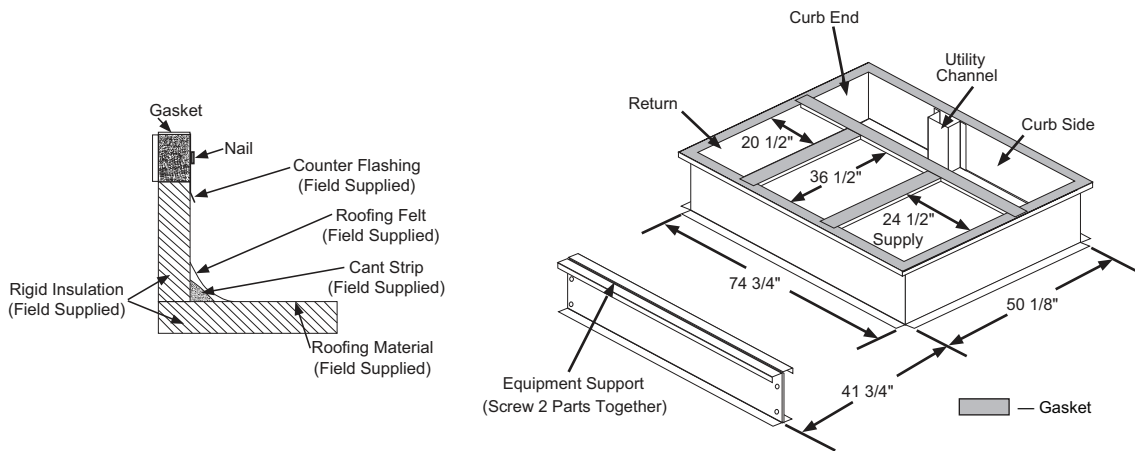

NOTES:

1. Dimensions are in inches.
2. Field-assembled curbs are shown. Factory-assembled curbs are also available.
3. Curbs are available in 14-in. and 24-in. heights.

62DA,DB,DC,DD22-38

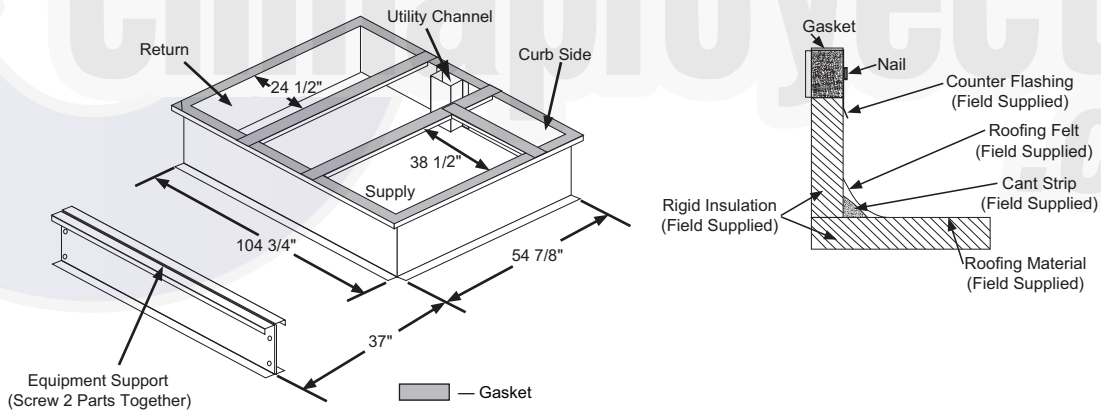

NOTES:

1. Dimensions are in inches.
2. Field-assembled curbs are shown. Factory-assembled curbs are also available.
3. Curbs are available in 14-in. and 24-in. heights.

Selection procedure

Refer to the Applied Rooftop Builder to select unit.

Performance data



COOLING CAPACITIES

62DA,DB07 AND 62DC,DD07 WITHOUT ECW

Entering Air Quantity (Cfm)		Temp (F) Air Entering (Edb)									
		80					90				
		Entering Air — Ewb (F)									
		70	74	75	76	78	70	74	75	76	78
700	TC	55,818	59,797	60,819	61,852	63,944	53,844	57,803	58,819	59,845	61,913
	SHC	28,835	25,326	24,422	23,551	21,691	35,572	32,221	31,370	30,499	28,697
	W	3,804	3,839	3,849	3,854	3,874	4,232	4,268	4,278	4,289	4,314
950	TC	61,617	65,773	66,844	67,907	70,055	59,230	63,318	64,369	65,439	67,570
	SHC	32,270	27,523	26,309	25,099	22,604	41,761	37,042	35,874	34,712	32,312
	W	3,954	3,992	4,003	4,014	4,037	4,383	4,431	4,443	4,456	4,482
1250	TC	65,784	69,992	71,066	72,140	74,278	63,010	67,163	68,225	69,296	71,445
	SHC	35,796	29,568	27,987	26,400	23,195	48,544	42,432	40,896	39,349	36,244
	W	4,111	4,157	4,169	4,181	4,206	4,542	4,595	4,608	4,623	4,652
1500	TC	67,946	72,192	73,256	74,326	76,440	65,023	69,218	70,273	71,336	73,442
	SHC	38,458	31,071	29,201	27,323	23,557	54,005	46,930	45,103	43,284	39,509
	W	4,231	4,200	4,292	4,305	4,331	4,666	4,714	4,729	4,744	4,776

62DA,DB07 AND 62DC,DD07 WITHOUT ECW (cont)

Entering Air Quantity (Cfm)		Temp (F) Air Entering (Edb)									
		100					105				
		Entering Air — Ewb (F)									
		70	74	75	76	78	70	74	75	76	78
700	TC	51,638	55,466	56,450	57,445	59,441	50,452	54,129	55,137	56,107	58,064
	SHC	42,199	38,929	38,084	37,231	35,431	45,437	42,134	41,397	40,547	38,818
	W	4,734	4,776	4,787	4,799	4,823	5,024	5,071	5,079	5,093	5,121
950	TC	56,503	60,414	61,423	62,449	64,573	56,353	58,845	59,800	60,796	62,807
	SHC	50,902	46,387	45,265	44,124	41,898	56,074	51,001	49,853	48,732	46,501
	W	4,892	4,941	4,955	4,969	4,995	5,208	5,240	5,255	5,270	5,300
1250	TC	61,484	63,876	64,930	65,927	67,862	62,799	62,405	63,255	64,058	66,077
	SHC	61,484	55,025	53,616	52,113	48,993	62,799	60,415	58,981	57,385	55,475
	W	5,089	5,110	5,127	5,136	5,173	5,436	5,415	5,430	5,450	5,474
1500	TC	65,431	65,806	66,728	67,776	69,628	66,819	66,977	67,018	66,077	67,780
	SHC	65,431	60,774	59,054	57,576	54,928	66,819	66,977	67,018	64,563	61,206
	W	5,232	5,235	5,253	5,265	5,302	5,594	5,592	5,590	5,586	5,602

62DC,DD07 WITH ECW

Entering Air Quantity (Cfm)		Temp (F) Air Entering (Edb)									
		75					85				
		Entering Air — Ewb (F)									
		57	62	67	72	75	57	62	67	72	75
1500	TC	51,900	56,500	61,400	66,100	68,900	58,400	58,500	61,800	66,800	69,900
	SHC	51,400	42,900	34,100	24,900	19,300	58,400	58,500	51,000	42,100	36,400
	W	4,701	4,734	4,783	4,836	4,869	4,756	4,757	4,785	4,839	4,882
1800	TC	55,300	58,200	63,100	67,700	70,500	61,900	62,000	63,300	68,500	71,600
	SHC	55,300	47,300	36,700	25,600	19,000	61,900	62,000	56,700	46,200	39,600
	W	4,840	4,861	4,916	4,970	5,004	4,900	4,901	4,922	4,976	5,020
2200	TC	58,300	59,500	64,400	69,100	71,700	65,200	65,300	65,000	69,800	73,000
	SHC	58,300	52,500	40,100	26,600	18,400	65,200	65,300	62,800	51,400	43,600
	W	5,017	5,030	5,074	5,139	5,174	5,089	5,090	5,085	5,150	5,192
2500	TC	59,900	60,200	65,000	69,700	72,300	67,200	67,300	67,400	70,400	73,700
	SHC	59,900	54,900	42,500	27,500	18,300	67,200	67,300	67,400	55,500	46,900
	W	5,147	5,147	5,198	5,258	5,293	5,226	5,227	5,228	5,272	5,313

LEGEND

- ECW — Energy Conservation Wheel
- Edb — Entering Dry Bulb
- Ewb — Entering Wet Bulb
- SHC — Sensible Heat Capacity (Btuh)
- TC — Total Capacity (Btuh) Gross
- W — Compressor Motor Power Input (W)

NOTES:

1. Direct interpolation is permissible. Do not extrapolate.
2. Cooling capacities are gross and do not include deduction for indoor fan motor heat.

COOLING CAPACITIES (cont)

62DA,DB AND 62DC,DD08 WITHOUT ECW

Entering Air Quantity (Cfm)		Temp (F) Air Entering (Edb)									
		80					90				
		Entering Air — Ewb (F)									
		70	74	75	76	78	70	74	75	76	78
800	TC	66,638	71,484	72,775	74,033	76,603	64,098	69,000	70,236	71,510	74,058
	SHC	34,460	30,404	28,409	28,355	26,330	41,968	38,234	37,256	36,252	34,223
	W	4,938	4,940	4,941	4,942	4,943	5,385	5,384	5,384	5,385	5,390
1150	TC	75,798	84,071	82,404	83,722	86,431	72,615	77,876	79,212	80,538	83,261
	SHC	39,543	33,931	32,469	30,947	27,998	50,861	45,476	44,059	42,651	39,771
	W	5,077	5,082	5,083	5,084	5,086	5,521	5,523	5,524	5,525	5,526
1450	TC	80,669	86,035	87,389	88,739	91,427	77,190	82,406	83,752	85,106	87,901
	SHC	43,262	36,138	34,300	32,450	28,715	58,044	50,911	49,127	47,330	43,909
	W	5,197	5,201	5,201	5,202	5,203	5,635	5,639	5,639	5,640	5,640
1800	TC	84,407	89,794	91,148	92,499	95,159	80,610	85,921	87,138	88,530	91,259
	SHC	47,247	38,349	36,111	33,856	29,320	65,907	57,295	54,838	52,708	48,315
	W	5,329	5,333	5,334	5,334	5,334	5,768	5,770	5,772	5,771	5,771

62DA,DB AND DC,DD08 WITHOUT ECW (cont)

Entering Air Quantity (Cfm)		Temp (F) Air Entering (Edb)									
		100					105				
		Entering Air — Ewb (F)									
		70	74	75	76	78	70	74	75	76	78
800	TC	61,364	66,088	67,307	68,595	71,108	59,845	64,573	65,766	66,998	69,466
	SHC	49,392	45,643	44,704	43,819	41,879	52,914	49,456	48,528	47,580	45,650
	W	5,895	5,899	5,899	5,900	5,900	6,193	6,192	6,194	6,196	6,200
1150	TC	69,217	74,102	75,416	76,692	79,328	68,694	72,108	73,447	74,595	77,272
	SHC	62,109	56,519	55,212	53,800	51,010	68,080	62,072	60,900	59,337	56,768
	W	6,038	6,042	6,042	6,044	6,046	6,338	6,342	6,343	6,347	6,345
1450	TC	73,339	78,207	79,495	80,947	83,415	75,812	76,128	77,420	78,573	81,155
	SHC	72,256	65,352	6,368	62,145	58,390	75,812	72,636	70,930	69,118	65,683
	W	6,154	6,158	6,158	6,159	6,163	6,465	6,466	6,468	6,468	6,447
1800	TC	80,418	81,541	82,624	83,979	86,392	82,352	82,563	82,636	81,841	82,922
	SHC	80,418	75,679	73,275	71,367	66,807	82,352	82,563	82,636	80,619	74,466
	W	6,292	6,291	6,293	6,293	6,297	6,578	6,573	6,578	6,572	6,579

62DC,DD08 WITH ECW

Entering Air Quantity (Cfm)		Temp (F) Air Entering (Edb)									
		75					85				
		Entering Air — Ewb (F)									
		57	62	67	72	75	57	62	67	72	75
1800	TC	61,600	67,110	72,900	77,560	82,100	69,700	69,900	73,450	79,550	83,300
	SHC	60,300	51,000	40,500	31,800	22,800	69,700	69,900	60,900	50,000	43,500
	W	5,994	5,999	6,004	6,010	6,015	6,002	6,005	6,008	6,013	6,015
2200	TC	66,300	69,100	75,000	79,700	84,200	74,200	74,350	75,600	81,780	85,500
	SHC	66,300	56,700	43,900	33,500	22,700	74,200	74,350	67,000	55,800	47,960
	W	6,144	6,147	6,153	6,158	6,163	6,150	6,151	6,154	6,160	6,164
2600	TC	69,200	70,700	76,500	81,000	85,400	77,500	77,660	77,300	82,970	86,830
	SHC	69,200	60,800	47,500	34,900	22,300	77,500	77,660	74,000	60,900	52,000
	W	6,293	6,294	6,300	6,306	6,311	6,300	6,305	6,307	6,309	6,312
3000	TC	71,300	71,500	77,370	81,800	86,200	80,100	80,190	80,300	84,100	87,675
	SHC	71,300	65,100	50,700	36,400	21,900	80,100	80,190	80,300	64,500	56,100
	W	6,442	6,445	6,448	6,453	6,458	6,450	6,452	6,454	6,455	6,460

LEGEND

ECW — Energy Conservation Wheel
Edb — Entering Dry Bulb
Ewb — Entering Wet Bulb
SHC — Sensible Heat Capacity (Btuh)
TC — Total Capacity (Btuh) Gross
W — Compressor Motor Power Input (W)

NOTES:

1. Direct interpolation is permissible. Do not extrapolate.
2. Cooling capacities are gross and do not include deduction for indoor fan motor heat.

Performance data (cont)



COOLING CAPACITIES (cont)

62DA,DB AND 62DC,DD09 WITHOUT ECW

Entering Air Quantity (Cfm)		Temp (F) Air Entering (Edb)									
		80					90				
		Entering Air — Ewb (F)									
		70	74	75	76	78	70	74	75	76	78
900	TC	75,277	80,741	82,146	83,552	86,430	72,682	78,051	79,429	80,808	83,646
	SHC	38,936	34,355	33,198	32,027	29,735	47,523	43,205	42,103	40,951	38,674
	W	5,647	5,728	5,749	5,770	5,811	6,208	6,292	6,313	6,336	6,383
1300	TC	85,683	91,515	92,985	94,493	97,490	82,172	87,987	89,430	90,899	93,842
	SHC	44,821	38,308	36,604	34,938	31,545	57,521	51,387	49,769	48,163	44,837
	W	5,962	6,053	6,078	6,102	6,152	6,526	6,622	6,648	6,674	6,728
1600	TC	90,591	96,479	97,988	99,497	102,482	86,594	92,502	93,977	95,462	95,446
	SHC	48,575	50,445	38,428	36,378	32,224	64,444	56,956	54,968	52,977	48,985
	W	6,159	6,260	6,284	6,310	6,361	6,725	6,824	6,851	6,878	6,933
2100	TC	95,723	101,757	103,249	104,741	107,603	91,258	97,211	98,518	100,177	103,148
	SHC	54,041	43,897	41,276	38,631	33,001	75,601	65,778	62,904	60,703	55,593
	W	6,444	6,544	6,570	6,597	6,653	7,004	7,109	7,142	7,165	7,222

62DA,DB AND 62DC,DD09 WITHOUT ECW (cont)

Entering Air Quantity (Cfm)		Temp (F) Air Entering (Edb)									
		100					105				
		Entering Air — Ewb (F)									
		70	74	75	76	78	70	74	75	76	78
900	TC	69,743	74,852	76,182	77,535	80,281	68,071	73,110	74,405	75,693	78,431
	SHC	55,953	51,576	50,510	49,444	47,235	60,006	55,840	54,782	53,678	51,478
	W	6,861	6,957	6,981	7,006	7,057	7,238	7,341	7,369	7,396	7,437
1300	TC	78,432	83,740	85,061	86,559	89,362	76,359	81,686	83,051	84,360	87,352
	SHC	70,210	64,017	62,334	60,923	57,510	76,282	70,396	68,855	67,122	64,178
	W	7,192	7,295	7,327	7,352	7,404	7,577	7,639	7,666	7,695	7,730
1600	TC	82,513	87,827	89,036	90,600	93,536	83,387	85,668	87,220	88,566	91,126
	SHC	80,472	72,902	70,614	68,866	64,948	83,387	80,687	79,054	77,051	72,996
	W	7,392	7,489	7,525	7,536	7,584	7,788	7,837	7,848	7,868	7,918
2100	TC	91,872	92,242	93,530	94,186	98,193	94,128	94,365	94,428	94,479	95,494
	SHC	91,872	87,061	84,468	80,876	77,380	94,128	94,365	94,428	93,616	87,945
	W	7,765	7,765	7,791	7,830	7,842	8,178	8,176	8,175	8,163	8,195

62DC,DD09 WITH ECW

Entering Air Quantity (Cfm)		Temp (F) Air Entering (Edb)									
		75					85				
		Entering Air — Ewb (F)									
		57	62	67	72	75	57	62	67	72	75
2100	TC	71,000	77,000	83,500	89,900	93,700	80,300	80,500	83,900	90,900	95,100
	SHC	69,600	59,000	46,900	33,800	26,000	80,300	80,500	70,100	57,900	50,300
	W	6,857	6,939	7,025	7,129	7,186	6,985	6,987	7,038	7,137	7,203
2550	TC	76,100	78,900	85,600	92,000	95,700	85,000	85,200	86,500	93,000	97,200
	SHC	76,100	65,200	50,400	35,200	25,500	85,000	85,200	77,100	63,900	54,700
	W	7,097	7,137	7,234	7,329	7,393	7,227	7,229	7,242	7,347	7,417
3050	TC	79,400	80,600	87,100	93,500	97,000	88,900	89,000	88,200	94,400	98,700
	SHC	79,400	69,600	54,700	36,400	24,800	88,900	89,000	85,000	68,300	59,800
	W	7,339	7,353	7,442	7,543	7,609	7,473	7,475	7,460	7,566	7,631
3500	TC	81,600	81,500	87,900	94,300	97,800	91,500	91,600	91,700	95,400	99,400
	SHC	81,600	74,500	58,200	37,500	24,500	91,500	91,600	91,700	73,400	64,200
	W	7,543	7,538	7,629	7,729	7,788	7,687	7,689	7,691	7,754	7,822

LEGEND

- ECW — Energy Conservation Wheel
- Edb — Entering Dry Bulb
- Ewb — Entering Wet Bulb
- SHC — Sensible Heat Capacity (Btuh)
- TC — Total Capacity (Btuh) Gross
- W — Compressor Motor Power Input (W)

NOTES:

1. Direct interpolation is permissible. Do not extrapolate.
2. Cooling capacities are gross and do not include deduction for indoor fan motor heat.

COOLING CAPACITIES (cont)

62DA,DB AND 62DC,DD12 WITHOUT ECW

Entering Air Quantity (Cfm)		Temp (F) Air Entering (Edb)									
		80					90				
		Entering Air — Ewb (F)									
		70	74	75	76	78	70	74	75	76	78
1100	TC	90,454	97,036	98,722	100,390	103,884	88,900	95,600	97,300	99,100	102,700
	SHC	46,780	41,236	39,836	38,360	35,608	58,800	53,600	52,300	50,900	48,200
	W	6,608	6,650	6,654	6,660	6,634	6,834	6,866	6,868	6,874	6,882
1500	TC	100,820	107,830	109,622	111,420	115,014	99,500	106,700	108,500	110,300	114,100
	SHC	52,532	45,188	43,268	41,334	37,426	69,600	62,500	60,600	58,800	55,100
	W	6,814	6,788	6,786	6,784	6,776	6,886	6,902	6,904	6,906	6,906
1800	TC	106,066	113,232	115,040	116,860	120,484	104,834	112,200	114,000	115,900	119,700
	SHC	56,340	47,518	45,242	42,938	38,258	77,100	68,500	66,300	64,100	59,700
	W	6,930	6,896	6,890	6,886	6,872	6,884	6,886	6,884	6,908	6,904
2200	TC	110,966	118,226	120,040	121,870	125,478	110,000	117,400	119,300	121,100	124,900
	SHC	60,898	50,124	47,358	44,592	39,028	86,500	76,200	73,500	70,800	65,500
	W	7,056	7,040	7,034	7,028	7,010	6,888	6,888	6,884	6,882	6,874

62DA,DB AND 62DC,DD12 WITHOUT ECW (cont)

Entering Air Quantity (Cfm)		Temp (F) Air Entering (Edb)									
		100					105				
		Entering Air — Ewb (F)									
		70	74	75	76	78	70	74	75	76	78
1100	TC	85,300	91,700	93,600	95,300	98,800	83,600	89,700	91,400	93,100	96,600
	SHC	69,200	64,000	62,800	61,456	58,800	74,400	69,100	67,800	66,600	64,000
	W	7,630	7,664	7,692	7,696	7,720	8,060	8,110	8,118	8,128	8,166
1500	TC	95,000	101,800	103,600	105,400	108,900	92,800	99,300	101,000	102,700	106,300
	SHC	84,000	77,000	75,300	73,500	69,800	90,900	84,100	82,504	80,700	77,200
	W	7,704	7,720	7,726	7,732	7,748	8,148	8,172	8,180	8,188	8,202
1800	TC	100,000	106,800	108,600	110,400	114,014	100,600	104,000	105,700	107,500	110,900
	SHC	94,400	86,300	84,200	82,000	77,700	100,600	94,800	92,600	90,900	86,600
	W	7,714	7,744	7,748	7,754	7,762	8,202	8,198	8,208	8,210	8,230
2200	TC	106,500	111,500	113,400	115,200	118,800	109,100	109,100	110,300	111,900	115,600
	SHC	106,500	97,700	95,800	93,200	88,000	109,100	109,100	105,900	103,400	99,100
	W	7,768	7,766	7,764	7,766	7,772	8,250	8,238	8,232	8,238	8,242

62DC,DD12 WITH ECW

Entering Air Quantity (Cfm)		Temp (F) Air Entering (Edb)									
		75					85				
		Entering Air — Ewb (F)									
		57	62	67	72	75	57	62	67	72	75
2200	TC	82,400	89,900	97,800	105,700	110,300	91,500	90,500	98,300	106,800	111,900
	SHC	78,700	66,300	53,400	39,900	31,500	91,500	89,300	78,000	65,100	56,900
	W	8,066	8,114	8,152	8,190	8,208	8,126	8,128	8,152	8,188	8,208
2600	TC	86,700	92,500	100,600	108,400	113,000	96,800	97,000	102,300	109,700	114,700
	SHC	87,400	71,800	56,900	41,000	31,300	96,800	97,000	86,000	70,700	60,900
	W	8,246	8,290	8,310	8,348	8,362	8,308	8,310	8,324	8,358	8,380
3200	TC	91,900	95,200	103,200	111,100	115,500	102,900	103,100	104,200	112,300	117,500
	SHC	91,900	80,200	61,500	42,600	30,700	102,900	103,100	95,500	78,500	67,100
	W	8,504	8,524	8,568	8,576	8,588	8,548	8,548	8,560	8,594	8,604
3700	TC	95,100	96,800	104,800	112,600	116,800	106,700	106,900	106,000	113,900	118,900
	SHC	95,100	84,900	66,100	43,900	30,200	106,700	106,900	103,800	85,800	72,100
	W	8,710	8,7123	8,748	8,762	8,780	8,746	8,748	8,752	8,776	8,788

LEGEND

ECW — Energy Conservation Wheel
Edb — Entering Dry Bulb
Ewb — Entering Wet Bulb
SHC — Sensible Heat Capacity (Btuh)
TC — Total Capacity (Btuh) Gross
W — Compressor Motor Power Input (W)

NOTES:

1. Direct interpolation is permissible. Do not extrapolate.
2. Cooling capacities are gross and do not include deduction for indoor fan motor heat.

Performance data (cont)



COOLING CAPACITIES (cont)

62DA,DB AND 62DC,DD14 WITHOUT ECW

Entering Air Quantity (Cfm)		Temp (F) Air Entering (Edb)									
		80					90				
		Entering Air — Ewb (F)									
		70	74	75	76	78	70	74	75	76	78
1350	TC	108,528	116,324	118,318	120,324	124,376	107,000	115,000	117,000	119,200	123,400
	SHC	56,096	49,220	47,480	45,742	42,308	71,100	64,700	63,100	61,400	58,000
	W	7,968	8,078	8,100	8,124	8,134	8,168	8,260	8,282	8,304	8,348
1900	TC	121,478	129,662	131,732	133,808	137,972	120,300	128,800	130,900	133,100	130,700
	SHC	63,652	54,280	51,844	49,420	44,412	85,600	76,500	74,200	71,800	62,300
	W	8,354	8,420	8,446	8,472	8,526	8,326	8,420	8,446	8,472	8,438
2400	TC	128,634	136,922	138,994	141,080	145,232	127,900	136,400	138,600	140,800	145,200
	SHC	69,568	57,810	54,656	51,594	45,412	97,700	86,300	83,300	80,400	74,400
	W	8,636	8,712	8,750	8,778	8,836	8,416	8,520	8,548	8,576	8,634
2900	TC	133,296	141,612	143,696	145,752	149,854	133,100	141,600	143,800	146,000	150,400
	SHC	75,052	60,720	57,122	53,454	46,122	109,000	95,600	92,100	88,600	81,500
	W	8,868	8,984	9,012	9,042	9,102	8,460	8,570	8,620	8,648	8,692

62DA,DB AND 62DC,DD14 WITHOUT ECW (cont)

Entering Air Quantity (Cfm)		Temp (F) Air Entering (Edb)									
		100					105				
		Entering Air — Ewb (F)									
		70	74	75	76	78	70	74	75	76	78
1350	TC	102,700	110,500	112,500	114,500	118,700	100,600	108,000	110,000	111,900	116,100
	SHC	84,000	77,500	76,000	74,400	71,100	90,000	83,830	82,300	80,700	77,500
	W	9,156	9,256	9,278	9,300	9,350	9,734	9,788	9,810	9,832	9,902
1900	TC	115,000	123,000	125,100	127,200	125,400	113,000	120,000	122,000	124,100	122,500
	SHC	103,800	95,200	92,900	90,700	78,100	113,000	104,200	102,200	100,000	85,800
	W	9,316	9,412	9,440	9,464	9,436	9,878	9,940	9,966	9,988	9,988
2400	TC	122,200	123,000	132,000	134,100	138,400	125,000	127,000	128,790	130,900	135,000
	SHC	120,800	95,200	107,000	104,600	98,900	125,000	121,700	118,800	116,300	111,100
	W	9,388	9,412	9,520	9,550	9,598	10,182	10,062	10,064	10,086	10,144
2900	TC	131,200	130,100	136,800	138,800	143,200	134,300	134,500	134,400	135,800	139,400
	SHC	131,200	124,000	120,700	117,344	111,600	134,300	134,500	134,400	132,100	125,100
	W	9,532	9,564	9,592	9,620	9,672	10,182	10,176	10,172	10,194	10,228

62DC,DD14 WITH ECW

Entering Air Quantity (Cfm)		Temp (F) Air Entering (Edb)									
		75					85				
		Entering Air — Ewb (F)									
		57	62	67	72	75	57	62	67	72	75
2900	TC	100,000	108,600	117,800	126,800	132,000	112,500	112,700	118,600	128,200	134,100
	SHC	97,400	82,700	65,500	47,800	36,900	112,500	112,700	98,100	80,900	70,100
	W	9,806	9,910	10,002	10,130	10,210	9,958	9,962	10,004	10,142	10,280
3400	TC	105,800	111,300	120,600	129,400	134,600	118,100	118,300	121,300	130,800	136,900
	SHC	105,800	90,000	69,800	49,000	36,400	118,100	118,300	105,300	87,500	75,600
	W	10,064	10,096	10,230	10,364	10,444	10,224	10,228	10,256	10,396	10,472
4000	TC	110,200	113,500	122,700	131,500	136,600	123,200	123,400	123,500	133,200	139,100
	SHC	110,200	95,700	75,000	50,300	35,500	123,200	123,400	115,200	96,100	81,800
	W	10,348	10,368	10,478	10,630	10,710	10,494	10,496	10,536	10,652	10,748
4600	TC	113,700	115,100	123,900	133,000	137,800	127,300	127,500	127,600	134,600	140,300
	SHC	113,700	102,700	79,200	52,100	35,100	127,300	127,500	127,600	100,800	87,300
	W	10,622	10,600	10,754	10,884	10,964	10,818	10,822	10,790	10,906	11,016

LEGEND

- ECW — Energy Conservation Wheel
- Edb — Entering Dry Bulb
- Ewb — Entering Wet Bulb
- SHC — Sensible Heat Capacity (Btuh)
- TC — Total Capacity (Btuh) Gross
- W — Compressor Motor Power Input (W)

NOTES:

1. Direct interpolation is permissible. Do not extrapolate.
2. Cooling capacities are gross and do not include deduction for indoor fan motor heat.

COOLING CAPACITIES (cont)

62DA,DB AND 62DC,DD15 WITHOUT ECW

Entering Air Quantity (Cfm)		Temp (F) Air Entering (Edb)									
		80					90				
		Entering Air — Ewb (F)									
		70	74	75	76	78	70	74	75	76	78
1700	TC	143,266	153,674	156,344	159,044	164,492	138,266	148,622	151,302	153,942	159,416
	SHC	74,148	65,570	63,386	61,190	56,768	90,276	82,200	80,148	77,978	73,726
	W	10,586	10,642	10,656	10,670	10,692	11,614	11,674	11,690	11,706	11,744
2300	TC	159,700	170,712	173,526	176,346	182,002	153,630	164,462	167,246	170,050	175,736
	SHC	82,970	71,594	68,624	65,618	59,576	105,704	94,416	91,558	88,692	82,920
	W	10,908	10,966	10,382	11,000	11,036	11,952	12,026	12,046	12,066	12,110
3000	TC	171,770	183,030	185,884	188,742	194,404	164,736	175,714	178,574	181,434	187,278
	SHC	91,766	76,830	73,028	69,180	61,366	122,206	107,332	103,636	99,910	92,716
	W	11,246	11,318	11,336	11,354	11,392	12,296	12,382	12,404	12,428	12,476
3600	TC	178,510	189,884	192,726	195,574	201,220	170,808	182,134	184,962	187,806	193,446
	SHC	98,392	80,670	76,132	71,586	62,468	135,306	118,372	113,944	109,448	100,392
	W	11,518	11,594	11,612	11,632	11,672	12,574	12,654	12,678	12,704	12,756

62DA,DB AND 62DC,DD15 WITHOUT ECW (cont)

Entering Air Quantity (Cfm)		Temp (F) Air Entering (Edb)									
		100					105				
		Entering Air — Ewb (F)									
		70	74	75	76	78	70	74	75	76	78
1700	TC	132,748	142,674	145,272	147,952	153,254	129,742	139,516	142,038	144,644	149,820
	SHC	106,130	98,058	96,054	94,078	89,914	113,922	106,102	104,120	102,094	97,922
	W	12,822	12,878	12,896	12,916	12,958	13,496	13,572	13,594	13,618	13,666
2300	TC	146,660	157,156	160,020	162,708	168,190	143,026	153,080	155,890	158,598	163,868
	SHC	127,572	116,796	114,376	111,580	105,910	138,584	127,748	125,376	122,698	116,680
	W	13,160	13,246	13,264	13,288	13,340	13,854	13,946	13,958	13,970	14,014
3000	TC	157,084	167,238	170,138	172,826	178,334	161,024	162,950	165,880	168,646	173,954
	SHC	151,924	137,316	134,066	130,440	123,156	161,024	152,134	149,054	145,544	138,030
	W	13,510	13,614	13,634	13,662	13,708	14,282	14,276	14,276	14,288	14,338
3600	TC	168,538	172,766	175,394	178,136	184,096	172,716	173,310	171,632	174,296	179,268
	SHC	168,538	154,380	150,082	145,782	137,794	172,716	173,310	168,756	164,730	155,740
	W	13,848	13,904	13,930	13,954	13,972	14,552	14,672	14,554	14,540	14,582

62DC,DD15 WITH ECW

Entering Air Quantity (Cfm)		Temp (F) Air Entering (Edb)									
		75					85				
		Entering Air — Ewb (F)									
		57	62	67	72	75	57	62	67	72	75
3600	TC	130,800	142,300	154,600	166,800	174,100	146,200	143,900	155,300	168,800	176,700
	SHC	123,900	105,900	85,100	62,800	49,300	146,200	142,400	124,900	104,100	90,800
	W	12,726	12,760	12,806	12,878	12,916	12,772	12,770	12,818	12,880	12,926
4300	TC	138,400	146,200	158,800	171,000	178,200	154,600	154,900	159,900	172,800	180,900
	SHC	138,400	113,200	91,000	64,500	48,700	154,600	154,900	135,100	113,200	98,200
	W	13,894	13,036	13,086	13,162	13,202	13,070	13,070	13,100	13,166	13,214
5300	TC	145,900	150,000	162,600	174,700	181,700	163,400	163,600	164,300	176,800	184,600
	SHC	145,900	124,800	99,400	67,300	47,400	163,400	163,600	151,600	123,400	107,900
	W	13,398	13,422	13,476	13,548	13,598	13,480	13,482	13,486	13,558	13,616
5800	TC	148,800	151,400	163,700	175,900	182,800	166,800	167,100	166,000	177,800	186,800
	SHC	148,800	130,200	102,800	68,500	46,700	166,800	167,100	159,100	128,200	113,400
	W	13,596	13,614	13,676	13,742	13,972	13,686	13,686	13,682	13,760	13,798

LEGEND

ECW — Energy Conservation Wheel
Edb — Entering Dry Bulb
Ewb — Entering Wet Bulb
SHC — Sensible Heat Capacity (Btuh)
TC — Total Capacity (Btuh) Gross
W — Compressor Motor Power Input (W)

NOTES:

1. Direct interpolation is permissible. Do not extrapolate.
2. Cooling capacities are gross and do not include deduction for indoor fan motor heat.

Performance data (cont)



COOLING CAPACITIES (cont)

62DA,DB AND 62DC,DD16 WITHOUT ECW

Entering Air Quantity (Cfm)		Temp (F) Air Entering (Edb)									
		80					90				
		Entering Air — Ewb (F)									
		70	74	75	76	78	70	74	75	76	78
2000	TC	169,556	181,388	184,424	187,498	193,720	163,804	175,464	178,522	181,562	187,730
	SHC	87,768	77,376	74,750	72,084	66,720	106,814	97,000	94,496	91,944	86,810
	W	12,992	13,208	13,262	13,318	13,432	14,282	14,504	14,566	14,626	14,752
2800	TC	190,150	202,652	205,824	209,010	215,402	182,966	195,242	198,448	201,624	207,918
	SHC	98,920	84,886	81,214	77,524	70,076	126,820	112,886	109,532	105,976	98,530
	W	13,694	13,926	13,988	14,052	14,184	15,002	15,254	15,332	15,402	15,546
3600	TC	202,660	215,344	218,538	221,732	228,100	194,480	207,002	210,172	213,386	219,944
	SHC	108,520	90,540	85,910	81,234	71,794	145,302	127,684	123,172	118,646	109,644
	W	14,256	14,512	14,578	14,644	14,782	15,566	15,850	15,924	16,000	16,130
4400	TC	210,622	223,318	226,486	229,662	235,966	201,572	214,044	217,362	220,994	227,520
	SHC	117,140	95,234	89,652	84,078	72,880	162,510	140,986	135,650	131,038	119,818
	W	14,742	15,010	15,078	15,146	15,286	16,050	16,358	16,426	16,454	16,594

62DA,DB AND 62DC,DD16 WITHOUT ECW (cont)

Entering Air Quantity (Cfm)		Temp (F) Air Entering (Edb)									
		100					105				
		Entering Air — Ewb (F)									
		70	74	75	76	78	70	74	75	76	78
2000	TC	157,270	168,566	171,402	174,398	180,526	153,580	165,058	168,008	171,000	177,118
	SHC	125,464	115,836	113,218	110,840	105,870	134,554	125,304	122,912	120,526	115,618
	W	15,824	16,080	16,134	16,204	16,324	16,714	16,904	16,956	17,010	17,118
2800	TC	174,716	186,704	189,920	193,148	199,628	170,876	182,942	186,006	188,816	195,568
	SHC	153,932	140,132	136,846	133,560	126,628	167,188	154,428	151,106	147,228	141,022
	W	16,560	16,794	16,846	16,900	17,020	17,378	17,548	17,604	17,684	17,778
3600	TC	185,646	197,742	200,894	204,122	211,014	191,952	193,888	196,412	199,534	205,946
	SHC	180,720	163,598	159,246	154,928	146,834	191,952	182,420	177,462	173,156	164,556
	W	17,092	17,312	17,370	17,444	17,526	18,090	18,074	18,148	18,208	18,350
4400	TC	201,470	204,902	208,110	211,166	217,556	206,798	207,318	207,454	206,772	213,052
	SHC	201,470	186,420	181,374	175,950	165,386	206,798	207,318	205,504	198,900	188,756
	W	17,720	17,768	17,838	17,886	18,012	18,706	18,700	18,700	18,688	18,788

62DC,DD16 WITH ECW

Entering Air Quantity (Cfm)		Temp (F) Air Entering (Edb)									
		75					85				
		Entering Air — Ewb (F)									
		57	62	67	72	75	57	62	67	72	75
4400	TC	161,200	175,000	189,200	203,800	212,200	179,400	179,800	190,400	205,800	215,400
	SHC	155,200	130,000	103,700	76,756	60,000	179,400	180,600	153,400	126,700	110,800
	W	15,616	15,850	16,096	16,372	16,540	15,926	15,384	16,112	16,426	16,606
5100	TC	169,100	179,200	193,500	208,000	216,400	188,000	188,300	194,900	210,100	219,700
	SHC	171,000	140,100	109,500	78,400	59,400	188,000	188,300	167,200	136,100	117,800
	W	16,008	16,196	16,448	16,734	16,900	16,354	16,360	16,456	16,788	16,982
5800	TC	175,100	182,300	196,600	211,100	219,300	195,000	195,400	198,000	213,700	222,800
	SHC	175,100	149,500	115,500	80,000	58,500	195,000	195,400	176,300	146,500	124,700
	W	16,390	16,522	16,776	17,070	17,238	16,756	16,762	16,816	17,108	17,324
6500	TC	180,100	184,500	199,100	213,400	221,300	200,900	201,200	200,900	215,500	225,100
	SHC	180,100	159,600	121,500	82,200	57,300	200,900	201,200	188,800	155,000	131,700
	W	16,750	16,816	17,086	17,386	17,560	17,124	17,130	17,144	17,444	17,646

LEGEND

- ECW — Energy Conservation Wheel
- Edb — Entering Dry Bulb
- Ewb — Entering Wet Bulb
- SHC — Sensible Heat Capacity (Btuh)
- TC — Total Capacity (Btuh) Gross
- W — Compressor Motor Power Input (W)

NOTES:

1. Direct interpolation is permissible. Do not extrapolate.
2. Cooling capacities are gross and do not include deduction for indoor fan motor heat.

COOLING CAPACITIES (cont)

62DA,DB AND 62DC,DD20 WITHOUT ECW

Entering Air Quantity (Cfm)		Temp (F) Air Entering (Edb)									
		80					90				
		Entering Air — Ewb (F)									
		70	74	75	76	78	70	74	75	76	78
2400	TC	189,252	202,584	206,012	209,458	216,428	182,674	195,758	199,098	202,472	209,290
	SHC	97,788	85,516	82,410	79,310	73,112	121,016	109,364	106,406	103,370	97,152
	W	14,588	14,816	14,874	14,932	15,042	16,008	16,258	16,322	16,388	16,520
3100	TC	205,842	219,612	223,172	226,704	233,730	197,936	211,322	214,810	218,354	225,538
	SHC	107,298	91,654	87,928	83,904	75,720	138,366	122,936	119,288	115,496	107,636
	W	15,156	15,388	15,446	15,506	15,626	16,602	16,858	16,934	16,980	17,076
3700	TC	215,634	229,604	233,114	236,626	243,636	206,822	220,622	224,194	227,784	235,016
	SHC	114,668	96,340	91,604	86,804	77,076	152,270	134,386	129,814	125,194	115,904
	W	15,562	15,800	15,860	15,920	16,040	17,018	17,248	17,296	17,344	17,438
4400	TC	223,766	237,742	241,230	244,708	251,788	213,794	228,020	231,596	235,222	242,454
	SHC	122,500	100,818	95,218	89,598	78,338	167,194	146,068	140,662	135,278	124,452
	W	15,978	16,222	16,282	16,340	16,452	17,454	17,658	17,706	17,752	17,830

62DA,DB AND 62DC,DD20 WITHOUT ECW (cont)

Entering Air Quantity (Cfm)		Temp (F) Air Entering (Edb)									
		100					105				
		Entering Air — Ewb (F)									
		70	74	75	76	78	70	74	75	76	78
2400	TC	175,048	187,956	191,262	194,604	201,304	171,206	183,802	187,070	190,352	197,256
	SHC	143,742	132,514	129,608	126,648	120,448	154,662	143,556	140,722	137,840	132,422
	W	17,702	17,902	17,954	18,006	18,106	18,560	18,764	18,814	18,864	18,940
3100	TC	189,298	202,512	205,638	209,142	216,076	185,040	197,974	201,238	204,492	211,332
	SHC	168,618	153,882	149,676	146,008	138,294	183,332	169,148	165,466	161,662	154,198
	W	18,204	18,408	18,480	18,528	18,632	19,054	19,240	19,292	19,346	19,444
3700	TC	197,904	210,598	213,948	217,406	224,400	202,648	205,780	208,894	212,602	218,826
	SHC	189,098	170,978	166,466	161,988	152,916	202,648	189,496	185,012	181,138	171,516
	W	18,580	18,792	18,842	18,890	19,006	19,614	19,632	19,678	19,708	19,846
4400	TC	211,252	217,504	221,100	224,250	231,112	216,396	216,962	216,250	218,976	225,692
	SHC	211,252	190,910	186,060	180,416	169,902	216,396	215,196	208,848	202,902	192,812
	W	19,100	19,194	19,200	19,266	19,356	20,108	20,098	20,042	20,128	20,214

62DC,DD20 WITH ECW

Entering Air Quantity (Cfm)		Temp (F) Air Entering (Edb)									
		75					85				
		Entering Air — Ewb (F)									
		57	62	67	72	75	57	62	67	72	75
4400	TC	170,300	185,200	200,900	216,800	226,100	188,100	186,600	202,100	219,000	229,400
	SHC	159,800	135,100	108,700	81,900	65,000	188,100	181,800	158,000	131,600	115,800
	W	16,982	17,200	17,476	17,702	17,848	17,268	17,220	17,494	17,750	17,912
5100	TC	175,600	190,300	206,200	221,900	231,000	197,800	198,200	207,600	224,400	234,500
	SHC	171,400	145,400	115,200	83,500	64,400	197,800	198,200	172,200	141,800	122,600
	W	17,336	17,550	17,814	18,068	18,208	17,690	17,696	17,834	18,096	18,264
5800	TC	184,500	193,900	210,000	225,600	234,500	205,800	206,200	211,600	228,300	238,400
	SHC	184,500	155,000	121,100	85,100	63,600	205,800	206,200	186,000	151,700	130,400
	W	17,750	17,890	18,144	18,398	18,536	18,088	18,094	18,164	18,428	18,584
6500	TC	190,200	196,900	212,700	228,400	237,100	212,400	212,800	214,700	231,200	241,400
	SHC	190,200	165,000	126,500	87,400	62,700	212,400	212,800	194,700	161,200	137,900
	W	18,106	18,188	18,454	18,706	18,846	18,462	18,468	18,472	18,744	18,900

LEGEND

ECW — Energy Conservation Wheel
Edb — Entering Dry Bulb
Ewb — Entering Wet Bulb
SHC — Sensible Heat Capacity (Btuh)
TC — Total Capacity (Btuh) Gross
W — Compressor Motor Power Input (W)

NOTES:

1. Direct interpolation is permissible. Do not extrapolate.
2. Cooling capacities are gross and do not include deduction for indoor fan motor heat.

Performance data (cont)



COOLING CAPACITIES (cont)

62DA,DB AND 62DC,DD22 WITHOUT ECW

Entering Air Quantity (Cfm)		Temp (F) Air Entering (Edb)									
		80					90				
		Entering Air — Ewb (F)									
		70	74	75	76	78	70	74	75	76	78
2400	TC	190,934	204,832	208,390	211,980	219,276	184,322	197,990	201,440	204,948	212,148
	SHC	98,648	86,450	83,394	80,328	74,364	121,880	110,476	107,516	104,476	98,428
	W	14,364	14,566	14,610	14,656	14,704	15,748	15,936	15,984	16,034	16,130
3100	TC	208,624	223,192	226,890	230,598	238,062	200,556	214,858	218,448	222,102	229,488
	SHC	108,428	93,512	89,516	85,506	77,442	139,286	124,664	120,794	116,930	109,144
	W	14,896	15,040	15,086	15,132	15,222	16,268	16,468	16,516	16,564	16,662
3700	TC	219,260	234,132	237,856	241,612	249,094	210,204	224,848	228,504	232,194	239,620
	SHC	116,042	98,246	93,534	88,792	79,130	153,356	136,032	131,458	126,846	117,536
	W	15,274	15,416	15,462	15,508	15,596	16,642	16,840	16,888	16,936	17,032
4400	TC	228,270	243,162	246,914	250,694	258,154	218,140	232,972	236,646	240,326	247,762
	SHC	124,134	102,576	97,030	91,496	80,230	168,770	148,258	142,826	137,338	125,984
	W	15,664	15,822	15,866	15,910	15,996	17,072	17,222	17,272	17,320	17,456

62DA,DB AND 62DC,DD22 WITHOUT ECW (cont)

Entering Air Quantity (Cfm)		Temp (F) Air Entering (Edb)									
		100					105				
		Entering Air — Ewb (F)									
		70	74	75	76	78	70	74	75	76	78
2400	TC	176,958	190,056	193,298	196,714	203,746	172,788	185,664	188,922	192,292	199,272
	SHC	144,654	133,424	130,252	127,376	121,530	155,438	144,450	141,566	138,732	133,186
	W	17,342	17,542	17,590	17,638	17,738	18,232	18,430	18,482	18,532	18,620
3100	TC	191,776	205,048	208,574	212,320	219,160	186,822	200,310	203,622	207,026	213,962
	SHC	169,692	154,528	150,888	147,558	139,478	183,860	170,048	166,366	162,646	155,112
	W	17,852	18,070	18,118	18,154	18,270	18,840	18,926	18,978	19,028	19,132
3700	TC	200,594	214,228	217,744	220,938	227,940	204,732	208,656	212,474	215,442	221,792
	SHC	189,922	172,848	168,398	163,344	154,042	204,732	190,612	186,806	182,084	172,440
	W	18,244	18,424	18,474	18,538	18,672	19,302	19,316	19,352	19,394	19,510
4400	TC	214,036	221,634	225,140	228,182	235,740	218,946	219,542	219,260	222,170	229,358
	SHC	214,036	192,576	187,762	181,810	171,954	218,946	216,104	209,554	203,900	193,896
	W	18,834	18,852	18,856	18,918	19,000	19,806	19,796	19,748	19,840	19,950

62DC,DD22 WITH ECW

Entering Air Quantity (Cfm)		Temp (F) Air Entering (Edb)									
		75					85				
		Entering Air — Ewb (F)									
		57	62	67	72	75	57	62	67	72	75
4400	TC	170,400	185,600	201,700	217,800	227,200	187,800	186,800	203,100	220,300	230,600
	SHC	160,200	135,000	109,400	82,300	65,500	187,800	181,500	159,000	132,900	116,322
	W	17,080	17,324	17,556	17,800	17,934	17,382	17,342	17,562	17,820	17,970
5100	TC	175,500	190,700	207,100	223,100	232,400	197,600	198,000	208,400	225,700	236,000
	SHC	171,200	144,900	115,600	84,200	65,000	197,600	198,000	172,700	142,500	123,200
	W	17,438	17,676	17,900	18,144	18,270	17,804	17,810	17,930	18,180	18,338
5800	TC	184,200	194,700	211,100	227,000	236,200	205,600	206,000	212,600	229,700	240,200
	SHC	184,200	155,600	121,800	86,100	64,400	205,600	206,000	186,400	152,100	131,300
	W	17,836	17,992	18,222	18,464	18,586	18,166	18,172	18,262	18,504	18,640
6500	TC	189,900	197,500	213,800	229,900	239,000	212,300	212,700	215,700	232,700	242,900
	SHC	189,900	165,300	126,600	87,900	63,700	212,300	212,700	195,200	161,700	137,700
	W	18,194	18,306	18,570	18,766	18,890	18,538	18,542	18,578	18,810	18,964

LEGEND

- ECW — Energy Conservation Wheel
- Edb — Entering Dry Bulb
- Ewb — Entering Wet Bulb
- SHC — Sensible Heat Capacity (Btuh)
- TC — Total Capacity (Btuh) Gross
- W — Compressor Motor Power Input (W)

NOTES:

1. Direct interpolation is permissible. Do not extrapolate.
2. Cooling capacities are gross and do not include deduction for indoor fan motor heat.

COOLING CAPACITIES (cont)

62DA,DB AND 62DC,DD24 WITHOUT ECW

Entering Air Quantity (Cfm)		Temp (F) Air Entering (Edb)									
		80					90				
		Entering Air — Ewb (F)									
		70	74	75	76	78	70	74	75	76	78
2400	TC	205,724	220,558	224,386	228,256	236,080	198,676	213,372	217,158	220,960	228,678
	SHC	106,552	94,520	91,062	87,906	81,544	129,188	117,794	114,826	111,820	105,696
	W	15,932	16,174	16,284	16,352	16,488	17,698	17,934	18,002	18,070	18,212
3600	TC	236,784	252,612	256,646	260,812	269,054	227,472	243,254	247,296	251,348	259,564
	SHC	123,340	105,172	100,486	96,510	87,104	159,394	142,134	137,694	133,236	124,090
	W	17,008	17,304	17,382	17,400	17,536	18,712	18,992	19,070	19,140	19,284
4800	TC	253,822	270,020	274,414	278,556	286,802	242,914	258,870	262,954	267,106	270,540
	SHC	137,372	113,102	108,422	102,296	89,896	186,266	162,766	156,828	150,974	139,180
	W	17,818	18,168	18,118	18,192	18,344	18,910	19,922	20,008	20,044	20,192
6000	TC	264,360	280,650	284,744	288,838	296,822	253,068	268,782	272,780	276,420	285,028
	SHC	157,414	121,828	114,318	106,904	90,794	211,176	184,850	177,464	169,284	155,412
	W	18,436	12,728	18,806	18,886	19,072	20,160	20,424	20,508	20,616	20,760

62DA,DB AND 62DC,DD24 WITHOUT ECW (cont)

Entering Air Quantity (Cfm)		Temp (F) Air Entering (Edb)									
		100					105				
		Entering Air — Ewb (F)									
		70	74	75	76	78	70	74	75	76	78
2400	TC	191,034	205,130	208,796	212,546	220,094	186,920	200,720	204,430	209,408	215,308
	SHC	151,736	140,210	137,352	134,470	128,608	162,738	151,330	148,736	145,882	139,622
	W	19,690	19,952	20,018	20,088	20,232	20,794	21,076	21,126	21,200	21,358
3600	TC	217,720	231,952	235,862	239,948	247,480	212,712	226,586	230,418	233,694	241,576
	SHC	194,634	176,898	172,750	168,774	159,338	211,946	194,832	190,842	185,982	177,556
	W	20,722	21,022	21,098	21,164	21,354	21,834	22,100	22,176	22,280	22,426
4800	TC	237,886	246,560	250,428	254,274	261,214	243,270	241,056	244,378	247,470	254,868
	SHC	237,144	211,640	205,998	200,856	188,258	243,270	236,682	230,402	224,196	212,742
	W	21,698	21,920	21,926	21,960	22,250	23,086	22,912	23,026	23,192	23,354
6000	TC	256,524	255,400	258,486	262,360	269,858	262,074	262,726	262,898	262,964	262,470
	SHC	256,524	245,806	238,254	231,494	215,568	262,074	262,726	262,898	262,964	247,418
	W	22,556	22,610	22,702	22,772	22,982	23,980	23,966	23,962	24,258	24,140

62DC,DD24 WITH ECW

Entering Air Quantity (Cfm)		Temp (F) Air Entering (Edb)									
		75					85				
		Entering Air — Ewb (F)									
		57	62	67	72	75	57	62	67	72	75
6000	TC	200,100	216,900	234,900	252,200	262,300	226,000	226,400	236,500	255,200	266,400
	SHC	197,400	167,500	131,800	95,000	72,600	22,600	226,400	199,500	163,800	141,200
	W	2,092	20,462	20,768	21,136	21,348	20,644	20,652	20,778	21,172	21,516
7000	TC	211,900	221,800	239,200	256,800	266,700	236,400	236,800	241,400	259,600	271,400
	SHC	211,900	182,000	139,600	97,300	71,300	236,400	236,800	213,600	176,600	152,300
	W	20,748	20,868	21,316	21,636	21,862	21,242	21,250	21,278	21,710	21,942
8000	TC	218,900	225,200	242,700	260,100	269,700	244,400	244,800	244,500	263,300	274,300
	SHC	218,900	190,100	148,500	100,400	69,900	244,400	244,800	228,700	191,100	161,200
	W	21,282	21,342	21,698	22,092	22,332	21,806	21,814	21,822	22,156	22,456
9000	TC	224,500	227,200	245,300	262,300	271,700	251,000	251,300	251,700	265,000	276,500
	SHC	224,500	200,100	157,200	102,800	69,400	251,000	251,300	251,700	196,200	171,300
	W	21,782	21,802	22,122	22,534	22,758	22,270	22,278	22,286	22,626	22,904

LEGEND

ECW — Energy Conservation Wheel
Edb — Entering Dry Bulb
Ewb — Entering Wet Bulb
SHC — Sensible Heat Capacity (Btuh)
TC — Total Capacity (Btuh) Gross
W — Compressor Motor Power Input (W)

NOTES:

1. Direct interpolation is permissible. Do not extrapolate.
2. Cooling capacities are gross and do not include deduction for indoor fan motor heat.

Performance data (cont)



COOLING CAPACITIES (cont)

62DA,DB AND 62DC,DD30 WITHOUT ECW

Entering Air Quantity (Cfm)		Temp (F) Air Entering (Edb)									
		80					90				
		Entering Air — Ewb (F)									
		70	74	75	76	78	70	74	75	76	78
3400	TC	283,720	304,194	309,482	314,870	325,740	273,728	294,058	299,386	304,614	315,358
	SHC	146,666	129,070	124,708	120,304	111,406	179,140	162,874	158,848	154,534	145,930
	W	22,016	22,314	22,372	22,432	22,556	24,074	24,296	24,356	24,420	24,556
4600	TC	316,004	337,748	343,410	348,998	360,196	303,746	325,326	330,852	334,340	347,518
	SHC	163,710	140,662	135,736	129,734	117,652	209,524	187,672	182,112	176,312	164,734
	W	22,924	23,184	23,152	23,224	23,370	24,916	25,176	25,266	25,342	25,498
5800	TC	336,956	359,378	365,012	370,640	381,904	322,928	345,216	350,752	356,334	367,622
	SHC	178,770	151,016	143,632	136,132	120,976	237,440	210,516	203,292	196,024	181,484
	W	23,646	23,838	23,914	23,990	24,146	25,638	25,936	26,018	26,100	26,266
7000	TC	366,406	386,560	390,358	395,978	406,642	350,208	371,840	376,480	381,366	393,382
	SHC	215,052	171,558	158,522	148,012	125,044	308,806	266,366	255,284	242,972	222,516
	W	25,204	25,502	26,010	26,068	26,244	27,266	27,588	27,772	27,886	28,036

62DA,DB AND 62DC,DD30 WITHOUT ECW (cont)

Entering Air Quantity (Cfm)		Temp (F) Air Entering (Edb)									
		100					105				
		Entering Air — Ewb (F)									
		70	74	75	76	78	70	74	75	76	78
3400	TC	262,690	282,546	287,606	292,748	303,270	256,810	276,654	281,608	286,550	296,874
	SHC	210,490	194,824	190,684	186,718	178,424	226,016	211,248	207,294	203,014	194,754
	W	26,510	26,692	26,772	26,830	26,962	27,830	28,012	28,074	28,152	28,294
4600	TC	290,578	311,174	316,118	321,880	332,468	283,608	303,756	308,346	314,072	324,684
	SHC	254,600	232,710	226,490	221,794	209,940	275,760	255,080	248,734	244,094	232,944
	W	27,282	27,570	27,674	27,718	27,874	28,706	28,868	28,978	29,026	29,186
5800	TC	308,130	329,032	333,708	339,018	350,358	316,096	320,506	325,740	330,974	340,728
	SHC	294,908	268,314	260,294	252,964	239,638	316,096	296,266	289,348	282,440	267,844
	W	28,042	28,306	28,414	28,556	28,650	29,646	29,642	29,726	29,818	30,032
7000	TC	360,364	361,266	359,030	362,328	378,506	367,208	368,054	368,278	368,508	368,984
	SHC	360,364	361,266	348,704	337,130	272,428	367,208	368,054	368,278	368,508	364,742
	W	30,110	30,240	30,052	30,284	30,300	31,956	31,944	31,940	31,938	31,930

62DC,DD30 WITH ECW

Entering Air Quantity (Cfm)		Temp (F) Air Entering (Edb)									
		75					85				
		Entering Air — Ewb (F)									
		57	62	67	72	75	57	62	67	72	75
7,000	TC	256,800	278,600	301,800	324,900	338,600	285,700	281,600	303,700	328,500	343,300
	SHC	242,200	206,900	165,700	123,100	96,300	285,700	277,900	244,400	202,700	176,600
	W	26,482	26,796	27,144	27,468	27,698	26,950	26,884	27,158	27,556	27,812
8,400	TC	271,200	286,300	309,700	333,000	246,300	301,900	302,400	311,700	336,600	351,600
	SHC	271,200	221,400	177,000	127,000	95,300	301,900	302,400	263,200	221,700	191,400
	W	27,270	27,456	27,824	28,138	28,368	27,736	27,744	27,864	28,236	28,492
9,600	TC	280,500	290,800	314,800	337,400	350,700	312,800	313,300	316,800	341,300	356,400
	SHC	280,500	235,100	188,000	129,200	92,800	312,800	313,300	282,600	238,100	203,700
	W	27,866	27,990	28,326	28,720	28,986	28,364	28,372	28,404	28,766	29,038
11,000	TC	289,100	295,200	318,200	341,200	354,100	322,900	323,400	322,200	345,100	360,000
	SHC	289,100	251,600	197,800	132,700	90,600	322,900	323,400	305,200	247,100	217,300
	W	28,532	28,564	28,962	29,320	29,596	29,070	29,076	28,996	29,388	29,650

LEGEND

- ECW — Energy Conservation Wheel
- Edb — Entering Dry Bulb
- Ewb — Entering Wet Bulb
- SHC — Sensible Heat Capacity (Btuh)
- TC — Total Capacity (Btuh) Gross
- W — Compressor Motor Power Input (W)

NOTES:

1. Direct interpolation is permissible. Do not extrapolate.
2. Cooling capacities are gross and do not include deduction for indoor fan motor heat.

COOLING CAPACITIES (cont)

62DA,DB AND 62DC,DD34 WITHOUT ECW

Entering Air Quantity (Cfm)		Temp (F) Air Entering (Edb)									
		80					90				
		Entering Air — Ewb (F)									
		70	74	75	76	78	70	74	75	76	78
4000	TC	344,470	369,854	376,454	383,028	393,538	333,168	358,390	364,832	371,376	383,964
	SHC	178,354	158,574	153,592	147,488	136,736	216,298	197,752	192,838	187,868	177,448
	W	28,242	28,632	28,710	28,942	29,600	31,032	31,350	31,458	31,570	31,942
5300	TC	382,924	406,546	413,360	420,218	433,974	369,166	395,036	401,844	408,634	422,508
	SHC	197,684	170,946	164,156	157,276	143,048	250,590	224,976	218,414	211,752	198,452
	W	29,704	30,382	30,524	30,668	30,970	32,100	32,710	32,840	32,974	33,276
6700	TC	406,926	434,102	440,974	447,976	461,776	393,320	420,660	427,984	434,972	445,666
	SHC	215,394	182,294	173,868	165,318	147,138	283,036	251,016	243,748	235,384	217,500
	W	30,980	31,538	31,692	31,854	32,208	33,292	33,852	33,960	34,118	34,502
8000	TC	423,776	451,114	457,988	464,968	478,968	409,304	436,664	442,082	448,350	461,232
	SHC	229,924	190,402	180,232	170,052	150,010	312,640	274,118	261,240	256,108	234,238
	W	31,888	32,514	32,680	32,852	33,164	34,122	34,742	35,430	35,026	35,878

62DA,DB AND 62DC,DD34 WITHOUT ECW (cont)

Entering Air Quantity (Cfm)		Temp (F) Air Entering (Edb)									
		100					105				
		Entering Air — Ewb (F)									
		70	74	75	76	78	70	74	75	76	78
4000	TC	320,896	345,218	351,360	357,768	369,806	313,896	337,698	343,962	350,428	361,910
	SHC	254,322	235,756	230,574	225,826	215,668	272,032	253,600	248,972	244,750	234,512
	W	34,162	34,574	34,700	34,810	35,252	35,986	36,418	36,532	36,614	37,142
5300	TC	353,516	377,990	385,062	391,616	404,718	345,916	369,362	375,126	381,624	395,168
	SHC	301,190	275,794	270,340	263,746	250,086	326,120	301,960	294,716	288,388	276,310
	W	35,324	36,016	36,102	36,248	36,564	37,234	37,846	38,024	38,168	38,438
6700	TC	376,804	401,302	407,752	415,210	428,288	382,518	391,332	398,442	405,670	417,644
	SHC	349,972	317,424	309,222	302,246	284,916	382,518	349,804	342,548	335,612	319,102
	W	36,562	37,096	37,248	37,360	37,724	39,020	39,170	39,170	39,286	39,578
8000	TC	401,102	417,422	423,200	430,406	442,536	410,450	406,318	413,066	418,852	430,998
	SHC	396,964	355,896	346,162	336,334	316,574	410,450	389,974	385,910	376,224	356,216
	W	37,758	37,992	38,108	38,424	36,606	40,216	39,940	40,080	40,226	40,748

62DC,DD34 WITH ECW

Entering Air Quantity (Cfm)		Temp (F) Air Entering (Edb)									
		75					85				
		Entering Air — Ewb (F)									
		57	62	67	72	75	57	62	67	72	75
8,000	TC	311,100	337,800	366,500	395,400	412,900	343,600	340,900	368,900	399,700	418,700
	SHC	285,700	244,800	197,700	149,500	118,900	343,600	325,700	283,000	239,500	211,200
	W	33,956	34,552	35,126	35,612	36,022	34,648	34,612	35,076	35,866	36,176
9,400	TC	321,100	347,100	376,100	405,100	422,500	361,900	362,500	379,200	409,800	429,000
	SHC	309,500	259,100	209,200	153,200	117,818	361,900	362,500	307,600	259,400	226,100
	W	34,646	35,280	35,888	36,388	36,810	35,564	35,578	35,812	36,552	36,978
10,300	TC	333,400	351,600	381,000	409,900	427,000	371,700	372,300	384,400	415,200	433,900
	SHC	333,400	269,300	216,700	155,500	117,100	371,700	372,300	322,000	272,900	235,500
	W	35,228	35,722	36,344	36,862	37,282	36,124	36,138	36,278	36,984	37,462
12,000	TC	346,400	357,800	387,500	416,600	433,500	387,000	387,500	390,500	421,700	439,800
	SHC	346,400	287,900	230,500	159,600	155,500	387,000	387,500	345,100	284,200	250,700
	W	36,262	36,526	37,162	37,696	38,122	37,128	37,142	37,428	37,842	38,460

LEGEND

- ECW** — Energy Conservation Wheel
- Edb** — Entering Dry Bulb
- Ewb** — Entering Wet Bulb
- SHC** — Sensible Heat Capacity (Btuh)
- TC** — Total Capacity (Btuh) Gross
- W** — Compressor Motor Power Input (W)

NOTES:

1. Direct interpolation is permissible. Do not extrapolate.
2. Cooling capacities are gross and do not include deduction for indoor fan motor heat.

Performance data (cont)



COOLING CAPACITIES (cont)

62DA,DB AND 62DC,DD38 WITHOUT ECW

Entering Air Quantity (Cfm)		Temp (F) Air Entering (Edb)									
		80					90				
		Entering Air — Ewb (F)									
		70	74	75	76	78	70	74	75	76	78
4800	TC	368,166	391,784	398,130	404,726	418,482	355,204	380,434	387,074	393,778	407,372
	SHC	190,186	166,594	159,084	151,634	140,088	237,128	213,868	207,946	201,946	189,708
	W	30,154	30,582	31,142	31,358	31,418	32,964	33,476	33,570	33,666	33,862
6200	TC	396,396	423,290	430,088	436,972	450,808	383,208	410,282	417,196	424,058	437,890
	SHC	208,090	177,452	169,226	161,328	145,040	270,500	241,130	233,752	226,136	210,378
	W	31,686	32,056	32,160	32,260	32,460	34,122	34,486	34,586	34,686	34,886
7600	TC	417,110	443,990	450,840	458,008	471,714	402,150	429,294	436,232	442,762	453,166
	SHC	225,458	186,900	177,206	168,580	148,364	302,314	265,890	276,604	246,156	227,072
	W	32,522	32,958	33,056	33,102	33,310	34,960	35,368	35,464	35,666	36,268
9000	TC	430,838	458,128	464,968	472,116	485,826	416,014	440,160	447,016	452,304	465,776
	SHC	239,662	195,446	184,164	173,742	150,906	334,658	292,024	281,288	267,468	244,922
	W	33,328	33,722	33,818	33,872	34,060	35,688	36,076	36,170	36,802	37,028

62DA,DB AND 62DC,DD38 WITHOUT ECW (cont)

Entering Air Quantity (Cfm)		Temp (F) Air Entering (Edb)									
		100					105				
		Entering Air — Ewb (F)									
		70	74	75	76	78	70	74	75	76	78
4800	TC	340,208	364,578	371,028	377,116	390,390	333,808	355,594	361,688	367,910	380,760
	SHC	282,066	259,862	254,200	247,546	235,972	305,710	282,066	276,078	270,166	258,748
	W	36,236	36,794	36,898	37,030	37,226	38,018	38,670	38,810	38,926	39,138
6200	TC	366,972	391,410	397,914	403,944	417,646	367,720	382,334	388,634	393,332	405,832
	SHC	331,890	302,274	294,850	286,420	271,758	366,062	332,780	325,466	316,664	301,458
	W	37,440	37,806	37,916	38,056	38,252	39,316	39,720	39,828	39,932	40,172
7600	TC	384,776	409,714	414,818	420,524	433,608	399,194	398,862	404,314	411,168	422,316
	SHC	378,480	343,112	332,942	322,708	304,178	399,194	380,428	370,900	362,932	342,734
	W	38,390	38,708	38,802	39,030	39,238	40,840	40,640	40,732	40,800	41,226
9000	TC	415,364	420,640	426,688	433,270	447,612	423,956	425,076	425,368	421,648	432,908
	SHC	415,364	381,356	370,486	359,786	340,280	423,956	425,076	420,390	405,804	383,594
	W	39,520	39,596	39,692	39,796	39,842	41,888	41,858	41,850	41,786	42,010

62DC,DD38 WITH ECW

Entering Air Quantity (Cfm)		Temp (F) Air Entering (Edb)									
		75					85				
		Entering Air — Ewb (F)									
		57	62	67	72	75	57	62	67	72	75
9,000	TC	328,500	357,200	387,000	417,300	434,800	366,900	367,700	389,200	421,500	441,500
	SHC	312,100	266,400	211,800	157,500	123,100	366,900	369,300	312,500	258,900	227,200
	W	36,024	36,492	37,160	37,570	37,866	36,796	36,696	37,202	37,768	37,976
10,000	TC	335,900	363,300	393,600	423,800	441,000	379,800	380,600	396,100	428,600	447,700
	SHC	331,500	279,600	220,300	160,000	122,300	379,800	380,600	332,200	273,800	236,100
	W	36,512	37,058	37,666	38,074	38,362	37,410	37,424	37,708	38,140	38,604
11,000	TC	350,900	368,400	399,400	429,100	445,800	391,000	391,700	401,900	434,100	453,400
	SHC	350,900	293,900	230,300	163,000	120,300	391,000	391,700	352,400	288,100	247,600
	W	37,276	37,536	38,022	38,542	38,868	37,996	38,010	38,068	38,618	38,952
12,000	TC	358,900	372,800	403,100	433,200	449,900	400,800	401,400	406,100	437,600	457,200
	SHC	358,900	308,000	23,700	165,700	120,800	400,800	401,400	362,300	300,000	256,900
	W	37,814	38,058	38,606	38,996	39,282	38,556	38,600	38,570	39,112	39,440

LEGEND

- ECW — Energy Conservation Wheel
- Edb — Entering Dry Bulb
- Ewb — Entering Wet Bulb
- SHC — Sensible Heat Capacity (Btuh)
- TC — Total Capacity (Btuh) Gross
- W — Compressor Motor Power Input (W)

NOTES:

1. Direct interpolation is permissible. Do not extrapolate.
2. Cooling capacities are gross and do not include deduction for indoor fan motor heat.

FAN PERFORMANCE

FORWARD CURVED FAN (9 x 7 in.)

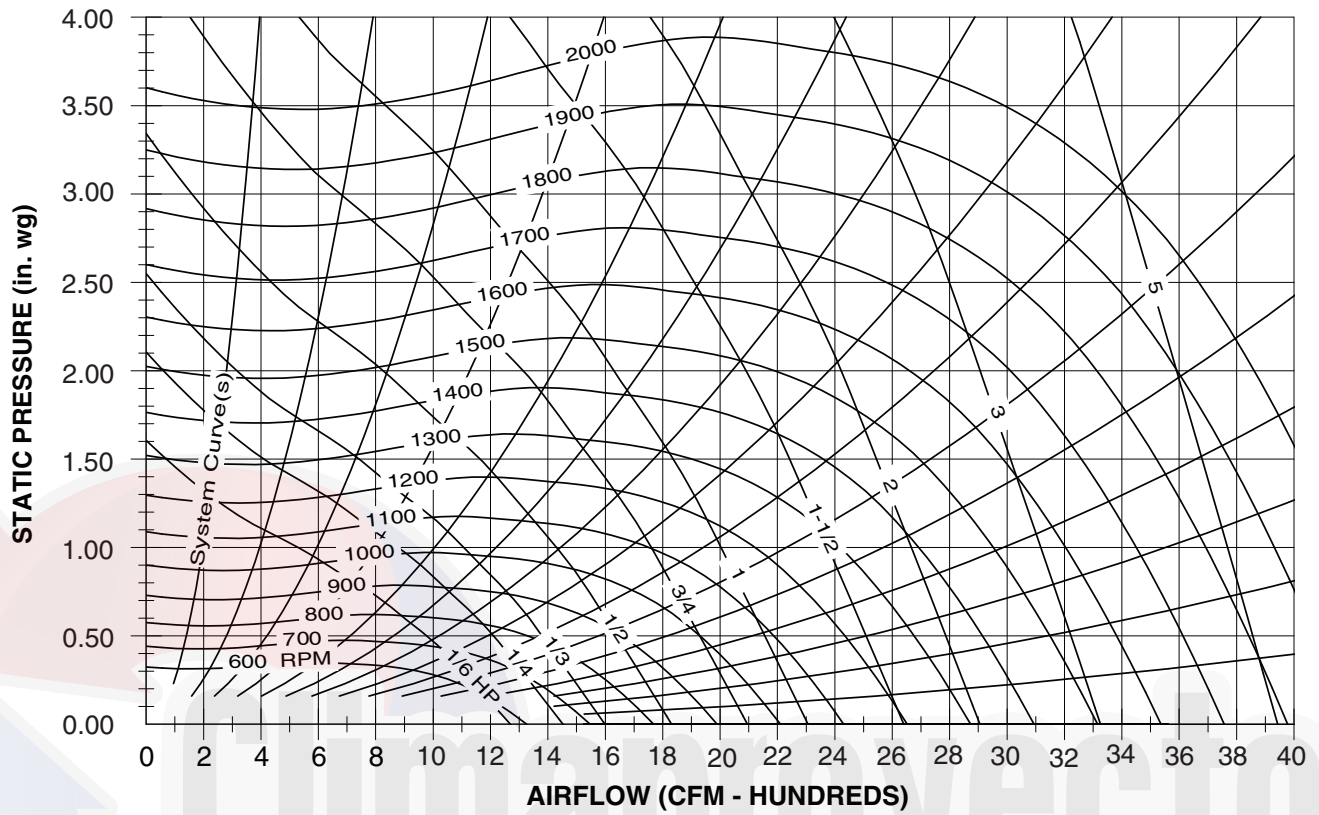

FORWARD CURVED FAN (12 x 9 in.)

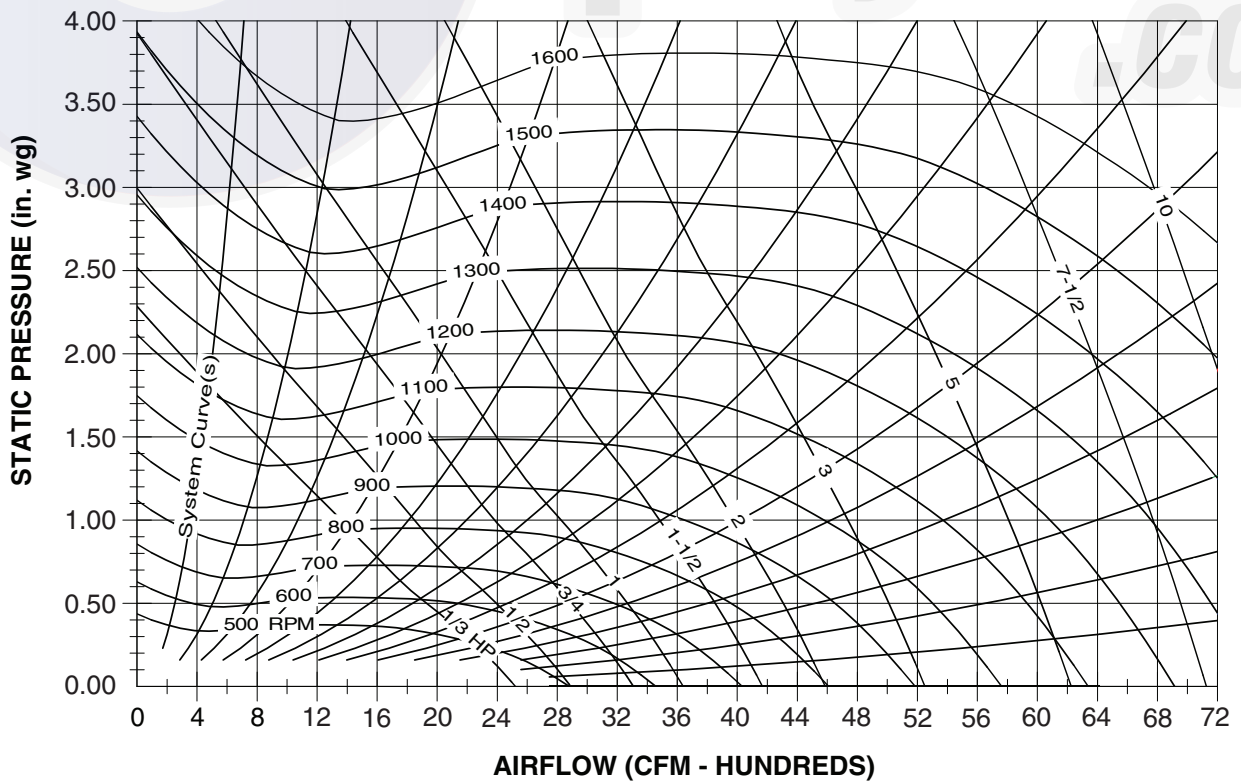

Performance data (cont)



FAN PERFORMANCE (cont)

AIRFOIL FAN (12 in.)

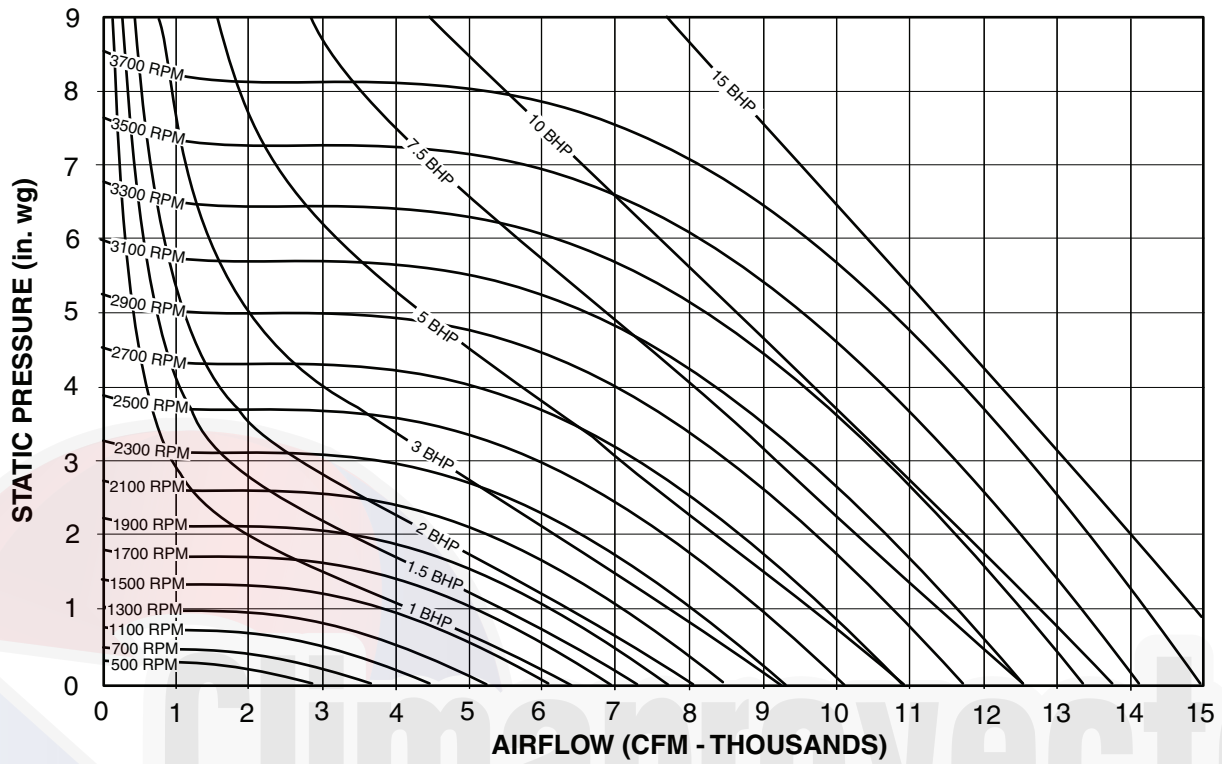

AIRFOIL FAN (15 in.)

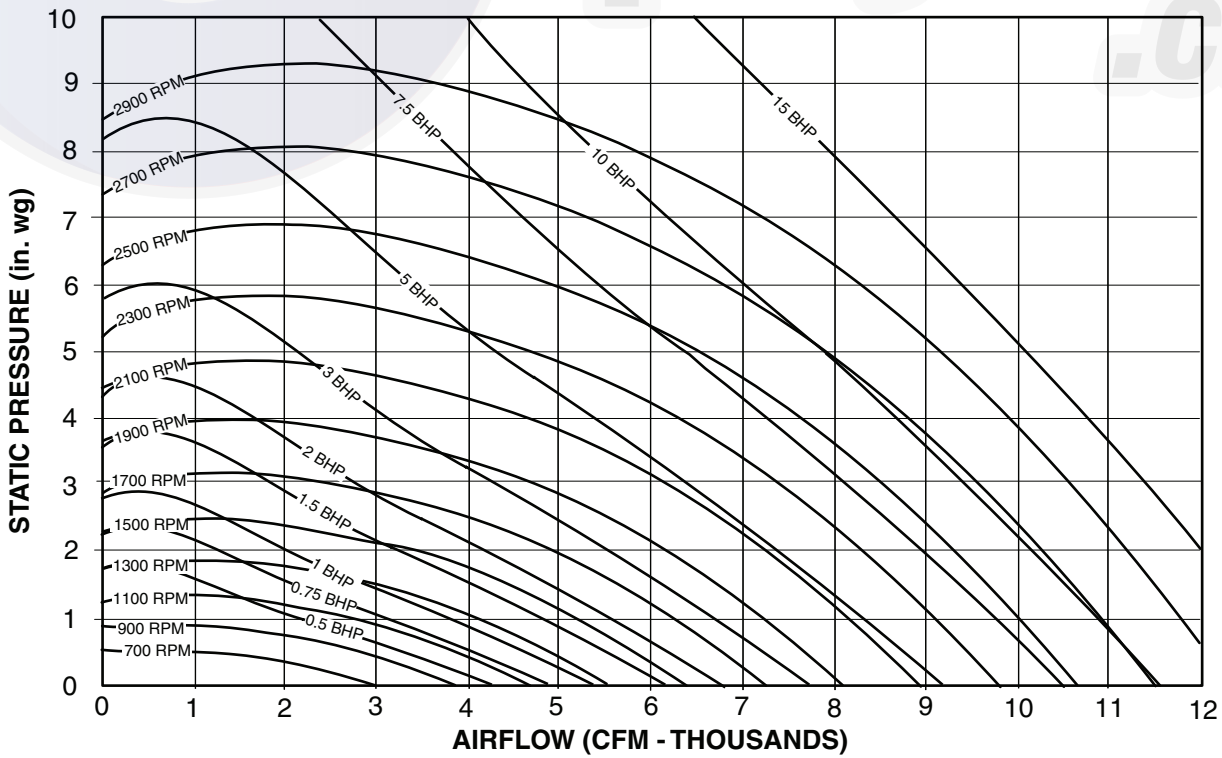

FAN PERFORMANCE (cont)

AIRFOIL FAN (18 in.)

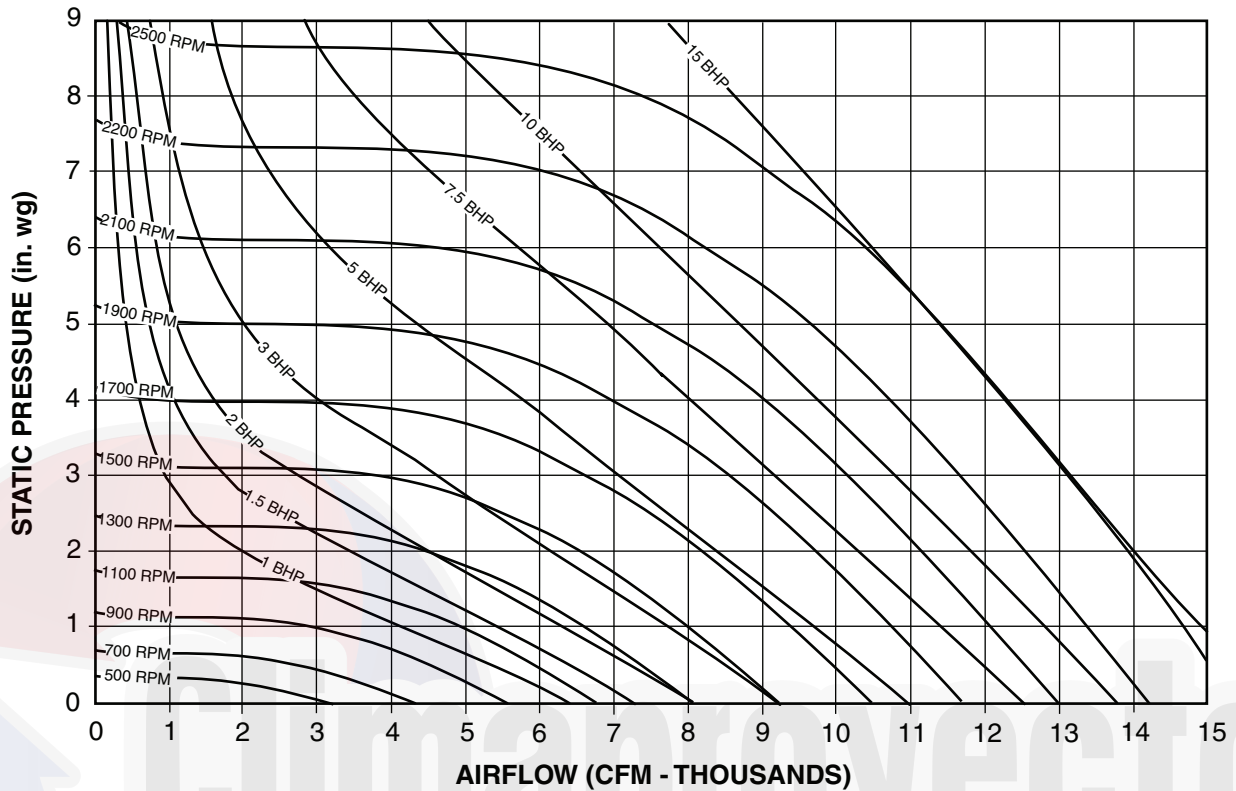

BACKWARD CURVED FAN (180 mm)

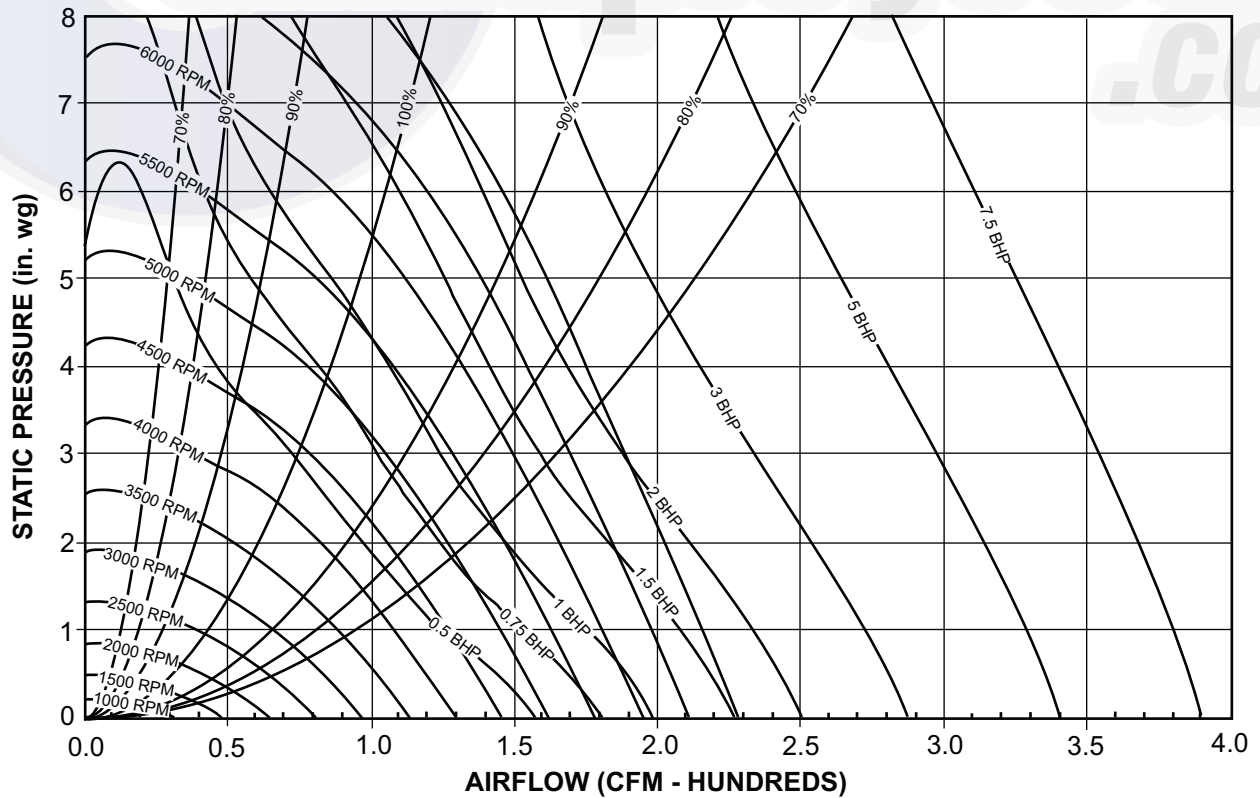

Performance data (cont)



FAN PERFORMANCE (cont)
BACKWARD INCLINED FAN (15-in.)

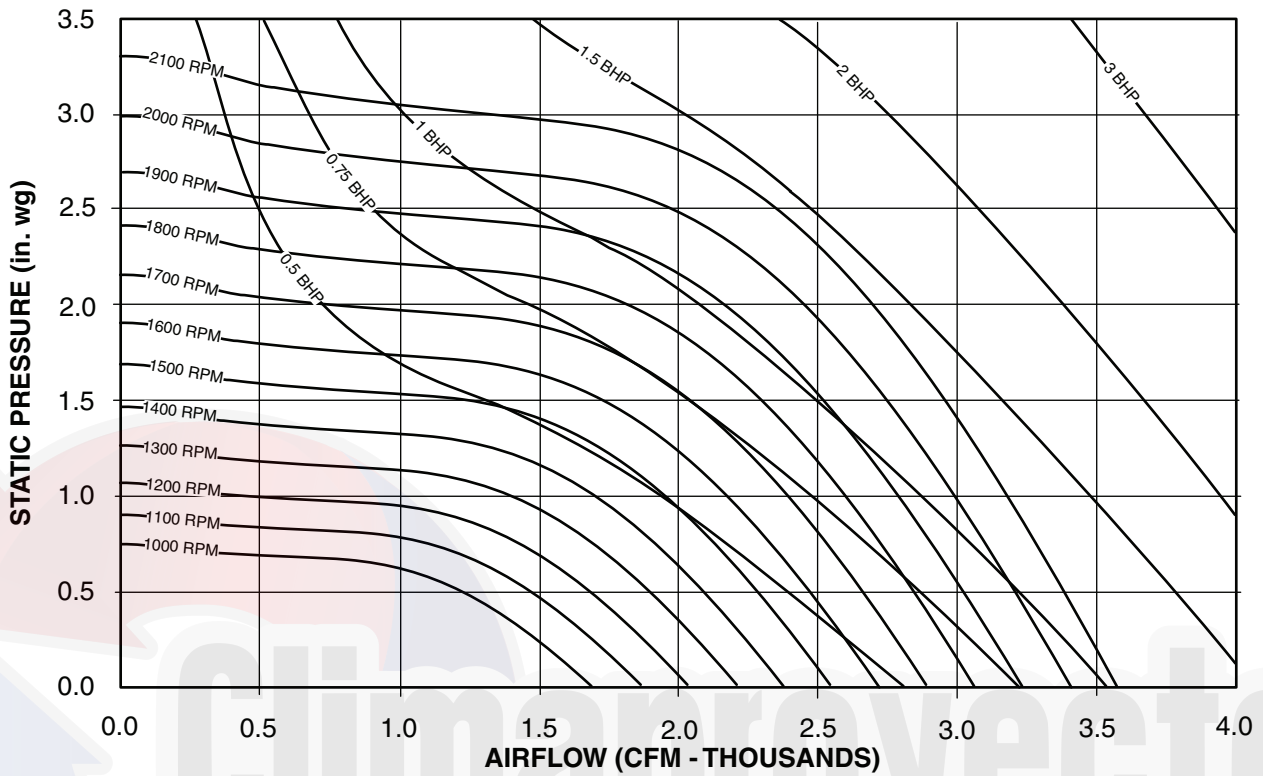

BACKWARD INCLINED FAN (18.5-in.)

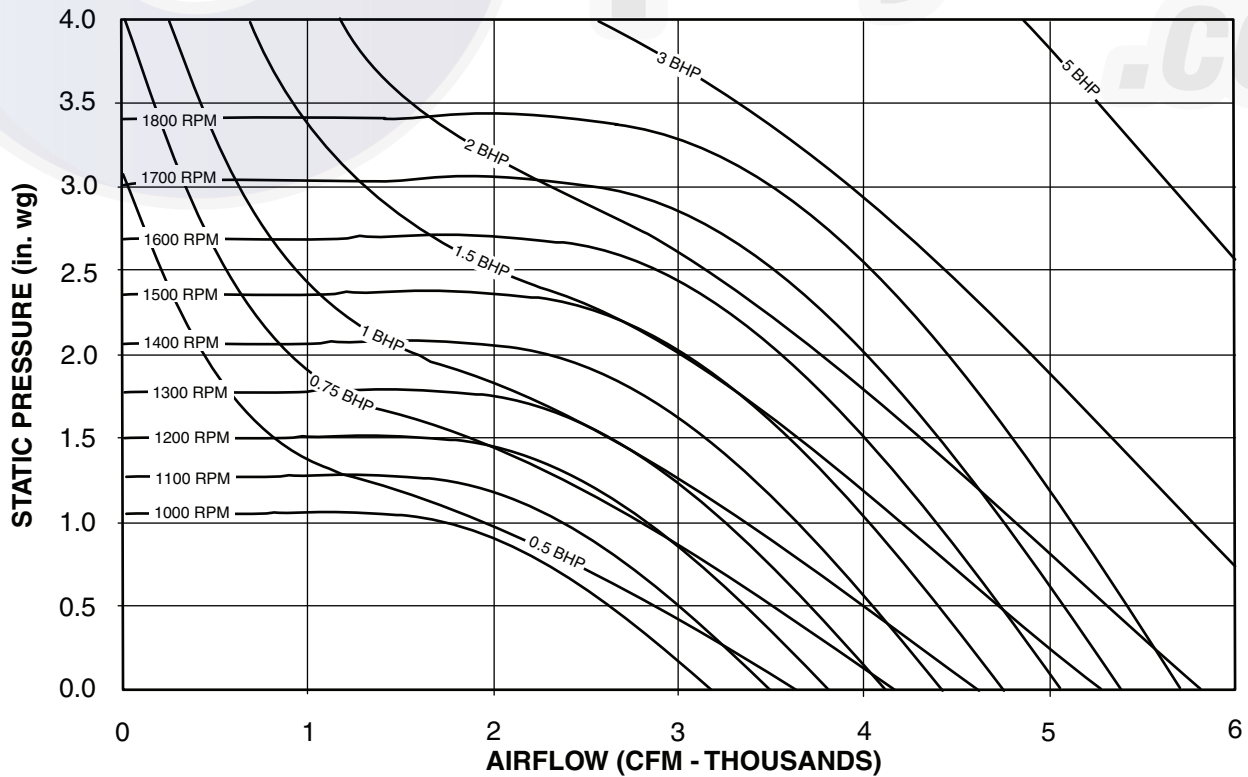

FAN PERFORMANCE (cont)
BACKWARD INCLINED FAN (24.5-in.)

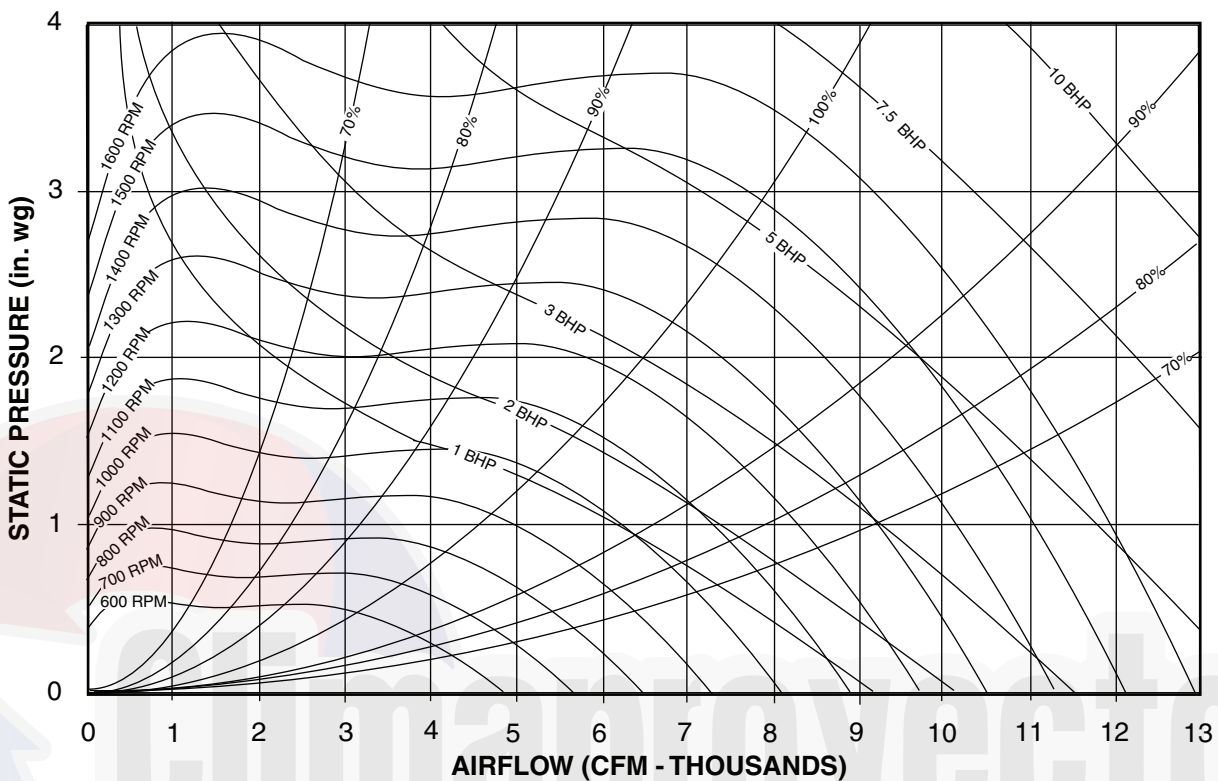

BACKWARD INCLINED FAN (27-in.)

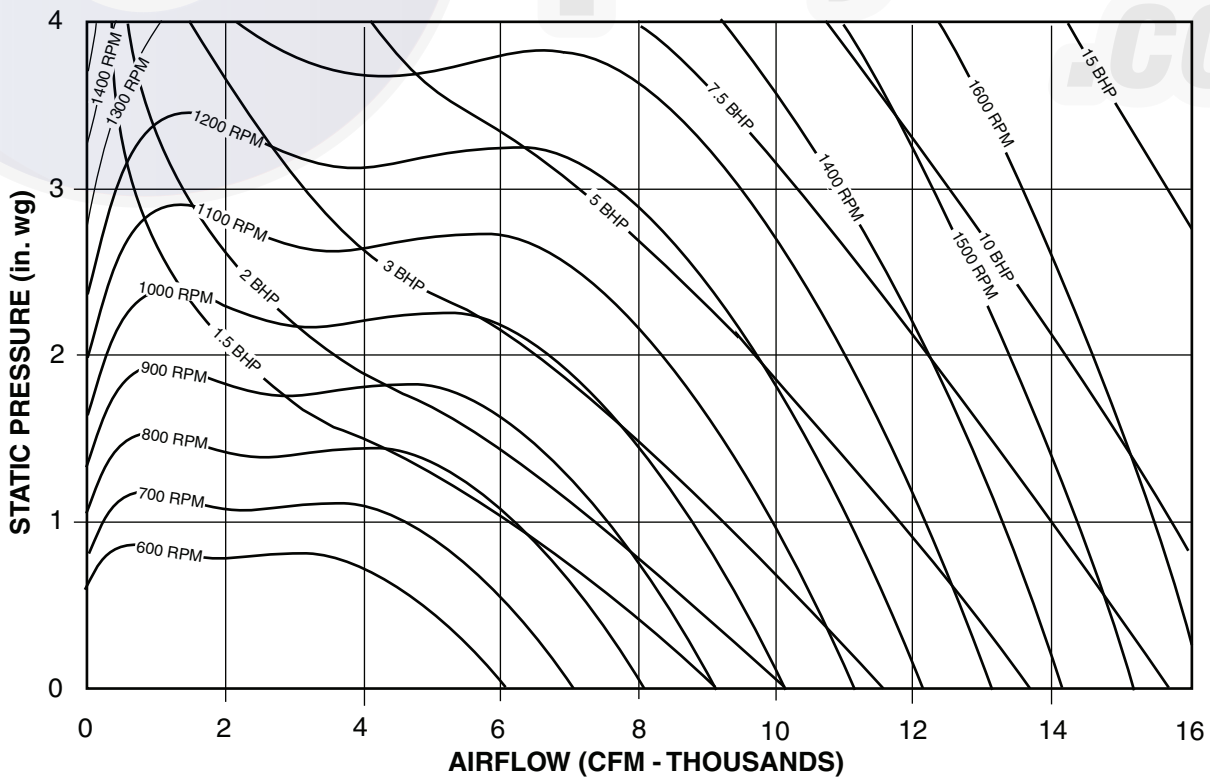

Performance data (cont)



COMPONENT PRESSURE DROPS (in. wg) UNITS 62DA,DB,DC,DD07-09

COMPONENT	SUPPLY AIR CFM								
	500	900	1300	1700	2100	2500	2900	3300	3500
Cabinet Loss	0.02	0.03	0.05	0.07	0.09	0.12	0.15	0.18	0.20
2-in. Cleanable Filters	0.01	0.01	0.01	0.02	0.03	0.03	0.04	0.05	0.05
2-in. Pleated MERV 8 Filters	0.03	0.04	0.05	0.08	0.10	0.11	0.11	0.12	0.13
4-in. Pleated MERV 8 Filters	0.03	0.04	0.05	0.06	0.08	0.08	0.09	0.09	0.10
4-in. Pleated MERV 11 Filters	0.04	0.06	0.07	0.10	0.12	0.11	0.14	0.15	0.16
4-in. Pleated MERV 14 Filters	0.07	0.10	0.15	0.18	0.22	0.23	0.24	0.26	0.27
Evaporator Coil (with ECW)	—	0.18	0.22	0.25	0.30	0.32	0.36	0.40	0.42
Evaporator Coil (without ECW)	0.16	0.20	0.24	0.28	0.32	0.36	0.40	0.45	—
Hot Gas Reheat Coil	0.01	0.01	0.02	0.02	0.03	0.04	0.05	0.06	0.07
Liquid Subcooling Coil	0.01	0.01	0.02	0.02	0.03	0.04	0.05	0.06	0.07
Electric Heat 10-27 kW	0.01	0.01	0.01	0.01	0.02	0.03	0.04	0.05	0.07
Electric Heat 30-60 kW	0.31	0.31	0.31	0.31	0.32	0.33	0.34	0.35	0.37
100% Outdoor Air Damper	0.01	0.01	0.01	0.02	0.03	0.04	0.05	0.07	0.07
Gas Heat 75,000 Btuh Input	0.01	0.02	0.03	0.05	0.06	0.07	0.09	0.10	0.12
Gas Heat 100,000 Btuh Input	0.01	0.02	0.04	0.05	0.07	0.08	0.10	0.12	0.13
Gas Heat 150,000 Btuh Input	0.01	0.03	0.05	0.06	0.08	0.09	0.11	0.13	0.15
Gas Heat 200,000 Btuh Input	0.01	0.03	0.06	0.07	0.09	0.10	0.12	0.14	0.16
Hot Water Coil	0.01	0.01	0.01	0.02	0.02	0.03	0.05	0.06	0.06
Steam Coil	0.01	0.01	0.01	0.01	0.01	0.02	0.02	0.03	0.03
Optional Energy Wheel	0.26	0.47	0.66	0.88	1.09	1.29	1.50	1.70	—

COMPONENT PRESSURE DROPS (in. wg) UNITS 62DA,DB,DC,DD12-20

COMPONENT	SUPPLY AIR CFM								
	1300	1950	2600	3250	3900	4550	5200	5850	6500
Cabinet Loss	0.05	0.09	0.12	0.19	0.24	0.37	0.50	0.63	0.77
2-in. Cleanable Filters	0.01	0.02	0.03	0.05	0.06	0.07	0.08	0.09	0.10
2-in. Pleated MERV 8 Filters	0.05	0.07	0.10	0.12	0.15	0.18	0.22	0.26	0.30
4-in. Pleated MERV 8 Filters	0.05	0.06	0.08	0.09	0.11	0.14	0.17	0.20	0.24
4-in. Pleated MERV 11 Filters	0.07	0.10	0.12	0.15	0.17	0.21	0.26	0.30	0.35
4-in. Pleated MERV 14 Filters	0.15	0.18	0.22	0.26	0.30	0.37	0.45	0.53	0.60
Evaporator Coil (with ECW)	—	0.20	0.23	0.25	0.35	0.39	0.40	0.44	0.55
Evaporator Coil (without ECW)	0.20	0.26	0.28	0.37	0.42	0.46	—	—	—
Hot Gas Reheat Coil	0.04	0.05	0.06	0.07	0.08	0.10	0.11	0.13	0.15
Liquid Subcooling Coil	0.04	0.05	0.06	0.07	0.08	0.10	0.11	0.13	0.15
Electric Heat 10-27 kW	0.01	0.02	0.04	0.06	0.08	0.12	0.15	0.19	0.24
Electric Heat 30-60 kW	0.31	0.32	0.34	0.36	0.38	0.42	0.45	0.49	0.54
100% Outdoor Air Damper	0.01	0.02	0.04	0.07	0.10	0.13	0.17	0.22	0.27
Gas Heat 150,000 Btuh Input	0.01	0.03	0.04	0.07	0.11	0.15	0.20	0.25	0.31
Gas Heat 200,000 Btuh Input	0.01	0.03	0.05	0.08	0.12	0.17	0.22	0.27	0.34
Gas Heat 250,000 Btuh Input	0.01	0.03	0.06	0.09	0.13	0.18	0.24	0.30	0.37
Gas Heat 300,000 Btuh Input	0.02	0.04	0.07	0.10	0.15	0.20	0.26	0.33	0.40
Hot Water Coil	0.01	0.02	0.03	0.05	0.07	0.10	0.13	0.16	0.20
Steam Coil	0.01	0.01	0.02	0.03	0.04	0.05	0.06	0.08	0.10
Standard Energy Wheel	0.66	0.99	1.33	1.61	—	—	—	—	—
Optional Energy Wheel	0.37	0.56	0.74	0.93	1.11	1.30	1.48	—	—

**COMPONENT PRESSURE DROPS (in. wg)
UNITS 62DA,DB,DC,DD22-38**

COMPONENT	SUPPLY AIR CFM								
	2800	3400	4000	4400	5000	7000	8500	10000	12000
Cabinet Loss	0.06	0.14	0.22	0.30	0.38	0.42	0.50	0.61	0.72
2-in. Cleanable Filters	0.01	0.01	0.02	0.02	0.04	0.06	0.08	0.10	0.12
2-in. Pleated MERV 8 Filters	0.04	0.05	0.07	0.09	0.10	0.17	0.25	0.32	0.38
4-in. Pleated MERV 8 Filters	0.02	0.03	0.05	0.06	0.08	0.15	0.21	0.27	0.32
4-in. Pleated MERV 11 Filters	0.05	0.06	0.08	0.10	0.12	0.20	0.29	0.36	0.44
4-in. Pleated MERV 14 Filters	0.08	0.10	0.12	0.14	0.18	0.30	0.40	0.50	0.60
Evaporator Coil (with ECW)	—	—	—	0.30	0.32	0.33	0.39	0.45	0.98
Evaporator Coil (without ECW)	0.28	0.30	0.32	0.34	0.38	0.44	0.50	0.65	—
Hot Gas Reheat Coil	0.04	0.04	0.05	0.06	0.07	0.08	0.10	0.13	0.25
Liquid Subcooling Coil	0.04	0.04	0.05	0.06	0.07	0.08	0.10	0.13	0.25
Electric Heat 10-27 kW	0.10	0.11	0.12	0.13	0.14	0.16	0.18	0.20	0.22
Electric Heat 30-60 kW	0.40	0.41	0.42	0.43	0.44	0.46	0.48	0.50	0.52
100% Outdoor Air Damper	0.01	0.02	0.03	0.04	0.05	0.06	0.08	0.10	0.12
Gas Heat 300,000 Btuh input	0.07	0.10	0.13	0.17	0.23	0.40	0.52	—	—
Gas Heat 400,000 Btuh input	—	0.15	0.21	0.28	0.36	0.48	0.57	0.68	—
Gas Heat 500,000 Btuh input	—	—	0.19	0.25	0.32	0.40	0.48	0.54	0.71
Gas Heat 600,000 Btuh input	—	—	—	—	0.30	0.38	0.45	0.52	0.67
Hot Water Coil	0.06	0.08	0.10	0.12	0.14	0.16	0.20	0.26	0.50
Steam Coil	0.04	0.04	0.05	0.06	0.07	0.08	0.10	0.13	0.25
Standard Energy Wheel	1.04	1.27	1.49	1.64	—	—	—	—	—
Optional Energy Wheel	0.80	0.97	1.14	1.25	1.42	1.99	—	—	—



Performance data (cont)



ENERGY CONSERVATION WHEEL PERFORMANCE

36-in. WHEEL

COOLING MODE												HEATING MODE					
Return Air = 75 db / 63 wb												Return Air = 70 db / 58 wb					
db	95						90						-10	0	10	20	30
wb	63	67	71	75	78	80	63	67	71	75	78	80	-11	-1	9	19	29
900 CFM																	
Total MBH	-0.1	10.3	21.9	34.5	44.9	52.2	-0.1	10.4	21.9	34.6	45.0	52.3	95.3	85.6	75.3	63.9	50.8
Sens. MBH	16.9	16.9	16.9	16.9	16.9	16.9	12.7	12.7	12.7	12.7	12.7	12.7	67.8	59.3	50.8	42.4	33.9
Lvg. DB	77.6	77.6	77.6	77.6	77.6	77.6	76.9	76.9	76.9	76.9	76.9	76.9	59.8	61.0	62.3	63.6	64.9
Lvg. WB	63.0	63.6	64.2	64.9	65.5	65.9	63.0	63.6	64.3	65.0	65.5	65.9	52.1	52.7	53.4	54.1	55.0
1200 CFM																	
Total MBH	0.0	13.2	27.8	43.9	57.0	66.2	0.0	13.3	27.9	43.9	57.0	66.3	121.1	108.9	95.8	81.3	64.6
Sens. MBH	21.6	21.6	21.6	21.6	21.6	21.6	16.2	16.2	16.2	16.2	16.2	16.2	86.4	75.6	64.8	54.0	43.2
Lvg. DB	78.3	78.3	78.3	78.3	78.3	78.3	77.5	77.5	77.5	77.5	77.5	77.5	56.7	58.4	60.0	61.7	63.3
Lvg. WB	63.0	63.7	64.6	65.6	66.2	66.7	63.0	63.8	64.6	65.5	66.2	66.8	50.1	51.0	51.9	52.9	54.0
1500 CFM																	
Total MBH	0.2	16.9	35.2	55.3	67.8	83.4	0.1	16.9	35.2	55.3	67.8	83.5	144.4	129.8	114.2	96.9	77.1
Sens. MBH	27.3	27.3	27.3	27.3	27.3	27.3	20.5	20.5	20.5	20.5	20.5	20.5	103.3	90.3	77.4	64.5	51.6
Lvg. DB	78.1	78.1	78.1	78.1	78.1	78.1	77.3	77.3	77.3	77.3	77.3	77.3	53.8	55.8	57.8	59.9	61.9
Lvg. WB	62.9	63.7	64.5	65.4	66.0	66.6	63.0	63.7	64.5	65.4	66.0	66.6	48.2	49.3	50.4	51.6	53.0
1800 CFM																	
Total MBH	0.4	18.3	38.1	59.8	77.5	89.9	0.3	18.3	38.0	59.7	77.4	89.9	165.3	148.6	130.7	110.9	88.2
Sens. MBH	29.6	29.6	29.6	29.6	29.6	29.6	22.2	22.2	22.2	22.2	22.2	22.2	118.5	103.7	88.9	74.0	59.2
Lvg. DB	79.8	79.8	79.8	79.8	79.8	79.8	78.6	78.6	78.6	78.6	78.6	78.6	51.0	53.3	55.7	58.1	60.5
Lvg. WB	62.9	64.0	65.2	66.5	67.5	68.2	63.0	64.1	65.3	66.5	67.5	68.2	46.3	47.6	49.0	50.4	52.1
2100 CFM																	
Total MBH	0.6	20.6	42.4	66.5	86.0	99.9	0.5	20.4	42.3	66.3	85.9	99.8	184.0	165.4	145.4	124.4	98.2
Sens. MBH	33.0	33.0	33.0	33.0	33.0	33.0	24.5	24.5	24.5	24.5	24.5	24.5	132.2	115.7	99.2	82.6	66.1
Lvg. DB	80.4	80.4	80.4	80.4	80.4	80.4	79.1	79.1	79.1	79.1	79.1	79.1	48.3	51.0	53.7	56.4	59.2
Lvg. WB	62.9	64.2	65.5	66.9	68.0	68.8	63.0	64.2	65.5	67.0	68.1	68.9	44.5	46.0	47.6	49.3	51.2
2400 CFM																	
Total MBH	0.9	22.6	46.3	72.4	93.7	108.7	0.7	22.4	46.1	72.2	93.5	108.6	200.7	180.4	158.6	134.6	107.1
Sens. MBH	36.1	36.1	36.1	36.1	36.1	36.1	27.1	27.1	27.1	27.1	27.1	27.1	144.6	126.5	108.5	90.3	72.3
Lvg. DB	81.1	81.1	81.1	81.1	81.1	81.1	79.5	79.5	79.5	79.5	79.5	79.5	45.8	48.8	51.8	54.9	57.9
Lvg. WB	62.8	64.3	65.8	67.3	68.6	69.4	62.9	64.3	65.8	67.4	68.6	69.5	42.6	44.4	46.2	48.2	50.4
2700 CFM																	
Total MBH	1.3	24.4	49.8	77.7	100.4	117	1.0	24.1	49.5	77.4	100.2	116.3	215.6	193.7	170.3	144.5	115.0
Sens. MBH	38.9	38.9	38.9	38.9	38.9	38.9	29.2	29.2	29.2	29.2	29.2	29.2	155.6	136.2	116.7	97.3	77.8
Lvg. DB	81.7	81.7	81.7	81.7	81.7	81.7	80.0	80.0	80.0	80.0	80.0	80.0	43.4	46.7	50.0	53.4	56.7
Lvg. WB	62.8	64.4	66.0	67.7	69.1	70.0	62.9	64.5	66.1	67.8	69.1	70.1	40.9	42.8	44.9	47.1	49.6
3000 CFM																	
Total MBH	1.6	26.1	52.9	82.4	106.4	123.4	1.2	25.7	52.6	82.0	106.0	123.1	228.8	205.6	180.7	153.4	122.0
Sens. MBH	41.4	41.4	41.4	41.4	41.4	41.4	31.0	31.0	31.0	31.0	31.0	31.0	165.6	144.9	124.2	103.5	82.8
Lvg. DB	82.2	82.2	82.2	82.2	82.2	82.2	80.4	80.4	80.4	80.4	80.4	80.4	41.1	44.7	48.3	51.9	55.6
Lvg. WB	62.8	64.5	66.3	68.1	69.5	70.5	62.9	64.6	66.3	68.2	69.6	70.6	39.1	41.3	43.6	46.1	48.8

LEGEND

- DB — Dry Bulb Temperature (F)
- Lvg. — Leaving
- MBH — Btuh x 1000
- Sens. — Sensible
- WB — Wet Bulb Temperature (F)

ENERGY CONSERVATION WHEEL PERFORMANCE (cont)

42-in. WHEEL

COOLING MODE												HEATING MODE					
Return Air = 75 db / 63 wb												Return Air = 70 db / 58 wb					
db	95						90					-10	0	10	20	30	
wb	63	67	71	75	78	80	63	67	71	75	78	80	-11	-1	9	19	29
1200 CFM																	
Total MBH	-0.2	13.9	29.3	46.2	60.1	69.9	-0.1	13.9	29.4	46.3	60.2	70.0	127.5	114.7	100.9	85.6	52.8
Sens. MBH	22.7	22.7	22.7	22.7	22.7	22.7	17.0	17.0	17.0	17.0	17.0	17.0	90.7	79.4	68.0	56.7	35.1
Lvg. DB	77.5	77.5	77.5	77.5	77.5	77.5	76.9	76.9	76.9	76.9	76.9	76.9	60.0	61.3	62.5	63.8	66.2
Lvg. WB	63.0	63.6	64.2	64.9	65.5	65.8	63.0	63.6	64.2	64.9	65.5	65.9	52.2	52.8	53.5	54.2	55.8
1600 CFM																	
Total MBH	-0.1	17.7	37.3	58.8	76.4	88.8	0.0	17.8	37.4	58.9	76.5	88.9	162.3	145.9	128.4	108.9	86.6
Sens. MBH	28.9	28.9	28.9	28.9	28.9	28.9	21.7	21.7	21.7	21.7	21.7	21.7	114.9	101.3	86.8	72.3	57.9
Lvg. DB	78.2	78.2	78.2	78.2	78.2	78.2	77.4	77.4	77.4	77.4	77.4	77.4	57.0	58.6	60.3	61.9	63.5
Lvg. WB	63.0	63.7	64.5	65.4	66.1	66.6	63.0	63.8	64.6	65.6	66.2	66.7	50.3	51.1	52.0	53.0	54.1
2000 CFM																	
Total MBH	0.1	21.3	44.6	70.1	91.0	105.7	0.1	21.3	44.6	70.1	91.0	105.8	193.7	174.2	153.2	130.0	103.4
Sens. MBH	34.6	34.6	34.6	34.6	34.6	34.6	25.9	25.9	25.9	25.9	25.9	25.9	138.5	121.2	103.9	86.5	69.3
Lvg. DB	79.0	79.0	79.0	79.0	79.0	79.0	78.0	78.0	78.0	78.0	78.0	78.0	54.1	56.1	58.1	60.1	62.1
Lvg. WB	62.9	63.9	64.9	65.9	66.8	67.4	63.0	63.9	64.9	66.0	66.8	67.4	48.4	49.5	50.6	51.8	53.2
2400 CFM																	
Total MBH	0.5	24.6	51.1	80.3	104.0	120.9	0.3	24.5	51.1	80.2	104.0	120.9	222.0	199.6	175.5	148.9	118.5
Sens. MBH	39.8	39.8	39.8	39.8	39.8	39.8	29.8	29.8	29.8	29.8	29.8	29.8	159.1	139.2	119.4	96.4	79.5
Lvg. DB	79.7	79.7	79.7	79.7	79.7	79.7	78.5	78.5	78.5	78.5	78.5	78.5	51.4	53.7	56.0	58.4	60.7
Lvg. WB	62.9	64.0	65.2	66.4	67.4	68.1	63.0	64.0	65.2	66.4	67.4	68.1	46.6	47.8	49.2	50.6	52.3
2800 CFM																	
Total MBH	0.8	27.6	57.0	89.3	115.7	134.4	0.6	27.5	56.9	89.2	115.6	134.3	274.4	222.4	195.5	165.9	132.0
Sens. MBH	44.4	44.4	44.4	44.4	44.4	44.4	33.3	33.3	33.3	33.3	33.3	33.3	177.7	155.5	133.3	111.1	88.9
Lvg. DB	80.3	80.3	80.3	80.3	80.3	80.3	79.0	79.0	79.0	79.0	79.0	79.0	48.8	51.4	54.1	56.7	59.4
Lvg. WB	62.9	64.1	65.4	66.8	67.9	68.7	63.0	64.2	65.5	66.9	68.0	68.8	44.8	46.3	47.8	49.5	51.4
3200 CFM																	
Total MBH	2.2	30.3	61.2	95.2	126.1	142.5	1.2	32.5	66.7	104.4	125.6	156.8	270.1	242.8	213.5	181.1	144.1
Sens. MBH	47.9	47.9	47.9	47.9	47.9	47.9	39.3	39.3	39.3	39.3	39.3	39.3	194.5	170.2	145.9	121.6	97.2
Lvg. DB	81.1	81.1	81.1	81.1	81.1	81.1	79.9	79.9	79.9	79.9	79.9	79.9	46.3	49.3	50.4	55.2	58.1
Lvg. WB	62.8	64.3	65.8	67.5	68.5	69.6	62.9	64.4	66.0	67.7	68.5	69.7	43.0	44.7	45.2	48.4	50.6
3600 CFM																	
Total MBH	2.8	32.8	65.8	101.9	135.4	152.3	2.1	32.2	65.1	101.3	135.1	156.8	290.5	261.0	229.5	194.7	154.9
Sens. MBH	51.6	51.6	51.6	51.6	51.6	51.6	38.7	38.7	38.7	38.7	38.7	38.7	209.6	183.4	157.2	131.0	104.8
Lvg. DB	81.7	81.7	81.7	81.7	81.7	81.7	80.0	80.0	80.0	80.0	80.0	80.0	43.9	47.2	50.4	53.7	57.0
Lvg. WB	62.7	64.3	66.1	67.9	69.0	70.2	62.8	64.5	66.1	67.9	69.0	69.9	43.0	43.2	45.2	47.3	49.7
4000 CFM																	
Total MBH	2.1	35.1	71.3	111.1	143.6	166.5	1.6	34.7	70.9	110.7	143.2	166.1	308.6	277.3	243.8	206.8	164.6
Sens. MBH	55.8	55.8	55.8	55.8	55.8	55.8	41.8	41.8	41.8	41.8	41.8	41.8	223.2	195.3	167.4	139.5	111.6
Lvg. DB	82.1	82.1	82.1	82.1	82.1	82.1	80.3	80.3	80.3	80.3	80.3	80.3	41.7	45.2	48.8	52.3	55.8
Lvg. WB	62.8	64.4	66.2	68.0	69.4	70.4	62.9	64.5	66.3	68.1	69.5	70.5	39.6	41.7	43.9	46.3	49.0

LEGEND

- DB** — Dry Bulb Temperature (F)
- Lvg.** — Leaving
- MBH** — Btuh x 1000
- Sens.** — Sensible
- WB** — Wet Bulb Temperature (F)

Performance data (cont)



ENERGY CONSERVATION WHEEL PERFORMANCE (cont)

48-in. WHEEL

COOLING MODE												HEATING MODE					
Return Air = 75 db / 63 wb												Return Air = 70 db / 58 wb					
db	95						90					-10	0	10	20	30	
wb	63	67	71	75	78	80	63	67	71	75	78	80	-11	-1	9	19	29
1500 CFM																	
Total MBH	0.1	17.4	36.8	58.2	75.6	87.9	0.2	17.5	36.9	58.3	75.8	88.1	159.1	144.3	126.9	107.7	85.6
Sens. MBH	28.5	28.5	28.5	28.5	28.5	28.5	21.4	21.4	21.4	21.4	21.4	21.4	114.1	99.8	85.6	71.3	57.0
Lvg. DB	77.4	77.4	77.4	77.4	77.4	77.4	76.8	76.8	76.8	76.8	76.8	76.8	60.5	61.6	62.8	64.0	65.2
Lvg. WB	63.0	63.6	64.2	64.8	65.4	65.7	63.0	63.6	64.2	64.9	65.4	65.8	52.6	53.1	53.7	54.4	55.2
2000 CFM																	
Total MBH	0.1	22.3	47.0	74.2	96.3	112.0	0.1	22.4	47.1	74.3	96.4	112.1	204.6	184.0	161.9	137.4	109.2
Sens. MBH	36.5	36.5	36.5	36.5	36.5	36.5	27.4	27.4	27.4	27.4	27.4	27.4	145.9	127.6	109.4	91.2	72.9
Lvg. DB	78.1	78.1	78.1	78.1	78.1	78.1	77.3	77.3	77.3	77.3	77.3	77.3	57.6	59.1	60.7	62.2	63.8
Lvg. WB	63.0	63.7	64.5	65.3	66.0	66.5	63.0	63.7	64.5	65.4	66.1	66.5	50.7	51.5	52.3	53.2	54.3
2500 CFM																	
Total MBH	0.1	26.9	56.3	88.6	115.0	133.6	0.1	26.9	56.3	88.7	115.0	133.7	244.8	220.1	193.6	164.2	130.6
Sens. MBH	43.7	43.7	43.7	43.7	43.7	43.7	31.8	32.8	32.8	32.8	32.8	32.8	174.9	153.0	131.2	109.3	87.4
Lvg. DB	78.8	78.8	78.8	78.7	78.7	78.8	77.9	77.9	77.9	77.9	77.9	77.8	54.8	56.7	58.6	60.5	62.4
Lvg. WB	63.0	63.8	64.8	65.8	66.6	67.2	63.0	63.9	64.8	65.9	66.7	67.3	48.9	49.9	50.9	52.1	53.4
3000 CFM																	
Total MBH	0.5	31.1	64.7	101.7	131.8	153.1	0.4	31.0	64.7	101.7	131.8	153.1	281.1	252.7	222.2	188.6	150.0
Sens. MBH	50.3	50.3	50.3	50.3	50.3	50.3	37.7	37.7	37.7	37.7	37.7	37.7	201.3	176.1	151.0	125.8	100.6
Lvg. DB	79.5	79.5	79.5	79.5	79.5	79.5	78.3	78.3	78.3	78.3	78.3	78.3	52.1	54.4	56.6	58.8	61.1
Lvg. WB	62.9	64.0	65.1	66.3	67.2	67.9	63.0	64.0	65.1	66.3	67.3	67.9	47.1	48.3	49.6	50.9	52.5
3500 CFM																	
Total MBH	0.9	35.0	72.3	113.4	146.9	170.6	0.7	34.8	72.2	113.3	146.8	170.6	313.9	282.1	248.1	210.5	167.5
Sens. MBH	56.3	56.3	56.3	56.3	56.3	56.3	42.2	42.2	42.2	42.2	42.2	42.2	225.3	197.1	168.9	140.8	112.6
Lvg. DB	80.1	80.1	80.1	80.1	80.1	80.1	78.8	78.8	78.8	78.8	78.8	78.8	49.6	52.2	54.7	57.3	59.8
Lvg. WB	62.9	64.1	65.3	66.7	67.8	68.5	63.0	64.1	65.4	66.7	67.8	68.6	45.4	46.8	48.3	49.9	51.7
4000 CFM																	
Total MBH	1.4	38.5	79.2	123.9	160.4	186.3	1.1	38.2	78.9	123.7	160.2	186.1	343.4	308.7	271.4	230.3	183.2
Sens. MBH	61.7	61.7	61.7	61.7	61.7	61.7	46.3	46.3	46.3	46.3	46.3	46.3	247.0	216.1	185.3	154.4	123.5
Lvg. DB	80.7	80.7	80.7	80.7	80.7	80.7	79.3	79.3	79.3	79.3	79.3	79.3	47.2	50.0	52.9	55.7	58.6
Lvg. WB	62.8	64.2	65.6	67.1	68.3	69.1	62.9	64.3	65.7	67.2	68.3	69.2	43.7	45.3	47.0	48.8	50.9
4500 CFM																	
Total MBH	1.9	41.7	85.4	133.4	166.0	200.3	1.5	41.3	85.0	133.0	165.7	199.9	370.0	332.5	292.3	248.0	197.3
Sens. MBH	66.6	66.6	66.6	66.6	66.6	66.6	50.0	50.0	50.0	50.0	50.0	50.0	266.7	233.4	200.0	166.7	133.3
Lvg. DB	81.3	81.3	81.3	81.3	81.3	81.3	79.7	79.7	79.7	79.7	79.7	79.7	44.9	48.0	51.2	54.3	57.4
Lvg. WB	62.8	64.3	65.9	67.5	69.2	69.6	62.9	64.4	65.9	67.5	69.2	69.7	42.0	43.8	45.7	47.8	50.1
5000 CFM																	
Total MBH	2.5	44.7	91.0	144.9	183.3	212.7	1.9	44.1	90.5	141.4	182.8	212.2	393.8	353.9	311.1	263.9	210.0
Sens. MBH	71.1	71.1	71.1	71.1	71.1	71.1	50.0	50.0	50.0	50.0	50.0	53.3	284.5	248.9	213.4	177.8	142.3
Lvg. DB	81.8	81.8	81.8	81.8	81.8	81.8	79.7	79.7	79.7	79.7	79.7	80.1	42.7	46.1	49.5	52.9	56.3
Lvg. WB	62.8	64.4	66.1	67.8	69.2	70.2	62.9	64.5	66.1	67.9	69.3	70.2	40.3	42.4	44.5	46.8	49.3

LEGEND

- DB** — Dry Bulb Temperature (F)
- Lvg.** — Leaving
- MBH** — Btuh x 1000
- Sens.** — Sensible
- WB** — Wet Bulb Temperature (F)

ENERGY CONSERVATION WHEEL PERFORMANCE (cont)

54-in. WHEEL

COOLING MODE												HEATING MODE					
Return Air = 75 db / 63 wb												Return Air = 70 db / 58 wb					
db	95						90						-10	0	10	20	30
wb	63	67	71	75	78	80	63	67	71	75	78	80	-11	-1	9	19	29
5500 CFM																	
Total MBH	2.1	50.6	103.8	162.2	209.7	243.4	1.6	50.2	103.5	178.2	209.5	243.2	582.1	416.5	365.1	308.9	245.1
Sens. MBH	81.1	81.1	80.9	80.9	80.8	80.8	60.8	60.8	60.7	67.3	60.7	60.6	423.1	292.2	249.7	207.5	165.5
Lvg. DB	80.9	80.9	80.9	80.9	80.9	80.9	79.5	79.5	79.4	80.1	79.4	79.4	36.0	47.3	50.7	54.1	57.4
Lvg. WB	62.8	64.3	65.7	67.2	68.4	69.3	62.9	64.3	65.8	67.9	68.5	69.4	35.1	43.3	45.5	47.6	50.0
6000 CFM																	
Total MBH	2.6	53.7	109.5	170.8	220.7	256.1	2.1	53.1	109.1	185.3	220.4	255.8	492.1	440.7	386.1	326.5	258.9
Sens. MBH	85.6	85.6	85.5	85.4	85.4	85.3	64.3	64.2	64.2	70.2	64.1	64.1	355.3	309.8	264.6	219.8	175.2
Lvg. DB	81.4	81.4	81.4	81.3	81.3	81.3	79.8	79.8	79.8	80.4	79.8	79.8	42.2	45.8	49.4	53.0	56.5
Lvg. WB	62.8	64.3	65.9	67.5	68.8	69.7	62.9	64.4	66.1	68.1	68.9	69.8	40.0	42.2	44.5	46.9	49.4
6500 CFM																	
Total MBH	3.2	56.4	114.7	178.7	230.6	367.6	2.5	55.8	114.2	178.2	230.3	267.2	517.3	463.1	405.6	342.8	271.7
Sens. MBH	89.8	89.7	89.6	89.6	89.5	89.5	67.4	67.4	67.3	67.3	67.2	67.1	374.2	326.2	278.4	231.2	184.2
Lvg. DB	81.8	81.8	81.8	81.8	81.8	81.7	80.1	80.1	80.1	80.1	80.1	80.1	40.5	44.4	48.2	52	55.7
Lvg. WB	62.8	64.4	66.1	67.8	69.2	70.1	62.9	64.5	66.1	67.9	69.2	70.2	38.7	41.1	43.5	46.1	48.9
7000 CFM																	
Total MBH	3.8	59.1	119.5	185.9	239.9	278.1	2.9	58.3	118.8	185.3	239.4	277.6	540.6	483.7	423.5	357.7	283.5
Sens. MBH	93.7	93.6	93.5	93.4	93.3	93.3	70.4	70.3	70.2	70.1	70.1	70.1	391.7	341.3	291.3	241.7	192.5
Lvg. DB	82.2	82.2	82.2	82.2	82.2	82.2	80.4	80.4	80.4	80.4	80.4	80.4	39.0	43.0	47.1	51.0	54.9
Lvg. WB	62.8	64.5	66.2	68.1	69.5	70.5	62.9	64.6	66.3	68.1	69.6	70.6	37.5	40.0	42.6	45.4	48.3
7500 CFM																	
Total MBH	4.4	61.5	123.9	192.4	248.2	287.6	3.4	60.5	123.2	191.7	247.6	287.1	562.2	502.8	439.9	371.5	294.3
Sens. MBH	97.3	97.2	97.1	96.9	96.8	96.7	73.1	72.9	72.8	72.7	72.7	72.7	407.9	355.3	303.1	251.4	200.2
Lvg. DB	82.6	82.6	82.6	82.6	82.6	82.5	80.7	80.7	80.7	80.7	80.7	80.7	37.4	41.7	45.9	50.0	54.1
Lvg. WB	62.8	64.5	66.4	68.3	69.8	70.8	62.9	64.6	66.5	68.4	69.9	70.9	36.3	39.2	41.7	44.6	47.8
8000 CFM																	
Total MBH	4.9	63.7	127.9	198.4	255.7	296.3	3.8	62.6	127.1	197.6	255.1	295.6	582.1	520.3	455.1	384.2	304.2
Sens. MBH	100.5	100.4	100.3	100.1	100.1	99.9	75.5	75.4	75.3	75.2	75.1	75.1	423.1	368.3	314.1	260.4	207.3
Lvg. DB	83.0	83.1	83.1	82.9	82.9	82.9	81.1	81.1	81.0	81.1	81.1	81.1	36.0	40.4	44.8	49.1	53.4
Lvg. WB	62.8	64.6	66.6	68.6	70.1	71.2	62.9	64.7	66.6	68.6	70.2	71.3	35.1	38.0	40.9	43.9	47.2

LEGEND

- DB** — Dry Bulb Temperature (F)
- Lvg.** — Leaving
- MBH** — Btuh x 1000
- Sens.** — Sensible
- WB** — Wet Bulb Temperature (F)

Electrical data



COMPRESSOR ELECTRICAL DATA

VOLTAGE		UNIT SIZE 62D												
		07	08	09	12	14	15	16	20	22	24	30	34	38
Number of Compressors		1	1	1	2	2	2	2	2	2	2	2	2	4
208-230/3/60	RLA (each)	16.0	19.0	23.2	13.7	16.0	22.4	25.0	29.5	29.5	30.1	48.1	55.8	29.5
	LRA	110.0	123.0	164.0	83.1	110.0	149.0	164.0	195.0	195.0	225.0	245.0	340.0	195.0
460/3/60	RLA (each)	7.8	9.7	11.2	6.2	7.8	10.6	12.2	14.8	14.8	16.7	18.6	26.9	14.8
	LRA	52.0	62.0	75.0	41.0	52.0	75.0	100.0	95.0	95.0	114.0	125.0	173.0	95.0
575/3/60	RLA (each)	5.7	7.4	7.9	4.8	5.7	7.7	90.0	12.2	12.2	12.2	14.7	23.7	12.2
	LRA	38.9	50.0	54.0	33.0	38.9	54.0	78.0	80.0	80.0	80.0	100.0	132.0	80.0

CONDENSER FAN MOTOR ELECTRICAL DATA

VOLTAGE		UNIT SIZE 62D												
		07	08	09	12	14	15	16	20	22	24	30	34	38
Number of Fans		1	1	1	2	2	2	2	2	2	2	2	2	2
208/230-3-60	FLA	3.0	4.0	4.0	2.3	2.3	4.0	4.0	4.0	4.0	4.0	5.6	5.6	5.6
460-3-60	FLA	1.5	2.0	2.0	1.2	1.2	2.0	2.0	2.0	2.0	2.0	2.8	2.8	2.8
575-3-60	FLA	0.8	1.8	1.8	0.8	0.8	0.8	1.8	1.8	1.8	1.8	2.3	2.3	2.3

SUPPLY AND EXHAUST FAN MOTOR ELECTRICAL DATA

VOLTAGE		MOTOR HP										
		1/2	3/4	1	1 1/2	2	3	5	7 1/2	10	15	20
208/230-3-60	FLA	2.8	3.4	3.2	4.8	6.3	9.8	15.7	22.3	29.0	43.4	57.0
460-3-60	FLA	1.4	1.7	1.5	2.0	2.9	4.1	6.8	10.0	12.9	18.9	24.5
575-3-60	FLA	0.8	1.3	1.1	1.6	2.3	3.3	5.2	7.6	10.1	15.1	19.6

ENERGY CONSERVATION WHEEL ELECTRICAL DATA

VOLTAGE		WHEEL SIZE (in.)			
		36	42	48	54
208/230-3-60	FLA	2.5	2.5	2.5	3.0
460-3-60	FLA	1.3	1.3	1.3	1.5
575-3-60	FLA	1.0	1.3	1.0	1.5

LEGEND

- FLA — Full Load Amps
- LRA — Locked Rotor Amps
- RLA — Rated Load Amps

Controls



Control components

The 62D Series of dedicated outdoor air units use a micro-processor controller that has been specifically designed for Carrier dedicated outdoor air units. The controller monitors the operating conditions in the outdoor air unit and controls the compressors, fans, heating systems, and optional devices. The controller has the capability of communicating with all major building automation protocols including BACnet, Modbus, and LonWorks (option) protocols.

NOTE: The temperatures listed below are default values and may be adjusted to meet the needs of the application.

Sequence of operation — 100% outdoor air units — 62DA,DB,DC,DD

The ALC controller is turned on by a switch located on its front upper left corner. Several options exist for starting the unit, such as the Resident Program Scheduler or the Building Automation System (BAS). These control source options can be selected from the BACview display pad on the Configuration Set-Up screen (requires Admin password). The Resident Program has an adjustable scheduler that uses the internal timeclock to allow for separate Sequences for Occupied and Unoccupied periods. This can be accessed from the BACview display pad on the Schedules screen (requires user password).

NOTE: All temperature-related events have an additional “delay on make” to allow temperatures to settle.

Occupied mode — When the program control source (scheduler, BAS) calls for the start of the Occupied mode, the ALC controller will verify that no fault or shutdown conditions exist, and a 60-second time delay begins, after which the unit goes into Occupied mode.

Outdoor air damper (OD) — Approximately 5 seconds (fixed) after the unit goes into Occupied mode the outdoor air (OA) damper will open. The OA damper will remain open while the unit is in Occupied mode.

Supply fan (SF) — Approximately 2 minutes (fixed) after the start of the Occupied mode, the supply fan (SF) will turn on. If the SF is equipped with the optional SF VFD, the VFD will modulate fan speed to maintain duct static pressure. The SF will operate continuously during Occupied mode.

Optional exhaust fan (EF) — Approximately 2 minutes (fixed) after the start of the Occupied mode, the exhaust fan (EF) will turn on. If the EF is equipped with the optional EF VFD, the VFD will modulate fan speed to maintain duct static pressure. The EF will operate continuously during Occupied Mode.

Optional energy conservation wheel (ECW) — Approximately 2 minutes after the start of Occupied mode, the ECW is enabled. The ECW will operate as stand alone, based on the ECW controller. The ECW operation is enabled continuously during Occupied mode.

ECW operation — If the outdoor-air temperature (OAT) is more than 3° F (adjustable) above or below the return-air temperature (RAT), the ECW will operate. If the OAT is less than 3° F above or below the RAT, the wheel will not operate. If the OAT drops below 15 F, the ECW will turn

off, to prevent frosting. When the OAT rises above 15 F, the wheel will operate normally.

Optional VFD defrost — When the OAT drops below 15 F, the VFD signal will begin to decrease, slowing the ECW rotation. When the OAT drops to 0° F, the VFD signal will stop the wheel. When the OAT rises above 0° F, the wheel speed will increase until an OAT of 15 F is reached.

Optional ECW bypass — When the ECW is off, the ECW bypass damper is open. When the ECW is operating, the ERW bypass damper is closed.

Cooling mode — When the OAT is 1° F (adjustable) or more above the cooling leaving air temperature (C-LAT) set point (70 F, adjustable) Cooling mode is enabled. Compressor 1 (C1 or DC1, if digital) and condenser fan motor 1 (OFM1) are enabled.

OFM operation — OFM1 will operate based on a stand alone controller to maintain condenser head pressure.

DC1 operation — Compressor no. 1 is modulated by the ALC controller to maintain a suction line temperature (SLT) set point (if HGRH exists) or the C-LAT (if no HGRH exists).

If the OAT is 2° F (adjustable) above the C-LAT set point, C2 and OFM 2 (if equipped) are enabled.

If the LAT is 1° F below the C-LAT set point, hot gas reheat (HGRH, if equipped) and liquid line subcooling reheat (LSRH, if equipped) are enabled.

HGRH operation — The HGRH valve is modulated by the ALC controller to maintain the C-LAT set point. When the LAT is 2° F above the C-LAT set point, HGRH (if equipped) is disabled.

LSRH operation — The LSRH coil is cycled by the ALC controller to maintain the C-LAT set point. When the LAT is 2° F above the C-LAT set point, LSRH (if equipped) is disabled.

When the OAT matches the cooling LAT set point, C2 and OFM 2 (if equipped) are disabled. When the OAT is 1° F below the C-LAT set point, C1 and OFM1 are disabled and the unit will run in Fan Only mode.

Room temperature reheat override (RTRHO) — This override is available only if the unit is equipped with HGRH or HGRH/LSRH and RTRHO mode is enabled in the control menu.

When the unit is in Cooling mode or Dehumidification mode, RTRHO is enabled in the control menu, and the cooling zone air temperature (C-ZAT) 1° F (adjustable) or more above or below the C-ZAT setpoint (72 F, adjustable), RTRHO mode is enabled.

For every 1° F (adjustable) the ZAT is above the C-ZAT set point, the C-LAT set point is decreased by 3° F (adjustable), up to a maximum of 15 F (adjustable).

For every 1° F (adjustable) the ZAT is below the C-ZAT set point, the C-LAT set point is increased by 3° F (adjustable), up to a maximum of 15 F (adjustable).

The unit HGRH or LSRH will operate to maintain the new C-LAT set point.

Controls (cont)



When the ZAT equals the C-ZAT set point, RTRHO mode is disabled and Cooling or Dehumidification mode is enabled.

Dehumidification mode — Dehumidification is available only if the unit is equipped with HGRH or HRGH/LSRH and Dehumidification mode is enabled in the controls menu.

When OAT is above 60 F (adjustable), and the zone relative humidity (Z-RH) is 1% (adjustable) or more above the Z-RH set point (55% RH, adjustable), and there is no call for heating, Dehumidification mode is enabled. C1 or DC1, HGRH and LSRH (if equipped), and OFM 1 are enabled.

DC1 operation — Compressor no. 1 is modulated by the ALC controller to 100% operation.

HGRH operation — HGRH will modulate to maintain the LAT set point.

LSRH operation — LSRH will cycle to maintain the LAT set point.

When the Z-RH is 2% above the Z-RH set point, C2 and OFM 2 (if equipped) are enabled.

When Z-RH is 2% below the Z-RH set point, Dehumidification mode is disabled and Cooling, RTRHO or Fan mode is enabled.

Heating mode — When the OAT is 1° F (adjustable) or more above the heat OAT Heating enable set point, Heating Mode is enabled.

Staged heat (gas, electric) — The heat source is staged by the ALC controller based on the difference between the LAT and LAT set point.

Modulating heat (gas, electric, steam, hot water) — The heat source is modulated by the ALC controller to maintain the LAT set point.

When the OAT is 1° F above the OAT Heating enable set point, Heating Mode is disabled and the unit operates in Fan Only Mode.

Staged heat (gas, electric) — The heat source is staged by the ALC controller based on the difference between the LAT and LAT set point.

Modulating heat (gas, electric, steam, hot water) — The heat source is modulated by the ALC controller to maintain the LAT set point.

When the LAT is 1° F above the H-LAT set point, auxiliary heating is disabled.

When the OAT is above the HP-OAT enable set point, Heating mode is disabled.

Room temperature reheat override (RTRHO) — When the unit is in Heating mode, RTHO is enabled in the control menu, and the heating zone air temperature (H-ZAT) is 1° F (adjustable) or more above or below the H-ZAT set point (72 F, adjustable) RTHO mode is enabled.

For every 1° F (adjustable) the ZAT is above the H-ZAT set point, the H-LAT set point is decreased by 3° F (adjustable), up to a maximum of 15 F (adjustable).

For every 1° F (adjustable) the ZAT is below the H-ZAT set point, the H-LAT set point is increased by 3° F (adjustable), up to a maximum of 15 F (adjustable).

The unit heat pump or auxiliary heat source will operate to maintain the new H-LAT set point.

When the ZAT equals the H-ZAT set point, RTHO mode is disabled and Heating mode is enabled.

Fan Only mode — When the OAT is below the C-LAT set point, but above the OAT Heating enable set point and Dehumidification mode is not enabled, Fan Only mode is enabled.

No cooling or heat source is energized. Only the SF, EF (if equipped) and ECW (if equipped) will operate.

Unoccupied mode — When the program control source (Scheduler, BAS) or energy management relay (EMR) calls for the end of Occupied mode, the unit will enter Unoccupied mode.

The C1 or DC1 (if equipped), OFM1, C2 and OFM 2 (if equipped) and auxiliary heat sources will be disabled.

The SF and EF will continue to operate for 2 minutes, and then shut off.

After the SF and EF shut off, the ERW will shut off.

The OA damper will close.

TYPICAL CONTROLLER INPUTS

NUMBER	NAME	TYPE	SENSOR TYPE
UI-01	Outside Air Temperature	Analog	Type II Thermistor 10kΩ at 77 F
UI-02	Outside Air Humidity	Analog	0-10 vdc
UI-03	Leaving Air Temperature	Analog	Type II Thermistor 10kΩ at 77 F
UI-04	Zone Relative Humidity	Analog	0-10 vdc
UI-05	Supply Fan Static Pressure Transmitter	Analog	0-10 vdc
UI-06	Exhaust Fan Static Pressure Transmitter	Analog	0-10 vdc
UI-07	—	—	—
UI-08	Compressor 2 Suction Line Temperature	Binary	Type II Thermistor 10kΩ at 77 F
UI-09	Compressor 1 Suction Line Temperature	Analog	Type II Thermistor 10kΩ at 77 F
UI-10	Smoke Detector (NC), EMR (NC), LP1 (NO), LP2 (NO)	Analog	LP1-5kΩ, LP2-10kΩ, SD-20kΩ, EMR-40kΩ
UI-11	Clogged Filter Indicator (NO), C1 Current Sensor (NO), C2 Current Sensor (NO)	Analog	C1CS-5kΩ, C2CS-10kΩ, CFD-20kΩ
UI-12	ECW Wheel Motion Sensor (NO), SF Air Proving Switch (NO), EF Air Proving Switch (NO)	Analog	ECWCS-5kΩ, SFAPS-10kΩ, EFAPS-20kΩ

TYPICAL CONTROLLER OUTPUTS

NUMBER	NAME	OUTPUT TYPE
AO-01	Supply Fan VFD Modulation	0-10 vdc
AO-02	Exhaust Fan VFD Modulation	0-10 vdc
AO-03	Digital Compressor 2 Modulation	0-10 vdc
AO-04	Hot Gas Reheat (HGRH)/Discharge Valve Modulation	0-10 vdc
AO-05	Digital Compressor 1 Modulation	0-10 vdc
AO-06	SCR Heat or Modulating Gas Heat	0-10 vdc
BO-01	Supply Fan, Exhaust Fan	Relay / Triac Output
BO-02	Compressor (Y1)	Relay / Triac Output
BO-03	Compressor (Y2)	Relay / Triac Output
BO-04	Hot Gas Reheat Valve (HGRH)	Relay / Triac Output
BO-05	Stage 1 Heat (W1) or Heat Pump Heat	Relay / Triac Output
BO-06	OA Damper, ECW Motor, ECW Damper, Exhaust Fan	Relay / Triac Output

LEGEND

AO	—	Analog Output
BO	—	Binary Output
ECW	—	Energy Conservation Wheel
EF	—	Exhaust Fan
EMR	—	Energy Management Relay
HGRH	—	Hot Gas Reheat
LP	—	Low Pressure Switch
NC	—	Normally Closed (contact)
NO	—	Normally Open (contact)
OA	—	Outdoor Air
SF	—	Supply Fan
UI	—	Universal Input
VFD	—	Variable Frequency Drive

Typical wiring schematics

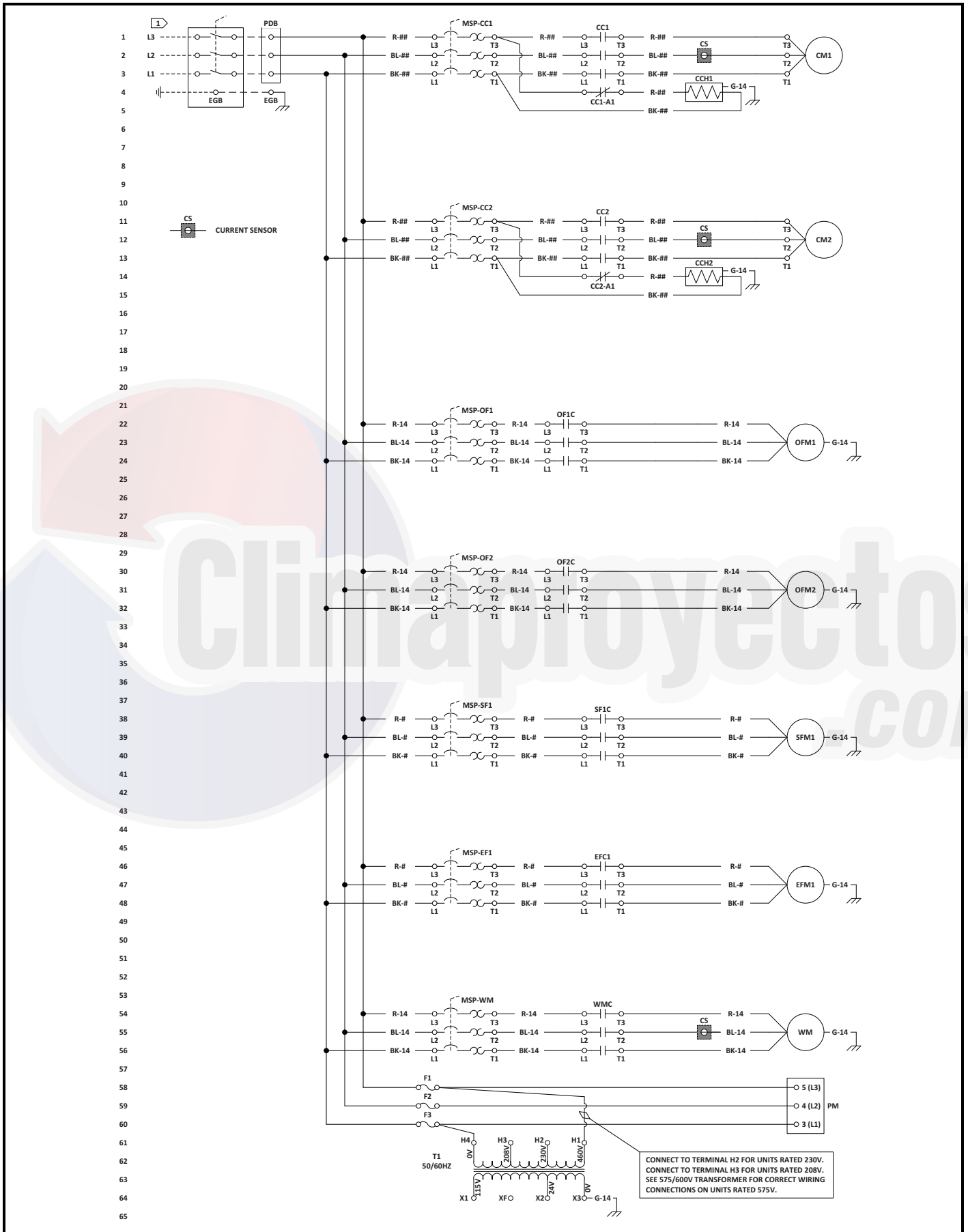

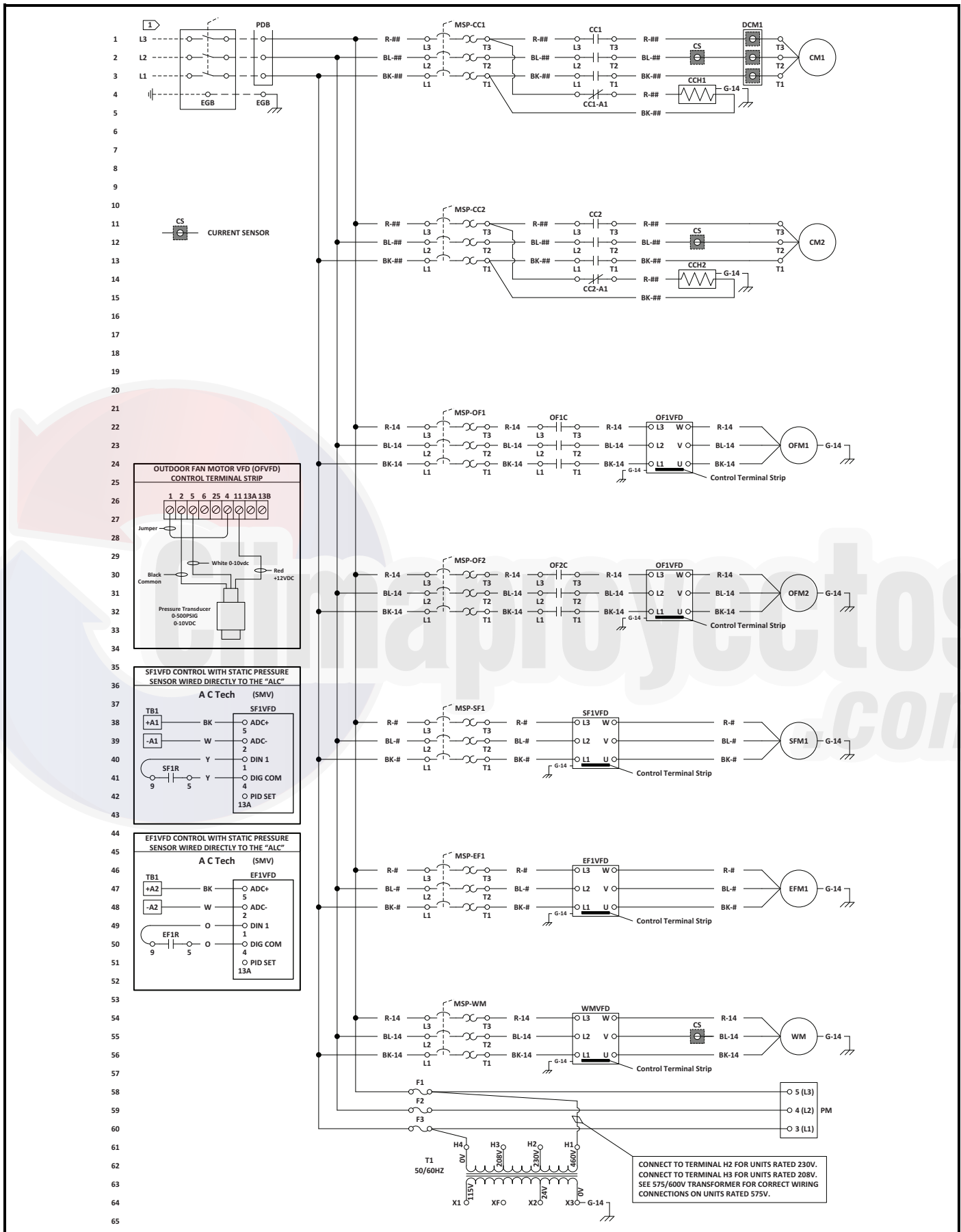

Typical wiring schematics (cont)

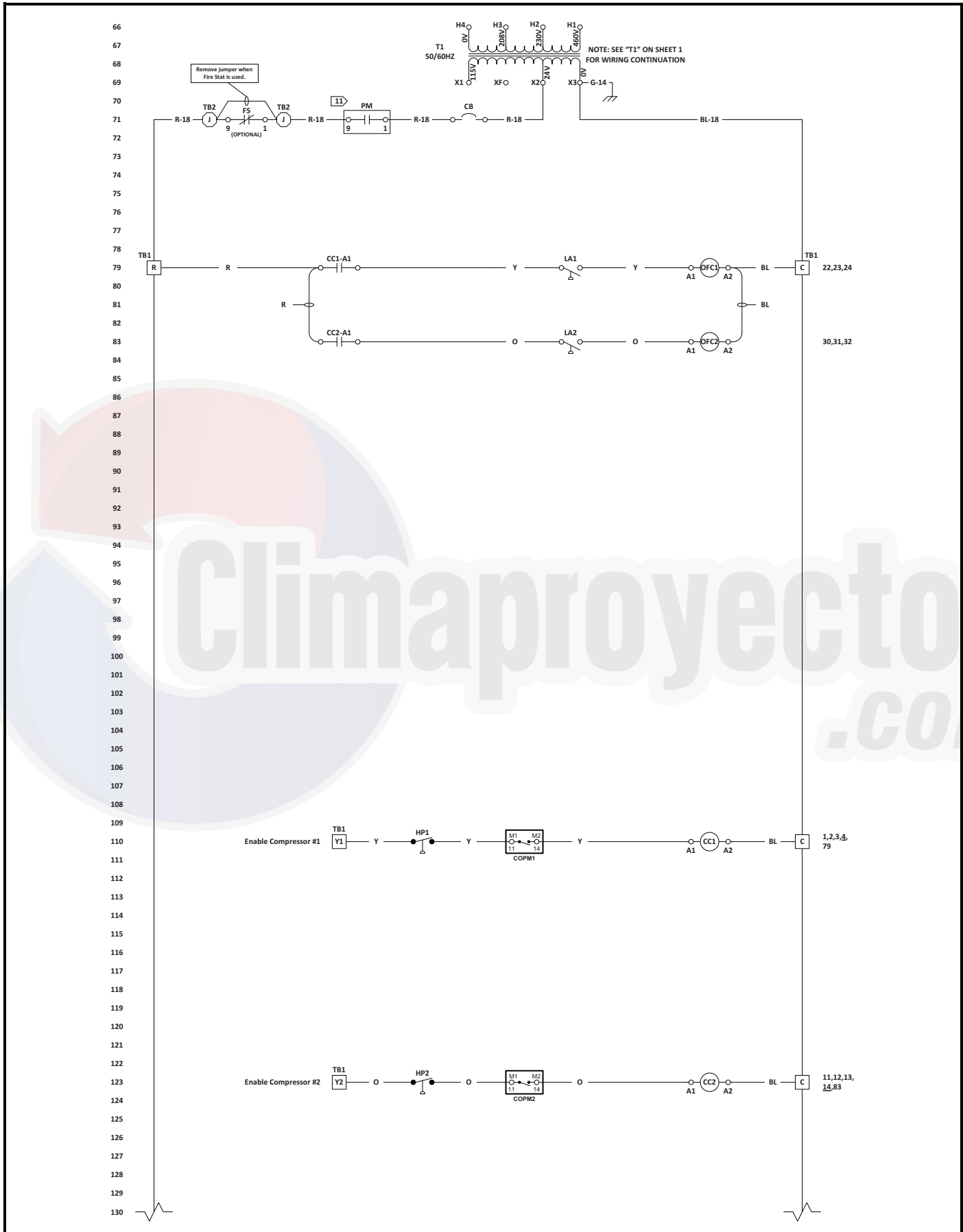

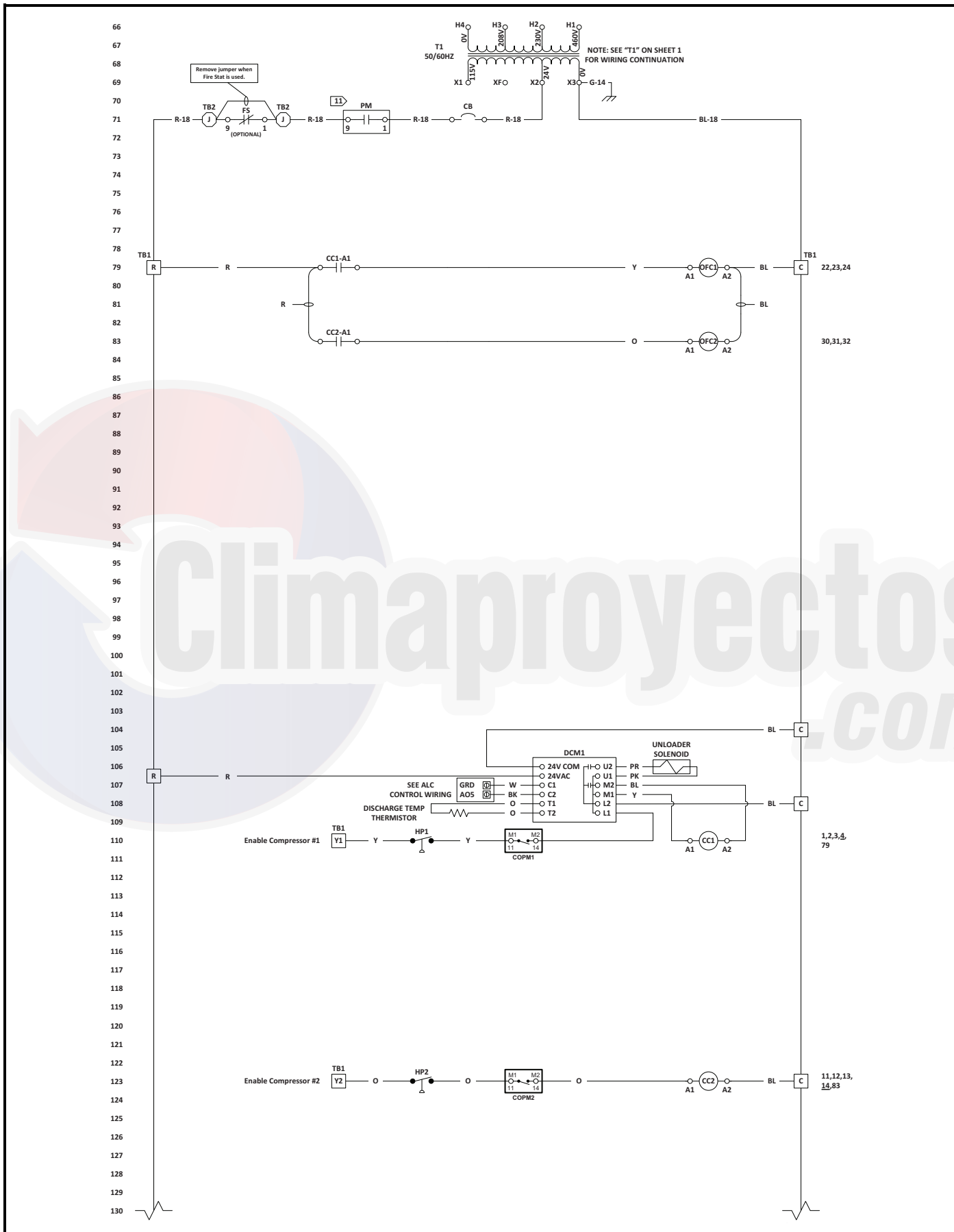

Typical wiring schematics (cont)

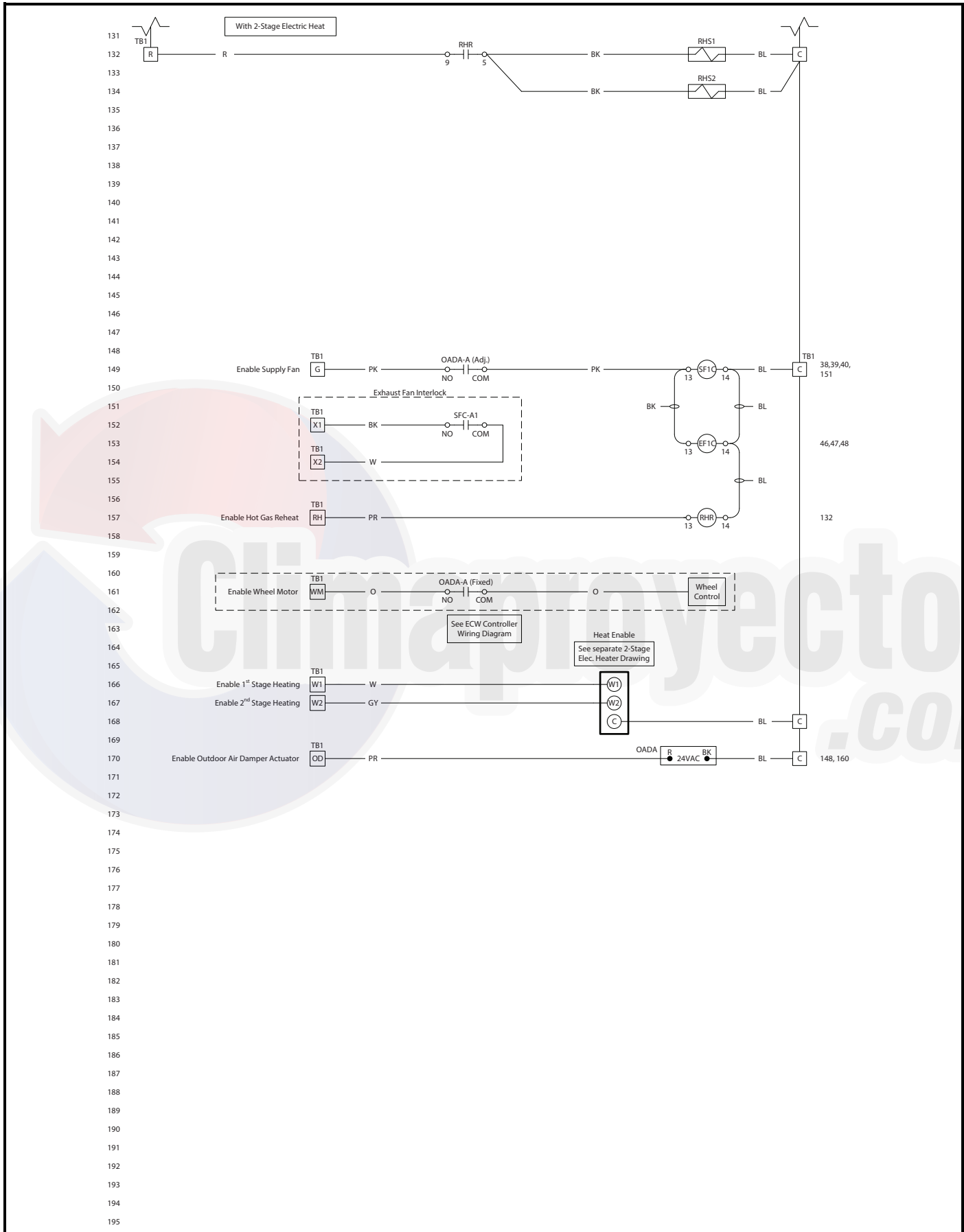

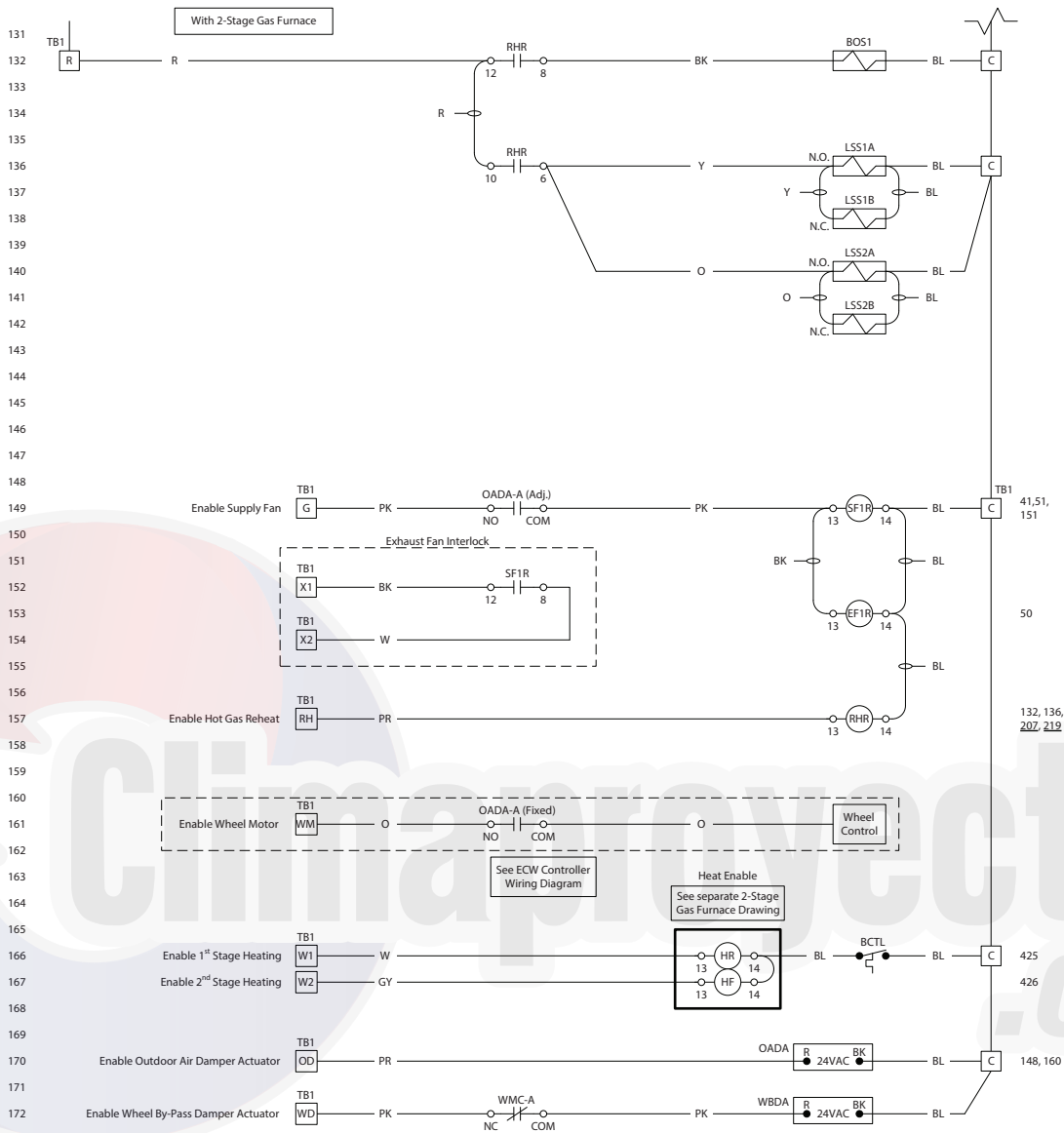

Typical wiring schematics (cont)

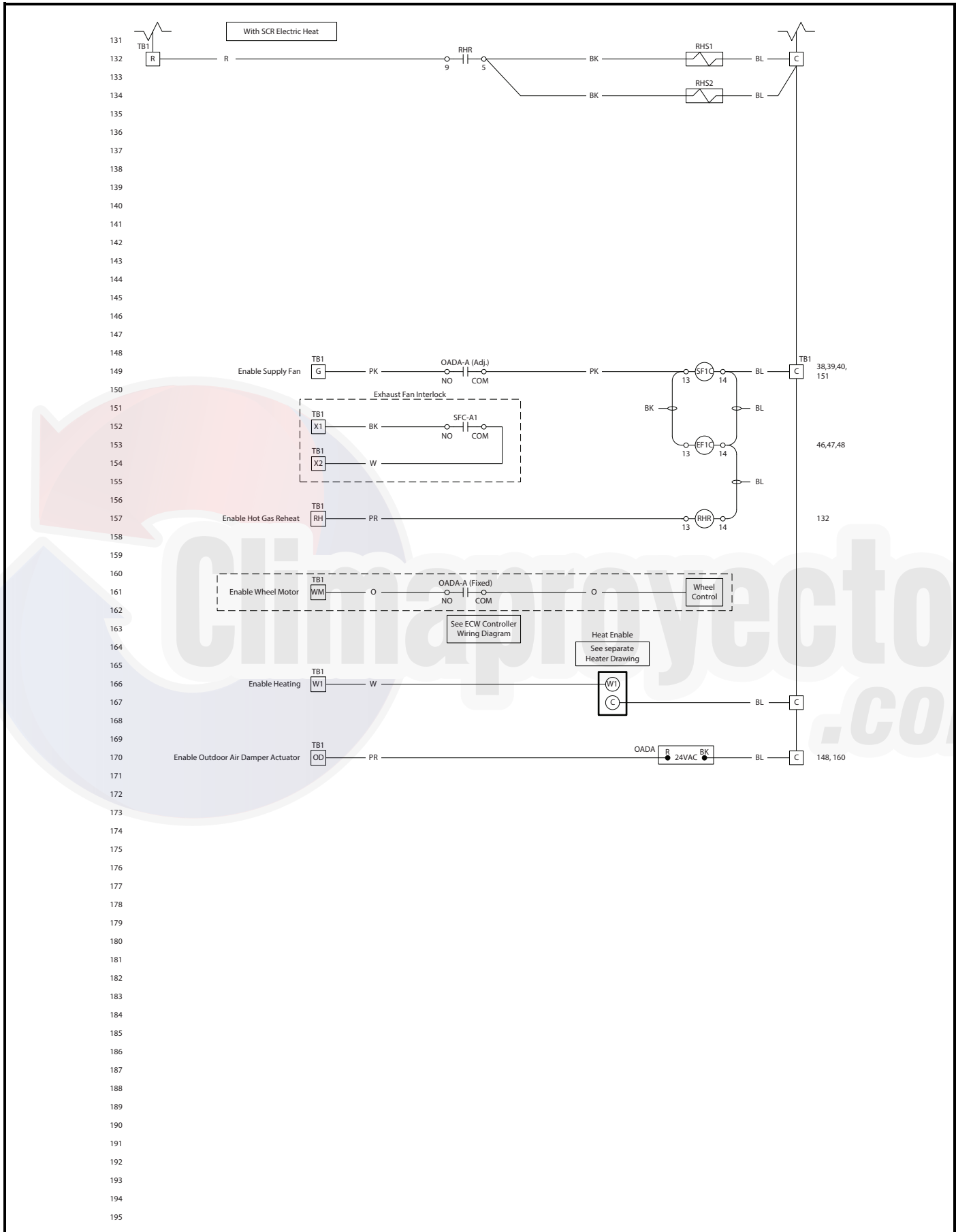

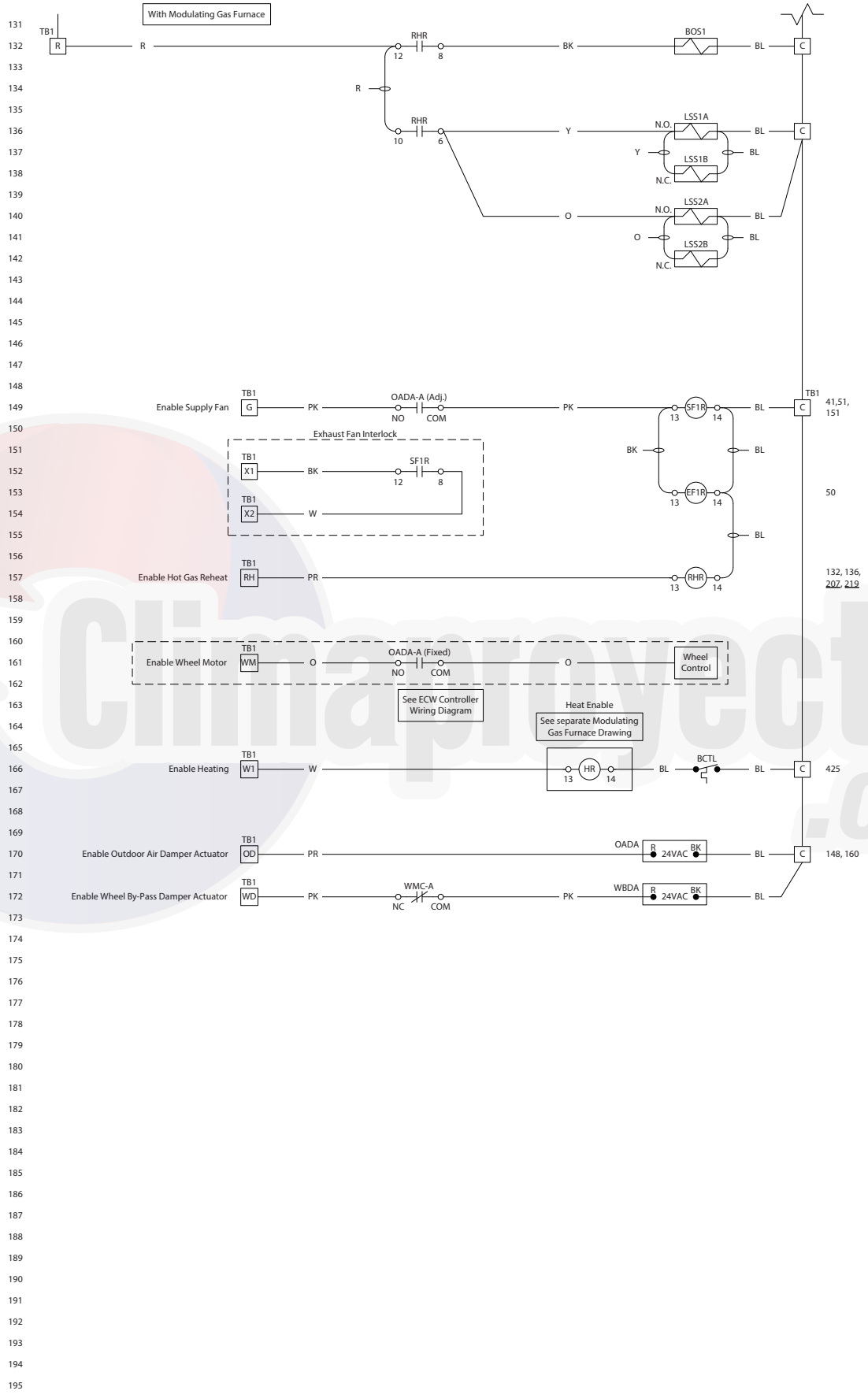

196
197
198
199
200
201
202
203
204
205
206
207
208
209
210
211
212
213
214
215
216
217
218
219
220
221
222
223
224
225
226
227
228
229
230
231
232
233
234
235
236
237
238
239
240
241
242
243
244
245
246
247
248
249
250
251
252
253
254
255
256
257
258
259
260

WIRING DIAGRAM FOR MODULATING REHEAT, 0-10VDC

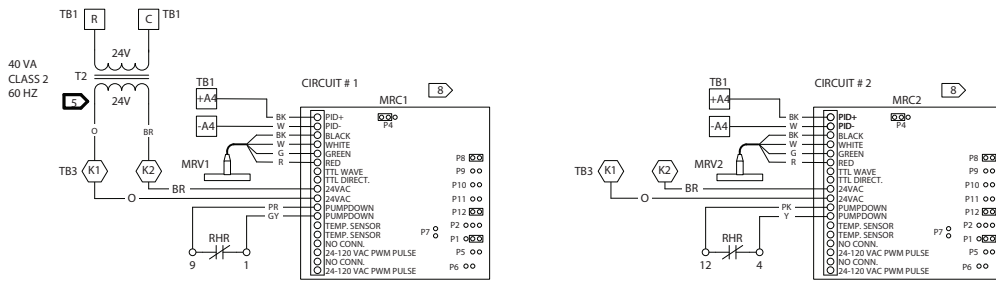

MODULATING DISCHARGE VALVE CONTROL BOARD

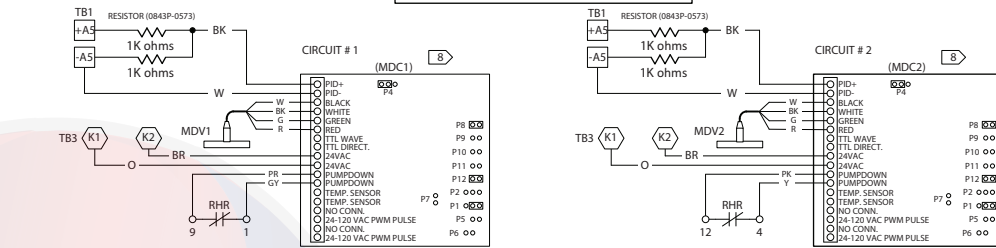

NOTE: BE SURE TO WIRE THE MODULATING DISCHARGE VALVE (MDV) CORRECTLY PER WIRING DIAGRAM. SEE COLOR CODING, THE WHITE WIRE IS CONNECTED TO BLACK AND THE BLACK WIRE IS CONNECTED TO WHITE.

WIRING DIAGRAM FOR 4-STAGE GAS FURNACE

Calibration and Setup

- Set the INPUT RANGE jumper to the correct position for the signal to be used (0-15V).
- Set the deadband jumper to the desired value (3%). This can be changed at any time with the power on.
- Connect the power supply and the input signal to the correct terminals.
- Turn on the power and the POWER LED will light.
- Apply an input signal equal to the R1 setpoint (2.5V).
- Adjust the R1 pot clockwise until the RELAY1 LED goes out, then slowly adjust the R1 pot counterclockwise until the LED just lights.
- Apply an input signal equal to the R2 setpoint (5V) and adjust the R2 pot the same as for R1, watching the RELAY2 LED.
- Adjust R3 (7.5V) and R4 (9.5V) using the same method.
- Test the operation by increasing the input signal and watch as R1 to R4 turn on at the selected setpoints. Then decrease the signal and watch as the relays turn off at the selected setpoints minus the deadband.

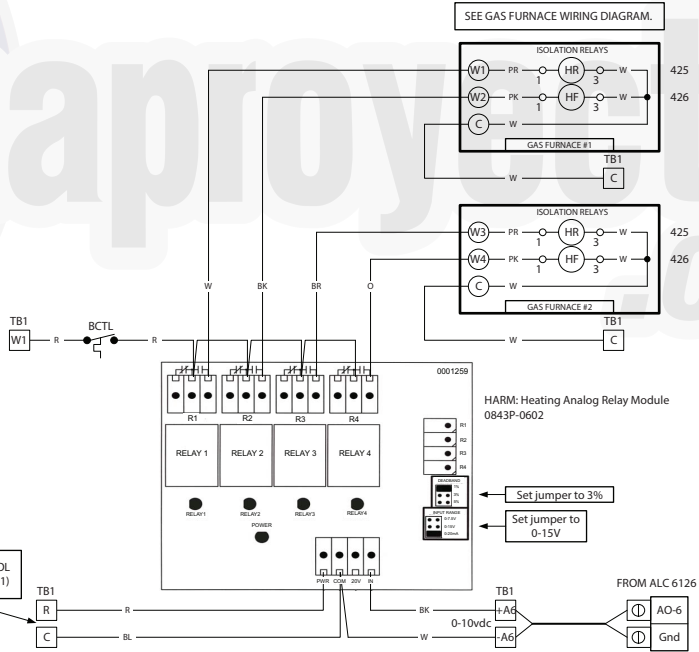

Typical wiring schematics (cont)

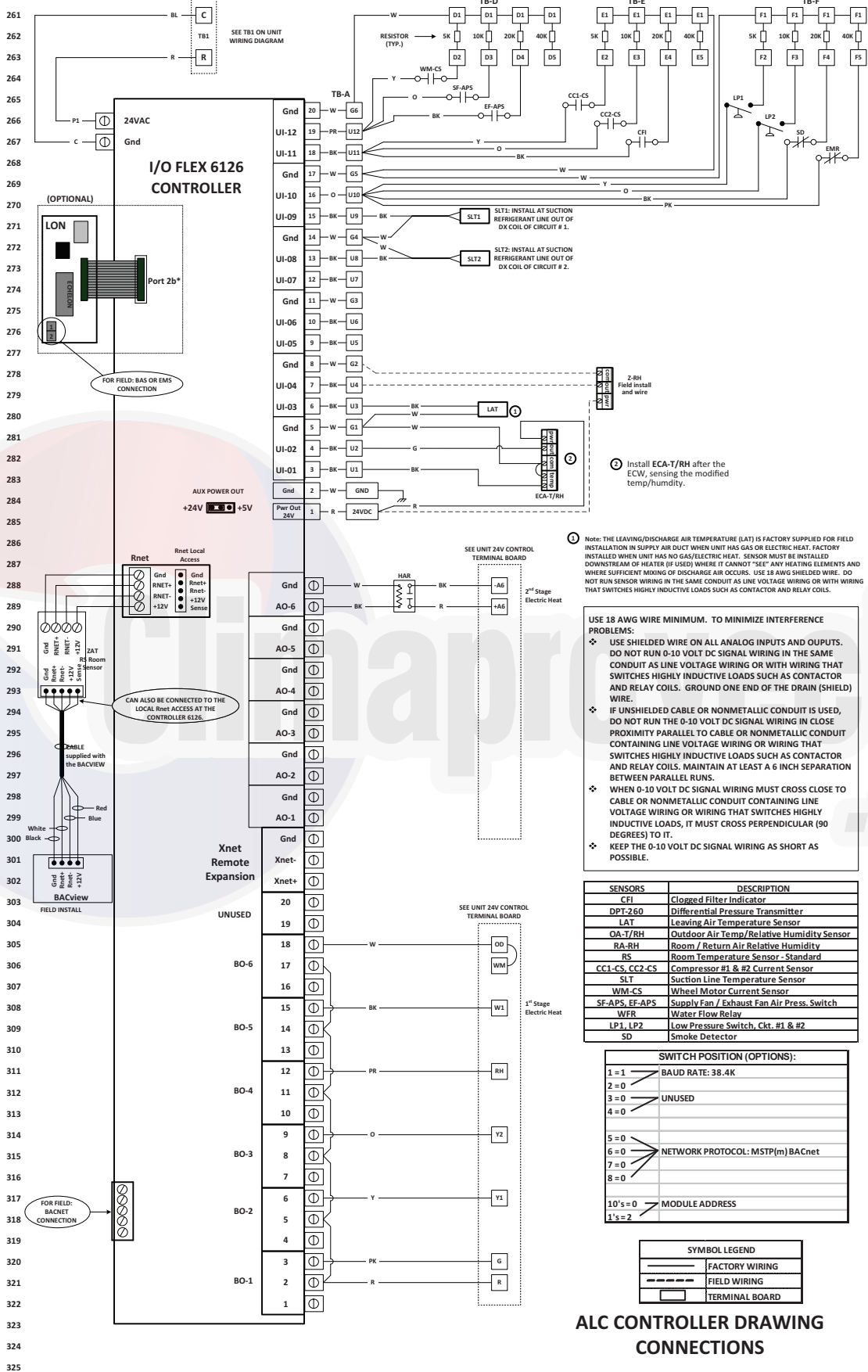

Note: THE LEAVING/DISCHARGE AIR TEMPERATURE (LAT) IS FACTORY SUPPLIED FOR FIELD INSTALLATION IN SUPPLY AIR DUCT WHEN UNIT HAS GAS OR ELECTRIC HEAT. FACTORY INSTALLED WHEN UNIT HAS NO GAS/ELECTRIC HEAT. SENSOR MUST BE INSTALLED DOWNSTREAM OF HEATER (IF USED) WHERE IT CANNOT "SEE" ANY HEATING ELEMENTS AND WHERE SUFFICIENT MIXING OF DISCHARGE AIR OCCURS. USE 18 AWG SHIELDED WIRE. DO NOT RUN SENSOR WIRING IN THE SAME CONDUIT AS LINE VOLTAGE WIRING OR WITH WIRING THAT SWITCHES HIGHLY INDUCTIVE LOADS SUCH AS CONTACTOR AND RELAY COILS.

- USE 18 AWG WIRE MINIMUM. TO MINIMIZE INTERFERENCE PROBLEMS:
- USE SHIELDED WIRE ON ALL ANALOG INPUTS AND OUTPUTS. DO NOT RUN 0-10 VOLT DC SIGNAL WIRING IN THE SAME CONDUIT AS LINE VOLTAGE WIRING OR WITH WIRING THAT SWITCHES HIGHLY INDUCTIVE LOADS SUCH AS CONTACTOR AND RELAY COILS. GROUND ONE END OF THE DRAIN (SHIELD) WIRE.
- IF UNSHIELDED CABLE OR NONMETALLIC CONDUIT IS USED, DO NOT RUN THE 0-10 VOLT DC SIGNAL WIRING IN CLOSE PROXIMITY PARALLEL TO CABLE OR NONMETALLIC CONDUIT CONTAINING LINE VOLTAGE WIRING OR WIRING THAT SWITCHES HIGHLY INDUCTIVE LOADS SUCH AS CONTACTOR AND RELAY COILS. MAINTAIN AT LEAST A 6 INCH SEPARATION BETWEEN PARALLEL RUNS.
- WHEN 0-10 VOLT DC SIGNAL WIRING MUST CROSS CLOSE TO CABLE OR NONMETALLIC CONDUIT CONTAINING LINE VOLTAGE WIRING OR WIRING THAT SWITCHES HIGHLY INDUCTIVE LOADS, IT MUST CROSS PERPENDICULAR (90 DEGREES) TO IT.
- KEEP THE 0-10 VOLT DC SIGNAL WIRING AS SHORT AS POSSIBLE.

SENSORS	DESCRIPTION
CFI	Clogged Filter Indicator
DPT-260	Differential Pressure Transmitter
LAT	Leaving Air Temperature Sensor
OA-T/RH	Outdoor Air Temp/Relative Humidity Sensor
RA-RH	Room / Return Air Relative Humidity
RS	Room Temperature Sensor - Standard
CC1-CS, CC2-CS	Compressor #1 & #2 Current Sensor
SLT	Suction Line Temperature Sensor
WM-CS	Wheel Motor Current Sensor
SF-APS, EF-APS	Supply Fan / Exhaust Fan Air Press. Switch
WFR	Water Flow Relay
LP1, LP2	Low Pressure Switch, Ckt. #1 & #2
SD	Smoke Detector

SWITCH POSITION (OPTIONS):	
1 = 1	BAUD RATE: 38.4K
2 = 0	
3 = 0	UNUSED
4 = 0	
5 = 0	NETWORK PROTOCOL: MSTP(m) BACnet
6 = 0	
7 = 0	
8 = 0	
10's = 0	MODULE ADDRESS
1's = 2	

SYMBOL LEGEND	
	FACTORY WIRING
	FIELD WIRING
	TERMINAL BOARD

ALC CONTROLLER DRAWING CONNECTIONS

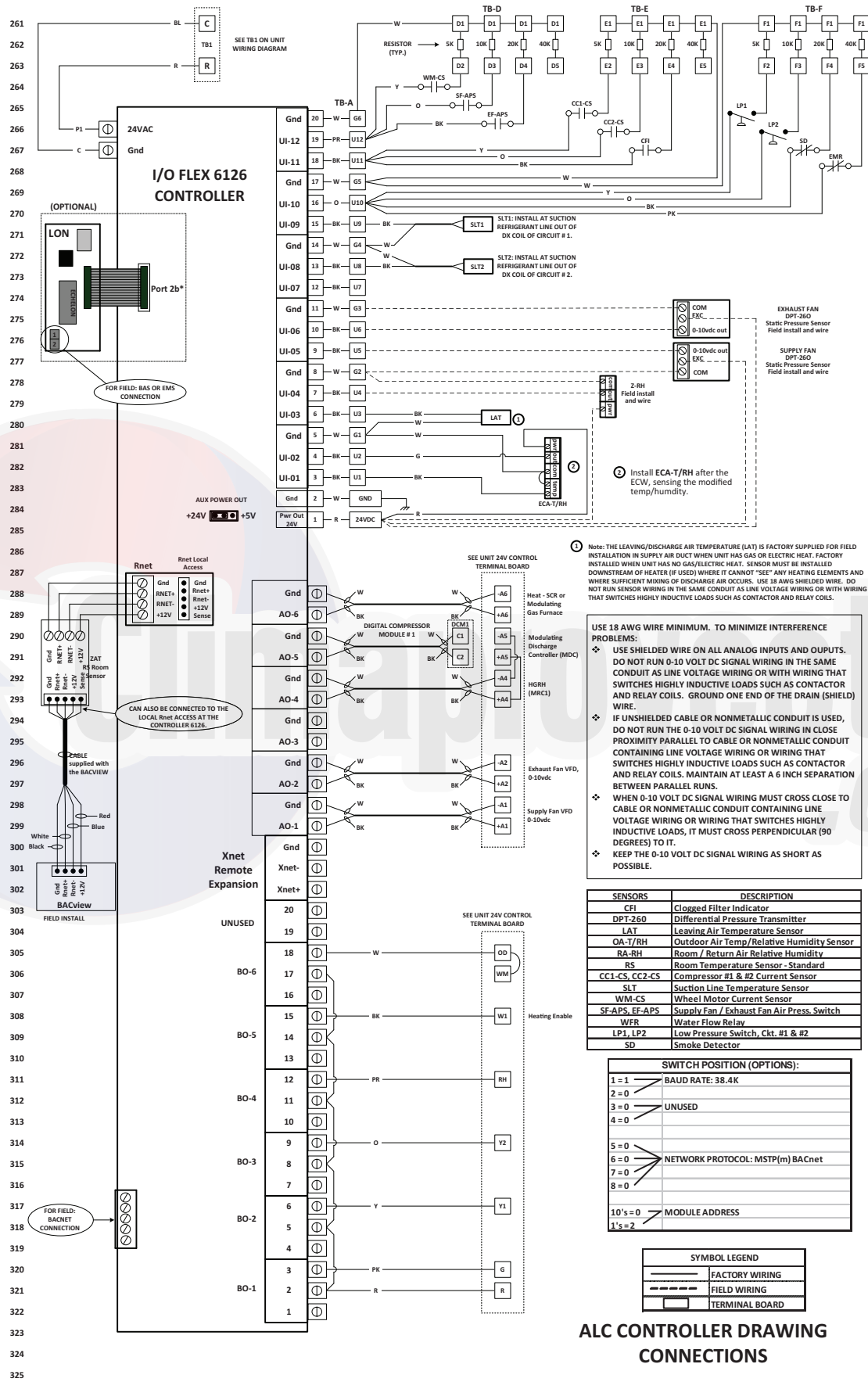

Note: THE LEAVING/DISCHARGE AIR TEMPERATURE (LAT) IS FACTORY SUPPLIED FOR FIELD INSTALLATION IN SUPPLY AIR DUCT WHEN UNIT HAS GAS OR ELECTRIC HEAT. FACTORY INSTALLED WHEN UNIT HAS NO GAS/ELECTRIC HEAT. SENSOR MUST BE INSTALLED DOWNSTREAM OF HEATER (IF USED) WHERE IT CANNOT "SEE" ANY HEATING ELEMENTS AND WHERE SUFFICIENT MIXING OF DISCHARGE AIR OCCURS. USE 18 AWG SHIELDED WIRE. DO NOT RUN SENSOR WIRING IN THE SAME CONDUIT AS LINE VOLTAGE WIRING OR WITH WIRING THAT SWITCHES HIGHLY INDUCTIVE LOADS SUCH AS CONTACTOR AND RELAY COILS.

USE 18 AWG WIRE MINIMUM. TO MINIMIZE INTERFERENCE PROBLEMS:

- USE SHIELDED WIRE ON ALL ANALOG INPUTS AND OUTPUTS. DO NOT RUN 0-10 VOLT DC SIGNAL WIRING IN THE SAME CONDUIT AS LINE VOLTAGE WIRING OR WITH WIRING THAT SWITCHES HIGHLY INDUCTIVE LOADS SUCH AS CONTACTOR AND RELAY COILS. GROUND ONE END OF THE DRAIN (SHIELD) WIRE.
- IF UNSHIELDED CABLE OR NONMETALLIC CONDUIT IS USED, DO NOT RUN THE 0-10 VOLT DC SIGNAL WIRING IN CLOSE PROXIMITY PARALLEL TO CABLE OR NONMETALLIC CONDUIT CONTAINING LINE VOLTAGE WIRING OR WIRING THAT SWITCHES HIGHLY INDUCTIVE LOADS SUCH AS CONTACTOR AND RELAY COILS. MAINTAIN AT LEAST A 6 INCH SEPARATION BETWEEN PARALLEL RUNS.
- WHEN 0-10 VOLT DC SIGNAL WIRING MUST CROSS CLOSE TO CABLE OR NONMETALLIC CONDUIT CONTAINING LINE VOLTAGE WIRING OR WIRING THAT SWITCHES HIGHLY INDUCTIVE LOADS, IT MUST CROSS PERPENDICULAR (90 DEGREES) TO IT.
- KEEP THE 0-10 VOLT DC SIGNAL WIRING AS SHORT AS POSSIBLE.

SENSORS	DESCRIPTION
CFI	Clogged Filter Indicator
DPT-260	Differential Pressure Transmitter
LAT	Leaving Air Temperature Sensor
OA-T/RH	Outdoor Air Temp/Relative Humidity Sensor
RA-RH	Room / Return Air Relative Humidity
RS	Room Temperature Sensor - Standard
CC1-CS, CC2-CS	Compressor #1 & #2 Current Sensor
SLT	Suction Line Temperature Sensor
WM-CS	Wheel Motor Current Sensor
SF-APS, EF-APS	Supply Fan / Exhaust Fan Air Press. Switch
WFR	Water Flow Relay
LP1, LP2	Low Pressure Switch, Ckt. #1 & #2
SD	Smoke Detector

SWITCH POSITION (OPTIONS):	
1 = 1	BAUD RATE: 38.4K
2 = 0	
3 = 0	UNUSED
4 = 0	
5 = 0	
6 = 0	NETWORK PROTOCOL: MSTP(m) BACnet
7 = 0	
8 = 0	
10's = 0	MODULE ADDRESS
1's = 2	

SYMBOL LEGEND	
	FACTORY WIRING
	FIELD WIRING
	TERMINAL BOARD

ALC CONTROLLER DRAWING CONNECTIONS

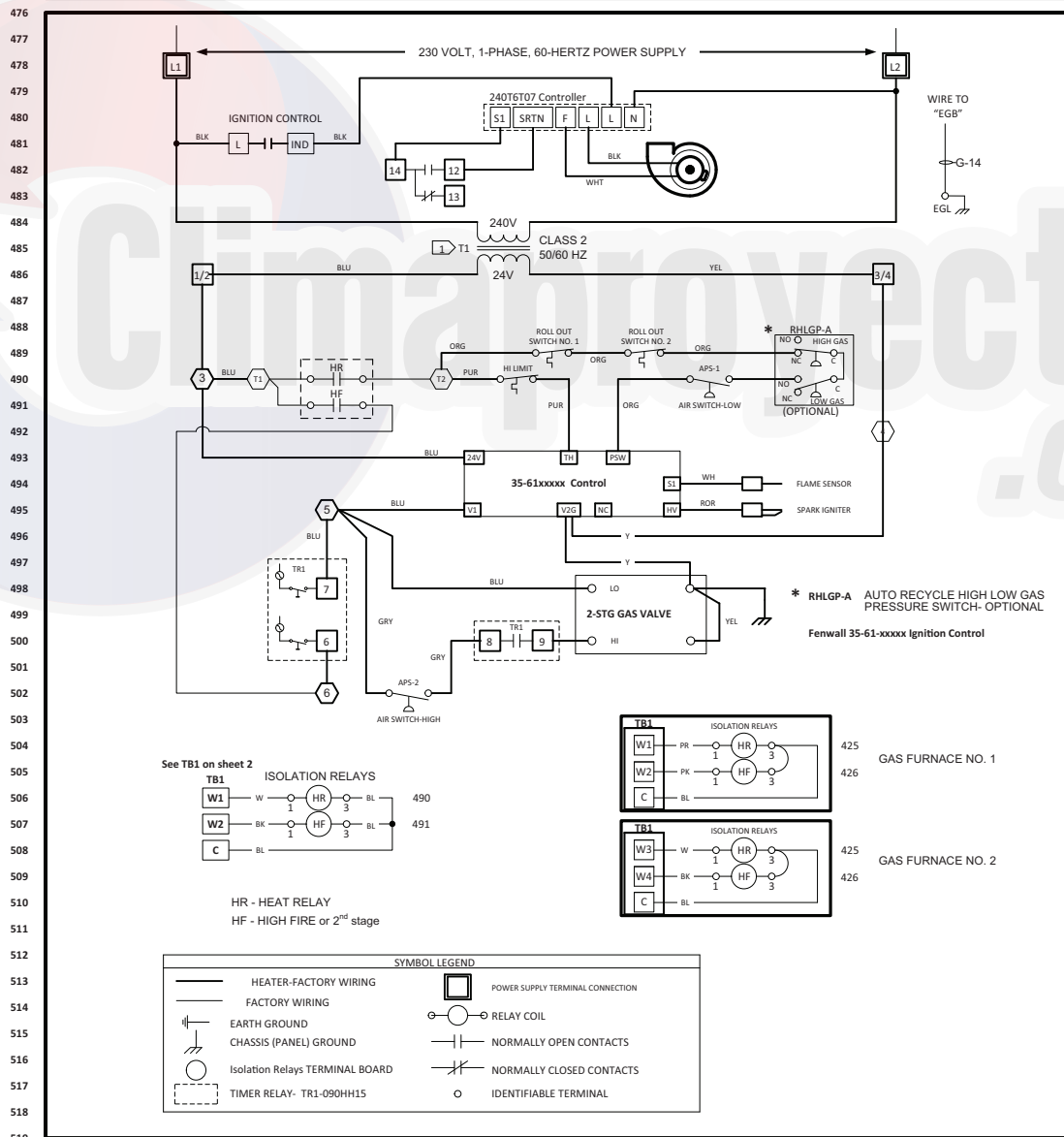
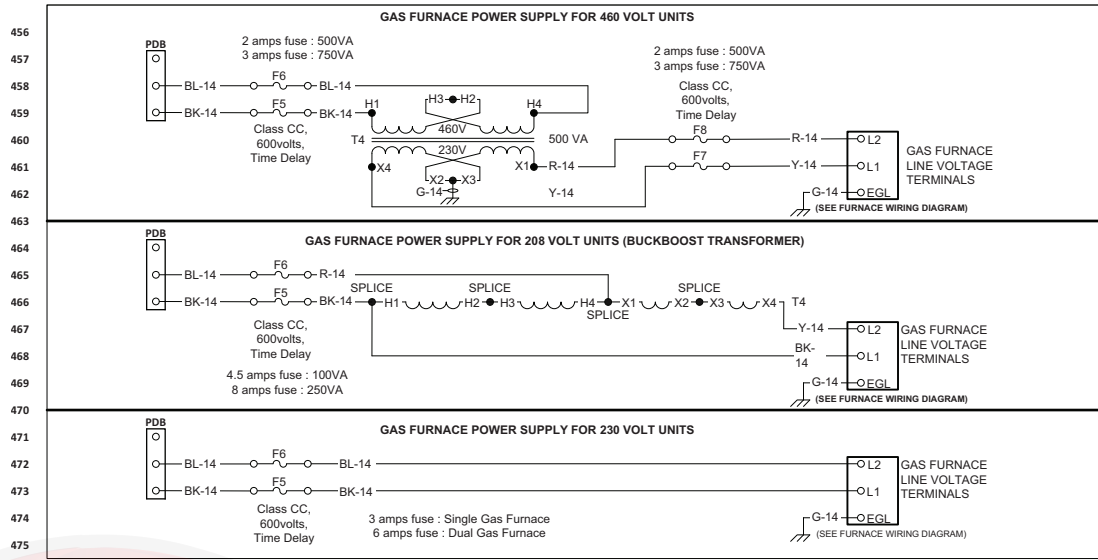

Typical wiring schematics (cont)

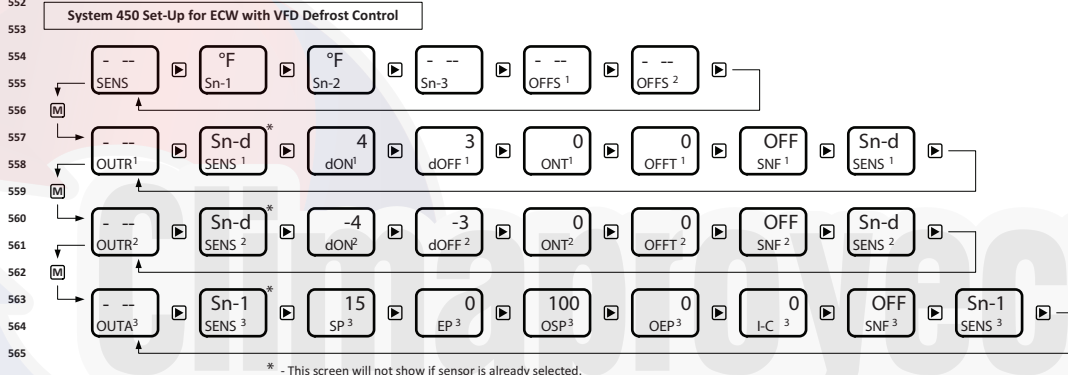
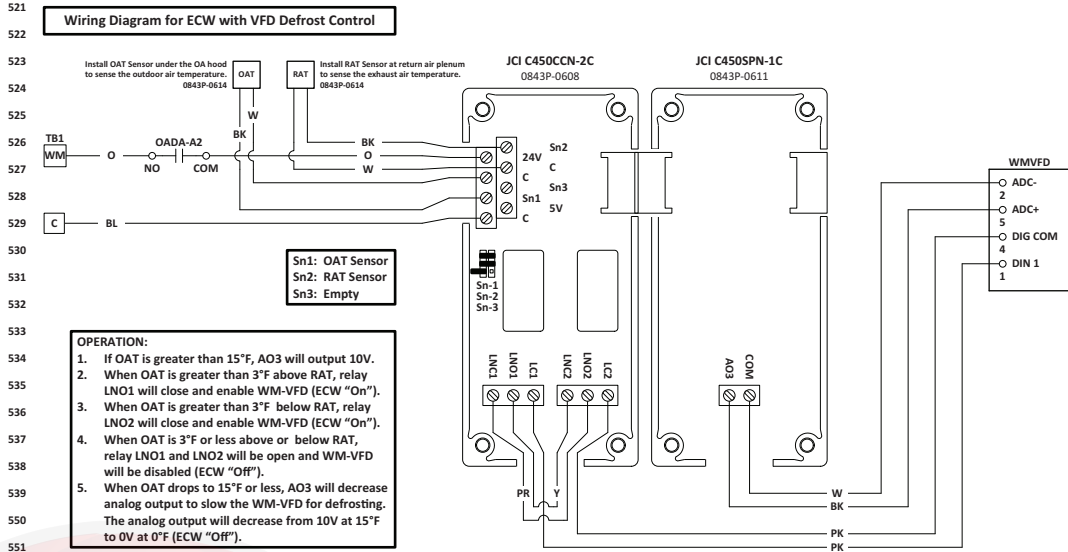

- System 450 Controller Programming Instructions:**
- Jumper on both pins for Sn-1 and Sn-2. Apply 24VAC power.
 - Press and hold **▲** and **▼** simultaneously for 5 seconds to access "SENS" set-up screens.
 - Press **▶** for "Sn-1". Use **▲** or **▼** to select "F" sensor. Press **▶** for "Sn-2". Use **▲** or **▼** to select "F" sensor. Press **▶** then press **M**. Press **M** to access "OUTR¹" set-up.
 - Press **▶** for "SENS¹". Press **▲** or **▼** to set value to "Sn-d".
 - Press **▶** for "dON¹". Press **▲** or **▼** to set value to "4".
 - Press **▶** for "dOFF¹". Press **▲** or **▼** to set value to "3".
 - Press **▶** for "ONT¹". Press **▲** or **▼** to set value to "0".
 - Press **▶** for "OFFT¹". Press **▲** or **▼** to set value to "0".
 - Press **▶** for "SNF¹". Press **▲** or **▼** to set value to "OFF".
 - Press **▶** for "SENS¹". Press **▲** or **▼** to set value to "Sn-d".
 - Press **M** to return to "OUTR¹" screen.
 - Press **M** to access "OUTR²" set-up.
 - Repeat steps 5 thru 11 for "OUTR²" settings except use "-4" for "dON²" and "-3" for "dOFF²".
 - Press **M** to return to "OUTR²" screen.
 - Press **M** to access "OUTA³" set-up.
 - Press **▶** for "SENS³". Press **▲** or **▼** to set value to "Sn-1".
 - Press **▶** for "SP³". Press **▲** or **▼** to set value to "15".
 - Press **▶** for "EP³". Press **▲** or **▼** to set value to "0".
 - Press **▶** for "OSP³". Press **▲** or **▼** to set value to "100".
 - Press **▶** for "OEP³". Press **▲** or **▼** to set value to "0".
 - Press **▶** for "I-C³". Press **▲** or **▼** to set value to "0".
 - Press **▶** for "SNF³". Press **▲** or **▼** to set value to "OFF".
 - Press **▶** for "SENS³". Press **▲** or **▼** to set value to "Sn-1".
 - Press **M** to return to "OUTA³" screen.
 - Press **▲** and **▼** simultaneously to return to the main screen. The controller is now programmed and ready to use.
- * - This screen will not show if sensor is already selected.

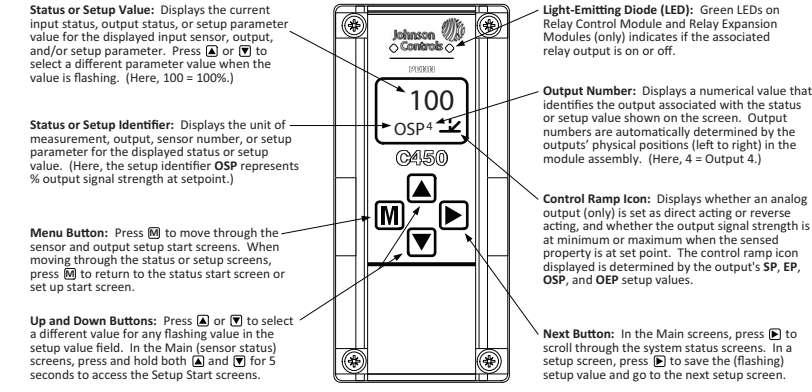

LEGEND FOR TYPICAL WIRING SCHEMATICS

APS	— Supply Air Differential Pressure Switch	MDC	— Modulating Discharge - Line Controller
BCTL	— Blower Compartment High Temperature Limit	MDV	— Modulating Discharge Valve
BOS1	— Bleed off Solenoid #1 for HGRH	MRC	— Modulating Reheat Temperature Control Board
C450	— Johnson Control C450	MRV	— Modulating Hot Gas Reheat Valve
CB	— Circuit Breaker	MSP-CC	— Motor Starter Protection - Compressor Contactor
CC1	— Compressor Contactor No. 1	MSP-EF	— Exhaust Blower Motor Starter Protector
CC1-A	— Compressor Contactor No. 1 Auxiliary Contact	MSP-OF	— Motor Starter Protection - Outdoor Fan
CC2	— Compressor Contactor No. 2	MSP-SF	— Motor Starter Protection - Supply Fan
CC2-A	— Compressor Contactor No. 2 Auxiliary Contact	MSP-WM	— Motor Starter Protection - Wheel Motor
CCH	— Compressor Crankcase Heater	OADA	— Two Position Outdoor Air Damper Actuator
CM1	— Compressor No. 1	OAT	— Outdoor Air Temperature Sensor
CM2	— Compressor No. 2	OFC	— Outdoor Fan Contactor
COPM	— Compressor Overcurrent Protection Module	OFM	— Outdoor Fan Motor
CS	— Compressor Current Sensor Board	PDB	— Power Distribution Block
DPT-260	— Differential Pressure Transmitter 260	PM	— Power Monitor
ECW	— Energy Conservation Wheel	RAT	— Return Air Temperature Sensor
EFC	— Exhaust Fan Contactor	RHR	— Reheat Relay
EFM	— Exhaust Fan Motor	RHS	— Hot Gas Reheat Solenoid Valve
EFR	— Exhaust Fan Motor Relay	SFC	— Supply Fan Motor Contactor
EFVFD	— Exhaust Fan Variable Frequency Drive	SFM	— Supply Fan Motor
EGB	— Equipment Grounding Bar	SFR	— Supply Fan Motor Relay
F	— Fusing	T	— Control Transformer
HAR	— Heating Analog Relay	TB	— Terminal Board
HARM	— Heating Analog Relay Mode	VFD	— Variable Frequency Drive
HP	— High Pressure Cutout	WBDA	— Wheel Bypass Damper Actuator
LA	— Low Ambient Fan Cycling Control	WMC	— Wheel Motor Contactor
LP	— Low Pressure Cutout	WM	— EC Wheel Motor
LSS	— Liquid Sub-Cooling Solenoid	WMC	— Wheel Motor Contactor

Climaproyectos
.com

Guide specifications



Packaged Rooftop Cooling Unit and Packaged Rooftop Cooling Unit with Heat

HVAC Guide Specifications — Section 62DA,DB,DC,DD

Size Range: **6 to 35 Tons Nominal (Cooling)**

Carrier Model Number: **62DA,DB,DC,DD**

Part 1 — General

1.01 SYSTEM DESCRIPTION:

Outdoor roof curb or slab mounted, electronically controlled, cooling or cooling/heating unit utilizing hermetic scroll compressors with crankcase heaters for cooling duty and gas combustion or electric heaters for heating duty. Units shall discharge supply air vertically or horizontally as shown on contract drawings.

1.02 QUALITY ASSURANCE

- A. Unit shall be designed to conform to ANSI/ASHRAE (American National Standards Institute/American Society of Heating, Refrigerating, and Air-Conditioning Engineers) 15 (latest edition), ASHRAE 62, and UL (Underwriters Laboratories) Standard 1995.
- B. Unit shall be listed by ETL and ETL, Canada as a total package.
- C. Gas heat equipped units shall be designed to conform with ANSI Standard Z21.47 (U.S.A.) / CSA (Canadian Standards Association) Standard 2.3 (Canada), Gas-Fired Central Furnaces.
- D. Roof curb shall be designed to NRCA (National Roofing Contractors Association) criteria per Bulletin B-1986.
- E. Insulation and adhesive shall meet NFPA (National Fire Protection Association) 90A requirements for flame spread and smoke generation.

1.03 DELIVERY, STORAGE AND HANDLING

Unit shall be stored and handled per manufacturer's recommendations.

Part 2 — Products

2.01 EQUIPMENT

A. General:

Factory-assembled, single-piece heating and cooling unit. Contained within the unit enclosure shall be all factory wiring, piping, refrigerant charge (R-410A), operating oil charge, single refrigerant circuit (sizes 07–09) or dual refrigerant circuits (sizes 12–38), microprocessor based control system and associated hardware, and all special features required prior to field start-up.

B. Unit Cabinet:

1. Double wall design, constructed of G-90 galvanized steel, bonderized and pre-coated with a baked enamel finish.
 - a. Top cover shall be 18-gage sheet metal with 1.0-in. thick, 4.0-lb density, closed cell insulation with a 24-gage sheet metal interior liner.

- b. Access panels and doors shall be 20-gage sheet metal with 1.0-in. thick, 4.0-lb density, closed cell insulation with a 24-gage sheet metal interior liner. Access doors shall be equipped with stainless steel hinges and quarter turn, adjustable, cam-action latches.
 - c. Insulation shall have a minimum thermal resistance rating of R7.
 - d. Corner and center posts shall be 16-gage galvanized steel.
 - e. Basepans shall be 16-gage galvanized steel. All openings through the basepan shall have upturned flanges at least 0.5 inches in height.
 - f. Basepans shall be insulated with 0.375-in. thick closed cell foam insulation.
 - g. Compressor rail shall be 12-gage galvanized steel.
 - h. Condensate pan shall be 16-gage stainless steel insulated with closed cell neoprene insulation.
 - i. Base rail shall be 14-gage galvanized steel.
 - j. Fan deck (indoor and outdoor section) shall be 16-gage galvanized steel.
 - k. Roof sections shall be sloped for proper drainage.
2. Unit casing shall be capable of withstanding 500-hour salt spray exposure per ASTM (American Society for Testing and Material) B117 (scribed specimen).
 3. Unit shall have insulated hinged access doors for easy access to the control box and other areas requiring servicing. Each door shall seal against a rubber gasket to help prevent air and water leakage and be equipped to permit ease and safety during servicing.
 4. Interior cabinet surfaces shall be lined with 24 gage galvanized steel.
 5. Unit shall have a factory-installed sloped condensate drain connection fabricated of galvanized steel.
 6. Unit shall be equipped with rigging openings in frame rails to facilitate overhead rigging.
 7. Filters shall be accessible through a hinged access panel.
 8. Unit shall have vinyl-coated security grille to protect the condenser and compressor section.
 9. The outdoor air opening shall have a factory-installed hood with bird screen.

C. Fans:

1. Indoor Supply Fans:

- a. Fans shall be belt driven with single outlet discharge.
- b. Fan shaft bearings shall be of the pillow block type with positive locking collar and be permanently lubricated.

- c. Fans shall be statically and dynamically balanced.
- d. The fan assembly shall be mounted in rubber vibration isolators.
- e. Fan assembly shall be on a slide-out deck that is removable for maintenance and service.

2. Condenser Fans:

- a. Fans shall be direct-driven propeller type only, with corrosion-resistant blades riveted to corrosion-resistant steel supports.
- b. Fans shall discharge air vertically upward and be protected by PVC coated steel wire safety guards.
- c. Fans shall be statically and dynamically balanced.

D. Compressors:

- 1. Fully hermetic, scroll type compressors with overload protection and short cycle protection with minimum on and off timers. Digital compressors are available.
- 2. Factory rubber-in-shear mounted for vibration isolation.
- 3. Reverse rotation protection capability.
- 4. Crankcase heaters shall only be activated during compressor off mode.

E. Coils:

- 1. Standard evaporator coil shall have enhanced surface aluminum plate fins mechanically bonded to six rows of seamless internally grooved copper tubes with all joints brazed.
- 2. Standard condenser coil shall have enhanced surface aluminum plate fins mechanically bonded to seamless internally grooved copper tubes with all joints brazed.
- 3. Coils shall be pressure tested at 650 psig prior to unit assembly; leak tested at 150 psig and undergo final testing at 475 psig.
- 4. Optional coil coatings for corrosion protection shall be available.

F. Refrigeration System Components:

- 1. Unit shall be equipped with single refrigerant circuit (sizes 07–09) or dual refrigerant circuits (sizes 12–38), with each circuit containing:
 - a. Solid core liquid line filter drier.
 - b. Adjustable thermostatic expansion valve accumulators.
 - c. Hot gas bypass shall be standard on all non-digital compressors.
 - d. Gage connection ports.
- 2. 100% outdoor air units shall be equipped with low ambient head pressure control to allow operation down to 35 F.
- 3. Hot Gas Reheat:

A factory-installed hot gas reheat (HGRH) coil shall be available. The HGRH coil shall be

available on the lead circuit only or on both refrigerant circuits. Units with HGRH will have variable speed low ambient head pressure control. Cycling or modulating HGRH shall be available.

4. Liquid Subcooling Reheat:

A factory-installed liquid subcooling reheat (LSRH) shall be available on all unit circuits and shall have cycling control. LSRH shall be used in conjunction with lead circuit HGRH.

G. Filter Section:

Standard filter section shall be supplied with 2-in. thick MERV-8 fiberglass filters.

H. Controls and Safeties:

1. Microprocessor Controls:

- a. Unit shall have a factory installed and programmed microprocessor controller with LED indicators and archive capability.
- b. Shall include a field-installed space temperature sensor with communication port.
- c. Shall be capable of communicating via BACnet, Modbus, N2 or LonWorks protocols.
- d. Shall provide a 5° F temperature difference between cooling and heating set points to meet ASHRAE 90.1, energy standard.
- e. Shall provide an alarm indicator and an audible alarm signal via accessory interface device.
- f. Unit shall display current alarms and log 100 most recent alarms.
- g. Compressor minimum off time (5 minutes) shall be provided.
- h. Shall have a service diagnostic mode.
- i. Unit shall be complete with self-contained low voltage control circuit.
- j. Control interface shall be via accessory device with display and key pad. Accessory controller connection shall be at unit controller and space temperature sensor.
- k. Unit scheduling shall be accomplished by built in scheduling program, occupancy switch, or external BAS.

2. Safeties:

- a. Unit shall incorporate a solid-state compressor lockout which provides optional reset capability at the space thermostat should any of the following safety devices trip and shut off compressor:
 - 1) Compressor lockout protection provided for either internal or external overload.
 - 2) Low-pressure protection.
 - 3) Freeze protection (evaporator coil).
 - 4) High-pressure protection.
 - 5) Loss of charge protection.
- b. Supply-air sensor shall be located in the unit and shall be used for compressor stage control.

Guide specifications (cont)



- c. Unit shall be equipped with a supply fan status switch to protect the system in the event of a fan drive failure.
- d. Induced-draft heating section shall be provided with the following minimum protections:
 - 1) High-temperature limit switch.
 - 2) Differential pressure switch to prove induced draft.
 - 3) Flame rollout switch.
 - 4) Flame proving controls.
 - 5) Redundant style gas valve.

I. Operating Characteristics:

- 1. Unit shall be capable of starting and running at 115 F ambient outdoor temperature per maximum load criteria of AHRI (Air-Conditioning, Heating, and Refrigeration Institute) Standard 340/360.
- 2. Unit with standard controls will operate in cooling down to an outdoor ambient temperature of 35 F.
- 3. Unit shall be equipped with a motorized two-position outdoor air (OA) damper for 100% OA operation.
- 4. Unit shall be provided with fan time delay to prevent cold air delivery (gas heat only).

J. Electrical Requirements:

All unit power wiring shall enter unit cabinet at a single location.

K. Motors:

- 1. Compressor motors shall be cooled by refrigerant gas passing through motor windings and shall have either internal line break thermal and current overload protection or external current overload modules with compressor temperature sensors.
- 2. All condenser-fan motors shall be open drip proof with permanently lubricated ball bearings, class F insulation and manual reset overload protection.
- 3. All indoor-fan motors 1 hp and larger shall meet the minimum efficiency requirements as established by the Energy Independence and Security Act of 2007 (EISA), effective December 20, 2010.
- 4. All indoor-fan motors shall be open drip proof design.

L. Special Features:

Not all feature combinations are available. Contact your local Carrier Sales Office.

1. Energy Recovery:

- a. The factory-installed enthalpy wheel shall be certified to meet the requirements of AHRI Standard 1060 and shall be AHRI listed.
- b. The enthalpy wheel shall be constructed of corrugated synthetic fibrous media with a

desiccant intimately bound and uniformly and permanently dispersed throughout the matrix structure of the media.

- c. The desiccant material shall be molecular sieve, 4 angstrom or smaller.
- d. The rotor shall be constructed of alternating layers of flat and corrugated media.
- e. Wheel construction shall be fluted or formed honeycomb geometry so as to eliminate internal wheel bypass.
- f. The wheel frames shall be evenly spaced steel spokes with a galvanized steel outer band and rigid center hub.
- g. The wheel seals shall be full contact nylon brush type.
- h. The wheel shall slide out of the cabinet side for service.
- i. Wheel cassettes shall be constructed of galvanized steel. Cassettes shall have integral purge section.
- j. The wheel bearings shall be inboard mounted, permanently sealed roller bearings or externally flanged bearings.
- k. The wheel shall be driven by a fractional horsepower AC motor via multilink drive belts.

- l. Energy wheel defrost control and air bypass shall be available.

2. Gas Heating:

- a. Gas heat shall be induced-draft combustion type with energy saving direct spark ignition systems and redundant main gas valves.
- b. The heat exchanger shall be of the tubular section type constructed of a minimum of 20-gage stainless steel.
- c. Burners shall be of the in-shot type constructed of aluminum coated steel.
- d. All gas piping shall enter the unit cabinet at a single location.

e. Induced-Draft Fans:

- 1) Shall be direct-driven, single inlet, forward-curved centrifugal type.
- 2) Shall be statically and dynamically balanced.
- 3) Shall be made from steel with a corrosion-resistant finish.
- f. High-corrosion areas such as flue gas collection and exhaust areas shall be lined with corrosion resistant material.
- g. Optional 5:1 or 10:1 turndown modulating furnace shall be available.

3. Electric Heat:

- a. Electric resistance heaters shall be factory-installed, nichrome element type, open wire coils with 0.375 in. inside diameter, insulated with ceramic bushings, and include operating

- and safety controls. Coil ends shall be staked and welded to terminal screw slots.
- b. Factory-installed electric heat shall have staged heat control (1, 2, 3, or 4 stages) or SCR (silicon controlled rectifier) control providing infinite capacity adjustment.
4. Hot Water Heat:

Unit shall have a 2-row hot water coil, aluminum construction, with air vents installed downstream of the evaporator coil. Coil connection stubs will be located inside the unit cabinet. Hydronic control valves shall be field furnished.
 5. Steam Heat:

Unit shall have 1-row, steam distributing type, aluminum fin coil installed downstream of the evaporator coil. Coil connection stubs will be located inside the unit cabinet. Control valves to be field furnished.
 6. Supply Fan:

Supply fan of the backward curve, forward curve, airfoil, or backward inclined type shall be factory-installed, mounted on rubber isolation, and installed on a slide-out deck that is removable for maintenance and service.
 7. Modulating Supply Fan:

Package shall include a VFD-controlled supply fan mounted on rubber vibration isolation and installed on a slide-out deck that is removable for maintenance and service. VFD control shall be based on duct pressure.
 8. Liquid Subcooling Coil:

The unit shall be equipped with a factory-installed full face liquid subcooling coil on all circuits.
 9. Exhaust Fan:

Package shall include an exhaust fan of the backward curve, forward curve, or airfoil type mounted on rubber vibration isolation with gravity relief damper. The shaft-mounted fan shall be mounted in sealed ball bearings and driven via an adjustable sheave belt drive.
 10. Modulating Exhaust Fan:

Package shall include a VFD controlled exhaust fan mounted on rubber vibration isolation with gravity relief damper. The shaft-mounted fan is mounted in sealed ball bearings and driven via an adjustable sheave belt drive. Control shall be based on building pressure.
 11. Oversize Fan Motors:

Oversize fan motors shall be available for both optional supply and exhaust fan motors.
 12. Liquefied Propane Conversion Kit:

Kit shall contain all the necessary hardware and instructions to convert a standard natural gas unit for use with liquefied propane gas.
 13. Convenience Outlet:

Shall be factory-installed and internally mounted with an externally accessible 115-v, 15 amp GFI, female receptacle with hinged cover. The outlet shall require field-supplied 115-v power supply wiring.
 14. Fused Disconnect Switch:

Shall be factory-installed, internally mounted, and UL approved. Fused switch shall provide unit power shutoff. Shall be accessible from outside the unit and shall provide power off lockout capability.
 15. Firestat:

A factory-installed, manual-reset firestat shall be mounted in the return-air opening of the unit. The firestat shall be set to open at 135 F.
 16. Exhaust Air Smoke Detector:

A factory-installed smoke detector shall be mounted in the unit exhaust air intake (62DC,DD).
 17. Dirty Filter Status Switch:

The manual reset filter status switch shall be a pressure differential switch and will indicate a dirty filter. The switch shall be factory installed.
 18. Fan Status Switch:

The unit shall be equipped with a field-adjustable differential air pressure switch installed across the filters or supply fan to provide proof of airflow.
 19. Phase/Voltage Monitor:

A factory-installed under-voltage and phase loss sensor shall stop the unit whenever voltage is too low, phases are out of sequence, or a phase is dropped. The unit will restart automatically within five minutes after the correct power is supplied.
 20. Spring Fan Isolation:

Supply fan and power exhaust fan (if equipped) shall be mounted in spring type isolation with seismic restraints.
 21. 4-Inch Filters:

Optional filter section shall be supplied with 4-in. thick MERV-8 or 11 pleated fiberglass filters.
 22. Filter Kits:

Accessory filter kits shall be available with MERV-8 or 11 type filters.
 23. Digital Compressor:

A digital compressor shall be available. The control system shall be capable of unloading the compressor in an unlimited number of steps from 100% capacity down to 10% capacity.
 24. Commissioning User Interface:

The commissioning keypad/display unit shall have a numeric keypad, direction keys, and

Guide specifications (cont)



programmable function keys. The display shall be a 4-line by 40-character backlit LCD display.

25. Head Pressure Control:

Condenser fan cycling or variable speed condenser fans shall be available for head pressure control.

26. LonWorks Communicator:

LonWorks communication shall be available factory installed.

27. Roof Curb:

Curb shall be formed of 14-gage galvanized steel with wood nailer strip and shall be capable of supporting entire unit weight.

28. Minimum Load Valve:

Unit shall be equipped with factory-installed minimum load valve (hot gas bypass).

29. Harsh Environment Coating:

Unit shall be equipped with a factory-applied "Harsh Environment Protection" designed to combat the corrosive effects of industrial and commercial atmospheric conditions including: salt air, salt water, acid rain, chlorine and chlorides, hydrochloric, nitric, hydrofluoric, sulfuric and uric acid fumes, hydrogen sulfide gas, lye, sulfur dioxide, methane gas, hydrocarbons, chlorinated solvents and aromatic solvents. The Harsh Environment Protection shall include the following features, where applicable, to provide extra protection against corrosive atmospheric conditions:

- a. Vinyl-coated condenser fan guards.
- b. Non-corroding condenser fan motor mounts.

- c. Totally enclosed single-speed three-phase condenser fan motors.
- d. Coated refrigerant to air condenser with corrosion-resistant coil coating composed of aluminum-impregnated polyurethane, rated for 10,000 hr salt spray.
- e. Coated refrigerant to air evaporator with corrosion-resistant coil coating composed of aluminum-impregnated polyurethane, rated for 10,000 hr salt spray.
- f. Coated refrigerant to air hot gas reheat coil with corrosion-resistant coil coating composed of aluminum-impregnated polyurethane, rated for 10,000 hr salt spray.
- g. Coated refrigerant to air subcooling coil with corrosion-resistant coil coating composed of aluminum-impregnated polyurethane, rated for 10,000 hr salt spray.
- h. All interior (un-insulated) cabinet panels coated with corrosion-resistant cabinet coating composed of polyurethane, rated for 10,000 hr salt spray.
- i. All exterior surfaces of the cabinet coated with corrosion-resistant cabinet coating composed of polyurethane, rated for 10,000 hr salt spray.
- j. All compressors, accumulators, factory-installed receivers, control device covers and refrigerant piping coated with corrosion-resistant cabinet coating composed of polyurethane, rated for 10,000 hr salt spray.

