

WEATHERMAKER®/WEATHERMASTER®

48/50TC 04–16

48/50HC 04–14

HUMIDI-MIZER®

Adaptive Dehumidification System



turn to the experts 

Application Data

TABLE OF CONTENTS

INTRODUCTION	1	SYSTEM SPECIFICATIONS	14
FEATURES/BENEFITS	2	CONTROL WIRING APPLICATIONS	14
Maximum Flexibility	2	Standard Unit	14
Consistent Comfort	2	PremierLink™ Units	14
Superior Humidity Control	2	RTU Open Units	14
Cost Effectiveness	2	ComfortLink Units	14
HUMIDI-MIZER ADAPTIVE DEHUMIDIFICATION SYSTEM DESIGN CONSIDERATIONS	2		
TYPICAL APPLICATIONS	4		
Schools	4		
Restaurants and Fast Food Chains	4		
Health Clubs	4		
Convenience Stores and Supermarkets	4		
Museums and Libraries	4		
Humid Climates	4		
SYSTEM OVERVIEW	4		
Modes of Operation	4		
Normal Design Cooling Operation	5		
Subcooling Mode	5		
Hot Gas Reheat Mode	6		
Rooftop System Performance	6		
SYSTEM SELECTION	7		
Design Example	7		
Peak Dry Bulb	7		
Peak Dew Point	8		
Extremely High Humidity	9		
Economizer Usage	10		
SEQUENCE OF OPERATION	10		
48/50TC Units (Standard Efficiency Units)	11		
48/50HC High Efficiency Units)	12		

INTRODUCTION

Packaged rooftop units are currently being implemented in many expanded applications that require the highest degree of indoor comfort and humidity control. This trend is a direct result of making rooftop packages more cost effective. To fully realize the potential energy-saving benefit of packaged rooftop units an expanded envelope of operation may be required. Maintaining indoor space humidity levels can be increasingly difficult depending on the time of year, location of the installation, and the ability of the equipment to provide reliable, flexible operation to meet indoor part load sensible and latent load requirements. Standard product enhancements cannot always meet these requirements, as the equipment must often inefficiently treat a higher proportion of outdoor air, or waste energy by trying to control humidity levels by overcooling a space.

Carrier's Humidi-MiZer adaptive dehumidification system is an all-inclusive factory-installed option that can be ordered with any WeatherMaker 48/50TC or WeatherMaster 48/50HC rooftop unit to meet the demand for providing a flexible and high performing solution to accommodate all of these design related issues. This system expands the envelope of operation of Carrier's 48/50TC or 48/50HC rooftop products to provide unprecedented flexibility to meet year round comfort conditions. The Humidi-MiZer adaptive dehumidification system has the industry's only dual dehumidification mode setting.

The Humidi-MiZer system includes two new modes of operation. 48/50TC and 48/50HC rooftop units coupled with the Humidi-MiZer system are capable of operating in the following modes:

48-50TCHC-01XA

1. Normal Design Cooling Mode

Normal operation of the rooftop unit sequence to cycle up to two compressors (sizes: TC 08-16, HC 08-14) to maintain comfort conditions. See Fig. 1.

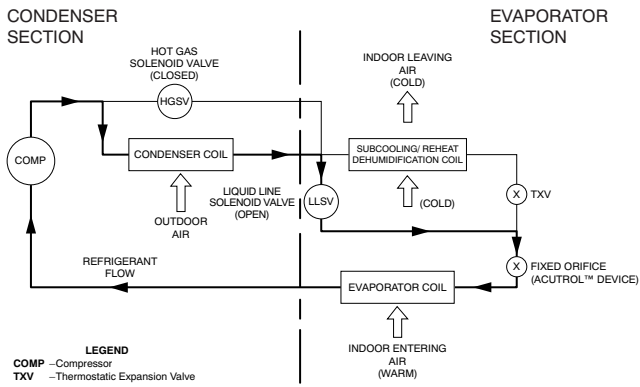

C12715

Fig. 1 - Normal Design Cooling Mode

2. Subcooling Mode

This mode will operate to satisfy part load type conditions when the space requires combined sensible and a higher proportion of latent load control. See Fig. 2.

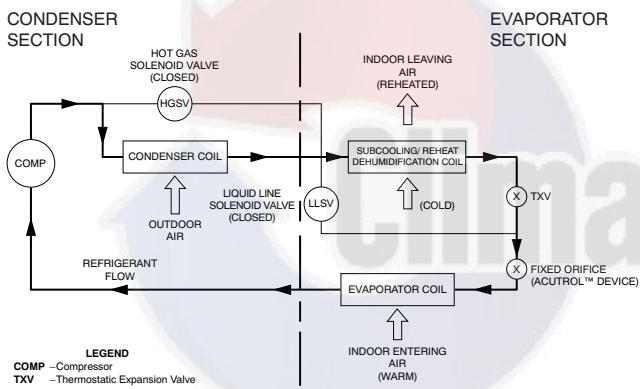

C12716

Fig. 2 - Subcooling Mode

3. Hot Gas Reheat Mode

When outdoor temperatures diminish and the need for latent capacity is required for sole humidity control, hot gas reheat mode will provide neutral air for maximum dehumidification operation. See Fig. 3.

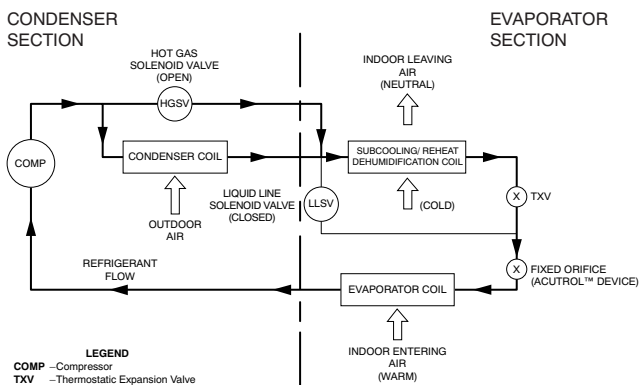

C12717

Fig. 3 - Hot Gas Reheat Mode

FEATURES/BENEFITS

Combined together in one packaged rooftop unit, the Humidi-MiZer[®] adaptive dehumidification system provides the greatest degree of operational flexibility and superior humidity control for consistently maintaining year round indoor comfort temperature and humidity levels. In summary, the Humidi-MiZer adaptive dehumidification system benefits include:

Maximum Flexibility —

Using three operational modes, the system is better able to adapt to all peak and part load outdoor temperature and humidity conditions.

Consistent Comfort —

System flexibility allows the rooftop unit to maintain both indoor temperature and humidity comfort conditions consistently year round.

Superior Humidity Control —

When maximum humidity control is required in the space, Carrier's exclusive hot gas reheat design sequence provides neutral air and subsequent dehumidification of the space.

Cost Effectiveness —

Available as a factory-installed option on the 48/50TC and 48/50HC rooftop product lines, the Humidi-MiZer adaptive dehumidification system provides a cost effective packaged alternative for meeting more latent load intensive applications. System installation costs are simplified and minimized by using Carrier's exclusive Thermidistat or a humidistat device with a thermostat for combined temperature and humidity sensing in the space.

HUMIDI-MIZER ADAPTIVE DEHUMIDIFICATION SYSTEM DESIGN CONSIDERATIONS

To fully understand the benefits of the Humidi-MiZer adaptive dehumidification system, it is necessary to outline some design challenges associated with maintaining appropriate humidity levels and indoor comfort conditions. Many factors can contribute to the need for increased levels of system flexibility and overall humidity control. In addition, maintaining indoor comfort conditions can be increasingly difficult depending on the type of equipment utilized. Design consideration for the selection of air conditioning equipment for maintaining humidity in all types of outdoor and indoor load conditions will depend on the flexibility of the system. Such a system would need to provide airflow volumes that will satisfy varying degrees of sensible and latent loads for both ventilation air and the space. This may be difficult for packaged unitary equipment due to the fixed amount of cfm/ton of capacity (a fixed sensible and latent capacity) that is representative of rooftop units. The Humidi-MiZer adaptive dehumidification option provides a cost effective, flexible solution for meeting more stringent conditioning (and specifically humidity) requirements using the 48/50TC or 48/50HC rooftop product line. The following are some challenges associated with the implications for dehumidification design:

1. Indoor Air Quality:

Humidity is one of the leading factors contributing to the growth and propagation of mold and mildew in a building. Mold and mildew can spread quickly and grow in carpets, ductwork, on and inside walls. Mold and mildew growth inside a space can lead to significant odors and subsequent illness. To maintain indoor humidity levels within an acceptable comfort level range, ANSI/ASHRAE (American National Standards Institute/American Society of Heating, Refrigeration, and Air Conditioning Engineers) Standard 62-2001, Ventilation for Acceptable Indoor Air Quality recommends that indoor relative humidity levels be maintained between 30% and 60% to minimize the growth of allergenic and pathogenic organisms. Maintaining the relative humidity within these limits requires the use of a system that will accommodate both peak and part load conditions. Reducing the potential for mold and mildew propagation on an annual basis will greatly minimize the chance for indoor air quality issues.

2. Occupant Comfort:

One of the greatest challenges in the design of a particular HVAC (heating, ventilation and air conditioning) system is to maintain comfort conditions, especially indoor humidity, for all occupants year round. The challenge becomes increasingly difficult since occupants tend to have different comfort thresholds. ANSI/ASHRAE Standard 55-1992 provides a basis for the limits in which occupants feel comfortable in all seasonal extremes. This standard specifies the indoor conditions that would be acceptable for 80% or more of occupants within a space. This is depicted as the comfort zone as shown in Fig. 4.

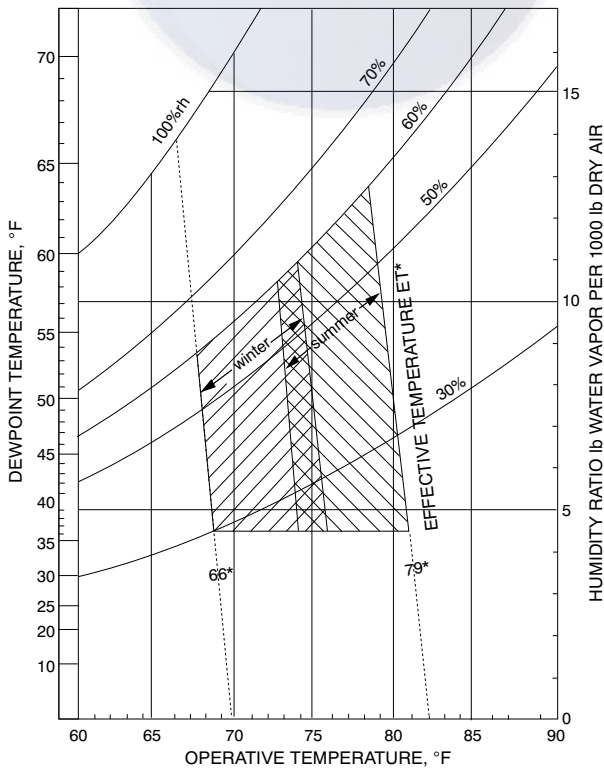

C12718

Fig. 4 - ASHRAE 55-1992 Comfort Zone Definition

3. Outdoor Climate Impact:

Designing an HVAC system to appropriately handle variable sensible and latent loads year round requires consideration of the change in outdoor air conditions, location of the climate, and indoor latent conditions. Higher outdoor temperatures result in higher sensible wall, roof, and solar loads, as well as sensible ventilation load. However, as the outdoor dry bulb temperature diminishes, the outdoor wet bulb temperature may remain the same or be relatively higher. This is especially true on a mild, rainy day. As a result, latent loads (indoor loads from people and latent ventilation load), may remain constant or increase, while sensible loads decrease. Designing for only the peak coincident dry bulb conditions may not appropriately handle humidity during off-peak instances when humidity levels are still high, but the temperature has dropped. In these circumstances, the equipment needs to provide mostly latent capacity, which is difficult when applying packaged rooftops, since the sensible and latent capacities in cfm/ton are constant. Without system enhancements, such as the Humidi-MiZer[®] adaptive dehumidification option, it is not possible to provide only latent capacity.

4. Indoor Latent Loads:

Another very important consideration in the application of appropriate dehumidification equipment is the variability and proportion of latent load in the space. When designing a system, the proportion of sensible to total load in the space is characterized by the sensible heat ratio (SHR). This ratio specifically outlines the sensible and latent heat removal characteristics for the space. For example, a higher SHR indicates a higher relative proportion of sensible load in the space and a lower SHR indicates higher relative proportion of latent load in the space. Since typical packaged rooftop equipment has a fixed cfm/ton sensible and latent capacity, the capability of the equipment to remove the relative proportions of sensible and latent heat from the space is constant. Providing a fixed sensible to total capacity may not always maintain comfort conditions in applications that have higher amounts of occupancy and associated internal latent load. This design challenge is further complicated by applications such as a school, where occupancy is highly variable (students entering and leaving a classroom). The sensible and latent heat removal required from the space thus varies and requires a system that can adapt. These applications require that the system maintain comfort zone conditions when the space requires conditioning to lower the temperature alone (higher SHR), lower the temperature and humidity levels (intermediate SHR), or lower the humidity level alone (lower SHR).

5. Operating Efficiency and Energy Use:

When dehumidification alone (not cooling) in the space is required to reduce high humidity levels, occupants may attempt to lower the space thermostat set point. This action initiates the operation of the rooftop unit to cool the space. Since a rooftop without the Humidi-MiZer adaptive dehumidification option is not able to satisfy sole dehumidification requirements, the space is overcooled. The equipment cycles needlessly,

wasting energy because the equipment without the Humidi-MiZer[®] adaptive dehumidification option is unable to meet part load dehumidification conditions.

The Humidi-MiZer adaptive dehumidification system employs a method for operating at part load to satisfy sole dehumidification requirements by providing neutral air to the space. Neutral air is returned to the rooftop unit (at room conditions), cooled and dehumidified (down to roughly 55°F), and reheated to near room temperature set point conditions (72°F to 75°F). Since the neutral supply air has the same temperature as the space, sensible heat from the space is not absorbed. In addition, since only the supply air was reheated, the moisture removal capability has not changed. Therefore, air is supplied to the room, absorbs moisture, and returns to the rooftop where the moisture is removed. Once the air in the rooftop is cooled and dehumidified, it is reheated again and the cycle continues until dehumidification requirements are met. This provides an energy efficient method for reheating the supply air since the energy source (hot refrigerant) is internal, not external, to the rooftop unit.

Reheating air to neutral conditions will provide the maximum amount of dehumidification. However, partial reheating of air will also be beneficial to satisfying intermediate space conditions. For example, when the space experiences higher humidity levels, and the temperature is not satisfied by the dehumidification process alone, partial reheat may be required to remove a lesser degree of sensible heat, and a higher proportion of latent heat. The rooftop would then repeat the process and the supply air would be reheated between 60°F to 65°F as opposed to the neutral conditioned air. Since the supply-air temperature is now lower than the space, sensible heat will be removed, but in a lower proportion than if the air was supplied at 55°F (which would be typical of normal rooftop operation without the Humidi-MiZer adaptive dehumidification system). Rooftop systems that include reheat operation, but without this intermediate step, would have to cycle between normal rooftop and reheat operation. Although this would be more effective than normal rooftop operation alone, the provision for an intermediate operation point enables the system to more closely match space part load conditions and further enhance both space comfort conditions and operational equipment efficiency.

The strategy to maintain sole humidity complies with the latest energy efficiency standards such as in ASHRAE (American Society of Heating, Refrigeration and Air Conditioning Engineers) 90.1. Typically, Standard 90.1 prevents the use of reheating by external energy sources (electric resistance) or simultaneous mixing of hot and cold airstreams (multizone units).

TYPICAL APPLICATIONS

Many applications can benefit from utilizing the Humidi-MiZer adaptive dehumidification system. The following exhibit conditions in which the Humidi-MiZer adaptive dehumidification system would be an ideal enhancement to the 48/50TC or 48/50HC rooftop unit.

Applications that may exhibit some or all of the design challenges outlined previously include:

Schools —

Due to variable student occupancy with constant changes in ventilation air change requirements in each classroom, the proportion of latent load will be high, and humidity may rise. High humidity levels can damage computer equipment or building structural materials. In addition, students entering and leaving classrooms result in a variation in latent load for each room, which requires maximum part load dehumidification control.

Restaurants and Fast Food Chains —

Like schools, higher variable occupancy can result in humidity issues, along with kitchen areas of restaurants that have many humidity producing activities, such as dish washing and cooking.

Health Clubs —

Shower areas and human perspiration can cause uncomfortable and higher humidity space conditions. In addition to human discomfort, these conditions can propagate the growth of mold and mildew.

Convenience Stores and Supermarkets —

High humidity levels can cause inefficient operation of refrigeration and freezer systems.

Museums and Libraries —

These applications require a tighter degree of tolerance to maintain part load conditions, since high humidity levels can cause substantial damage to priceless books and artifacts.

Humid Climates —

In climates along the coast, when the temperature drops, the outdoor wet bulb may still remain the same or higher. This results in a need to provide more latent capacity to prevent humidity levels from increasing in the space.

NOTE: The system is designed to satisfy human comfort zone levels and is not designed for use in a space where precise humidity control is required, such as where pharmaceutical drying processes or chemical processes are conducted.

SYSTEM OVERVIEW

Modes of Operation —

The design of the Humidi-MiZer adaptive dehumidification system allows for dual humidity control mode of operation of the rooftop unit, utilizing a common subcooling/reheat dehumidification coil located downstream of the standard evaporator coil. This unique and innovative design provides the capability for the rooftop unit to operate in both a subcooling mode and a hot gas reheat mode for maximum system flexibility. The dehumidification package is factory wired to operate whenever there is a dehumidification requirement. To control the normal rooftop and dehumidification modes of

operation, either a Carrier Thermidstat device or thermostat and a wall-mounted humidity sensor may be added. The Carrier Thermidstat (see Fig. 5) or humidistat device (see Fig. 6) will only activate dehumidification operation when the occupied space humidity levels are undesirable. The Thermidstat or humidistat device humidity set point is typically set for 60% rh (relative humidity) or lower.



Fig. 5 - Carrier Thermidstat Device

C09296

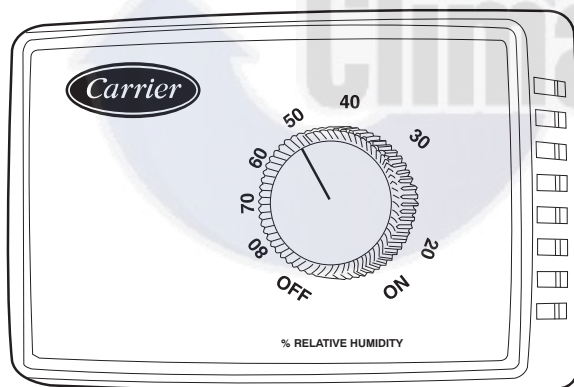

Fig. 6 - Carrier Humidistat Device

C09295

The unit will attempt to maintain the space humidity set point, and initiate subcooling mode when the space temperature and humidity are both above the temperature and humidity set points. The hot gas reheat mode will be initiated when just the humidity is above the humidity set point, without a demand for cooling.

Normal Design Cooling Operation —

When the rooftop operates under the normal sequence of operation, the compressors will cycle to maintain indoor conditions. See Fig. 7.

The Humidi-MiZer[®] adaptive dehumidification system includes a factory installed Motormaster[®] low ambient control to keep the head and suction pressure high, allowing normal design cooling mode operation down to 0°F.

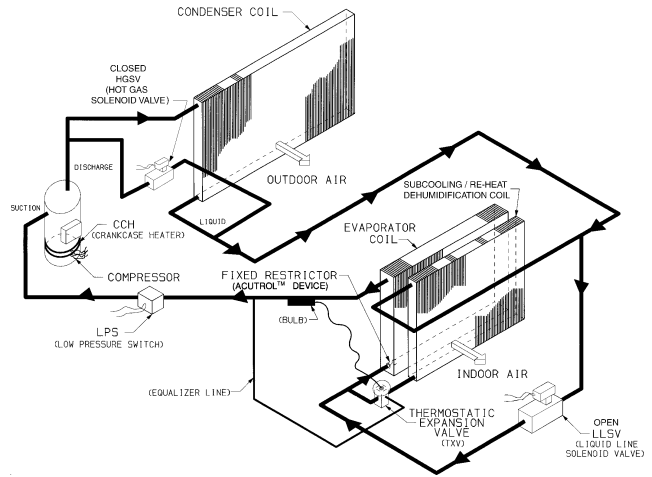

Fig. 7 - Normal Design Cooling Operation

C12719

Subcooling Mode —

When subcooling mode is initiated, this will energize (close) the liquid line solenoid valve (LLSV) forcing the hot liquid refrigerant to enter into the subcooling/reheat dehumidification coil (see Fig. 8).

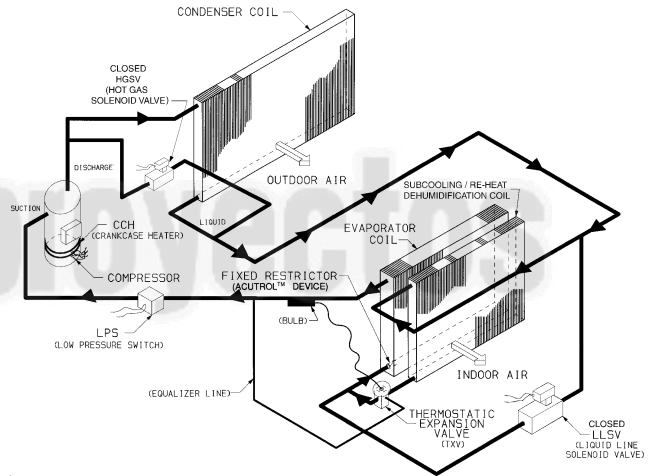

Fig. 8 - Subcooling Mode Operation

C12720

As the hot liquid refrigerant passes through the subcooling/reheat dehumidification coil, it is exposed to the cold supply airflow coming through the evaporator coil. The liquid is further subcooled to a temperature approaching the evaporator leaving-air temperature. The liquid then enters a thermostatic expansion valve (TXV) where the liquid drops to a lower pressure. The TXV does not have a pressure drop great enough to change the liquid to a 2-phase fluid, so the liquid then enters the Acutrol[™] device at the evaporator coil.

The liquid enters the evaporator coil at a temperature lower than in standard cooling operation. This lower temperature increases the latent capacity of the rooftop unit. The refrigerant passes through the evaporator and is turned into a vapor. The air passing over the evaporator coil will become colder than during normal operation. However, as this same air passes over the subcooling coil, it will be slightly warmed, partially reheating the air.

48-50TCHC-01XA

Subcooling mode operates only when the outside air temperature is warmer than 40°F. A factory-installed temperature switch located in the condenser section will lock out subcooling mode when the outside temperature is cooler than 40°F.

The scroll compressors are equipped with crankcase heaters to provide protection for the compressors due to the additional refrigerant charge required by the subcooling/reheat coil.

When in subcooling mode, there is a slight decrease in system total gross capacity (5% less), a lower gross sensible capacity (20% less), and a greatly increased latent capacity (up to 40% more).

Hot Gas Reheat Mode —

When the humidity levels in the space require humidity control, a hot gas solenoid valve (specific to hot gas reheat mode only) will open to bypass a portion of hot gas refrigerant around the condenser coil (see Fig. 9).

This hot gas will mix with liquid refrigerant leaving the condenser coil and flow to the subcooling/reheat dehumidification coil. Now the conditioned air coming off the evaporator will be cooled and dehumidified, but will be warmed to neutral conditions (72°F to 75°F) by the subcooling/reheat dehumidification coil.

NOTE: The 48/50TC/HC rooftop units can operate one circuit in subcooling mode and one circuit in hot gas reheat mode or both circuits in hot gas reheat mode, or both in normal design cooling mode.

The net effect of the rooftop when in hot gas reheat mode is to provide nearly all latent capacity removal from the space when sensible loads diminish (when outdoor

temperature conditions are moderate). When in hot gas reheat mode, the unit will operate to provide mostly latent capacity and extremely low sensible heat ratio capability.

Similar to the subcooling mode of operation, hot gas reheat mode operates only when the outside air temperature is warmer than 40°F. Below this temperature, a factory installed outside air temperature switch will lock out this mode of operation.

Rooftop System Performance —

Rooftop performance for standard units, subcooling mode and hot gas reheat mode can be found in the 48/50TC/HC Product Data.

Static pressure is also slightly affected by the addition of the subcooling/reheat dehumidification coil. See Fig. 10 for static pressure drop when using this option.

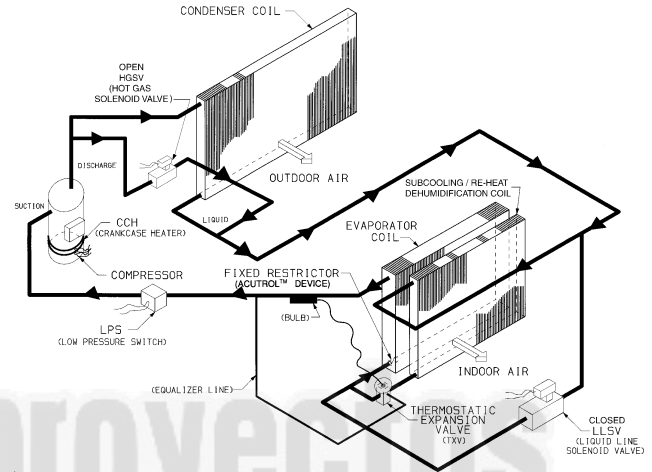

Fig. 9 - Hot Gas Reheat Mode Operation

C12721

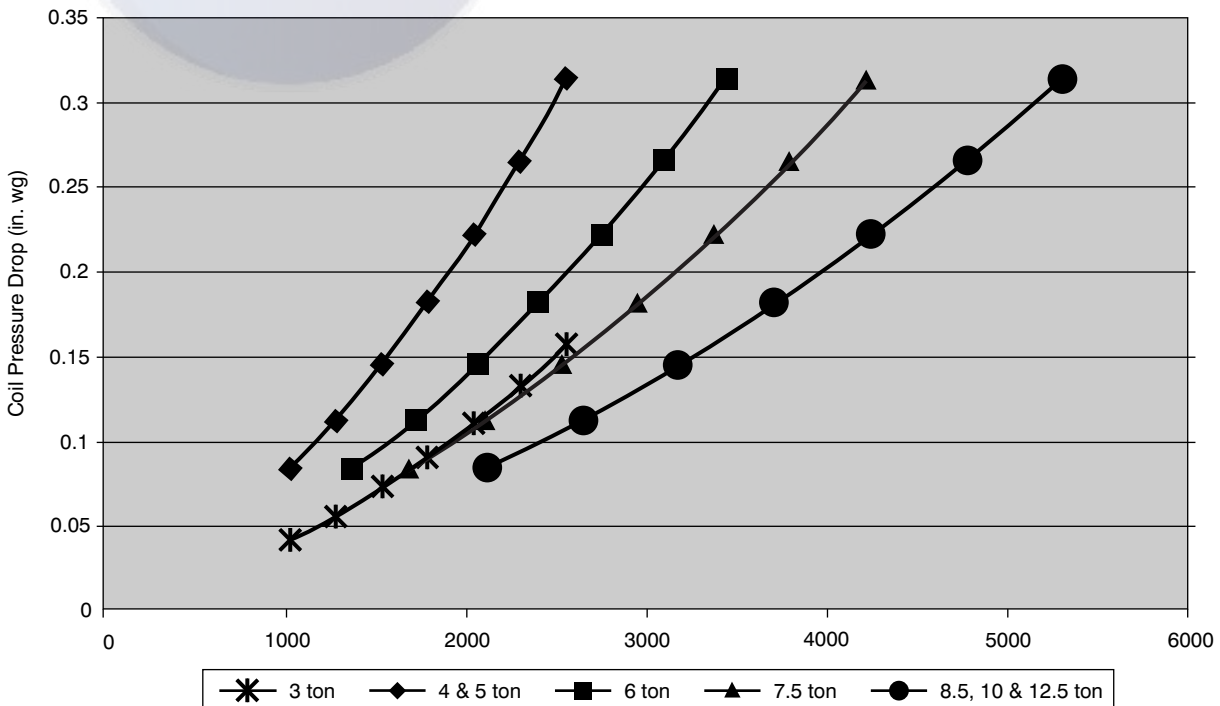

Fig. 10 - Humidi-MiZer® Adaptive Dehumidification Coil Pressure Drop

C12722

SYSTEM SELECTION

Design Example —

This section outlines a brief design example to illustrate the flexibility and dehumidification capacity of the Humidi-MiZer[®] adaptive dehumidification system. The example directly reinforces and demonstrates the design challenges as previously outlined when designing to maintain changing space conditions to sustain comfort zone levels. In addition, the rooftop system response is outlined to represent the sequence of operation of a 48/50TC/HC rooftop unit with the Humidi-MiZer adaptive dehumidification system and how this system would perform when the space humidity levels exceed the room set point.

Consider a school classroom in Houston, Texas with the following design characteristics:

- Total classroom area = 1,500 sq ft
- Total classroom volume = 15,000 cu ft

The design occupancy for this classroom is 30 students or roughly 10 people per 500 sq ft. Based on this occupancy, in accordance with ASHRAE (American Society of Heating, Refrigeration, and Air Conditioning Engineers) 62, the design ventilation rate would be 15 cfm/person or 450 cfm, total for this classroom.

To evaluate the full and part load rooftop performance, design requirements for the classroom will be evaluated at three conditions to assess annual full and part load operation to include:

1. Peak dry bulb (outdoor)
2. Peak dew point (outdoor)
3. Extremely high humidity (outdoor)

For each condition, the necessary rooftop performance will be calculated to evaluate the capacity requirements and associated required supply-air temperature from the unit to maintain space comfort conditions. The following formulas will be used:

$$\text{OA Sensible Load} = 1.08 \times \text{cfm}_{\text{oa}} \times (T_{\text{oa}} - T_{\text{sp}})$$

$$\text{OA Latent Load} = 0.7 \times \text{cfm}_{\text{oa}} \times (W_{\text{oa}} - W_{\text{sp}})$$

Where:

Cfm_{oa} = outdoor airflow in cu ft/min

T_{oa} = temperature of outdoor air in degrees of Fahrenheit

T_{sp} = temperature of space in degrees of Fahrenheit

W_{oa} = grains of water per pound of dry air of outdoor air

W_{sp} = grains of water per pound of dry air of space

NOTE: The W_{oa} and W_{sp} values of outdoor air can be obtained using the psychrometric chart.

Peak Dry Bulb —

For Houston, the outdoor peak dry bulb (db) and coincident mean wet bulb (mwb) 1% conditions are 94°F db and 77°F (per the ASHRAE Fundamentals Handbook). The design room conditions are 75°F (space temperature) db and 62.5°F wet bulb (wb) (or roughly 50% relative humidity).

At these conditions, the calculated indoor sensible (wall, roof, solar, windows, etc.) and latent (people) room loads for the classroom are **33,000 Btuh** and **6,150 Btuh**. The total room load is $33,000 + 6,150 = \mathbf{39,150 \text{ Btuh}}$.

For design purposes, there will be roughly 6.5 air changes per hour for the classroom. Therefore, the constant volume supply air from the rooftop unit would be $(15,000 \text{ cu ft} \times 6.5)/60 =$ approximately 1,600 cfm. For this design supply airflow rate, the mixed air conditions entering the standard evaporator coil is 80.3°F db/66.7°F wb. See Table 1 for summary of peak db temperature conditions. In addition the calculated outdoor air loads are:

$$\text{OA (sensible)} = 1.08 \times 450 \times (94 - 75) = \mathbf{9,276 \text{ Btuh}}$$

$$\text{OA (latent)} = 0.7 \times 450 \times (111 - 72) = \mathbf{11,934 \text{ Btuh}}$$

The total capacity required of the rooftop unit including all sensible and latent room and outdoor loads is:

$$\mathbf{33,000 + 6,150 + 9,276 + 11,934 = 60,360 \text{ Btuh}}$$

Including total sensible capacity:

$$\mathbf{33,000 + 9,276 = 42,776}$$

Total latent capacity:

$$\mathbf{6,150 + 11,934 = 18,084}$$

Select the 48/50TC/HC*06 5-ton rooftop unit based on the total outdoor air and room load requirements.

Table 1 – Peak Dry Bulb, Temperature Summary

TEMPERATURE SUMMARY	DRY BULB	WET BULB
Outside–Air Temperature	94°F	77°F
Space Temperature	75°F	62.5°F
Entering–Air Temperature	80.3°F	66.7°F

Now that the desired supply air quantity is known, it is possible to estimate the required supply air temperature and performance for the rooftop unit to maintain the desired indoor conditions. At peak conditions, the SHR (the sensible to total heat rise in the room) and associated supply air temperature requirement is:

$$\text{SHR (Peak Dry Bulb)} = 33,000/39,150 = \mathbf{0.84}$$

$$\mathbf{33,000 \text{ Btuh} = 1.08 \times 1,600 \text{ cfm} \times (75^\circ\text{F} - T)}$$

$$\text{Supply Air Temperature} = \mathbf{56^\circ\text{F}}$$

A supply-air temperature of 56°F is required for the sensible to total (SHR) heat ratio of 0.84 in the room. A supply-air temperature of 56°F is required to absorb the proportions of sensible and latent room load (per the SHR), so that space conditions are maintained at 75°F. Table 2 outlines a comparison of classroom requirements vs. actual rooftop performance to summarize the required classroom conditioning and the associated rooftop capacity under peak dry bulb conditions.

Table 2 provides a breakdown of all the room load information and rooftop performance. To determine the available capacity that the rooftop unit has for room sensible and latent conditioning, the outdoor loads were subtracted from the total loads. For example, to evaluate the sensible capacity available for room conditioning, the outdoor sensible load of **9,276 Btuh** was subtracted from the total

rooftop sensible capacity of **42,930 Btuh**. This yields a sensible capacity of **33,654 Btuh**, which closely matches the classroom sensible requirement of **33,000 Btuh**. The same calculation can be made to evaluate latent capacity requirements as shown in Table 2. Overall, under the peak dry bulb condition, the rooftop unit is sized appropriately to handle both the outdoor ventilation loads and room loads.

Table 2 – Peak Dry Bulb Operation Summary, Normal Design Cooling Mode

48/50TC/HC06	CLASSROOM REQUIREMENTS (Computer Simulation)	ROOFTOP PERFORMANCE (ECAT)
Total Capacity	60,360 Btuh	61,113 Btuh
Outdoor Sensible	9,276 Btuh	—
Outdoor Latent	11,934 Btuh	—
Sensible Capacity	—	42,930 Btuh
Latent Capacity	—	18,183 Btuh
Room Sensible	33,000 Btuh	33,654 Btuh
Room Latent	6,150 Btuh	6,249 Btuh
Supply Air	56°F	55.8°F
SHR	0.84	0.84

LEGEND

- DB** — Dry Bulb
- ECAT** — Carrier Electronic Catalog Program
- SHR** — Sensible Heat Ratio
- WB** — Wet Bulb

NOTES:

1. Data provided in terms of gross capacities.
2. Peak Dry Bulb Condition = 94°F DB/77°F WB.

Peak Dew Point —

Now that a unit has been selected for peak dry bulb conditions, evaluate the necessary and actual part load performance for the peak dew point condition in Houston. The peak dew point condition almost never coincides with the peak dry bulb condition. The coincident dry bulb at the peak wet bulb will usually be somewhat lower. This decreases room sensible loads, which are based on temperature difference dependent thermal conduction (through walls, roof, windows, etc.). Yet, despite potentially lower sensible room loads based on a lower dry bulb, the latent loads in the space will remain the same, since the classroom occupancy is designed for 30 people. Evaluating the performance at this point provides further verification that the selected unit will operate to meet comfort conditions in the space, based on different load conditions from peak dry bulb performance.

The ASHRAE Fundamental Handbook outlines peak dew point (dp) and coincident mean dry bulb (mdb) information. For Houston, the peak dew point 1% conditions are 77°F dp and 83°F mdb. Room design is still 75 F db and 50% relative humidity (rh). Mixed air conditions entering the rooftop standard evaporator coil are 77°F db and 66.7°F wb. At these outdoor conditions, the sensible load in the space drops to **25,000 Btuh** and the latent load remains the same at **6,150 Btuh**. The total room load is 25,000 + 6,150 = **31,150 Btuh**. See Table 3 for a peak dew point temperature summary.

The outdoor loads on the rooftop unit are now:

OA (sensible) = 1.08 x 450 x (83 – 75) = 3,888 Btuh
OA (latent) = 0.7 x 450 x (130 – 72) = 17,748 Btuh

Table 3 – Peak Dew Point, Temperature Summary

TEMPERATURE SUMMARY	DRY BULB	WET BULB
Outside–Air Temperature	83°F	77°F
Space Temperature	75°F	62.5°F
Entering–Air Temperature	77°F	66.7°F

The total capacity required of the rooftop unit including all sensible and latent room and outdoor loads is:
25,000 + 6,150 + 3,888 + 17,748 = 52,786 Btuh

Including total sensible capacity:
25,000 + 3,888 = 28,888 Btuh

Total latent capacity:
6,150 + 17,748 = 23,898 Btuh

Based on this information, evaluate the required rooftop performance. At the peak dew point conditions, the SHR and associated supply air temperature requirements are:
SHR (Peak Dew Point) = 25,000/31,150 = 0.80
25,000 Btuh = 1.08 x 1,600 cfm x (75°F – T)
Supply-Air Temperature = 60°F

Due to the change in outdoor conditions, the indoor proportion of sensible and latent heat removal has changed along with the associated supply air temperature. In order to satisfy lower sensible load and same latent load of the room, a supply-air temperature of 60°F is required.

At this part load condition, consider the performance of the 48/50TC/HC06 rooftop unit with the Humidi-MiZer® adaptive dehumidification system to assess overall unit performance as was done for the dehumidification system. Table 4 provides a comparison for the peak dew point classroom requirements and the associated rooftop performance without the Humidi-MiZer adaptive dehumidification system.

Table 4 – Peak Dew Point Operation Summary, Rooftop Unit without the Humidi-MiZer Adaptive Dehumidification System

48/50TC/HC06	CLASSROOM REQUIREMENTS (Computer Simulation)	ROOFTOP PERFORMANCE (ECAT)
Total Capacity	52,786 Btuh	61,290 Btuh
Outdoor Sensible	3,888 Btuh	—
Outdoor Latent	17,748 Btuh	—
Sensible Capacity	—	38,040 Btuh
Latent Capacity	—	23,250 Btuh
Room Sensible	25,000 Btuh	34,152 Btuh
Room Latent	6,150 Btuh	5,502 Btuh
Supply Air	60°F	55.3°F
SHR	0.80	0.86

LEGEND

- DB** — Dry Bulb
- ECAT** — Carrier Electronic Catalog Program
- SHR** — Sensible Heat Ratio
- WB** — Wet Bulb

NOTES:

1. Data provided in terms of gross capacities.
2. Peak Dry Bulb Condition = 94°F DB/77°F WB.
3. Data in **bold** indicates unit is overcooling the space

At the provided dew point conditions, discharge from the rooftop is 55°F, which is nearly the same as it was for peak dry bulb conditions (it is slightly lower since entering conditions to the evaporator are lower). However, based on this supply-air temperature, the rooftop unit may over-cool the space and/or cycle on and off to try to accommodate the lower sensible load requirement. The bold rooftop performance is demonstrated in Table 4 where the available capacity for sensible room loads is roughly 36% more than is required under this part load condition. The standard rooftop unit may then over-cool the temperature in the classroom by providing 55°F supply air due to a higher concentration of latent to sensible load.

In response to these conditions, a rooftop unit equipped with the Humidi-MiZer® adaptive dehumidification system is the ideal solution to maintain the appropriate supply air temperature to satisfy the higher latent to sensible load ratio in the space at this part load condition. Under this condition, the rooftop would operate in subcooling mode to maintain space conditions. The performance from the rooftop in subcooling mode is outlined in Table 5 for peak dew point part load classroom requirements.

As shown in Table 5, the sensible capacity for the rooftop is slightly lower, and the supply-air temperature is 60 F. In subcooling mode the rooftop will be able to accommodate the change in sensible load and provide the appropriate supply-air temperature to maintain space conditions. Closely matching the sensible load to maintain indoor temperature conditions will allow the unit to properly maintain indoor humidity levels without occupants attempting to lower the thermostat set point, over-cooling the space, and wasting energy. The rooftop with the Humidi-MiZer system will respond to both the room thermostat and humidity-sensing device to attempt to maintain the space set points (75°F, 50% rh). In relation to the peak dew point condition, this means that both the room temperature and humidity may be above the set points, resulting in the unit to operate in subcooling mode. Therefore, with the subcooling mode initiated by the space temperature and humidity sensing device(s), the typical fixed envelope of operation for the rooftop adapts to maintain the space comfort.

Overall, the rooftop under peak dew point part load condition is able to adapt to the higher latent to sensible load ratio, which is not possible for a normal rooftop without the Humidi-MiZer adaptive dehumidification system. Rooftop units without the Humidi-MiZer system are not able to adapt, which leads to needless energy waste.

Table 5 – Peak Dew Point Operation Summary, Rooftop Unit with the Humidi-MiZer Adaptive Dehumidification System in Subcooling Mode

48/50TC/HC06	CLASSROOM REQUIREMENTS (Computer Simulation)	ROOFTOP PERFORMANCE (ECAT)
Total Capacity	52,786 Btuh	56,750 Btuh
Outdoor Sensible	3,888 Btuh	—
Outdoor Latent	17,748 Btuh	—
Sensible Capacity	—	28,860 Btuh
Latent Capacity	—	27,890 Btuh
Room Sensible	25,000 Btuh	24,972 Btuh
Room Latent	6,150 Btuh	10,142 Btuh
Supply Air	60°F	60.6°F
SHR	0.80	0.71

LEGEND

- DB** — Dry Bulb
- ECAT** — Carrier Electronic Catalog Program
- SHR** — Sensible Heat Ratio
- WB** — Wet Bulb

NOTES:

1. Data provided in terms of gross capacities.
2. Peak Dry Bulb Condition = 94°F DB/77°F WB.

Extremely High Humidity —

Even though peak dew point information is provided by ASHRAE, this may not be the worst-case condition for analyzing indoor humidity control. Such a condition may exist on a rainy day when the outdoor air temperature is somewhat moderate. Consider a rainy day in Houston with outdoor conditions of 72°F db and 70°F wb. These conditions typically require latent heat removal alone. For our example, the sensible load is reduced to **5,000 Btuh** and the room latent load again remains the same at **6,150 Btuh**. The mixed air condition entering the rooftop evaporator coil is now 74°F db and 64.4°F wb. See Table 6 for extremely high humidity temperature summaries. At these conditions the outdoor air loads are:

$$\text{OA (sensible)} = 1.08 \times 450 \times (72 - 75) = -1458$$

(negative value indicates outdoor air is being heated)

$$\text{OA (latent)} = 0.7 \times 450 \times (108 - 72) = 11,016 \text{ Btuh}$$

The total room load is **5,000 + 6150 = 11,150 Btuh**

The total capacity required of the rooftop unit including all sensible and latent room and outdoor loads is:

$$5,000 + 6,150 + (-1,458) + 11,016 = 20,708 \text{ Btuh}$$

At this condition, the SHR and associated supply-air temperature requirement are:

$$\text{SHR (High Humidity)} = 5,000/11,150 = 0.45$$

$$5,000 \text{ Btuh} = 1.08 \times 1,600 \text{ cfm} \times (75^\circ\text{F} - T)$$

$$\text{Supply-Air Temperature} = 72.1 \text{ F}$$

Table 6 – Extremely High Humidity, Temperature Summary

TEMPERATURE SUMMARY	DRY BULB	WET BULB
Outside–Air Temperature	72°F	70°F
Space Temperature	75°F	62.5°F
Entering–Air Temperature	74°F	64.4°F

48–50TCHC–01XA

The supply-air temperature from the unit under normal operation and subcooling mode will be too low to accommodate this requirement. In this circumstance, the temperature in the space is potentially satisfied, however, sole humidity control may be required. As the humidity increases above the space humidity set point, this will initiate the hot gas reheat mode of operation for the rooftop unit equipped with the Humidi-MiZer[®] adaptive dehumidification system. See Table 7 for hot gas reheat mode performance. For this type of part load condition, evaluate the latent load requirements and associated equipment performance to determine whether the unit can maintain the appropriate supply-air temperature and latent capacity to control humidity without affecting the indoor temperature.

Table 7 – Extremely High Humidity Operation Summary, Humid Day Performance, Rooftop Unit with the Humidi-MiZer Adaptive Dehumidification System in Hot Gas Reheat Mode

48/50TC/HC06	CLASSROOM REQUIREMENTS (Computer Simulation)	ROOFTOP PERFORMANCE (ECAT)
Outdoor Latent	—	11,016 Btuh
Latent Capacity	—	19,610 Btuh
Room Latent	6,150 Btuh	8,594 Btuh
Supply Air	72.1°F	75.3°F
SHR	0.57	0.1

LEGEND

- DB** — Dry Bulb
- ECAT** — Carrier Electronic Catalog Program
- SHR** — Sensible Heat Ratio
- WB** — Wet Bulb

NOTES:

1. Data provided in terms of gross capacities.
2. Outdoor Extremely High Humidity = 72°F DB/70°F WB.

As shown in Table 7, the supply-air temperature is 75°F, providing neutral air to the space for latent heat removal. The unit will operate and has sufficient capability to provide humidity control in the space as required. Once the humidity in the space is satisfied, the unit will operate in subcooling or normal mode to maintain space conditions. In other words, to satisfy this part load condition, the rooftop unit without the Humidi-MiZer adaptive dehumidification system may not be able to properly dehumidify the space. However, with the hot gas reheat mode initiated, the rooftop unit with the Humidi-MiZer adaptive dehumidification system feature has substantial latent capacity potential for handling the need for sole humidity control in the space.

Overall, this design example fully illustrates the benefits of utilizing the Humidi-MiZer adaptive dehumidification system under all peak and part load conditions for maintaining comfort levels in the space. The rooftop unit performance is expanded depending on the mode of operation required for space conditioning, to provide maximum part load flexibility and dehumidification capacity when required. The benefit is better part load operation to provide more efficient energy utilization, and a better degree of space temperature and humidity control to keep occupants comfortable in the space year round. On 48/50TC/HC units

with two compressors (sizes 08-30) even further part load capabilities exist. Depending on the conditions required to maintain the space set points, one or both compressors could operate in subcooling mode, one compressor could operate in subcooling mode, while the other operates in hot gas reheat mode, or one or both compressors can operate in hot gas reheat mode.

Economizer Usage —

Special consideration should be given when selecting an economizer changeover strategy for use with the Humidi-MiZer adaptive dehumidification system. Any economizer control strategy can be employed including:

- dry bulb
- differential dry bulb
- enthalpy
- differential enthalpy

However, based on the application involved and the humidity requirements for the space, it may be more desirable to utilize either enthalpy or differential enthalpy economizer changeover. Using either one of these two strategies minimizes the potential for an increase in space humidity, since enthalpy changeover reduces the possibility of bringing in more humid air for free cooling. Minimizing the introduction of more humid air for free cooling will further streamline rooftop operation, since humidity levels will not increase in the space. Since the goal of implementing the Humidi-MiZer adaptive dehumidification system is to maintain space conditions due to increasing proportions of humidity, utilizing a changeover strategy such as dry bulb may work against this design goal. Dry bulb economizer changeover utilizes outdoor air for free cooling without considering the moisture content of the outdoor air. If dry bulb changeover is utilized, a low enough changeover point should be selected to avoid bringing in moisture-laden outdoor air. Ultimately, the economizer strategy utilized is outlined in ASHRAE Standard 90.1, where the changeover strategy employed may be limited based on the climate where the rooftop is installed.

SEQUENCE OF OPERATION

The response of the Humidi-MiZer adaptive dehumidification system to varying space conditions is extremely dynamic. 48/50/TC/HC rooftop units equipped with the Humidi-MiZer system will respond based on the temperature and humidity requirements as sensed in the space. Either a Carrier thermidstat device (combined temperature and humidity sensing capability) or a separate thermostat and humidistat can be used with the Humidi-MiZer system.

The Humidi-MiZer option includes additional valves in the liquid line and discharge line of each refrigerant circuit, a small reheat condenser coil downstream of the evaporator, and Motormaster variable--speed control of some or all outdoor fans. Operation of the revised refrigerant circuit for each mode is described below.

The Humidi-MiZer system provides three sub-modes of operation: Cooling mode, Subcooling mode, and Hot Gas

Reheat mode. Cooling mode provides a normal ratio of Sensible and Latent Cooling effect from the evaporator coil. Subcooling mode provides increased Latent Cooling while slightly reducing the Sensible Cooling effect. Hot Gas Reheat mode provides normal Latent Cooling but with null or minimum Sensible Cooling effect delivered to the space.

The Subcooling and Hot Gas Reheat modes are available when the unit is not in a Heating mode and when the Low Ambient Lockout switch is closed.

48/50TC Units (Standard Efficiency Units)

48/50TC Size 04-07 Units (Single Circuit) —

When there is only a cooling demand (thermostat Y1 calling), the single circuit will operate in normal cooling mode. The solenoid valves CSV and DSV are de-energized. The liquid solenoid valve CSV is a Normally Open valve; it remains open in the Cooling mode. The discharge gas valve DSV is Normally Closed; it remains closed during the Cooling mode.

When the unit is operating in a Cooling Mode (space temperature above setpoint, Y1 calling) and the space humidity is also above its setpoint, the humidistat will close and the unit operation will shift to Subcooling mode. The liquid solenoid valve CSV will become energized, causing the valve to close and redirecting all liquid flow into the Subcooler/Reheat coil. The increased subcooling causes the evaporator coil surface temperature to decrease, thus increasing the unit's Latent Cooling effect. Solenoid valve DSV remains de-energized and closed.

When there is only dehumidification demand (humidistat is above setpoint but no Y1 call), the unit will operate in Hot Gas Reheat mode. The supply fan motor and the compressor will be energized through the Reheat Control Board logic. Both solenoids are energized; valve CSV closes and discharge bypass valve DSV opens. All liquid flow and the bypassed discharge gas are directed into the Subcooler/Reheat coil. The additional heat from the bypass discharge gas offsets the Sensible Cooling effect from the evaporator coil during Hot Gas Reheat mode. See Hot Gas Reheat Schematic for system refrigerant flow.

48/50TC Size 08-14 Units (Two Circuits) —

When there is only a cooling demand (thermostat Y1 alone or with Y2), one or both circuits will operate in normal cooling mode. Both solenoid valves in both circuits are de-energized. The liquid solenoid valves CSV1,2 are Normally Open valves; they remain open in the Cooling mode. The discharge gas valves DSV1,2 are Normally Closed; they remain closed during the Cooling mode.

When the unit is operating in a full-load Cooling Mode (space temperature above setpoint, both Y1 and Y2 calling) and the space humidity is also above its setpoint, the humidistat will close and the unit operation will shift to Subcooling mode. The liquid solenoid valves CSV1 and CSV2 will become energized, causing the valves to close and redirecting all liquid flow into the Subcooler/Reheat coil circuits. The increased subcooling causes the evaporator coil surface temperature to decrease, thus

increasing the unit's Latent Cooling effect. Solenoid valves DSV1,2 remain de-energized and closed.

When the unit is operating in a part-load Cooling Mode (space temperature above setpoint, only Y1 calling) and the space humidity is also above its setpoint, the humidistat will close and the unit operation will shift to Subcooling mode in Circuit 1 and Hot Gas Reheat mode (Dehumidification) in Circuit 2. The liquid solenoid valves CSV1 and CSV2 and discharge gas valve DSV2 will be energized; valve DSV1 remains de-energized and closed. Circuit 1 will operate in Subcooling mode as described above. Circuit 2 will operate in Hot Gas Reheat mode as described below.

When there is only dehumidification demand (humidistat is above setpoint but no Y1 call), both circuits will operate in Hot Gas Reheat mode. The supply fan motor and both compressors will be energized through the Reheat Control Board logic. All solenoids are energized; valves CSV1,2 close and discharge bypass valves DSV1,2 open. All liquid flow and the bypassed discharge gas are directed into the Subcooler/Reheat coil circuits. The additional heat from the bypass discharge gas offsets the Sensible Cooling effect from the evaporator coil during Hot Gas Reheat mode. See Hot Gas Reheat Schematic for system refrigerant flow.

All 48/50TC Units —

If the space temperature drops during a Hot Gas Reheat mode until the heating thermostat W1 closes, the W1 signal is received at the Reheat Control Board. The Reheat Control Board logic will de-energize all compressors and solenoid valves. The compressors and solenoid valves will remain de-energized until the Heating mode demand ends. If the humidistat is still above setpoint after Heating ends, the unit will restart in Hot Gas Reheat mode.

48/50TC Size 16 Units (Two Circuits) —

When there is only a cooling demand (thermostat Y1 alone or with Y2), one or both circuits will operate in normal cooling mode. Both solenoid valves in both circuits are de-energized. The liquid solenoid valves LDV1,2 are 3-Way valves with a Normally Open (NO) port and a Normally Closed (NC) port; in the Cooling mode, the liquid flows out the Normally Open port and into the TXVs on the evaporator coil. The discharge gas valves RDV1,2 are Normally Closed; they remain closed during the Cooling mode.

When the unit is operating in a full-load Cooling Mode (space temperature above setpoint, both Y1 and Y2 calling) and the space humidity is also above its setpoint, the humidistat will close and the unit operation will shift to Subcooling mode. The liquid solenoid valves LDV1 and LDV2 will become energized, causing the valves to close their NO ports, open their NC ports and redirecting all liquid flow into the Subcooler/Reheat coil circuits. The increased subcooling causes the evaporator coil surface temperature to decrease, thus increasing the unit's Latent Cooling effect. Solenoid valves RDV1,2 remain de-energized and closed.

When the unit is operating in a part-load Cooling Mode (space temperature above setpoint, only Y1 calling) and the space humidity is also above its setpoint, the humidistat will close and the unit operation will shift to Subcooling mode in Circuit 1 and Hot Gas Reheat mode (Dehumidification) in Circuit 2. The liquid solenoid valves LDV1 and LDV2 and discharge gas valve RDV2 will be energized; valve RDV1 remains de-energized and closed. Circuit 1 will operate in Subcooling mode as described above. Circuit 2 will operate in Hot Gas Reheat mode as described below.

When there is only dehumidification demand (humidistat is above setpoint but no Y1 call), both circuits will operate in Hot Gas Reheat mode. The supply fan motor and both compressors will be energized through the Reheat Control Board logic. All solenoids are energized; valves LDV1,2 close their NO ports and open their NC ports and discharge bypass valves RDV1,2 open. All liquid flow and the bypassed discharge gas are directed into the Subcooler/Reheat coil circuits. The additional heat from the bypass discharge gas offsets the Sensible Cooling effect from the evaporator coil during Hot Gas Reheat mode. See Hot Gas Reheat Schematic for system refrigerant flow.

48/50HC Units (High Efficiency Units)

48/50HC Size 04-07 Units (Single Circuit) —

When there is only a cooling demand (thermostat Y1 calling), the single circuit will operate in normal cooling mode. The Cooling Liquid Valve CLV is energized and open, permitting liquid flow around the Reheat coil and directly to the unit's TXV and evaporator coil. The solenoid valves RLV and RDV are de-energized and remain closed during the Cooling mode.

When the unit is operating in a Cooling Mode (space temperature above setpoint, Y1 calling) and the space humidity is also above its setpoint, the humidistat will close and the unit operation will shift to Subcooling mode. The Cooling Liquid Valve CLV is de-energized and closed, blocking liquid flow around the Reheat coil. The Reheat Liquid Valve RLV is energized and open, directing all liquid flow into the Subcooler/Reheat coil. The increased subcooling causes the evaporator coil surface temperature to decrease, thus increasing the unit's Latent Cooling effect. Solenoid valve RDV remains de-energized and closed.

When there is only dehumidification demand (humidistat is above setpoint but no Y1 call), the unit will operate in Hot Gas Reheat mode. The supply fan motor and the compressor will be energized through the Reheat Control Board logic. The Cooling Liquid Valve CLV is de-energized and closed, blocking liquid flow around the Reheat coil. The Reheat Liquid Valve RLV is energized and open, directing liquid flow into the Subcooler/Reheat coil. The Reheat Discharge Valve is also energized and open, allowing bypassed discharge gas to mix with liquid entering the Subcooler/Reheat coil. The additional heat from the bypassed discharge gas offsets the Sensible Cooling effect from the evaporator coil during Hot Gas Reheat mode. See Hot Gas Reheat Schematic for system refrigerant flow.

48/50HC Size 08-12 Units (Two Circuit) —

When there is only a cooling demand (thermostat Y1 alone or with Y2), one or both circuits will operate in normal cooling mode. The Cooling Liquid Valves CLV1 and CLV2 are energized and open, permitting liquid flow around the Reheat coil and directly to the unit's TXVs and evaporator coil. The solenoid valves RLV1, RLV2, RDV1 and RDV2 are de-energized and remain closed during the Cooling mode.

When the unit is operating in a full-load Cooling Mode (space temperature above setpoint, both Y1 and Y2 calling) and the space humidity is also above its setpoint, the humidistat will close and the unit operation will shift to Subcooling mode. The Cooling Liquid Valves CLV1 and CLV2 are de-energized and closed, blocking liquid flow around the Reheat coil. The Reheat Liquid Valves RLV1 and RLV2 are energized and open directing all liquid flow into the Subcooler/Reheat coil circuits. The increased subcooling causes the evaporator coil surface temperature to decrease, thus increasing the unit's Latent Cooling effect. Solenoid valves RDV1 and RDV2 remain de-energized and closed.

When the unit is operating in a part-load Cooling Mode (space temperature above setpoint, only Y1 calling) and the space humidity is also above its setpoint, the humidistat will close and the unit operation will shift to Subcooling mode in Circuit 1 and Hot Gas Reheat mode (Dehumidification) in Circuit 2. Compressor 2 will be energized through the Reheat Control Board logic. The Cooling Liquid Valves CLV1 and CLV2 are de-energized and closed, blocking liquid flow around the Reheat coil. The Reheat Liquid Valves RLV1 and RLV2 are energized and open, directing liquid flow into the Subcooler/Reheat coil. The Reheat Discharge Valve RDV2 is also energized and open, allowing bypassed discharge gas to mix with liquid entering the Subcooler/Reheat coil's Circuit 2. Solenoid valve RDV1 remains de-energized and closed. Circuit 1 will operate in Subcooling mode as described above. Circuit 2 will operate in Hot Gas Reheat mode as described below.

When there is only dehumidification demand (humidistat is above setpoint but no Y1 call), both circuits will operate in Hot Gas Reheat mode. The supply fan motor and both compressors will be energized through the Reheat Control Board logic. The Cooling Liquid Valves CLV1 and CLV2 are de-energized and closed, blocking liquid flow around the Reheat coil. The Reheat Liquid Valves RLV1 and RLV2 are energized and open, directing liquid flow into the Subcooler/Reheat coil. The Reheat Discharge Valves RDV1 and RDV2 are also energized and open, allowing bypassed discharge gas to mix with liquid entering the Subcooler/Reheat coil's two circuits. The additional heat from the bypassed discharge gas offsets the Sensible Cooling effect from the evaporator coil during Reheat2 mode. See Hot Gas Reheat Schematic for system refrigerant flow.

If the space temperature drops during a Hot Gas Reheat mode until the heating thermostat W1 closes, the W1 signal is received at the Reheat Control Board. The Reheat Control Board logic will de-energize all

compressors, energize the Cooling Liquid Valve(s) and de-energize the Reheat Cooling and Reheat Discharge Valves. The compressors and solenoid valves will remain in these conditions until the Heating mode demand ends. If the humidistat is still above setpoint after Heating ends, the unit will restart in Hot Gas Reheat mode.

48/50HC Size 14 Units (Two Circuits) —

When there is only a cooling demand (thermostat Y1 alone or with Y2), one or both circuits will operate in normal cooling mode. Both solenoid valves in both circuits are de-energized. The liquid solenoid valves LDV1,2 are 3-Way valves with a Normally Open (NO) port and a Normally Closed (NC) port; in the Cooling mode, the liquid flows out the Normally Open port and into the TXVs on the evaporator coil. The discharge gas valves RDV1,2 are Normally Closed; they remain closed during the Cooling mode.

When the unit is operating in a full-load Cooling Mode (space temperature above setpoint, both Y1 and Y2 calling) and the space humidity is also above its setpoint, the humidistat will close and the unit operation will shift to Subcooling mode. The liquid solenoid valves LDV1 and LDV2 will become energized, causing the valves to close their NO ports, open their NC ports and redirecting all liquid flow into the Subcooler/Reheat coil circuits. The increased subcooling causes the evaporator coil surface temperature to decrease, thus increasing the unit's Latent Cooling effect. Solenoid valves RDV1,2 remain de-energized and closed.

When the unit is operating in a part-load Cooling Mode (space temperature above setpoint, only Y1 calling) and

the space humidity is also above its setpoint, the humidistat will close and the unit operation will shift to Subcooling mode in Circuit 1 and Hot Gas Reheat mode (Dehumidification) in Circuit 2. The liquid solenoid valves LDV1 and LDV2 and discharge gas valve RDV2 will be energized; valve RDV1 remains de-energized and closed. Circuit 1 will operate in Subcooling mode as described above. Circuit 2 will operate in Hot Gas Reheat mode as described below.

When there is only dehumidification demand (humidistat is above setpoint but no Y1 call), both circuits will operate in Hot Gas Reheat mode. The supply fan motor and both compressors will be energized through the Reheat Control Board logic. All solenoids are energized; valves LDV1,2 close their NO ports and open their NC ports and discharge bypass valves RDV1,2 open. All liquid flow and the bypassed discharge gas are directed into the Subcooler/Reheat coil circuits. The additional heat from the bypassed discharge gas offsets the Sensible Cooling effect from the evaporator coil during Hot Gas Reheat mode. See Hot Gas Reheat Schematic for system refrigerant flow

If the space temperature drops during a Hot Gas Reheat mode until the heating thermostat W1 closes, the W1 signal is received at the Reheat Control Board. The Reheat Control Board logic will de-energize all compressors and solenoid valves. The compressors and solenoid valves will remain de-energized until the Heating mode demand ends. If the humidistat is still above setpoint after Heating ends, the unit will restart in Hot Gas Reheat mode.

Table 8 – Humidi-MiZer® Adaptive Dehumidification System Sequence of Operation and System Response — Single Compressor Units (48/50TC/HC 04-07)

THERMOSTAT INPUT			ECONOMIZER FUNCTION		48/50TC/HC UNIT OPERATION			
H	Y1	Y2	OAT. < Economizer Set Point	Economizer	Comp. 1	Subcooling Mode	Hot Gas Reheat Mode	
Off			Normal Operation					
On	On	On	No	Off	On	Yes	No	
On	On	Off	No	Off	On	Yes	No	
On	On	On	Yes	On	On	Yes	No	
On	On	Off	Yes	On	On	No	Yes	
On	Off	Off	No	Off	On	No	Yes	

LEGEND

OAT — Outdoor Air Temperature

Table 9 – Humidi-MiZer Adaptive Dehumidification System Sequence of Operation and System Response — Dual Compressor Units (48/50TC08-16 / 48/50HC**08-14)**

THERMOSTAT INPUT			ECONOMIZER FUNCTION		48/50TC/HC UNIT OPERATION					
					First Stage			Second Stage		
H	Y1	Y2	OAT. < Economizer Set Point	Economizer	Comp. 1	Subcooling Mode	Hot Gas Reheat Mode	Comp. 2	Subcooling Mode	Hot Gas Reheat Mode
Off			Unit Operates Under Normal Sequence of Operation							
On	On	On	No	Off	On	Yes	No	On	Yes	No
On	On	Off	No	Off	On	Yes	No	On	No	Yes
On	On	On	Yes	On	On	Yes	No	On	No	Yes
On	On	Off	Yes	On	On	No	Yes	On	No	Yes
On	Off	Off	No	Off	On	No	Yes	On	No	Yes

LEGEND

OAT — Outdoor Air Temperature

SYSTEM SPECIFICATIONS

1. The Humidi-MiZer dehumidification system shall be factory-installed in the 48/50TC/HC rooftop units, and shall provide greater dehumidification of the occupied space by two modes of dehumidification operations beside its normal design cooling mode:
 - a. Subcooling mode further subcools the hot liquid refrigerant leaving the condenser coil when both temperature and humidity in the space are not satisfied.
 - b. Hot gas reheat mode shall mix a portion of the hot gas from the discharge of the compressor with the hot liquid refrigerant leaving the condenser coil to create a two-phase heat transfer in the system, resulting in a neutral leaving-air temperature when only humidity in the space is not satisfied.
2. The system shall consist of a subcooling/reheat dehumidification coil located downstream of the standard evaporator coil. This dehumidification coil is a two-row coil with the exception of the 04 unit, which has a one-row coil.
3. The system shall include belly band heater(s) for the scroll compressor(s).
4. The system shall include a low outdoor air temperature switch to lock out both subcooling and hot gas reheat mode when the outdoor-air temperature is below 40 F.
5. The system shall include a Motormaster low ambient control to ensure the normal design cooling mode capable of down to 0° F low ambient operation.
6. The system shall include a low-pressure switch on the suction line to ensure low pressure start-up of hot gas reheat mode at lower outdoor temperature condition.
7. The system operation may be controlled by a field-installed, wall-mounted humidistat. The dehumidification circuit will then operate only when needed. Field connections for the humidistat are made in the low-voltage compartment of the unit control box. The sensor can be set for any level between 55% and 80% relative humidity.
8. The system shall include a Thermal Expansion Valve (TXV) to ensure a positive superheat condition and a balance of pressure drop.
9. For units with two compressors (sizes: 48/50TC 08-16 with Round Tube-Plate Fin coils only, 48/50HC 08-14), depending on the conditions required to maintain the space set points, one or both compressors can operate in subcooling mode, one compressor could operate in subcooling mode while the other operates in hot gas reheat mode, or one or both compressors can operate in hot gas reheat mode.

48-50TCHC-01XA

CONTROL WIRING APPLICATIONS

No matter which controls or accessories are provided with 48/50TC/HC units with the Humidi-MiZer® system, field control wiring is simple. This section outlines the necessary field control wiring diagrams for using the Humidi-MiZer system with standard units and PremierLink™ controls.

Standard Units —

For units that have the standard controls and the Humidi-MiZer system, either a Carrier Thermidistat device or separate thermostat and humidistat can be utilized. In either case, when the Humidi-MiZer system is included, control wires are provided in the rooftop control box at the factory for connection of both devices. See Fig. 11 and 12.

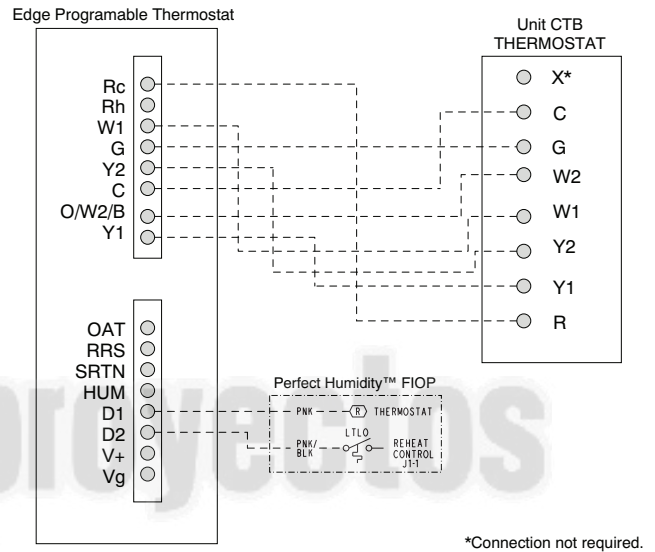

Fig. 11 - Carrier Thermidistat Field Control Wiring, Standard Controls

PremierLink Units —

For 48/50TC/HC units that are equipped with Carrier PremierLink DDC controls, a field-installed space temperature sensor is required for connection to PremierLink control. In addition, a space humidistat is required for connection to the rooftop unit as illustrated in Fig. 13.

RTU Open Units —

48/50TC/HC units that are equipped with the RTU Open controller require a space relative humidity sensor or a humidistat for control. See Fig. 14.

ComfortLink Units —

48/50HC units that are equipped with the factory-installed ComfortLink control option require installation and configuration of either a space relative humidity sensor or relative humidity switch for control. See Fig. 15.

NOTE: ComfortLink is not available for 48/50TC units.

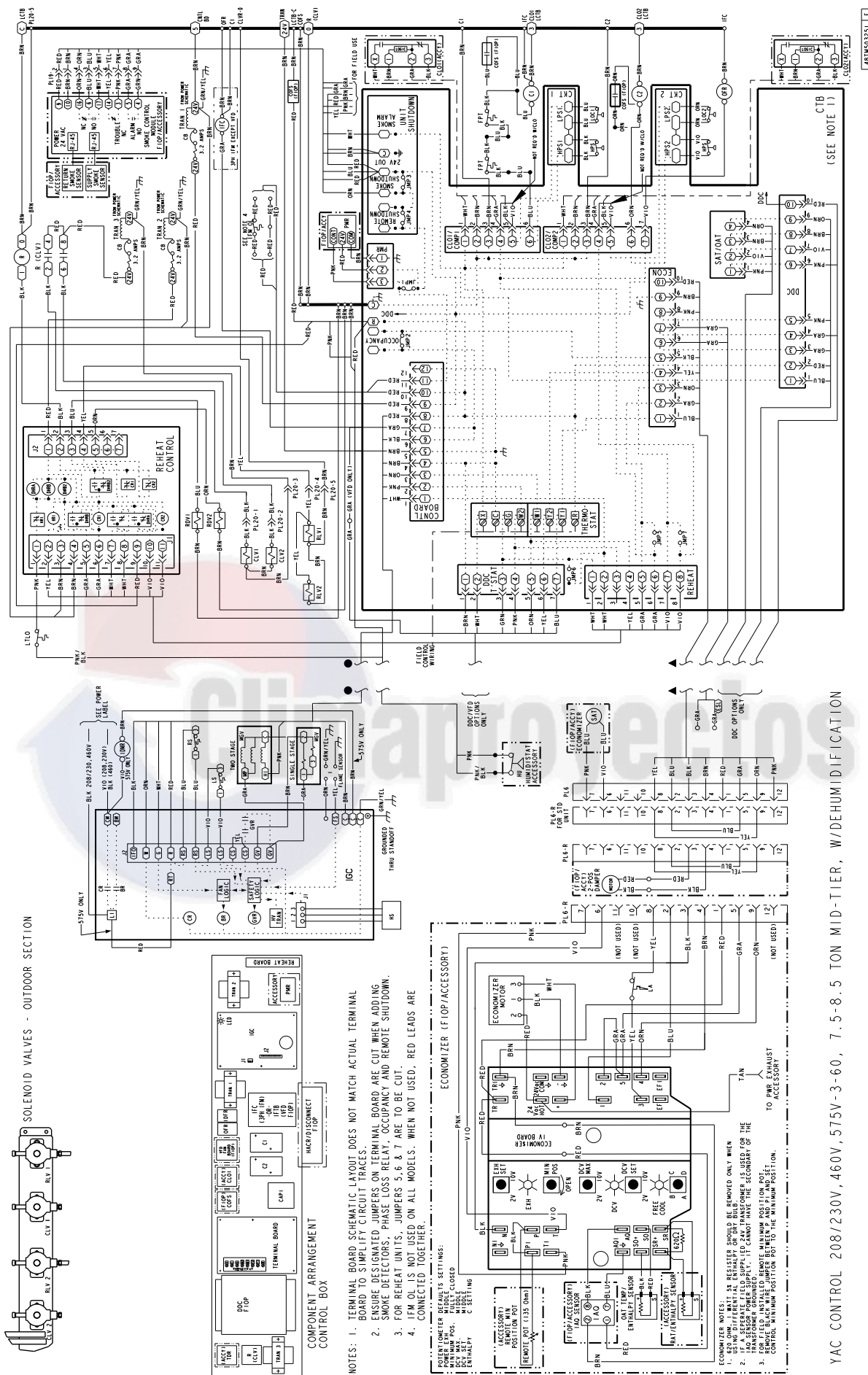

Fig. 12 - Typical Field Control Wiring 48/50TC/HC — Standard Units with Humidi-MiZer®

C12723

YAC CONTROL 208/230V, 460V, 575V-3-60
7.5-8.5 TON MID-TIER, W/DEHUMIDIFICATION

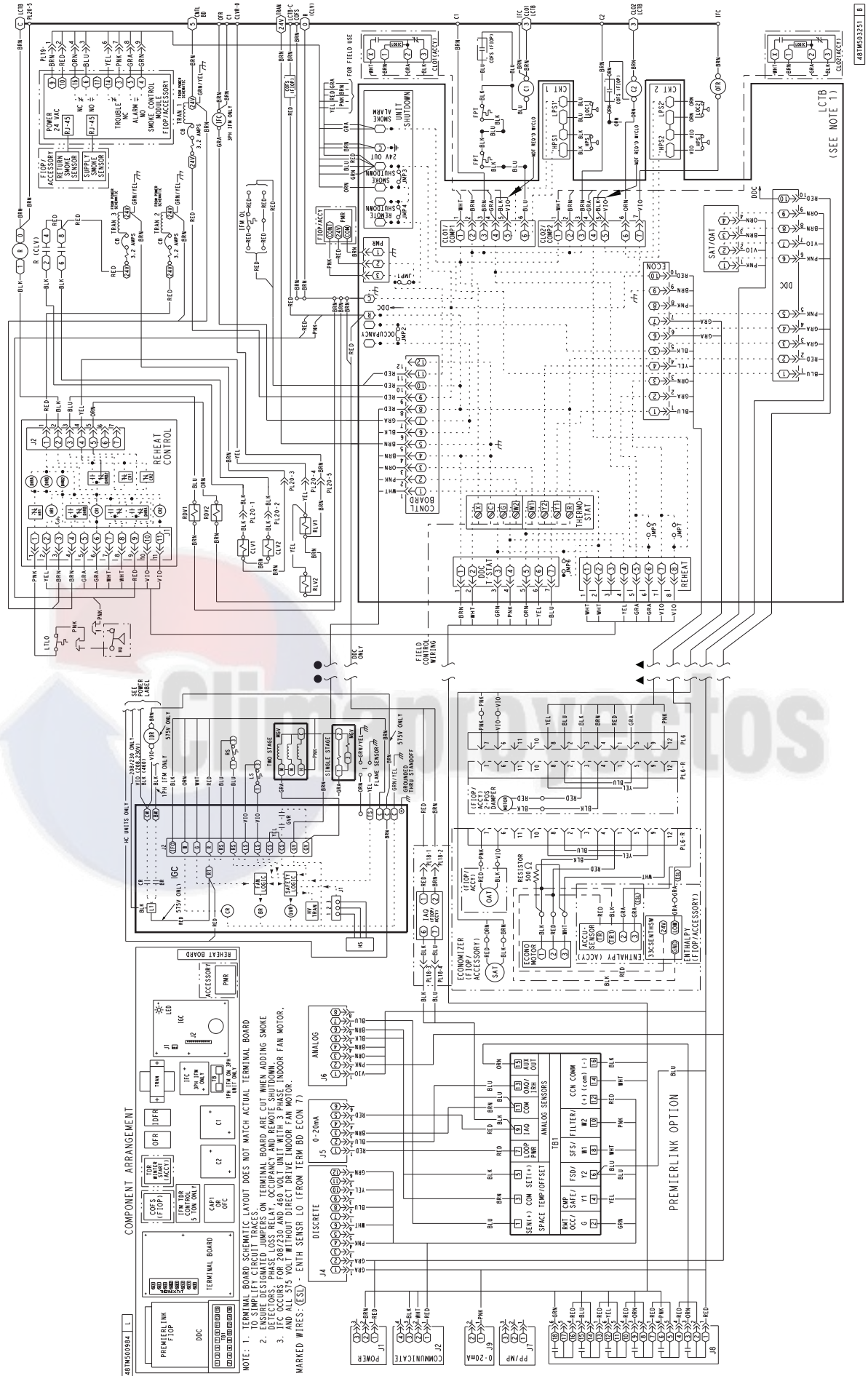

Fig. 13 - Typical Field Control Wiring 48/50TC/HC — PremierLink Units with Humidi-MiZer®

YAC CONTROL 208/230V, 460V, 575V-3-60
7.5-8.5 TON MID-TIER, W/DEHUMIDIFICATION

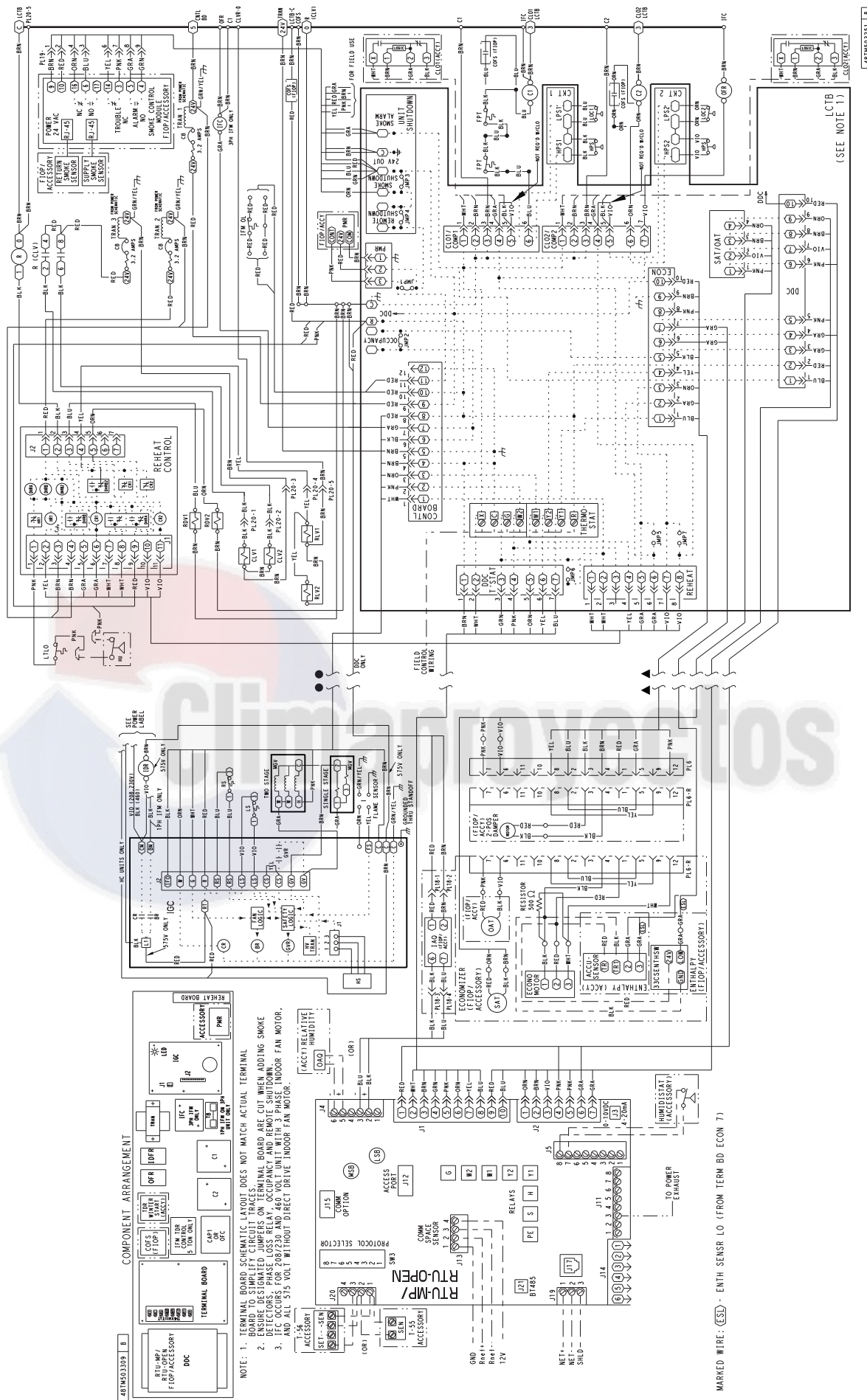

Fig. 14 - Typical Field Control Wiring 48/50TC/HC — RTU Open Units with Humidi-MiZer®

48-50TCHC-01XA

48HC 08, 09 208/230V, 460V, 575V
COMFORTLINK CONTROL

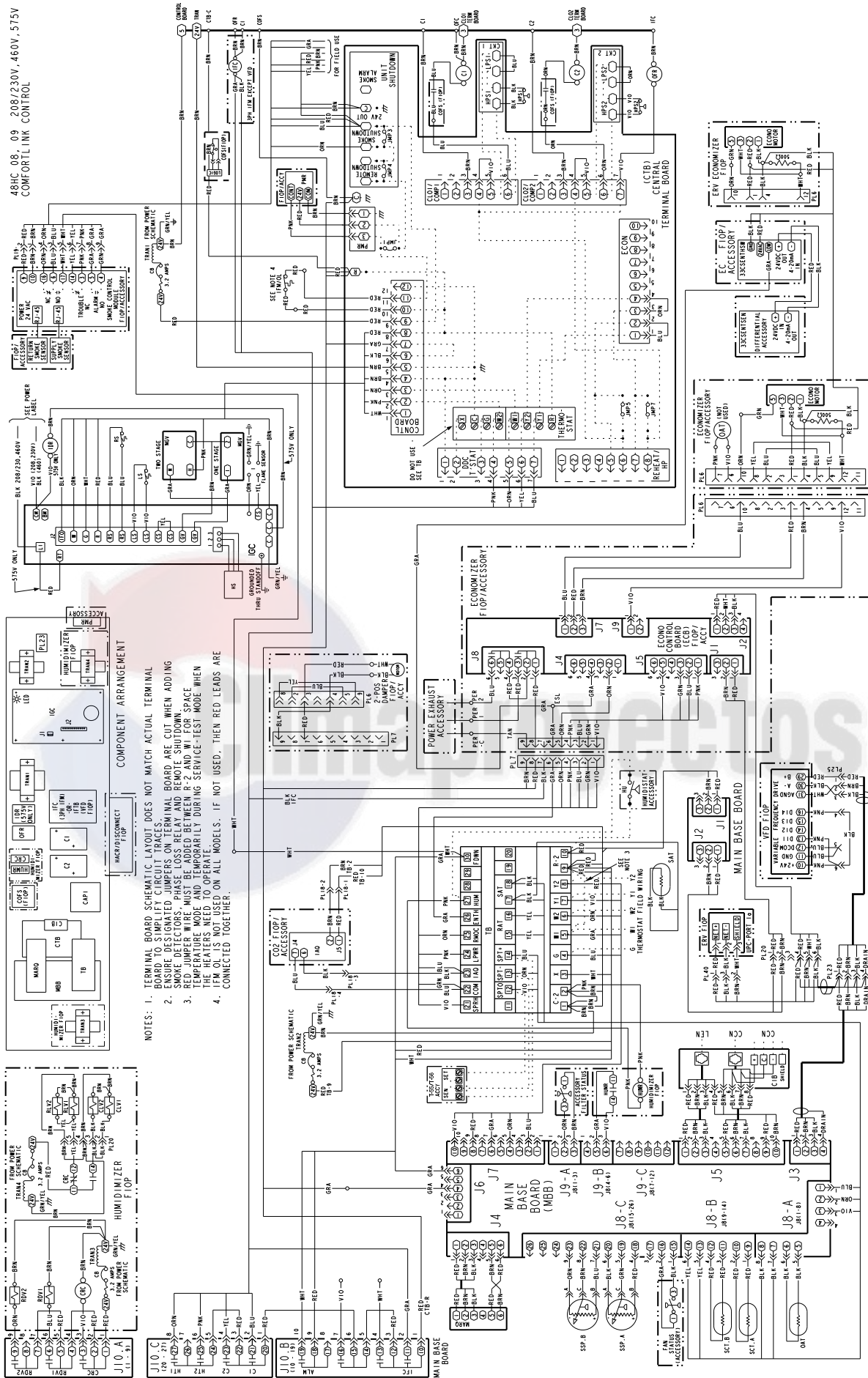

Fig. 15 - Typical Field Control Wiring 48/50HC — ComfortLink Units with Humidi-MiZer®



