

3 - 6 TON PACKAGED AIR CONDITIONER 13 SEER / UP TO 11.3 EER

6-TON WITH TWO-SPEED BLOWER MOTOR AND
TWO-STAGE COMPRESSOR UP TO 15.5 IEER

COOLING CAPACITY: 34,600 — 71,000 BTU/H

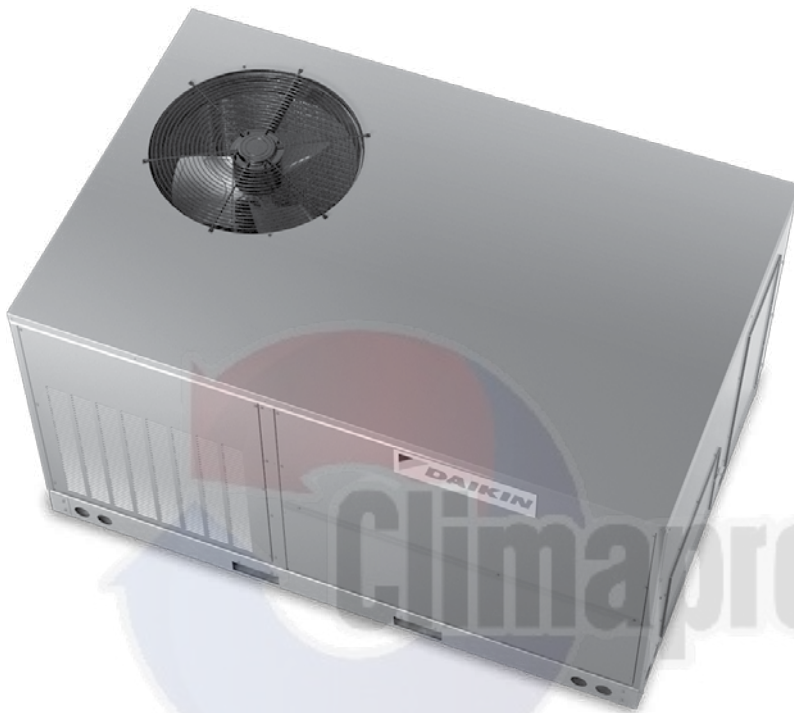

■ Contents

Nomenclature.....	2
Product Specifications.....	4
Expanded Cooling Data	8
Airflow Data	18
Heat Kit Electrical Data	25
Dimensions	30
Wiring Diagrams	34
Accessories	39

■ Standard Features

- High-efficiency scroll compressor
- Copper tube/aluminum fin coils
- High- and low-pressure switches
- Contactor with lugs
- High-capacity, steel-cased filter drier
- Heater kits with single-point entry
- 24-volt terminal strip
- Convertible airflow orientation
- Easy to service
- Built-in filter rack with standard 2" filters
- Bottom utility entry
- AHRI Certified; ETL Listed
- 3-6 Tons with single speed blower motor units meet the performance specified in Table 6.8.1A of ASHRAE Standard 90.1-2010
- 6-Ton with two-speed blower motor and two-stage compressor meet the performance specified as of 1/1/2016 in Table 6.8.1-1 of ASHRAE Standard 90.1-2013

■ Cabinet Features

- Heavy-gauge, galvanized-steel cabinet with UV-resistant powder-paint finish
- Full Perimeter Rail
- Sloped drain pan



* Complete warranty details available from your local dealer or at www.daikincomfort.com.

	D	C	C	060	020	3	B	*	*	*	A	*
	1	2	3	4,5,6	7,8,9	10	11	12	13	14	15	16
REVISION LEVELS												
Major & Minor												
FACTORY-INSTALLED OPTIONS												
BRAND	D Daikin											
CONFIGURATION	C Standard Efficiency T High Efficiency (3-5 Tons)											
APPLICATION	C Cooling G Gas Heat H Heat Pump											
NOMINAL COOLING CAPACITY												
036	3 Tons	102	8½ Tons	300	25 Tons							
048	4 Tons	120	10 Tons									
060	5 Tons	150	12½ tons									
072	6 Tons	180	15 Tons									
090	7½ Tons	240	20 Tons									
NOMINAL HEATING CAPACITY												
Gas/Electric	A/C H/P		Factory-Installed Electric Heat									
045	45,000 BTU/h	XXX	No Heat									
090	90,000 BTU/h	010	10 kW	030	30 kW							
115	115,000 BTU/h	015	15 kW	031	30 kW							
140	140,000 BTU/h	016	15 kW	045	45 kW							
210	210,000 BTU/h	018	18 kW	046	45 kW							
350	350,000 BTU/h	020	20 kW	060	60 kW							
400	400,000 BTU/h	025	25 kW									
See product specifications for heat size(s) available for each capacity.												
VOLTAGE												
1	208-230/1/60	4	460/3/60									
3	208-230/3/60	7	575/3/60									
SUPPLY FAN/DRIVE TYPE/MOTOR												
B	Belt Drive (single speed)	V	Two-Speed Belt Drive (also designates									
D	Direct Drive (3-5 tons)		6-ton with two-stage compressor)									
FACTORY-INSTALLED OPTIONS												
X	No Options											
A	Ultra Low-Leak Downflow Economizer ¹											
H	Disconnect Switch (non-fused)											
J	Ultra Low-Leak Downflow Economizer ¹ ; Disconnect Switch (non-fused)											
V	Low-Leak Downflow Economizer ²											
W	Low-Leak Downflow Economizer ² ; Disconnect Switch (non-fused)											
Note: Not all options available for all products.												
¹ Please contact RRS Rooftop Systems directly if Power Exhaust is required.												
² Please use part number DPE36722 / DPE36724 / DPE36727 if Power Exhaust is required.												
FACTORY-INSTALLED OPTIONS												
X	Standard Aluminized Heat Exchanger											
S	Stainless-Steel Heat Exchanger											
D	Hinged Panels (3-12½ Tons)											
K	Stainless-Steel Heat Exchanger; Hinged panels (3-12½ Tons)											

FACTORY-INSTALLED OPTIONS

- **Stainless-Steel Heat Exchanger (DCG units only):** A tubular heat exchanger made of 409-type stainless steel is installed in the unit.
- **Low-Ambient Kit:** Allows for cooling operation at lower outdoor temperatures. On the 3- to 6-ton units, cooling operation is extended from 60°F ambient temperature to 35°F outside air temperature. On 7½ -20 ton units, cooling operation is extended from 35°F ambient temperature to 0°F outside air temperature. For 25 ton units, cooling operation is extended from 24°F ambient temperature to 0°F outside air temperature.
- **Economizers (Downflow):** Based on air conditions, can provide outside air to cool the space.
- **Electric Heat Kits (DCC/DTC and DCH/DTH units only):** Available in all voltage options.
- **Non-powered Convenience Outlet:** A 120V, 15A, GFCI outlet makes it easier for technicians to service the unit once an electrician runs power to the outlet.
- **Powered Convenience Outlet:** A 120V, 15A, GFCI outlet powered with a transformer built into the unit. When a factory-installed powered convenience outlet is installed in the equipment, the unit MCA (Min. Circuit Ampacity) will increase by 7.5A for 208/230V units, increase by 3.75A for 460V units, and by 3A for 575V units. The MOP (Max. Overcurrent Protection) device must be sized accordingly.
- **Disconnect Switch (non-fused; 3-phase units only):** A disconnect switch is installed in the unit and factory wiring will be complete from the switch to the unit. Please note that for air conditioning (DCC units) and heat pump models (DCH units), the appropriate electric heat kit must be ordered to be factory-installed along with the disconnect switch (non-fused) when it is ordered. Please note that for models with a powered convenience outlet option and a disconnect switch (non-fused) option, the power to the powered convenience outlet will be shut off when the disconnect switch (non-fused) is in the off position.
- **Return Air and/or Supply Air Smoke Detectors:** Return air and/or supply air smoke detectors are installed in the unit.
- **Hinged Access Panels:** Allows access to unit's major components. Combined with latches for easy access to control box, compressor, filters and blower motor. Available on 3-12½ Tons units.
- **Two-speed indoor fan blower models** are available on 6, 7½, 8½, 10, 12½, 15, 20 & 25 ton units. Section 6.4.3.10.b of ASHRAE Standard 90.1-2010 and Section 6.5.3.2.1.a of ASHRAE Standard 90.1-2013 require a minimum of two fan speeds. Section 140.4(m)1 of California Energy Commission Title 24 2013 contains a similar provision. When the units with the two-speed indoor fan blowers operate on a call for the first stage of cooling, the fan operates at low speed, which is 66% of full speed. When the units operate on a call for the second stage of cooling, the fan operates at full speed. In heating operation, the fan operates at full speed. During ventilation operation, the fan operates at low speed.



	DCC036 ***3D***A*	DCC036 ***3B***A*	DCC036 ***4B***A*	DCC036 ***7B***A*
COOLING CAPACITY				
Total BTU/h	34,600	34,600	34,600	34,600
Sensible BTU/h	25,600	25,600	25,600	25,600
SEER / EER	13 / 11.0	13 / 11.0	13 / 11.0	13 / 11.0
Decibels	78	78	78	78
ARI Reference #s	6345730	6345730	6345731	6345732
EVAPORATOR MOTOR / COIL				
Motor Type	Direct Drive	Belt Drive	Belt Drive	Belt Drive
Indoor Nominal CFM	1,200	1,200	1,200	1,200
Motor Speed Tap (Cooling)	Low Speed	---	---	---
Indoor motor FLA (Cooling)	2.50	3.8	1.9	2.3
Horsepower - RPM	½ - 890	1.0 - 1725	1.0 - 1725	1.5 - 1725
Piston Size (Cooling)	0.068	0.068	0.068	0.068
Filter Size (Qty)	(1) 24" x 24" x 2"	(1) 24" x 24" x 2"	(1) 24" x 24" x 2"	(1) 24" x 24" x 2"
Drain Size (NPT)	¾"	¾"	¾"	¾"
R-410A Refrigerant Charge (oz.)	83	83	83	125
Evaporator Coil Face Area (ft ²)	5.4	5.4	5.4	5.4
Rows Deep/ Fins per Inch	3 / 16	3 / 16	3 / 16	3 / 16
EVAPORATOR FAN				
Standard Direct Drive (D x W) HP	(10" X 9") ½	---	---	---
Standard Belt Drive (D x W) HP	---	(11" X 10") 1	(11" X 10") 1	(11" X 10") 1½
High-Static Belt Drive (D x W) HP	---	(11" X 10") 1½	(11" X 10") 1½	(11" X 10") 1½
# of Wheels (D x W)	---	1 (11" x 10")	1 (11" x 10")	1 (11" x 10")
Motor Sheave	---	1VL40 X ¾	1VL40 X ¾	1VL40 X ¾
Blower Sheave / Belt	---	AK69 x 1 / AX52	AK69 x 1 / AX52	AK69 x 1 / AX52
CONDENSER FAN / COIL				
Quantity of Condenser Fan Motors	1	1	1	1
Horsepower - RPM	¼ / 1,090	¼ / 1,090	¼ - 890	¼ - 1,075
Fan Diameter / # Fan Blades	22 / 4	22 / 4	22 / 4	22 / 4
Outdoor Nominal CFM	3,800	3,800	3,800	3,800
Face Area (ft ²)	17.0	17.0	17.0	13.0
Rows Deep/ Fins per Inch	1 / 24	1 / 24	1 / 24	2 / 16
COMPRESSOR				
Quantity / Type	1 / Scroll	1 / Scroll	1 / Scroll	1 / Scroll
Stage	Single	Single	Single	Single
Compressor RLA / LRA	10.5 / 73.0	10.5 / 73.0	5.8 / 38.0	3.8 / 36.5
ELECTRICAL DATA				
Voltage-Phase-Frequency	208/230-3-60	208/230-3-60	460-3-60	575-3-60
Indoor Blower HP / FLA	½ / 2.5	1 / 3.8	1 / 1.9	1.5 / 2.3
Outdoor Fan HP / FLA	¼ / 1.4	¼ / 1.4	¼ / 0.8	0.60
Total Unit Amps	14.35	15.65	8.47	6.68
Min. Circuit Ampacity ¹	17	18	10	8
Max. Overcurrent Protection (amps) ²	25	25	15	15
Power Supply Conduit Hole	1.125"	1.125"	1.125"	1.125"
Low Voltage Conduit Hole	½"	½"	½"	½"
OPERATING WEIGHT (LBS)				
	500	500	500	500
SHIP WEIGHT (LBS)				
	525	525	525	525

¹ Wire size should be determined in accordance with National Electrical Codes. Extensive wire runs will require larger wire sizes.

² May use fuses or HACR-type circuit breakers of the same size as noted.

NOTES

- Always check the S&R plate for electrical data on the unit being installed.
- When a factory-installed powered convenience outlet is installed in the equipment, the unit MCA (Min. Circuit Ampacity) will increase by 7.5A for 208/230V units, increase by 3.75A for 460V units, and by 3A for 575V units. The MOP (Max. Overcurrent Protection) device must be sized accordingly.

	DCC048 ***3D***A*	DCC048 ***3B***A*	DCC048 ***4B***A*	DCC048 ***7B***A*
COOLING CAPACITY				
Total BTU/h	45,500	45,500	45,500	45,500
Sensible BTU/h	35,000	35,000	35,000	35,000
SEER / EER	13.0 / 11.3	13.0 / 11.3	13.0 / 11.3	13.0 / 11.3
Decibels	78	78	78	78
ARI Reference #s	6345734	6345734	6345735	6345736
EVAPORATOR MOTOR / COIL				
Motor Type	Direct Drive	Belt Drive	Belt Drive	Belt Drive
Indoor Nominal CFM	1,600	1,600	1,600	1,600
Motor Speed Tap (Cooling)	Medium	--	--	--
Indoor Motor FLA (Cooling)	2.87	3.8	1.9	2.3
Horsepower - RPM	½ -1,000	1.0 - 1,725	1.0 - 1,725	1.5 - 1,725
Piston Size (Cooling)	0.076	0.076	0.076	0.076
Filter Size (Qty)	(4) 14" x 20" x 2"	(4) 14" x 20" x 2"	(4) 14" x 20" x 2"	(4) 14" x 20" x 2"
Drain Size (NPT)	¾"	¾"	¾"	¾"
R-410A Refrigerant Charge (oz.)	103	103	103	105
Evaporator Coil Face Area (ft²)	7.0	7.0	7.0	7.0
Rows Deep / Fins per Inch	4 / 16	4 / 16	4 / 16	4 / 16
BELT DRIVE EVAP FAN DATA				
# of Wheels (D x W)	---	1 (11" x 10")	1 (11" x 10")	1 (11" x 10")
Motor Sheave	---	VL44 X 5/8	VL44 X 5/8	VL44 X 5/8
Blower Sheave / Belt	---	AK66 x 1 / AX52	AK66 X 1	AK66 X 1
CONDENSER FAN / COIL				
Quantity of Condenser Fan Motors	1	1	1	1
Horsepower - RPM	¼ - 1,090	¼ - 1,090	¼ - 1,090	¼ - 1,075
Fan Diameter / # Fan Blades	22 / 4	22 / 4	22 / 4	22 / 4
Outdoor Nominal CFM	3,800	3,800	3,800	3,800
Face Area (ft²)	17	17	17	17
Rows Deep / Fins per Inch	1 / 24	1 / 24	1 / 24	1 / 24
COMPRESSOR				
Quantity / Stage	1 / Single	1 / Single	1 / Single	1 / Single
Type	Scroll	Scroll	Scroll	Scroll
Compressor RLA / LRA	13.1/ 83.1	13.1/ 83.1	6.1/ 41	4.4/ 33
ELECTRICAL DATA				
Voltage-Phase-Frequency	208/230-3-60	208/230-3-60	460-3-60	575-3-60
Outdoor Fan FLA	1.40	1.40	0.80	0.60
Total Unit Amps	17.4	18.3	8.8	7.3
Min. Circuit Ampacity ¹	21	22	10	8
Max. Overcurrent Protection (amps) ²	30	30	15	15
Power Supply Conduit Hole	1.125"	1.125"	1.125"	1.125"
Low-Voltage Conduit Hole	½"	½"	½"	½"
OPERATING WEIGHT (LBS)				
	535	535	535	535
SHIP WEIGHT (LBS)				
	560	560	560	560

¹ Wire size should be determined in accordance with National Electrical Codes. Extensive wire runs will require larger wire sizes.

² May use fuses or HACR-type circuit breakers of the same size as noted.

NOTES

- Always check the S&R plate for electrical data on the unit being installed.
- When a factory-installed powered convenience outlet is installed in the equipment, the unit MCA (Min. Circuit Ampacity) will increase by 7.5A for 208/230V units, increase by 3.75A for 460V units, and by 3A for 575V units. The MOP (Max. Overcurrent Protection) device must be sized accordingly.

	DCC060 ***3D***A*	DCC060 ***3B***A*	DCC060 ***4B***A*	DCC060 ***7B***A*
COOLING CAPACITY				
Total BTU/h	58,000	58,000	58,000	58,000
Sensible BTU/h	42,800	42,800	42,800	42,800
SEER / EER	13 / 11.1	13 / 11.1	13 / 11.1	13 / 11.1
Decibels	78	78	78	78
ARI Reference #s	6345738	6345738	6345739	6345740
EVAPORATOR MOTOR / COIL				
Motor Type	Direct	Belt	Belt	Belt
Indoor Nominal CFM	2,000	2,000	2,000	2,000
Expansion Device	Piston	Piston	Piston	Piston
Piston Size (Cooling)	0.086	0.086	0.086	0.086
Filter Size (")	(4) 14 x 20 x 2	(4) 14 x 20 x 2	(4) 14 x 20 x 2	(4) 14 x 20 x 2
Drain Size (NPT)	¾"	¾"	¾"	¾"
R-410A Refrigerant Charge (oz.)	100.8	100.8	100.8	100.8
Face Area (ft ²)	7.8	7.8	7.8	7.8
Rows Deep/ Fins per Inch	4 / 16	4 / 16	4 / 16	4 / 16
Tube Diameter - Material	5/16 - Copper	5/16 - Copper	5/16 - Copper	5/16 - Copper
EVAPORATOR FAN				
Standard Direct Drive (D x W) HP	(11" X 10") 1	---	---	---
Standard Belt Drive (D x W) HP	---	(11" X 10") 1	(11" X 10") 1	(11" X 10") 1½
High-Static Belt Drive (D x W) HP	---	(11" X 10") 1½	(11" X 10") 1½	(11" X 10") 1½
BELT DRIVE EVAP FAN DATA				
# of Wheels (D x W)	---	1 (11" x 10")	1 (11" x 10")	1 (11" x 10")
Motor Sheave	---	VL44 x ¾"	VL44 x ¾"	VL44 x ¾"
Blower Sheave / Belt	---	AK61 x 1 / AX55	AK61 x 1 / AX55	AK61 x 1 / AX55
CONDENSER FAN / COIL				
Horsepower / RPM	¾ / 1,090	¾ / 1,090	¾ / 1,090	¾ / 1,075
Fan Diameter / # Fan Blades	22 / 4	22 / 4	22 / 4	22 / 4
Outdoor Nominal CFM	3,800	3,800	3,800	3,800
Face Area (ft ²)	13.0	13.0	13.0	13.0
Rows Deep/ Fins per Inch	2 / 27	2 / 27	2 / 27	2 / 27
Tube Diameter - Material	5MM - Copper	5MM - Copper	5MM - Copper	5MM - Copper
COMPRESSOR				
Quantity / Stage	1 / Scroll	1 / Scroll	1 / Scroll	1 / Scroll
Type	Single	Single	Single	Single
Compressor RLA / LRA	16 / 110	16 / 110	7.8 / 52	5.7 / 38.9
ELECTRICAL DATA				
Voltage-Phase-Frequency	208/230-3-60	208/230-3-60	460-3-60	575-3-60
Indoor Blower HP / FLA	1.0 / 7.6	1.0 / 3.8	1.0 / 1.9	1.5 / 2.3
Indoor Blower LRA	---	24	12	12
Outdoor Fan HP / FLA	¾ / 1.40	¾ / 1.40	¾ / 0.80	¾ / 0.60
Min. Circuit Ampacity ¹	29	25	12	10
Max. Overcurrent Protection (amps) ²	45	40	20	15
Power Supply Conduit Hole	1.125"	1.125"	1.125"	1.125"
Low-Voltage Conduit Hole	½"	½"	½"	½"
OPERATING WEIGHT (LBS)				
	580	580	580	580
SHIP WEIGHT (LBS)				
	605	605	605	605

¹ Wire size should be determined in accordance with National Electrical Codes. Extensive wire runs will require larger wire sizes.

² May use fuses or HACR-type circuit breakers of the same size as noted.

NOTES

- Always check the S&R plate for electrical data on the unit being installed.
- When a factory-installed powered convenience outlet is installed in the equipment, the unit MCA (Min. Circuit Ampacity) will increase by 7.5A for 208/230V units, increase by 3.75A for 460V units, and by 3A for 575V units. The MOP (Max. Overcurrent Protection) device must be sized accordingly.

	DCC072 ***3B***A*	DCC072 ***3V***A*	DCC072 ***4B***A*	DCC072 ***4V***A*	DCC072 ***7B***A*	DCC072 ***7V***A*
COOLING CAPACITY						
Total BTU/h	71,000	70,000	71,000	70,000	71,000	70,000
Sensible BTU/h	49,800	51,000	49,800	51,000	49,800	51,000
EER / IEER	11.2 / 11.4	11.3/15.5	11.2 / 11.4	11.3/15.5	11.2 / 11.4	11.3/15.5
Decibels	78.0	78.0	78.0	78.0	78.0	78.0
AHRI Number	6345708	8952850	6345708	8952850	6345708	8952850
EVAPORATOR MOTOR / COIL						
Motor Type	Belt Drive	2-Speed Belt Drive	Belt Drive	2-Speed Belt Drive	Belt Drive	2-Speed Belt Drive
Wheel (D x W)	1 (11" x 10")	1 (11" x 10")	1 (11" x 10")	1 (11" x 10")	1 (11" x 10")	1 (11" x 10")
Indoor Nominal CFM	2,350	2,250	2,350	2,250	2,350	2,250
Indoor Motor FLA (Cooling)	5.0	6.0	2.5	2.9	2.3	2.4
Horsepower - RPM	1.5-1,725	2.0-1,725	1.5-1,725	2.0-1,725	1.5-1,725	2.0-1,725
Piston Size (Cooling)	0.094	TXV	0.094	TXV	0.094	TXV
Filter Size	(4) 16" x 20" x 2"	(4) 16" x 20" x 2"	(4) 16" x 20" x 2"	(4) 16" x 20" x 2"	(4) 16" x 20" x 2"	(4) 16" x 20" x 2"
Drain Size (NPT)	¾"	¾"	¾"	¾"	¾"	¾"
R-410A Refrigerant Charge Cir #1(oz.)	146.0	146.0 OZ	146.0	146 oz.	146.0	146 oz.
Evaporator Coil Face Area (ft ²)	8.9	8.9	8.9	8.9	8.9	8.9
Rows Deep/ Fins per Inch	4/ 16	4/ 16	4/ 16	4/ 16	4/ 16	4/ 16
Motor Sheave	VL44 X 7/8	VL44 X 7/8	VL44 X 7/8	VL44 X 7/8	VL44 X 7/8	VL44 X 7/8
Blower Sheave	AK59 X 1	AK59 X 1	AK59 X 1	AK59 X 1	AK59 X 1	AK59 X 1
Belt	AX53	AX53	AX53	AX53	AX53	AX53
CONDENSER FAN / COIL						
Quantity of condenser Fan Motors	1	1	1	1	1	1
Horsepower - RPM	½ - 1,075	½ - 1,075	½ - 1,075	½ - 1,075	½ - 1,075	½ - 1,075
Fan Diameter / # Fan Blades	22/ 4	22/ 4	22/ 4	22/ 4	22/ 4	22/ 4
Outdoor Nominal CFM	4,200	4,200	4,200	4,200	4,200	4,200
Face Area (ft ²)	19	19	19	19	19	19
Rows Deep/ Fins per Inch	2 / 27	2 / 27	2 / 27	2 / 27	2 / 27	2 / 27
COMPRESSOR						
Quantity / Type	1 / Scroll	1 / Scroll	1 / Scroll	1 / Scroll	1 / Scroll	1 / Scroll
Stage	Single	Two	Single	Two	Single	Two
Compressor RLA / LRA	19/123.0	17.6/136	9.7/62.0	8.5/66.1	7.4/50.0	6.3/55.3
ELECTRICAL DATA						
Voltage/Phase/ Frequency	208-230/3/60	208-230/3/60	460/3/60	460/3/60	575/3/60	575/3/60
Quantity of Compressors	1	1	1	1	1	1
Belt-Driven Standard Max Static	1.0	1.0	1.0	1.0	1.0	1.0
Outdoor Fan FLA	1.90	2.00	1.20	0.90	0.90	0.70
Total Unit Amps	25.9	25.6	13.4	12.3	10.6	9.4
Min. Circuit Ampacity ¹	31	30	16	14.4	12	11.0
Max. Overcurrent Protection (amps) ²	45	45	25	20	15	15.0
Entrance Power Supply	1.125"	1.125"	1.125"	1.125"	1.125"	1.125"
Entrance Control Voltage	½"	½"	½"	½"	½"	½"
OPERATING WEIGHT (LBS)	640	640	640	640	640	640
SHIP WEIGHT (LBS)	665	665	665	665	665	665

¹ Wire size should be determined in accordance with National Electrical Codes. Extensive wire runs will require larger wire sizes.

² May use fuses or HACR-type circuit breakers of the same size as noted.

NOTES • Always check the S&R plate for electrical data on the unit being installed.

- When a factory-installed powered convenience outlet is installed in the equipment, the unit MCA (Min. Circuit Ampacity) will increase by 7.5A for 208/230V units, increase by 3.75A for 460V units, and by 3A for 575V units. The MOP (Max. Overcurrent Protection) device must be sized accordingly.

IDB	AIRFLOW	OUTDOOR AMBIENT TEMPERATURE												105°F												115°F																
		65°F						75°F						85°F						95°F						105°F						115°F										
		59	63	67	71	75	79	59	63	67	71	75	79	59	63	67	71	75	79	59	63	67	71	75	79	59	63	67	71	75	79	59	63	67	71	75	79					
70	1350	MBh	33.9	35.1	38.5	-	33.1	34.3	37.6	-	32.3	33.5	36.7	-	31.5	32.7	35.8	-	30.0	31.1	34.0	-	27.8	28.8	31.5	-	31.5	32.7	35.8	-	0.82	0.69	0.48	-	0.83	0.69	0.48	-	16	14	10	-
		S/T	0.72	0.60	0.42	-	0.75	0.63	0.43	-	0.77	0.64	0.44	-	0.79	0.66	0.46	-	0.82	0.69	0.48	-	0.83	0.69	0.48	-	0.82	0.69	0.48	-	17	15	11	-	17	15	11	-	3.11	3.17	3.27	-
	ΔT	17	14	11	-	17	15	11	-	17	15	11	-	17	15	11	-	17	15	11	-	17	15	11	-	17	15	11	-	3.01	3.07	3.17	-	10.6	10.8	11.0	-	11.1	11.3	11.6	-	
	kW	2.44	2.48	2.56	-	2.61	2.66	2.74	-	2.76	2.82	2.90	-	2.90	2.95	3.05	-	2.99	3.05	3.14	-	3.08	3.15	3.25	-	2.90	2.95	3.05	-	10.5	10.7	11.0	-	361	388	410	-	398	429	453	-	
	Amps	8.5	8.7	8.9	-	9.0	9.2	9.4	-	9.6	9.8	10.0	-	10.1	10.3	10.5	-	10.5	10.7	11.0	-	10.7	11.2	11.5	-	10.1	10.3	10.5	-	361	388	410	-	130	138	150	-	134	143	156	-	
	HIPR	221	237	251	-	247	266	281	-	281	303	320	-	321	345	364	-	321	342	361	-	357	384	425	-	321	345	364	-	361	388	410	-	394	425	448	-	394	429	453	-	
	LO PR	107	114	124	-	113	120	131	-	118	125	137	-	124	131	144	-	124	130	142	-	128	136	149	-	124	131	144	-	130	138	150	-	133	141	154	-	134	143	156	-	
	MBh	32.9	34.1	37.4	-	32.2	33.3	36.5	-	31.4	32.5	35.6	-	30.6	31.7	34.8	-	29.1	30.2	33.0	-	26.9	27.9	30.6	-	30.6	31.7	34.8	-	0.76	0.63	0.44	-	0.79	0.66	0.45	-	16	14	11	-	
	S/T	0.69	0.58	0.40	-	0.71	0.60	0.41	-	0.73	0.61	0.42	-	0.76	0.63	0.44	-	0.79	0.66	0.45	-	0.79	0.66	0.46	-	0.76	0.63	0.44	-	18	15	11	-	18	15	11	-	3.08	3.15	3.25	-	
	ΔT	17	15	11	-	18	15	12	-	18	15	12	-	18	15	12	-	18	15	12	-	18	15	12	-	18	15	12	-	2.99	3.05	3.14	-	11.0	11.2	11.5	-	11.0	11.2	11.5	-	
kW	2.42	2.47	2.54	-	2.59	2.64	2.72	-	2.74	2.80	2.88	-	2.87	2.93	3.02	-	2.87	2.93	3.02	-	2.92	2.98	3.07	-	2.87	2.93	3.02	-	10.5	10.7	11.0	-	357	384	406	-	394	425	448	-		
Amps	8.5	8.6	8.8	-	8.9	9.1	9.3	-	9.5	9.7	9.9	-	10.0	10.2	10.4	-	10.0	10.2	10.4	-	10.3	10.5	10.7	-	10.0	10.2	10.4	-	357	384	406	-	128	136	149	-	133	141	154	-		
HIPR	218	235	248	-	245	264	278	-	279	300	317	-	317	342	361	-	317	342	361	-	357	384	425	-	317	342	361	-	357	384	406	-	394	425	448	-	394	429	453	-		
LO PR	106	113	123	-	112	119	130	-	116	124	135	-	122	130	142	-	122	130	142	-	128	136	149	-	122	130	142	-	128	136	149	-	133	141	154	-	134	143	156	-		
MBh	30.4	31.5	34.5	-	29.7	30.8	33.7	-	29.0	30.0	32.9	-	28.3	29.3	32.1	-	26.9	27.8	30.5	-	24.9	25.8	28.2	-	28.3	29.3	32.1	-	0.73	0.61	0.42	-	0.76	0.63	0.44	-	17	14	11	-		
S/T	0.67	0.56	0.38	-	0.69	0.58	0.40	-	0.71	0.59	0.41	-	0.73	0.61	0.42	-	0.76	0.63	0.44	-	0.76	0.63	0.44	-	0.73	0.61	0.42	-	18	15	12	-	18	15	12	-	3.01	3.07	3.17	-		
ΔT	18	15	12	-	18	16	12	-	18	16	12	-	18	16	12	-	18	15	12	-	18	15	12	-	18	16	12	-	2.92	2.98	3.07	-	10.7	10.9	11.2	-	10.7	10.9	11.2	-		
kW	2.37	2.41	2.48	-	2.53	2.58	2.66	-	2.68	2.73	2.81	-	2.81	2.86	2.95	-	2.81	2.86	2.95	-	2.92	2.98	3.07	-	2.81	2.86	2.95	-	10.3	10.5	10.7	-	346	373	394	-	383	412	435	-		
Amps	8.3	8.4	8.6	-	8.8	8.9	9.1	-	9.3	9.5	9.7	-	9.8	10.0	10.2	-	9.8	10.0	10.2	-	10.3	10.5	10.7	-	9.8	10.0	10.2	-	346	373	394	-	124	132	144	-	129	137	149	-		
HIPR	212	228	241	-	238	256	270	-	270	291	307	-	308	331	350	-	308	331	350	-	346	373	394	-	308	331	350	-	346	373	394	-	383	412	435	-	383	412	435	-		
LO PR	103	109	120	-	109	116	126	-	113	120	131	-	119	126	138	-	119	126	138	-	124	132	144	-	119	126	138	-	124	132	144	-	129	137	149	-	137	149	161	-		
75	1350	MBh	34.5	35.5	38.4	41.2	33.7	34.7	37.5	40.3	32.9	33.8	36.6	39.3	32.1	33.0	35.7	38.4	30.5	31.4	34.0	36.4	28.2	29.1	31.5	33.8	32.1	33.0	35.7	38.4	0.94	0.84	0.63	0.41	0.94	0.84	0.63	0.41	18	17	14	9
		S/T	0.82	0.74	0.56	0.36	0.85	0.76	0.58	0.37	0.87	0.78	0.59	0.38	0.90	0.81	0.61	0.39	0.94	0.84	0.63	0.41	0.94	0.84	0.63	0.41	0.90	0.81	0.61	0.39	20	18	15	10	20	19	15	10	18	17	14	9
	ΔT	19	18	15	10	20	18	15	10	20	18	15	10	20	19	15	10	20	19	15	10	20	19	15	10	20	19	15	10	21	19	15	10	21	19	15	10	20	19	15	10	
	kW	2.46	2.50	2.58	2.65	2.63	2.68	2.76	2.85	2.78	2.84	2.93	3.02	2.92	2.92	2.98	3.07	3.17	3.03	3.10	3.19	3.29	3.13	3.20	3.30	3.40	2.92	2.98	3.07	3.17	10.6	10.8	11.1	11.5	10.6	10.8	11.1	11.5	11.1	11.4	11.7	12.0
	Amps	8.6	8.7	8.9	9.2	9.1	9.2	9.5	9.7	9.6	9.8	10.1	10.4	10.1	10.3	10.6	10.9	11.5	10.6	10.8	11.1	11.5	11.1	11.4	11.7	12.0	10.1	10.3	10.6	10.9	364	392	414	432	364	392	414	432	402	433	457	477
	HIPR	223	240	253	264	250	269	284	296	284	306	323	337	324	348	368	384	384	364	392	414	432	402	433	457	477	324	348	368	384	364	392	414	432	364	392	414	432	402	433	457	477
	LO PR	108	115	126	134	114	122	133	141	119	126	138	147	125	133	145	154	154	131	139	152	162	135	144	157	167	125	133	145	154	131	139	152	162	131	139	152	162	135	144	157	167
	MBh	33.5	34.5	37.3	40.0	32.7	33.7	36.4	39.1	31.9	32.9	35.6	38.2	31.1	32.1	34.7	37.2	37.2	29.6	30.5	33.0	35.4	27.4	28.2	30.5	32.8	31.1	32.1	34.7	37.2	29.6	30.5	33.0	35.4	29.6	30.5	33.0	35.4	27.4	28.2	30.5	32.8
	S/T	0.78	0.70	0.53	0.34	0.81	0.73	0.55	0.35	0.83	0.75	0.56	0.36	0.86	0.77	0.58	0.37	0.89	0.80	0.60	0.39	0.90	0.81	0.61	0.39	0.86	0.77	0.58	0.37	0.89	0.80	0.60	0.39	0.89	0.80	0.60	0.39	0.90	0.81	0.61	0.39	
	ΔT	20	19	15	10	20	19	15	11	20	19	15	11	20	19	15	11	20	19	15	11	20	19	15	10	21	19	15	11	21	19	15	11	20	19	15	11	19	17	14	10	
kW	2.44	2.49	2.56	2.63	2.61	2.66	2.74	2.82	2.76	2.82	2.90	2.99	2.90	2.90	2.96	3.05	3.14	3.01	3.07	3.17	3.27	3.11	3.17	3.27	3.38	2.90	2.96	3.05	3.14	10.6	10.8	11.1	11.4	10.6	10.8	11.1	11.4	11.1	11.3	11.6	11.9	
Amps	8.5	8.7	8.9	9.1	9.0	9.2	9.4	9.6	9.6	9.8	10.0	10.3	10.1	10.3	10.5	10.8	11.4	10.6	10.8	11.1	11.4	11.1	11.3	11.6	11.9	10.1	10.3	10.5	10.8	361	388	410	427	361	388	410	427	399	429	453	472	
HIPR	221	237	251	261	248	266	281	293	281	303	320	334	321	345	364	380	380	361	388	410	427	399	429	453	472	321	345	364	380	361	388	410	427	361	388	410	427	399	429	453	472	
LO PR	107	114	124	133	113	120	131	140	118	125	137	146	124	131	144	153	153	130	138	150	160	134	143	156	166	124	131	144	153	130	138	150	160	130	138	150	160	134	143	156	166	
MBh	30.9	31.8	34.4	37.0	30.2	31.1	33.6	36.1	29.5	30.3	32.8	35.2	28.7	29.6	32.0	34.4	34.4	27.3	28.1	30.4	32.7	25.3	26.0	28.2	30.3																	

IDB		OUTDOOR AMBIENT TEMPERATURE																							
		65°F				75°F				85°F				95°F				105°F				115°F			
		ENTERING INDOOR WET BULB TEMPERATURE																							
AIRFLOW	59	63	67	71	59	63	67	71	59	63	67	71	59	63	67	71	59	63	67	71	59	63	67	71	
1350	MBh	35.1	35.9	38.3	41.0	34.3	35.0	37.4	40.0	33.5	34.2	36.5	39.0	32.6	33.4	35.6	38.1	31.0	31.7	33.9	36.2	28.7	29.4	31.4	33.5
	S/T	0.90	0.85	0.69	0.51	0.93	0.88	0.71	0.53	0.96	0.90	0.73	0.55	1.00	0.93	0.75	0.56	1.00	0.96	0.78	0.59	1.00	0.97	0.79	0.59
	ΔT	22	21	18	14	22	21	18	15	22	21	18	15	22	21	18	15	21	21	18	14	21	19	17	13
	kW	2.47	2.52	2.60	2.67	2.65	2.70	2.78	2.87	2.80	2.86	2.95	3.04	2.94	3.00	3.09	3.19	3.06	3.12	3.22	3.32	3.16	3.22	3.33	3.43
	Amps	8.6	8.8	9.0	9.2	9.1	9.3	9.5	9.8	9.7	9.9	10.1	10.4	10.2	10.4	10.7	11.0	10.7	10.9	11.2	11.6	11.2	11.4	11.7	12.1
1200	HI PR	225	242	256	267	253	272	287	299	287	309	326	340	327	352	372	388	368	396	418	436	407	438	462	482
	LO PR	109	116	127	135	116	123	134	143	120	128	139	148	126	134	146	156	132	141	153	163	137	145	159	169
	MBh	34.1	34.8	37.2	39.8	33.3	34.0	36.3	38.8	32.5	33.2	35.5	37.9	31.7	32.4	34.6	37.0	30.1	30.8	32.9	35.1	27.9	28.5	30.4	32.5
	S/T	0.86	0.81	0.66	0.49	0.89	0.84	0.68	0.51	0.91	0.86	0.70	0.52	0.94	0.88	0.72	0.54	0.98	0.92	0.75	0.56	0.99	0.93	0.75	0.56
	ΔT	22	22	19	15	23	22	19	15	23	22	19	15	23	22	19	15	23	22	19	15	21	20	18	14
1050	kW	2.46	2.50	2.58	2.65	2.63	2.68	2.76	2.85	2.78	2.84	2.93	3.02	2.92	2.98	3.07	3.17	3.03	3.10	3.19	3.29	3.13	3.20	3.30	3.40
	Amps	8.6	8.7	8.9	9.2	9.1	9.2	9.5	9.7	9.6	9.8	10.1	10.4	10.1	10.3	10.6	10.9	10.6	10.8	11.1	11.5	11.1	11.4	11.7	12.0
	HI PR	223	240	253	264	250	269	284	296	284	306	323	337	324	348	368	384	364	392	414	432	403	433	457	477
	LO PR	108	115	126	134	114	122	133	141	119	126	138	147	125	133	145	154	131	139	152	162	135	144	157	167
	MBh	31.4	32.1	34.3	36.7	30.7	31.4	33.5	35.8	30.0	30.6	32.7	35.0	29.3	29.9	31.9	34.1	27.8	28.4	30.3	32.4	25.7	26.3	28.1	30.0
80	S/T	0.83	0.78	0.63	0.47	0.86	0.81	0.66	0.49	0.88	0.83	0.67	0.50	0.91	0.85	0.69	0.52	0.94	0.89	0.72	0.54	0.95	0.89	0.73	0.54
	ΔT	23	22	19	15	23	22	19	15	23	22	19	15	23	22	19	16	23	22	19	15	21	21	18	14
	kW	2.40	2.45	2.52	2.59	2.57	2.62	2.70	2.78	2.72	2.77	2.86	2.95	2.85	2.91	3.00	3.09	2.96	3.02	3.12	3.22	3.06	3.12	3.22	3.32
	Amps	8.4	8.5	8.7	9.0	8.9	9.0	9.3	9.5	9.4	9.6	9.9	10.1	9.9	10.1	10.4	10.7	10.4	10.6	10.9	11.2	10.9	11.1	11.4	11.7
	HI PR	216	233	246	256	243	261	276	287	276	297	313	327	314	338	357	372	353	380	402	419	390	420	444	463
LO PR	105	112	122	130	111	118	129	137	115	123	134	143	121	129	141	150	127	135	147	157	131	140	152	162	

1350	MBh	35.7	36.4	38.1	40.7	34.9	35.6	37.2	39.7	34.0	34.7	36.3	38.8	33.2	33.9	35.5	37.8	31.6	32.2	33.7	35.9	29.2	29.8	31.2	33.3
	S/T	0.95	0.91	0.82	0.67	0.98	0.95	0.85	0.69	1.00	0.97	0.87	0.71	1.00	1.00	0.90	0.73	1.00	1.00	0.94	0.76	1.00	1.00	0.94	0.77
	ΔT	23	23	21	18	23	23	22	19	23	23	22	19	23	23	22	19	21	22	21	19	20	20	20	17
	kW	2.49	2.54	2.61	2.69	2.67	2.72	2.80	2.89	2.83	2.88	2.97	3.06	2.96	3.03	3.12	3.22	3.08	3.15	3.24	3.35	3.18	3.25	3.35	3.46
	Amps	8.7	8.8	9.0	9.3	9.2	9.4	9.6	9.9	9.8	10.0	10.2	10.5	10.3	10.5	10.8	11.1	10.8	11.0	11.3	11.6	11.3	11.5	11.8	12.2
1200	HI PR	227	245	258	269	255	274	290	302	290	312	330	344	330	356	375	392	372	400	422	440	411	442	467	487
	LO PR	110	117	128	137	117	124	135	144	121	129	141	150	127	135	148	158	133	142	155	165	138	147	160	171
	MBh	34.7	35.3	37.0	39.5	33.9	34.5	36.1	38.6	33.1	33.7	35.3	37.6	32.2	32.9	34.4	36.7	30.6	31.2	32.7	34.9	28.4	28.9	30.3	32.3
	S/T	0.90	0.87	0.79	0.64	0.93	0.90	0.81	0.66	0.96	0.92	0.83	0.68	0.99	0.95	0.86	0.70	1.00	0.99	0.89	0.73	1.00	1.00	0.90	0.73
	ΔT	24	24	22	19	24	24	23	20	24	24	23	20	24	24	23	20	23	24	22	19	22	22	21	18
1050	kW	2.47	2.52	2.60	2.67	2.65	2.70	2.78	2.87	2.80	2.86	2.95	3.04	2.94	3.00	3.09	3.19	3.06	3.12	3.22	3.32	3.16	3.22	3.33	3.43
	Amps	8.6	8.8	9.0	9.2	9.1	9.3	9.5	9.8	9.7	9.9	10.1	10.4	10.2	10.4	10.7	11.0	10.7	10.9	11.2	11.6	11.2	11.4	11.7	12.1
	HI PR	225	242	256	267	253	272	287	299	287	309	326	340	327	352	372	388	368	396	418	436	407	438	462	482
	LO PR	109	116	127	135	116	123	134	143	120	128	139	148	126	134	146	156	132	141	153	163	137	145	159	169
	MBh	32.0	32.6	34.2	36.4	31.3	31.9	33.4	35.6	30.5	31.1	32.6	34.7	29.8	30.3	31.8	33.9	28.3	28.8	30.2	32.2	26.2	26.7	28.0	29.8
85	S/T	0.87	0.84	0.76	0.61	0.90	0.87	0.78	0.64	0.92	0.89	0.80	0.65	0.95	0.92	0.83	0.67	0.99	0.95	0.86	0.70	1.00	0.96	0.87	0.71
	ΔT	24	24	23	20	25	24	23	20	25	24	23	20	25	24	23	20	25	24	23	20	23	23	21	18
	kW	2.42	2.47	2.54	2.61	2.59	2.64	2.72	2.80	2.74	2.80	2.88	2.97	2.87	2.93	3.02	3.12	2.99	3.05	3.14	3.24	3.08	3.15	3.25	3.35
	Amps	8.5	8.6	8.8	9.0	8.9	9.1	9.3	9.6	9.5	9.7	9.9	10.2	10.0	10.2	10.4	10.8	10.5	10.7	11.0	11.3	11.0	11.2	11.5	11.8
	HI PR	218	235	248	259	245	264	278	290	279	300	317	330	317	341	361	376	357	384	406	423	394	424	448	467
LO PR	106	113	123	131	112	119	130	139	116	124	135	144	122	130	142	151	128	136	149	159	133	141	154	164	

IDB = Entering Indoor Dry Bulb Temperature
 High and low pressures are measured at the liquid and suction service ports.
 Shaded area reflects AHRI Ratings conditions
 Amps: Unit amps (comp.+ evaporator + condenser fan motors)
 kW = Total system power

IDB		OUTDOOR AMBIENT TEMPERATURE																							
		65°F				75°F				85°F				95°F				105°F				115°F			
		ENTERING INDOOR WET BULB TEMPERATURE																							
		59	63	67	71	59	63	67	71	59	63	67	71	59	63	67	71	59	63	67	71	59	63	67	71
1800	MBh	44.6	46.2	50.6	-	43.5	45.1	49.5	-	42.5	44.1	48.3	-	41.5	43.0	47.1	-	39.4	40.8	44.7	-	36.5	37.8	41.4	-
	S/T	0.74	0.62	0.43	-	0.77	0.64	0.44	-	0.79	0.66	0.45	-	0.81	0.68	0.47	-	0.84	0.70	0.49	-	0.85	0.71	0.49	-
	ΔT	17	15	11	-	17	15	11	-	17	15	11	-	17	15	11	-	17	15	11	-	16	14	10	-
	kW	3.13	3.19	3.29	-	3.36	3.43	3.53	-	3.56	3.63	3.75	-	3.74	3.82	3.94	-	3.89	3.97	4.10	-	4.02	4.10	4.23	-
	Amps	10.2	10.4	10.6	-	10.8	11.0	11.3	-	11.5	11.7	12.0	-	12.1	12.3	12.6	-	12.7	12.9	13.3	-	13.3	13.5	13.9	-
1600	HI PR	239	257	271	-	268	288	304	-	305	328	346	-	347	373	394	-	390	420	444	-	431	464	490	-
	LO PR	110	117	128	-	116	124	135	-	121	129	141	-	127	135	148	-	133	142	155	-	138	147	160	-
	MBh	43.3	44.9	49.2	-	42.3	43.8	48.0	-	41.3	42.8	46.9	-	40.3	41.7	45.7	-	38.3	39.6	43.4	-	35.4	36.7	40.2	-
	S/T	0.70	0.59	0.41	-	0.73	0.61	0.42	-	0.75	0.63	0.43	-	0.77	0.65	0.45	-	0.80	0.67	0.46	-	0.81	0.68	0.47	-
	ΔT	18	15	12	-	18	15	12	-	18	15	12	-	18	15	12	-	18	15	12	-	16	14	11	-
1400	kW	3.11	3.17	3.27	-	3.33	3.40	3.51	-	3.53	3.61	3.72	-	3.71	3.79	3.90	-	3.86	3.94	4.06	-	3.99	4.07	4.20	-
	Amps	10.1	10.3	10.6	-	10.7	10.9	11.2	-	11.4	11.6	11.9	-	12.0	12.2	12.5	-	12.6	12.8	13.2	-	13.2	13.4	13.8	-
	HI PR	236	254	269	-	265	285	301	-	302	325	343	-	344	370	390	-	386	416	439	-	427	460	485	-
	LO PR	109	116	127	-	115	123	134	-	120	128	139	-	126	134	146	-	132	140	153	-	136	145	158	-
	MBh	40.0	41.4	45.4	-	39.0	40.4	44.3	-	38.1	39.5	43.3	-	37.2	38.5	42.2	-	35.3	36.6	40.1	-	32.7	33.9	37.1	-
70	S/T	0.68	0.57	0.39	-	0.70	0.59	0.41	-	0.72	0.60	0.42	-	0.75	0.62	0.43	-	0.77	0.65	0.45	-	0.78	0.65	0.45	-
	ΔT	18	15	12	-	18	16	12	-	18	16	12	-	18	16	12	-	18	16	12	-	17	15	11	-
	kW	3.04	3.10	3.19	-	3.26	3.32	3.42	-	3.45	3.52	3.63	-	3.62	3.70	3.81	-	3.76	3.84	3.97	-	3.89	3.97	4.10	-
	Amps	9.9	10.1	10.3	-	10.5	10.7	11.0	-	11.2	11.4	11.7	-	11.7	12.0	12.3	-	12.3	12.6	12.9	-	12.9	13.1	13.5	-
	HI PR	229	247	261	-	257	277	292	-	293	315	332	-	333	359	379	-	375	403	426	-	414	446	471	-
LO PR	106	113	123	-	112	119	130	-	116	124	135	-	122	130	142	-	128	136	149	-	132	141	154	-	
1800	MBh	45.3	46.7	50.5	54.2	44.3	45.6	49.4	53.0	43.2	44.5	48.2	51.7	42.2	43.4	47.0	50.4	40.1	41.3	44.7	47.9	37.1	38.2	41.4	44.4
	S/T	0.84	0.75	0.57	0.37	0.87	0.78	0.59	0.38	0.89	0.80	0.60	0.39	0.92	0.82	0.62	0.40	0.96	0.86	0.65	0.42	0.96	0.86	0.65	0.42
	ΔT	19	18	15	10	20	18	15	10	20	18	15	10	20	18	15	10	20	18	15	10	18	17	14	10
	kW	3.16	3.22	3.32	3.42	3.39	3.46	3.56	3.67	3.59	3.66	3.78	3.90	3.77	3.85	3.97	4.09	3.92	4.00	4.13	4.26	4.05	4.14	4.27	4.41
	Amps	10.3	10.4	10.7	11.0	10.9	11.1	11.3	11.7	11.6	11.8	12.1	12.4	12.2	12.4	12.7	13.1	12.8	13.0	13.4	13.8	13.4	13.6	14.0	14.4
1600	HI PR	241	260	274	286	271	291	307	321	308	331	350	365	351	377	398	415	394	424	448	467	436	469	495	516
	LO PR	111	118	129	138	118	125	137	146	122	130	142	151	128	137	149	159	135	143	156	167	139	148	162	172
	MBh	44.0	45.3	49.1	52.7	43.0	44.3	47.9	51.4	42.0	43.2	46.8	50.2	41.0	42.2	45.6	49.0	38.9	40.1	43.4	46.5	36.0	37.1	40.2	43.1
	S/T	0.80	0.72	0.54	0.35	0.83	0.74	0.56	0.36	0.85	0.76	0.58	0.37	0.88	0.79	0.59	0.38	0.91	0.82	0.62	0.40	0.92	0.82	0.62	0.40
	ΔT	20	19	15	11	21	19	15	11	21	19	15	11	21	19	16	11	20	19	15	11	19	18	14	10
1400	kW	3.13	3.20	3.29	3.39	3.36	3.43	3.53	3.64	3.56	3.63	3.75	3.87	3.74	3.82	3.94	4.06	3.89	3.97	4.10	4.23	4.02	4.10	4.24	4.37
	Amps	10.2	10.4	10.6	10.9	10.8	11.0	11.3	11.6	11.5	11.7	12.0	12.3	12.1	12.3	12.6	13.0	12.7	12.9	13.3	13.7	13.3	13.5	13.9	14.3
	HI PR	239	257	271	283	268	288	304	318	305	328	346	361	347	373	394	411	390	420	444	463	431	464	490	511
	LO PR	110	117	128	136	116	124	135	144	121	129	141	150	127	135	148	157	133	142	155	165	138	147	160	171
	MBh	40.6	41.8	45.3	48.6	39.7	40.9	44.2	47.5	38.7	39.9	43.2	46.3	37.8	38.9	42.1	45.2	35.9	37.0	40.0	42.9	33.3	34.2	37.1	39.8
75	S/T	0.77	0.69	0.52	0.34	0.80	0.72	0.54	0.35	0.82	0.73	0.56	0.36	0.85	0.76	0.57	0.37	0.88	0.79	0.60	0.38	0.89	0.79	0.60	0.39
	ΔT	21	19	16	11	21	19	16	11	21	19	16	11	21	19	16	11	21	19	16	11	19	18	15	10
	kW	3.06	3.12	3.22	3.31	3.28	3.35	3.45	3.56	3.48	3.55	3.66	3.77	3.65	3.73	3.84	3.96	3.80	3.88	4.00	4.13	3.92	4.00	4.13	4.27
	Amps	10.0	10.2	10.4	10.7	10.6	10.8	11.0	11.3	11.3	11.5	11.7	12.1	11.8	12.1	12.4	12.7	12.4	12.6	13.0	13.4	13.0	13.2	13.6	14.0
	HI PR	232	249	263	275	260	280	295	308	296	318	336	350	337	362	383	399	379	408	430	449	418	450	475	496
LO PR	107	114	124	132	113	120	131	140	117	125	136	145	123	131	143	153	129	138	150	160	134	142	155	165	

IDB = Entering Indoor Dry Bulb Temperature
 High and low pressures are measured at the liquid and suction service ports.
 Shaded area reflects ACCA (TVA) conditions
 Amps: Unit amps (comp.+ evaporator + condenser fan motors)
 kW = Total system power

IDB		OUTDOOR AMBIENT TEMPERATURE												105°F												115°F											
		65°F						75°F						85°F						95°F						105°F						115°F					
		ENTERING INDOOR WET BULB TEMPERATURE												105°F												115°F											
AIRFLOW		59	63	67	71	59	63	67	71	59	63	67	71	59	63	67	71	59	63	67	71	59	63	67	71	59	63	67	71								
80	MBh	46.1	47.2	50.4	53.9	45.1	46.1	49.2	52.6	44.0	45.0	48.0	51.4	42.9	43.9	46.9	50.1	40.8	41.7	44.5	47.6	37.8	38.6	41.2	44.1	40.8	41.7	44.5	47.6	37.8	38.6	41.2	44.1	38.4	39.2	41.0	43.8
	S/T	0.92	0.86	0.70	0.53	0.95	0.90	0.73	0.54	1.00	0.92	0.75	0.56	1.00	0.95	0.77	0.58	1.00	1.00	0.80	0.60	1.00	1.00	0.81	0.60	1.00	1.00	0.80	0.60	1.00	1.00	0.81	0.60	1.00	1.00	0.92	0.78
	ΔT	22	21	18	14	22	21	18	15	22	21	18	15	22	21	18	15	22	21	18	15	19	20	17	14	21	21	18	15	19	20	17	14	20	20	20	18
	kW	3.18	3.24	3.34	3.44	3.41	3.48	3.59	3.70	3.62	3.69	3.81	3.93	3.80	3.88	4.00	4.13	3.95	4.04	4.16	4.30	4.08	4.17	4.31	4.45	3.95	4.04	4.16	4.30	4.08	4.17	4.31	4.45	4.08	4.17	4.31	4.45
	Amps	10.3	10.5	10.8	11.1	10.9	11.1	11.4	11.7	11.7	11.9	12.2	12.5	12.3	12.5	12.8	13.2	12.9	13.1	13.5	13.9	13.5	13.7	14.1	14.5	12.9	13.1	13.5	13.9	13.5	13.7	14.1	14.5	13.5	13.7	14.1	14.5
	HI PR	244	262	277	289	273	294	311	324	311	335	353	368	354	381	402	420	398	429	453	472	440	474	500	522	398	429	453	472	440	474	500	522	440	474	500	522
	LO PR	112	120	131	139	119	126	138	147	124	131	143	153	130	138	151	160	136	145	158	168	141	150	163	174	136	145	158	168	141	150	163	174	141	150	163	174
	MBh	44.8	45.8	48.9	52.3	43.8	44.7	47.8	51.1	42.7	43.7	46.6	49.9	41.7	42.6	45.5	48.6	39.6	40.5	43.2	46.2	36.7	37.5	40.0	42.8	39.6	40.5	43.2	46.2	36.7	37.5	40.0	42.8	36.7	37.5	40.0	42.8
	S/T	0.88	0.82	0.67	0.50	0.91	0.85	0.70	0.52	0.93	0.88	0.71	0.53	0.96	0.90	0.74	0.55	1.00	0.94	0.76	0.57	1.00	0.95	0.77	0.58	1.00	0.94	0.76	0.57	1.00	0.95	0.77	0.58	0.95	0.91	0.74	0.55
	ΔT	23	22	19	15	23	22	19	15	23	22	19	15	23	22	19	15	23	22	19	15	21	20	18	14	23	22	19	15	21	20	18	14	21	20	18	14
kW	3.16	3.22	3.32	3.42	3.39	3.46	3.56	3.67	3.59	3.66	3.78	3.90	3.77	3.85	3.97	4.10	3.92	4.00	4.13	4.26	4.05	4.14	4.27	4.41	3.92	4.00	4.13	4.26	4.05	4.14	4.27	4.41	4.05	4.14	4.27	4.41	
Amps	10.3	10.4	10.7	11.0	10.9	11.1	11.3	11.7	11.6	11.8	12.1	12.4	12.2	12.4	12.7	13.1	12.8	13.0	13.4	13.8	13.4	13.6	14.0	14.4	12.8	13.0	13.4	13.8	13.4	13.6	14.0	14.4	13.4	13.6	14.0	14.4	
HI PR	241	260	274	286	271	291	308	321	308	331	350	365	351	377	398	415	394	424	448	467	436	469	495	516	394	424	448	467	436	469	495	516	424	448	469	495	
LO PR	111	118	129	138	118	125	137	146	122	130	142	151	128	137	149	159	135	143	156	167	139	148	162	172	135	143	156	167	139	148	162	172	139	148	162	172	
MBh	41.4	42.3	45.1	48.3	40.4	41.3	44.1	47.1	39.4	40.3	43.0	46.0	38.5	39.3	42.0	44.9	36.5	37.3	39.9	42.6	33.9	34.6	37.0	39.5	36.5	37.3	39.9	42.6	33.9	34.6	37.0	39.5	34.6	35.4	37.0	39.5	
S/T	0.85	0.79	0.65	0.48	0.88	0.82	0.67	0.50	0.90	0.84	0.69	0.51	0.93	0.87	0.71	0.53	0.96	0.90	0.74	0.55	0.97	0.91	0.74	0.55	0.96	0.90	0.74	0.55	0.97	0.91	0.74	0.55	0.91	0.87	0.74	0.55	
ΔT	23	22	19	15	23	22	19	16	23	22	19	16	23	22	19	16	23	22	19	15	22	21	18	14	23	22	19	15	22	21	18	14	22	21	18	14	
kW	3.09	3.15	3.24	3.34	3.31	3.38	3.48	3.59	3.50	3.58	3.69	3.80	3.68	3.76	3.87	4.00	3.83	3.91	4.03	4.16	3.95	4.04	4.17	4.30	3.83	3.91	4.03	4.16	3.95	4.04	4.17	4.30	4.04	4.13	4.26	4.40	
Amps	10.1	10.2	10.5	10.8	10.7	10.8	11.1	11.4	11.3	11.5	11.8	12.2	11.9	12.1	12.4	12.8	12.5	12.7	13.1	13.5	13.1	13.3	13.7	14.1	12.5	12.7	13.1	13.5	13.1	13.3	13.7	14.1	13.3	13.7	14.1	14.5	
HI PR	234	252	266	277	263	282	298	311	299	321	339	354	340	366	386	403	383	412	435	453	423	455	480	501	383	412	435	453	423	455	480	501	423	455	480	501	
LO PR	108	115	125	134	114	121	133	141	119	126	138	147	125	133	145	154	131	139	152	162	135	144	157	167	131	139	152	162	135	144	157	167	135	144	157	167	
85	MBh	47.0	47.9	50.1	53.5	45.9	46.7	49.0	52.2	44.8	45.6	47.8	51.0	43.7	44.5	46.6	49.7	41.5	42.3	44.3	47.3	38.4	39.2	41.0	43.8	41.5	42.3	44.3	47.3	38.4	39.2	41.0	43.8	39.2	40.0	41.6	44.4
	S/T	0.97	0.93	0.84	0.68	1.00	0.97	0.87	0.71	1.00	0.99	0.89	0.73	1.00	1.00	0.92	0.75	1.00	1.00	0.96	0.78	1.00	1.00	0.97	0.78	1.00	1.00	0.96	0.78	1.00	1.00	0.97	0.78	0.97	0.93	0.78	0.63
	ΔT	23	23	22	19	23	23	22	19	23	23	22	19	23	23	22	19	23	23	22	19	21	20	18	14	21	22	22	19	21	20	18	14	20	20	20	18
	kW	3.20	3.27	3.37	3.47	3.44	3.51	3.62	3.73	3.65	3.72	3.84	3.96	3.83	3.91	4.03	4.16	3.98	4.07	4.20	4.33	4.12	4.21	4.34	4.48	3.98	4.07	4.20	4.33	4.12	4.21	4.34	4.48	4.21	4.30	4.43	4.57
	Amps	10.4	10.6	10.8	11.1	11.0	11.2	11.5	11.8	11.7	11.9	12.3	12.6	12.3	12.6	12.9	13.3	13.0	13.2	13.6	14.0	13.6	13.8	14.2	14.6	12.9	13.1	13.5	13.9	13.6	13.8	14.2	14.6	13.8	14.2	14.6	15.0
	HI PR	246	265	280	292	276	297	314	327	314	338	357	372	358	385	406	424	402	433	457	477	444	478	505	527	402	433	457	477	444	478	505	527	477	499	513	527
	LO PR	114	121	132	141	120	128	139	148	125	133	145	154	131	139	152	162	137	146	160	170	142	151	165	176	137	146	160	170	142	151	165	176	142	151	165	176
	MBh	45.6	46.5	48.7	51.9	44.5	45.4	47.5	50.7	43.5	44.3	46.4	49.5	42.4	43.2	45.3	48.3	40.3	41.1	43.0	45.9	37.3	38.0	39.8	42.5	40.3	41.1	43.0	45.9	37.3	38.0	39.8	42.5	38.0	38.8	40.4	43.2
	S/T	0.92	0.89	0.80	0.65	0.95	0.92	0.83	0.67	0.98	0.94	0.85	0.69	1.00	0.97	0.88	0.71	1.00	1.00	0.91	0.74	1.00	1.00	0.92	0.75	1.00	1.00	0.91	0.74	1.00	1.00	0.92	0.75	0.92	0.89	0.74	0.59
	ΔT	24	24	22	19	24	24	23	20	24	24	23	20	24	24	23	20	24	24	23	20	21	22	21	18	23	24	23	20	21	22	21	18	22	22	21	18
kW	3.18	3.24	3.34	3.44	3.41	3.48	3.59	3.70	3.62	3.69	3.81	3.93	3.80	3.88	4.00	4.13	3.95	4.04	4.16	4.30	4.08	4.17	4.31	4.45	3.95	4.04	4.16	4.30	4.08	4.17	4.31	4.45	4.17	4.26	4.39	4.53	
Amps	10.3	10.5	10.8	11.1	10.9	11.1	11.4	11.7	11.7	11.9	12.2	12.5	12.3	12.5	12.8	13.2	12.9	13.1	13.5	13.9	13.5	13.7	14.1	14.5	12.9	13.1	13.5	13.9	13.5	13.7	14.1	14.5	13.7	14.1	14.5	15.0	
HI PR	244	262	277	289	273	294	311	324	311	335	353	368	354	381	402	420	398	429	453	472	440	474	500	522	398	429	453	472	440	474	500	522	474	496	509	522	
LO PR	112	120	131	139	119	126	138	147	124	131	143	153	130	138	151	160	136	145	158	168	141	150	163	174	136	145	158	168	141	150	163	174	141	150	163	174	
MBh	42.1	42.9	44.9	47.9	41.1	41.9	43.9	46.8	40.1	40.9	42.8	45.7	39.1	39.9	41.8	44.6	37.2	37.9	39.7	42.4	34.4	35.1	36.8	39.2	37.2	37.9	39.7	42.4	34.4	35.1	36.8	39.2	36.8	37.6	39.2	41.8	
S/T	0.89	0.86	0.77	0.63	0.92	0.89	0.80	0.65	0.94	0.91	0.82	0.67	0.97	0.94	0.85	0.69	1.00	0.98	0.88	0.71	1.00	0.98	0.89	0.72	1.00	0.98	0.88	0.71									

IDB		OUTDOOR AMBIENT TEMPERATURE																							
		65°F				75°F				85°F				95°F				105°F				115°F			
		ENTERING INDOOR WET BULB TEMPERATURE																							
AIRFLOW		59	63	67	71	59	63	67	71	59	63	67	71	59	63	67	71	59	63	67	71	59	63	67	71
2250	MBh	56.8	58.9	64.5	-	55.5	57.5	63.0	-	54.2	56.2	61.5	-	52.9	54.8	60.0	-	50.2	52.1	57.0	-	46.5	48.2	52.8	-
	S/T	0.74	0.62	0.43	-	0.77	0.64	0.44	-	0.79	0.66	0.46	-	0.81	0.68	0.47	-	0.84	0.70	0.49	-	0.85	0.71	0.49	-
	ΔT	17	15	11	-	17	15	11	-	17	15	11	-	18	15	12	-	17	15	11	-	16	14	11	-
	kW	4.10	4.19	4.32	-	4.41	4.50	4.64	-	4.68	4.78	4.93	-	4.92	5.02	5.18	-	5.12	5.23	5.40	-	5.29	5.41	5.58	-
	HI PR	244	262	277	-	273	294	311	-	311	335	353	-	354	381	402	-	398	429	453	-	440	474	500	-
LO PR	107	114	125	-	113	121	132	-	118	125	137	-	124	132	144	-	130	138	151	-	134	143	156	-	
2000	MBh	55.2	57.2	62.7	-	53.9	55.9	61.2	-	52.6	54.5	59.7	-	51.3	53.2	58.3	-	48.8	50.5	55.4	-	45.2	46.8	51.3	-
	S/T	0.71	0.59	0.41	-	0.73	0.61	0.42	-	0.75	0.63	0.43	-	0.77	0.65	0.45	-	0.80	0.67	0.47	-	0.81	0.68	0.47	-
	ΔT	18	16	12	-	18	16	12	-	18	16	12	-	18	16	12	-	18	16	12	-	17	15	11	-
	kW	4.07	4.16	4.28	-	4.37	4.47	4.60	-	4.64	4.74	4.89	-	4.88	4.98	5.14	-	5.08	5.19	5.35	-	5.25	5.36	5.54	-
	HI PR	241	260	274	-	271	291	308	-	308	331	350	-	351	377	398	-	394	424	448	-	436	469	495	-
LO PR	106	113	123	-	112	119	130	-	117	124	136	-	123	130	142	-	128	137	149	-	133	141	154	-	
1750	MBh	50.9	52.8	57.8	-	49.7	51.6	56.5	-	48.6	50.3	55.1	-	47.4	49.1	53.8	-	45.0	46.7	51.1	-	41.7	43.2	47.3	-
	S/T	0.68	0.57	0.39	-	0.71	0.59	0.41	-	0.72	0.60	0.42	-	0.75	0.62	0.43	-	0.78	0.65	0.45	-	0.78	0.65	0.45	-
	ΔT	18	16	12	-	18	16	12	-	18	16	12	-	19	16	12	-	18	16	12	-	17	15	11	-
	kW	3.98	4.06	4.18	-	4.27	4.36	4.50	-	4.53	4.63	4.77	-	4.76	4.86	5.01	-	4.95	5.06	5.22	-	5.12	5.23	5.40	-
	HI PR	234	252	266	-	263	283	298	-	299	321	339	-	340	366	386	-	383	412	435	-	423	455	480	-
LO PR	103	110	120	-	109	116	127	-	113	120	131	-	119	127	138	-	125	133	145	-	129	137	150	-	
2250	MBh	57.8	59.5	64.4	69.1	56.5	58.1	62.9	67.5	55.1	56.7	61.4	65.9	53.8	55.4	59.9	64.3	51.1	52.6	56.9	61.1	47.3	48.7	52.7	56.6
	S/T	0.84	0.75	0.57	0.37	0.87	0.78	0.59	0.38	0.89	0.80	0.61	0.39	0.92	0.83	0.63	0.40	0.96	0.86	0.65	0.42	0.97	0.86	0.65	0.42
	ΔT	20	18	15	10	20	19	15	10	20	19	15	10	20	19	15	11	20	18	15	10	19	17	14	10
	kW	4.14	4.22	4.35	4.49	4.44	4.54	4.68	4.83	4.72	4.82	4.97	5.13	4.96	5.06	5.22	5.40	5.16	5.27	5.44	5.62	5.34	5.45	5.63	5.82
	HI PR	246	265	280	292	276	297	314	327	314	338	357	372	358	385	407	424	402	433	457	477	445	479	505	527
LO PR	108	115	126	134	115	122	133	142	119	127	138	147	125	133	145	155	131	139	152	162	136	144	157	168	
2000	MBh	56.1	57.8	62.5	67.1	54.8	56.4	61.1	65.6	53.5	55.1	59.6	64.0	52.2	53.7	58.2	62.4	49.6	51.1	55.3	59.3	45.9	47.3	51.2	54.9
	S/T	0.80	0.72	0.54	0.35	0.83	0.74	0.56	0.36	0.85	0.76	0.58	0.37	0.88	0.79	0.60	0.38	0.91	0.82	0.62	0.40	0.92	0.82	0.62	0.40
	ΔT	21	19	16	11	21	19	16	11	21	19	16	11	21	19	16	11	21	19	16	11	19	18	15	10
	kW	4.11	4.19	4.32	4.45	4.41	4.50	4.64	4.79	4.68	4.78	4.93	5.09	4.92	5.02	5.18	5.35	5.12	5.23	5.40	5.58	5.29	5.41	5.58	5.77
	HI PR	244	262	277	289	273	294	311	324	311	335	353	369	354	381	402	420	398	429	453	472	440	474	500	522
LO PR	107	114	125	133	113	121	132	140	118	125	137	146	124	132	144	153	130	138	151	161	134	143	156	166	
1750	MBh	51.8	53.3	57.7	62.0	50.6	52.1	56.4	60.5	49.4	50.8	55.0	59.1	48.2	49.6	53.7	57.6	45.8	47.1	51.0	54.7	42.4	43.7	47.3	50.7
	S/T	0.77	0.69	0.52	0.34	0.80	0.72	0.54	0.35	0.82	0.74	0.56	0.36	0.85	0.76	0.57	0.37	0.88	0.79	0.60	0.38	0.89	0.79	0.60	0.39
	ΔT	21	19	16	11	21	20	16	11	21	20	16	11	21	20	16	11	21	20	16	11	20	18	15	10
	kW	4.01	4.09	4.22	4.35	4.31	4.40	4.53	4.67	4.57	4.66	4.81	4.96	4.80	4.90	5.06	5.22	4.99	5.10	5.26	5.44	5.16	5.27	5.44	5.62
	HI PR	236	254	269	280	265	285	301	314	302	325	343	358	344	370	390	407	387	416	439	458	427	460	485	506
LO PR	104	111	121	129	110	117	128	136	114	122	133	141	120	128	140	149	126	134	146	156	130	139	151	161	

IDB = Entering Indoor Dry Bulb Temperature
 High and low pressures are measured at the liquid and suction service ports.
 Shaded area reflects ACCA (TVA) conditions
 kW = Total system power
 Amps: Unit amps (comp.+ evaporator + condenser fan motors)

IDB		OUTDOOR AMBIENT TEMPERATURE																							
		75°F				85°F				95°F				105°F				115°F							
		59	63	67	71	59	63	67	71	59	63	67	71	59	63	67	71	59	63	67	71				
2250		AIRFLOW	59	63	67	71	59	63	67	71	59	63	67	71	59	63	67	71	59	63	67	71			
	MBh	58.8	60.1	64.2	68.7	57.5	58.7	62.7	67.1	56.1	57.3	61.2	65.5	54.7	55.9	59.7	63.9	52.0	53.1	56.8	60.7	48.2	49.2	52.6	56.2
	S/T	0.92	0.87	0.70	0.5	0.96	0.90	0.73	0.5	1.00	0.92	0.75	0.6	1.00	0.95	0.77	0.6	1.00	1.00	0.80	0.6	1.00	1.00	0.81	0.6
	ΔT	22	21	18	15	22	22	19	15	23	22	19	15	22	22	19	15	21	22	19	15	20	20	17	13.9
	kW	4.17	4.25	4.38	4.5	4.48	4.57	4.72	4.9	4.75	4.86	5.01	5.2	5.00	5.10	5.27	5.4	5.20	5.32	5.49	5.7	5.38	5.50	5.68	5.9
	HI PR	249	268	283	294.7	279	300	317	330.6	317	341	361	376.0	361	389	411	428.3	407	437	462	481.8	449	483	510	532.3
	LO PR	110	117	127	135.5	116	123	134	143.2	120	128	140	148.8	126	134	147	156.3	132	141	154	163.8	137	146	159	169.4
80	MBh	57.1	58.4	62.4	66.7	55.8	57.0	60.9	65.1	54.5	55.6	59.5	63.6	53.1	54.3	58.0	62.0	50.5	51.6	55.1	58.9	46.8	47.8	51.0	54.6
	S/T	0.88	0.83	0.67	0.5	0.91	0.86	0.70	0.5	0.94	0.88	0.71	0.5	0.97	0.91	0.74	0.6	1.00	0.94	0.77	0.6	1.00	0.95	0.77	0.6
	ΔT	23	22	19	15	23	22	20	16	23	22	20	16	24	23	20	16	23	22	19	15	21	21	18	14.5
	kW	4.14	4.22	4.35	4.5	4.44	4.54	4.68	4.8	4.72	4.82	4.97	5.1	4.96	5.06	5.23	5.4	5.16	5.27	5.44	5.6	5.34	5.45	5.63	5.8
	HI PR	246	265	280	291.7	276	297	314	327.4	314	338	357	372.3	358	385	407	424.0	402	433	457	477.0	445	479	505	527.1
	LO PR	108	115	126	134.2	115	122	133	141.7	119	127	138	147.3	125	133	145	154.7	131	139	152	162.2	136	144	158	167.7
1750	MBh	52.7	53.9	57.5	61.5	51.5	52.6	56.2	60.1	50.3	51.4	54.9	58.7	49.0	50.1	53.5	57.2	46.6	47.6	50.9	54.4	43.2	44.1	47.1	50.4
	S/T	0.85	0.80	0.65	0.5	0.88	0.83	0.67	0.5	0.90	0.85	0.69	0.5	0.93	0.87	0.71	0.5	0.97	0.91	0.74	0.6	0.97	0.91	0.74	0.6
	ΔT	24	23	20	16	24	23	20	16	24	23	20	16	24	23	20	16	24	23	20	16	22	21	18	14.7
	kW	4.04	4.12	4.25	4.4	4.34	4.43	4.57	4.7	4.60	4.70	4.85	5.0	4.84	4.94	5.10	5.3	5.03	5.14	5.31	5.5	5.20	5.32	5.49	5.7
	HI PR	239	257	271	283.0	268	288	304	317.5	305	328	346	361.1	347	373	394	411.3	390	420	444	462.7	431	464	490	511.3
	LO PR	105	112	122	130.1	111	118	129	137.5	116	123	134	142.9	121	129	141	150.1	127	135	148	157.3	132	140	153	162.7

2250	MBh	59.9	61.0	63.9	68.2	58.5	59.6	62.4	66.6	57.1	58.2	60.9	65.0	55.7	56.8	59.4	63.4	52.9	53.9	56.5	60.2	49.0	49.9	52.3	55.8
	S/T	0.97	0.93	0.84	0.7	1.00	0.97	0.87	0.7	1.00	0.99	0.90	0.7	1.00	1.00	0.92	0.8	1.00	1.00	0.96	0.8	1.00	1.00	0.97	0.8
	ΔT	24	23	22	19	24	24	22	19	23	24	22	19	23	23	22	19	22	22	22	19	20	20	21	17.9
	kW	4.20	4.29	4.42	4.6	4.51	4.61	4.75	4.9	4.79	4.89	5.05	5.2	5.04	5.15	5.31	5.5	5.24	5.36	5.53	5.7	5.42	5.54	5.72	5.9
	HI PR	251	270	285	297.6	282	303	320	333.9	320	345	364	379.8	365	393	415	432.6	411	442	467	486.6	454	488	515	537.7
	LO PR	111	118	129	136.9	117	124	136	144.6	121	129	141	150.3	128	136	148	157.9	134	142	155	165.4	138	147	161	171.1
2000	MBh	58.1	59.2	62.0	66.2	56.8	57.9	60.6	64.6	55.4	56.5	59.2	63.1	54.1	55.1	57.7	61.6	51.4	52.3	54.8	58.5	47.6	48.5	50.8	54.2
	S/T	0.92	0.89	0.80	0.7	0.96	0.92	0.83	0.7	0.98	0.95	0.85	0.7	1.00	0.98	0.88	0.7	1.00	1.00	0.92	0.7	1.00	1.00	0.92	0.7
	ΔT	25	24	23	20	25	25	23	20	25	25	23	20	25	25	23	20	24	24	23	20	22	22	22	18.6
	kW	4.17	4.25	4.38	4.5	4.48	4.57	4.72	4.9	4.75	4.86	5.01	5.2	5.00	5.10	5.27	5.4	5.20	5.32	5.49	5.7	5.38	5.50	5.68	5.9
	HI PR	249	268	283	294.7	279	300	317	330.6	317	341	361	376.0	361	389	411	428.3	407	437	462	481.8	449	483	510	532.3
	LO PR	110	117	127	135.5	116	123	134	143.2	120	128	140	148.8	126	134	147	156.3	132	141	154	163.8	137	146	159	169.4
1750	MBh	53.6	54.7	57.3	61.1	52.4	53.4	55.9	59.7	51.1	52.1	54.6	58.2	49.9	50.9	53.3	56.8	47.4	48.3	50.6	54.0	43.9	44.8	46.9	50.0
	S/T	0.89	0.86	0.78	0.6	0.92	0.89	0.80	0.7	0.95	0.91	0.82	0.7	0.98	0.94	0.85	0.7	1.00	0.98	0.88	0.7	1.00	0.99	0.89	0.7
	ΔT	25	25	23	20	25	25	24	20	25	25	24	20	26	25	24	21	25	25	23	20	23	23	22	19.0
	kW	4.07	4.16	4.28	4.4	4.37	4.47	4.60	4.7	4.64	4.74	4.89	5.0	4.88	4.98	5.14	5.3	5.07	5.18	5.35	5.5	5.25	5.36	5.54	5.7
	HI PR	241	260	274	285.8	271	291	307	320.7	308	331	350	364.7	351	377	398	415.4	394	424	448	467.4	436	469	495	516.4
	LO PR	106	113	123	131.4	112	119	130	138.9	117	124	136	144.3	123	130	142	151.6	128	137	149	158.9	133	141	154	164.3

IDB = Entering Indoor Dry Bulb Temperature
 High and low pressures are measured at the liquid and suction service ports.
 Shaded area reflects AHRI Ratings conditions
 Amps: Unit amps (comp.+ evaporator + condenser fan motors)
 kW = Total system power

EXPANDED COOLING DATA — 6 TONS - SINGLE SPEED

IDB		OUTDOOR AMBIENT TEMPERATURE																											
		65°F				75°F				85°F				95°F				105°F				115°F							
		59	63	67	71	59	63	67	71	59	63	67	71	59	63	67	71	59	63	67	71	59	63	67	71				
		ENTERING INDOOR WET BULB TEMPERATURE																											
AIRFLOW		59	63	67	71	59	63	67	71	59	63	67	71	59	63	67	71	59	63	67	71	59	63	67	71	59	63	67	71
70	2650	MBh	69.6	72.1	79.0	-	68.0	70.4	77.2	-	66.3	68.8	75.3	-	64.7	67.1	73.5	-	61.5	63.7	69.8	-	57.0	59.0	64.7	-			
		S/T	0.71	0.60	0.41	-	0.74	0.62	0.43	-	0.76	0.63	0.44	-	0.78	0.65	0.45	-	0.81	0.68	0.47	-	0.82	0.68	0.47	-			
		ΔT	17	15	11	-	17	15	11	-	17	15	11	-	18	15	12	-	17	15	11	-	16	14	11	-			
		kW	5.00	5.10	5.25	-	5.36	5.47	5.64	-	5.68	5.80	5.98	-	5.97	6.10	6.29	-	6.21	6.34	6.54	-	6.42	6.56	6.77	-			
		HI PR	231	248	262	-	259	279	294	-	295	317	335	-	336	361	381	-	377	406	429	-	417	449	474	-			
	LO PR	107	114	124	-	113	120	131	-	117	125	136	-	123	131	143	-	129	138	150	-	134	142	155	-				
70	2350	MBh	67.5	70.0	76.7	-	66.0	68.4	74.9	-	64.4	66.8	73.1	-	62.8	65.1	71.4	-	59.7	61.9	67.8	-	55.3	57.3	62.8	-			
		S/T	0.68	0.57	0.39	-	0.70	0.59	0.41	-	0.72	0.60	0.42	-	0.75	0.62	0.43	-	0.77	0.65	0.45	-	0.78	0.65	0.45	-			
		ΔT	18	16	12	-	18	16	12	-	18	16	12	-	18	16	12	-	18	16	12	-	17	15	11	-			
		kW	4.96	5.06	5.21	-	5.32	5.43	5.60	-	5.64	5.76	5.94	-	5.92	6.05	6.24	-	6.16	6.29	6.49	-	6.37	6.50	6.71	-			
		HI PR	229	246	260	-	256	276	291	-	292	314	331	-	332	357	377	-	374	402	425	-	413	444	469	-			
	LO PR	106	113	123	-	112	119	130	-	116	124	135	-	122	130	142	-	128	136	149	-	132	141	154	-				
70	2050	MBh	62.3	64.6	70.8	-	60.9	63.1	69.2	-	59.4	61.6	67.5	-	58.0	60.1	65.9	-	55.1	57.1	62.6	-	51.0	52.9	58.0	-			
		S/T	0.66	0.55	0.38	-	0.68	0.57	0.39	-	0.70	0.58	0.40	-	0.72	0.60	0.42	-	0.75	0.62	0.43	-	0.75	0.63	0.44	-			
		ΔT	18	16	12	-	19	16	12	-	19	16	12	-	19	16	12	-	18	16	12	-	17	15	11	-			
		kW	4.85	4.95	5.09	-	5.20	5.31	5.47	-	5.51	5.62	5.80	-	5.78	5.90	6.09	-	6.01	6.14	6.33	-	6.21	6.35	6.55	-			
		HI PR	222	239	252	-	249	268	283	-	283	304	321	-	322	347	366	-	363	390	412	-	401	431	455	-			
	LO PR	103	109	119	-	109	115	126	-	113	120	131	-	119	126	138	-	124	132	144	-	128	137	149	-				
75	2650	MBh	70.8	72.8	78.9	84.6	69.1	71.2	77.0	82.7	67.5	69.5	75.2	80.7	65.8	67.8	73.3	78.7	62.5	64.4	69.7	74.8	57.9	59.6	64.5	69.3			
		S/T	0.81	0.73	0.55	0.35	0.84	0.75	0.57	0.37	0.86	0.77	0.58	0.38	0.89	0.80	0.60	0.39	0.92	0.83	0.62	0.40	0.93	0.83	0.63	0.41			
		ΔT	20	18	15	10	20	19	15	10	20	19	15	11	20	19	15	11	20	18	15	10	19	17	14	10			
		kW	5.04	5.14	5.29	5.45	5.41	5.52	5.69	5.86	5.73	5.85	6.03	6.22	6.02	6.14	6.34	6.54	6.26	6.39	6.60	6.81	6.47	6.61	6.82	7.05			
		HI PR	233	251	265	276	262	282	297	310	298	320	338	353	339	365	385	402	381	410	433	452	421	453	479	499			
	LO PR	108	115	126	134	114	121	133	141	119	126	138	147	125	133	145	154	131	139	152	162	135	144	157	167				
75	2350	MBh	68.7	70.7	76.6	82.2	67.1	69.1	74.8	80.3	65.5	67.4	73.0	78.3	63.9	65.8	71.2	76.4	60.7	62.5	67.7	72.6	56.2	57.9	62.7	67.3			
		S/T	0.77	0.69	0.52	0.34	0.80	0.72	0.54	0.35	0.82	0.73	0.56	0.36	0.85	0.76	0.57	0.37	0.88	0.79	0.60	0.38	0.89	0.79	0.60	0.39			
		ΔT	21	19	16	11	21	19	16	11	21	19	16	11	21	20	16	11	21	19	16	11	20	18	15	10			
		kW	5.00	5.10	5.25	5.41	5.36	5.47	5.64	5.82	5.69	5.80	5.98	6.17	5.97	6.10	6.29	6.49	6.21	6.34	6.55	6.76	6.42	6.56	6.77	6.99			
		HI PR	231	248	262	274	259	279	294	307	295	317	335	349	336	361	381	398	378	406	429	447	417	449	474	494			
	LO PR	107	114	124	132	113	120	131	140	118	125	136	145	123	131	143	153	129	138	150	160	134	142	155	165				
75	2050	MBh	63.4	65.3	70.7	75.8	61.9	63.8	69.0	74.1	60.5	62.2	67.4	72.3	59.0	60.7	65.7	70.5	56.0	57.7	62.4	67.0	51.9	53.4	57.8	62.1			
		S/T	0.75	0.67	0.50	0.32	0.77	0.69	0.52	0.34	0.79	0.71	0.54	0.35	0.82	0.73	0.55	0.36	0.85	0.76	0.57	0.37	0.86	0.77	0.58	0.37			
		ΔT	21	20	16	11	21	20	16	11	21	20	16	11	22	20	16	11	21	20	16	11	20	18	15	10			
		kW	4.89	4.98	5.13	5.29	5.24	5.35	5.51	5.68	5.55	5.67	5.84	6.03	5.83	5.95	6.14	6.33	6.06	6.19	6.39	6.59	6.26	6.40	6.60	6.82			
		HI PR	224	241	254	265	251	270	286	298	286	308	325	339	326	350	370	386	366	394	416	434	405	435	460	480			
	LO PR	104	110	121	128	110	117	127	136	114	121	132	141	120	127	139	148	125	133	146	155	130	138	151	161				

kW = Total system power
Amps: Unit amps (comp.+ evaporator + condenser fan motors)

Shaded area reflects ACCA (TVA) conditions

IDB = Entering Indoor Dry Bulb Temperature
High and low pressures are measured at the liquid and suction service ports.

IDB	AIRFLOW	OUTDOOR AMBIENT TEMPERATURE																											
		65°F				75°F				85°F				95°F				105°F				115°F							
		59	63	67	71	59	63	67	71	59	63	67	71	59	63	67	71	59	63	67	71	59	63	67	71				
80	MBh	72.0	73.6	78.6	84.0	70.3	71.9	76.8	82.1	68.7	70.2	75.0	80.1	67.0	68.4	73.1	78.2	63.6	65.0	69.5	74.3	63.6	65.0	69.5	74.3	58.9	60.2	64.4	68.8
	S/T	0.89	0.83	0.68	0.5	0.92	0.86	0.70	0.5	0.94	0.89	0.72	0.5	1.00	0.91	0.74	0.6	1.00	0.95	0.77	0.6	1.00	0.95	0.77	0.6	1.00	0.96	0.78	0.6
	ΔT	22	21	19	15	22	22	19	15	23	22	19	15	23	22	19	15	22	21	19	15	22	21	19	15	20	20	17	13.9
	kW	5.08	5.18	5.33	5.5	5.45	5.56	5.73	5.9	5.78	5.90	6.08	6.3	6.07	6.19	6.39	6.6	6.31	6.45	6.65	6.9	6.31	6.45	6.65	6.9	6.52	6.67	6.88	7.1
	HI PR	236	253	268	279.2	264	284	300	313.3	301	323	342	356.3	342	368	389	405.8	385	414	438	456.5	385	414	438	456.5	426	458	484	504.4
	LO PR	109	116	127	135.0	115	123	134	142.7	120	128	139	148.3	126	134	146	155.8	132	140	153	163.2	132	140	153	163.2	136	145	159	168.8
2650	MBh	69.9	71.4	76.3	81.6	68.3	69.8	74.6	79.7	66.7	68.1	72.8	77.8	65.0	66.5	71.0	75.9	61.8	63.1	67.5	72.1	61.8	63.1	67.5	72.1	57.2	58.5	62.5	66.8
	S/T	0.85	0.80	0.65	0.5	0.88	0.82	0.67	0.5	0.90	0.85	0.69	0.5	0.93	0.87	0.71	0.5	0.97	0.91	0.74	0.6	0.97	0.91	0.74	0.6	0.97	0.91	0.74	0.6
	ΔT	23	22	19	15	23	22	20	16	23	23	20	16	24	23	20	16	23	22	19	16	23	22	19	16	22	21	18	14.5
	kW	5.04	5.14	5.29	5.5	5.41	5.52	5.69	5.9	5.73	5.85	6.03	6.2	6.02	6.15	6.34	6.5	6.26	6.40	6.60	6.8	6.26	6.40	6.60	6.8	6.47	6.61	6.82	7.0
	HI PR	233	251	265	276.4	262	282	297	310.2	298	320	338	352.7	339	365	385	401.8	381	410	433	452.0	381	410	433	452.0	421	453	479	499.4
	LO PR	108	115	126	133.7	114	121	133	141.3	119	126	138	146.8	125	133	145	154.2	131	139	152	161.6	131	139	152	161.6	135	144	157	167.2
2050	MBh	64.5	65.9	70.4	75.3	63.0	64.4	68.8	73.6	61.5	62.9	67.2	71.8	60.0	61.3	65.5	70.1	57.0	58.3	62.3	66.6	57.0	58.3	62.3	66.6	52.8	54.0	57.7	61.6
	S/T	0.82	0.77	0.62	0.5	0.85	0.79	0.65	0.5	0.87	0.81	0.66	0.5	0.90	0.84	0.68	0.5	0.93	0.87	0.71	0.5	0.93	0.87	0.71	0.5	0.94	0.88	0.72	0.5
	ΔT	24	23	20	16	24	23	20	16	24	23	20	16	24	23	20	16	24	23	20	16	24	23	20	16	22	21	19	14.8
	kW	4.92	5.02	5.17	5.3	5.28	5.39	5.55	5.7	5.60	5.71	5.89	6.1	5.87	6.00	6.19	6.4	6.11	6.24	6.44	6.6	6.11	6.24	6.44	6.6	6.31	6.45	6.66	6.9
	HI PR	226	243	257	268.1	254	273	288	300.9	289	311	328	342.2	329	354	374	389.7	370	398	420	438.4	370	398	420	438.4	409	440	464	484.4
	LO PR	105	112	122	129.7	111	118	129	137.0	115	122	134	142.4	121	129	140	149.6	127	135	147	156.8	127	135	147	156.8	131	139	152	162.2

2650	MBh	73.3	74.7	78.2	83.5	71.6	73.0	76.4	81.5	69.9	71.2	74.6	79.6	68.2	69.5	72.8	77.6	64.7	66.0	69.1	73.7	64.7	66.0	69.1	73.7	60.0	61.1	64.0	68.3
	S/T	0.93	0.90	0.81	0.7	0.97	0.93	0.84	0.7	0.99	0.96	0.86	0.7	1.00	0.99	0.89	0.7	1.00	1.00	0.92	0.7	1.00	1.00	0.92	0.7	1.00	1.00	0.93	0.8
	ΔT	24	23	22	19	24	24	22	19	24	24	22	19	24	24	22	19	22	23	22	19	22	23	22	19	21	21	21	17.9
	kW	5.11	5.22	5.37	5.5	5.49	5.60	5.78	6.0	5.82	5.94	6.13	6.3	6.11	6.24	6.44	6.6	6.36	6.50	6.71	6.9	6.36	6.50	6.71	6.9	6.58	6.72	6.94	7.2
	HI PR	238	256	270	282.0	267	287	303	316.4	304	327	345	359.8	346	372	393	409.8	389	419	442	461.1	389	419	442	461.1	430	463	488	509.4
	LO PR	110	117	128	136.4	116	124	135	144.1	121	129	141	149.8	127	135	148	157.3	133	142	155	164.9	133	142	155	164.9	138	147	160	170.5
2350	MBh	71.1	72.5	75.9	81.0	69.5	70.8	74.2	79.1	67.8	69.1	72.4	77.3	66.2	67.5	70.6	75.4	62.9	64.1	67.1	71.6	62.9	64.1	67.1	71.6	58.2	59.4	62.2	66.3
	S/T	0.89	0.86	0.77	0.6	0.92	0.89	0.80	0.7	0.94	0.91	0.82	0.7	0.98	0.94	0.85	0.7	1.00	0.98	0.88	0.7	1.00	0.98	0.88	0.7	1.00	0.98	0.89	0.7
	ΔT	25	24	23	20	25	25	23	20	25	25	23	20	25	25	23	20	25	24	23	20	25	24	23	20	23	23	22	18.7
	kW	5.08	5.18	5.33	5.5	5.45	5.56	5.73	5.9	5.78	5.90	6.08	6.3	6.07	6.19	6.39	6.6	6.31	6.45	6.65	6.9	6.31	6.45	6.65	6.9	6.52	6.67	6.88	7.1
	HI PR	236	253	268	279.2	264	284	300	313.3	301	323	342	356.3	342	368	389	405.8	385	414	438	456.5	385	414	438	456.5	426	458	484	504.4
	LO PR	109	116	127	135.0	115	123	134	142.7	120	128	139	148.3	126	134	146	155.8	132	140	153	163.2	132	140	153	163.2	136	145	159	168.8
2050	MBh	65.7	66.9	70.1	74.8	64.1	65.4	68.5	73.0	62.6	63.8	66.8	71.3	61.1	62.3	65.2	69.6	58.0	59.1	61.9	66.1	58.0	59.1	61.9	66.1	53.7	54.8	57.4	61.2
	S/T	0.86	0.83	0.75	0.6	0.89	0.86	0.77	0.6	0.91	0.88	0.79	0.6	0.94	0.91	0.82	0.7	0.98	0.94	0.85	0.7	0.98	0.94	0.85	0.7	0.98	0.95	0.86	0.7
	ΔT	25	25	23	20	26	25	24	21	26	25	24	21	26	25	24	21	25	25	24	20	25	25	24	20	24	23	22	19.1
	kW	4.96	5.06	5.21	5.4	5.32	5.43	5.60	5.8	5.64	5.76	5.94	6.1	5.92	6.05	6.24	6.4	6.16	6.29	6.49	6.7	6.16	6.29	6.49	6.7	6.37	6.50	6.71	6.9
	HI PR	228	246	260	270.8	256	276	291	303.9	292	314	331	345.6	332	357	377	393.6	374	402	425	442.8	374	402	425	442.8	413	444	469	489.3
	LO PR	106	113	123	131.0	112	119	130	138.4	116	124	135	143.8	122	130	142	151.1	128	136	149	158.3	128	136	149	158.3	132	141	154	163.8

kW = Total system power
Amps: Unit amps (comp.+ evaporator + condenser fan motors)

Shaded area reflects AHRI Ratings conditions

IDB = Entering Indoor Dry Bulb Temperature
High and low pressures are measured at the liquid and suction service ports.

EXPANDED COOLING DATA — 6 TONS - 2 SPEED

IDB		OUTDOOR AMBIENT TEMPERATURE																							
		65°F				75°F				85°F				95°F				105°F				115°F			
		ENTERING INDOOR WET BULB TEMPERATURE																							
AIRFLOW	59	63	67	71	59	63	67	71	59	63	67	71	59	63	67	71	59	63	67	71	59	63	67	71	
2525	MBh	68.6	71.1	77.9	-	67.0	69.4	76.1	-	65.4	67.8	74.3	-	63.8	66.1	72.5	-	60.6	62.8	68.8	-	56.2	58.2	63.8	-
	S/T	0.72	0.60	0.42	-	0.75	0.63	0.43	-	0.77	0.64	0.44	-	0.79	0.66	0.46	-	0.82	0.69	0.48	-	0.83	0.69	0.48	-
	Delta T	18	16	12	-	18	16	12	-	18	16	12	-	18	16	12	-	18	16	12	-	17	15	11	-
	KW	4.91	5.01	5.15	-	5.26	5.37	5.53	-	5.57	5.68	5.85	-	5.84	5.96	6.14	-	6.07	6.20	6.39	-	6.27	6.40	6.60	-
	HI PR	231	248	262	-	259	279	294	-	294	317	335	-	335	361	381	-	377	406	429	-	417	449	474	-
	LO PR	110	117	128	-	116	124	135	-	121	129	140	-	127	135	147	-	133	142	155	-	138	146	160	-
70	MBh	66.6	69.0	75.6	-	65.0	67.4	73.9	-	63.5	65.8	72.1	-	62.0	64.2	70.4	-	58.9	61.0	66.8	-	54.5	56.5	61.9	-
	S/T	0.69	0.58	0.40	-	0.71	0.60	0.41	-	0.73	0.61	0.42	-	0.76	0.63	0.44	-	0.79	0.66	0.45	-	0.79	0.66	0.46	-
	Delta T	19	16	12	-	19	16	12	-	19	16	12	-	19	17	13	-	19	16	12	-	18	15	12	-
	KW	4.88	4.97	5.12	-	5.22	5.33	5.48	-	5.53	5.64	5.81	-	5.80	5.91	6.10	-	6.02	6.15	6.34	-	6.22	6.35	6.55	-
	HI PR	228	246	260	-	256	276	291	-	292	314	331	-	332	357	377	-	374	402	424	-	413	444	469	-
	LO PR	109	116	127	-	115	123	134	-	120	127	139	-	126	134	146	-	132	140	153	-	136	145	158	-
1991	MBh	63.3	65.6	71.8	-	61.8	64.0	70.2	-	60.3	62.5	68.5	-	58.9	61.0	66.8	-	55.9	57.9	63.5	-	51.8	53.7	58.8	-
	S/T	0.66	0.55	0.38	-	0.68	0.57	0.40	-	0.70	0.59	0.41	-	0.72	0.61	0.42	-	0.75	0.63	0.44	-	0.76	0.63	0.44	-
	Delta T	19	17	13	-	20	17	13	-	20	17	13	-	20	17	13	-	19	17	13	-	18	16	12	-
	KW	4.81	4.90	5.04	-	5.14	5.25	5.40	-	5.44	5.55	5.72	-	5.71	5.82	6.00	-	5.93	6.05	6.24	-	6.12	6.25	6.45	-
	HI PR	224	241	254	-	251	270	285	-	286	307	325	-	325	350	370	-	366	394	416	-	404	435	460	-
	LO PR	107	114	124	-	113	120	131	-	117	125	136	-	123	131	143	-	129	137	150	-	134	142	155	-
2525	MBh	69.8	71.8	77.7	83.4	68.1	70.2	75.9	81.5	66.5	68.5	74.1	79.6	64.9	66.8	72.3	77.6	61.6	63.5	68.7	73.7	57.1	58.8	63.6	68.3
	S/T	0.82	0.74	0.56	0.36	0.85	0.76	0.58	0.37	0.87	0.78	0.59	0.38	0.90	0.81	0.61	0.39	0.94	0.84	0.63	0.41	0.94	0.84	0.64	0.41
	Delta T	21	19	16	11	21	19	16	11	21	19	16	11	21	20	16	11	21	19	16	11	20	18	15	10
	KW	4.95	5.05	5.19	5.35	5.30	5.41	5.57	5.74	5.61	5.73	5.90	6.08	5.89	6.01	6.19	6.39	6.12	6.25	6.44	6.65	6.32	6.45	6.66	6.87
	HI PR	233	251	265	276	262	281	297	310	297	320	338	353	339	365	385	402	381	410	433	452	421	453	479	499
	LO PR	111	118	129	138	118	125	136	145	122	130	142	151	128	136	149	159	134	143	156	166	139	148	161	172
2250	MBh	67.7	69.7	75.5	81.0	66.2	68.1	73.7	79.1	64.6	66.5	72.0	77.2	63.0	64.9	70.2	75.4	59.9	61.6	66.7	71.6	55.4	57.1	61.8	66.3
	S/T	0.78	0.70	0.53	0.34	0.81	0.73	0.55	0.35	0.83	0.75	0.56	0.36	0.86	0.77	0.58	0.37	0.89	0.80	0.60	0.39	0.90	0.81	0.61	0.39
	Delta T	22	20	16	11	22	20	17	11	22	20	17	11	22	20	17	12	22	20	16	11	20	19	15	11
	KW	4.91	5.01	5.15	5.31	5.26	5.37	5.53	5.70	5.57	5.68	5.86	6.04	5.84	5.96	6.15	6.34	6.07	6.20	6.39	6.59	6.27	6.40	6.60	6.82
	HI PR	231	248	262	274	259	279	294	307	294	317	335	349	335	361	381	398	377	406	429	447	417	449	474	494
	LO PR	110	117	128	136	116	124	135	144	121	129	140	150	127	135	148	157	133	142	155	165	138	146	160	170
1991	MBh	64.3	66.2	71.7	77.0	62.8	64.7	70.0	75.2	61.3	63.2	68.4	73.4	59.9	61.6	66.7	71.6	56.9	58.5	63.4	68.0	52.7	54.2	58.7	63.0
	S/T	0.75	0.67	0.51	0.33	0.78	0.70	0.53	0.34	0.80	0.71	0.54	0.35	0.82	0.74	0.56	0.36	0.86	0.76	0.58	0.37	0.86	0.77	0.58	0.38
	Delta T	22	21	17	12	23	21	17	12	23	21	17	12	23	21	17	12	22	21	17	12	21	19	16	11
	KW	4.84	4.93	5.08	5.23	5.18	5.29	5.44	5.61	5.48	5.60	5.76	5.94	5.75	5.87	6.05	6.24	5.98	6.10	6.29	6.49	6.17	6.30	6.50	6.71
	HI PR	226	243	257	268	254	273	288	301	289	311	328	342	329	354	374	390	370	398	420	438	409	440	464	484
	LO PR	108	115	125	133	114	121	132	141	118	126	138	147	124	132	145	154	130	139	151	161	135	144	157	167

Shaded area reflects ACCA (TVA) conditions
 kW = Total system power
 Amps: Unit amps (comp.+ evaporator + condenser fan motors)

IDB = Entering Indoor Dry Bulb Temperature
 High and low pressures are measured at the liquid and suction service ports.

IDB		OUTDOOR AMBIENT TEMPERATURE																												
		65°F				75°F				85°F				95°F				105°F				115°F								
		59	63	67	71	59	63	67	71	59	63	67	71	59	63	67	71	59	63	67	71	59	63	67	71					
2525		AIRFLOW	71.0	72.5	77.5	82.9	69.3	70.9	75.7	80.9	67.7	69.2	73.9	79.0	66.0	67.5	72.1	77.1	62.7	64.1	68.5	73.2	62.7	64.1	68.5	73.2	58.1	59.4	63.4	67.8
		MBh	0.90	0.85	0.69	0.51	0.93	0.88	0.71	0.53	0.96	0.90	0.73	0.55	1.00	0.93	0.75	0.56	1.00	0.96	0.78	0.59	1.00	0.96	0.78	0.59	1.00	0.97	0.79	0.59
		S/T	23	22	19	16	24	23	20	16	24	23	20	16	24	23	20	16	23	22	20	16	23	22	20	16	21	21	18	15
		Delta T	4.99	5.08	5.23	5.39	5.34	5.45	5.61	5.78	5.66	5.77	5.95	6.13	5.93	6.06	6.24	6.44	6.17	6.30	6.49	6.70	6.17	6.30	6.49	6.70	6.37	6.51	6.71	6.93
		KW	235	253	268	279	264	284	300	313	300	323	341	356	342	368	389	406	385	414	437	456	385	414	437	456	425	458	483	504
		HI PR	112	120	130	139	119	126	138	147	123	131	143	153	130	138	150	160	136	144	158	168	136	144	158	168	140	149	163	174
		LO PR	68.9	70.4	75.3	80.4	67.3	68.8	73.5	78.6	65.7	67.2	71.8	76.7	64.1	65.5	70.0	74.8	60.9	62.2	66.5	71.1	60.9	62.2	66.5	71.1	56.4	57.7	61.6	65.9
		MBh	0.86	0.81	0.66	0.49	0.89	0.84	0.68	0.51	0.91	0.86	0.70	0.52	0.94	0.88	0.72	0.54	0.98	0.92	0.75	0.56	0.98	0.92	0.75	0.56	0.99	0.93	0.75	0.56
		S/T	24	23	20	16	25	23	20	16	25	24	20	16	25	24	21	16	24	23	20	16	24	23	20	16	23	22	19	15
		Delta T	4.95	5.05	5.19	5.35	5.30	5.41	5.57	5.74	5.61	5.73	5.90	6.08	5.89	6.01	6.19	6.39	6.12	6.25	6.44	6.65	6.12	6.25	6.44	6.65	6.32	6.45	6.66	6.87
		KW	233	251	265	276	262	281	297	310	297	320	338	353	339	365	385	402	381	410	433	452	381	410	433	452	421	453	479	499
		HI PR	111	118	129	138	118	125	136	145	122	130	142	151	128	136	149	159	134	143	156	166	134	143	156	166	139	148	162	172
		LO PR	65.5	66.9	71.5	76.4	64.0	65.4	69.8	74.6	62.4	63.8	68.2	72.9	60.9	62.2	66.5	71.1	57.9	59.1	63.2	67.5	57.9	59.1	63.2	67.5	53.6	54.8	58.5	62.6
		MBh	0.82	0.77	0.63	0.47	0.85	0.80	0.65	0.49	0.88	0.82	0.67	0.50	0.90	0.85	0.69	0.52	0.94	0.88	0.72	0.54	0.94	0.88	0.72	0.54	0.95	0.89	0.72	0.54
		S/T	25	24	21	17	25	24	21	17	25	24	21	17	25	24	21	17	25	24	21	17	25	24	21	17	23	22	20	16
		Delta T	4.88	4.97	5.12	5.27	5.22	5.33	5.48	5.65	5.53	5.64	5.81	5.99	5.80	5.91	6.10	6.29	6.02	6.15	6.34	6.54	6.02	6.15	6.34	6.54	6.22	6.35	6.55	6.76
		KW	228	246	260	271	256	276	291	304	292	314	331	346	332	357	377	394	374	402	424	443	374	402	424	443	413	444	469	489
		HI PR	109	116	127	135	115	123	134	142	120	127	139	148	126	134	146	156	132	140	153	163	132	140	153	163	136	145	158	169
		LO PR																												

		MBh	72.2	73.6	77.1	82.3	70.6	71.9	75.3	80.4	68.9	70.2	73.5	78.4	67.2	68.5	71.7	76.5	63.8	65.1	68.2	72.7	63.8	65.1	68.2	72.7	59.1	60.3	63.1	67.4
		S/T	0.95	0.91	0.82	0.67	0.98	0.95	0.85	0.69	1.00	0.97	0.87	0.71	1.00	1.00	0.90	0.73	1.00	1.00	0.94	0.76	1.00	1.00	0.94	0.76	1.00	1.00	0.94	0.77
		Delta T	25	24	23	20	25	25	23	20	25	25	23	20	24	25	24	20	23	24	23	20	23	24	23	20	22	22	22	19
		KW	5.02	5.12	5.27	5.43	5.38	5.49	5.65	5.83	5.70	5.82	5.99	6.18	5.98	6.10	6.29	6.49	6.22	6.35	6.55	6.76	6.22	6.35	6.55	6.76	6.42	6.56	6.77	6.98
		HI PR	238	256	270	282	267	287	303	316	303	327	345	360	346	372	393	410	389	418	442	461	389	418	442	461	430	462	488	509
		LO PR	113	121	132	140	120	128	139	148	125	133	145	154	131	139	152	162	137	146	159	170	137	146	159	170	142	151	165	175
		MBh	70.1	71.5	74.9	79.9	68.5	69.8	73.1	78.0	66.9	68.2	71.4	76.2	65.2	66.5	69.7	74.3	62.0	63.2	66.2	70.6	62.0	63.2	66.2	70.6	57.4	58.5	61.3	65.4
		S/T	0.90	0.87	0.79	0.64	0.93	0.90	0.81	0.66	0.96	0.92	0.83	0.68	0.99	0.95	0.86	0.70	1.00	0.99	0.89	0.73	1.00	0.99	0.89	0.73	1.00	1.00	0.90	0.73
		Delta T	26	25	24	21	26	26	24	21	26	26	24	21	26	26	25	21	25	26	24	21	25	26	24	21	23	24	23	20
		KW	4.99	5.08	5.23	5.39	5.34	5.45	5.61	5.78	5.66	5.77	5.95	6.13	5.93	6.06	6.24	6.44	6.17	6.30	6.49	6.70	6.17	6.30	6.49	6.70	6.37	6.51	6.71	6.93
		HI PR	235	253	268	279	264	284	300	313	300	323	341	356	342	368	389	406	385	414	437	456	385	414	437	456	425	458	483	504
		LO PR	112	120	130	139	119	126	138	147	123	131	143	153	130	138	150	160	136	144	158	168	136	144	158	168	140	149	163	174
		MBh	66.6	67.9	71.1	75.9	65.1	66.3	69.5	74.1	63.5	64.8	67.8	72.4	62.0	63.2	66.2	70.6	58.9	60.0	62.9	67.1	58.9	60.0	62.9	67.1	54.5	55.6	58.2	62.1
		S/T	0.86	0.83	0.75	0.61	0.89	0.86	0.78	0.63	0.92	0.89	0.80	0.65	0.95	0.91	0.82	0.67	0.98	0.95	0.86	0.69	0.98	0.95	0.86	0.69	0.99	0.96	0.86	0.70
		Delta T	27	26	25	21	27	26	25	22	27	26	25	22	27	27	25	22	27	26	25	22	27	26	25	22	25	25	23	20
		KW	4.91	5.01	5.15	5.31	5.26	5.37	5.53	5.69	5.57	5.68	5.85	6.04	5.84	5.96	6.14	6.34	6.07	6.20	6.39	6.59	6.07	6.20	6.39	6.59	6.27	6.40	6.60	6.81
		HI PR	231	248	262	273	259	279	294	307	294	317	335	349	335	361	381	397	377	406	429	447	377	406	429	447	417	449	474	494
		LO PR	110	117	128	136	116	124	135	144	121	129	140	150	127	135	147	157	133	142	155	165	133	142	155	165	138	146	160	170

kW = Total system power
Amps: Unit amps (comp.+ evaporator + condenser fan motors)

Shaded area reflects AHRI Ratings conditions

IDB = Entering Indoor Dry Bulb Temperature
High and low pressures are measured at the liquid and suction service ports.

DIRECT DRIVE — HORIZONTAL

CFM	STATIC	AMPS	WATTS	RPM	SPEED TAP
1296	0.1	1.67	356	764	Low
1245	0.2	1.60	334	830	
1174	0.3	1.56	325	861	
1103	0.4	1.52	316	891	
1013	0.5	1.46	300	935	
1502	0.1	2.10	456	836	Med
1449	0.2	2.06	444	864	
1396	0.3	2.02	432	891	
1335	0.4	1.97	418	916	
1273	0.5	1.91	404	940	
1153	0.6	1.83	380	973	
996	0.7	1.71	346	1017	
1516	0.2	2.36	506	940	High
1454	0.3	2.31	496	960	
1392	0.4	2.26	486	979	
1273	0.5	2.17	458	1006	
1183	0.6	2.09	441	1023	
1092	0.7	2.02	424	1039	
920	0.8	1.90	390	1067	

DIRECT DRIVE — DOWN SHOT

CFM	STATIC	AMPS	WATTS	RPM	SPEED TAP
1287	0.1	1.66	350	770	Low
1233	0.2	1.63	342	815	
1176	0.3	1.59	332	858	
1107	0.4	1.55	320	891	
1044	0.5	1.51	312	924	
965	0.6	1.45	296	957	
1476	0.1	2.08	446	866	Med
1421	0.2	2.03	432	885	
1334	0.3	1.96	414	918	
1255	0.4	1.90	396	945	
1180	0.5	1.84	386	971	
1085	0.6	1.78	368	990	
964	0.7	1.70	344	1023	
1455	0.3	2.31	490	962	High
1367	0.4	2.25	476	984	
1277	0.5	2.16	454	1006	
1180	0.6	2.09	438	1025	
1080	0.7	2.02	418	1039	
922	0.8	1.90	386	1067	

Notes:

- Assumes dry coil with filter in place
- SCFM correction for wet coil = 4%

STANDARD BELT DRIVE — HORIZONTAL

ESP (" W.C.)	TURNS OPEN											
	0		1		2		3		4		5	
	CFM	BHP	CFM	BHP	CFM	BHP	CFM	BHP	CFM	BHP	CFM	BHP
0.2	---	---	---	---	---	---	---	---	1658	0.35	1489	0.28
0.4	---	---	---	---	---	---	1560	0.36	1339	0.28	1129	0.21
0.6	---	---	1682	0.47	1436	0.36	1196	0.27	949	0.19	---	---
0.8	1581	0.50	1354	0.38	1096	0.28	828	0.18	---	---	---	---
1.0	1266	0.39	994	0.28	756	0.19	---	---	---	---	---	---
1.2	923	0.28	---	---	---	---	---	---	---	---	---	---

HIGH-STATIC BELT DRIVE — HORIZONTAL

ESP (" W.C.)	TURNS OPEN											
	0		1		2		3		4		5	
	CFM	BHP	CFM	BHP	CFM	BHP	CFM	BHP	CFM	BHP	CFM	BHP
0.6	---	---	---	---	---	---	---	---	1742	0.50	1431	0.36
0.8	---	---	---	---	---	---	1626	0.52	1357	0.39	1078	0.27
1.0	---	---	---	---	1611	0.56	1315	0.42	1011	0.28	---	---
1.2	---	---	1605	0.62	1299	0.46	976	0.31	---	---	---	---
1.4	1605	0.68	1281	0.51	959	0.35	---	---	---	---	---	---
1.6	1281	0.57	981	0.41	---	---	---	---	---	---	---	---
1.8	981	0.47	---	---	---	---	---	---	---	---	---	---

STANDARD BELT DRIVE — DOWN SHOT

ESP (" W.C.)	TURNS OPEN											
	0		1		2		3		4		5	
	CFM	BHP	CFM	BHP	CFM	BHP	CFM	BHP	CFM	BHP	CFM	BHP
0.2	---	---	---	---	---	---	---	---	1424	0.30	1239	0.23
0.4	---	---	---	---	1520	0.39	1292	0.29	1073	0.22	779	0.14
0.6	---	---	1439	0.40	1192	0.30	944	0.21	619	0.12	---	---
0.8	1350	0.42	1101	0.31	864	0.22	---	---	---	---	---	---
1.0	1028	0.31	729	0.21	---	---	---	---	---	---	---	---
1.2	675	0.20	---	---	---	---	---	---	---	---	---	---

HIGH-STATIC BELT DRIVE — DOWN SHOT

ESP (" W.C.)	TURNS OPEN											
	0		1		2		3		4		5	
	CFM	BHP	CFM	BHP	CFM	BHP	CFM	BHP	CFM	BHP	CFM	BHP
0.6	---	---	---	---	---	---	1692	0.54	1449	0.41	1173	0.29
0.8	---	---	---	---	1678	0.58	1397	0.44	1107	0.31	854	0.21
1.0	---	---	1681	0.65	1381	0.49	1078	0.34	794	0.22	---	---
1.2	1681	0.71	1362	0.54	1062	0.39	---	---	---	---	---	---
1.4	1362	0.60	1066	0.44	---	---	---	---	---	---	---	---
1.6	1066	0.50	789	0.34	---	---	---	---	---	---	---	---
1.8	789	0.40	---	---	---	---	---	---	---	---	---	---

STANDARD DIRECT DRIVE — HORIZONTAL

CFM	STATIC	AMPS	WATTS	RPM	SPEED TAP
1622	0.1	2.54	539	809	Low
1558	0.2	2.43	517	852	
1494	0.3	2.32	495	895	
1410	0.4	2.21	471	924	
1326	0.5	2.10	447	953	
1861	0.1	3.11	670	886	Med
1733	0.2	2.78	606	918	
1639	0.3	2.64	568	960	
1564	0.4	2.51	542	984	
1434	0.5	2.35	508	1017	
1320	0.6	2.25	482	1039	
1156	0.7	2.08	446	1067	
1984	0.1	3.34	734	949	High
1883	0.2	3.18	694	977	
1770	0.3	3.03	654	1001	
1656	0.4	2.87	620	1027	
1540	0.5	2.76	590	1044	
1415	0.6	2.62	558	1061	

STANDARD DIRECT DRIVE — DOWN SHOT

CFM	STATIC	AMPS	WATTS	RPM	SPEED TAP
1602	0.1	2.48	528	835	Low
1538	0.2	2.37	506	878	
1474	0.3	2.26	484	921	
1390	0.4	2.15	460	950	
1306	0.5	2.04	436	979	
1805	0.1	2.84	620	935	Med
1704	0.2	2.71	590	967	
1625	0.3	2.59	558	990	
1549	0.4	2.47	540	1012	
1437	0.5	2.38	516	1030	
1301	0.6	2.23	480	1050	
1158	0.7	2.09	444	1072	High
1971	0.1	3.22	706	968	
1828	0.2	3.03	664	998	
1744	0.3	2.94	632	1017	
1628	0.4	2.80	606	1034	
1510	0.5	2.69	582	1050	
1402	0.6	2.57	552	1067	

Notes:

- Assumes dry coil with filter in place
- SCFM correction for wet coil = 4%

STANDARD BELT DRIVE — HORIZONTAL

ESP (" W.C.)	0 TURNS		1 TURN		2 TURNS		3 TURNS		4 TURNS		5 TURNS	
	CFM	BHP	CFM	BHP	CFM	BHP	CFM	BHP	CFM	BHP	CFM	BHP
0.2	---	---	---	---	---	---	---	---	1943	0.52	1714	0.40
0.4	---	---	---	---	2187	0.72	1876	0.55	1566	0.40	1270	0.26
0.6	---	---	2044	0.72	1761	0.56	1444	0.40	1136	0.26	---	---
0.8	1947	0.74	1704	0.59	1335	0.40	---	---	---	---	---	---
1.0	1598	0.60	1275	0.36	---	---	---	---	---	---	---	---
1.2	1208	0.45	---	---	---	---	---	---	---	---	---	---

HIGH-STATIC BELT DRIVE — HORIZONTAL

ESP (" W.C.)	0 TURNS		1 TURN		2 TURNS		3 TURNS		4 TURNS		5 TURNS	
	CFM	BHP	CFM	BHP	CFM	BHP	CFM	BHP	CFM	BHP	CFM	BHP
0.6	---	---	---	---	---	---	---	---	2056	0.72	1721	0.54
0.8	---	---	---	---	---	---	1996	0.77	1662	0.57	1328	0.40
1.0	---	---	---	---	1924	0.79	1603	0.61	1270	0.43	---	---
1.2	---	---	1952	0.88	1559	0.64	1210	0.44	---	---	---	---
1.4	1888	0.92	1543	0.70	1195	0.49	---	---	---	---	---	---
1.6	1557	0.77	1180	0.54	---	---	---	---	---	---	---	---
1.8	1192	0.60	---	---	---	---	---	---	---	---	---	---

STANDARD BELT DRIVE — DOWN SHOT

ESP (" W.C.)	0 TURNS		1 TURN		2 TURNS		3 TURNS		4 TURNS		5 TURNS	
	CFM	BHP	CFM	BHP	CFM	BHP	CFM	BHP	CFM	BHP	CFM	BHP
0.2	---	---	---	---	---	---	2129	0.64	1795	0.47	1550	0.35
0.4	---	---	---	---	1994	0.65	1701	0.49	1433	0.36	1163	0.22
0.6	---	---	1905	0.67	1606	0.50	1326	0.36	1025	0.22	---	---
0.8	1808	0.69	1565	0.54	1216	0.36	---	---	---	---	---	---
1.0	1473	0.55	1137	0.32	---	---	---	---	---	---	---	---
1.2	1103	0.41	---	---	---	---	---	---	---	---	---	---

HIGH-STATIC BELT DRIVE — DOWN SHOT

ESP (" W.C.)	0 TURNS		1 TURN		2 TURNS		3 TURNS		4 TURNS		5 TURNS	
	CFM	BHP	CFM	BHP	CFM	BHP	CFM	BHP	CFM	BHP	CFM	BHP
0.6	---	---	---	---	---	---	2194	0.85	1886	0.66	1580	0.49
0.8	---	---	---	---	2113	0.86	1832	0.70	1526	0.52	1219	0.37
1.0	---	---	2182	0.98	1776	0.73	1472	0.55	1166	0.39	---	---
1.2	2053	1.00	1780	0.80	1440	0.59	1111	0.40	---	---	---	---
1.4	1759	0.86	1421	0.64	1104	0.46	---	---	---	---	---	---
1.6	1442	0.72	1095	0.50	---	---	---	---	---	---	---	---
1.8	1095	0.56	---	---	---	---	---	---	---	---	---	---

STANDARD DIRECT DRIVE MOTOR — HORIZONTAL

CFM	STATIC	AMPS	WATTS	RPM	SPEED TAP
1355	0.1	1.57	174	599	T1
1281	0.2	1.66	182	651	
1235	0.3	1.76	196	693	
1168	0.4	1.81	202	726	
1118	0.5	1.94	218	775	
1049	0.6	2.03	232	819	
982	0.7	2.10	240	858	
922	0.8	2.14	246	885	
871	0.9	2.25	260	927	
1544	0.1	2.04	234	660	
1490	0.2	2.17	250	704	
1427	0.3	2.25	260	742	
1370	0.4	2.35	276	781	
1319	0.5	2.42	282	809	
1274	0.6	2.52	296	849	
1210	0.7	2.62	316	891	
1137	0.8	2.73	326	935	
1106	0.9	2.77	336	957	
2099	0.1	4.13	516	825	T3
2068	0.2	4.25	536	852	
2029	0.3	4.37	552	885	
1971	0.4	4.48	568	913	
1911	0.5	4.61	586	950	
1876	0.6	4.73	604	973	
1821	0.7	4.86	622	1012	
1792	0.8	4.91	630	1028	
1740	0.9	5.03	648	1067	
2233	0.1	4.76	608	863	
2168	0.2	4.91	628	896	
2125	0.3	5.02	640	924	
2070	0.4	5.14	660	951	
2050	0.5	5.27	678	979	
1980	0.6	5.41	696	1012	
1954	0.7	5.47	704	1034	
1893	0.8	5.60	724	1067	
1852	0.9	5.70	736	1089	
2322	0.1	5.44	710	904	T5
2294	0.2	5.55	726	934	
2254	0.3	5.68	742	958	
2201	0.4	5.80	766	990	
2147	0.5	5.93	782	1017	
2117	0.6	6.01	788	1039	
2081	0.7	6.12	808	1060	
2017	0.8	6.22	822	1094	
1932	0.9	6.10	804	1111	

STANDARD DIRECT DRIVE MOTOR — DOWN SHOT

CFM	STATIC	AMPS	WATTS	RPM	SPEED TAP
1334	0.1	1.65	180	627	T1
1286	0.2	1.75	192	665	
1212	0.3	1.83	202	715	
1144	0.4	1.94	216	759	
1077	0.5	1.99	222	792	
1039	0.6	2.10	238	830	
953	0.7	2.17	248	874	
904	0.8	2.27	258	913	
825	0.9	2.30	266	940	
1512	0.1	2.12	240	682	
1469	0.2	2.24	254	720	
1397	0.3	2.31	264	759	
1333	0.4	2.44	282	803	
1285	0.5	2.54	296	836	
1221	0.6	2.59	304	874	
1173	0.7	2.72	322	913	
1118	0.8	2.77	328	946	
1049	0.9	2.90	344	984	
2053	0.1	4.27	540	869	T3
2014	0.2	4.39	558	896	
1999	0.3	4.60	576	929	
1947	0.4	4.68	588	957	
1897	0.5	4.79	608	989	
1857	0.6	4.87	620	1012	
1763	0.7	4.99	640	1050	
1741	0.8	5.06	650	1072	
1669	0.9	5.19	668	1105	
2137	0.1	4.95	634	913	
2093	0.2	5.07	652	940	
2095	0.3	5.19	670	962	
2026	0.4	5.28	682	990	
1980	0.5	5.40	698	1018	
1961	0.6	5.49	720	1039	
1914	0.7	5.58	732	1072	
1845	0.8	5.70	742	1100	
1766	0.9	5.69	740	1127	
2299	0.1	5.70	742	942	T5
2233	0.2	5.80	748	969	
2217	0.3	5.90	768	990	
2157	0.4	6.07	786	1018	
2131	0.5	6.12	804	1045	
2060	0.6	6.21	816	1073	
2015	0.7	6.30	820	1095	
1940	0.8	6.27	816	1111	
1862	0.9	6.13	790	1128	

NOTES

- Assumes dry coil with filter in place; SCFM correction for wet coil = 4%
- Five-ton models are shipped from the factory with speed tap set on T4.

STANDARD BELT DRIVE — HORIZONTAL

ESP (" W.C.)	TURNS OPEN											
	0		1		2		3		4		5	
	CFM	BHP	CFM	BHP	CFM	BHP	CFM	BHP	CFM	BHP	CFM	BHP
0.2	---	---	---	---	---	---	---	---	2420	0.79	2198	0.64
0.4	---	---	---	---	2605	1.02	2358	0.84	2133	0.67	1874	0.52
0.6	---	---	2526	1.06	2300	0.88	2026	0.70	1806	0.55	---	---
0.8	2529	1.15	2252	0.93	1975	0.73	1670	0.54	---	---	---	---
1.0	2233	0.99	1943	0.78	1628	0.57	---	---	---	---	---	---
1.2	1907	0.83	1582	0.61	---	---	---	---	---	---	---	---

HIGH-STATIC BELT DRIVE — HORIZONTAL

ESP (" W.C.)	TURNS OPEN											
	0		1		2		3		4		5	
	CFM	BHP	CFM	BHP	CFM	BHP	CFM	BHP	CFM	BHP	CFM	BHP
0.6	---	---	---	---	---	---	---	---	---	---	2323	0.92
0.8	---	---	---	---	---	---	---	---	2315	1.00	2009	0.77
1.0	---	---	---	---	---	---	2308	1.09	1992	0.84	1666	0.60
1.2	---	---	---	---	2338	1.21	1992	0.92	1646	0.66	---	---
1.4	---	---	2359	1.32	2025	1.02	1648	0.72	---	---	---	---
1.6	2404	1.45	2056	1.13	1684	0.82	---	---	---	---	---	---
1.8	2088	1.24	1722	0.92	---	---	---	---	---	---	---	---

STANDARD BELT DRIVE — DOWN SHOT

ESP (" W.C.)	TURNS OPEN											
	0		1		2		3		4		5	
	CFM	BHP	CFM	BHP	CFM	BHP	CFM	BHP	CFM	BHP	CFM	BHP
0.2	---	---	---	---	2579	1.01	2368	0.85	2175	0.69	1961	0.55
0.4	---	---	2513	1.05	2318	0.89	2089	0.73	1906	0.59	1666	0.44
0.6	2514	1.14	2276	0.94	2045	0.77	1797	0.60	1604	0.47	---	---
0.8	2261	1.01	2017	0.82	1760	0.63	---	---	---	---	---	---
1.0	1989	0.87	1730	0.68	---	---	---	---	---	---	---	---
1.2	1695	0.72	---	---	---	---	---	---	---	---	---	---

HIGH-STATIC BELT DRIVE — DOWN SHOT

ESP (" W.C.)	TURNS OPEN											
	0		1		2		3		4		5	
	CFM	BHP	CFM	BHP	CFM	BHP	CFM	BHP	CFM	BHP	CFM	BHP
0.6	---	---	---	---	---	---	---	---	2331	1.01	2072	0.80
0.8	---	---	---	---	---	---	2324	1.10	2059	0.87	1791	0.66
1.0	---	---	---	---	2350	1.21	2058	0.95	1774	0.72	---	---
1.2	---	---	2367	1.33	2086	1.06	1776	0.79	---	---	---	---
1.4	2404	1.45	2111	1.17	1805	0.89	---	---	---	---	---	---
1.6	2136	1.28	1835	0.99	---	---	---	---	---	---	---	---
1.8	1868	1.10	---	---	---	---	---	---	---	---	---	---

STANDARD BELT DRIVE AND TWO-SPEED STANDARD BELT DRIVE AT HIGH SPEED - HORIZONTAL

ESP (IN W.C.)	0 TURNS		1 TURN		2 TURNS		3 TURNS		4 TURNS		5 TURNS	
	CFM	BHP	CFM	BHP	CFM	BHP	CFM	BHP	CFM	BHP	CFM	BHP
0.2	---	---	---	---	---	---	2784	1.30	2582	0.83	2411	0.79
0.4	---	---	---	---	2814	1.34	2620	1.19	2342	0.72	2105	0.66
0.6	---	---	2665	1.34	2583	1.19	2398	1.06	2103	0.62	1902	0.57
0.8	2689	1.38	2492	1.22	2370	1.07	2142	0.91	1816	0.51	---	---
1	2438	1.22	2275	1.09	2098	0.92	1883	0.78	---	---	---	---
1.2	2250	1.10	1996	0.92	---	---	---	---	---	---	---	---

STANDARD BELT DRIVE AND TWO-SPEED STANDARD BELT DRIVE AT HIGH SPEED - DOWN SHOT

ESP (IN W.C.)	0 TURNS		1 TURN		2 TURNS		3 TURNS		4 TURNS		5 TURNS	
	CFM	BHP	CFM	BHP	CFM	BHP	CFM	BHP	CFM	BHP	CFM	BHP
0.2	---	---	---	---	2771	1.27	2567	1.05	2421	0.88	2220	0.71
0.4	---	---	2753	1.38	2573	1.15	2382	0.95	2186	0.77	1980	0.61
0.6	2655	1.42	2548	1.24	2360	1.02	2119	0.81	1934	0.65	---	---
0.8	2470	1.30	2331	1.11	2111	0.89	1868	0.69	---	---	---	---
1	2296	1.18	2078	0.96	1840	0.75	---	---	---	---	---	---
1.2	2040	1.02	---	---	---	---	---	---	---	---	---	---

HIGH-STATIC BELT DRIVE — HORIZONTAL

ESP (IN W.C.)	0 TURNS		1 TURN		2 TURNS		3 TURNS		4 TURNS		5 TURNS	
	CFM	BHP	CFM	BHP	CFM	BHP	CFM	BHP	CFM	BHP	CFM	BHP
0.6	---	---	---	---	---	---	---	---	2746	1.38	2515	1.12
0.8	---	---	---	---	---	---	2721	1.47	2494	1.21	2261	0.97
1	---	---	---	---	2689	1.56	2500	1.32	2255	1.06	1994	0.83
1.2	---	---	2752	1.74	2473	1.40	2252	1.15	1996	0.91	---	---
1.4	2802	1.88	2487	1.53	2286	1.27	2037	1.02	---	---	---	---
1.6	2553	1.67	2308	1.40	1997	1.08	---	---	---	---	---	---
1.8	2355	1.51	2014	1.19	---	---	---	---	---	---	---	---
2	2055	1.29	---	---	---	---	---	---	---	---	---	---

HIGH-STATIC BELT DRIVE — DOWN SHOT

ESP (IN W.C.)	0 TURNS		1 TURN		2 TURNS		3 TURNS		4 TURNS		5 TURNS	
	CFM	BHP	CFM	BHP	CFM	BHP	CFM	BHP	CFM	BHP	CFM	BHP
0.6	---	---	---	---	2793	1.64	2603	1.39	2450	1.18	2270	0.97
0.8	---	---	2903	1.87	2696	1.57	2369	1.23	2236	1.05	1987	0.82
1	2776	1.86	2682.5	1.69	2445	1.38	2196	1.12	1968	0.90	---	---
1.2	2599	1.71	2539	1.57	2310	1.29	1932	0.96	---	---	---	---
1.4	2424	1.57	2305	1.40	2032	1.11	---	---	---	---	---	---
1.6	2172	1.38	2017	1.19	---	---	---	---	---	---	---	---
1.8	1953	1.22	---	---	---	---	---	---	---	---	---	---

AIR FLOW PRESSURE DROP OF DOWN FLOW ECONOMIZER

AIRFLOW PRESSURE DROP OF DOWNFLOW ECONOMIZER FOR 3 TO 6 TON ROFTOP UNITS (100% RETURN AIR)											
SCF,	800	1000	1200	1400	1600	1800	2000	2200	2400	2600	2800
in WG	0.02	0.04	0.05	0.07	0.09	0.12	0.14	0.17	0.21	0.24	0.28

MODEL AND HEAT KIT USAGE	MCA ¹ AT 208 / 240V	MOP ² (AMPS) AT 208 / 240V	ACTUAL kW & BTU AT 240V	RECOMMENDED AIRFLOW RANGE
DCC036***3D***	17	25	---	---
EHK3-10	29 / 33	30 / 35	10	1250-1350 CFM
EHK3-15	42 / 48	45 / 50	15	1400-1440 CFM
DCC036***3B***	18	25	---	---
EHK3-10	30 / 33	35 / 35	10	1250-1350 CFM
EHK3-15	43 / 48	45 / 50	15	1400-1440 CFM

MODEL AND HEAT KIT USAGE	MCA ¹ AT 480V	MOP ² (AMPS) AT 480V	ACTUAL kW & BTU AT 480V	RECOMMENDED AIRFLOW RANGE
DCC036***4B***	10	15	---	---
EHK4-10	17	20	10	1250-1350 CFM
EHK4-15	25	25	15	1400-1440 CFM

MODEL AND HEAT KIT USAGE	MCA ¹ AT 575V	MOP ² (AMPS) AT 575V	ACTUAL kW & BTU AT 575V	RECOMMENDED AIRFLOW RANGE
DCC036***7B***	8	15	---	---
EHK7-10	15	20	10	1250-1350 CFM
EHK7-15	22	25	15	1400-1440 CFM

¹ Minimum Circuit Ampacity

² Maximum Overcurrent Protection device

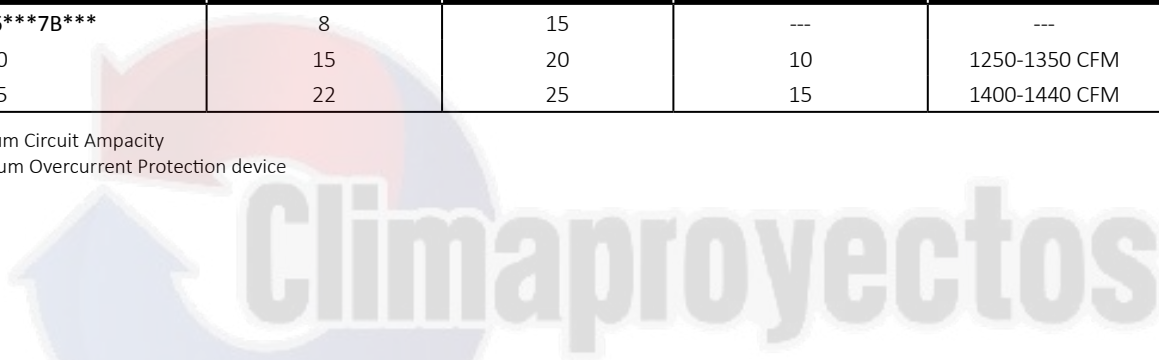

KW CORRECTION FACTOR

kW CORRECTION FACTOR FOR 1- & 3-PHASE UNITS					
SUPPLY VOLTAGE	240	230	220	210	208
CORRECTION FACTOR	1	0.93	0.82	0.78	0.76

Multiply rated kW by correction factor to get actual kW

kW CORRECTION FACTOR FOR 480V UNITS			
ACTUAL VOLTAGE	460	440	430
CORRECTION FACTOR	0.92	0.84	0.8

For other voltage use $\text{voltage}^2 / 480^2$

kW CORRECTION FACTOR FOR 575V UNITS			
SUPPLY VOLTAGE	560	550	540
CORRECTION FACTOR	0.95	0.91	0.88

Multiply rated kW by correction factor to get actual kW

HEATER SIZE	MINIMUM CFM	
	A MODELS	B MODELS
10 kW	1,250	1,250
15 kW	1,400	1,250

MODEL AND HEAT KIT USAGE	MCA ¹ AT 208 / 240V	MOP ² (AMPS) AT 208 / 240V	ACTUAL KW & BTU AT 240V	RECOMMENDED AIRFLOW RANGE
DCC048***3D***	21	30	---	---
EHK3-10	29 / 34	35 / 35	10	1400-1800 CFM
EHK3-15	42 / 49	45 / 50	15	1575-1800 CFM
EHK3-18	50 / 58	60 / 60	18	1575-1800 CFM
DCC048***3B***	22	30	---	---
EHK3-10	30 / 35	35 / 35	10	1400-1800 CFM
EHK3-15	43 / 50	45 / 50	15	1575-1800 CFM
EHK3-18	51 / 59	60 / 60	18	1575-1800 CFM

MODEL AND HEAT KIT USAGE	MCA ¹ AT 480V	MOP ² (AMPS) AT 480V	ACTUAL KW & BTU AT 480V	RECOMMENDED AIRFLOW RANGE
DCC048***4B***	10	15	---	---
EHK4-10	17	20	10	1400-1800 CFM
EHK4-15	25	25	15	1575-1800 CFM
EHK4-18	29	30	18	1575-1800 CFM

MODEL AND HEAT KIT USAGE	MCA ¹ AT 575V	MOP ² (AMPS) AT 575V	ACTUAL KW & BTU AT 575V	RECOMMENDED AIRFLOW RANGE
DCC048***7B***	8	15	---	---
EHK7-10	15	20	10	1400-1800 CFM
EHK7-15	22	25	15	1575-1800 CFM
EHK7-18	25	30	18	1575-1800 CFM

¹ Minimum Circuit Ampacity

² Maximum Overcurrent Protection device

KW CORRECTION FACTOR

KW CORRECTION FACTOR FOR 1- & 3-PHASE UNITS					
SUPPLY VOLTAGE	240	230	220	210	208
CORRECTION FACTOR	1	0.93	0.82	0.78	0.76

Multiply rated kW by correction factor to get actual kW

KW CORRECTION FACTOR FOR 480V UNITS			
ACTUAL VOLTAGE	460	440	430
CORRECTION FACTOR	0.92	0.84	0.8

For other voltage use $\text{voltage}^2 / 480^2$

KW CORRECTION FACTOR FOR 575V UNITS			
SUPPLY VOLTAGE	560	550	540
CORRECTION FACTOR	0.95	0.91	0.88

Multiply rated kW by correction factor to get actual kW.

HEATER SIZE	MINIMUM CFM	
	A MODELS	B MODELS
10 kW	1,400	1,300
15 kW	1,575	1,400
18 kW	1,575	1,400

MODEL AND HEAT KIT USAGE	MCA ¹ AT 208 / 240V	MOP ² (AMPS) AT 208 / 240V	ACTUAL kW & BTU AT 240V	RECOMMENDED AIRFLOW RANGE	SPEED TAP
DCC060***3D***	29	45	---	---	
EHK3-10	34 / 40	35 / 45	10	1750-2250 CFM	T3, T4, T5
EHK3-15	47 / 55	50 / 60	15	1750-2250 CFM	T3, T4, T5
EHK3-20	60 / 70	70 / 70	20	1850-2250 CFM	T5
DCC060***3B***	25	40	---	---	---
EHK3-10	30 / 35	35 / 40	10	1750 - 2250 CFM	---
EHK3-15	43 / 50	45 / 50	15	1750 - 2250 CFM	---
EHK3-20	56 / 65	60 / 70	20	1850 - 2250 CFM	---

MODEL AND HEAT KIT USAGE	MCA ¹ AT 480V	MOP ² (AMPS) AT 480V	ACTUAL kW & BTU AT 480V	RECOMMENDED AIRFLOW RANGE
DCC060***4B***	12	20	---	---
EHK4-10	19	20	10	1750 - 2250 CFM
EHK4-15	25	25	15	1750 - 2250 CFM
EHK4-20	35	35	20	1850 - 2250 CFM

MODEL AND HEAT KIT USAGE	MCA ¹ AT 575V	MOP ² (AMPS) AT 575V	ACTUAL kW & BTU AT 575V	RECOMMENDED AIRFLOW RANGE
DCC060***7B***	10	15	---	---
EHK7-10	15	20	10	1750-2250 CFM
EHK7-15	22	25	15	1750-2250 CFM
EHK7-20	28	30	20	1850-2250 CFM
EHK7-25	34	35	25	---

¹ Minimum Circuit Ampacity

² Maximum Overcurrent Protection Device

KW CORRECTION FACTOR

kW CORRECTION FACTOR FOR 1- & 3-PHASE UNITS					
SUPPLY VOLTAGE	240	230	220	210	208
CORRECTION FACTOR	1	0.93	0.82	0.78	0.76

Multiply rated kW by correction factor to get actual kW

kW CORRECTION FACTOR FOR 480V UNITS			
ACTUAL VOLTAGE	460	440	430
CORRECTION FACTOR	0.92	0.84	0.8

For other voltage use $\text{voltage}^2 / 480^2$

kW CORRECTION FACTOR FOR 575V UNITS			
SUPPLY VOLTAGE	560	550	540
CORRECTION FACTOR	0.95	0.91	0.88

HEATER SIZE	MINIMUM CFM	
	A MODELS	B MODELS
10	1,750	1,700
15	1,750	1,700
20	1,850	1,880

MODEL AND HEAT KIT USAGE	MCA ¹ AT 208 / 240V	MOP ² (AMPS) AT 208 / 240V	ACTUAL kW & BTU AT 240V	RECOMMENDED AIRFLOW RANGE
DCC072***3B***	31	45	---	---
EHK3-10	36	45	10	2,100 - 2,700 CFM
EHK3-15	51	60	15	2,100 - 2,700 CFM
EHK3-20	66	70	20	2,100 - 2,700 CFM
EHK3-25	81	90	25	2,100 - 2,700 CFM

MODEL AND HEAT KIT USAGE	MCA ¹ AT 480V	MOP ² (AMPS) AT 480V	ACTUAL kW & BTU AT 480V	RECOMMENDED AIRFLOW RANGE
DCC072***4B***	16	25	---	---
EHK4-10	18	25	10	2,100 - 2,700 CFM
EHK4-15	26	30	15	2,100 - 2,700 CFM
EHK4-20	33	35	20	2,100 - 2,700 CFM
EHK4-25	41	45	25	2,100 - 2,700 CFM

MODEL AND HEAT KIT USAGE	MCA ¹ AT 575V	MOP ² (AMPS) AT 575V	ACTUAL kW & BTU AT 575V	RECOMMENDED AIRFLOW RANGE
DCC072***7B***	13	15	---	---
EHK7-10	15	20	10	2,100 - 2,700 CFM
EHK7-15	22	25	15	2,100 - 2,700 CFM
EHK7-20	28	30	20	2,100 - 2,700 CFM
EHK7-25	34	35	25	2,100 - 2,700 CFM

¹ Minimum Circuit Ampacity

² Maximum Overcurrent Protection Device

Note: All heaters have single-point entry kit

KW CORRECTION FACTOR FOR 3-PHASE UNITS

Supply Voltage	240	230	220	210
Correction Factor	1	0.92	0.84	0.77

KW CORRECTION FACTOR FOR 480V UNITS

ACTUAL VOLTAGE	460	440	430
CORRECTION FACTOR	0.92	0.84	0.8

For other voltage use $\text{voltage}^2 / 480^2$

KW CORRECTION FACTOR FOR 575V UNITS

SUPPLY VOLTAGE	560	550	540
CORRECTION FACTOR	0.95	0.91	0.88

Multiply rated kW by correction factor to get actual kW.

HEATER SIZE	MINIMUM CFM
10	2,100
15	2,100
20	2,100
25	2,100

MODEL AND HEAT KIT USAGE	MCA ¹ AT 208 / 240V	MOP ² (AMPS) AT 208 / 240V	ACTUAL kW & BTU AT 240V	RECOMMENDED AIRFLOW RANGE
DCC072***3V***	30.0	45	0	---
EHK3-10	37.6	45	10	2,100 - 2,700 CFM
EHK3-15	52.6	60	15	2,100 - 2,700 CFM
EHK3-20	67.6	70	20	2,100 - 2,700 CFM
EHK3-25	82.7	90	25	2,100 - 2,700 CFM

MODEL AND HEAT KIT USAGE	MCA ¹ AT 480V	MOP ² (AMPS) AT 480V	ACTUAL kW & BTU AT 480V	RECOMMENDED AIRFLOW RANGE
DCC072***4V***	14.4	20	0	---
EHK4-10	18.7	20	10	2,100 - 2,700 CFM
EHK4-15	26.2	30	15	2,100 - 2,700 CFM
EHK4-20	33.7	35	20	2,100 - 2,700 CFM
EHK4-25	41.2	45	25	2,100 - 2,700 CFM

MODEL AND HEAT KIT USAGE	MCA ¹ AT 575V	MOP ² (AMPS) AT 575V	ACTUAL kW & BTU AT 575V	RECOMMENDED AIRFLOW RANGE
DCC072***7V***	10.9	15	0	---
EHK7-10	15.6	20	10	2,100 - 2,700 CFM
EHK7-15	21.8	25	15	2,100 - 2,700 CFM
EHK7-20	28.1	30	20	2,100 - 2,700 CFM
EHK7-25	34.4	35	25	2,100 - 2,700 CFM

¹ Minimum Circuit Ampacity

² Maximum Overcurrent Protection Device

Note: All heaters have single-point entry kit

KW CORRECTION FACTOR FOR 3-PHASE UNITS

Supply Voltage	240	230	220	210
Correction Factor	1	0.92	0.84	0.77

KW CORRECTION FACTOR FOR 480V UNITS

ACTUAL VOLTAGE	460	440	430
CORRECTION FACTOR	0.92	0.84	0.8

For other voltage use $\text{voltage}^2 / 480^2$

KW CORRECTION FACTOR FOR 575V UNITS

SUPPLY VOLTAGE	560	550	540
CORRECTION FACTOR	0.95	0.91	0.88

Multiply rated kW by correction factor to get actual kW.

HEATER SIZE	MINIMUM CFM
10	2,100
15	2,100
20	2,100
25	2,100

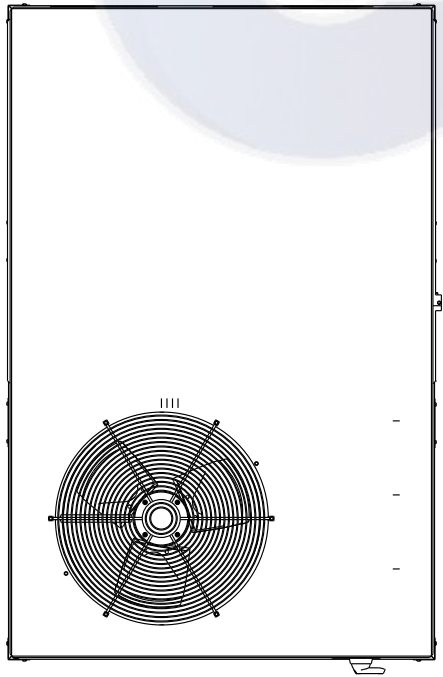

MODEL TONNAGES	"A"	"B"	"C"
3 TON COMMERCIAL GAS, HT PUMP, AIR CONDITIONER	38.840	16.555	26.055
4 TON COMMERCIAL GAS, HT PUMP, AIR CONDITIONER	38.840	16.555	26.055
5 TON COMMERCIAL GAS, HT PUMP, AIR CONDITIONER	38.840	16.555	26.055
6 TON COMMERCIAL GAS, HT PUMP, AIR CONDITIONER	42.840	20.555	30.055

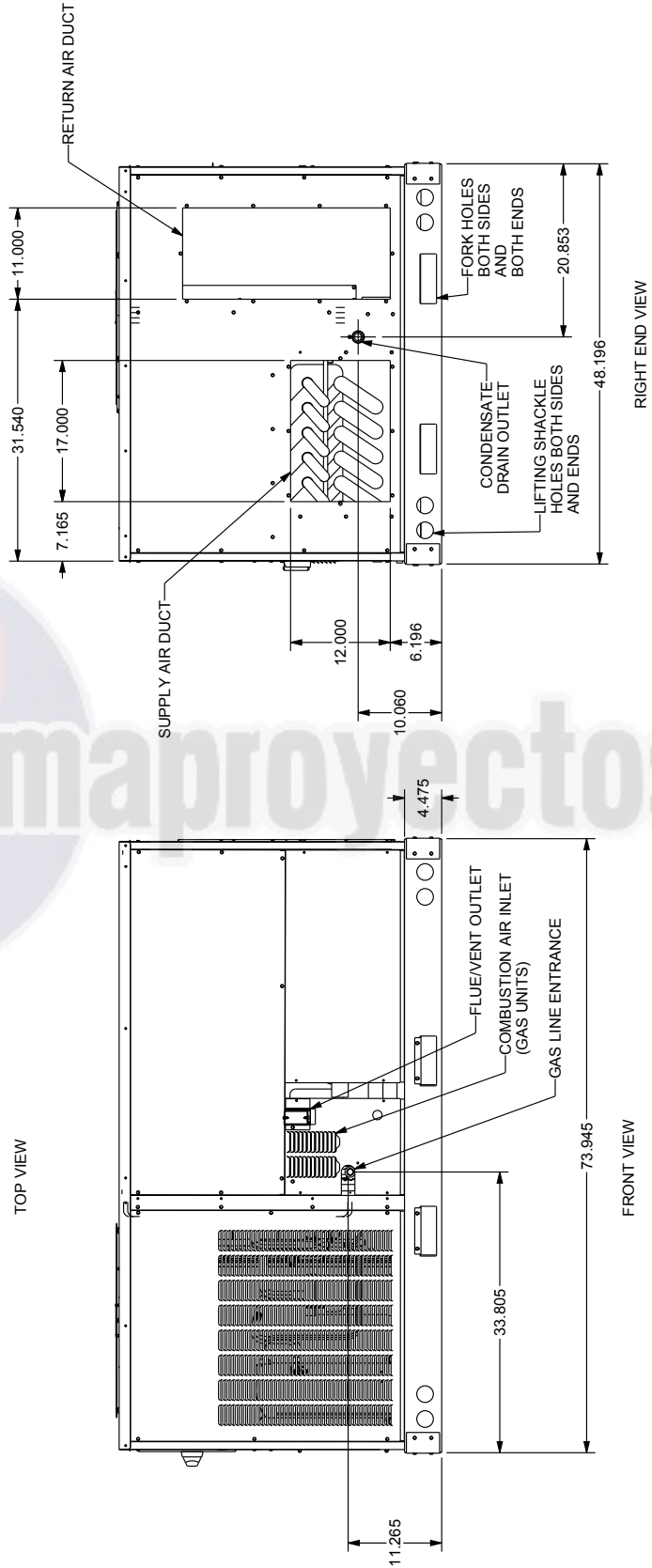

DC*036-072
3 THRU 6 TON COMMERCIAL

ALL DIMENSIONS GIVEN ARE IN INCHES
ALL DIMENSIONS AND SPECIFICATIONS ARE SUBJECT TO CHANGE WITHOUT NOTICE

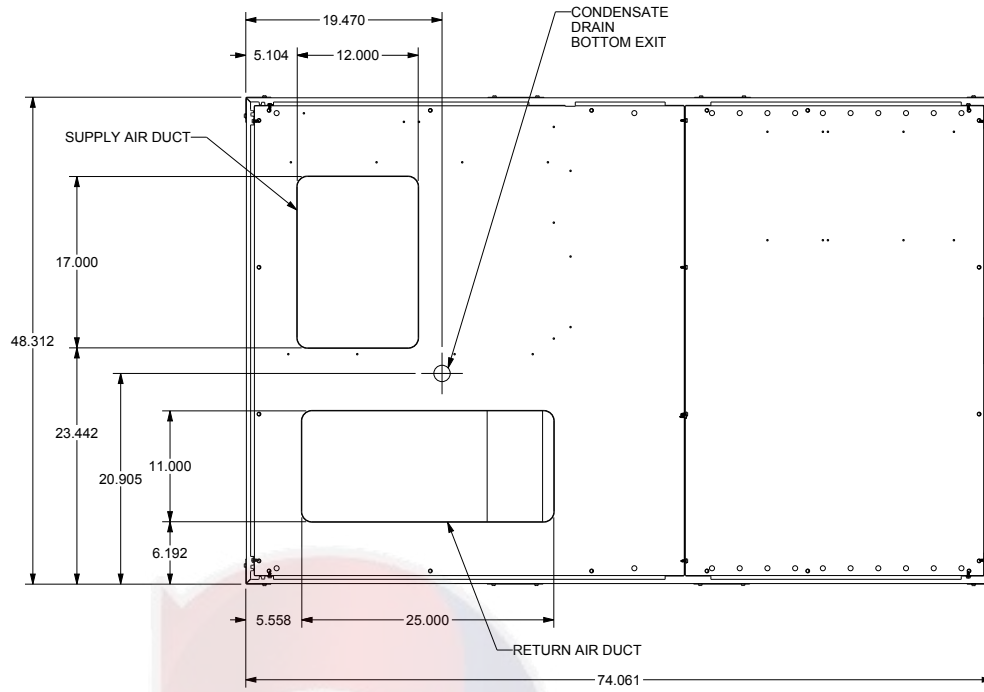

BASE PAN VIEW
(VIEWED FROM TOP)

MODEL TONNAGES	"A"	"B"	"C"
3 TON COMMERCIAL GAS, HT PUMP, AIR CONDITIONER	38.840	16.555	26.055
4 TON COMMERCIAL GAS, HT PUMP, AIR CONDITIONER	38.840	16.555	26.055
5 TON COMMERCIAL GAS, HT PUMP, AIR CONDITIONER	38.840	16.555	26.055
6 TON COMMERCIAL GAS, HT PUMP, AIR CONDITIONER	42.840	20.555	30.055

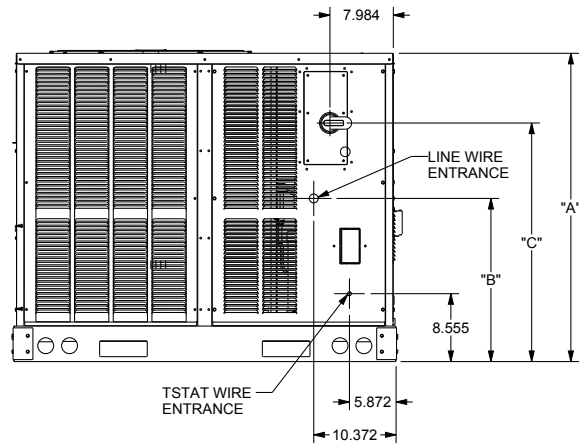

LEFT END VIEW

UNIT CLEARANCES

Maintain an adequate clearance around the unit for safety, service, maintenance, and proper unit operation. Leave a total clearance of 75" on the main control panel side of the unit for possible removal of fan shaft, coil, electric heat, and gas furnace. Leave a clearance of 48" on all other sides of the unit for possible compressor removal or service access, and to ensure proper ventilation and condenser airflow. Do not install the unit beneath any obstruction. Install the unit away from all building exhausts to inhibit ingestion of exhaust air into the unit's fresh-air intake.

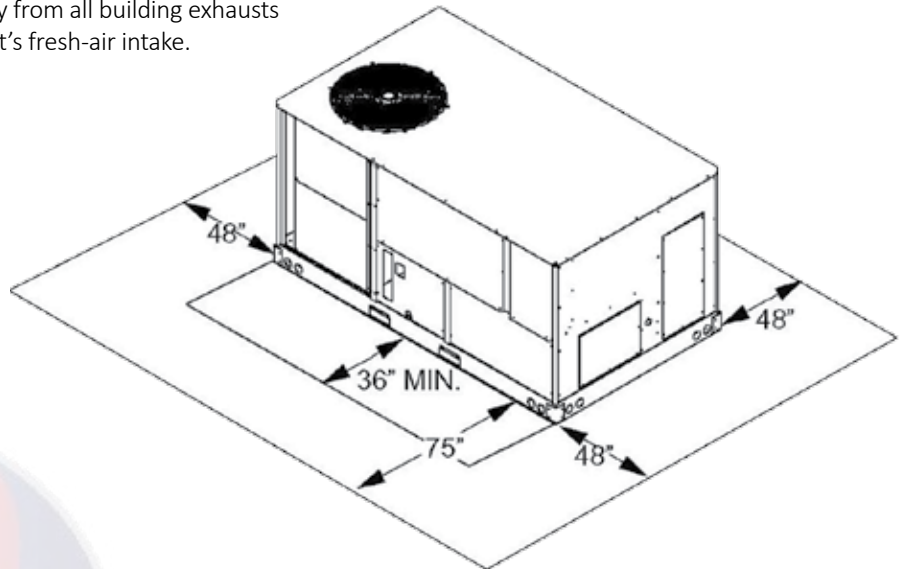

ELECTRICAL ENTRANCE LOCATIONS

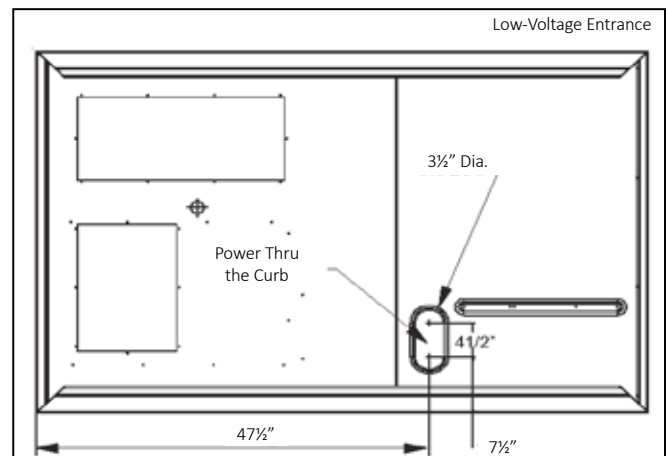
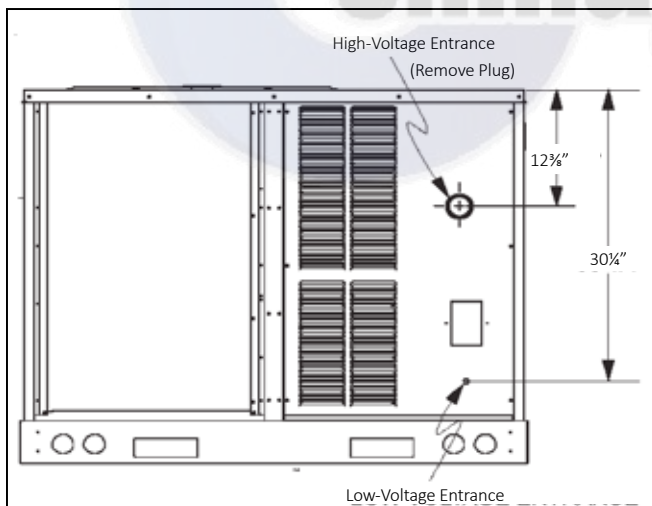

Provisions for forks have been included in the unit base frame. No other fork locations are approved.

- Unit must be lifted by the four lifting holes located at the base frame corners.
- Lifting cables should be attached to the unit with shackles.
- The distance between the crane hook and the top of the unit must not be less than 60”.
- Two spreader bars must span over the unit to prevent damage to the cabinet by the lift cables. Spreader bars must be of sufficient length so that cables do not come in contact with the unit during transport. Remove wood struts mounted beneath unit base frame before setting unit on roof curb. These struts are intended to protect unit base frame from fork lift damage. To remove the struts, extract the sheet metal retainers and pull the struts through the base of the unit. Refer to rigging label on the unit.

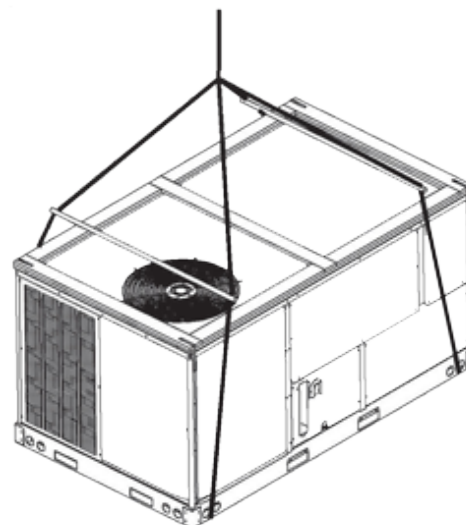

Important: If using bottom discharge with roof curb, duct-work should be attached to the curb prior to installing the unit. Duct-work dimensions are shown in Roof Curb Installation Instructions Manual.

Refer to the Roof Curb Installation Instructions for proper curb installation. Curbing must be installed in compliance with the National Roofing Contractors Association Manual.

Lower unit carefully onto roof mounting curb. While rigging the unit, the center of gravity will cause the condenser end to be lower than the supply air end.

Bring condenser end of unit into alignment with the curb. With condenser end of the unit resting on curb member and using curb as a fulcrum, lower opposite end of the unit until entire unit is seated on the curb. When a rectangular cantilever curb is used, take care to center the unit. Check for proper alignment and orientation of supply and return openings with duct.

To assist in determining rigging requirements, unit weights are shown below.

CORNER & CENTER-OF-GRAVITY LOCATIONS

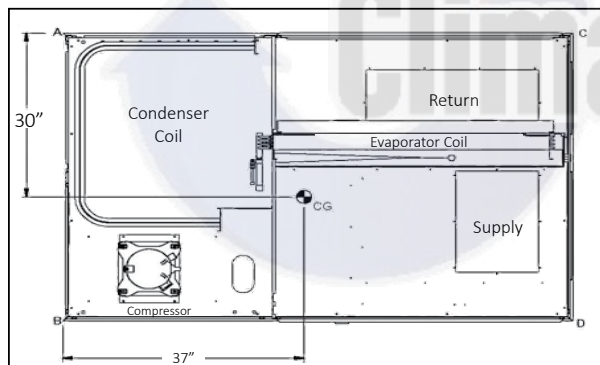

UNIT WEIGHTS	3-TON WEIGHTS	4-TON WEIGHTS	5-TON WEIGHTS	6-TON WEIGHTS
Corner Weight (A)	115	125	135	150
Corner Weight (B)	150	155	165	190
Corner Weight (C)	105	110	120	130
Corner Weight (D)	130	145	160	170
Unit Shipping Weight	525	560	605	665
Unit Operating Weight	500	535	580	640

Note: Weights are calculated without accessories installed.

Curb installations must comply with local codes and should follow the established guidelines of the National Roofing Contractors Association.

Proper unit installation requires that the roof curb be firmly and permanently attached to the roof structure. Check for adequate fastening method prior to setting the unit on the curb.

Full perimeter roof curbs are available from the factory and are shipped unassembled. The installing contractor is responsible for field assembly, squaring, leveling, and mounting on the roof structure. All required hardware necessary for the assembly of the sheet metal curb is included in the curb accessory package.

- Determine sufficient structural support before locating and mounting the curb and package unit.
- Duct-work must be constructed using industry guidelines. The duct-work must be placed into the roof curb before mounting the package unit. Our full perimeter curbs include duct connection frames to be assembled with the curb. Cantilevered-type curbs are not available from the factory.
- Contractor furnishes curb insulation, cant strips, flashing, and general roofing material.
- Support curbs on parallel sides with roof members. To prevent damage to the unit, the roof members cannot penetrate supply and return duct openings.

Note: The unit and curb accessories are designed to allow Down Shot duct installation before unit placement. Duct installation after unit placement is not recommended.

See the manual shipped with the roof curb for assembly and installation instructions.

WIRING DIAGRAM — DCC 3 THROUGH 4 TONS (230V, THREE PHASE, DIRECT DRIVE)

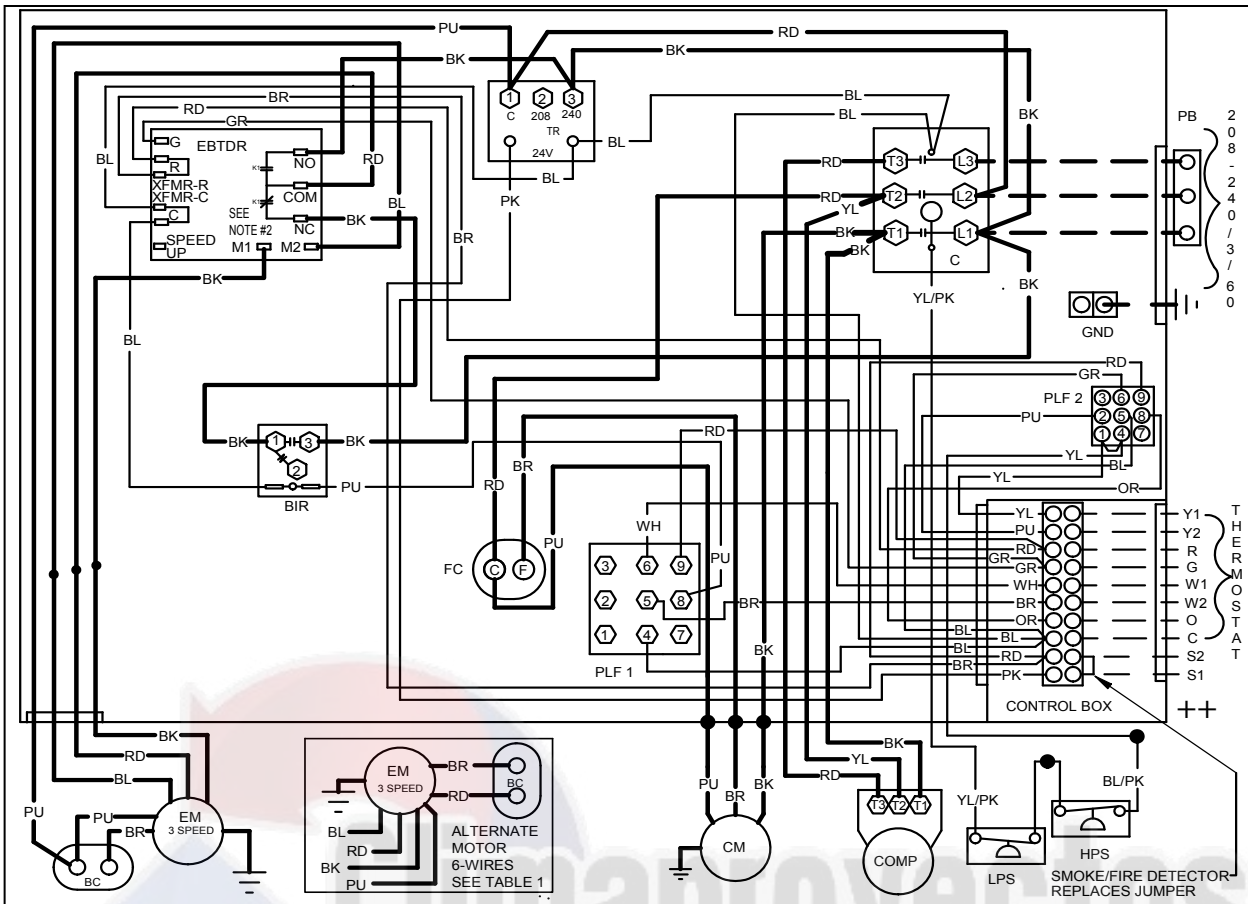

WARNING
High Voltage: Disconnect all power before servicing or installing this unit. Multiple power sources may be present. Failure to do so may cause property damage, personal injury, or death.

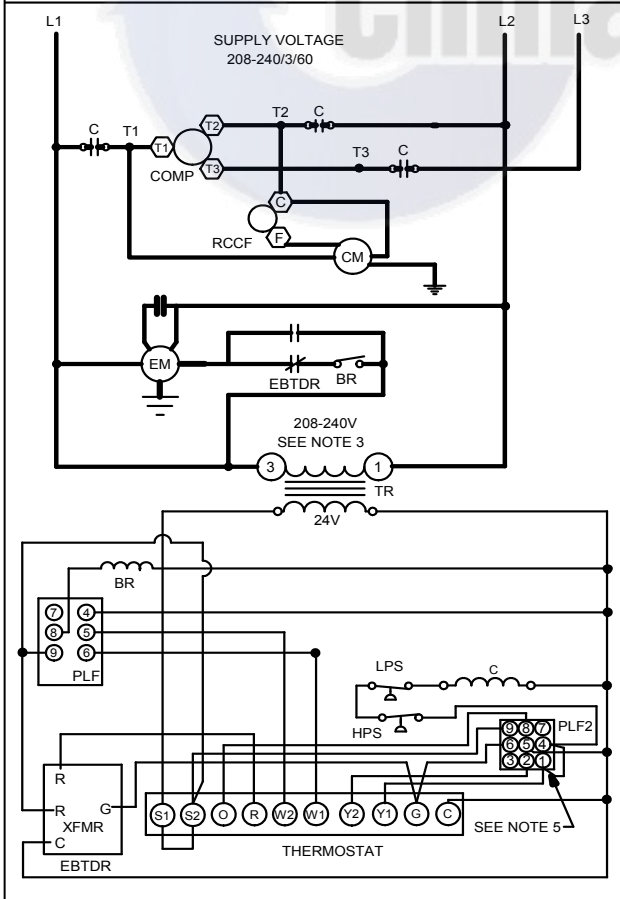

COMPONENT LEGEND

- BC BLOWER CAPACITOR
- BIR BLOWER INTERLOCK RELAY
- C CONTACTOR
- CM CONDENSER MOTOR
- COMP COMPRESSOR
- EM EVAPORATOR MOTOR
- GND EQUIPMENT GROUND
- HPS HIGH PRESSURE SWITCH
- LPS LOW PRESSURE SWITCH
- PLF FEMALE PLUG / CONNECTOR
- FC FAN CAPACITOR
- TB1 TERMINAL BLOCK (24V SIGNAL)
- TR TRANSFORMER

FACTORY WIRING

- LINE VOLTAGE
- LOW VOLTAGE
- OPTIONAL HIGH VOLTAGE

FIELD WIRING

- HIGH VOLTAGE
- LOW VOLTAGE

WIRE CODE

- BK BLACK
- BL BLUE
- BR BROWN
- GR GREEN
- OR ORANGE
- PK PINK
- PU PURPLE
- RD RED
- WH WHITE
- YL YELLOW
- BL/PK BLUE WITH PINK STRIP
- YL/PK YELLOW WITH PINK STRIP

NOTES:

- REPLACEMENT WIRE MUST BE SAME SIZE AND TYPE INSULATION AS ORIGINAL (AT LEAST 105°C) USE COPPER CONDUCTOR ONLY.
- TO CHANGE EVAPORATOR MOTOR SPEED MOVE M1 OR M2 WIRE TO COM TERMINAL ON EBTD R AND PLACE WIRE REMOVED FROM COM ON EMPTY M1 OR M2 TERMINAL.
- FOR 208 VOLT TRANSFORMER OPERATION MOVE BLACK WIRES FROM TERMINAL 3 TO TERMINAL 2 ON TRANSFORMER.
- USE COPPER CONDUCTORS ONLY ++ USE N.E.C. CLASS 2 WIRE
- ECONOMIZER PLUG LOCATED IN THE RETURN AIR COMPARTMENT. REMOVE MALE PLUG AND ATTACH FEMALE PLUG TO ECONOMIZER ACCESSORY.
- DIAGRAM SHOWS FACTORY SPEED TAP SETTINGS.

COLOR	TERMINATION
RD	COM (EBTD R)
BK	M1 (EBTD R)
BL	M2 (EBTD R)
PU	PIN 1 (24V XFMR)

RD	LOW
BL	MED
BK	HIGH

SEE UNIT RATING PLATE FOR TYPE AND SIZE OF OVER CURRENT PROTECTION

THERMOSTAT FIELD WIRING ++

NO ECONOMIZER

W1	— WH —	W
W2	— GR —	G
Y1	— RD —	R
Y2	— YL —	Y
C	— BL —	C
O	— OR —	O
S1	— — —	STAT

WITH ECONOMIZER OPTION

W1	— WH —	W
W2	— GR —	G
Y1	— RD —	R
Y2	— YL —	Y
C	— BL —	C
O	— OR —	O
S1	— — —	STAT

2 STAGE COOLING

W1	— WH —	W
W2	— GR —	G
Y1	— RD —	R
Y2	— YL —	Y
C	— BL —	C
O	— OR —	O
S1	— — —	STAT

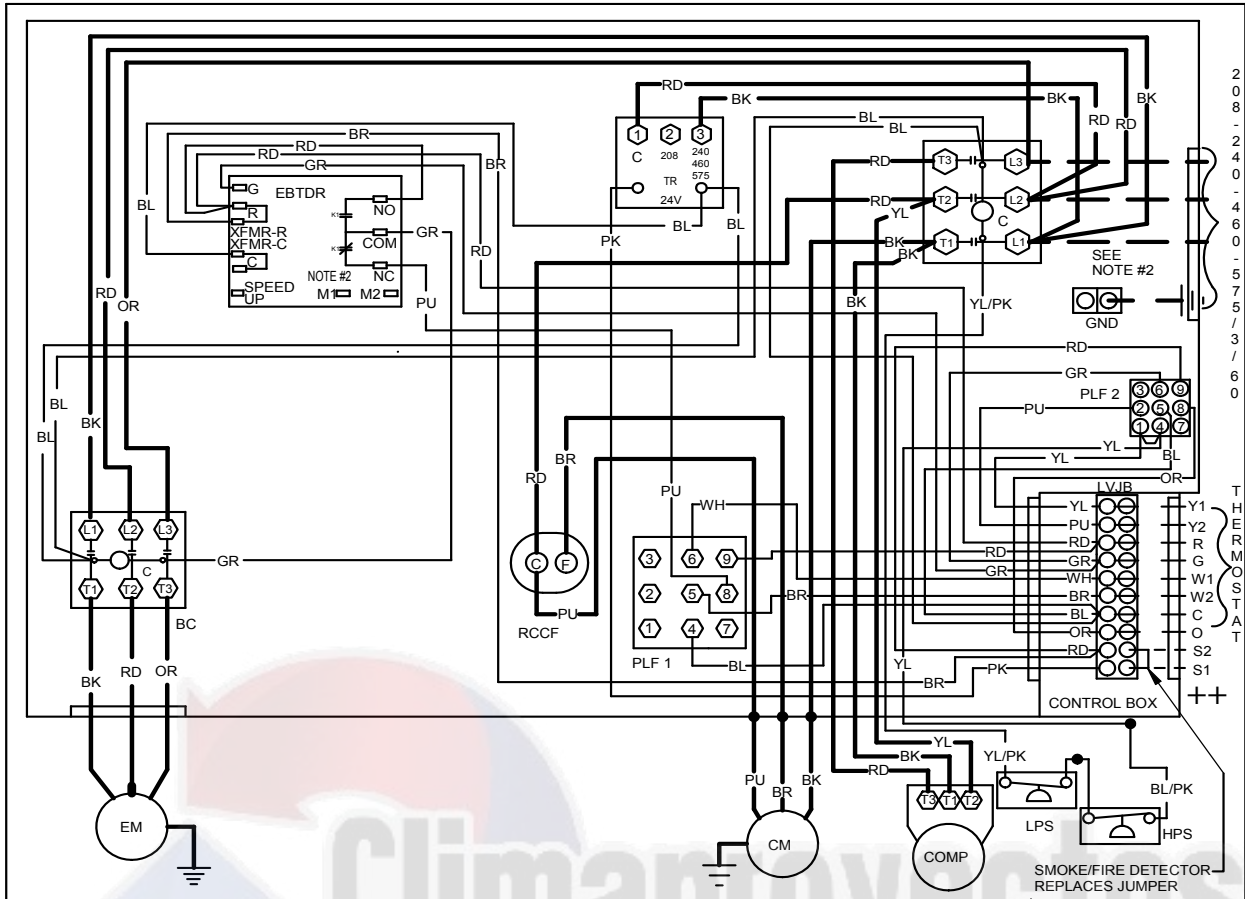

208-240-460-575-3-60

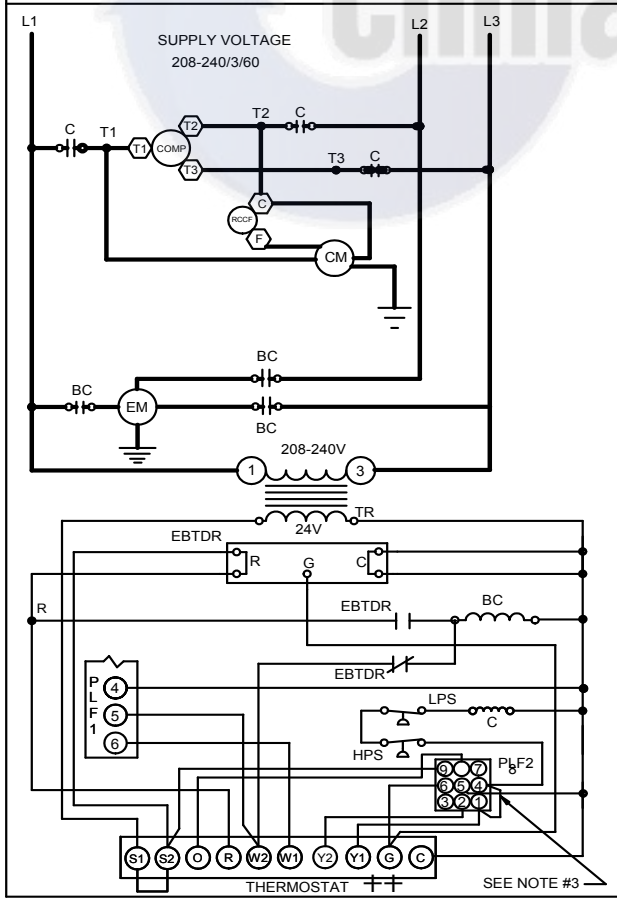

COMPONENT LEGEND

BC	BLOWER CONTACTOR
C	CONTACTOR
CM	CONDENSER MOTOR
CMR	CONDENSER MOTOR RELAY
COMP	COMPRESSOR
DC	DEFROST CONTROL
DFT	DEFROST THERMOSTAT
ECON	ECONOMIZER
EBTD	ELECTRONIC BLOWER TIME DELAY
EMR	EVAPORATOR MOTOR RELAY
R	RELAY
EM	EVAPORATOR MOTOR
FC	FAN CAPACITOR
GND	EQUIPMENT GROUND
HPS	HIGH PRESSURE SWITCH
HVDR	HIGH VOLTAGE DEFROST RELAY
LPS	LOW PRESSURE SWITCH
LVDR	LOW VOLTAGE DEFROST RELAY
LVJB	LOW VOLTAGE JUNCTION BOX
PB	POWER DISTRIBUTION BLOCK
PLF	FEMALE PLUG / CONNECTOR
RVC	REVERSING VALVE COIL
RCCF	RUN CAPACITOR FOR COMPRESSOR AND FAN
TB1	TERMINAL BLOCK (24V SIGNAL)
TR	TRANSFORMER

NOTES:

- REPLACEMENT WIRE MUST BE SAME SIZE AND TYPE INSULATION AS ORIGINAL (AT LEAST 105°C) USE COPPER CONDUCTOR ONLY.
- USE COPPER CONDUCTORS ONLY
- ECONOMIZER PLUG LOCATED IN THE RETURN AIR COMPARTMENT, REMOVE MALE PLUG, ATTACH FEMALE PLUG TO THE ECONOMIZER ACCESSORY.
- FOR 208 VOLT TRANSFORMER OPERATION MOVE BLACK WIRES FROM TERMINAL ③ TO TERMINAL ② ON TRANSFORMER.

SEE UNIT RATING PLATE FOR TYPE AND SIZE OF OVER CURRENT PROTECTION

FACTORY WIRING

— LINE VOLTAGE
— LOW VOLTAGE
- - - OPTIONAL HIGH VOLTAGE

FIELD WIRING

— HIGH VOLTAGE
- - - LOW VOLTAGE

WIRE CODE

BK BLACK
BL BLUE
BR BROWN
GR GREEN
OR ORANGE
PK PINK
PU PURPLE
RD RED
WH WHITE
YL YELLOW
BL/PK BLUE WITH PINK STRIP
YL/PK YELLOW WITH PINK STRIP

THERMOSTAT FIELD WIRING ++

NO ECONOMIZER

W	— WH —	W
G	— GR —	G
R	— RD —	R
Y	— YL —	Y
C	— BL —	C
O	— OR —	O
STAT	— —	STAT

WITH ECONOMIZER OPTION

W	— WH —	W
G	— GR —	G
R	— RD —	R
Y1	— YL —	Y1
Y2	— —	Y2
C	— BL —	C
O	— OR —	O
STAT	— —	STAT

2 STAGE COOLING

W	— WH —	W
G	— GR —	G
R	— RD —	R
Y1	— YL —	Y1
Y2	— —	Y2
C	— BL —	C
O	— OR —	O
STAT	— —	STAT

WARNING

High Voltage: Disconnect all power before servicing or installing this unit. Multiple power sources may be present. Failure to do so may cause property damage, personal injury, or death.

Wiring is subject to change. Always refer to the wiring diagram on the unit for the most up-to-date wiring.



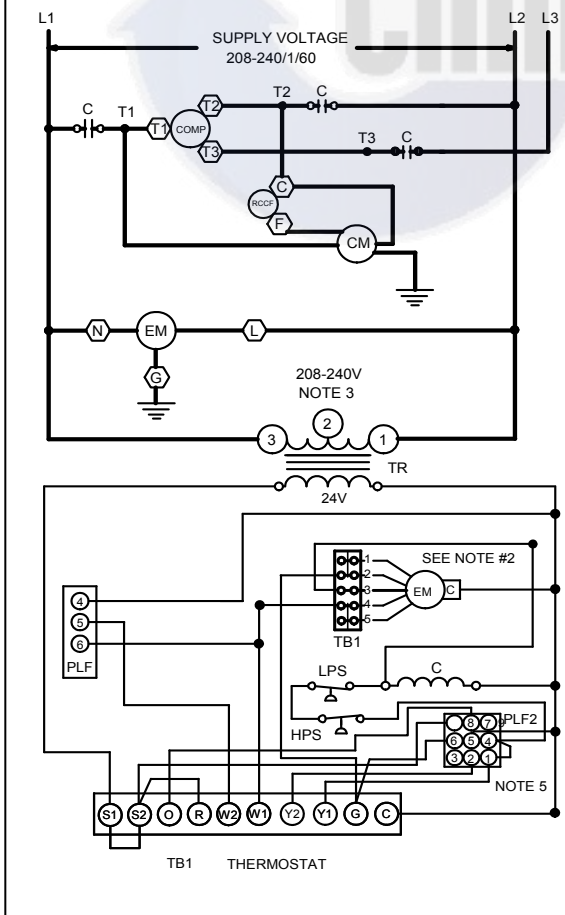
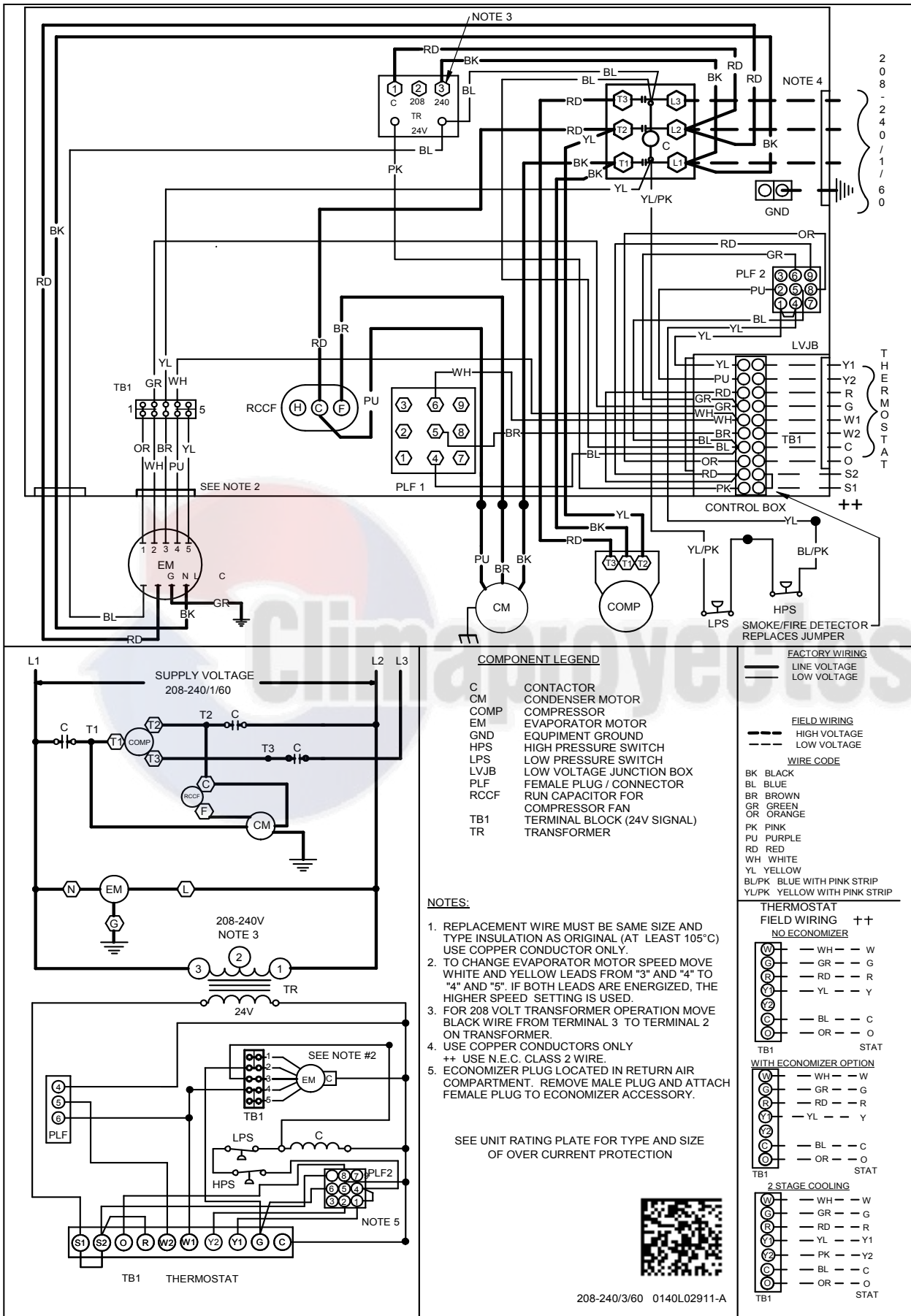

COMPONENT LEGEND

C CONTACTOR
 CM CONDENSER MOTOR
 COMP COMPRESSOR
 EM EVAPORATOR MOTOR
 GND EQUIPMENT GROUND
 HPS HIGH PRESSURE SWITCH
 LPS LOW PRESSURE SWITCH
 LVJB LOW VOLTAGE JUNCTION BOX
 PLF FEMALE PLUG / CONNECTOR
 RCCF RUN CAPACITOR FOR COMPRESSOR FAN
 TB1 TERMINAL BLOCK (24V SIGNAL)
 TR TRANSFORMER

NOTES:

- REPLACEMENT WIRE MUST BE SAME SIZE AND TYPE INSULATION AS ORIGINAL (AT LEAST 105°C) USE COPPER CONDUCTOR ONLY.
- TO CHANGE EVAPORATOR MOTOR SPEED MOVE WHITE AND YELLOW LEADS FROM "3" AND "4" TO "4" AND "5". IF BOTH LEADS ARE ENERGIZED, THE HIGHER SPEED SETTING IS USED.
- FOR 208 VOLT TRANSFORMER OPERATION MOVE BLACK WIRE FROM TERMINAL 3 TO TERMINAL 2 ON TRANSFORMER.
- USE COPPER CONDUCTORS ONLY
 ++ USE N.E.C. CLASS 2 WIRE.
- ECONOMIZER PLUG LOCATED IN RETURN AIR COMPARTMENT. REMOVE MALE PLUG AND ATTACH FEMALE PLUG TO ECONOMIZER ACCESSORY.

SEE UNIT RATING PLATE FOR TYPE AND SIZE OF OVER CURRENT PROTECTION



208-240/3/60 0140L02911-A

FACTORY WIRING
 — LINE VOLTAGE
 — LOW VOLTAGE

FIELD WIRING
 - - - HIGH VOLTAGE
 - - - LOW VOLTAGE

WIRE CODE

BK BLACK
 BL BLUE
 BR BROWN
 GR GREEN
 OR ORANGE
 PK PINK
 PU PURPLE
 RD RED
 WH WHITE
 YL YELLOW
 BL/PK BLUE WITH PINK STRIP
 YL/PK YELLOW WITH PINK STRIP

THERMOSTAT FIELD WIRING ++

NO ECONOMIZER

W	— WH —	W
R	— GR —	G
R	— RD —	R
O	— YL —	Y
C	— BL —	C
O	— OR —	O
STAT		

WITH ECONOMIZER OPTION

W	— WH —	W
R	— GR —	G
R	— RD —	R
O	— YL —	Y
C	— BL —	C
O	— OR —	O
STAT		

2 STAGE COOLING

W	— WH —	W
R	— GR —	G
R	— RD —	R
O	— YL —	Y1
Y2	— PK —	Y2
C	— BL —	C
O	— OR —	O
STAT		

High Voltage: Disconnect all power before servicing or installing this unit. Multiple power sources may be present. Failure to do so may cause property damage, personal injury, or death.

WARNING

Wiring is subject to change. Always refer to the wiring diagram on the unit for the most up-to-date wiring.

WIRING DIAGRAM — DCC CONTROLS DIAGRAM DCC072 - 2 SPEED (ALL VOLTAGES)

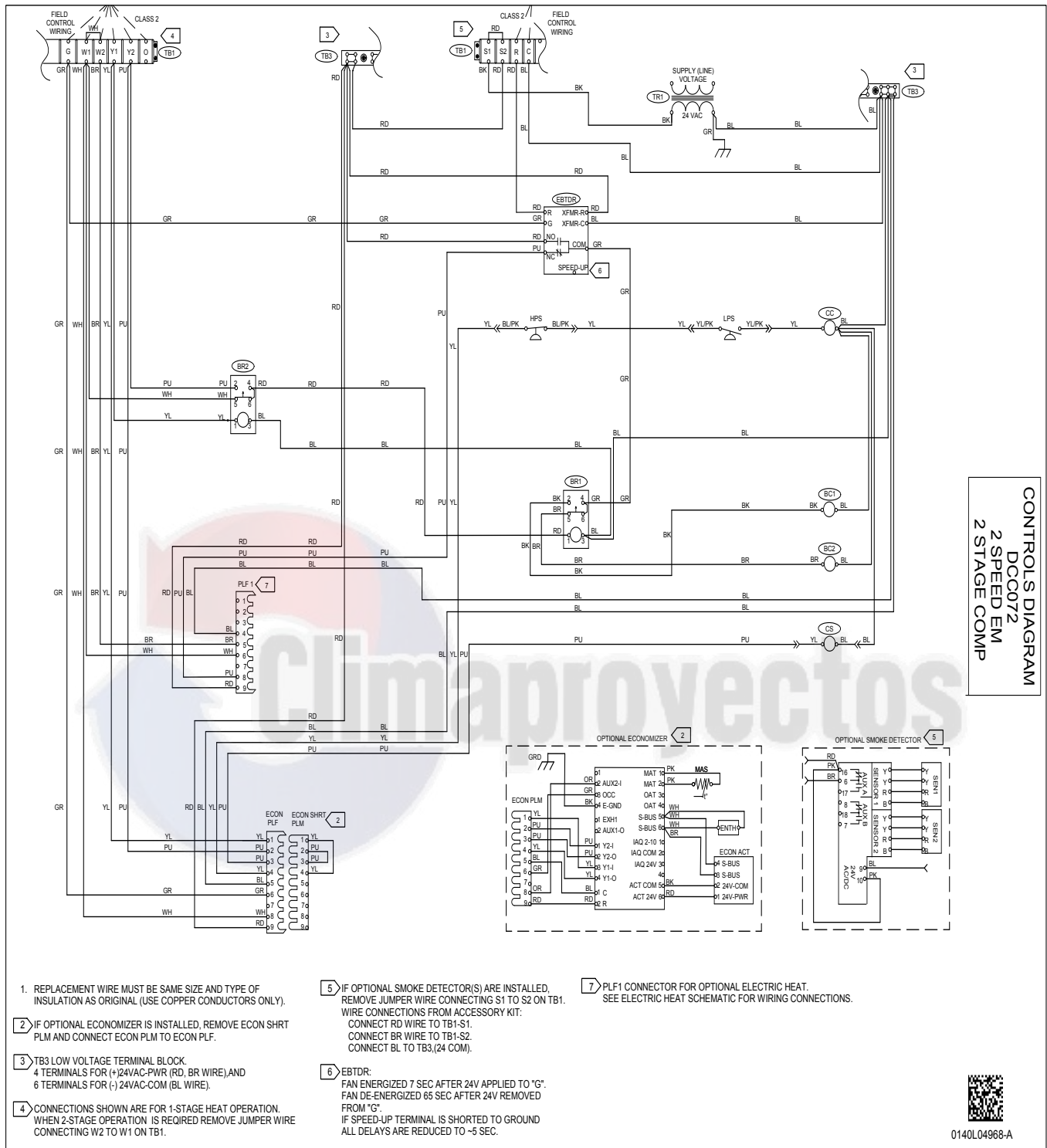

Wiring is subject to change. Always refer to the wiring diagram on the unit for the most up-to-date wiring.

<b style="font-size: 1.2em;">WARNING	<p>High Voltage: Disconnect all power before servicing or installing this unit. Multiple power sources may be present. Failure to do so may cause property damage, personal injury, or death.</p>	
--	--	--

WIRING DIAGRAM — DCC POWER DIAGRAM DCC072 - 2 SPEED (ALL VOLTAGES)

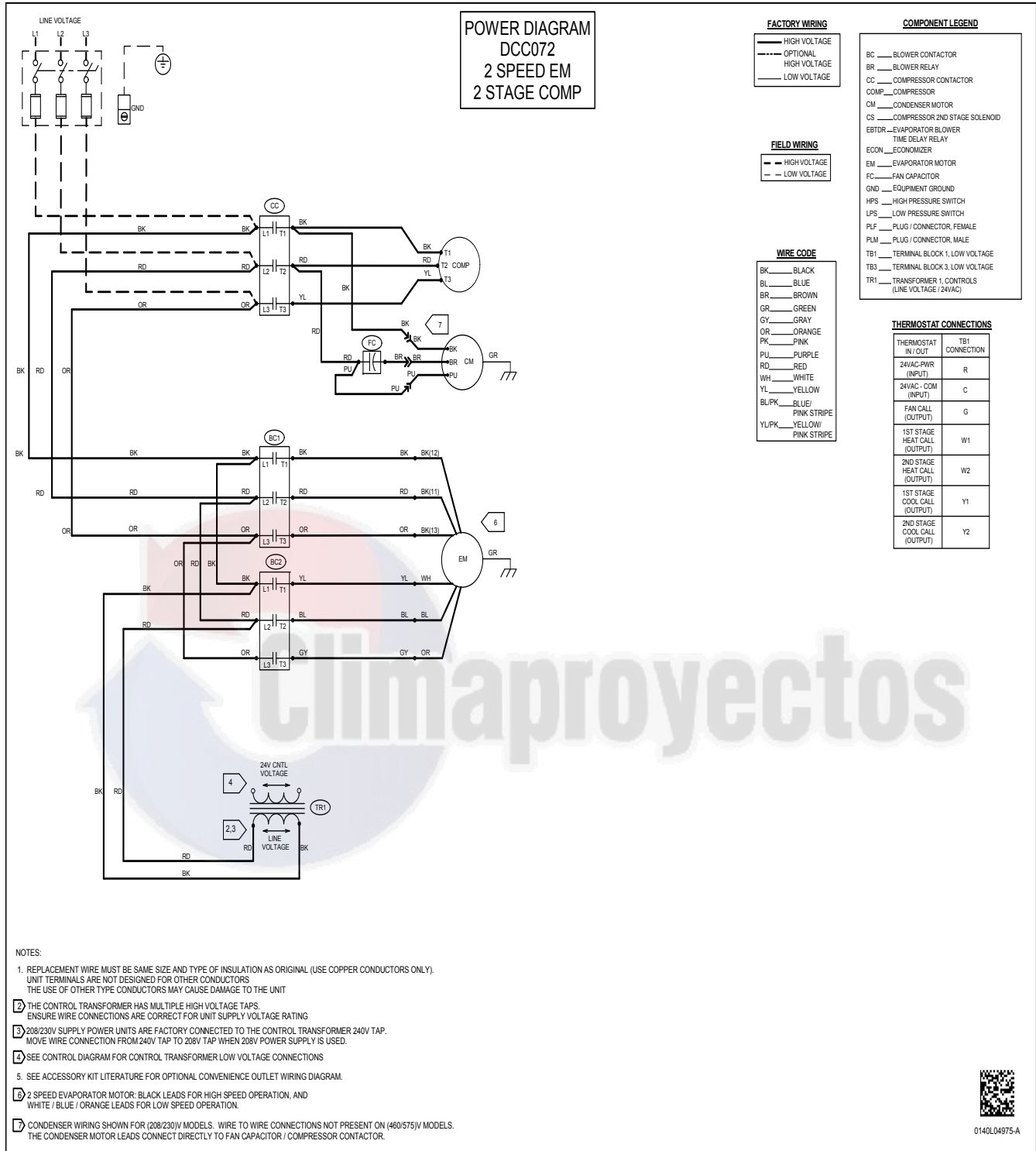

Wiring is subject to change. Always refer to the wiring diagram on the unit for the most up-to-date wiring.

WARNING

High Voltage: Disconnect all power before servicing or installing this unit. Multiple power sources may be present. Failure to do so may cause property damage, personal injury, or death.

DAIKIN MASTER ITEM #	DESCRIPTION	FITS MODEL SIZES	FIELD-INSTALLED	FACTORY-INSTALLED	OPERATING WEIGHT (LBS)
14CURB3672	14" Roof Curb	3-6 tons	√		86
D25FD3672	25% Manual Fresh Air Damper	3-6 tons	√		12
D25MFD3672	25% Motorized Fresh Air Damper	3-6 tons	√		16
DDNBBS3672	Burglar Bar Sleeves with Supply & Return	3-6 tons	√		30
CDK36	Concentric Duct Kit	3 tons	√		27
CDK4872	Concentric Duct Kit	4-6 tons	√		27
HAILGD03D	Condenser Coil Hail Guard	3-5 tons	√		19
HAILGD04D	Condenser Coil Hail Guard	6 tons	√		22
	Convenience Outlet: Non Powered	All Models		√	2
	Convenience Outlet: Powered	All Models		√	42
	Disconnect Switch	All Models		√	5
	Ultra Low-Leak Downflow Economizer ¹	3-6 tons		√	71
DDNECNJ3672B	Low-Leak Downflow Economizer ²	3-6 tons	√	√	77
DDNECNJ3672NR	Downflow Economizer ² w/o Barometric Relief	3-6 Tons	√		77
DDNSQRD3616	Downflow Square-to-Round Adapter (16" Round)	3 tons	√		45
DDNSQRD487218	Downflow Square-to-Round Adapter (18" Round)	4-6 tons	√		35
	Electric Heat Kits	All Models	√	√	21
HSKT036B ³	High-Static Kit (230/460v)	3 tons	√		41
HSKT036B-7 ³	High-Static Kit (575v)	3 tons	√		5
HSKT048B ³	High-Static Kit (230/460v)	4 tons	√		38
HSKT048B-7 ³	High-Static Kit (575v)	4 tons	√		27
HSKT060B ³	High-Static Kit (230/460v)	5 tons	√		38
HSKT060B-7 ³	High-Static Kit (575v)	5 tons	√		28
HSKT072B ³	High-Static Kit (230/460v)	6 tons	√		38
HSKT072B-7 ³	High-Static Kit (575v)	6 tons	√		15
DHZECNJ3672	Horizontal Economizer	3-6 tons	√		70
GHRC-1	Hurricane Restraint Clips	All Models	√		2
DBRD3672	Barometric Relief Damper	3-6 tons	√		15
LAKT01	Low-Ambient Kit	3-6 tons	√	√	2
DPE36722	Downflow Power Exhaust (208/230 Volt)	3-6 tons	√		55
DPE36724	Downflow Power Exhaust (460 Volt)	3-6 tons	√		55
DPE36727	Downflow Power Exhaust (575v)	3-6 tons	√		55
	Smoke Detector	All Models		√	11
	Hinged Panels	3-6 tons		√	10

¹ Please contact RRS Rooftop Systems directly if Power Exhaust is required.

² Please use part number DPE36722 / DPE36724 / DPE36727 if Power Exhaust is required.

³ HSKT High-Static Kits are for use with standard single-speed belt-drive units only.

Note: Where multiple variations are available, the heaviest combination is listed.

