

Engineering Data

ED 19043-1

Group: **WSHP**

Document PN: **ED 19043-1**

Date: **October 2016**

Sound Power Ratings for Enfinity™ Horizontal Ceiling Water Source Heat Pump Products

Introduction

An exceptional level of Indoor Environmental Quality (IEQ) and personal comfort should be goals for all HVAC designs. Sound quality and the associated sound levels are a few of the many key parameters in measuring personal comfort. To deliver this type of comfort, acoustic consultants may have to be involved for complex and acoustically sensitive applications such as performing arts centers, theaters, and large gathering spaces. However, it is the HVAC designer and the project architect working together who are most likely tasked with creating a comfortable acoustic environment. Given the potentially significant noise contributions from the HVAC system, the HVAC designer must be equipped with specialized tools to help facilitate important acoustic design decisions.

Daikin has developed several tools to assist the design team in evaluating the acoustic performance of HVAC systems. The Application Guide – HVAC Acoustic Fundamentals¹ is a detailed technical reference manual with comprehensive acoustic fundamentals combined with typical HVAC system acoustic analysis guidance. When used in conjunction with Daikin's Acoustic Analyzer™ software and published sound power data from the manufacturer, the design team can estimate the room sound levels. These tools can help to estimate the affect of the HVAC equipment sound levels both in the space and outside of the building. The information generated by the Acoustic Analyzer™ software can help determine if the resulting room sound levels can meet the specifications or if further acoustic attenuation, alternative HVAC equipment or building modifications are necessary.

¹ Daikin Applied Application Guide – HVAC Acoustic Fundamentals, Catalog
AG 31-010

System Analysis

Three types of acoustic analyses can be performed with Daikin's Acoustic Analyzer™ software. These include Outdoor Sound, Zoned Comfort Systems and Central Systems. This Engineering Document focuses on the Enfinity Horizontal Water Source Heat Pump sound power data and the resulting indoor sound levels based on a zoned comfort system. However, the Acoustic Analyzer™ software can be used to evaluate the acoustic performance of the following other system types:

- **Outdoor Sound** – this is used to estimate sound levels at the property line or at an adjacent building. The sound source is typically an air-cooled chiller, rooftop unit or cooling tower.
- **Zoned (Decentralized) Comfort Systems** – this is used to estimate sound levels of indoor equipment that resides in or near the occupied space. These include systems that reside in the occupied space (i.e. console water source heat pumps) and units that are ducted away from or above the occupied space (i.e. horizontal and vertical water source heat pumps). The Acoustic Analyzer™ software takes the room effect, duct breakout, return and discharge air noise, and radiated sound pathways into consideration.
- **Central Systems** – this is used to estimate sound levels from HVAC equipment that serve multiple spaces such as a chilled water air handler with multiple VAV boxes in several zones. This analysis tends to be based on larger equipment with greater sound power levels. The Acoustic Analyzer™ divides central systems into two categories; “Large” for applications with open office spaces and “Defined” for all other



applications. The Acoustic Analyzer™ can perform several acoustic evaluations of a Central System, including:

- Supply and return duct sound. A special feature allows the mechanical room to be included in the return air path. This is specifically meant for vertical self-contained systems that often use the mechanical room as the return air plenum
- Diffuser sound
- Terminal unit radiated sound
- Sound transmitted through a wall
- Sound breakout from any node on the supply or return duct

The “Zoned (Decentralized) Comfort Systems” analysis should be the basis for evaluating the occupied space sound levels for a water source heat pump system.

Analysis Summary and Output Reports

To assist the design team in making decisions regarding the proposed system, the Acoustic Analyzer™ provides an easy to follow summary of the calculated results. The summary report provides the basic acoustic analysis information including the room effect calculations, attenuation guidance, and a plot of the resulting sound criteria.

The sound criteria can be determined based on Noise Criteria (NC), Room Criteria (RC) or Noise Rating (NR). An example of the NC evaluation and report is shown in Figure 1.

Figure 1: Examples of the NC Evaluation and Report

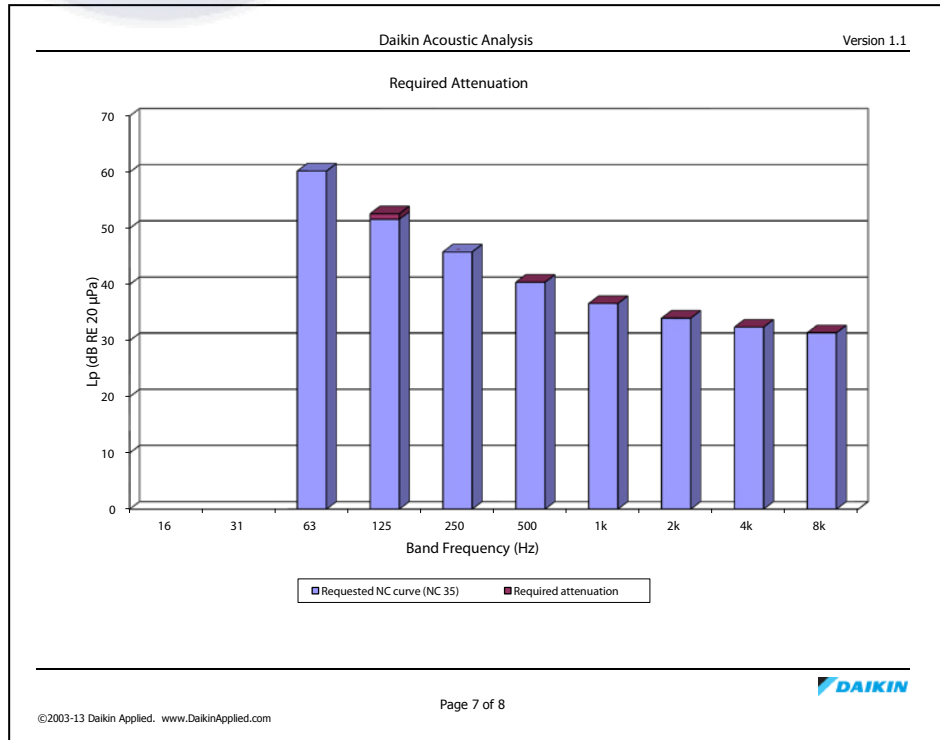
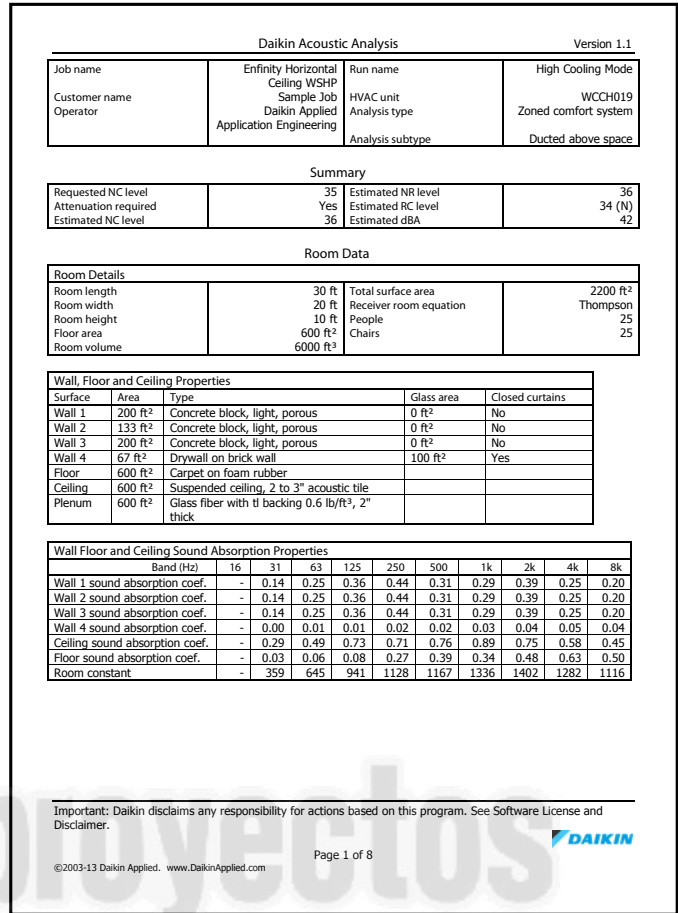

Getting a Copy

For a demo of the Acoustic Analyzer™ software, please visit www.DaikinApplied.com and follow these simple steps:

- Click on the Design Tools link from the left side bar
- Click on the Software link from the drop down list
- On the Software page, click on the Acoustic Analyzer™ Software Demo link¹

To order a copy of the software, simply contact your local Daikin sales representative. Use the Sales Locator link on the Software page to find the closest Daikin sales Representative near you.

¹ Daikin Applied Application Guide – HVAC Acoustic Fundamentals, Catalog AG 31-010

Daikin Acoustic Analysis Version 1.1

Acoustic Performance
Summary

Summary of Lp Due to All Paths										
Band (Hz)	16	31	63	125	250	500	1k	2k	4k	8k
Supply duct Lp	-	-	-	28	21	6	0	0	1	1
Break out Lp	-	-	-	29	15	0	0	0	0	0
Return duct Lp	-	-	-	38	32	22	4	8	13	9
Diffuser Lp	-	-	40	32	37	34	36	27	13	10
Radiated Lp	-	-	-	52	44	34	12	14	1	6
Total Lp at Room Center, Receiver Measuring Height										
Sound meter Lp	-	-	-	52	45	37	36	27	16	14
Requested NC curve (NC 35)	-	-	60	52	46	40	37	34	32	31
Required attenuation	-	-	-	1	0	0	0	0	0	0

Page 5 of 8

©2003-13 Daikin Applied. www.DaikinApplied.com

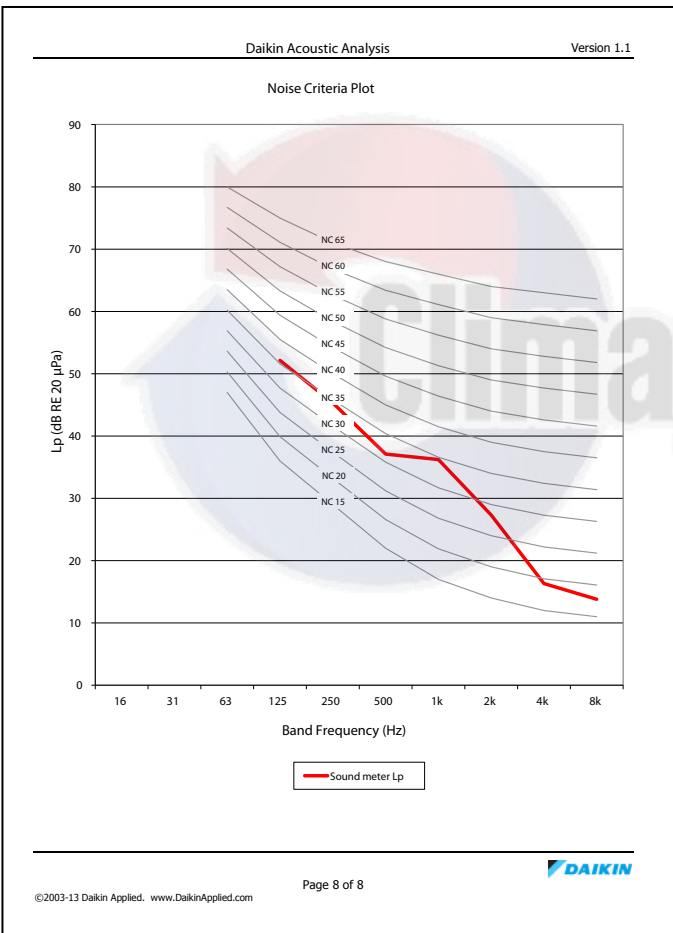

Sound Power Fundamentals

What is the Difference between Sound and Noise?

Sound pressure is what causes our ear drums to vibrate and what is captured by a microphone to make an audio recording. “Noise” however, is what many people consider an annoyance, a distraction or even a painful reminder of excessive sound pressure. Noise, simply put, can cause an undesirable affect if not properly managed. However, this noise can create a subtle background sound level that can improve the indoor environmental quality if properly designed into the building.

In HVAC systems, noise can lead to uncomfortable indoor environmental quality. However, this same “noise” if properly controlled or attenuated can enhance the comfort of a building by creating subtle background noise. While other noises both inside and outside of the occupied space can affect the indoor noise levels, the HVAC system designer should strive to ensure that the noise levels produced by the HVAC system are appropriate for the space. To do so, the sound pressure must be determined.

What is Sound Pressure?

Sound pressure is a measure of the dynamic pressure that causes local pressure fluctuations in the air molecules. These fluctuations can be measured in Pascals (symbol is Pa) or when expressed in decibels (symbol is dB) the term is known as Sound Pressure Level. This pressure is what is measured by a microphone or perceived by our ear drums.

Sound pressure is very much dependent on the acoustic environment where it is measured or heard. As an example, a room with hard surfaces such as hardwood floors, gypsum wall boards and hard ceilings will have a significantly different measured sound pressure from a room with “soft” absorbent surfaces such as carpets, wall hangings and acoustic tile ceilings. Other factors include the effects of reflective surfaces, distance to the receiver or microphone, room surface treatments, the quantity and location of sound absorbing materials, physical barriers, and the influence of other sound sources in the space. All of these influences should be considered when assessing the acoustic performance of an HVAC system in a particular occupied space.

What is Sound Power?

Sound Power, P_{ac} is a measure of the sonic energy over a unit of time for a given sound source emitted by the source in all directions. This represents the acoustic property of the sound source expressed in watts. Sound power expressed in decibels (dB) is known the Sound Power Level, L_w expressed in a very low base level of energy given as 0.000000000001 or 10^{-12} W.

Most important is that sound power is the acoustic “signature” of the particular sound source. This signature is totally independent of any affect that a room might have on the resulting sound pressure measured in that space.

Sound power is determined in a controlled acoustic environment under tightly controlled laboratory conditions. These laboratories can be reverberant or anechoic rooms with sophisticated sound intensity measurement instrumentation. Sound power can vary dramatically under different operating conditions such as fan speed, static pressure, compressor loading and thermal conditions under which the HVAC system is operating. For this reason, sound power is determined in accordance with ARI Sound Standards to ensure uniformity between different manufactures of similar equipment types. All reputable HVAC manufacturers should publish sound power data for their equipment to assist the system designer in assessing the resulting acoustic affect for a given application.

Table 1 provides a comparison between several different sound sources.

Table 1: Sound Power Sources

Situation and Sound Source	Sound Power P_{ac} watts	Sound Power Level L_w dB re 10^{-12} W
Rocket engine	1,000,000 W	180 dB
Turbojet engine	10,000 W	160 dB
Siren	1,000 W	150 dB
Heavy truck engine or loudspeaker rock concert	100 W	140 dB
Machine gun	10 W	130 dB
Jackhammer	1 W	120 dB
Excavator, trumpet	0.3 W	115 dB
Chain saw	0.1 W	110 dB
Helicopter	0.01 W	100 dB
Loud speech	0.001 W	90 dB
Usual talking	10^{-5} W	70 dB
Refrigerator	10^{-7} W	50 dB

What is the difference between Sound Pressure and Sound Power?

Understanding the difference between sound pressure and sound power is very important when assessing the acoustical performance of the HVAC system. As mentioned above, sound power is the acoustic signature of the equipment, while sound pressure is the resulting measure of what your ear will hear. From the sound power data provided by the manufacturer, an acoustic analysis can be performed using software tools such as the Acoustic Analyzer™. Sound power data is entered into the acoustic analysis tool along with the room properties to calculate the resulting room sound pressure level.

Noise Criteria (NC) and Room Criteria (RC)

In order to understand the potential effect of HVAC-related sound on the building occupants, several criteria have been established to rate or measure the sound to determine its acceptability. To do so, an estimate of both the perceived loudness and the sound quality of the noise should be understood. By using the calculated sound pressure level, the Noise Criteria (NC) or Room Criteria (RC) can be used to determine its acceptability depending on the nature of the application and the desired effect. In general, NC is a single-number rating that is somewhat sensitive to the relative loudness and speech interference properties of a given sound spectrum². The RC method is a family of criterion curves and a rating procedure that assesses background noises

in spaces, both on the basis of its effect on speech, and on subjective sound quality³. Both criteria have advantages and disadvantages when attempting to characterize HVAC system generated background noise. The HVAC designer should become fully knowledgeable of the assessment criteria and desired outcome before drawing conclusions regarding the suitability of any solution or a given application. In some cases, seeking the advice of a professional acoustical consultant may be necessary to achieve the desired acoustic performance for the application.

Sound Rating Standards

Standard AHRI 260-2001 - Sound Rating of Ducted Air Moving and Conditioning Equipment

Several AHRI standards have been developed to ensure that HVAC manufacturers, who choose to follow the standard, can provide sound power data in accordance documented requirements and recognized industry procedures. The purpose of Standard AHRI 260-2001 is to establish a method of sound rating the indoor portions of ducted air moving and conditioning equipment and to provide definitions; requirements for acquiring mapped sound data; Sound Power Level calculations and ratings; minimum data requirements for published sound ratings; and conformance conditions⁴. As a result, Daikin can provide industry recognized sound power levels to assist HVAC designers in assessing the acoustic performance of the HVAC system.

AHRI 260-2001 has been used to establish the radiated sound power levels for a horizontal or vertical water source heat pump for several different return and discharge air configurations. One of the most common configurations for water source heat pumps is known as the “ducted discharge”. This best represents a typical furred-in application similar to a residential condo, college dormitory or high-rise hotel installation with the return air register located in an adjoining space and where the supply air is ducted into the occupied space. The typical free inlet test setup for ducted discharge arrangements is shown in [Figure 2](#).

Figure 2: Typical Free Inlet Test Set-up for “Ducted Discharge” Applications

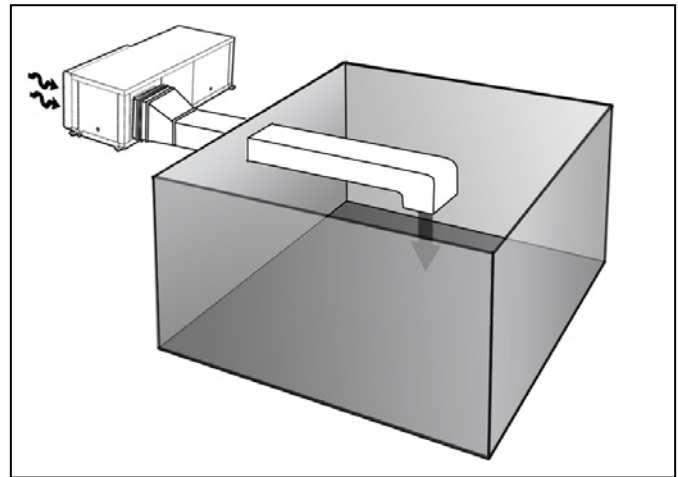

Another common configuration has the water source heat pump unit located in a mechanical closet adjacent to the occupied space. A measure of the sound levels inside the mechanical space can be best determined using the free inlet combined with the casing radiated configuration. The test setup for this is shown in [Figure 3](#).

Figure 3: Typical Free Inlet Combined with Casing Radiated Test Set-up

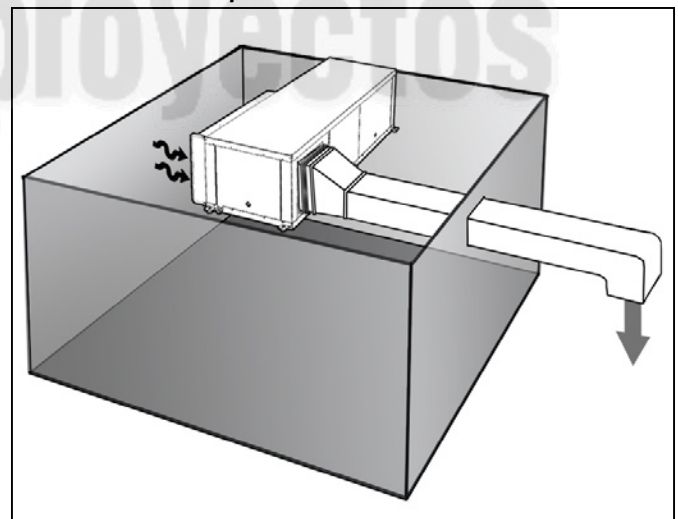

² 2007 ASHRAE Handbook – HVAC Applications, Sound and Vibration Control, “NC: Noise Criteria Method” page 47.31

³ 2007 ASHRAE Handbook – HVAC Applications, Sound and Vibration Control, “RC: Room Criteria Method” page 47.31

⁴ Standard AHRI 260-2001 - Sound Rating of Ducted Air Moving and Conditioning Equipment, Section 1.1 Purpose

Sound Performance - Paying Attention to the Details

Quiet HVAC equipment does not just happen. It's designed and built into every unit. Daikin-Applied's Enfinity Horizontal Ceiling Water Source Heat Pump quiet operation comes from decades of HVAC equipment expertise, rigorous attention to details and tenacious acoustic testing right from the start. The smallest of acoustic design details for each new product are painstakingly evaluated from an acoustic signature perspective. Acoustic evaluations take place in Daikin Applied's reverberant sound lab to ensure the proper attention is given to the acoustic details of each new product.

Daikin-Applied's Enfinity Horizontal Water Source Heat Pumps include many acoustic enhancements to minimize sound levels where it is needed the most.

Double Vibration Isolation

Provided as standard, the compressor mount has a unique dual-level vibration isolation system. The compressor is mounted on vibration isolation grommets resting on a heavy gauge mounting plate, and then isolated from the cabinet base with rubber grommets to minimize vibration transfer. The compressor is equipped with thermal overload protection and is located in a well-insulated compartment away from the air stream to minimize sound transmission.

Figure 4: Dual-Level Vibration Isolation System



Motor/Blower Housing

The standard blower motor is a multi-speed, Permanent Split Capacitor (PSC) type with thermal overload protection and is isolated from the fan housing using rubber isolators to minimize vibration transmission.

Using the MicroTech III controller combined with an optional Electronically Commutated Motor (ECM) fan motor in unit sizes 015 to 070 provides soft start, maintains consistent CFM over its static operating range. Sizes 007-012 use a constant torque ECM to deliver airflow at low motor RPM's to limit air borne sound levels.

Low Static Applications

The Enfinity horizontal ceiling units with ECM fan motors will get quieter in low static applications. The ECM used in this unit is smart enough to know its current draw and RPM to ensure that a constant air flow is delivered regardless of the static pressure. As the static pressure is reduced, so is the fan speed. When the fan speed is reduced, so are the sound levels. To ensure quiet system operation for low static applications, ECM fan motor is an option for Enfinity horizontal units.

Figure 5: ECM Motor



Field Adjustable ECM Fan Motors

If noise levels are too high, simply sliding a 4-position switch located in the unit will allow the user to select a lower air flow setting. Lower air flow means lower sound levels. Each Enfinity unit can be equipped with field adjustable air flow settings as a factory installed "special" option.

Figure 6: Adjustable Fan Speed Switch

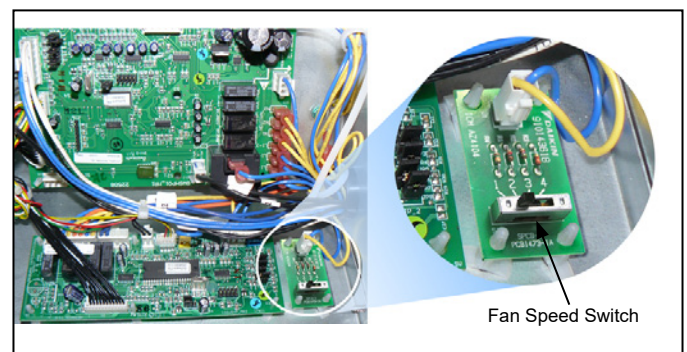

4-Legged Fan Mount

Rigorous laboratory test revealed an opportunity to reduce the fan sound levels. A special 4-legged fan mount, provided on Enfinity units, reduce vibrations between the fan motor and blower housing. This further reduces fan born sound levels.

Figure 7: 4-Legged Motor Mount

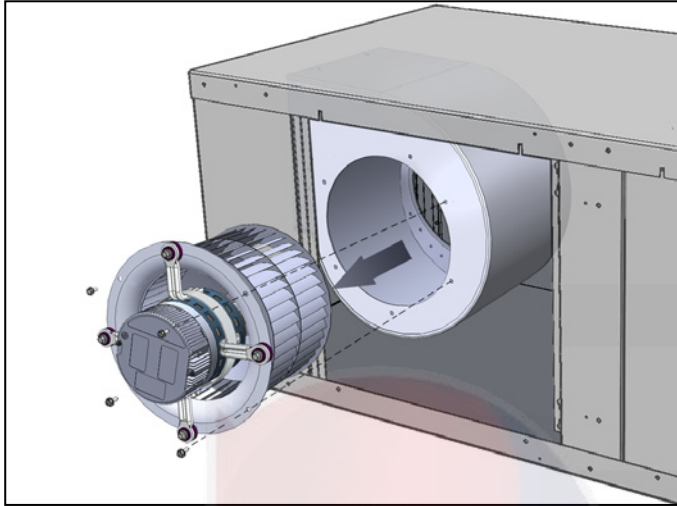

Acoustically Sealed Access Panels

Durable heavy galvanized steel cabinet construction are isolated from the fan and compressor compartments with a sealing gasket. Panel interiors and the bottom of the unit are covered with 1/2" thick, 1 1/2 lb. density, coated, acoustic type glass fiber insulation. Providing a near water tight seal ensures that noise levels are contained within the unit and not allowed to escape to the surroundings.

Figure 8: Acoustically Sealed Panels

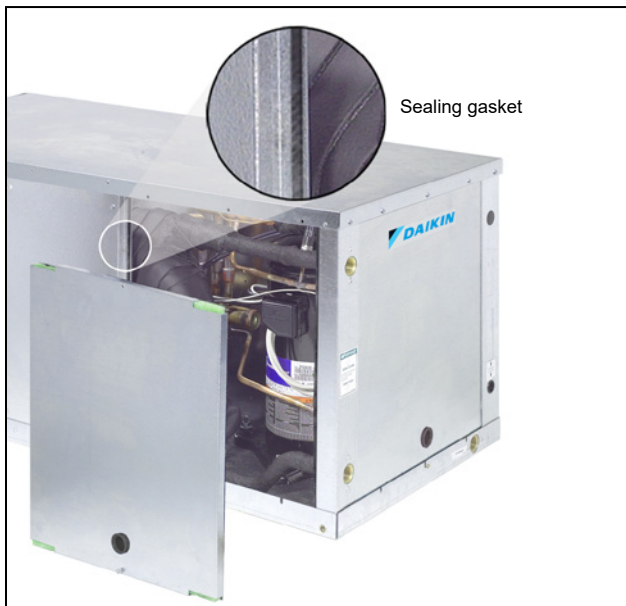

Premium Sound Package

An optional sound reduction kit adds a 3/4" thick acoustic foam panel of insulation to the fan section and a compressor blanket to help further reduce operating sound levels.

Figure 9: Sound Package



Field Installation Guidelines

It is always important to ensure that each unit is installed with the utmost attention to detail. Most importantly, follow the manufacturer's installation instructions! These installation guidelines should be followed to minimum vibration transmission to the building structure and to minimize discharge air and casing radiated sound levels.

Vibration Isolation Hanger Kits

Each horizontal unit is furnished with a mounting kit that includes heavy metal hanger brackets for hanging the unit from field-supplied hanger rods. Rubber isolators are included for sound and vibration attenuation, as are mounting washers, bolts and lock washers. The hangers are attached to fasteners at each corner of the unit, which are an integral part of the cabinet.

Figure 10: Hanger Brackets

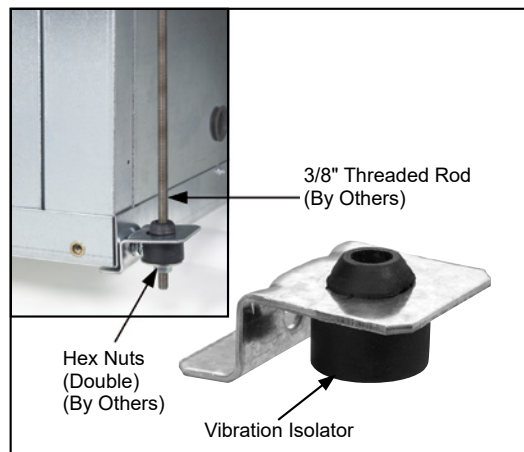

Suggested Duct Layout for Multiple Diffuser Application

- All ductwork should conform to industry standards of good practice as described in ASHRAE Systems Guide.
- Ductwork is normally applied to ceiling, closet or floor mounted heat pumps on the discharge of the unit.
- A discharge collar is provided on all models to facilitate ductwork connection. The inclusion of a canvas connector is recommended between the discharge collar and duct transformation (enlargement). The preferred configuration for ceiling models, a horizontal transformation, typically requires a duct depth similar to the vertical dimension of the unit collar.
- The heat pump location must allow the incorporation of an elbow, without turning vanes, after the transformation from discharge collar to full trunk duct to interrupt line-of-sight propagation of sound rays. One inch (25mm) acoustic duct lining should extend in both directions for a distance of at least two equivalent duct diameters.
- For maximum attenuation, the last five equivalent duct diameters before each air outlet (register) should be lined with one inch (25mm) acoustic duct liner.
- Elbows, tees or dampers create turbulence and distortion in the airflow. A straight length of 5 to 10 equivalent duct diameters is recommended to smooth out flow before the next fitting or terminal. Take-off of diffuser necks directly from the bottom of a trunk duct produces noise. If utilizing volume control dampers, locate them several equivalent duct diameters upstream from the air outlet.
- For a hotel, motel, dormitory or nursing home application, using a single duct register discharge from one machine, a maximum velocity of 500 to 600 fpm (2.54 to 3.048 m/s) is suggested. These applications involve system static pressures as low as 0.05 inches of water (0.012 kPa) and relatively short duct lengths. Discharge duct must include full lining and a square elbow without turning vanes. Return air for these applications should enter through a low side wall filter-grille and route up the stud space to ceiling plenum. Return air ceiling grilles are not recommended.
- For horizontal type heat pumps mounted in a suspended ceiling, an acoustic attenuator can be placed at the air inlet to attenuate line-of-sight sound transmission through return openings, see [Figure 13 on page 10](#).
- Avoid installing units directly above spaces where building occupants will reside (e.g. above office desks or classrooms) to reduce the requirement for noise attenuation. Do not place units above high traffic areas because service access may be limited during occupied hours. For example, units are typically

installed above the hallway drop ceiling in Schools and the supply and return air is routed directly into classrooms. Local code may require fire dampers to be used with this application.

Hoses & Hose Kits

Daikin sells a variety of flexible supply, return and condensate hoses and hose assemblies for connecting its water source heat pumps to a building's hard piping system, and acts as a sound attenuator for both the unit operating noise and hydraulic pumping noise. Piping systems should include supply and return shutoff valves in the design to allow removal of a unit without the need to shut down the entire heat pump system.

Figure 11: Supply and Return Hoses



Supply and return hoses have a swivel fitting at one end to facilitate removal of the unit for replacement or service.

Standard supply and return fire-rated hoses have either a thermoplastic rubber or synthetic polymer core with a braided covering of stainless steel. Fittings are either plated steel or brass.

Figure 12: Flexible, Condensate Hose



For condensate piping, Daikin offers flexible vinyl hose, steel braided hose or a long, clear, plastic hose with the necessary clamps for connection to the field piping. In most cases the use of plastic hose eliminates the need for insulation to be wrapped around the pipe to prevent sweating.

A threaded, factory-supplied condensate fitting allows the connection of PVC, flexible vinyl hose or steel braided hose. The condensate piping must be trapped at the unit and pitched away from the unit not less than 1/4" per foot.

Figure 13: Typical Ceiling Unit Installation

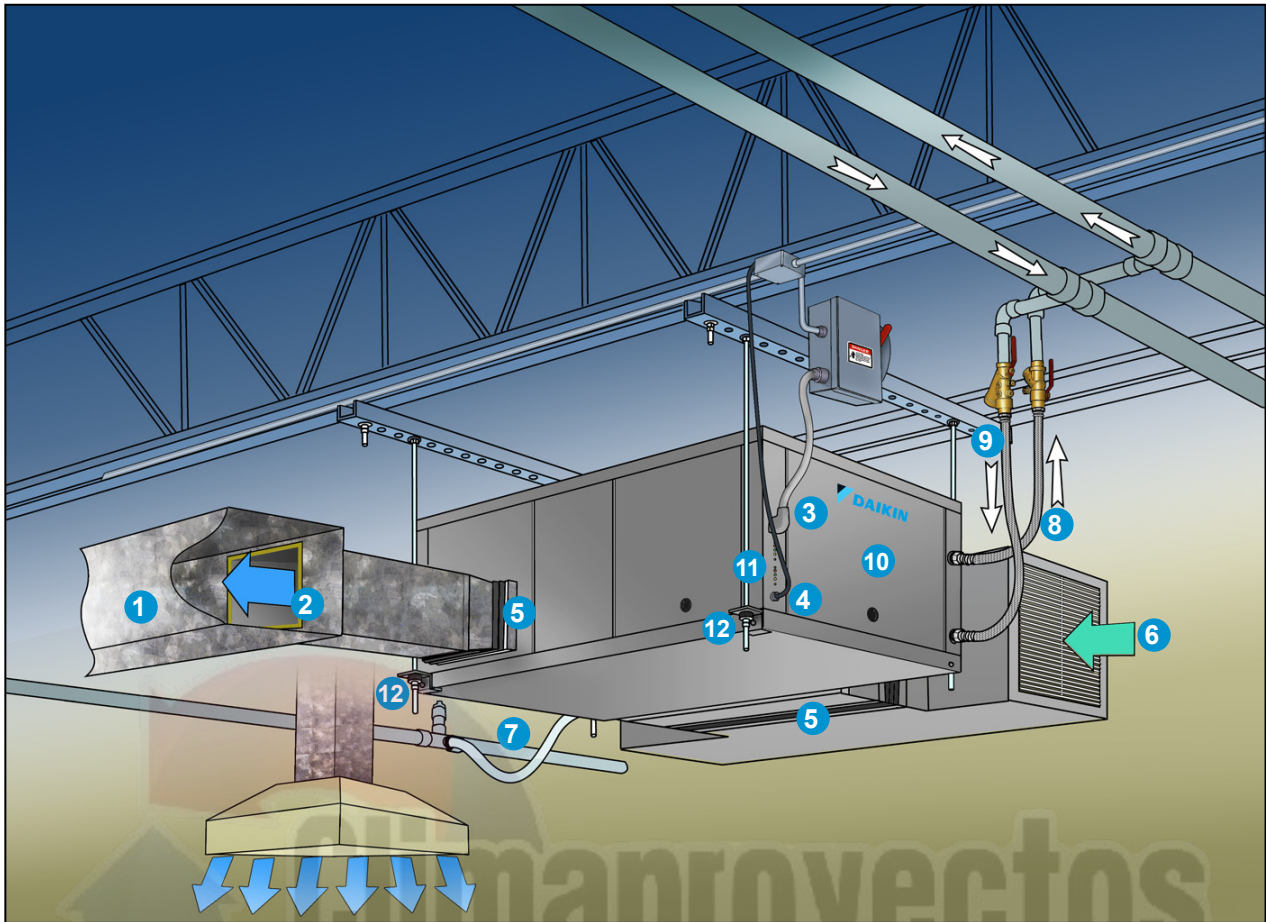

- | | |
|--|---|
| <ul style="list-style-type: none"> 1 Supply Air Ducting 2 Acoustical Lining (10 ft.) 3 Line Voltage - 7/8" (22mm) Hole 4 Low Voltage - 7/8" (22mm) Hole 5 Flexible Duct Collar 6 Return Air Grille 7 Flexible Condensate Drain Connection | <ul style="list-style-type: none"> 8 Flexible Return Hose with Flow Controller/Ball Valve (3/4" FPT) 9 Flexible Supply Hose with Y-Strainer/Ball Valve (3/4" FPT) 10 Access Panel to Controller 11 LED Annunciator Status Lights 12 Vibration Isolation Hanger |
|--|---|

Enfinity CCH/CCW Horizontal WSHP Standard Unit

ARI-260 Sound Power Data, High Cooling Mode

Table 2: Sound Power Data, High Cooling Mode, at .6" ESP

Unit Size	ARI-260 Sound Data ²															
	Casing Radiated, Ducted SA, Free RA, dB ⁴								Ducted Discharge, dB ³							
	125	250	500	1000	2000	4000	8000	dBA	125	250	500	1000	2000	4000	8000	dBA
007	67	59	57	50	43	40	36	58	63	62	55	53	54	48	43	60
009	67	60	57	51	44	40	37	58	63	63	57	56	56	50	46	62
012	67	61	57	51	45	40	38	59	65	64	59	61	57	52	49	65
019	68	62	56	49	46	40	39	58	63	56	54	53	54	52	45	60
024	72	63	58	53	48	42	41	61	63	58	59	58	57	56	48	64
030	74	64	59	56	53	59	46	65	64	59	60	59	60	58	52	65
036	76	66	62	58	54	52	46	65	64	61	62	61	60	57	53	66
042	78	68	64	59	53	50	42	67	71	63	64	63	61	59	54	68
048	79	69	65	61	55	52	45	68	71	65	65	64	63	61	51	69
060	80	73	67	63	62	59	54	71	71	67	66	65	64	63	56	71
070	82	74	67	66	64	62	59	73	74	68	67	68	66	64	57	73

- Notes:** 1. Cooling and heating conditions per ISO Standard 13256-1 water-loop rating conditions.
 2. Data based on sound measurements made in a reverberant room on representative units.

Table References:

- ² Data is based on rated CFM.
³ In accordance with ARI 260-2001, Section 4.5.5 "Free Inlet or Free Discharge".
⁴ In accordance with ARI 260-2001, Section 4.5.3 "Free Inlet (or Free Discharge) Combined with Casing Radiated Test"

ARI-260 Sound Power Data, Low Cooling Mode

Table 3: Sound Power Data, Low Cooling Mode, at .3" ESP

Unit Size	ARI-260 Sound Data ²															
	Casing Radiated, Ducted SA, Free RA, dB ⁴								Ducted Discharge, dB ³							
	125	250	500	1000	2000	4000	8000	dBA	125	250	500	1000	2000	4000	8000	dBA
007	67	59	56	50	42	39	36	57	62	60	53	52	53	47	41	59
009	67	60	56	51	43	38	36	58	62	61	55	55	55	49	44	61
012	66	60	56	50	44	38	37	58	64	62	57	60	56	51	47	64
019	67	60	55	49	46	38	37	57	60	54	53	51	52	51	42	58
024	70	60	56	52	48	39	39	59	60	56	58	57	56	55	46	63
030	73	61	57	54	51	54	41	62	61	57	59	58	59	57	50	64
036	75	63	60	55	51	47	41	63	61	58	61	57	57	55	50	64
042	77	64	62	56	50	45	37	65	68	60	63	59	58	57	51	65
048	77	64	62	60	52	48	40	66	68	62	64	59	60	59	48	67
060	78	68	64	62	59	55	49	68	68	64	65	60	61	61	53	68
070	80	69	64	65	61	58	54	70	71	65	66	63	63	62	54	70

- Notes:** 1. Cooling and heating conditions per ISO Standard 13256-1 water-loop rating conditions.
 2. Data based on sound measurements made in a reverberant room on representative units.

Table References:

- ² Data is based on rated CFM.
³ In accordance with ARI 260-2001, Section 4.5.5 "Free Inlet or Free Discharge".
⁴ In accordance with ARI 260-2001, Section 4.5.3 "Free Inlet (or Free Discharge) Combined with Casing Radiated Test"

Enfinity CCH/CCW Horizontal WSHP Standard Unit

ARI-260 Sound Power Data, High Heating Mode

Table 4: Sound Power Data, High Heating Mode at .6" ESP

Unit Size	ARI-260 Sound Data ²															
	Casing Radiated, Ducted SA, Free RA, dB ⁴								Ducted Discharge, dB ³							
	125	250	500	1000	2000	4000	8000	dBA	125	250	500	1000	2000	4000	8000	dBA
007	70	61	58	51	43	40	40	60	63	62	55	52	54	48	43	60
009	70	62	58	52	44	41	41	60	63	63	57	55	56	50	46	62
012	70	63	58	52	45	40	42	60	65	64	59	60	57	52	49	65
019	71	65	57	50	47	41	42	61	62	56	55	53	53	50	44	60
024	75	65	59	54	48	42	44	63	62	58	59	57	56	55	46	63
030	77	65	60	57	53	58	50	66	63	59	60	58	59	57	50	65
036	79	68	63	60	55	50	47	67	63	61	62	60	59	56	51	66
042	80	69	65	58	52	47	44	68	70	63	64	62	60	58	52	67
048	80	70	66	61	54	50	46	69	71	65	66	65	62	61	51	70
060	80	73	67	63	61	58	54	71	71	67	67	66	63	63	56	71
070	82	74	67	66	63	61	59	73	74	68	68	69	65	64	57	73

- Notes:** 1. Cooling and heating conditions per ISO Standard 13256-1 water-loop rating conditions.
 2. Data based on sound measurements made in a reverberant room on representative units.

Table References:

- ² Data is based on rated CFM.
³ In accordance with ARI 260-2001, Section 4.5.5 "Free Inlet or Free Discharge".
⁴ In accordance with ARI 260-2001, Section 4.5.3 "Free Inlet (or Free Discharge) Combined with Casing Radiated Test"

ARI-260 Sound Power Data, Low Heating Mode

Table 5: Sound Power Data, Low Heating Mode at .3" ESP

Unit Size	ARI-260 Sound Data ²															
	Casing Radiated, Ducted SA, Free RA, dB ⁴								Ducted Discharge, dB ³							
	125	250	500	1000	2000	4000	8000	dBA	125	250	500	1000	2000	4000	8000	dBA
007	70	61	57	51	42	39	40	59	62	60	53	51	53	47	41	59
009	70	62	57	52	43	39	40	60	62	61	55	54	55	49	44	61
012	69	62	57	51	44	38	41	59	64	62	57	59	56	51	47	63
019	70	63	56	50	47	39	40	59	59	54	54	51	51	49	41	58
024	73	62	57	53	48	39	42	61	59	56	58	56	55	54	44	62
030	76	62	58	55	51	53	45	64	60	57	59	57	58	56	48	64
036	78	65	61	57	52	45	42	65	60	58	61	56	56	54	48	63
042	79	65	63	55	49	42	39	66	67	60	63	58	57	56	49	65
048	78	65	63	60	51	46	41	66	68	62	65	60	59	59	48	67
060	78	68	64	62	58	54	49	68	68	64	66	61	60	61	53	68
070	80	69	64	65	60	57	54	70	71	65	67	64	62	62	54	70

- Notes:** 1. Cooling and heating conditions per ISO Standard 13256-1 water-loop rating conditions.
 2. Data based on sound measurements made in a reverberant room on representative units.

Table References:

- ² Data is based on rated CFM.
³ In accordance with ARI 260-2001, Section 4.5.5 "Free Inlet or Free Discharge".
⁴ In accordance with ARI 260-2001, Section 4.5.3 "Free Inlet (or Free Discharge) Combined with Casing Radiated Test"

Enfinity CCH/CCW Horizontal WSHP Standard Unit

ARI-260 Sound Power Data, High Fan Only Mode

Table 6: Sound Power Data, High Fan Only Mode at .6" ESP

Unit Size	ARI-260 Sound Data ²															
	Casing Radiated, Ducted SA, Free RA, dB ⁴								Ducted Discharge, dB ³							
	125	250	500	1000	2000	4000	8000	dBA	125	250	500	1000	2000	4000	8000	dBA
007	59	58	55	49	42	39	36	56	60	61	55	53	51	47	43	59
009	60	59	55	50	43	39	36	56	60	62	55	53	51	49	45	59
012	62	58	52	50	44	39	37	55	60	63	56	53	51	50	46	60
019	64	57	53	49	45	40	37	56	56	56	54	53	54	52	44	60
024	61	59	60	52	47	41	40	60	60	58	59	57	57	55	47	63
030	64	62	61	54	52	58	45	63	61	58	60	59	59	57	51	65
036	65	63	61	57	53	51	45	63	62	59	62	63	60	57	53	67
042	69	64	62	58	55	52	45	64	67	59	63	64	60	58	52	68
048	69	64	63	60	58	53	44	65	68	65	65	64	62	60	50	69
060	71	65	64	61	59	54	45	67	68	65	65	65	63	61	54	70
070	72	67	67	64	61	57	47	69	71	65	67	68	65	62	55	72

- Notes:** 1. Cooling and heating conditions per ISO Standard 13256-1 water-loop rating conditions.
 2. Data based on sound measurements made in a reverberant room on representative units.

Table References:

- ² Data is based on rated CFM.
³ In accordance with ARI 260-2001, Section 4.5.5 "Free Inlet or Free Discharge".
⁴ In accordance with ARI 260-2001, Section 4.5.3 "Free Inlet (or Free Discharge) Combined with Casing Radiated Test"

ARI-260 Sound Power Data, Low Fan Only Mode

Table 7: Sound Power Data, Low Fan Only Mode at .3" ESP

Unit Size	ARI-260 Sound Data ²															
	Casing Radiated, Ducted SA, Free RA, dB ⁴								Ducted Discharge, dB ³							
	125	250	500	1000	2000	4000	8000	dBA	125	250	500	1000	2000	4000	8000	dBA
007	59	58	54	48	41	38	35	55	58	59	53	52	50	46	41	58
009	60	59	54	50	42	37	35	56	58	60	53	52	50	48	43	58
012	62	57	51	49	43	37	36	54	59	61	54	52	50	49	44	59
019	63	55	52	49	45	38	35	55	53	54	53	51	52	51	41	58
024	59	56	58	51	47	38	38	58	57	56	57	56	56	54	45	62
030	63	59	59	52	50	53	40	60	58	56	58	58	58	56	49	64
036	64	60	59	54	50	46	40	60	59	56	58	59	57	55	50	64
042	68	60	60	55	52	47	40	61	64	56	59	60	57	56	49	64
048	67	59	60	59	55	49	39	63	65	62	63	59	59	58	47	66
060	69	60	61	60	56	50	40	64	65	62	63	60	60	59	51	67
070	70	62	64	63	58	53	42	67	68	62	64	63	62	60	52	68

- Notes:** 1. Cooling and heating conditions per ISO Standard 13256-1 water-loop rating conditions.
 2. Data based on sound measurements made in a reverberant room on representative units.

Table References:

- ² Data is based on rated CFM.
³ In accordance with ARI 260-2001, Section 4.5.5 "Free Inlet or Free Discharge".
⁴ In accordance with ARI 260-2001, Section 4.5.3 "Free Inlet (or Free Discharge) Combined with Casing Radiated Test"



This page left intentionally blank

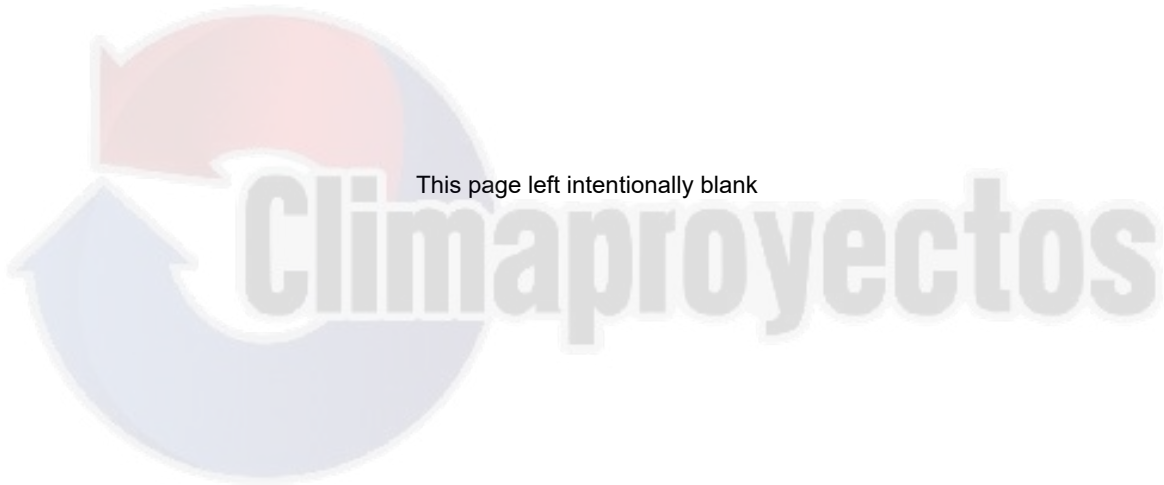



Daikin Applied Training and Development

Now that you have made an investment in modern, efficient Daikin equipment, its care should be a high priority. For training information on all Daikin HVAC products, please visit us at www.DaikinApplied.com and click on Training, or call 540-248-9646 and ask for the Training Department.

Warranty

All Daikin equipment is sold pursuant to its standard terms and conditions of sale, including Limited Product Warranty. Consult your local Daikin Applied representative for warranty details. Refer to Form 933-430285Y. To find your local Daikin Applied representative, go to www.DaikinApplied.com.

Aftermarket Services

To find your local parts office, visit www.DaikinApplied.com or call 800-37PARTS (800-377-2787). To find your local service office, visit www.DaikinApplied.com or call 800-432-1342.

This document contains the most current product information as of this printing. For the most up-to-date product information, please go to www.DaikinApplied.com.

Products manufactured in an ISO Certified Facility.