



United Technologies

PRODUCT SELECTION DATA



- Class A efficiency
- Extended operating envelope
- Reduced refrigerant charge
- Full list of options - maximum configurability

Air-Cooled Screw Chillers

30XA 252 - 1702



CARRIER participates in the ECP programme for LCP/HP
Check ongoing validity of certificate:
www.eurovent-certification.com
www.certiflash.com



AQUAFORCE

CONTENTS

Introduction.....	3
Customer Benefits	3
Very economical operation.....	3
Low operating sound levels.....	3
Easy and fast installation	3
Environmental care.....	4
Absolute reliability.....	4
Technical insights.....	4
Remote Management (Standard).....	4
Remote Management (EMM option).....	5
06T Screw Compressor	5
Novation® Heat Exchangers with Micro-Channel coil Technology.....	5
Options.....	6
Hydronic module (options 116B, C, F, G).....	8
Electrical data (options 116B, C, F, G)	8
Pump curve (options 116B, C, F, G).....	8
Total heat reclaim (option 50).....	9
Operating principle	9
Physical data (option 50)	9
DX free cooling system (option 118A)	10
Operating principle	10
Advantages of the DX free cooling system.....	10
Cooling capacities.....	10
Operating limits	10
Fan with available pressure (option 10).....	11
Physical data, sizes 252 to 852	12
Physical data, sizes 904 to 1702	13
Electrical data, sizes 252 to 902	14
Electrical data, sizes 902 to 1702	15
Part load performances.....	16
Sound spectrum	17
Operating limits	19
Operating range	19
Dimensions/clearances.....	20
30XA 1002 - MCHE heat exchanger (standard)	22
30XA 902-1002 - Cu/Al heat exchanger (option 254/255).....	22
30XA 1402-1502 module 2/2 - MCHE heat exchanger (standard).....	24
30XA 1402-1502 module 2/2 - Cu/Al heat exchanger (option 254/255).....	24
30XA 1702 module 2/2 - MCHE heat exchanger (standard).....	25
30XA 1702 module 2/2 - Cu/Al heat exchanger (option 254/255).....	25
Specification Guide	26
General description.....	26

30XA 252-1702

Nominal cooling capacity 267-1682 kW 50 Hz

Introduction

The Aquaforce liquid chillers are the premium solution for industrial and commercial applications where installers, consultants and building owners require optimal performances and maximum quality. The units are designed to operate up to 55 °C outside air temperature.

The Aquaforce liquid chillers are designed to meet current and future requirements in terms of energy efficiency and operating sound levels. They use the best technologies available today:

- Twin-rotor screw compressors with a variable capacity valve.
- Single refrigerant R-134a.
- Low-noise generation IV Flying Bird fans made of composite material.
- Aluminium micro-channel heat exchangers (MCHE)
- Touch Pilot control system.

To meet to all environmental and economic requirements, the Aquaforce is available in two versions:

One offers an extremely low noise level while at the same time boasting superior energy efficiency.

The other offers unequalled energy efficiency to satisfy the most stringent demands of building owners wanting to reduce operating costs to the minimum. This version is also recommended for applications in geographical zones where the air temperature is very high.

Customer Benefits

Very economical operation

- Exceptionally high full load and part load energy efficiency:
 - Eurovent energy efficiency class A and B (unit with high-efficiency option 119).
 - Standardised Eurovent values in accordance with EN 14511-3:2013: EER up to 3.3 and ESEER up to 4.2.
 - New twin-rotor screw compressor equipped with a high-efficiency motor and a variable capacity valve that permits exact matching of the cooling capacity to the load.
 - All aluminium condenser with high-efficiency micro-channels.
 - Flooded shell-and-tube evaporator to increase the heat exchange efficiency.
 - Electronic expansion device permitting operation at a lower condensing pressure and improved utilisation of the evaporator heat exchange surface (superheat control).
 - Economiser system with electronic expansion device for increased cooling capacity.

Low operating sound levels

- Compressors
 - Discharge dampers integrated in the oil separator (Carrier patent).
 - Silencer on the economiser return line.
 - Acoustic compressor and oil separator enclosure reducing radiated noise (option).
- Condenser section
 - Condenser coils in V-shape with an open angle, allowing quieter air flow across the coil
 - Low-noise 4th generation Flying Bird fans, made of a composite material (Carrier patent) are now even quieter and do not generate intrusive low-frequency noise
 - Rigid fan mounting preventing start-up noise (Carrier patent).

Easy and fast installation

- Integrated hydronic module (option)
 - Centrifugal low or high-pressure water pump (as required), based on the pressure loss of the hydronic installation
 - Single or dual pump (as required) with operating time balancing and automatic changeover to the back-up pump if a fault develops
 - Water filter protecting the water pump against circulating debris
 - High-capacity membrane expansion tank ensures pressurisation of the water circuit
 - Thermal insulation and aluminium protection (option)
 - Pressure sensor to check filter pollution and for direct numerical display of the water flow rate with an estimate of the instantaneous cooling capacity at the control interface
 - Water flow control valve.
- Simplified electrical connections
 - Main disconnect switch with high trip capacity
 - Transformer to supply the integrated control circuit (400/24 V).
- Fast commissioning
 - Systematic factory operation test before shipment
 - Quick-test function for step-by-step verification of the instruments, expansion devices, fans and compressors.

Environmental care

- R-134a refrigerant
 - Refrigerant of the HFC group with zero ozone depletion potential
 - 30% reduction in the refrigerant charge through the use of micro-channel heat exchangers
- Leak-tight refrigerant circuit
 - Reduction of leaks as no capillary tubes and flare connections are used
 - Verification of pressure transducers and temperature sensors without transferring refrigerant charge
 - Liquid line service valve for simplified maintenance (option).

Absolute reliability

- Screw compressors
 - Industrial-type screw compressors with oversized bearings and motor cooled by suction gas.
 - All compressor components are easily accessible on site minimising down-time.
 - Protection increased by an electronic board.
- Air condenser
 - All aluminium micro-channel heat exchanger (MCHE) with high corrosion resistance. The all aluminium design eliminates the formation of galvanic currents between aluminium and copper that cause coil corrosion in saline or corrosive environments.
- Evaporator
 - Thermal insulation with aluminium sheet finish (option) for perfect resistance to external aggression (mechanical and UV protection).
- Auto-adaptive control
 - Control algorithm prevents excessive compressor cycling (Carrier patent)
 - Automatic compressor unloading in case of abnormally high condensing pressure. If condenser coil fouling or fan failure occurs, the Aquaforce continues to operate, but at reduced capacity
- Exceptional endurance tests
 - Partnerships with specialised laboratories and use of limit simulation tools (finite element calculation) for the design of critical components.
 - Transport simulation test in the laboratory on a vibrating table. The test is based on a military standard and equivalent to 4000 km by truck.
 - Salt mist corrosion resistance test in the laboratory for increased corrosion resistance.

Technical insights

Touch Pilot Control

Touch Pilot control, 5" user interface



- New innovative smart control features:
 - An intuitive and user-friendly, coloured, 5" interface (7" optional)
 - Direct access to the unit's technical drawings and the main service documents
 - Screen-shots with concise and clear information in local languages
 - Complete menu, customised for different users (end user, service personnel and Carrier-factory technicians)
 - Easy access to the controller box with inclined touch screen mounting to ensure legibility under any lighting conditions
 - Safe operation and unit setting: password protection ensures that unauthorised people cannot modify any advanced parameters
 - Simple and "smart" intelligence uses data collection from the constant monitoring of all machine parameters to optimise unit operation.
- Energy management:
 - Internal time schedule clock controls chiller on/off times and operation at a second set-point
 - The DCT (Data Collection Tool) records the alarms history to simplify and facilitate service operations.

Remote Management (Standard)

- Units with Touch Pilot control can be easily accessed from the internet, using a PC with an Ethernet connection. This makes remote control quick and easy and offers significant advantages for service operations.
- Aquaforce is equipped with an RS485 serial port that offers multiple remote control, monitoring and diagnostic possibilities. When networked with other Carrier equipment through the CCN (Carrier Comfort Network - proprietary protocol), all components form a HVAC system fully-integrated and balanced through one of the Carrier's network system products, like the Chiller System Manager or the Plant System Manager (optional).
- Aquaforce also communicates with other building management systems via optional communication gateways.
- The following commands/visualisations are possible from remote connection:
 - Start/stop of the machine
 - Dual set-point management: through a dedicated contact is possible to activate a second set-point (example: unoccupied mode)
 - Demand limit setting: to limit the maximum chiller capacity to a predefined value
 - Water pump control: these outputs control the contactors of one/two evaporator water pumps

- Water pumps on reversal (only with options 116C/116G): these contacts are used to detect a water pump operation fault and automatically change over to the other pump
- Operation visualisation: indication if the unit is operating or if it's in stand-by (no cooling load) - alarm visualisation.

Remote Management (EMM option)

- The Energy Management Module (EMM) offers extended remote control possibilities:
 - Room temperature: Permits set-point reset based on the building indoor air temperature (if Carrier thermostat are installed)
 - Set-point reset: Ensures reset of the cooling set-point based on a 4-20 mA or 0-10 V signal
 - Demand limit: Permits limitation of the maximum chiller capacity based on 0-10 V signal
 - Demand limit 1 and 2: Closing of these contacts limits the maximum chiller capacity to two predefined values
 - User safety: This contact can be used for any customer safety loop; opening the contact generates a specific alarm
 - Ice storage end: When ice storage has finished, this input permits return to the second set-point (unoccupied mode)
 - Time schedule override: Closing of this contact cancels the time schedule effects
 - Out of service: This signal indicates that the chiller is completely out of service
 - Chiller capacity: This analogue output (0-10 V) gives an immediate indication of the chiller capacity
 - Alert indication: This volt-free contact indicates the necessity to carry out a maintenance operation or the presence of a minor fault
 - Compressors running status: Set of outputs (as many as the compressors number) indicating which compressors are running.

06T Screw Compressor

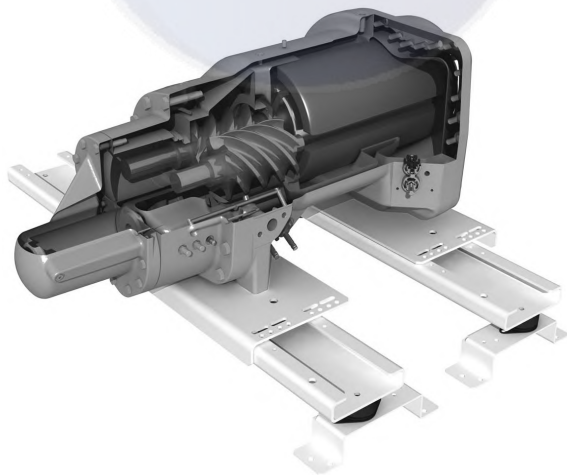

The Carrier 06T screw compressor benefits from Carrier's long experience in the development of twin-rotor screw compressors. The compressor is equipped with bearings with oversized rollers, oil pressure lubricated for reliable and durable operation, even at maximum load.

A variable control valve controlled by the oil pressure permits infinitely variable cooling capacity. This system allows optimal adjustment of the compressor cooling capacity and ensures exceptionally high stability of the chilled water leaving temperature.

Among the other advantages: if a fault occurs e.g. if the condenser is fouled or at very high outside temperature, the compressor does not switch off, but continues operation with a reduced capacity (unloaded mode).

The compressor is equipped with a separate oil separator that minimises the amount of oil in circulation in the refrigerant circuit and with its integrated silencer considerably reduces discharge gas pulsations for much quieter operation.

Novation® Heat Exchangers with Micro-Channel coil Technology

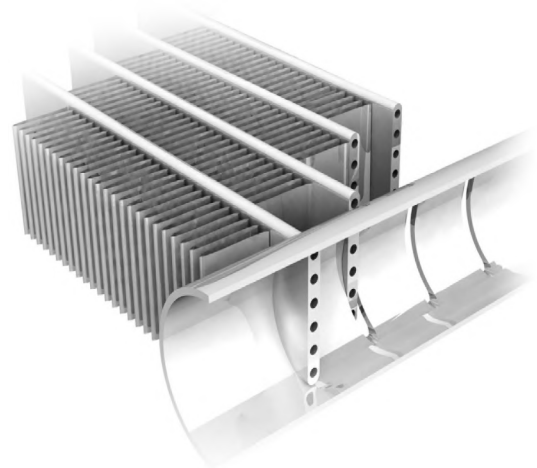

Already utilised in the automobile and aeronautical industries for many years, the MCHE micro-channel heat exchanger used in the Aquaforce is entirely made of aluminium. This one-piece concept significantly increases its corrosion resistance by eliminating the galvanic currents that are created when two different metals (copper and aluminium) come into contact in traditional heat exchangers. Unlike traditional heat exchangers the MCHE heat exchanger can be used in moderate marine and urban environments (Carrier recommendation).

From an energy efficiency point-of-view the MCHE heat exchanger is approximately 10% more efficient than a traditional coil and allows a 30% reduction in the amount of refrigerant used in the chiller. The low thickness of the MCHE reduces air pressure losses by 50% and makes it susceptible to very little fouling (e.g. by sand). Cleaning of the MCHE heat exchanger is very fast using a high-pressure washer.

To ensure constant level of performance during time and protect coils from early deterioration or, what's worse, refrigerant leaks, Carrier offers (as options) dedicated treatments for installations in corrosive environments.

The Novation® heat exchangers with Enviro-Shield protection (option 262) are recommended for installations in moderately corrosive environments. The Enviro-Shield protection utilises corrosion inhibitors which actively arrest oxidation in case of mechanical damage.

The Novation® heat exchangers with the exclusive Super Enviro-Shield protection (option 263) are recommended for installations in corrosive environments. The Super Enviro-Shield protection consist in an extremely durable and flexible epoxy coating uniformly applied over all coil surfaces for complete isolation from the contaminated environment.

Options

Options	No.	Description	Advantages	Use for 30XA range
Corrosion protection, traditional coils	2B	Factory application of Blygold Polual treatment on the copper/aluminium coils	Improved corrosion resistance, recommended for industrial, rural and marine environments	252-1702 (Not available for the sizes 504, 854, 904)
Corrosion protection, traditional coils	3A	Fins made of pre-treated aluminium (polyurethane and epoxy)	Improved corrosion resistance, recommended for moderate marine and urban environments	252-1702 (Not available for the sizes 504, 854, 904)
Medium-temperature brine solution	5	Implementation of new algorithms of control and evaporator redesign to allow chilled brine solution production down to -6 °C when ethylene glycol is used (-3 °C with propylene glycol)	Covers specific applications such as ice storage and industrial processes	252-1702 (Not available for the sizes 504, 854, 904)
Low-temperature brine solution	6	Implementation of new algorithms of control and evaporator redesign to allow chilled brine solution production down to -12 °C when ethylene glycol is used (-8 °C with propylene glycol)	Covers specific applications such as ice storage and industrial processes	252-1702 (Not available for the sizes 504, 854, 904)
Unit equipped for air discharge ducting	10	Fans equipped with discharge connection flanges - maximum available pressure 60 kPa	Facilitates connections to the discharge ducts	252-1702 (Not available for the sizes 504, 854, 904)
IP54 control box	20A	Increased leak tightness of control boxes	Protects the inside of the electrical box from dusts and sand. In general this option is recommended for installations in polluted environments	252-1702
Tropicalisation of the electrical box	22	Electrical box equipped with an electrical heater and a fan. Electrical connections on the compressors painted with a special varnish and covered with an anti-condensation foam.	Grant safe operation in typical "tropical" climate. This option is recommended for all applications where humidity inside the electrical box can reach 80% at 40 °C and unit can remain in stand-by for a long time under this conditions.	252-1702
Grilles and enclosure panels	23	Metal grilles on the 4 unit sides, plus side enclosure panels at each end of the coil	Improves aesthetics, protection against intrusion to the unit interior, coil and piping protection against impacts.	252-1702
Enclosure panels	23A	Side enclosure panels at each end of the coil	Improves aesthetics, coil and piping protection against impacts.	252-1702
Winter operation down to -20 °C	28	Fan speed control via frequency converter	Stable unit operation for air temperature down to -20 °C	252-1702
Evaporator frost protection	41A	Electric resistance heater on the evaporator and discharge valve	Evaporator frost protection down to -20 °C outside temperature	252-1702
Evap. and hydraulic mod. frost protection	41B	Electric resistance heater on evaporator, discharge valve and hydronic module	Evaporator and hydronic module frost protection down to -20 °C outside temperature	252-1702
Total heat recovery	50	Unit equipped with additional heat exchanger in parallel with the condenser coils.	Production of free hot-water simultaneously with chilled water production	252-1702 (Not available for the sizes 504, 854, 904)
Master/slave operation	58	Unit equipped with supplementary water outlet temperature sensor kit to be field-installed allowing master/slave operation of two units connected in parallel	Optimised operation of two chillers connected in parallel with operating time equalisation	252-1702
Single power connection point	81	Unit power connection via one main supply connection	Quick and easy installation	1112-1502
Service valve set	92	Liquid line valve (evaporator inlet), compressor suction and discharge line valves and economiser line valve	Allow isolation of various refrigerant circuit components for simplified service and maintenance	252-1702
Compressor discharge valves	93A	Shut-off valve on the compressor discharge piping	Simplified maintenance	252-1702
Evaporator with one pass more	100A	Evaporator with one pass more on the water side	Optimise chiller operation when the chilled water circuit is designed with low waterflows (high delta T evaporator inlet/outlet)	252-1702
Evaporator with one pass less	100C	Evaporator with one pass on the water side. Evaporator inlet and outlet on opposite sides.	Easy to install, depending on site. Reduced pressure drops	252-1002
21 bar evaporator	104	Reinforced evaporator for extension of the maximum water-side service pressure to 21 bar (standard 10 bar)	Covers applications with a high water column evaporator side (typically high buildings)	252-1702
Reversed evaporator water connections	107	Evaporator with reversed water inlet/outlet	Easy installation on sites with specific requirements	252-1702
HP single-pump hydronic module	116B	Complete hydronic module equipped with water filter, expansion tank with relief valve, one high pressure pump, drain valve and water flow control valve. For more details, refer to the dedicated chapter	Plug & play approach	252-502 (Not available for the size 504)
HP dual-pump hydronic module	116C	Complete hydronic module equipped with water filter, expansion tank with relief valve, two high pressure pumps, drain valve and water flow control valve. For more details, refer to the dedicated chapter	Plug & play approach. Increased system reliability	252-502 (Not available for the size 504)
LP single-pump hydronic module	116F	Complete hydronic module equipped with water filter, expansion tank with relief valve, one low pressure pump, drain valve and water flow control valve. For more details, refer to the dedicated chapter	Plug & play approach	252-502 (Not available for the size 504)
LP dual-pump hydronic module	116G	Complete hydronic module equipped with water filter, expansion tank with relief valve, two low pressure pumps, drain valve and water flow control valve. For more details, refer to the dedicated chapter	Plug & play approach. Increased system reliability	252-502 (Not available for the size 504)
Dx Free Cooling system on two circuits	118A	Patented Carrier free-cooling system with cooling micro-pump on both refrigerant circuits. Operation without glycol, no extra free-cooling coil. See Dx Free-cooling option chapter	Energy savings for applications with cooling demand throughout the entire year	252-1002 (Not available for the sizes 504, 854, 904)

Options	No.	Description	Advantages	Use for 30XA range
High energy efficiency	119	Higher air flow through the condenser coils improving heat exchange efficiency on the condenser	Energy cost reduction and extended operating envelope (full load operation at higher air temperature)	252-1702 (Mandatory for the sizes 504, 854, 904)
CCN to J-Bus gateway	148B	Two-directional communication board complying with JBus protocol	Connects the unit by communication bus to a building management system	252-1702
CCN to Lon gateway	148D	Two-directional communication board complying with Lon Talk protocol	Connects the unit by communication bus to a building management system	252-1702
Bacnet over IP gateway	149	Two high-speed communication using BACnet protocol over Ethernet network (IP)	Easy and high-speed connection by ethernet line to a building management system. Allows access to multiple unit parameters	252-1702
Energy Management Module	156	Control board with additional inputs/outputs. See Energy Management Module option chapter	Extended remote control capabilities (Set-point reset, ice storage end, demand limits, boiler on/off command...)	252-1702
Touch Pilot control, 7" user interface	158A	Touch Pilot control supplied with a 7 inch colour touch screen user interface	Enhanced ease of use	252-1702
Leak detection	159	0-10 V signal to report any refrigerant leakage in the unit directly on the controller (the leak detector itself must be supplied by the customer)	Immediate customer notification of refrigerant losses to the atmosphere, allowing timely corrective actions	252-1702
Dual relief valves installed w/ 3-way valve	194	Three-way valve upstream of the relief valve on the evaporator and the oil separator	Valve replacement and inspection facilitated without refrigerant loss. Comforms to European standard EN378/BGVD4	252-1382
Compliance with Swiss regulations	197	Additional tests on the water heat exchangers: supply (additional of PED documents) supplementary certificates and test certifications	Conformance with Swiss regulations	252-1702
Compliance with Russian regulations	199	GOST certification	Conformance with Russian regulations	252-1702
Compliance with Australian regulations	200	Unit approved to Australian code	Conformance with Australian regulations	252-1702
Power factor correction	231	Capacitors for automatic regulation of power factor (cos phi) value to 0,95.	Reduction of the real electrical power, compliance with minimum power factor limit set by utilities	252-1002
Traditional coils (Cu/Al)	254	Coils made of copper tubes with aluminium fins	None	252-1702 (Not available for the sizes 504, 854, 904)
Traditional coils (Cu/Al) without slots	255	Coils made of copper tubes with aluminium fins without slots	None	252-1702 (Not available for the sizes 504, 854, 904)
Insulation of the evap. in/out ref.lines	256	Thermal insulation of the evaporator entering/leaving refrigerant lines with flexible, anti-UV insulant	Prevents condensation on the evaporator entering/leaving refrigerant lines	252-1702
Low noise level	257	Sound insulation of main noise sources (includes option 279)	5 to 12 dB(A) quieter than standard unit (depending model and size). Refer to the physical data table for detailed values	252-1702
Very low sound level	258	Enhanced sound insulation of main noise sources combined with fans speed management (includes option 279)	2 to 3 dB(A) quieter than unit with option 257. Refer to the physical data table for detailed values	452-1702 (Not available for the sizes 504, 854, 904)
Enviro-Shield anti-corrosion protection	262	Coating by conversion process which modifies the surface of the aluminum producing a coating that is integral to the coil. Complete immersion in a bath to ensure 100% coverage. No heat transfer variation, tested 4000 hours salt spray per ASTM B117	Improved corrosion resistance, recommended for use in moderately corrosive environments	252-1702
Super Enviro-Shield anti-corrosion protection	263	Extremely durable and flexible epoxy polymer coating applied on micro channel heat exchangers by electro coating process, final UV protective topcoat. Minimal heat transfer variation, tested 6000 hours constant neutral salt spray per ASTM B117, superior impact resistance per ASTM D2794	Improved corrosion resistance, recommended for use in extremely corrosive environments	252-1702
Welded evaporator water connection kit	266	Victaulic piping connections with welded joints	Easy installation	252-1702
Compressor enclosure	279	Compressor sound enclosure	4 to 10 dB(A) quieter than standard unit. Refer to the physical data table for detailed values	252-1702
Evaporator with aluminium jacket	281	Evaporator covered with an aluminium sheet for thermal insulation protection	Improved resistance to aggressive climate conditions	252-1702
230V electrical plug	284	230V AC power supply source provided with plug socket and transformer (180 VA, 0,8 Amps)	Permits connection of a laptop or an electrical device during unit commissioning or servicing	252-1702
Carrier Connect link (BSS regions only)	298	3G Router board NOTE 1: Require option 149 NOTE 2: When more than one machine is installed on site, only one of them shall be equipped with option 298 while all of them must be equipped with option 149 NOTE 3: If the Carrier® PlantCTRL™ is on site, option 298 shall be integrated in the Carrier® PlantCTRL™ while option 149 is still mandatory for each single unit.	Enabler for Carrier connect service offer	252-1702

Hydronic module (options 116B, C, F, G)

Typical water circuit diagram

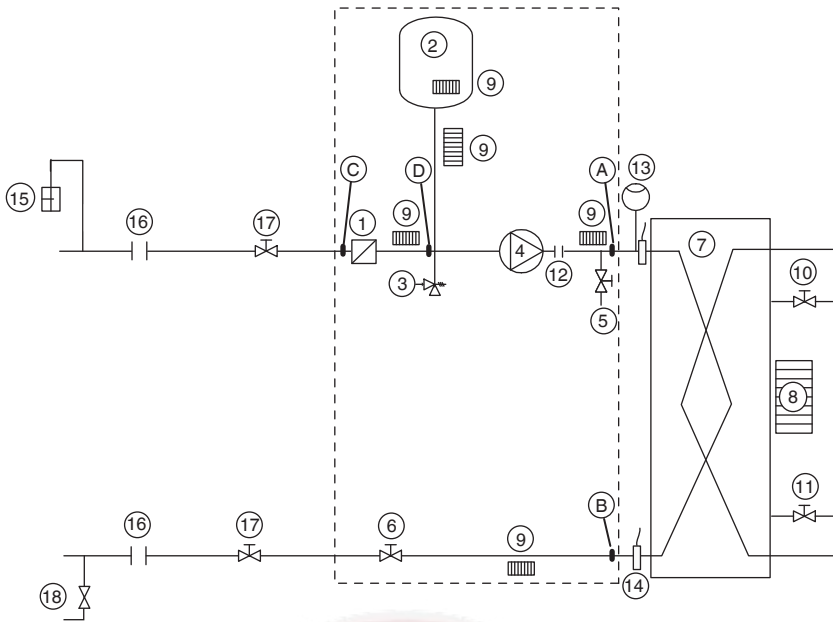

Legend

Components of unit and hydronic module

- A Pressure sensor (A-B = Δp evaporator)
- B Pressure sensor
- C Pressure sensor (C-D = Δp water filter)
- D Pressure sensor
- 1 Victaulic screen filter
- 2 Expansion tank
- 3 Relief valve
- 4 Available pressure pump
- 5 Drain valve
- 6 Water flow control valve
- 7 Evaporator
- 8 Evaporator defrost heater (option)
- 9 Hydronic module defrost heater
- 10 Air vent (evaporator)
- 11 Water purge (evaporator)
- 12 Expansion compensator (flexible connections)
- 13 Flow switch
- 14 Water temperature sensor

System components (field-supplied)

- 15 Air vent
- 16 Flexible connection
- 17 Shut-down valves
- 18 Charge valve
- Hydronic module (option)

Electrical data (options 116B, C, F, G)

The pumps that are factory-installed in these units have motors with efficiency class IE2 (motors < 7.5kW) and IE3 (motors > 7.5kW). The additional electrical data required by regulation 640/2009 is given in the installation, operation and maintenance manual.

This regulation concerns the application of directive 2005/32/EC on the eco-design requirements for electric motors.

Pump curve (options 116B, C, F, G)

Conditions and limits of use:

- Fresh water 20 °C
- In case of use of the glycol, the maximum water flow is reduced.
- When the glycol is used, it's limited to 40%.

Low-pressure pump (hydronic module option)

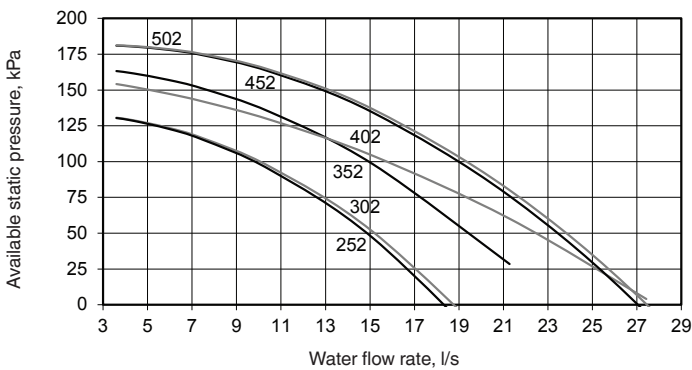

High-pressure pump (hydronic module option)

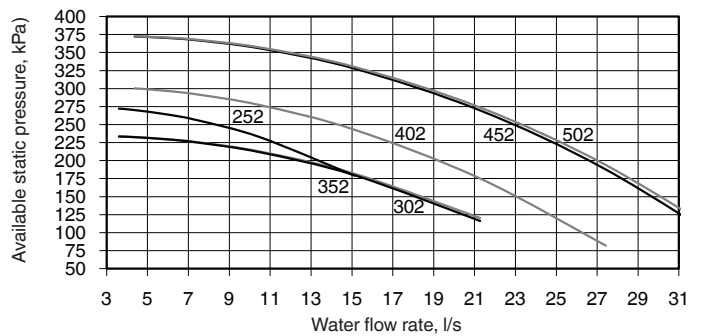

Total heat reclaim (option 50)

Suitable for heating, domestic hot water preparation, agriculture and food industry, industrial processes and other hot-water requirements.

With the total heat reclaim option it is possible to reduce the energy consumption bill considerably compared to conventional heating equipment such as fossil fuel boilers or electric water tanks.

Operating principle

If hot water production is required, the compressor discharge gases are directed towards the heat reclaim condenser. The refrigerant releases its heat to the hot water that leaves the condenser at a temperature of up to 60 °C. In this way 100% of the heat rejected by the liquid chiller can be used to produce hot water. When the demand for heat is satisfied, the hot gas is again directed towards the air condenser where the heat is rejected to the outside air by the fans. Hot water temperature control is ensured by the chiller Touch Pilot control that independently controls the reclaim operation of each refrigerant circuit.

Note: Heat reclaim is only possible, if the unit produces cold water at the same time.

Condenser water temperature (°C)	Minimum	Maximum
Entering temperature at start-up	12.5*	55
Entering temperature during operation	20	55
Leaving temperature during operation	25	60
Evaporator water temperature (°C)		
Entering temperature at start-up	-	45
Entering temperature during operation	6.8	21

* The entering water temperature at start-up must not fall below 12.5 °C. For installations with a lower temperature a three-way valve must be used.

Note: If the evaporator leaving water temperature is below 4 °C, a glycol-water solution or the frost protection option must be used.

In part-load operation, the limitation of the condenser leaving water temperature is due to the operating range of the screw compressor. If the condenser leaving water temperature is above the limit value given in the curves on the right, the unit will automatically change over to the mode without heat recovery:

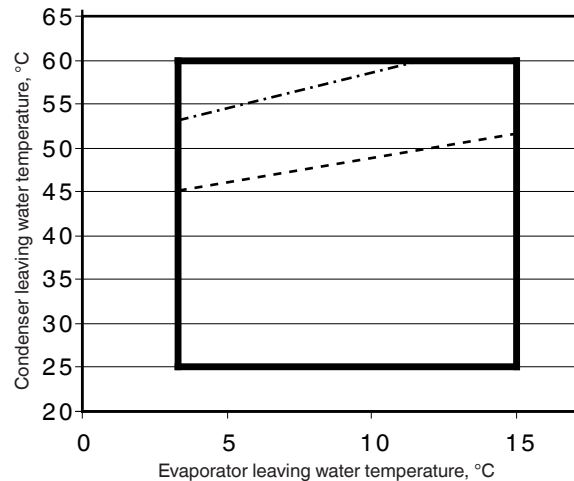

— Full load
 - - - Part load limit, approx. 60%
 . . . Minimum load limit, approx. 30%

Part load operating limits (evaporator leaving water temperature = 7 °C)

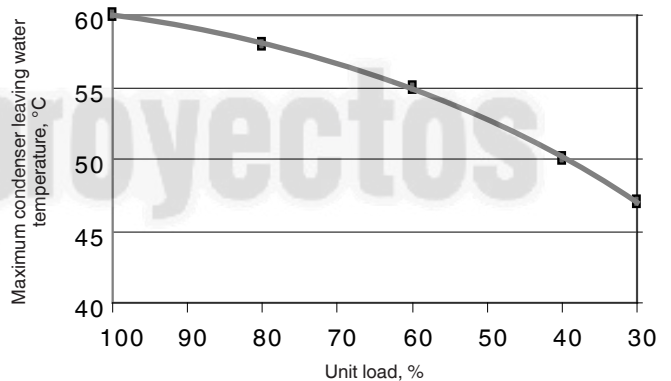

Physical data (option 50)

These are the same as for the standard unit except:

30XA heat reclaim mode		252	302	352	402	452	502	602	702	752	802	852	902	1002
Cooling capacity*	kW	265	295	317	385	444	500	616	679	721	789	830	891	990
Heating capacity in heat reclaim mode	kW	340	377	406	487	562	628	773	845	909	988	1042	1121	1246
Total power input (unit)*	kW	81.9	89.6	98.0	112.7	128.7	140.4	171.7	182.9	205.6	218.5	232.8	252.1	281.6
Total energy efficiency ratio (EER)	kW/kW	3.23	3.29	3.23	3.41	3.45	3.56	3.59	3.71	3.51	3.61	3.57	3.53	3.51
Total coefficient of performance (COP)	kW/kW	4.15	4.20	4.14	4.33	4.36	4.49	4.51	4.63	4.43	4.53	4.49	4.46	4.44
Operating weight**	kg	3920	3960	3970	4930	5050	5550	6670	6730	7130	7350	7890	8340	8950
Condenser diameter	in	10	10	10	12	14	14	12+12	12+12	14+12	14+12	14+12	14+14	14+14
Refrigerant charge														
Circuit A	kg	37	35	35	51	52	59	58	58	65	69	72	69	91
Circuit B	kg	39	37	37	37	37	36	59	62	58	65	63	76	89
Heat reclaim condenser		Flooded shell-and-tube condenser												
Water volume	l	38	38	38	55	68	68	55 + 55	55 + 55	68 + 55	68 + 55	68 + 55	68 + 68	68 + 68
Water connection		Victaulic												
Nominal diameter	in	3	3	3	4	4	4	4	4	4	4	4	4	4
Actual outside diameter	mm	88.9	88.9	88.9	114.3	114.3	114.3	114.3	114.3	114.3	114.3	114.3	114.3	114.3

* Nominal conditions: Entering/leaving water temperature: evaporator 12 °C/7 °C; heat reclaim condenser: 40 °C/45 °C; evaporator and heat reclaim condenser fouling factor = 0 m² K/kW. Gross performances, not in accordance with EN14511-3:2011. These performances do not take into account the correction for the proportional heating capacity and power input generated by the water pump to overcome the internal pressure drop in the heat exchanger.

** Weights are for guidance only

DX free cooling system (option 118A)

The DX free cooling option permits significant energy savings for all applications that require cooling in winter. In the free cooling mode the compressors are stopped and only the fan and cooling micro-pump are running. The changeover from compressor cooling mode to free cooling mode is automatically controlled by the Touch Pilot control, based on the chiller heat load and the temperature difference between chilled water and ambient air.

Important: In order to optimise chiller performances, it is recommended to use the leaving water set point reset function.

Operating principle

When the chilled water-air temperature difference exceeds a threshold value, the Touch Pilot control carries out a comparison between the instantaneous chiller cooling capacity and the available free cooling capacity. If the operating conditions allow free cooling operation, the compressors are stopped, a set of valves on the suction piping connects the evaporator with the condenser, allowing the migration of the refrigerant vapours to the condenser. The refrigerant condenses in the condenser coils, and the cooling micro-pump transports the liquid to the evaporator. The cooling capacity in free cooling mode is controlled by the opening of the electronic expansion valve (EXV).

Operation in combined FC (free-cooling) and MC (mechanical cooling) mode is possible in the two independent refrigerant circuits. This can optimise the free-cooling operations and at the same time ensures that the cooling requirements of the system are met.

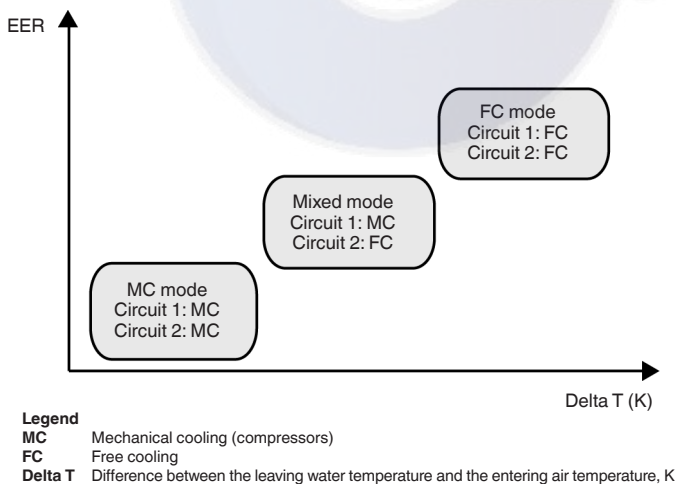

Advantages of the DX free cooling system

- Operation without glycol
Unlike traditional hydronic free-cooling systems that require the use of a glycol solution, the Aquaforce DX free cooling chiller works with pure water. The evaporator is protected against frost down to -20 °C by an electric resistance heater (option).
- Low water pressure losses
The Aquaforce DX free cooling chiller does not include a three-way valve nor free cooling coils connected in series with the evaporator. The Aquaforce free cooling chiller has the same water pressure losses as a standard chiller.
- Weight and dimensions gain
 - The DX free cooling option has practically no impact on the weight of the liquid chiller.
 - The Aquaforce free cooling chiller has the same dimensions as a standard chiller.
- Increased energy efficiency
 - In free cooling mode only the fans and the cooling micro-pump run. At an air-water temperature difference of 10 K for example the average chiller energy efficiency (EER) is 23 (kW/kW).
 - In the mechanical cooling mode chiller thermal and energy performances are not reduced by the use of a water-glycol solution.
 - As the pressure losses of the water circuit are low, the water pumps use less energy.

Cooling capacities

30XA 252-1002 in free-cooling mode (option 118A)

30XA	LWT °C	Condenser entering air temperature, °C					
		0		-5		-10	
		Qc kW	EER kW/kW	Qc kW	EER kW/kW	Qc kW	EER kW/kW
252	10	143.4	21.9	183.2	27.7	186.4	28.0
302		143.0	22.3	182.7	28.3	185.9	28.5
352		142.9	22.0	182.6	27.9	185.8	28.1
402		182.8	20.2	255.1	27.9	274.8	29.8
452		182.6	20.0	255.0	27.7	274.6	29.6
502		202.5	19.9	284.2	27.7	306.9	29.6
602		253.1	19.7	373.1	28.7	415.5	31.7
702		276.6	20.2	407.5	29.5	453.8	32.6
752		271.5	19.9	400.1	29.1	445.6	32.2
802		274.9	19.7	405.0	28.8	451.1	31.8
852		323.6	19.9	476.8	29.1	531.0	32.2
902		328.1	20.4	483.4	29.8	538.4	32.9
1002		368.1	20.6	542.3	30.2	603.9	33.3

Note: Calculations according to the standard performances (in accordance with EN14511-3:2011) and Eurovent-certified. Evaporator fouling factor 0 m² K/W.

Legend

- LWT Leaving water temperature, °C
- Qc Cooling capacity, kW
- EER Energy efficiency ratio, kW/kW

Operating limits

	Free-cooling mode	Mechanical cooling mode (compressors)
Evaporator water temperature, °C		
Minimum leaving water temperature	3.3	3.3
Maximum leaving water temperature	25	15
Condenser air temperature, °C		
Minimum leaving air temperature	-20	-20*
Maximum leaving air temperature	20	55

* For operation at an air temperature below -10 °C option 28 (winter operation) is required.

Fan with available pressure (option 10)

This option allows a duct connection at the discharge side of the condenser fan. The unit is supplied with axial fans with a speed of 15.8 r/s (same for option 119), each equipped with a duct connection frame. The chiller can operate at a static discharge pressure of up to 60 Pa with reduced performance. The performances can be estimated using the coefficients below, applicable at the conditions shown in the curve below.

■ Selection method

The base performances for the calculation are those of option 119 (only MCHE heat exchangers, see pages 24 and 25 of this manual). To obtain the capacities at the static duct pressure, apply the coefficients shown in the tables on the right.

30XA option 10		Correction factors			
Fan pressure drop	Pa	0	20	40	60
Air flow	%	0	-3.5	-7.5	-12.1
Cooling capacity	%	0	-0.5	-1.0	-1.5
EER	%	0	-1.5	-3.5	-5.0
Power input	%	0	+1.0	+2.5	+3.5

Note: All fans must be individually ducted.

■ Example

30XA 802 with 40 Pa pressure drop
 Performances option 119 at the following conditions:
 - 35 °C outside air temperature
 - 12/7 °C entering/leaving water temperature

		0 Pa for option 119	Correction factors	40 Pa
Air flow	l/s	54167	-7.5%	50119
Cooling capacity	kW	787	-1.0%	779
EER	kW/kW	3.13	-3.5%	3
Power input	kW	251	+2.5%	258

Application limits for correction factors for high air temperatures

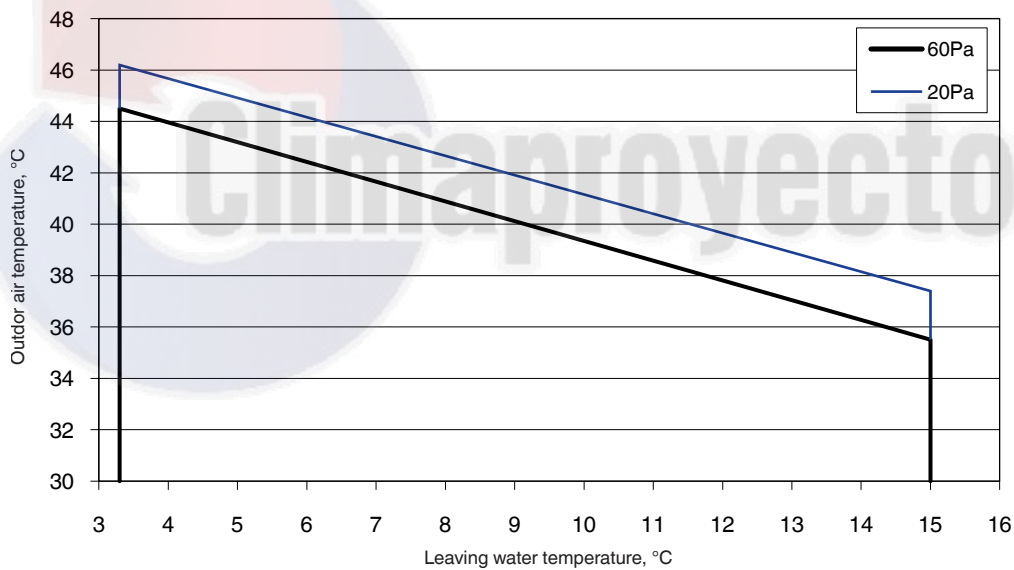

Physical data, sizes 252 to 852

30XA		252	302	352	402	452	504	502	602	702	752	802	854	852
Air conditioning application as per EN14511-3:2013[†] - standard unit and unit with option 279*														
Nominal cooling capacity	kW	267	291	318	378	426	-	473	601	654	691	759	-	807
ESEER	kW/kW	3.94	4.20	4.20	4.10	4.13	-	4.09	4.08	4.10	4.00	4.06	-	4.09
EER	kW/kW	3.00	2.96	2.98	3.08	2.89	-	2.93	3.03	3.11	2.91	2.88	-	2.98
Eurovent class cooling	B	B	B	B	B	C	-	B	B	A	B	C	-	B
Air conditioning application^{††} - standard unit														
Nominal cooling capacity	kW	267	291	319	379	427	-	475	603	656	693	761	-	809
ESEER	kW/kW	4.03	4.30	4.31	4.26	4.30	-	4.25	4.25	4.25	4.14	4.19	-	4.25
EER	kW/kW	3.02	2.98	3.01	3.12	2.92	-	2.97	3.07	3.15	2.94	2.91	-	3.01
Air conditioning application as per EN14511-3:2013[†] - unit with option 119														
Nominal cooling capacity	kW	273	298	325	391	442	498	499	612	679	723	785	824	841
ESEER	kW/kW	3.89	3.96	4.01	3.88	3.93	3.74	3.93	3.84	4.07	3.87	3.92	3.76	4.03
EER	kW/kW	3.13	3.10	3.09	3.21	3.08	3.07	3.15	3.13	3.31	3.08	3.10	3.10	3.24
Eurovent class cooling	A	A	B	A	B	B	A	A	A	B	A	A	A	A
Air conditioning application^{††} - standard unit + option 119*														
Nominal cooling capacity	kW	273	298	325	392	443	499	500	614	681	726	787	826	844
ESEER	kW/kW	3.97	4.04	4.10	4.03	4.08	3.85	4.08	4.00	4.22	4.01	4.05	3.88	4.18
EER	kW/kW	3.15	3.12	3.12	3.25	3.12	3.11	3.19	3.18	3.35	3.12	3.13	3.14	3.28
IPLV - standard unit	kW/kW	4.41	4.50	4.77	4.73	4.75	-	4.77	4.54	4.67	4.58	4.55	-	4.66
IPLV - unit with option 119*	kW/kW	4.31	4.37	4.56	4.38	4.51	4.33	4.51	4.35	4.64	4.40	4.47	4.41	4.55
Sound levels - Standard unit														
Sound power level ^{***}	dB(A)	99	99	99	98	101	-	98	100	98	103	102	-	100
Sound pressure level at 10 m ^{****}	dB(A)	67	67	67	65	69	-	65	67	65	70	70	-	67
Standard unit + option 279*														
Sound power level ^{***}	dB(A)	89	89	89	92	93	-	93	95	94	96	96	-	95
Sound pressure level at 10 m ^{****}	dB(A)	57	57	57	60	61	-	61	62	61	63	64	-	63
Standard unit + option 257*														
Sound power level ^{***}	dB(A)	87	87	87	90	91	-	91	93	92	94	94	-	94
Sound pressure level at 10 m ^{****}	dB(A)	55	55	55	58	59	-	59	60	59	61	61	-	61
Standard unit + option 258*														
Sound power level ^{***}	dB(A)	-	-	-	-	89	-	89	91	90	91	92	-	91
Sound pressure level at 10 m ^{****}	dB(A)	-	-	-	-	57	-	56	58	57	59	59	-	59
Standard unit + option 119*														
Sound power level ^{***}	dB(A)	100	100	100	100	102	100	100	102	100	104	104	102	102
Sound pressure level at 10 m ^{****}	dB(A)	68	68	68	68	70	68	68	69	68	71	71	70	69
Standard unit + option 119* + 279*														
Sound power level ^{***}	dB(A)	94	94	95	96	96	96	96	98	97	98	99	98	98
Sound pressure level at 10 m ^{****}	dB(A)	62	62	63	64	64	64	64	66	64	65	66	65	65
Dimensions - standard unit														
Length	mm	3604	3604	3604	4798	4798	4798	5992	7186	7186	7186	7186	7186	8380
Width	mm	2253	2253	2253	2253	2253	2253	2253	2253	2253	2253	2253	2253	2253
Height	mm	2297	2297	2297	2297	2297	2297	2297	2297	2297	2297	2297	2297	2297
Dimensions - standard unit + options 254/255*														
Length	mm	3604	3604	4798	4798	4798	-	5992	7186	7186	8380	8380	-	8380
Width	mm	2253	2253	2253	2253	2253	-	2253	2253	2253	2253	2253	-	2253
Height	mm	2297	2297	2297	2297	2297	-	2297	2297	2297	2297	2297	-	2297
Operating weight^{**}														
Standard unit + option 119*	kg	3410	3450	3490	4313	4883	4524	4814	5707	5857	6157	6457	6670	6958
Standard unit + option 254/255*	kg	3830	3860	4380	4830	4900	-	5470	6480	6640	7430	7750	-	7870
Compressors														
		06T semi-hermetic screw compressors, 50 r/s												
Circuit A + B		1 + 1	1 + 1	1 + 1	1 + 1	1 + 1	1 + 1	1 + 1	1 + 1	1 + 1	1 + 1	1 + 1	1 + 1	1 + 1
Circuit C + D		-	-	-	-	-	-	-	-	-	-	-	-	-
Refrigerant^{**} - Standard unit + option 119*														
Circuit A	kg	37	35	35	51	52	53.5	59	58	58	65	69	69	72
Circuit B	kg	39	36	37	37	37	32.5	36	59	62	58	65	65	63
Circuit C + D	kg	-	-	-	-	-	-	-	-	-	-	-	-	-
Standard unit + options 254/255*														
Circuit A	kg	60	64	70	85	85	-	102	102	100	129	112	-	130
Circuit B	kg	64	64	56	56	56	-	56	88	95	88	95	-	95
Circuit C + D	kg	-	-	-	-	-	-	-	-	-	-	-	-	-
Capacity control														
Minimum capacity	%	Touch Pilot, electronic expansion valve (EXV)												
		15	15	15	15	15	15	15	15	15	15	15	15	15
Condensers														
		All-aluminium micro-channel heat exchanger												
Fans														
Standard unit + option 119*														
Quantity		6	6	6	8	8	8	9	11	12	12	12	12	14
Total air flow	l/s	27083	27083	27083	36111	36111	36111	40625	49653	54167	54167	54167	54167	63194
Rotation speed	r/s	15.7	15.7	15.7	15.7	15.7	15.7	15.7	15.7	15.7	15.7	15.7	15.7	15.7
Fans - Standard unit + options 254/255*														
Quantity		6	6	7	8	8	-	9	11	12	13	13	-	14
Total air flow	l/s	20500	20500	20500	27333	27333	-	30750	37583	41000	41000	41000	-	47833
Rotation speed	r/s	11.7	11.7	11.7	11.7	11.7	-	11.7	11.7	11.7	11.7	11.7	-	11.7
Evaporator														
Water content	l	Flooded shell-and-tube type												
		58	61	61	66	70	77	77	79	94	98	119	119	119
Without hydronic module														
		Max. water-side pressure 1000 kPa, Victaulic water inlet and outlet connections												
Nominal diameter [†]	in	5	5	5	5	5	5	5	5	6	6	6	6	6
Actual outside diameter [†]	mm	141.3	141.3	141.3	141.3	141.3	141.3	141.3	141.3	168.3	168.3	168.3	168.3	168.3
With hydronic module (option 116)														
		Max. water-side pressure 400 kPa, nom. diameter 4", actual outside diameter 114.3 mm, Victaulic water inlet + outlet connections												
Expansion tank volume	l	50	50	50	50	50	-	80	-	-	-	-	-	-
Chassis paint colour Colour														
		Colour code: RAL7035												

† Eurovent-certified performances in accordance with standard EN14511-3:2013.

‡ Cooling mode conditions: evaporator water entering/leaving temperature 12°C/7°C, outside air temperature 35°C, evaporator fouling factor 0 m² K/W

†† Gross performances, not in accordance with EN14511-3:2013. These performances do not take into account the correction for the proportional heating capacity and power input generated by the water pump to overcome the internal pressure drop in the heat exchanger. Evaporator water entering/leaving temperature 12°C/7°C, outside air temperature 35°C, evaporator fouling factor 0 m² K/W

* Options: 119 = High energy efficiency, 257 = low noise level, 279 = compressor enclosure, 258 = very low sound level, 254 = traditional coils (Cu/Al), 255 = traditional coils (Cu/Al) without slots

** Weights are guidelines only. Refer to the unit nameplate.

*** in dB ref=10⁻¹² W, (A) weighting. Declared dualnumber noise emission values in accordance with ISO 4871 (with an associated uncertainty of +/-3dB(A)). Measured in accordance with ISO 9614-1 and certified by Eurovent.

**** in dB ref 20µPa, (A) weighting. Declared dualnumber noise emission values in accordance with ISO 4871 (with an associated uncertainty of +/-3dB(A)). For information, calculated from the sound power level Lw(A).

† Evaporator 1 and 2 connection diameters for sizes 1402 to 1502.

Notes:

1 Unit sizes 30XA 1402 to 1702 are supplied in two field-assembled modules.

2 Option 119 can be used with options 254 or 255. Contact your Carrier representative for the performances.



Eurovent certified values

Physical data, sizes 904 to 1702

30XA		904	902	1002	1112	1212	1312	1382	1402	1502	1702
Air conditioning application as per EN14511-3:2013[†] - standard unit and unit with option 279*											
Nominal cooling capacity	kW	-	875	960	1107	1218	1285	1377	1436	1443	1611
ESEER	kW/kW	-	3.81	3.82	3.82	3.99	3.82	3.45	3.95	3.85	3.81
EER	kW/kW	-	2.91	2.95	2.97	3.01	2.81	2.69	2.97	2.87	3.00
Eurovent class cooling		-	B	B	B	B	B	C	B	C	
Air conditioning application^{††}- standard unit											
Nominal cooling capacity	kW	-	878	962	1109	1220	1288	1380	1441	1447	1616
ESEER	kW/kW	-	3.93	3.93	3.89	4.08	3.59	3.53	4.10	4.00	3.97
EER	kW/kW	-	2.94	2.98	2.99	3.03	2.93	2.71	3.00	2.91	3.04
Air conditioning application as per EN14511-3:2013[†] - unit + option 119											
Nominal cooling capacity	kW	889	886	976	1144	1247	1326	1433	1480	1525	1682
ESEER	kW/kW	3.88	3.82	3.74	4.00	4.10	3.89	3.91	3.98	3.97	3.87
EER	kW/kW	3.10	3.12	3.09	3.27	3.23	3.16	3.06	3.20	3.19	3.22
Eurovent class cooling		A	A	B	A	A	A	B	A	A	A
Air conditioning application^{††}- standard unit + option 119*											
Nominal cooling capacity	kW	892	889	978	1146	1249	1329	1436	1485	1530	1688
ESEER	kW/kW	4.00	3.94	3.85	4.08	4.19	4	4.02	4.13	4.12	4.05
EER	kW/kW	3.14	3.15	3.13	3.3	3.25	3.19	3.09	3.24	3.23	3.27
IPLV - standard unit	kW/kW	-	4.35	4.39	4.28	4.51	3.83	3.87	4.57	4.43	4.33
IPLV - unit with option 119*	kW/kW	4.44	4.42	4.25	4.45	4.59	4.32	4.45	4.52	4.50	4.42
Sound levels - Standard unit											
Sound power level ^{***}	dB(A)	-	104	101	103	102	104	104	103	104	103
Sound pressure level at 10 m ^{****}	dB(A)	-	71	68	70	69	71	71	69	70	69
Standard unit + option 279*											
Sound power level ^{***}	dB(A)	-	97	96	97	96	100	97	97	97	97
Sound pressure level at 10 m ^{****}	dB(A)	-	64	63	64	63	67	64	64	64	64
Standard unit + option 257*											
Sound power level ^{***}	dB(A)	-	95	94	94	94	99	95	96	96	96
Sound pressure level at 10 m ^{****}	dB(A)	-	62	61	61	61	66	62	62	62	62
Standard unit + option 258*w											
Sound power level ^{***}	dB(A)	-	93	92	93	93	-	94	93	93	93
Sound pressure level at 10 m ^{****}	dB(A)	-	60	59	60	60	-	61	60	60	60
Standard unit + option 119*											
Sound power level ^{***}	dB(A)	105	105	103	104	103	105	105	105	105	105
Sound pressure level at 10 m ^{****}	dB(A)	72	72	70	71	70	72	72	72	72	71
Standard unit + option 119* + 279*											
Sound power level ^{***}	dB(A)	100	100	99	99	99	101	100	101	101	101
Sound pressure level at 10 m ^{****}	dB(A)	67	67	66	66	66	68	66	68	68	67
Dimensions - standard unit											
Length	mm	7186	8380	9574	11962	11962	11962	11962	9574/4798	9574/4798	8380/8380
Width	mm	2253	2253	2253	2253	2253	2253	2253	2253	2253	2253
Height	mm	2297	2297	2297	2297	2297	2297	2297	2297	2297	2297
Dimensions - standard unit + options 254/255*											
Length	mm	-	9574	9574	11962	11962	11962	11962	9574/4798	9574/4798	8380/8380
Width	mm	-	2253	2253	2253	2253	2253	2253	2253	2253	2253
Height	mm	-	2297	2297	2297	2297	2297	2297	2297	2297	2297
Operating weight^{**}											
Standard unit + option 119*	kg	6920	7258	7836	8210	8590	9310	9390	3953/ 7776	3953/ 7926	6958/ 6958
Standard unit + option 254/255*	kg	-	8620	8870	8920	9330	10050	10140	4460/8830	4460/8950	7880/7880
Compressors											
06T semi-hermetic screw compressors, 50 r/s											
Circuit A + B		1 + 1	1 + 1	1 + 1	1 + 1	1 + 1	1 + 1	1 + 1	1 + 1	1 + 1	1 + 1
Circuit C + D		-	-	-	-	-	-	-	1 + 0	1 + 0	1 + 1
Refrigerant^{**} - Standard unit + option 119*											
R-134a											
Circuit A + B	kg	67/67	69/76	75/79	80/116	80/124	110/116	116/124	84/78	85/88	72/63
Circuit C + D	kg	-	-	-	-	-	-	-	80/-	80/-	72/63
Standard unit + options 254/255*											
Circuit A + B	kg	-	129+103	140/129	-	-	-	-	140/103	140/129	130/95
Circuit C + D	kg	-	-	-	-	-	-	-	135/-	135/-	130/95
Capacity control											
Touch Pilot, electronic expansion valve (EXV), minimum capacity 15%											
Minimum capacity	%	15	15	15	8	8	8	8	10	10	8
Condensers											
All-aluminium micro-channel heat exchanger											
Fans											
Axial Flying Bird 4, rotating shroud											
Standard unit + option 119*											
Quantity		12	14	16	19	20	20	20	24	24	28
Total air flow	l/s	54167	63194	72222	85764	90278	90278	90278	108333	108333	126389
Rotation speed	r/s	15.7	15.7	15.7	15.7	15.7	15.7	15.7	15.7	15.7	15.7
Fans - Standard unit + options 254/255*											
Quantity		-	15	16	19	20	20	20	24	24	28
Total air flow	l/s	-	47833	54667	64917	68333	68333	68333	82000	82000	95667
Rotation speed	r/s	-	11.7	11.7	11.7	11.7	11.7	11.7	11.7	11.7	11.7
Evaporator											
Flooded shell-and-tube type											
Water content	l	130	130	140	164	174	180	180	230	240	240
Without hydronic module											
Max. water-side pressure 1000 kPa, Victaulic water inlet and outlet connections											
Nominal diameter [†]	in	6	6	8	6	6	6	6	8/6	8/6	6
Actual outside diameter [‡]	mm	168.3	168.3	219.1	168.3	168.3	168.3	168.3	219.1/ 168.3	219.1/ 168.3	168.3
Chassis paint colour Colour											
Colour code: RAL7035											
Chassis paint colour Colour											
Colour code: RAL7035											

† Eurovent-certified performances in accordance with standard EN14511-3:2013.

Cooling mode conditions: evaporator water entering/leaving temperature 12°C/7°C, outside air temperature 35°C. evaporator fouling factor 0 m2 K/W

†† Gross performances, not in accordance with EN14511-3:2013. These performances do not take into account the correction for the proportional heating capacity and power input generated by the water pump to overcome the internal pressure drop in the heat exchanger. Evaporator water entering/leaving temperature 12°C/7°C, outside air temperature 35°C. evaporator fouling factor 0 m2 K/W

* Options: 119 = High energy efficiency, 257 = low noise level, 279 = compressor enclosure, 258, = very low sound level, 254 = traditional coils (Cu/Al), 255 = traditional coils (Cu/Al) without slots

** Weights are guidelines only. Refer to the unit nameplate.

*** in dB ref=10⁻¹² W, (A) weighting. Declared dualnumber noise emission values in accordance with ISO 4871 (with an associated uncertainty of +/-3dB(A)). Measured in accordance with ISO 9614-1 and certified by Eurovent.

**** in dB ref 20µPa, (A) weighting. Declared dualnumber noise emission values in accordance with ISO 4871 (with an associated uncertainty of +/-3dB(A)). For information, calculated from the sound power level Lw(A).

‡ Evaporator 1 and 2 connection diameters for sizes 1402 to 1502.

Notes:

1 Unit sizes 30XA 1402 to 1702 are supplied in two field-assembled modules.

2 Option 119 can be used with options 254 or 255. Contact your Carrier representative for the performances.



Eurovent certified values

Electrical data, sizes 252 to 852

Standard unit or with option 81

30XA		252	302	352	402	452	502	602	702	752	802	852
Power circuit												
Nominal power supply	V-ph-Hz	400-3-50 ± 10%										
Control circuit												
24 V via internal transformer												
Maximum start-up current*												
Circuit 1**	A	269	269	287	402	505	505	574	606	773	803	805
Circuit 2**	A	-	-	-	-	-	-	-	-	-	-	-
Option 81	A	-	-	-	-	-	-	-	-	-	-	-
Nominal start-up current***												
Circuit 1**	A	245	245	262	378	480	480	536	562	735	759	761
Circuit 2**	A	-	-	-	-	-	-	-	-	-	-	-
Option 81	A	-	-	-	-	-	-	-	-	-	-	-
Cosine Phi (maximum)****												
0.88												
Cosine Phi (nominal)†												
0.85												
Maximum power input‡												
Circuit 1**	kW	121	131	141	165	185	204	247	267	293	312	343
Circuit 2**	kW	-	-	-	-	-	-	-	-	-	-	-
Option 81	kW	-	-	-	-	-	-	-	-	-	-	-
Nominal unit current draw†												
Circuit 1**	A	151	167	184	210	242	268	325	352	408	433	453
Circuit 2**	A	-	-	-	-	-	-	-	-	-	-	-
Option 81	A	-	-	-	-	-	-	-	-	-	-	-
Maximum unit current draw (Un)‡												
Circuit 1**	A	198	215	233	270	303	335	404	436	492	522	572
Circuit 2**	A	-	-	-	-	-	-	-	-	-	-	-
Option 81	A	-	-	-	-	-	-	-	-	-	-	-
Option 231		182	196	211	242	272	305	364	397	448	479	531
Maximum unit current draw (Un – 10%)****												
Circuit 1**	A	208	232	251	290	326	360	435	469	529	561	615
Circuit 2**	A	-	-	-	-	-	-	-	-	-	-	-
Option 81	A	-	-	-	-	-	-	-	-	-	-	-

Unit with option 119 or with option 119 and option 81

30XA		252	302	352	402	452	504	502	602	702	752	802	854	852
Power circuit														
Nominal power supply	V-ph-Hz	400-3-50 ± 10%												
Control circuit														
24 V via internal transformer														
Maximum start-up current*														
Circuit 1**	A	274	274	292	407	510	510	510	583	616	782	812	812	815
Circuit 2**	A	-	-	-	-	-	-	-	-	-	-	-	-	-
Option 81	A	-	-	-	-	-	-	-	-	-	-	-	-	-
Nominal start-up current***														
Circuit 1**	A	246	246	261	379	479	479	479	535	561	734	757	760	760
Circuit 2**	A	-	-	-	-	-	-	-	-	-	-	-	-	-
Option 81	A	-	-	-	-	-	-	-	-	-	-	-	-	-
Cosine Phi (maximum)****														
0.88														
Cosine Phi (nominal)†														
0.84														
Maximum power input‡														
Circuit 1**	kW	126	136	147	172	192	211	212	257	278	304	323	353	356
Circuit 2**	kW	-	-	-	-	-	-	-	-	-	-	-	-	-
Option 81	kW	-	-	-	-	-	-	-	-	-	-	-	-	-
Nominal unit current draw†														
Circuit 1**	A	151	167	182	210	239	267	267	324	349	409	430	446	446
Circuit 2**	A	-	-	-	-	-	-	-	-	-	-	-	-	-
Option 81	A	-	-	-	-	-	-	-	-	-	-	-	-	-
Maximum unit current draw (Un)‡														
Circuit 1**	A	208	226	243	284	316	347	350	423	457	512	542	590	596
Circuit 2**	A	-	-	-	-	-	-	-	-	-	-	-	-	-
Option 81	A	-	-	-	-	-	-	-	-	-	-	-	-	-
Option 231		192	207	221	256	285	317	320	383	418	468	499	549	555
Maximum unit current draw (Un – 10%)****														
Circuit 1**	A	219	243	262	305	340	373	376	455	491	551	583	634	640
Circuit 2**	A	-	-	-	-	-	-	-	-	-	-	-	-	-
Option 81	A	-	-	-	-	-	-	-	-	-	-	-	-	-

* Instantaneous start-up current (operating current of the smallest compressor + fan current + locked rotor current in star connection of the largest compressor). Values obtained at operation with maximum unit power input.

** 30XA 1402 to 1702 units: circuit 1 supplies circuits A and B, circuit 2 supplies circuits C and D. 30XA 1112, 1212, 1312 and 1382 units: circuit 1 supplies circuit A, circuit 2 supplies circuit B.

*** Instantaneous start-up current (operating current of the smallest compressor + fan current + locked rotor current in star connection of the largest compressor). Values obtained at standard Eurovent unit operating conditions: air 35 °C, water 12/7 °C.

**** Values obtained at operation with maximum unit power input.

† Values obtained at standard Eurovent unit operating conditions: air 35 °C, water 12/7 °C

‡ Values obtained at operation with maximum unit power input. Values given on the unit name plate

Notes:

- Unit sizes 30XA 1112, 1212, 1312, 1382, 1402 to 1702 have two power connection points.

Electrical data, sizes 904 to 1702

Standard unit or with option 81											
30XA		902	1002	1112	1212	1312	1382	1402	1502	1702	
Power circuit											
Nominal power supply	V-ph-Hz	400-3-50 ± 10%									
Control circuit											
24 V via internal transformer											
Maximum start-up current**											
Circuit 1**	A	893	941	587	587	772	772	893	941	805	
Circuit 2**	A	-	-	772	772	772	772	587	587	805	
Option 81	A	-	-	1085	1131	1198	1228	1248	1294	-	
Nominal start-up current***											
Circuit 1**	A	845	865	587	587	772	772	845	865	761	
Circuit 2**	A	-	-	772	772	772	772	587	587	761	
Option 81	A	-	-	1023	1039	1103	1118	1125	1143	-	
Cosine Phi (maximum)****											
0.86											
Cosine Phi (nominal)†											
0.85											
Maximum power input‡											
Circuit 1**	kW	359	420	182	211	258	278	390	420	343	
Circuit 2**	kW	-	-	279	302	278	299	210	210	343	
Option 81	kW	-	-	400	512	531	571	600	630	-	
Nominal unit current draw†											
Circuit 1**	A	508	548	258	274	340	356	530	556	452	
Circuit 2**	A	-	-	358	392	356	387	278	278	452	
Option 81	A	-	-	616	666	696	743	808	834	-	
Maximum unit current draw (Un)‡											
Circuit 1**	A	611	707	313	359	426	456	661	707	572	
Circuit 2**	A	-	-	459	496	456	491	354	354	572	
Option 81	A	-	-	771	855	882	947	1015	1061	-	
Option 231		855	662	-	-	-	-	-	-	-	
Maximum unit current draw (Un – 10%)****											
Circuit 1**	A	657	760	332	381	462	494	711	760	615	
Circuit 2**	A	-	-	497	527	494	522	380	380	615	
Option 81	A	-	-	828	908	956	1016	1091	1141	-	
Unit with option 119 or with option 119 and option 81											
30XA		904	902	1002	1112	1212	1312	1382	1402	1502	1702
Power circuit											
Nominal power supply	V-ph-Hz	400-3-50 ± 10%									
Control circuit											
24 V via internal transformer											
Maximum start-up current**											
Circuit 1**	A	902	905	954	587	587	772	772	905	954	815
Circuit 2**	A	-	-	-	772	772	772	772	587	587	815
Option 81	A	-	-	-	1093	1139	1208	1238	1275	1321	-
Nominal start-up current***											
Circuit 1**	A	843	845	860	587	587	772	772	845	860	760
Circuit 2**	A	-	-	-	772	772	772	772	587	587	760
Option 81	A	-	-	-	1031	1047	1113	1128	1122	1133	-
Cosine Phi (maximum)****											
0.85											
Cosine Phi (nominal)†											
0.84											
Maximum power input‡											
Circuit 1**	kW	369	372	435	186	216	262	284	405	435	356
Circuit 2**	kW	-	-	-	286	309	284	305	217	217	356
Option 81	kW	-	-	-	471	525	544	584	622	652	-
Nominal unit current draw†											
Circuit 1**	A	511	511	541	259	275	341	356	527	546	446
Circuit 2**	A	-	-	-	360	393	356	386	273	273	446
Option 81	A	-	-	-	619	668	697	742	800	820	-
Maximum unit current draw (Un)‡											
Circuit 1**	A	629	635	734	321	367	436	466	688	734	596
Circuit 2**	A	-	-	-	470	508	466	501	367	367	596
Option 81	A	-	-	-	790	875	902	967	1056	1102	-
Option 231		582	588	689	-	-	-	-	-	-	-
Maximum unit current draw (Un – 10%)****											
Circuit 1**	A	677	683	790	340	389	472	504	740	790	640
Circuit 2**	A	-	-	-	508	539	504	532	395	395	640
Option 81	A	-	-	-	847	928	976	1036	1135	1185	-

* Instantaneous start-up current (operating current of the smallest compressor + fan current + locked rotor current in star connection of the largest compressor). Values obtained at operation with maximum unit power input.

** 30XA 1402 to 1702 units: circuit 1 supplies circuits A and B, circuit 2 supplies circuits C and D. 30XA 1112, 1212, 1312 and 1382 units: circuit 1 supplies circuit A, circuit 2 supplies circuit B.

*** Instantaneous start-up current (operating current of the smallest compressor + fan current + locked rotor current in star connection of the largest compressor). Values obtained at standard Eurovent unit operating conditions: air 35 °C, water 12/7 °C

**** Values obtained at operation with maximum unit power input.

† Values obtained at standard Eurovent unit operating conditions: air 35 °C, water 12/7 °C

‡ Values obtained at operation with maximum unit power input. Values given on the unit name plate

Notes:

- Unit sizes 30XA 1112, 1212, 1312, 1382, 1402 to 1702 have two power connection points.

Part load performances

With the rapid increase in energy costs and the care about environmental impacts of electricity production, power consumption of air conditioning equipment has become an important topic. The energy efficiency of a liquid chiller at full load is rarely representative of the actual performance of the units, as on average a chiller works less than 5% of the time at full load.

The heat load of a building depends on many factors, such as the outside air temperature, the exposure to the sun and the building occupancy.

Consequently it is preferable to use the average energy efficiency, calculated at several operating points that are representative for the unit utilisation.

IPLV (in accordance with AHRI 550/590)

The IPLV (integrated part load value) allows evaluation of the average energy efficiency based on four operating conditions defined by the AHRI (Air Conditioning, Heating and Refrigeration Institute). The IPLV is the average weighted value of the energy efficiency ratios (EER) at different operating conditions, weighted by the operating time.

ESEER (in accordance with EUROVENT)

The ESEER (European seasonal energy efficiency ratio) permits evaluation of the average energy efficiency at part load, based on four operating conditions defined by Eurovent. The ESEER is the average value of energy efficiency ratios (EER) at different operating conditions, weighted by the operating time.

IPLV (integrated part load value)

Load %	Air temperature °C	Energy efficiency	Operating time %
100	35	EER ₁	1
75	26.7	EER ₂	42
50	18.3	EER ₃	45
25	12.8	EER ₄	12
ESEER = EER ₁ x 1% + EER ₂ x 42% + EER ₃ x 45% + EER ₄ x 12%			

Note: Constant leaving water temperature 6.67 °C (44°F).

ESEER (European seasonal energy efficiency ratio)

Load %	Air temperature °C	Energy efficiency	Operating time %
100	35	EER ₁	3
75	30	EER ₂	33
50	25	EER ₃	41
25	20	EER ₄	23
ESEER = EER ₁ x 3% + EER ₂ x 33% + EER ₃ x 41% + EER ₄ x 23%			

Note: Constant leaving water temperature 7 °C.

30XA	252	302	352	402	452	504	502	602	702	752	802	854	852	904	902	1002	1112	1212	1312	1382	1402	1502	1702	
Standard unit																								
IPLV	kW/kW	4.41	4.50	4.77	4.73	4.75	-	4.77	4.54	4.67	4.58	4.55	-	4.66	-	4.35	4.39	4.28	4.51	3.83	3.87	4.57	4.43	4.33
ESEER	kW/kW	3.94	4.20	4.20	4.10	4.13	-	4.09	4.08	4.10	4.00	4.06	-	4.09	-	3.81	3.82	3.82	3.99	3.50	3.45	3.95	3.85	3.81
High-efficiency unit (option 119)																								
IPLV	kW/kW	4.31	4.37	4.56	4.38	4.51	4.33	4.51	4.35	4.64	4.40	4.47	4.41	4.55	4.44	4.32	4.25	4.45	4.59	4.32	4.45	4.52	4.50	4.42
ESEER	kW/kW	3.89	3.96	4.01	3.88	3.93	3.74	3.93	3.84	4.07	3.87	3.92	3.76	4.03	3.88	3.82	3.74	4.00	4.10	3.89	3.91	3.98	3.97	3.87

ESEER Calculations according to standard performances (in accordance with EN14511-3:2013) and certified by Eurovent.

IPLV Calculations according to standard performances (in accordance with AHRI 550-590)

Electrical data notes and operating conditions for 30XA units:

- 30XA 252-1002 units have a single power connection point; 30XA 1112, 1212, 1312, 1382, 1402 to 1702 units have two connection points.
 - The control box includes the following standard features:
 - One general disconnect switch per circuit
 - Starter and motor protection devices for each compressor, the fan(s) and the pump
 - Control devices
 - Field connections:**
 - All connections to the system and the electrical installations must be in full accordance with all applicable local codes.
 - The Carrier 30XA units are designed and built to ensure conformance with these codes. The recommendations of European standard EN 60204-1 (corresponds to IEC 60204-1) (machine safety - electrical machine components - part 1: General regulations) are specifically taken into account, when designing the electrical equipment.
 - IMPORTANT:**
 - Generally the recommendations of IEC 60364 are accepted as compliance with the requirements of the installation regulations.
 - Conformance with EN 60204 is the best means of ensuring compliance with the Machines Directive § 1.5.1. Annex B of EN 60204-1 describes the electrical characteristics used for the operation of the machines.
 - 1. Environment* - Environment as classified in EN 60364 (corresponds to IEC 60364):
 - Outdoor installation*
 - Ambient temperature range: from -20°C to +55°C**
 - Altitude less than or equal to 2000 m (for hydronic module, see paragraph 4.7 in the IOM)
 - Presence of hard solids, class AE3 (no significant dust present)*
 - Presence of corrosive and polluting substances, class AF1 (negligible)
 - Competence of persons: BA4 (Persons wise); 30XA machines are not intended to be installed in locations open to anyone, including people with disabilities and children.
 - 2. Compatibility for low-frequency conducted disturbances according to IEC61000-2-2 and to class 2 levels per IEC61000-2-4 standard:
 - Power supply frequency variation : +2Hz
 - Phase imbalance : 2%
 - Total Voltage Harmonic Distortion (THDV) : 8%
 - 3. The neutral (N) line must not be connected directly to the unit (if necessary use a transformer).
 - 4. Overcurrent protection of the power supply conductors is not provided with the unit.
 - 5. The factory-installed disconnect switch(es)/circuit breaker(s) is (are) of a type suitable for power interruption in accordance with EN 60947-3 (corresponds to IEC 60947-3).
 - 6. The units are designed for simplified connection on TN(s) networks (IEC 60364). For IT networks provide a local earth and consult competent local organisations to complete the electrical installation. Units delivered with speed drive (options 28) are not compatible with IT network.
 - Derived currents: If protection by monitoring of derived currents is necessary to ensure the safety of the installation, the control of the cut-out value must take the presence of leak currents into consideration that result from the use of optional frequency converters in the unit. In particular, a type of enhanced immunity protection and/or a value of at least 150 mA is recommended to control differential protection devices.
 - Capacitors that are integrated as part of the option 231 can generate electrical disturbances in the installation the unit is connected to. Presence of these capacitors must be considered during the electrical study prior to the start-up.
- NOTE: If particular aspects of an actual installation do not conform to the conditions described above, or if there are other conditions which should be considered, always contact your local Carrier representative.**
- * The required protection level for this class is IP43BW (according to reference document IEC 60529). All 30XA units are protected to IP44CW and fulfill this protection condition.
- ** The maximum ambient temperature allowed for machines equipped with option 231 is +40°C

Sound spectrum

30XA - standard unit

		Octave bands, Hz						Sound power level
		125	250	500	1k	2k	4k	
252	dB	91	95	86	98	84	76	dB(A) 99
302	dB	91	95	86	98	84	76	dB(A) 99
352	dB	91	95	86	98	84	77	dB(A) 99
402	dB	90	94	91	96	89	83	dB(A) 98
452	dB	104	107	93	96	88	83	dB(A) 101
504	dB	-	-	-	-	-	-	dB(A) -
502	dB	91	93	93	94	91	85	dB(A) 98
602	dB	102	105	94	94	89	84	dB(A) 100
702	dB	91	93	93	94	91	85	dB(A) 98
752	dB	104	108	96	99	90	86	dB(A) 103
802	dB	95	101	96	100	92	87	dB(A) 102
854	dB	-	-	-	-	-	-	dB(A) -
852	dB	95	98	95	96	91	88	dB(A) 100
904	dB	-	-	-	-	-	-	dB(A) -
902	dB	96	104	96	102	90	86	dB(A) 104
1002	dB	98	101	96	98	88	90	dB(A) 101
1112	dB	97	103	101	100	93	88	dB(A) 103
1212	dB	97	103	98	98	93	88	dB(A) 102
1312	dB	97	103	103	101	93	88	dB(A) 104
1382	dB	97	103	103	101	93	88	dB(A) 104
1402	dB	100	103	98	99	90	92	dB(A) 103
1502	dB	99	104	98	101	91	91	dB(A) 104
1702	dB	98	101	98	100	94	91	dB(A) 103

30XA - unit with option 119*

		Octave bands, Hz						Sound power level
		125	250	500	1k	2k	4k	
252	dB	97	96	93	99	87	82	dB(A) 100
302	dB	97	96	93	99	87	82	dB(A) 100
352	dB	98	96	93	99	87	82	dB(A) 100
402	dB	98	97	95	99	89	84	dB(A) 100
452	dB	105	107	96	97	89	85	dB(A) 102
504	dB	97	96	96	97	92	87	dB(A) 100
502	dB	97	96	96	97	92	87	dB(A) 100
602	dB	104	106	97	96	91	87	dB(A) 102
702	dB	98	96	96	97	92	87	dB(A) 100
752	dB	105	108	98	100	91	87	dB(A) 104
802	dB	101	102	99	101	93	89	dB(A) 104
854	dB	100	99	98	98	92	89	dB(A) 102
852	dB	100	99	98	98	92	89	dB(A) 102
904	dB	101	104	99	103	92	88	dB(A) 105
902	dB	101	104	99	103	92	88	dB(A) 105
1002	dB	102	102	99	100	91	91	dB(A) 103
1112	dB	102	104	99	99	94	90	dB(A) 104
1212	dB	102	104	100	99	95	89	dB(A) 103
1312	dB	103	104	103	102	95	89	dB(A) 105
1382	dB	102	104	103	102	95	89	dB(A) 105
1402	dB	105	105	102	102	94	94	dB(A) 105
1502	dB	104	104	101	103	93	92	dB(A) 105
1702	dB	103	102	101	101	95	92	dB(A) 105

30XA - unit with option 279*

		Octave bands, Hz						Sound power level
		125	250	500	1k	2k	4k	
252	dB	89	93	83	86	76	67	dB(A) 89
302	dB	89	93	83	86	76	67	dB(A) 89
352	dB	89	93	83	86	76	67	dB(A) 89
402	dB	89	94	90	86	83	73	dB(A) 92
452	dB	100	98	88	86	79	72	dB(A) 93
504	dB	-	-	-	-	-	-	dB(A) -
502	dB	100	98	88	86	79	72	dB(A) 93
602	dB	101	100	91	88	83	77	dB(A) 95
702	dB	93	95	92	89	85	79	dB(A) 94
752	dB	101	99	91	92	82	75	dB(A) 96
802	dB	101	100	91	92	82	76	dB(A) 96
854	dB	-	-	-	-	-	-	dB(A) -
852	dB	96	96	93	91	85	80	dB(A) 95
904	dB	-	-	-	-	-	-	dB(A) -
902	dB	94	97	92	95	83	77	dB(A) 97
1002	dB	97	96	93	92	84	81	dB(A) 96
1112	dB	102	100	93	91	85	79	dB(A) 96
1212	dB	97	96	92	91	88	87	dB(A) 96
1312	dB	97	98	101	93	90	87	dB(A) 100
1382	dB	97	96	94	92	90	87	dB(A) 97
1402	dB	98	98	94	94	85	83	dB(A) 97
1502	dB	97	97	93	95	84	81	dB(A) 97
1702	dB	98	98	95	93	87	83	dB(A) 97

30XA - unit with options 119 + 279*

		Octave bands, Hz						Sound power level
		125	250	500	1k	2k	4k	
252	dB	96	95	91	91	84	79	dB(A) 94
302	dB	96	95	91	91	84	79	dB(A) 94
352	dB	96	95	92	91	84	79	dB(A) 95
402	dB	97	96	93	92	86	81	dB(A) 96
452	dB	97	95	93	92	87	81	dB(A) 96
504	dB	97	95	94	92	87	82	dB(A) 96
502	dB	97	95	94	92	87	82	dB(A) 96
602	dB	97	98	95	94	90	83	dB(A) 98
702	dB	98	96	95	93	87	82	dB(A) 97
752	dB	102	100	95	95	87	82	dB(A) 98
802	dB	99	97	96	96	88	83	dB(A) 99
854	dB	100	97	96	95	88	84	dB(A) 98
852	dB	100	97	96	95	88	84	dB(A) 98
904	dB	100	98	96	97	88	83	dB(A) 100
902	dB	100	98	96	97	88	83	dB(A) 100
1002	dB	100	97	96	95	88	84	dB(A) 99
1112	dB	103	100	96	95	89	84	dB(A) 99
1212	dB	102	99	96	92	91	88	dB(A) 99
1312	dB	103	100	100	96	93	89	dB(A) 101
1382	dB	102	100	97	94	91	88	dB(A) 100
1402	dB	103	100	99	98	91	87	dB(A) 101
1502	dB	102	99	98	98	90	86	dB(A) 101
1702	dB	103	100	99	98	91	87	dB(A) 101

* Options: 119 = high energy efficiency, 279 = compressor enclosure

Sound spectrum (continued)

30XA - Unit with option 257*

		Octave bands, Hz						Sound power level	
		125	250	500	1 k	2 k	4k		
252	dB	88	89	83	84	76	68	dB(A)	87
302	dB	88	89	83	84	76	68	dB(A)	87
352	dB	88	89	83	84	76	68	dB(A)	87
402	dB	89	92	87	86	80	71	dB(A)	90
452	dB	90	96	87	86	80	69	dB(A)	91
504	dB	-	-	-	-	-	-	dB(A)	-
502	dB	92	94	89	87	81	72	dB(A)	91
602	dB	90	96	91	88	81	77	dB(A)	93
702	dB	92	94	90	87	82	73	dB(A)	92
752	dB	91	97	91	89	80	70	dB(A)	94
802	dB	92	94	92	90	81	72	dB(A)	94
854	dB	-	-	-	-	-	-	dB(A)	-
852	dB	96	96	92	89	81	74	dB(A)	94
904	dB	-	-	-	-	-	-	dB(A)	-
902	dB	93	94	94	92	80	71	dB(A)	95
1002	dB	97	96	93	89	79	75	dB(A)	94
1112	dB	95	98	92	89	82	74	dB(A)	95
1212	dB	97	95	91	88	86	85	dB(A)	94
1312	dB	97	98	99	93	90	87	dB(A)	99
1382	dB	97	95	92	90	88	86	dB(A)	95
1402	dB	99	96	94	91	81	75	dB(A)	96
1502	dB	100	97	95	91	81	77	dB(A)	96
1702	dB	98	98	94	91	83	76	dB(A)	96

30XA - Unit with options 119 + 257*

		Octave bands, Hz						Sound power level	
		125	250	500	1k	2k	4k		
252	dB	95	92	90	90	83	78	dB(A)	93
302	dB	95	92	90	90	83	78	dB(A)	93
352	dB	95	92	90	90	83	78	dB(A)	93
402	dB	96	94	93	91	85	80	dB(A)	95
452	dB	96	97	92	91	85	79	dB(A)	95
504	dB	96	94	92	91	85	80	dB(A)	95
502	dB	96	94	92	91	85	80	dB(A)	95
602	dB	97	97	96	94	86	82	dB(A)	98
702	dB	97	95	94	92	86	81	dB(A)	96
752	dB	97	97	95	93	86	81	dB(A)	97
802	dB	98	95	95	94	86	81	dB(A)	97
854	dB	99	96	95	93	86	82	dB(A)	97
852	dB	99	96	95	93	86	82	dB(A)	97
904	dB	98	96	96	95	87	82	dB(A)	98
902	dB	98	96	96	95	87	82	dB(A)	98
1002	dB	100	97	96	94	87	83	dB(A)	98
1112	dB	100	99	97	95	88	83	dB(A)	99
1212	dB	102	99	95	92	91	88	dB(A)	98
1312	dB	103	100	100	96	93	89	dB(A)	101
1382	dB	102	99	96	92	91	88	dB(A)	99
1402	dB	102	99	98	96	89	84	dB(A)	100
1502	dB	102	99	98	96	89	85	dB(A)	100
1702	dB	102	99	98	96	89	85	dB(A)	100

30XA - Unit with option 258*

		Octave bands, Hz						Sound power level	
		125	250	500	1 k	2 k	4k		
252	dB	-	-	-	-	-	-	dB(A)	-
302	dB	-	-	-	-	-	-	dB(A)	-
352	dB	-	-	-	-	-	-	dB(A)	-
402	dB	-	-	-	-	-	-	dB(A)	-
452	dB	89	93	84	85	76	67	dB(A)	89
504	dB	-	-	-	-	-	-	dB(A)	-
502	dB	90	92	85	85	77	70	dB(A)	89
602	dB	91	93	88	87	79	77	dB(A)	91
702	dB	92	92	87	85	79	73	dB(A)	90
752	dB	92	94	89	87	79	73	dB(A)	91
802	dB	93	92	90	88	80	75	dB(A)	92
854	dB	-	-	-	-	-	-	dB(A)	-
852	dB	93	92	90	87	79	74	dB(A)	91
904	dB	-	-	-	-	-	-	dB(A)	-
902	dB	94	92	91	89	80	76	dB(A)	93
1002	dB	94	91	91	87	79	75	dB(A)	92
1112	dB	94	95	91	88	80	74	dB(A)	92
1212	dB	97	93	90	87	85	84	dB(A)	93
1312	dB	-	-	-	-	-	-	dB(A)	-
1382	dB	97	95	91	88	86	85	dB(A)	94
1402	dB	95	93	93	89	80	76	dB(A)	93
1502	dB	95	93	93	89	80	76	dB(A)	93
1702	dB	95	94	92	89	81	76	dB(A)	93

* Options: 119 = high energy efficiency, 257 = low noise level, 258 = very low noise level

Operating limits

Evaporator water temperature, °C	Minimum	Maximum
Water entering temperature at start-up	-	45*
Water entering temperature during operation	6.8	21
Water leaving temperature during operation	3.3	15

Note: If the leaving water temperature is below 4 °C, a glycol/water solution or the frost protection option must be used.

Condenser air temperature, °C	Minimum	Maximum
Storage	-20	68
Operation:		
Standard unit	-10	55**
With winter operation option (option 28)	-20	55**
With high energy efficiency option (option 119)***	-10	55****

Note: If the air temperature is below 0 °C, a glycol/water solution or the frost protection option must be used.

* Based on the installation type and the air temperature

** Part load, based on the water temperature

*** Recommended for operation above 46 °C

**** Part-load operation

Evaporator water flow rate (l/s)*	Minimum	Maximum**
30XA		
252	3.6	37.5
302	4.0	40.5
352	4.3	40.5
402	5.3	34.1
452	6.0	36.9
504	6.7	42
502	6.7	42.0
602	8.1	45.0
702	8.9	56.1
752	9.6	59.1
802	10.4	67.1
854	11	67.1
852	11.0	67.1
904	11.8	73.9
902	11.8	73.9
1002	13.1	83.9
1112	15.1	126.5
1212	16.4	132.1
1312	17.5	118.5
1382	18.8	131.1
1402	19.3	107.4
1502	19.9	109.4
1702	22.0	107.4

* Standard evaporators with water as the heat transfer fluid.

** The maximum water flow rate corresponds to a pressure drop of 100 kPa.

Operating range

30XA standard unit and 30XA504, 854, 904 with option 119

30XA high-energy efficiency unit or unit with option 119

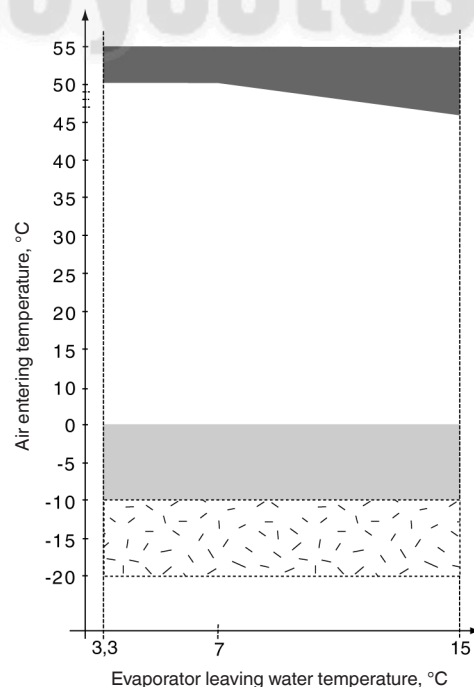
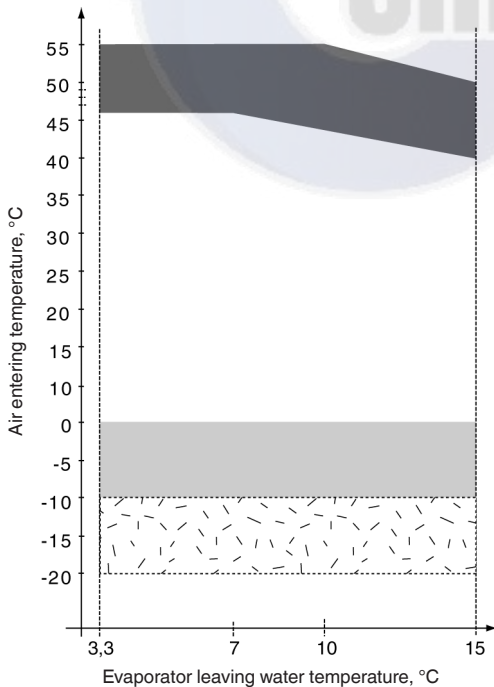

Legend

 Operating range, unit equipped with option 28 (winter operation)

 Below 0 °C air temperature the unit must either be equipped with the evaporator frost protection option (41A or 41B), or the water loop must be protected against frost by using a frost protection solution (by the installer).

 Part load average

Dimensions/clearances

30XA 252-352 - MCHE heat exchanger (standard)
30XA 252-302 - Cu/Al heat exchanger (option 254/255)

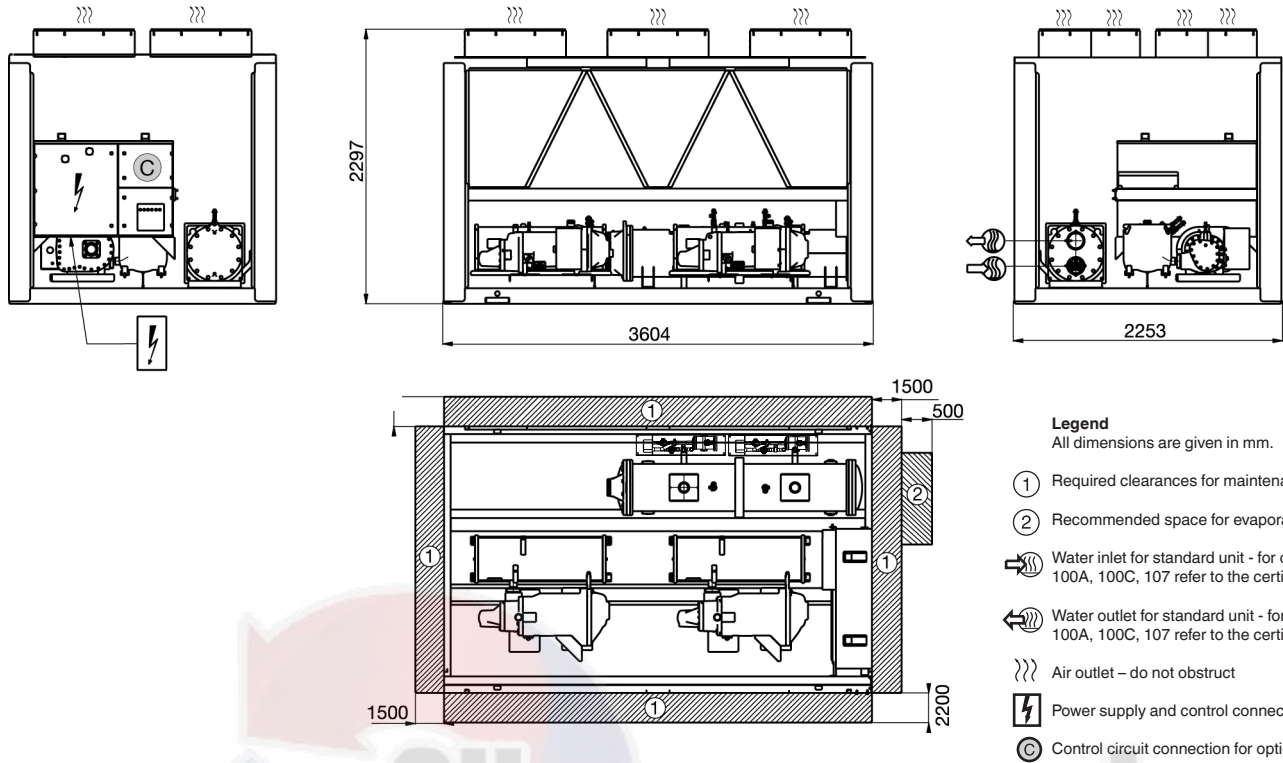

30XA 402-452-504 - MCHE heat exchanger (standard)
30XA 352-452 - Cu/Al heat exchanger (option 254/255)

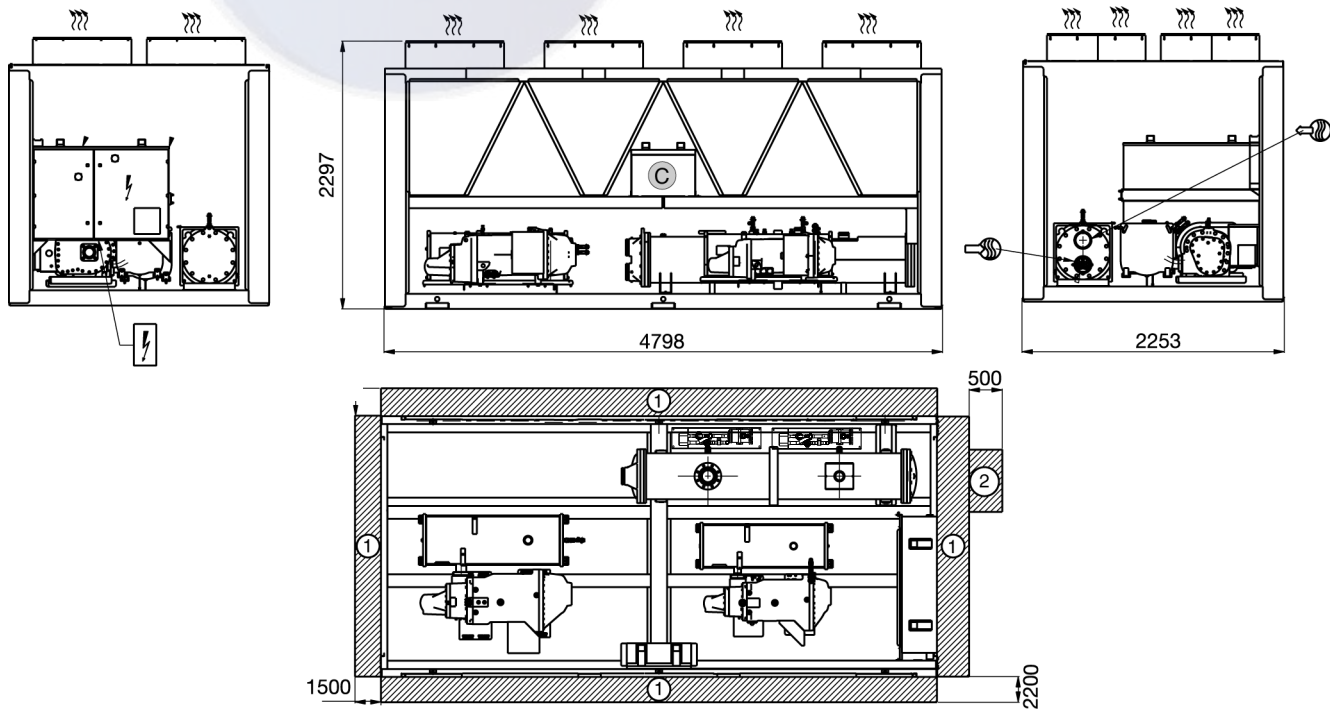

NOTES:
 - Drawings are not contractually binding.
 - Before designing an installation, consult the certified dimensional drawings, available on request.
 - If the installation includes several units or if this (these) is (are) close to walls, please refer to chapters 3.13 - "Multiple chiller installation" and 3.14 - "Distance to the wall" of the installation manual to determine the space required.

Dimensions/clearances

30XA 502 - MCHE heat exchanger (standard)
 30XA 502 - Cu/Al heat exchanger (option 254/255)

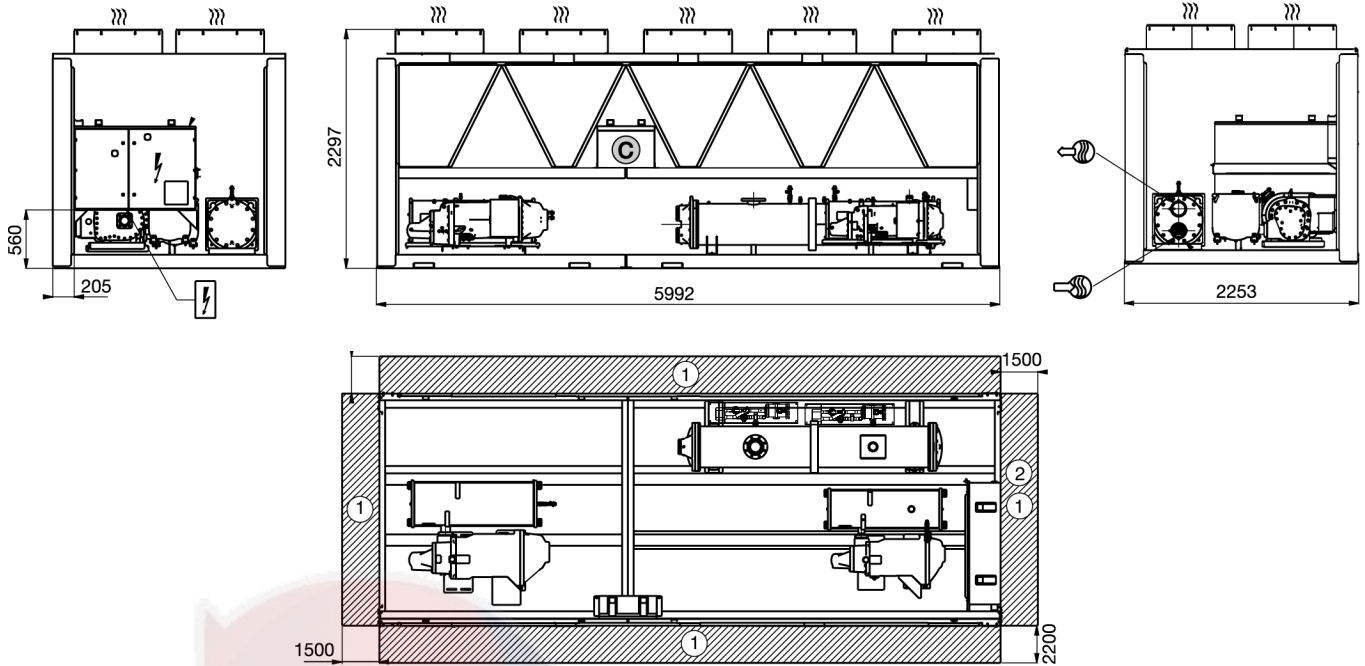

30XA 602-802-854-904 - MCHE heat exchanger (standard)
 30XA 602-702 - Cu/Al heat exchanger (option 254/255)

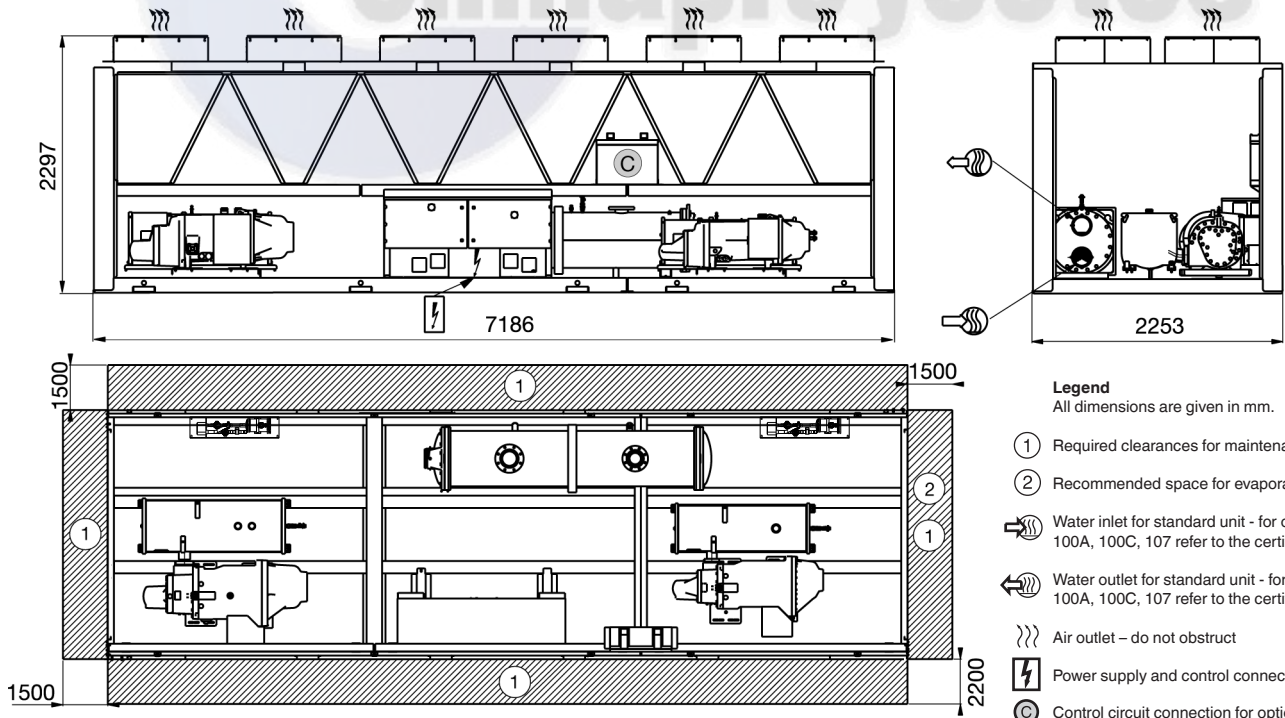

- Legend**
 All dimensions are given in mm.
- ① Required clearances for maintenance (see note)
 - ② Recommended space for evaporator tube removal
 - Water inlet for standard unit - for options 5, 6, 100A, 100C, 107 refer to the certified drawing.
 - Water outlet for standard unit - for options 5, 6, 100A, 100C, 107 refer to the certified drawing.
 - ⋯ Air outlet – do not obstruct
 - Power supply and control connection
 - Ⓒ Control circuit connection for option 158

NOTES:

- Drawings are not contractually binding.
- Before designing an installation, consult the certified dimensional drawings, available on request.
- If the installation includes several units or if this (these) is (are) close to walls, please refer to chapters 3.13 - "Multiple chiller installation" and 3.14 - "Distance to the wall" of the installation manual to determine the space required.

Dimensions/clearances

30XA 852-902 - MCHE heat exchanger (standard)
 30XA 752-852 - Cu/Al heat exchanger (option 254/255)

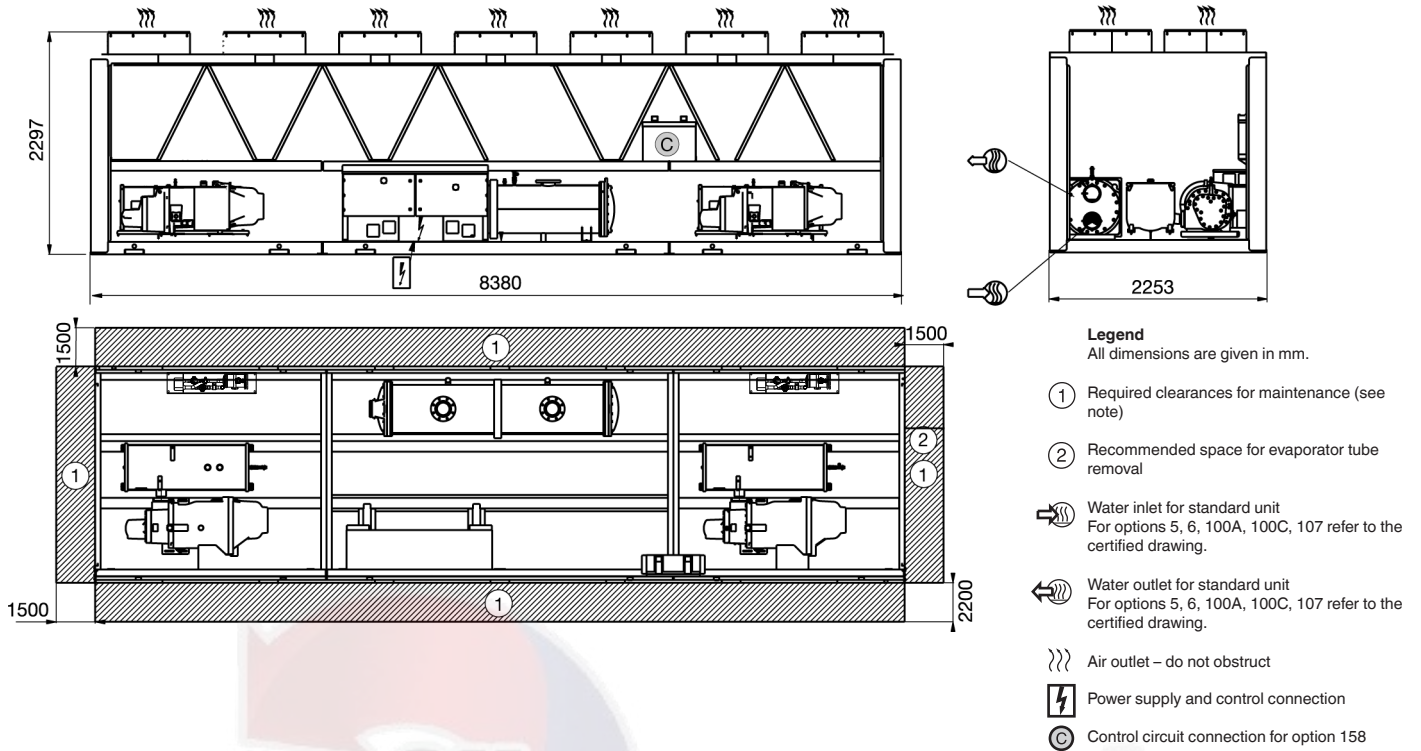

30XA 1002 - MCHE heat exchanger (standard)
 30XA 902-1002 - Cu/Al heat exchanger (option 254/255)

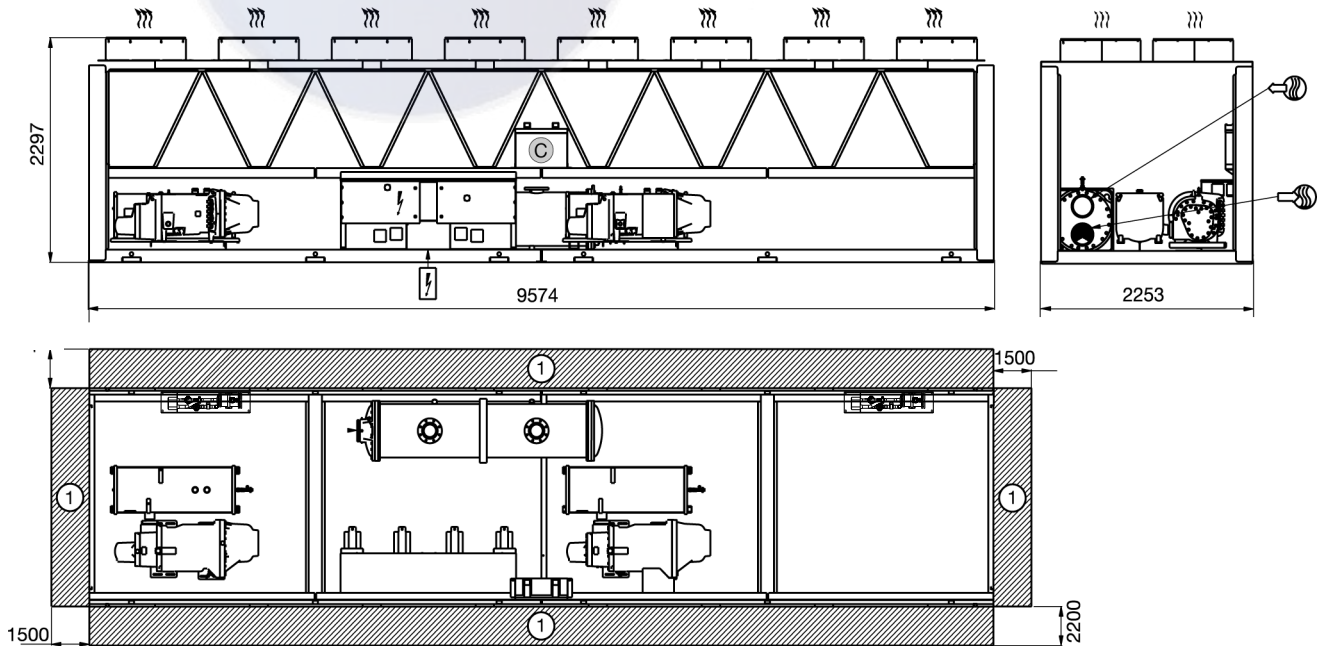

NOTES:

- Drawings are not contractually binding.
- Before designing an installation, consult the certified dimensional drawings, available on request.
- If the installation includes several units or if this (these) is (are) close to walls, please refer to chapters 3.13 - "Multiple chiller installation" and 3.14 - "Distance to the wall" of the installation manual to determine the space required.

Dimensions/clearances

30XA 1112, 1212, 1312, 1382 - MCHE heat exchanger (standard)

30XA 1112, 1212, 1312, 1382 - Cu/Al heat exchanger (option 254/255)

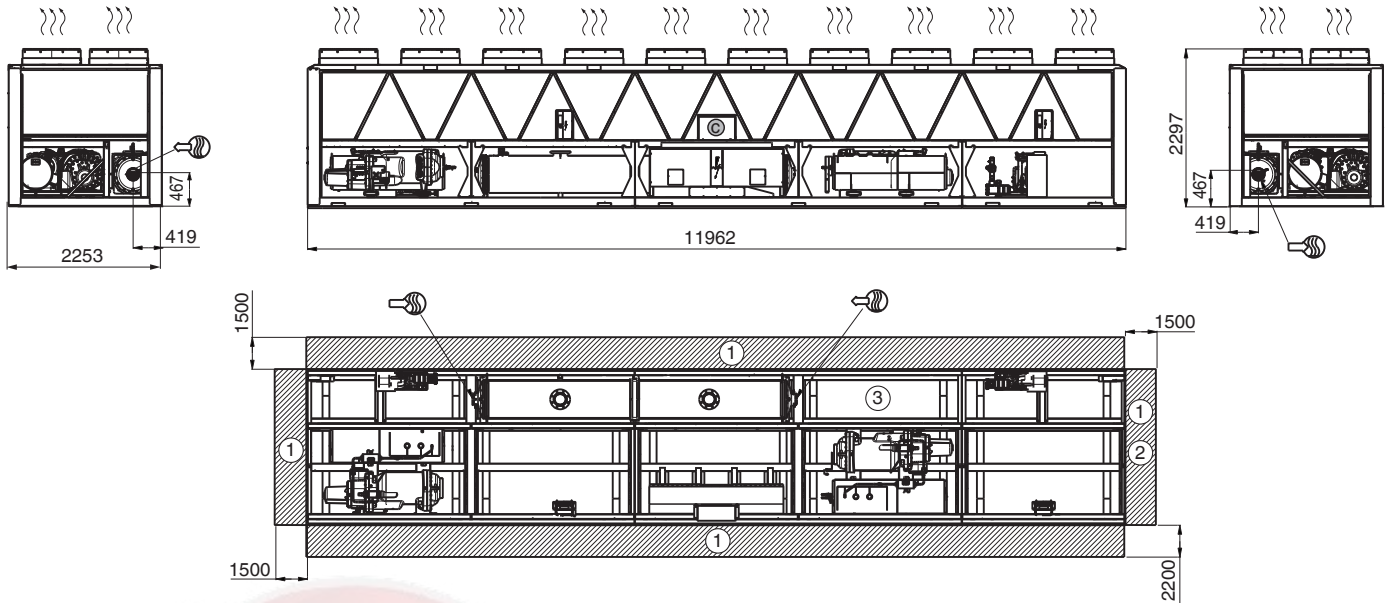

Legend

All dimensions are given in mm.

- ① Required clearances for maintenance (see note)
- ② Recommended space for evaporator tube removal
- ③ Required clearances for maintenance if options 100A + 107 are used together
- 11 Water inlet for standard unit - for options 5, 6, 100A, 100C, 107 refer to the certified drawing
- 12 Water outlet for standard unit - for options 5, 6, 100A, 100C, 107 refer to the certified drawing
- ⋈ Air outlet – do not obstruct
- ⚡ Power supply and control connection
- © Control circuit connection for option 158

NOTES:

- Drawings are not contractually binding.
- Before designing an installation, consult the certified dimensional drawings, available on request.
- If the installation includes several units or if this (these) is (are) close to walls, please refer to chapters 3.13 - "Multiple chiller installation" and 3.14 - "Distance to the wall" of the installation manual to determine the space required.

Dimensions/clearances

30XA 1402-1502 module 1/2 - MCHE heat exchanger (standard)
30XA 1402-1502 module 1/2 - Cu/Al heat exchanger (option 254/255)

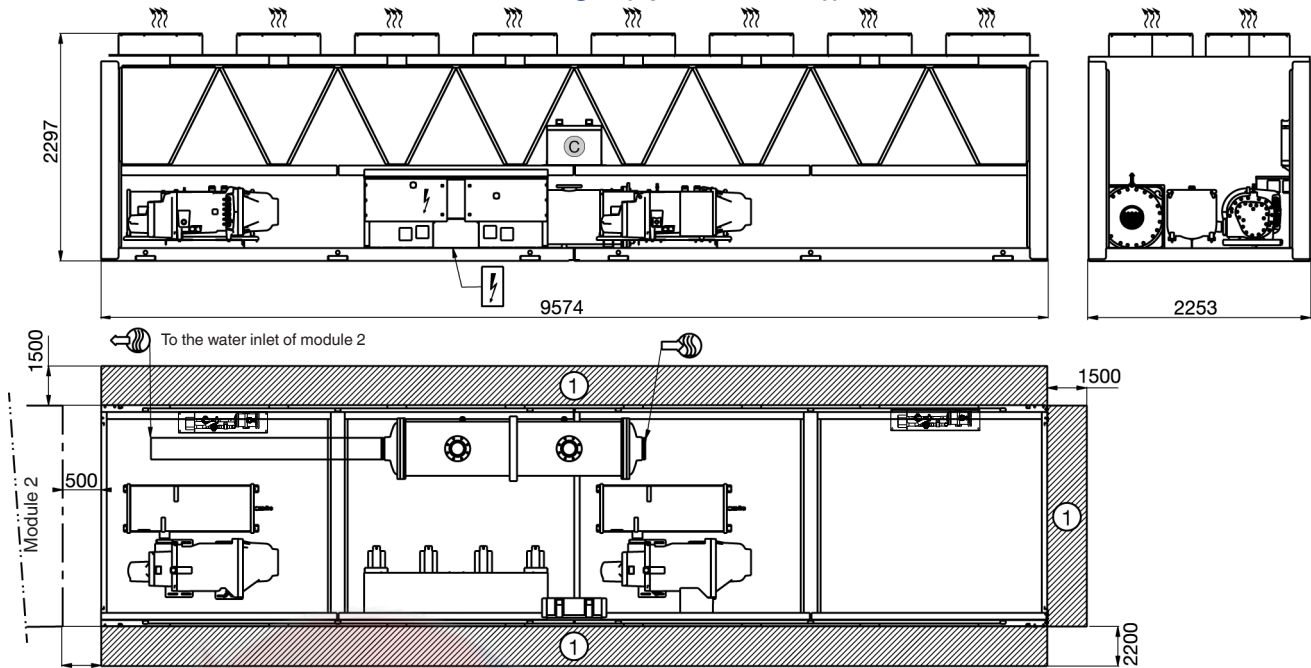

Legend

All dimensions are given in mm.

- ① Required clearances for maintenance (see note)
- ② Recommended space for evaporator tube removal
- Water inlet for standard unit
For options 5, 6, 100A, 100C, 107 refer to the certified drawing.
- Water outlet for standard unit
For options 5, 6, 100A, 100C, 107 refer to the certified drawing.
- Air outlet – do not obstruct
- Power supply and control connection
- Control circuit connection for option 158

30XA 1402-1502 module 2/2 - MCHE heat exchanger (standard)
30XA 1402-1502 module 2/2 - Cu/Al heat exchanger (option 254/255)

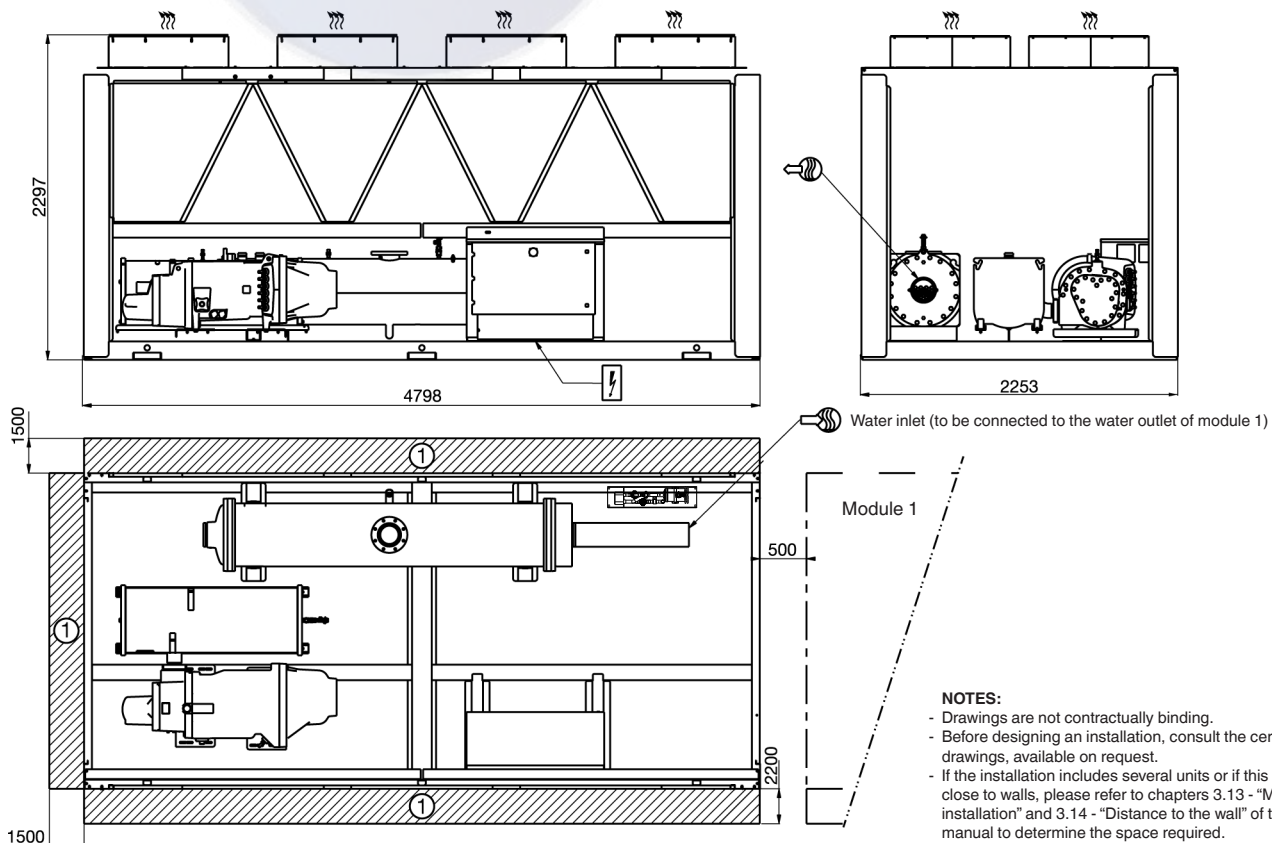

NOTES:

- Drawings are not contractually binding.
- Before designing an installation, consult the certified dimensional drawings, available on request.
- If the installation includes several units or if this (these) is (are) close to walls, please refer to chapters 3.13 - "Multiple chiller installation" and 3.14 - "Distance to the wall" of the installation manual to determine the space required.

Dimensions/clearances

30XA 1702 module 1/2 - MCHE heat exchanger (standard)
30XA 1702 module 1/2 - Cu/Al heat exchanger (option 254/255)

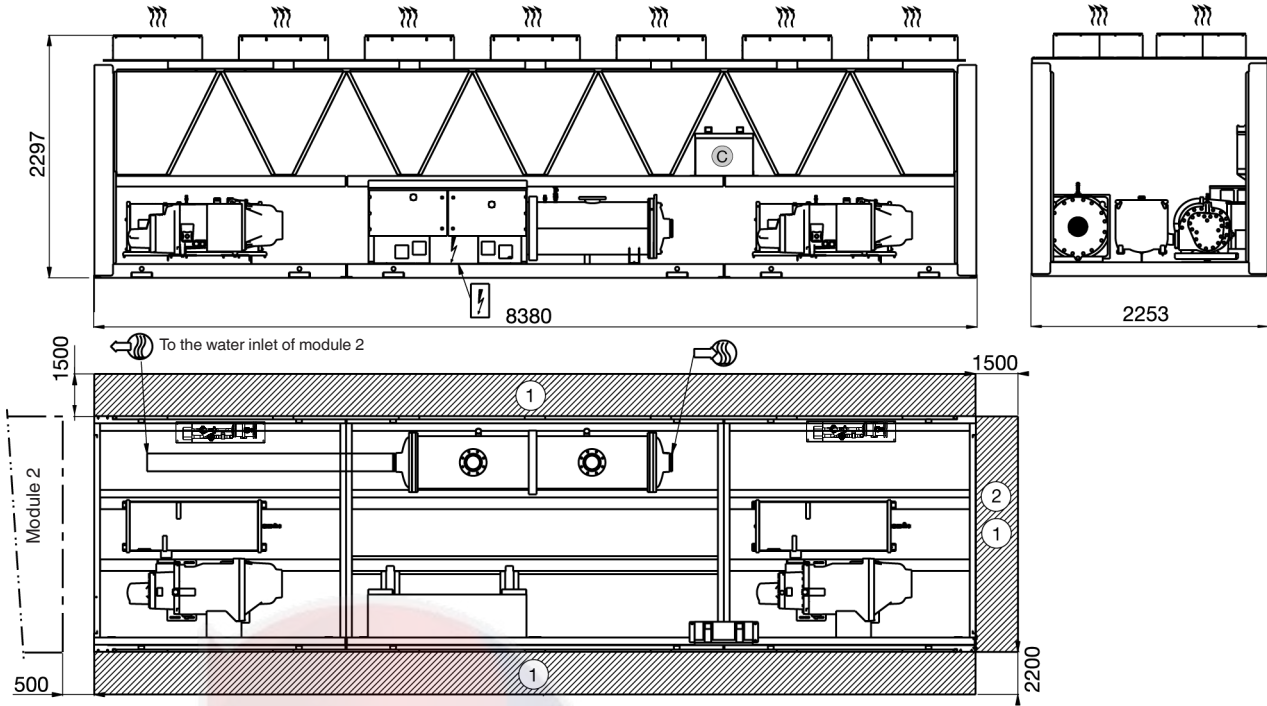

Legend

All dimensions are given in mm.

- ① Required clearances for maintenance (see note)
- ② Recommended space for evaporator tube removal
- ⊕ Water inlet for standard unit
For options 5, 6, 100A, 100C, 107 refer to the certified drawing.

- ⊖ Water outlet for standard unit
For options 5, 6, 100A, 100C, 107 refer to the certified drawing.
- ⋯ Air outlet – do not obstruct
- ⚡ Power supply and control connection
- ⓐ Control circuit connection for option 158

30XA 1702 module 2/2 - MCHE heat exchanger (standard)
30XA 1702 module 2/2 - Cu/Al heat exchanger (option 254/255)

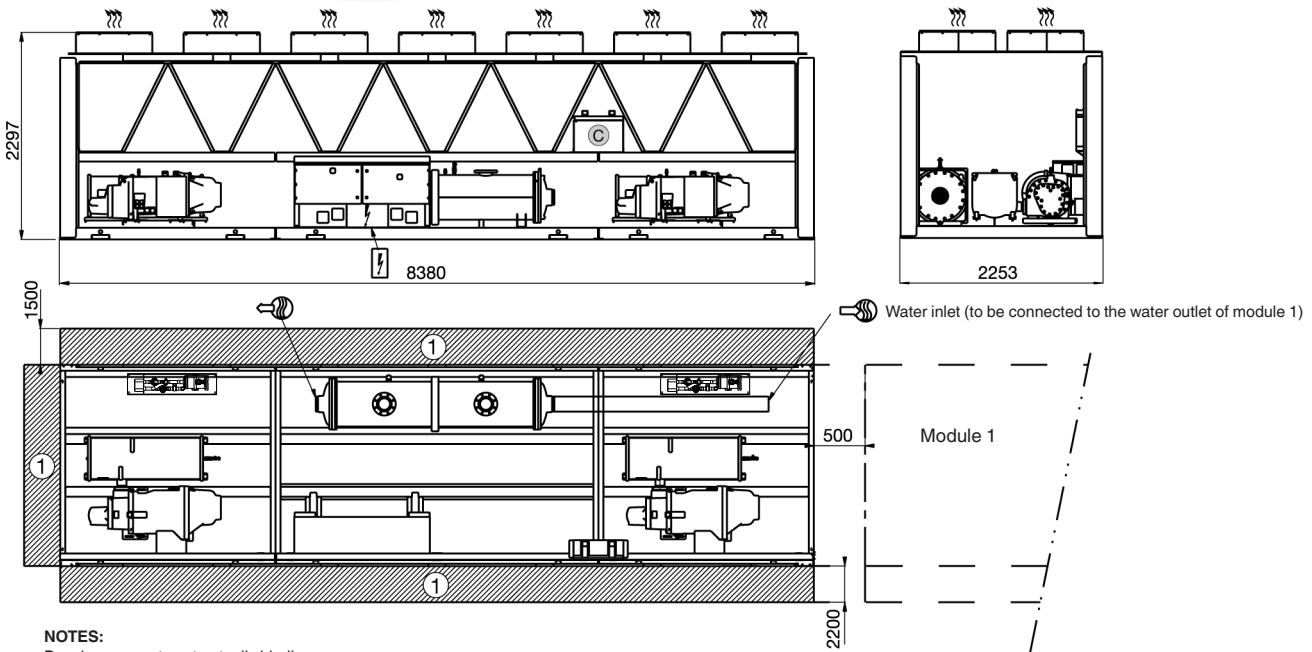

NOTES:

- Drawings are not contractually binding.
- Before designing an installation, consult the certified dimensional drawings, available on request.
- If the installation includes several units or if this (these) is (are) close to walls, please refer to chapters 3.13 - "Multiple chiller installation" and 3.14 - "Distance to the wall" of the installation manual to determine the space required.

Specification Guide

General description

Factory assembled single piece air-cooled chiller, shall include all factory wiring, piping, controls, refrigerant charge (R134a), completely independent refrigerant circuits, screw compressors, electronic expansion valves and equipment required prior to field start-up.

Quality assurance

Unit construction shall comply with European directives:

- Pressurised equipment directive (PED) 97/23/EC
- Machinery directive 2006/42/EC, modified
- Low voltage directive 2006/95/EC, modified
- Electromagnetic compatibility directive 2004/108/EC, modified, and the applicable recommendations of European standards
- Machine safety: electrical equipment in machines, general requirements, EN 60204-1
- Electromagnetic compatibility emission EN61000-6-4
- Electromagnetic compatibility immunity EN61000-6-2
- Directive 2009/125/EC with regard to ecodesign requirements for fans driven by motors with an electric input power between 125 W and 500 kW
- Directive 2005/32/EC with regard to ecodesign requirements for electric motors
- (if pumps on board) Directive 2009/125/EC with regard to ecodesign requirements for water pumps

Unit shall be designed, manufactured and tested in a facility with a quality management system certified ISO 9001 and environmental management system ISO 14001. Unit shall be run tested at the factory.

Design performance data

- Cooling capacity (kW):
- Unit power input (kW):
- Part load energy efficiency, ESEER (kW/kW):
- Full load energy efficiency, EER (kW/kW):
- Eurovent Class
- Evaporator entering/leaving water temperature (°C): ... /
- Fluid type:
- Fluid flow rate (l/s):
- Evaporator pressure drops (kPa):
- Outdoor air temperature (°C):
- Sound power level at full load (dB(A)):
- Dimensions, length x depth x height (mm): ... x ... x

Performance shall be declared in accordance with EN14511-3:2013 and certified by Eurovent.

The unit shall operate at full load with ambient temperatures ranging from -10 °C to 46 °C without use of additional adiabatic cooler systems, with evaporator leaving liquid temperature between 3.3 and +7 °C. When evaporator leaving water temperature is higher than 7 °C, up to 15 °C, the maximum outdoor air temperature may be lower to secure machine safe operation. The machine shall continue to operate (at reduced capacity) in ambient temperatures of up to 55 °C, with evaporator leaving liquid temperature between 3.3 and +10 °C.

- (Carrier option 119) The unit shall operate at full load up to 50 °C without use of additional adiabatic cooler systems, with evaporator leaving liquid temperature between 3.3 and +7 °C. The machine shall continue to operate (at reduced capacity) in ambient temperatures of up to 55 °C, with evaporator leaving liquid temperature between 3.3 and +15 °C.
- (Carrier option 5) The unit shall permit chilled brine solution production down to -6 °C when ethylene glycol is used, or down to -3 °C when propylene glycol is used.

- (Carrier option 6) The unit shall permit chilled brine solution production down to -12 °C when ethylene glycol is used, or down to -8 °C when propylene glycol is used.
- (Carrier option 28) The unit shall operate at full load down to -20 °C.

Frame

- Machine frame and enclosure shall be made of galvanised sheet steel
- Frame and enclosure shall be painted in oven-baked polyester powder paint in light grey colour (RAL 7035)
- Removable panels and electrical panel doors shall be accessible by 1/4-turn screws
- (Carrier option 23) Machine shall be protected from foreign bodies through the use of metal grilles factory-mounted on the four vertical faces. Coils refrigerant connections shall be covered by side panels of galvanised sheet steel, for enhanced aesthetic and safety during transportation.
- (Carrier option 23A) Coils refrigerant connections shall be covered by side panels of galvanised sheet steel, for enhanced aesthetic and safety during transportation.

Compressor

- Unit shall have semi-hermetic twin-screw compressors with internal relief valve and check valve to avoid reverse rotation on shut down
 - Unit shall be equipped with a muffler to reduce discharge gas pulsations
 - Compressor bearings shall be designed for minimum 73000 hours at maximum operating conditions
 - Capacity control shall be provided by a slide valve
 - Compressor capacity control shall be stepless from 100% to 30% load
 - Compressor shall start in unloaded condition
 - Motor shall be cooled by suction gas and protected through a dedicated electronic board against:
 - Thermal overload by internal winding temperature sensors
 - Electrical overload and short circuit by dedicated fuses (one per phase)
 - Reverse rotation
 - Loss of phase
 - Undervoltage and power supply failure.
- Lubrication oil system shall include pre-filter and external filter capable of filtration to 5 microns
- The oil filter line shall be equipped with service shut off valves for easy filter replacement
 - The oil separator, separated from the compressor, shall not require oil pump and shall include an internal muffler to reduce discharge gas pulsations
 - The oil separator shall be designed for 2100 kPa working pressure
 - The oil separator shall include a temperature actuated heater and an oil level safety switch
 - Compressors shall be installed on flexible anti-vibration mounts and isolated from the main unit chassis
 - (Carrier option 93A) Each compressor shall be equipped with a discharge shut-off valve
 - (Carrier option 279) Each compressor and oil separator shall be installed within an insulated acoustic enclosure with removable panels to facilitate service access

Evaporator

- Unit shall be equipped with a single flooded evaporator
- Evaporator shall be manufactured by the chiller manufacturer
- Evaporator shall be tested and stamped in accordance with the European directive for pressurised equipment 97/23/EC

- The maximum refrigerant-side operating pressure will be 2100 kPa, and the maximum waterside pressure will be 1000 kPa (2100kPa as an option)
- The evaporator shall be mechanically cleanable, shell-and-tube type with removable heads
- Tubes shall be internally and externally grooved, seamless-copper, and shall be rolled into tube sheets
- Shell shall be insulated with 19 mm closed-cell foam with a maximum K factor of 0.28. Evaporator thermal insulation shall be factory fitted
- The evaporator shall have a drain and vent in each head
- Chiller shall have only one water inlet & outlet connection with Victaulic couplings to avoid vibrations transmission and to accommodate minor pipework misalignment (Victaulic adapter kit shall be available on demand)
- Design shall incorporate either 1 or 2 independent refrigerant circuits
- Evaporator shall be fitted with electronic auto setting water flow switch. Paddle switches or differential pressure switches shall not be acceptable
- (Carrier option 281) Unit shall be fitted with a cooler jacket to protect the insulation from the long-term effects of UV radiation.
- (Carrier option 263) Coils shall be suitable for installations in the most severe environments. The protection shall consist on a flexible epoxy polymer coating uniformly applied to all coil external surface areas without material bridging between fins and louvers. The coating process shall be an electrocoating process with immersion in a coating bath and a final UV protective topcoat to shield the fins from ultraviolet degradation and to ensure coating durability and long life. Spray coating and non-electrocoating shall not be accepted. Coating process shall ensure complete coil encapsulation, including all exposed fin edges. The coating shall have a uniform thickness of 20 to 40 µm on all external coil surface areas including fin edges. The coating shall have minimal variation (<1%) in heat transfer on air flow per ARI 410. The coating shall have superior hardness characteristics of 2H per ASTM D3363 and cross hatch adhesion of 4B-5B per ASTM D3359. Impact resistance shall be up to 100 in/lb (ASTM D2794). Corrosion durability of coated microchannel coils shall be confirmed through testing to no less than 6000 hours constant neutral salt spray per ASTM B117.

Condenser

- Condenser coils shall be designed to ensure sub-cooling of the liquid refrigerant
- Condenser coils shall be V-shaped with a minimum open angle of 50° to ensure optimum air distribution
- Coils shall be entirely made of aluminium alloy, micro-channels type.
- Coils shall consist of a two-pass arrangement
- Coils shall be leak-tested at 15.5 bar with 100% He
- (Carrier options 254/255) Coils shall use copper tubes and aluminium fins
- Fans shall be direct-drive, equipped with an impeller with 9 aerodynamic blades and a rotating shroud to ensure optimal leak-tightness between the blades and the fan housing
- Fans impellers shall be of one-piece and made of a corrosion-resistant composite material, and statically and dynamically balanced
- The fans discharges shall be protected by polyethylene-coated steel wire grilles
- The three-phase electric motors shall have isolation class F, IP 55 protection and a minimum efficiency of 80%. They shall have individual overload protection via a disconnect switch
- (Carrier option 10) Fans shall be equipped with discharge connection flanges increasing available discharge pressure up to 60 kPa
- (Carrier option 262) Coils shall be suitable for installations in moderately corrosive environment. The protection shall consist on a nano-scale conversion coating, 100 to 200 nm thick, which uniformly covers the entire surface of the coil. Non conversion coating shall not be accepted. The coating process shall include immersion in a coating bath. The coating shall be applied by an autocatalytic conversion process which shall modify the surface of the aluminum producing a coating that is integral to the coil. Complete immersion shall ensure that 100% of the surface is coated, forming a continuous and even film. Spray coating process shall not be accepted. The coating shall be integral to the MCHE and shall not flake or loose adhesion with cross hatch adhesion of 5B per ASTM D3359. The thin coating shall have no variation in heat transfer on air flow per ARI 410. The coating shall utilise corrosion inhibitors which actively arrest damage due to environmental or mechanical damage. Corrosion durability of coated microchannel coils shall be confirmed through testing to no less than 4000 hours constant neutral salt spray per ASTM B117.

Refrigerant circuit

- Refrigerant circuit components shall include: compressor, oil separator, high and low side pressure relief devices, economiser, filter driers, moisture indicating sight glasses, long stroke electronic expansion device, and complete operating charge of both refrigerant R134a and compressor oil
- (Carrier option 92) For each refrigerant circuit, a compressor suction and discharge line shut off valve, an evaporator inlet valve and economiser line valve, shall be mounted to isolate all main components (filter drier, oil filter, expansion device and compressor) and allow refrigerant to be safely stored during service operation
- (Carrier option 93A) Each compressor shall be equipped with a discharge shut-off valve
- (Carrier option 257) Compressor and oil separator sub-assembly and refrigerant gas suction line shall be acoustically insulated
- (Carrier option 258) Compressor and oil separator sub-assembly, refrigerant gas suction line and the economiser subassembly (if needed) shall be acoustically insulated.

Power control boxes

- Unit shall operate at 400 Volts (+/- 10%), 3-phases, 50 Hertz power supply without neutral
- Unit shall be designed for simplified connection on TN(s) networks
- Unit shall have maximum holding short circuit current of 38000 Amps up to 500 kW, of 50000 Amps up to 1000 kW and 100000 Amps up to 1700 kW nominal cooling capacity
- Control circuit voltage shall be 24 V maximum, supplied by a factory-installed transformer
- Unit shall be supplied with factory-installed main circuit breaker/isolator
- Unit shall have a factory installed star/delta starter as standard to limit electrical inrush current
- Power control box is powered painted with hinged and gasket sealed doors and is protected to IP44CW
- (Carrier option 20A) The power control box shall be protected to IP54 to grant safe operation for installations in polluted environment
- (Carrier option 70D) The main electrical disconnect switch shall integrate fuses for protection against over current flow
- (Carrier option 81 for sizes 1102/1502, standard for all other sizes) Unit shall have single point power connection
- (Carrier option QM231) The unit shall integrate additional capacitors to ensure a power factor of 0.95 at full load.

Controls

- Unit control shall include as a minimum: microprocessor with non-volatile memory, picture guided unit/operator interface, the LOCAL/OFF/REMOTE/CCN selector and a 5 inches coloured touch-screen display with multiple language capability
- (Carrier option 158A) Unit control shall include as a minimum: microprocessor with non-volatile memory, picture guided unit/operator interface, the LOCAL/OFF/REMOTE/CCN selector and a 7 inches coloured touch-screen display with multiple language capability
- Pressure sensors shall be installed to measure suction, discharge, and oil pressure
- Temperature probes shall be installed to read cooler entering and leaving temperatures and outdoor air temperature
- Unit control shall have an IP port to permit user connection via web browser, allowing same level of access to control menus as unit mounted interface (excluding start/stop and alarm reset capabilities)
- Control shall store technical documentation, drawings and spare parts list specific to each particular unit
- (Carrier option 148B) A two-directional communication board shall allow plug and play interfacing of the machine with any BMS using the J-Bus protocol
- (Carrier option 148D) A two-directional communication board shall allow plug and play interfacing of the machine with any BMS using the LonTalk protocol
- (Carrier option 149) Machine shall be supplied with factory-installed two-directional high-speed communication using BACnet protocol over Ethernet network (IP-connection). The BACnet over-IP communication shall have no limitation in reading/writing controller points and shall use standardised alarm codes as defined with BACnet protocol. Field programming shall be required
- (Carrier option 298) Machine shall be accessible via wireless connection for remote monitoring with the scope of preventive maintenance.

Unit shall be capable of performing the following functions:

- Electronic expansion valve control optimising evaporator refrigerant charge while ensuring minimum refrigerant superheat and optimum subcooling at condenser outlet
- Capacity control based on leaving chilled fluid temperature
- Limitation of the chilled fluid-temperature pull-down rate at start-up to an adjustable range of 0.1 °C to 1.1 °C per minute to prevent excessive demand spikes at start-up
- Automatic change-over and cycling of compressors to equalise running hours and number of starts
- Reset enable of leaving chilled-water temperature based on the outdoor air temperature or via 0-10 V signal (as option)
- Dual set point management for the leaving chilled water temperature activated by a remote contact closure signal or by the built in time clock
- 2-level demand limit control (between 0 and 100%) activated by remote contact closure or by the built in time clock
- Time scheduling management to enable unit start-up control, demand limit and set-point changes
- Trending of main variables (accessible by web browser only)
- (Carrier option 58) lead/lag type control of two chillers running in series or parallel
- (Carrier option 116) Evaporator pump control, including additional safety pump (if installed)

- (Carrier option 156) The following inputs contacts shall be available on the unit control board:
- Setpoint reset by indoor air temperature sensor
- Cooling setpoint reset by 4-20 mA
- Time schedule override
- Ice storage input
- Demand limit
- Unit shut down

The following outputs contacts shall be available on the unit control board:

- Instantaneous chiller capacity by 0-10 V signal
- Complete shut-down due to a chiller fault
- Compressor operation indication.

Diagnosis

- Control interface shall be capable of displaying set points, system status including temperatures, pressures, current for each compressor, run time and percent loading
- Control interface shall perform trending of up to 10 preselected variables
- Control system shall allow a quick test of all machine elements to verify the correct operation of every switch, circuit breaker, contactor etc. before the chiller is started
- In case of alarm, control system shall send an email to specific mail box set by user during machine commissioning
- Control shall have black box function which permit to store data set of 20 variables with interval of 5 seconds, during 14 minutes preceding the alarm and 1 minute following the alarm event. The black box recording capability shall permit recording for 20 events and once the threshold is reached new data shall over-write the oldest ones.

Safeties

Control system shall provide the unit with protection against the following:

- Reverse rotation
 - Low chilled water temperature
 - Low oil pressure (per compressor)
 - Current imbalance
 - Compressor thermal overload
 - High pressure (with automatic compressor unloading in case of excessive condensing temperature)
 - Electrical overload and short circuit
 - Loss of phase, undervoltage and power supply failure
- Control shall provide separate general alert (minor incident) and alarm (circuit down) remote indication.

Hydraulic module (optional)

- (Carrier option 116B/C/F/G) A choice of different pump types and configuration shall be available:
- Single high-pressure pump
- Dual high-pressure pumps
- Single low-pressure pump
- Dual low-pressure pumps

In case dual pumps configuration, the unit control shall automatically manage the change-over and cycling of pumps to equalise running hours and number of starts

- The hydronic module shall be integrated in the chiller chassis without increasing its dimensions
- The hydronic module shall include the following elements:
- Removable screen filter
- Centrifugal monocoil water pump with three-phase motor equipped with internal over-temperature protection
- Electronic water flow switch without paddle

- Relief valve calibrated to 4 bar
- Long stroke flow control valve
- Pressure gauge and valve set for differential pressure measurement
- The water pump shall be isolated from the chiller structure and water piping by anti-vibration mountings and expansion compensators, in order to limit vibration and noise transmission
- The water piping shall be protected against corrosion and equipped with drain and purge plugs
- The hydraulic connections shall be Victaulic type
- Both pump and piping shall be fully insulated with polyurethane foam covered with aluminum panels to prevent condensation

- Pumps frost protection shall be guaranteed down to -20 °C by electric resistance heaters
- Piping frost protection shall be guaranteed down to -20 °C by automatic pumps activation when liquid temperature falls below a safety limit

Total heat recovery (optional)

- (Carrier option 50) The unit shall include an additional heat exchanger in parallel with the condenser coils to recover 100% of condensing heat





Order No.: 13450-20, 07.2015. Supersedes order No.: 13450-20, 01.2015.
Manufacturer reserves the right to change any product specifications without notice.



Quality and Environment
Management Systems
Approval

Manufactured by: Carrier SCS, Montluel, France.
Printed in the European Union.