

Ceiling Concealed Chilled Water Fan Coil Unit Energy Saving Type

FWW200	FWW800
FWW300	FWW1000
FWW400	FWW1200
FWW500	FWW1400
FWW600	

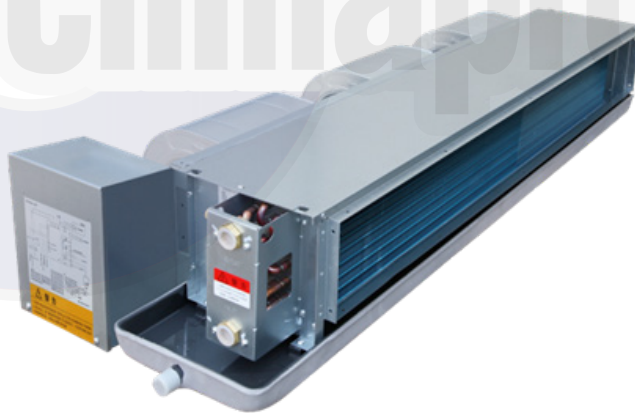

DAIKIN INDUSTRIES, LTD.

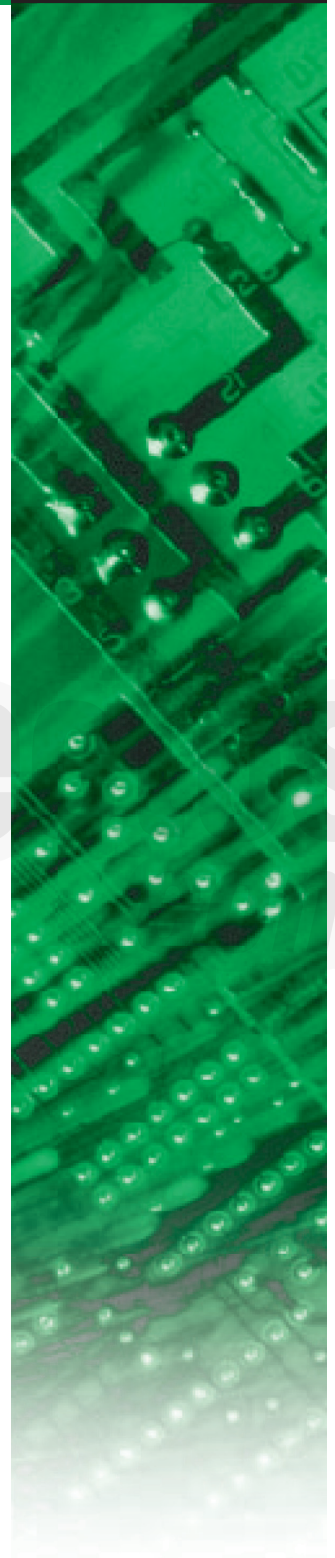



Globally leading DAIKIN fan coil technology

DAIKIN China

Climaproyectos
.com

Contents

- | | | | |
|----|-----------------------------------|----|------------------------------------|
| 04 | Unit Characteristics | 08 | Specifications |
| 13 | Electric Wiring Diagram | 14 | Air Flow and Static Pressure Curve |
| 15 | Temperature Controller and Valves | | |

Scope of application

For years, DAIKIN has been providing the society with multiple types of high-quality air handling systems and has made remarkable achievements in related fields. Integrating the advanced air conditioner manufacturing technology and process of DAIKIN, DAIKIN fan coil units showcase more compact structure, more convenient installation and maintenance, more efficient performance and lower noises, and have been widely used in public buildings, hospitals, office buildings, hotels, high-end residences, etc.



Project: SBF CENTER in Singapore



Project: SBF CENTER in Singapore



Research and Development Center of China Life, Beijing

DAIKIN's DC brushless fan coil units have been chosen by wide users, including Convention Center of Nanjing Youth Olympic Games, Hainan Cancer Hospital, Haikou, Research and Development Center of China Life, Beijing, Instrument Industrial Park of Yizhuang Children's Hospital, Guiyang Xinghewan Hotel, and Tianjin Luhua Zhuangyuan.

Most complete product series

DAIKIN has been widely known for its complete product series in the field, covering the entire categories of air conditioners, purification equipment and refrigerating equipment. It boasts the most complete fan coil series in the field, and achieves experience of a full set of products including units, valves and control products, making things more convenient for users.



Four-side air outlet embedded series



Horizontal concealed series



Vertical concealed series



Horizontal surface mounted series



Vertical surface mounted series

Building nature based on science and technology

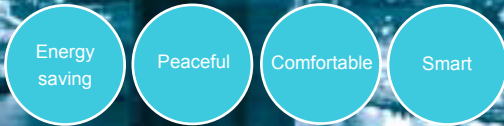

For over one hundred years, DAIKIN has been dedicated to research in air conditioning technologies. Recently, with a view to fitting into the ever increasing demands for energy saving in the world, and responding actively to the national policies on cutting energy use and pollution, DAIKIN strives hard to create its 3rd-generation DC brushless fan coil to make it a new classic product based on its almost up to one hundred years experiences in fan coil structure and performance. The units are widely used in places with higher requirements for energy saving and comfort, such as commercial and office buildings, high-end residences, hospitals and governmental projects.

Energy Saving

- The highly efficient DC brushless motor adopts the advanced proportional digital core algorithm and PFC unit to achieve the maximum power factor of 99%. Compared to the traditional fan coil, the unit saves energy by over 50% and achieves more remarkable energy saving effect at medium or low speed.
- The unit employs the FOC space vector control system to adjust the corresponding motor speed in time, reduce unnecessary waste in electric energy and enhance energy utilization efficiency significantly.
- The heat exchangers of the full series of units adopt anti-salt and anti-corrosive louvered hydrophilic aluminum foil to improve the heat exchange efficiency.
- One-key access to the energy saving mode ensures that the unit operates at a low fan speed and satisfy the double requirements for a comfortable indoor environment and energy saving.

*Power factor: It refers to the ratio between the actually consumed power and the power supply capacity. Therefore, the higher the power factor, the more unnecessary losses that can be avoided during power transmission. In this way, the power utilization efficiency is enhanced.

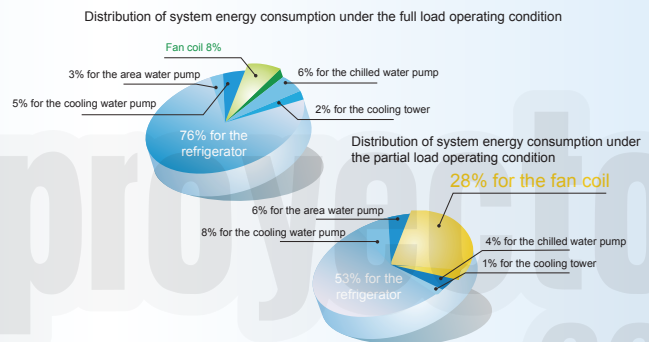

In the actual application, energy consumption of the fan coil accounts for 28% of the total energy consumption of air conditioning system.

The air conditioner operates at partial load at 90% of time. The traditional fan coil takes up about 28% of total energy consumption because it cannot regulate its power consumption as needed.

Note: The foregoing statistical data may differ from the actual engineering data due to regional and climatic changes.

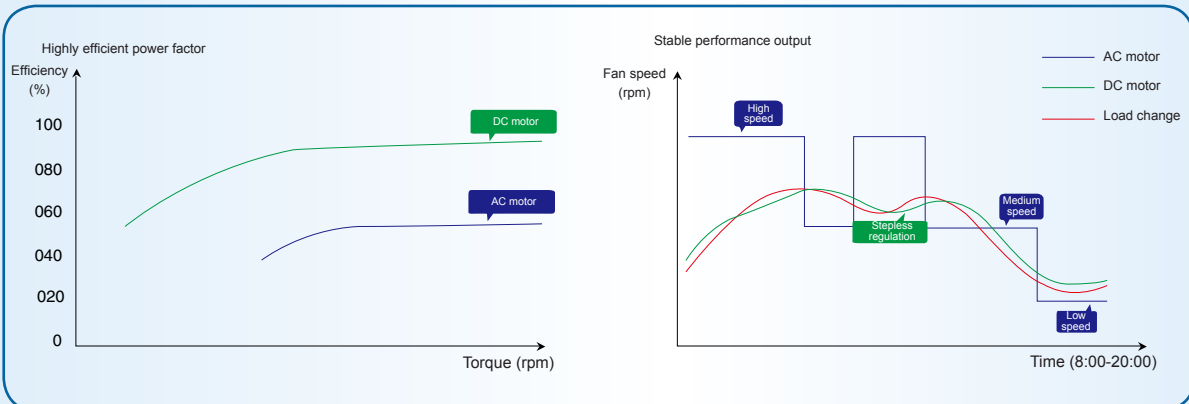



Quiet

- The DC brushless motor adopts electronic commutation to avoid electromagnetic interference and noises, ensuring a quiet and comfortable indoor environment during operation.
- The motor adopts stepless speed regulating technology, ensuring a stable noise band curve and remarkable sound quality. The medium/low speed has more advantages compared with traditional motors.
- The unit uses the wide impeller fan following the aerodynamic design and has passed the static and dynamic balance tests, with even air supply and lower noises.
- A rubber axle sleeve is used between the fan and the motor to realize flexible connection, reducing the vibration noise generated when the unit starts/stops and load is increased/decreased.



Comfort

- The proportional thermostatic control technology implements stable air output by logically controlling motor speed output based on a certain proportion, creating a comfortable space.
- Temperature sensor of the wired controller is combined with temperature sensor of return air to realize more timely and accurate temperature control.
- The standard control module for unit regulates air flow intelligently, allows for real-time changes according to indoor operating condition, and realizes precise stepless air flow regulation to enable the optimum comfort for people indoors.
- More optional functional parts are provided, including the condensate water pump, electric heating module, UV sterilization module and door card function. The wide application enables it to meet the needs of different users.



Smart

- The standard multi-function controller presents a stylish appearance to meet the needs for different decoration styles.
- Pulse width modulation (PWM) enables the motor to realize electronic commutation and achieves a temperature control precision up to $\pm 0.5^{\circ}\text{C}$, matching the operating air flow under the set temperature perfectly.
- Modbus communication protocol is supported to enable centralized area management and PC network control.
- The access point to room card function is configured so that the unit starts or stops automatically when the user enters or leaves the room.

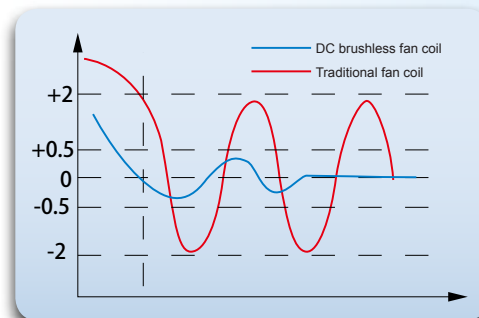

Product structure

Centrifugal impeller

The centrifugal double-suction fan featuring high-efficiency wide-impeller and forward-curved multi-blade is adopted to implement low speed, large air flow and low noise.



Highly efficient DC brushless motor

High efficiency and energy saving, powerful, stable and quiet operation; protection grade IP44 and configuration of the international brand NSK bearing, ensuring efficient, safe and maintenance-free operation.



Plastic coated metal hose

The motor cable protection pipes use light and flexible plastic coated metal hoses with excellent protection performance; the hose is characterized by corrosion resistance, wear and high temperature resistance, and good insulation, guaranteeing safety use to a larger extent.

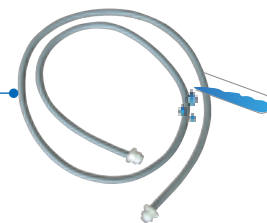

High-efficiency heat exchanger

Formed using high quality copper tubes and highly efficient hydrophilic aluminum fins through mechanical expansion joint to reduce heat resistance; Quasi counterflow fan coil design enables thorough heat exchange between air and water to guarantee high efficiency in heat exchange.



New self-slope drain pan

The self-slope structure design ensures quick drainage of condensate water; With spray on both sides for anti-corrosion, the tray surface is cleaner; the integrated design is adopted to avoid cold bridges.



Manual air vent discharge valve

The unit is configured with manual air vent discharge valve for convenient operation, quicker discharge, and easier installation. The discharge valve is placed at the highest point to guarantee thorough discharging of air in the system and ensure the heat exchange effect.

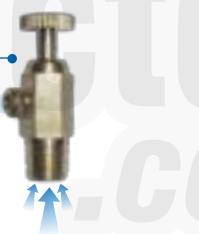

Certificated by authoritative institutions



Features (optional by networking type)

The stepless speed regulation DC brushless fan coil is divided into two series based on control functions: standard type and networking type. The standard type meets the regular single unit control demands; while the networking types has more diversified control functions to enable control over Modbus communication, water pump and electric heating and diversified use demands of customers..

PFC module

- Active power factor correction is targeted at variable load and the power factor of load device can be up to 99%;
- With compact size and high output power, the module also has simple structure and high reliability.

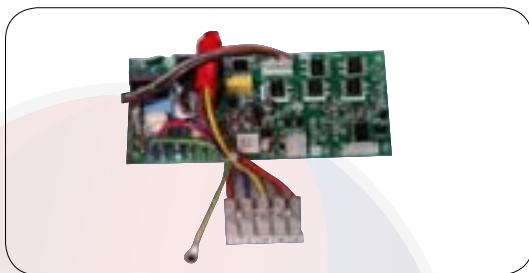

Built-in lifting pump

- The high-lift condensate water lifting pump is provided as an option to reduce the installation height to ceiling and make installation more convenient;
- The smart water level switch is configured to detect the water level of drain pan and ensure that the condensate water will be removed timely manner and a quiet environment is provided by saving energy intelligently.

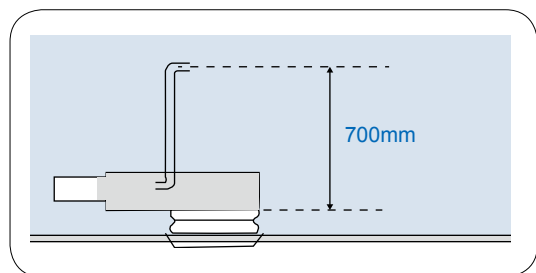

Electrical heating module

- PTC auxiliary electric heating can be selected for the unit. It generates heat at a constant temperature with efficient heat transfer and is rarely affected by power voltage, thus ensuring that the heating demand is met;
- Dual dual overheat protections to ensure safety in use.



Door card function

- The user can insert and remove the door card simply to enable the air conditioner to operate automatically with low energy consumption;
- Used in hotels and rental apartments. The linkage control between the key card and the air conditioning unit is implemented to facilitate management.



Modbus transmission

- The standard Modbus communication protocol is supported to realize joint control with the building automation system, ensuring centralized management of remote automation and monitoring;
- The communication mode and operation can be implemented easily, ensuring stable and reliable system operation.

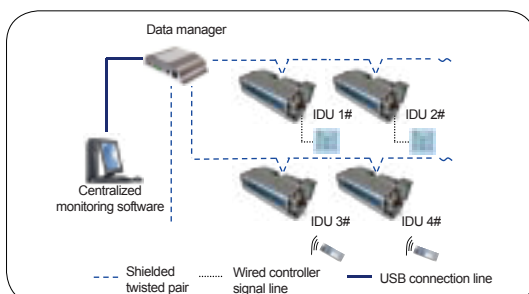

UV sterilization module

- The specially designed UV sterilization device, which is highly efficient and has a long service life, prevents the bacteria and viruses from replicating themselves and kills them quickly;
- The UV lamps provide control access points, and in this way users can exercise control through wiring by themselves or realize joint control with the fan.



Nomenclature

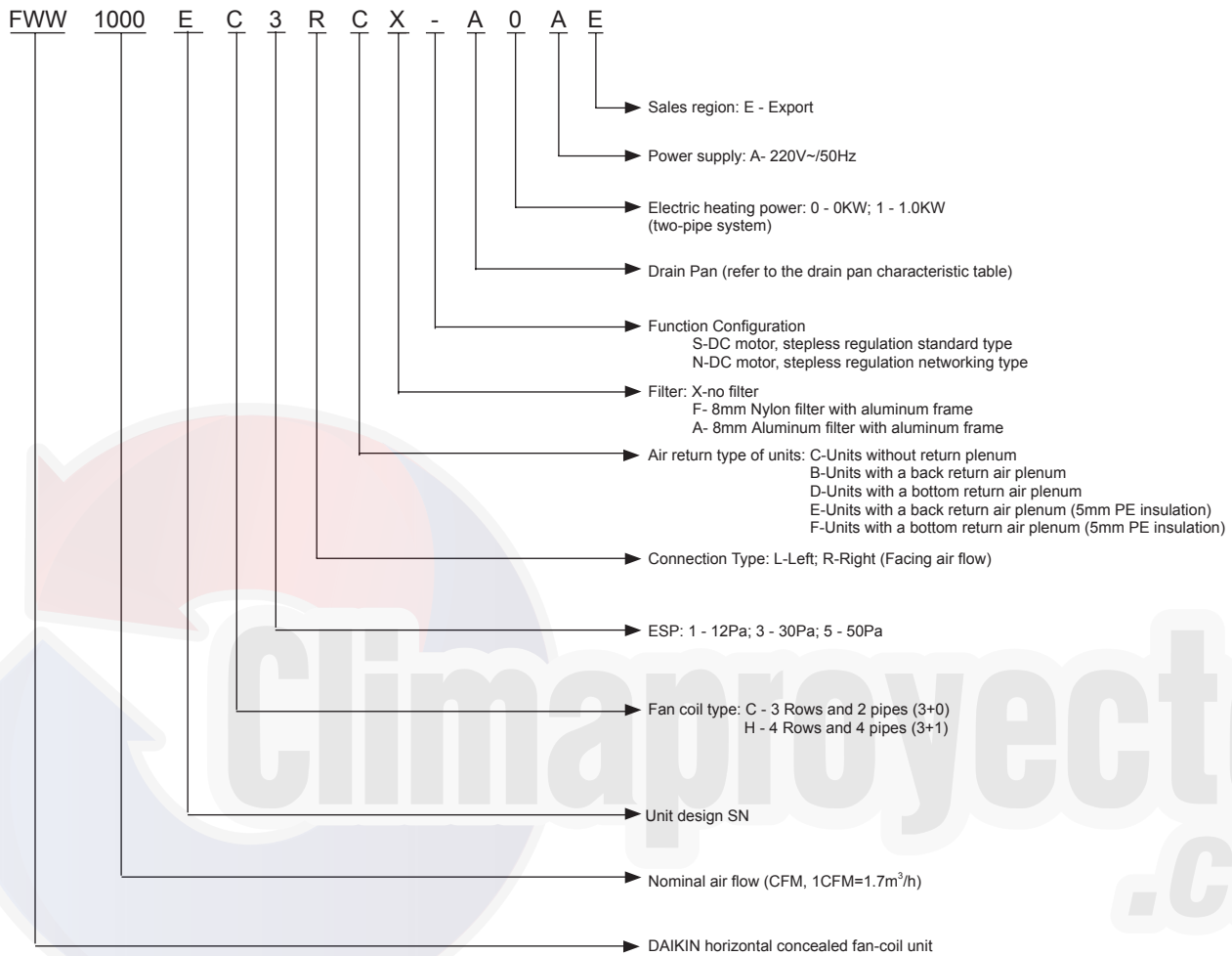

Drain Pan table

Code	Material	Insulation work	Length
A	Cold-rolled steel sheet	7mm PE	Standard length
B	Cold-rolled steel sheet	7mm PE	Extended 100mm
C	Cold-rolled steel sheet	7mm PE	Extended 200mm
D	Cold-rolled steel sheet	7mm PE	Extended 300mm
E	Stainless steel	7mm PE	Standard length
F	Stainless steel	7mm PE	Extended 100mm
G	Stainless steel	7mm PE	Extended 200mm
H	Stainless steel	7mm PE	Extended 300mm
I	Cold-rolled steel sheet	6mm Armstrong Grade 1	Standard length
J	Stainless steel	6mm Armstrong Grade 1	Standard length
K	Cold-rolled steel sheet	6mm Armstrong Grade 0	Standard length
L	Stainless steel	6mm Armstrong Grade 0	Standard length

Code	Material	Insulation work	Length
M	Cold-rolled steel sheet	6mm Armstrong Grade 1	Extended 100mm
N	Stainless steel	6mm Armstrong Grade 1	Extended 100mm
P	Cold-rolled steel sheet	6mm Armstrong Grade 0	Extended 100mm
Q	Stainless steel	6mm Armstrong Grade 0	Extended 100mm
R	Cold-rolled steel sheet	6mm Armstrong Grade 1	Extended 200mm
S	Stainless steel	6mm Armstrong Grade 1	Extended 200mm
T	Cold-rolled steel sheet	6mm Armstrong Grade 0	Extended 200mm
U	Stainless steel	6mm Armstrong Grade 0	Extended 200mm
V	Cold-rolled steel sheet	6mm Armstrong Grade 1	Extended 300mm
W	Stainless steel	6mm Armstrong Grade 1	Extended 300mm
X	Cold-rolled steel sheet	6mm Armstrong Grade 0	Extended 300mm
Y	Stainless steel	6mm Armstrong Grade 0	Extended 300mm

Note: Stainless steel drain pan uses 304 stainless steel.

Technical Specifications of FWW-EC Unit (Two-Pipe System with 3 Rows of Coils)

Performance		Model	FWW200EC	FWW300EC	Mcv/foeec	FWW500EC	FWW6D0EC	FWW800EC	FWW1000EC	FWW1200EC	FWW1400EC	
Nominal air flow (12Pa, 30Pa, 50Pa)	H		340	510	680	850	1020	1360	1700	2040	2380	
	M		255	383	510	638	765	1020	1275	1530	1785	
	L		170	255	340	425	510	680	850	1020	1190	
Cooling capacity (W)	Total cooling capacity	H	2320	3550	4200	5200	6100	8200	9500	11500	13500	
	Sensible cooling capacity	H	1445	2400	2938	3595	4370	5835	6930	8580	9790	
Heating capacity (W)		H	3700	5600	7200	8650	10200	13800	16000	19500	22000	
Rated power (W)	ESP: 12Pa	H	16	22	31	42	58	70	104	126	156	
		M	10	13	17	22	30	38	53	63	79	
		L	6	7	9	10	13	19	24	27	32	
	ESP: 30Pa	H	21	29	41	52	70	88	122	150	180	
		M	12	17	22	27	36	45	61	73	91	
		L	7	9	10	12	15	21	27	30	35	
	ESP: 50Pa	H	28	38	52	66	85	107	145	180	211	
		M	15	21	25	32	42	54	71	85	103	
		L	8	10	12	14	17	24	30	34	40	
	Operating current (A)	ESP: 12Pa	H	0.13	0.19	0.26	0.35	0.50	0.57	0.84	1.01	1.28
		ESP: 30Pa	H	0.17	0.25	0.33	0.44	0.58	0.70	0.98	1.17	1.47
		ESP: 50Pa	H	0.23	0.32	0.41	0.54	0.69	0.85	1.15	1.37	1.68
Noise (dB(A))	ESP: 12Pa	H	32.5	34.5	37.0	40.0	43.5	44.0	47.0	48.0	50.5	
		M	27.0	29.0	30.5	33.0	38.0	37.0	40.5	40.5	44.0	
		L	22.5	22.5	24.0	24.5	28.0	27.5	31.0	31.0	33.5	
	ESP: 30Pa	H	36.5	38.0	40.5	42.5	45.5	46.0	48.5	49.0	52.0	
		M	30.0	32.0	33.0	36.0	39.5	39.0	42.5	42.0	45.0	
		L	23.5	24.5	25.5	26.0	29.0	29.0	32.5	32.0	34.5	
	ESP: 50Pa	H	40.0	41.0	43.5	45.0	47.0	48.0	49.5	51.0	53.0	
		M	34.5	34.5	36.0	38.0	41.5	41.0	44.0	43.5	48.5	
		L	26.0	25.5	27.5	28.5	30.5	31.0	34.0	33.5	36.0	
	Water flow rate (m ³ /h)			0.41	0.60	0.72	0.88	1.06	1.43	1.65	1.94	2.30
	Water Pressure drop (kPa)	Cooling		12.0	28.0	15.0	23.0	34.0	36.0	29.0	41.0	42.0
		Heating		10.0	23.0	12.0	19.0	29.0	29.0	24.0	34.0	35.0
Coil	Type	Mechanical expansion joint of high-quality copper tubes with hydrophilic louver aluminum fins										
	Working pressure	1.6MPa										
Fan	Type	centrifugal (Forward)										
	Qty	1	2	2	2	2	3	4	4	4	4	
Motor	Type	Single-phase capacitor motor configured with the sealed ball bearing with high precision and low noises										
	Qty	1	1	1	1	1	2	2	2	2	2	
	Power supply	220V-/50Hz										
	Protection grade	IP44										
Water inlet/outlet pipe	Insulation grade	B										
	Size of pipe connector	External thread of Rc 3/4 taper pipe										
Condensation pipe	Size of pipe connector	External thread of R3/4 taper pipe										
Dimension (mm)	Width (C/B/D)	675	815	915	995	1095	1425	1525	1725	1985		
	Depth (C/B/D)	465/516/497										
	Height (C/B/D)	235										
Net weight (kg)	Without the return air plenum	13.2	16.2	18.1	18.6	20.3	29.4	31.3	37.4	43.1		
	With the return air plenum	15.9	19.5	21.8	22.6	24.6	35.1	37.4	44.3	51.3		

Note:

- The cooling capacity is measured when the air inlet dry bulb/wet bulb temperature is 27°C/19.5°C and the water inlet/outlet temperature is 7°C/12°C.
- The heating capacity is measured when the air inlet dry bulb temperature is 21°C, the water inlet temperature is 60°C and the water flow is the same as that of the cooling condition.
- The rated air flow is measured in the standard air and dry coil condition (dry bulb temperature: 20°C).
- The sound pressure level (SPL) noise value is obtained in a semi-anechoic room with the background level: 11.5 dB(A) based on the unit without the return air plenum and filter (compliance with GB/T19232-2003).
- H, M, and L indicate high, medium, and low fan speeds respectively; the static pressure refers to the static pressure at the unit outlet.
- Performance parameters in the preceding table are all obtained under the 220 V/50 Hz power supply.
- The left/right pipe connection direction can be changed on the jobsite for the unit. After connection direction change, multiply the cooling/heating capacity by the correction factor 0.85~0.9.
- The air flow, rated cooling and heating capacity in the preceding table are obtained based on the unit without the return air plenum and filter. For a unit with the back/bottom return air plenum, multiply the preceding values by the correction factor 0.92~0.95.
- Conditions for the noise test: 1m*1m under the lateral bottom of air outlet; in actual installation, the obtained noise value may be different from that in the preceding table due to background noise or other reasons. The noise value of the unit with air return at the bottom is higher than that with air return at the back.

FWW-E DC Brushless Fan Coil

Technical Specifications of FWW-EH Unit (Four-Pipe System with 3+1 Rows of Coils)

		Model	FWW200EH	FWW300EH	FWW400EH	FWW500EH	FWW600EH	FWW800EH	FWW1000EH	FWW1200EH	
Performance	Rated air flow (12Pa, 30Pa, 50Pa)	H	340	510	660	850	1020	1360	1700	2040	
		M	255	355	510	640	765	1040	1290	1550	
		L	170	255	340	425	510	660	850	1020	
Cooling capacity (W)	Total cooling capacity	H	2250	3310	4100	5000	5890	8010	9290	11200	
	Sensible cooling capacity	H	1490	2250	2850	3600	4300	5850	7080	8500	
Heating capacity (W)		H	2000	2900	3600	4650	5000	7000	8450	9800	
Rated power (W)	ESP: 12Pa	H	17	23	35	42	55	70	99	137	
		M	10	14	19	19	26	36	51	65	
		L	6	8	10	8	13	18	23	27	
	ESP: 30Pa	H	22	30	43	53	67	88	118	160	
		M	13	17	22	23	33	43	60	75	
		L	7	9	11	10	14	21	26	31	
	ESP: 50Pa	H	28	39	54	66	80	107	142	188	
		M	15	21	27	28	39	53	70	87	
		L	8	10	13	11	16	23	29	35	
	Operating current (A)	ESP: 12Pa	H	0.15	0.20	0.27	0.36	0.51	0.59	0.86	1.04
		ESP: 30Pa	H	0.19	0.25	0.35	0.46	0.60	0.73	1.01	1.20
		ESP: 50Pa	H	0.24	0.32	0.44	0.57	0.72	0.88	1.18	1.40
Noise (dB(A))	ESP: 12Pa	H	34.0	36.0	37.5	39.5	44.5	44.5	46.5	48.5	
		M	28.5	29.0	31.0	32.0	36.5	37.0	39.5	41.0	
		L	22.5	22.0	23.5	22.0	26.0	28.5	29.5	31.0	
	ESP: 30Pa	H	38.0	39.5	41.5	42.0	46.0	46.5	46.5	50.5	
		M	31.0	32.5	34.5	35.0	39.0	39.5	41.0	42.5	
		L	23.5	24.0	25.5	24.5	29.0	30.0	31.0	33.0	
	ESP: 50Pa	H	40.5	42.0	44.5	44.5	48.0	49.0	50.0	52.0	
		M	34.0	35.5	37.0	37.0	41.5	42.0	42.0	43.5	
		L	25.5	26.0	27.5	26.5	31.5	32.0	32.0	34.0	
	Water flow rate (m ³ /h)	Cooling by cooling coil		0.41	0.59	0.72	0.88	1.06	1.43	1.65	2.00
		Heating by heating coil		0.18	0.26	0.32	0.42	0.44	0.62	0.74	0.66
	Water resistance (kPa)	Cooling		12.0	27.0	15.0	22.0	33.0	34.0	28.0	42.0
Heating			5.0	110	18.0	31.0	7.0	15.0	21.0	30.0	
Coil	Type	Mechanical expansion joint of high-quality copper tubes with hyperbolic louver aluminum fins									
	Working pressure	1.6MPa									
Fan	Type	Centrifugal (Forward)									
	Qty	1	2	2	2	2	3	4	4		
Motor	Type	Single-phase capacitor motor configured with the sealed ball bearing with high precision and low noises									
	Qty	1	1	1	1	1	2	2	2		
	Power supply	220V-/50Hz									
	Protection grade	IP44									
	Insulation grade	B									
Water Inlet/outlet pipe	Size of pipe connector	Internal thread of Rc 3/4 taper pipe									
Condensate pipe	Size of pipe connector	External thread of R3/4 taper pipe									
Dimension (mm)	Width (C/B/D)	675	815	915	995	1095	1425	1525	1725		
	Depth (C/B/D)	465/516/497									
	Height (C/B/D)	235									
Net weight (kg)	Without the return air plenum	13.5	17.0	18.5	19.5	20.5	30.6	33.0	38.0		
	With the return air plenum	16.2	20.3	22.2	23.5	24.8	36.3	39.1	44.9		

Note:

- The cooling capacity (cooling coil) is measured when the air inlet dry bulb/wet bulb temperature is 27°C/19.5°C and the water inlet/outlet temperature is 7°C/12°C.
- The heating capacity (heating coil) is measured when the air inlet dry bulb is 21°C and the water inlet/outlet temperature is 60°C/50°C.
- The rated air flow is measured in the standard air and dry coil condition (dry bulb temperature: 20°C).
- The sound pressure level (SPL) noise value is obtained in a semi-anechoic room with the background level: 11.5 dB(A) based on the unit without the return air plenum and filter (compliance with GB/T19232-2003).
- H, M, and L indicate high, medium, and low fan speeds respectively; the unit default mode is cooling/heating four-pipe system; the static pressure refers to the static pressure at the unit outlet.
- Performance parameters in the preceding table are all obtained under the 220 V/50 Hz power supply.
- The left/right pipe connection direction can be changed on the jobsite for the unit. After connection direction change, multiply the cooling/heating capacity by the correction factor 0.85~0.9.
- The air flow, rated cooling and heating capacity in the preceding table are obtained based on the unit without the return air plenum and filter. For a unit with the back/bottom return air plenum, multiply the preceding values by the correction factor 0.92~95.
- Conditions for noise test: 1m*1m under the lateral bottom of air outlet; In actual installation, the obtained noise value may be different from that in the preceding table due to background noise or other reasons. The noise value of the unit with air return at the bottom is a little higher than that with air return at the back.

Outlines and Dimensions

Right connection, without return air plenum

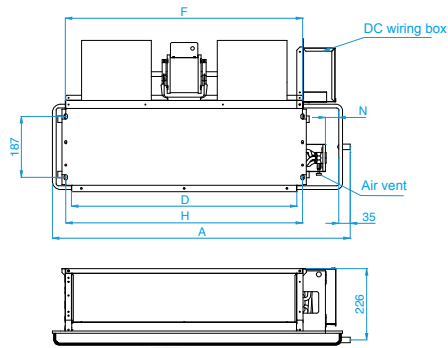

Right view of two-pipe system DC unit (EC)

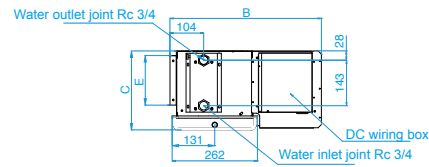

Right view of four-pipe system DC unit (EH)

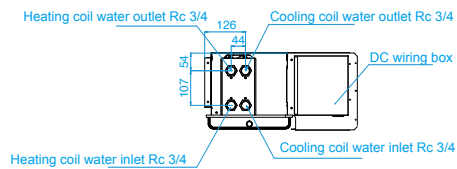

Right connection, with back return air plenum

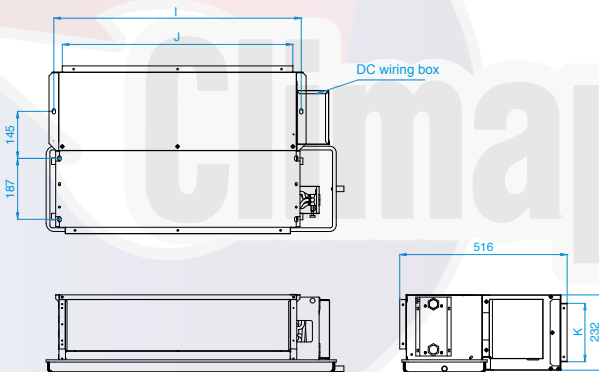

Right connection, with bottom return air plenum

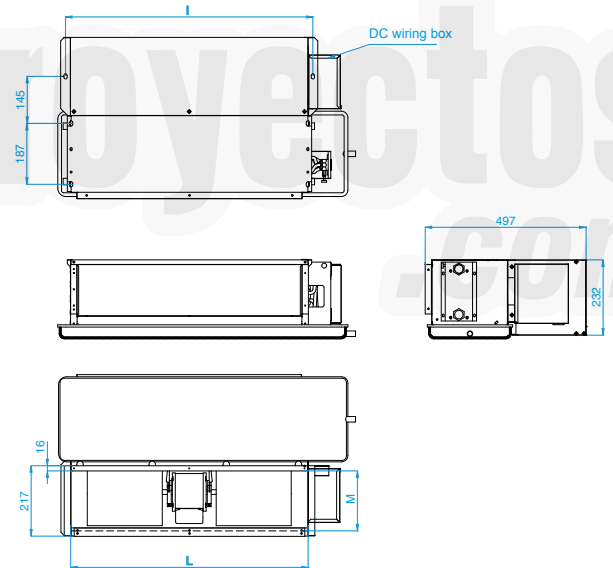

Note: 1. Water pipe connection is the same for the unit with or without the return air plenum;
 2. Other unmarked dimensions of the unit are the same with those of the unit without the return air plenum;
 3. Dimensions of the unit of left connected pipe are the same with those of the unit of right connected pipe in the preceding diagram symmetrically.

Model	A		D	F	H	I	J	L	N	
	Standard drain pan	Extended drain pan							Standard drain pan	Extended drain pan
FWW200	675	775	452	490	487	522	470	491	40	140
FWW300	815	915	592	630	627	662	610	631	40	140
FWW400	915	1015	692	730	727	762	710	731	40	140
FWW500	995	1095	772	810	807	842	790	811	40	140
FWW600	1095	1195	872	910	907	942	890	911	40	140
FWW800	1425	1525	1202	1240	1237	1272	1220	1241	40	140
FWW1000	1525	1625	1302	1340	1337	1372	1320	1341	40	140
FWW1200	1725	1825	1502	1540	1537	1572	1520	1541	40	140
FWW1400	1985	2085	1762	1800	1797	1832	1780	1801	40	140

Note: In the table, the lengthened drain pan is the standard condensate drain pan lengthened by 100mm.

A	Total length of unit
B	Total width of unit (465)
C	Total height of unit (235)
D	Length of air outlet
E	Height of air outlet (151)
F	Width of air return duct
G	Height of air return duct (230)
H	Hole distance of hanging rod
I	Hoist hole distance of return air plenum
J	Units with back plenum, length of air outlet
K	Units with back plenum, height of air outlet (180)
L	Units with bottom plenum, length of air outlet
M	Units with bottom plenum, width of air outlet (185)
N	Distance between the surface of valve plate and the inner side of drain pan

Note: The data within the brackets in the table indicates that the dimensions of all the units are the same (unit: mm).

Exploded view of DC brushless fan coil unit

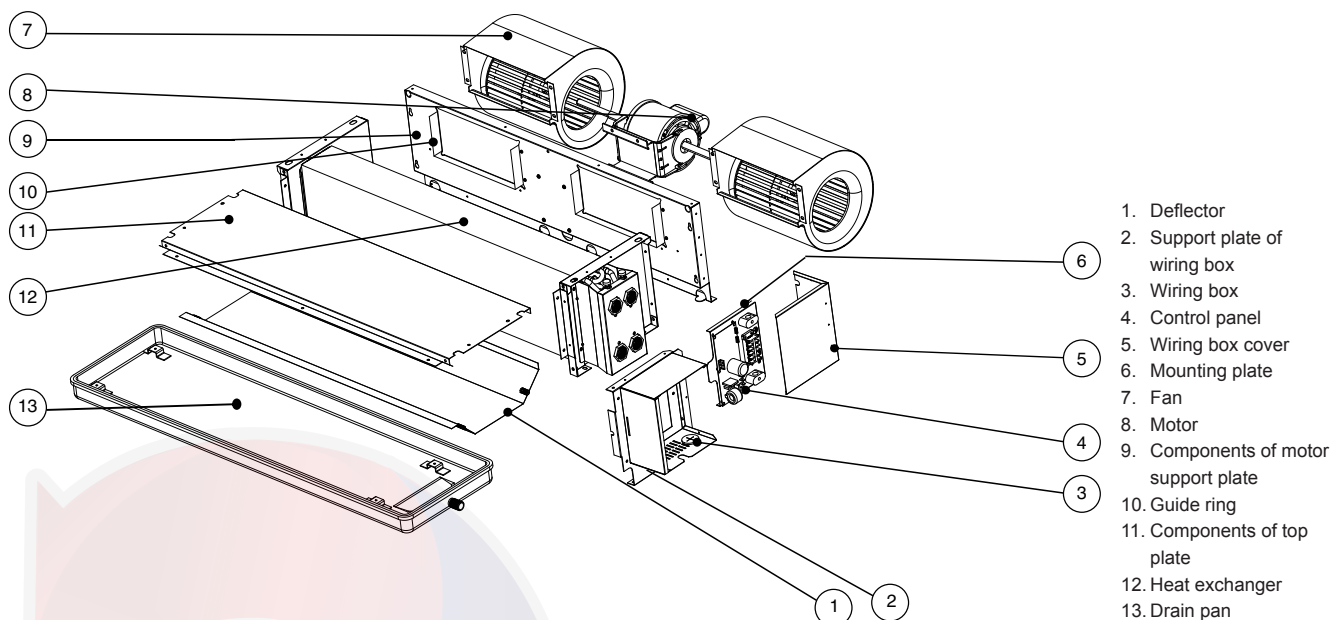

Note: The FWW500EH unit is shown in the diagram, without the return air plenum and filter

FWW-EC

Correction factor of cooling capacity

Model		200	300	400	500	600	800	1000	1200	1400
Medium speed	Total capacity	0.81	0.82	0.81	0.82	0.83	0.82	0.84	0.84	0.84
	Sensible capacity	0.75	0.79	0.78	0.78	0.80	0.79	0.81	0.81	0.82
Low speed	Total capacity	0.59	0.60	0.59	0.61	0.58	0.61	0.63	0.64	0.63
	Sensible capacity	0.50	0.54	0.53	0.56	0.56	0.56	0.58	0.58	0.58

Correction factor of heating capacity

Medium	0.77	0.80	0.80	0.80	0.81	0.80	0.81	0.82	0.83
Low	0.53	0.56	0.57	0.57	0.59	0.57	0.59	0.60	0.60

FWW-EH

Correction factor of cooling capacity

Model		200	300	400	500	600	800	1000	1200
Medium speed	Total capacity	0.81	0.83	0.82	0.84	0.83	0.83	0.84	0.84
	Sensible capacity	0.77	0.80	0.79	0.80	0.80	0.80	0.81	0.81
Low speed	Total capacity	0.60	0.62	0.61	0.63	0.63	0.63	0.63	0.64
	Sensible capacity	0.50	0.56	0.56	0.57	0.57	0.57	0.58	0.58

Correction factor of heating capacity (cooling coil)

Medium	0.78	0.82	0.80	0.81	0.81	0.80	0.82	0.81
Low	0.53	0.56	0.57	0.59	0.59	0.71	0.60	0.60

Correction factor of cooling capacity (heating coil)

Medium	0.84	0.86	0.86	0.86	0.86	0.86	0.86	0.86
Low	0.62	0.68	0.68	0.68	0.68	0.68	0.68	0.68

Wiring Diagrams

Model: FWW200-1400EC/EH

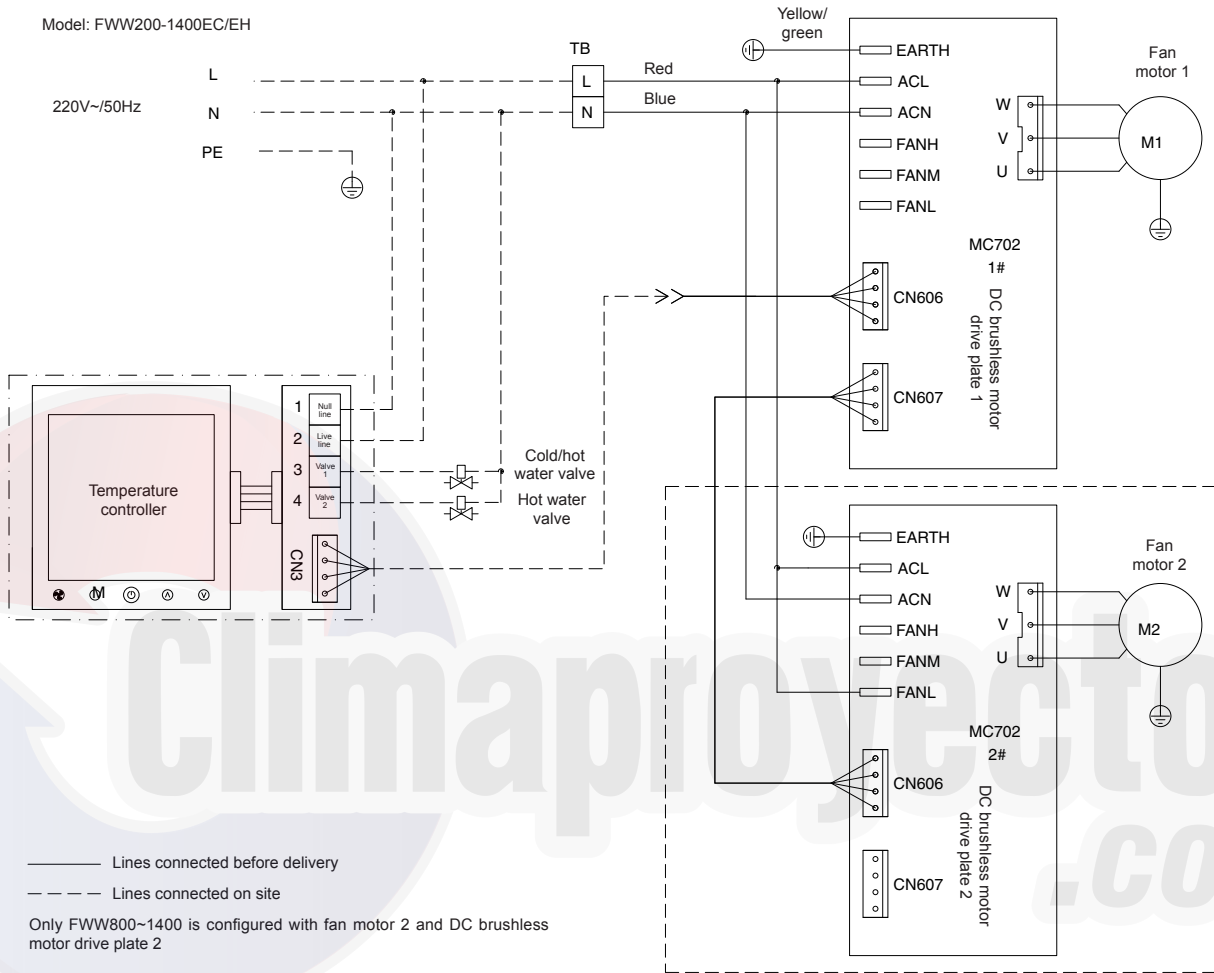

Model code	Type	Temperature controller	Valve 1	Valve 2
EC	Cooling/heating two-pipe type	AC2981A-2	Cold/hot	/
EH	Cooling/heating four-pipe type	AC2981A-4	Cold	Hot

Air flow and static pressure curve (suitable for FWW-EC/EH series units)

Outlet static pressure 30Pa H speed

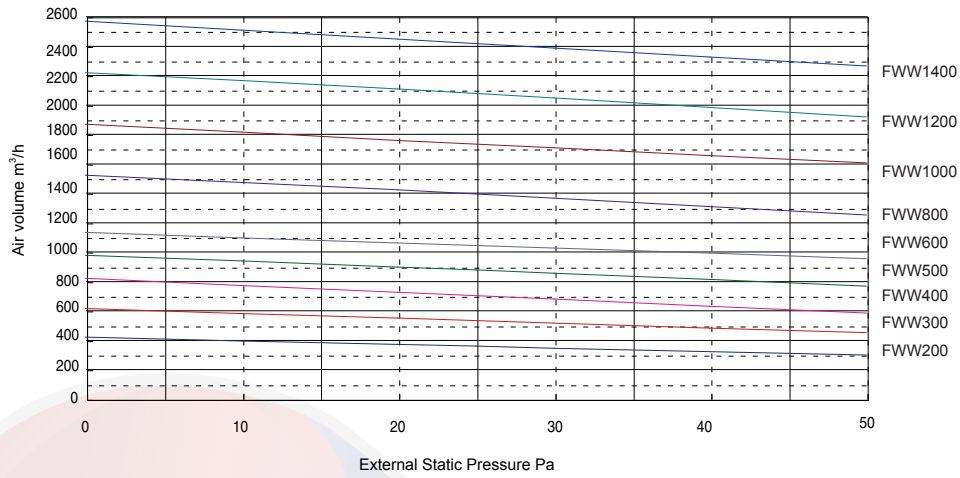

External Static Pressure 30Pa M speed

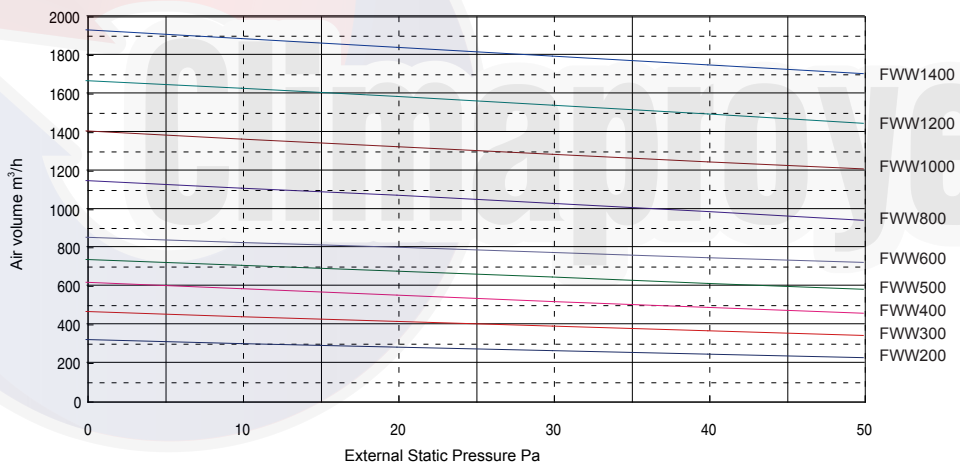

External Static Pressure 30Pa L speed

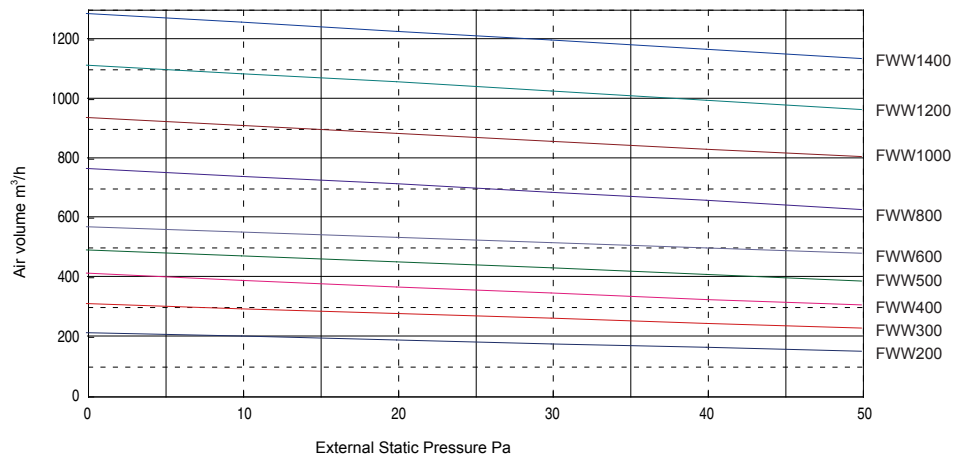

Note: Please see model selection software for the air flow and static pressure curve of other static pressures.

Installation Diagram

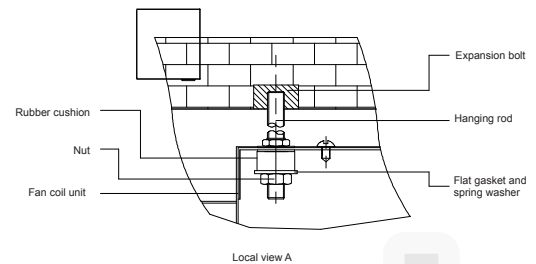
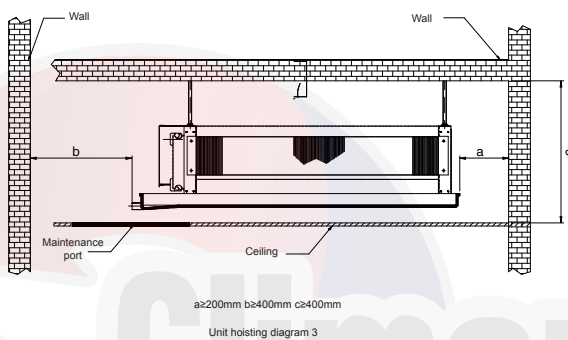
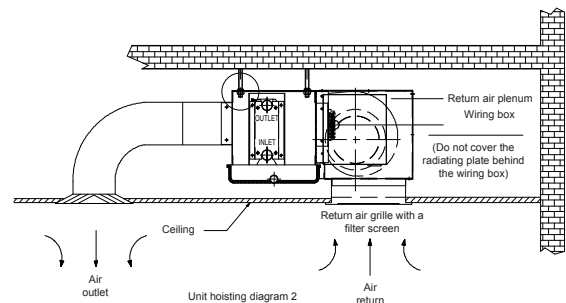
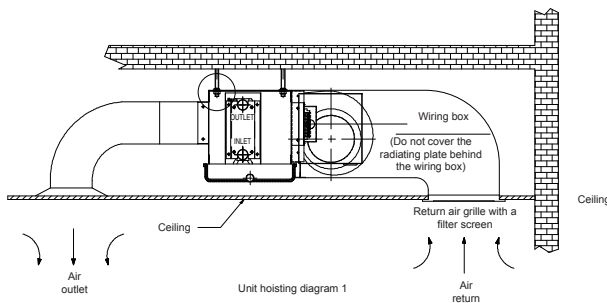

AC2981



AC2981 series

- Touchable key temperature controller, manual five-step speed, automatic stepless speed regulation, one button for energy saving, anti-freezing protection and button locking;
- Touchable key is more user-friendly and consistent with their operating habits, and the operating experience is enhanced;
- Special temperature controller AC2981 and DC brushless fan coil work together to enable much more flexible control.



Three-wire electric 2-/3-way globe valve DQF-B series

- Excellent water-proof, dust-proof, and tightness (IP65), straight through water flow without blocking, with a KVS value far higher than a common two-way valve;
- Flexible valve opening efficiently prevents water hammers, and big differential pressure upon closing realizes tight closing;
- The power-on time is very short, so the product saves more energy and the motor has a longer service life.



ATM02 series

- Electronic temperature controller; three steps of air speeds; double effects of the thermometer and temperature controller; power-off memory; two-/four-pipe system and two-/three-wire valve are optional;
- The two-way infrared remote control facilitates the operation;
- With a small size, the unit does not occupy much space in installation and meets the needs for different decoration styles.



Electric 2-/3-way valve FCV series

- A new kind of FCV driver is specially designed to match the valve body and can be applied to multiple cooling and heating coil control systems conveniently and reliably, making installation easy;
- Multiple voltages can be selected for the driver. In addition, the synchronous motor and spring resetting functions are also provided, making the operation process convenient.

Warning



- Daikin Industries, Ltd.'s products are manufactured for export to numerous countries throughout the world. Daikin Industries, Ltd. does not have control over which products are exported to and used in a particular country. Prior to purchase, please therefore confirm with your local authorized importer, distributor and/or retailer whether this product conforms to the applicable standards, and is suitable for use, in the region where the product will be used. This statement does not purport to exclude, restrict or modify the application of any local legislation.
- Ask a qualified installer or contractor to install this product. Do not try to install the product yourself. Improper installation can result in water or refrigerant leakage, electrical shock, fire or explosion.
- Use only those parts and accessories supplied or specified by Daikin. Ask a qualified installer or contractor to install those parts and accessories. Use of unauthorized parts and accessories or improper installation of parts and accessories can result in water or refrigerant leakage, electrical shock, fire or explosion.
- Read the User's Manual carefully before using this product. The User's Manual provides important safety instructions and warnings. Be sure to follow these instructions and warnings.

If you have any enquiries, please contact your local importer, distributor and/or retailer.



The air conditioners manufactured by Daikin Industries have received **ISO 9001 series** certification for quality assurance.

Certificate Number. 9601019



The airconditioning factories of Daikin Industries have received environmental management system standard **ISO 14001** certification.

Certificate Number. EMS80362

Cautions on product corrosion

1. The units should not be installed in areas where corrosive gases, such as acid gas or alkaline gas, are produced.
2. If the unit is to be installed close to the sea shore, direct exposure to the sea breeze should be avoided. If you need to install the unit close to the sea shore, contact your local distributor.

DAIKIN INDUSTRIES, LTD.

Head Office:
Umeda Center Bldg., 2-4-12, Nakazaki-Nishi,
Kita-ku, Osaka, 530-8323 Japan

Tokyo Office:
JR Shinagawa East Bldg., 2-18-1, Konan,
Minato-ku, Tokyo, 108-0075 Japan

http://www.daikin.com/global_ac/

© All rights reserved

Printed with soy ink.

Literature No.: ED-FWW-EC/EH-201609

Supersedes: ED-FWW-E-201607