

Goodman® TECHNICAL MANUAL

GMS8 33-3/8" 80% Gas Furnace Units 80% AFUE, Single Stage, Multi-Speed, Upflow Horizontal

- Refer to Service Manual RS6612006 for troubleshooting information.
- All safety information must be followed as provided in the Service Manual.
- Refer to the appropriate Parts Catalog for part number information.
- Model numbers listed on page 3.

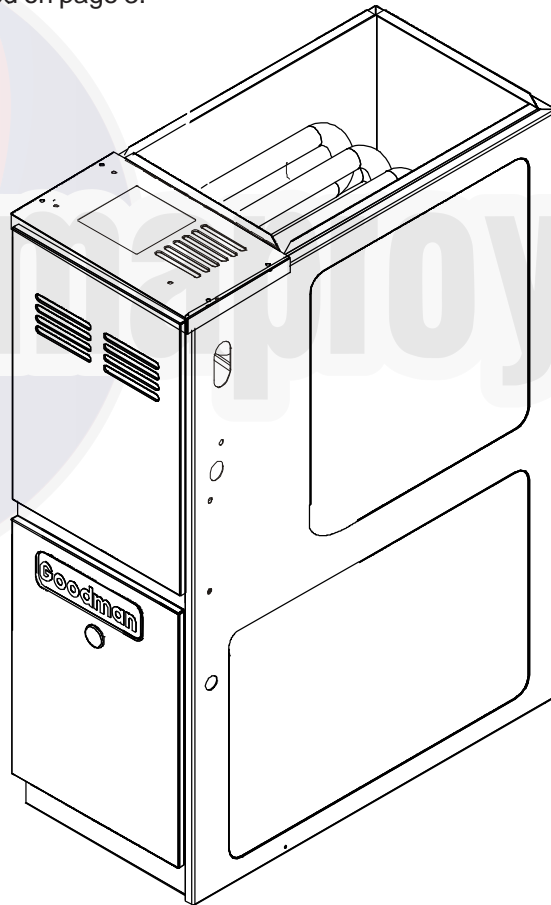

This manual is to be used by qualified, professionally trained HVAC technicians only. Goodman does not assume any responsibility for property damage or personal injury due to improper service procedures performed by an unqualified person.

RT6622014r3
November 2013

PRODUCT IDENTIFICATION

The model and manufacturing number are used for positive identification of component parts used in manufacturing. Please use these numbers when requesting service or parts information.

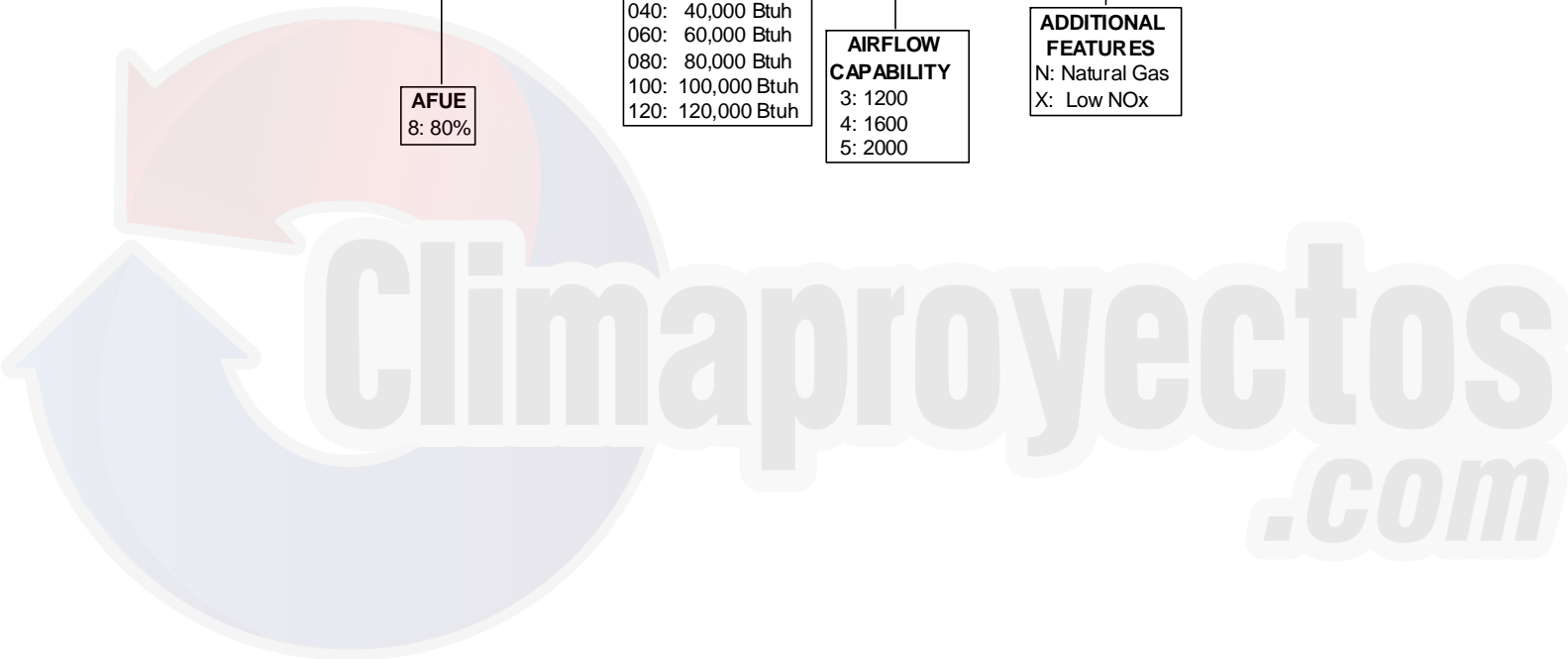
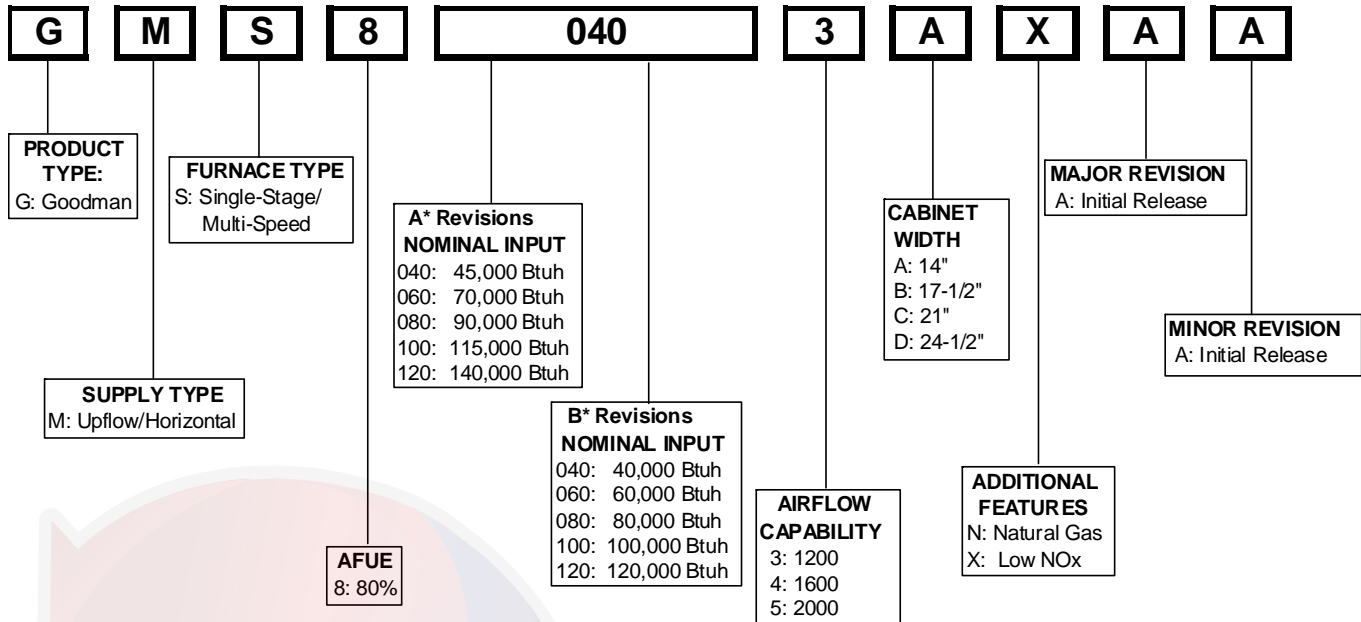

WARNING

HIGH VOLTAGE!
Disconnect ALL power before servicing or installing this unit. Multiple power sources may be present. Failure to do so may cause property damage, personal injury or death.

WARNING

Goodman will not be responsible for any injury or property damage arising from improper service or service procedures. If you install or perform service on this unit, you assume responsibility for any personal injury or property damage which may result. Many jurisdictions require a license to install or service heating and air conditioning equipment.

WARNING

Installation and repair of this unit should be performed ONLY by individuals meeting the requirements of an "entry level technician" as specified by the Air-Conditioning, Heating, and Refrigeration Institute (AHRI). Attempting to install or repair this unit without such background may result in product damage, personal injury or death.

PRODUCT IDENTIFICATION

The model and manufacturing number are used for positive identification of component parts used in manufacturing. Please use these numbers when requesting service or parts information.

GMS80403A*A*
GMS80603A*A*
GMS80604B*A*
GMS80804B*A*
GMS80805C*A*
GMS81005C*A*
GMS81205D*A

GMS80403A*B*
GMS80603A*B*
GMS80604B*B*
GMS80804B*B*
GMS80805C*B*
GMS81005C*B*
GMS81205D*B*

**These models available in Natural Gas and Low NOx.*

Climaproyectos
.com

 **WARNING**

The United States Environmental Protection Agency (“EPA”) has issued various regulations regarding the introduction and disposal of refrigerants introduced into this unit. Failure to follow these regulations may harm the environment and can lead to the imposition of substantial fines. These regulations may vary by jurisdiction. Should questions arise, contact your local EPA office.

 **WARNING**

Do not connect or use any device that is not design certified by Goodman for use with this unit. Serious property damage, personal injury, reduced unit performance and/or hazardous conditions may result from the use of such non-approved devices.

 **WARNING**

To prevent the risk of property damage, personal injury, or death, do not store combustible materials or use gasoline or other flammable liquids or vapors in the vicinity of this appliance.

PRODUCT DESIGN

General Operation

The GMS8 furnaces are equipped with an electronic ignition device used to light the burners and an induced draft blower to exhaust combustion products.

An interlock switch prevents furnace operation if the inner blower door is not in place. Keep the blower access door in place except for inspection and maintenance. (See illustration on pages 5 and 6.)

This furnace is also equipped with a self-diagnosing electronic control module. In the event a furnace component is not operating properly, the control module LED will flash on and off in a factory-programmed sequence, depending on the problem encountered. This light can be viewed through the observation window in the blower access door. Refer to the *Troubleshooting Chart* for further explanation of the LED codes and *Abnormal Operation - Integrated Ignition Control* section in the Service Instructions for an explanation of the possible problem.

The rated heating capacity of the furnace should be greater than or equal to the total heat loss of the area to be heated. The total heat loss should be calculated by an approved method or in accordance with "ASHRAE Guide" or "Manual J-Load Calculations" published by the Air Conditioning Contractors of America.

*Obtain from: American National Standards Institute 1430 Broadway New York, NY 10018

Location Considerations

- The furnace should be as centralized as is practical with respect to the air distribution system.
- Do not install the furnace directly on carpeting, tile, or combustible material other than wood flooring.
- When installed in a residential garage, the furnace must be positioned so the burners and ignition source are located not less than 18 inches (457 mm) above the floor and protected from physical damage by vehicles.

Notes:

 WARNING
<p>TO PREVENT POSSIBLE PERSONAL INJURY OR DEATH DUE TO ASPHYXIATION, THIS FURNACE MUST BE CATEGORY I VENTED. DO NOT VENT USING CATEGORY III VENTING.</p>

Category I Venting is venting at a non-positive pressure. A furnace vented as Category I is considered a fan-assisted appliance and the vent system does not have to be "gas tight." **NOTE:** Single stage gas furnaces with induced draft blowers draw products of combustion through a heat exchanger allowing, in some instances, common venting with natural draft appliances (i.e. water heaters). All installations must be vented in accordance with National Fuel Gas Code

NFPA 54/ANSI Z223.1 - latest edition. In Canada, the furnaces must be vented in accordance with the National Standard of Canada, CAN/CSA B149.1 and CAN/CSA B149.2 - latest editions and amendments.

NOTE: The vertical height of the Category I venting system must be at least as great as the horizontal length of the venting system.

Accessibility Clearances (Minimum)

Unobstructed front clearance of 24" for servicing is recommended.

MINIMUM CLEARANCE TO COMBUSTIBLE MATERIALS - INCHES

Sides	Rear	Front*	Vent		Top
			SW	B	
1	0	3	6	1	1

* 24" clearance for serviceability recommended.

** Single Wall Vent (SW) to be used only as a connector.

Refer to the venting tables outlined in the Installation Manual for additional venting requirements.

Note: In all cases accessibility clearance shall take precedence over clearances from the enclosure where accessibility clearances are greater. All dimensions are given in inches.

High Altitude Derate

IMPORTANT NOTE: The furnace as shipped requires no change to run between 0 - 4500 feet. Do not attempt to increase the firing rate by changing orifices or increasing the manifold pressure below 4500 feet. This can cause poor combustion and equipment failure.

High altitude installations above 4500 feet may require both a pressure switch and an orifice change. These changes are necessary to compensate for the natural reduction in the density of both the gas fuel and the combustion air at higher altitude.

For installations above 4500 feet, please refer to your distributor for required kit(s). Contact the distributor for a tabular listing of appropriate manufacturer's kits for propane gas and/or high altitude installations. The indicated kits must be used to insure safe and proper furnace operation. All conversions must be performed by a qualified installer, or service agency.

COMPONENT IDENTIFICATION

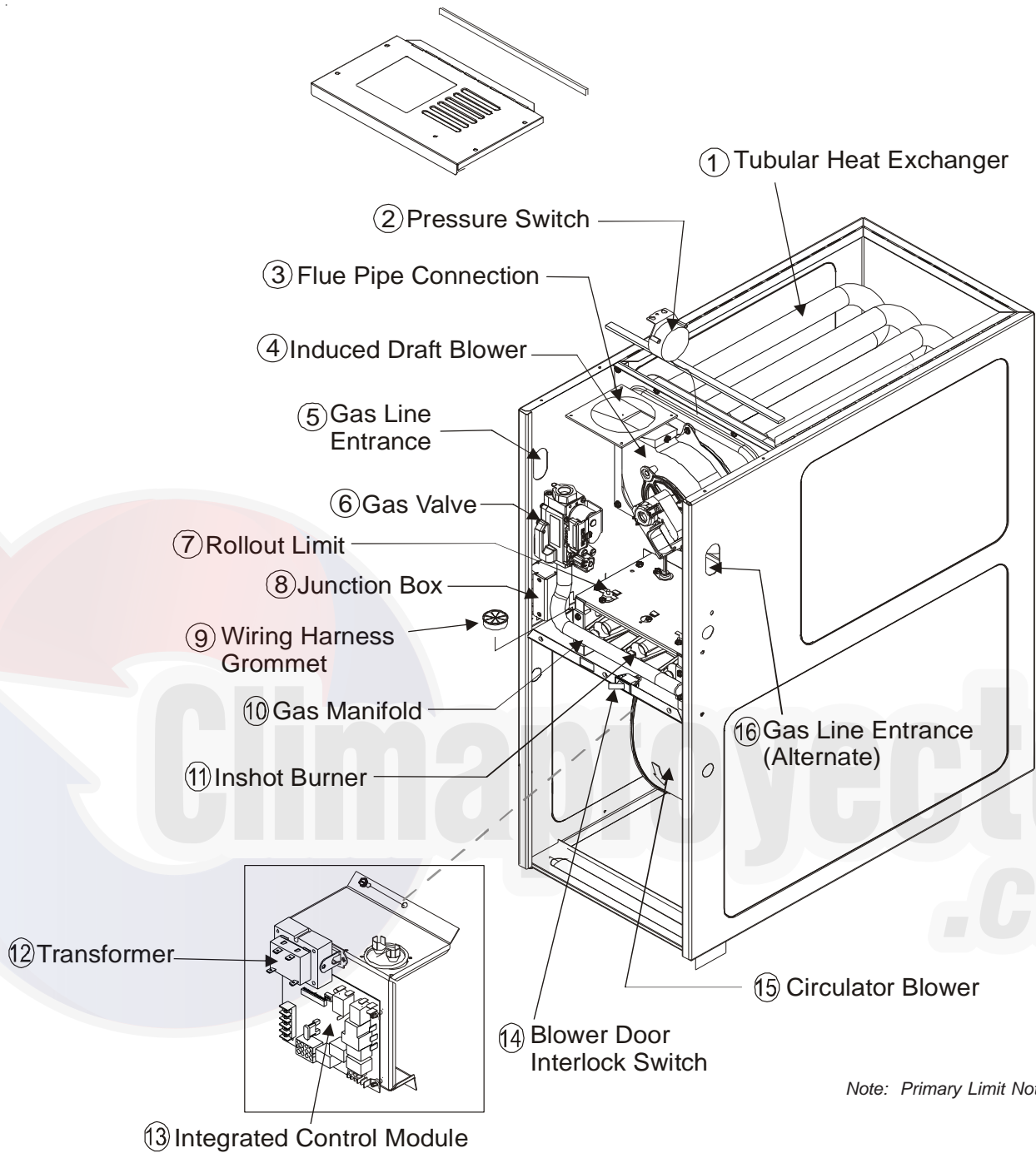

Upflow/Horizontal

- | | |
|--------------------------|----------------------------------|
| 1 Tubular Heat Exchanger | 9 Wiring Harness Grommet |
| 2 Pressure Switch | 10 Gas Manifold |
| 3 Flue Pipe Connection | 11 Inshot Burner |
| 4 Induced Draft Blower | 12 Transformer |
| 5 Gas Line Entrance | 13 Integrated Control Module |
| 6 Gas Valve | 14 Blower Door Interlock Switch |
| 7 Rollout Limit | 15 Circulator Blower |
| 8 Junction Box | 16 Gas Line Entrance (Alternate) |

PRODUCT DIMENSIONS

GMS8

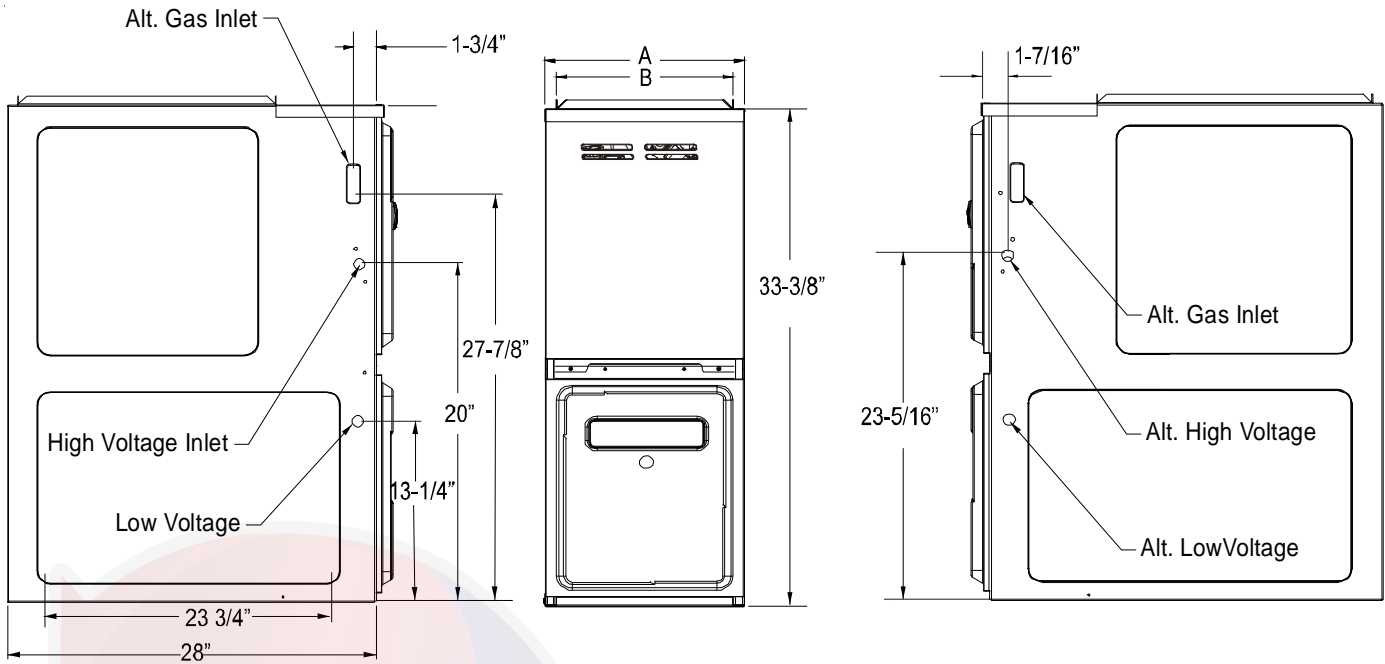

MODEL	A	B
GMS80403A***	14	12 - 1/2
GMS80603A***		
GMS80604B***	17 - 1/2	16
GMS80804B***		
GMS80805C***	21	19 - 1/2
GMS81005C***		
GMS81205D***	24 - 1/2	23

Pressure Switch Trip Points		
Model	Trip Point ID Blower Pressure Switch	ID Blower Pressure Switch Part #
GMS80403A*A*	-0.70	B1370158
GMS80603A*A*	-0.70	B1370158
GMS80604B*A*	-0.75	B1370179
GMS80804B*A*	-0.75	B1370179
GMS80805C*A*	-0.75	B1370179
GMS81005C*A*	-0.90	0130F00041
GMS81205D*A*	-0.80	0130F00042

For installations in Canada, the GMS furnaces are certified only to 4,500 ft.

* Negative pressure readings are in inches of water column (*w.c.)

PRIMARY LIMIT				
Part Number	0130F00035	20162906	20162903	0130F00036
Open Setting (°F)	220	170	160	180
GMS80403A*A*	1	---	---	---
GMS80603A*A*	---	1	---	---
GMS80604B*A*	---	1	---	---
GMS80804B*A*	---	---	1	---
GMS80805C*A*	---	1	---	---
GMS81005C*A*	---	---	---	1
GMS81205D*A*	---	---	1	---

ROLLOUT LIMIT SWITCHES	
Part Number	10123529
Open Setting (°F)	300
GMS80403A***	2
GMS80603A***	2
GMS80604B***	2
GMS80804B***	2
GMS80805C***	2
GMS81005C***	2
GMS81205D***	2

AUXILIARY LIMIT SWITCHES	
Part Number	0130F00038
Open Setting (°F)	120
GMS80403A***	1
GMS80603A***	1
GMS80604B***	1
GMS80804B***	1
GMS80805C***	1
GMS81005C***	1
GMS81205D***	1

Pressure Switch Trip Points		
Model	Trip Point ID Blower Pressure Switch	ID Blower Pressure Switch Part #
GMS80403A*B*	-0.80	0130F00042
GMS80603A*B*	-0.80	0130F00042
GMS80604B*B*	-0.90	0130F00041
GMS80804B*B*	-0.80	0130F00042
GMS80805C*B*	-0.80	0130F00042
GMS81005C*B*	-0.80	0130F00042
GMS81205D*B*	-0.80	0130F00042

For installations in Canada, the GMS furnaces are certified only to 4,500 ft.

* Negative pressure readings are in inches of water column (*w.c.)

PRIMARY LIMIT			
Part Number	20162901	20162904	20162903
Open Setting (°F)	210	150	160
GMS80403A*B*	1	---	---
GMS80603A*B*	---	1	---
GMS80604B*B*	---	1	---
GMS80804B*B*	---	1	---
GMS80805C*B*	---	---	1
GMS81005C*B*	---	1	---
GMS81205D*B*	---	---	1

ROLLOUT LIMIT SWITCHES	
Part Number	10123529
Open Setting (°F)	300
GMS80403A***	2
GMS80603A***	2
GMS80604B***	2
GMS80804B***	2
GMS80805C***	2
GMS81005C***	2
GMS81205D***	2

AUXILIARY LIMIT SWITCHES	
Part Number	0130F00038
Open Setting (°F)	120
GMS80403A***	1
GMS80603A***	1
GMS80604B***	1
GMS80804B***	1
GMS80805C***	1
GMS81005C***	1
GMS81205D***	1

PRODUCT DESIGN

Coil Matches:

A large array of Amana® brand coils are available for use with the GMS8 furnaces, in either upflow or horizontal applications. These coils are available in both cased and uncased models (with the option of field installed TXV expansion device). These 80% furnaces match up with the existing Amana® brand coils as shown below.

Coil Matches (for Goodman® units using R22 and R-410A):

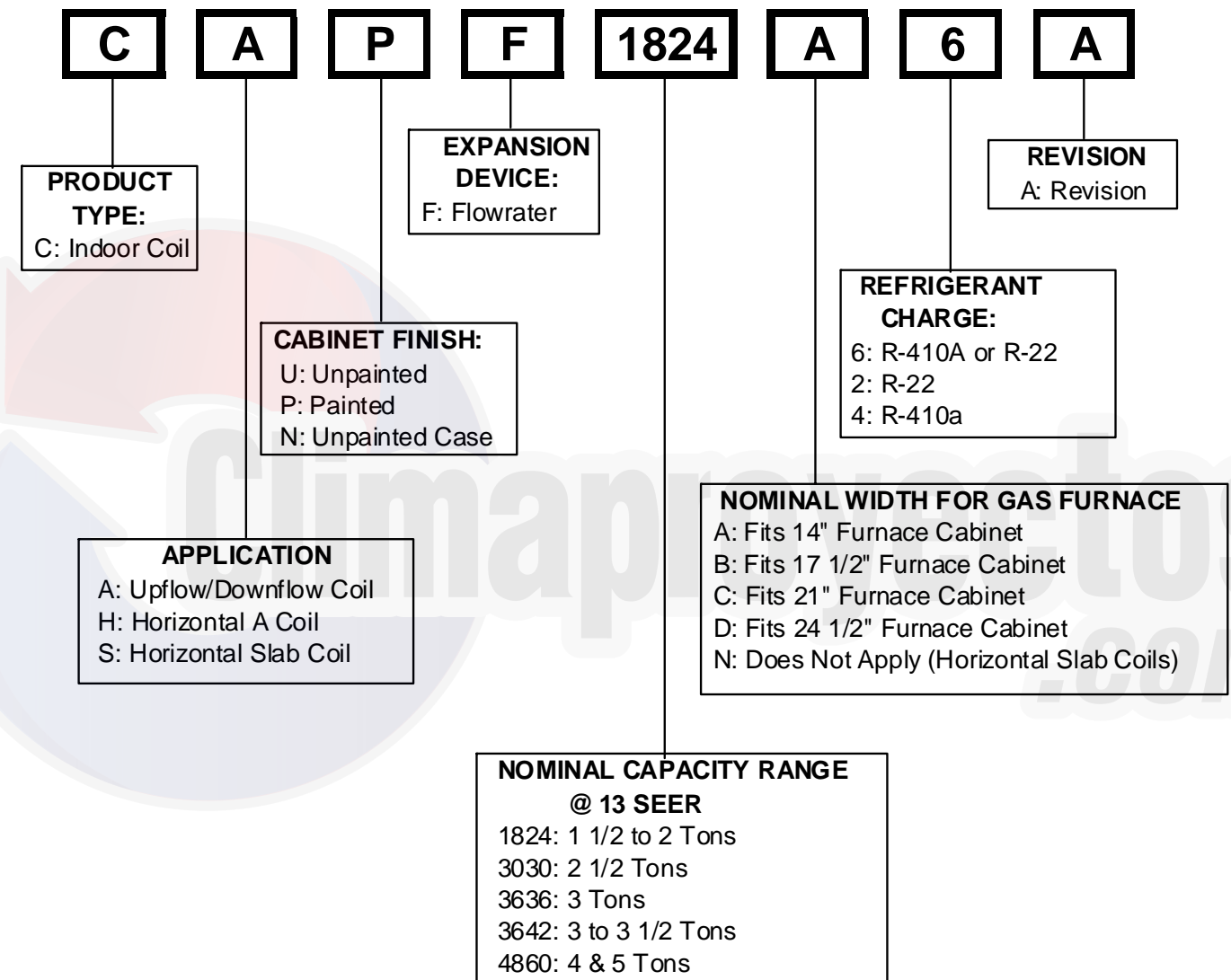

- All CAPF coils in B, C, & D widths have insulated blank off plates for use with one size smaller furnaces.
- All CAPF coils have a CAUF equivalent.
- All CHPF coils in B, C & D heights have an insulated Z bracket for use with one size smaller furnace.
- All proper coil combinations are subject to being ARI rated with a matched outdoor unit.

PRODUCT DESIGN

Thermostats:

It is recommended that a single-stage heat, non-power robbing thermostat be used. Refer to the product marketing literature for a complete list of thermostats offered.

Filters:

Filters are required with this furnace and must be provided by the installer. The filters used must comply with UL900 or CAN/ULCS111 standards. Installing this furnace without filters will void the unit warranty

Upflow Filters

SIDE RETURN		
Cabinet Width (in.)	Nominal Filter Size (in.)	Approx. Flow Area (in ²)
All	16 x 25 x 1	400

BOTTOM RETURN		
Cabinet Width (in.)	Nominal Filter Size (in.)	Approx. Flow Area (in ²)
17-1/2	14 x 25 x 1	350
21	16 x 25 x 1	400
24-1/2	20 x 25 x 1	500

Refer to Minimum Filter Area tables to determine filter area requirement. **NOTE:** Filters can also be installed elsewhere in the duct system such as a central return.

		UPFLOW COOLING AIRFLOW REQUIREMENT (CFM)						
		600	800	1000	1200	1400	1600	2000
Input_Airflow	0604_XA	--	---	564*	564*	672	768	
	0605_XA	--	---	---	752*	752*	768	960
	1005_XA	--	---	---	940*	940*	940*	960

		UPFLOW COOLING AIRFLOW REQUIREMENT (CFM)						
		600	800	1000	1200	1400	1600	2000
Input_Airflow	0604_XA	--	---	627*	627*	672	768	---
	0805_XA	--	---	---	836*	836*	836*	960
	1005_XA	--	---	---	940*	940*	940*	960

		COUNTERFLOW COOLING AIRFLOW REQUIREMENT (CFM)						
		600	800	1000	1200	1400	1600	2000
Input_Airflow	0604_XA	--	---	641*	641*	672	768	---
	0805_XA	--	---	---	854*	854*	854*	960

		COUNTERFLOW COOLING AIRFLOW REQUIREMENT (CFM)						
		600	800	1000	1200	1400	1600	2000
Input_Airflow	0604_XA	--	---	320*	320*	336	384	---
	0805_XA	--	---	---	427*	427*	427*	480

*Minimum filter area dictated by heating airflow requirement.

*Minimum filter area dictated by heating airflow requirement.

Disposable Minimum Filter Area (in²)
[Based on a 300 ft/min filter face velocity]

Permanent Minimum Filter Area (in²)
[Based on 600 ft/min filter face velocity]

FURNACE SPECIFICATIONS

GMS8***A*

MODEL	GMS80403A*A*	GMS80603A*A*	GMS80604B*A*	GMS80804B*A*	GMS80805C*A*	GMS81005C*A*	GMS81205D*A*
Btuh Input (US) High Fire	45,000	70,000	70,000	90,000	90,000	115,000	140,000
Output (US) High Fire	36,000	56,000	56,000	72,000	72,000	92,000	112,000
A.F.U.E.	80%	80%	80%	80%	80%	80%	80%
Rated External Static (" w.c.)	.20 - .50	.20 - .50	.20 - .50	.20 - .50	.20 - .50	.20 - .50	.20 - .50
Temperature Rise (°F)	25 - 55	25 - 55	20 - 50	35 - 65	35 - 65	35 - 65	40 - 70
High Stage Pressure Switch Trip Point (" w.c.)	-0.70	-0.70	-0.75	-0.75	-0.75	-0.90	-0.80
Blower Wheel (D" x W")	10 X 6	10 x 6	10 x 8	10X8	10x10	10X10	11x10
Blower Horsepower	1/3	1/3	1/2	1/2	1/2	1/2	3/4
Blower Speeds	4	4	4	4	4	4	4
Max CFM @ 0.5 E.S.P.	1298	1157	1883	1725	1960	1974	2131
Power Supply	115-60-1	115-60-1	115-60-1	115-60-1	115-60-1	115-60-1	115-60-1
Minimum Circuit Ampacity (MCA) ⁽¹⁾	8.5	8.5	12.9	12.9	12.9	12.9	15.2
Maximum Overcurrent Device ⁽²⁾	15	15	15	15	15	15	15
Transformer (VA)	40	40	40	40	40	40	40
Heat Anticipator (Amps)	0.7	0.7	0.7	0.7	0.7	0.7	0.7
Primary Limit Setting (°F)	220°	170°	170°	160°	170°	180°	160°
Auxiliary Limit Setting (°F)	120°	120°	120°	120°	120°	120°	120°
Rollout Limit Setting (°F)	300°	300°	300°	300°	300°	300°	300°
Gas Supply Pressure (Natural/Propane) (" w.c.)	7 / 11	7 / 11	7 / 11	7 / 11	7 / 11	7 / 11	7 / 11
Manifold Pressure (Natural/Propane) High Stage (" w.c.)	3.5 / 10	3.5 / 10	3.5 / 10	3.5 / 10	3.5 / 10	3.5 / 10	3.5 / 10
Orifice Size (Natural/Propane)	#43 / #55	#43 / #55	#43 / #55	#43 / #55	#43 / #55	#43 / #55	#43 / #55
Number of Burners	2	3	3	4	4	5	6
Vent Connector Diameter (inches) ⁽³⁾	4	4	4	4	4	4	4
Shipping Weight (lbs.)	120	130	143	153	163	170	183

⁽¹⁾ Wire size should be determined in accordance with National Electrical Codes. Extensive wire runs will require larger wire sizes.

⁽²⁾ Maximum Overcurrent Protection Device: May use Time Delay Fuse or HACR type Circuit Breaker of the same size as noted.

⁽³⁾ See Installation Instructions for appropriate vent diameter, length and number of elbows.

1. These furnaces are manufactured for natural gas operation. Optional Kits are available for conversion to propane gas operation.
2. For elevations above 2000 ft. the rating should be reduced by 4% for each 1000 ft. above sea level. The furnace must not be derated, orifice changes should only be made if necessary for altitude.
3. The total heat loss from the structure as expressed in TOTAL BTU/HR must be calculated by the manufactures method in accordance with the "A.S.H.R.A.E. GUIDE" or "MANUAL J-LOAD CALCULATIONS" published by the AIR CONDITIONING CONTRACTORS OF AMERICA. The total heat loss calculated should be equal to or less than the heating capacity. Output based on D.O.E. test procedures, steady state efficiency times output.
4. Minimum Circuit Ampacity calculated as: $(1.25 \times \text{Circulator Blower Amps}) + \text{I.D. Blower Amps}$.

Unit specifications are subject to change without notice. **ALWAYS** refer to the unit's serial plate for the most up-to-date general and electrical information.

FURNACE SPECIFICATIONS

GMS8***B*

MODEL	GMS80403A*B*	GMS80603A*B*	GMS80604B*B*	GMS80804B*B*	GMS80805C*B*	GMS81005C*B*	GMS81205D*B*
Btuh Input (US) High Fire	40,000	60,000	60,000	80,000	80,000	100,000	120,000
Output (US) High Fire	32,000	48,000	48,000	64,000	64,000	80,000	96,000
A.F.U.E.	80%	80%	80%	80%	80%	80%	80%
Rated External Static (" w.c.)	.20 - .50	.20 - .50	.20 - .50	.20 - .50	.20 - .50	.20 - .50	.20 - .50
Temperature Rise (°F)	25 - 55	25 - 55	20 - 50	35 - 65	35 - 65	35 - 65	40 - 70
High Stage Pressure Switch Trip Point (" w.c.)	-0.80	-0.80	-0.90	-0.80	-0.80	-0.80	-0.80
Blower Wheel (D" x W")	10 X 6	10 x 6	10 x 8	10X8	10x10	10X10	11x10
Blower Horsepower	1/3	1/3	1/2	1/2	1/2	1/2	3/4
Blower Speeds	4	4	4	4	4	4	4
Max CFM @ 0.5 E.S.P.	1298	1157	1883	1725	1960	1974	2131
Power Supply	115-60-1	115-60-1	115-60-1	115-60-1	115-60-1	115-60-1	115-60-1
Minimum Circuit Ampacity (MCA) ⁽¹⁾	8.5	8.5	12.9	12.9	12.9	12.9	15.2
Maximum Overcurrent Device ⁽²⁾	15	15	15	15	15	15	15
Transformer (VA)	40	40	40	40	40	40	40
Heat Anticipator (Amps)	0.7	0.7	0.7	0.7	0.7	0.7	0.7
Primary Limit Setting (°F)	210°	150°	150°	150°	160°	150°	160°
Auxiliary Limit Setting (°F)	120°	120°	120°	120°	120°	120°	120°
Rollout Limit Setting (°F)	300°	300°	300°	300°	300°	300°	300°
Gas Supply Pressure (Natural/Propane) (" w.c.)	7 / 11	7 / 11	7 / 11	7 / 11	7 / 11	7 / 11	7 / 11
Manifold Pressure (Natural/Propane) High Stage (" w.c.)	3.5 / 10	3.5 / 10	3.5 / 10	3.5 / 10	3.5 / 10	3.5 / 10	3.5 / 10
Orifice Size (Natural/Propane)	#45 / #55	#45 / #55	#45 / #55	#45 / #55	#45 / #55	#45 / #55	#45 / #55
Number of Burners	2	3	3	4	4	5	6
Vent Connector Diameter (inches) ⁽³⁾	4	4	4	4	4	4	4
Shipping Weight (lbs.)	120	130	143	153	163	170	183

⁽¹⁾ Wire size should be determined in accordance with National Electrical Codes. Extensive wire runs will require larger wire sizes.

⁽²⁾ Maximum Overcurrent Protection Device: May use Time Delay Fuse or HACR type Circuit Breaker of the same size as noted.

⁽³⁾ See Installation Instructions for appropriate vent diameter, length and number of elbows.

1. These furnaces are manufactured for natural gas operation. Optional Kits are available for conversion to propane gas operation.
2. For elevations above 2000 ft. the rating should be reduced by 4% for each 1000 ft. above sea level. The furnace must not be derated, orifice changes should only be made if necessary for altitude.
3. The total heat loss from the structure as expressed in TOTAL BTU/HR must be calculated by the manufactures method in accordance with the "A.S.H.R.A.E. GUIDE" or "MANUAL J-LOAD CALCULATIONS" published by the AIR CONDITIONING CONTRACTORS OF AMERICA. The total heat loss calculated should be equal to or less than the heating capacity. Output based on D.O.E. test procedures, steady state efficiency times output.
4. Minimum Circuit Ampacity calculated as: (1.25 x Circulator Blower Amps) + I.D. Blower Amps.

Unit specifications are subject to change without notice. **ALWAYS** refer to the unit's serial plate for the most up-to-date general and electrical information.

BLOWER PERFORMANCE SPECIFICATIONS

GMS8***A*

(CFM & Temperature Rise vs. External Static Pressure)															
Model Heating Speed As Shipped	Motor Speed	Tons AC at 0.5" ESP	EXTERNAL STATIC PRESSURE (Inches Water Column)												
			0.1		0.2		0.3		0.4		0.5		0.6	0.7	0.8
			CFM	RISE	CFM	RISE	CFM	RISE	CFM	RISE	CFM	RISE	CFM	CFM	CFM
*MS80403A*A* (MEDIUM)	HIGH	3.0	1521	22	1466	23	1414	24	1373	24	1298	26	1243	1164	1075
	MED	2.5	1160	29	1160	29	1132	29	1121	30	1082	31	1042	997	925
	MED-LO	2.0	961	35	955	35	948	35	932	36	913	37	882	821	803
	LOW	1.5	781	43	785	42	781	43	773	43	761	44	745	716	668
*MS80603A*A* (MEDIUM)	HIGH	3.0	1422	36	1352	38	1307	40	1197	43	1157	45	1092	1075	983
	MED	2.5	1098	47	1081	48	1051	49	1039	50	1021	51	983	924	868
	MED-LO	2.0	919	56	913	57	892	58	847	---	829	---	818	792	728
	LOW	1.5	758	---	741	---	741	---	733	---	699	---	677	649	626
*MS80604B*A* (MEDIUM)	HIGH	4.0	2134	---	2100	25	2042	25	1975	26	1883	28	1786	1700	1601
	MED	3.5	1668	31	1663	31	1656	31	1645	32	1616	32	1549	1492	1391
	MED-LO	3.0	1419	37	1426	36	1426	36	1432	36	1419	37	1378	1328	1261
	LOW	2.5	1134	46	1145	45	1166	44	1171	44	1160	45	1144	1111	1071
*MS80804B*A* (MEDIUM)	HIGH	4.0	2051	---	1983	---	1895	35	1812	37	1725	39	1627	1530	1439
	MED	3.5	1736	38	1708	39	1652	40	1611	41	1540	43	1475	1394	1307
	MED-LO	3.0	1493	45	1668	40	1459	46	1429	47	1389	48	1339	1274	1204
	LOW	2.5	1200	56	1185	56	1180	56	1173	57	1158	58	1125	1125	1080
*MS80805C*A* (MEDIUM)	HIGH	5.0	2290	---	2229	---	2155	---	2047	---	1960	---	1837	1712	1584
	MED	4.0	1852	36	1820	37	1777	38	1719	39	1641	41	1567	1469	1382
	MED-LO	3.5	1615	41	1592	42	1556	43	1516	44	1470	45	1405	1346	1235
	LOW	3.0	1290	52	1285	52	1265	53	1235	54	1214	55	1174	1044	904
*MS81005C*A* (MEDIUM)	HIGH	5.0	2323	37	2225	38	2120	40	2040	42	1974	43	1801	1688	1577
	MED	4.0	1858	46	1847	46	1799	47	1744	49	1674	51	1577	1493	1399
	MED-LO	3.5	1596	53	1587	54	1571	54	1552	55	1493	57	1397	1326	1217
	LOW	3.0	1291	---	1272	---	1261	---	1257	---	1205	---	1168	1118	1060
*MS81205D*A* (MEDIUM)	HIGH	5.0	2469	42	2389	43	2300	45	2223	47	2131	49	2027	1902	1786
	MED	4.0	1575	66	1558	67	1545	67	1513	69	1500	69	1419	1354	1271
	MED-LO	3.5	1402	---	1380	---	1343	---	1319	---	1296	---	1245	1183	1106
	LOW	3.0	1200	---	1186	---	1161	---	1127	---	1082	---	1042	995	926

NOTES:

- CFM in chart is without filter(s). Filters do not ship with this furnace, but must be provided by the installer.
- All furnaces ship as high-speed cooling. Installer must adjust blower cooling speed as needed.
- For most jobs, about 400 CFM per ton when cooling is desirable
- INSTALLATION IS TO BE ADJUSTED TO OBTAIN TEMPERATURE RISE WITHIN THE RANGE SPECIFIED ON THE RATING PLATE.
- The chart is for information only. For satisfactory operation, external static pressure must not exceed values shown on the rating plate. The shaded area insinuated ranges in excess of maximum static pressure allowed when heating.
- The dashed (---) areas indicate a temperature rise not recommended for this model.
- The above chart is for U.S. furnaces installed at 0' - 2,000'. At higher altitudes, a properly de-rated unit will have approximately the same temperature rise at a particular CFM, while ESP at the CFM will be lower.

BLOWER PERFORMANCE SPECIFICATIONS

GMS8***B*

(CFM & Temperature Rise vs. External Static Pressure)															
Model Heating Speed As Shipped	Motor Speed	Tons AC at 0.5" ESP	EXTERNAL STATIC PRESSURE (Inches Water Column)												
			0.1		0.2		0.3		0.4		0.5		0.6	0.7	0.8
			CFM	RISE	CFM	RISE	CFM	RISE	CFM	RISE	CFM	RISE	CFM	CFM	CFM
*MS80403A*B* (MEDIUM)	HIGH	3.0	1521	---	1466	----	1414	----	1373	----	1298	----	1243	1164	1075
	MED	2.5	1160	26	1160	26	1132	26	1121	26	1082	27	1042	997	925
	MED-LO	2.0	961	31	955	31	948	31	932	32	913	33	882	821	803
	LOW	1.5	781	38	785	38	781	38	773	38	761	32	745	716	668
*MS80603A*B* (MEDIUM)	HIGH	3.0	1422	31	1352	33	1307	34	1197	37	1157	38	1092	1075	983
	MED	2.5	1098	40	1081	41	1051	42	1039	43	1021	44	983	924	868
	MED-LO	2.0	919	48	913	49	892	50	847	----	829	----	818	792	728
	LOW	1.5	758	---	741	----	741	----	733	----	699	----	677	649	626
*MS80604B*B* (MEDIUM)	HIGH	4.0	2134	21	2100	21	2042	22	1975	23	1883	24	1786	1700	1601
	MED	3.5	1668	27	1663	27	1656	27	1645	27	1616	28	1549	1492	1391
	MED-LO	3.0	1419	31	1426	31	1426	31	1432	31	1419	31	1378	1328	1261
	LOW	2.5	1134	39	1145	39	1166	38	1171	38	1160	38	1144	1111	1071
*MS80804B*B* (MEDIUM)	HIGH	4.0	2051	---	1983	----	1895	----	1812	----	1725	----	1627	1530	1439
	MED	3.5	1736	---	1708	35	1652	36	1611	37	1540	38	1475	1394	1307
	MED-LO	3.0	1693	35	1668	36	1459	41	1429	41	1389	43	1339	1274	1204
	LOW	2.5	1200	49	1185	50	1180	50	1173	51	1158	51	1125	1125	1080
*MS80805C*B* (MEDIUM)	HIGH	5.0	2290	---	2229	----	2155	----	2047	----	1960	----	1837	1712	1584
	MED	4.0	1852	---	1820	----	1777	----	1719	---	1641	36	1567	1469	1382
	MED-LO	3.5	1615	37	1592	37	1556	38	1516	39	1470	40	1405	1346	1235
	LOW	3.0	1290	46	1285	46	1265	47	1235	48	1214	49	1174	1044	904
*MS81005C*B* (MEDIUM)	HIGH	5.0	2323	---	2225	----	2120	35	2040	36	1974	38	1801	1688	1577
	MED	4.0	1858	40	1847	40	1799	41	1744	42	1674	44	1577	1493	1399
	MED-LO	3.5	1596	46	1587	47	1571	47	1552	48	1493	50	1397	1326	1217
	LOW	3.0	1291	57	1272	58	1261	59	1257	59	1205	61	1168	1118	1060
*MS81205D*B* (MEDIUM)	HIGH	5.0	2469	---	2389	----	2300	----	2223	40	2131	42	2027	1902	1786
	MED	4.0	1575	56	1558	57	1545	58	1513	59	1500	59	1419	1354	1271
	MED-LO	3.5	1402	63	1380	64	1343	66	1319	67	1296	69	1245	1183	1106
	LOW	3.0	1200	---	1186	----	1161	----	1127	----	1082	----	1042	995	926

NOTES:

- CFM in chart is without filter(s). Filters do not ship with this furnace, but must be provided by the installer.
- All furnaces ship as high-speed cooling. Installer must adjust blower cooling speed as needed.
- For most jobs, about 400 CFM per ton when cooling is desirable
- INSTALLATION IS TO BE ADJUSTED TO OBTAIN TEMPERATURE RISE WITHIN THE RANGE SPECIFIED ON THE RATING PLATE.
- The chart is for information only. For satisfactory operation, external static pressure must not exceed values shown on the rating plate. The shaded area insicated ranges in excess of maximum static pressure allowed when heating.
- The dashed (---) areas indicate a temperature rise not recommended for this model.
- The above chart is for U.S. furnaces installed at 0' - 2,000'. At higher altitudes, a properly de-rated unit will have approximatley the same temperature rise at a particular CFM, while ESP at the CFM will be lower.

BLOWER PERFORMANCE SPECIFICATIONS

BTU OUTPUT vs TEMPERATURE RISE CHART

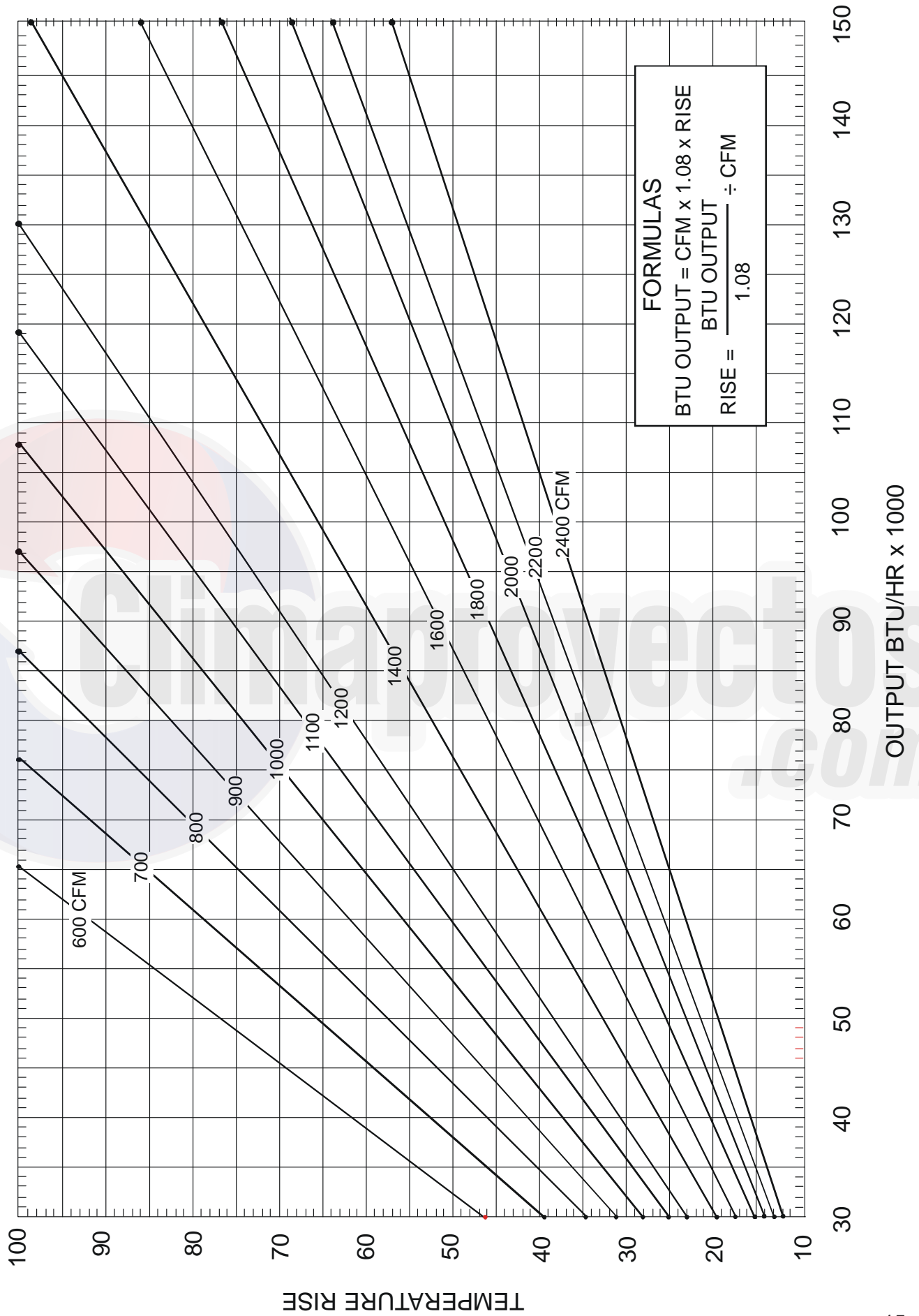

WARNING
HIGH VOLTAGE!
DISCONNECT ALL POWER BEFORE SERVICING OR INSTALLING THIS UNIT. MULTIPLE POWER SOURCES MAY BE PRESENT. FAILURE TO DO SO MAY CAUSE PROPERTY DAMAGE, PERSONAL INJURY OR DEATH.

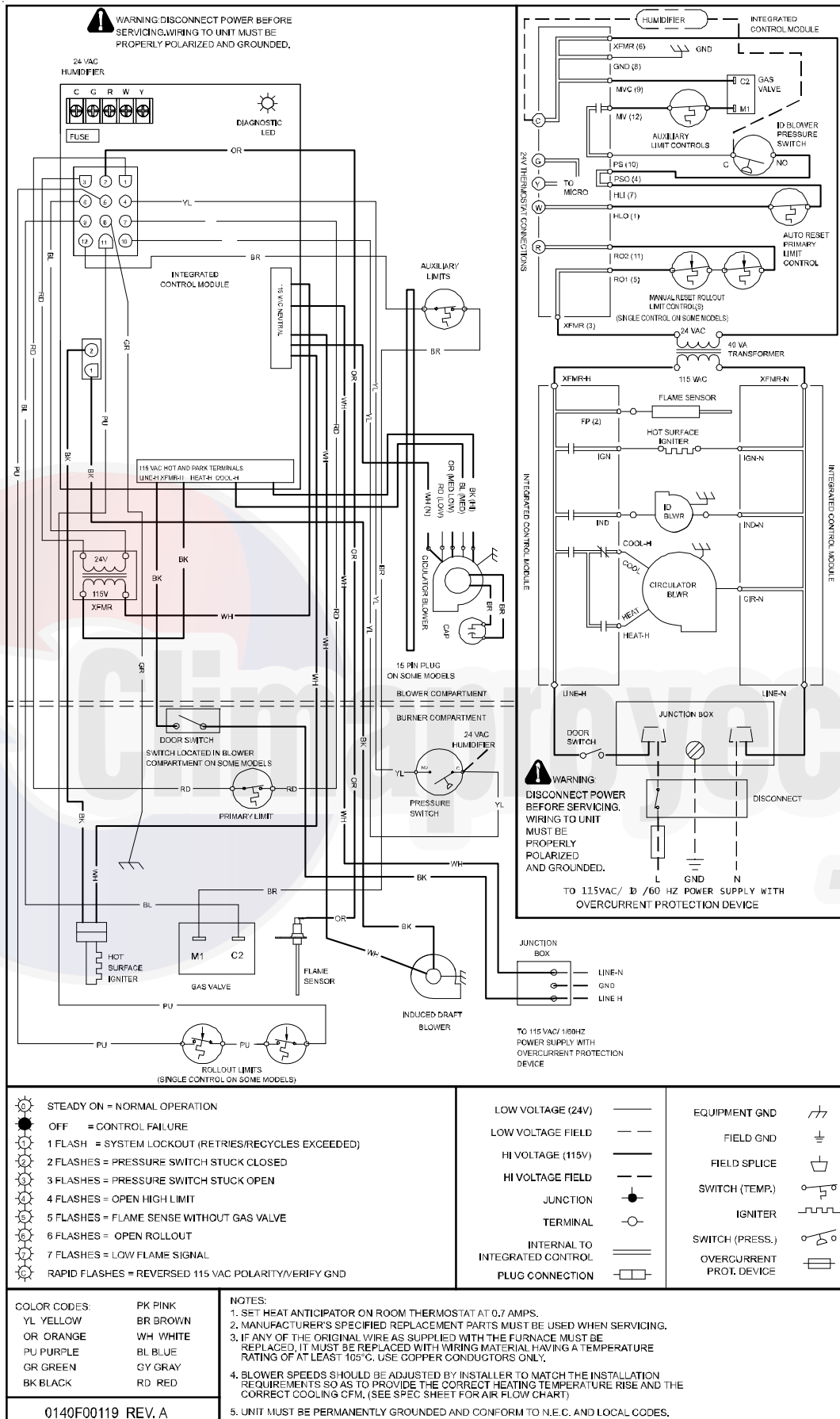

Wiring is subject to change, always refer to the wiring diagram on the unit for the most up-to-date wiring.

WARNING

HIGH VOLTAGE!
 DISCONNECT ALL POWER BEFORE SERVICING OR INSTALLING THIS UNIT. MULTIPLE POWER SOURCES MAY BE PRESENT. FAILURE TO DO SO MAY CAUSE PROPERTY DAMAGE, PERSONAL INJURY OR DEATH.

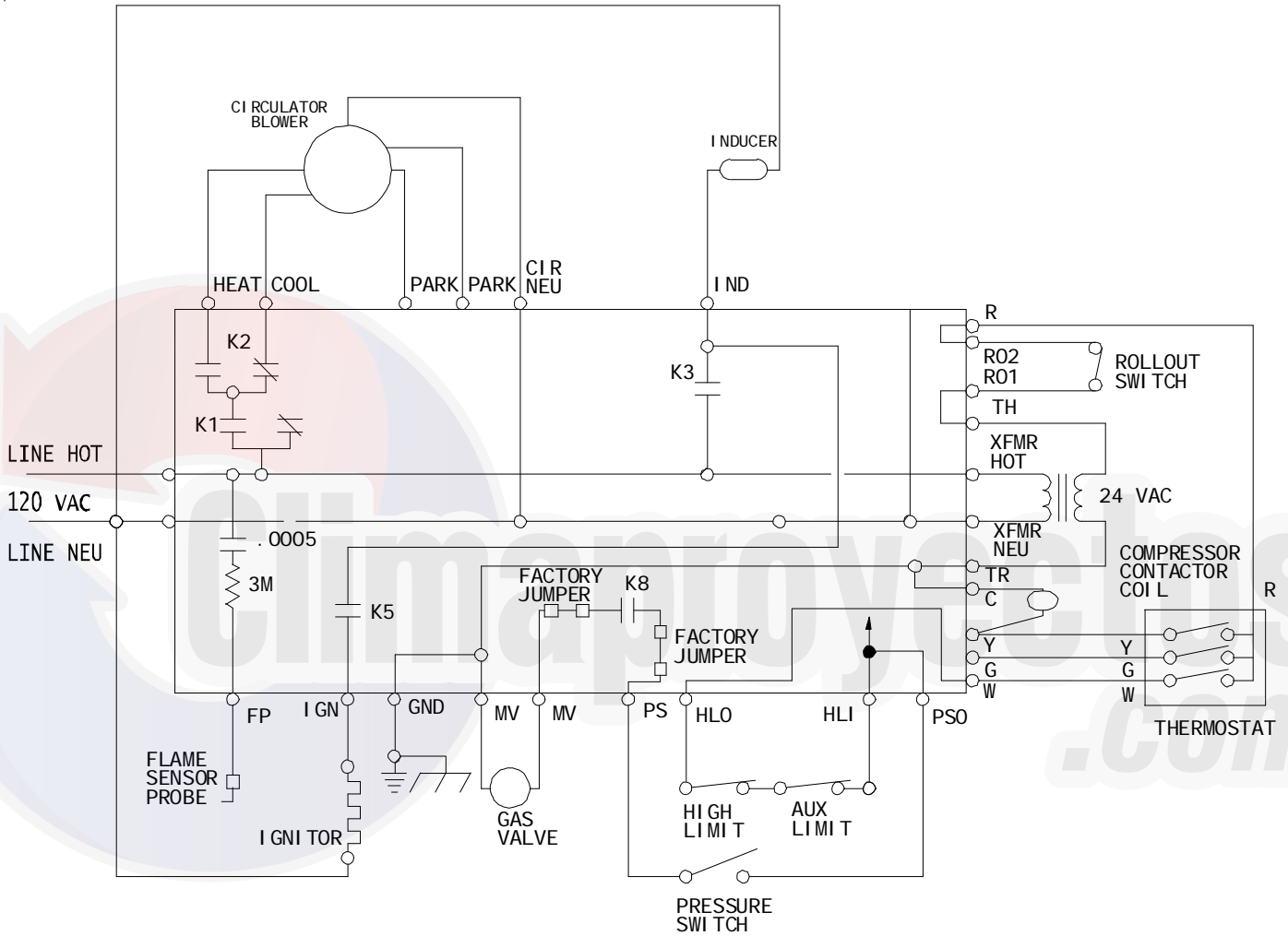

**TYPICAL SCHEMATIC
 GMS8 * MODEL FURNACES
 WR 50T55-289 INTEGRATED IGNITION CONTROL**

This schematic is for reference only. Not all wiring is as shown above. Always refer to the appropriate wiring diagram for the unit being serviced.