

# Service Manual

## TABLE OF CONTENTS

	PAGE
SAFETY CONSIDERATIONS .....	1
INTRODUCTION .....	1
MODEL/SERIAL NUMBER NOMENCLATURE .....	2
SPECIFICATIONS .....	3
DIMENSIONS .....	4
CLEARANCES .....	6
ELECTRICAL DATA .....	7
WIRING .....	7
CONNECTION DIAGRAM .....	7
WIRING DIAGRAMS .....	8
FAN AND MOTOR SPECIFICATIONS .....	10
REFRIGERATION CYCLE DIAGRAMS .....	11
REFRIGERANT LINES .....	12
SYSTEM EVACUATION AND CHARGING .....	13
SYSTEM VACUUM AND CHARGE .....	13
ELECTRONIC FUNCTIONS .....	14
TROUBLESHOOTING .....	16
DIAGNOSIS GUIDES .....	17
DIAGNOSIS AND SOLUTION .....	18
DISASSEMBLY INSTRUCTIONS .....	36

## SAFETY CONSIDERATIONS

Installing, starting up, and servicing air-conditioning equipment can be hazardous due to system pressures, electrical components, and equipment location (roofs, elevated structures, etc.).

Only trained, qualified installers and service mechanics should install, start-up, and service this equipment.

Untrained personnel can perform basic maintenance functions such as cleaning coils. All other operations should be performed by trained service personnel.

When working on the equipment, observe precautions in the literature and on tags, stickers, and labels attached to the equipment.

Follow all safety codes. Wear safety glasses and work gloves. Keep quenching cloth and fire extinguisher nearby when brazing. Use care in handling, rigging, and setting bulky equipment.

Read this manual thoroughly and follow all warnings or cautions included in literature and attached to the unit. Consult local building codes and National Electrical Code (NEC) for special requirements.

Recognize safety information. This is the safety-alert symbol . When you see this symbol on the unit and in instructions or manuals, be alert to the potential for personal injury. Understand these signal words: **DANGER**, **WARNING**, and **CAUTION**.

These words are used with the safety-alert symbol. **DANGER** identifies the most serious hazards which **will** result in severe personal injury or death. **WARNING** signifies hazards which **could** result in personal injury or death. **CAUTION** is used to identify unsafe practices which **may** result in minor personal injury or product and property damage. **NOTE** is used to highlight suggestions which **will** result in enhanced installation, reliability, or operation.

 **WARNING**

**ELECTRICAL SHOCK HAZARD**

Failure to follow this warning could result in personal injury or death.

Before installing, modifying, or servicing system, main electrical disconnect switch must be in the OFF position. There may be more than 1 disconnect switch. Lock out and tag switch with a suitable warning label.

 **WARNING**



**EXPLOSION HAZARD**

Failure to follow this warning could result in death, serious personal injury, and/or property damage.

Never use air or gases containing oxygen for leak testing or operating refrigerant compressors. Pressurized mixtures of air or gases containing oxygen can lead to an explosion.

 **CAUTION**

**EQUIPMENT DAMAGE HAZARD**

Failure to follow this caution may result in equipment damage or improper operation.

Do not bury more than 36 in. (914 mm) of refrigerant pipe in the ground. If any section of pipe is buried, there must be a 6 in. (152 mm) vertical rise to the valve connections on the outdoor units. If more than the recommended length is buried, refrigerant may migrate to the cooler buried section during extended periods of system shutdown. This causes refrigerant slugging and could possibly damage the compressor at start-up.

## INTRODUCTION

This Service Manual provides the necessary information to service, repair, and maintain the 38MBQ family of heat pumps. Section 2 of this manual has an appendix with data required to perform troubleshooting. Use the Table of Contents to locate a desired topic.

# MODEL/SERIAL NUMBER NOMENCLATURE

Table 1—Unit Sizes

SYSTEM TONS	kBTUh	VOLTAGE – PHASE	OUTDOOR MODEL
3.00	36	208/230-1	38MBQB36---3
4.00	48	208/230-1	38MBQB48---3

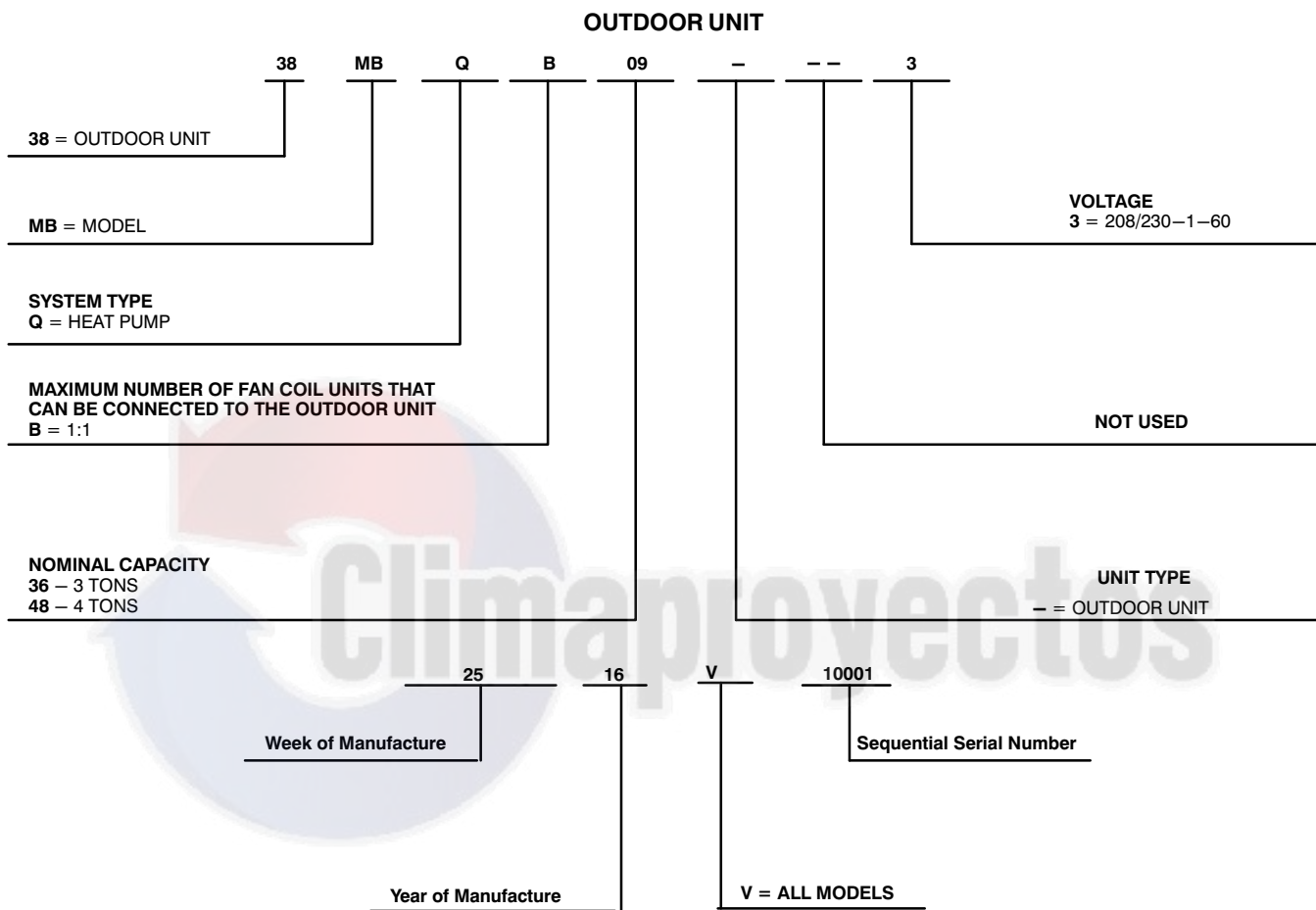

Use of the AHRI Certified TM Mark indicates a manufacturer's participation in the program. For verification of certification for individual products, go to [www.ahridirectory.org](http://www.ahridirectory.org).



# SPECIFICATIONS

Table 2—Specifications

SYSTEM	SIZE		36	48
	Outdoor Model		38MBQB36---3	38MBQB48---3
Electrical	Voltage, Phase, Cycle	V/Ph/Hz	208/230-1-60	208/230-1-60
	MCA	A.	30	35
	MOCP – Fuse Rating	A.	50	55
Operating Range	Cooling Outdoor DB Min – Max	°F(°C)	-4~122 (-20~50)	-4~122 (-20~50)
	Heating Outdoor DB Min – Max	°F(°C)	-4~86 (-20~30)	-4~86 (-20~30)
Piping	Total Piping Length	ft (m)	213 (65)	213 (65)
	Piping Lift*	ft (m)	98 (30)	98 (30)
	Pipe Connection Size – Liquid	in (mm)	3/8 (9.52)	3/8 (9.52)
	Pipe Connection Size – Suction	in (mm)	5/8 (16)	5/8 (16)
Refrigerant	Type		R410A	R410A
	Charge	lbs (kg)	7.5 (3.4)	9.48 (4.3)
	Metering Device		EEV	EEV
Outdoor Coil	Face Area	Sq. Ft.	8.2	14.1
	No. Rows		2.6	2
	Fins per inch		17	17
	Circuits		6	10
Compressor	Type		Rotary Inverter	Rotary Inverter
	Model		TNB306FPGMC-L	MNB36FAAMC-L
	Oil Type		FV50S	FV50S
	Oil Charge	Fl. Oz.	36.2	47.3
	Rated Current	RLA	13.5	13.5
Outdoor	Unit Width	in (mm)	37.20 (945)	36.93 (938)
	Unit Height	in (mm)	31.89 (810)	53.90 (1369)
	Unit Depth	in (mm)	15.55 (395)	15.43 (392)
	Net Weight	lbs (kg)	160.94 (73)	220 (100)
	Airflow	CFM	2,940	4,240
	Sound Pressure	dB(A)	65.0	65.0

\* Condensing unit above or below indoor unit

# DIMENSIONS

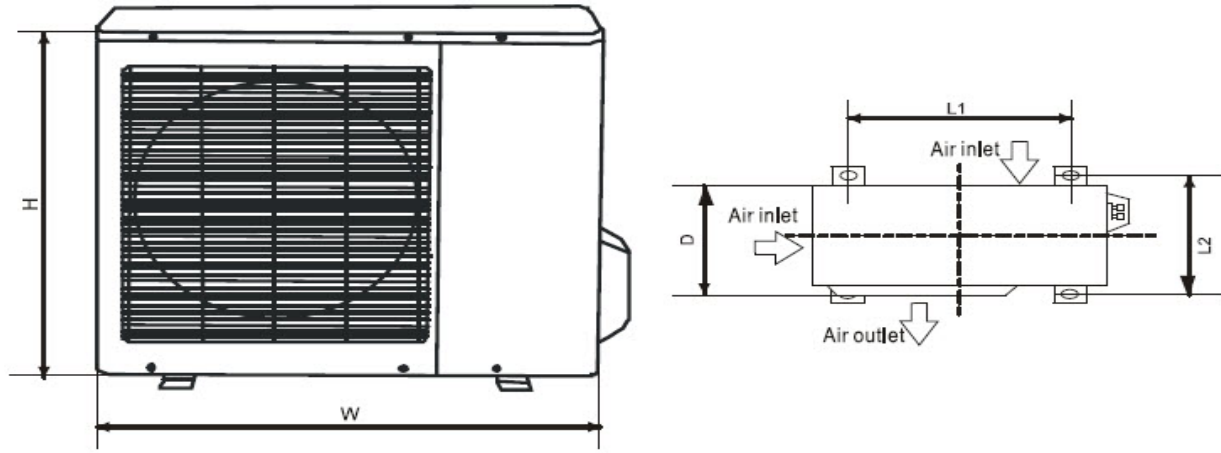

Fig. 1 – Outdoor Unit

Table 3—Outdoor Unit

UNIT SIZE	W in (mm)	D in (mm)	H in (mm)	L1 in (mm)	L2 in (mm)	OPERATING WEIGHT lb (kg)
36K	37.2 (945)	15.5 (395)	31.8 (810)	25.2 (640)	15.9 (405)	137.5 (62.4)
48K	36.93 (938)	15.4 (392)	53.9 (1369)	24.9 (634)	15.9 (404)	220 (100)

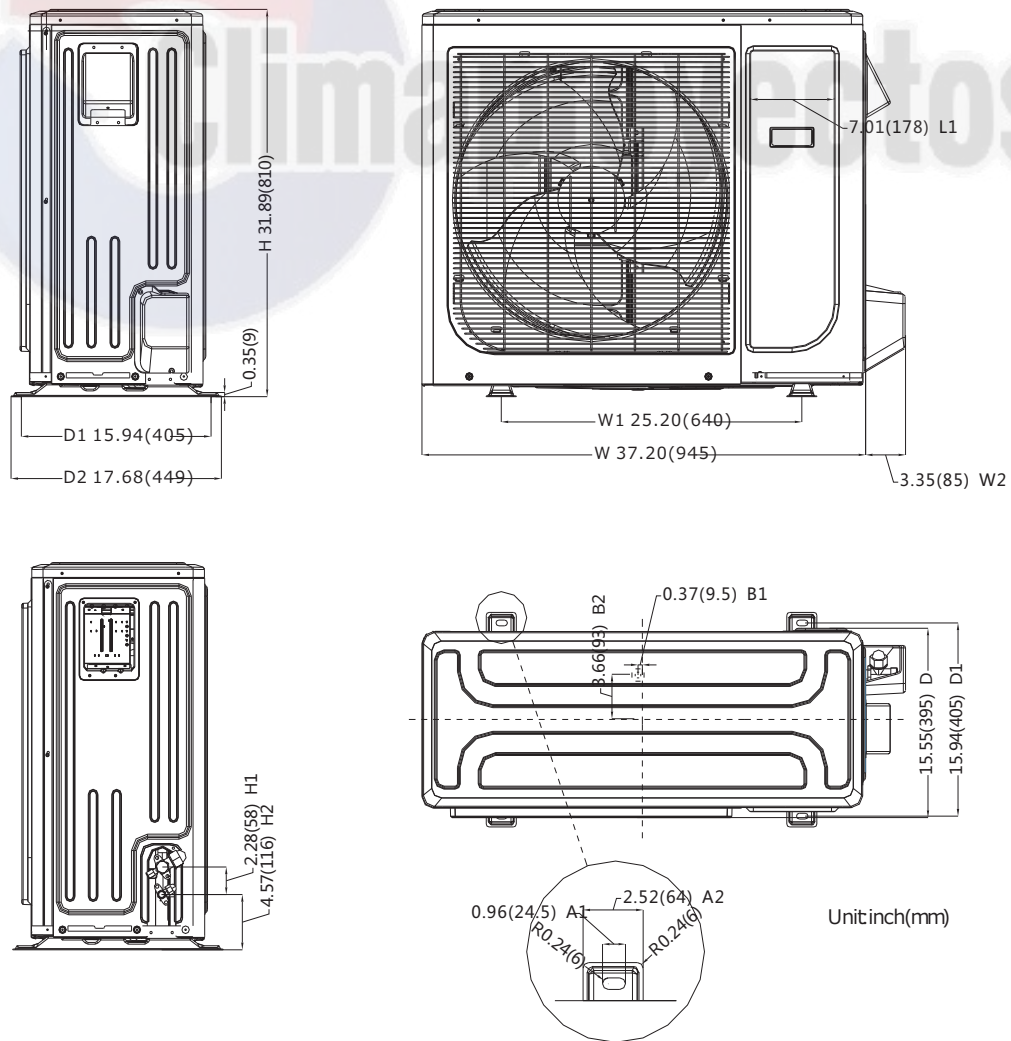
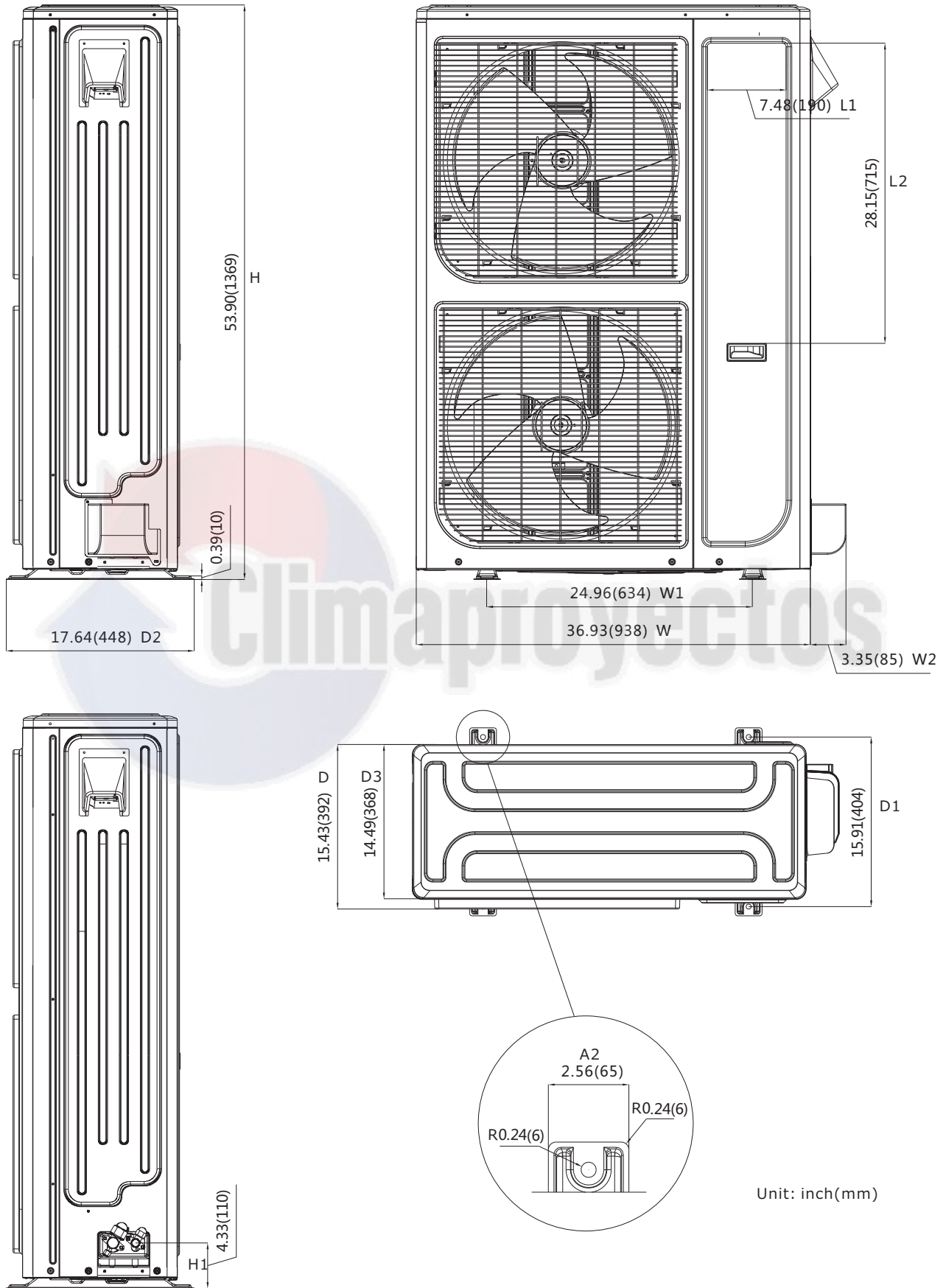

Fig. 2 – Sizes 36K

**DIMENSIONS – OUTDOOR (CONT)**



Unit: inch(mm)

**Fig. 3 – Sizes 48K**

## CLEARANCES – OUTDOOR

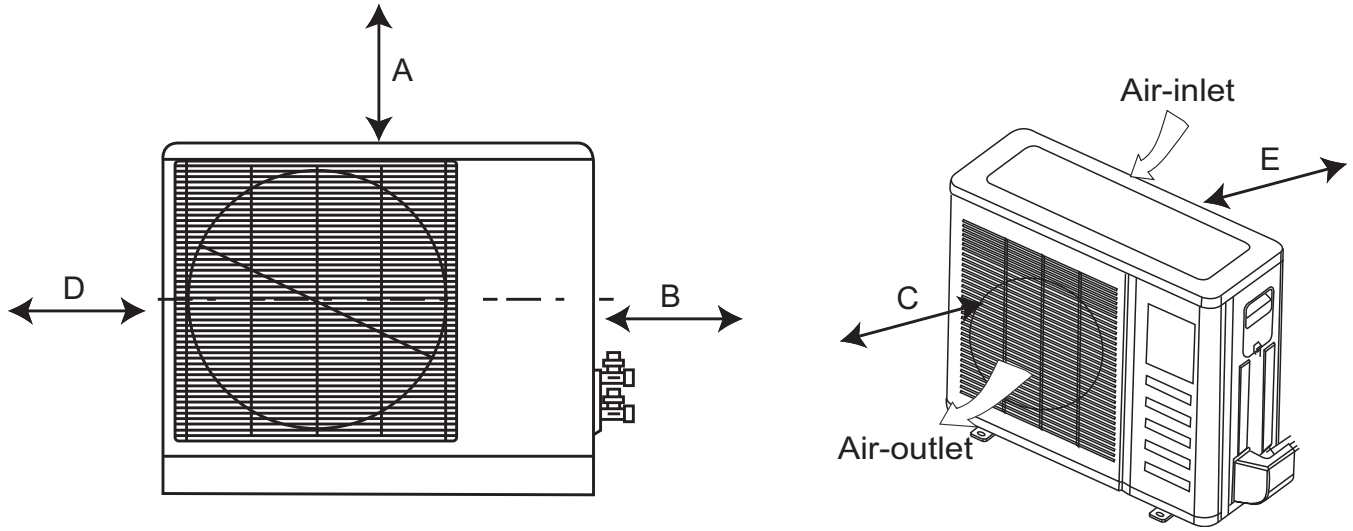

A07894

Fig. 4 – Outdoor Unit Clearance

Table 4—Outdoor Unit Clearance Dimensions

UNIT	MINIMUM VALUE in. (mm)
A	24 (610)
B	24 (610)
C	24 (610)
D	4 (101)
E	4 (101)

**NOTE:** Outdoor Unit must be mounted at least 2in (50mm) above the maximum anticipated snow depth.

# ELECTRICAL DATA

Table 5—Single Zone Outdoor Unit

OUTDOOR UNIT SIZE		36K	48K
Power Supply	Volts—PH—Hz	208/230—1—60	208/230—1—60
	Max – Min* Oper. Voltage	253—187	253—187
	MCA	30	35
	Max Fuse/CB AMP	50	55
Compressor	Volts—PH—Hz	208/230—1—60	208/230—1—60
	RLA	13.5	13.4

\*Permissible limits of the voltage range at which the unit will operate satisfactorily.

**LEGEND**

FLA - Full Load Amps  
MCA - Minimum Circuit Amps  
RLA - Rated Load Amps

## WIRING

All wires must be sized per NEC (National Electrical Code) or CEC (Canadian Electrical Code) and local codes. Use the Electrical Data table MCA (minimum circuit amps) and MOCP (maximum over current protection) to correctly size the wires and the disconnect fuse or breakers respectively.

Per the caution note, only stranded copper conductors with a 600 volt rating and double insulated copper wire must be used. The use of BX cable is not recommended.

**Recommended Connection Method for Power and Communication Wiring –**

**Power and Communication Wiring:**

The main power is supplied to the outdoor unit. The field supplied 14/3 power/communication wiring from the outdoor unit to the indoor unit consists of four (4) wires and provides the power for the indoor unit. Two wires are high voltage AC power, one is communication wiring and the other is a ground wire.

**Recommended Connection Method for Power and Communication Wiring (To minimize communication wiring interference)**

**Power Wiring:**

The main power is supplied to the outdoor unit. The field supplied power wiring from the outdoor unit to the indoor unit consists of three (3) wires and provides the power for the indoor unit. Two wires are high voltage AC power and one is a ground wire. To minimize voltage drop, the factory recommended wire size is 14/2 stranded with a ground.

**Communication Wiring:**

A separate shielded stranded copper conductor only, with a 600 volt rating and double insulated copper wire, must be used as the communication wire from the outdoor unit to the indoor unit. Please use a separate shielded 16GA stranded control wire.

## CONNECTION DIAGRAM

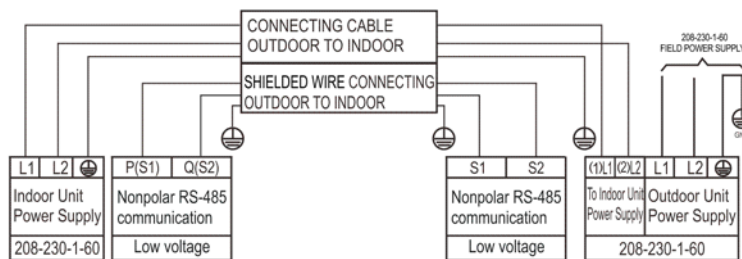

Fig. 5 – Connection Diagrams

A150688

**Notes:**

1. Do not use the thermostat wire for any connection between indoor and outdoor units.
2. All connections between indoor and outdoor units must be as shown. **The connections are sensitive to polarity and will result in a fault code.**



# WIRING DIAGRAMS

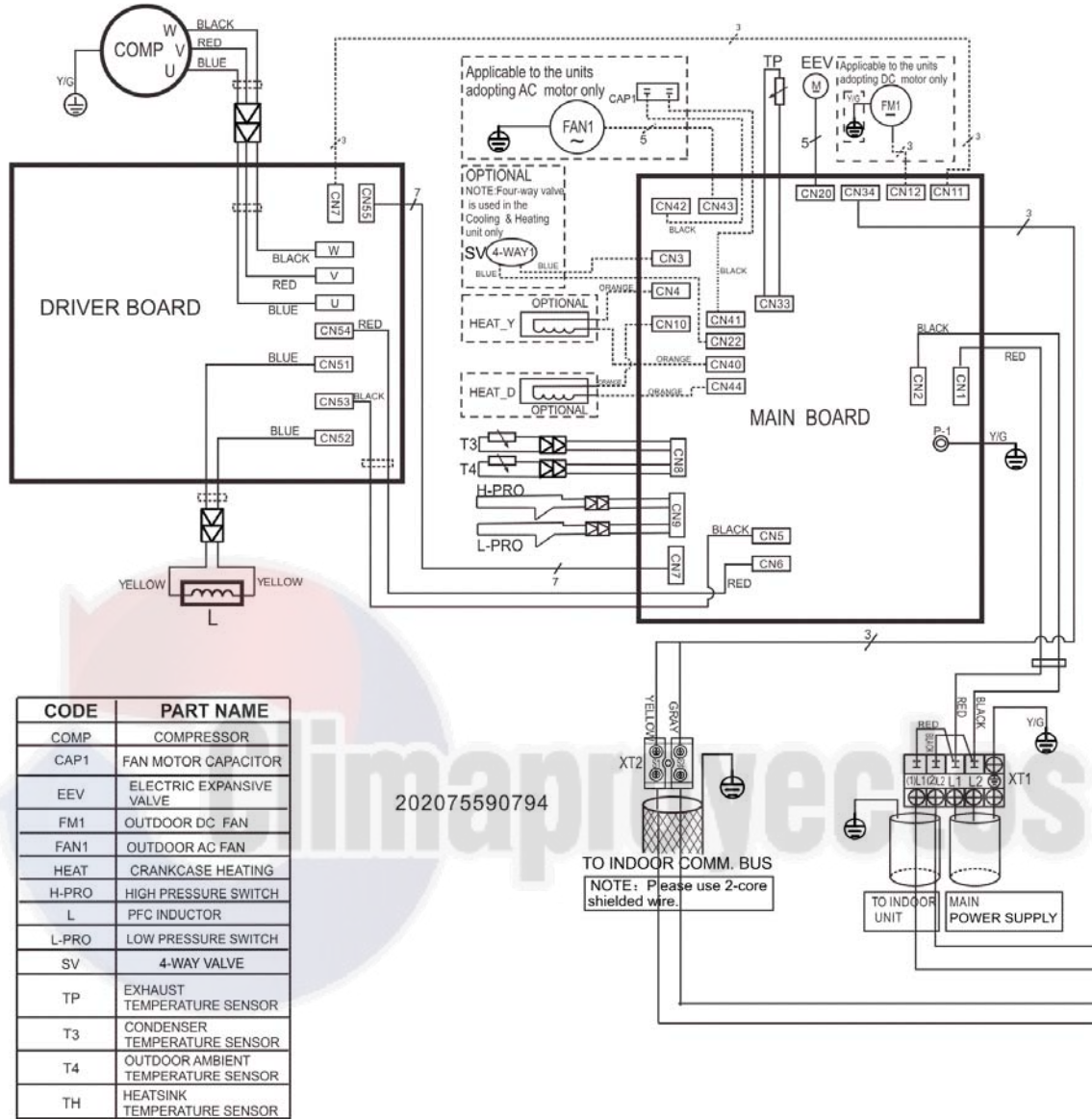

Fig. 6 – Wiring Diagram Size 36K

Table 6—Outdoor Unit Main Board

PART NAME	PART NAME
CN1,CN2	Power input: 230V AC
CN3,CN22	Output: High voltage for 4–way control (230V AC)
CN4,CN40	Output: High voltage for HEAT_Y control(230V AC)
CN5,CN6	Output: Power output to DRIVER BOARD (230V AC)
CN7	Input: Communication Main board and IPM Board,Pin1(12V DC),Pin2(5V DC )
CN8,CN33	Input: Temperature sensor (5V DC)
CN9	Input: Pressure test (5V DC)
CN10,CN44	Output: High voltage for HEAT_D control (230V AC)
CN11,CN12	Output: Pulse(0–380VDC) for DC FAN
CN20	Output: PMV control, Pin5(12V DC),Pin6(12V DC)
CN34	Communication to indoor unit,Pin1(5V DC),Pin3(5V DC)
CN41,CN42,CN43	Output: Power output for AC fan motor (230V AC)
P-1	Connection to the earth
<b>OUTDOOR UNIT (DRIVER BOARD)</b>	
PART NAME	PART NAME
U V W	Output: Pulse(0–380VDC) for COMPRESSOR
CN7	Output: Pulse(0–380VDC) for DC FAN
CN51,CN52	Output: Connect PFC Inductance, high DC Voltage
CN53,CN54	Input: Power input for DRIVER BOARD (230V AC)
CN55	Output: Communication IPM Board and Main board,Pin1(12V DC),Pin2(5V DC )



# WIRING DIAGRAMS (CONTINUED)

## WIRING DIAGRAM (OUTDOOR UNIT)

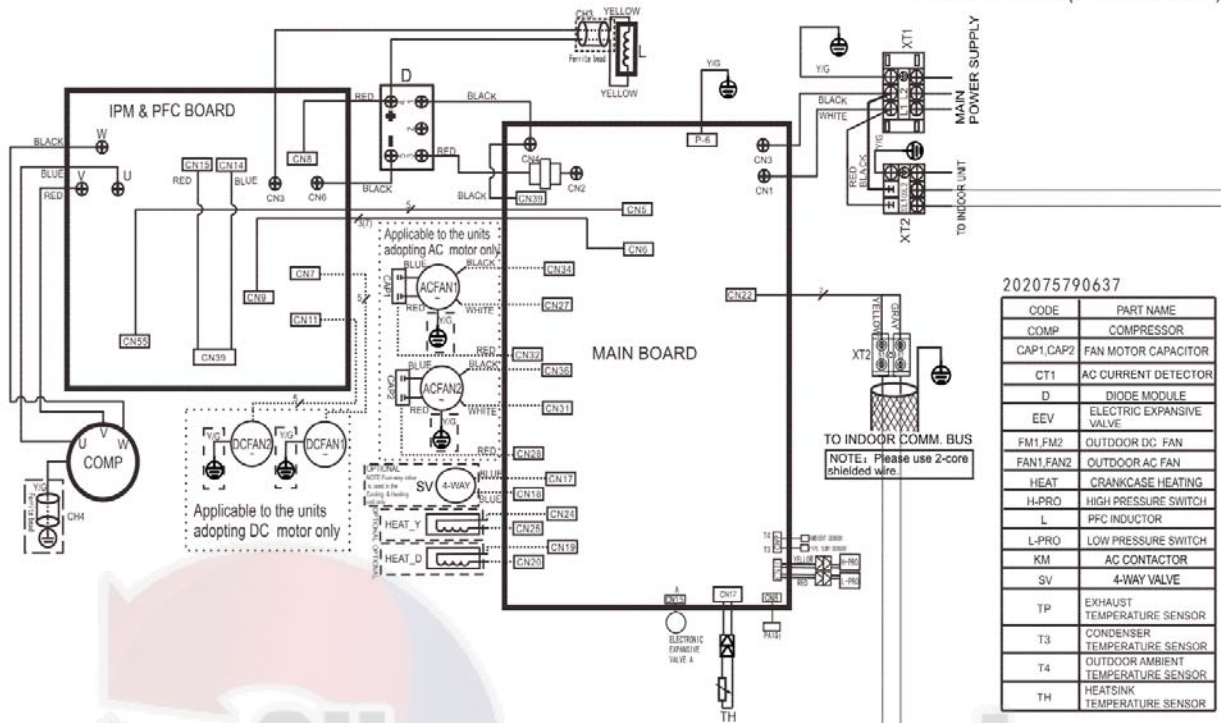

Fig. 7 – Wiring Diagram – Size 48K

Table 7—Outdoor Unit Main Board

CN1,CN3	Power input: 230V AC
CN2,CN4	Output: Power output for DRIVER BOARD (230V AC)
CN5	Input: Communication Main board and IPM Board, Pin1 (5V DC )
CN6	Input: DC FAN motor1 and DC FAN motor2 control, (Pin7 5V DC)
CN8,CN9,CN12	Input: Temperature sensor (5V DC)
CN10	Input: Pressure test (5V DC)
CN15	Output: PMV control, Pin5 (12V DC),Pin6 (12V DC)
CN17,CN18	Output: High voltage for 4–way (SV) control (230V AC)
CN19,CN20	Output: High voltage for HEAT_D control (230V AC)
CN22	Communication to indoor unit,Pin1 (5V DC),Pin3(5V DC)
CN24,CN25	Output: High voltage for HEAT_Y control (230V AC)
CN27、CN32、CN34、CN28、CN31、CN36	Output: Power output for AC FAN motor1 and AC FAN motor2 (230V AC)
CN39	Output: L2 for AC FAN、SV and HEAT, High voltage (AC)
P–6	Connection to the earth
<b>OUTDOOR UNIT (DRIVER BOARD)</b>	
U V W	Output: Pulse (0–380VDC) for COMPRESSOR
CN6 ,CN8	Input: Power input for DRIVER BOARD (200–320V DC )
CN3	Output: Connect PFC Inductance, high DC voltage
CN7,CN11	Output: DC FAN motor1 and DC FAN motor2 control (Pin1 310V or 380V DC)
CN9	Output: Communication Main board and IPM Board Pin7 (5V DC )
CN55	Output: Communication IPM Board and Main board Pin1 (12V DC )
CN14、CN15 — CN39,	Output: High DC voltage (310V or 380V DC)

# FAN AND MOTOR SPECIFICATIONS

Table 8—Fan and Motor Specifications

SYSTEM SIZE		36	48	
Outdoor Fan	Material	AS	AS	
	Type	ZL-560*139*12-3KN	ZL-525*135*12-3KFN	
	Diameter	inch	560	
	Height	inch	139	
Outdoor Fan Motor	Model	WZDK120-38G-W	WZDK85-38G	
	Phase	DC	DC	
	FLA	3	3	
	Type	1.21	0.33	
	Insulation Class		E	E
	Safe Class		IPX0	IPX0
	Input	W	150	98
	Output	W	120	85
	Range of Current	Amps	1.21±10%	0.33±10%
	Rated Current	Amps	1.21	0.33
	Rated HP	HP	0.16	0.11
	Speed	rev/min	950/850/750	950/850/750
	Rated RPM	rev/min	1050	850
	Max. Input	W	150	98



# REFRIGERATION CYCLE DIAGRAMS

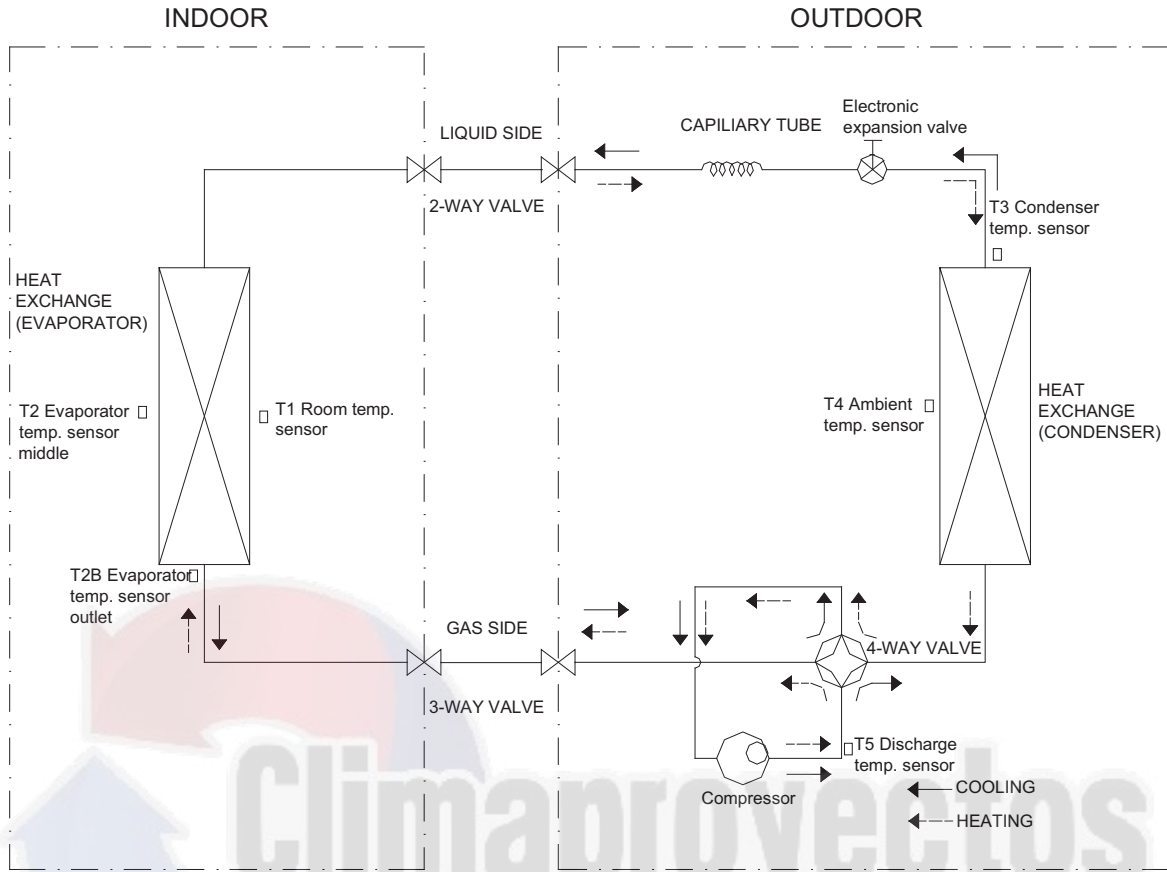

**Fig. 8 – Refrigerant Cycle Diagrams**

# REFRIGERANT LINES

## General refrigerant line sizing:

- 1 The outdoor units are shipped with a full charge of R410A refrigerant. All charges, line sizing, and capacities are based on runs of 25 ft. (7.6 m) per number of zones. For runs over 25 ft. (7.6 m), consult long-line section on this page for proper charge adjustments.
- 2 Minimum refrigerant line length between the indoor and outdoor units is 10 ft. (3 m).

- 3 Refrigerant lines should not be buried in the ground. If it is necessary to bury the lines, not more than 36-in (914 mm) should be buried. Provide a minimum 6-in (152 mm) vertical rise to the service valves to prevent refrigerant migration.
- 4 Both lines must be insulated. Use a minimum of 1/2-in. (12.7 mm) thick insulation. Closed-cell insulation is recommended in all long-line applications.
- 5 Special consideration should be given to isolating interconnecting tubing from the building structure. Isolate the tubing so that vibration or noise is not transmitted into the structure.

### IMPORTANT: Both refrigerant lines must be insulated separately.

- Table 9 provides the maximum lengths allowed.

**Table 9—Piping and Refrigerant**

SYSTEM SIZE			36K	48K
PIPING	Min. Piping Length	ft(m)	10(3)	10(3)
	Standard Piping Length	ft(m)	25(7.5)	25(7.5)
	Max. outdoor–indoor height difference (OU higher than IU)	ft(m)	98(30)	98(30)
	Max. outdoor–indoor height difference (IU higher than OU)	ft(m)	98(30)	98(30)
	Max. Piping length with no additional refrigerant charge	ft(m)	26(8)	26(8)
	Max. Piping Length	ft(m)	213(65)	213(65)
	Additional refrigerant charge (between Standard – Max piping length)	Oz/ft(g/m)	0.43(40)	0.43(40)
	Gas Pipe (size–connection type)	in(mm)	5/8(16)	5/8(16)
	Liquid Pipe (size–connection type)	in(mm)	3/8(9.52)	3/8(9.52)
REFRIGERANT	Refrigerant Type	--	R410A	R410A
	Charge Amount	Lbs(kg)	7.5(3.4)	9.48(4.3)

### Long Line Applications.:

- 1 No change in line sizing is required.
- 2 Add refrigerant per Table 10.

**Table 10—Additional Charge Table Per Zone**

UNIT SIZE	TOTAL LINE LENGHT ft		ADDITIONAL CHARGE, oz/ft. Ft (m)	
	Min	Max	> 10–25 (3–8)	> 25–213 (8–65)
36	10	213	None	0.43
48				

# SYSTEM EVACUATION AND CHARGING

⚠ **CAUTION**

**UNIT DAMAGE HAZARD**

Failure to follow this caution may result in equipment damage or improper operation.

Never use the system compressor as a vacuum pump.

Refrigerant tubes and indoor coil should be evacuated using the recommended deep vacuum method of 500 microns. The alternate triple evacuation method may be used if the following procedure is followed.

**NOTE: Always break a vacuum with dry nitrogen.**

## SYSTEM VACUUM AND CHARGE

### Using Vacuum Pump

- 1 Completely tighten the flare nuts (A, B, C, D, E). Fully open all circuits service valves. Connect the manifold gage charge hose to the charge port of the low side Master service valve to evacuate all circuits at the same time (see Fig. 9).
- 2 Connect charge hose to vacuum pump.
- 3 Fully open the low side of manifold gage (see Fig. 10).
- 4 Start the vacuum pump.
- 5 Evacuate using either the deep vacuum or triple evacuation method.
- 6 After evacuation is complete, fully close the low side of manifold gage and stop operation of vacuum pump.
- 7 The factory charge contained in the outdoor unit is good for up to 25ft. (8 m) of line length. For refrigerant lines longer than 25ft. (8 m), add refrigerant as specified in the *ADDITIONAL REFRIGERANT CHARGE* table in this document.
- 8 Disconnect the charge hose from the charge connection of the low side service valve.
- 9 Securely tighten caps of service valves.

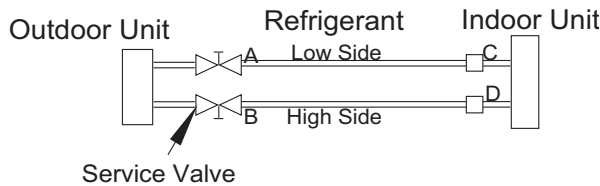

**Fig. 9 – Service Valve**

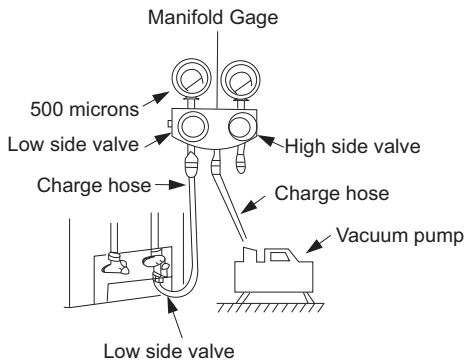

**Fig. 10 – Manifold**

### Deep Vacuum Method

The deep vacuum method requires a vacuum pump capable of pulling a vacuum of 500 microns and a vacuum gage capable of accurately measuring this vacuum depth. The deep vacuum method is the most positive way of assuring a system is free of air and liquid water (see Fig. 11).

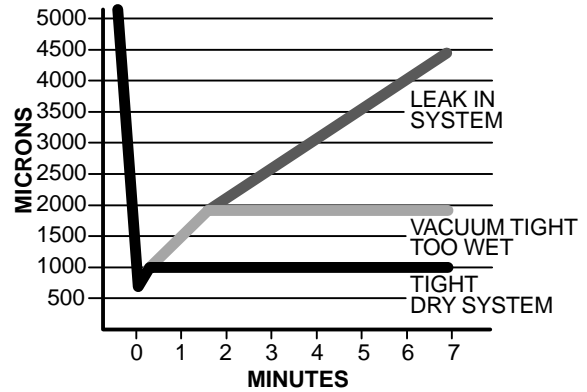
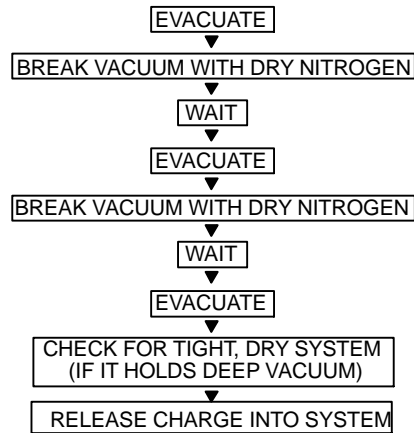

**Fig. 11 – Deep Vacuum Graph**

### Triple Evacuation Method

The triple evacuation method should be used. Refer to Fig. 12 and proceed as follows:

- 1 Pump system down to 500 MICRONS of mercury and allow pump to continue operating for an additional 15 minutes. Unit must maintain 500 microns or less for 30 minutes or more to ensure a dry system.
- 2 Close service valves and shut off vacuum pump.
- 3 Connect a nitrogen cylinder and regulator to system and open until system pressure is 2 psig.
- 4 Close service valve and allow system to stand for 10 minutes. During this time, dry nitrogen will be able to diffuse throughout the system absorbing moisture.
- 5 Repeat this procedure as indicated in Fig. 12. System will then be free of any contaminants and water vapor.



**Fig. 12 – Triple Evacuation Method**

### Final Tubing Check

**IMPORTANT:** Check to be certain factory tubing on both indoor and outdoor unit has not shifted during shipment. Ensure tubes are not rubbing against each other or any sheet metal. Pay close attention to feeder tubes, making sure wire ties on feeder tubes are secure and tight.

## SYSTEM OPERATING CONDITIONS

Table 11—System Operating Conditions

OPERATING RANGE MIN / MAX °F (°C)		
	COOLING	HEATING
Outdoor DB	-4/122 (-20/50)	-4/86 (-20/30)

### NOTE:

- If the air conditioner is used beyond the above conditions, certain safety protection features may engage and cause the unit to operate abnormally.

## ELECTRONIC FUNCTIONS

### Main Protection

#### Three Minute Delay for Compressor Restart

Less than a 1 minute delay for the initial start-up and a 3 minute delay for subsequent starts.

#### Compressor Top Temperature Protection

The unit stops working when the compressor top temp. protector cuts off, and restarts after the compressor top temp. protector restarts.

#### Compressor Discharge Temperature Protection

When the compressor discharge temp. increases, the running frequency is limited per the following rules:

- Compressor discharge temp.  $T_5 > 239^\circ\text{F}$  ( $115^\circ\text{C}$ ) for 5s, compressor stops and restarts up until  $T_5 < 194^\circ\text{F}$  ( $90^\circ\text{C}$ )
- $110 < T_5 < 239^\circ\text{F}$  ( $115^\circ\text{C}$ ), decrease the frequency to the lower level every 2 minutes.
- $221^\circ\text{F}$  ( $105^\circ\text{C}$ )  $< T_5 < 230^\circ\text{F}$  ( $110^\circ\text{C}$ ), keep running at the current frequency.
- $T_5 < 221^\circ\text{F}$  ( $105^\circ\text{C}$ ), no limit for frequency.

#### Fan Speed is Out of Control

When the indoor fan speed remains low (lower than 300RPM) for 50s, the indoor fan shuts off and restarts 30s later. If the protection mode engages 3 times when the fan motor restarts continuously, the unit stops and the LED displays the failure.

When the outdoor fan speed remains low (lower than 100RPM) or too high (higher than 1500RPM) for 60s, the unit stops and the LED displays the failure. The malfunction clears 30s later.

#### Inverter Module Protection

The inverter module has a protection function for current, voltage and temperature. If any of these protections engage, the corresponding code displays on the indoor unit and the unit stops working.

#### Indoor Fan Delayed Open Function

When the unit starts up, the louver is active immediately and the indoor fan opens 10s later. If the unit is running in the **HEATING** mode, the indoor fan is controlled also by the anti-cold wind function.

#### Compressor Preheating Functions

##### Preheating Permitting Condition:

If  $T_4 < 37.4^\circ\text{F}$  ( $3^\circ\text{C}$ ) and the machine connects to power supply newly within 5 seconds or if  $T_4 < 37.4^\circ\text{F}$  ( $3^\circ\text{C}$ ) and the compressor has stopped for over 3 hours, the compressor heating cable will work.

##### Preheating Mode:

A weak current flow through the compressor coil from the compressor wiring terminal, then the compressor is heated without operation.

##### Preheating Release Condition:

If  $T_4 \geq 41^\circ\text{F}$  ( $5^\circ\text{C}$ ) or the compressor starts running, the preheating function stops.

### Condenser High Temperature T3 Protection:

- $131^\circ\text{F}$  ( $55^\circ\text{C}$ )  $< T_3 < 140^\circ\text{F}$  ( $60^\circ\text{C}$ ), the compressor frequency decreases to the lower level until to F1 and then runs at F1. If  $T_3 < 129.2^\circ\text{F}$  ( $54^\circ\text{C}$ ), the compressor keeps running at the current frequency.
- $T_3 < 125.6^\circ\text{F}$  ( $52^\circ\text{C}$ ), the compressor does not limit the frequency and resumes the former frequency.
- $T_3 > 140^\circ\text{F}$  ( $60^\circ\text{C}$ ) for 5 seconds, the compressor stops until  $T_3 < 125.6^\circ\text{F}$  ( $52^\circ\text{C}$ ).

### Evaporator Low Temperature T2 Protection:

- $T_2 < 32^\circ\text{F}$  ( $0^\circ\text{C}$ ), the compressor stops and restarts when  $T_2 \geq 41^\circ\text{F}$  ( $5^\circ\text{C}$ ).
- $32^\circ\text{F}$  ( $0^\circ\text{C}$ )  $\leq T_2 < 39.2^\circ\text{F}$  ( $4^\circ\text{C}$ ), the compressor frequency is limited and decreases to the lower level
- $39.2^\circ\text{F}$  ( $4^\circ\text{C}$ )  $\leq T_2 < 44.6^\circ\text{F}$  ( $7^\circ\text{C}$ ), the compressor retains the current frequency
- $T_2 > 44.6^\circ\text{F}$  ( $7^\circ\text{C}$ ), the compressor frequency is not limited.

## Operation Modes and Functions

### Fan Mode

- Outdoor fan and compressor stop.
- Temperature setting function is disabled and no setting temperature is displayed.
- Indoor fan can be set to high/med/low/auto.
- The louver operates the same as in **COOLING** mode.
- Auto fan

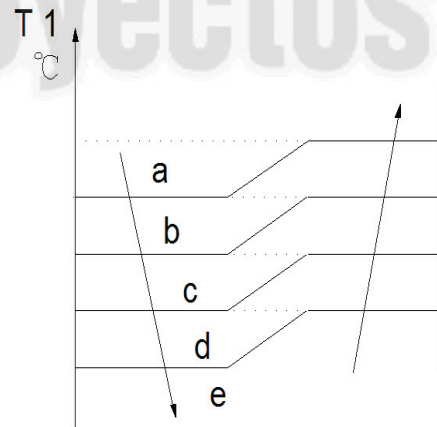

Fig. 13 – Fan Mode

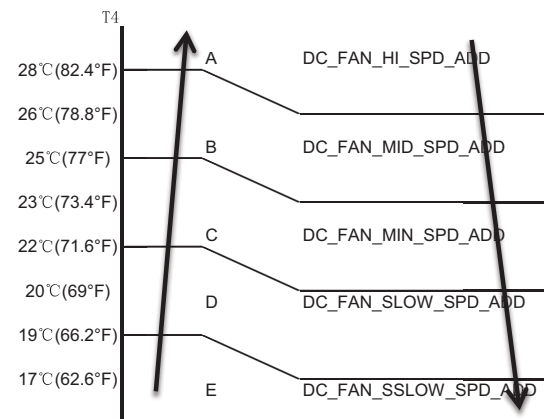

Fig. 14 – Outdoor Fan Running Rules



### Defrosting Mode

If any one of the following conditions are met, the AC enters the **DEFROSTING** mode. After the compressor starts and continues to run, mark the minimum value of T3 from the 10th minute to 15th minute as T30.

- If the compressor cumulate running time is up to 29 minutes and  $T3 < TCDI1$ ,  $T3 + T30SUBT3ONE \leq T30$ .
- If the compressor cumulate running time is up to 35 minutes and  $T3 < TCDI2$ ,  $T3 + T30SUBT3TWO \leq T30$ .
- If the compressor cumulate running time is up to 29 minutes and  $T3 < TCDI3$  for 3 minutes.
- If the compressor cumulate running time is up to 120 minutes and  $T3 < 5^\circ F (-15^\circ C)$ .

### Condition of Ending Defrosting:

If any one of the following items is satisfied, the **DEFROSTING** mode completes and the machine enters the normal **HEATING** mode.

- T3 rises to be higher than TCDE1.
- T3 keeps to be higher than TCDE2 for 80 seconds.

### Defrosting Action:

—The machine has run for 10 minutes in **DEFROSTING** mode.

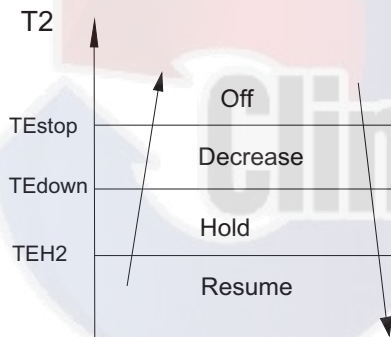

Fig. 15 – Defrosting Action

### Point Check Function

Press the remote controller LED DISPLAY or LED or MUTE button three times, and then press the AIR DIRECTION or SWING button three times in ten seconds (the buzzer rings for two seconds). The air conditioner enters the information enquiry status.

The user can press the LED DISPLAY or AIR DIRECTION button to check the next or front item's information. When the air conditioner enters the enquiry information status, it displays the code name in 2 seconds. Refer to Table 12 for details.

Table 12—Enquiry Information

ENQUIRY INFO	DISPLAYING CODE	MEANING
T1	T1	T1 temp.
T2	T2	T2 temp.
T3	T3	T3 temp.
T4	T4	T4 temp.
T2B	Tb	T2B temp.
TP	TP	TP temp.
TH	TH	TH temp.
Targeted Frequency	FT	Targeted Frequency
Actual Frequency	Fr	Actual Frequency
Indoor Fan Speed	IF	Indoor Fan Speed
Outdoor Fan Speed	OF	Outdoor Fan Speed
EXV Opening Angle	LA	EXV Opening Angle
Compressor Continuous Running Time	CT	Compressor Continuous Running Time
Compressor Stop Issues	ST	Compressor Stop Issues

When the air conditioner enters the information enquiry status, the LED displays the code value within 25 seconds (see Table 13).

Table 13—Enquiry Information

ENQUIRY INFO	DISPLAY VALUE	MEANING	REMARK
T1, T2, T3, T4, T2B, TP, TH, Targeted Frequency, Actual Frequency	-1F, -1E, -1d, -1c, -1b, -1A	-25, -24, -23, -22, -21, -20	1. The displaying temperature is the actual value. 2. Temp. is °C no matter the remote. 3. T1, T2, T3, T4, T2B display range: -25~70. 4. Freq. display range: 0~159HZ. 5. If the actual value exceeds the range, it displays the maximum value or minimum value.
	-19-99	-19-99	
	A0, A1, 0A9	100, 101, 0109	
	b0, b1, 0b9	110, 111, 0119	
	c0, c1, 0c9	120, 121, 0129	
	d0, d1, 0d9	130, 131, 0139	
	E0, E1, 0E9	140, 141, 0149	
F0, F1, 0F9	150, 151, 0159		
Indoor Fan Speed/ Outdoor Fan Speed	0	OFF	For some big capacity motors.  For some small capacity motors, the display value is from 14-FF (hexadecimal), the corresponding fan speed range is from 200-2550 RPM.
	1, 2, 3, 4	Low speed, Medium speed, High speed, Turbo	
	14-FF	Actual fan speed = Display value turns to decimal value and then multiply 10. The unit is RPM.	
EXV Opening Angle	0-FF	Actual EXV opening value = Display value turns to decimal value and then multiply 2.	
Compressor Continuous Running Time	0-FF	0-255 minutes	If the actual value exceeds the range, it displays the maximum value or minimum value.
Compressor Stop Causes	0-99	For the detailed meaning, please consult with engineer	Decimal display

# TROUBLESHOOTING

This section provides the required flow charts to troubleshoot problems that may arise.

**NOTE: Information required in the diagnoses can be found either on the wiring diagrams or in the appendix.**

## Required Tools:

The following tools are needed when diagnosing the units:

- Digital multimeter
- Screw drivers (Phillips and straight head)
- Needle-nose pliers
- Refrigeration gauges

## Recommended Steps

- 1 Refer to the diagnostic hierarchy charts below and determine the problem at hand.
- 2 Go to the chart listed in the diagnostic hierarchy and follow the steps in the chart for the selected problem.

For the ease of service, the systems are equipped with diagnostic code display LED's on both the indoor and outdoor units. The outdoor diagnostic display is on the outdoor unit board and is limited to very few errors. The indoor diagnostic display is a combination of flashing LED's on the display panel on the front of the unit. If possible always check the diagnostic codes displayed on the indoor unit first.

The diagnostic codes for the indoor and outdoor units are listed in the appendix.

Problems may occur that are not covered by a diagnostic code, but are covered by the diagnostic flow charts. These problems are typical air conditioning mechanical or electrical issues that can be corrected using standard air conditioning repair techniques.

For problems requiring measurements at the control boards, note the following:

- 1 Always disconnect the main power.
- 2 When possible check the outdoor board first.
- 3 Start by removing the outdoor unit top cover.
- 4 Reconnect the main power
- 5 Probe the outdoor board inputs and outputs with a digital multi-meter referring to the wiring diagrams.
- 6 Connect the red probe to hot signal and the black probe to the ground or negative.
- 7 Note that some of the DC voltage signals are pulsating voltages for signal. this pulse should be rapidly moving at all times when there is a signal present.
- 8 If it is necessary to check the indoor unit board you must start by disconnecting the main power.
- 9 Next remove the front cover of the unit and then control box cover.
- 10 Carefully remove the indoor board from the control box, place it face up on a plastic surface (not metal).
- 11 Reconnect the main power and repeat steps 5, 6, and 7.
- 12 Disconnect main power before reinstalling board to avoid shock hazard and board damage.

# DIAGNOSTIC GUIDES

**Table 14—Diagnostic Guides Indoor Units**

OPERATION LAMP	TIMER LAMP	DISPLAY	LED STATUS
☆ 1 time	X	E0	Indoor unit EEPROM parameter error
☆ 2 times	X	E1	Communication malfunction between indoor and outdoor units
☆ 4 times	X	E3	Indoor fan speed malfunction
☆ 5 times	X	E4	Indoor room temperature sensor (T1 ) malfunction
☆ 6 times	X	E5	Evaporator coil temperature sensor (T2) malfunction
☆ 7 times	X	EC	Refrigerant leakage detection
☆ 8 times	X	EE	Water-level alarm malfunction
☆ 1 time	O	F0	Current overload protection
☆ 2 times	O	F1	Outdoor ambient temperature sensor (T4 ) malfunction
☆ 3 times	O	F2	Condenser coil temperature sensor (T3) malfunction
☆ 4 times	O	F3	Compressor discharge temperature sensor (T5) malfunction
☆ 5 times	O	F4	Outdoor unit EEPROM parameter error
☆ 6 times	O	F5	Outdoor fan speed malfunction
☆ 7 times	O	F6	Indoor coil outlet pipe sensor(Located on outdoor unit low pressure valve)
☆ 8 times	O	F7	Communication malfunction between the cassette optional lift panel and the unit
☆ 9 times	O	F8	Cassette optional lift panel malfunction
☆ 10 times	O	F9	Cassette optional lift panel not closed
☆ 1 time	☆	P0	Inverter module (IPM) malfunction
☆ 2 times	☆	P1	Over-voltage or under-voltage protection
☆ 3 times	☆	P2	Compressor top high temperature protection (OLP)
☆ 4 times	☆	P3	Low ambient temperature cut off in heating
☆ 5 times	☆	P4	Compressor drive malfunction
☆ 6 times	☆	P5	Indoor units mode conflict
☆ 7 times	☆	P6	Low pressure protection
☆ 8 times	☆	P7	Outdoor IPM temperature sensor error

**O (light)    X (off)    ☆ (flash)**

# DIAGNOSIS AND SOLUTION

## Outdoor Unit Error Display

Table 15—Diagnostic Table Outdoor Units

NO.	PROBLEMS	ERROR CODE
1	Communication malfunction between indoor and outdoor units	E1
2	Current overload protection	F0
3	Outdoor ambient temperature sensor (T4 ) malfunction	F1
4	Condenser coil temperature sensor (T3) malfunction	F2
5	Compressor discharge temperature sensor (T5) malfunction	F3
6	Outdoor unit EEPROM parameter error	F4
7	Outdoor fan speed malfunction	F5
8	Inverter module (IPM) malfunction	P0
9	Over-voltage or under-voltage protection	P1
10	Compressor top high temperature protection (OLP)	P2
11	Low ambient temperature cut off in heating	P3
12	Compressor drive malfunction	P4
13	High temperature protection of indoor coil in heating	J0
14	Outdoor temperature protection of outdoor coil in cooling	J1
15	Temperature protection of compressor discharge	J2
16	PFC module protection	J3
17	Communication malfunction between control board and IPM board	J4
18	High pressure protection	J5
19	Low pressure protection	J6
20	Outdoor IPM module temperature sensor malfunction	P7
21	AC voltage protection	J8

# DIAGNOSIS AND SOLUTION (CONT)

Table 16—Outdoor Check Function

N	DISPLAY	REMARK		
00	Normal display	Display running frequency, running state or malfunction code		
01	Indoor unit capacity demand code	Actual data*HP*10 If the capacity demand code is higher than 99, the digital display tube displays a single digit and tens digit. (For example, the digital display tube displays "5.0",it means the capacity demand is 15. The digital display tube show "60",it means the capacity demand is 6.0)		
02	Amendatory capacity demand code			
03	The frequency after the capacity requirement transfer			
04	The frequency after the frequency limit			
05	The frequency of sending to 341 chip			
06	Indoor unit evaporator outlet temp.(heating T2, cooling T2B)	If the temp. is lower than 0 degree, the digital display tube displays "0". If the temp. is higher than 70 degree, the digital display tube displays "70".		
07	Condenser pipe temp.(T3)	If the temp. is lower than -9 degree, the digital display tube displays "-9".If the temp. is higher than 70 degree, the digital display tube displays "70". If the indoor unit is not connected, the digital display tube displays: "--"		
08	Outdoor ambient temp.(T4)			
09	Compressor discharge temp.(T5)	The display value is between 13~129 degree. If the temp. is lower than 13 degree, the digital display tube displays "13". If the temp. is higher than 99 degree, the digital display tube displays a single digit and a tens digit. (For example, if the digital display tube displays "0.5",it means the compressor discharge temp. is 105 degree. If the digital display tube displays "1.6",it means the compressor discharge temp. is 116 degrees).		
10	AD value of current	The display value is a hex number.		
11	AD value of voltage			
12	Indoor unit running mode code			
13	Outdoor unit running mode code	Off:0, Fan only 1,Cooling:2, Heating:3 Off:0, Fan only 1,Cooling:2, Heating:3, Forced cooling:4		
14	EXV open angle	Actual data/4. If the value is higher than 99, the digital display tube displays a single digit and a tens digit. For example, if the digital display tube displays "2.0",it means the EXV open angle is 120×4=480p.)		
15	Frequency limit symbol	Bit7	Frequency limit caused by IGBT radiator	The display value is a hex number. For ex., the digital display tube displays 2A, then Bit5=1, Bit3=1, Bit1=1. It represents the frequency limit caused by T4, T3 and current.
		Bit6	Frequency limit caused by PFC	
		Bit5	Frequency limit caused by T4	
		Bit4	Frequency limit caused by T2	
		Bit3	Frequency limit caused by T3	
		Bit2	Frequency limit caused by T5	
		Bit1	Frequency limit caused by current	
Bit0	Frequency limit caused by voltage			
16	DC fan motor speed			
17	IGBT radiator temp.	The display value is between 30~120 degrees. If the temp. is lower than 30 degrees, the digital display tube displays "30".If the temp. is higher than 99 degrees, the digital display tube displays a single digit and a tens digit. (For example, if the digital display tube displays "0.5",it means the IGBT radiator temp. is 105 degrees. If the digital display tube displays "1.6", it means the IGBT radiator temp. is 116 degrees).		
18	Indoor unit number	The indoor unit can communicate well with the outdoor unit. General:1, Twins:2		
19	Evaporator pipe temp. T2 of 1# indoor unit	If the temp. is lower than 0 degree, the digital display tube displays "0".If the temp. is higher than 70 degrees, the digital display tube displays "70". If the indoor unit is not connected, the digital display tube displays: "--".		
20	Evaporator pipe temp. T2 of 2# indoor unit			
21	Evaporator pipe temp. T2 of 3# indoor unit			
22	1# Indoor unit capacity demand code	Actual data*HP*10		
23	2# Indoor unit capacity demand code	If the capacity demand code is higher than 99, the digital display tube displays a single digit and a tens digit. (For example, the digital display tube displays "5.0",it means the capacity demand is 15. If the digital display tube displays "60",it means the capacity demand is 6.0).		
24	3# Indoor unit capacity demand code	If the indoor unit is not connected, the digital display tube displays: "--".		
25	Room temp. T1 of 1# indoor unit	If the temp. is lower than 0 degree, the digital display tube displays "0".If the temp. is higher than 70 degrees, the digital display tube displays "70". If the indoor unit is not connected, the digital display tube displays: "--".		
26	Room temp. T1 of 2# indoor unit			
27	Average room temp. T1			
28	Reason of stop			
29	Evaporator pipe temp. T2B of 1# indoor unit	If the temp. is lower than 0 degree, the digital display tube displays "0".If the temp. is higher than 70 degrees, the digital display tube displays "70". If the indoor unit is not connected, the digital display tube displays: "--".		

## DIAGNOSIS AND SOLUTION (CONT)

Table 17—EEPROM Parameter Error Diagnosis and Solution (E0/F4)

Error Code	E0/F4
Malfunction conditions	Indoor or outdoor PCB main chip does not receive feedback from EEPROM chip.
Potential causes	<ul style="list-style-type: none"><li>• Installation mistake</li><li>• Faulty PCB</li></ul>

### Troubleshooting

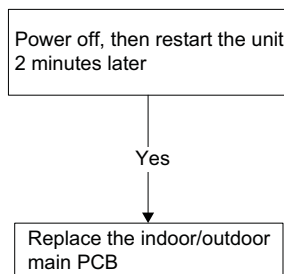

**EEPROM:** A read-only memory whose contents can be erased and reprogrammed using a pulsed voltage. For the location of EEPROM chip, refer to the following images.

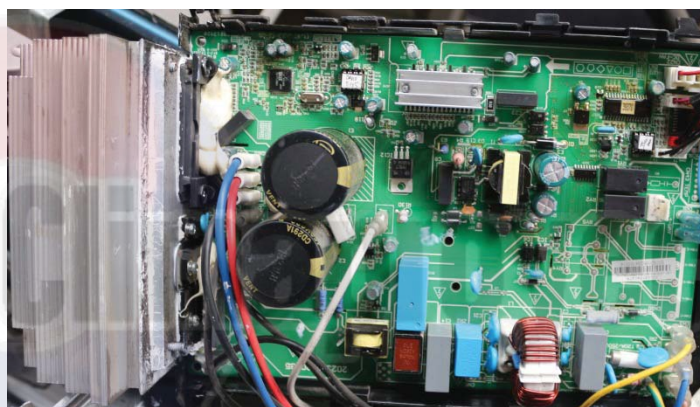

Fig. 16 – Outdoor PCB

**NOTE:** Fig. 16 is for illustration purposes only and may differ from your actual unit.



# DIAGNOSIS AND SOLUTION (CONT)

**Table 18—Overload Current Protection Diagnosis and Solution (F0)**

<b>Error Code</b>	<b>F0</b>
<b>Malfunction decision conditions</b>	An abnormal current rise is detected by checking the specified current detection circuit.
<b>Supposed causes</b>	<ul style="list-style-type: none"> <li>• Power supply problems</li> <li>• System blockage</li> <li>• PCB faulty</li> <li>• Wiring mistake</li> <li>• Compressor malfunction</li> </ul>

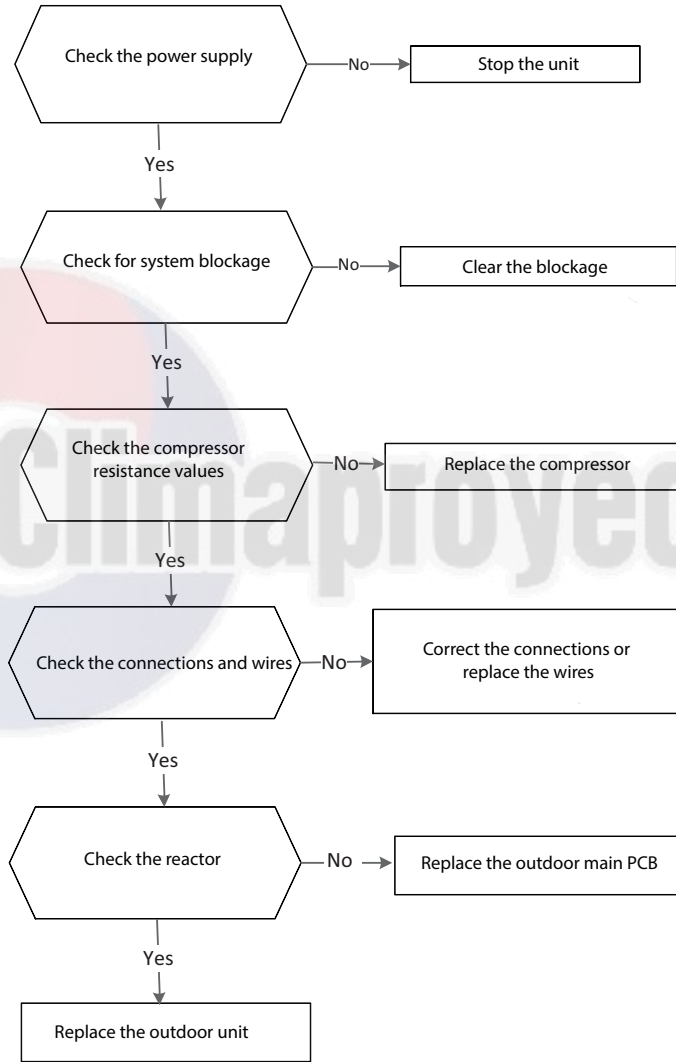

# DIAGNOSIS AND SOLUTION (CONT)

Table 19—Indoor/Outdoor Unit Communication Error – Diagnosis and Solution (E1)

<b>Error Code</b>	<b>E1</b>
<b>Malfunction decision conditions</b>	Indoor unit does not receive feedback from outdoor unit for 60 seconds, or the outdoor unit does not receive feedback from indoor unit for 120 seconds.
<b>Supposed causes</b>	<ul style="list-style-type: none"> <li>• Wiring mistakes</li> <li>• Faulty indoor or outdoor PCB</li> </ul>

**Troubleshooting:**

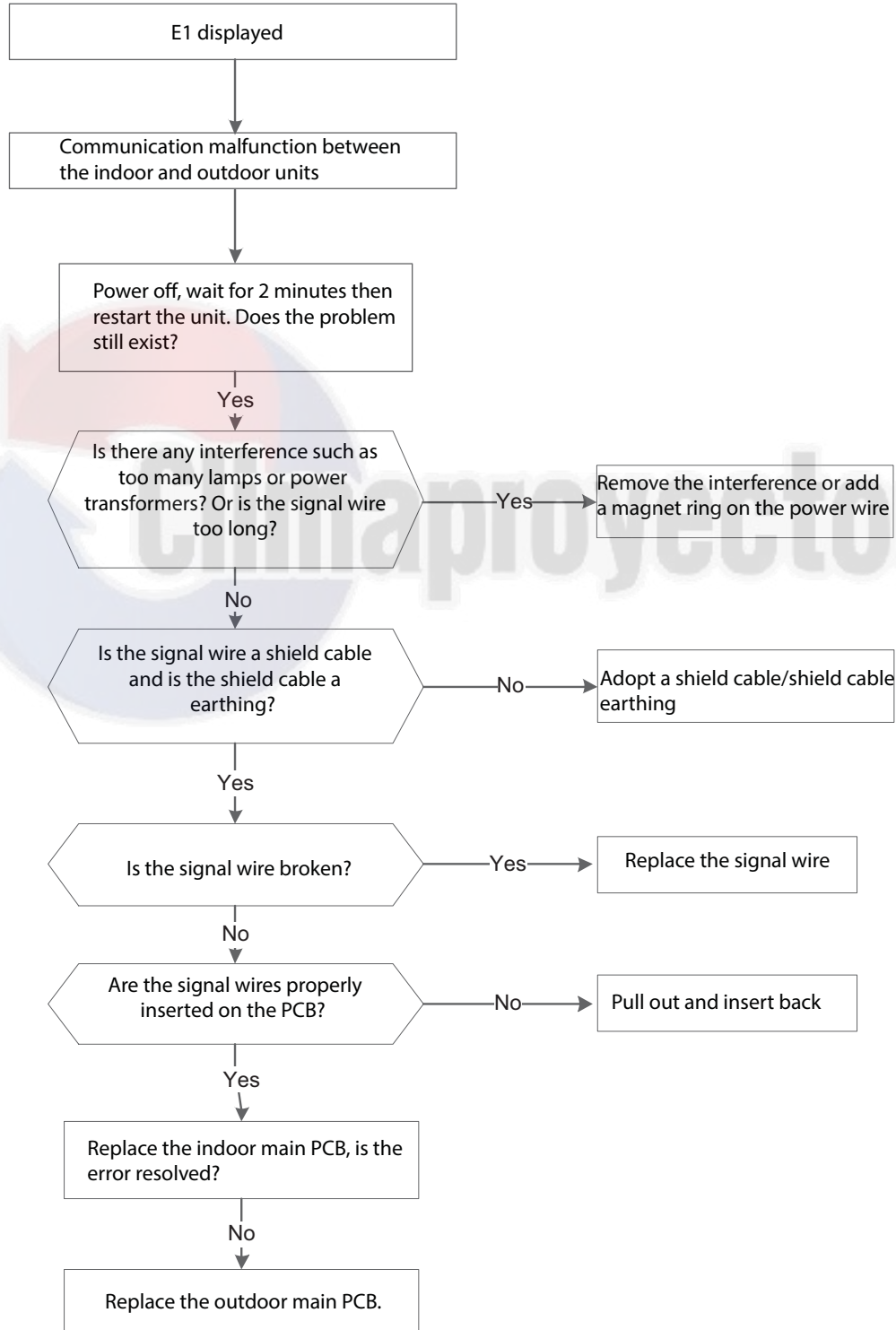

## DIAGNOSIS AND SOLUTION (CONT)

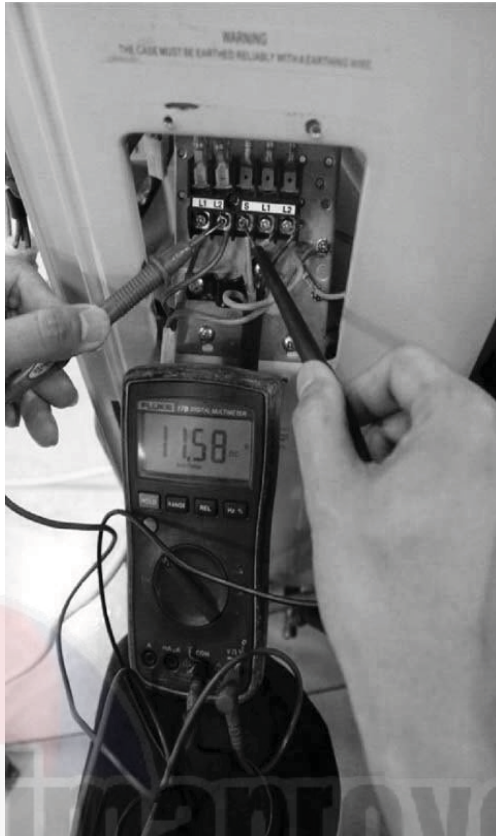

Fig. 17 – DC Voltage Test

### **Remark**

Use a multimeter to test the DC voltage between the outdoor unit's L2 port and S ports (Fig. 16). The red pin of the multimeter connects with the L2 port while the black pin is for the S port. When the AC is running normally, the voltage moves alternatively between  $-50\text{V}$  to  $50\text{V}$ .

If the outdoor unit has a malfunction, the voltage moves alternatively with a positive value. If the indoor unit has a malfunction, the voltage has a certain value. Example:  $10\text{--}13\text{VDC}$  small fluctuating amounts indicates indoor unit malfunction.

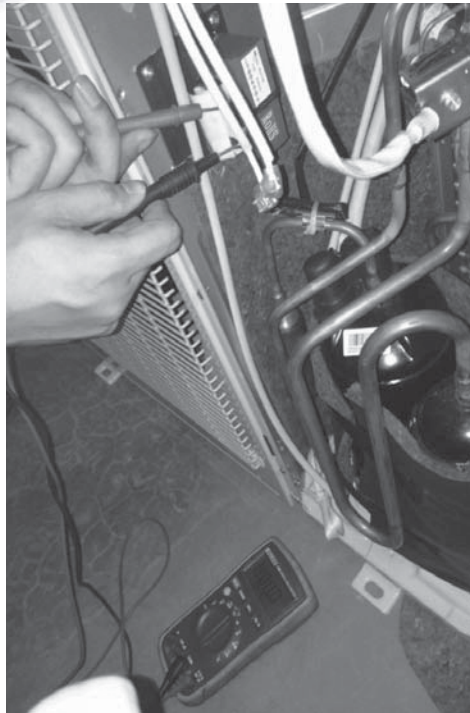

Fig. 18 – Reactor Resistance Test

### **Remark**

Use a multimeter to test the reactor resistance that does not connect with the capacitor (Fig. 18). The normal values should be around zero ohm. Otherwise, the reactor has malfunctioned and needs to be replaced.

## DIAGNOSIS AND SOLUTION (CONT)

### Index 1

Indoor or Outdoor DC Fan Motor (control chip is in the fan motor). Power on and when the unit is in standby, measure the voltage of pin-1 – pin3, pin4 –pin3 in the fan motor connector. If the value of the voltage is not in the range showing in the table below, the PCB has an issue and needs to be replaced.

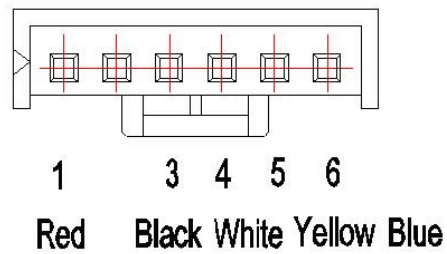

Fig. 19 – Control Chip

Table 20—DC motor voltage input and output

No.	COLOR	SIGNAL	VOLTAGE
1	Red	Vs/Vm	200~380V
2	---	---	---
3	Black	GND	0V
4	White	Vcc	13.5~16.5V
5	Yellow	Vsp	0~6.5V
6	Blue	FG	13.5~16.5V



# DIAGNOSIS AND SOLUTION (CONT)

Table 21—Open Circuit or Short Circuit of Temperature Sensor Diagnosis and Solution (E4/E5/F1/F2/F3)

<b>Error Code</b>	<b>E4/E5/F1/F2/F3</b>
<b>Malfunction Decision Conditions</b>	If the sampling voltage is lower than 0.06V or higher than 4.94V, the LED displays the failure.
<b>Supposed Causes</b>	<ul style="list-style-type: none"> <li>• Wiring mistake</li> <li>• Sensor Faulty</li> </ul>

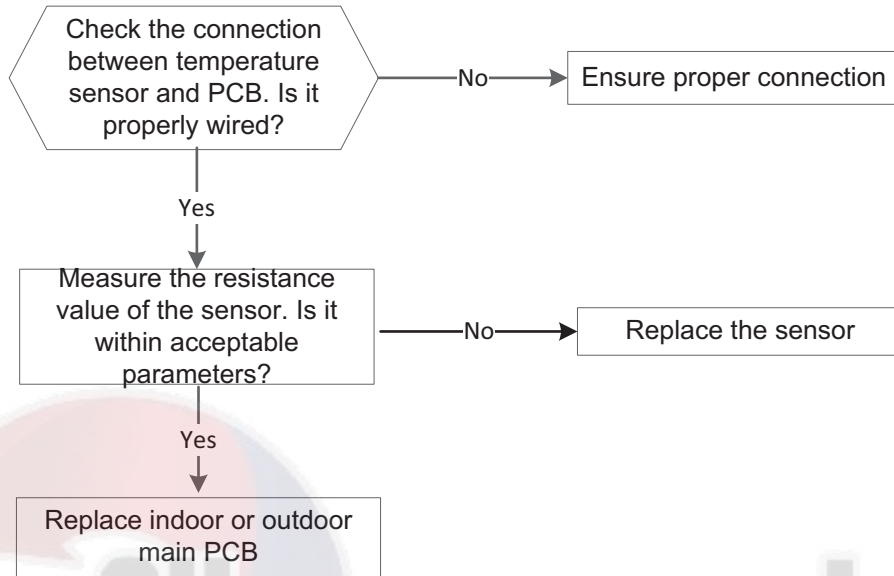

Fig. 20 – Test

# DIAGNOSIS AND SOLUTION (CONT)

Table 22—Refrigerant Leakage Detection Diagnosis and Solution (EC)

<b>Error Code</b>	<b>EC</b>
<b>Malfunction Decision Conditions</b>	Define the evaporator coil temp.T2 of the compressor just starts running as Tcool. In the beginning 5 minutes after the compressor starts up, if $T2 < T_{cool} - 35.6^{\circ}\text{F} (T_{cool} - 2^{\circ}\text{C})$ does not keep continuous 4 seconds and this situation happens 3 times, the display area shows "EC" and AC turns off.
<b>Supposed Causes</b>	<ul style="list-style-type: none"> <li>• T2 sensor faulty</li> <li>• Indoor PCB faulty</li> <li>• System problems, such as leakage or blocking</li> </ul>

**Troubleshooting:**

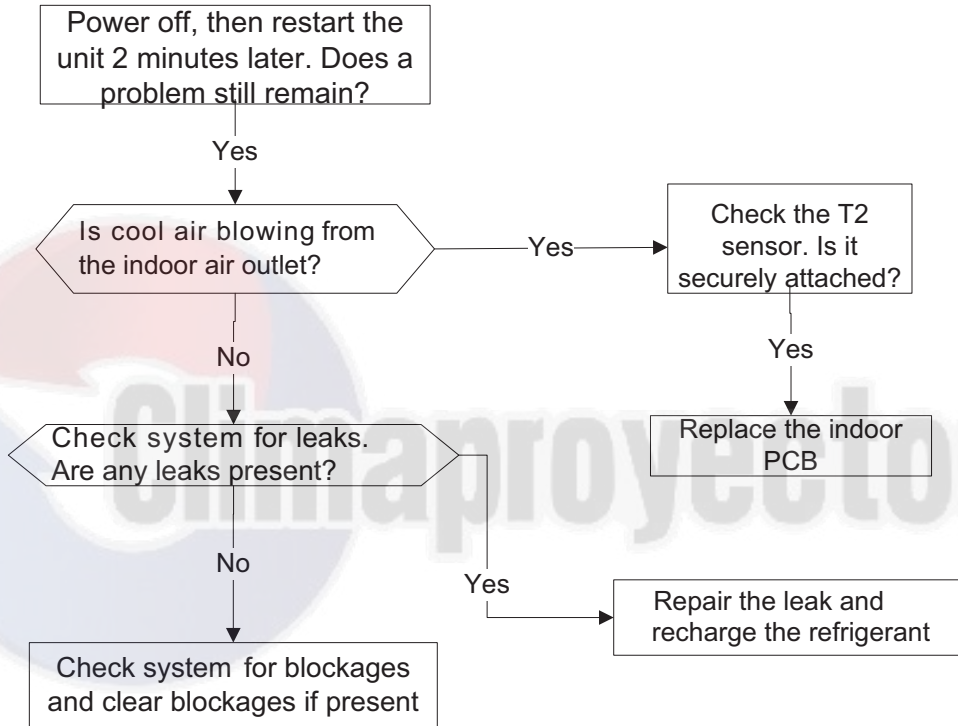



# DIAGNOSIS AND SOLUTION (CONT)

Table 23—IPM Malfunction or IGBT Over–strong Current Protection Diagnosis and Solution (PO)

Error Code	PO
<b>Malfunction Decision Conditions</b>	When the voltage signal that IPM sends to the compressor drive chip is abnormal, the LED displays “PO” and the AC turns off.
<b>Supposed Causes</b>	<ul style="list-style-type: none"> <li>• Wiring mistake</li> <li>• IPM malfunction</li> <li>• Outdoor fan assembly faulty</li> <li>• Compressor malfunction</li> <li>• Outdoor PCB faulty</li> </ul>

## Troubleshooting

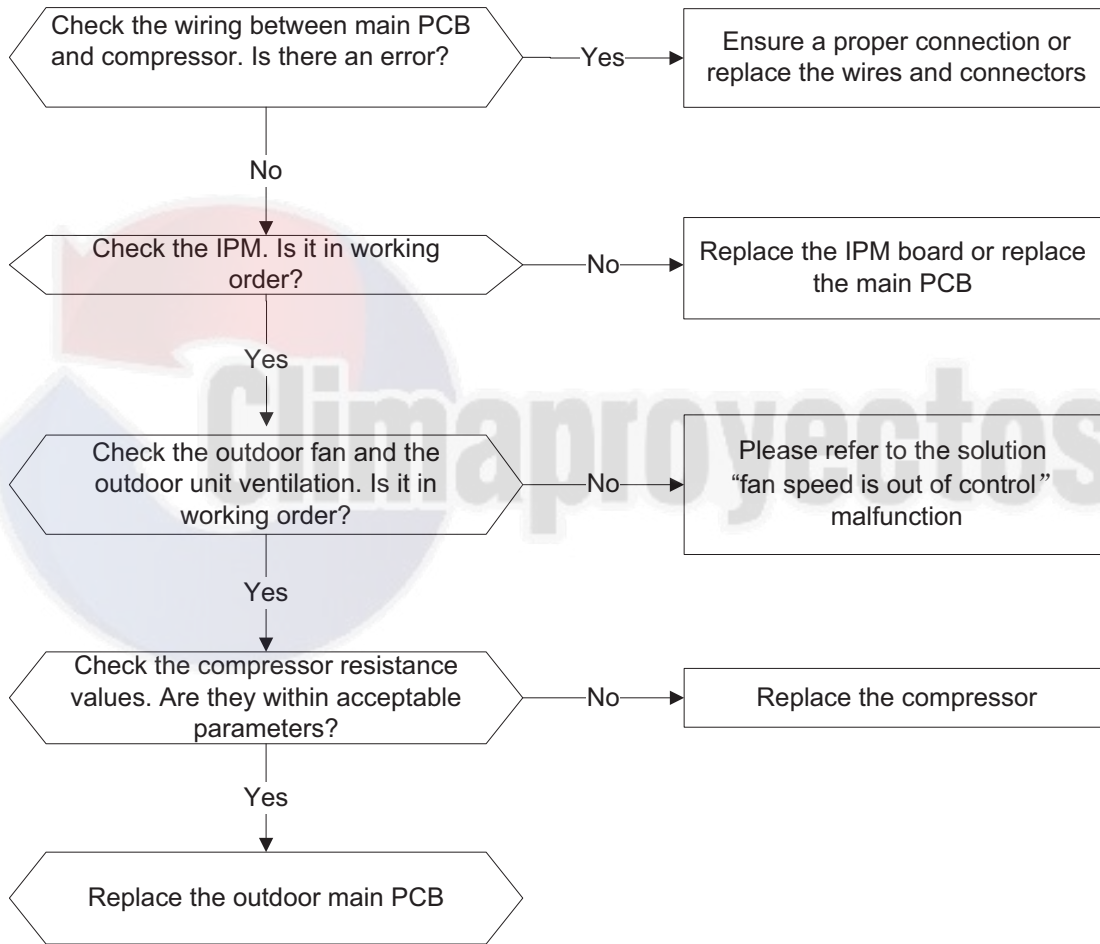

**NOTE:** In figures 21–24 the following is observed:

- U,V,W references the compressor connection point
- P references input voltage
- N references output voltage

## DIAGNOSIS AND SOLUTION (CONT)

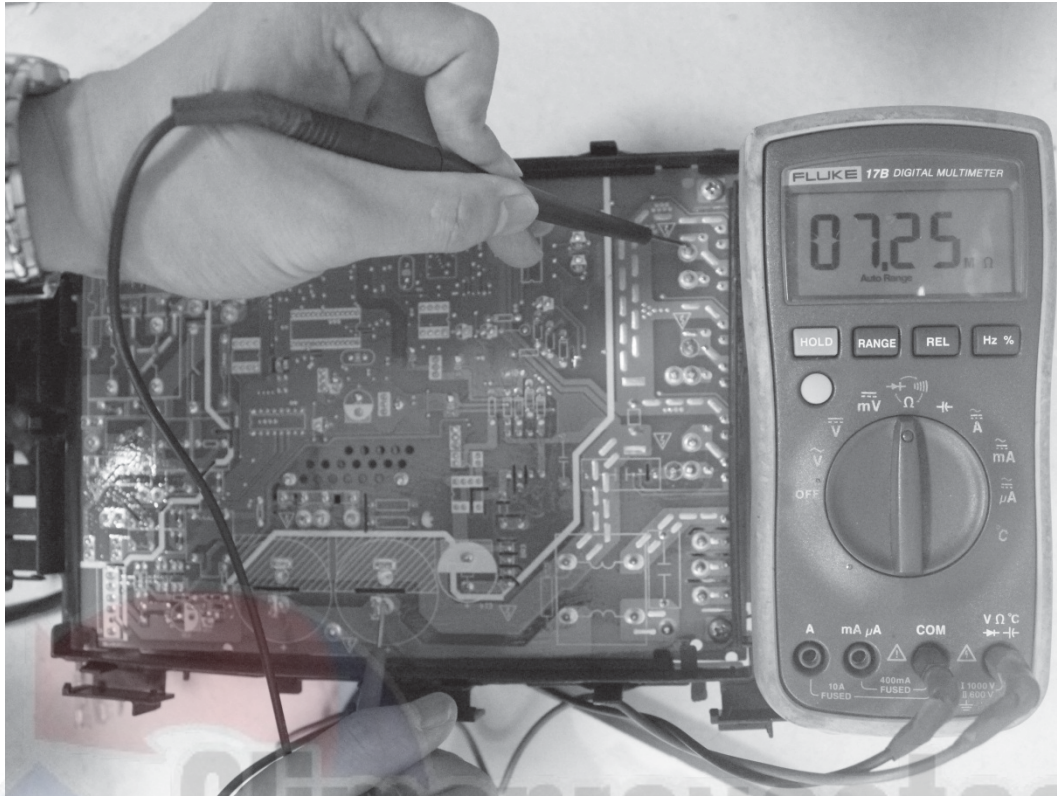

Fig. 21 – P-U

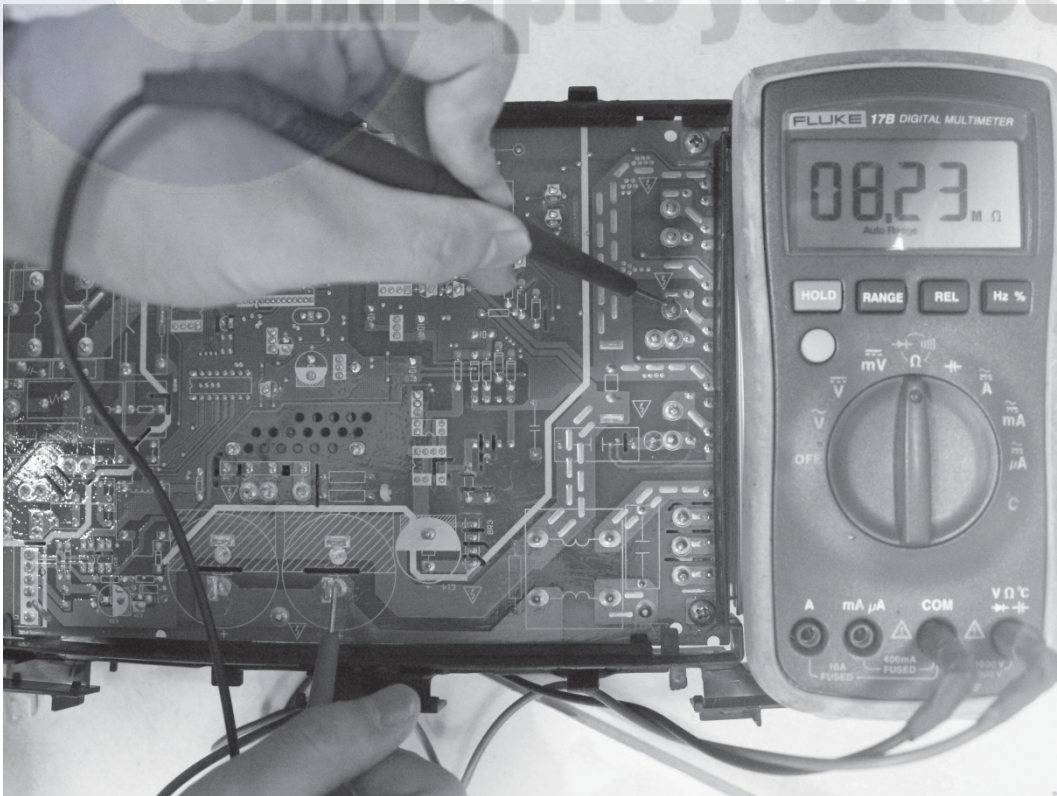

Fig. 22 – P-V



## DIAGNOSIS AND SOLUTION (CONT)

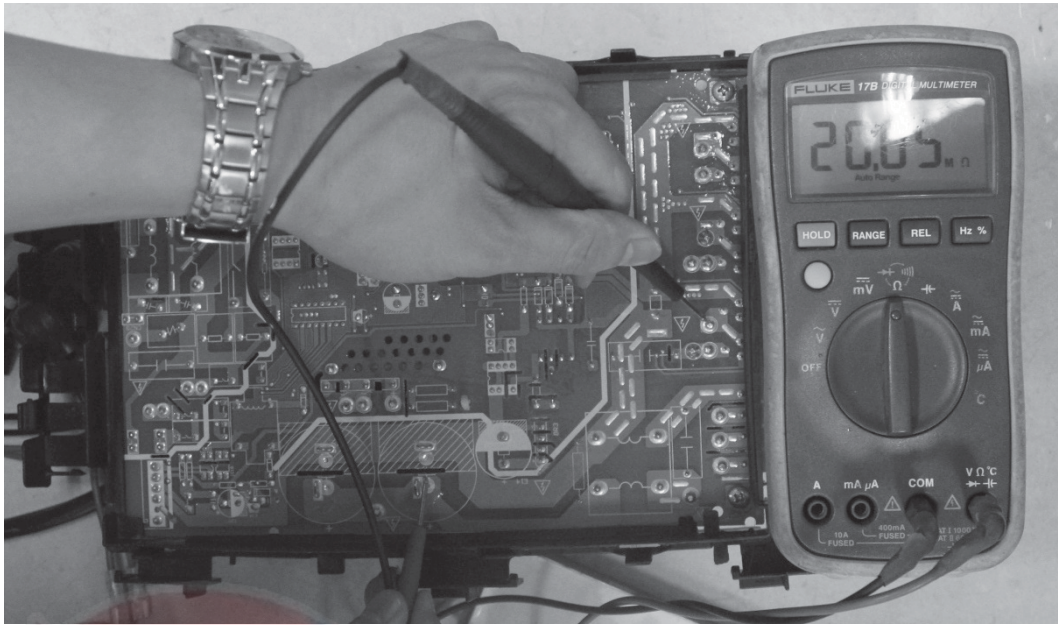

Fig. 23 – P-W

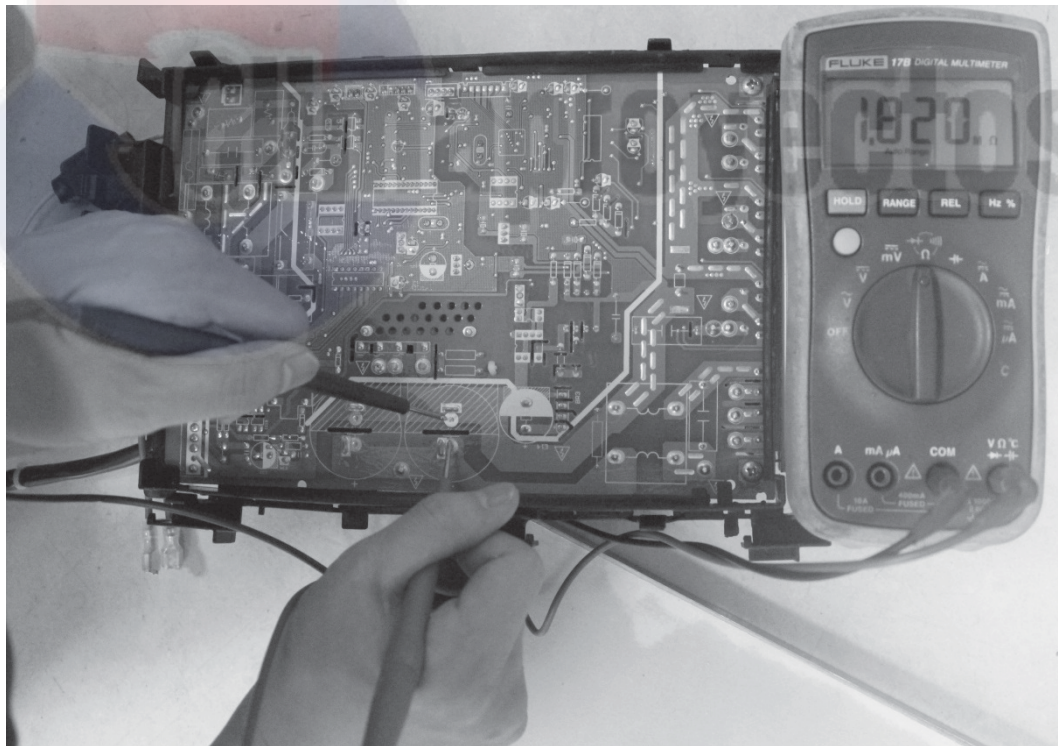

Fig. 24 – P-N

# DIAGNOSIS AND SOLUTION (CONT)

Table 24—Over Voltage or Too Low Voltage Protection Diagnosis and Solution (P1)

<b>Error Code</b>	<b>P1</b>
<b>Malfunction Decision Conditions</b>	An abnormal current rise is detected by checking the specified current detection circuit.
<b>Supposed Causes</b>	<ul style="list-style-type: none"> <li>• Power supply problems</li> <li>• System leakage or blockage</li> <li>• PCB faulty</li> </ul>

## Troubleshooting

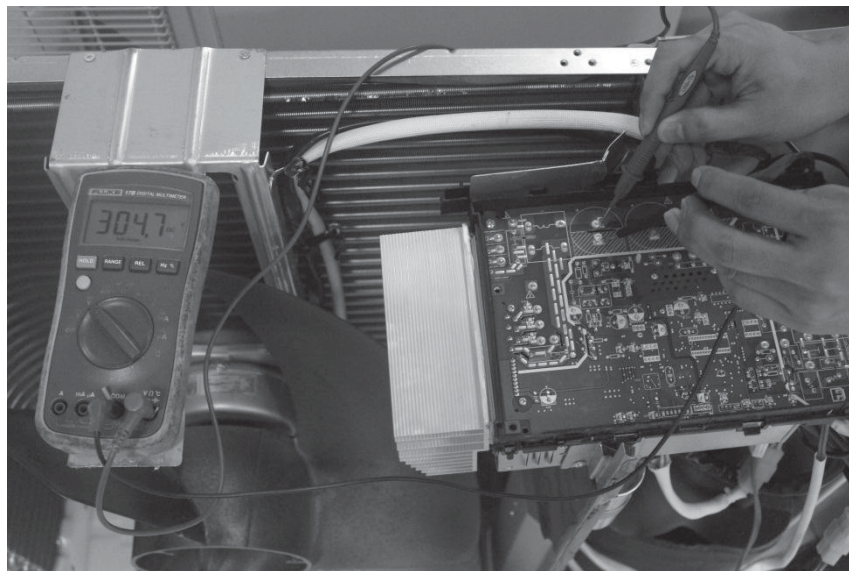
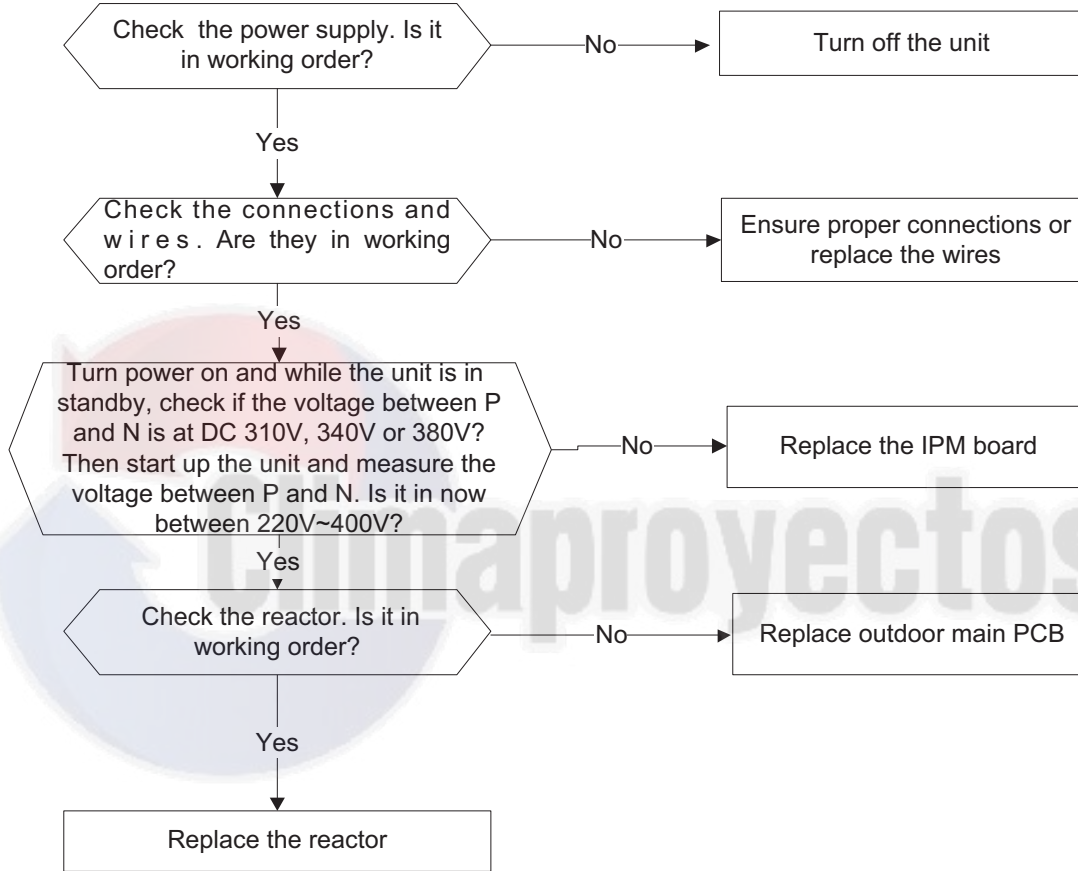

# DIAGNOSIS AND SOLUTION (CONT)

Table 25—High Temperature Protection of Compressor Top Diagnosis and Solution (P2)

<b>Error Code</b>	<b>P2</b>
<b>Malfunction Decision Conditions</b>	If the sampling voltage is not 5V, the LED displays the failure.
<b>Supposed Causes</b>	<ul style="list-style-type: none"> <li>• Power supply problems</li> <li>• System leakage or block</li> <li>• PCB faulty</li> </ul>

## Troubleshooting

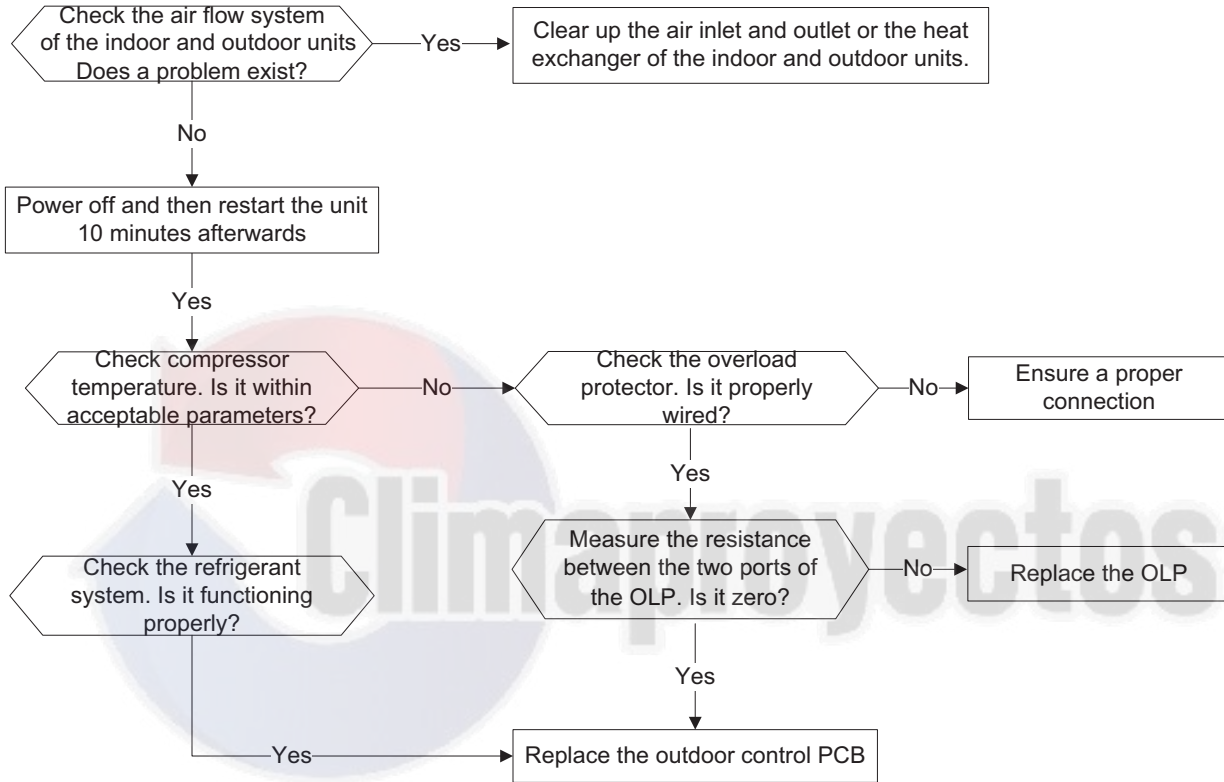

# DIAGNOSIS AND SOLUTION (CONT)

Table 26—Inverter Compressor Drive Error Diagnosis and Solution (P4)

<b>Error Code</b>	<b>P4</b>
<b>Malfunction Decision Conditions</b>	An abnormal inverter compressor drive is detected by a special detection circuit, including communication signal detection, voltage detection, compressor rotation speed signal detection and so on.
<b>Supposed Causes</b>	<ul style="list-style-type: none"> <li>• Wiring mistake</li> <li>• IPM malfunction</li> <li>• Outdoor fan assembly fault</li> <li>• Compressor malfunction</li> <li>• Outdoor PCB faulty</li> </ul>

## Troubleshooting

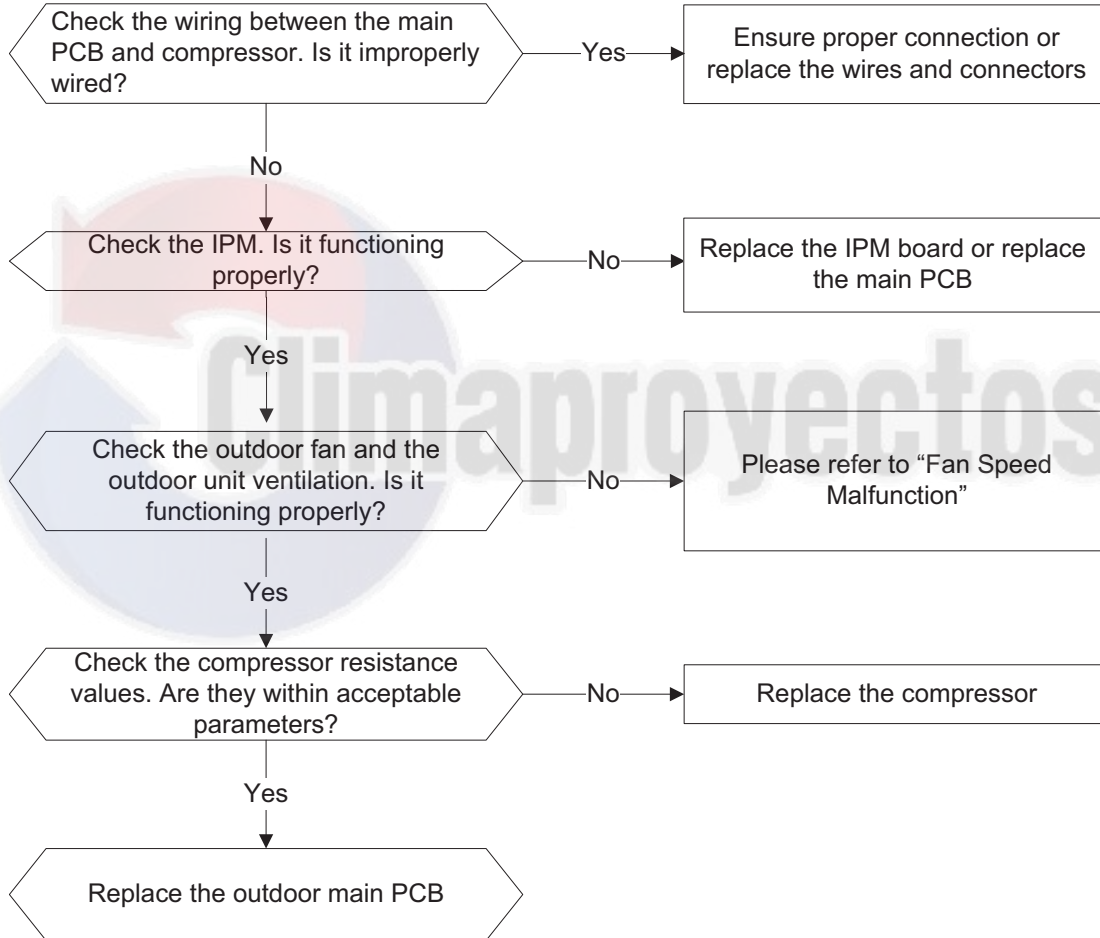

## DIAGNOSIS AND SOLUTION (CONT)

### Main Parts Check

#### 1 Temperature sensor checking

Disconnect the temperature sensor from PCB, measure the resistance value with a tester.

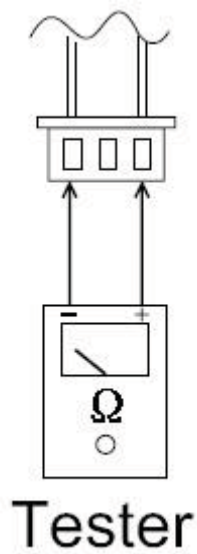

Fig. 25 – Tester

#### Temperature Sensors:

- Room temp. (T1) sensor,
  - Indoor coil temp. (T2) sensor,
  - Outdoor coil temp. (T3) sensor,
  - Outdoor ambient temp. (T4) sensor,
  - Compressor discharge temp. (T5) sensor.
- Measure the resistance value of each winding by using the multi-meter.



## Compressor Checking

Measure the resistance value of each winding by using the tester.

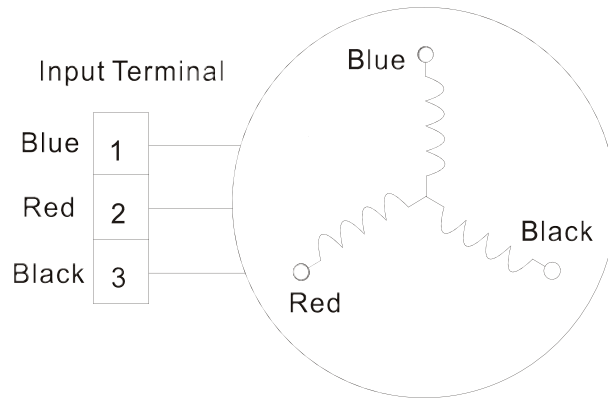

Fig. 26 – Tester

Table 27—Resistance Value

POSITION	RESISTANCE VALUE
	DA110S1C-30FZ
Blue – Red	0.8Ω
Blue – Black	
Red – Blue	



Fig. 27 – Compressor Checking

## IPM Continuity Check

Turn off the power, let the large capacity electrolytic capacitors discharge completely, and dismount the IPM. Use a digital tester to measure the resistance between P and UVWN; UVW and N.

**Table 28—IPM Continuity Check**

DIGITAL TESTER		NORMAL RESISTANCE VALUE	DIGITAL TESTER		NORMAL RESISTANCE VALUE
(+)Red	(-)Black		(+)Red	(-)Black	
P	N	∞ (Several MΩ)	U	N	∞ (Several MΩ)
	U		V		
	V		W		
	W		(+)Red		



# DISASSEMBLY INSTRUCTIONS SIZE 36

No.	Part name	Procedures	Remarks
1	Panel plate	<p>How to remove the panel plate</p> <p>1) Stop the air conditioner and turn off the power breaker.</p> <p>2) Remove the big handle first, then remove the top cover (7 screws).</p> <p>3) Remove the front panel screws (11 screws).</p> <p>4) Remove the right side panel screws (13).</p>	<p>Big handle screws (4)</p> <p>Top panel screws (3), 1 screw is under the big handle</p>  <p>Front panel screws (11)</p> 

## DISASSEMBLY INSTRUCTIONS SIZE 36 (CONT)

2	Fan assembly	<p>How to remove the fan assembly</p> <p>1) Use procedure 1 to remove the panel plate.</p> <p>2) Remove the nut securing the fan, then remove the fan.</p> <p>3) Unfix the hooks and remove the screws. Next, open the electronic control box cover.</p>	 <p>The image shows three sequential steps for removing the fan assembly from a unit. The top photograph shows the internal components with labels: 'fan' pointing to a blue fan, 'Electronic control box' pointing to a black box, and 'compressor' pointing to a component at the bottom. A red arrow points to the fan. The middle photograph is a close-up of the blue fan with a red circle around a central nut, labeled with a circled '2'. The bottom photograph shows the electronic control box cover with three red circles highlighting the screws to be removed, labeled with a circled '3'.</p>
---	--------------	--	--

# DISASSEMBLY INSTRUCTIONS SIZE 36 (CONT)

4) Disconnect the fan motor connector from the electronic control board.

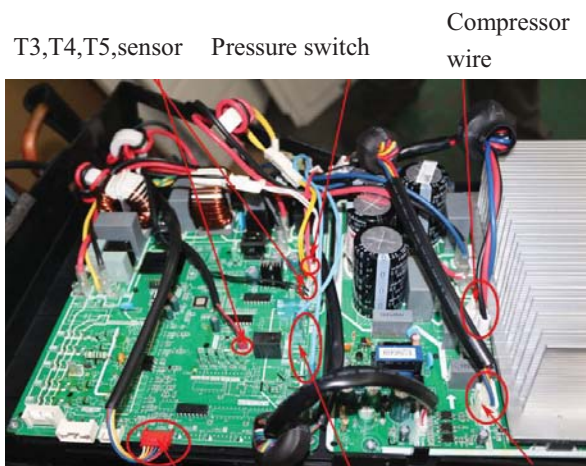

Electronic expansion    4 way valve    Motor wire

5) Remove the fan motor's four screws (4) then remove the motor.

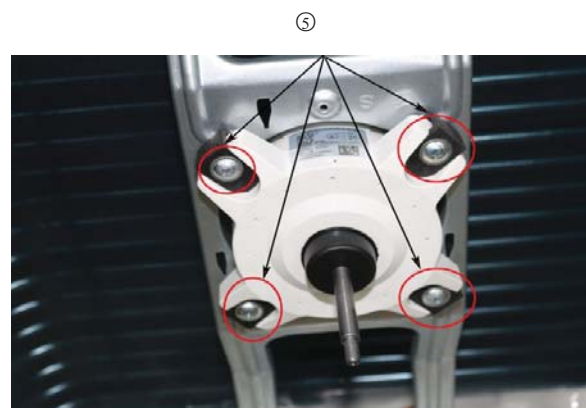
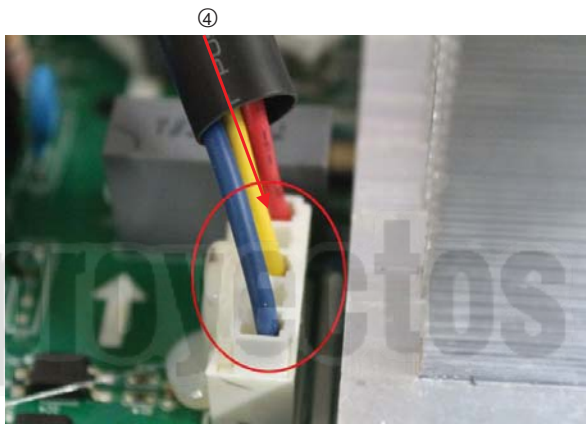



## DISASSEMBLY INSTRUCTIONS SIZE 36 (CONT)

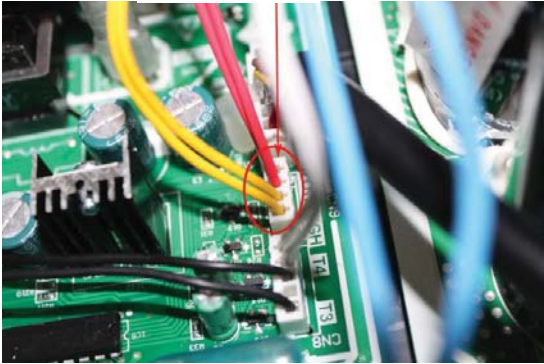
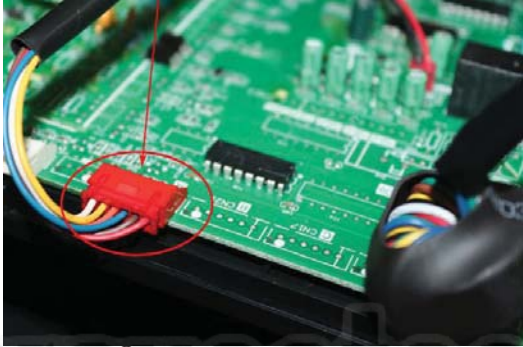
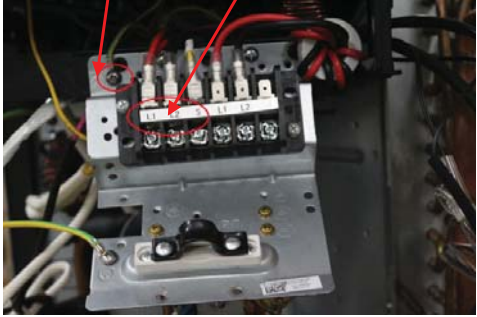

3	Electrical parts	<p>How to remove the electrical parts.</p> <p>1) After completing steps in sections 1 and 2, remove the compressor connector.</p> <p>2) Pull out the two blue wires connected with the four-way valve.</p> <p>3) Pull out the condenser coil temp. sensor (T3) connectors, outdoor ambient temp. sensor (T4), and the discharge temp. sensor (T5).</p>	<p>①</p>  <p>②</p>  <p>③</p> 
---	------------------	--	---

## DISASSEMBLY INSTRUCTIONS SIZE 36 (CONT)

		<p>4) Disconnect the pressure switch connector.</p> <p>5) Disconnect the electronic expansion valve wire from the control board.</p> <p>6) Remove the ground wires.</p> <p>7) Remove the wires (1,2,3 or L1,L2, S). Next, remove the electronic control box.</p>	 <p>④</p>  <p>⑤</p>  <p>⑥</p> <p>⑦</p>
--	--	--	--

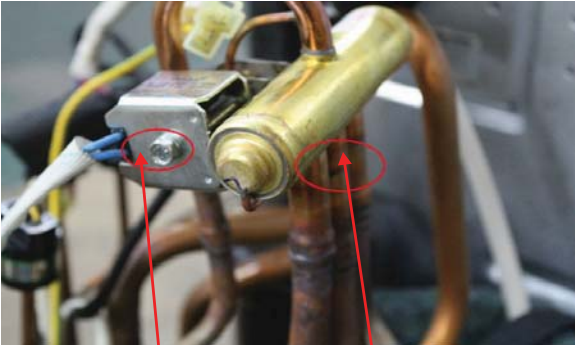

## DISASSEMBLY INSTRUCTIONS SIZE 36 (CONT)

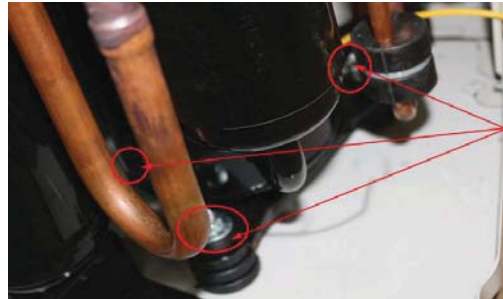
4	Four-way valve	<p>How to remove the four-way valve.</p> <ol style="list-style-type: none"><li>1) Complete the steps in sections 1 and 3.</li><li>2) Recover refrigerant from the refrigerant circuit.</li><li>3) Remove the coil screw and then remove the coil.</li><li>4) Detach the welded parts of the four-way valve and pipe.</li><li>5) Remove the four-way valve assembly.</li></ol>	<p>The picture of the four-way valve may differ from your actual valve.</p>  <p>③ ④</p>
5	Compressor	<p>How to remove the compressor</p> <ol style="list-style-type: none"><li>1) After completing the steps in sections 1 and 3, recover the refrigerant from the refrigerant circuit.</li><li>2) Remove the discharge pipe and the suction pipe with a burner.</li><li>3) Remove the hex nuts and washers securing the compressor on the bottom plate.</li><li>4) Lift the compressor from the base pan assembly.</li></ol>	 <p>②</p>  <p>③</p>



# DISASSEMBLY INSTRUCTIONS SIZE 48

No.	Part name	Procedures	Remarks
1	Fan assembly	<p>How to remove the fan assembly.</p> <ol style="list-style-type: none"> <li>1) Stop the air conditioner and turn off the power breaker.</li> <li>2) Remove the air outlet grille screws (8).</li> <li>3) Remove the hex nut securing the fan.</li> <li>4) Remove the fan.</li> <li>5) Remove the top cover screws (4) then remove the top cover.</li> </ol>	  <p>Screws of top cover</p> 

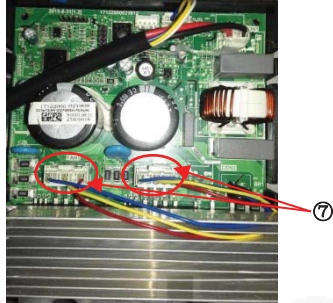
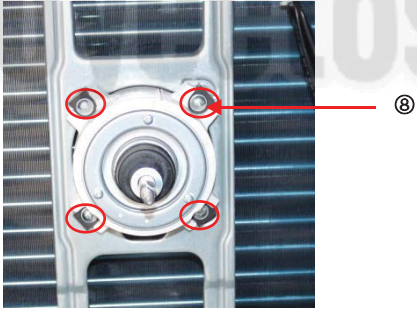
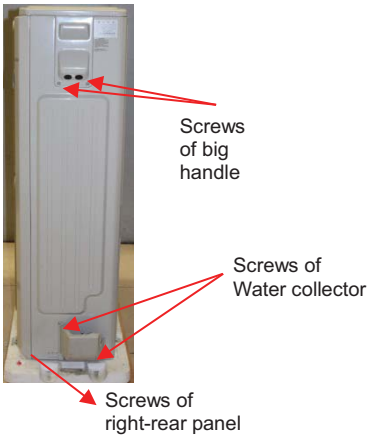
# DISASSEMBLY INSTRUCTIONS SIZE 48 (CONT)

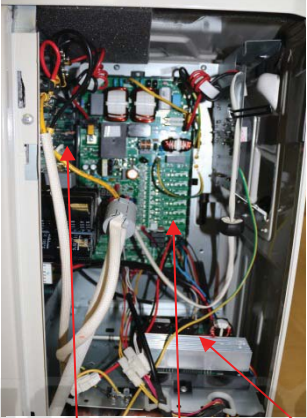

		<p>6) Remove the right front side screws and the right front side panel (1 screw).</p> <p>7) Disconnect the fan motor connectors FAN (3p, white) and FAN2 (3p, white) from the DC motor driver board.</p> <p>8) Remove the fan motor after unfastening the securing screws.</p>	  
2	Panel plate	<p>How to remove the panel plate.</p> <p>1) Remove the big handle (2 screws) and the water collector (2 screws).</p> <p>2) Remove the terminal board screws (2) and the right-rear panel screws (7) and remove the right-rear panel.</p>	

# DISASSEMBLY INSTRUCTIONS SIZE 48 (CONT)

			 <p>Screws of right-rear panel</p>
3	Electrical parts	<p>How to remove the electrical parts.</p> <ol style="list-style-type: none"> <li>1) Complete steps 5 - 6 in section 1 and section 2.</li> <li>2) Disconnect the fan motor connector (5p, white) from the IPM board.</li> <li>3) Disconnect the following eight (8) connection wires and connectors between the IPM and the other parts.</li> </ol>	 <p>IPM board PCB board DC Fan Driver board</p>  <p>②</p>



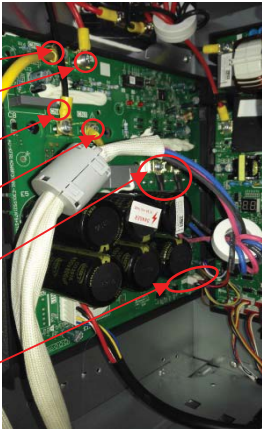

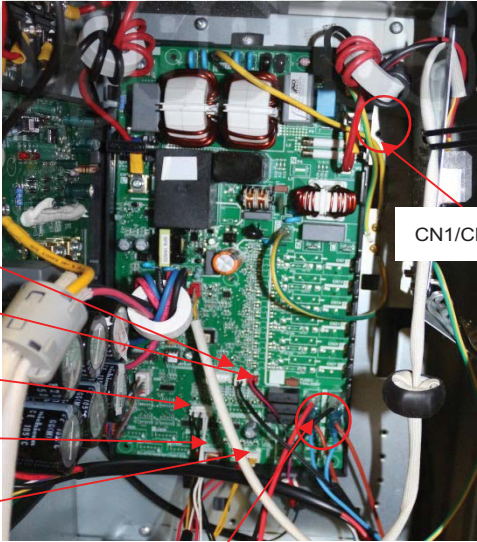
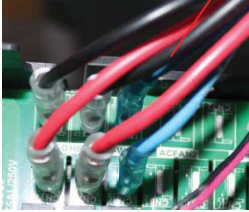
# DISASSEMBLY INSTRUCTIONS SIZE 48 (CONT)

		<p>CN2(yellow)</p> <p>CN1(red)</p> <p>CN6(black)</p> <p>CN3(yellow)</p> <p>U、V、W(black)</p> <p>CN9(10p,white)</p> <p>4) Remove the screws securing the IPM board and remove the IBM board.</p> <p>5) Disconnect the connectors and wires connected from the PCB and other parts.</p> <p>Connectors:</p> <p>CN8: Discharge temperature sensor (2p,white)</p> <p>CN12: Heatsink temperature sensor(2p,red)</p> <p>CN9:T3/T4 temperature sensor (2p/2p,white)</p> <p>CN15: Electronic expansive valve (6p,red)</p> <p>CN10: High and low pressure switch (2p/2p, white)</p> <p>Wires:</p> <p>CN17/CN18: 4-way valve (blue-blue)</p> <p>CN19/CN20: connected to crankcase heating cable. (black-red)</p> <p>CN24/CN25: Electric heater of chassis (orange-orange)</p> <p>CN1:L-IN (red or white)</p> <p>CN3:N-IN (black)</p>	    <p>CN1/CN3</p> <p>CN17/CN18</p> <p>CN19/CN20</p> <p>CN24/CN25</p>
--	--	--	--

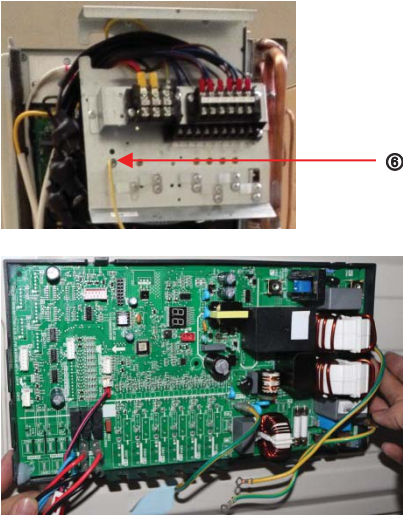
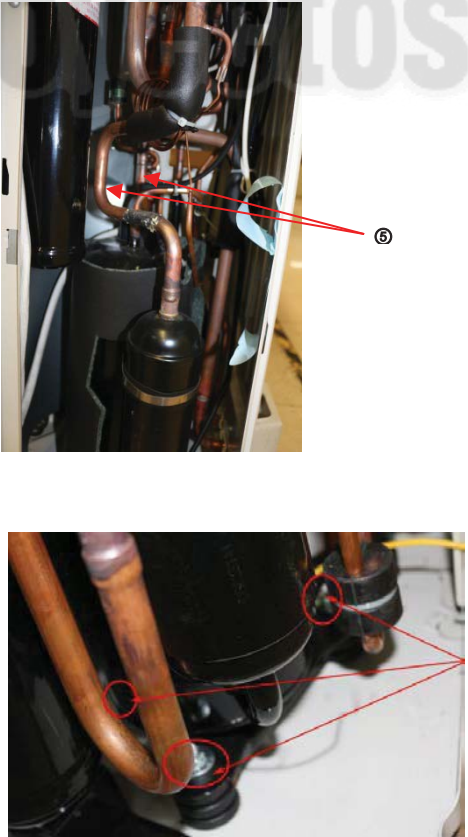
# DISASSEMBLY INSTRUCTIONS SIZE 48 (CONT)

		<p>6) Disconnect the grounding wire (yellow-green) after removal of the big handle.</p> <p>7) Remove the PCB board.</p>	
4	Compressor	<p>How to remove the compressor.</p> <ol style="list-style-type: none"> <li>1) Complete steps 5 - 6 in section and section 2.</li> <li>2) Extract the refrigerant gas.</li> <li>3) Remove the sound insulation material and crankcase heating cable.</li> <li>4) Remove the compressor terminal cover and disconnect the crankcase electric heater wires and compressor from the terminal.</li> <li>5) Remove the discharge pipe and suction pipe with a burner.</li> <li>6) Remove the hex nuts and washers securing the compressor to the bottom plate.</li> <li>7) Lift the compressor.</li> </ol>	

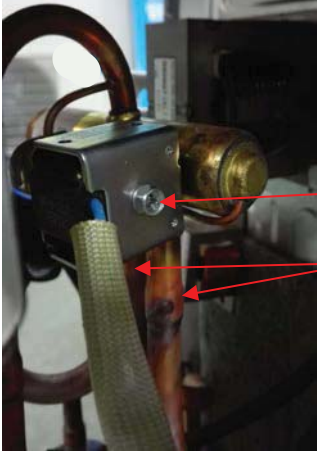
## DISASSEMBLY INSTRUCTIONS SIZE 48 (CONT)

5	The 4-way valve	<p>How to remove the 4-way valve</p> <ol style="list-style-type: none"><li>1) Complete steps 5 - 6 of section 1 and section 2.</li><li>2) Extract the refrigerant gas.</li><li>3) Remove the electrical parts in section 3.</li><li>4) Remove the coil screw and remove the coil.</li><li>5) Detach the welded parts of the 4-way valve and pipe.</li></ol>	 <p>Coil</p> <p>Welded parts</p>
6	The expansion valve	<p>How to remove the expansion valve.</p> <ol style="list-style-type: none"><li>1) Complete the steps in sections 1 - 2.</li><li>2) Remove the electrical parts described in section 3.</li><li>3) Remove the coil.</li><li>4) Detach the expansion valves welded parts and pipes.</li></ol>	 <p>Expansion valves</p>



