



Service and Maintenance Instructions

CONTENTS

<p>SAFETY CONSIDERATIONS 2</p> <p>UNIT ARRANGEMENT AND ACCESS 2</p> <p> General 2</p> <p> Routine Maintenance 3</p> <p> Seasonal Maintenance 3</p> <p>SUPPLY FAN (BLOWER) SECTION 4</p> <p> Supply Fan Assembly 4</p> <p>STAGED AIR VOLUME (SAV) CONTROL: 2-SPEED FAN WITH VARIABLE FREQUENCY DRIVE (VFD) 6</p> <p> Staged Air Volume (SAV) Indoor Fan Speed System 6</p> <p> Identifying Factory Option 6</p> <p> Unit Installation with SAV Option 6</p> <p>ADDITIONAL VFD INSTALLATION AND TROUBLESHOOTING 6</p> <p>MOTOR 6</p> <p> Replacing the Motor 7</p> <p> Changing Fan Wheel Speed by Changing Pulleys 7</p> <p>CONDENSER COIL SERVICE 8</p> <p> Round Tube Plate Fin (RTPF) Condenser Coil 8</p> <p> Recommended Condenser Coil Maintenance and Cleaning 8</p> <p>EVAPORATOR COILS 9</p> <p> Coil Maintenance and Cleaning Recommendation 9</p> <p> Refrigerant System Pressure Access Ports 10</p> <p>HUMIDI-MIZER® ADAPTIVE DEHUMIDIFICATION SYSTEM 11</p> <p> Humidi-MiZer System Components 11</p> <p> Operating Sequences 11</p> <p> Humidi-MiZer Modes 12</p> <p>THERMOSTATIC EXPANSION VALVE (TXV) 16</p> <p> TXV Operation 16</p> <p> Refrigerant System Pressure Access Ports 17</p> <p>PURON (R-410A) REFRIGERANT 18</p> <p> Refrigerant Charge 18</p> <p> Using the Cooling Charging Charts 18</p> <p>COOLING CHARGING CHARTS 19</p> <p>COMPRESSORS 23</p> <p> Lubrication 23</p> <p> Replacing the Compressor 23</p> <p> Compressor Rotation 23</p> <p> Filter Drier 23</p> <p> Adjusting the Condenser-Fan 23</p> <p>TROUBLESHOOTING THE COOLING SYSTEM 24</p> <p>CONVENIENCE OUTLETS 25</p> <p> Non-Powered Type 25</p> <p> Unit-Powered Type 25</p>	<p> Wet in Use Convenience Outlet Cover 25</p> <p> GFCI Maintenance 25</p> <p> Fuse On Powered Type 26</p> <p> Using Unit-Mounted Convenience Outlets 26</p> <p> Installing a Weatherproof Cover 26</p> <p>SMOKE DETECTORS 26</p> <p> System 26</p> <p> Controller 26</p> <p> Sensor 27</p> <p> Smoke Detector Locations 27</p> <p> FIOP Smoke Detector Wiring and Response 28</p> <p> Sensor and Controller Tests 29</p> <p> Detector Cleaning 30</p> <p>INDICATORS 31</p> <p> Normal State 31</p> <p> Alarm State 31</p> <p> Resetting Alarm and Trouble Condition Trips 32</p> <p> Troubleshooting 32</p> <p>PROTECTIVE DEVICES 32</p> <p> Compressor Protection 32</p> <p>SUPPLY (INDOOR) FAN MOTOR PROTECTION 32</p> <p> Control Circuit, 24v 33</p> <p> PremierLink™ Control 33</p> <p> RTU Open Control System 33</p> <p>ECONOMISER SYSTEMS 33</p> <p> EconoMi\$er IV Standard Sensors 37</p> <p> EconoMi\$er® X (Factory Option) 42</p> <p>PRE-START-UP/START-UP 56</p> <p>START-UP, GENERAL 56</p> <p> Unit Preparation 56</p> <p> Additional Installation/Inspection 56</p> <p> Return-Air Filters 56</p> <p> Outdoor-Air Inlet Screens 56</p> <p> Compressor Mounting 57</p> <p> Internal Wiring 57</p> <p> Refrigerant Service Ports 57</p> <p> Compressor Rotation 57</p> <p> Cooling 57</p> <p> Ventilation (Continuous Fan) 57</p> <p>START-UP, PREMIERLINK CONTROLS 57</p> <p>START-UP, RTU-OPEN CONTROLS 57</p> <p>FASTENER TORQUE VALUES 57</p> <p>APPENDIX A — MODEL NUMBER NOMENCLATURE 58</p> <p>APPENDIX B — PHYSICAL DATA 60</p> <p>APPENDIX C — FAN PERFORMANCE 69</p> <p>APPENDIX D — WIRING DIAGRAMS 79</p> <p>APPENDIX E — MOTORMASTER SENSOR LOCATIONS 92</p> <p>START-UP CHECKLIST CL-1</p>
--------------------------------------------------------------------------------------------------------------------------------------------------------------------------------------------------------------------------------------------------------------------------------------------------------------------------------------------------------------------------------------------------------------------------------------------------------------------------------------------------------------------------------------------------------------------------------------------------------------------------------------------------------------------------------------------------------------------------------------------------------------------------------------------------------------------------------------------------------------------------------------------------------------------------------------------------------------------------------------------------------------------------------------------------------------------------------------------------------------------------------------------------------------------------------------------------------------------------------------------------------------------------------------------------------------------------------------------------------------------------------------------------------------------------------------------------------------------------------------------------------------------------------------------------------------------------------------------------------------------------------------------------------------------------------------------------------------------------------------------------------------------------------------------------------------------------------------------------------------------------------------------------------------------------------------------------------------------------------------------------------------------------------------------------------------------------------	--------------------------------------------------------------------------------------------------------------------------------------------------------------------------------------------------------------------------------------------------------------------------------------------------------------------------------------------------------------------------------------------------------------------------------------------------------------------------------------------------------------------------------------------------------------------------------------------------------------------------------------------------------------------------------------------------------------------------------------------------------------------------------------------------------------------------------------------------------------------------------------------------------------------------------------------------------------------------------------------------------------------------------------------------------------------------------------------------------------------------------------------------------------------------------------------------------------------------------------------------------------------------------------------------------------------------------------------------------------------------------------------------------------------------------------------------------------------------------------------------------------------------------------------------------------------------------------------------------------------------------------------------------------------------------------------------------------------------------------------------------------------------------------------------------------------------------------------------------------------------------------------------------------------------------------------------------------------------------------------------------------------------------------------------------------------------------------------------------------------------------------------------------------------------

SAFETY CONSIDERATIONS

Installation and servicing of air-conditioning equipment can be hazardous due to system pressure and electrical components. Only trained and qualified service personnel should install, repair, or service air-conditioning equipment.

Untrained personnel can perform basic maintenance functions of cleaning coils and filters and replacing filters. All other operations should be performed by trained service personnel. When working on air-conditioning equipment, observe precautions in the literature, tags and labels attached to the unit, and other safety precautions that may apply.

Follow all safety codes, including ANSI (American National Standards Institute) Z223.1. Wear safety glasses and work gloves. Use quenching cloth for unbrazing operations. Have fire extinguisher available for all brazing operations.

It is important to recognize safety information. This is the safety-alert symbol . When you see this symbol on the unit and in instructions or manuals, be alert to the potential for personal injury.

Understand the signal words DANGER, WARNING, CAUTION, and NOTE. These words are used with the safety-alert symbol. DANGER identifies the most serious hazards which **will** result in severe personal injury or death. WARNING signifies hazards which **could** result in personal injury or death. CAUTION is used to identify unsafe practices, which **may** result in minor personal injury or product and property damage. NOTE is used to highlight suggestions which **will** result in enhanced installation, reliability, or operation.

CAUTION

PERSONAL INJURY HAZARD

Failure to follow this caution may result in personal injury. Sheet metal parts may have sharp edges or burrs. Use care and wear appropriate protective clothing, safety glasses and gloves when handling parts and servicing air conditioning equipment.

WARNING

FIRE, EXPLOSION HAZARD

Failure to follow this warning could result in death, serious personal injury and/or property damage. Never use air or gases containing oxygen for leak testing or for operating refrigerant compressors. Pressurized mixtures of air or gases containing oxygen can lead to an explosion.

WARNING

FIRE, EXPLOSION HAZARD

Failure to follow this warning could result in death, serious personal injury and/or property damage. Never use non-certified refrigerants in this product. Non-certified refrigerants could contain contaminants that could lead to unsafe operating conditions. Use **ONLY** refrigerants that conform to AHRI Standard 700.

WARNING

UNIT OPERATION AND SAFETY HAZARD

Failure to follow this warning could cause personal injury, death and/or equipment damage.

This system uses R-410A refrigerant, which has higher pressures than R-22 and other refrigerants. No other refrigerant may be used in this system. Gage set, hoses, and recovery system must be designed to handle R-410A refrigerant. If unsure about equipment, consult the equipment manufacturer.

CAUTION

UNIT DAMAGE HAZARD

Failure to follow this caution may result in reduced unit performance or unit shutdown.

High velocity water from a pressure washer, garden hose, or compressed air should never be used to clean a coil. The force of the water or air jet will bend the fin edges and increase airside pressure drop.

IMPORTANT: Failure to follow this ALERT could result in an unnecessary evacuation of the facility.

Pressing the controller's test/reset switch for longer than seven seconds will put the duct detector into the alarm state and activate all automatic alarm responses.

CAUTION

ELECTRICAL SHOCK HAZARD

Failure to follow this warning could cause personal injury or death.

Before performing service or maintenance operations on the fan system, shut off all unit power and lockout/tag-out the unit disconnect switch. **DO NOT** reach into the fan section with power still applied to unit.

WARNING

ELECTRICAL OPERATION HAZARD

Failure to follow this warning could result in personal injury or death.

Units with convenience outlet circuits may use multiple disconnects. Check convenience outlet for power status before opening unit for service. Locate its disconnect switch, if appropriate, and open it. Lock-out and tag-out this switch, if necessary.

IMPORTANT: Lockout/tag-out is a term used when electrical power switches are physically locked, preventing power to the unit. A placard is placed on the power switch, alerting personnel that the power is disconnected.

UNIT ARRANGEMENT AND ACCESS

General

Figures 1 and 2 show general unit arrangement and access locations.

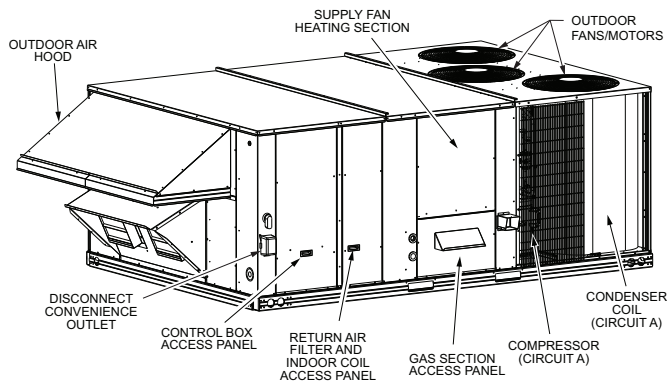

Fig. 1 — Access Panels and Components, Front

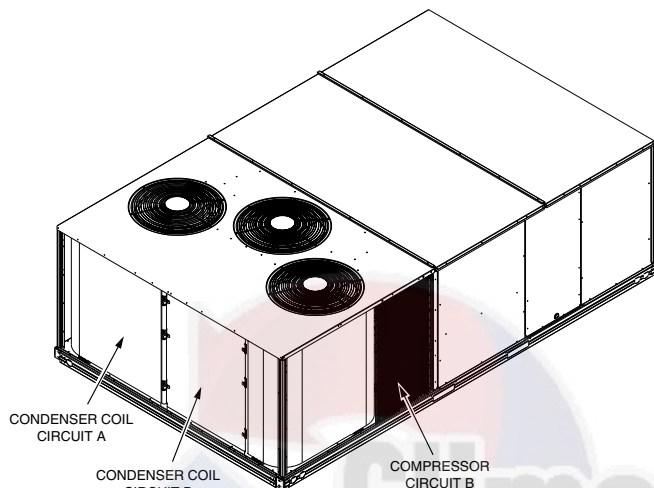

Fig. 2 — Typical Access Panel Locations, Rear

Routine Maintenance

These items should be part of a routine maintenance program, to be checked every month or two, until a specific schedule for each can be identified for this installation:

QUARTERLY INSPECTION (AND 30 DAYS AFTER INITIAL START)

The 50TC units should be inspected and serviced every three months.

- Return air filter replacement
- Outdoor hood inlet filters cleaned
- Belt tension checked
- Belt condition checked
- Pulley alignment checked
- Fan shaft bearing locking collar tightness checked
- Condenser coil cleanliness checked
- Condensate drain checked

Seasonal Maintenance

These items should be checked at the beginning of each season (or more often if local conditions and usage patterns dictate).

AIR CONDITIONING

- Condenser fan motor mounting bolts tightness
- Compressor mounting bolts
- Condenser fan blade positioning
- Control box cleanliness and wiring condition
- Wire terminal tightness
- Refrigerant charge level

- Evaporator coil cleaning
- Evaporator blower motor amperage

HEATING

- Heat exchanger flue passageways cleanliness
- Gas burner condition
- Gas manifold pressure
- Heating temperature rise

ECONOMIZER OR OUTSIDE AIR DAMPER

- Inlet filters condition
- Check damper travel (economizer)
- Check gear and dampers for debris and dirt

AIR FILTERS AND SCREENS

Each unit is equipped with return air filters. If the unit has an economizer, it will also have an outside air screen. If a manual outside air damper is added, an inlet air screen will also be present.

Each of these filters and screens will need to be periodically replaced or cleaned.

RETURN AIR FILTERS

Return air filters are disposable fiberglass media type. Access to the filters is through the small lift-out panel located on the rear side of the unit, above the evaporator/return air access panel. (See Fig. 1.)

CAUTION

EQUIPMENT DAMAGE HAZARD

Failure to follow this CAUTION can result in premature wear and damage to equipment.

DO NOT OPERATE THE UNIT WITHOUT THE RETURN AIR FILTERS IN PLACE.

Dirt and debris can collect on heat exchangers and coils possibly resulting in a small fire. Dirt buildup on components can cause excessive current used resulting in motor failure.

Removing the Return Air Filters

1. Remove the return air filter and indoor coil access panel. See Fig. 1.
2. Reach inside and remove filters from the filter rack.
3. Replace these filters as required with similar replacement filters of same size.
4. Re-install the return air filter and indoor coil access panel.

OUTDOOR AIR HOOD

Outside air hood inlet screens are permanent aluminum-mesh type filters. See Fig. 2. Inspect these screens for cleanliness. Remove the screens when cleaning is required. Clean by washing with hot low-pressure water and soft detergent and replace all screens before restarting the unit. Observe the flow direction arrows on the side of each filter frame.

ECONOMIZER AND MANUAL OUTSIDE AIR SCREENS

This air screen is retained by spring clips under the top edge of the hood. (See Fig. 3.)

To remove the filter, remove screws in horizontal filter retainers on leading edge of hood. Slide filters out. To re-install filters, slide clean or new filters into hood side retainers. Once positioned, re-install horizontal filter retainer.

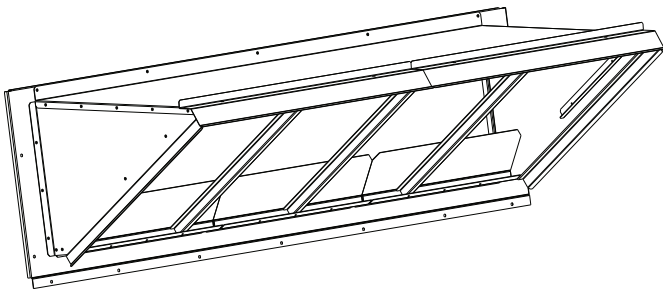

Fig. 3 — Filter Installation

Economizer Inlet Air Screen

This air screen is retained by spring clips under the top edge of the hood. (See Fig. 4.)

Remove screens by removing the screws in the horizontal clips on the leading edge of the hood. Slide the filters out. See Fig. 4.

Install the filters by sliding clean or new filters into the hood side retainers. Once positioned, re-install the horizontal clips.

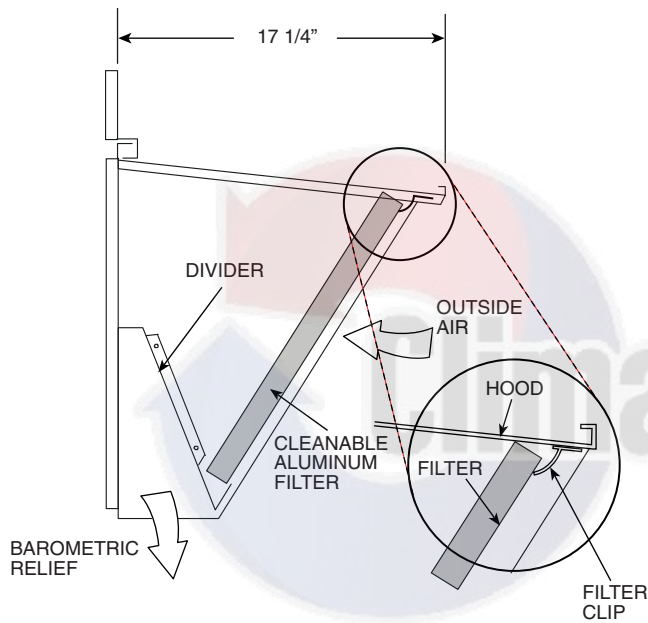

Fig. 4 — Inlet Air Screen Installation

SUPPLY FAN (BLOWER) SECTION

⚠ CAUTION
ELECTRICAL SHOCK HAZARD
Failure to follow this warning could cause personal injury or death.
Before performing service or maintenance operations on the fan system, shut off all unit power and lockout/tag-out the unit disconnect switch. DO NOT reach into the fan section with power still applied to unit.

Supply Fan Assembly

The supply fan system consists of two forward-curved centrifugal blower wheels mounted on a solid blower shaft that is supported by two greasable pillow block concentric bearings. A fixed-pitch driven fan pulley is attached to the fan shaft and an adjustable-pitch driver pulley is mounted on the motor. The pulleys are connected using a V-belt. (See Fig. 5.)

VERTICAL SUPPLY MODELS

The two fan wheels used on the vertical supply models are the same: 15-in. diameter x 15-in. width. This arrangement provides uniform airflow distribution across the width of the evaporator coil, electric heater, and into the supply duct.

HORIZONTAL SUPPLY MODELS

The horizontal supply models have two different fan wheel sizes on a single shaft. The front side wheel is 18-in. diameter x 15-in. wide, while the rear side fan is 15-in. diameter x 11-in. wide. This arrangement promotes uniform airflow across the width of the evaporator coil and heater assembly while using a supply outlet on the rear side of the unit.

NOTE: This major difference in the fan system design makes it impossible to field-convert the 50TC unit's supply fan outlet configuration.

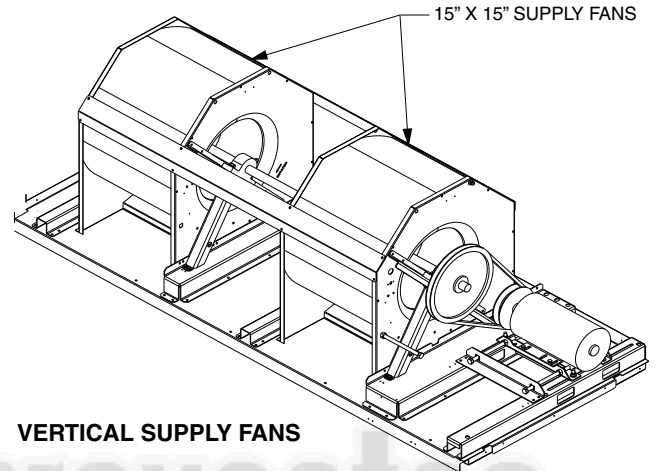

VERTICAL SUPPLY FANS

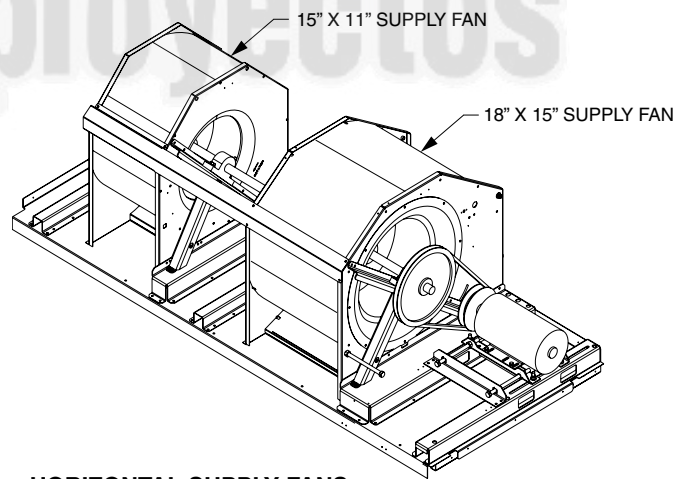

HORIZONTAL SUPPLY FANS

Fig. 5 — Supply Fan Arrangements

BELT

Check the belt condition and tension quarterly. Inspect the belt for signs of cracking, fraying or glazing along the inside surfaces. Check belt tension by using a spring-force tool, such as Browning's "Belt Tension Checker" (P/N 1302546 or equivalent tool); tension should be 6 lb at a 5/8-in. (1.6 cm) deflection when measured at the center line of the belt span. This point is at the center of the belt when measuring the distance between the motor shaft and the blower shaft.

NOTE: Without the spring-tension tool, place a straight edge across the belt surface at the pulleys, then push down on the belt at mid-span using one finger until a 1/2-in. (1.3 cm) deflection is reached.

Adjusting the Belt Tension

Use the following steps to adjust the V-belt tension. See Fig. 6.

1. Loosen the four motor mounting nuts that attach the motor to the blower rail.
2. Loosen the two jack bolt locking nuts beneath the motor mounting plate. Turn the jack bolt locking nut counterclockwise to loosen.
3. Turn the jack bolts counterclockwise to loosen and clockwise to tighten.
4. Adjust the V-belt for proper tension.
5. Make sure the fan shaft and motor shaft are parallel before tightening the motor mount nuts. See Fig. 6.
6. Make adjustments as necessary.
7. Tighten the four motor mounting nuts.
8. Check the V-belt tension. Make adjustments as necessary.
9. Re-tighten the four motor mounting nuts.
10. Tighten both jack bolt locking nuts securely.

Replacing the V-belt

1. Use a belt with same section type or similar size. Do not substitute a “FHP” or notched type V-belt.
2. Loosen (turn counterclockwise) the motor mounting plate front bolts and rear bolts. See Fig. 7.

⚠ CAUTION

EQUIPMENT DAMAGE HAZARD

Failure to follow this CAUTION can result in premature wear and damage to equipment.

Do not use a screwdriver or a pry bar to place the new V-belt in the pulley groove. This can cause stress on the V-belt and the pulley resulting in premature wear on the V-belt and damage to the pulley.

3. Loosen (turn counterclockwise) the jack bolt lock nuts. Loosen (turn counterclockwise) the jack bolts, relieving the belt tension and allowing easy removal of the belt by hand.
4. Remove the belt by gently lifting the old belt over one of the pulleys.
5. Install the new belt by gently sliding the belt over both pulleys, then tighten (turn clockwise) the jack bolts, sliding the motor plate away from the fan housing until proper belt tension is achieved.
6. Check the alignment of the pulleys, adjust if necessary. See Fig. 6.
7. Tighten all bolts attaching the motor to the motor plate.
8. Tighten all jack bolt jam nuts by turning clockwise.
9. Check the tension after a few hours of runtime and re-adjust as required. See Fig. 7.

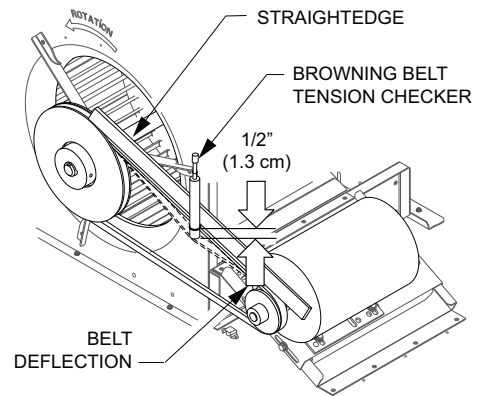

Fig. 6 — Checking Blower Motor Belt Tension

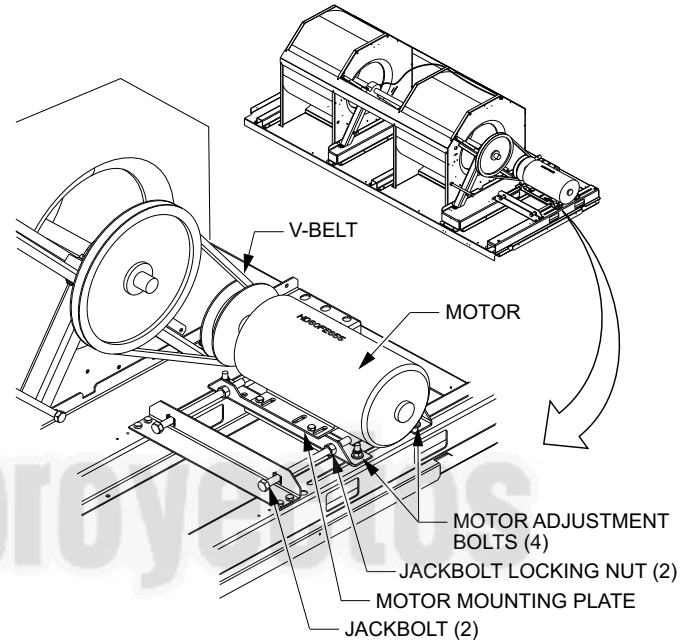

Fig. 7 — Belt Drive Motor Mounting

ADJUSTABLE-PITCH PULLEY ON MOTOR

The motor pulley is an adjustable-pitch type that allows a servicer to implement changes in the fan wheel speed to match as-installed ductwork systems. The pulley consists of a fixed flange side that faces the motor (secured to the motor shaft) and a movable flange side that can be rotated around the fixed flange side that increases or reduces the pitch diameter of this driver pulley. (See Fig. 7.)

As the pitch diameter is changed by adjusting the position of the movable flange, the centerline on this pulley shifts laterally, along the motor shaft. This creates a requirement for a realignment of the pulleys after any adjustment of the movable flange. Also reset the belt tension after each realignment. The factory settings of the adjustable pulley is five turns open from full closed.

Check the condition of the motor pulley for signs of wear. Glazing of the belt contact surfaces and erosion on these surfaces are signs of improper belt tension and/or belt slippage. Pulley replacement may be necessary.

Changing Fan Speed

1. Shut off the main unit power supply, and use the approved lockout/tag-out procedures.
2. Loosen the belt by loosening the motor adjustment bolts as described in the Belt Adjustment section.
3. Loosen the movable pulley flange setscrew. (See Fig. 7.)
4. Screw the movable flange toward fixed flange to increase speed and away from fixed flange to decrease speed.

Increasing fan speed increases load on the motor. Do not exceed maximum speed specified in the Product Data or motor amperage listed on the unit rating plate.

5. Set the movable flange at the nearest keyway or flat of the pulley hub and tighten the setscrew to torque of 72 ± 5 in.-lb (8.14 ± 0.56 Nm).

Aligning the Fan and Motor Pulleys

1. Loosen the fan pulley setscrews.
2. Slide the fan pulley along the fan shaft. Make angular alignment by loosening the motor from its mounting. See Fig. 8.
3. Tighten the fan pulley setscrews and motor mounting bolts to torque specifications.
4. Recheck the belt tension. See Fig. 6.

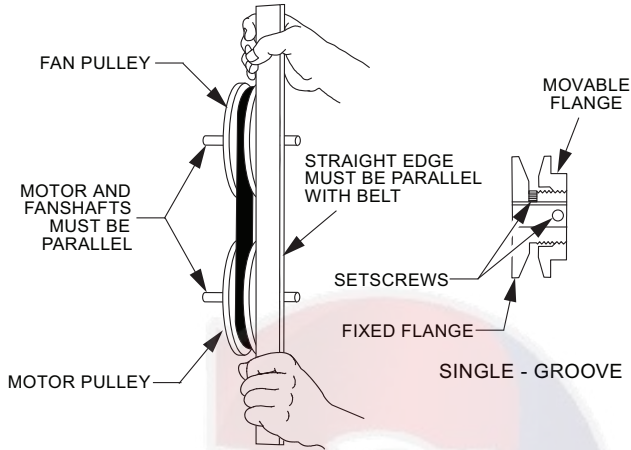

Fig. 8 — Supply-Fan Pulley Adjustment

BEARINGS

This fan system uses bearings featuring concentric split locking collars. The collars are tightened through a cap screw bridging the split portion of the collar. The cap screw has a Torx T25 socket head. To tighten the locking collar: Hold the locking collar tightly against the inner race of the bearing and torque the cap screw to 65 to 70 in.-lb. (7.4 to 7.9 Nm). See Fig. 9.

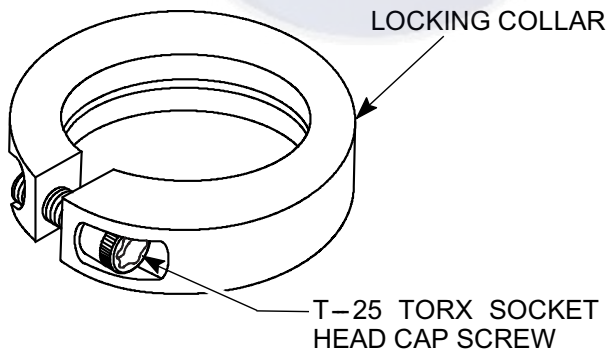

Fig. 9 — Tightening Locking Collar

STAGED AIR VOLUME (SAV) CONTROL: 2-SPEED FAN WITH VARIABLE FREQUENCY DRIVE (VFD)

Staged Air Volume (SAV) Indoor Fan Speed System

NOTE: The SAV option is not available on units with Humidi-MiZer adaptive humidification system.

The SAV system utilizes a fan speed control board and Variable Frequency Drive (VFD) to automatically adjust the indoor fan motor speed in sequence with the unit's ventilation, cooling and

heating operation. Conforming to ASHRAE 90.1 2010 Standard Section 6.4.3.10.b, during the first stage of cooling operation the SAV system will adjust the fan motor to provide 66% of the design airflow rate for the unit. When the call for the second stage of cooling is required, the SAV system will allow the design airflow rate for the unit established (100%). During the heating mode, the SAV system will allow total design airflow rate (100%) operation. During ventilation mode, the SAV system will operate the fan motor at 66% speed.

Identifying Factory Option

This section only applies to units that meet the criteria detailed in Table 1. See Appendix A for the model number nomenclature breakdown.

Table 1 — Model-Size / VFD Option Indicator

UNIT	POSITION IN MODEL NUMBER	VDP FIOP INDICATOR
50TC 17-30	17	G, J

Unit Installation with SAV Option

50TC ROOFTOP

Refer to the base unit installation instructions for standard required operating and service clearances.

NOTE: The Remote VFD Keypad is a field-installed option. It is not included as part of the factory-installed VFD option. See "Variable Frequency Drive (VFD) Installation, Setup and Troubleshooting Supplement" for wiring schematics and performance charts and configuration. See Fig. 10 for location of the VFD as mounted on the various 50TC models.

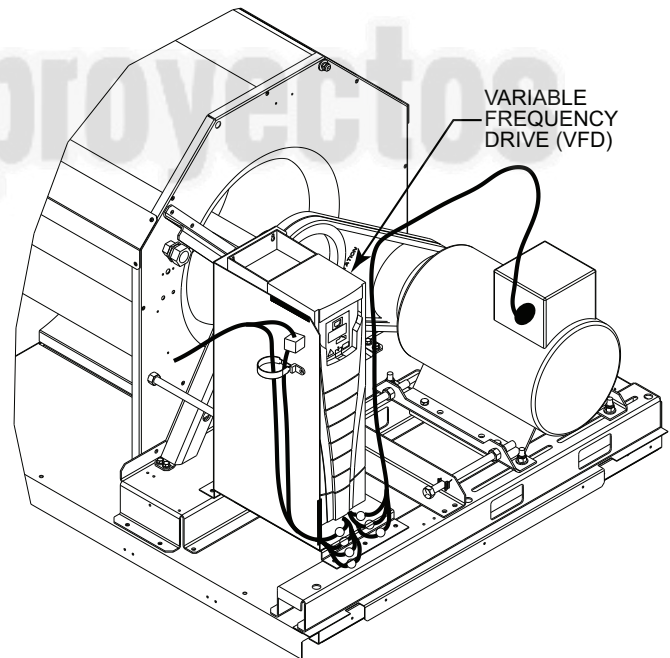

Fig. 10 — VFD Location for 50TC 15-27.5 Units

ADDITIONAL VFD INSTALLATION AND TROUBLESHOOTING

Additional installation, wiring and troubleshooting information for the VFD can be found in the following manuals: "Variable Frequency Drive (VFD) Installation, Setup and Troubleshooting Supplement."

MOTOR

When replacing the motor, use the following steps. See Fig. 11.

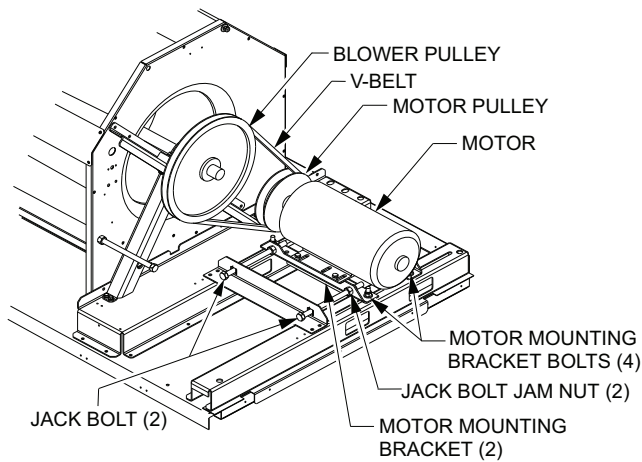

Fig. 11 — Replacing Belt Driven Motor

Replacing the Motor

1. Turn off all electrical power to the unit. Use approved lock-out/tag-out procedures on all electrical power sources.
2. Remove the cover on the motor connection box.
3. Disconnect all electrical leads to the motor.
4. Loosen the two jack bolt jamnuts on the motor mounting bracket.
5. Turn the two jack bolts counterclockwise until the motor assembly moves closer to the blower pulley.
6. Remove the V-belt from the blower pulley and motor pulley.

CAUTION

EQUIPMENT DAMAGE HAZARD

Failure to follow this CAUTION can result in premature wear and damage to equipment.

Do not use a screwdriver or a pry bar to place the new V-belt in the pulley groove. This can cause stress on the V-belt and the pulley resulting in premature wear on the V-belt and damage to the pulley.

7. Loosen the four mounting bracket bolts and lock washers.
8. Remove four bolts, four flat washers, four lock washers and four nuts attaching the motor mounting plate to the unit. Discard all lock washers.
9. Remove the motor and motor mounting bracket from the unit.
10. Remove four bolts, flat washers, lock washers and single external-tooth lock washer attaching the motor to the motor mounting plate. Discard all lock washers and external-tooth lock washer.
11. Lift the motor from the motor mounting plate and set aside.
12. Slide the motor mounting band from the old motor.
13. Slide the motor mounting band onto the new motor and set the motor onto the motor mounting plate.
14. Remove the variable pitch pulley from the old motor and attach it to the new motor.
15. Inspect the variable pitch pulley for cracks and wear. Replace the pulley if necessary.
16. Secure the pulley to the motor by tightening the pulley set-screw to the motor shaft.
17. Insert four bolts and flat washers through the mounting holes on the motor and into holes on the motor mounting plate.

18. On one bolt, place a new external-tooth lock washer between the motor and motor mounting band.
19. Make sure the teeth of the external-tooth lock washer make contact with the painted base of the motor. This washer is essential for properly grounding the motor.
20. Install four new lock washers and four nuts on the bolts on the bottom of the motor mounting plate, but do not tighten the mounting bolts at this time.
21. Set the new motor and motor mounting bracket back onto the unit. See Fig. 11.
22. Install four bolts, four flat washers, four new lock washers and four nuts attaching the motor assembly to the unit, but do not tighten the mounting bolts at this time.
23. Install the motor drive V-belt to the motor pulley and blower wheel pulley. See CAUTION.
24. Align the motor pulley and blower wheel pulley using a straight edge. See Fig. 8.
25. Adjust the V-belt tension using the adjustment tool.
26. Turn the two jack bolts clockwise, moving the motor assembly away from the blower pulley, increasing the V-belt tension.
27. Tighten the four bolts securing the motor mounting brackets to the unit. Torque bolts to 120 ± 12 in.-lb (14 ± 1.4 Nm).
28. Remove the cover on the motor connection box.
29. Re-connect all electrical leads to the motor and replace the connection box cover.
30. Re-connect all electrical power to the unit. Remove lockout tags on all electrical power sources.
31. Start the unit and allow to run for a designated period.
32. Shut off the unit and make any necessary adjustments to the V-belt tension or the motor and blower wheel pulley alignment.

Changing Fan Wheel Speed by Changing Pulleys

The horsepower rating of the belt is primarily dictated by the pitch diameter of the smaller pulley in the drive system (typically the motor pulley in these units). Do not install a replacement motor pulley with a smaller pitch diameter than provided on the original factory pulley. Change fan wheel speed by changing the fixed fan pulley (larger pitch diameter to reduce wheel speed, smaller pitch diameter to increase wheel speed) or select a new system with both pulleys and matching belt(s).

Before changing pulleys to increase fan wheel speed, check the fan performance at the target speed and airflow rate to determine new motor loading (bhp). Use the fan performance tables or use the Packaged Rooftop Builder software program. Confirm that the motor in this unit is capable of operating at the new operating condition. Fan shaft loading increases dramatically as wheel speed is increased.

CAUTION

EQUIPMENT DAMAGE HAZARD

Failure to follow this caution can result in equipment damage. Drive packages cannot be changed in the field. For example: a standard drive cannot be changed to a high static drive. This type of change will alter the unit's certification and could require heavier wiring to support the higher amperage draw of the drive package.

To reduce vibration, replace the motor's adjustable pitch pulley with a fixed pitch pulley (after the final airflow balance adjustment). This will reduce the amount of vibration generated by the motor/belt-drive system.

To determine variable pitch pulley diameter, perform the following calculation:

1. Determine full open and full closed pulley diameter.
2. Subtract the full open diameter from the full closed diameter.
3. Divide that number by the number of pulley turns open from full closed.

This number is the change in pitch datum per turn open.

EXAMPLE:

- Pulley dimensions 2.9 to 3.9 (full close to full open)
- $3.9 - 2.9 = 1\text{-in.}$
- 1 divided by 5 (turns from full close to full open)
- 0.2 change in pulley diameter per turn open
- $2.9 + 0.2 = 3.1$ pulley diameter when pulley closed one turn from full open.

CONDENSER COIL SERVICE

Round Tube Plate Fin (RTPF) Condenser Coil

The condenser coil is fabricated with round tube copper hairpins and plate fins of various materials and/or coatings (see the model number nomenclature in Appendix A to identify the materials provided in this unit). The coil may be one-row or composite-type two-row. Composite two-row coils are two single-row coils fabricated with a single return bend end tubesheet.

Recommended Condenser Coil Maintenance and Cleaning

Routine cleaning of coil surfaces is essential to maintain proper operation of the unit. Elimination of contamination and removal of harmful residues will greatly increase the life of the coil and extend the life of the unit. The following maintenance and cleaning procedures are recommended as part of the routine maintenance activities to extend the life of the coil.

REMOVE SURFACE LOADED FIBERS

Surface loaded fibers or dirt should be removed with a vacuum cleaner. If a vacuum cleaner is not available, a soft non-metallic bristle brush may be used. In either case, the tool should be applied in the direction of the fins. Coil surfaces can be easily damaged (fin edges can be easily bent over and damage to the coating of a protected coil) if the tool is applied across the fins.

NOTE: Use of a water stream, such as a garden hose, against a surface loaded coil will drive the fibers and dirt into the coil. This will make cleaning efforts more difficult. Surface loaded fibers must be completely removed prior to using low-velocity clean water rinse.

PERIODIC CLEAN WATER RINSE

A periodic clean water rinse is very beneficial for coils that are applied in coastal or industrial environments. However, it is very important that the water rinse is made with a very low-velocity water stream to avoid damaging the fin edges. Monthly cleaning as described is recommended.

ROUTINE CLEANING OF COIL SURFACES

Periodic cleaning with Totaline® environmentally sound coil cleaner is essential to extend the life of coils. This cleaner is available from Carrier Replacement Components Division as P/N: P902-0301 for a one-gallon (3.8L) container, and P902-0305 for a 5-gallon (18.9L) container. It is recommended that all coils, including standard aluminum, pre-coated, copper/copper or E-coated coils be cleaned with the Totaline environmentally sound coil cleaner as described below.

Coil cleaning should be part of the unit's regularly scheduled maintenance procedures to ensure long life of the coil. Failure to clean the coils may result in reduced durability in the environment.

Avoid use of:

- coil brighteners
- acid cleaning prior to painting
- high pressure washers
- poor quality water for cleaning

Totaline environmentally sound coil cleaner is a nonflammable, hypoallergenic, non bacterial, USDA accepted biodegradable agent that will not harm the coil or surrounding components such as electrical wiring, painted metal surfaces, or insulation. Use of non-recommended coil cleaners is strongly discouraged since coil and unit durability could be affected.

Two-Row Coils

Clean coil as follows:

1. Turn off unit power and tag the disconnect.
2. Remove the top panel screws on the condenser end of the unit.
3. Remove the condenser coil corner post. See Fig. 12.
4. Lift and hold the top cover open.
5. Hold the top pan open by placing the coil corner post between the top panel and center post. See Fig. 13.
6. Remove the screws securing the coil to the compressor plate and compressor access panel.
7. Remove the fasteners holding the coil sections together at the return end of the condenser coil. Carefully separate the outer coil section 3 to 4 in. from the inner coil section. See Fig. 14.
8. Clean the outer surfaces with a stiff brush in the normal manner. Use a water hose or other suitable equipment to flush down between the 2 coil sections to remove dirt and debris.
9. Secure the inner and outer coil rows together with a field-supplied fastener.
10. Reposition the outer coil section and remove the coil corner post from between the top panel and center post. Reinstall the coil corner post and access panel.
11. Replace all screws.

CAUTION

UNIT DAMAGE HAZARD

Failure to follow this caution can result in reduced unit performance or unit shutdown.

Use only the recommended approved cleaning procedures for proper system performance.

EVAPORATOR COILS

The evaporator coil uses the traditional round-tube, plate-fin (RTPF) technology. Tube and fin construction consists of various optional materials and coatings (see Appendix A). Coils are multiple-row. On two-compressor units, the evaporator coil is a face split design, meaning the two refrigerant circuits are independent in the coil. The bottom portion of the coil will always be circuit A, with the top of the coil being circuit B.

Coil Maintenance and Cleaning Recommendation

Routine cleaning of coil surfaces is essential to maintain proper operation of the unit. Elimination of contamination and removal of harmful residues will greatly increase the life of the coil and extend the life of the unit. The following maintenance and cleaning procedures are recommended as part of the routine maintenance activities to extend the life of the coil.

REMOVING SURFACE LOADED FIBERS

Surface loaded fibers or dirt should be removed with a vacuum cleaner. If a vacuum cleaner is not available, a soft non-metallic bristle brush can be used. In either case, the tool should be applied in the direction of the fins. Coil surfaces can be easily damaged. Applying the tool across the fin edges can cause the edges to be easily bent over, damaging the coating of a protected coil.

NOTE: Use of a water stream, such as a garden hose, against a surface-loaded coil will drive the fibers and dirt into the coil. This will make cleaning efforts more difficult. Surface-loaded fibers must be completely removed prior to using a low-velocity clean water rinse. A vacuum cleaner or a soft-bristled brush should be used to remove surface-loaded fibers and dirt.

PERIODIC CLEAN WATER RINSE

A periodic clean-water rinse is very beneficial for coils that are used in coastal or industrial environments. However, it is very important that the water rinse is made with a very low-velocity water stream to avoid damage to the fin edges. Monthly cleaning, as described below, is recommended.

ROUTINE CLEANING OF EVAPORATOR COIL SURFACES

Monthly cleaning with Totaline environmentally sound coil cleaner is essential to extend the life of the coils. This cleaner is available from Carrier Replacement Parts Division (P/N: P902-0301 for a one-gallon (3.8L) container, and P/N: P902-0305 for a 5-gallon (18.9L) container). It is recommended that all round tube coils be cleaned as described below. Coil cleaning should be part of the unit's regularly scheduled maintenance procedures to ensure a long life for the coil. Failure to clean the coils can result in reduced durability in the environment. When cleaning the coils, avoid use of the following:

- coil brighteners
- acid cleaning prior to painting
- high pressure washers
- poor quality water for cleaning

Totaline environmentally sound coil cleaner is a nonflammable, hypoallergenic, non bacterial, USDA accepted biodegradable agent that will not harm the coil or surrounding components such as electrical wiring, painted metal surfaces, or insulation. Use of non-recommended coil cleaners is strongly discouraged since coil and unit durability could be affected.

Totaline Environmentally Sound Coil Cleaner Application Equipment

- 2½ gallon garden sprayer
- Water rinse with low velocity spray nozzle

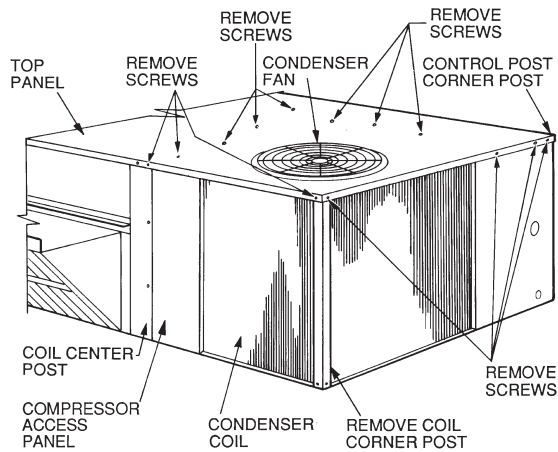

Fig. 12 — Cleaning Condenser Coil

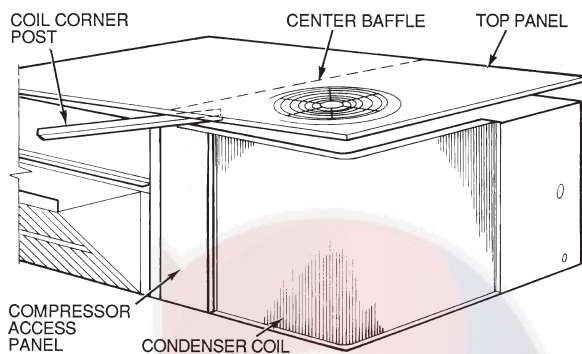

Fig. 13 — Propping Up Top Panel

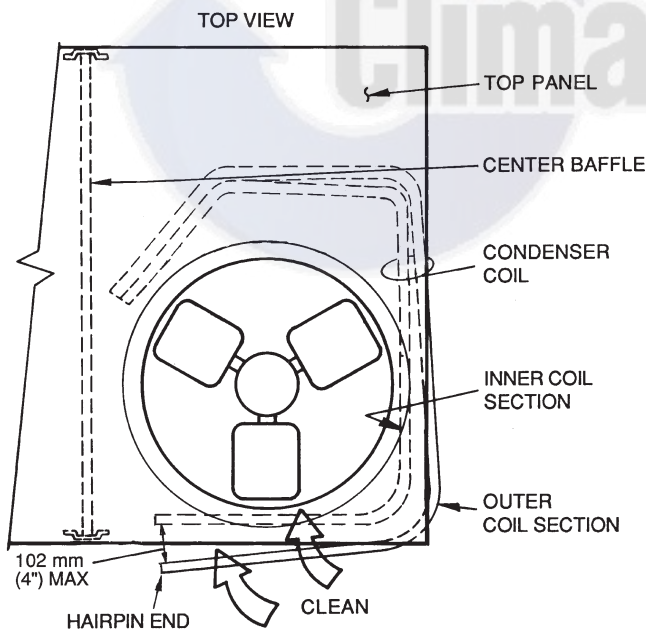

Fig. 14 — Separating Coil Sections

⚠ CAUTION

PERSONAL INJURY HAZARD

Failure to follow this caution can result in severe personal injury and reduced unit performance.

High velocity water from a pressure washer, garden hose, or compressed air should never be used to clean a coil. The force of the water or air jet will bend the fin edges and increase air-side pressure drop.

High velocity water from a pressure washer can cause severe injury upon contact with exposed bodily tissue. Always direct the water stream away from the body.

Totaline Environmentally Sound Coil Cleaner Application Instructions

1. Proper protection such as safety glasses, gloves and protective clothing are recommended during mixing and application.

⚠ CAUTION

UNIT DAMAGE HAZARD

Failure to follow this caution may result in accelerated corrosion of unit parts.

Harsh chemicals, household bleach or acid or basic cleaners should not be used to clean outdoor or indoor coils of any kind. These cleaners can be very difficult to rinse out of the coil and can accelerate corrosion at the fin/tube interface where dissimilar materials are in contact. If there is dirt below the surface of the coil, use the environmentally balanced coil cleaner.

2. Remove all surface loaded fibers and dirt with a vacuum cleaner as described above.
3. Thoroughly wet finned surfaces with clean water and a low velocity garden hose, being careful not to bend fins.
4. Mix Totaline environmentally sound coil cleaner in a 2½ gallon (9.6 L) garden sprayer according to the instructions included with the cleaner. The optimum solution temperature is 100°F (38°C).

NOTE: Do NOT USE water in excess of 130°F (54°C), as the enzymatic activity will be destroyed.

5. Thoroughly apply Totaline environmentally sound coil cleaner solution to all coil surfaces, including finned area, tube sheets and coil headers.
6. Hold the garden sprayer nozzle close to finned areas and apply cleaner with a vertical, up-and-down motion.
7. Avoid spraying in a horizontal pattern to minimize potential for fin damage.
8. Make sure the cleaner thoroughly penetrates deep into the finned areas.

9. Interior and exterior finned areas must be thoroughly cleaned.
10. Finned surfaces should remain wet with cleaning solution for 10 minutes.
11. Make sure surfaces are not allowed to dry before rinsing. Reapply cleaner as needed to ensure 10 minute saturation is achieved.
12. Thoroughly rinse all surfaces with low-velocity clean water using a downward rinsing motion of the spray nozzle. Protect fins from damage from the spray nozzle.

EVAPORATOR COIL METERING DEVICES

The metering devices are multiple fixed-bore devices (Acutrol) swedged into the horizontal outlet tubes from the liquid header, located at the entrance to each evaporator coil circuit path. These are non-adjustable. Service requires replacing the entire liquid header assembly.

To check for possible blockage of one or more of these metering devices, disconnect the supply fan contactor (IFC) coil, then start the compressor and observe the frosting pattern on the face of the evaporator coil. A frost pattern should develop uniformly across the face of the coil starting at each horizontal header tube. Failure to develop frost at an outlet tube can indicate a plugged or a missing orifice.

Refrigerant System Pressure Access Ports

There are two access ports in the system - on the suction tube near the compressor and on the discharge tube near the compressor. These are brass fittings with black plastic caps. The hose connection fittings are standard ¼-in. SAE male flare couplings.

The brass fittings are two-piece High Flow valves, with a receptacle base brazed to the tubing and an integral spring-closed check valve core screwed into the base (see Fig. 15). This schrader valve is permanently assembled into this core body and cannot be serviced separately; replace the entire core body if necessary. Service tools are available from RCD (P/N P920-0010) that allow the replacement of the schrader valve core without having to recover the entire system refrigerant charge. Apply compressor refrigerant oil to the schrader valve core's bottom o-ring. Install the fitting body with 96 ± 10 in.-lb (10.85 ± 1.13 Nm) of torque; do not overtighten.

NOTE: The High-Flow valve has a black plastic cap with a rubber o-ring located inside the cap. This rubber o-ring must be in place in the cap to prevent refrigerant leaks.

EXAMPLE:

Model 50TC*D28

Circuit A (from Fig. 15)

Outdoor Temperature 85°F (29°C)

Suction Pressure 125 psig (860 kPa)

Suction Temperature should be 63°F (17°C)

Circuit B (from Fig. 15)

Outdoor Temperature 85°F (29°C)

Suction Pressure 120 psig (830 kPa)

Suction Temperature should be 58°F (14°C)

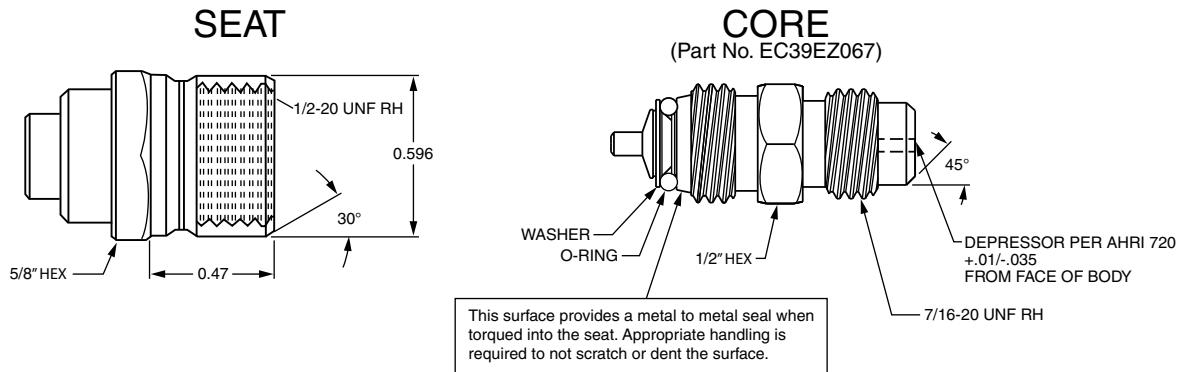

Fig. 15 — CoreMax¹ Access Port Assembly

HUMIDI-MIZER® ADAPTIVE DEHUMIDIFICATION SYSTEM

Units with the factory-equipped Humidi-MiZer option are capable of providing multiple modes of improved dehumidification as a variation of the normal cooling cycle. See Fig 18. The design of the Humidi-MiZer system allows for two humidity control modes of operation of the rooftop unit, utilizing a common subcooling/reheat dehumidification coil located downstream of the standard evaporator coil. This allows the rooftop unit to operate in both a dehumidification (Subcooling) mode and a hot gas (Reheat) mode for maximum system flexibility. The Humidi-MiZer package is factory-installed and will operate whenever there is a dehumidification requirement present.

The Humidi-MiZer system is initiated based on an input from a discrete input from a mechanical space or return air humidistat.

Humidi-MiZer System Components

The Humidi-MiZer System uses the standard unit compressor(s), evaporator coil and Round Tube-Plate Fin (RTPF) condenser coil. Additional refrigeration system hardware includes a subcooler/reheat coil and control solenoid valves. On some models, the evaporator coil includes a TXV as a standard feature. Units with Humidi-MiZer FIOP also include a factory-installed head pressure control system (Motormaster I) to provide proper liquid pressure during reheat modes. Unique system controls include a reheat relay mode, and evaporator coil freeze stat, and secondary low pressure switch. See Fig. 16. See Fig. 17 and Table 2 (on page 14) for Reheat Control input/output (I/O) connections.

SUBCOOLER/REHEAT COIL

The Subcooler/Reheat Coil is mounted across the leaving face of the unit's evaporator coil. The coil is a one-row design with two separate circuits.

- 3-Way Solenoid Valve
- Hot Gas Bypass Solenoid Valve
- Relay Reheat Board (RHB)
- Evaporator Freeze Protection Thermostat
- Low Outdoor Temperature Lockout Switch
- Secondary Low Pressure Switch
- Head Pressure Control

Operating Sequences

The Humidi-MiZer system provides three sub-modes of operation: Normal Cooling (see Fig. 18), Subcooling Reheat¹ (see Fig. 19) and Hot Gas Reheat² (see Fig. 20).

The Reheat¹ and Reheat² modes are available when the unit is not in a heating mode and when the Low Ambient Lockout Switch is closed.

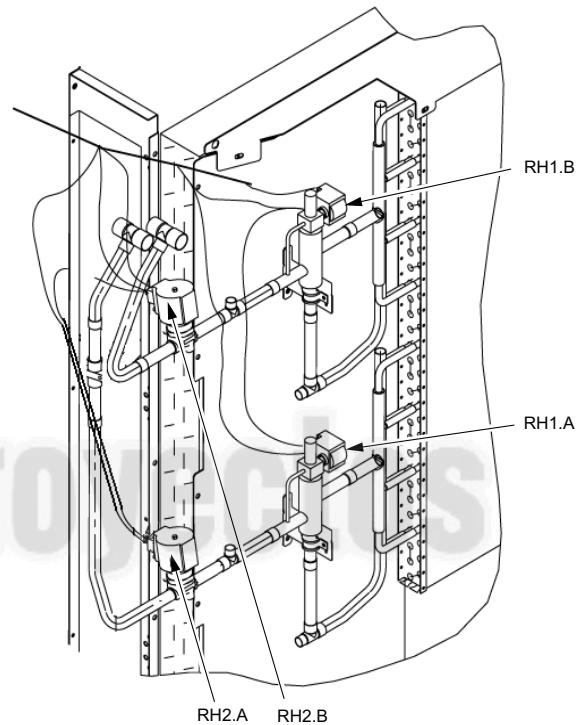

Fig. 16 — Humidi-MiZer Valve Locations

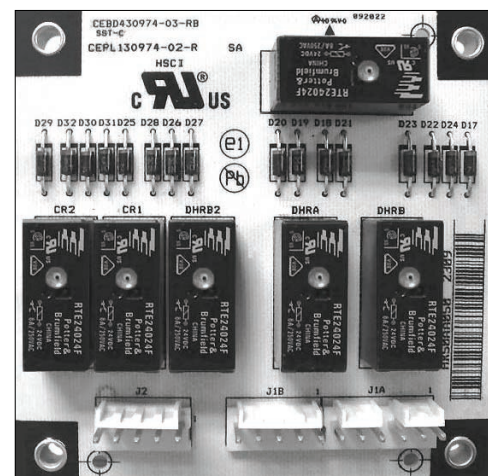

Fig. 17 — Reheat Control Board (RCB)

1. CoreMax is a registered trademark of Fastest, Inc.

When there is only a single cooling demand (thermostat Y1 alone or with thermostat Y2), one or both circuits will operate in Reheat2 mode. Both solenoids are energized in both circuits. See Fig. 20, Hot Gas Reheat Schematic for system refrigerant flow.

When there is both cooling demand (thermostat Y1 demand) and dehumidification demand, circuit 1 will operate in Reheat1 mode (Subcooling, Fig. 19) and circuit will operated in Reheat2 mode (Reheat, Fig. 20). In Reheat1 mode, the 3-way solenoid valve is energized, opening the reheat coil to the refrigeration flow path providing sub-cooling to the liquid before it enters the TXV. See Table 3 for further details on Humidi-MiZer system operating modes. See Table 4 for details on troubleshooting the Humidi-MiZer system.

Humidi-MiZer Modes

NORMAL COOLING

During the Normal Cooling mode, the liquid refrigerant flows from the outdoor condenser through the normally open (NO) Cooling System Valve (CSV) to the expansion device. Both the Reheat1 (RH1.x) and Reheat2 (RH2) valves are closed during the normal cooling mode.

During the Normal Cooling mode, the refrigerant flows from the outdoor compressor through the condenser coil. The Reheat2 (RH2.x) is closed, preventing the refrigerant from bypassing the condenser coil. The refrigerant then flows through the open Reheat1 (RH1.x) 3-way valve to the TXV Metering Device, bypassing the Humidi-MiZer coil, and finally passing through the evaporator coil before returning to the outdoor compressor. See Fig 18.

REHEAT1 (SUBCOOLING MODE)

The Reheat1 or Subcooling mode will be engaged to satisfy part-load-type conditions when there is a space call for cooling and dehumidification. Although the temperature could have dropped and decreased the sensible load in the space, the outdoor and/or space humidity levels could have risen. A typical scenario could be when the outside air is 85°F (29°C) with 70% to 80% relative humidity (RH). Desired Sensible Heat Ratio (SHR) for equipment in this scenario is typically from 0.4 to 0.7. The Humidi-MiZer unit will initiate the Dehumidification mode when both the space temperature and humidity are above the temperature and humidity setpoints while attempting to meet both setpoint requirements.

Once the humidity requirement is met, the unit can continue to operate in normal cooling mode to meet any remaining sensible capacity load. Alternatively, if the sensible load is met and humidity levels remain high, the unit can switch to Hot Gas Reheat mode or Reheat2 mode to provide neutral, dehumidified air.

During the Reheat1 or Subcooling mode, the liquid refrigerant flows from the outdoor compressor through the condenser coil to the Reheat1 (RH1.x) 3-way valve and on to the Humidi-Mizer coil. The Reheat2 (RH2.x) valve is closed. The liquid refrigerant then passes through the Humidi-Mizer coil and then a metering device or Thermostatic Expansion Valve (TXV). From the TXV, the liquid refrigerant passes through the evaporator coil and back to the outdoor compressor. See Fig 19.

REHEAT2 (HOT GAS REHEAT MODE)

This Reheat2 or Hot Gas Reheat mode is used when dehumidification is required without a need for cooling, such as when the outside air is at a neutral temperature, but high humidity exists. This situation requires the equipment to operate at a low SHR of 0.0 to 0.2. With no cooling requirement calling for dehumidification, the Humidi-MiZer adaptive dehumidification system will energize both compressors, opening the two hot gas bypass valves, allowing refrigerant flow to the Humidi-MiZer coil to reheat the unit's supply air to a neutral temperature.

The hot bypassed refrigerant liquid (gas or two-phase mixture) exits the outdoor compressor and passes through the open Reheat1 (RH1.x) at the same time it passes through the condenser coil to the open Reheat2 (Rh2.x) to the Humidi-MiZer coil. After the refrigerant passes through the Humidi-MiZer coil, it enters a TXV metering device, decreasing the air pressure, and on to the evaporator coil. The refrigerant is subcooled in this coil to a temperature approaching the evaporator leaving air temperature. The liquid refrigerant then returns to the outdoor compressor. See Fig. 20.

The refrigerant enters the TXV and evaporator coil at a temperature lower than the temperature in the standard cooling operation. This lower temperature increases the latent capacity of the evaporator. The refrigerant passes through the evaporator turning it into a superheated vapor. The air passing over the evaporator coil becomes colder than it would during normal operation. As this same air passes over the Humidi-MiZer Reheat Coil, it will be warmed to the neutral supply air temperature.

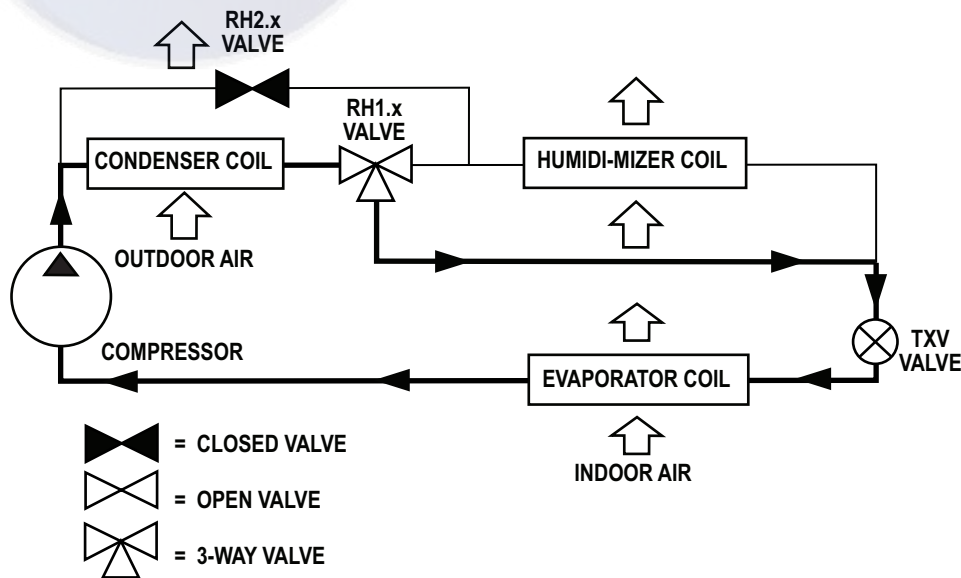

Fig. 18 — Normal Cooling Mode – Humidi-MiZer System

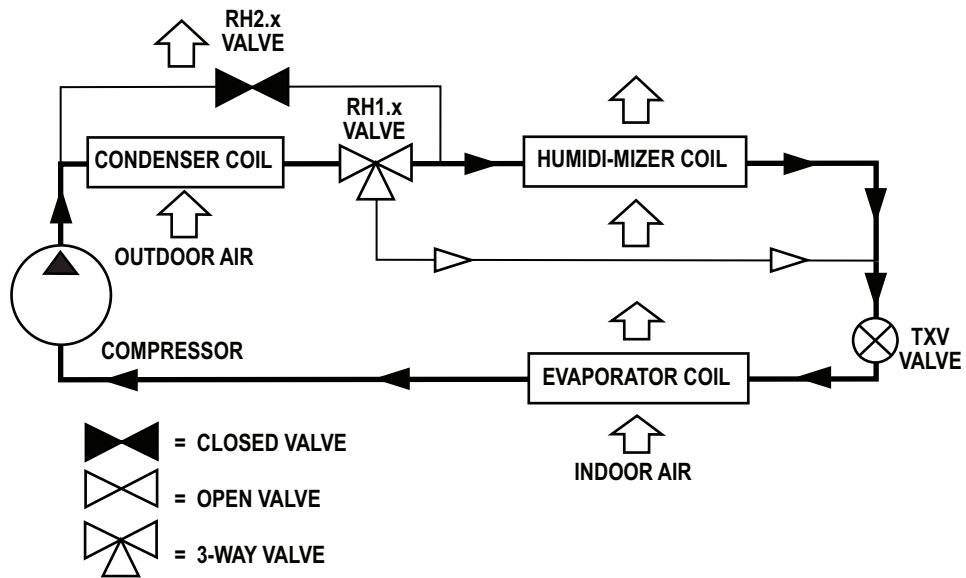

Fig. 19 — Subcooling Mode (Reheat 1) – Humidi-MiZer System

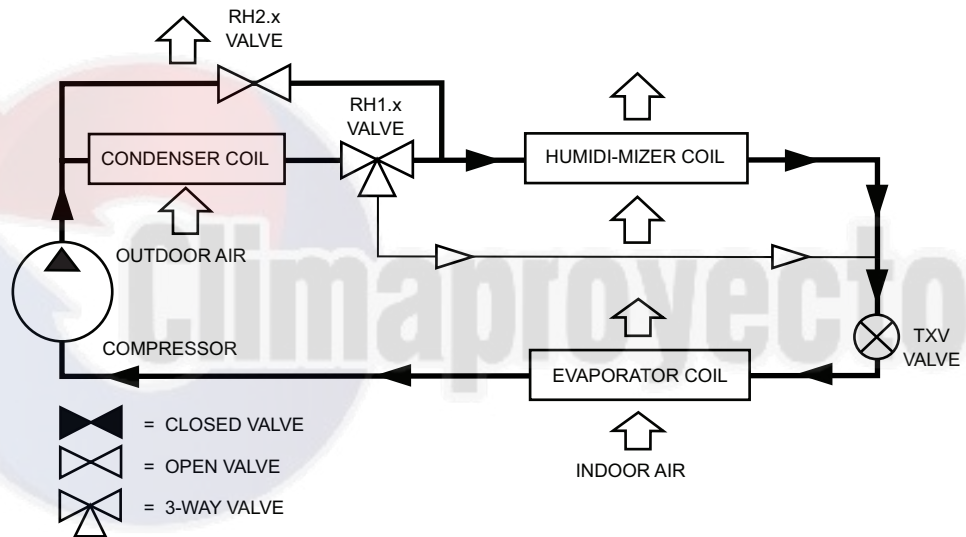

Fig. 20 — Hot Gas Reheat Mode (Reheat 2) – Humidi-MiZer System

Table 2 — Humidi-MiZer Reheat Control Board I/O

POINT NAME	TYPE	CONNECTION PIN NUMBER	UNIT CONNECTION	NOTE
Humidistat/LTLO	DI, 24VAC	J1A - 1 (1)	LTLO	
Thermostat W1	DI, 24VAC	J1A - 2 (2)	CTB - REHEAT - 4	
Econ Y1	DI, 24VAC	J1A - 6 (6)	CTB - REHEAT - 5	
Thermostat G	DI, 24VAC	J1B - 1 (7)	CTB - REHEAT - 1	
24V Power (J1)	24VAC	J1B - 3 (9)	CTB - R	
24V Power (J2)	24 VAC J2 - 1	CTB - R		
Econ Y2	DI, 24VAC	J1B - 5 (11)	CTB - REHEAT - 7	2 - circ only
COMP1	DO, 24VAC	J1A - 5 (5)	CTB - HEAT - 6	
IFM	DO, 24VAC	J1B - 4 (8)	CTB - REHEAT - 2	
COMP2	DO, 24VAC	J1B - 4 (10)	CTB - REHEAT - 8	
LSV	DO, 24VAC	J2 - 2	FTP (BLK)	
DSV1	DO, 24VAC	J2 - 3	DSV	
NOT LSV	DO, 24VAC	J2 - 4		2 - circ only
DSV2	DO, 24VAC	J2 - 5		2 - circ only

LEGEND

- COMP** — Compressor
- CTB** — Control Terminal Board
- DI** — Discrete Input (switch)
- DO** — Discrete Output (switch)
- DSV** — Discharge (gas) Solenoid Valve
- ECON** — Economizer
- FPT** — Freeze Protection Thermostat
- IFM** — Indoor (supply) Fan Motor
- LSV** — Liquid Solenoid Valve
- LTLO** — Low Temperature Lockout
- REHEAT** — Connection Strip REHEAT (on CTB)

Table 3 — Inputs/Modes/Outputs Summary

INPUT					MODE		OUTPUT							
Y1	Y2	W1	G	HUM/LTLO			COMP 1	COMP 2	IFM	LSV1	LSV2	LSV NOT	DSV1	DSV2
OFF	OFF	OFF	ON	OFF	Normal	Fan	OFF	OFF	ON=G	OFF	OFF	ON=R	OFF	OFF
ON	OFF	OFF	On	OFF	Normal	Cool1	ON=Y1	OFF	ON=G	OFF	OFF	ON=R	OFF	OFF
ON	ON	OFF	ON	OFF	Normal	Cool2	ON=Y2	ON	ON=G	OFF	OFF	ON=R	OFF	OFF
OFF	OFF	ON	X	OFF	Normal	Heat 1	OFF	OFF	ON=G	OFF	OFF	ON=R	OFF	OFF
OFF	OFF	OFF	ON	ON	Reheat	Dehumidify	ON	ON	ON=G	ON	ON	OFF	ON=R	ON=R
ON	OFF	OFF	ON	ON	Subcool Cir1/ Reheat Cir2	Cool1 and Cool2 / Subcool-Dehumidify	ON	ON	ON=G	ON	ON	OFF	OFF	ON=R
ON	ON	OFF	ON	ON	Subcool Cir1 and Cir2	Cool1 and Cool2 / Subcool-Dehumidify	ON	ON	ON=G	ON	ON	OFF	OFF	OFF
OFF	OFF	ON	X	ON	Heat Override	Heat 1	OFF	OFF	ON=G	OFF	OFF	ON=R	OFF	OFF
OFF	OFF	ON+ W2	X	ON	Heat Override	Heat 1 and 2	OFF	OFF	ON=G	OFF	OFF	ON=R	OFF	OFF

Table 4 — Humidi-MiZer Troubleshooting

PROBLEM	CAUSE	REMEDY
Subcooling Reheat Mode Will Not Activate	General cooling mode problem	See Cooling Service Troubleshooting (Table 5).
	No dehumidification demand	See No Dehumidification Demand, below.
	CRC relay operation	See CRC Relay Operation, below.
	Circuit RLV, CLV or LDV valve problem	See CLV, RLV or LDV Valve Operation, below.
Hot Gas Reheat Mode Will Not Activate	General cooling mode problem	See Cooling Service Troubleshooting (Table 5).
	No dehumidification demand	See No Dehumidification Demand, below.
	CRC relay operation	See CRC Relay Operation, below.
	Circuit RLV, CLV or LDV valve problem	See CLV, RLV or LDV Valve Operation, below.
	Circuit RDV valve is not open	See RDV Valve Operation, below.
No Dehumidification Demand	Outdoor temperature too low	Check the LTLO is functioning properly.
	Relative humidity setpoint too low — Humidistat	Check/reduce setting on accessory humidistat.
	Relative humidity setpoint too low — RH sensor	On units with DDC, verify the RH sensor is reading properly and that the setpoint is set properly.
CRC Relay Operation	No humidity signal	Check wiring. Check humidistat or humidity sensor.
	No 24V signal to input terminals	Check the dedicated Humidi-MiZer transformer for voltage or tripped circuit breaker. Check wiring. Check transformer and circuit breaker.
	No power to output terminals	Check wiring.
RLV, CLV or LDV Valve Operation	Relay outputs do not change state	Replace faulty relay.
	No 24V signal to input terminals	Check CRC Relay Operation. Check Wiring. Check transformer and circuit breaker or fuses.
	Solenoid coil burnout	Check continuous over-voltage is less than 10%.
		Check under-voltage is less than 15%.
		Check for missing coil assembly parts. Check for damaged valve enclosing tube.
Stuck valve	Replace valve. Replace filter drier.	
RDV Valve Operation (NOTE: Normally Closed When De-energized)	No 24V signal to input terminals	Check RDV relay operation. Check wiring. Check transformer and circuit breaker or fuses.
	Solenoid coil burnout	Check continuous over-voltage is less than 10%.
		Check under-voltage is less than 15%.
		Check for missing coil assembly parts. Check for damaged valve enclosing tube.
	Stuck valve	Replace valve. Replace filter drier.
Low Latent Capacity in Subcooling or Hot Gas Reheat Modes	CLV valve open or leaking	See CLV Valve Operation, above.
Low Sensible Capacity in Normal Cool or Subcooling Reheat Modes	RDV valve open or leaking	See RDV Valve Operation, above.
Low Suction Pressure and High Superheat During Normal Cool Mode	General cooling mode problem	See Cooling Service Troubleshooting (Table 5).
	RDV valve open or leaking	See RDV Valve Operation, above.
Low Suction Pressure and High Discharge Pressure	General cooling mode problem	See Cooling Service Troubleshooting (Table 5).
	Both RLV and CLV valves closed	See RLV and CLV Valve Operation, above.
RDV Valve Cycling On/Off	Hot Gas Reheat mode low suction pressure limit	Normal Operation During Mixed Circuit Subcooling and Hot Gas Reheat Modes at Lower Outdoor Temperatures.
Circuit B Will Not Operate With Circuit A Off	Normal operation. Motormaster outdoor fan control requires operation of circuit A.	None

LEGEND

- CRC** — Cooling/Reheat Control
- CLV** — Cooling Liquid Valve
- RLV** — Reheat Liquid Valve
- RH** — Relative Humidity
- RDV** — Reheat Discharge Valve

THERMOSTATIC EXPANSION VALVE (TXV)

All two-stage 50TC units with Humidi-Mizer have a factory-installed nonadjustable thermostatic expansion valve (TXV). The TXV will be a bi-flow, bleed port expansion valve with an external equalizer. TXVs are specifically designed to operate with Puron or R-22 refrigerant, use only factory authorized TXVs. See Fig. 21.

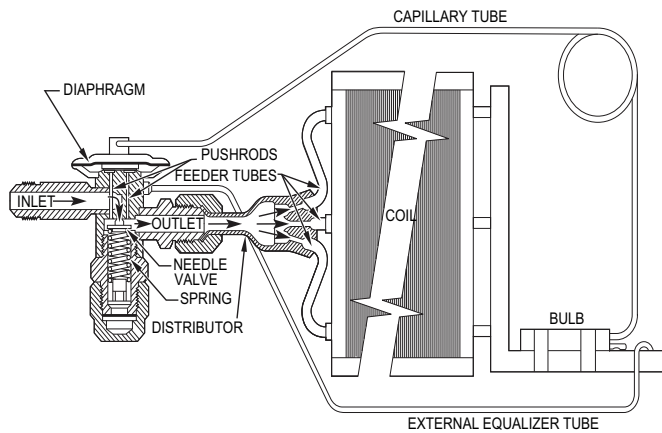

Fig. 21 — Thermostatic Expansion Valve (TXV) Operation

TXV Operation

The TXV is a metering device that is used in air conditioning and heat pump systems to adjust to changing load conditions by maintaining a preset superheat temperature at the outlet of the evaporator coil.

The volume of refrigerant metered through the valve seat is dependent upon the following:

1. Superheat temperature is sensed by the cap tube sensing bulb on suction tube at the outlet of evaporator coil. This temperature is converted into pressure by refrigerant in the bulb pushing downward on the diaphragm which opens the valve using the push rods.
2. The suction pressure at the outlet of the evaporator coil is transferred through the external equalizer tube to the underside of the diaphragm.
3. The needle valve on the pin carrier is spring loaded, exerting pressure on the underside of the diaphragm. Therefore, the bulb pressure equals the evaporator pressure (at the outlet of the coil) plus the spring pressure. If the evaporator load increases, the temperature increases at the bulb, which increases the pressure on the top side of the diaphragm, pushing the carrier away from the seat, opening the valve and increasing the flow of refrigerant. The increased refrigerant flow causes increased leaving evaporator pressure which is transferred through the equalizer tube to the underside of the diaphragm. This causes the pin carrier spring pressure to close the TXV valve. The refrigerant flow is effectively stabilized to the load demand with a negligible change in superheat.

REPLACING TXV

⚠ CAUTION

PERSONAL INJURY HAZARD

Failure to follow this caution can result in injury to personnel and damage to components.

Always wear approved safety glasses, work gloves and other recommended Personal Protective Equipment (PPE) when working with refrigerants.

1. Disconnect all AC power to the unit. Use approved lockout/tag-out procedures.
2. Using the gage set approved for use with Puron (R-410A) refrigerant, recover all refrigerant from the system.
3. Remove the TXV support clamp.
4. Disconnect the liquid line at the TXV inlet.
5. Remove the liquid line connection at the TXV inlet.
6. Remove the equalizer tube from the suction line of the coil. Use a tubing cutter to cut the brazed equalizer line approximately 2-in. (50 mm) above the suction tube.
7. Remove the bulb from the vapor tube above the evaporator coil header outlet.
8. Install the new TXV; avoid damage to the tubing or the valve when attaching the TXV to the distributor. Protect the TXV against over-temperature conditions by using wet rags and directing the torch flame tip away from the TXV body. Connect the liquid line to the TXV inlet by repeating the above process.
9. Attach the equalizer tube to the suction line. If the replacement TXV has a flare nut on its equalizer line, use a tubing cutter to remove the mechanical flare nut from the equalizer. Then use a coupling to braze the equalizer line to the stub (previous equalizer line) in the suction line.
10. Attach the TXV bulb in the same location as the original (in the sensing bulb indent), wrap the bulb in protective insulation and secure using the supplied bulb clamp. See Fig. 22 and 23.
11. Route the equalizer tube through the suction connection opening (large hole) in the fitting panel and install the fitting panel in place.
12. Sweat the inlet of the TXV marked "IN" to the liquid line. Avoid excessive heat which could damage the valve.
13. Check for leaks.
14. Evacuate the system completely and then recharge.
15. Remove the lockout/tag-out on the main power switch and restore power to the unit.
16. Complete the charging procedure.

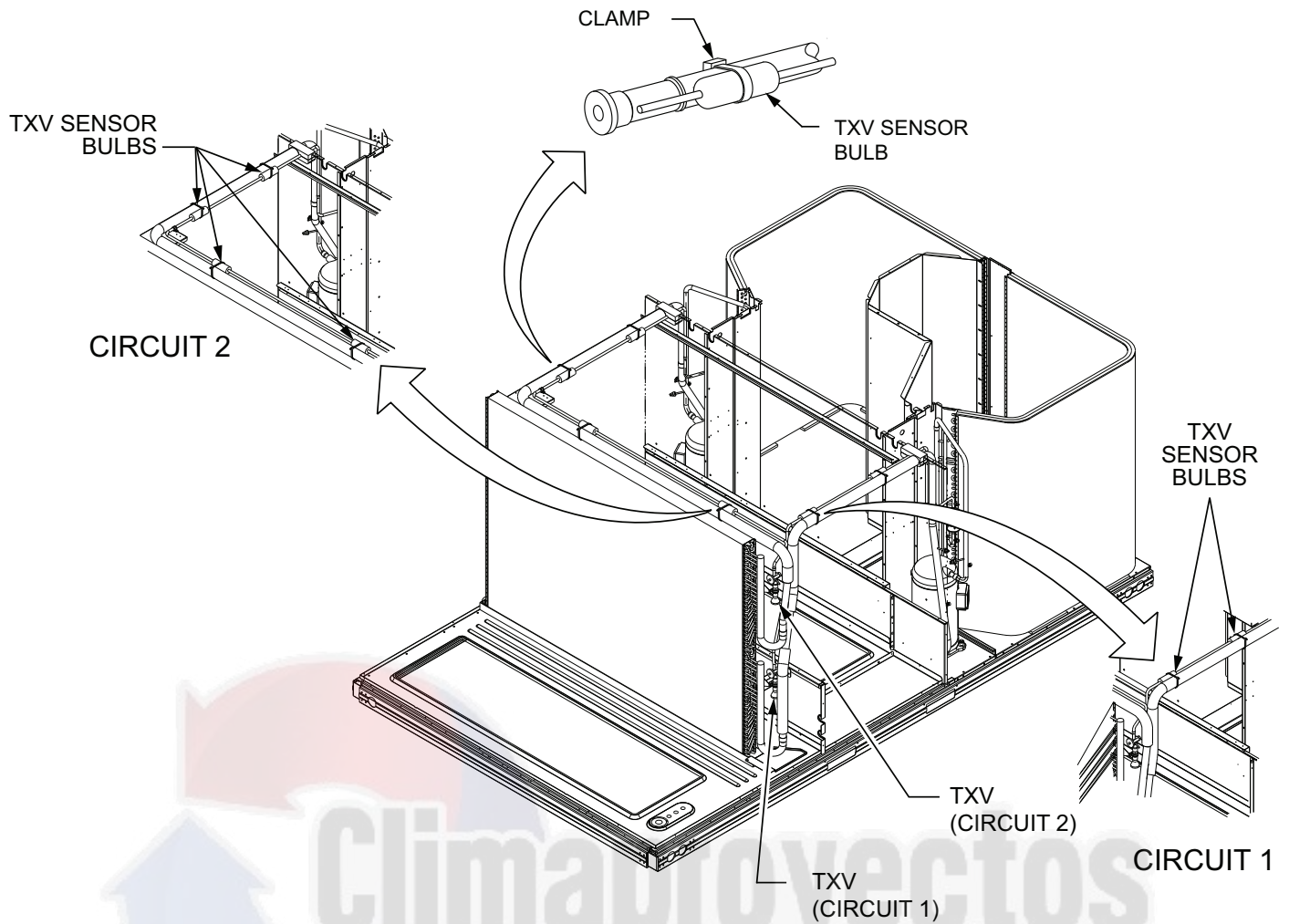

Fig. 22 — TXV Sensor Bulb Locations

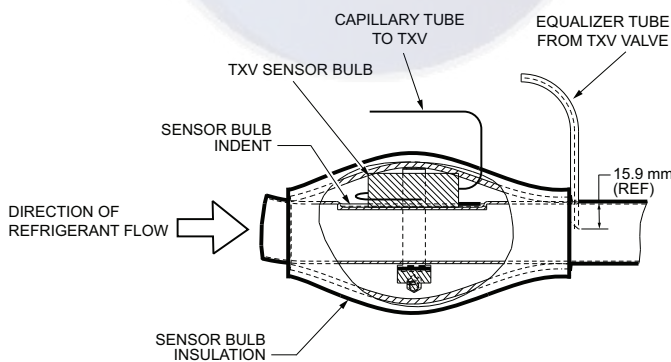

Fig. 23 — TXV Sensor Valve Insulation

Refrigerant System Pressure Access Ports

There are two access ports in the system: on the suction tube near the compressor, and on the discharge tube near the compressor. These are brass fittings with black plastic caps. The hose connection fittings are standard 1/4-in. SAE male flare couplings. See Fig. 15.

The brass fittings are two-piece High Flow valves, with a receptacle base brazed to the tubing and an integral spring-closed check valve core screwed into the base. This check valve is permanently assembled into this core body and cannot be serviced separately; replace the entire core body if necessary. Service tools are available from RCD that allow the replacement of the check valve core without having to recover the entire system refrigerant charge.

Apply compressor refrigerant oil to the check valve core's bottom o-ring. Install the fitting body with 96 ± 10 in.-lb of torque; do not over-tighten.

PURON (R-410A) REFRIGERANT

This unit is designed for use with Puron (R-410A) refrigerant. Do not use any other refrigerant in this system.

⚠ CAUTION

UNIT DAMAGE HAZARD

Failure to follow this caution may result in damage to components.

The compressor is in a R-410A refrigerant system and uses a polyolester (POE) oil. This oil is extremely hygroscopic, meaning it absorbs water readily. POE oils can absorb 15 times as much water as other oils designed for HCFC and CFC refrigerants. Avoid exposure of the oil to the atmosphere.

Puron (R-410A) refrigerant is provided in pink (rose) colored cylinders. These cylinders are available with and without dip tubes; cylinders with dip tubes will have a label indicating this feature. For a cylinder with a dip tube, place the cylinder in the upright position (access valve at the top) when removing liquid refrigerant for charging. For a cylinder without a dip tube, invert the cylinder, with the access valve located on the bottom, when adding liquid refrigerant.

Because Puron (R-410A) refrigerant is a blend, it is strongly recommended that refrigerant always be removed from the cylinder as a liquid. Admit liquid refrigerant into the system in the discharge line when breaking the refrigerant system vacuum while the compressor is OFF. Only add refrigerant (liquid) into the suction line while the compressor is operating. If adding refrigerant into the suction line, use a commercial metering/expansion device at the gage manifold; remove liquid from the cylinder, pass it through the metering device at the gage set, and then pass it into the suction line as a vapor. Do not remove Puron (R-410A) refrigerant from the cylinder as a vapor.

Refrigerant Charge

Unit panels must be in place when the unit is operating during the charging procedure. To prepare the unit for charge adjustment, use the following instructions.

NO CHARGE

Use standard evacuating techniques. Evacuate the system down to 500 microns and let set for 10 minutes to determine if the system has a refrigerant leak. If the evacuation level raises to 1100 microns and stabilizes, then the system has moisture in it and should be dehydrated as GTAC2-5 recommends.

If the system continues to rise above 1100 microns, then the system has a leak and should be pressurized and leak tested using appropriate techniques as explained in GTAC2-5. After evacuating the system, weigh in the specified amount of refrigerant as listed on the unit's rating plate.

LOW-CHARGE COOLING

Using the Cooling Charging Charts (Fig. 19-22), vary the refrigerant until the conditions of the appropriate chart are met. Note the charging charts are different from the type normally used. These charts are based on charging the units to the correct superheat for the various operating conditions. Accurate pressure gage and temperature sensing devices are required. Connect the pressure gage to the service port on the suction line. Mount the temperature sensing device on the suction line and insulate it so the outdoor ambient temperature does not affect the reading. Indoor-air cfm must be within the normal operating range of the unit.

EXAMPLE:

Model 50TC*D28

Circuit A

Outdoor Temperature 85°F (29°C)

Suction Pressure 125 psig (860 kPa)

Suction Temperature should be 63°F (17°C)

Circuit B

Outdoor Temperature 85°F (29°C)

Suction Pressure 120 psig (830 kPa)

Suction Temperature should be 58°F (14°C)

Using the Cooling Charging Charts

Take the outdoor ambient temperature and read the suction pressure gage. Refer to the chart to determine what the suction temperature should be. If the suction temperature is high, add refrigerant.

If the suction temperature is low, carefully recover some of the charge. Recheck the suction pressure as the charge is adjusted.

Select the appropriate unit charging chart from Fig. 19-22.

Note the outdoor ambient temperature and read the suction pressure gage. Refer to the chart to determine what the suction temperature should be. If the suction temperature is high, add refrigerant. If the suction temperature is low, carefully recover some of the charge. Recheck the suction pressure as the charge is adjusted.

For 17-28 sizes, perform this procedure once for Circuit A (using the Circuit A chart) and once for Circuit B (using the Circuit B chart).

COOLING CHARGING CHARTS

COOLING CHARGING CHART 15 and 17.5 Ton - Circuit A

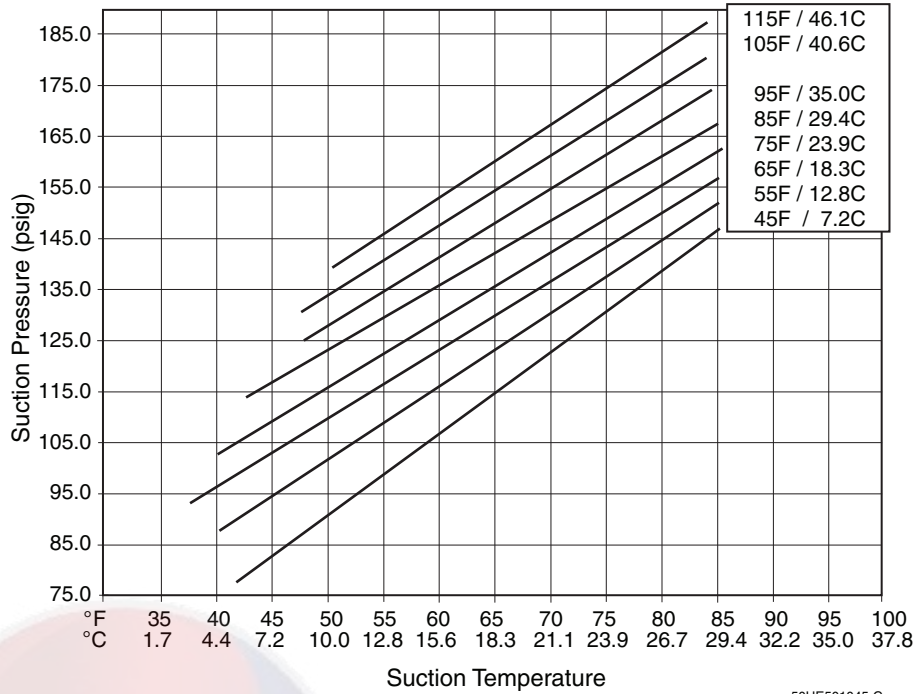

Fig. 24 — Cooling Charging Chart - 15, 17.5 Ton (Circuit A)

COOLING CHARGING CHART 15 and 17.5 Ton - Circuit B

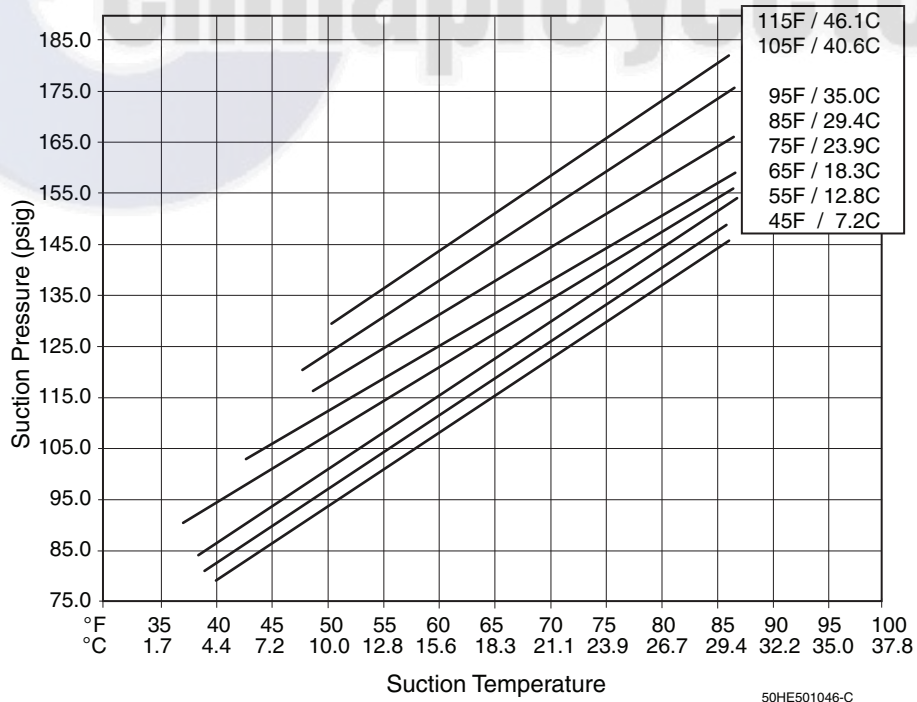

Fig. 25 — Cooling Charging Chart - 15, 17.5 Ton (Circuit B)

**COOLING CHARGING CHART
20 Ton - Circuit A**

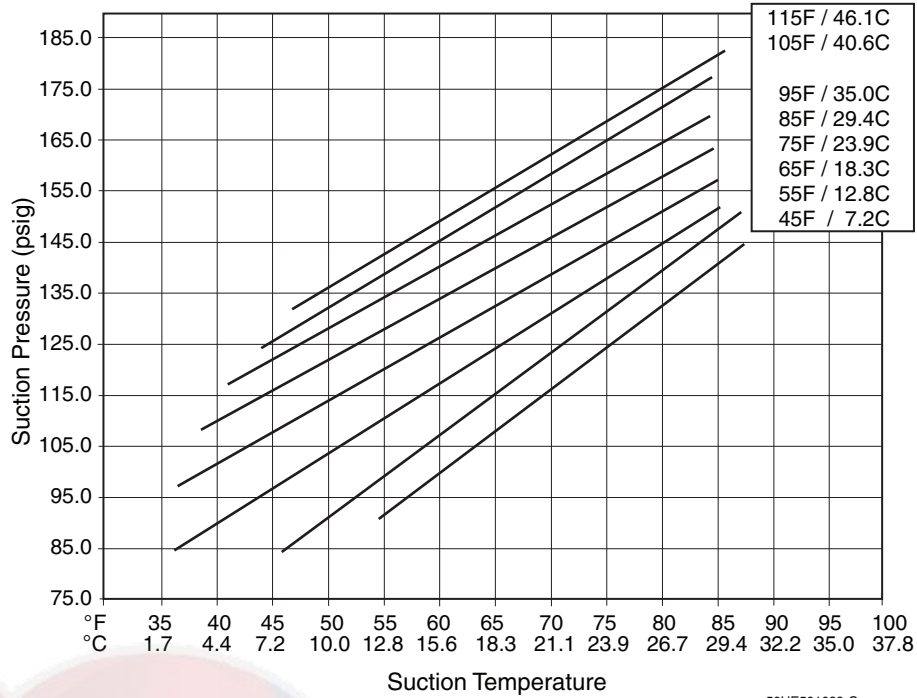

Fig. 26 — Cooling Charging Chart - 20 Ton (Circuit A)

**COOLING CHARGING CHART
20 Ton - Circuit B**

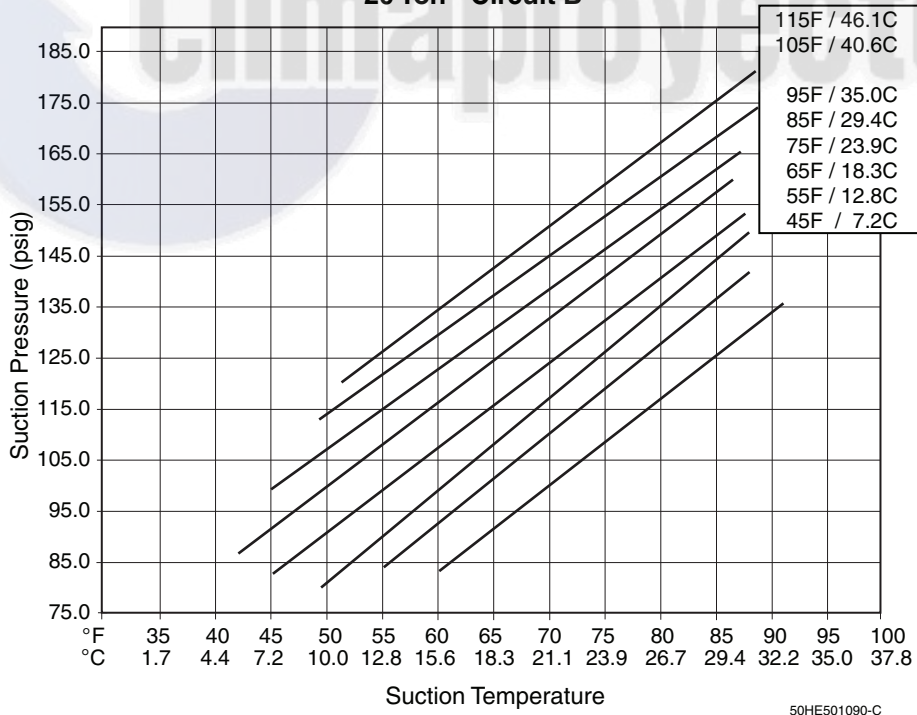
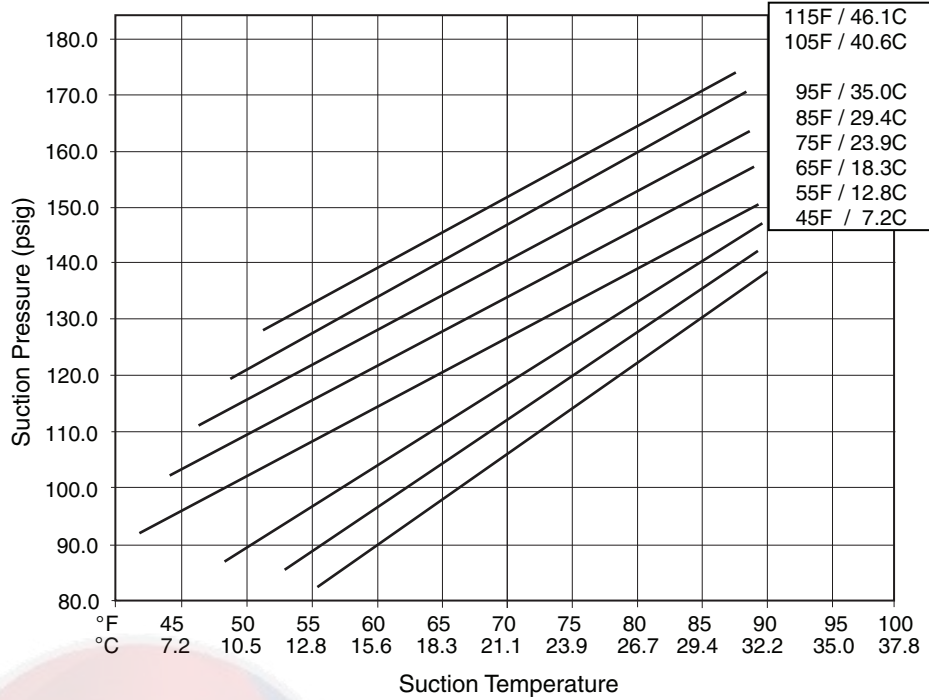

Fig. 27 — Cooling Charging Chart - 20 Ton (Circuit B)

**COOLING CHARGING CHART
25.0 Ton - Circuit A**



50HE501091-C

Fig. 28 — Cooling Charging Chart - 25 Ton (Circuit A)

**COOLING CHARGING CHART
25.0 Ton - Circuit B**

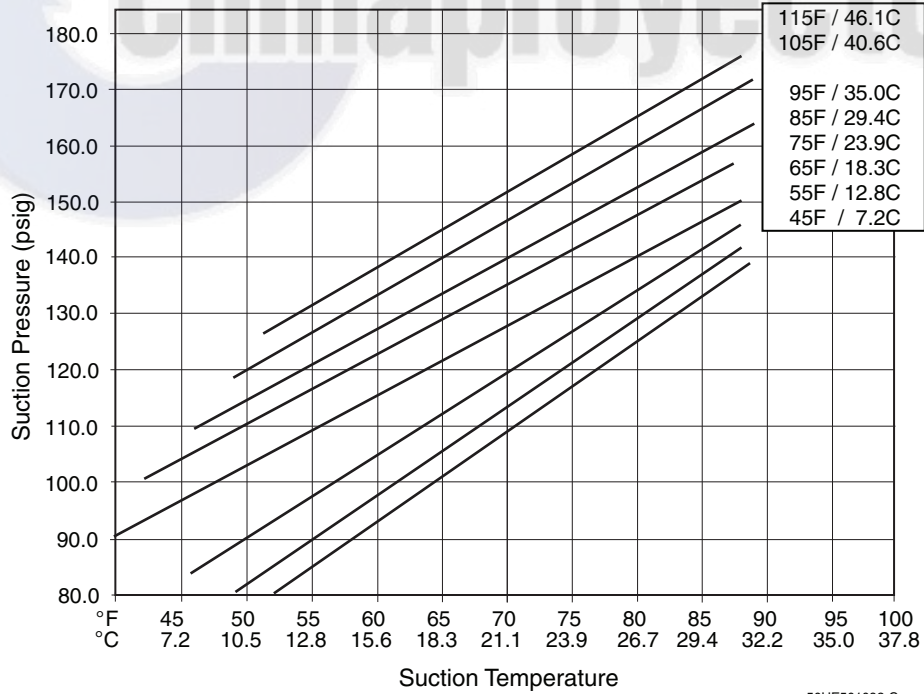

50HE501092-C

Fig. 29 — Cooling Charging Chart - 25 Ton (Circuit B)

COOLING CHARGING CHART 27.5 Ton - Circuit A

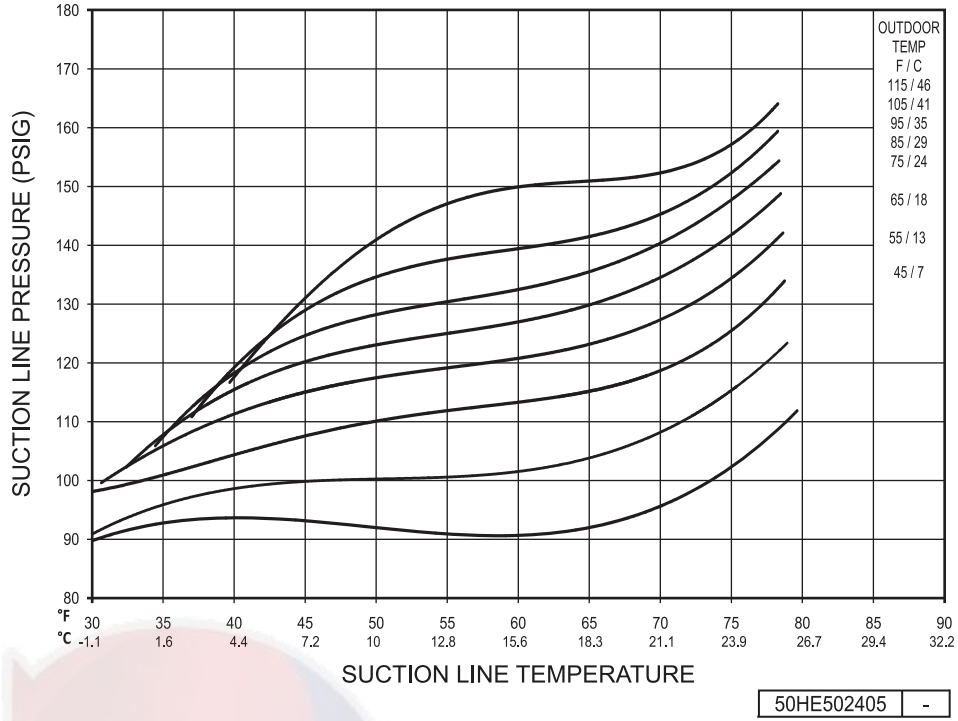

Fig. 30 — Cooling Charging Chart - 27.5 Ton (Circuit A)

COOLING CHARGING CHART 27.5 Ton - Circuit B

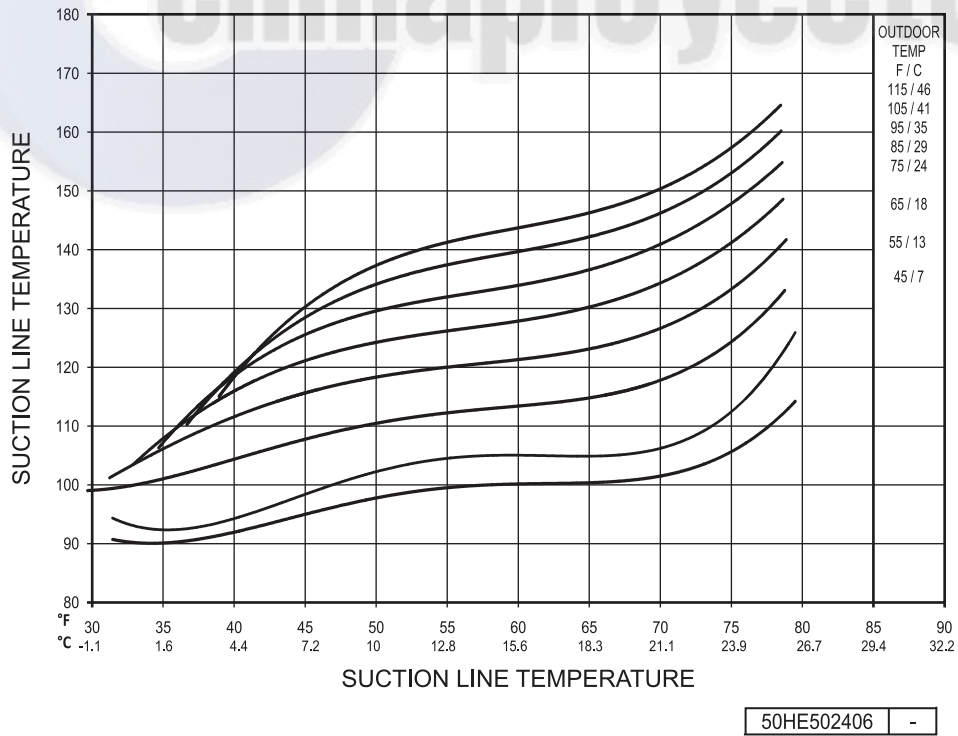

Fig. 31 — Cooling Charging Chart - 27.5 Ton (Circuit B)

COMPRESSORS

Lubrication

The compressor is charged with the correct amount of oil at the factory.

⚠ WARNING

FIRE, EXPLOSION HAZARD

Failure to follow this warning could result in death, serious personal injury and/or property damage.

Never use air or gases containing oxygen for leak testing or for operating refrigerant compressors. Pressurized mixtures of air or gases containing oxygen can lead to an explosion.

⚠ WARNING

PERSONAL INJURY AND ENVIRONMENTAL HAZARD

Failure to follow this warning could cause personal injury or death.

Relieve pressure and recover all refrigerant before system repair or final unit disposal.

Wear safety glasses and gloves when handling refrigerants. Keep torches and other ignition sources away from refrigerants and oils.

⚠ WARNING

FIRE, EXPLOSION HAZARD

Failure to follow this warning could result in death, serious personal injury and/or property damage.

Never use non-certified refrigerants in this product. Non-certified refrigerants could contain contaminants that could lead to unsafe operating conditions. Use ONLY refrigerants that conform to AHRI Standard 700.

Replacing the Compressor

The compressor using Puron refrigerant contains a POE oil. This oil has a high affinity for moisture. Do not remove the compressor's tube plugs until ready to insert the unit suction and discharge tube line ends.

⚠ CAUTION

UNIT DAMAGE HAZARD

Failure to follow this caution may result in damage to components.

The compressor is in a R-410A refrigerant system and uses a polyolester (POE) oil. This oil is extremely hygroscopic, meaning it absorbs water readily. POE oils can absorb 15 times as much water as other oils designed for HCFC and CFC refrigerants. Avoid exposure of the oil to the atmosphere.

NOTE: Only factory-trained service technicians should remove and replace compressor units.

COMPRESSOR MOUNTING BOLTS

Compressor mounting bolts should be periodically inspected for proper tightness. Bolts should be tightened and have the torque set at 65 to 75 in.-lb (7.3 to 8.5 Nm).

Compressor Rotation

On 3-phase units with scroll compressors, it is important to be certain the compressor is rotating in the proper direction. To determine whether or not the compressor is rotating in the proper direction:

1. Connect service gages to suction and discharge pressure fittings.
2. Energize the compressor.
3. The suction pressure should drop and the discharge pressure should rise, as is normal on any start-up.

NOTE: If the suction pressure does not drop and the discharge pressure does not rise to normal levels:

4. Note that the evaporator fan is probably also rotating in the wrong direction.
5. Turn off power to the unit. Use applicable lockout/tag-out procedures.
6. Reverse any two of the unit power leads.
7. Reapply power to the compressor.

The suction and discharge pressure levels should now move to their normal start-up levels.

NOTE: When the compressor is rotating in the wrong direction, the unit makes an elevated level of noise and does not provide cooling.

Filter Drier

Replace the filter drier whenever the refrigerant system is exposed to atmosphere. Only use factory specified liquid-line filter driers with working pressures no less than 650 psig (4482 kPa). Do not install a suction-line filter drier in liquid line. A liquid-line filter drier designed for use with Puron refrigerant is required on every unit.

REPLACING THE FILTER DRIER

Use the following steps to replace the filter drier.

1. Using a Puron (R-410A) gage set, recover all refrigerant from the system.
2. Use a tubing cutter to remove the filter drier from the line.

NOTE: Do not use a torch to remove the old filter drier. The heat from the torch will allow contaminants into the air and into the open refrigeration system.

3. Sweat a new replacement filter drier into the refrigerant line.
4. Re-charge the refrigerant system.

Adjusting the Condenser-Fan

1. Shut off the unit power supply. Apply the appropriate lockout/tag-out procedures.
2. Remove the condenser-fan assembly (grille, motor, and fan).
3. Loosen the fan hub setscrews.
4. Adjust the fan height as shown in Fig. 32.
5. Tighten the setscrews.
6. Replace the condenser-fan assembly.

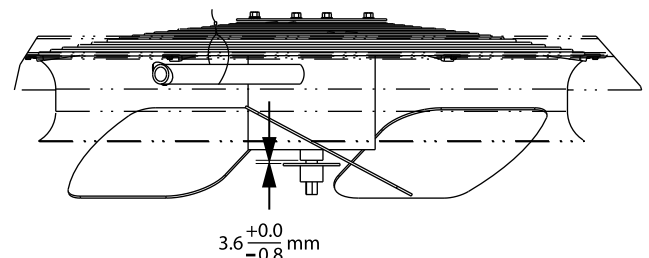

Fig. 32 — Condenser Fan Adjustment

TROUBLESHOOTING THE COOLING SYSTEM

Refer to Table 5 for additional troubleshooting topics.

Table 5 — Cooling Service Troubleshooting

PROBLEM	CAUSE	REMEDY
Compressor and Condenser Fan Will Not Start	Power failure.	Call power company.
	Fuse blown or circuit breaker tripped.	Replace fuse or reset circuit breaker.
	Defective thermostat, contactor, transformer, or control relay.	Replace defective component.
	Insufficient line voltage.	Determine cause and correct.
	Incorrect or faulty wiring.	Check wiring diagram and rewire correctly.
	Thermostat setting too high.	Lower thermostat setting below room temperature.
Compressor Will Not Start But Condenser Fan Runs	Faulty wiring or loose connections in compressor circuit.	Check wiring and repair or replace. Tighten loose connections.
	Compressor motor burned out, seized, or internal overload open.	Determine cause. Replace compressor.
	Defective run/start capacitor, overload, start relay.	Determine cause and replace defective component.
	One leg of three-phase power dead.	Replace fuse or reset circuit breaker. Determine cause.
Compressor Cycles (other than normally satisfying thermostat)	Refrigerant overcharge or undercharge.	Recover refrigerant, evacuate system, and recharge to values on nameplate.
	Defective compressor.	Replace defective compressor.
	Insufficient line voltage.	Determine cause and correct.
	Blocked condenser.	Determine cause and correct.
	Defective run/start capacitor, overload, or start relay.	Determine cause and replace.
	Defective thermostat.	Replace thermostat.
	Faulty condenser-fan motor or capacitor.	Replace. Defective fan motor or capacitor.
	Restriction in refrigerant system.	Locate restriction and remove.
Compressor Operates Continuously	Dirty air filter.	Replace filter.
	Unit undersized for load.	Decrease load or replace with larger unit.
	Thermostat set too low.	Reset thermostat.
	Low refrigerant charge.	Locate leak; repair and recharge.
	Leaking valves in compressor.	Replace compressor.
	Air in system.	Recover refrigerant, evacuate system, and recharge.
	Condenser coil dirty or restricted.	Clean coil or remove restriction.
Excessive Head Pressure	Dirty air filter.	Replace air filter.
	Dirty condenser coil.	Clean condenser coil.
	Refrigerant overcharged.	Recover excess refrigerant.
	Faulty TXV valve.	1. Check TXV bulb mounting and secure tightly to suction line and insulate. 2. Replace TXV valve and filter drier if stuck open or closed.
	Air in system.	Recover refrigerant, evacuate system, and recharge.
	Condenser air restricted or air short-cycling.	Determine cause and correct.
Head Pressure Too Low	Low refrigerant charge.	Check for leaks; repair and recharge.
	Compressor valves leaking.	Replace compressor.
	Restriction in liquid tube.	Remove restriction.
Excessive Suction Pressure	High head load.	Check for source and eliminate.
	Compressor valves leaking.	Replace compressor.
	Refrigerant overcharged.	Recover excess refrigerant.
Suction Pressure Too Low	Dirty air filter.	Replace filter.
	Low refrigerant charge.	Check for leaks; repair and recharge.
	Metering device or low side restricted.	Remove source of restriction.
	Faulty TXV valve.	1. Check TXV bulb mounting and secure tightly to suction line and insulate. 2. Replace TXV valve and filter drier if stuck open or closed.
	Insufficient evaporator airflow.	Increase air quantity. Check filter and replace if necessary. Check belt tension on blower.
	Temperature too low in conditioned area.	Reset thermostat.
	Outdoor ambient below 25°F.	Install low-ambient kit.
Evaporator Fan Will Not Shut Off	Time off delay not finished.	Wait for 30 second off delay.
Compressor Makes Excessive Noise	Compressor rotating in wrong direction.	Reverse the 3 phase power leads.

CONVENIENCE OUTLETS

⚠ WARNING

ELECTRICAL OPERATION HAZARD

Failure to follow this warning could result in personal injury or death.

Units with convenience outlet circuits may use multiple disconnects. Check convenience outlet for power status before opening unit for service. Locate its disconnect switch, if appropriate, and open it. Lock-out and tag-out this switch, if necessary.

Two types of convenience outlets are offered on 50TC models: non-powered and unit-powered. Both types provide a 125-v Ground-Fault Circuit-Interrupter (GFCI) duplex receptacle rated at 15A behind a hinged waterproof access cover, located on the end panel of the unit. See Fig. 33.

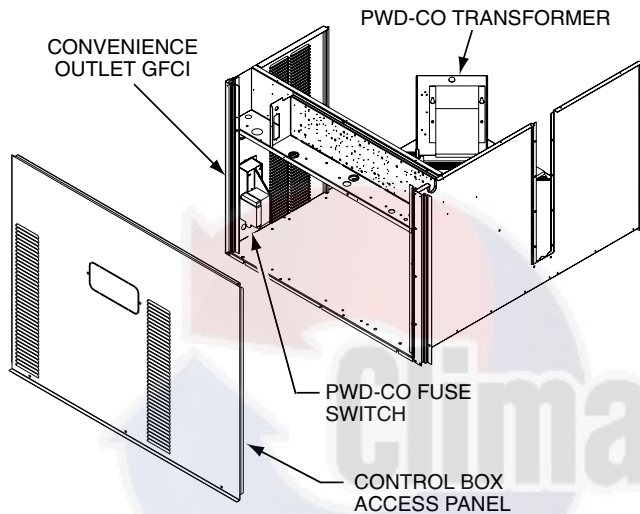

Fig. 33 — Convenience Outlet Location

Non-Powered Type

This type requires the field installation of a general-purpose 125-v 15A circuit powered from a source elsewhere in the building. Observe national and local codes when selecting wire size, fuse or breaker requirements and disconnect switch size and location. Route 125-v power supply conductors into the bottom of the utility box containing the duplex receptacle.

Unit-Powered Type

A unit-mounted transformer is factory-installed to stepdown the main power supply voltage to the unit to 115-v at the duplex receptacle. This option also includes a manual switch with fuse, located in a utility box and mounted on a bracket behind the convenience outlet; access is through the unit's control box access panel. See Fig. 34 for wiring.

DUTY CYCLE

The unit-powered convenience outlet has a duty cycle limitation. The transformer is intended to provide power on an intermittent basis for service tools, lamps, etc. It is not intended to provide 15 amps loading for continuous duty loads (such as electric heaters for overnight use). Observe a 50% limit on circuit loading above 8 amps (i.e., limit loads exceeding 8 amps to 30 minutes of operation every hour).

The primary leads to the convenience outlet transformer are not factory-connected. Selection of primary power source is a customer option. If local codes permit, the transformer primary leads can be connected at the line-side terminals on a unit-mounted non-fused disconnect or circuit breaker switch; this will provide

service power to the unit when the unit disconnect switch or circuit breaker is open. Other connection methods will result in the convenience outlet circuit being de-energized when the unit disconnect or circuit breaker is open. See Fig. 34.

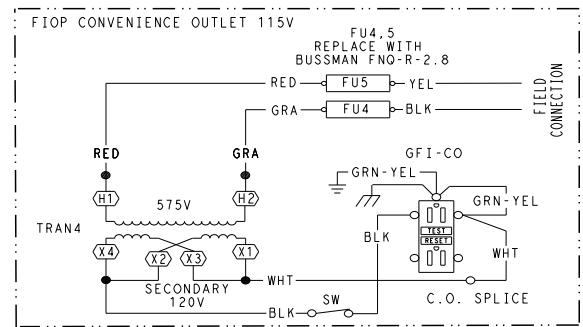
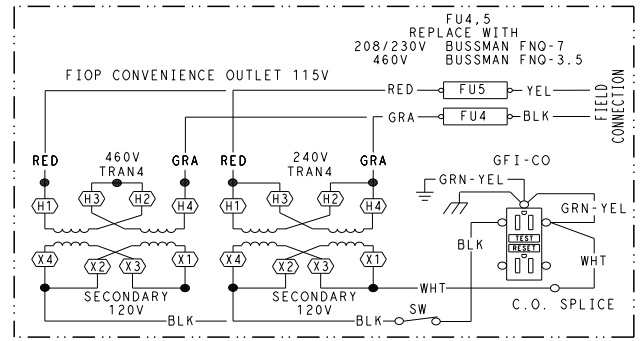

LEGEND

	MARKED WIRE
	TERMINAL (MARKED)
	TERMINAL (UNMARKED)
	TERMINAL BLOCK
	SPLICE
	SPLICE (MARKED)
	FACTORY WIRING
	FIELD CONTROL WIRING
	FIELD POWER WIRING
	CIRCUIT BOARD TRACE
	ACCESSORY WIRING
	TO INDICATE COMMON POTENTIAL ONLY: NOT TO REPRESENT WIRING

UNIT VOLTAGE	CONNECT AS	PRIMARY CONNECTIONS	TRANSFORMER TERMINALS
208,230	240	L1: RED + YEL L2: BLU + GRA	H1 + H3 H2 + H4
460	480	L1: RED Splice BLU + YEL L2: GRA	H1 H2 + H3 H4
575	600	L1: RED L2: GRA	H1 H2

Fig. 34 — Powered Convenience Outlet Wiring

Wet in Use Convenience Outlet Cover

The unit has a "wet in use" convenience outlet cover that must be installed on the panel containing the convenience outlet. This cover provides protection against moisture entering the GFCI receptacle. This cover is placed in the unit control box during shipment.

GFCI Maintenance

Periodically test the GFCI receptacle by pressing the TEST button on the face of the receptacle.

1. Press the TEST button on the face of the receptacle. This should cause the internal circuit of the receptacle to trip and open the receptacle.
2. Check for proper grounding and power line phasing should the GFCI receptacle fail to trip.

3. Repair ground wire connections as needed and correct the line phasing.
4. Press RESET button to clear the tripped condition.

Fuse On Powered Type

The factory fuse is a Bussmann¹ “Fusetron” T-15, non-renewable screw-in (Edison base) type plug fuse.

Using Unit-Mounted Convenience Outlets

Units with unit-mounted convenience outlet circuits will often require that two disconnects be opened to de-energize all power to the unit. Treat all units as electrically energized until the convenience outlet power is also checked and de-energization is confirmed. Observe National Electrical Code Article 210, Branch Circuits, for use of convenience outlets. Always use a volt meter to verify no voltage is present at the GFCI receptacles before working on the unit.

Installing a Weatherproof Cover

A weatherproof while-in-use cover for the factory installed convenience outlets is now required by UL standards. This cover cannot be factory-mounted due to its depth. The cover must be installed at the unit installation. For shipment, the convenience outlet is covered with a blank cover plate.

The weatherproof cover kit is shipped in the unit’s control box. The kit includes the hinged cover, backing plate and gasket.

⚠ DANGER
ELECTRICAL SHOCK HAZARD
Failure to follow this warning will result in personal injury or death.
Before performing service or maintenance operations on unit, turn off main power switch to unit and install lock(s) and lock-out tag(s). Ensure electrical service to rooftop unit agrees with voltage and amperage listed on the unit rating plate. Unit may have more than one power switch.

1. Remove the blank cover plate at the convenience outlet. Discard the blank cover.
2. Loosen the two screws at the GFCI duplex outlet until approximately 1/2-in. (13 mm) under the screw heads is exposed.
3. Press the gasket over the screw heads. Slip the backing plate over the screw heads at the keyhole slots and align with the gasket; tighten the two screws until snug. Do not over-tighten.
4. Mount the weatherproof cover to the backing plate as shown in Fig. 35.
5. Remove two slot fillers in the bottom of the cover to allow service tool cords to exit the cover.
6. Check the cover installation to confirm full closing and latching.

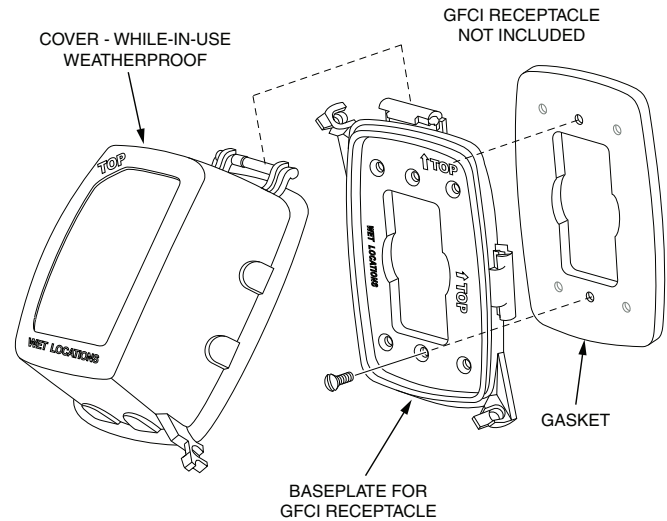

Fig. 35 — Weatherproof Cover Installation

SMOKE DETECTORS

Smoke detectors are available as factory-installed options on 50TC models. Smoke detectors may be specified for supply air only, for return air without or with economizer, or in combination of supply air and return air. Return-air smoke detectors are arranged for vertical return configurations only. All components necessary for operation are factory-provided and mounted. The unit is factory-configured for immediate smoke detector shutdown operation; additional wiring or modifications to unit terminal board may be necessary to complete the unit and smoke detector configuration to meet project requirements.

System

The smoke detector system consists of a four-wire controller and one or two sensors. Its primary function is to shut down the rooftop unit in order to prevent smoke from circulating throughout the building. It is not to be used as a life saving device.

Controller

The controller (see Fig. 36) includes a controller housing, a printed circuit board, and a clear plastic cover. The controller can be connected to one or two compatible duct smoke sensors. The clear plastic cover is secured to the housing with a single captive screw for easy access to the wiring terminals. The controller has three LEDs: Power, Trouble and Alarm. A manual test/reset button is located on the cover face.

1. Bussmann and Fusetron are trademarks of Cooper Technologies Company.

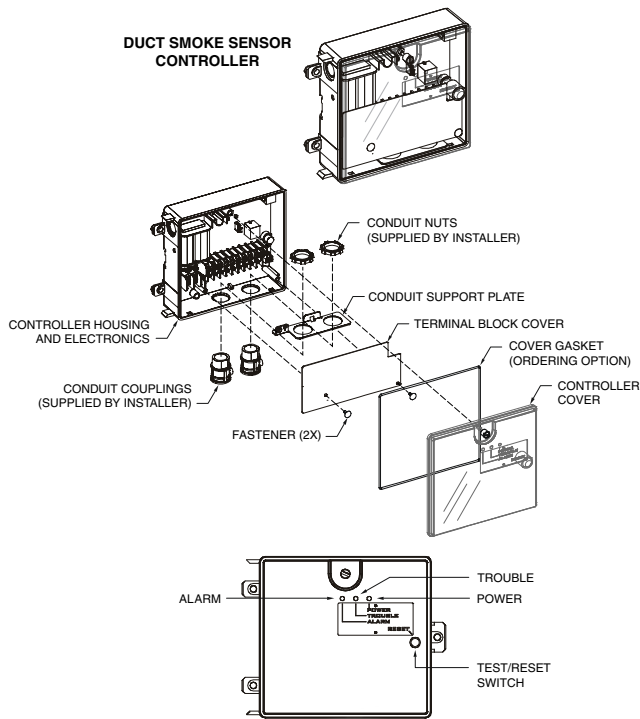

Fig. 36 — Controller Assembly

Sensor

The sensor (see Fig. 37) includes a plastic housing, a printed circuit board, a clear plastic cover, a sampling tube inlet and an exhaust tube. The sampling tube, when used, and exhaust tube are attached during installation. The sampling tube varies in length depending on the size of the rooftop unit. The clear plastic cover permits visual inspections without having to disassemble the sensor. The cover attaches to the sensor housing using four captive screws and forms an airtight chamber around the sensing electronics. Each sensor includes a harness with an RJ45 terminal for connecting to the controller. Each sensor has four LEDs: Power, Trouble, Alarm, and Dirty. A manual test/reset button is located on the left side of the housing.

Air is introduced to the duct smoke detector sensor’s sensing chamber through a sampling tube that extends into the HVAC duct and is directed back into the ventilation system through a (shorter) exhaust tube. The difference in air pressure between the two tubes pulls the sampled air through the sensing chamber. When a sufficient amount of smoke is detected in the sensing chamber, the sensor signals an alarm state and the controller automatically takes the appropriate action to shut down fans and blowers, change over air handling systems, notify the fire alarm control panel, etc.

The sensor uses a photoelectric (light scattering principle) process called differential sensing to prevent gradual environmental changes from triggering false alarms. A rapid change in environmental conditions, such as smoke from a fire, causes the sensor to signal an alarm state but dust and debris accumulated over time does not.

For installations using two sensors, the duct smoke detector does not differentiate which sensor signals an alarm or trouble condition.

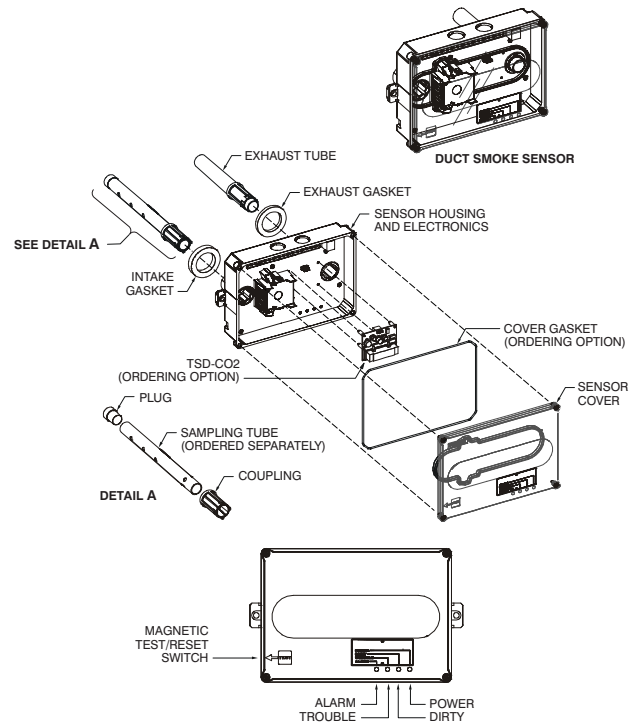

Fig. 37 — Smoke Detector Sensor

Smoke Detector Locations

SUPPLY AIR

The supply-air smoke detector sensor is located to the left of the unit’s indoor (supply) fan. See Fig. 38. Access is through the fan access panel. There is no sampling tube used at this location. The sampling tube inlet extends through the side plate of the fan housing (into a high pressure area). The controller is located on a bracket to the right of the return filter, accessed through the lift-off filter panel.

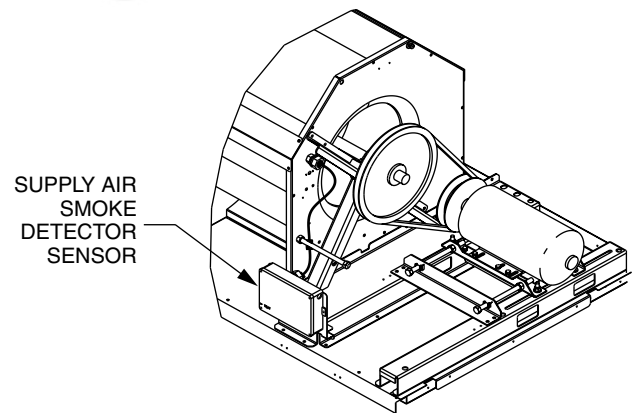
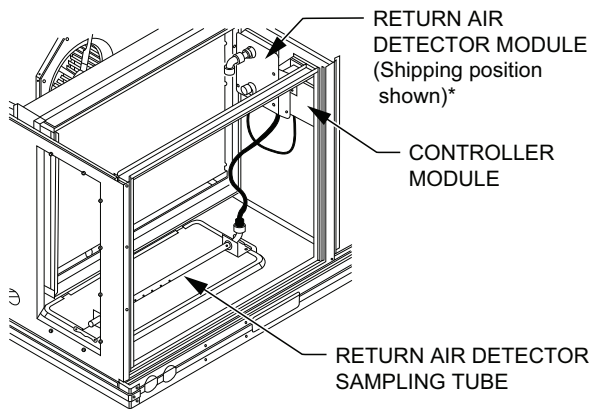

Fig. 38 — Typical Supply Air Smoke Detector Sensor Location

RETURN AIR WITHOUT ECONOMIZER

The sampling tube is located across the return air opening on the unit basepan. See Fig. 39. The holes in the sampling tube face downward, into the return air stream. The sampling tube is attached to the control module bushing that extends from the control box through the partition into the return air section of the unit. The sensor tube is shipped mounted to the indoor blower housing and must be relocated to the return air section of the unit. Installation requires that this sensing tube be attached to the control module bushing. See installation steps.



*RA detector must be moved from shipping position to operating position by installer.

Fig. 39 — Typical Return Air Detector Location

RETURN AIR WITH ECONOMIZER

The sampling tube is inserted through the side plates of the economizer housing, placing it across the return air opening on the unit basepan. See Fig. 40. The holes in the sampling tube face downward, into the return air stream. The sampling tube is connected through tubing to the return air sensor that is mounted on a bracket high on the partition between return filter and controller location. The return air sensor is shipped in a flat-mounting location. Installation requires that this sensor be relocated to its operating location and the tubing to the sampling tube be connected. See installation steps.

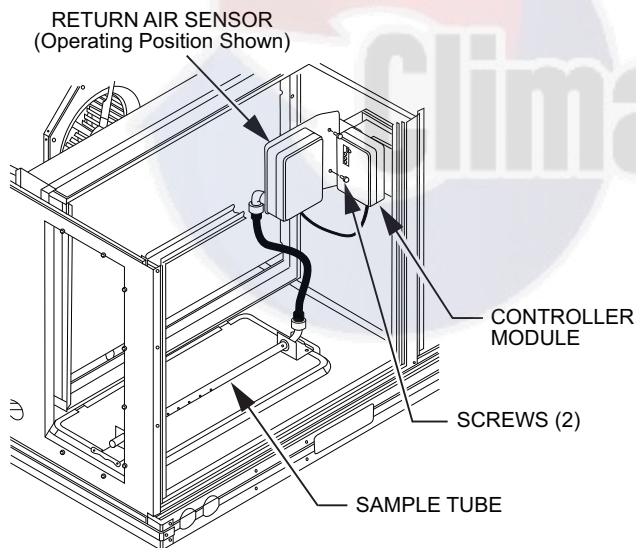

Fig. 40 — Return Air Sampling Tube Location in Unit with Economizer

FIOP Smoke Detector Wiring and Response

ALL UNITS

The FIOP smoke detector is configured to automatically shut down all unit operations when a smoke condition is detected. See Fig. 41 for smoke detector wiring.

HIGHLIGHT A

The JMP 3 is factory-cut, transferring unit control to the smoke detector.

HIGHLIGHT B

The smoke detector NC contact set will open on a smoke alarm condition, de-energizing the ORN conductor.

HIGHLIGHT C

24-v power signal using the ORN lead is removed at the smoke detector input on the Central Terminal board (CTB); all unit operations cease immediately.

PREMIERLINK AND RTU-OPEN CONTROLS

Unit operating functions (fan, cooling and heating) are terminated as described above.

Highlight D

On smoke alarm condition, the smoke detector NO Alarm contact will close, supplying 24-v power to the GRA conductor.

Highlight E

The GRA lead at the Smoke Alarm input on LCTB provides a 24-v signal to the FIOP DDC control.

PremierLink

This signal is conveyed to PremierLink FIOP's TB1 at terminal TB1-6 (BLU lead). This signal initiates the FSD sequence by the PremierLink control. FSD status is reported to the connected CCN network.

RTU-Open

The 24-v signal is conveyed to the RTU-OPEN J1-10 input terminal. This signal initiates the FSD sequence by the RTU-OPEN control. FSD status is reported to the connected BAS network.

USING REMOTE LOGIC

Five field-use conductors are provided for field use (see Highlight F in Fig. 41) for additional annunciation functions.

ADDITIONAL APPLICATION DATA

Refer to *Factory-Installed Smoke Detectors for Small and Medium Rooftop Units 2 to 25 Tons* for discussions on additional control features of these smoke detectors, including multiple unit coordination. See Fig. 41.

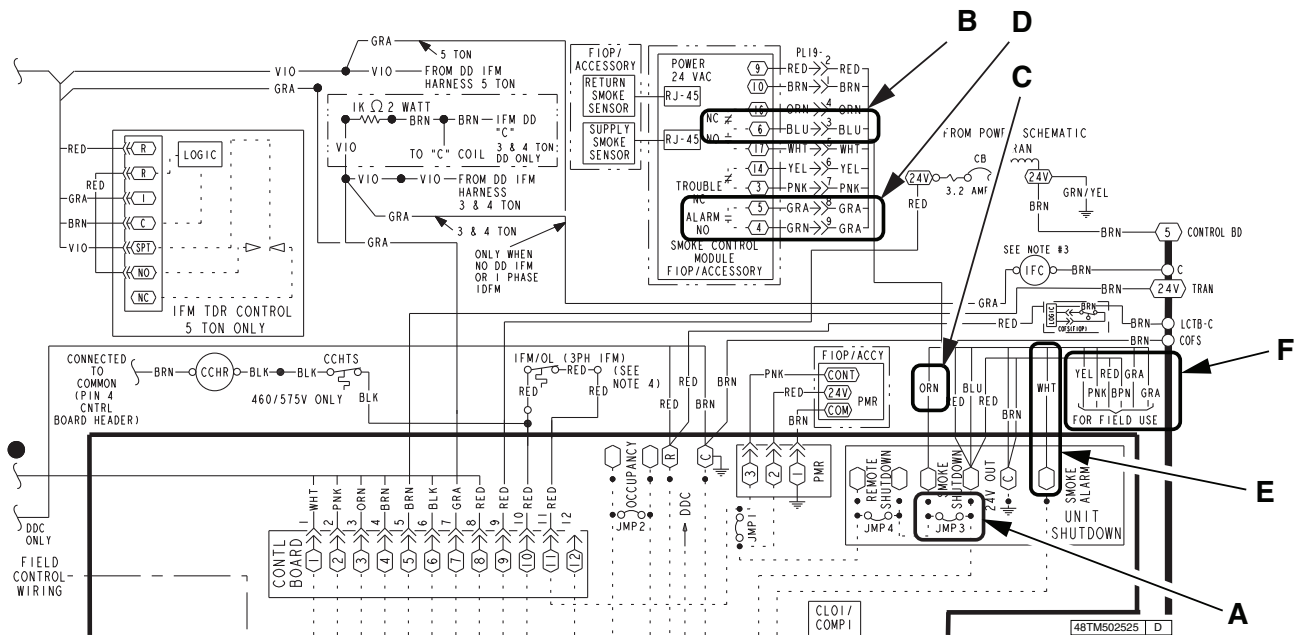

Fig. 41 — Typical Smoke Detector System Wiring

Sensor and Controller Tests

SENSOR ALARM TEST

The sensor alarm test checks a sensor’s ability to signal an alarm state. This test requires the use of a field provided SD-MAG test magnet.

NOTICE: OPERATIONAL TEST NOTICE

Failure to follow this NOTICE may result in an unnecessary evacuation of the facility.

This test places the duct detector into the alarm state. Unless part of the test, disconnect all auxiliary equipment from the controller before performing the test. If the duct detector is connected to a fire alarm system, notify the proper authorities before performing the test.

Sensor Alarm Test Procedure

1. Hold the test magnet where indicated on the side of the sensor housing for seven seconds.
2. Verify that the sensor’s Alarm LED turns on.
3. Reset the sensor by holding the test magnet against the sensor housing for two seconds.
4. Verify that the sensor’s Alarm LED turns off.

CONTROLLER ALARM TEST

The controller alarm test checks the controller’s ability to initiate and indicate an alarm state.

NOTICE: OPERATIONAL TEST NOTICE

Failure to follow this NOTICE may result in an unnecessary evacuation of the facility.

This test places the duct detector into the alarm state. Unless part of the test, disconnect all auxiliary equipment from the controller before performing the test. If the duct detector is connected to a fire alarm system, notify the proper authorities before performing the test.

Controller Alarm Test Procedure

1. Press the controller’s test/reset switch for seven seconds.
2. Verify that the controller’s Alarm LED turns on.
3. Reset the sensor by pressing the test/reset switch for two seconds.
4. Verify that the controller’s Alarm LED turns off.

DIRTY CONTROLLER TEST

The dirty controller test checks the controller’s ability to initiate a dirty sensor test and indicate its results.

NOTICE: OPERATIONAL TEST NOTICE

Failure to follow this NOTICE may result in an unnecessary evacuation of the facility.

Pressing the controller’s test/reset switch for longer than seven seconds will put the duct detector into the alarm state and activate all automatic alarm responses.

Dirty Controller Test Procedure

1. Press the controller’s test/reset switch for two seconds.
2. Verify that the controller’s Trouble LED flashes.

DIRTY SENSOR TEST

The dirty sensor test provides an indication of the sensor’s ability to compensate for gradual environmental changes. A sensor that can no longer compensate for environmental changes is considered 100% dirty and requires cleaning or replacing. Use a field provided SD-MAG test magnet to initiate a sensor dirty test. The sensor’s Dirty LED indicates the results of the dirty test as shown in Table 6.

NOTICE: OPERATIONAL TEST NOTICE

Failure to follow this NOTICE may result in an unnecessary evacuation of the facility.

Holding the test magnet against the sensor housing for more than seven seconds will put the duct detector into the alarm state and activate all automatic alarm responses.

Table 6 — Dirty LED Test

FLASHES	DESCRIPTION
1	0-25% dirty. (Typical of a newly installed detector)
2	25-50% dirty
3	51-75% dirty
4	76-99% dirty

Dirty Sensor Test Procedure

1. Hold the test magnet where indicated on the side of the sensor housing for two seconds.
2. Verify that the sensor’s Dirty LED flashes.

NOTICE: OPERATIONAL TEST NOTICE

Failure to follow this NOTICE may result in an unnecessary evacuation of the facility.

Changing the dirty sensor test operation will put the detector into the alarm state and activate all automatic alarm responses. Before changing dirty sensor test operation, disconnect all auxiliary equipment from the controller and notify the proper authorities if connected to a fire alarm system.

CHANGING THE DIRT SENSOR TEST

By default, sensor dirty test results are indicated by:

- The sensor’s Dirty LED flashing.
- The controller’s Trouble LED flashing.
- The controller’s supervision relay contacts toggle.

The operation of a sensor’s dirty test can be changed so that the controller’s supervision relay is not used to indicate test results. When two detectors are connected to a controller, sensor dirty test operation on both sensors must be configured to operate in the same manner.

To Configure the Dirty Sensor Test Operation

1. Hold the test magnet where indicated on the side of the sensor housing for approximately 60 seconds until the sensor’s Alarm LED turns on and its Dirty LED flashes twice.
2. Reset the sensor by removing the test magnet and then holding it against the sensor housing again for approximately 2 seconds until the sensor’s Alarm LED turns off.

REMOTE STATION TEST

The remote station alarm test checks a test/reset station’s ability to initiate and indicate an alarm state.

NOTICE: OPERATIONAL TEST NOTICE

Failure to follow this NOTICE may result in an unnecessary evacuation of the facility.

Changing the dirty sensor test operation will put the detector into the alarm state and activate all automatic alarm responses. Before changing the dirty sensor test operation, disconnect all auxiliary equipment from the controller and notify proper authorities if connected to a fire alarm system.

SD-TRK4 REMOTE ALARM TEST PROCEDURE

1. Turn the key switch to the RESET/TEST position for seven seconds.
2. Verify that the test/reset station’s Alarm LED turns on.
3. Reset the sensor by turning the key switch to the RESET/TEST position for two seconds.
4. Verify that the test/reset station’s Alarm LED turns off.

REMOTE TEST/RESET STATION DIRTY SENSOR TEST

The test/reset station dirty sensor test checks the test/reset station’s ability to initiate a sensor dirty test and indicate the results. It must

be wired to the controller as shown in Fig. 42 and configured to operate the controller’s supervision relay. For more information, see “Changing the Dirty Sensor Test.”

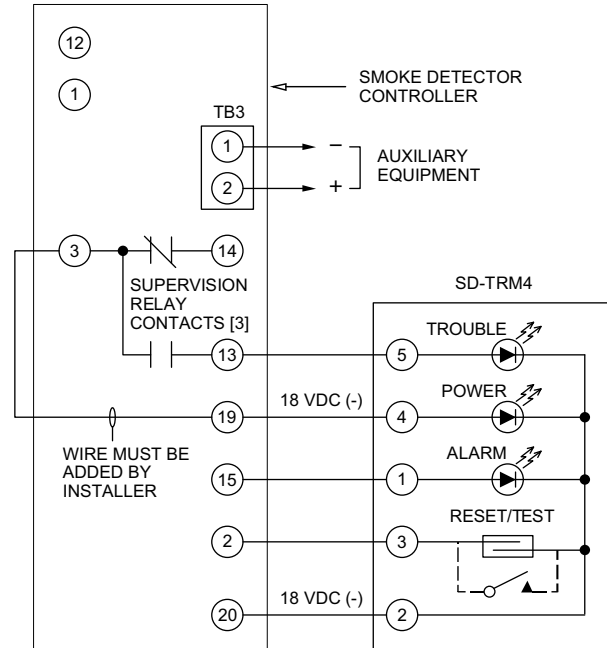

Fig. 42 — Remote Test/Reset Station Connections

NOTICE: OPERATIONAL TEST NOTICE

Failure to follow this NOTICE can result in an unnecessary evacuation of the facility.

If the test/reset station’s key switch is left in the RESET/TEST position for longer than seven seconds, the detector will automatically go into the alarm state and activate all automatic alarm responses.

NOTICE: OPERATIONAL TEST NOTICE

Failure to follow this NOTICE can result in an unnecessary evacuation of the facility.

Holding the test magnet to the target area for longer than seven seconds will put the detector into the alarm state and activate all automatic alarm responses.

DIRTY SENSOR TEST USING AN SD-TRK4

1. Turn the key switch to the RESET/TEST position for two seconds.
2. Verify that the test/reset station’s Trouble LED flashes.

Detector Cleaning

CLEANING THE SMOKE DETECTOR

Clean the duct smoke sensor when the Dirty LED is flashing continuously or sooner, if conditions warrant.

NOTICE: OPERATIONAL TEST NOTICE

Failure to follow this NOTICE can result in an unnecessary evacuation of the facility.

If the smoke detector is connected to a fire alarm system, first notify the proper authorities that the detector is undergoing maintenance then disable the relevant circuit to avoid generating a false alarm.

1. Disconnect power from the duct detector then remove the sensor’s cover. (See Fig. 43.)

2. Using a vacuum cleaner, clean compressed air, or a soft bristle brush, remove loose dirt and debris from inside the sensor housing and cover. Use isopropyl alcohol and a lint-free cloth to remove dirt and other contaminants from the gasket on the sensor's cover.
3. Squeeze the retainer clips on both sides of the optic housing then lift the housing away from the printed circuit board.
4. Gently remove dirt and debris from around the optic plate and inside the optic housing.
5. Replace the optic housing and sensor cover.
6. Connect power to the duct detector then perform a sensor alarm test.

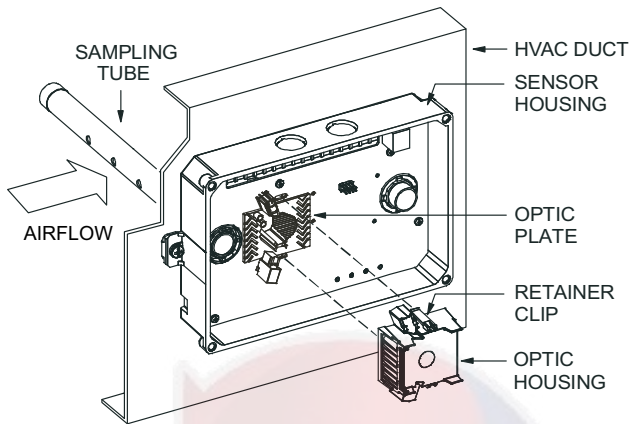

Fig. 43 — Sensor Cleaning Diagram

INDICATORS

Normal State

The smoke detector operates in the normal state in the absence of any trouble conditions and when its sensing chamber is free of smoke. In the normal state, the Power LED on both the sensor and the controller are on and all other LEDs are off.

Alarm State

The smoke detector enters the alarm state when the amount of smoke particulate in the sensor's sensing chamber exceeds the alarm threshold value. (See Table 7.) Upon entering the alarm state:

- The sensor's Alarm LED and the controller's Alarm LED turn on.
- The contacts on the controller's two auxiliary relays switch positions.

- The contacts on the controller's alarm initiation relay close.
- The controller's remote alarm LED output is activated (turned on).
- The controller's high impedance multiple fan shutdown control line is pulled to ground Trouble state.

The SuperDuct duct smoke detector enters the trouble state under the following conditions:

- A sensor's cover is removed and 20 minutes pass before it is properly secured.
- A sensor's environmental compensation limit is reached (100% dirty).
- A wiring fault between a sensor and the controller is detected.

An internal sensor fault is detected upon entering the trouble state:

- The contacts on the controller's supervisory relay switch positions. (See Fig. 44.)
- If a sensor trouble, the sensor's Trouble LED the controller's Trouble LED turn on.
- If 100% dirty, the sensor's Dirty LED turns on and the controller's Trouble LED flashes continuously.
- If a wiring fault between a sensor and the controller, the controller's Trouble LED turns on but not the sensor's.

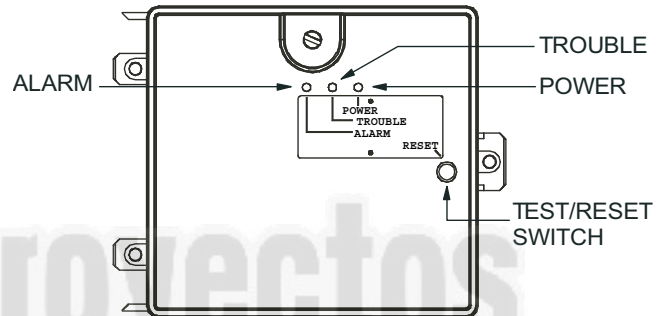

Fig. 44 — Controller Assembly

NOTE: All troubles are latched by the duct smoke detector. The trouble condition must be cleared and then the duct smoke detector must be reset in order to restore it to the normal state.

Table 7 — Detector Indicators

CONTROL OR INDICATOR	DESCRIPTION
Magnetic test/reset switch	Resets the sensor when it is in the alarm or trouble state. Activates or tests the sensor when it is in the normal state.
Alarm LED	Indicates the sensor is in the alarm state.
Trouble LED	Indicates the sensor is in the trouble state.
Dirty LED	Indicates the amount of environmental compensation used by the sensor (flashing continuously = 100%)
Power LED	Indicates the sensor is energized.

Resetting Alarm and Trouble Condition Trips

Manual reset is required to restore smoke detector systems to Normal operation. For installations using two sensors, the duct smoke detector does not differentiate which sensor signals an alarm or trouble condition. Check each sensor for Alarm or Trouble status. Clear the condition that has generated the trip at this sensor. Then reset the sensor by pressing and holding the reset button (on the side) for 2 seconds. Verify that the sensor's Alarm and Trouble LEDs are now off. At the controller, clear its Alarm or Trouble state by pressing and holding the manual reset button (on the front cover) for 2 seconds. Verify that the controller's Alarm and Trouble LEDs are now off. Replace all panels.

Troubleshooting

CONTROLLER'S TROUBLE LED IS ON

1. Check the Trouble LED on each sensor connected to the controller. If a sensor's Trouble LED is on, determine the cause and make the necessary repairs.
2. Check the wiring between the sensor and the controller. If wiring is loose or missing, repair or replace as required.

CONTROLLER'S TROUBLE LED IS FLASHING

1. One or both of the sensors is 100% dirty.
2. Determine which Dirty LED is flashing then clean that sensor assembly as described in the detector cleaning section.

SENSOR'S TROUBLE LED IS ON

1. Check the sensor's Dirty LED. If it is flashing, the sensor is dirty and must be cleaned.
2. Check the sensor's cover. If it is loose or missing, secure the cover to the sensor housing.
3. Replace sensor assembly.

SENSOR'S POWER LED IS OFF

1. Check the controller's Power LED. If it is off, determine why the controller does not have power and make the necessary repairs.
2. Check the wiring between the sensor and the controller. If wiring is loose or missing, repair or replace as required.

CONTROLLER'S POWER LED IS OFF

1. Make sure the circuit supplying power to the controller is operational. If not, make sure JP2 and JP3 are set correctly on the controller before applying power.
2. Verify that power is applied to the controller's supply input terminals. If power is not present, replace or repair wiring as required.

REMOTE TEST/RESET STATION'S TROUBLE LED DOES NOT FLASH WHEN PERFORMING A DIRTY TEST, BUT THE CONTROLLER'S TROUBLE LED DOES

1. Verify that the remote test/station is wired as shown in Fig. 42. Repair or replace loose or missing wiring.
2. Configure the sensor dirty test to activate the controller's supervision relay. See "Changing Sensor Dirty Test Operation."

SENSOR'S TROUBLE LED IS ON, BUT THE CONTROLLER'S TROUBLE LED IS OFF

Remove JP1 on the controller.

PROTECTIVE DEVICES

Compressor Protection

OVERCURRENT

The compressor has internal linebreak motor protection. Reset is automatic after compressor motor has cooled.

OVERTEMPERATURE

Each compressor has an internal protector to protect it against excessively high discharge gas temperatures. Reset is automatic.

HIGH PRESSURE SWITCH

The system is provided with a high pressure switch mounted on the discharge line. The switch is stem-mounted and brazed into the discharge tube. Trip setting is 630 psig \pm 10 psig (4344 \pm 69 kPa) when hot. Reset is automatic at 505 psig (3482 kPa).

LOW PRESSURE SWITCH

The system is protected against a loss of charge and low evaporator coil loading condition by a low pressure switch located on the suction line near the compressor. The switch is stem-mounted. Trip setting is 54 psig \pm 5 psig (372 \pm 34 kPa). Reset is automatic at 117 \pm 5 psig (807 \pm 34 kPa).

SUPPLY (INDOOR) FAN MOTOR PROTECTION

⚠ CAUTION

PERSONAL INJURY HAZARD

Failure to follow this caution can result in personal injury.

Disconnect all electrical power when servicing the fan motor. Apply appropriate lockout/tag-out procedures.

Motors with 2.9 and 3.7 bhp are equipped with an internal overtemperature or protection device. The type of device depends on the motor size. See Table 8.

The high static option supply fan motor is equipped with a pilot-circuit Thermix combination overtemperature/overcurrent protection device. This device resets automatically. Do not bypass this switch to correct trouble. Determine the cause and correct it.

The Thermik device is a snap-action overtemperature protection device that is embedded in the motor windings. The Thermik can be identified by two blue wires extending out of the motor control box. It is a pilot-circuit device that is wired into the unit's 24-v control circuit. When this switch reaches its trip setpoint, it opens the 24-v control circuit and causes all unit operation to cease. This device resets automatically when the motor windings cool. Do not bypass this switch to correct trouble. Determine the cause and correct it.

The external overload breaker is an overcurrent device used on motors with a horsepower rating of 4.7 hp or greater. This is a specially-calibrated circuit breaker that is UL recognized as a motor overload controller. When the current to the motor exceeds the circuit breaker setpoint, the device opens all motor power leads to the motor, shutting the motor down. Reset requires a manual reset at the overload switch. This device (designated IFCB) is located on the side of the supply fan housing, behind the fan access panel. The must hold and must trip values are listed on the side of the external overload breaker.

Table 8 — Overcurrent Device Type

MOTOR SIZE (bhp)	OVERLOAD DEVICE	RESET
1.7	Internal Linebreak	Automatic
2.4	Internal Linebreak	Automatic
2.9	Thermik	Automatic
3.7	Thermik	Automatic
4.7	External (circuit breaker)	Manual

TROUBLESHOOTING SUPPLY FAN MOTOR OVERLOAD TRIPS

The supply fan used in 50TC units is a forward-curved centrifugal wheel. At a constant wheel speed, this wheel has a characteristic that causes the fan shaft load to DECREASE when the static pressure in the unit-duct system increases and to INCREASE when the static pressure in the unit-duct system decreases (and fan airflow rate increases). Motor overload conditions typically develop when the unit is operated with an access panel removed, with unfinished duct work, in an economizer-open mode, or a leak develops in the duct system that allows a bypass back to unit return opening.

CONDENSER FAN MOTOR PROTECTION

The condenser fan motor is internally protected against overtemperature.

Control Circuit, 24v

The control circuit is protected against overcurrent conditions by a circuit breaker mounted on the control transformer TRAN. Reset is manual.

The factory-installed PremierLink Controller includes the supply-air temperature (SAT) sensor. The outdoor air temperature (OAT) sensor is included in the FIOP/accessory EconoMiSer 2 package.

NOTE: Refer to PremierLink Installation, Start-Up and Configuration Instructions. Have a copy of this manual available at unit start-up.

PremierLink™ Control

For details on operating units equipped with the factory-installed PremierLink controller option, refer to the *PremierLink Retrofit Rooftop Controller Version 3.x Installation, Start-Up, and Configuration Instructions* manual.

RTU Open Control System

For details on operating units equipped with the factory-installed RTU Open controller, refer to the *Factory-Installed RTU Open Multi-Protocol Controller Control, Start-Up, Operation and Troubleshooting* manual.

ECONOMISER SYSTEMS

IMPORTANT: Any economizer that meets the economizer requirements as laid out in California's Title 24 mandatory section 120.2 (fault detection and diagnostics) and/or prescriptive section 140.4 (life-cycle tests, damper leakage, 5 year warranty, sensor accuracy, etc), will have a label on the economizer. Any economizer without this label does not meet California's Title 24. The five-year limited parts warranty referred to in section 140.4 only applies to factory installed economizers. Please refer to the economizer on the unit.

The 50TC units may be equipped with a factory-installed or accessory (field-installed) EconoMiSer system. Three types are available: with a logic control system (EconoMiSer IV and EconoMiSer X) and without a control system (EconoMiSer2). See Fig. 45-47 for component locations on each type. The W7212 controller is used for EconoMiSer IV and the W7220 controller is used for EconoMiSer X. See Fig. 48-51 for EconoMiSer section wiring diagrams.

All three EconoMiSer system use direct-drive damper actuators.

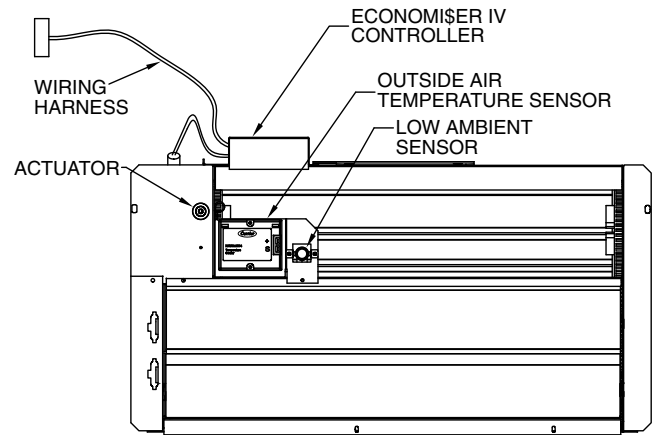

Fig. 45 — EconoMiSer IV Component Locations

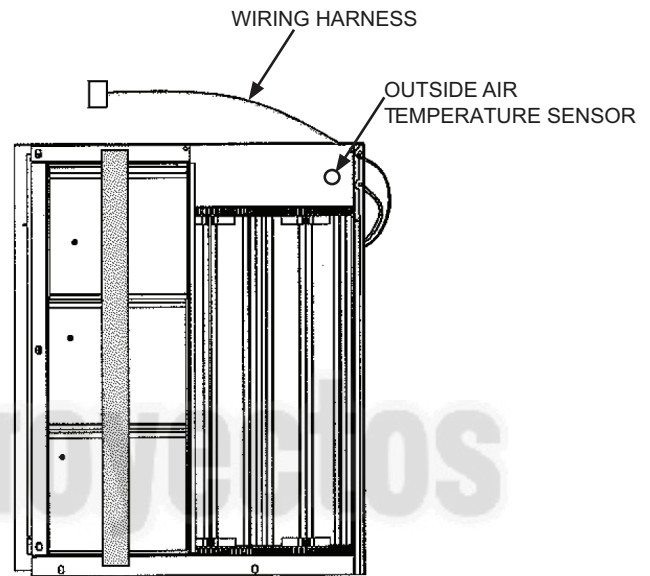

Fig. 46 — EconoMiSer X Component Locations

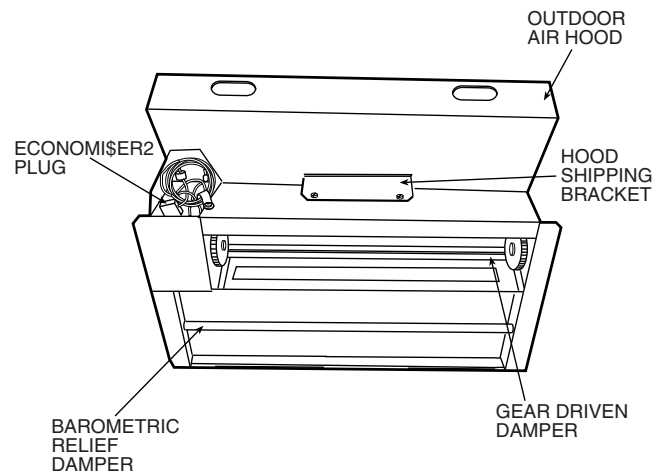

Fig. 47 — EconoMiSer 2 Component Locations

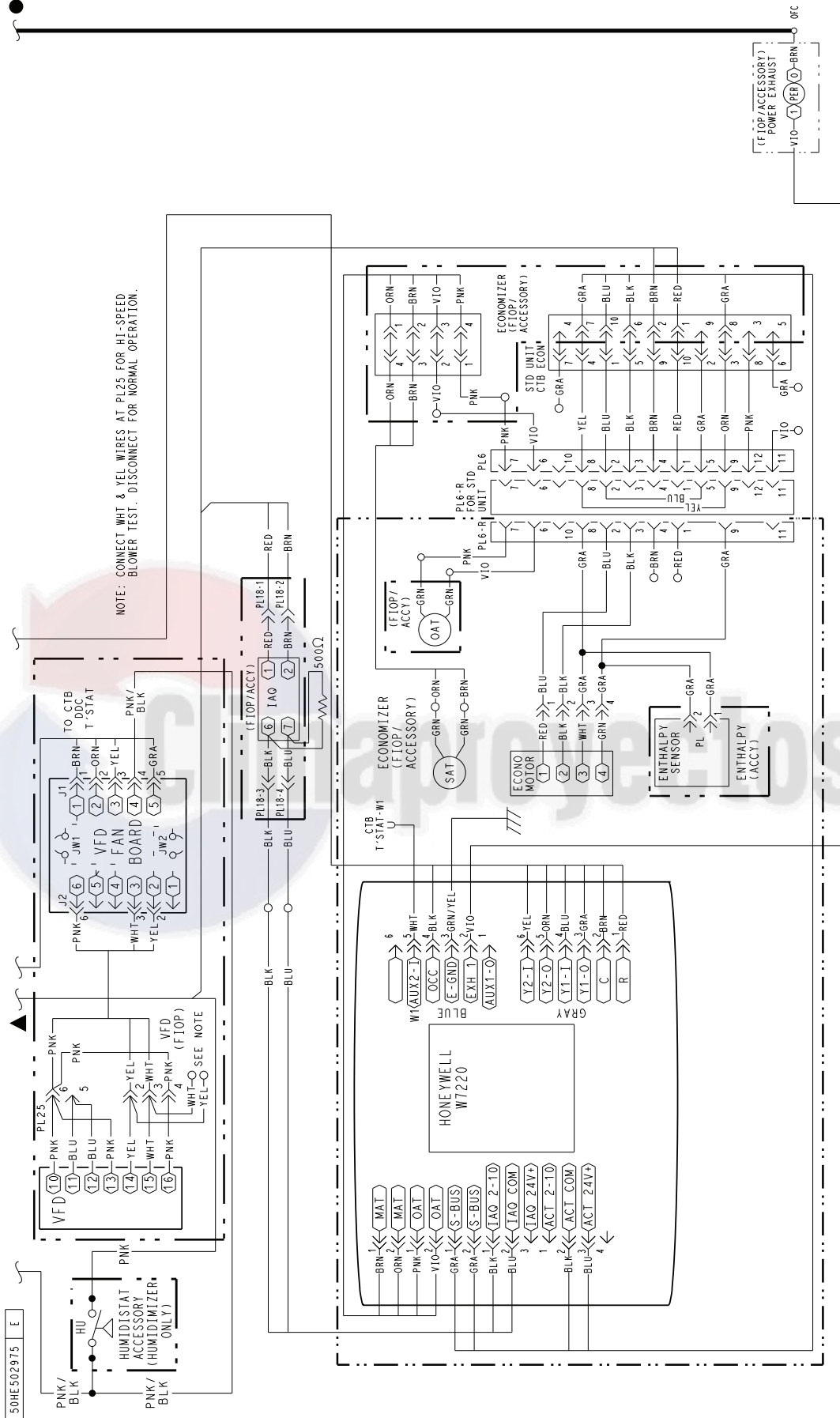
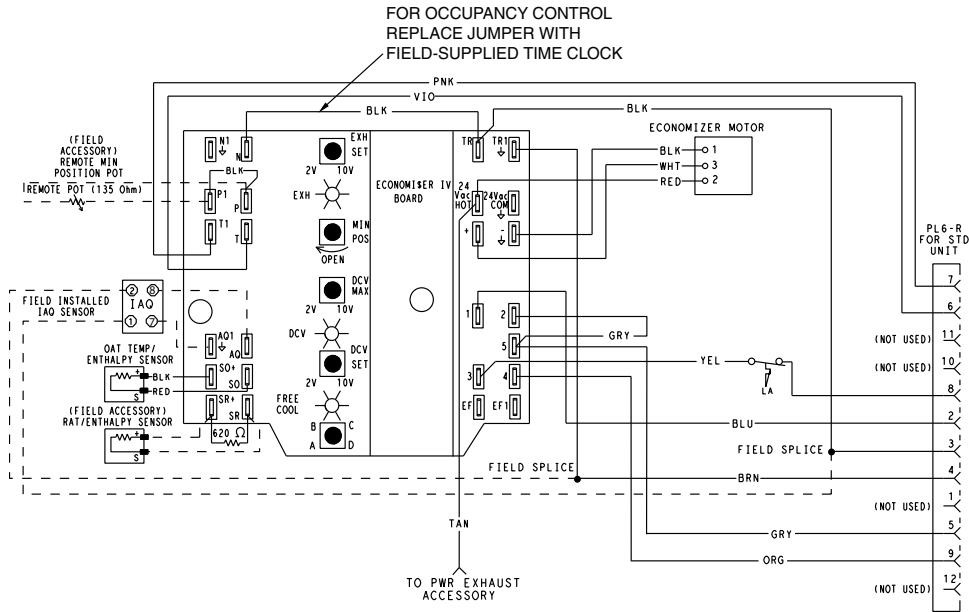

Fig. 49 — VFD Overlay for W2770 Controller Wiring



LEGEND

- DCV** — Demand Controlled Ventilation
- IAQ** — Indoor Air Quality
- LA** — Low Ambient Lockout Device
- OAT** — Outdoor Air Temperature
- POT** — Potentiometer
- RAT** — Return Air Temperature

- Potentiometer
Power Exhaust
Minimum Pos.
DCV Max.
DCV Set
Enthalpy
- Defaults Settings:
Middle
Fully Closed
Middle
Middle
C Setting

NOTES:

1. 620 ohm, 1 watt 5% resistor should be removed only when using differential enthalpy or dry bulb.
2. If a separate field-supplied 24 v transformer is used for the IAQ sensor power supply, it cannot have the secondary of the transformer grounded.
3. For field-installed remote minimum position POT, remove black wire jumper between P and P1 and set control minimum position POT to the minimum position.

Fig. 50 — EconoMiSer IV Wiring

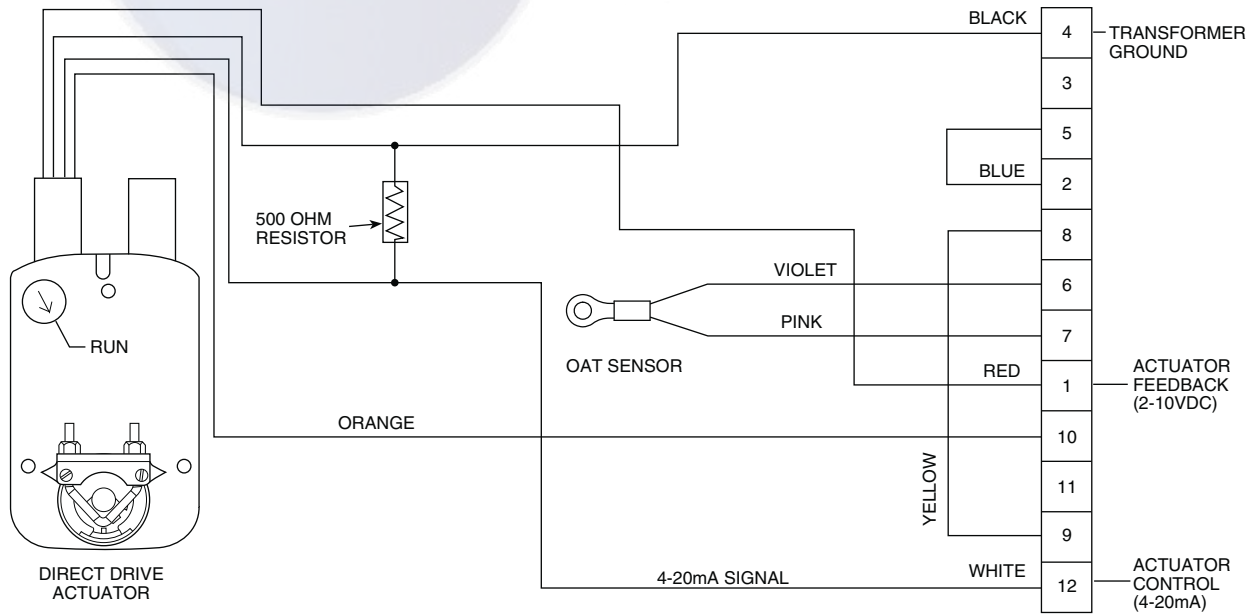

ECONOMISER2 PLUG

NOTES:

1. Switch on actuator must be in run position for economizer to operate.

2. PremierLink™ control requires that the standard 50HJ540569 outside-air sensor be replaced by either the CROASENR001A00 dry bulb sensor or HH57A077 enthalpy sensor.
3. 50HJ540573 actuator consists of the 50HJ540567 actuator and a harness with 500-ohm resistor.

Fig. 51 — EconoMiSer2 with 4 to 20 mA Control Wiring

EconoMi\$er IV Standard Sensors

Table 9 provides a summary of EconoMi\$er IV Logic. A functional view of the EconoMi\$er is shown in Fig. 52. Typical settings, sensor ranges, and jumper positions are also shown. An EconoMi\$er IV simulator program is available from Carrier to help with EconoMi\$er IV system training and troubleshooting.

OUTDOOR AIR TEMPERATURE (OAT) SENSOR

The outdoor air temperature sensor (HH57AC074) is a 10 to 20 mA device used to measure the outdoor-air temperature. The outdoor-air temperature is used to determine when the EconoMi\$er IV system can be used for free cooling. The sensor is factory-installed on the EconoMi\$er IV in the outdoor airstream. (See Fig. 53.) The operating range of temperature measurement is 40°F to 100°F (4°C to 38°C). See Fig. 54.

Table 9 — EconoMi\$er IV Input/Output Logic

Demand Controlled Ventilation (DCV)	INPUTS				OUTPUTS			
	Enthalpy*		Y1	Y2	Compressor		N Terminal†	
	Outdoor	Return			Stage 1	Stage 2	Occupied	Unoccupied
							Damper	
Below set (DCV LED off)	High (Free Cooling LED off)	Low	On	On	On	On	Minimum position	Closed
			On	Off	On	Off		
			Off	Off	Off	Off		
	Low (Free Cooling LED on)	High	On	On	On	Off	Modulating** (between min. position and full-open)	Modulating** (between closed and full-open)
			On	Off	Off	Off		
			Off	Off	Off	Off		
Above set (DCV LED on)	High (Free Cooling LED off)	Low	On	On	On	On	Modulating†† (between min. position and DCV maximum)	Modulating†† (between closed and DCV maximum)
			On	Off	On	Off		
			Off	Off	Off	Off		
	Low (Free Cooling LED on)	High	On	On	On	Off	Modulating***	Modulating†††
			On	Off	Off	Off		
			Off	Off	Off	Off		

*For single enthalpy control, the module compares outdoor enthalpy to the ABCD set point.
 †Power at N terminal determines Occupied/Unoccupied setting: 24 vac (Occupied), no power (Unoccupied).
 **Modulation is based on the supply-air sensor signal.
 ††Modulation is based on the DCV signal.

*** Modulation is based on the greater of DCV and supply-air sensor signals, between minimum position and either maximum position (DCV) or fully open (supply-air signal).
 ††† Modulation is based on the greater of DCV and supply-air sensor signals, between closed and either maximum position (DCV) or fully open (supply-air signal).

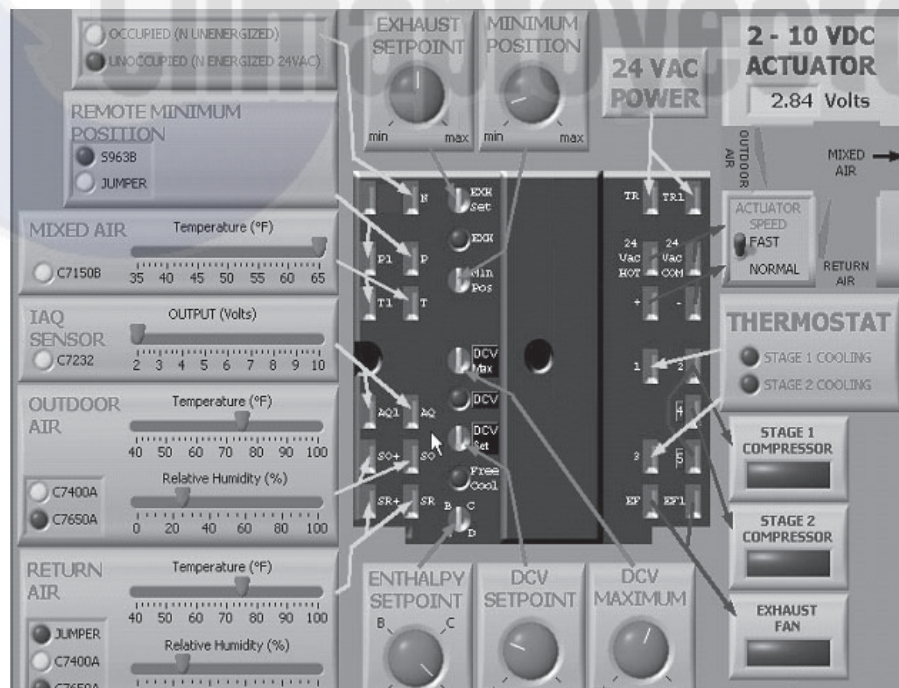

Fig. 52 — EconoMi\$er IV Functional View

SUPPLY AIR TEMPERATURE (SAT) SENSOR

The supply air temperature sensor is a 3 K thermistor located at the inlet of the indoor fan. (See Fig. 53.) This sensor is factory installed. The operating range of temperature measurement is 0°F to 158°F (-18°C to 70°C).

The temperature sensor looks like an eyelet terminal with wires running to it. The sensor is located in the “crimp end” and is sealed from moisture.

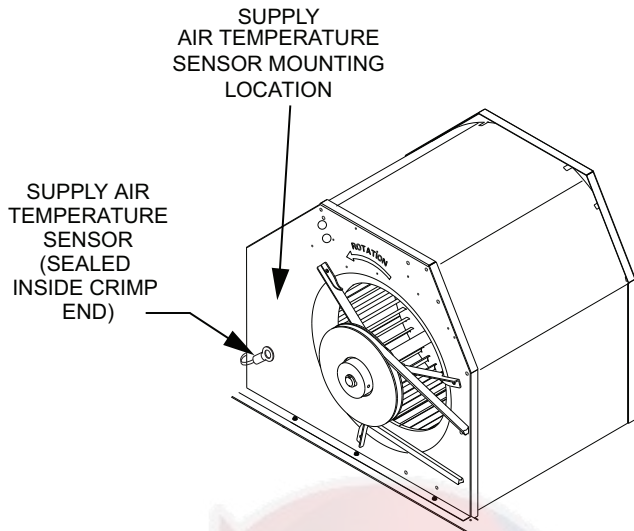

Fig. 53 — Supply Air Sensor Location

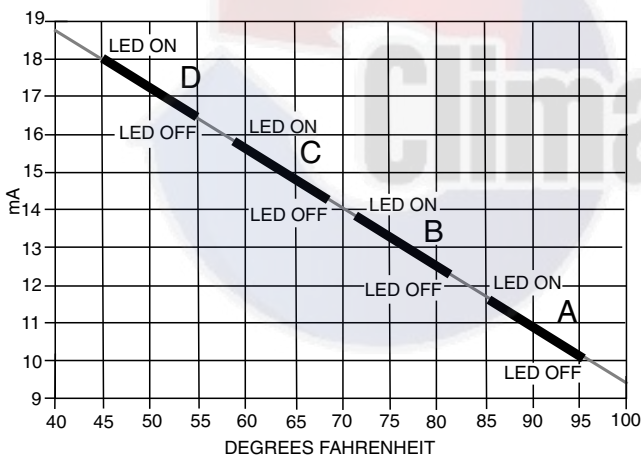

Fig. 54 — Outside Air Temperature Changeover Setpoints

OUTDOOR AIR LOCKOUT SENSOR

The EconoMiSer IV system is equipped with an ambient temperature lockout switch located in the outdoor airstream which is used to lock out the compressors below a 42°F (6°C) ambient temperature. (See Fig. 45.)

ECONOMISER IV CONTROL MODES

IMPORTANT: The optional EconoMiSer2 system does not include a controller. The EconoMiSer2 system is operated by a 4 to 20 mA signal from an existing field-supplied controller. See Fig. 47 for wiring information.

Determine the EconoMiSer IV control mode before set up of the control. Some modes of operation may require different sensors. (See Table 10.) The EconoMiSer IV system is supplied from the factory with a supply-air temperature sensor and an outdoor-air temperature sensor. This allows for operation of the EconoMiSer IV system with outdoor air dry bulb changeover control. Addition-

al accessories can be added to allow for different types of changeover control and operation of the EconoMiSer IV system and unit.

OUTDOOR DRY BULB CHANGEOVER

The standard controller is shipped from the factory configured for outdoor dry bulb changeover control. The outdoor air and supply air temperature sensors are included as standard. For this control mode, the outdoor temperature is compared to an adjustable setpoint selected on the control. If the outdoor-air temperature is above the setpoint, the EconoMiSer IV system will adjust the outside air dampers to minimum position. If the outdoor-air temperature is below the setpoint, the position of the outside air dampers will be controlled to provide free cooling using outdoor air. When in this mode, the LED next to the free cooling setpoint potentiometer will be on. The changeover temperature setpoint is controlled by the free cooling setpoint potentiometer located on the control. (See Fig. 54 and Fig. 55.) The scale on the potentiometer is A, B, C, and D. See Fig. 56 for the corresponding temperature changeover values.

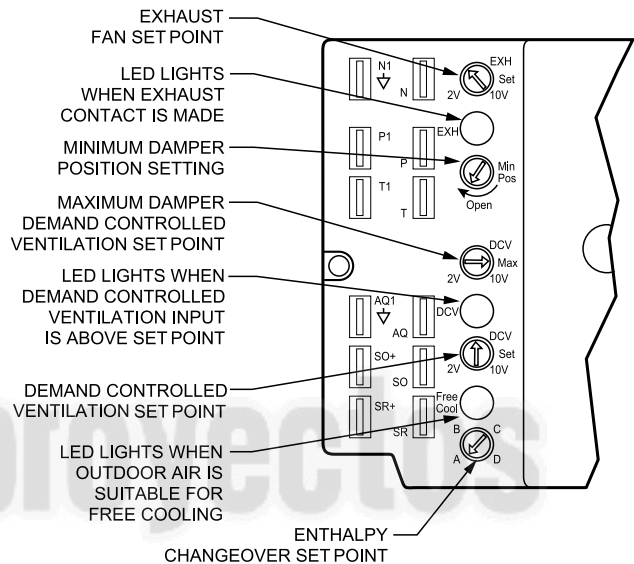

Fig. 55 — EconoMiSer IV Controller Potentiometer and LED Locations

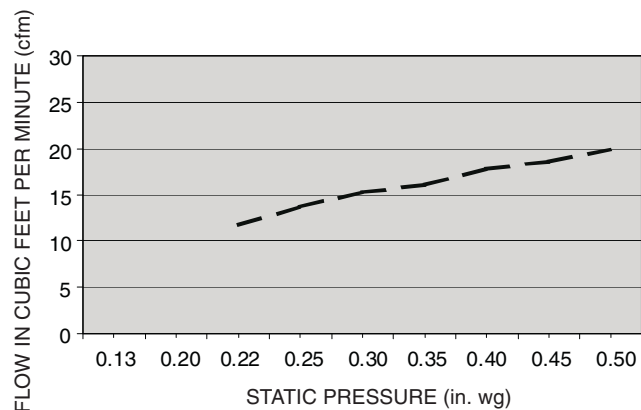

Fig. 56 — Outdoor-Air Damper Leakage

DIFFERENTIAL DRY BULB CONTROL

For differential dry bulb control, the standard outdoor dry bulb sensor is used in conjunction with an additional accessory dry bulb sensor (part number CRTEMPN002A00). The accessory sensor must be mounted in the return airstream. (See Fig. 57.) Wiring is provided in the EconoMiSer IV wiring harness.

In this mode of operation, the outdoor-air temperature is compared to the return-air temperature and the lower temperature airstream is used for cooling. When using this mode of changeover control,

turn the enthalpy setpoint potentiometer fully clockwise to the D setting. (See Fig. 55.)

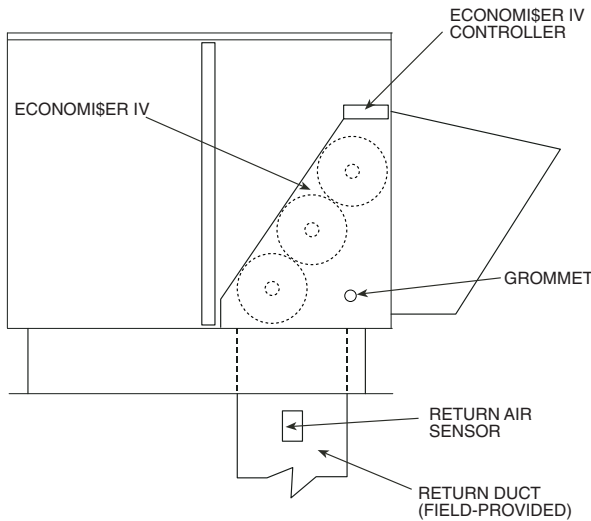

Fig. 57 — Return-Air Temperature or Enthalpy Sensor Mounting Location

OUTDOOR ENTHALPY CHANGEOVER

For enthalpy control, accessory enthalpy sensor (part number HH57AC078) is required. Replace the standard outdoor dry bulb temperature sensor with the accessory enthalpy sensor in the same mounting location. (See Fig. 57.) When the outdoor air enthalpy rises above the outdoor enthalpy changeover setpoint, the outdoor-air damper moves to its minimum position. The outdoor enthalpy changeover setpoint is set with the outdoor enthalpy setpoint potentiometer on the EconoMiSer IV controller. The setpoints are A, B, C, and D. (See Fig. 58.) The factory-installed 620-ohm jumper must be in place across terminals SR and SR+ on the EconoMiSer IV controller (see Fig. 59).

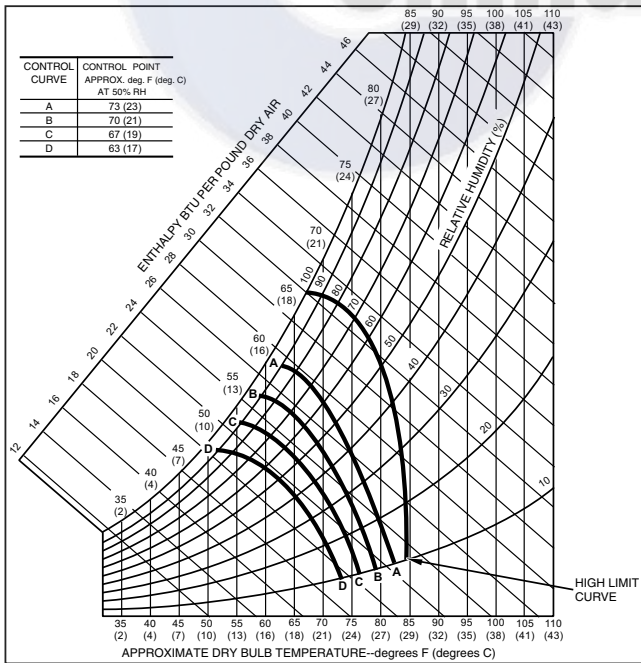

Fig. 58 — Enthalpy Changeover Setpoints

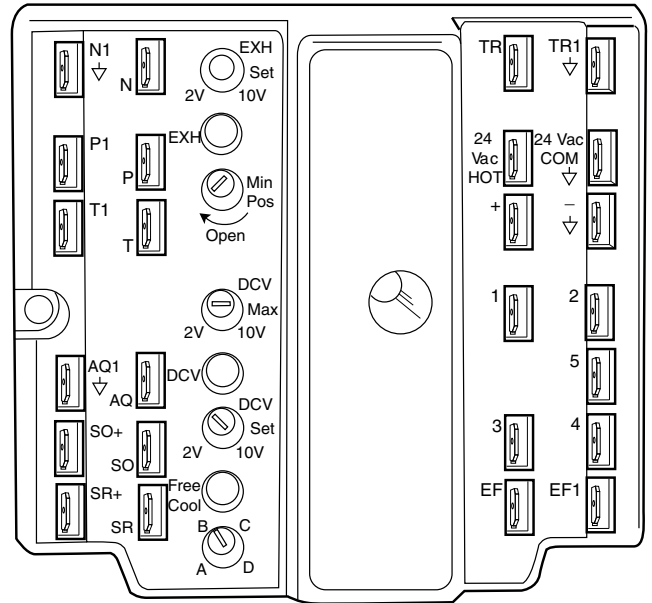

Fig. 59 — EconoMiSer IV Control

DIFFERENTIAL ENTHALPY CONTROL

For differential enthalpy control, the EconoMiSer IV controller uses two enthalpy sensors (HH57AC078 and CRENT-DIF004A00), one in the outside-air duct and one in the return-air duct. The EconoMiSer IV controller compares the outdoor air enthalpy to the return air enthalpy to determine EconoMiSer IV use. The controller selects the lower enthalpy air (return or outdoor) for cooling. For example, when the outdoor air has a lower enthalpy than the return air, the EconoMiSer IV opens to bring in outdoor air for free cooling.

Replace the standard outside air dry bulb temperature sensor with the accessory enthalpy sensor in the same mounting location. See Fig. 47. Mount the return air enthalpy sensor in the return air duct. See Fig. 57. Wiring is provided in the EconoMiSer IV wiring harness. See Fig. 50. The outdoor enthalpy changeover setpoint is set with the outdoor enthalpy setpoint potentiometer on the EconoMiSer IV controller. When using this mode of changeover control, turn the enthalpy setpoint potentiometer fully clockwise to the D setting.

INDOOR AIR QUALITY (IAQ) SENSOR INPUT

The IAQ input can be used for demand controlled ventilation control based on the level of CO₂ measured in the space or return air duct.

Mount the accessory IAQ sensor according to manufacturer specifications. The IAQ sensor should be wired to the AQ and AQ1 terminals of the controller. Adjust the DCV potentiometers to correspond to the DCV voltage output of the indoor air quality sensor at the user-determined setpoint. See Fig. 60.

If a separate field-supplied transformer is used to power the IAQ sensor, the sensor must not be grounded or the EconoMiSer IV control board will be damaged.

When using demand controlled ventilation, the minimum damper position represents the minimum ventilation position for VOC (volatile organic compounds) ventilation requirements. The maximum demand ventilation position is used for fully occupied ventilation.

When demand controlled ventilation is not being used, the minimum position potentiometer should be used to set the occupied ventilation position. The maximum demand ventilation position should be turned fully clockwise.

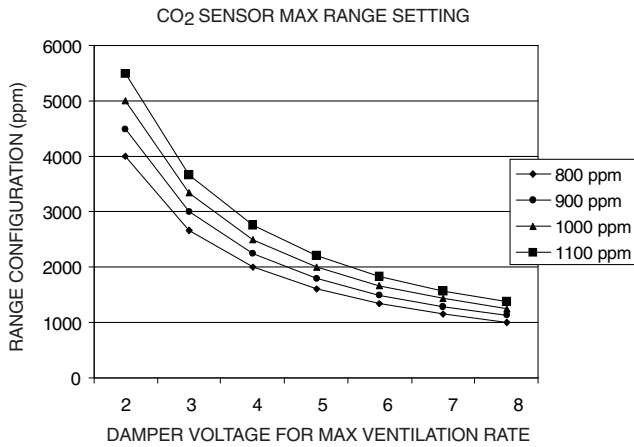

Fig. 60 — CO₂ Sensor Maximum Range Settings

EXHAUST SETPOINT ADJUSTMENT

The exhaust setpoint will determine when the exhaust fan runs based on damper position (if accessory power exhaust is installed). The setpoint is modified with the Exhaust Fan Setpoint (EXH SET) potentiometer. See Fig. 55. The setpoint represents the damper position above which the exhaust fans will be turned on. When there is a call for exhaust, the EconoMiSer IV controller provides a 45 ± 15 second delay before exhaust fan activation to allow the dampers to open. This delay allows the damper to reach the appropriate position to avoid unnecessary fan overload.

MINIMUM POSITION CONTROL

There is a minimum damper position potentiometer on the EconoMiSer IV controller. See Fig. 55. The minimum damper position maintains the minimum airflow into the building during the occupied period.

When using demand ventilation, the minimum damper position represents the minimum ventilation position for Volatile Organic Compound (VOC) ventilation requirements. The maximum demand ventilation position is used for fully occupied ventilation.

When demand ventilation control is not being used, the minimum position potentiometer should be used to set the occupied ventilation position. The maximum demand ventilation position should be turned fully clockwise.

Adjust the minimum position potentiometer to allow the minimum amount of outdoor air, as required by local codes, to enter the building. Make minimum position adjustments with at least 10°F temperature difference between the outdoor and return-air temperatures.

To determine the minimum position setting, perform the following procedure:

1. Calculate the appropriate mixed air temperature using the following formula:

$$\left(T_O \times \frac{OA}{100} \right) + \left(T_R \times \frac{RA}{100} \right) = T_M$$

T_O = Outdoor-Air Temperature

OA = Percent of Outdoor Air

T_R = Return-Air Temperature

RA = Percent of Return Air

T_M = Mixed-Air Temperature

As an example, if local codes require 10% outdoor air during occupied conditions, outdoor-air temperature is 60°F, and return-air temperature is 75°F.

$$(60 \times 0.10) + (75 \times 0.90) = 73.5^\circ\text{F}$$

2. Disconnect the supply air sensor from terminals T and T1.

3. Ensure that the factory-installed jumper is in place across terminals P and P1. If remote damper positioning is being used, make sure that the terminals are wired according to Fig. 54 and that the minimum position potentiometer is turned fully clockwise.
4. Connect 24 vac across terminals TR and TR1.
5. Carefully adjust the minimum position potentiometer until the measured mixed air temperature matches the calculated value.
6. Reconnect the supply air sensor to terminals T and T1.

Remote control of the EconoMiSer IV damper is desirable when requiring additional temporary ventilation. If a field-supplied remote potentiometer (Honeywell part number S963B1128) is wired to the EconoMiSer IV controller, the minimum position of the damper can be controlled from a remote location.

To control the minimum damper position remotely, remove the factory-installed jumper on the P and P1 terminals on the EconoMiSer IV controller. Wire the field-supplied potentiometer to the P and P1 terminals on the EconoMiSer IV controller. (See Fig. 58.)

DAMPER MOVEMENT

Damper movement from full open to full closed (or vice versa) takes 2½ minutes.

THERMOSTATS

The EconoMiSer IV control works with conventional thermostats that have a Y1 (cool stage 1), Y2 (cool stage 2), W1 (heat stage 1), W2 (heat stage 2), and G (fan). The EconoMiSer IV control does not support space temperature sensors. Connections are made at the thermostat terminal connection board located in the main control box.

OCCUPANCY CONTROL

The factory default configuration for the EconoMiSer IV control is occupied mode. Occupied status is provided by the black jumper from terminal TR to terminal N. When unoccupied mode is desired, install a field-supplied timeclock function in place of the jumper between TR and N. When the timeclock contacts are closed, the EconoMiSer IV control will be in occupied mode. When the timeclock contacts are open (removing the 24-v signal from terminal N), the EconoMiSer IV system will be in unoccupied mode.

DEMAND CONTROLLED VENTILATION (DCV)

When using the EconoMiSer IV system for demand controlled ventilation, there are some equipment selection criteria which should be considered. When selecting the heat capacity and cool capacity of the equipment, the maximum ventilation rate must be evaluated for design conditions. The maximum damper position must be calculated to provide the desired fresh air.

Typically the maximum ventilation rate will be about 5 to 10% more than the typical cfm required per person, using normal outside air design criteria.

A proportional anticipatory strategy should be taken with the following conditions: a zone with a large area, varied occupancy, and equipment that cannot exceed the required ventilation rate at design conditions. Exceeding the required ventilation rate means the equipment can condition air at a maximum ventilation rate that is greater than the required ventilation rate for maximum occupancy. A proportional-anticipatory strategy will cause the fresh air supplied to increase as the room CO₂ level increases even though the CO₂ setpoint has not been reached. By the time the CO₂ level reaches the setpoint, the damper will be at maximum ventilation and should maintain the setpoint.

In order to have the CO₂ sensor control the EconoMiSer IV damper in this manner, first determine the damper voltage output for minimum or base ventilation. Base ventilation is the ventilation required to remove contaminants during unoccupied periods. The

following equation may be used to determine the percent of outside air entering the building for a given damper position. For best results, there should be at least a 10°F difference in outside-air and return-air temperatures.

$$(T_O \times \frac{OA}{100}) + (T_R \times \frac{RA}{100}) = T_M$$

T_O = Outdoor-Air Temperature

OA = Percent of Outdoor Air

T_R = Return-Air Temperature

RA = Percent of Return Air

T_M = Mixed-Air Temperature

Once base ventilation has been determined, set the minimum damper position potentiometer to the correct position.

The same equation can be used to determine the occupied or maximum ventilation rate to the building. For example, an output of 3.6 volts to the actuator provides a base ventilation rate of 5% and an output of 6.7 volts provides the maximum ventilation rate of 20% (or base plus 15 cfm per person). Use Fig. 60 to determine the maximum setting of the CO₂ sensor. For example, an 1100 ppm setpoint relates to a 15 cfm per person design. Use the 1100 ppm curve on Fig. 60 to find the point when the CO₂ sensor output will be 6.7 volts. Line up the point on the graph with the left side of the chart to determine that the range configuration for the CO₂ sensor should be 1800 ppm. The EconoMiSer IV controller will output the 6.7 volts from the CO₂ sensor to the actuator when the CO₂ concentration in the space is at 1100 ppm. The DCV setpoint may be left at 2 volts since the CO₂ sensor voltage will be ignored by the EconoMiSer IV controller until it rises above the 3.6 volt setting of the minimum position potentiometer.

Once the fully occupied damper position has been determined, set the maximum damper demand control ventilation potentiometer to this position. Do not set to the maximum position, as this can result in over-ventilation to the space and potential high humidity levels.

CO₂ SENSOR CONFIGURATION

The CO₂ sensor has preset standard voltage settings that can be selected anytime after the sensor is powered up. See Table 10.

Use setting 1 or 2 for Carrier equipment. See Table 10.

1. Press Clear and Mode buttons. Hold at least 5 seconds until the sensor enters the Edit mode.
2. Press Mode twice. The STDSET Menu will appear.
3. Use the Up/Down button to select the preset number. (See Table 10.)
4. Press Enter to lock in the selection.
5. Press Mode to exit and resume normal operation.

Table 10 — EconoMiSer IV Sensor Usage

APPLICATION	ECONOMISER IV WITH OUTDOOR-AIR DRY BULB SENSOR		
	Accessories Required		
Outdoor Air Dry Bulb	None. The outdoor air dry bulb sensor is factory installed.		
Differential Dry Bulb	CRTEMPSN002A00*		
Single Enthalpy	HH57AC078		
Differential Enthalpy	HH57AC078 and CRENTDIF004A00*		
CO ₂ for DCV Control using a Wall-Mounted CO ₂ Sensor	33ZCSENCO2		
CO ₂ for DCV Control using a Duct-Mounted CO ₂ Sensor	33ZCSENCO2† and 33ZCASPCO2**	OR	CRCBDIOX005A00††

* CRENTDIF004A00 and CRTEMPSN002A00 accessories are used on many different base units. As such, these kits may contain parts that will not be needed for installation.

† 33ZCSENCO2 is an accessory CO₂ sensor.

** 33ZCASPCO2 is an accessory aspirator box required for duct-mounted applications.

†† CRCBDIOX005A00 is an accessory that contains both 33ZCSENCO2 and 33ZCASPCO2 accessories.

The custom settings of the CO₂ sensor can be changed any time after the sensor is energized. Follow the steps below to change the non-standard settings:

1. Press Clear and Mode buttons. Hold at least 5 seconds until the sensor enters the Edit mode.
2. Press Mode twice. The STDSET Menu will appear.
3. Use the Up/Down button to toggle to the NONSTD menu and press Enter.
4. Use the Up/Down button to toggle through each of the nine variables, starting with Altitude, until the desired setting is reached.
5. Press Mode to move through the variables.
6. Press Enter to lock in the selection, then press Mode to continue to the next variable.

DEHUMIDIFICATION OF FRESH AIR WITH DCV (DEMAND CONTROLLED VENTILATION) CONTROL

If normal rooftop heating and cooling operation is not adequate for the outdoor humidity level, an energy recovery unit and/or a dehumidification option should be considered.

ECONOMISER IV PREPARATION

This procedure is used to prepare the EconoMiSer IV system for troubleshooting. No troubleshooting or testing is done by performing the following procedure.

NOTE: This procedure requires a 9-v battery, 1.2 kilo-ohm resistor, and a 5.6 kilo-ohm resistor, which are not supplied with the EconoMiSer IV system.

IMPORTANT: Be sure to record the positions of all potentiometers before starting troubleshooting.

1. Disconnect power at TR and TR1. All LEDs should be off. Exhaust fan contacts should be open.
2. Disconnect device at P and P1.
3. Jumper P to P1.
4. Disconnect wires at T and T1. Place 5.6 kilo-ohm resistor across T and T1.
5. Jumper TR to 1.
6. Jumper TR to N.

7. If connected, remove sensor from terminals SO and +. Connect 1.2 kilo-ohm 4074EJM checkout resistor across terminals SO and +.
8. Put 620-ohm resistor across terminals SR and +.
9. Set minimum position, DCV setpoint, and exhaust potentiometers fully CCW (counterclockwise).
10. Set DCV maximum position potentiometer fully CW (clockwise).
11. Set enthalpy potentiometer to D.
12. Apply power (24 vac) to terminals TR and TR1.

DIFFERENTIAL ENTHALPY

To check differential enthalpy:

1. Make sure EconoMiSer IV preparation procedure has been performed.
2. Place 620-ohm resistor across SO and +.
3. Place 1.2 kilo-ohm resistor across SR and +. The Free Cool LED should be lit.
4. Remove 620-ohm resistor across SO and +. The Free Cool LED should turn off.
5. Return EconoMiSer IV settings and wiring to normal after completing troubleshooting.

SINGLE ENTHALPY

To check single enthalpy:

1. Make sure EconoMiSer IV preparation procedure has been performed.
2. Set the enthalpy potentiometer to A (fully CCW). The Free Cool LED should be lit.
3. Set the enthalpy potentiometer to D (fully CW). The Free Cool LED should turn off.
4. Return EconoMiSer IV settings and wiring to normal after completing troubleshooting.

DCV (DEMAND CONTROLLED VENTILATION) AND POWER EXHAUST

To check DCV and Power Exhaust:

1. Make sure EconoMiSer IV preparation procedure has been performed.
2. Ensure terminals AQ and AQ1 are open. The LED for both DCV and Exhaust should be off. The actuator should be fully closed.
3. Connect a 9-v battery to AQ (positive node) and AQ1 (negative node). The LED for both DCV and Exhaust should turn on. The actuator should drive to between 90 and 95% open.
4. Turn the Exhaust potentiometer CW until the Exhaust LED turns off. The LED should turn off when the potentiometer is approximately 90%. The actuator should remain in position.
5. Turn the DCV setpoint potentiometer CW until the DCV LED turns off. The DCV LED should turn off when the potentiometer is approximately 9-v. The actuator should drive fully closed.
6. Turn the DCV and Exhaust potentiometers CCW until the Exhaust LED turns on. The exhaust contacts will close 30 to 120 seconds after the Exhaust LED turns on.
7. Return EconoMiSer IV settings and wiring to normal after completing troubleshooting.

DCV MINIMUM AND MAXIMUM POSITION

To check the DCV minimum and maximum position:

1. Make sure EconoMiSer IV preparation procedure has been performed.
2. Connect a 9-v battery to AQ (positive node) and AQ1 (negative node). The DCV LED should turn on. The actuator should drive to between 90 and 95% open.
3. Turn the DCV Maximum Position potentiometer to midpoint. The actuator should drive to between 20 and 80% open.
4. Turn the DCV Maximum Position potentiometer to fully CCW. The actuator should drive fully closed.
5. Turn the Minimum Position potentiometer to midpoint. The actuator should drive to between 20 and 80% open.
6. Turn the Minimum Position Potentiometer fully CW. The actuator should drive fully open.
7. Remove the jumper from TR and N. The actuator should drive fully closed.
8. Return EconoMiSer IV settings and wiring to normal after completing troubleshooting.

SUPPLY-AIR SENSOR INPUT

To check supply-air sensor input:

1. Make sure EconoMiSer IV preparation procedure has been performed.
2. Set the Enthalpy potentiometer to A. The Free Cool LED turns on. The actuator should drive to between 20 and 80% open.
3. Remove the 5.6 kilo-ohm resistor and jumper T to T1. The actuator should drive fully open.
4. Remove the jumper across T and T1. The actuator should drive fully closed.
5. Return EconoMiSer IV settings and wiring to normal after completing troubleshooting.

ECONOMISER IV TROUBLESHOOTING COMPLETION

This procedure is used to return the EconoMiSer IV system to operation. No troubleshooting or testing is done by performing the following procedure.

1. Disconnect power at TR and TR1.
2. Set enthalpy potentiometer to previous setting.
3. Set DCV maximum position potentiometer to previous setting.
4. Set minimum position, DCV setpoint, and exhaust potentiometers to previous settings.
5. Remove 620-ohm resistor from terminals SR and +.
6. Remove 1.2 kilo-ohm checkout resistor from terminals SO and +. If used, reconnect sensor from terminals SO and +.
7. Remove jumper from TR to N.
8. Remove jumper from TR to 1.
9. Remove 5.6 kilo-ohm resistor from T and T1. Reconnect wires at T and T1.
10. Remove jumper from P to P1. Reconnect device at P and P1.
11. Apply power (24 vac) to terminals TR and TR1.

EconoMiSer® X (Factory Option)

The EconoMiSer X system is an expandable economizer control system, which includes a W7220 economizer module (controller) with an LCD and keypad (see Fig. 61). The W7220 can be configured with optional sensors.



Fig. 61 — W7220 Economizer Module

The W7220 economizer module can be used as a stand-alone economizer module wired directly to a commercial set-back space thermostat and sensors to provide outside air dry-bulb economizer control.

The W7220 economizer module can be connected to optional sensors for single or differential enthalpy control. The W7220 economizer module provides power and communications for the sensors.

The W7220 economizer module automatically detects sensors by polling to determine which sensors are present. If a sensor loses communications after it has been detected, the W7220 economizer controller indicates a device fail error on its LCD.

SYSTEM COMPONENTS

The EconoMiSer X system includes an economizer module, 20k mixed air sensor, damper actuator, and either a 20k outdoor air temperature sensor or S-Bus enthalpy sensors.

Economizer Module

The module is the core of the EconoMiSer X system. The module is mounted in the unit's control box, and includes the user interface for the system. The W7220 economizer module provides the basic inputs and outputs to provide simple economizer control. When used with the optional sensors, the economizer module provides more advanced economizer functionality.

S-Bus Enthalpy Control Sensors

The sensor is a combination temperature and humidity sensor which is powered by and communicates on the S-Bus. Up to three sensors may be configured with the W7220 economizer module.

CO₂ Sensor (optional)

The CO₂ sensor can be added for Demand Controlled Ventilation (DCV).

SPECIFICATIONS

W7220 Economizer Module

The module is designed for use with 2 to 10 vdc or bus communicating actuator. The module includes terminals for CO₂ sensor, Mixed Air sensor, and an Outdoor Dry Bulb sensor. Enthalpy and other options are available with bus sensors.

User Interface

Provides status for normal operation, setup parameters, checkout tests, and alarm and error conditions with a 2-line 16 character LCD display and four button keypad.

Electrical

- Rated Voltage — 20 to 30 vac RMS, 50/60 Hz
- Transformer — 100 va maximum system input
- Nominal Power Consumption (at 24 vac, 60 Hz) — 11.5 VA without sensors or actuators

- Relay Digital Output Rating at 30 vac (maximum power from Class 2 input only) — 1.5A run; 3.5A inrush at 0.45PF (200,000 cycles) or 7.5A inrush at 0.45PF (100,000 cycles)
- External Sensors Power Output — 21 vdc ± 5% at 48mA

IMPORTANT: All inputs and outputs must be Class 2 wiring.

INPUTS

Sensors

NOTE: A Mixed Air (MA) analog sensor is required on all W7220 units; either an Outdoor Air (OA) sensor for dry bulb change over or an OA bus sensor for outdoor enthalpy change over is required in addition to the MA sensor. An additional Return Air (RA) bus sensor can be added to the system for differential enthalpy or dry bulb changeover. For differential dry bulb changeover, a 20k ohm sensor is required in the OA and a bus sensor in the RA. DIP switch on RA bus sensor must be set in the RA position.

Dry Bulb Temperature (optional) and Mixed Air (required), 20k NTC

2-wire (18 to 22 AWG);
 Temperature range -40°F to 150°F (-40°C to 66°C)
 Temperature accuracy: 0°F/+2°F

Temperature and Humidity, C7400S1000 (optional)

S-Bus; 2-wire (18 to 22 AWG)
 Temperature: range -40°F to 150°F (-40°C to 65°C)
 Temperature accuracy: 0°F/+2°F
 Humidity: range 0 to 100% RH with 5% accuracy.

NOTE: Up to three (3) S-Bus sensors may be connected to the W7220 economizer module for outdoor air (OA), return air (RA) and discharge (supply) air (DA).

4 Binary Inputs

1-wire 24 vac + common GND (see page 44 for wiring details).

24 vac power supply

20 to 30 vac 50/60Hz; 100 VA Class 2 transformer.

OUTPUTS

Actuator Signal

2 to 10 vdc; minimum actuator impedance is 2k ohm; bus two-wire output for bus communicating actuators.

Exhaust fan, Y1, Y2 and AUX1 O

All Relay Outputs (at 30 vac):

Running: 1.5A maximum

Inrush: 7.5A maximum

ENVIRONMENTAL

Operating Temperature

-40°F to 150°F (-40°C to 65°C).

Exception of display operation down to -4°F (-20°C) with full recovery at -4°F (-20°C) from exposure to -40°F (-40°C)

Storage Temperature

-40°F to 150°F (-40°C to 65°C)

Shipping Temperature

-40°F to 150°F (-40°C to 65°C)

Relative Humidity

5% to 95% RH non-condensing

ECONOMIZER MODULE WIRING DETAILS

Use Fig. 62 and Tables 11 and 12 to locate the wiring terminals for the Economizer module.

NOTE: The four terminal blocks are removable. Slide out each terminal block, wire it, and then slide it back into place.

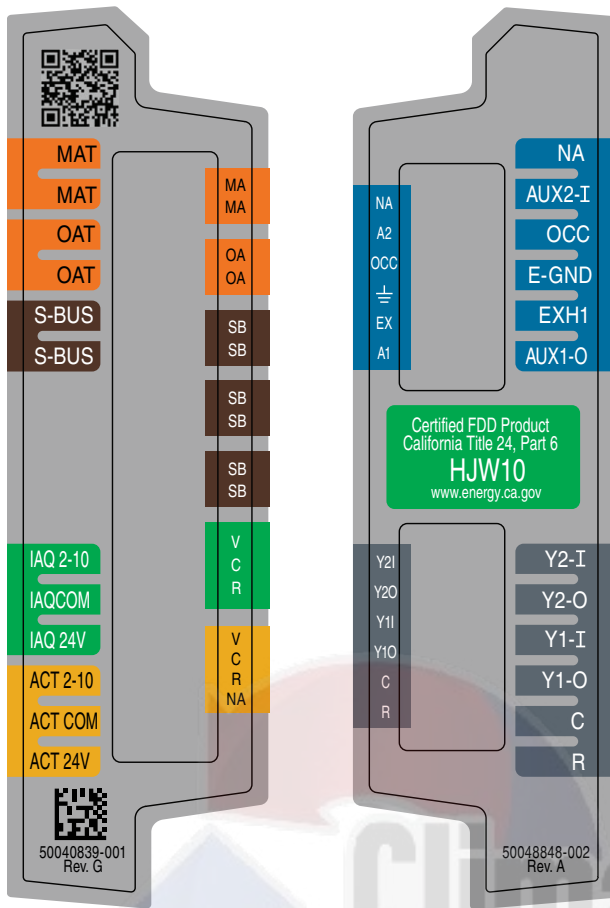

Fig. 62 — W7220 Wiring Terminals

Table 11 — Economizer Module (Left Hand Terminal Blocks)

LABEL	TYPE	DESCRIPTION
Top Left Terminal Block		
MAT	20k NTC	Mixed Air Temperature Sensor (Polarity Insensitive Connection)
MAT	and COM	
OAT	20k NTC	Outdoor Air Temperature Sensor (Polarity Insensitive Connection)
OAT	and COM	
S-BUS	S-BUS	Enthalpy Control Sensor (Polarity Insensitive Connection)
S-BUS	(Sylk* Bus)	
Bottom Left Terminal Block		
IAQ 2-10	2-10 vdc	Air Quality Sensor Input (e.g. CO ₂ sensor)
IAQ COM	COM	Air Quality Sensor Common
IAQ 24V	24 vac	Air Quality Sensor 24 vac Source
ACT 2-10	2-10 vdc	Damper Actuator Output (2-10 vdc)
ACT COM	COM	Damper Actuator Output Common
ACT 24v	24 vac	Damper Actuator 24 vac Source

*Sylk is a trademark of Honeywell International Inc.

Table 12 — Economizer Module (Right Hand Terminal Blocks)

LABEL	TYPE	DESCRIPTION
Top Right Terminal Blocks		
AUX2 I	24 vac IN	The first terminal is not used.
OCC	24 vac IN	Shut Down (SD) or HEAT (W) Conventional only and Heat Pump Changeover (O-B) in Heat Pump mode.
E-GND	E-GND	Occupied/Unoccupied Input
EXH1	24 vac OUT	Exhaust Fan 1 Output
AUX1 O	24 vac OUT	Programmable: Exhaust fan 2 output or ERV or System alarm output
Bottom Right Terminal Blocks		
Y2-I	24 vac IN	Y2 in - Cooling Stage 2 Input from space thermostat
Y2-O	24 vac OUT	Y2 out - Cooling Stage 2 Output to stage 2 mechanical cooling
Y1-I	24 vac IN	Y1 in - Cooling Stage 2 Input from space thermostat
Y1-O	24 vac OUT	Y1 out - Cooling Stage 2 Output to stage 2 mechanical cooling
C	COM	24 vac Common
R	24 vac	24 vac Power (hot)

S-Bus Sensor Wiring

The labels on the sensors and controller are color coded for ease of installation. Orange labeled sensors can only be wired to orange terminals on the controller. Brown labeled sensors can only be wired to S-bus (brown) terminals. Use Fig. 63 and Table 13 to locate the wiring terminals for each S-Bus and enthalpy control sensor.

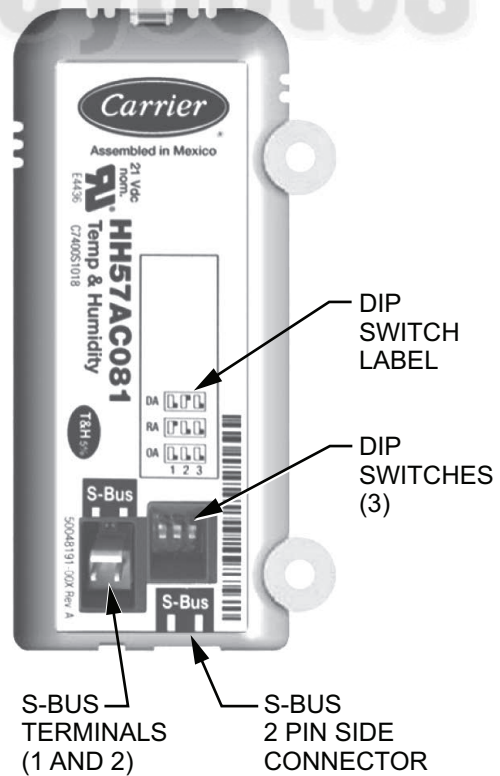

Fig. 63 — S-Bus Sensor DIP Switches

Table 13 — HH57AC081 Sensor Wiring Terminations

TERMINAL		TYPE	DESCRIPTION
NUMBER	LABEL		
1	S-BUS	S-BUS	S-BUS Communications (Enthalpy Control Sensor Bus)
2	S-BUS	S-BUS	S-BUS Communications (Enthalpy Control Sensor Bus)

Use Fig. 63 and Table 14 to set the DIP switches for the desired use of the sensor.

Table 14 — HH57AC081 Sensor DIP Switch

USE	DIP SWITCH POSITIONS FOR SWITCHES 1, 2, AND 3		
	1	2	3
DA	OFF	ON	OFF
RA	ON	OFF	OFF
OA	OFF	OFF	OFF

NOTE: When an S-Bus sensor is connected to an existing network, it will take 60 minutes for the network to recognize and auto-configure itself to use the new sensor.

During the 60 minute setup period, no alarms for sensor failures (except SAT) will be issued and no economizing function will be available.

CO₂ Sensor Wiring

When using a CO₂ sensor, the black and brown common wires are internally connected and only one is connected to “IAQ COM” on the W7220. Use the power from the W7220 to power the CO₂ sensor OR make sure the ground for the power supplies are common. See Fig. 64 for CO₂ sensor wiring.

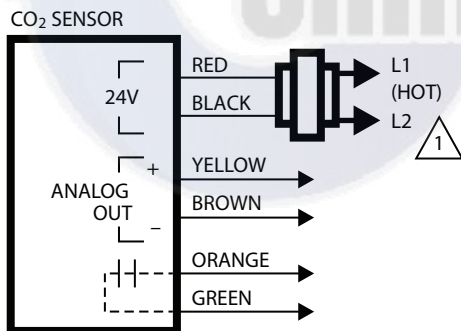

1 POWER SUPPLY. PROVIDE DISCONNECT MEANS AND OVERLOAD PROTECTION AS REQUIRED.

Fig. 64 — CO₂ Sensor Wiring

INTERFACE OVERVIEW

This section describes how to use the EconoMiSer[®] user interface for:

- Keypad and menu navigation
- Settings and parameter changes
- Menu structure and selection

User Interface

The user interface consists of a 2-line LCD display and a 4-button keypad on the front of the economizer controller.

Keypad

Use the four navigation buttons (see Fig. 65) to scroll through the menus and menu items, select menu items, and to change parameter and configuration settings.

To use the keypad when working with menus:

- Press the ▲ (Up arrow) button to move to the previous menu.
- Press the ▼ (Down arrow) button to move to the next menu.
- Press the ↵ (Enter) button to display the first item in the currently displayed menu.
- Press the ⏪ (Menu Up/Exit) button to exit a menu’s item and return to the list of menus.

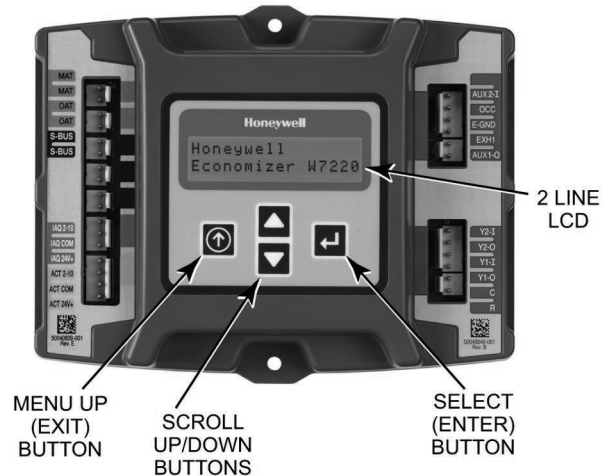

Fig. 65 — W7220 Controller Navigation Buttons

To use the keypad when working with Setpoints, System and Advanced Settings, Checkout tests and Alarms:

1. Navigate to the desired menu.
2. Press the ↵ (Enter) button to display the first item in the currently displayed menu.
3. Use the ▲ and ▼ buttons to scroll to the desired parameter.
4. Press the ↵ (Enter) button to display the value of the currently displayed item.
5. Press the ▲ button to increase (change) the displayed parameter value.
6. Press the ▼ button to decrease (change) the displayed parameter value.

NOTE: When values are displayed, pressing and holding the ▲ or ▼ button causes the display to automatically increment or decrement.

1. Press the ↵ (Enter) button to accept the displayed value and store it in nonvolatile RAM. “CHANGE STORED” displays.
2. Press the ↵ (Enter) button to return to the current menu parameter.
3. Press the ⏪ (Menu Up/Exit) button to return to the previous menu.

Menu Structure

Table 15 illustrates the complete hierarchy of menus and parameters for the EconoMiSer[®] X system.

The Menus in display order are:

- STATUS
- SETPOINTS
- SYSTEM SETUP
- ADVANCED SETUP
- CHECKOUT
- ALARMS

NOTE: Some parameters in the menus use the letters MA or MAT, indicating a mixed air temperature sensor location before the cooling coil. This unit application has the control sensor located after the cooling coil, in the fan section, where it is designated as (Cooling) Supply Air Temperature or SAT sensor.

SETUP AND CONFIGURATION

Before being placed into service, the W7220 Economizer module must be set up and configured for the installed system.

IMPORTANT: During setup, the economizer module is live at all times.

The setup process uses a hierarchical menu structure that is easy to use. Press the ▲ and ▼ arrow buttons to move forward and backward through the menus and press the button to select and confirm setup item changes.

Time-Out and Screensaver

When no buttons have been pressed for 10 minutes, the LCD displays a screen saver, which cycles through the Status items. Each Status item displays in turn and cycles to the next item after 5 seconds.

Table 15 — W7220 Menu Structure*

MENU	PARAMETER	PARAMETER DEFAULT VALUE	PARAMETER RANGE AND INCREMENT†	EXPANDED PARAMETER NAME Notes
STATUS	ECON AVAIL	NO	YES/NO	FIRST STAGE COOLING DEMAND (Y1-IN) YES = economizing available; the system can use outside air for free cooling when required
	ECONOMIZING	NO	YES/NO	FIRST STAGE COOLING RELAY OUTPUT YES = outside air being used for first stage cooling
	OCCUPIED	NO	YES/NO	OCCUPIED YES = OCC signal received from space thermostat or unitary controller YES = 24 vac on terminal OCC NO = 0 vac on terminal OCC
	HEAT PUMP	—**	COOL HEAT	HEAT PUMP MODE Displays COOL or HEAT when system is set to heat pump (Non-conventional)
	COOL Y1—IN	OFF	ON/OFF	FIRST STAGE COOLING DEMAND (Y1-IN) Y1-I signal from space thermostat or unitary controller for cooling stage 1. ON = 24 vac on terminal Y1-I OFF = 0 vac on terminal Y1-I
	COOL Y1—OUT	OFF	ON/OFF	FIRST STAGE COOLING RELAY OUTPUT Cool stage 1 Relay Output to stage 1 mechanical cooling (Y1—OUT terminal)
	COOL Y2—IN	OFF	ON/OFF	SECOND STAGE COOLING DEMAND (Y2-IN) Y2-I signal from space thermostat or unitary controller for second stage cooling. ON = 24 vac on terminal Y2-I OFF = 0 vac on terminal Y2-I
	COOL Y2—OUT	OFF	ON/OFF	SECOND STAGE COOLING RELAY OUTPUT Cool Stage 2 Relay Output to mechanical cooling (Y2—OUT terminal)
	MA TEMP	____ °F (or ____ °C)	–40°F to 150°F (–40°C to 66°C)	SUPPLY AIR TEMPERATURE, Cooling Mode Displays value of measured mixed air from MAT sensor. Displays ____ °F if not connected, short or out of range.
	DA TEMP	____ °F (or ____ °C)	–40°F to 150°F (–40°C to 66°C)	DISCHARGE AIR TEMPERATURE, after Heating section Displays when Discharge Air Syk Bus sensor is connected and displays measured discharge temperature. Displays ____ °F if sensor sends invalid value, if not connected, short or out of range.
	OA TEMP	____ °F (or ____ °C)	–40°F to 140°F (–40°C to 60°C)	OUTSIDE AIR TEMP Displays measured value of outdoor air temperature. Displays ____ °F if sensor sends invalid value, short or out of range.
	OA HUM	__ %	0 to 100%	OUTSIDE AIR RELATIVE HUMIDITY Displays measured value of outdoor humidity from OA Syk Bus sensor. Displays __ % if not connected short, or out of range.
	RA TEMP	____ °F (or ____ °C)	0°F to 140°F (–18°C to 60°C)	RETURN AIR TEMPERATURE Displays measured value of return air temperature from RAT Syk Bus sensor. Displays ____ °F if sensor sends invalid value, if not connected, short or out of range
	RA HUM	__ %	0 to 100%	RETURN AIR RELATIVE HUMIDITY Displays measured value of return air humidity from RA Syk Bus sensor. Displays __ % if sensor sends invalid value, if not connected, short or out of range
IN CO2	____ ppm	0 to 2000 ppm	SPACE/RETURN AIR CO ₂ Displays value of measured CO ₂ from CO ₂ sensor. Invalid if not connected, short or out of range. May be adjusted in Advanced menu by Zero offset and Span.	

Table 15 — W7220 Menu Structure* (cont)

MENU	PARAMETER	PARAMETER DEFAULT VALUE	PARAMETER RANGE AND INCREMENT†	EXPANDED PARAMETER NAME Notes
STATUS (cont)	DCV STATUS	—	ON/OFF	DEMAND CONTROLLED VENTILATION STATUS Displays ON if above set point and OFF if below set point, and ONLY if a CO ₂ sensor is connected.
	DAMPER OUT	2.0v	2.0 to 10.0v	Displays voltage output to the damper actuator.***
	ACT POS	—	0 to 100%	Displays actual position of actuator
	ACT COUNT	—	1 to 65,535	Displays number of times actuator has cycled. 1 cycle equals 180 degrees of actuator movement in any direction.
	ACTUATOR	—	OK/Alarm (on Alarm menu)	Displays ERROR if voltage or torque is below actuator range.
	EXH1 OUT	OFF	ON/OFF	EXHAUST STAGE 1 RELAY OUTPUT Displays ON when damper position reaches programmed percentage set point. Output of EXH1 terminal: ON = relay closed OFF = relay open
	EXH2 OUT	OFF	ON/OFF	EXHAUST STAGE 2 RELAY OUTPUT Output of AUX1 O terminal Displays ON when damper position reaches programmed percentage set point. ON = 24 vac output OFF = No output Displays only if AUX1 O = EXH2
	ERV	OFF	ON/OFF	ENERGY RECOVERY VENTILATOR Output of AUX1 O terminal; displays only if AUX1 O = ERV ON = 24 vac output OFF = No Output
	MECH COOL ON or HEAT STAGES ON	0	0, 1, or 2	Displays stage of mechanical cooling that is active. Displays the stage of heat pump heating that is active.
	FAN SPEED	—	LOW or HIGH	SUPPLY FAN SPEED Displays speed setting of fan on a 2-speed fan unit.
W (HEAT IN)	—	ON/OFF	HEAT DEMAND STATUS Displays status of heat demand on a 2-speed fan unit.	
SETPOINTS	MAT SET	53°F (12°C)	38°F to 70°F (3°C to 21°C); increment by 1°F	SUPPLY AIR SETPOINT The economizer will modulate the OA damper to maintain the mixed air temperature at the set point
	LOW T LOCK	32°F (0°C)	-45°F to 80°F (-43°C to 27°C); increment by 1°F	COMPRESSOR LOW TEMPERATURE LOCKOUT Set point determines outdoor temperature when the mechanical cooling cannot be turned on. Commonly referred to as the Compressor lockout. At or below the set point, the Y1-O and Y2-O will not be energized on the controller.
	DRYBLB SET	63°F (17°C)	48°F to 80°F (9°C to 27°C); increment by 1°F	OA DRY BULB TEMPERATURE CHANGEOVER SETPOINT Dry bulb set point will only appear if using dry bulb changeover. Set point determines where the economizer will assume outdoor air temperature is good for free cooling; e.g.; at 63°F unit will economize at 62°F and below and not economize at 64°F and above. There is a 2°F deadband.
	ENTH CURVE	ES3	ES1, ES2, ES3, ES4, or ES5	ENTHALPY CHANGEOVER CURVE ES curve will only appear if using enthalpy changeover. Enthalpy boundary "curves" for economizing using single enthalpy. See page 54 for description of enthalpy curves.
	DCV SET	1100ppm	500 to 2000 ppm; increment by 100	DEMAND CONTROLLED VENTILATION Displays only if CO ₂ sensor is connected. Set point for Demand Controlled Ventilation of space. Above the set point, the OA dampers will modulate open to bring in additional OA to maintain a space ppm level below the set point.
	MIN POS	2.8 V	2 to 10 vdc	VENTILATION MINIMUM POSITION Displays ONLY if a CO ₂ sensor is NOT connected. With 2-speed fan units, MIN POS L (low speed fan) and MIN POS H (high speed fan) settings are required. Default for MIN POS L is 3.2V and MIN POS H is 2.8V.
	VENTMAX	2.8 V	2 to 10 vdc 100 to 9990 cfm; increment by 10 2 to 10 vdc	DCV MAXIMUM DAMPER POSITION Displays only if a CO ₂ sensor is connected. Used for Vbz (ventilation max cfm) set point. VENTMAX is the same setting as MIN POS would be if unit did not have CO ₂ sensor. If OA, MA, RA, and CO ₂ sensors are connected and DCV CAL ENABLE is set to AUTO mode, the OA dampers are controlled by CFM and displays from 100 to 9990 CFM. With 2-speed fan units, VENTMAX L (low speed fan) and VENTMAX H (high speed fan) settings are required. Default for VENTMAX L is 3.2V and VENTMAX H is 2.8V

Table 15 — W7220 Menu Structure* (cont)

MENU	PARAMETER	PARAMETER DEFAULT VALUE	PARAMETER RANGE AND INCREMENT†	EXPANDED PARAMETER NAME Notes
SETPOINTS (cont)	VENTMIN	2.25 V	2 to 10 vdc or 100 to 9990 cfm increment by 10	DCV MINIMUM DAMPER POSITION Displays only if a CO ₂ sensor is connected. Used for Va (ventilation min cfm) set point. This is the ventilation for less than maximum occupancy of the space.
			100 to 9990 cfm; increment by 10	If OA, MA, RA, and CO ₂ sensors are connected and DCV CAL ENABLE is set to AUTO mode, the OA dampers are controlled by CFM and displays from 100 to 9990 CFM.
			2 to 10 vdc	With 2-speed fan units VENTMIN L (low speed fan) and VENTMIN H (high speed fan) settings are required. Default for VENTMIN L is 2.5V and VENTMIN H is 2.25V
	ERV OAT SP††	32°F (0°C)	0°F to 50°F (-18°C to 10°C); increment by 1 degree	ENERGY RECOVERY VENTILATOR UNIT OUTDOOR AIR TEMPERATURE SETPOINT Only when AUX1 O = ERV
	EXH1 SET	50%	0 to 100%; increment by 1	EXHAUST FAN STAGE 1 SETPOINT Set point for OA damper position when exhaust fan 1 is powered by the economizer. With 2-speed fan units, Exh1 L (low speed fan) and Exh1 H (high speed fan) settings are required. Default for Exh1 L is 65% and Exh1 H is 50%
EXH2 SET	75%	0 to 100%; increment by 1	EXHAUST FAN STAGE 2 SETPOINT Set point for OA damper position when exhaust fan 2 is powered by the economizer. Only used when AUX1 O is set to EXH2. With 2-speed fan units, Exh2 L (low speed fan) and Exh2 H (high speed fan) settings are required. Default for Exh2 L is 80% and Exh2 H is 75%	
SYSTEM SETUP	INSTALL	01/01/10	—	Display order = MM/DD/YY Setting order = DD, MM, then YY.
	UNITS DEG	°F	°F or °C	Sets economizer controller in degrees Fahrenheit or Celsius
	EQUIPMENT	CONV	CONV or HP	CONV = conventional; HP O/B = Enable Heat Pump mode. Use AUX2 I for Heat Pump input from thermostat or controller.
	AUX2 IN	W	Shutdown (SD) Heat (W1) HP(O) HP(B)	In CONV mode: SD = Enables configuration of shutdown (default); W = Informs controller that system is in heating mode. NOTE: If using 2-speed fan mode, you must program CONV mode for W. Shutdown is not available in 2-speed fan mode. In HP O/B mode: HP(O) = energize heat pump on Cool (default); HP(B) = energize heat pump on heat.
	FAN SPEED	2 speed	1 speed/2 speed	Sets the economizer controller for operation of 1 speed or 2 speed supply fan. The controller does not control the fan, but positions the OA and RA dampers to heating or cooling mode. NOTE: 2-speed fan option also needs Heat (W1) programmed in AUX 2 In.
	FAN CFM	5000 cfm	100 to 15000 cfm; increment by 100	UNIT DESIGN AIRFLOW (CFM) Enter only if using DCVCAL ENA = AUTO This is the capacity of the RTU. The value is found on the nameplate label for the specific unit.
	AUX1 OUT	NONE	NONE ERV EXH2 SYS	Select OUTPUT for AUX1 O relay • NONE = not configured (output is not used) • ERV = Energy Recovery Ventilator†† • EXH2 = second damper position 24 vac out for second exhaust fan • SYS = use output as an alarm signal
	OCC	INPUT	INPUT or ALWAYS	OCCUPIED MODE BY EXTERNAL SIGNAL When using a setback thermostat with occupancy out (24 vac), the 24 vac is input "INPUT" to the OCC terminal. If no occupancy output from the thermostat, then change program to "ALWAYS" OR add a jumper from terminal R to OCC terminal.
	FACTORY DEFAULT	NO	NO or YES	Resets all set points to factory defaults when set to YES. LCD will briefly flash YES and change to NO but all parameters will change to the factory default values.
ADVANCED SETUP	MA LO SET	45°F (7°C)	35°F to 65°F (2°C to 18°C); Increment by 1°F	SUPPLY AIR TEMPERATURE LOW LIMIT Temperature to activate Freeze Protection (close damper or modulate to MIN POS if temp falls below set value).
	FREEZE POS	CLO	CLO or MIN	FREEZE PROTECTION DAMPER POSITION Damper position when freeze protection is active (closed or MIN POS).
	CO2 ZERO	0ppm	0 to 500 ppm; Increment by 10	CO ₂ ppm level to match CO ₂ sensor start level.
	CO2 SPAN	2000ppm	1000 to 3000 ppm; Increment by 50	CO ₂ ppm span to match CO ₂ sensor; e.g.: 500-1500 sensor output would be 500 CO ₂ zero and 1000 CO ₂ span.

Table 15 — W7220 Menu Structure* (cont)

MENU	PARAMETER	PARAMETER DEFAULT VALUE	PARAMETER RANGE AND INCREMENT†	EXPANDED PARAMETER NAME Notes
ADVANCED SETUP (cont)	STG3 DLY	2.0h	0 min, 5 min, 15 min, then 15 min intervals. Up to 4 hrs or OFF	COOLING STAGE 3 DELAY Delay after stage 2 cool has been active. Turns on second stage of cooling when economizer is first stage call and mechanical cooling is second stage call. Allows three stages of cooling, 1 economizer and 2 mechanical. OFF = no Stage 3 cooling
	SD DMPR POS	CLO	CLO or OPN	Indicates shutdown signal from space thermostat or unitary controller. When controller receives 24 vac input on the SD terminal in conventional mode, the OA damper will open if programmed for OPN and OA damper will close if programmed for CLO. All other controls, e.g., fans, etc. will shut off.
	DA LO ALM	45°F (7°C)	NONE 35°F to 65°F (2°C to 18°C); Increment by 5°F	Used for alarm for when the DA air temperature is too low. Set lower range of alarm, below this temperature the alarm will show on the display.
	DA HI ALM	80°F (27°C)	NONE 70°F to 180°F (21°C to 82°C); Increment by 5°F	Used for alarm for when the DA air temperature is too high. Sets upper range of alarm; above this temperature, the alarm will show on the display.
	DCVCAL ENA	MAN	MAN (manual) AUTO	Turns on the DCV automatic control of the dampers. Resets ventilation based on the RA, OA, and MA sensor conditions. Requires all (RA, OA, MA, CO ₂) sensors. This operation is not operable with a 2-speed fan unit.
	MAT T CAL	0.0°F	± 2.5°F	SUPPLY AIR TEMPERATURE CALIBRATION Allows for the operator to adjust for an out of calibration temperature sensor.
	OAS T CAL	0.0°F	± 2.5°F	OUTSIDE AIR TEMPERATURE CALIBRATION Allows for the operator to adjust for an out of calibration temperature sensor.
	OA H CAL	0% RH	±10% RH	OUTSIDE AIR HUMIDITY CALIBRATION Allows for operator to adjust for an out of calibration humidity sensor.
	RA T CAL	0.0°F	± 2.5°F	RETURN AIR TEMPERATURE CALIBRATION Allows for the operator to adjust for an out of calibration temperature sensor.
	RA H CAL	0% RH	±10% RH	RETURN AIR HUMIDITY CALIBRATION Allows for operator to adjust for an out of calibration humidity sensor.
	DA T CAL	0.0°F	± 2.5°F	DISCHARGE AIR TEMPERATURE CALIBRATION Allows for the operator to adjust for an out of calibration temperature sensor.
	2SP FAN DELAY	5 Minutes	0 to 20 minutes in 1 minute increments	TIME DELAY ON SECOND STAGE ECONOMIZING When in economizing mode, this is the delay for the high speed fan to try to satisfy the call for second stage cooling before the first stage mechanical cooling is enabled.
CHECKOUT***	DAMPER MINIMUM POSITION	—	—	The checkout for the damper minimum position is based on the system. See Table 16.
	DAMPER OPEN	—	—	Position damper to the full open position. Exhaust fan contacts enable during the DAMPER OPEN test. Make sure to pause in the mode to allow exhaust contacts to energize due to the delay in the system.
	DAMPER CLOSE	—	—	Positions damper to the fully closed position
	CONNECT Y1-O	—	—	Closes the Y1-O relay (Y1-O)
	CONNECT Y2-O	—	—	Closes the Y2-O relay (Y2-O)
	CONNECT AUX1-O	—	—	Energizes the AUX output. If Aux setting is: • NONE — no action taken • ERV — 24 vac out. Turns on or signals an ERV that the conditions are not good for economizing but are for ERV operation.†† • SYS — 24 vac out. Issues a system alarm
CONNECT EXH1	—	—	Closes the power exhaust fan 1 relay (EXH1)	
ALARMS	Alarms display only when they are active. The menu title "ALARMS(#)" includes the number of active alarms in parenthesis (). When using SYLK bus sensors, "SYLK" will appear on the screen, and when using 20k OA temperature sensors, "SENS T" will appear on the screen			
	MA T SENS ERR	—	—	SUPPLY AIR TEMPERATURE SENSOR ERROR Mixed air sensor has failed or become disconnected - check wiring, then replace sensor if the alarm continues.
	CO2 SENS ERR	—	—	CO ₂ SENSOR ERROR CO ₂ sensor has failed, gone out of range or become disconnected - check wiring then replace sensor if the alarm continues.
	OA SYLK T ERR	—	—	OUTSIDE AIR S-BUS SENSOR ERROR
	OA SYLK H ERR	—	—	Outdoor air enthalpy sensor has failed or become disconnected - check wiring, then replace sensor if the alarm continues.

Table 15 — W7220 Menu Structure* (cont)

MENU	PARAMETER	PARAMETER DEFAULT VALUE	PARAMETER RANGE AND INCREMENT†	EXPANDED PARAMETER NAME Notes
ALARMS (cont)	RA SYLK T ERR	—	—	RETURN AIR S-BUS SENSOR ERROR Return air enthalpy sensor has failed or become disconnected - check wiring, then replace sensor if the alarm continues.
	RA SYLK H ERR	—	—	DISCHARGE AIR S-BUS SENSOR ERROR Discharge air sensor has failed or become disconnected - check wiring, then replace sensor if the alarm continues.
	DA SYLK T ERR	—	—	OUTSIDE AIR TEMPERATURE SENSOR ERROR Outdoor air temperature sensor has failed or become disconnected - check wiring, then replace if the alarm continues.
	OA SENS T ERR	—	—	ACTUATOR ERROR Actuator has failed or become disconnected - check for stall, over voltage, under voltage and actuator count. Replace actuator if damper is movable and supply voltage is between 21.6 V and 26.4 V. Check actuator count on STATUS menu.
	ACT ERROR	—	—	Check if outdoor temperature is below the LOW Temp Lockout on set point menu. Check if Mixed air temperature on STATUS menu is below the Lo Set point on Advanced menu. When conditions are back in normal range, the alarm will go away.
	FREEZE ALARM	—	—	AUX2 IN is programmed for SHUTDOWN and 24 V has been applied to AUX2 IN terminal.
	SHUTDOWN ACTIVE	—	—	DAMPER CALIBRATION ROUTINE RUNNING If DCV Auto enable has been programmed, this alarm will display when the W7220 is completing a calibration on the dampers. Wait until the calibration is completed and the alarm will go away. Must have OA, MA and RA sensors for DCV calibration; set up is in the Advanced setup menu.
	DMP CAL RUNNING	—	—	DISCHARGE AIR TEMPERATURE SENSOR ALARM Discharge air temperature is out of the range set in the ADVANCED SETUP Menu. Check the temperature of the discharge air.
	DA SENS ALM	—	—	When AUX1-O is set to SYS and there is any alarm (e.g., failed sensors, etc.), the AUX1-O terminal has 24 vac out.
	SYS ALARM	—	—	ACTUATOR VOLTAGE LOW Voltage received by actuator is above expected range.
	ACT UNDER V	—	—	ACTUATOR VOLTAGE HIGH Voltage received by actuator is below expected range.
	ACT OVER V	—	—	ACTUATOR STALLED Actuator stopped before achieving commanded position.
	ACT STALLED	—	—	

LEGEND

- CLO** — Compressor Lockout
- ERV** — Energy Recovery Ventilator
- LCD** — Liquid Crystal Display
- MA** — Mixed Air
- MAT** — Mixed Air Temperature
- — Not Applicable
- OA** — Outdoor Air
- OAT** — Outdoor Air Temperature
- OCC** — Occupied
- RA** — Return Air
- RAT** — Return Air Temperature
- RTU** — Rooftop Unit
- SYS** — System

* Table 15 illustrates the complete hierarchy. Your menu parameters may be different depending on your configuration. For example, if you do not have a DCV (CO₂) sensor, then none of the DCV parameters appear.

† When values are displayed, pressing and holding the ▲ or ▼ button causes the display to automatically increment.

** — = Not Applicable.

†† ERV Operation: When in cooling mode AND the conditions are NOT OK for economizing - the ERV terminal will be energized. In the Heating mode, the ERV terminal will be energized when the OA is below the ERV OAT set point in the set point menu.

*** After 10 minutes without a command or mode change, the controller will change to normal operation.

NOTES:

1. STATUS → OCCUPIED — The factory-standard Occupancy signal originates with a thermostat or other controller call for indoor fan operation at CTB terminal G. This signal passes through the Central Terminal Board's OCCUPANCY jumper to the ECONO connector and to the W7220's OCC input terminal. An external timeclock or relay is required to implement an Occupancy schedule on the economizer damper position.
2. STATUS → MA TEMP, SETPOINTS → MAT SET — The W7220 menu parameters and labels include designations MA, MAT and Mixed Air for the economizer cooling control sensor. On these rooftop units, the economizer control sensor is located downstream of the evaporator/indoor coil in the supply fan section where this sensor is designated as Supply Air Temperature (SAT) sensor.
3. SETPOINTS → DRYBLB SET — This point is not displayed if a Return Air (differential) temperature sensor or an Outdoor Air enthalpy sensor is connected.
4. SYSTEM SETUP parameters must be configured as noted for 2-Speed unit operation:
EQUIPMENT = CONV
AUX2 I = W
FAN SPEED = 2SPEED

For damper minimum position settings and checkout menu readings, see Table 16. For dry bulb operation with a 1-speed fan, with or without DCV, see Tables 17 and 18. For enthalpy operation with a 1-speed fan, with or without DCV, see Tables 19 and 20. For dry bulb operation with a 2-speed indoor fan, with or without DCV, see Tables 21 and 22. For enthalpy operation with a 2-speed indoor fan, with or without DCV, see Tables 23 and 24.

Table 16 — Damper Minimum Position Settings and Readings on Checkout Menu

DEMAND CONTROLLED VENTILATION (CO ₂ SENSOR)	FAN SPEED	SETPOINTS	CHECKOUT
NO	1	MIN POS	VMAX-HS
		—	—
	2	MIN POS H MIN POS L	VMAX-HS VMAX-LS
YES	1	VENT MIN	VMAX-HS
		VENT MAX	VMAX-HS
	2	VENT MIN H	VMAX-HS
		VENT MAX H	VMAX-LS
		VENT MIN L	—
		VENT MAX L	—

Table 17 — Dry Bulb Operation without DCV (CO₂ Sensor) — 1 Speed Fan

DEMAND CONTROLLED VENTILATION (DCV)	OUTSIDE AIR GOOD TO ECONOMIZE	Y1-I	Y2-I	FAN SPEED	Y1-O	Y2-O	OCCUPIED	UNOCCUPIED
NONE	No	Off	Off	High	0-v/Off	0-v/Off	MIN POS	Closed
		On	Off	High	24-v/On	0-v/Off	MIN POS	Closed
		On	On	High	24-v/On	24-v/On	MIN POS	Closed
	Yes	Off	Off	High	0-v/Off	0-v/Off	MIN POS	Closed
		On	Off	High	0-v/Off	0-v/Off	MIN POS to Full-Open	Closed to Full-Open
		On	On	High	24-v/On	0-v/Off*	MIN POS to Full-Open	Closed to Full-Open

*With stage 3 delay (STG3 DLY) in Advanced setup menu can turn on second stage of mechanical cooling Y2-O after the delay if the call for Y-I and Y2-I have not been satisfied.

Table 18 — Dry Bulb Operation with DCV (CO₂ Sensor) — 1 Speed Fan

DEMAND CONTROLLED VENTILATION (DCV)	OUTSIDE AIR GOOD TO ECONOMIZE	Y1-I	Y2-I	FAN SPEED	Y1-O	Y2-O	OCCUPIED	UNOCCUPIED
Below CO ₂ set	No	Off	Off	High	0-v/Off	0-v/Off	VENTMIN	Closed
		On	Off	High	24-v/On	0-v/Off	VENTMIN	Closed
		On	On	High	24-v/On	24-v/On	VENTMIN	Closed
	Yes	Off	Off	High	0-v/Off	0-v/Off	VENTMIN	Closed
		On	Off	High	0-v/Off	0-v/Off	VENTMIN to Full-Open	Closed to Full-Open
		On	On	High	24-v/On	0-v/Off*	VENTMIN to Full-Open	Closed to Full-Open
Above CO ₂ set	No	Off	Off	High	0-v/Off	0-v/Off	VENTMIN to VENTMAX	Closed
		On	Off	High	24-v/On	0-v/Off	VENTMIN to VENTMAX	Closed
		On	On	High	24-v/On	24-v/On	VENTMIN to VENTMAX	Closed
	Yes	Off	Off	High	0-v/Off	0-v/Off	VENTMIN to VENTMAX	Closed
		On	Off	High	0-v/Off	0-v/Off	VENTMIN to Full-Open	Closed to Full-Open
		On	On	High	24-v/On	0-v/Off*	VENTMIN to Full-Open	Closed to Full-Open

*With stage 3 delay (STG3 DLY) in Advanced setup menu can turn on second stage of mechanical cooling Y2-O after the delay if the call for Y-I and Y2-I have not been satisfied.

Table 19 — Enthalpy Operation without DCV (CO₂ Sensor) — 1 Speed Fan

DEMAND CONTROLLED VENTILATION (DCV)	OUTSIDE AIR GOOD TO ECONOMIZE	Y1-I	Y2-I	FAN SPEED	Y1-O	Y2-O	OCCUPIED	UNOCCUPIED
NONE	No	Off	Off	High	0-v/Off	0-v/Off	MIN POS	Closed
		On	Off	High	24-v/On	0-v/Off	MIN POS	Closed
		On	On	High	24-v/On	24-v/On	MIN POS	Closed
	Yes	Off	Off	High	0-v/Off	0-v/Off	MIN POS	Closed
		On	Off	High	0-v/Off	0-v/Off	MIN POS to Full-Open	Closed to Full-Open
		On	On	High	24-v/On	0-v/Off*	MIN POS to Full-Open	Closed to Full-Open

*With stage 3 delay (STG3 DLY) in Advanced setup menu can turn on second stage of mechanical cooling Y2-O after the delay if the call for Y-I and Y2-I have not been satisfied.

Table 20 — Enthalpy Operation with DCV (CO₂ Sensor) — 1 Speed Fan

DEMAND CONTROLLED VENTILATION (DCV)	OUTSIDE AIR GOOD TO ECONOMIZE	Y1-I	Y2-I	FAN SPEED	Y1-O	Y2-O	OCCUPIED	UNOCCUPIED
Below CO ₂ set	No	Off	Off	High	0-v/Off	0-v/Off	VENTMIN	Closed
		On	Off	High	24-v/On	0-v/Off	VENTMIN	Closed
		On	On	High	24-v/On	24-v/On	VENTMIN	Closed
	Yes	Off	Off	High	0-v/Off	0-v/Off	VENTMIN	Closed
		On	Off	High	0-v/Off	0-v/Off	VENTMIN to Full-Open	Closed to Full-Open
		On	On	High	24-v/On	0-v/Off†	VENTMIN to Full-Open	Closed to Full-Open
Above CO ₂ set	No	Off	Off	High	0-v/Off	0-v/Off	VENTMIN to VENTMAX	Closed
		On	Off	High	24-v/On	0-v/Off	VENTMIN L to VENTMAX	Closed
		On	On	High	24-v/On	24-v/On	VENTMIN H to VENTMAX	Closed
	Yes	Off	Off	High	0-v/Off	0-v/Off	VENTMIN L to VENTMAX	Closed
		On	Off	High	0-v/Off	0-v/Off	VENTMIN to Full-Open	Closed to Full-Open
		On	On	High	DELAY* 24-v/On	0-v/Off†	VENTMIN to Full-Open	Closed to Full-Open

*With 2SP FAN DELAY (Advanced Setup Menu) when in the economizing mode there is a delay for the high speed fan to try to satisfy the call for second stage cooling by turning on the fan to high and opening the OA damper 100% before the first stage mechanical cooling is enabled.

†With stage 3 delay (STG3 DLY) in Advanced setup menu can turn on second stage of mechanical cooling Y2-O after the delay if the call for Y-I and Y2-I have not been satisfied.

Table 21 — Dry Bulb Operation without DCV (CO₂ Sensor) — 2 Speed Fan

DEMAND CONTROLLED VENTILATION (DCV)	OUTSIDE AIR GOOD TO ECONOMIZE	Y1-I	Y2-I	FAN SPEED	Y1-O	Y2-O	OCCUPIED	UNOCCUPIED
NONE	No	Off	Off	Low	0-v/Off	0-v/Off	MIN POS L	Closed
		On	Off	Low	24-v/On	0-v/Off	MIN POS L	Closed
		On	On	High	24-v/On	24-v/On	MIN POS H	Closed
NONE	Yes	Off	Off	Low	0-v/Off	0-v/Off	MIN POS L	Closed
		On	Off	Low	0-v/Off	0-v/Off	MIN POS L to Full-Open	Closed to Full-Open
		On	On	High	DELAY* 24-v/On	0-v/Off†	MIN POS H to Full-Open	Closed to Full-Open

*With 2SP FAN DELAY (Advanced Setup Menu) when in the economizing mode there is a delay for the high speed fan to try to satisfy the call for second stage cooling by turning on the fan to high and opening the OA damper 100% before the first stage mechanical cooling is enabled.

†With stage 3 delay (STG3 DLY) in Advanced setup menu can turn on second stage of mechanical cooling Y2-O after the delay if the call for Y-I and Y2-I have not been satisfied.

Table 22 — Dry Bulb Operation with DCV (CO₂ Sensor) — 2 Speed Fan

DEMAND CONTROLLED VENTILATION (DCV)	OUTSIDE AIR GOOD TO ECONOMIZE	Y1-I	Y2-I	FAN SPEED	Y1-O	Y2-O	OCCUPIED	UNOCCUPIED
Below CO ₂ Set	No	OFF	OFF	LOW	0v/Off	0v/Off	VENTMIN	Closed
		ON	OFF	LOW	24v/On	0v/Off	VENTMIN	Closed
		ON	ON	HIGH	24v/On	24v/On	VENTMIN	Closed
	Yes	OFF	OFF	LOW	0v/Off	0v/Off	VENTMIN	Closed
		ON	OFF	LOW	0v/Off	0v/Off	VENTMIN to Full-Open	Closed to Full-Open
		ON	ON	HIGH	24v/On	0v/Off	VENTMIN to Full-Open	Closed to Full-Open
Above CO ₂ Set	No	OFF	OFF	LOW	0v/Off	0v/Off	VENTMIN to VENTMAX	Closed
		ON	OFF	LOW	24v/On	0v/Off	VENTMIN to VENTMAX	Closed
		ON	ON	HIGH	24v/On	24v/On	VENTMIN to VENTMAX	Closed
	Yes	OFF	OFF	LOW	0v/Off	0v/Off	VENTMIN to VENTMAX	Closed
		ON	OFF	LOW	0v/Off	0v/Off	VENTMIN to Full-Open	Closed to Full-Open
		ON	ON	HIGH	DELAY* 24v/On	0v/Off†	VENTMIN to Full-Open	Closed to Full-Open

*With 2SP FAN DELAY (Advanced Setup Menu) when in the economizing mode there is a delay for the high speed fan to try to satisfy the call for second stage cooling by turning on the fan to high and opening the OA damper 100% before the first stage mechanical cooling is enabled.

†With stage 3 delay (STG3 DLY) in Advanced setup menu can turn on second stage of mechanical cooling Y2-O after the delay if the call for Y1-I and Y2-I have not been satisfied.

Table 23 — Enthalpy Operation without DCV (CO₂ Sensor) — 2 Speed Fan

DEMAND CONTROLLED VENTILATION (DCV)	OUTSIDE AIR GOOD TO ECONOMIZE	Y1-I	Y2-I	FAN SPEED	Y1-O	Y2-O	OCCUPIED	UNOCCUPIED
NO CO ₂ SENSOR	NO	OFF	OFF	LOW	0v/Off	0v/Off	MIN POS	Closed
		ON	OFF	LOW	24v/On	0v/Off	MIN POS	Closed
		ON	ON	HIGH	24v/On	24v/On	MIN POS	Closed
	YES	OFF	OFF	LOW	0v/Off	0v/Off	MIN POS	Closed
		ON	OFF	LOW	0v/Off	0v/Off	MIN POS to Full Open	Closed to Full-Open
		ON	ON	HIGH	DELAY* 24v/On	0v/Off†	MIN POS to Full Open	Closed to Full-Open

*With 2SP FAN DELAY (Advanced Setup Menu) when in the economizing mode there is a delay for the high speed fan to try to satisfy the call for second stage cooling by turning on the fan to high and opening the OA damper 100% before the first stage mechanical cooling is enabled.

†With stage 3 delay (STG3 DLY) in Advanced setup menu can turn on second stage of mechanical cooling Y2-O after the delay if the call for Y1-I and Y2-I have not been satisfied.

Table 24 — Enthalpy Operation with DCV (CO₂ Sensor) — 2 Speed Fan

DEMAND CONTROLLED VENTILATION (DCV)	OUTSIDE AIR GOOD TO ECONOMIZE	Y1-I	Y2-I	FAN SPEED	Y1-O	Y2-O	OCCUPIED	UNOCCUPIED
Below CO ₂ Set	No	OFF	OFF	LOW	0v/Off	0v/Off	VENTMIN	Closed
		ON	OFF	LOW	24v/On	0v/Off	VENTMIN	Closed
		ON	ON	HIGH	24v/On	24v/On	VENTMIN	Closed
	Yes	OFF	OFF	LOW	0v/Off	0v/Off	VENTMIN	Closed
		ON	OFF	LOW	0v/Off	0v/Off	VENTMIN to Full-Open	Closed to Full-Open
		ON	ON	HIGH	24v/On	0v/Off	VENTMIN to Full-Open	Closed to Full-Open
Above CO ₂ Set	No	OFF	OFF	LOW	0v/Off	0v/Off	VENTMIN to VENTMAX	Closed
		ON	OFF	LOW	24v/On	0v/Off	VENTMIN to VENTMAX	Closed
		ON	ON	HIGH	24v/On	24v/On	VENTMIN to VENTMAX	Closed
	Yes	OFF	OFF	LOW	0v/Off	0v/Off	VENTMIN to VENTMAX	Closed
		ON	OFF	LOW	0v/Off	0v/Off	VENTMIN to Full-Open	Closed to Full-Open
		ON	ON	HIGH	DELAY* 24v/On	0v/Off*	VENTMIN to Full-Open	Closed to Full-Open

*With 2SP FAN DELAY (Advanced Setup Menu) when in the economizing mode there is a delay for the high speed fan to try to satisfy the call for second stage cooling by turning on the fan to high and opening the OA damper 100% before the first stage mechanical cooling is enabled.

†With stage 3 delay (STG3 DLY) in Advanced setup menu can turn on second stage of mechanical cooling Y2-O after the delay if the call for Y1-I and Y2-I have not been satisfied.

ENTHALPY SETTINGS

When the OA temperature, enthalpy and dew point are below the respective set points, the Outdoor Air can be used for economizing. Figure 66 shows the new single enthalpy boundaries in the W7220. There are 5 boundaries (set points ES1 through ES5), which are defined by dry bulb temperature, enthalpy and dew point.

Refer to Table 26 for ENTH CURVE set point values.

The W7220 calculates the enthalpy and dew point using the OA temperature and humidity input from the OA enthalpy sensor. When the OA temperature, OA humidity and OA dew point are all below the selected boundary, the economizer sets the economizing mode to YES, economizing is available.

When all of the OA conditions are above the selected boundary, the conditions are not good to economize and the mode is set to NO.

Figure 66 shows the 5 current boundaries. There is also a high limit boundary for differential enthalpy. The high limit boundary is ES1 when there are no stages of mechanical cooling energized and HL (high limit) when a compressor stage is energized.

TWO-SPEED FAN OPERATION

The W7220 controller has the capability to work with a system using a 2-speed supply fan. The W7220 does not control the supply directly but uses the following input status to determine the speed of the supply fan and controls the OA damper to the required position, see Table 25.

Table 25 — Fan Speed

STATE	FAN SPEED
OCC	Low
Y1	Low
Y2	High
W	High

The W (heating mode) is not controlled by the W7220 but it requires the status to know where to position the OA damper for minimum position for the fan speed.

The 2-speed fan delay is available when the system is programmed for 2-speed fan (in the System Setup menu item). The 2-speed fan delay is defaulted to 5 minutes and can be changed in the Advanced Setup menu item. When the unit has a call for Y1 In and in the free cooling mode and there is a call for Y2 In, the 2-speed fan delay starts and the OA damper will modulate 100% open, the supply fan should be set to high speed by the unit controller.

After the delay, one of two actions will happen:

- The Y2 In call will be satisfied with the damper 100% open and fan on high speed and the call will turn off

OR

- If the call for additional cooling in the space has not been satisfied, then the first stage of mechanical cooling will be enabled through Y1 Out or Y2 Out.

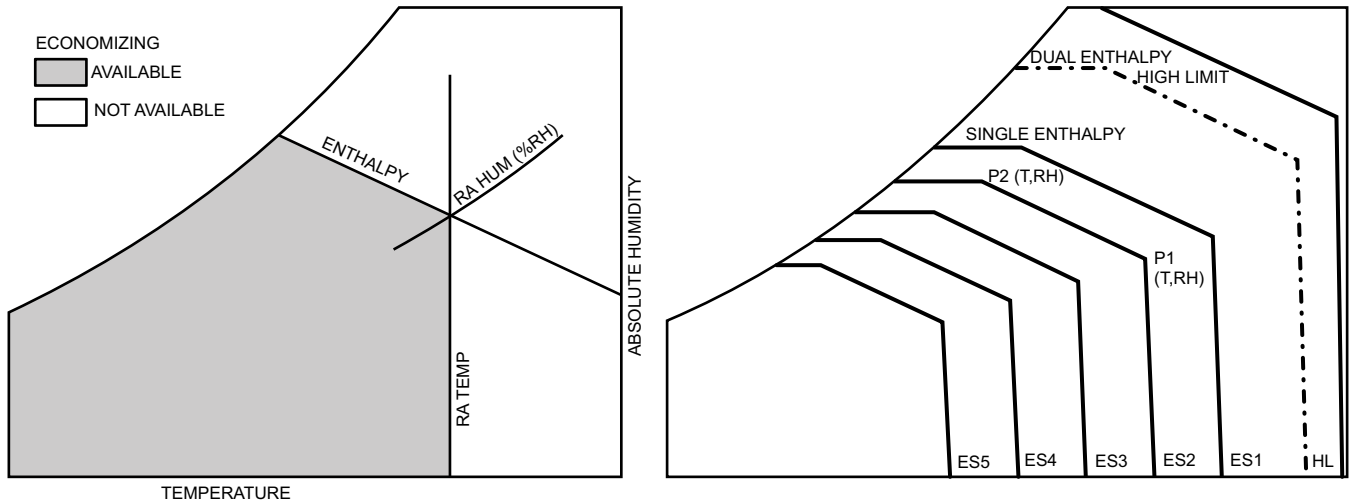

Fig. 66 — Single Enthalpy Curve Boundaries

Table 26 — Single Enthalpy and Dual Enthalpy High Limit Curves

ENTHALPY CURVE	TEMP. DRY BULB (F)	TEMP. DEWPOINT (F)	ENTHALPY (btu/lb/da)	POINT P1		POINT P2	
				TEMP. (F)	HUMIDITY (%RH)	TEMP. (F)	HUMIDITY (%RH)
ES1	80	60	28.0	80	36.8	66.3	80.1
ES2	75	57	26.0	75	39.6	63.3	80.0
ES3	70	54	24.0	70	42.3	59.7	81.4
ES4	65	51	22.0	65	44.8	55.7	84.2
ES5	60	48	20.0	60	46.9	51.3	88.5
HL	86	66	32.4	86	38.9	72.4	80.3

CHECKOUT

Inspect all wiring connections at the economizer module’s terminals, and verify compliance with the installation wiring diagrams. For checkout, review the Status of each configured parameter and perform the Checkout tests.

NOTE: For information about menu navigation and use of the keypad, see Interface Overview on page 45.

Power Up

After the W7220 module is mounted and wired, apply power.

Initial Menu Display

On initial start up, Honeywell displays on the first line and economizer W7220 on the second line. After a brief pause, the revision of the software appears on the first line and the second line will be blank.

Power Loss (Outage or Brownout)

All set points and advanced settings are restored after any power loss or interruption.

NOTE: All settings are stored in non-volatile flash memory.

Status

Use the Status menu (see Table 15) to check the parameter values for the various devices and sensors configured.

NOTE: For information about menu navigation and use of the keypad, see Interface Overview on page 45.

Checkout Tests

Use the Checkout menu (see page 49) to test the damper operation and any configured outputs. Only items that are configured are shown in the Checkout menu.

NOTE: For information about menu navigation and use of the keypad, see Interface Overview on page 45.

To perform a Checkout test:

1. Scroll to the desired test in the Checkout menu using the ▲ and ▼ buttons.
2. Press the ↵ (Enter) button to select the item. RUN? appears.
3. Press the ↵ (Enter) button to start the test. The unit pauses and then displays IN PROGRESS. When the test is complete, DONE appears.
4. When all desired parameters have been tested, press the ⬆ (Menu Up) button to end the test.

The Checkout tests can all be performed at the time of installation or at any time during the operation of the system as a test that the system is operable.

⚠ CAUTION

EQUIPMENT DAMAGE HAZARD

Failure to follow this caution may result in equipment damage. Be sure to allow enough time for compressor start-up and shutdown between checkout tests so that you do not short-cycle the compressors.

TROUBLESHOOTING

Alarms

The economizer module provides alarm messages that display on the 2-line LCD.

NOTE: Upon power up, the module waits 60 minutes before checking for alarms. This allows time for all the configured devices (e.g. sensors, actuator) to become operational. The exception is the SAT sensor which will alarm immediately.



If one or more alarms are present and there has been no keypad activity for at least 5 minutes, the Alarms menu displays and cycles through the active alarms.

You can also navigate to the Alarms menu at any time.

Clearing Alarms

Once the alarm has been identified and the cause has been removed (e.g. replaced faulty sensor) the alarm can be cleared from the display.

To clear an alarm, perform the following:

1. Navigate to the desired alarm.
2. Press the  (Enter) button. ERASE? displays.
3. Press the  (Enter) button. ALARM ERASED displays.
4. Press the  (Menu up/Exit) button to complete the action and return to the previous menu.

If the alarm still exists after clearing it, it is redisplayed within 5 seconds.

PRE-START-UP/START-UP

WARNING

PERSONAL INJURY HAZARD

Failure to follow this warning could result in personal injury or death.

1. Follow recognized safety practices and wear approved Personal Protective Equipment (PPE), including safety glasses and gloves when checking or servicing refrigerant system.
2. Do not use a torch to remove any component. System contains oil and refrigerant under pressure. To remove a component, wear PPE and proceed as follows:
 - a. Shut off all electrical power to unit. Apply applicable lockout/tag-out procedures.
 - b. Recover refrigerant to relieve all pressure from system using both high-pressure and low pressure ports.
 - c. Do not use a torch. Cut component connection tubing with tubing cutter and remove component from unit.
 - d. Carefully un-sweat remaining tubing stubs when necessary. Oil can ignite when exposed to torch flame.
3. Do not operate compressor or provide any electric power to unit unless compressor terminal cover is in place and secured.
4. Do not remove compressor terminal cover until all electrical power is disconnected and approved lockout/tag-out procedures are in place.
5. Relieve all pressure from system before touching or disturbing anything inside terminal box whenever refrigerant leak is suspected around compressor terminals.
6. Never attempt to repair a soldered connection while refrigerant system is under pressure.

WARNING

ELECTRICAL OPERATION HAZARD

Failure to follow this warning could result in personal injury or death.

The unit must be electrically grounded in accordance with local codes and NEC ANSI/NFPA 70 (American National Standards Institute/National Fire Protection Association).

Proceed as follows to inspect and prepare the unit for initial start-up:

1. Remove all access panels.
2. Read and follow instructions on all WARNING, CAUTION, and INFORMATION labels attached to, or shipped with, unit.
3. Make the following inspections:
 - a. Inspect for shipping and handling damages such as broken lines, loose parts, or disconnected wires, etc.
 - b. Inspect for oil at all refrigerant tubing connections and on unit base. Detecting oil generally indicates a refrigerant leak. Leak-test all refrigerant tubing connections using electronic leak detector, halide torch, or liquid-soap solution.
 - c. Inspect all field-wiring and factory-wiring connections. Be sure that connections are completed and tight. Be sure that wires are not in contact with refrigerant tubing or sharp edges.
 - d. Inspect coil fins. If damaged during shipping and handling, carefully straighten fins with a fin comb.
4. Verify the following conditions:
 - a. Make sure that condenser-fan blade are correctly positioned in fan orifice. See Condenser-Fan Adjustment section for more details.
 - b. Make sure that air filter(s) is in place.
 - c. Make sure that condensate drain trap is filled with water to ensure proper drainage.
 - d. Make sure that all tools and miscellaneous loose parts have been removed.

START-UP, GENERAL

Unit Preparation

Make sure that unit has been installed in accordance with installation instructions and applicable codes.

IMPORTANT: Follow the base unit's start-up sequence as described in the unit's installation instructions.

In addition to the base unit start-up, there are a few steps needed to properly start-up the controls. RTU-OPEN's Service Test function should be used to assist in the base unit start-up and also allows verification of output operation. Controller configuration is also part of start-up. This is especially important when field accessories have been added to the unit. The factory pre-configures options installed at the factory. There may also be additional installation steps or inspection required during the start-up process.

Additional Installation/Inspection

Inspect the field installed accessories for proper installation, making note of which ones do or do not require configuration changes. Inspect the RTU-OPEN's Alarms for initial insight to any potential issues. Refer to the following manual: "Controls, Start-up, Operation and Troubleshooting Instructions." Inspect the SAT sensor for relocation as intended during installation. Inspect special wiring as directed.

Return-Air Filters

Ensure correct filters are installed in unit (see Appendix B - Physical Data). Do not operate unit without return-air filters.

Outdoor-Air Inlet Screens

Outdoor-air inlet screen must be in place before operating unit.

Compressor Mounting

Compressors are internally spring mounted. Do not loosen or remove compressor hold down bolts.

Internal Wiring

Check all electrical connections in unit control boxes. Tighten as required.

Refrigerant Service Ports

Each unit system has two 1/4-in. SAE flare (with check valves) service ports: one on the suction line, and one on the compressor discharge line. Be sure that caps on the ports are tight.

Compressor Rotation

⚠ CAUTION

EQUIPMENT DAMAGE HAZARD

Failure to follow this caution can result in premature wear and damage to equipment.

Scroll compressors can only compress refrigerant if rotating in the right direction. Reverse rotation for extended times can result in internal damage to the compressor. Scroll compressors are sealed units and cannot be repaired on site location.

NOTE: When the compressor is rotating in the wrong direction, the unit will make an elevated level of noise and will not provide cooling.

On 3-phase units with scroll compressors, it is important to be certain compressor is rotating in the proper direction. To determine whether or not compressor is rotating in the proper direction:

1. Connect service gages to suction and discharge pressure fittings.
2. Energize the compressor.
3. The suction pressure should drop and the discharge pressure should rise, as is normal on any start-up.

If the suction pressure does not drop and the discharge pressure does not rise to normal levels:

1. Note that the evaporator fan is probably also rotating in the wrong direction.
2. Turn off power to the unit and install lockout tag.
3. Reverse any two of the unit power leads.
4. Reapply electrical power to the compressor.
5. The suction pressure should drop, and the discharge pressure should rise, which is normal for scroll compressors on start-up.
6. Replace the compressor if suction/discharge pressures are not within specifications for the specific compressor.

Cooling

Set space thermostat to OFF position. To start unit, turn on main power supply. Set system selector switch at COOL position and fan switch at AUTO position. Adjust thermostat to a setting below room temperature. Compressor starts on closure of contactor.

Check unit charge. Refer to Refrigerant Charge section.

Reset thermostat at a position above room temperature. Compressor will shut off. Evaporator fan will shut off after a 30 second delay.

To shut off unit, set system selector switch at OFF position. Resetting thermostat at a position above room temperature shuts unit off temporarily until space temperature exceeds thermostat setting.

NOTE: The default value for the evaporator-fan motor on/off delay is 45 seconds. Based upon unit operating conditions, the on delay can be reduced to 0 seconds and the off delay can be extended to 180 seconds. When one flash of the LED is observed, the evaporator-fan on/off delay has been modified.

Ventilation (Continuous Fan)

Set fan and system selector switches at ON and OFF positions, respectively. Evaporator fan operates continuously to provide constant air circulation. When the evaporator-fan selector switch is turned to the OFF position, there is a 30 second delay before the fan turns off.

START-UP, PREMIERLINK CONTROLS

NOTICE: SET-UP INSTRUCTIONS

All set-up and set point configurations are factory set and field-adjustable.

Refer to the PremierLink Installation, Start-Up and Configuration Instructions for specific operating instructions for the controller. Have a copy of this manual available at unit start-up.

START-UP, RTU-OPEN CONTROLS

NOTICE: SET-UP INSTRUCTIONS

Refer to the following manuals for additional installation, wiring and troubleshooting information for the RTU-OPEN Controller: "Controls, Start-up, Operation and Troubleshooting Instructions," "RTU Open Installation and Start-up Guide" and "RTU-Open Integration Guide". Have a copy of these manuals available at unit start-up.

FASTENER TORQUE VALUES

Table 27 — Torque Values

LOCATION	TORQUE VALUES
Supply fan motor mounting	120 in.-lb (13.6 Nm) ± 12 in.-lb (1.4Nm)
Supply fan motor adjustment plate	120 in.-lb (13.6 Nm) ± 12 in.-lb (1.4Nm)
Motor pulley setscrew	72 in.-lb (8.1 Nm) ± 5 in.-lb (0.6 Nm)
Fan pulley setscrew	72 in.-lb (8.1 Nm) ± 5 in.-lb (0.6 Nm)
Blower wheel hub setscrew	72 in.-lb (8.1 Nm) ± 5 in.-lbs (0.6 Nm)
Bearing locking collar setscrew	50 in.-lb (6.2 Nm) -60 in.-lb (6.8 Nm)
Compressor mounting bolts	65 in.-lb (7.3 Nm) -75 in.-lb (8.5Nm)
Condenser fan motor mounting bolts	20 in.-lb (2.3 Nm) ± 2 in.-lb 0.2 Nm)
Condenser fan hub setscrew	84 in.-lb (9.5 Nm) ± 12 in.-lb (1.4 Nm)

APPENDIX A — MODEL NUMBER NOMENCLATURE

Position:	1	2	3	4	5	6	7	8	9	10	11	12	13	14	15	16	17	18
Example:	5	0	T	C	-	D	2	4	A	1	G	6	-	0	A	0	A	0

Unit Heat Type
50 - Electric Heat
Packaged Rooftop

Model Series - WeatherMaker®
TC - Standard Efficiency

Heat Options
- = No Heat

Refrig. Systems Options
D = Two stage cooling model
E = Two stage cooling models with Humidi-MiZer®
(17-28 models with RTPF coils only)

Cooling Tons
17 = 15 tons 28 = 25 tons
20 = 17.5 tons 30 = 27.5 tons
24 = 20 tons

Sensor Options
A = None
B = RA Smoke Detector
C = SA Smoke Detector
D = RA + SA Smoke Detector
E = CO₂
F = RA Smoke Detector and CO₂
G = SA Smoke Detector and CO₂
H = RA + SA Smoke Detector and CO₂

Indoor Fan Options and Air Flow Configuration
1 = Standard Static/Vertical Supply, Return Air Flow
2 = Medium Static/Vertical Supply, Return Air Flow
3 = High Static/Vertical Supply, Return Air Flow
B = Med Static High Efficiency Motor/Vertical Supply, Return Air Flow
C = High Static High Efficiency Motor/Vertical Supply, Return Air Flow

Coil Options – RTPF (Outdoor – Indoor – Hail Guard)
A = Al/Cu – Al/Cu
B = Precoat Al/Cu – Al/Cu
C = E-coat Al/Cu – Al/Cu
D = E-coat Al/Cu – E-coat Al/Cu
E = Cu/Cu – Al/Cu
F = Cu/Cu – Cu/Cu
M = Al/Cu – Al/Cu – Louvered Hail Guard
N = Precoat Al/Cu – Al/Cu – Louvered Hail Guard
P = E-coat Al/Cu – Al/Cu – Louvered Hail Guard
Q = E-coat Al/Cu – E-coat Al/Cu – Louvered Hail Guard
R = Cu/Cu – Al/Cu – Louvered Hail Guard
S = Cu/Cu – Cu/Cu – Louvered Hail Guard

Coil Options – Novation® (Outdoor – Indoor – Hail Guard)
G = Al/Al – Al/Cu
H = Al/Al – Cu/Cu
J = Al/Al – E-coat Al/Cu
K = E-coat Al/Al – Al/Cu
L = E-coat Al/Al – E-coat Al/Cu
T = Al/Al – Al/Cu – Louvered Hail Guard
U = Al/Al – Cu/Cu – Louvered Hail Guard
V = Al/Al – E-coat Al/Cu – Louvered Hail Guard
W = E-coat Al/Al – Al/Cu – Louvered Hail Guard
X = E-coat Al/Al – E-coat Al/Cu – Louvered Hail Guard

Packaging & Seismic Compliance
0 = Standard
3 = California Seismic Compliant

Electrical Options
A = None
C = Non-Fused Disconnect
G = 2-Speed Indoor Fan (VFD) Controller
J = 2 Speed Fan Controller (VFD) and Non-Fused Disconnect

Service Options
0 = None
1 = Unpowered Convenience Outlet
2 = Powered Convenience Outlet
3 = Hinged Panels
4 = Hinged Panels and Unpowered Convenience Outlet
5 = Hinged Panels and Powered Convenience Outlet

Intake / Exhaust Options
A = None
B = Temperature Economizer w/ Barometric Relief
F = Enthalpy Economizer w/ Barometric Relief
K = 2-Position Damper
U = Temp Ultra Low Leak Economizer w/ Baro Relief
V = Temp Ultra Low Leak Economizer w/ PE (cert) - Vertical Air Only
W = Enthalpy Ultra Low Leak Economizer w/ Baro Relief
X = Enthalpy Ultra Low Leak Economizer PE (cert) - Vertical Air Only

Base Unit Controls
0 = Base Electromechanical Controls
1 = PremierLink Controller*
2 = RTU Open Multi-Protocol Controller
6 = Electro-mechanical w/ 2-Speed Fan and W7220 Economizer Controller

Design Revision
- = Factory Design Revision

Voltage
1 = 575/3/60
5 = 208-230/3/60
6 = 460/3/60

*PremierLink™ controller cannot be used with Staged Air Volume (SAV™) 2-speed indoor fan motor

Fig. A — Model Number Nomenclature (Vertical Units)

APPENDIX A — MODEL NUMBER NOMENCLATURE

Position:	1	2	3	4	5	6	7	8	9	10	11	12	13	14	15	16	17	18
Example:	5	0	T	C	-	D	2	5	A	5	A	5	-	0	A	0	A	0

Unit Heat Type

50 - Electric Heat Packaged Rooftop

Model Series - WeatherMaker®

TC - Standard Efficiency

Heat Options

- = Standard, No Electric Heat

Refrig. Systems Options

D = Two stage cooling model

E = Two stage cooling models with Humidi-MiZer® System

Cooling Tons

18 = 15 tons

21 = 17.5 tons

25 = 20 tons

29 = 25 tons

Sensor Options

A = None

B = RA Smoke Detector

C = SA Smoke Detector

D = RA + SA Smoke Detector

E = CO₂

F = RA Smoke Detector and CO₂

G = SA Smoke Detector and CO₂

H = RA + SA Smoke Detector and CO₂

J = Condensate Overflow Switch (electro-mechanical controls only)

K = Condensate Overflow Switch and RA Smoke Detectors

L = Condensate Overflow Switch and RA and SA Smoke Detectors

Indoor Fan Options and Air Flow Configuration

5 = Standard Static/Horizontal Supply, Return Air Flow
(not available in 29 size models with 1-speed motors)

6 = Medium Static/Horizontal Supply, Return Air Flow
(not available in 29 size models with 1-speed motors)

7 = High Static/Horizontal Supply, Return Air Flow
(not available in 29 size models with 1-speed motors)

F = Medium Static High Efficiency Motor/Horizontal Supply, Return Air Flow
(not available in 29 size models)

G = High Static High Efficiency Motor/Horizontal Supply, Return Air Flow
(not available in 29 size models)

Coil Options – RTPF (Outdoor – Indoor – Hail Guard)

A = Al/Cu – Al/Cu

B = Precoat Al/Cu – Al/Cu

C = E-coat Al/Cu – Al/Cu

D = E-coat Al/Cu – E-coat Al/Cu

E = Cu/Cu – Al/Cu

F = Cu/Cu – Cu/Cu

M = Al/Cu – Al/Cu – Louvered Hail Guard

N = Precoat Al/Cu – Al/Cu – Louvered Hail Guard

P = E-coat Al/Cu – Al/Cu – Louvered Hail Guard

Q = E-coat Al/Cu – E-coat Al/Cu – Louvered Hail Guard

R = Cu/Cu – Al/Cu – Louvered Hail Guard

S = Cu/Cu – Cu/Cu – Louvered Hail Guard

Packaging and Seismic Compliance

0 = Standard

Electrical Options

A = Non USA models – No (SAV) included

C = Non-Fused Disconnect

G = Standard USA models – (SAV) included

2-Speed Indoor Fan (VFD) Controller

J = 2 Speed Fan Controller (VFD) and

Non-Fused Disconnect

Service Options

0 = None

1 = Unpowered Convenience Outlet

2 = Powered Convenience Outlet

3 = Hinged Panels

4 = Hinged Panels and
Unpowered Convenience Outlet

5 = Hinged Panels and
Powered Convenience Outlet

Intake / Exhaust Options

A = None

B = Temperature Economizer w/ Barometric Relief

F = Enthalpy Economizer w/ Barometric Relief

K = 2-Position Damper

U = Temp Ultra Low Leak Economizer w/ Baro Relief

W = Enthalpy Ultra Low Leak Economizer w/ Baro Relief

Base Unit Controls

0 = Electro-mechanical controls. Can be used with
W7212 EconoMiSer® IV (Non-Fault Detection and
Diagnostic)

1 = PremierLink™ Controller

2 = RTU Open Multi-Protocol Controller

6 = Electro-mechanical controls. Can be used with
W7220 EconoMiSer X (with Fault Detection and
Diagnostic)

D = ComfortLink Controls

Design Revision

- = Factory Design Revision

Voltage

1 = 575/3/60

5 = 208-230/3/60

6 = 460/3/60

NOTE: Not all possible options are displayed. See the current
50TC Horizontal 15 to 25 Ton Price Pages for more details.

Fig. B — Model Number Nomenclature (Horizontal Units)

APPENDIX B — PHYSICAL DATA

Table A — Physical Data - Vertical (Cooling) 15 To 25 Tons (Novation Coils)

		50TC-D17	50TC-D20	50TC-D24	50TC-D28
REFRIGERATION SYSTEM		MCHX	MCHX	MCHX	MCHX
	# Circuits / # Comp. / Type	2 / 2 / Scroll	2 / 2 / Scroll	2 / 2 / Scroll	2 / 2 / Scroll
	R-410A charge A/B (lbs)	9.5/12.0	9.5/12.0	14.4/12.5	12.5/13.0
	Metering device	Acutrol	Acutrol	Acutrol	Acutrol
	High-press. Trip / Reset (psig)	630 / 505	630 / 505	630 / 505	630 / 505
	Low-press. Trip / Reset (psig)	54 / 117	54 / 117	54 / 117	54 / 117
EVAP. COIL					
	Material	Cu / Al	Cu / Al	Cu / Al	Cu / Al
	Tube diameter	3/8-in.	3/8-in.	3/8-in.	3/8-in.
	Rows / FPI	4 / 15	4 / 15	4 / 15	4 / 15
	Total face area (ft ²)	19.56	19.56	22.00	23.11
	Condensate drain conn. size	3/4-in.	3/4-in.	3/4-in.	3/4-in.
EVAP. FAN AND MOTOR					
Standard Static	Motor qty / Belt qty / Drive type	1 / 1 /Belt	1 / 1 /Belt	1 / 1 /Belt	1 / 1 /Belt
	Nominal nameplate HP	2.9	3.7	5.25	5.25
	Max BHP	2.9	3.7	4.9	4.9
	RPM Range	514-680	622-822	690-863	717-911
	Max blower / shaft RPM	1200	1200	1200	1200
	Motor frame size	56	56	56	56
	Fan qty / Type	2 / Centrifugal	2 / Centrifugal	2 / Centrifugal	2 / Centrifugal
	Fan diameter (in.)	15 x 15	15 x 15	15 x 15	15 x 15
Medium Static	Motor qty / Belt qty / Drive type	1 / 1/ Belt	—	—	—
	Nominal nameplate HP	3.7	—	—	—
	Max BHP	3.7	—	—	—
	RPM Range	679-863	—	—	—
	Max blower / shaft RPM	1200	—	—	—
	Motor frame size	56	—	—	—
	Fan qty / Type	2 / Centrifugal	—	—	—
	Fan diameter (in.)	15 x 15	—	—	—
High Static	Motor qty / Belt qty / Drive type	1 / 1/ Belt	—	—	—
	Nominal nameplate HP	5.25	—	—	—
	Max BHP	4.9	—	—	—
	RPM Range	826-1009	—	—	—
	Max blower / shaft RPM	1200	—	—	—
	Motor frame size	56	—	—	—
	Fan qty / Type	2 / Centrifugal	—	—	—
	Fan diameter (in.)	15 x 15	—	—	—
Medium Static - High Efficiency	Motor qty / Belt qty / Drive type	—	1 / 1/ Belt	1 / 1/ Belt	1 / 1/ Belt
	Nominal nameplate HP	—	5.0	5.0	5.0
	Max BHP (208/230/460/575v)	—	6.5/ 6.9/ 7.0/ 8.3	6.5/ 6.9/ 7.0/ 8.3	6.5/ 6.9/ 7.0/ 8.3
	RPM Range	—	713-879	835-1021	913-1116
	Max blower / shaft RPM	—	1200	1200	1200
	Motor frame size	—	184T	184T	184T
	Fan qty / Type	—	2 / Centrifugal	2 / Centrifugal	2 / Centrifugal
	Fan diameter (in.)	—	15 x 15	15 x 15	15 x 15
High Static - High Efficiency	Motor qty / Belt qty / Drive type	—	1 / 1/ Belt	1 / 1/ Belt	1 / 1/ Belt
	Nominal nameplate HP	—	5.0	7.5	7.5
	Max BHP (208/230/460/575v)	—	6.5/ 6.9/ 7.0/ 8.3	10.5/11.9/11.9/11	10.5/11.9/11.9/11
	RPM Range	—	882-1078	941-1176	941-1176
	Max blower / shaft RPM	—	1200	1200	1200
	Motor frame size	—	184T	213T	213T
	Fan qty / Type	—	2 / Centrifugal	2 / Centrifugal	2 / Centrifugal
	Fan diameter (in.)	—	15 x 15	15 x 15	15 x 15
COND. COIL (CIRCUIT A)					
	Coil type	Novation	Novation	Novation	Novation
	Coil length (in.)	70	70	82	75
	Coil height (in.)	44	44	44	52
	Rows / FPI	1 / 20.3	1 / 20.3	1 / 20.3	1 / 20.3
	Total face area (ft ²)	21.4	21.4	25.1	27.1

APPENDIX B — PHYSICAL DATA

Table A — Physical Data - Vertical (Cooling) 15 To 25 Tons (Novation Coils) (cont)

	50TC-D17	50TC-D20	50TC-D24	50TC-D28
COND. COIL (CIRCUIT B)				
Coil type	Novation	Novation	Novation	Novation
Coil length (in.)	70	70	57	75
Coil height (in.)	44	44	44	52
Rows / FPI	1 / 20.3	1 / 20.3	1 / 20.3	1 / 20.3
Total face area (ft ²)	21.4	21.4	17.4	27.1
COND. FAN / MOTOR				
Qty / Motor drive type	3 / direct	3 / direct	4 / direct	4 / direct
Motor HP / RPM	1/4 / 1100	1/4 / 1100	1/4 / 1100	1/4 / 1100
Fan diameter (in.)	22	22	22	22
FILTERS				
RA filter # / size (in.)	6 / 20 x 25 x 2	6 / 20 x 25 x 2	6 / 20 x 25 x 2	9 / 16 x 25 x 2
OA inlet screen # / size (in.)	4 / 16 x 25 x 1	4 / 16 x 25 x 1	4 / 16 x 25 x 1	4 / 16 x 25 x 1



APPENDIX B — PHYSICAL DATA

Table B — Physical Data - Vertical (Cooling) 15 To 17.5 Tons (RTPF Coils)

		50TC-D17	50TC-E17	50TC-D20	50TC-E20
REFRIGERATION SYSTEM		RTPF	RTPF	RTPF	RTPF
# Circuits / # Comp. / Type		2 / 2 / Scroll	2 / 2 / Scroll	2 / 2 / Scroll	2 / 2 / Scroll
R-410A charge A/B (lbs)		16.3/17.5	25.9/25.7	16.3/17.5	25.9/25.7
Metering device		Acutrol	TXV	Acutrol	TXV
High-press. Trip / Reset (psig)		630 / 505	630 / 505	630 / 505	630 / 505
Low-press. Trip / Reset (psig)		54 / 117	27 / 44	54 / 117	27 / 44
EVAP. COIL					
Material		Cu / Al	Cu / Al	Cu / Al	Cu / Al
Tube diameter		3/8-in.	3/8-in.	3/8-in.	3/8-in.
Rows / FPI		4 / 15	4 / 15	4 / 15	4 / 15
Total face area (ft ²)		22.00	22.00	22.00	22.00
Condensate drain conn. size		3/4-in.	3/4-in.	3/4-in.	3/4-in.
HUMIDIFIER COIL					
Material		—	Cu / Al	—	Cu / Al
Tube diameter		—	3/8-in.	—	3/8-in.
Rows / FPI		—	1 / 17	—	1 / 17
Total face area (ft ²)		—	22.00	—	22.00
EVAP. FAN AND MOTOR					
Standard Static	Motor qty / Belt qty / Drive type	1 / 1 /Belt	1 / 1 /Belt	1 / 1 /Belt	1 / 1 /Belt
	Nominal nameplate HP	2.9	2.9	3.7	3.7
	Max BHP	2.9	2.9	3.7	3.7
	RPM Range	514-680	514-680	622-822	622-822
	Max blower / shaft RPM	1200	1200	1200	1200
	Motor frame size	56	56	56	56
	Fan qty / Type	2 / Centrifugal	2 / Centrifugal	2 / Centrifugal	2 / Centrifugal
Fan diameter (in.)	15 x 15	15 x 15	15 x 15	15 x 15	
Medium Static	Motor qty / Belt qty / Drive type	1 / 1/ Belt	1 / 1/ Belt	1 / 1/ Belt	1 / 1/ Belt
	Nominal nameplate HP	3.7	3.7	5.25	5.25
	Max BHP	3.7	3.7	4.9	4.9
	RPM Range	679-863	679-863	713-879	713-879
	Max blower / shaft RPM	1200	1200	1200	1200
	Motor frame size	56	56	56	56
	Fan qty / Type	2 / Centrifugal	2 / Centrifugal	2 / Centrifugal	2 / Centrifugal
Fan diameter (in.)	15 x 15	15 x 15	15 x 15	15 x 15	
High Static	Motor qty / Belt qty / Drive type	1 / 1/ Belt	1 / 1/ Belt	—	—
	Nominal nameplate HP	5.25	5.25	—	—
	Max BHP	4.9	4.9	—	—
	RPM Range	826-1009	826-1009	—	—
	Max blower / shaft RPM	1200	1200	—	—
	Motor frame size	56	56	—	—
	Fan qty / Type	2 / Centrifugal	2 / Centrifugal	—	—
Fan diameter (in.)	15 x 15	15 x 15	—	—	
Medium Static - High Efficiency	Motor qty / Belt qty / Drive type	—	—	1 / 1/ Belt	1 / 1/ Belt
	Nominal nameplate HP	—	—	5.0	5.0
	Max BHP (208/230/460/575v)	—	—	6.5/ 6.9/ 7.0/ 8.3	6.5/ 6.9/ 7.0/ 8.3
	RPM Range	—	—	713-879	713-879
	Max blower / shaft RPM	—	—	1200	1200
	Motor frame size	—	—	184T	184T
	Fan qty / Type	—	—	2 / Centrifugal	2 / Centrifugal
Fan diameter (in.)	—	—	15 x 15	15 x 15	
High Static - High Efficiency	Motor qty / Belt qty / Drive type	—	—	1 / 1/ Belt	1 / 1/ Belt
	Nominal nameplate HP	—	—	5.0	5.0
	Max BHP (208/230/460/575v)	—	—	6.5/ 6.9/ 7.0/ 8.3	6.5/ 6.9/ 7.0/ 8.3
	RPM Range	—	—	882-1078	882-1078
	Max blower / shaft RPM	—	—	1200	1200
	Motor frame size	—	—	184T	184T
	Fan qty / Type	—	—	2 / Centrifugal	2 / Centrifugal
Fan diameter (in.)	—	—	15 x 15	15 x 15	

APPENDIX B — PHYSICAL DATA

Table B — Physical Data - Vertical (Cooling) 15 To 17.5 Tons (RTPF Coils) (cont)

	50TC-D17	50TC-E17	50TC-D20	50TC-E20
COND. COIL (CIRCUIT A)				
Coil type	RTPF	RTPF	RTPF	RTPF
Coil length (in.)	70	70	70	70
Coil height (in.)	44	44	44	44
Rows / FPI	2 / 17	2 / 17	2 / 17	2 / 17
Total face area (ft ²)	21.4	21.4	21.4	21.4
COND. COIL (CIRCUIT B)				
Coil type	RTPF	RTPF	RTPF	RTPF
Coil length (in.)	70	70	70	70
Coil height (in.)	44	44	44	44
Rows / FPI	2 / 17	2 / 17	2 / 17	2 / 17
Total face area (ft ²)	21.4	21.4	21.4	21.4
COND. FAN / MOTOR				
Qty / Motor drive type	3 / direct	3 / direct	3 / direct	3 / direct
Motor HP / RPM	1/4 / 1100	1/4 / 1100	1/4 / 1100	1/4 / 1100
Fan diameter (in.)	22	22	22	22
FILTERS				
RA filter # / size (in.)	6 / 20 x 25 x 2	6 / 20 x 25 x 2	6 / 20 x 25 x 2	6 / 20 x 25 x 2
OA inlet screen # / size (in.)	4 / 16 x 25 x 1	4 / 16 x 25 x 1	4 / 16 x 25 x 1	4 / 16 x 25 x 1



APPENDIX B — PHYSICAL DATA

Table C — Physical Data - Vertical (Cooling) 20 to 27.5 Tons (RTPF Coils)

		50TC-D24	50TC-E24	50TC-D28	50TC-E28	50TC-D30
REFRIGERATION SYSTEM		RTPF	RTPF	RTPF	RTPF	RTPF
# Circuits / # Comp. / Type		2 / 2 / Scroll	2 / 2 / Scroll	2 / 2 / Scroll	2 / 2 / Scroll	2 / 2 / Scroll
R-410A charge A/B (lbs)		20.6/14.7	27.9/20.5	19.8/ 20.4	27.9/ 28.9	27.0/ 28.5
Metering device		Acutrol	TXV	Acutrol	TXV	Acutrol
High-press. Trip / Reset (psig)		630 / 505	630 / 505	630 / 505	630 / 505	630 / 505
Low-press. Trip / Reset (psig)		54 / 117	27 / 44	54 / 117	27 / 44	54 / 117
EVAP. COIL						
Material		Cu / Al	Cu / Al	Cu / Al	Cu / Al	Cu / Al
Tube diameter		3/8-in.	3/8-in.	3/8-in.	3/8-in.	3/8-in.
Rows / FPI		4 / 15	4 / 15	4 / 15	4 / 15	4 / 15
Total face area (ft ²)		22.00	22.00	23.11	23.11	26
Condensate drain conn. size		3/4-in.	3/4-in.	3/4-in.	3/4-in.	3/4-in.
HUMIDI-MIZER COIL						
Material		—	Cu / Al	—	Cu / Al	—
Tube diameter		—	3/8-in.	—	3/8-in.	—
Rows / FPI		—	1 / 17	—	1 / 17	—
Total face area (ft ²)		—	22.00	—	23.11	—
EVAP. FAN AND MOTOR						
Standard Static	Motor qty / Belt qty / Drive type	1 / 1 /Belt	1 / 1 /Belt	1 / 1 /Belt	1 / 1 /Belt	—
	Nominal nameplate HP	5.25	5.25	5.25	5.25	—
	Max BHP	4.9	4.9	4.9	4.9	—
	RPM Range	690-863	690-863	717-911	717-911	—
	Max blower / shaft RPM	1200	1200	1200	1200	—
	Motor frame size	56	56	56	56	—
	Fan qty / Type	2 / Centrifugal	2 / Centrifugal	2 / Centrifugal	2 / Centrifugal	—
Fan diameter (in.)	15 x 15	15 x 15	15 x 15	15 x 15	—	
Standard Static - High Efficiency	Motor qty / Belt qty / Drive type	—	—	—	—	1 / 1 Belt
	Nominal nameplate HP	—	—	—	—	5.0
	Max BHP	—	—	—	—	6.5/ 6.9/ 7.0/ 8.3
	RPM Range	—	—	—	—	751-954
	Max blower / shaft RPM	—	—	—	—	1300
	Motor frame size	—	—	—	—	184T
	Fan qty / Type	—	—	—	—	2 / Centrifugal
Fan diameter (in.)	—	—	—	—	15 x 15	
Medium Static - High Efficiency	Motor qty / Belt qty / Drive type	1 / 1/ Belt	1 / 1/ Belt	1 / 1/ Belt	1 / 1/ Belt	1 / 1/ Belt
	Nominal nameplate HP	5.0	5.0	5.0	5.0	7.5
	Max BHP (208/230/460/575v)	6.5/ 6.9/ 7.0/ 8.3	6.5/ 6.9/ 7.0/ 8.3	6.5/ 6.9/ 7.0/ 8.3	6.5/ 6.9/ 7.0/ 8.3	10.5/11.9/11.9/11
	RPM Range	835-1021	835-1021	913-1116	913-1116	973-1175
	Max blower / shaft RPM	1200	1200	1200	1200	1300
	Motor frame size	184T	184T	184T	184T	184T
	Fan qty / Type	2 / Centrifugal	2 / Centrifugal	2 / Centrifugal	2 / Centrifugal	2 / Centrifugal
Fan diameter (in.)	15 x 15	15 x 15	15 x 15	15 x 15	15 x 15	
High Static - High Efficiency	Motor qty / Belt qty / Drive type	1 / 1/ Belt	1 / 1/ Belt	1 / 1/ Belt	1 / 1/ Belt	1 / 2/ Belt
	Nominal nameplate HP	7.5	7.5	7.5	7.5	10.0
	Max BHP (208/230/460/575v)	10.5/11.9/11.9/11	10.5/11.9/11.9/11	10.5/11.9/11.9/11	10.5/11.9/11.9/11	11.9/12.9/12.9/14.1
	RPM Range	941-1176	941-1176	941-1176	941-1176	1015-1299
	Max blower / shaft RPM	1200	1200	1200	1200	1300
	Motor frame size	213T	213T	213T	213T	213T
	Fan qty / Type	2 / Centrifugal	2 / Centrifugal	2 / Centrifugal	2 / Centrifugal	2 / Centrifugal
Fan diameter (in.)	15 x 15	15 x 15	15 x 15	15 x 15	15 x 15	
COND. COIL (CIRCUIT A)						
Coil type		RTPF	RTPF	RTPF	RTPF	RTPF
Coil length (in.)		82	82	75	75	95
Coil height (in.)		44	44	52	52	52
Rows / FPI		2 /17	2 /17	2 /17	2 /17	2 /17
Total face area (ft ²)		25.1	25.1	27.1	27.1	34.3

APPENDIX B — PHYSICAL DATA

Table C — Physical Data - Vertical (Cooling) 20 to 27.5 Tons (RTPF Coils) (cont)

	50TC-D24	50TC-E24	50TC-D28	50TC-E28	50TC-D30
COND. COIL (CIRCUIT B)					
Coil type	RTPF	RTPF	RTPF	RTPF	RTPF
Coil length (in.)	57	57	75	75	95
Coil height (in.)	44	44	52	52	52
Rows / FPI	2 / 17	2 / 17	2 / 17	2 / 17	2 / 17
Total face area (ft ²)	17.4	17.4	27.1	27.1	34.3
COND. FAN / MOTOR					
Qty / Motor drive type	4 / direct	4 / direct	4 / direct	4 / direct	6 / direct
Motor HP / RPM	1/4 / 1100	1/4 / 1100	1/4 / 1100	1/4 / 1100	1/4 / 1100
Fan diameter (in.)	22	22	22	22	22
FILTERS					
RA filter # / size (in.)	6 / 20 x 25 x 2	6 / 20 x 25 x 2	9 / 16 x 25 x 2	9 / 16 x 25 x 2	9 / 16 x 25 x 2
OA inlet screen # / size (in.)	4 / 16 x 25 x 1	4 / 16 x 25 x 1	4 / 16 x 25 x 1	4 / 16 x 25 x 1	4 / 16 x 25 x 1



APPENDIX B — PHYSICAL DATA

Table D — Physical Data - Horizontal (Cooling) 15 To 17.5 Tons (RTPF Coils)

		50TC-D18	50TC-E18	50TC-D21	50TC-E21
REFRIGERATION SYSTEM					
	# Circuits / # Comp. / Type	2 / 2 / Scroll	2 / 2 / Scroll	2 / 2 / Scroll	2 / 2 / Scroll
	R-410A charge A/B (lbs)	17/16.4	24.5/25.7	17.5/16.8	25.5/25.5
	Metering device	TXV	TXV	TXV	TXV
	High-press. Trip / Reset (psig)	630 / 505	630 / 505	630 / 505	630 / 505
	Low-press. Trip / Reset (psig)	54 / 117	27 / 44	54 / 117	27 / 44
EVAP. COIL					
	Material	Cu / Al	Cu / Al	Cu / Al	Cu / Al
	Tube diameter	3/8-in. RTPF	3/8-in. RTPF	3/8-in. RTPF	3/8-in. RTPF
	Rows / FPI	4 / 15	4 / 15	4 / 15	4 / 15
	Total face area (ft ²)	22	22	22	22
	Condensate drain conn. size	3/4-in.	3/4-in.	3/4-in.	3/4-in.
HUMIDIFIER COIL					
	Material	—	Cu / Al	—	Cu / Al
	Tube diameter	—	3/8-in. RTPF	—	3/8-in. RTPF
	Rows / FPI	—	1 / 17	—	1 / 17
	Total face area (ft ²)	—	22	—	22
EVAP. FAN AND MOTOR					
Standard Static	Motor qty / Belt qty / Drive type	1 / 1 /Belt	1 / 1 /Belt	1 / 1 /Belt	1 / 1 /Belt
	Nominal nameplate HP	2.9	2.9	3.7	3.7
	Max BHP	2.9	2.9	3.7	3.7
	RPM Range	514-680	514-680	622-822	622-822
	Max blower / shaft RPM	1100	1100	1100	1100
	Motor frame size	56	56	56	56
	Fan qty / Type	2 / Centrifugal	2 / Centrifugal	2 / Centrifugal	2 / Centrifugal
	Fan diameter (in.)	18 x 15/15 X 11	18 x 15/15 X 11	18 x 15/15 X 11	18 x 15/15 X 11
Medium Static	Motor qty / Belt qty / Drive type	1 / 1 /Belt	1 / 1 /Belt	1 / 1 /Belt	1 / 1 /Belt
	Nominal nameplate HP	3.7	3.7	5.25	5.25
	Max BHP	3.7	3.7	4.9	4.9
	RPM Range	614-780	614-780	713-879	713-879
	Max blower / shaft RPM	1100	1100	1100	1100
	Motor frame size	56	56	56	56
	Fan qty / Type	2 / Centrifugal	2 / Centrifugal	2 / Centrifugal	2 / Centrifugal
	Fan diameter (in.)	18 x 15/15 X 11	18 x 15/15 X 11	18 x 15/15 X 11	18 x 15/15 X 11
High Static	Motor qty / Belt qty / Drive type	1 / 1 /Belt	1 / 1 /Belt	—	—
	Nominal nameplate HP	5.25	5.25	—	—
	Max BHP	4.9	4.9	—	—
	RPM Range	746-912	746-912	—	—
	Max blower / shaft RPM	1100	1100	—	—
	Motor frame size	56	56	—	—
	Fan qty / Type	2 / Centrifugal	2 / Centrifugal	—	—
	Fan diameter (in.)	18 x 15/15 X 11	18 x 15/15 X 11	—	—
High Static - High Efficiency	Motor qty / Belt qty / Drive type	—	—	1 / 1 /Belt	1 / 1 /Belt
	Nominal nameplate HP	—	—	5.0	5.0
	Max BHP (208/230/460/575v)	—	—	6.5/ 6.9/ 7.0/ 8.3	6.5/ 6.9/ 7.0/ 8.3
	RPM Range	—	—	882-1078	882-1078
	Max blower / shaft RPM	—	—	1100	1100
	Motor frame size	—	—	184T	184T
	Fan qty / Type	—	—	2 / Centrifugal	2 / Centrifugal
	Fan diameter (in.)	—	—	18 x 15/15 X 11	18 x 15/15 X 11
COND. COIL (CIRCUIT A)					
	Coil type	RTPF	RTPF	RTPF	RTPF
	Coil length (in.)	70	70	72	72
	Coil height (in.)	44	44	44	44
	Rows / FPI	2 /17	2 /17	2 /17	2 /17
	Total face area (ft ²)	21.4	21.4	22.0	22.0

APPENDIX B — PHYSICAL DATA

Table D — Physical Data - Horizontal (Cooling) 15 To 17.5 Tons (RTPF Coils) (cont)

	50TC-D18	50TC-E18	50TC-D21	50TC-E21
COND. COIL (CIRCUIT B)				
Coil type	RTPF	RTPF	RTPF	RTPF
Coil length (in.)	70	70	64	64
Coil height (in.)	44	44	44	44
Rows / FPI	2 /17	2 /17	2 /17	2 /17
Total face area (ft ²)	21.4	21.4	19.5	19.5
COND. FAN / MOTOR				
Qty / Motor drive type	3 / direct	3 / direct	4 / direct	4 / direct
Motor HP / RPM	1/4 / 1100	1/4 / 1100	1/4 / 1100	1/4 / 1100
Fan diameter (in.)	22	22	22	22
FILTERS				
RA filter # / size (in.)	6 / 20 x 25 x 2	6 / 20 x 25 x 2	6 / 20 x 25 x 2	6 / 20 x 25 x 2
OA inlet screen # / size (in.)	4 / 16 x 25 x 1	4 / 16 x 25 x 1	4 / 16 x 25 x 1	4 / 16 x 25 x 1



APPENDIX B — PHYSICAL DATA

Table E — Physical Data - Horizontal (Cooling) 20 To 25 Tons (RTPF Coils)

		50TC-D25	50TC-E25	50TC-D29	50TC-E29
REFRIGERATION SYSTEM					
	# Circuits / # Comp. / Type	2 / 2 / Scroll	2 / 2 / Scroll	2 / 2 / Scroll	2 / 2 / Scroll
	R-410A charge A/B (lbs)	23.8/23.1	30.0/30.7	24.9/27.7	35.1/35.4
	Metering device	TXV	TXV	TXV	TXV
	High-press. Trip / Reset (psig)	630 / 505	630 / 505	630 / 505	630 / 505
	Low-press. Trip / Reset (psig)	54 / 117	27 / 44	54 / 117	27 / 44
EVAP. COIL					
	Material	Cu / Al	Cu / Al	Cu / Al	Cu / Al
	Tube diameter	3/8-in. RTPF	3/8-in. RTPF	3/8-in. RTPF	3/8-in. RTPF
	Rows / FPI	4 / 15	4 / 15	4 / 15	4 / 15
	Total face area (ft ²)	26	26	26	26
	Condensate drain conn. size	3/4-in.	3/4-in.	3/4-in.	3/4-in.
HUMIDIFIER COIL					
	Material	—	Cu / Al	—	Cu / Al
	Tube diameter	—	3/8-in. RTPF	—	3/8-in. RTPF
	Rows / FPI	—	1 / 17	—	1 / 17
	Total face area (ft ²)	—	26	—	26
EVAP. FAN AND MOTOR					
Standard Static	Motor qty / Belt qty / Drive type	1 / 1 /Belt	1 / 1 /Belt	1 / 1 /Belt	1 / 1 /Belt
	Nominal nameplate HP	5.25	5.25	—	—
	Max BHP	4.9	4.9	4.9	4.9
	RPM Range	690-863	690-863	647-791	647-791
	Max blower / shaft RPM	1100	1100	—	—
	Motor frame size	56	56	56	56
Medium Static - High Efficiency	Fan qty / Type	2 / Centrifugal	2 / Centrifugal	2 / Centrifugal	2 / Centrifugal
	Fan diameter (in.)	18 x 15/15 X 11	18 x 15/15 X 11	18 x 15/15 X 11	18 x 15/15 X 11
	Motor qty / Belt qty / Drive type	1 / 1 /Belt	1 / 1 /Belt	1 / 1 /Belt	1 / 1 /Belt
	Nominal nameplate HP	5.0	5.0	5.0	5.0
	Max BHP (208/230/460/575v)	6.5/ 6.9/ 7.0/ 8.3	6.5/ 6.9/ 7.0/ 8.3	6.5/ 6.9/ 7.0/ 8.3	6.5/ 6.9/ 7.0/ 8.3
	RPM Range	835-1021	835-1021	755-923	755-923
High Static - High Efficiency	Max blower / shaft RPM	1100	1100	1100	1100
	Motor frame size	184T	184T	184T	184T
	Fan qty / Type	2 / Centrifugal	2 / Centrifugal	2 / Centrifugal	2 / Centrifugal
	Fan diameter (in.)	18 x 15/15 X 11	18 x 15/15 X 11	18 x 15/15 X 11	18 x 15/15 X 11
	Motor qty / Belt qty / Drive type	1 / 1 /Belt	1 / 1 /Belt	1 / 1 /Belt	1 / 1 /Belt
	Nominal nameplate HP	7.5	7.5	7.5	7.5
COND. COIL (CIRCUIT A)	Max BHP (208/230/460/575v)	10.5/11.9/11.9/11	10.5/11.9/11.9/11	10.5/11.9/11.9/11	10.5/11.9/11.9/11
	RPM Range	941-1100	941-1100	906-1100	906-1100
	Max blower / shaft RPM	1100	1100	1100	1100
	Motor frame size	213T	213T	213T	213T
	Fan qty / Type	2 / Centrifugal	2 / Centrifugal	2 / Centrifugal	2 / Centrifugal
	Fan diameter (in.)	18 x 15/15 X 11	18 x 15/15 X 11	18 x 15/15 X 11	18 x 15/15 X 11
COND. COIL (CIRCUIT B)					
	Coil type	RTPF	RTPF	RTPF	RTPF
	Coil length (in.)	82	82	95	95
	Coil height (in.)	52	52	52	52
	Rows / FPI	2 /17	2 /17	2 /17	2 /17
	Total face area (ft ²)	29.6	29.6	34.3	34.3
COND. COIL (CIRCUIT B)					
	Coil type	RTPF	RTPF	RTPF	RTPF
	Coil length (in.)	80	80	95	95
	Coil height (in.)	52	52	52	52
	Rows / FPI	2 /17	2 /17	2 /17	2 /17
	Total face area (ft ²)	29.6	29.6	34.3	34.3
COND. FAN / MOTOR					
	Qty / Motor drive type	4/ direct	4/ direct	6 / direct	6 / direct
	Motor HP / RPM	1/4 / 1100	1/4 / 1100	1/4 / 1100	1/4 / 1100
	Fan diameter (in.)	22	22	22	22
FILTERS					
	RA filter # / size (in.)	9 / 16 x 25 x 2	9 / 16 x 25 x 2	9 / 16 x 25 x 2	9 / 16 x 25 x 2
	OA inlet screen # / size (in.)	4 / 16 x 25 x 1	4 / 16 x 25 x 1	4 / 16 x 25 x 1	4 / 16 x 25 x 1

APPENDIX C — FAN DATA

Table F — 50TC-*17 Vertical Supply/Return (15 tons)

CFM	AVAILABLE EXTERNAL STATIC PRESSURE (in. wg)									
	0.2		0.4		0.6		0.8		1.0	
	RPM	BHP	RPM	BHP	RPM	BHP	RPM	BHP	RPM	BHP
4500	436	0.60	529	0.89	611	1.20	684	1.54	749	1.90
4900	458	0.72	546	1.02	625	1.36	696	1.72	760	2.09
5250	479	0.85	561	1.16	638	1.51	708	1.88	771	2.27
5650	503	1.01	580	1.33	654	1.70	721	2.09	784	2.50
6000	525	1.17	598	1.50	668	1.88	734	2.28	795	2.71
6400	551	1.38	619	1.72	686	2.11	750	2.53	810	2.97
6750	574	1.58	638	1.93	702	2.33	764	2.76	822	3.22
7150	601	1.84	661	2.20	722	2.61	781	3.06	838	3.53
7500	625	2.09	682	2.46	740	2.88	797	3.34	852	3.82

CFM	AVAILABLE EXTERNAL STATIC PRESSURE (in. wg)									
	1.2		1.4		1.6		1.8		2.0	
	RPM	BHP	RPM	BHP	RPM	BHP	RPM	BHP	RPM	BHP
4500	808	2.27	864	2.66	916	3.06	965	3.48	<i>1012</i>	<i>3.92</i>
4900	819	2.48	874	2.89	926	3.31	975	3.74	<i>1021</i>	<i>4.19</i>
5250	829	2.68	884	3.10	935	3.53	983	3.98	<i>1029</i>	<i>4.44</i>
5650	841	2.92	895	3.36	946	3.81	994	4.28	<i>1040</i>	<i>4.76</i>
6000	852	3.15	906	3.61	956	4.08	1003	4.56	—	—
6400	865	3.43	918	3.91	968	4.40	<i>1015</i>	<i>4.90</i>	—	—
6750	878	3.70	929	4.19	979	4.69	—	—	—	—
7150	892	4.03	943	4.53	—	—	—	—	—	—
7500	905	4.33	955	4.86	—	—	—	—	—	—

Standard static 514-680 rpm, 2.9 max BHP

Medium static 679-863 rpm, 3.7 max BHP

High static 826-1009 rpm, 4.9 max BHP

Boldface indicates alternate standard static drive package is required.
Italics indicate high static drive package with different motor pulley is required.

APPENDIX C — FAN DATA

Table G — 50TC-*20 Vertical Supply/Return (17.5 tons)

CFM	AVAILABLE EXTERNAL STATIC PRESSURE (in. wg)									
	0.2		0.4		0.6		0.8		1.0	
	RPM	BHP	RPM	BHP	RPM	BHP	RPM	BHP	RPM	BHP
5250	479	0.85	561	1.16	638	1.51	708	1.88	771	2.27
5700	506	1.03	582	1.35	656	1.72	723	2.11	785	2.53
6150	535	1.25	605	1.58	675	1.96	740	2.37	801	2.81
6550	561	1.46	627	1.81	693	2.20	756	2.63	815	3.08
7000	591	1.74	652	2.10	714	2.50	775	2.94	832	3.41
7450	622	2.05	679	2.42	737	2.84	795	3.30	850	3.78
7900	653	2.40	706	2.78	761	3.21	816	3.68	869	4.18
8300	681	2.75	731	3.14	783	3.58	836	4.06	887	4.57
8750	713	3.18	760	3.58	809	4.03	859	4.53	908	5.05

CFM	AVAILABLE EXTERNAL STATIC PRESSURE (in. wg)									
	1.2		1.4		1.6		1.8		2.0	
	RPM	BHP	RPM	BHP	RPM	BHP	RPM	BHP	RPM	BHP
5250	829	2.68	884	3.10	935	3.53	983	3.98	1029	4.44
5700	843	2.95	897	3.40	947	3.85	995	4.32	1041	4.80
6150	857	3.26	910	3.72	960	4.19	1008	4.68	1053	5.18
6550	871	3.54	923	4.03	972	4.52	1019	5.03	1064	5.55
7000	886	3.90	938	4.40	987	4.92	1033	5.45	1077	5.98
7450	903	4.29	953	4.81	1001	5.34	1047	5.89	1091	6.45
7900	921	4.71	970	5.25	1017	5.81	1062	6.38	1105	6.96
8300	937	5.11	985	5.67	1031	6.25	<u>1076</u>	<u>6.83</u>	1119	7.43
8750	956	5.61	1003	6.19	<u>1048</u>	<u>6.78</u>	1092	7.39	1134	8.01

Standard static 622-822 rpm, 3.7 max BHP

Medium static 713-879 rpm
Voltage: 208v / 230v / 460v / 575v
Max BHP: 6.5 / 6.9 / 7.0 / 8.3

High static 882-1078 rpm
Voltage: 208v / 230v / 460v / 575v
Max BHP: 6.5 / 6.9 / 7.0 / 8.3

High static drive with different motor pulley. Confirm max BHP coverage based on unit voltage selected.

Boldface indicates alternate standard static drive package is required.
Italics indicate high static drive package with different motor pulley is required (all voltages).

Underscore indicates operation point is covered by factory package. Confirm max BHP coverage based on unit voltage selected.

APPENDIX C — FAN DATA

Table H — 50TC-*24 Vertical Supply/Return (20 tons)

CFM	AVAILABLE EXTERNAL STATIC PRESSURE (in. wg)									
	0.2		0.4		0.6		0.8		1.0	
	RPM	BHP	RPM	BHP	RPM	BHP	RPM	BHP	RPM	BHP
6000	519	1.13	609	1.48	682	1.80	747	2.13	806	2.46
6500	545	1.36	633	1.75	705	2.11	768	2.46	826	2.82
7000	571	1.63	658	2.06	728	2.45	791	2.83	847	3.21
7500	597	1.93	683	2.40	753	2.83	814	3.24	869	3.65
8000	624	2.27	709	2.78	777	3.25	837	3.69	892	4.13
8500	650	2.64	734	3.20	802	3.71	861	4.19	915	4.66
9000	677	3.05	760	3.67	827	4.21	886	4.73	939	5.23
9500	703	3.50	786	4.17	853	4.76	910	5.31	963	5.85
10000	730	3.99	813	4.73	878	5.36	935	5.95	987	6.52

CFM	AVAILABLE EXTERNAL STATIC PRESSURE (in. wg)									
	1.2		1.4		1.6		1.8		2.0	
	RPM	BHP	RPM	BHP	RPM	BHP	RPM	BHP	RPM	BHP
6000	861	2.80	912	3.15	962	3.50	1008	3.86	1053	4.23
6500	880	3.18	930	3.55	978	3.92	1024	4.30	1068	4.69
7000	900	3.60	949	3.99	996	4.38	1041	4.78	1085	5.19
7500	921	4.06	969	4.47	1016	4.89	1060	5.31	1102	5.74
8000	943	4.57	990	5.00	1036	5.44	1079	5.89	1121	6.34
8500	965	5.12	1012	5.58	1056	6.05	1099	6.52	1140	6.99
9000	988	5.72	1034	6.21	1078	6.70	1120	7.19	1160	7.69
9500	1011	6.37	1057	6.89	1100	7.41	1141	7.93	<i>1181</i>	<i>8.45</i>
10000	1035	7.07	1080	7.62	1123	8.17	1163	8.72	—	—

Standard static 690-863 rpm, 4.9 max BHP

Medium static 835-1021 rpm
Voltage: 208v / 230v / 460v / 575v
Max BHP: 6.5 / 6.9 / 7.0 / 8.3

High static 941-1176 rpm
Voltage: 208v / 230v / 460v / 575v
Max BHP: 10.5 / 11.9 / 11.9 / 11.0

Boldface indicates alternate standard static drive package is required.
Italics indicate high static drive package with different motor pulley is required.

APPENDIX C — FAN DATA

Table I — 50TC-*28 Vertical Supply/Return (25 tons)

CFM	AVAILABLE EXTERNAL STATIC PRESSURE (in. wg)									
	0.2		0.4		0.6		0.8		1.0	
	RPM	BHP	RPM	BHP	RPM	BHP	RPM	BHP	RPM	BHP
7500	555	1.35	664	1.85	744	2.29	812	2.70	872	3.12
8150	579	1.62	690	2.19	771	2.68	838	3.14	898	3.60
8750	599	1.89	714	2.54	795	3.08	863	3.59	923	4.08
9400	619	2.20	739	2.96	822	3.56	889	4.12	949	4.65
10000	635	2.50	762	3.38	846	4.04	914	4.65	974	5.23
10650	649	2.82	787	3.86	872	4.61	940	5.28	1000	5.91
11250	653	3.09	808	4.35	895	5.17	965	5.90	<u>1025</u>	<u>6.58</u>
11900	647	3.31	831	4.91	921	5.83	<u>991</u>	<u>6.63</u>	<u>1051</u>	<u>7.37</u>
12500	641	3.51	851	5.46	943	6.48	<u>1015</u>	<u>7.34</u>	<u>1075</u>	<u>8.14</u>

CFM	AVAILABLE EXTERNAL STATIC PRESSURE (in. wg)									
	1.2		1.4		1.6		1.8		2.0	
	RPM	BHP	RPM	BHP	RPM	BHP	RPM	BHP	RPM	BHP
7500	927	3.53	978	3.94	1026	4.36	1071	4.79	1114	5.21
8150	953	4.04	1003	4.49	1051	4.94	1096	5.39	1138	5.85
8750	977	4.56	1027	5.04	1074	5.53	1119	6.01	1161	6.49
9400	1003	5.18	1053	5.70	1100	6.21	1144	6.73	1186	7.25
10000	1028	5.80	1077	6.35	1124	6.90	1168	7.45	—	—
10650	<u>1054</u>	<u>6.52</u>	<u>1104</u>	<u>7.12</u>	1150	7.71	—	—	—	—
11250	<u>1079</u>	<u>7.24</u>	<u>1128</u>	<u>7.88</u>	1174	8.51	—	—	—	—
11900	<u>1105</u>	<u>8.07</u>	<u>1155</u>	<u>8.76</u>	—	—	—	—	—	—
12500	1130	8.90	1179	9.63	—	—	—	—	—	—

Standard static 717-911 rpm, 4.9 max BHP

Medium static 913-1116 rpm
Voltage: 208v / 230v / 460v / 575v
Max BHP: 6.5 / 6.9 / 7.0 / 8.3

High static 941-1176 rpm
Voltage: 208v / 230v / 460v / 575v
Max BHP: 10.5 / 11.9 / 11.9 / 11.0

Boldface indicates alternate standard static drive package is required.
Italics indicate high static drive package with different motor pulley is required.

Underscore indicates operation point is covered by medium static drive.
Confirm max BHP coverage based on unit voltage selected.

APPENDIX C — FAN DATA

Table J — 50TC-*30 Vertical Supply/Return (27.5 tons)

CFM	AVAILABLE EXTERNAL STATIC PRESSURE (in. wg)									
	0.2		0.4		0.6		0.8		1.0	
	RPM	BHP	RPM	BHP	RPM	BHP	RPM	BHP	RPM	BHP
8250	582	1.66	694	2.25	775	2.75	842	3.22	902	3.67
8950	605	1.98	722	2.67	803	3.23	871	3.75	931	4.25
9650	626	2.32	749	3.13	832	3.76	900	4.34	959	4.89
10300	642	2.65	774	3.60	858	4.30	926	4.93	986	5.54
11000	653	2.99	800	4.14	886	4.93	955	5.64	1014	6.29
11700	647	3.22	824	4.73	913	5.62	983	6.40	1043	7.12
12400	641	3.47	848	5.36	940	6.37	1011	7.22	1071	8.01
13050	635	3.70	868	5.98	964	7.11	1036	8.04	1097	8.90
13750	629	3.96	888	6.67	989	7.95	1063	8.99	1125	9.92

CFM	AVAILABLE EXTERNAL STATIC PRESSURE (in. wg)									
	1.2		1.4		1.6		1.8		2.0	
	RPM	BHP	RPM	BHP	RPM	BHP	RPM	BHP	RPM	BHP
8250	957	4.13	1007	4.58	1055	5.04	1099	5.49	1142	5.95
8950	985	4.75	1035	5.24	1082	5.73	1126	6.22	1169	6.72
9650	1013	5.43	1063	5.96	1110	6.49	1154	7.02	1196	7.56
10300	1040	6.12	1089	6.70	1136	7.27	1180	7.83	1221	8.40
11000	1068	6.93	1118	7.55	1164	8.17	1208	8.77	1249	9.38
11700	1097	7.81	1147	8.48	1193	9.14	1236	9.79	1277	10.44
12400	1126	8.76	1175	9.48	1221	10.19	1265	10.89	—	—
13050	1152	9.71	1202	10.48	1248	11.24	1291	11.99	—	—
13750	1180	10.79	1230	11.63	1277	12.45	—	—	—	—

Standard static 751-954 rpm
Voltage: 208v / 230v / 460v / 575v
Max BHP: 6.5 / 6.9 / 7.0 / 8.3

Medium static 973-1175 rpm
Voltage: 208v / 230v / 460v / 575v
Max BHP: 10.5 / 11.9 / 11.9 / 11.0

High static 1015-1300 rpm
Voltage: 208v / 230v / 460v / 575v
Max BHP: 11.9 / 12.9 / 12.9 / 14.1

Operation point is covered by high static drive. Confirm max BHP coverage based on unit voltage selected.

Boldface indicates alternate standard static drive package is required.

APPENDIX C — FAN DATA

Table K — 50TC-*18 Horizontal Supply/Return (15 tons)

CFM	AVAILABLE EXTERNAL STATIC PRESSURE (in. wg)									
	0.2		0.4		0.6		0.8		1.0	
	RPM	BHP	RPM	BHP	RPM	BHP	RPM	BHP	RPM	BHP
4500	472	1.04	549	1.51	616	2.03	676	2.59	731	3.19
4900	500	1.26	573	1.76	638	2.30	696	2.89	750	3.51
5250	525	1.48	595	2.00	658	2.57	715	3.18	767	3.82
5650	554	1.76	620	2.30	681	2.90	736	3.54	787	4.21
6000	580	2.04	643	2.61	702	3.22	756	3.88	806	4.58
6400	610	2.39	670	2.99	727	3.64	779	4.32	—	—
6750	636	2.74	695	3.36	749	4.03	800	4.74	—	—
7150	667	3.18	723	3.83	775	4.52	—	—	—	—
7500	694	3.60	748	4.28	—	—	—	—	—	—

CFM	AVAILABLE EXTERNAL STATIC PRESSURE (in. wg)									
	1.2		1.4		1.6		1.8		2.0	
	RPM	BHP	RPM	BHP	RPM	BHP	RPM	BHP	RPM	BHP
4500	781	3.81	828	4.46	—	—	—	—	—	—
4900	799	4.16	845	4.84	—	—	—	—	—	—
5250	816	4.49	—	—	—	—	—	—	—	—
5650	—	—	—	—	—	—	—	—	—	—
6000	—	—	—	—	—	—	—	—	—	—
6400	—	—	—	—	—	—	—	—	—	—
6750	—	—	—	—	—	—	—	—	—	—
7150	—	—	—	—	—	—	—	—	—	—
7500	—	—	—	—	—	—	—	—	—	—

Standard static 514-680 rpm, 2.9 max BHP
 Medium static 614-780 rpm, 3.7 max BHP
 High static 746-912 rpm, 4.9 max BHP



APPENDIX C — FAN DATA

Table L — 50TC-*21 Horizontal Supply/Return (17.5 tons)

CFM	AVAILABLE EXTERNAL STATIC PRESSURE (in. wg)									
	0.2		0.4		0.6		0.8		1.0	
	RPM	BHP	RPM	BHP	RPM	BHP	RPM	BHP	RPM	BHP
5250	525	1.48	595	2.00	658	2.57	715	3.18	767	3.82
5700	558	1.80	624	2.35	684	2.95	739	3.58	790	4.26
6150	591	2.16	654	2.74	711	3.37	764	4.04	814	4.75
6550	621	2.54	681	3.14	736	3.80	788	4.50	836	5.23
7000	656	3.01	712	3.65	765	4.33	<i>815</i>	<i>5.06</i>	862	5.82
7450	690	3.54	744	4.21	795	4.93	843	5.68	888	6.47
7900	726	4.14	777	4.84	825	5.59	872	6.37	916	7.19
8300	757	4.72	<i>806</i>	<i>5.45</i>	853	6.23	898	7.04	940	7.89
8750	793	5.45	840	6.21	885	7.02	928	7.86	—	—

CFM	AVAILABLE EXTERNAL STATIC PRESSURE (in. wg)									
	1.2		1.4		1.6		1.8		2.0	
	RPM	BHP	RPM	BHP	RPM	BHP	RPM	BHP	RPM	BHP
5250	816	4.49	861	5.20	904	5.92	945	6.68	984	7.45
5700	838	4.96	882	5.70	925	6.46	965	7.24	1003	8.04
6150	861	5.48	904	6.25	946	7.04	986	7.85	—	—
6550	882	5.99	925	6.78	966	7.60	—	—	—	—
7000	906	6.61	948	7.43	988	8.28	—	—	—	—
7450	931	7.30	973	8.15	—	—	—	—	—	—
7900	958	8.05	—	—	—	—	—	—	—	—
8300	—	—	—	—	—	—	—	—	—	—
8750	—	—	—	—	—	—	—	—	—	—

Standard static 622-822 rpm, 3.7 max BHP

Medium static 713-879 rpm, 4.9 max BHP

High static 835-1021 rpm

Voltage: 208v / 230v / 460v / 575v

Max BHP: 6.5 / 6.9 / 7.0 / 8.3

Operation point is covered by high static drive. Confirm max BHP coverage based on unit voltage selected.

Italics indicate high static drive package with different motor pulley is required.

APPENDIX C — FAN DATA

Table M — 50TC-*25 Horizontal Supply/Return (20 tons)

CFM	AVAILABLE EXTERNAL STATIC PRESSURE (in. wg)									
	0.2		0.4		0.6		0.8		1.0	
	RPM	BHP	RPM	BHP	RPM	BHP	RPM	BHP	RPM	BHP
6000	575	1.54	645	2.01	708	2.51	764	3.02	815	3.56
6500	610	1.87	677	2.37	738	2.90	792	3.45	842	4.02
7000	646	2.25	710	2.79	768	3.35	821	3.93	870	4.53
7500	683	2.68	744	3.25	800	3.85	851	4.46	899	5.09
8000	720	3.17	779	3.78	832	4.41	882	5.05	929	5.72
8500	758	3.73	814	4.36	865	5.02	913	5.70	959	6.40
9000	796	4.34	849	5.01	899	5.71	946	6.42	<u>990</u>	<u>7.15</u>
9500	834	5.03	885	5.73	933	6.46	978	7.20	<u>1021</u>	<u>7.96</u>
10000	873	5.78	921	6.52	968	7.28	1011	8.06	1053	8.86

CFM	AVAILABLE EXTERNAL STATIC PRESSURE (in. wg)									
	1.2		1.4		1.6		1.8		2.0	
	RPM	BHP	RPM	BHP	RPM	BHP	RPM	BHP	RPM	BHP
6000	863	4.11	907	4.68	949	5.26	989	5.86	1026	6.47
6500	889	4.60	933	5.20	974	5.82	1013	6.44	1051	7.09
7000	916	5.14	959	5.77	1000	6.42	1039	7.08	1076	7.75
7500	944	5.74	986	6.40	1026	7.08	1064	7.77	—	—
8000	972	6.39	<u>1014</u>	<u>7.09</u>	1053	7.79	1091	8.51	—	—
8500	<u>1002</u>	<u>7.11</u>	1042	7.83	1081	8.57	—	—	—	—
9000	1031	7.89	1071	8.65	—	—	—	—	—	—
9500	1062	8.74	—	—	—	—	—	—	—	—
10000	1093	9.66	—	—	—	—	—	—	—	—

Standard static 690-863 rpm, 4.9 max BHP

Medium static 835-1021 rpm
Voltage: 208v / 230v / 460v / 575v
Max BHP: 6.5 / 6.9 / 7.0 / 8.3

High static 941-1100 rpm
Voltage: 208v / 230v / 460v / 575v
Max BHP: 10.5 / 11.9 / 11.9 / 11.0

Boldface indicates alternate standard static drive package is required.
Underscore indicates operation point is covered by medium static drive.
Confirm max BHP coverage based on unit voltage selected.

APPENDIX C — FAN DATA

Table N — 50TC-*29 Horizontal Supply/Return (25 tons)

CFM	AVAILABLE EXTERNAL STATIC PRESSURE (in. wg)									
	0.2		0.4		0.6		0.8		1.0	
	RPM	BHP	RPM	BHP	RPM	BHP	RPM	BHP	RPM	BHP
7500	683	2.68	744	3.25	800	3.85	851	4.46	899	5.09
8000	720	3.17	779	3.78	832	4.41	882	5.05	929	5.72
8500	758	3.73	814	4.36	865	5.02	913	5.70	959	6.40
9000	796	4.34	849	5.01	899	5.71	946	6.42	990	7.15
9500	834	5.03	885	5.73	933	6.46	978	7.20	1021	7.96
10000	873	5.78	921	6.52	968	7.28	1011	8.06	1053	8.86
10500	911	6.62	958	7.39	1003	8.18	1045	8.99	1086	9.82
11000	950	7.53	995	8.34	1038	9.16	1079	10.01	—	—
11500	989	8.53	1033	9.37	1074	10.23	—	—	—	—

CFM	AVAILABLE EXTERNAL STATIC PRESSURE (in. wg)									
	1.2		1.4		1.6		1.8		2.0	
	RPM	BHP	RPM	BHP	RPM	BHP	RPM	BHP	RPM	BHP
7500	944	5.74	986	6.40	1026	7.08	1064	7.77	—	—
8000	972	6.39	1014	7.09	1053	7.79	1091	8.51	—	—
8500	1002	7.11	1042	7.83	1081	8.57	—	—	—	—
9000	1031	7.89	1071	8.65	—	—	—	—	—	—
9500	1062	8.74	—	—	—	—	—	—	—	—
10000	1093	9.66	—	—	—	—	—	—	—	—
10500	—	—	—	—	—	—	—	—	—	—
11000	—	—	—	—	—	—	—	—	—	—
11500	—	—	—	—	—	—	—	—	—	—

Standard static 647-791 rpm, 4.9 max BHP

Medium static 755-923 rpm

Voltage: 208v / 230v / 460v / 575v

Max BHP: 6.5 / 6.9 / 7.0 / 8.3

High static 906-1100 rpm

Voltage: 208v / 230v / 460v / 575v

Max BHP: 10.5 / 11.9 / 11.9 / 11.0

APPENDIX C — FAN DATA

Table O — Pulley Adjustment (Vertical Units)

UNIT		MOTOR/DRIVE COMBO	MOTOR PULLEY TURNS OPEN										
			0	0.5	1	1.5	2	2.5	3	3.5	4	4.5	5
17	3 phase	Standard Static	680	663	647	630	614	597	580	564	547	531	514
		Medium Static	863	845	826	808	789	771	753	734	716	697	679
		High Static	1009	991	972	954	936	918	899	881	863	844	826
20	3 phase	Standard Static	822	802	782	762	742	722	702	682	662	642	622
		Medium Static	879	862	846	829	813	796	779	763	746	730	713
		High Static	1078	1058	1039	1019	1000	980	960	941	921	902	882
24	3 phase	Standard Static	863	846	828	811	794	777	759	742	725	707	690
		Medium Static	1021	1002	984	965	947	928	909	891	872	854	835
		High Static	1176	1153	1129	1106	1082	1059	1035	1012	988	965	941
28	3 phase	Standard Static	911	892	872	853	833	814	795	775	756	736	717
		Medium Static	1116	1096	1075	1055	1035	1015	994	974	954	933	913
		High Static	1176	1153	1129	1106	1082	1059	1035	1012	988	965	941
30	3 phase	Standard Static	954	934	913	893	873	853	832	812	792	771	751
		Medium Static	1175	1155	1135	1114	1094	1074	1054	1034	1013	993	973
		High Static	1299	1271	1242	1214	1185	1157	1129	1100	1072	1043	1015

Factory setting

Table P — Pulley Adjustment (Horizontal Units)

UNIT		MOTOR/DRIVE COMBO	MOTOR PULLEY TURNS OPEN										
			0	0.5	1	1.5	2	2.5	3	3.5	4	4.5	5
18	3 phase	Standard Static	680	663	647	630	614	597	580	564	547	531	514
		Medium Static	780	763	747	730	714	697	680	664	647	631	614
		High Static	912	895	879	862	846	829	812	796	779	763	746
21	3 phase	Standard Static	822	802	782	762	742	722	702	682	662	642	622
		Medium Static	879	862	846	829	813	796	779	763	746	730	713
		High Static	1021	1002	984	965	947	928	909	891	872	854	835
25	3 phase	Standard Static	863	846	828	811	794	777	759	742	725	707	690
		Medium Static	1021	1002	984	965	947	928	909	891	872	854	835
		High Static	1176	1153	1129	1106	1082	1059	1035	1012	988	965	941
29	3 phase	Standard Static	791	777	762	748	733	719	705	690	676	661	647
		Medium Static	923	906	889	873	856	839	822	805	789	772	755
		High Static	1107	1087	1067	1047	1027	1007	986	966	946	926	906

Factory setting

APPENDIX D — WIRING DIAGRAMS

Table Q — Wiring Diagrams

50TC SIZE	VOLTAGE	DUAL CIRCUIT		HUMIDI-MIZER	
		CONTROL	POWER	CONTROL	POWER
17, 18	208/230-3-60	50HE500887 - L (page 80)	50HE500894 - L (page 83)	50HE502180 - G (page 85)	50HE502185 - E (page 86)
	460-3-60		50HE500895 - L (page 84)		50HE502182 - F (page 87)
	575-3-60				50HE501774 - F (page 88)
20, 21	208/230-3-60	50HE500887 - L (page 80)	50HE500894 - L (page 83)	50HE502180 - G (page 85)	50HE502185 - E (page 86)
	460-3-60		50HE500895 - L (page 84)		50HE502182 - F (page 87)
	575-3-60				50HE501774 - F (page 88)
24, 25	208/230-3-60	50HE500887 - L (page 80)	50HE500894 - L (page 83)	50HE502180 - G (page v)	50HE502185 - E (page 86)
	460-3-60		50HE500895 - L (page 84)		50HE502182 - F (page 87)
	575-3-60				50HE501774 - F (page 88)
28, 29	208/230-3-60	50HE500887 - L (page 80)	50HE500894 - L (page 83)	50HE502180 - G (page 85)	50HE502185 - E (page 86)
	460-3-60		50HE500895 - L (page 84)		50HE502182 - F (page 87)
	575-3-60				50HE501774 - F (page 88)
30	208/230-3-60	50HE502337 - E (page 81)	50HE500894 - L (page 83)	50HE502180 - G (page 85)	50HE502185 - E (page 86)
	460-3-60	50HE502335 - E (page 82)	50HE500895 - L (page 84)		50HE502182 - F (page 87)
	575-3-60	50HE502335 - E (page 82)			50HE501774 - F (page 88)
ALL	PremierLink*		50HE500891 - F (page 89)		
ALL	RTU-Open*		50HE501687 - C (page 90)		
ALL	SAV / VFD*		50HE502975 - E (page 91)		

NOTE: Component arrangement on Control; Legend on Power Schematic.

* PremierLink, RTU-OPEN, and SAV/VFD control labels overlay a portion of the base unit control label. The base unit label drawing and the control option drawing are required to provide a complete unit control diagram.

APPENDIX D — WIRING DIAGRAMS

STD TIER PAC CONTROL 208/230V, 460V, 575V

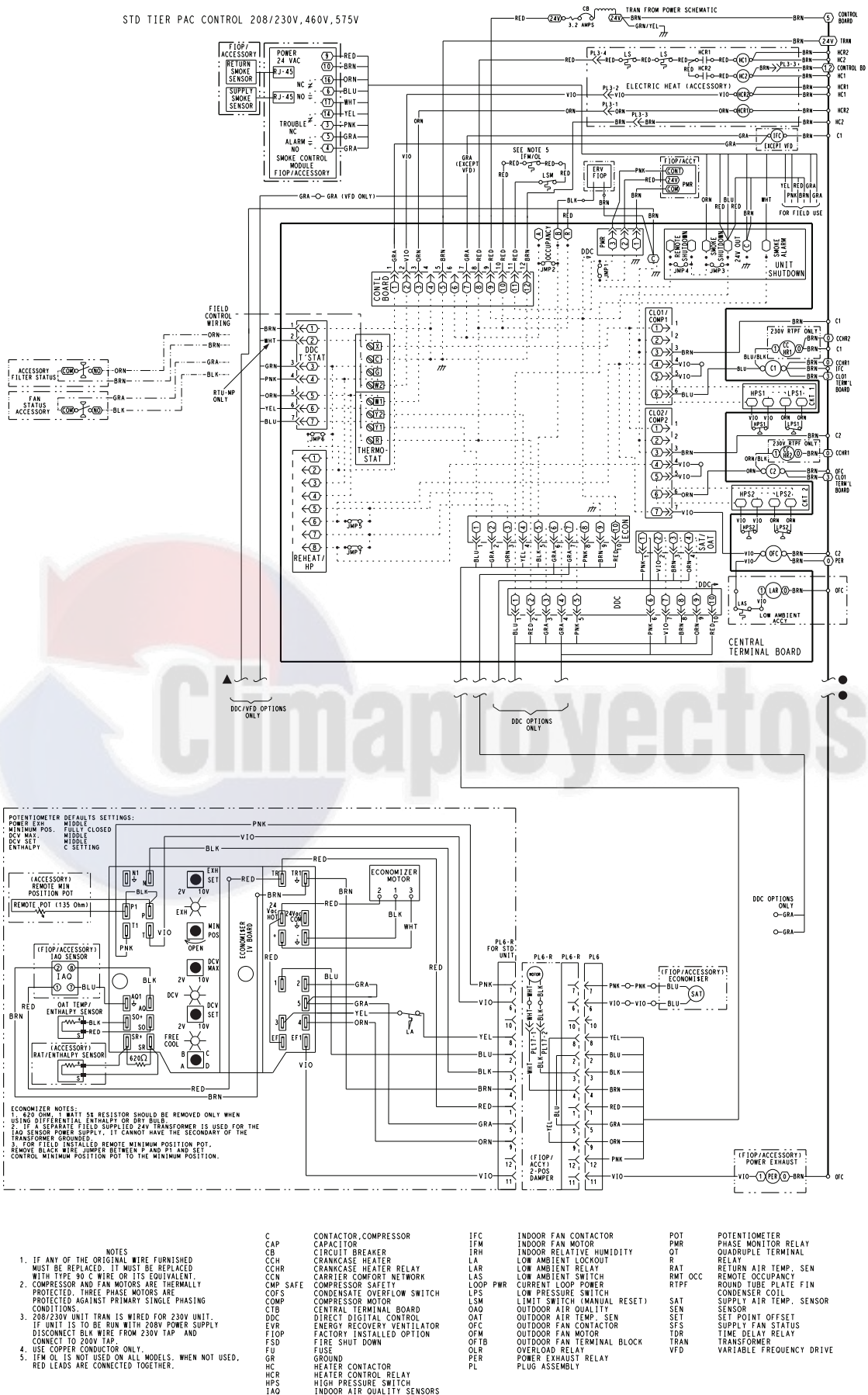

Fig. C — 50TC 17-28 Control Wiring Diagram

APPENDIX D — WIRING DIAGRAMS

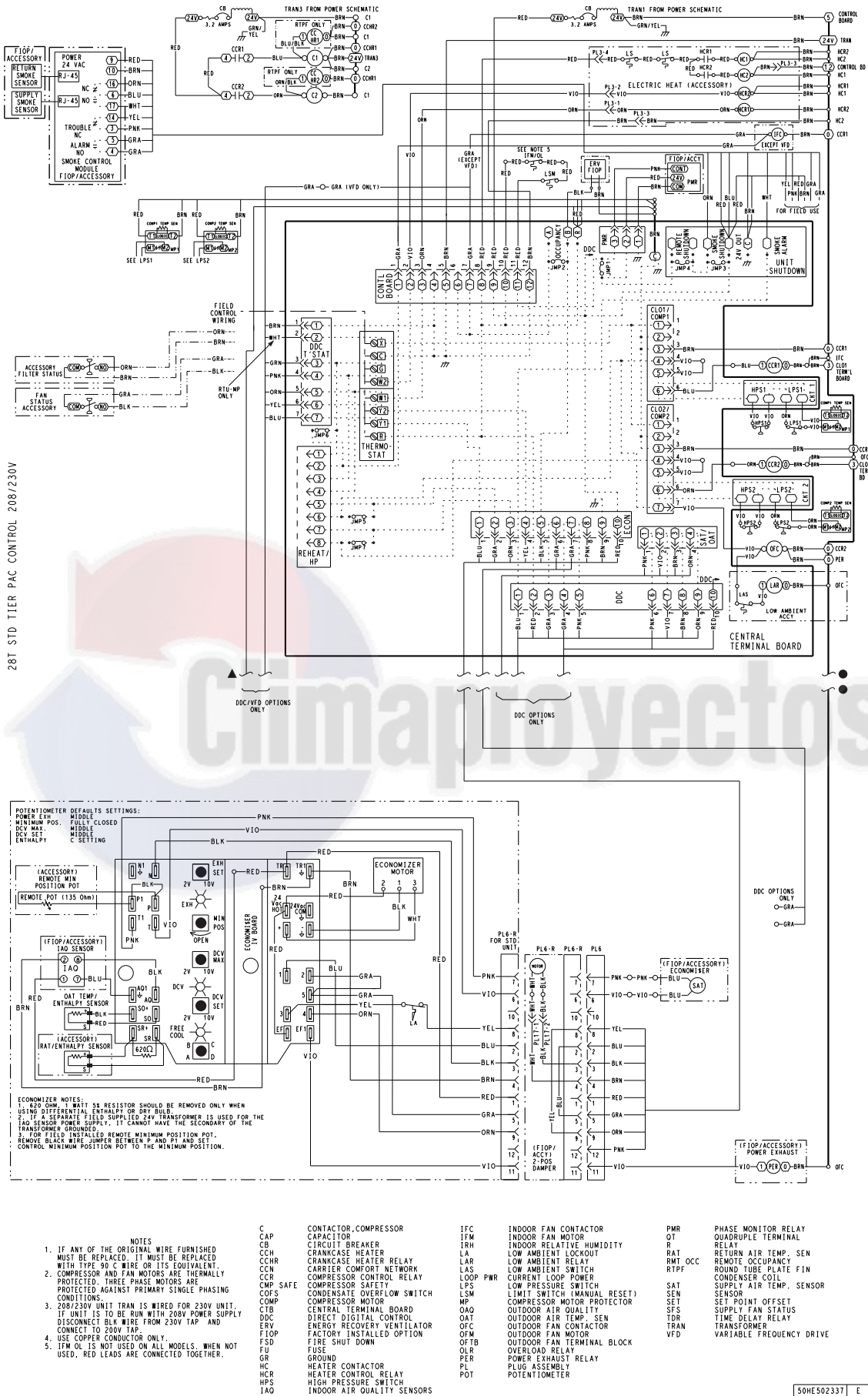
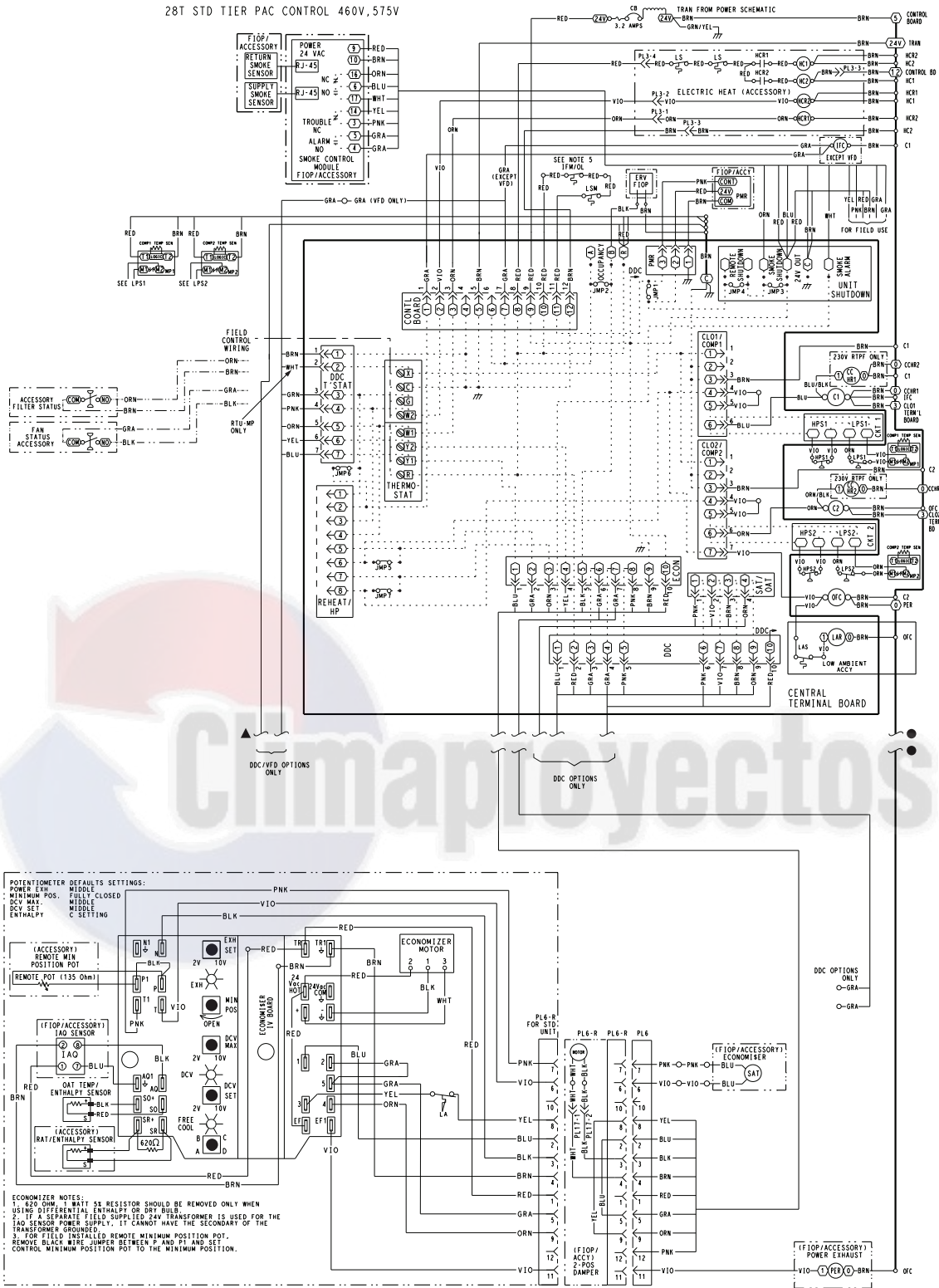

Fig. D — 50TC 30 Control Wiring Diagram (208/230-3-60 Units)

APPENDIX D — WIRING DIAGRAMS

28T STD TIER PAC CONTROL 460V, 575V



POTENTIOMETER DEFAULTS SETTINGS:
 POWER EVR MIDDLE
 MINIMUM POS. FULLY CLOSED
 DCV MAX. MIDDLE
 ENTHALPY C SETTING

ECONOMIZER NOTES:
 1. 620 OHM 1/2 WATT 5% RESISTOR SHOULD BE REMOVED ONLY WHEN USING DIFFERENTIAL ENTHALPY OR SHY BLUE.
 2. IF A SEPARATE FIELD SUPPLIED 24V TRANSFORMER IS USED FOR THE IAQ SENSOR POWER SUPPLY, IT CANNOT HAVE THE SECONDARY OF THE TRANSFORMER GROUNDING.
 3. FOR FIELD INSTALLED REMOTE MINIMUM POSITION POT, REMOVE BLACK WIRE JUMPER BETWEEN P AND P1 AND SET CONTROL MINIMUM POSITION POT TO THE MINIMUM POSITION.

- NOTES
1. IF ANY OF THE ORIGINAL WIRE FURNISHED MUST BE REPLACED, IT MUST BE REPLACED WITH TYP. 90 C WIRE OR ITS EQUIVALENT.
 2. COMPRESSOR AND FAN MOTORS ARE THERMALLY PROTECTED. THREE PHASE MOTORS ARE PROTECTED AGAINST PRIMARY SINGLE PHASING CONDITIONS.
 3. 208/230V UNIT TRAN IS WIRED FOR 230V UNIT. IF UNIT IS TO BE RUN WITH 208V POWER SUPPLY DISCONNECT BLK WIRE FROM 230V TAP AND CONNECT TO 200V TAP.
 4. USE COPPER CONDUCTOR ONLY.
 5. IFM OL IS NOT USED ON ALL MODELS. WHEN NOT USED, RED LEADS ARE CONNECTED TOGETHER.

C	CONTACTOR, COMPRESSOR	IFC	INDOOR FAN CONTACTOR	POT	POTENTIOMETER
CAP	CAPACITOR	IFM	INDOOR FAN MOTOR	PWR	PHASE MONITOR RELAY
CB	CIRCUIT BREAKER	IRH	INDOOR RELATIVE HUMIDITY	QT	QUADRUPLE TERMINAL
CCH	CRANKCASE HEATER	LA	LOW AMBIENT LOCKOUT	R	RELAY
CCHR	CRANKCASE HEATER RELAY	LAR	LOW AMBIENT RELAY	RAT	RETURN AIR TEMP. SEN
CCN	CARRIER COMFORT NETWORK	LAS	LOW AMBIENT SWITCH	RMT OCC	REMOTE OCCUPANCY
CSF SAFE	COMPRESSOR SAFETY	LOOP PWR	CURRENT LOOP POWER	RTPF	ROUND TUBE PLATE FIN
COFS	CONDENSATE OVERFLOW SWITCH	LPS	LOW PRESSURE SWITCH	SCC	CONDENSER COIL
COMP	COMPRESSOR MOTOR	LSM	LIMIT SWITCH (MANUAL RESET)	SAT	SUPPLY AIR TEMP. SENSOR
CTB	CENTRAL TERMINAL BOARD	MP	COMPRESSOR MOTOR PROTECTOR	SEN	SENSOR
DDC	DIRECT DIGITAL CONTROL	OAO	OUTDOOR AIR QUALITY	SET	SET POINT OFFSET
ERV	ENERGY RECOVERY VENTILATOR	OAT	OUTDOOR AIR TEMP. SEN	SFS	SUPPLY FAN STATUS
FTOP	FACTORY INSTALLED OPTION	OFC	OUTDOOR FAN CONTACTOR	TDR	TIME DELAY RELAY
FSD	FIRE SHUT DOWN	OFM	OUTDOOR FAN MOTOR	TRAN	TRANSFORMER
FU	FUSE	OFTB	OUTDOOR FAN TERMINAL BLOCK	VFD	VARIABLE FREQUENCY DRIVE
GR	GROUND	OLR	OVERLOAD RELAY		
HC	HEATER CONTACTOR	PER	POWER EXHAUST RELAY		
HCR	HEATER CONTROL RELAY	PL	PLUG ASSEMBLY		
HPS	HIGH PRESSURE SWITCH				
IAQ	INDOOR AIR QUALITY SENSORS				

50HE502335 E

Fig. E — 50TC 30 Control Wiring Diagram (460-3-60, 575-3-60 Units)

APPENDIX D — WIRING DIAGRAMS

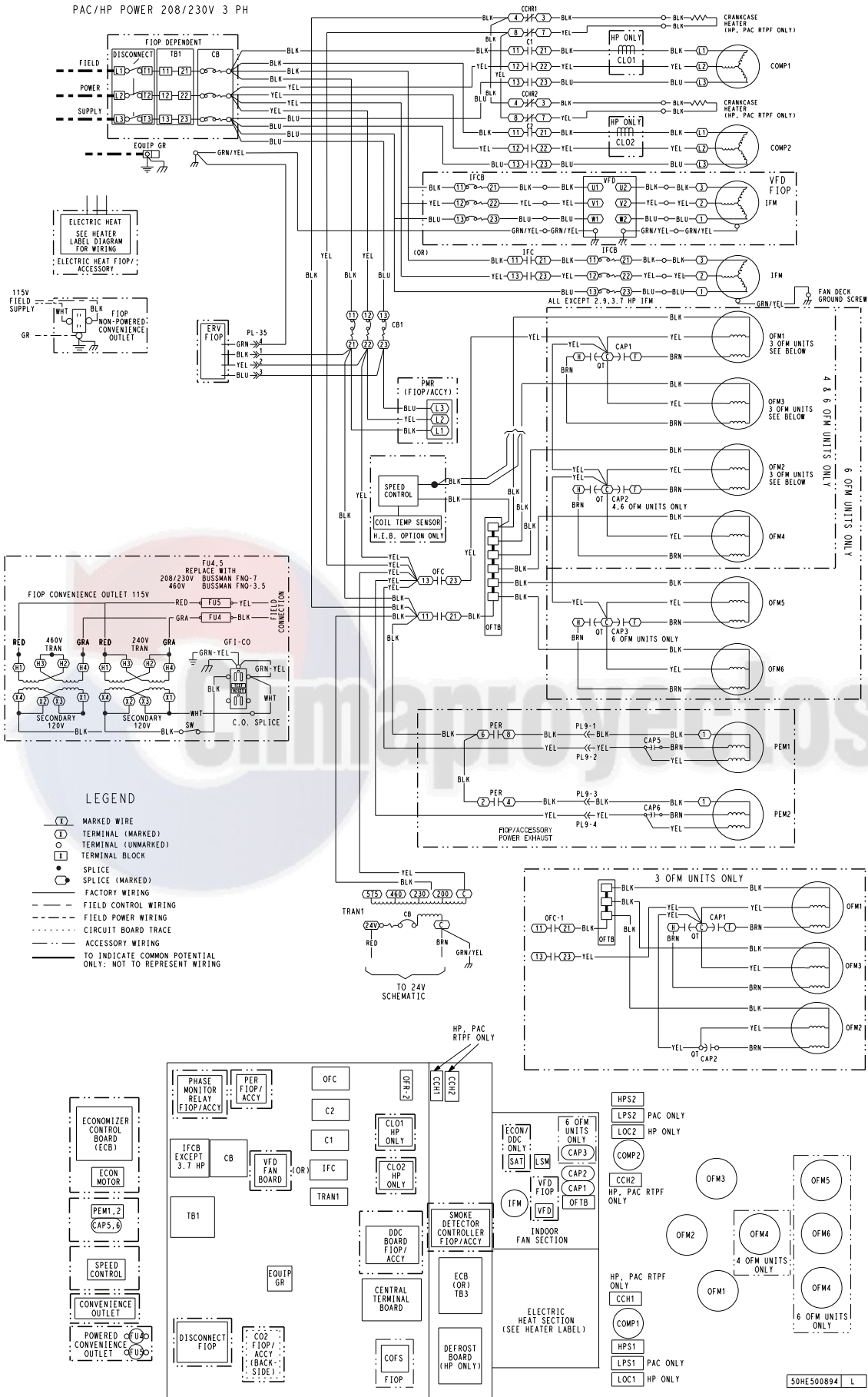

Fig. F — 50TC 17-30 Power Wiring Diagram (208/230-3-60 Units)

APPENDIX D — WIRING DIAGRAMS

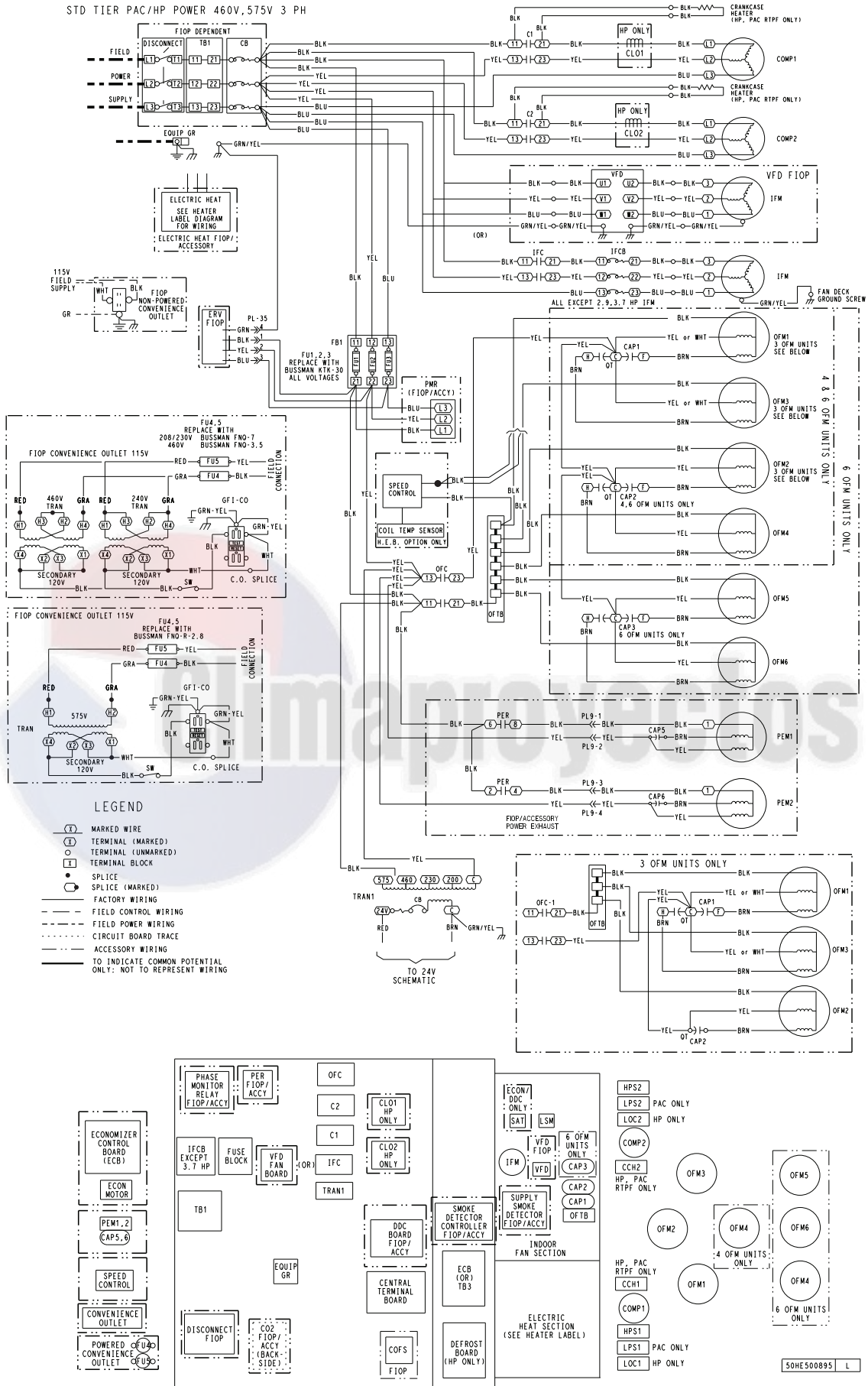

Fig. G — 50TC 17-30 Power Wiring Diagram (460-3-60, 575-3-60 Units)

APPENDIX D — WIRING DIAGRAMS

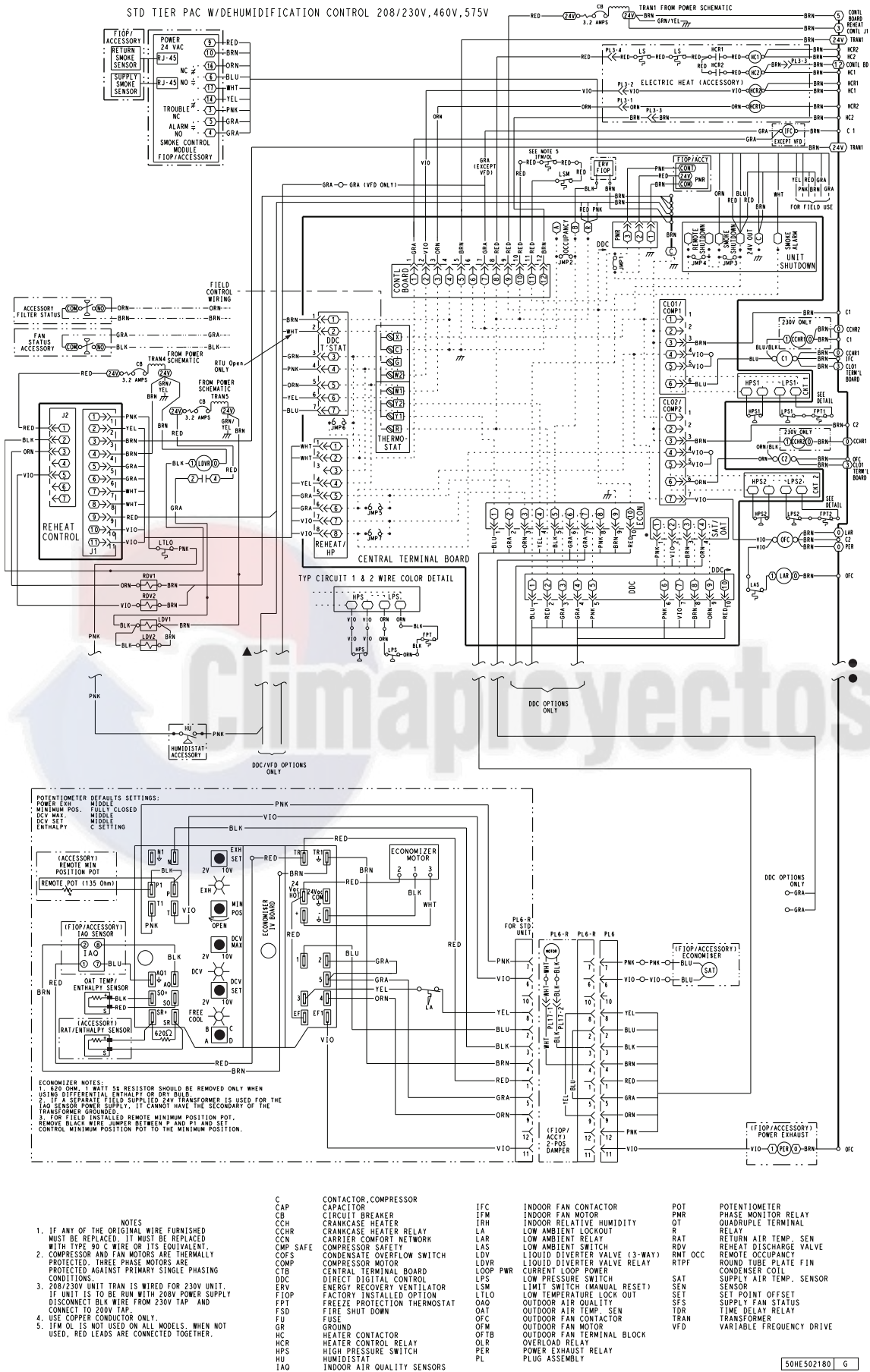
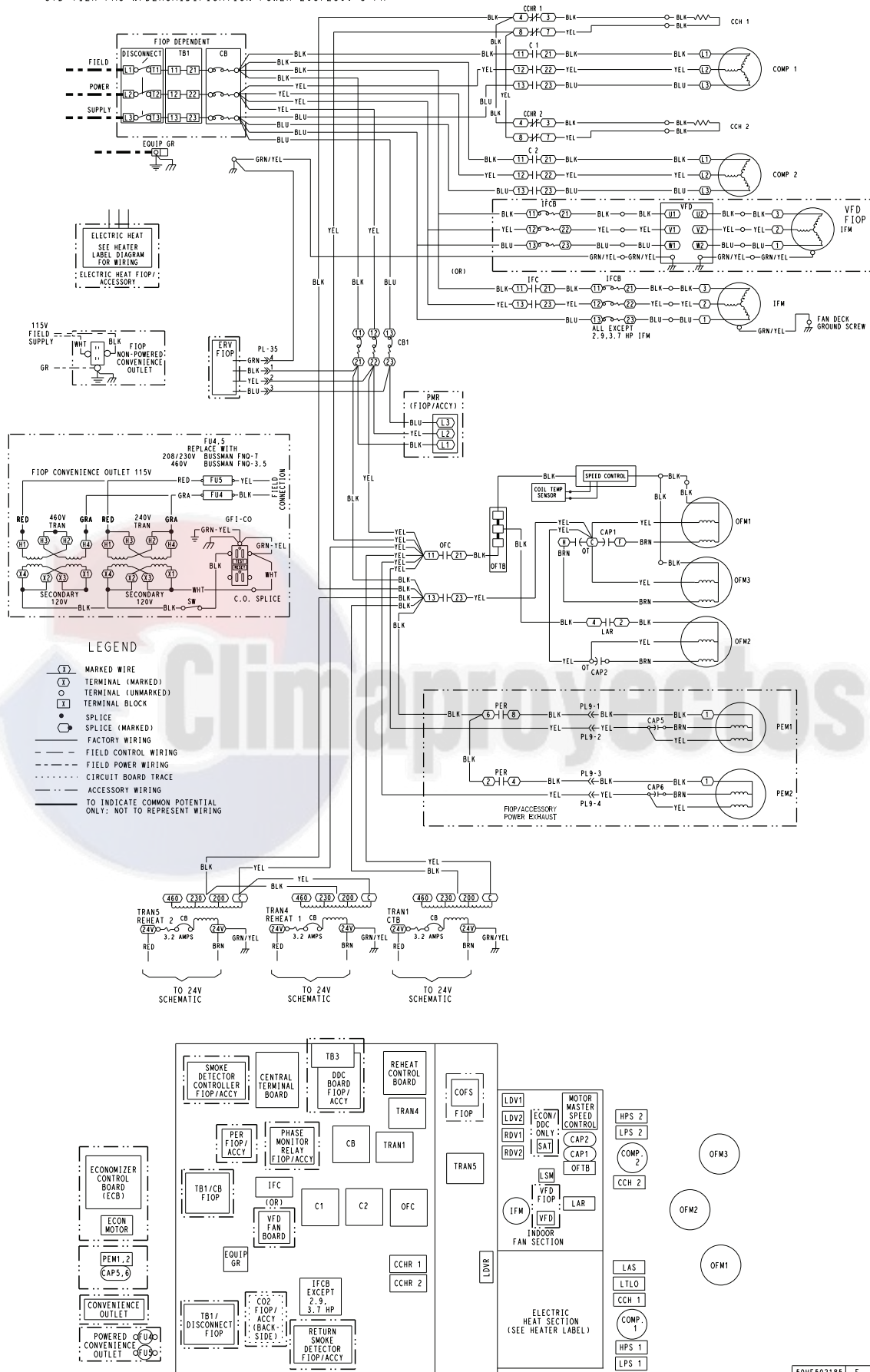

Fig. H — 50TC 17-30 Control Wiring Diagram with Humidi-MiZer System

APPENDIX D — WIRING DIAGRAMS

STD TIER PAC W/DEHUMIDIFICATION POWER 208/230V 3 PH



APPENDIX D — WIRING DIAGRAMS

STD TIER PAC W/DEHUMIDIFICATION POWER 460V 3 PH

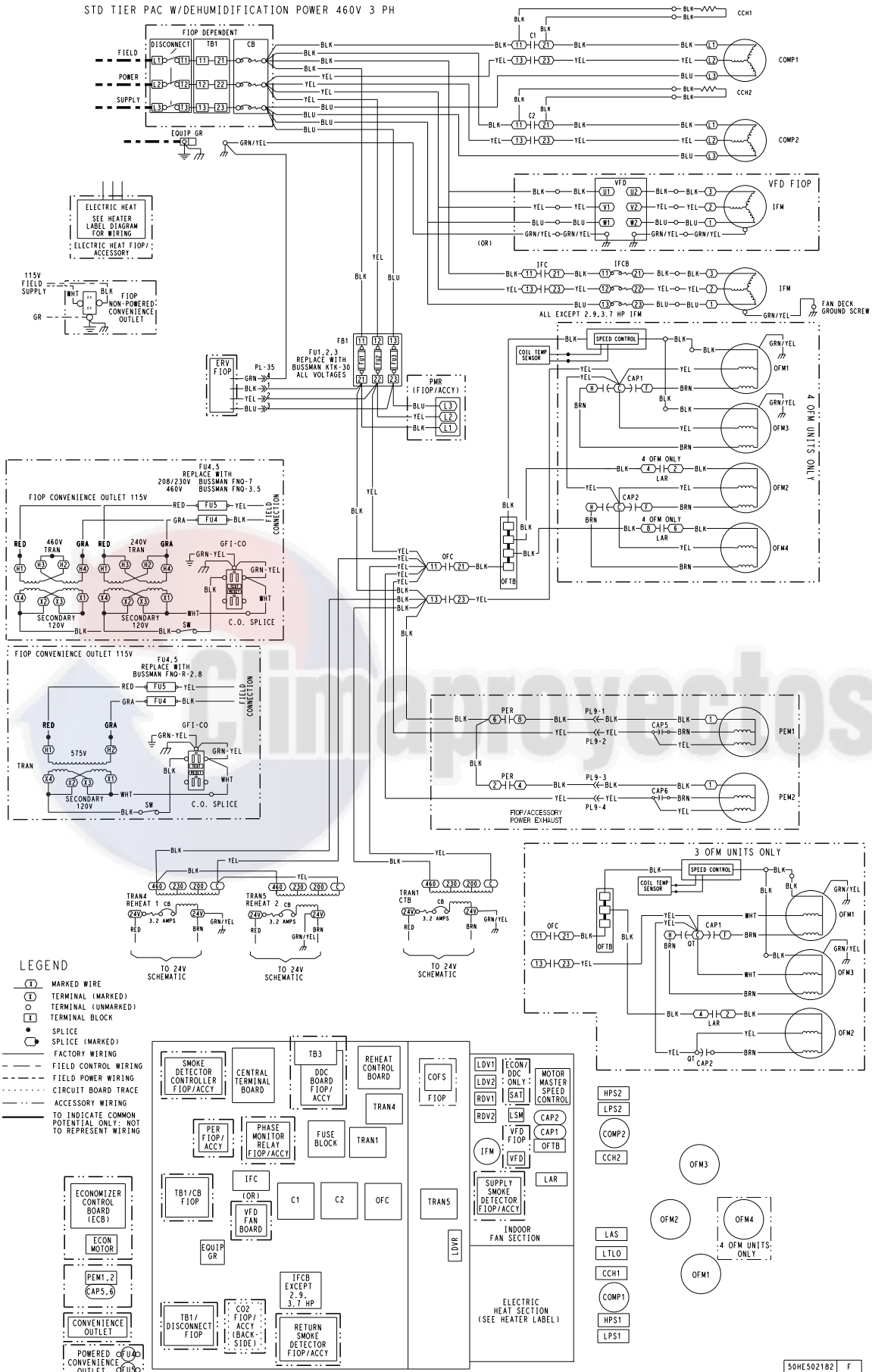

Fig. J — 50TC 17-30 Power Wiring Diagram (460-3-60 Units) with Humidi-MiZer System

APPENDIX D — WIRING DIAGRAMS

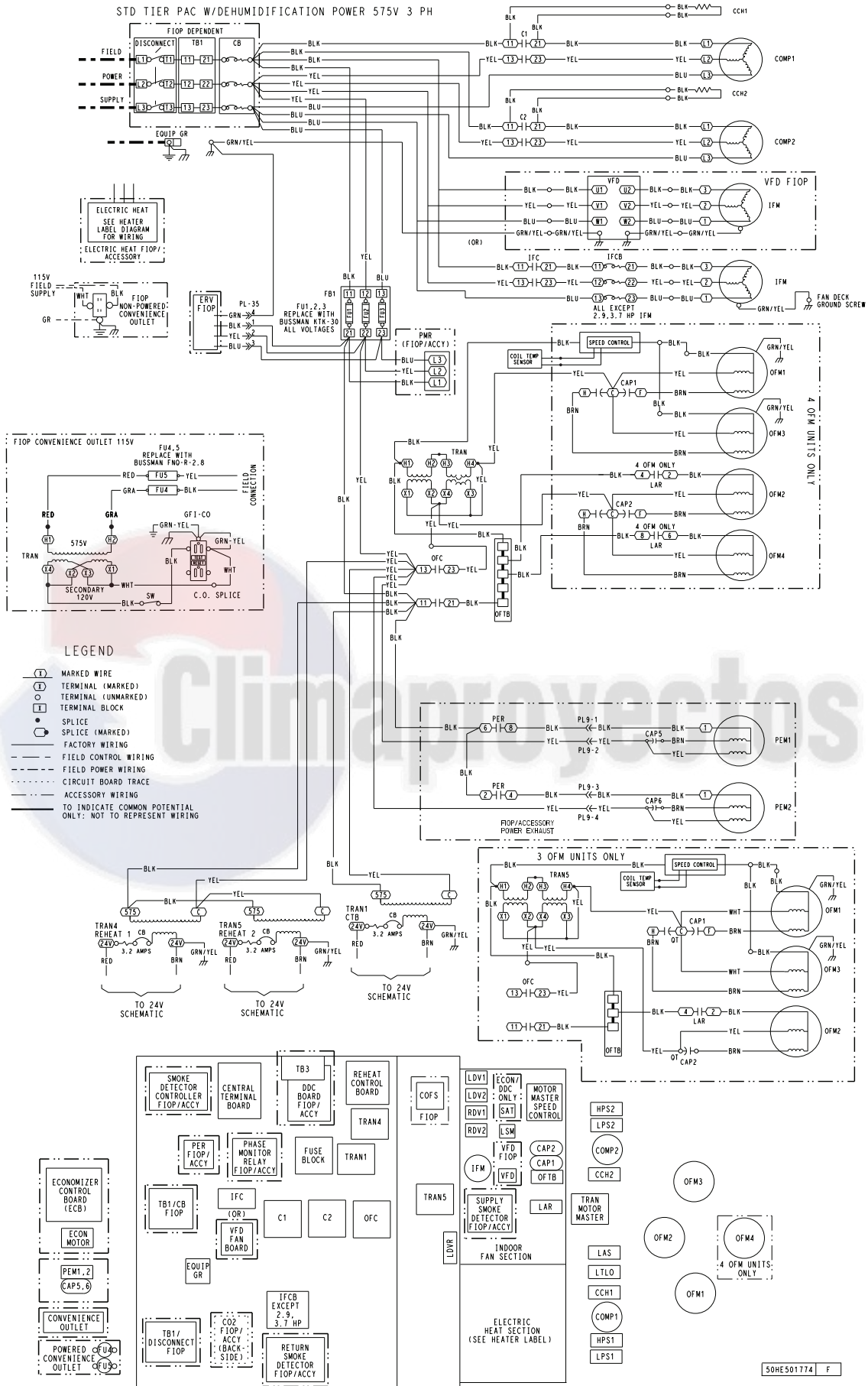

Fig. K — 50TC 17-30 Power Wiring Diagram (575-3-60 Units) with Humidi-MiZer System

APPENDIX D — WIRING DIAGRAMS

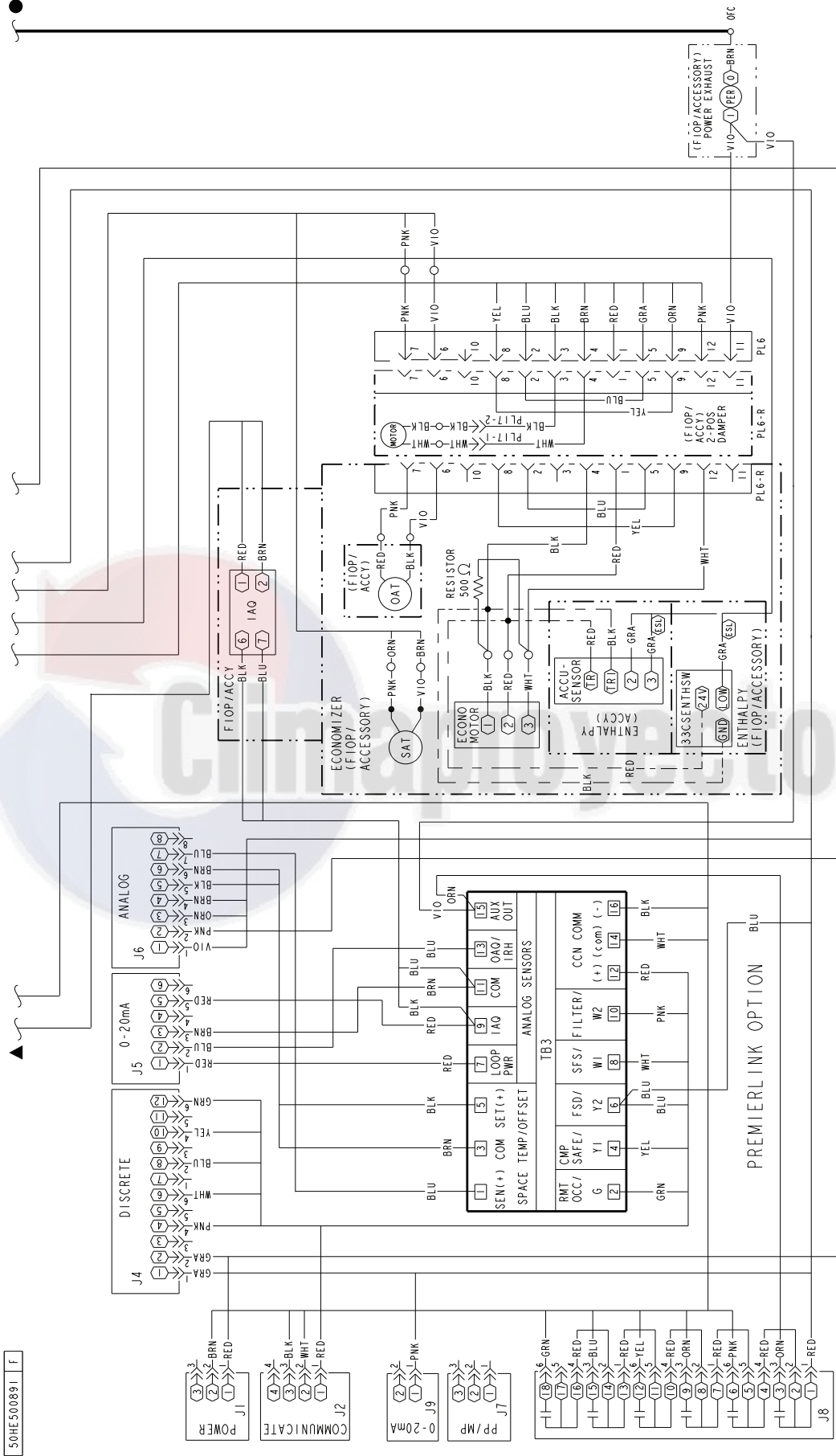

Fig. L — 50TC PremierLink System Wiring Diagram

APPENDIX D — WIRING DIAGRAMS

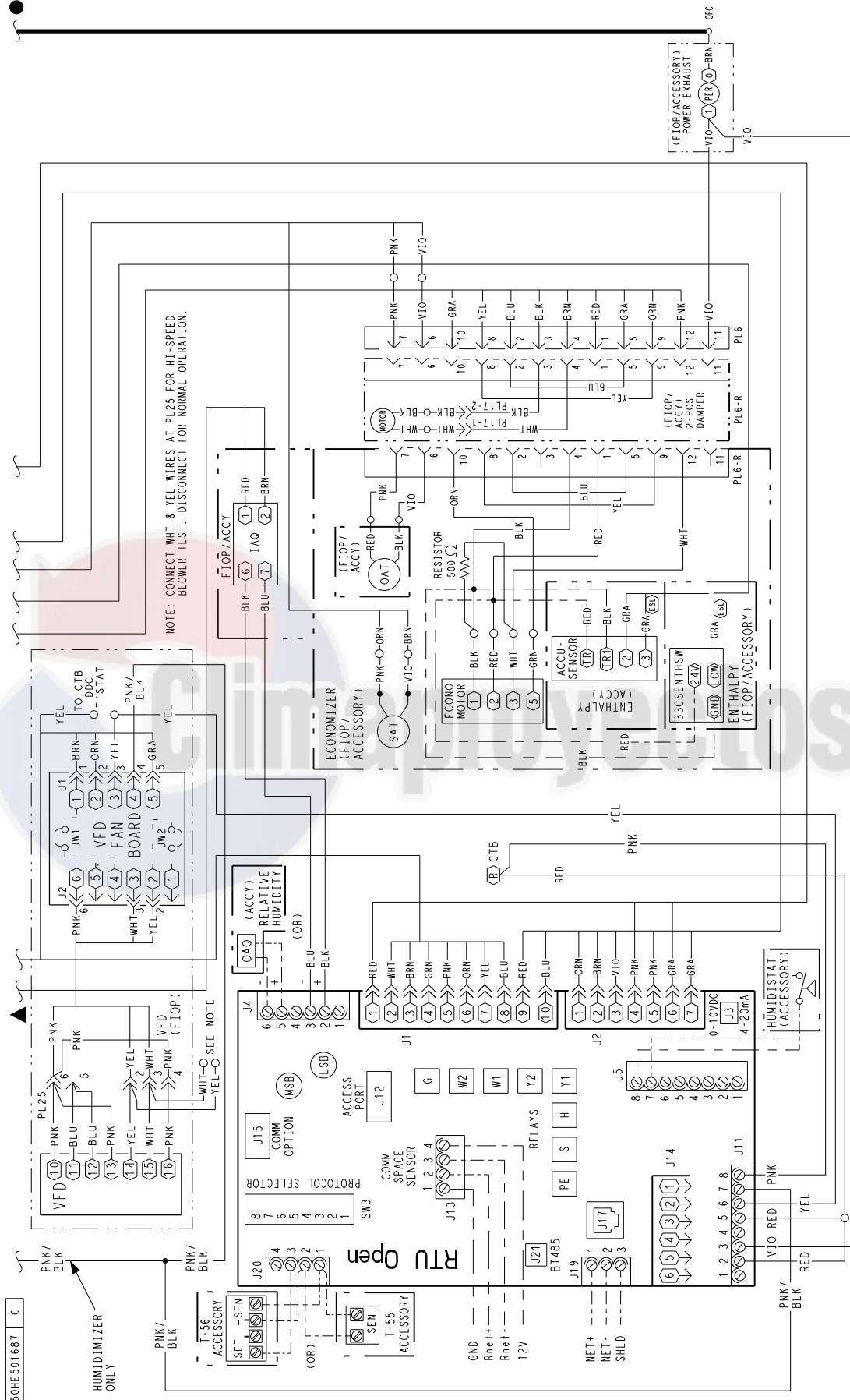

Fig. M — 50TC RTU Open Wiring Diagram

APPENDIX D — WIRING DIAGRAMS

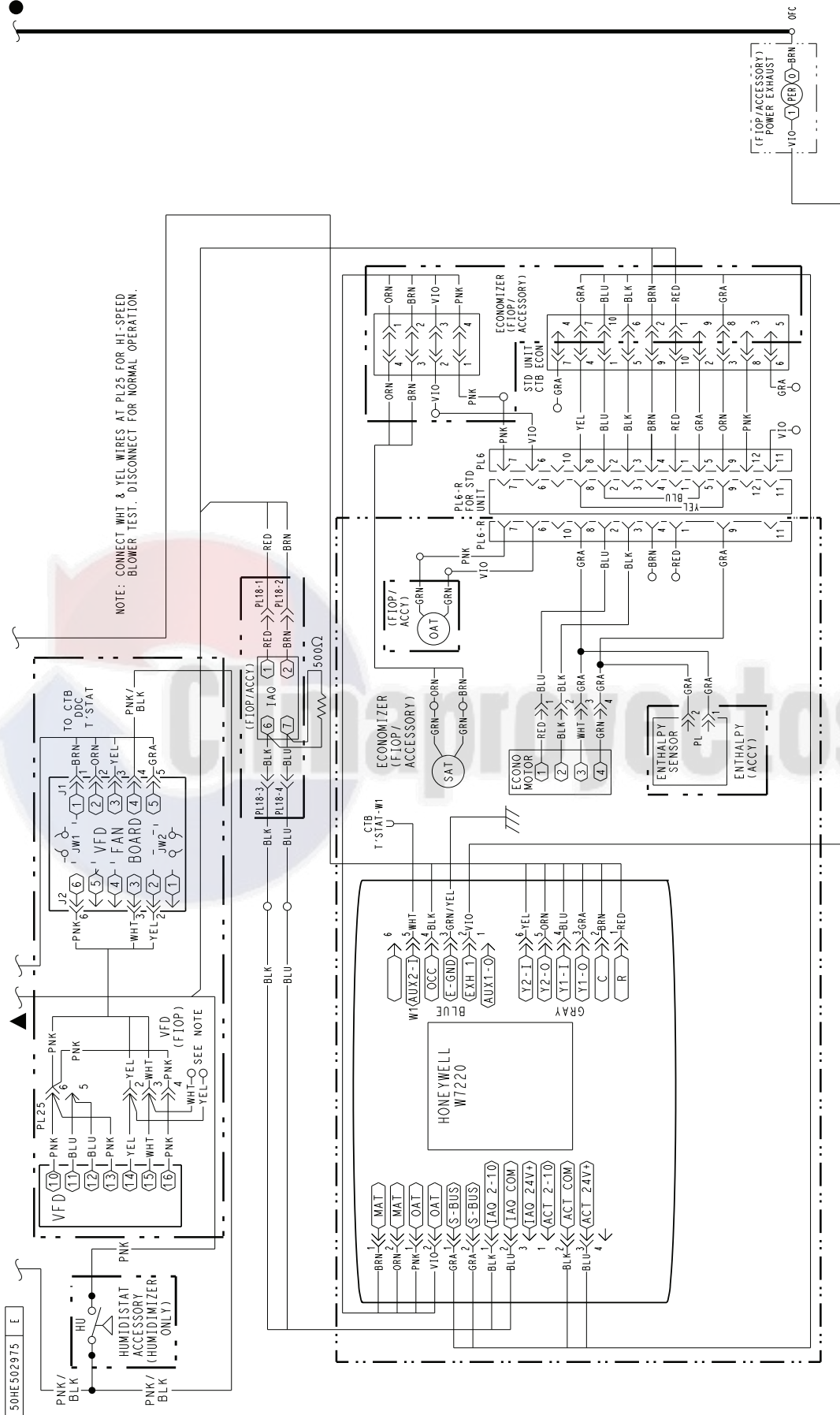

Fig. N — 50TC SAV / VFD System Wiring Diagram

APPENDIX E — MOTORMASTER SENSOR LOCATIONS

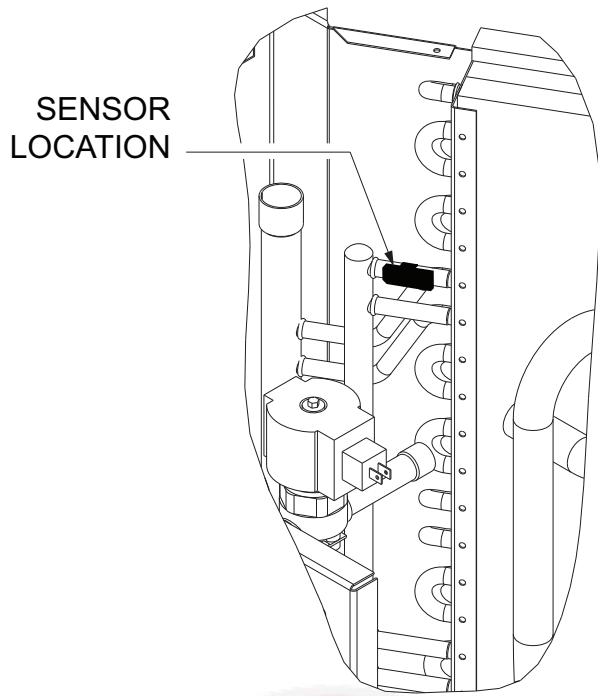

Fig. O — Motormaster Sensor Location (Sizes 17-25)

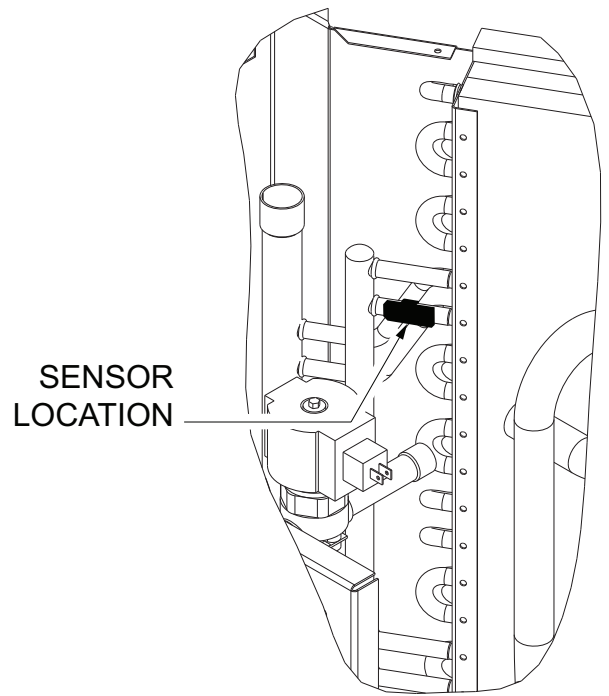
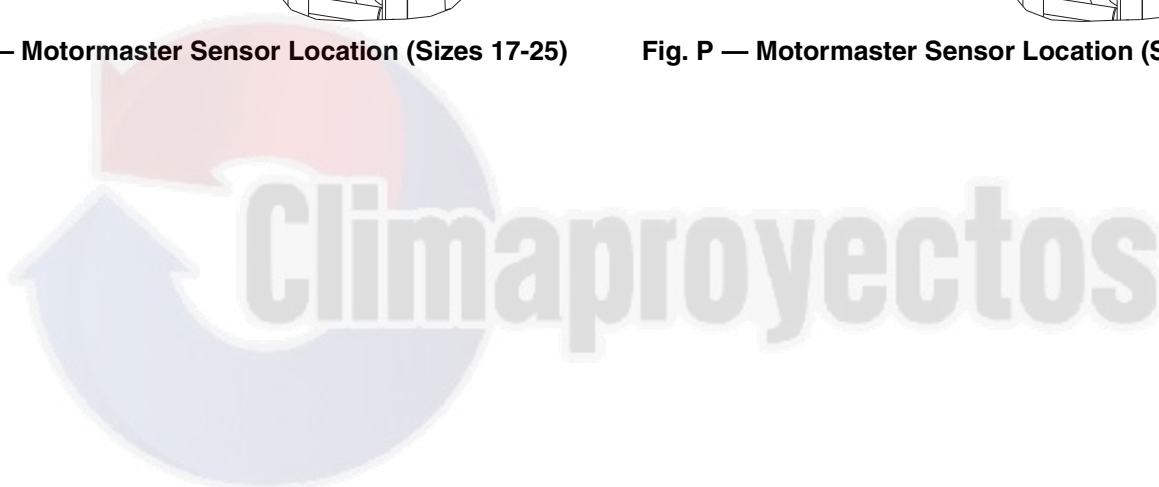

Fig. P — Motormaster Sensor Location (Sizes 28-30)







**START-UP CHECKLIST — 50TC 17-30 SINGLE PACKAGE ROOFTOP WITH
HEAT/ELECTRIC COOLING WITH PURON (R-410A) REFRIGERANT**

NOTE: To avoid injury to personnel and damage to equipment or property when completing the procedures listed in this start-up checklist, use good judgment, follow safe practices, and adhere to the safety considerations/information as outlined in preceding sections of this Service and Maintenance Instruction document.

I. PRELIMINARY INFORMATION

MODEL NO. _____
JOB NAME _____
SERIAL NO. _____
ADDRESS _____
START-UP DATE _____
TECHNICIAN NAME _____
ADDITIONAL ACCESSORIES _____

II. PRE-START-UP

Verify that job site voltage agrees with voltage listed on rating plate (Y/N) _____
Verify that all packaging materials have been removed from unit (Y/N) _____
Remove all shipping hold down bolts and brackets per installation instructions (Y/N) _____
Verify that condensate connection is installed per installation instructions (Y/N) _____
Check refrigerant piping for indications of leaks; investigate and repair if necessary (Y/N) _____
Check all electrical connections and terminals for tightness (Y/N) _____
Check that return (indoor) air filters are clean and in place (Y/N) _____
Verify that unit installation is level (Y/N) _____
Check fan wheels and propeller for location in housing/orifice and setscrew tightness (Y/N) _____
Check to ensure that electrical wiring is not in contact with refrigerant lines or sharp metal edges (Y/N) _____
Check pulley alignment and belt tension per installation instructions (Y/N) _____

III. START-UP

ELECTRICAL

Supply Voltage	L1-L2 _____	L2-L3 _____	L3-L1 _____
Compressor Amps 1	L1 _____	L2 _____	L3 _____
Compressor Amps 2	L1 _____	L2 _____	L3 _____
Indoor Fan Amps	L1 _____	L2 _____	L3 _____
Outdoor Fan Amps	NO.1 _____	NO.2 _____	NO.3 _____
	NO.4 _____	NO.5 _____	NO.6 _____

TEMPERATURES

Outdoor-Air Temperature	_____ °F DB (Dry Bulb)	_____ °F WB (Wet Bulb)
Return-Air Temperature	_____ °F DB	_____ °F WB
Cooling Supply Air Temperature	_____ °F DB	_____ °F WB

