



# Service and Maintenance Instructions

## CONTENTS

	Page
<b>SAFETY CONSIDERATIONS</b> .....	2
<b>UNIT ARRANGEMENT AND ACCESS</b> .....	3
General .....	3
Routine Maintenance .....	3
Filters .....	3
<b>SUPPLY FAN (BLOWER) SECTION</b> .....	4
Supply Fan (Direct-Drive) .....	4
Staged Air Volume .....	10
<b>COOLING</b> .....	10
Condenser Coil (Outdoor) .....	10
Evaporator Coil (Indoor) .....	10
Condenser Coil Maintenance and Cleaning Recommendation .....	10
<b>EVAPORATOR COIL</b> .....	12
Refrigeration System Components .....	12
Evaporator Coil Metering Devices .....	14
<b>THERMOSTATIC EXPANSION VALVE (TXV)</b> .....	14
TXV Operation .....	14
Replacing TXV .....	14
Refrigerant System Pressure Access Ports .....	15
<b>PURON (R-410A) REFRIGERANT</b> .....	15
Refrigerant Charge .....	16
<b>COOLING CHARGING CHARTS</b> .....	16
<b>COMPRESSOR</b> .....	17
Lubrication .....	17
Replacing Compressor .....	18
Compressor Rotation .....	18
Filter Drier .....	18
Condenser-Fan Adjustment .....	18
Troubleshooting Cooling System .....	20
<b>CONVENIENCE OUTLETS</b> .....	21
Convenience Outlets .....	21
Installing Weatherproof Cover .....	21
Non-Powered Type .....	21
Unit-Powered Type .....	21
Duty Cycle .....	22
Maintenance .....	22
Fuse on Powered Type .....	22
<b>COMMERCIAL DEFROST CONTROL</b> .....	22
Reversing Valve Control .....	23
Compressor Control .....	23
Auxiliary (Electric) Heat control .....	23
Defrost .....	24
<b>ELECTRIC HEATERS</b> .....	24
Single Point Boxes and Supplementary Fuses .....	25
Safety Devices .....	25
Completing Heater Installation .....	25
<b>SMOKE DETECTORS</b> .....	26
System .....	26
Controller .....	26
Smoke Detector Sensor .....	26
Smoke Detector Locations .....	26
Completing Installation of Return Air Smoke Detector .....	27
FIOP Smoke Detector Wiring and Response .....	28
<b>SENSOR AND CONTROLLER TESTS</b> .....	29
Sensor Alarm Test .....	29
Controller Alarm Test .....	29
Dirty Controller Test .....	29
Dirty Sensor Test .....	29
Changing the Dirty Sensor Test .....	29
Remote Station Test .....	29
SD-TRM4 Remote Alarm Test Procedure .....	30
Remote Test/Reset Station Dirty Sensor Test .....	30
Dirty Sensor Test Using an SD-TRM4 .....	30
Detector Cleaning .....	30
Indicators .....	30
Troubleshooting .....	31
<b>PROTECTIVE DEVICES</b> .....	32
Compressor Protection .....	32
Relief Device .....	32
Control Circuit, 24-V .....	32
<b>SYSTEMVU CONTROL SYSTEM</b> .....	32
SystemVu Interface .....	32
Additional SystemVu Installation and Troubleshooting .....	32
<b>RTU OPEN CONTROL SYSTEM</b> .....	34
Sensory/Accessory Installation .....	34
Additional RTU Open Installation and Troubleshooting .....	35
<b>ECONOMIZER SYSTEMS</b> .....	35
EconoMi\$er 2 .....	36
EconoMi\$er IV (Field-Installed Accessory) .....	37
EconoMi\$er X (Factory Option) .....	44
<b>PRE-START-UP/START-UP</b> .....	58
<b>START-UP, GENERAL</b> .....	59
Unit Preparation .....	59
Additional Installation/Inspection .....	59
Return-Air Filters .....	59
Outdoor-Air Inlet Screens .....	59
Compressor Mounting .....	59
Internal Wiring .....	59
Refrigerant Service Ports .....	59


Compressor Rotation .....59  
 Refrigerant Service Ports .....59  
 Cooling .....59  
 Heating .....60  
 Ventilation (Continuous Fan) .....60  
**FASTENER TORQUE VALUES .....60**  
**START-UP, RTU OPEN CONTROLS .....60**  
**START-UP, SYSTEMVU CONTROLS .....60**  
**APPENDIX A — MODEL NUMBER**  
**NOMENCLATURE.....61**  
**APPENDIX B — PHYSICAL DATA.....62**  
**APPENDIX C — FAN PERFORMANCE .....64**  
**APPENDIX D — WIRING DIAGRAMS .....93**  
**APPENDIX E — LOW AMBIENT CONTROL**  
**SENSOR LOCATION .....109**  
**START-UP CHECKLIST .....CL-1**

**SAFETY CONSIDERATIONS**


Installation and servicing of air-conditioning equipment can be hazardous due to system pressure and electrical components. Only trained and qualified service personnel should install, repair, or service air-conditioning equipment. Untrained personnel can perform the basic maintenance functions of replacing filters. Trained service personnel should perform all other operations.

When working on air-conditioning equipment, observe precautions in the literature, tags and labels attached to the unit, and other safety precautions that may apply. Follow all safety codes. Wear safety glasses and work gloves. Use quenching cloth for unbrazing operations. Have fire extinguishers available for all brazing operations.


Follow all safety codes. Wear safety glasses and work gloves. Use quenching cloth for brazing operations. Have fire extinguisher available. Read these instructions thoroughly and follow all warnings or cautions attached to the unit. Consult local building codes and National Electrical Code (NEC) for special requirements.

Recognize safety information. This is the safety ALERT symbol . When you see this symbol on the unit and in instructions or manuals, be aware of the potential for physical injury hazards.


Understand the signal words **DANGER**, **WARNING**, and **CAUTION**. These words are used with the safety ALERT symbol. **DANGER** indicates a hazardous situation which, if not avoided, will result in death or severe personal injury. **WARNING** indicates a hazardous situation which, if not avoided, could result in death or personal injury. **CAUTION** indicates a hazardous situation which, if not avoided, could result in minor to moderate injury or product and property damage. **IMPORTANT** is used to address practices not related to physical injury. **NOTE** is used to highlight suggestions which will result in enhanced installation, reliability, or operation.

** WARNING**


**ELECTRICAL OPERATION HAZARD**  
 Failure to follow this warning could result in personal injury or death.  
 Before performing service or maintenance operations on unit, LOCKOUT/TAGOUT the main power switch to unit. Electrical shock and rotating equipment could cause severe injury.

** WARNING**


**ELECTRICAL OPERATION HAZARD**  
 Failure to follow this warning could result in personal injury or death.  
 Units with convenience outlet circuits may use multiple disconnects. Check convenience outlet for power status before opening unit for service. Locate its disconnect switch, if appropriate, and open it. Lock-out and tag-out this switch, if necessary.

** WARNING**


**UNIT OPERATION AND SAFETY HAZARD**  
 Failure to follow this warning could cause personal injury, death and/or equipment damage.  
 R-410A refrigerant systems operate at higher pressures than standard R-22 systems. Do not use R-22 service equipment or components on R-410A refrigerant equipment.

** WARNING**

**FIRE, EXPLOSION HAZARD**  
 Failure to follow this warning could result in death, serious personal injury and/or property damage.  
 Never use air or gases containing oxygen for leak testing or for operating refrigerant compressors. Pressurized mixtures of air or gases containing oxygen can lead to an explosion.

** WARNING**

**FIRE, EXPLOSION HAZARD**  
 Failure to follow this warning could result in death, serious personal injury and/or property damage.  
 Never use non-certified refrigerants in this product. Non-certified refrigerants could contain contaminants that could lead to unsafe operating conditions. Use ONLY refrigerants that conform to AHRI Standard 700.

** CAUTION**

**UNIT DAMAGE HAZARD**  
 Failure to follow this caution may result in reduced unit performance or unit shutdown.  
 High velocity water from a pressure washer, garden hose, or compressed air should never be used to clean a coil. The force of the water or air jet will bend the fin edges and increase airside pressure drop.

**IMPORTANT: Lockout/Tag-out is a term used when electrical power switches are physically locked preventing power to the unit. A placard is placed on the power switch alerting service personnel that the power is disconnected.**

## UNIT ARRANGEMENT AND ACCESS

### General

Figures 1 and 2 show general unit arrangement and access locations.

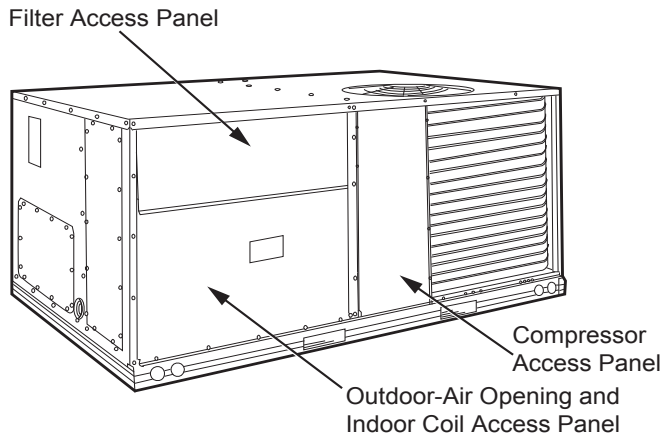


Fig. 1 — Typical Access Panel Locations

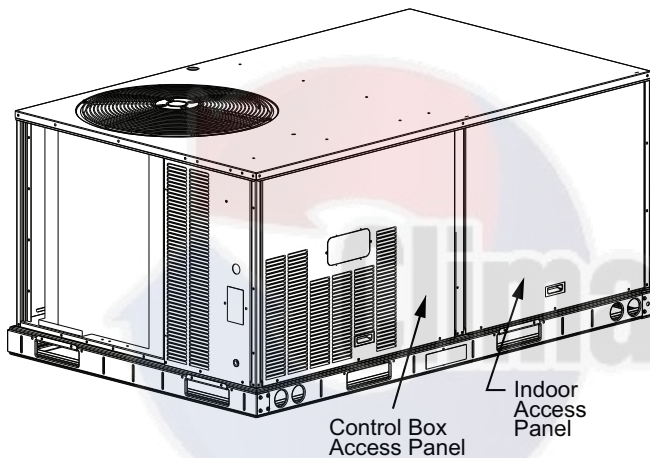


Fig. 2 — Blower Access Panel Location

### Routine Maintenance

These items should be part of a routine maintenance program, to be checked every month or 2, until a specific schedule for each can be identified for this installation:

#### QUARTERLY INSPECTION (AND 30 DAYS AFTER INITIAL START)

- Return air filter replacement
- Outdoor hood inlet filters cleaned
- Condenser coil cleanliness checked
- Condensate drain checked

#### SEASONAL MAINTENANCE

These items should be checked at the beginning of each season (or more often if local conditions and usage patterns dictate):

#### Air Conditioning

- Ensure outdoor fan motor mounting bolts are tight
- Ensure compressor mounting bolts are tight
- Inspect outdoor fan blade positioning
- Ensure control box is clean
- Check control box wiring condition

- Ensure wire terminals are tight
- Check refrigerant charge level
- Ensure indoor coils are clean
- Check supply blower motor amperage

#### Electric Heating

- Inspect power wire connections
- Ensure fuses are operational
- Ensure manual reset limit switch is closed

#### Economizer or Outside Air Damper

- Check inlet filters condition
- Check damper travel (economizer)
- Check gear and dampers for debris and dirt

#### Air Filters and Screens

Each unit is equipped with return air filters. If the unit has an economizer, it will also have an outside air screen. If a manual outside air damper is added, an inlet air screen will also be present.

Each of these filters and screens will need to be periodically replaced or cleaned.

### Filters

#### RETURN AIR FILTERS

#### CAUTION

##### EQUIPMENT DAMAGE HAZARD

Failure to follow this CAUTION can result in premature wear and damage to equipment.

**DO NOT OPERATE THE UNIT WITHOUT THE RETURN AIR FILTERS IN PLACE.**

Dirt and debris can collect on heat exchangers and coils possibly resulting in a small fire. Dirt buildup on components can cause excessive current used resulting in motor failure.

Return air filters are disposable fiberglass media type. Access to the filters is through the small lift-out panel located on the rear side of the unit, above the evaporator/return air access panel. (See Fig. 3.)

To remove the filters:

1. Grasp the bottom flange of the upper panel.
2. Lift up and swing the bottom out until the panel disengages and pulls out.
3. Reach inside and extract the filters from the filter rack.
4. Replace these filters as required with similar replacement filters of same size.

To re-install the access panel:

1. Slide the top of the panel up under the unit top panel.
2. Slide the bottom into the side channels.
3. Push the bottom flange down until it contacts the top of the lower panel (or economizer top).

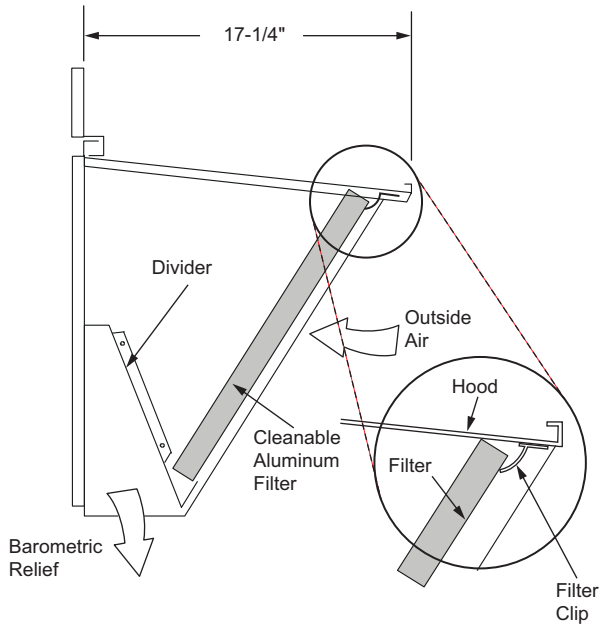
#### OUTSIDE AIR HOOD

Outside air hood inlet screens are permanent aluminum-mesh type filters. Check these for cleanliness. Remove the screens when cleaning is required. Clean by washing with hot low-pressure water and soft detergent and replace all screens before restarting the unit. Observe the flow direction arrows on the side of each filter frame.

#### ECONOMIZER INLET AIR SCREEN

This air screen is retained by filter clips under the top edge of the hood. (See Fig. 3.)

## SUPPLY FAN (BLOWER) SECTION



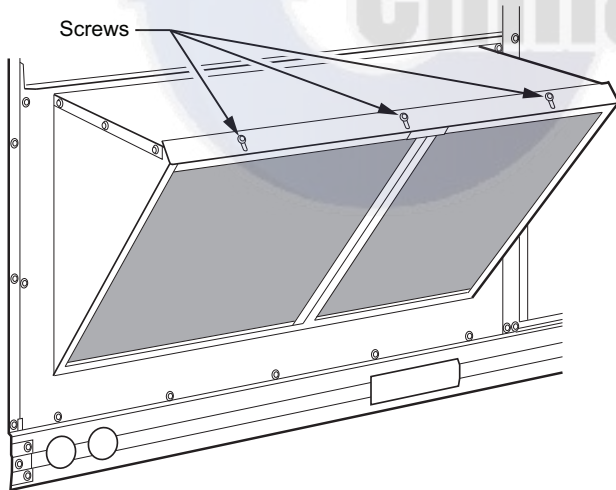
**Fig. 3 – Filter Installation**

To remove the filter, open the filter clips. Re-install the filter by placing the frame in its track, then closing the filter clips.

### MANUAL OUTSIDE AIR HOOD SCREEN

This inlet screen is secured by a retainer angle across the top edge of the hood. (See Fig. 4.)

To remove the screen, loosen the screws in the top retainer and slip the retainer up until the filter can be removed. Re-install by placing the frame in its track, rotating the retainer back down, and tightening all screws.



**Fig. 4 – Screens Installed on Outdoor-Air Hood**

### **⚠ WARNING**

#### ELECTRICAL OPERATION HAZARD

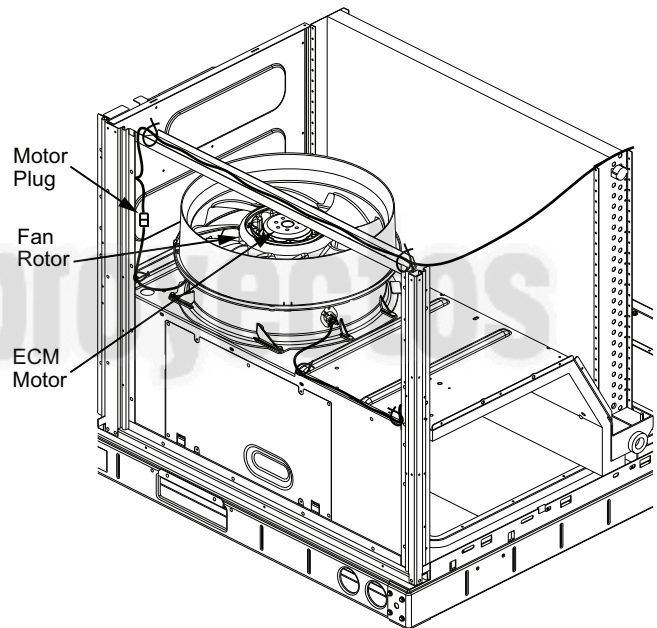
Failure to follow this warning could result in personal injury or death.

Before performing service or maintenance operations on unit, LOCKOUT/TAGOUT the main power switch to unit. Electrical shock and rotating equipment could cause severe injury.

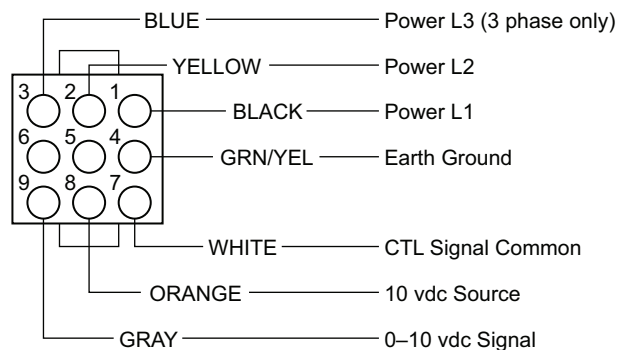
All low-voltage wiring should be routed through the provided raceway built into the corner post of the unit or secured to the unit control box with the electrical conduit in order to provide UL-required clearance between high and low-voltage wiring.

### Supply Fan (Direct-Drive)

All 50FCQ units have the EcoBlue™ direct drive vane axial fan system. The fan is driven by an ECM motor with speed that is user set through the Unit Control Board (UCB). Speeds are fully configurable from 40% to 100% of the motor's maximum speed. See Fig. 5 and 6.



**Fig. 5 – Direct-Drive Supply Fan Assembly**



**Fig. 6 – ECM Motor Plug Connectors**



## EVALUATING MOTOR SPEED

The direct drive ECM blower motor uses a constant speed design. Motor speed is controlled by a 0-10 vdc signal, where 10 vdc is equal to the motor's maximum rpm.

## SELECTING FAN SPEED

All units come factory set for 9.0 vdc or approximately 90% of the motor's maximum speed. Fan speed should be set per job specification cfm (cubic feet per minute) and ESP (external static pressure) required and per Fan Speed Set Up label included on the unit's high voltage cover. In some cases, the Fan Speed Set Up label may already include the field setting if unit was previously installed. Check the box on the lower half of the label to see if the field voltage setting was filled in and if so, set fan speed to that voltage. Otherwise see detailed instructions below.

NOTE: Fan Speed Set Up is for full load airflow. If the unit has multiple stages of cooling, low cool and ventilation may operate at lower fan rpms. This offset is factory set and controlled by the UCB. If fan speed verification is being done with a strobe, fan speed should be verified in all unit operation modes.

### Units with Electro-mechanical controls

The Fan Speed Set Up controls are located on the lower section of the Unit Control Board (UCB). See Fig. 7 for location.

1. Check the job specifications for the cfm (cubic feet per minute) and ESP (external static pressure) required.
2. Using the chart on the Fan Speed Set Up labels (see Fig. 8), calculate the vdc from the cfm and ESP for the base unit.
3. If installing any accessories listed at the bottom of the Fan Speed Set Up label, add accessory vdc to base unit vdc in upper portion of label. For electric heaters use only 1 adder (e.g., 2 stage heater uses only 2 stage adder, not 1 stage plus 2 stage).

NOTE: The Fan Speed Set Up labels are located on the High Voltage cover in the Control Box.

4. Connect a multimeter to the vdc terminals on the UCB.
5. Set the Range Switch to either A, B, or C per the Switch Range table.
6. Using a straight blade screwdriver turn the vdc control dial to fine tune the vdc reading.
7. Record the reading in the Field Setting field.

### Low Speed Fan Adjustment

#### 2-Pin DIP Switch

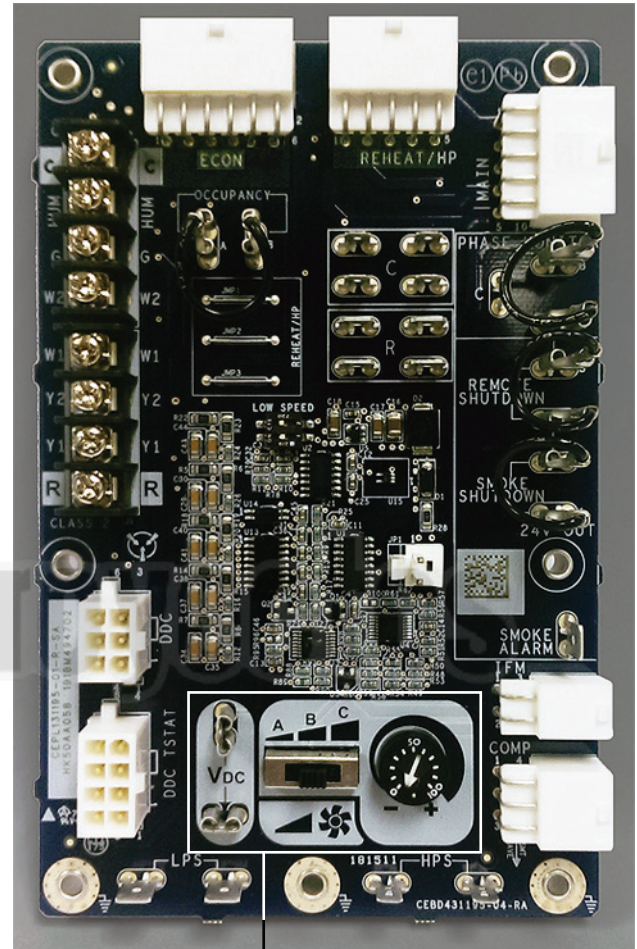
The Low Speed 2-Pin DIP switch is located near the center of the UCB. See Fig. 7.

When replacing UCB, the board will be shipped as default without a low speed selected. To select correct 50FCQ low fan speed for 3 to 5 ton 50FCQ units, set both DIP switches to "OFF" (0). For 6 ton 50FCQ units set both DIP switches "ON" (1). See Table 1.

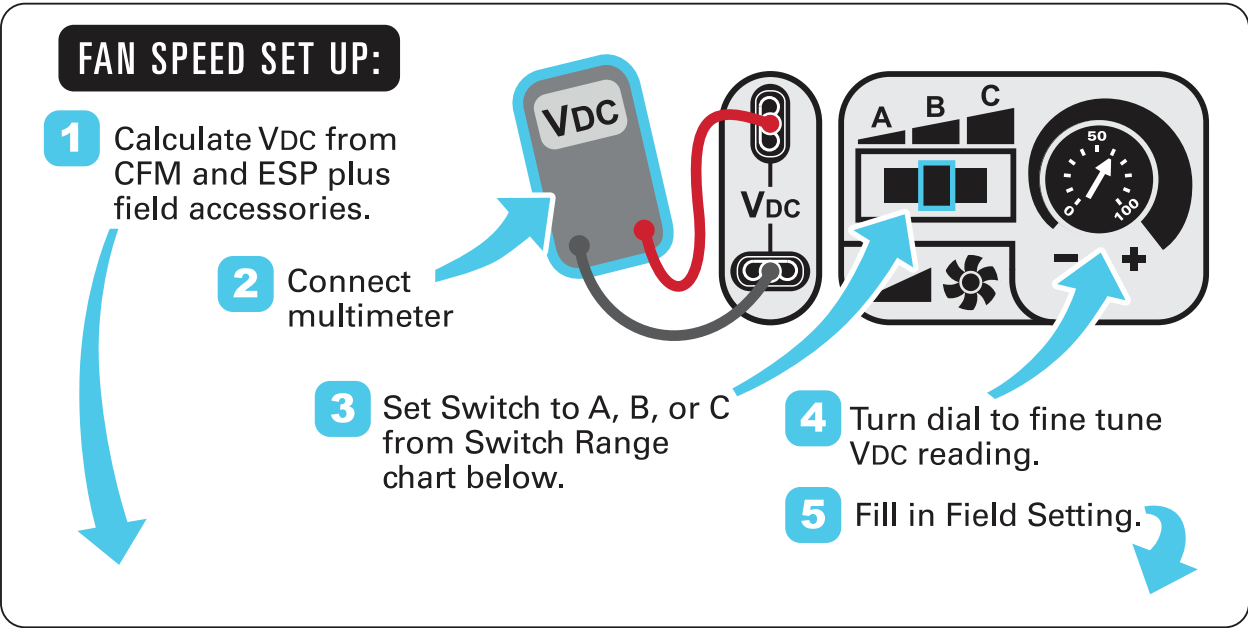
The DIP switch positions can also be found on the unit's control label diagram.

**Table 1 — Low Speed 2-Pin DIP Switch Settings**

LOW SPEED		PERCENTAGE OF USER SET FAN SPEED
DIP1	DIP2	
0	0	100%
0	1	88%
1	0	75%
1	1	66%



**Fig. 7 — UCB Fan Speed Controls**



Vdc Calculator

		ESP in. wg										
		0.2	0.4	0.6	0.8	1.0	1.2	1.4	1.6	1.8	2.0	
UNIT MODEL NUMBER	CFM	1500	5.4	6.2	6.9	7.5	8.1	8.6	9.1	9.6		
		1625	5.8	6.5	7.1	7.7	8.3	8.8	9.3	9.8		
		1750	6.1	6.8	7.4	8.0	8.5	9.0	9.5	9.9		
		1875	6.5	7.1	7.7	8.2	8.7	9.2	9.7			
		2000	6.8	7.4	7.9	8.5	9.0	9.5	9.9			
		2125	7.2	7.7	8.2	8.7	9.2	9.7				
		2250	7.6	8.0	8.5	9.0	9.5	10.0				
		2375	7.9	8.4	8.8	9.3	9.8					
		2500	8.3	8.7	9.2	9.6						
		Field Accessories:										
	Economizer	0.1	0.1	0.1	0.1	0.1	0.1	0.1	0.1			
	1 Stage E Heat	0.2	0.2	0.2	0.2	0.2	0.2	0.2	0.2			
	2 Stage E Heat	0.3	0.3	0.3	0.3	0.3	0.3	0.3	0.3			

**Factory Setting:**  
9.0 Vdc

**Field Setting:**

*Record field setting here*

\_\_\_\_\_ VDC

**Switch Range: \***

	A	B	C
A	4.1 - 7.5		
B		6.9 - 8.7	
C			7.7 - 10.0

\* Overlap in A, B, C switch range designed for maximum field adjustment potential. For example 7.2 can be set at either A or B.

NOTE: Values in the Field Accessories section are vdc adds.

**Fig. 8 — Example of Fan Speed Set Up Labels for Electro-Mechanical Controls**

**Units with SystemVu™ controls**

On units equipped with the factory-installed SystemVu controller the Fan Speed settings are accessed through the SystemVu interface.

1. Check the job specifications for the cfm (cubic feet per minute) and ESP (external static pressure) required.
2. Using the chart on the Fan Speed Set Up labels (see Fig. 9), calculate the rpm from the cfm and ESP for the base unit.
3. If installing any accessories listed at the bottom of the Set Up Label, add accessory rpm to base unit rpm in upper portion of label. For electric heaters use only one adder (e.g., 2 stage heater uses only 2 stage adder, not 1 stage plus 2 stage).

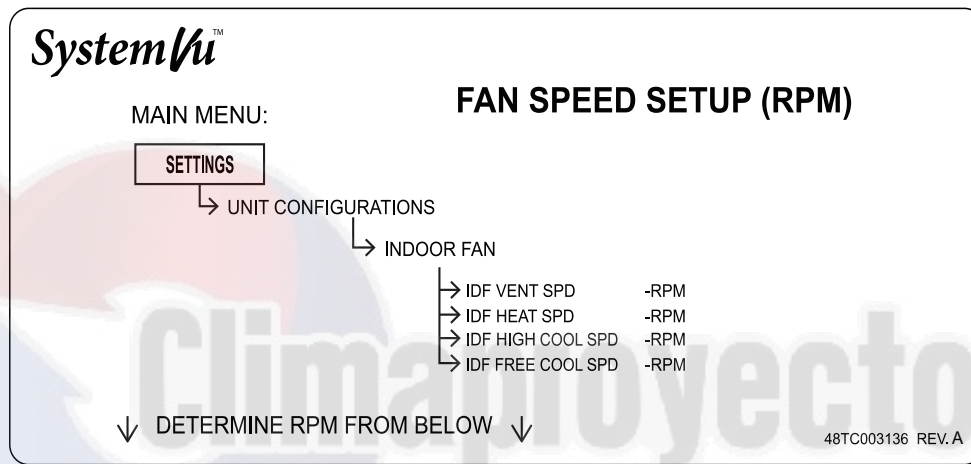
NOTE: The Fan Speed Set Up labels are located on the High Voltage cover in the Control Box.

4. Press any key on the SystemVu interface to activate the display backlight and then press the MENU key.
5. Using the UP and DOWN arrow keys highlight SETTINGS and then press ENTER.

6. Use the DOWN arrow key highlight the UNIT CONFIGURATIONS menu then press ENTER.
7. Highlight UNIT CONFIGURATIONS then press ENTER.
8. Highlight INDOOR FAN and then press ENTER.
9. Refer to the job specifications to set the following, determining the values per the rpm Calculator label (see Fig. 9). Use the UP and DOWN arrow keys and the BACK key to set the values. Press ENTER after setting each value to continue to the next selection.

- IDF VENT SPD
- IDF HEAT SPD
- IDF LOW COOL SPD
- IDF HIGH SPD
- IDF FREE COOL SPD

For further details see the *FC/GC Series Single Package Rooftop Units with SystemVu Controller Controls, Start-up, Operation and Troubleshooting* manual.



RPM Calculator		ESP in. wg										
		0.2	0.4	0.6	0.8	1.0	1.2	1.4	1.6	1.8	2.0	
<b>UNIT MODEL NUMBER</b>	<b>CFM</b>	1500	1301	1477	1639	1788	1925	2054	2174	2289		
	1625	1381	1544	1699	1843	1976	2101	2220	2332			
	1750	1463	1615	1763	1902	2031	2152	2268	2378			
	1875	1548	1688	1828	1962	2087	2206	2318				
	2000	1633	1764	1897	2025	2146	2262	2372				
	2125	1720	1842	1967	2090	2208	2320					
	2250	1808	1921	2040	2157	2271	2380					
	2375	1897	2003	2115	2227	2336						
	2500	1987	2068	2191	2298							
	<b>Field Accessories:</b>											
	<b>Economizer</b>	66	66	66	66	66	66	66	66			
	<b>1 Stage E Heat</b>	80	80	80	80	80	80	80	80			
	<b>2 Stage E Heat</b>	107	107	107	107	107	107	107	107			

NOTE: Values in the Field Accessories section are vdc adders.

**Fig. 9 — Example of Fan Speed Set Up Labels for SystemVu™ Controls**

## TROUBLESHOOTING THE ECM MOTOR

EcoBlue™ motors are designed with several built-in protections included in the motor software. If the motor detects a fault it will safely shut down. For temperature related faults the motor requires a line voltage reset to continue operation. For all others, the motor will resume operation automatically as soon as the fault condition is cleared. See Table 2 for a complete list.

**Table 2 – Fault Condition/Reset Trigger**

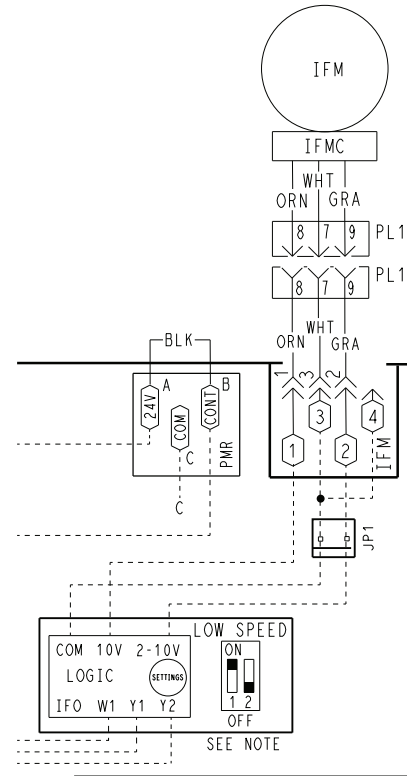
FAULT CONDITION	RESET TRIGGER	DESCRIPTION
Phase Failure	Automatic	One phase is missing or imbalanced. In this case the motor will come to a stop and then automatically restart when all phases are present.
Locked/ Blocked Rotor	Automatic	The rotor is blocked. Once the locking mechanism has been removed, the motor will automatically restart.
Motor Overheated	Manual	The motor will stop in the event the motor overheats. In this case there has to be a manual restart.
Power Module Overheated	Manual	The motor will stop in the event the electronics overheat. In this case there has to be a manual restart.
Line under-voltage	Automatic	Once the line voltage returns within permitted operating range, the fan will automatically restart.
Communication Error	Automatic	Internal communication error of the fan's electronics. The fan will restart automatically, if error is cleared.

Troubleshooting the motor requires a voltmeter.

1. Disconnect main power to the unit.
2. Disconnect motor plug in supply section of the unit.
3. Restore main unit power.
4. Check for proper line voltage at motor power leads Black (PL1-1), Yellow (PL1-2), and Blue (PL1-3). Blue is only present on 3-phase motors. See the following table.

50FCQ UNIT VOLTAGE	MOTOR VOLTAGE	MINIMUM-MAXIMUM VOLTS
208/230	230	190-250
460	230	210-250
575	460	420-500

5. Disconnect main power.
6. Reconnect motor plug in supply section of unit.
7. Restore main power.
8. Check for proper motor control voltage signal of 9.7 vdc to 10.3 vdc at IFM-1 and IFM-3 on Unit Control Board (UCB). See Fig. 10.
9. Using a jumper wire from unit control terminals R to G, engage motor operation.
10. Verify control signal from user speed selection switch by placing voltmeter taps in provided terminals marked vdc. Signal should be between 3.8 vdc and 10.3 vdc.
11. If the motor does not start and run, remove the fan assembly and replace the motor with one having the same part number. Do not substitute with an alternate design motor as the voltage/speed programming will not be the same as that on an original factory motor.



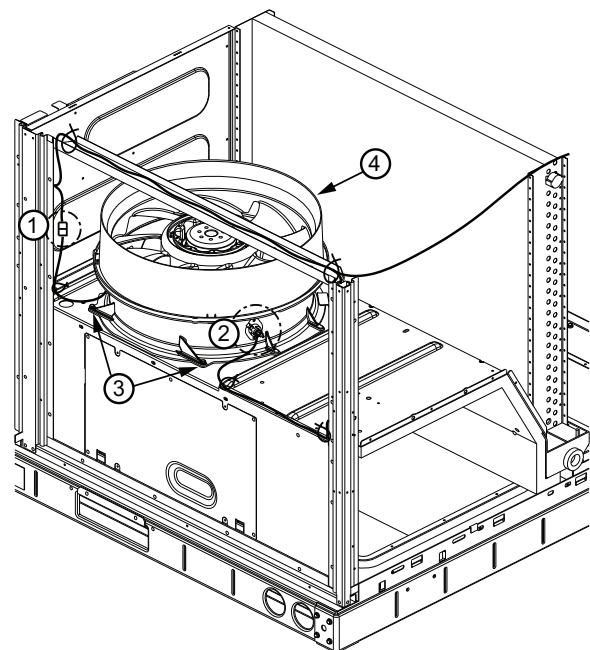
NOTE: 2-PIN LOW SPEED DIP SWITCH POSITIONS ARE FACTORY SET AS SHOWN.

**Fig. 10 – Supply Fan Control Wiring Diagram**

### Removing the Motor and Fan Assembly

NOTE: Due to press fit design of composite Rotor on Motor, it is highly recommended that any time a motor is replaced the fan rotor is replaced as well. The rest of the assembly may be reused. See Fig. 11.

1. Unplug motor harness from control box harness and cut wire tie at the fan deck.
2. Unplug connectors from stator temperature limit switch.
3. Remove 2 screws at front of stator on fan deck.
4. Slide fan assembly forward a couple of inches to clear rear brackets and lift assembly out.



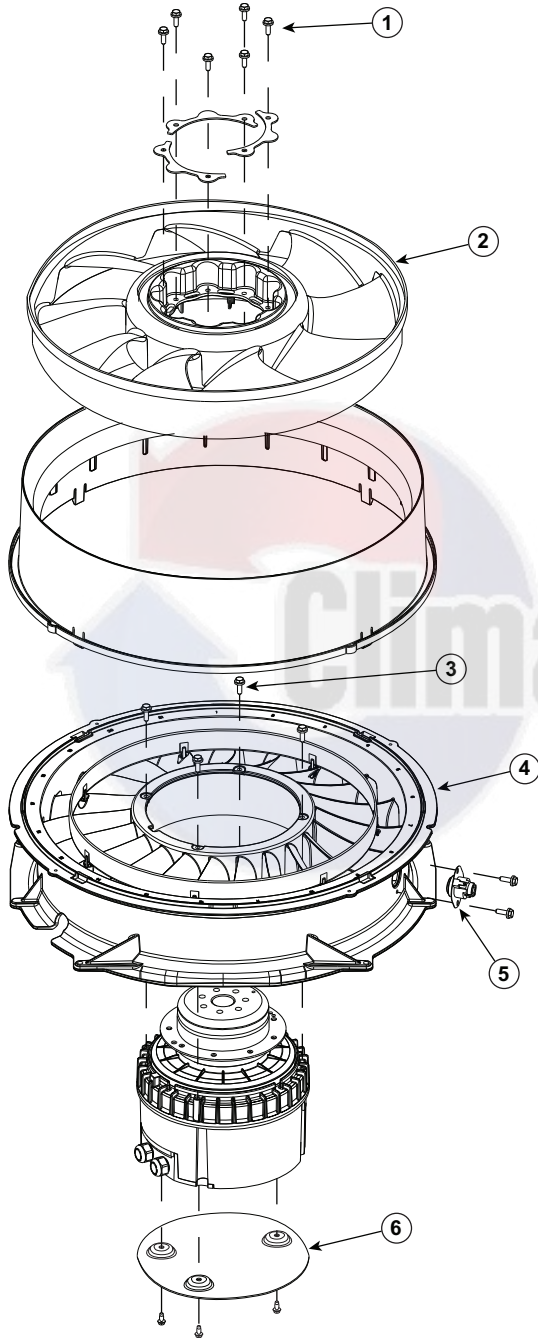
**Fig. 11 – Fan Assembly Removal**



### Disassembling Motor and Fan Assembly

See Fig. 12.

1. Remove 6 screws from retaining rings in the top of the fan rotor.
2. Remove rotor from motor.
3. Remove 4 screws connecting motor to stator flange.
4. Remove stator from motor.
5. If required, remove stator limit switch on aluminum stator.
6. Remove 3 screws from the heat shield. Retain the heat shield if a new heat shield has not been ordered.

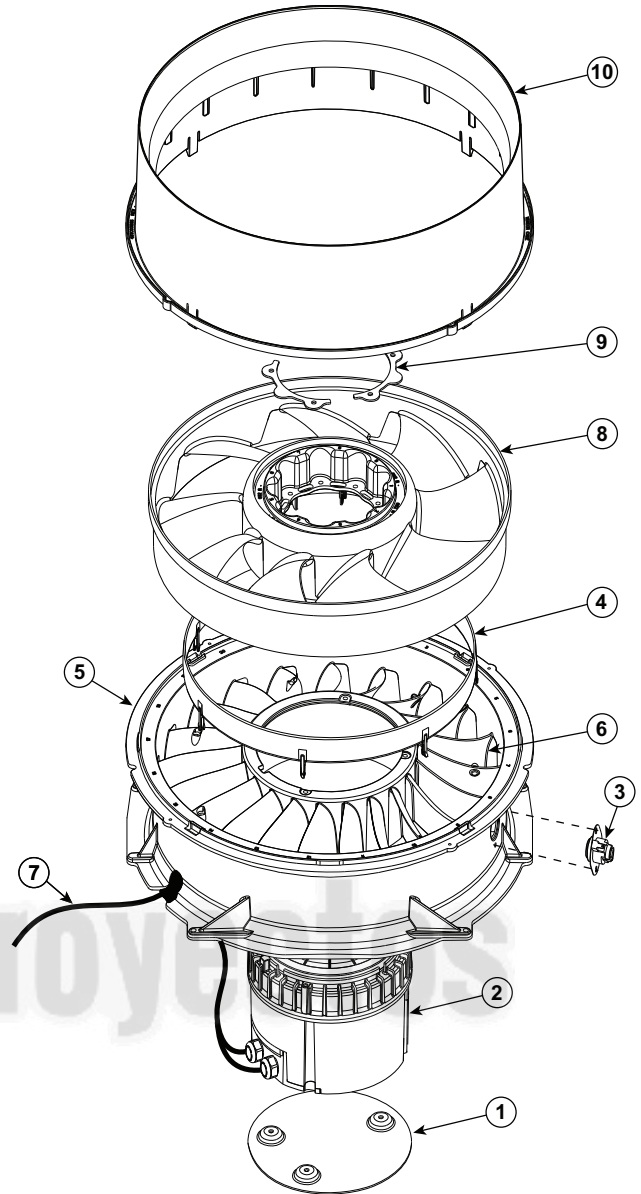


**Fig. 12 — Disassembling Motor and Fan Assembly**

### Reassembly of Motor and Fan Assembly

See Fig. 13.

1. Install heat shield on motor with 3 no. 8-32 x 3/8 in. thread cutting screws (P/N: AK92AB100). Tighten to 30 in.-lb (3.39 Nm).
2. Place motor on flat surface.



**Fig. 13 — Fan System Re-Assembly**

3. If required, install stator limit switch on aluminum stator with 2 no. 10 x 5/8 in. hex head screws (P/N: AL48AM217). Tighten to 50 in.-lb (5.65 Nm).
4. If required, insert composite ring into aluminum stator where pegs match up with holes.
5. Line up rectangle key way in the center of stator with rectangle feature on motor and set stator onto motor.
6. Install 4 no. 10-32 x 1/2 in. hex head machine screws (P/N: AD07AB126) to connect aluminum stator to motor. Tighten to 23 in.-lb (2.6 Nm).
7. Fit grommet on motor wire harness into keyhole feature on the side of the stator and pull wire harness out through grommet.
8. Install rotor on motor by lining up one of 9 holes on composite rotor with one of 9 holes on motor flange. This can be done by adjusting motor and the top of the motor hub and aligning using a 3/16 in. Allen key or similar pin. Press fan rotor down until it is flush with the motor flange.

9. Set retaining rings (x3) into composite rotor and install 6 no. 10-32 x 1/2 in. hex head machine screws (P/N: AD07AB126) through the holes in retaining rings. Tighten to 23 in.-lb (2.6 Nm). It is recommended this screw installation be done in a star pattern.
10. Align tabs of composite casing with rectangular cutouts on top of aluminum stator and snap into place.
11. Final assembly should have a small clearance between top of plastic rotor and underside of casing lip. Spin rotor by hand to ensure no contact or rubbing between these 2 parts.

### Reinstalling Motor and Fan Assembly

See Fig. 14.

1. Align motor harness/grommet at ~7 o'clock (facing installer) and align the bottom flats on right and left sides of fan stator with fan deck ribs. Drop fan assembly down into fan deck opening and slide back until aluminum stator is under the rear fan deck brackets.
2. Align (if necessary) 2 front holes and fasten stator to fan deck with 2 no. 10 x 5/8 in. hex head screws (P/N: AL48AM217). Tighten to 50 in.-lb (5.65 Nm).
3. Reconnect wires for stator temperature limit switch.
4. Pull motor harness tight through grommet and plug it in to the control box harness and secure in the corner with snap-in wire tie.

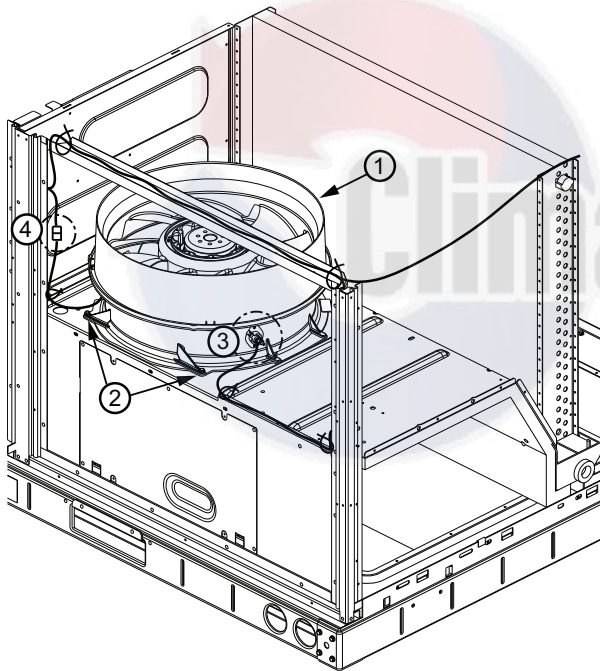


Fig. 14 — Fan Assembly Install

### Staged Air Volume

All 50FCQ\*07 units with EcoBlue™ technology come factory set to automatically adjust the indoor fan motor speed in sequence with the unit's ventilation, cooling, and heating operation. When the first stage of cooling is requested, unit fan will operate at 66% of the user set full load airflow. When the second stage of cooling is required, UCB will allow the full design airflow rate for the unit (100%). During the heating mode, the unit will allow total design airflow rate (100%). During ventilation mode, the fan will operate at 66% speed.

See Table 1 on page 5 for 2-Pin DIP switch settings.

## COOLING

### ⚠ WARNING

#### UNIT OPERATION AND SAFETY HAZARD

Failure to follow this warning could cause personal injury, death and/or equipment damage.

This system uses R-410A refrigerant, which has higher pressures than R-22 and other refrigerants. No other refrigerant may be used in this system. Gauge set, hoses, and recovery system must be designed to handle R-410A refrigerant. If unsure about equipment, consult the equipment manufacturer.

### Condenser Coil (Outdoor)

The condenser coil is fabricated with round tube copper hairpins and plate fins of various materials and/or coatings (see Model Number Nomenclature on page 61 to identify the materials provided in this unit). The coil may be one-row or composite-type 2-row. Composite 2-row coils are 2 single-row coils fabricated with a single return bend end tubesheet.

### Evaporator Coil (Indoor)

The evaporator coil is traditional round-tube, plate-fin technology. Tube and fin construction is of various optional materials and coatings (see Model Number Nomenclature on page 61). Coils are multiple-row.

### Condenser Coil Maintenance and Cleaning Recommendation

Routine cleaning of coil surfaces is essential to maintain proper operation of the unit. Elimination of contamination and removal of harmful residues will greatly increase the life of the coil and extend the life of the unit. The following maintenance and cleaning procedures are recommended as part of the routine maintenance activities to extend the life of the coil.

#### REMOVE SURFACE LOADED FIBERS

Surface loaded fibers or dirt should be removed with a vacuum cleaner. If a vacuum cleaner is not available, a soft non-metallic bristle brush may be used. In either case, the tool should be applied in the direction of the fins. Coil surfaces can be easily damaged (fin edges can be easily bent over and damage to the coating of a protected coil) if the tool is applied across the fins.

NOTE: Use of a water stream, such as a garden hose, against a surface loaded coil will drive the fibers and dirt into the coil. This will make cleaning efforts more difficult. Surface loaded fibers must be completely removed prior to using low velocity clean water rinse.

#### PERIODIC CLEAN WATER RINSE

A periodic clean water rinse is very beneficial for coils that are applied in coastal or industrial environments. However, it is very important that the water rinse is made with a very low velocity water stream to avoid damaging the fin edges. Monthly cleaning as described below is recommended. Rinsing coils in the opposite direction of airflow is recommended.

#### ROUTINE CLEANING OF COIL SURFACES

Periodic cleaning with Totaline® environmentally balanced coil cleaner is essential to extend the life of coils. This cleaner is available from Replacement Components Division as part number P902-0301 for a one gallon container, and part number P902-0305 for a 5 gallon container. It is recommended that all coils, including standard aluminum, pre-coated, copper/copper or e-coated coils be cleaned with the Totaline environmentally balanced coil cleaner as described below. Coil cleaning should be part of the unit's regularly scheduled maintenance procedures to ensure long life of

the coil. Failure to clean the coils may result in reduced durability in the environment.

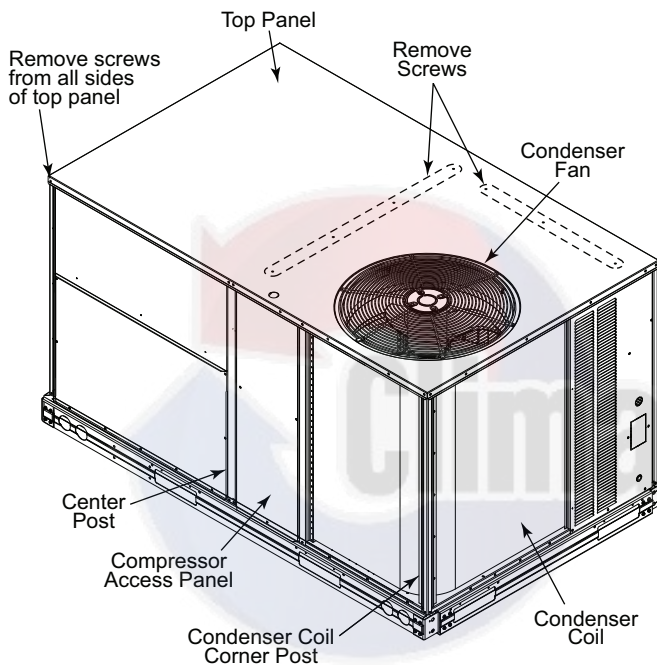
Avoid use of:

- coil brighteners
- acid cleaning prior to painting
- high pressure washers
- poor quality water for cleaning

Totaline environmentally balanced coil cleaner is nonflammable, hypo-allergenic, non-bacterial, and a USDA accepted biodegradable agent that will not harm the coil or surrounding components such as electrical wiring, painted metal surfaces, or insulation. Use of non-recommended coil cleaners is strongly discouraged since coil and unit durability could be affected.

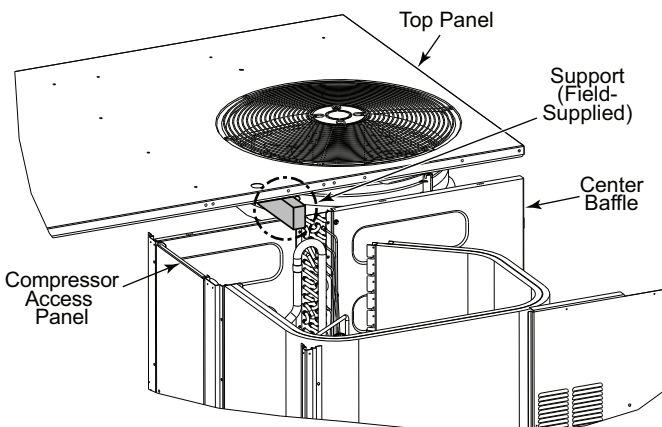
Clean coil as follows:

1. Turn off unit power, tag disconnect.
2. Remove all screws from the top panel except the screws securing the condenser fan to the top panel. See Fig. 15.



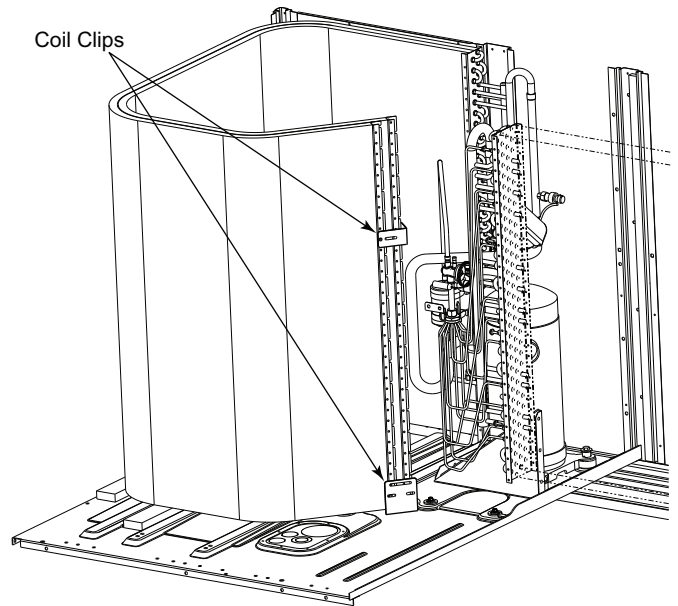
**Fig. 15 — Location of Screws and Coil Corner Post**

3. Lift and rotate the top panel at the condenser fan end and rotate the panel 90 degrees. Support the top panel so it remains level while resting on the condenser fan as shown in Fig. 16.



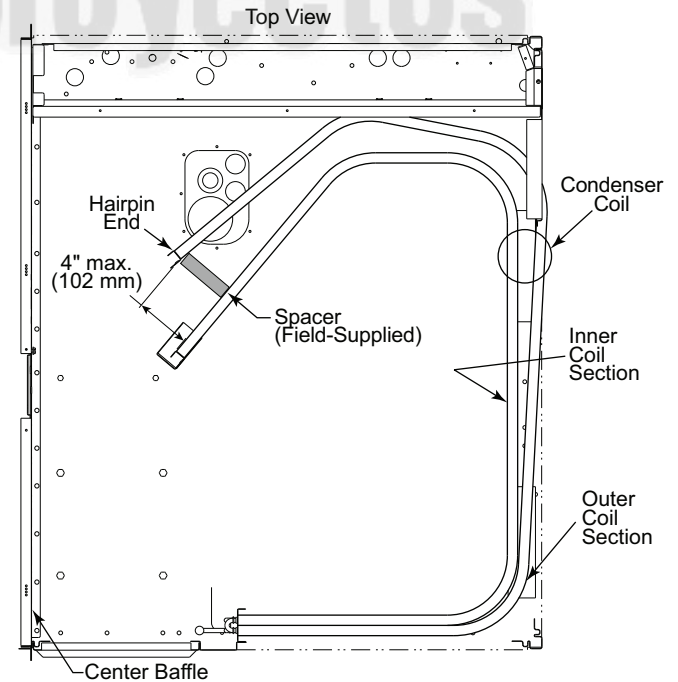
**Fig. 16 — Top Panel Position**

4. Remove the compressor access panel to access the lower coil clip. The condenser coil corner post may also be removed.
5. Remove the screws from both sides of the upper and lower coil retaining clips on the hairpin end of the coil tube sheets. See Fig. 17.



**Fig. 17 — Condenser Coil Clips**

6. Remove the upper and lower retaining clips.
7. Draw the inner coil inward to separate the coils for cleaning.
8. Insert a spacer (field-supplied) between the tube sheets to hold the coils apart. See Fig. 18.



**Fig. 18 — Separating Coil Sections**

9. Clean the outer coil surface to remove surface loaded fibers or dirt. See "Remove Surface Loaded Fibers" on page 10 for details.
10. Use a water hose or other suitable equipment to flush down between the 2 coil sections to remove dirt and



debris. If a coil cleaner is used be sure to rinse the coils completely before reassembly.

11. Move the inner coil back into position. Reinstall the lower and upper coil clips. Reinstall the top panel and replace all screws.

#### Totaline Environmentally Balanced Coil Cleaner Application Equipment

- 2-1/2 gallon garden sprayer
- Water rinse with low velocity spray nozzle

#### **⚠ CAUTION**

##### **UNIT DAMAGE HAZARD**

Failure to follow this caution may result in reduced unit performance or unit shutdown.

High velocity water from a pressure washer, garden hose, or compressed air should never be used to clean a coil. The force of the water or air jet will bend the fin edges and increase airside pressure drop.

#### **⚠ CAUTION**

##### **UNIT DAMAGE HAZARD**

Failure to follow this caution may result in accelerated corrosion of unit parts.

Harsh chemicals, household bleach or acid or basic cleaners should not be used to clean outdoor or indoor coils of any kind. These cleaners can be very difficult to rinse out of the coil and can accelerate corrosion at the fin/tube interface where dissimilar materials are in contact. If there is dirt below the surface of the coil, use the environmentally balanced coil cleaner.

#### Totaline Environmentally Balanced Coil Cleaner Application Instructions

1. Proper eye protection such as safety glasses is recommended during mixing and application.
2. Remove all surface loaded fibers and dirt with a vacuum cleaner as described above.
3. Thoroughly wet finned surfaces with clean water and a low velocity garden hose, being careful not to bend fins.
4. Mix Totaline® environmentally balanced coil cleaner in a 2-1/2 gallon garden sprayer according to the instructions included with the cleaner. The optimum solution temperature is 100°F.

NOTE: DO NOT USE water in excess of 130°F, as the enzymatic activity will be destroyed.

5. Thoroughly apply Totaline environmentally balanced coil cleaner solution to all coil surfaces including finned area, tube sheets, and coil headers.
6. Hold garden sprayer nozzle close to finned areas and apply cleaner with a vertical, up-and-down motion. Avoid spraying in horizontal pattern to minimize potential for fin damage.
7. Ensure cleaner thoroughly penetrates deep into finned areas. Interior and exterior finned areas must be thoroughly cleaned. Finned surfaces should remain wet with cleaning solution for 10 minutes. Ensure surfaces are not allowed to dry before rinsing. Reapply cleaner as needed to ensure 10-minute saturation is achieved.
8. Thoroughly rinse all surfaces with low velocity clean water using downward rinsing motion of water spray nozzle. Protect fins from damage from the spray nozzle.

## **EVAPORATOR COIL**

Cleaning the Evaporator Coil:

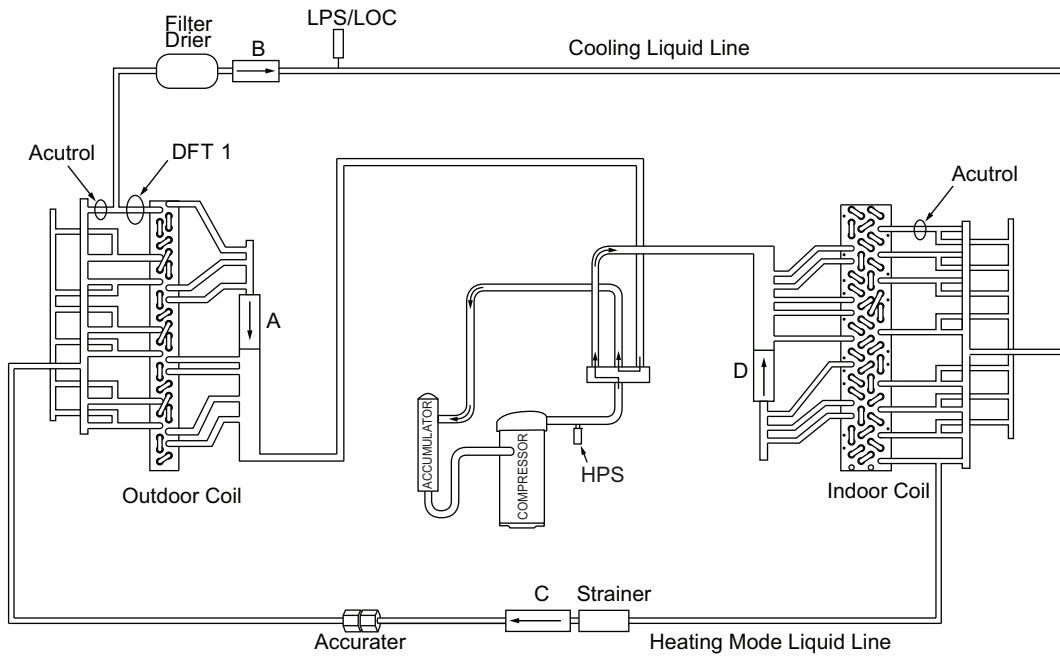
1. Turn unit power off. Install lockout tag. Remove evaporator coil access panel.
2. If economizer or two-position damper is installed, remove economizer by disconnecting Molex®<sup>1</sup> plug and removing mounting screws.
3. Slide filters out of unit.
4. Clean coil using a commercial coil cleaner or dishwasher detergent in a pressurized spray canister. Wash both sides of coil and flush with clean water. For best results, back-flush toward return-air section to remove foreign material. Flush condensate pan after completion.
5. Reinstall economizer and filters.
6. Reconnect wiring.
7. Replace access panels.

## **Refrigeration System Components**

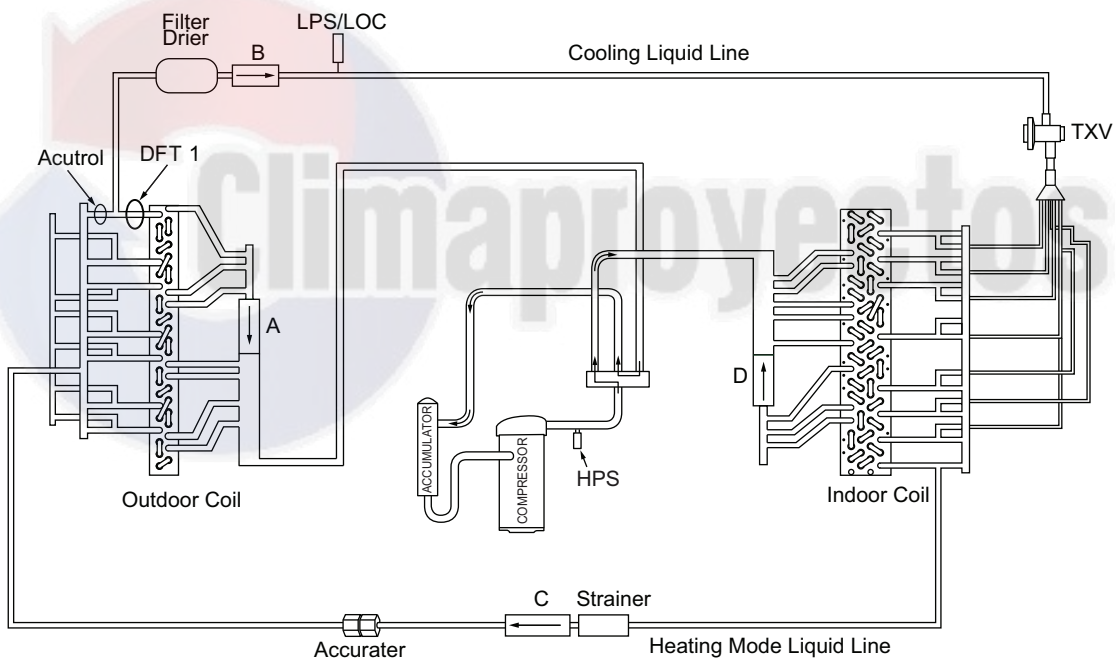
Each heat pump refrigeration system includes a compressor, accumulator, reversing valve, dual-function outdoor coil with vapor header check valve, cooling liquid line with a filter drier and a check valve, dual-function indoor coil with a vapor header check valve, and heating liquid line with a check valve and a strainer. Unit sizes 04-06 have a single compressor-circuit. See Fig. 19 for one-stage cooling units (3 to 5 tons) or Fig. 20 for 2-stage cooling units (6 ton) and Tables 3-5 for typical unit piping schematic. Dual-function outdoor and indoor coils are designed to provide parallel coil circuits during evaporator-function operation and converging coil circuits during the condenser-function operation.

1. Third-party trademarks and logos are the property of their respective owners.





**Fig. 19 — 50FCQ\*04-06 Piping Schematic — One-Stage Cooling**



**Fig. 20 — 50FCQ\*07 Piping Schematic — Two-Stage Cooling, Single Circuit**

**Table 3 — Cooling Mode (each circuit)**

COMPONENTS	STATUS/POSITION
Reversing Valve	Energized
Check Valve A	Closed
Check Valve B	Open
Check Valve C	Closed
Check Valve D	Open

**Table 4 — Heating Mode (each circuit)**

COMPONENTS	STATUS/POSITION
Reversing Valve	De-energized
Check Valve A	Open
Check Valve B	Closed
Check Valve C	Open
Check Valve D	Closed

**Table 5 — Defrost Mode**

COMPONENTS	STATUS/POSITION
Defrost Thermostat	Closed
Outdoor Fan(s)	Off
Reversing Valve	Energized
Check Valve A	Closed
Check Valve B	Open
Check Valve C	Closed
Check Valve D	Open

### Evaporator Coil Metering Devices

Two different evaporator coil metering systems are used on 50FCQ sizes 04-07. 50FCQ\*04-06 units use the Acutrol system for evaporator metering. 50FCQ\*07 units use a TXV-distributor system.

UNIT SIZE	EVAPORATOR METERING
04-06	Acutrol
07	TXV

Check the unit's information data plate for Position 6 value, then compare this value to the Model Number Nomenclature on page 61 to confirm the unit's construction.

The metering devices are multiple fixed-bore devices (Acutrol) swaged into the horizontal outlet tubes from the liquid header, located at the entrance to each evaporator coil circuit path. These are non-adjustable. Service requires replacing the entire liquid header assembly.

To check for possible blockage of one or more of these metering devices, jumper R to Y1 without the G terminal jumpered, then start the compressor and observe the frosting pattern on the face of the evaporator coil. A frost pattern should develop uniformly across the face of the coil starting at each horizontal header tube. Failure to develop frost at an outlet tube can indicate a plugged or missing orifice.

### THERMOSTATIC EXPANSION VALVE (TXV)

All 50FCQ\*07 units include TXV control. The TXV is a bi-flow, bleed port expansion valve with an external equalizer. The TXVs

are specifically designed to operate with Puron® refrigerant (R-410A). Use only factory-authorized TXVs.

### TXV Operation

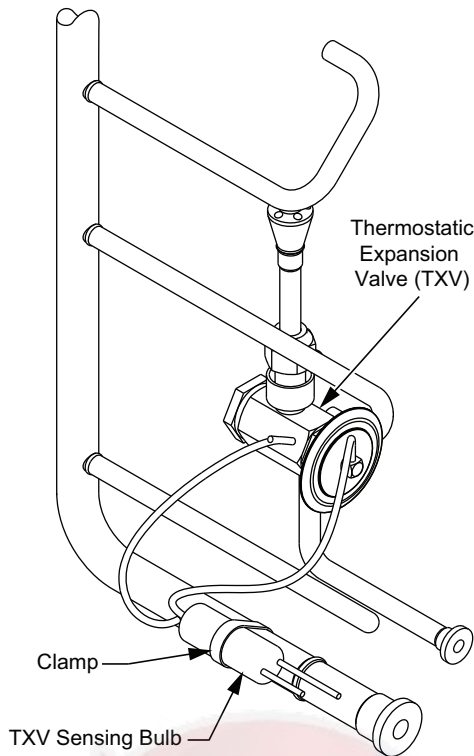
The TXV is a metering device that is used in air conditioning and heat pump systems to adjust to the changing load conditions by maintaining a preset superheat temperature at the outlet of the evaporator coil.

The volume of refrigerant metered through the valve seat is dependent upon the following:

1. Superheat temperature is sensed by cap tube sensing bulb on suction tube at outlet of evaporator coil. This temperature is converted into pressure by refrigerant in the bulb pushing downward on the diaphragm, which opens the valve using the push rods.
2. The suction pressure at the outlet of the evaporator coil is transferred through the external equalizer tube to the underside of the diaphragm.
3. The pin is spring loaded, which exerts pressure on the underside of the diaphragm. Therefore, the bulb pressure works against the spring pressure and evaporator suction pressure to open the valve. If the load increases, the temperature increases at the bulb, which increases the pressure on the top side of the diaphragm. This opens the valve and increases the flow of refrigerant. The increased refrigerant flow causes the leaving evaporator temperature to decrease. This lowers the pressure on the diaphragm and closes the pin. The refrigerant flow is effectively stabilized to the load demand with negligible change in superheat.

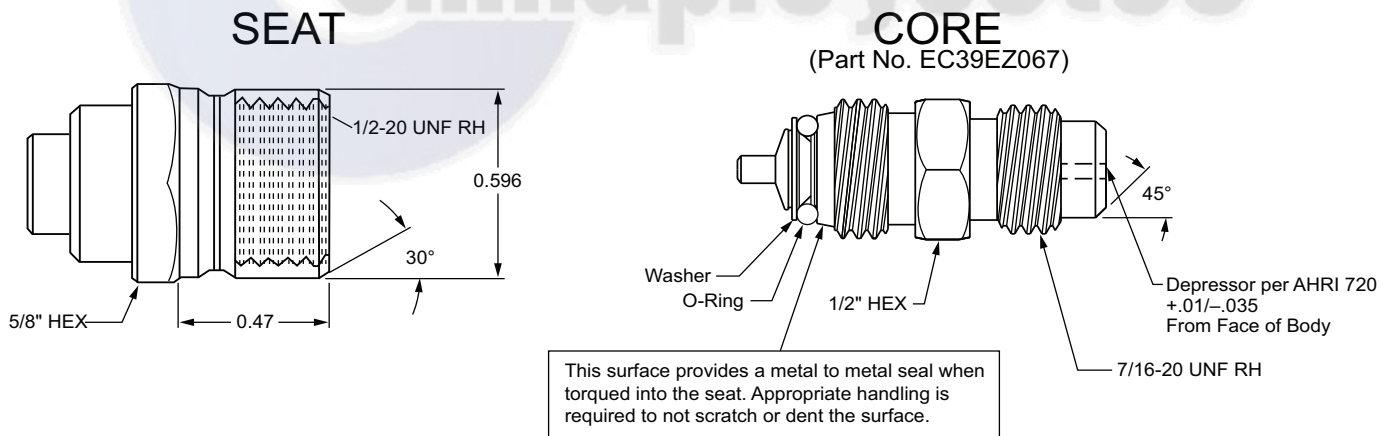
### Replacing TXV

1. Recover refrigerant.
2. Remove TXV support clamp using a 5/16 in. nut driver.
3. Remove TXV using a wrench and an additional wrench on connections to prevent damage to tubing.
4. Remove equalizer tube from suction line of coil. Use file or tubing cutter to cut brazed equalizer line approximately 2 inches above suction tube.
5. Remove bulb from vapor tube inside cabinet.
6. Install the new TXV using a wrench and an additional wrench on connections to prevent damage to tubing while attaching TXV to distributor.
7. Attach the equalizer tube to the suction line. If the coil has a mechanical connection, then use a wrench and an additional wrench on connections to prevent damage. If the coil has a brazed connection, use a file or a tubing cutter to remove the mechanical flare nut from the equalizer line. Then use a new coupling to braze the equalizer line to the stub (previous equalizer line) in suction line.
8. Attach TXV bulb in the same location where the original (in the sensing bulb indent) was when it was removed, using the supplied bulb clamps. See Fig. 21 on page 15.
9. Route equalizer tube through suction connection opening (large hole) in fitting panel and install fitting panel in place.
10. Sweat the inlet of TXV marked "IN" to the liquid line. Avoid excessive heat which could damage the TXV valve. Use quenching cloth when applying heat anywhere on TXV.



NOTE: Sensing bulb insulation removed for clarity.

**Fig. 21 — TXV Valve and Sensing Bulb Location**



**Fig. 22 — CoreMax<sup>®1</sup> Access Port Assembly**

## Refrigerant System Pressure Access Ports

There are 2 access ports in the system: on the suction tube near the compressor and on the discharge tube near the compressor. These are brass fittings with black plastic caps. The hose connection fittings are standard 1/4 in. SAE male flare couplings.

The brass fittings are 2-piece high flow valves, with a receptacle base brazed to the tubing and an integral spring-closed check valve core screwed into the base. See Fig. 22. This check valve is permanently assembled into this core body and cannot be serviced separately; replace the entire core body if necessary. Service tools are available from RCD that allow the replacement of the check valve core without having to recover the entire system refrigerant charge. Apply compressor refrigerant oil to the check valve core's bottom o-ring. Install the fitting body with  $96 \pm 10$  in.-lb ( $10.85 \pm 1.1$  Nm) of torque; do not over-tighten.

## PURON (R-410A) REFRIGERANT

This unit is designed for use with Puron<sup>®</sup> (R-410A) refrigerant. Do not use any other refrigerant in this system.

Puron (R-410A) refrigerant is provided in pink (rose) colored cylinders. These cylinders are available with and without dip tubes; cylinders with dip tubes will have a label indicating this feature. For a cylinder with a dip tube, place the cylinder in the upright position (access valve at the top) when removing liquid refrigerant for charging. For a cylinder without a dip tube, invert the cylinder (access valve on the bottom) when removing liquid refrigerant.

Because Puron (R-410A) refrigerant is a blend, it is strongly recommended that refrigerant always be removed from the cylinder as a liquid. Admit liquid refrigerant into the system in the discharge line. If adding refrigerant into the suction line, use a commercial metering/expansion device at the gauge manifold; remove liquid from the cylinder, pass it through the metering device at the gauge set and then pass it into the suction line as a vapor. Do not remove Puron (R-410A) refrigerant from the cylinder as a vapor.

1. Third-party trademarks and logos are the property of their respective owners.

## Refrigerant Charge

Amount of refrigerant charge is listed on the unit's nameplate. Refer to *Carrier GTAC2-5 Charging, Recovery, Recycling and Reclamation* training manual and the following procedures.

Unit panels must be in place when unit is operating during the charging procedure.

### NO CHARGE

Use standard evacuating techniques. After evacuating system, weigh in the specified amount of refrigerant.

### LOW-CHARGE COOLING

Using Cooling Charging Charts, Fig. 23-27, vary refrigerant until the conditions of the appropriate chart are met. Note the charging charts are different from type normally used. Charts are based on charging the units to the correct sub-cooling for the various operating conditions. Accurate pressure gauge and temperature sensing device are required. Connect the pressure gauge to the service port on the liquid line. Mount the temperature sensing device on the liquid line and insulate it so that outdoor ambient temperature does not affect the reading. Indoor-air cfm must be within the normal operating range of the unit.

50FCQ SIZE DESIGNATION	NOMINAL TONS REFERENCE
04	3
05	4
06	5
07	6

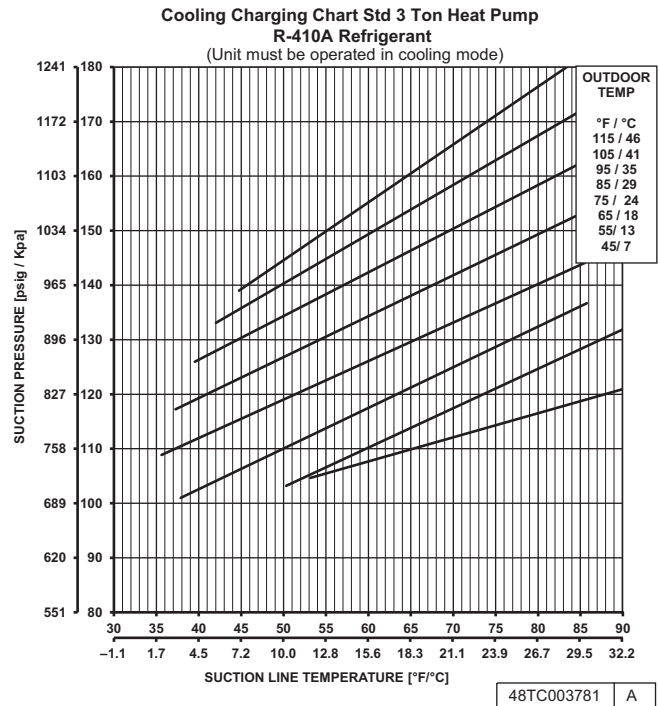
### EXAMPLE:

Model	50FCQA04
Outdoor Temperature	85°F (29°C)
Suction Pressure	140 psig (965 kPa)
Suction Temperature should be	65°F (16°C)

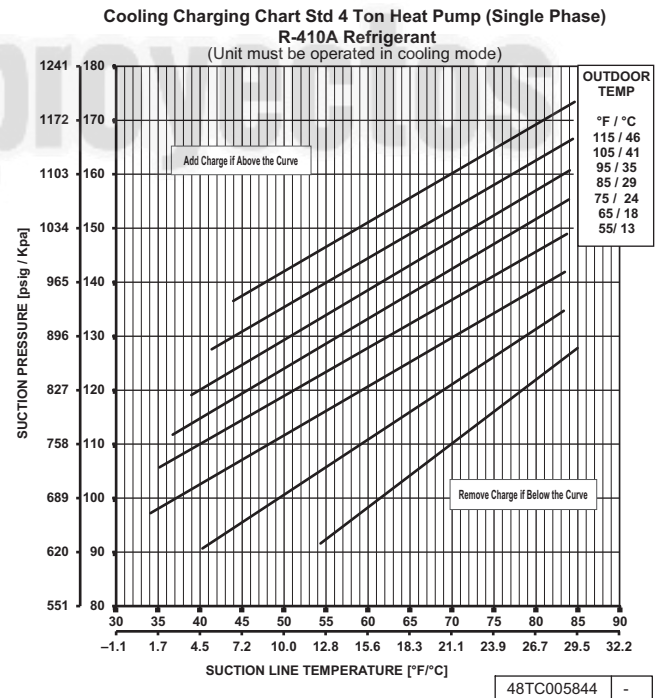
### USING COOLING CHARGING CHARTS

Take the outdoor ambient temperature and read the liquid pressure gauge. Refer to chart to determine what liquid temperature should be. If liquid temperature is low, add refrigerant. If liquid temperature is high, carefully recover some of the charge. Recheck the liquid pressure as charge is adjusted.

## COOLING CHARGING CHARTS

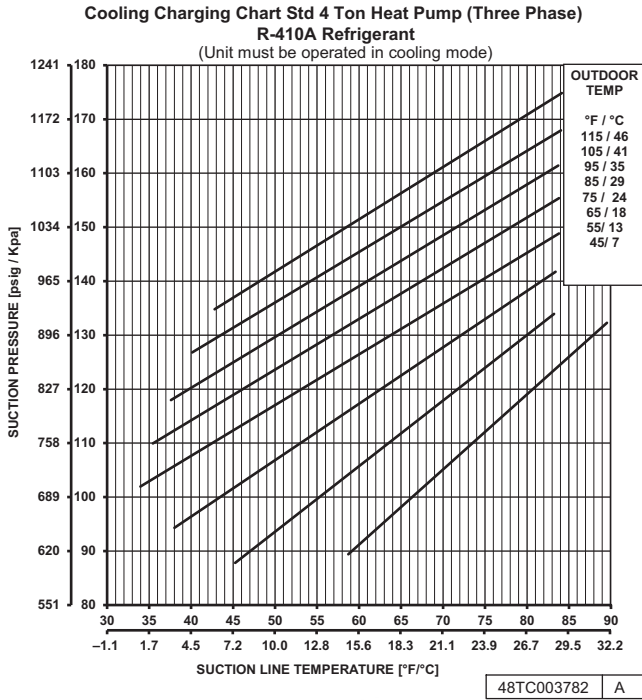


**Fig. 23 — Cooling Charging Chart — 3 Ton, 50FCQA04**

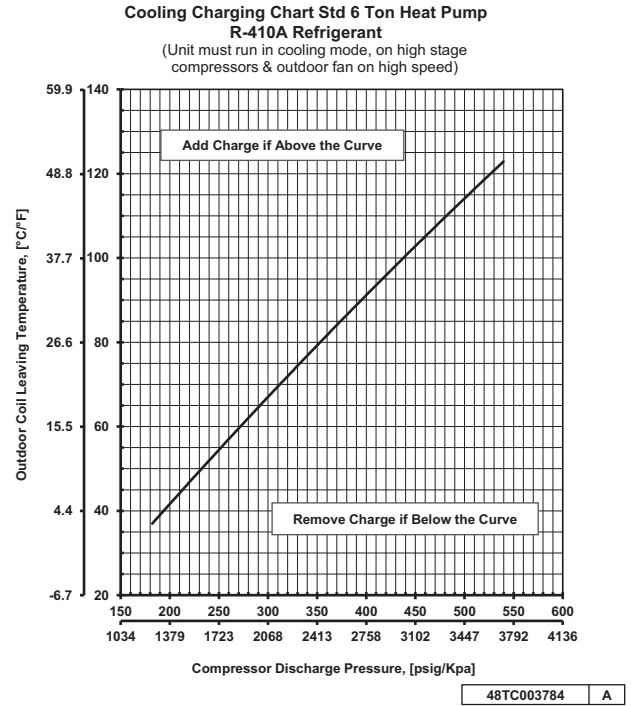


**Fig. 24 — Cooling Charging Chart — 4 Ton, 50FCQC05**

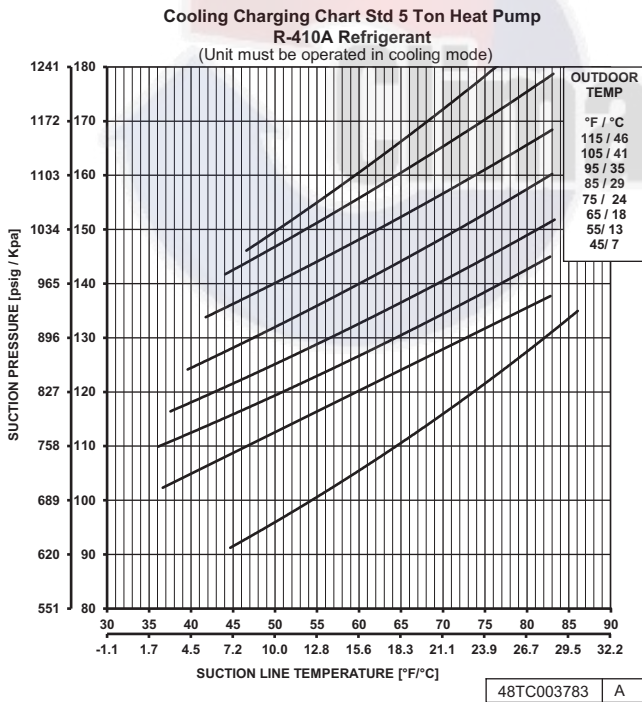




**Fig. 25 — Cooling Charging Chart — 4 Ton, 50FCQA05**



**Fig. 27 — Cooling Charging Chart — 6 Ton, 50FCQM07**



**Fig. 26 — Cooling Charging Chart — 5 Ton, 50FCQA06**

## COMPRESSOR

### Lubrication

The compressor is charged with the correct amount of oil at the factory.

#### ⚠ CAUTION

##### UNIT DAMAGE HAZARD

Failure to follow this caution may result in damage to components.

The compressor is in a R-410A refrigerant system and uses a polyolester (POE) oil. This oil is extremely hygroscopic, meaning it absorbs water readily. POE oils can absorb 15 times as much water as other oils designed for HCFC and CFC refrigerants. Avoid exposure of the oil to the atmosphere.

#### ⚠ WARNING

##### FIRE, EXPLOSION HAZARD

Failure to follow this warning could result in death, serious personal injury and/or property damage.

Never use air or gases containing oxygen for leak testing or for operating refrigerant compressors. Pressurized mixtures of air or gases containing oxygen can lead to an explosion.

**⚠ WARNING**

**FIRE, EXPLOSION HAZARD**

Failure to follow this warning could result in death, serious personal injury and/or property damage.

Never use non-certified refrigerants in this product. Non-certified refrigerants could contain contaminants that could lead to unsafe operating conditions. Use ONLY refrigerants that conform to AHRI Standard 700.

**Replacing Compressor**

NOTE: Only factory-trained service technicians should remove and replace compressor units.

**⚠ CAUTION**

**INSTALLATION SITE DAMAGE**

Failure to follow this caution can result in damage to equipment location site.

R-410A refrigerant contains polyolester (POE) oil that can damage the roof membrane. Caution should be taken to prevent POE oil from spilling onto the roof surface.

The factory also recommends that the suction and discharge lines be cut with a tubing cutter instead of using a torch to remove brazed fittings.

**Compressor Rotation**

**⚠ CAUTION**

**EQUIPMENT DAMAGE HAZARD**

Failure to follow this caution can result in premature wear and damage to equipment.

Scroll compressors can only compress refrigerant if rotating in the right direction. Reverse rotation for extended times can result in internal damage to the compressor. Scroll compressors are sealed units and cannot be repaired on site location.

NOTE: When the compressor is rotating in the wrong direction, the unit makes an elevated level of noise and does not provide cooling.

On 3-phase units with scroll compressors, it is important to be certain compressor is rotating in the proper direction. To determine whether or not compressor is rotating in the proper direction:

1. Connect service gauges to suction and discharge pressure fittings.
2. Energize the compressor.

3. The suction pressure should drop and the discharge pressure should rise, as is normal on any start-up.

NOTE: If the suction pressure does not drop and the discharge pressure does not rise to normal levels, the evaporator fan is probably also rotating in the wrong direction.

4. Turn off power to the unit.
5. Reverse any 2 of the 3 unit power leads.
6. Reapply electrical power to the compressor. The suction pressure should drop and the discharge pressure should rise which is normal for scroll compressors on start-up.
7. Replace compressor if suction/discharge pressures are not within specifications for the specific compressor.

The suction and discharge pressure levels should now move to their normal start-up levels.

**Filter Drier**

Replace whenever refrigerant system is exposed to atmosphere. Only use factory specified liquid-line filter driers with working pressures no less than 650 psig (4482 kPa).

**⚠ CAUTION**

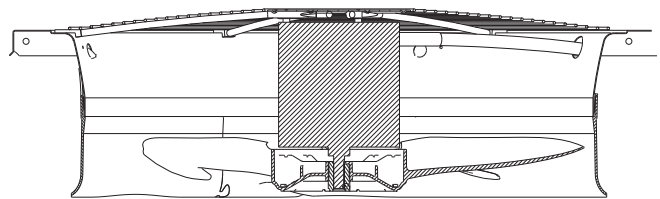
**EQUIPMENT DAMAGE**

Failure to follow this caution can result in equipment damage.

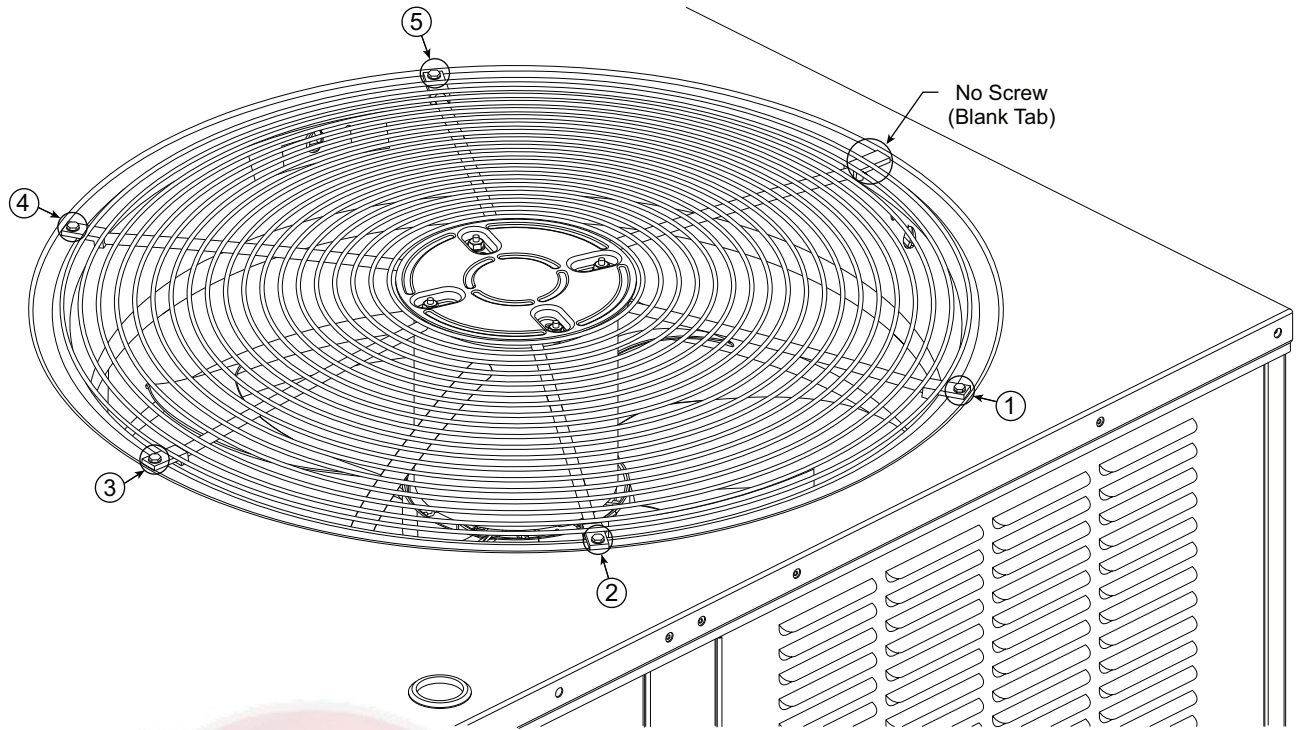
Do not install a suction-line filter drier in liquid line. A liquid-line filter drier designed for use with R-410A refrigerant is required on every unit.

**Condenser-Fan Adjustment**

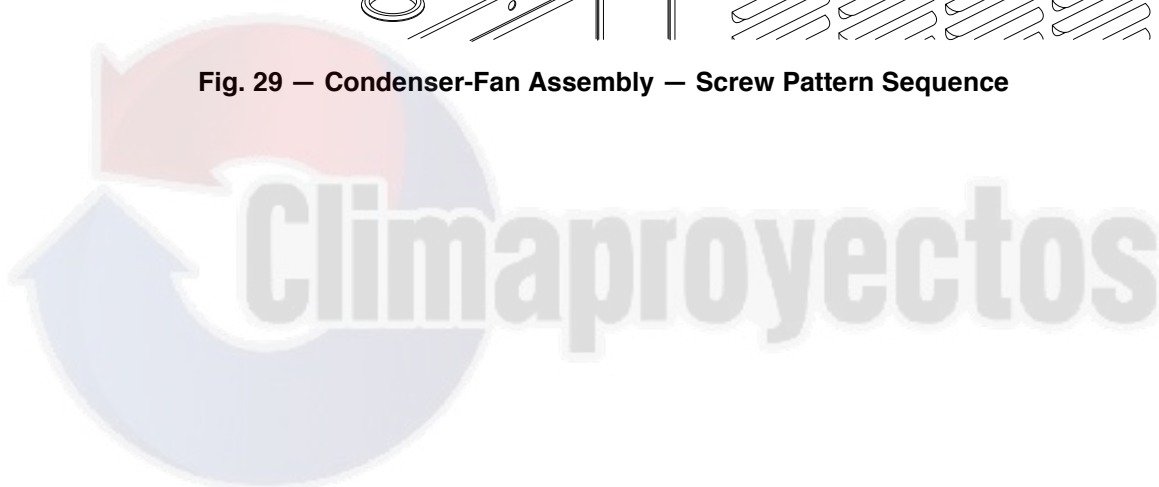
1. Shut off unit power supply. Install lockout tag.
2. Remove condenser-fan assembly (grille, motor, and fan). See Fig. 28.
3. Loosen fan hub setscrews.
4. Adjust fan height by pushing fan until it stops on the fan shaft.
5. Tighten set screw to 60 in.-lb (6.78 Nm).
6. Replace condenser-fan assembly. When replacing the condenser-fan assembly follow the screw pattern sequence shown in Fig. 29. The screws must be replaced in the sequence shown in the figure.



**Fig. 28 — Condenser Fan Adjustment**



**Fig. 29 — Condenser-Fan Assembly — Screw Pattern Sequence**



## Troubleshooting Cooling System

Refer to Table 6 for additional troubleshooting topics.

**Table 6 – Troubleshooting**

SYMPTOM	CAUSE	SOLUTION
<b>Compressor and Outdoor Fan Will Not Start</b>	Power failure.	Call power company.
	Fuse blown or circuit breaker tripped.	Replace fuse or reset circuit breaker. Determine root cause.
	Defective thermostat, contactor, transformer, control relay, or capacitor.	Replacement component.
	Insufficient line voltage.	Determine cause and correct.
	Incorrect or faulty wiring.	Check wiring diagram and rewire correctly.
	Thermostat setting too high.	Lower thermostat setting below room temperature.
	High pressure switch tripped.	See problem "Excessive head pressure."
	Low pressure switch tripped.	Check system for leaks. Repair as necessary.
<b>Compressor Will Not Start but Outdoor Fan Runs</b>	Freeze-up protection thermostat tripped.	See problem "Suction pressure too low."
	Faulty wiring or loose connections in compressor circuit.	Check wiring and repair or replace.
	Compressor motor burned out, seized, or internal overload open.	Determine cause. Replace compressor or allow enough time for internal overload to cool and reset.
	Defective run/start capacitor, overload, start relay.	Determine cause. Replace compressor or allow enough time for internal overload to cool and reset.
<b>Compressor Cycles (Other Than Normally Satisfying Thermostat)</b>	One leg of 3-phase power dead.	Replace fuse or reset circuit breaker. Determine cause.
	Refrigerant overcharge or undercharge.	Recover refrigerant, evacuate system, and recharge to nameplate.
	Defective compressor.	Replace and determine cause.
	Insufficient line voltage.	Determine cause and correct.
	Blocked outdoor coil or dirty air filter.	Determine cause and correct.
	Defective Run/Start capacitor, overload, or start relay.	Determine cause and correct.
	Defective thermostat.	Replace thermostat.
	Faulty outdoor-fan (cooling) or indoor-fan (heating) motor or capacitor.	Replace faulty part.
<b>Compressor Operates Continuously</b>	Restriction in refrigerant system.	Locate restriction and remove.
	Defective loader plug.	Determine cause and replace.
	Dirty air filter.	Replace filter.
	Unit undersized for load.	Decrease load or increase unit size.
	Thermostat set too low (cooling).	Reset thermostat.
	Low refrigerant charge.	Locate leak; repair and recharge.
<b>Compressor Makes Excessive Noise</b>	Air in system.	Recover refrigerant, evacuate system, and recharge.
	Outdoor coil dirty or restricted.	Clean coil or remove restriction.
<b>Excessive Head Pressure</b>	Compressor rotating in the wrong direction.	Reverse the 3-phase power leads as described in Start-Up.
	Dirty outside.	Replace filter.
	Dirty outdoor coil (cooling).	Clean coil.
	Refrigerant overcharged.	Recover excess refrigerant.
	Air in system.	Recover refrigerant, evacuate system, and recharge.
<b>Head Pressure Too Low</b>	Condensing air restricted or air short-cycling.	Determine cause and correct.
	Low refrigerant charge.	Check for leaks; repair and recharge.
	Compressor scroll plates defective.	Replace compressor.
<b>Excessive Suction Pressure</b>	Restriction in liquid tube.	Remove restriction.
	High heat load.	Check for source and eliminate.
	Compressor scroll plates defective.	Replace compressor.
	Refrigerant overcharge.	Recover excess refrigerant.
<b>Suction Pressure Too Low</b>	Dirty air filter (cooling).	Replace filter.
	Dirt or heavily iced outdoor coil (heating).	Clean outdoor coil. Check defrost cycle operation.
	Low refrigerant charge.	Check for leaks; repair and recharge.
	Metering device or low side restricted.	Remove source of restriction.
	Insufficient indoor airflow (cooling mode).	Increase air quantity. Check filter and replace if necessary.
	Temperature too low in conditioned area.	Reset thermostat.
	Field-installed filter drier restricted.	Replace.
	Outdoor ambient temperature below 40°F (cooling).	Install low-ambient kit.
Outdoor fan motor(s) not operating (heating).	Check fan motor operation.	



## CONVENIENCE OUTLETS

### ⚠ WARNING

#### ELECTRICAL OPERATION HAZARD

Failure to follow this warning could result in personal injury or death.

Units with convenience outlet circuits may use multiple disconnects. Check convenience outlet for power status before opening unit for service. Locate its disconnect switch, if appropriate, and open it. Lock-out and tag-out this switch, if necessary.

### Convenience Outlets

Two types of convenience outlets are offered on 50FCQ models: non-powered and unit-powered. Both types provide a 125 vac ground-fault circuit-interrupt (GFCI) duplex receptacle rated at 15A behind a hinged waterproof access cover, located on the end panel of the unit. See Fig. 30.

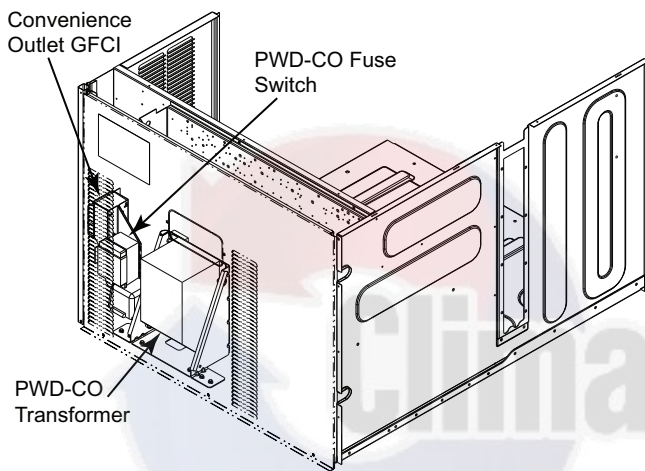


Fig. 30 — Convenience Outlet Location

### Installing Weatherproof Cover

A weatherproof while-in-use cover for the factory-installed convenience outlets is now required by UL standards. This cover cannot be factory-mounted due to its depth. The cover must be installed at unit installation. For shipment, the convenience outlet is covered with a blank cover plate.

The weatherproof cover kit is shipped in the unit's control box. The kit includes the hinged cover, a backing plate and gasket.

**NOTE: DISCONNECT ALL POWER TO UNIT AND CONVENIENCE OUTLET.** Use approved lockout/tag-out procedures.

1. Remove the blank cover plate at the convenience outlet; discard the blank cover.
2. Loosen the 2 screws at the GFCI duplex outlet, until approximately 1/2 in. (13 mm) under screw heads is exposed.

3. Press the gasket over the screw heads. Slip the backing plate over the screw heads at the keyhole slots and align with the gasket; tighten the 2 screws until snug (do not over-tighten).
4. Mount the weatherproof cover to the backing plate as shown in Fig. 31.
5. Remove 2 slot fillers in the bottom of the cover to permit service tool cords to exit the cover.
6. Check cover installation for full closing and latching.

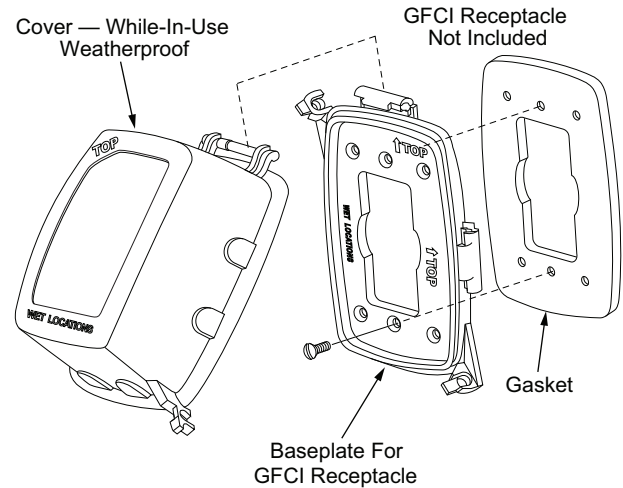


Fig. 31 — Weatherproof Cover Installation

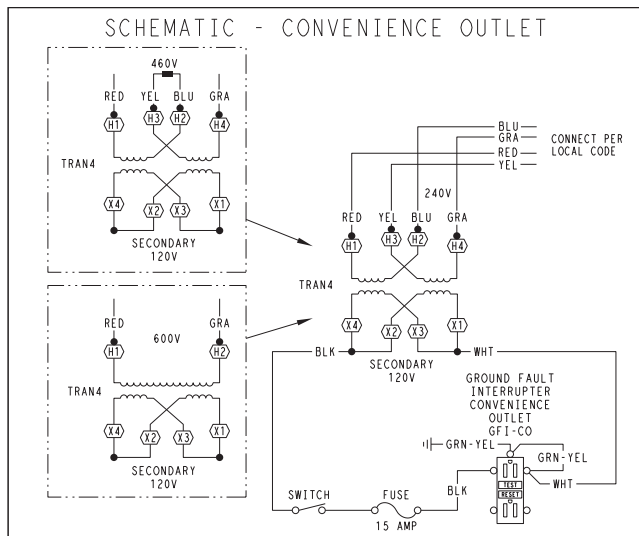
### Non-Powered Type

This type requires the field installation of a general-purpose 125-v 15A circuit powered from a source elsewhere in the building. Observe national and local codes when selecting wire size, fuse or breaker requirements and disconnect switch size and location. Route 125-v power supply conductors into the bottom of the utility box containing the duplex receptacle.

### Unit-Powered Type

A unit-mounted transformer is factory-installed to step-down the main power supply voltage to the unit to 115-v at the duplex receptacle. This option also includes a manual switch with fuse, located in a utility box and mounted on a bracket behind the convenience outlet; access is through the unit's control box access panel. See Fig. 30.

The primary leads to the convenience outlet transformer are not factory-connected. Selection of primary power source is a customer option. If local codes permit, the transformer primary leads can be connected at the line-side terminals on a unit-mounted non-fused disconnect or Heating, Air Conditioning and Refrigeration (HACR) breaker switch; this will provide service power to the unit when the unit disconnect switch or HACR switch is open. Other connection methods will result in the convenience outlet circuit being de-energized when the unit disconnect or HACR switch is open. See Fig. 32.



UNIT VOLTAGE	CONNECT AS	PRIMARY CONNECTIONS	TRANSFORMER TERMINALS
208, 230	240	L1: RED + YEL L2: BLU + GRA	H1 + H3 H2 + H4
460	480	L1: RED L2: Splice BLU + YEL L3: GRA	H1 H2 + H3 H4
575	600	L1: RED L2: GRA	H1 H2

Fig. 32 — Powered Convenience Outlet Wiring

### Duty Cycle

The unit-powered convenience outlet has a duty cycle limitation. The transformer is intended to provide power on an intermittent basis for service tools, lamps, etc; it is not intended to provide 15A loading for continuous duty loads (such as electric heaters for overnight use). Observe a 50% limit on circuit loading above 8A (i.e., limit loads exceeding 8A to 30 minutes of operation every hour).

### Maintenance

Periodically test the GFCI receptacle by pressing the TEST button on the face of the receptacle. This should cause the internal circuit of the receptacle to trip and open the receptacle. Check for proper grounding wires and power line phasing if the GFCI receptacle does not trip as required. Press the RESET button to clear the tripped condition.

### Fuse on Powered Type

The factory fuse is a Bussmann™<sup>1</sup> Fusetron™<sup>1</sup> T-15, non-renewable screw-in (Edison base) type plug fuse.

1. Third-party trademarks and logos are the property of their respective owners.

### USING UNIT-MOUNTED CONVENIENCE OUTLETS

Units with unit-mounted convenience outlet circuits will often require that 2 disconnects be opened to de-energize all power to the unit. Treat all units as electrically energized until the convenience outlet power is also checked and de-energization is confirmed. Observe National Electrical Code Article 210, Branch Circuits, for use of convenience outlets.

### COMMERCIAL DEFROST CONTROL

On 50FCQ units equipped with electro-mechanical controls or the optional factory-installed RTU Open controller, the Defrost Control Board (DFB) coordinates thermostat demands for supply fan control, 1 or 2 stage cooling, 2 stage heating, emergency heating and defrost control with unit operating sequences. The DFB also provides an indoor fan off delay feature (user selectable). See Fig. 33 for board arrangement.

The DFB is located in the main control box of the 50FCQ unit (see Fig. 34). All connections are factory-made through harnesses to the UCB (unit control board) to the ECM (direct-drive motor), reversing valve solenoids, and to defrost thermostats. Refer to Table 7 for details of DFB Inputs and Outputs.

NOTE: The Defrost Control Board is not used on units equipped with the factory-installed SystemVu™ controller option.

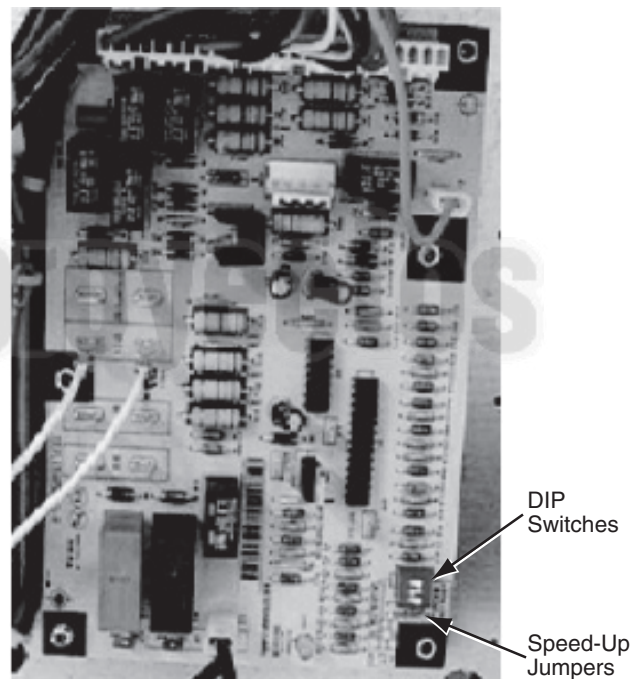
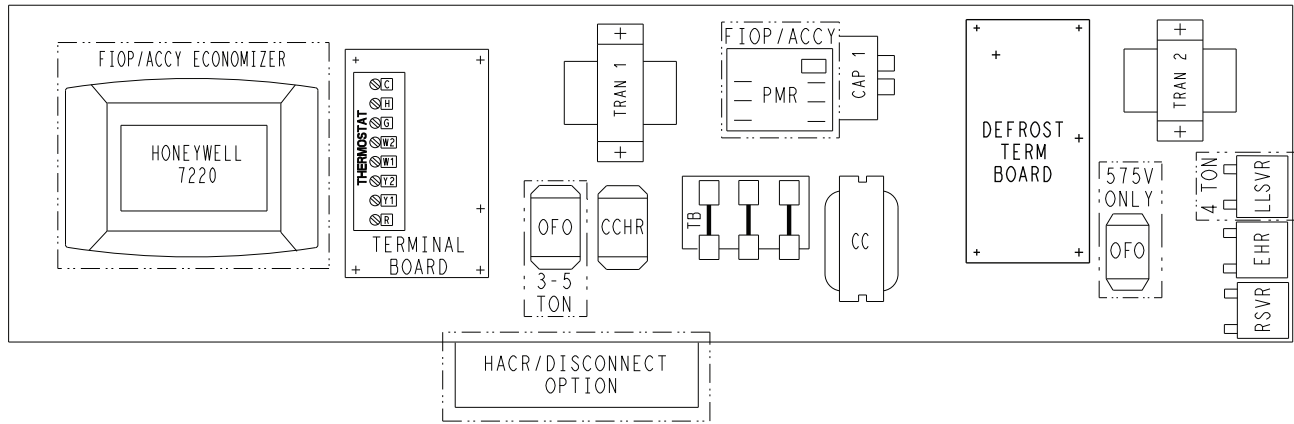


Fig. 33 — Defrost Control Board Arrangement



**Fig. 34 – Defrost Control Board Location – 50FCQ\*04-07 Electro-Mechanical Units**

**Table 7 – 50FCQ Defrost Board I/O and Jumper Configurations<sup>a,b</sup>**

POINT NAME	TYPE OF I/O	CONNECTION PIN NUMBER	UNIT CONNECTION	NOTE
<b>INPUTS</b>				
G Fan	DI, 24 vac	P2-3	CTB-G	
Y1 Cool 1	DI, 24 vac	P2-5	CTB-Y1	
Y2 Cool 2	DI, 24 vac	P2-4	CTB-Y2	
W1 Heat 1	DI, 24 vac	P2-7	CTB-W1	
W2 Heat 2	DI, 24 vac	P2-6	CTB-W2	
R Power	24 vac	P3-1	CONTL BRD-8	
C Common	24 vac	P3-2	CONTL BRD-4	
DFT 1	DI, 24 vac	DFT-1 to DFT-1	—	
DFT 2	DI, 24 vac	DFT-2 to DFT-2	—	
<b>OUTPUTS</b>				
IFO Fan On	DO, 24 vac	P3-9	REHEAT/HP-2	
OF OD Fan On	DO, 24 vac	OF	OFR	
RVS1	DO, 24 vac	P3-7 to P3-5	—	Energize in COOL
RVS2	DO, 24 vac	P3-6 to P3-4	—	Energize in COOL
COMP 1	DO, 24 vac	P3-10	FPT1-REHEAT/HP-6	
COMP 2	DO, 24 vac	P3-8	FPT2-REHEAT/HP-8	
HEAT 2	DO, 24 vac	E-HEAT	TB4-1	
COM	24 vac	P3-3	TB4-3	
<b>CONFIGURATION</b>				
Select Jumper	24 vac	P1-1	—	
<b>SPEED-UP CONFIGURATION</b>				
Speed-Up Jumper	—	JMP17	—	
Speed-Up Jumper	—	JMP18	—	

NOTE(S):

- Jumper for 1-3 seconds: Factory Test — The defrost interval timing is reduced by a factor of 0.1 seconds/minute based on the positions of DIP switches SW1 and SW2 (i.e., 90 minutes will be reduced to 9 seconds).
- Jumper for 5-20 seconds: Forced Defrost—Defrost runs for 30 seconds if DFT2 is open.

## Reversing Valve Control

The DFB has 2 outputs for unit reversing valve control. Operation of the reversing valves is based on internal logic; this application does not use an “O” or “B” signal to determine reversing valve position. Reversing valves are energized during the cooling stages and the defrost cycle and de-energized during heating cycles. Once energized at the start of a cooling stage, the reversing valve will remain energized until the next heating cycle demand is received. Once de-energized at the start of a Heating cycle, the reversing valves will remain de-energized until the next cooling stage is initiated.

## Compressor Control

The DFB receives inputs indicating Stage 1 Cooling, Stage 2 Cooling and Stage 1 Heating from the space thermostat or unit control system (SystemVu™ controller or RTU Open controller); it

generates commands to start compressors with or without reversing valve operation to produce Stage 1 Cooling (one compressor runs), Stage 2 Cooling (both compressors run) or Stage 1 Heating (both compressors run).

## Auxiliary (Electric) Heat control

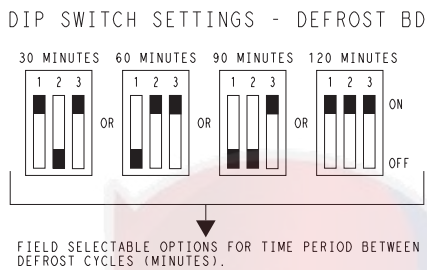
The 50FCQ unit can be equipped with one or 2 auxiliary electric heaters, to provide a second stage of heating. The DFB will energize this Heating System for a Stage 2 Heating Command (heaters operate concurrently with compressor(s) in the Stage 1 Heating cycle), for an Emergency Heating sequence (compressors are off and only the electric heaters are energized) and also during the Defrost cycle (to eliminate a “cold blow” condition in the space).

## Defrost

The defrost control mode is a time/temperature sequence. There are 2 time components: The continuous run period and the test/defrost cycle period. The temperature component is provided by Defrost Thermostat 1 and 2 (DFT1 and DFT2) mounted on the outdoor coil.

The continuous run period is a fixed time period between the end of the last defrost cycle (or start of the current Heating cycle) during which no defrost will be permitted. This period can be set at 30, 60, 90 or 120 minutes by changing the positions of DIP switches SW1 and SW2 (see Fig. 35 and Table 8). The default run period is 30 minutes.

Shorting the jumpers for a period of 5 to 20 seconds bypasses the remaining continuous run period and places the unit in a Forced Defrost mode. If the controlling DFT is closed when this mode is initiated, the unit will complete a normal defrost period that will terminate when the controlling DFT opens or the 10 minute defrost cycle limit is reached. If the controlling DFT is open when this mode is initiated, the Defrost cycle will run for 30 seconds. Both modes end at the end of the Defrost cycle.

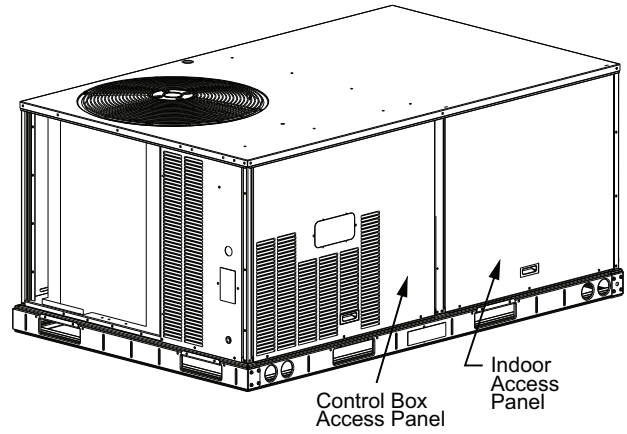


**Fig. 35 — DIP Switch Settings — Defrost Board**

## ELECTRIC HEATERS

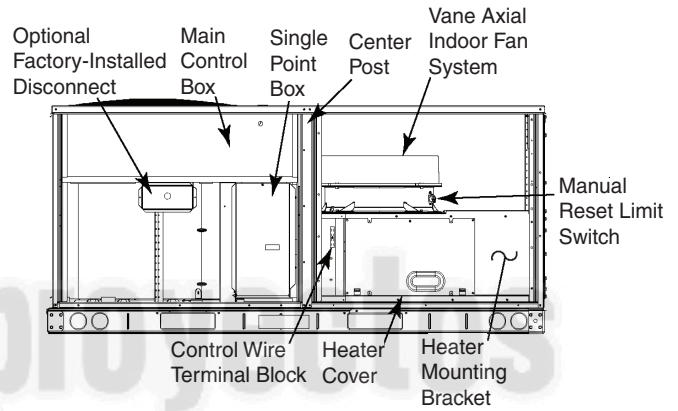
The 50FCQ units can be equipped with field-installed accessory electric heaters. The heaters are modular in design, with heater frames holding open coil resistance wires strung through ceramic insulators and control contactor(s), using a combination of 24-v control side break/auto-reset or line-break/auto-reset limit switches and a pilot-circuit/manual reset limit switch to protect the unit against over-temperature situations. All 50FCQ Model electric heaters are one module containing either one or 2 banks of electric heat coils.

Heater modules are installed in the compartment below the indoor (supply) fan outlet. Access is through the indoor access panel. Heater modules slide into the compartment on tracks along the bottom of the heater opening. See Fig. 36-38.

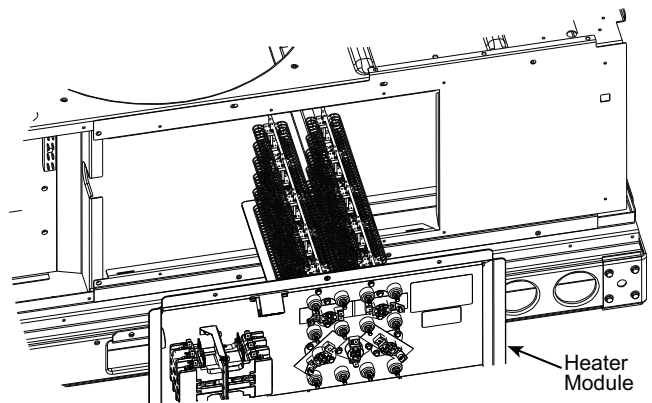


**Fig. 36 — Typical Access Panel Location**

Not all available heater modules can be used in every unit. Use only those heater modules that are UL listed for use in a specific size unit. Refer to the label on the unit cabinet regarding approved heaters.



**Fig. 37 — Typical Component Location**



**Fig. 38 — Typical Module Installation**

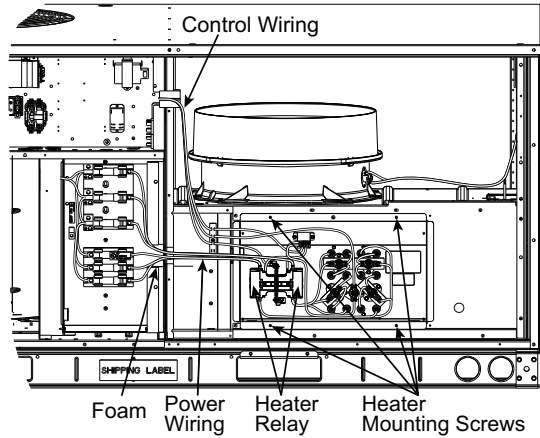
**Table 8 — DIP Switch Positions**

	1	2		1	2		1	2		1	2	3		
1	•		1		•	1			1	•	•	1	•	On
0		•	0	•		0	•	•	0			0		Off
	30 minutes (factory default)			60 minutes			90 minutes			120 minutes			Fan Delay	



## Single Point Boxes and Supplementary Fuses

When the unit MOCP device value exceeds 60A, unit-mounted supplementary fuses are required for each heater circuit. These fuses are included in accessory single point boxes, with power distribution and fuse blocks. The single point box will be installed directly under the unit control box, just to the left of the partition separating the indoor section (with electric heaters) from the outdoor section. The single point box has a hinged access cover. See Fig. 39.



**Fig. 39 — Typical Single Point Installation**

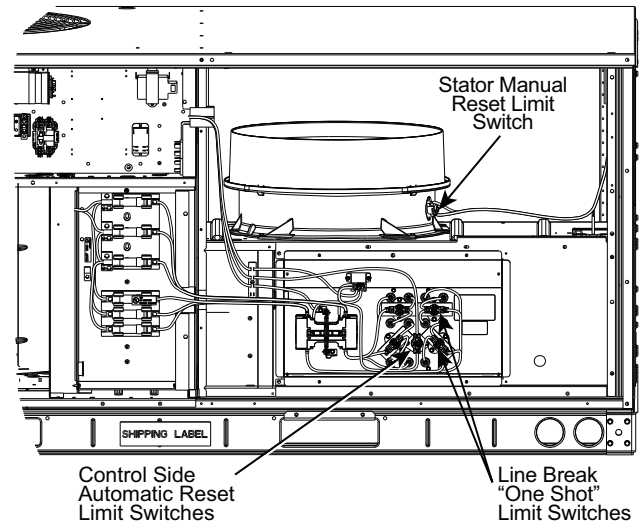
On 50FCQ units, all fuses are 60A. Single point boxes containing fuses for 208/230-v applications use UL Class RK5 250-v fuses (Bussmann™<sup>1</sup> FRNR 60 or Ferraz Shawmut TR 60R). Single point boxes for 460-v and 575-v applications use UL Class T 600-v fuses (Bussmann™<sup>1</sup> JJS 60 or Ferraz Shawmut A6T 60). (Note that all heaters are qualified for use with a 60A fuse, regardless of actual heater ampacity, so only 60A fuses are necessary.)

## Safety Devices

CRHEATERS323A00-341A00 electric heater applications use a combination of 24-v control side break/auto-reset, line-break/non-resettable “one shot” limit switches and a fan stator/manual reset limit switch to protect the unit against over-temperature situations.

Line-break/auto-reset limit switches, 24-v control side break/auto-reset and line-break/non-resettable “one shot” limit switches are mounted on the base plate of each heater module. See Fig. 40. These are accessed through the indoor access panel. Remove the switch by removing 2 screws into the base plate and extracting the existing switch.

Fan stator/manual reset limit switch is located in the side plate of the indoor (supply) fan housing. See Fig. 40.



**Fig. 40 — Typical Location of Heater Limit Switches (3-phase heater shown)**

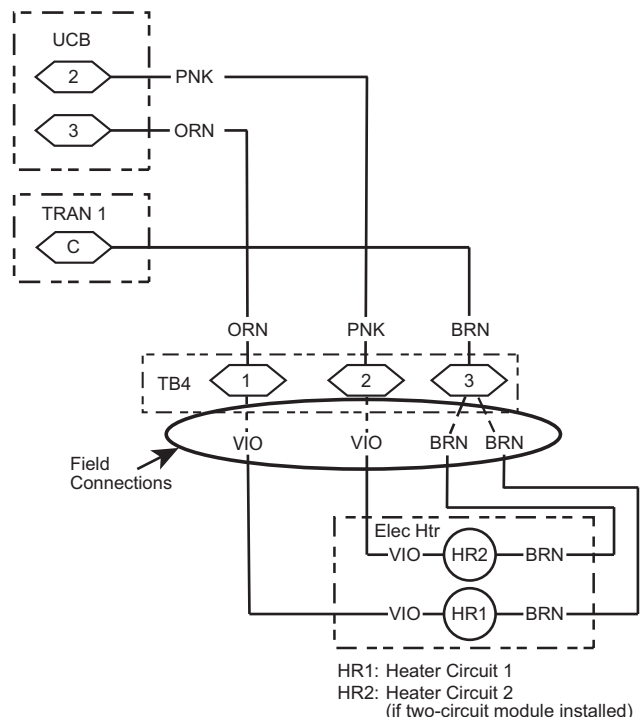
## Completing Heater Installation

### FIELD POWER CONNECTIONS

Tap conductors must be installed between the base unit’s field power connection lugs and the single point box (with or without fuses). See Fig. 41. Refer to unit wiring schematic. Use copper wire only. For connection using the single point box without fuses, connect the field power supply conductors to the heater power leads and the field-supplied tap conductors inside the single point box. Use UL-approved pressure connectors (field-supplied) for these splice joints.

### LOW-VOLTAGE CONTROL CONNECTIONS

Pull the low-voltage control leads from the heater module(s) — ORN, VIO and BRN — to the 4-pole terminal board TB4 located on the heater bulkhead to the left of heater 1. Connect the ORN lead to terminal TB4-1. Connect the VIO lead to terminal TB4-2. Connect the BRN lead to terminal TB4-3. See Fig. 41.



**Fig. 41 — Accessory Electric Heater Control Connections**

1. Third-party trademarks and logos are the property of their respective owners.

## SMOKE DETECTORS

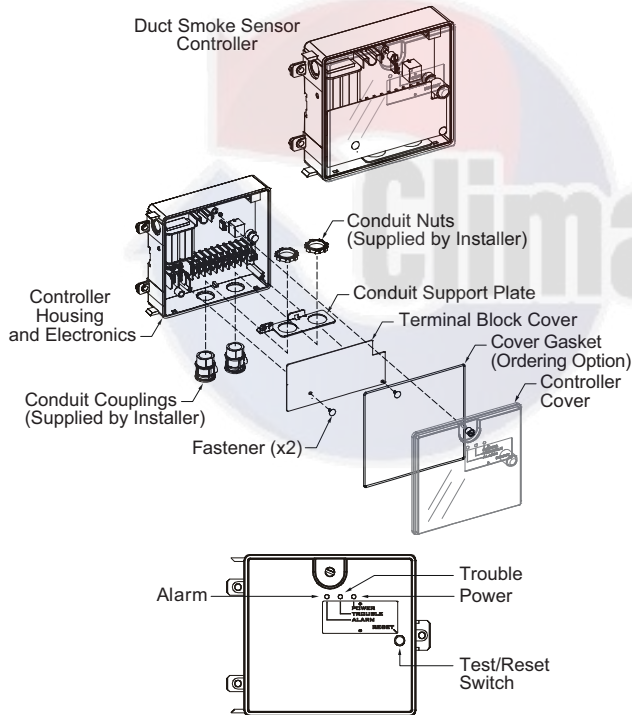
Smoke detectors are available as factory-installed options on 50FCQ models. Smoke detectors may be specified for supply air only, for return air without or with economizer, or in combination of supply air and return air. Return air smoke detectors are arranged for vertical return configurations only. All components necessary for operation are factory-provided and mounted. The unit is factory-configured for immediate smoke detector shutdown operation; additional wiring or modifications to unit terminal board may be necessary to complete the unit and smoke detector configuration to meet project requirements.

### System

The smoke detector system consists of a 4-wire controller and one or 2 sensors. Its primary function is to shut down the rooftop unit in order to prevent smoke from circulating throughout the building. It is not to be used as a life saving device.

### Controller

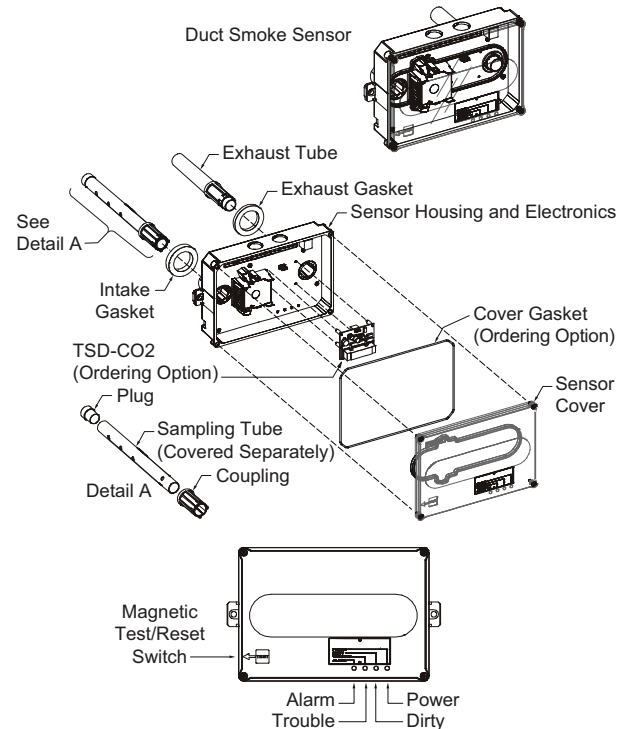
The controller (see Fig. 42) includes a controller housing, a printed circuit board, and a clear plastic cover. The controller can be connected to one or 2 compatible duct smoke sensors. The clear plastic cover is secured to the housing with a single captive screw for easy access to the wiring terminals. The controller has 3 LEDs (for Power, Trouble, and Alarm) and a manual test/reset button (on the cover face).



**Fig. 42 – Controller Assembly**

### Smoke Detector Sensor

The smoke detector sensor (see Fig. 43) includes a plastic housing, a printed circuit board, a clear plastic cover, a sampling tube inlet, and an exhaust tube. The sampling tube (when used) and exhaust tube are attached during installation. The sampling tube varies in length depending on the size of the rooftop unit. The clear plastic cover permits visual inspections without having to disassemble the sensor. The cover attaches to the sensor housing using 4 captive screws and forms an airtight chamber around the sensing electronics. Each sensor includes a harness with an RJ45 terminal for connecting to the controller. Each sensor has 4 LEDs (for Power, Trouble, Alarm, and Dirty) and a manual test/reset button (on the left-side of the housing).



**Fig. 43 – Smoke Detector Sensor**

Air is introduced to the duct smoke detector sensor's sensing chamber through a sampling tube that extends into the HVAC duct and is directed back into the ventilation system through a (shorter) exhaust tube.

The difference in air pressure between the 2 tubes pulls the sampled air through the sensing chamber. When a sufficient amount of smoke is detected in the sensing chamber, the sensor signals an alarm state and the controller automatically takes the appropriate action to shut down fans and blowers, change over air handling systems, notify the fire alarm control panel, etc.

The sensor uses a process called differential sensing to prevent gradual environmental changes from triggering false alarms. A rapid change in environmental conditions, such as smoke from a fire, causes the sensor to signal an alarm state but dust and debris accumulated over time does not.

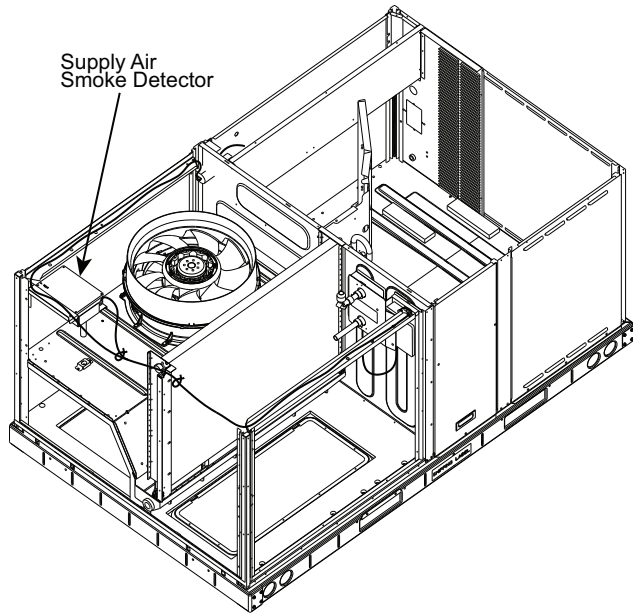
The difference in air pressure between the 2 tubes pulls the sampled air through the sensing chamber. When a sufficient amount of smoke is detected in the sensing chamber, the sensor signals an alarm state and the controller automatically takes the appropriate action to shut down fans and blowers, change over air handling systems, notify the fire alarm control panel, etc.

For installations using 2 sensors, the duct smoke detector does not differentiate which sensor signals an alarm or trouble condition.

### Smoke Detector Locations

#### SUPPLY AIR

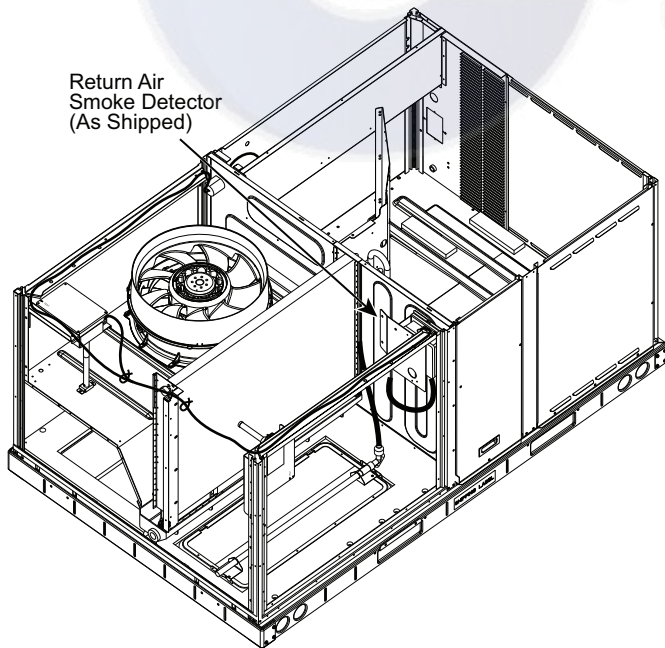
The supply air smoke detector sensor is located to the right of the unit's indoor (supply) fan. See Fig. 44. Access is through the fan access panel. The sampling tube inlet extends through the fan deck (into a high pressure area). The controller is located on a bracket to the right of the return filter, accessed through the lift-off filter panel.



**Fig. 44 — Typical Supply Air Smoke Detector Sensor Location**

**RETURN AIR SMOKE DETECTOR SENSOR WITHOUT ECONOMIZER**

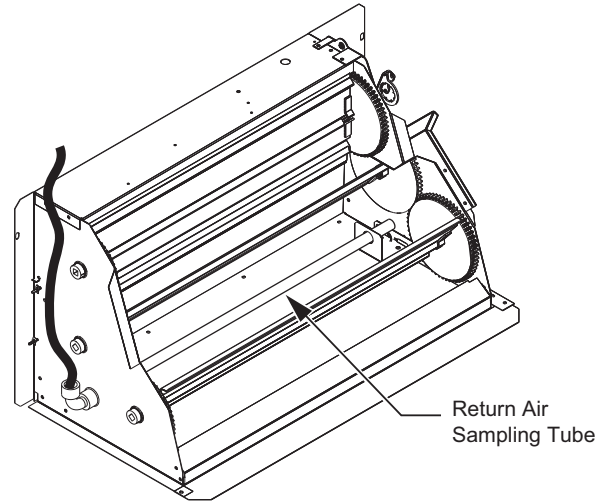
The sampling tube is located across the return air opening on the unit basepan. See Fig. 45. The holes in the sampling tube face downward, into the return air stream. The sampling tube is connected through tubing to the return air sensor that is mounted on a bracket high on the partition between return filter and controller location. The sensor is shipped in a flat-mounting location. Installation requires that this sensor be relocated to its operating location and the tubing to the sampling tube be connected. See installation steps.



**Fig. 45 — Typical Return Air Smoke Detector Location**

**RETURN AIR SMOKE DETECTOR SENSOR WITH ECONOMIZER**

The sampling tube is inserted through the side plates of the economizer housing, placing it across the return air opening on the unit basepan. See Fig. 46. The holes in the sampling tube face downward, into the return air stream. The sampling tube is connected using tubing to the return air sensor mounted on a bracket high on the partition between return filter and controller location. The sensor is shipped in a flat-mounting location. Installation requires the sensor be relocated to its operating location and the tubing to the sampling tube be connected. See installation steps below.

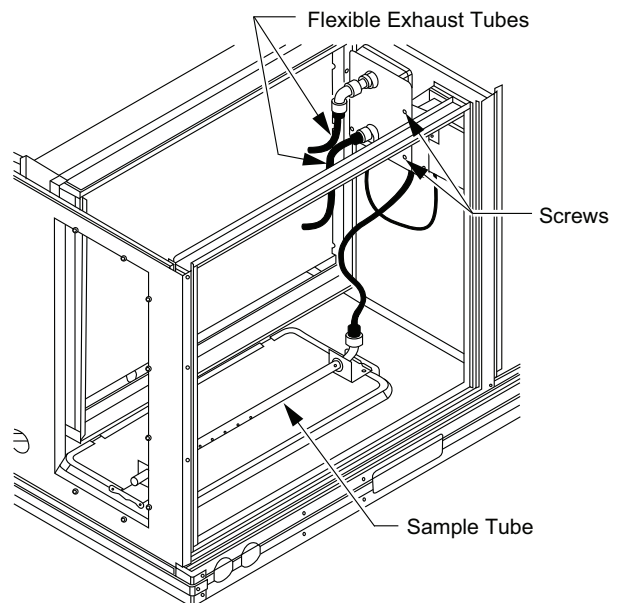


**Fig. 46 — Return Air Sampling Tube Location (View reoriented to show opposite side for clarity.)**

**Completing Installation of Return Air Smoke Detector**

Use the following steps to complete the installation of the return air smoke detector.

1. Unscrew the 2 screws holding the return air sensor detector plate. See Fig. 47. Save the screws.

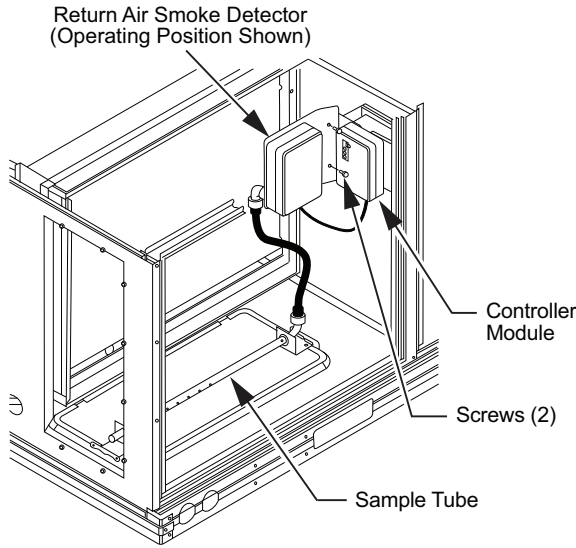


**Fig. 47 — Return Air Smoke Detector Shipping Position**

2. Remove the return air smoke sensor module and its detector plate.



3. Rotate the detector plate so the sensor is facing outwards and the sampling tube connection is on the bottom. See Fig. 48.



**Fig. 48 — Return Air Smoke Detector Operating Position**

4. Screw the sensor and detector plate into its operating position using screws from Step 1. Ensure the sampling tube connection is on the bottom and the exhaust tube is on the top.
5. Connect the flexible tube on the sampling inlet to the sampling tube on the basepan.
6. For units with an economizer, the sampling tube is integrated into the economizer housing but connecting the flexible tubing to the sampling tube is the same.

## FIOP Smoke Detector Wiring and Response

### ALL UNITS

The FIOP smoke detector is configured to automatically shut down all unit operations when a smoke condition is detected. See Fig. 49, Smoke Detector Wiring.

### HIGHLIGHT A

Smoke detector NC contact set will open on smoke alarm condition, de-energizing the ORN conductor.

### HIGHLIGHT B

24-v power signal using the ORN lead is removed at the smoke detector input on UCB; all unit operations cease immediately.

### RTU OPEN CONTROLS

Unit operating functions (fan, cooling and heating) are terminated as described above. In addition:

### HIGHLIGHT C

On smoke alarm condition, the smoke detector NO Alarm contact will close, supplying 24-v power to GRA conductor.

### HIGHLIGHT D

WHT lead at Smoke Alarm input on UCB provides 24-v signal to FIOP DDC control.

### RTU OPEN

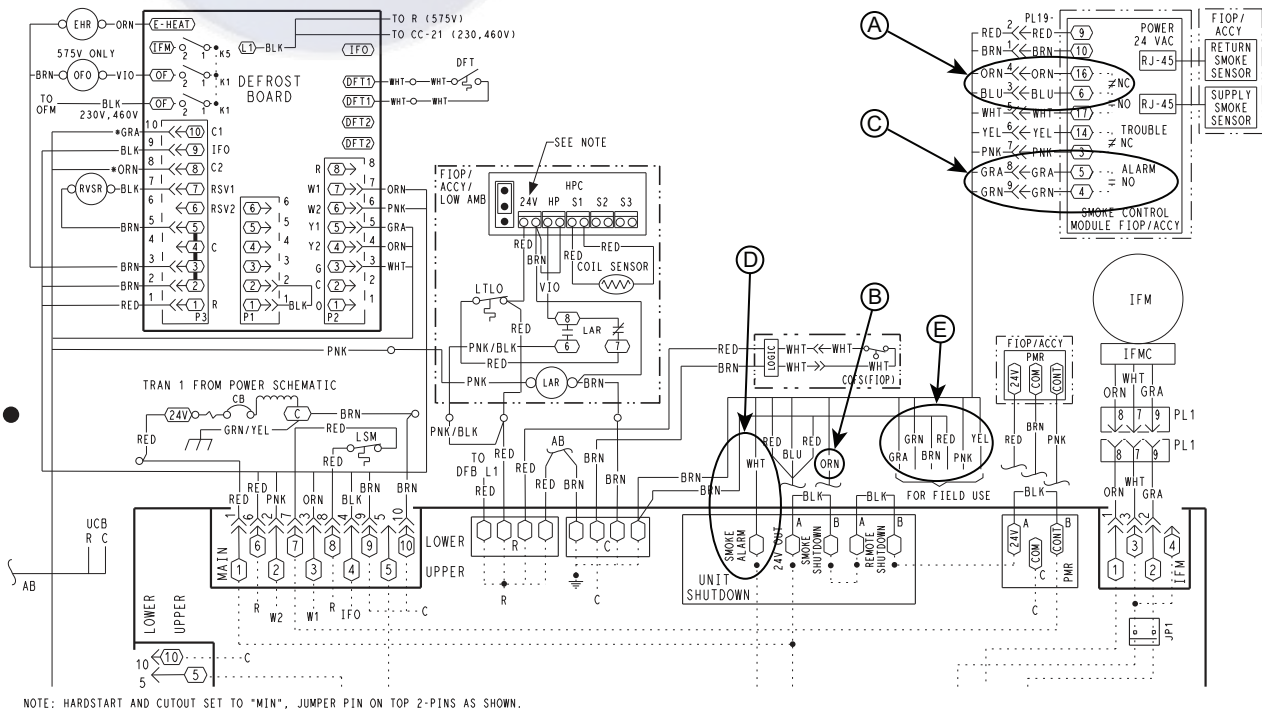
The 24-v signal is conveyed to RTU Open-J1-10 input terminal. This signal initiates the FSD sequence by the RTU Open control. FSD status is reported to connected BAS network.

### USING REMOTE LOGIC

Six conductors are provided for field use (see Highlight E) for additional annunciation functions.

### ADDITIONAL APPLICATION DATA

Refer to the application data document “Factory Installed Smoke Detectors for Small and Medium Rooftop Units 2 to 25 Tons” for discussions on additional control features of these smoke detectors including multiple unit coordination.



NOTE: HARDSTART AND CUTOUT SET TO "MIN", JUMPER PIN ON TOP 2-PINS AS SHOWN.

**Fig. 49 — Typical Smoke Detector System Wiring**



## SENSOR AND CONTROLLER TESTS

### Sensor Alarm Test

The sensor alarm test checks a sensor's ability to signal an alarm state. This test requires use of a field provided SD-MAG test magnet.

**IMPORTANT:** Failure to follow this ALERT can result in an unnecessary evacuation of the facility.

This test places the duct detector into the alarm state. Unless part of the test, disconnect all auxiliary equipment from the controller before performing the test. If the duct detector is connected to a fire alarm system, notify the proper authorities before performing the test.

#### SENSOR ALARM TEST PROCEDURE

1. Hold the test magnet where indicated on the side of the sensor housing for 7 seconds.
2. Verify that the sensor's Alarm LED turns on.
3. Reset the sensor by holding the test magnet against the sensor housing for 2 seconds.
4. Verify that the sensor's Alarm LED turns off.

### Controller Alarm Test

The controller alarm test checks the controller's ability to initiate and indicate an alarm state.

#### CONTROLLER ALARM TEST PROCEDURE

1. Press the controller's test/reset switch for 7 seconds.
2. Verify that the controller's Alarm LED turns on.
3. Reset the sensor by pressing the test/reset switch for 2 seconds.
4. Verify that the controller's Alarm LED turns off.

**IMPORTANT:** Failure to follow this ALERT can result in an unnecessary evacuation of the facility.

This test places the duct detector into the alarm state. Unless part of the test, disconnect all auxiliary equipment from the controller before performing the test. If the duct detector is connected to a fire alarm system, notify the proper authorities before performing the test.

### Dirty Controller Test

The dirty controller test checks the controller's ability to initiate a dirty sensor test and indicate its results.

**IMPORTANT:** Failure to follow this ALERT can result in an unnecessary evacuation of the facility.

Pressing the controller's test/reset switch for longer than 7 seconds will put the duct detector into the alarm state and activate all automatic alarm responses.

#### DIRTY CONTROLLER TEST PROCEDURE

1. Press the controller's test/reset switch for 2 seconds.
2. Verify that the controller's Trouble LED flashes.

### Dirty Sensor Test

The dirty sensor test provides an indication of the sensor's ability to compensate for gradual environmental changes. A sensor that can no longer compensate for environmental changes is considered 100% dirty and requires cleaning or replacing. A field provided SD-MAG test magnet must be used to initiate a sensor dirty test. The sensor's Dirty LED indicates the results of the dirty test as shown in Table 9.

**IMPORTANT:** Failure to follow this ALERT can result in an unnecessary evacuation of the facility.

Holding the test magnet against the sensor housing for more than 7 seconds will put the duct detector into the alarm state and activate all automatic alarm responses.

**Table 9 – Dirty LED Test**

FLASHES	DESCRIPTION
1	0-25% dirty (Typical of a newly installed detector)
2	25-50% dirty
3	51-75% dirty
4	76-99% dirty

#### DIRTY SENSOR TEST PROCEDURE

1. Hold the test magnet where indicated on the side of the sensor housing for 2 seconds.
2. Verify that the sensor's Dirty LED flashes.

**IMPORTANT:** Failure to follow this ALERT can result in an unnecessary evacuation of the facility.

Changing the dirty sensor test operation will put the detector into the alarm state and activate all automatic alarm responses. Before changing dirty sensor test operation, disconnect all auxiliary equipment from the controller and notify the proper authorities if connected to a fire alarm system.

### Changing the Dirty Sensor Test

By default, sensor dirty test results are indicated by:

- The sensor's Dirty LED flashing.
- The controller's Trouble LED flashing.
- The controller's supervision relay contacts toggle.

The operation of a sensor's dirty test can be changed so that the controller's supervision relay is not used to indicate test results. When 2 detectors are connected to a controller, sensor dirty test operation on both sensors must be configured to operate in the same manner.

#### TO CONFIGURE THE DIRTY SENSOR TEST OPERATION

1. Hold the test magnet where indicated on the side of the sensor housing until the sensor's Alarm LED turns on and its Dirty LED flashes twice (approximately 60 seconds).
2. Reset the sensor by removing the test magnet then holding it against the sensor housing again until the sensor's Alarm LED turns off (approximately 2 seconds).

### Remote Station Test

The remote station alarm test checks a test/reset station's ability to initiate and indicate an alarm state.

**IMPORTANT:** Failure to follow this ALERT can result in an unnecessary evacuation of the facility.

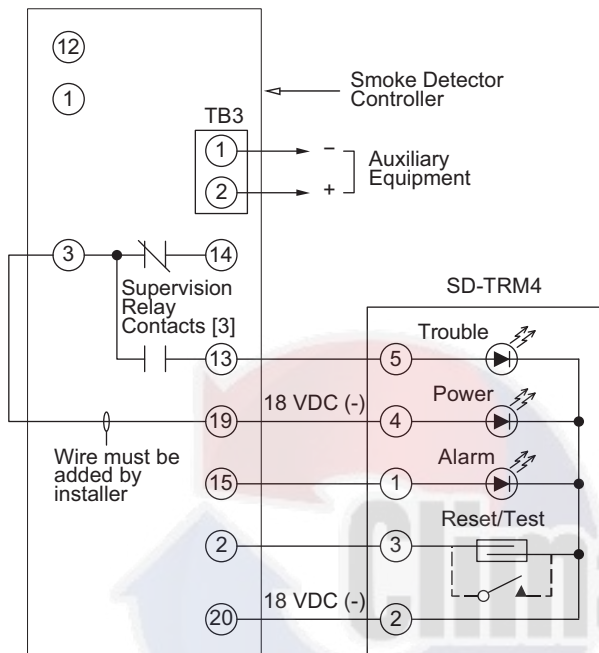
This test places the duct detector into the alarm state. Unless part of the test, disconnect all auxiliary equipment from the controller before performing the test. If the duct detector is connected to a fire alarm system, notify the proper authorities before performing the test.

## SD-TRM4 Remote Alarm Test Procedure

1. Hold the test magnet to the target area for 7 seconds.
2. Verify that the test/reset station's Alarm LED turns on.
3. Reset the sensor by holding the test magnet to the target area for 2 seconds.
4. Verify that the test/reset station's Alarm LED turns off.

## Remote Test/Reset Station Dirty Sensor Test

The test/reset station dirty sensor test checks the test/reset station's ability to initiate a sensor dirty test and indicate the results. It must be wired to the controller as shown in Fig. 50 and configured to operate the controller's supervision relay. For more information, see "Dirty Sensor Test" on page 29.



**Fig. 50 — Remote Test/Reset Station Connections**

**IMPORTANT:** Failure to follow this ALERT can result in an unnecessary evacuation of the facility. If the test/reset station's key switch is left in the RESET/TEST position for longer than 7 seconds, the detector will automatically go into the alarm state and activate all automatic alarm responses.

**IMPORTANT:** Failure to follow this ALERT can result in an unnecessary evacuation of the facility. Holding the test magnet to the target area for longer than 7 seconds will put the detector into the alarm state and activate all automatic alarm responses.

## Dirty Sensor Test Using an SD-TRM4

1. Hold the test magnet where indicated on the side of the sensor housing for 2 seconds.
2. Verify that the test/reset station's Trouble LED flashes.

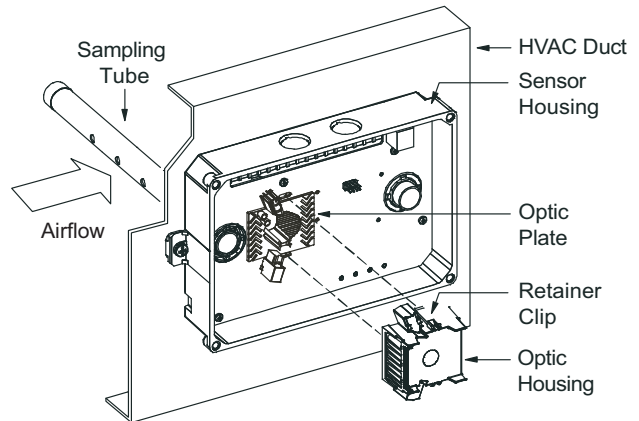
## Detector Cleaning

### CLEANING THE SMOKE DETECTOR

Clean the duct smoke sensor when the Dirty LED is flashing continuously or sooner, if conditions warrant.

**IMPORTANT: OPERATIONAL TEST ALERT**  
Failure to follow this ALERT can result in an unnecessary evacuation of the facility. If the smoke detector is connected to a fire alarm system, first notify the proper authorities that the detector is undergoing maintenance then disable the relevant circuit to avoid generating a false alarm.

1. Disconnect power from the duct detector then remove the sensor's cover. See Fig. 51.



**Fig. 51 — Sensor Cleaning Diagram**

2. Using a vacuum cleaner, clean compressed air, or a soft bristle brush, remove loose dirt and debris from inside the sensor housing and cover. Use isopropyl alcohol and a lint-free cloth to remove dirt and other contaminants from the gasket on the sensor's cover.
3. Squeeze the retainer clips on both sides of the optic housing.
4. Lift the housing away from the printed circuit board.
5. Gently remove dirt and debris from around the optic plate and inside the optic housing.
6. Replace the optic housing and sensor cover.
7. Connect power to the duct detector then perform a sensor alarm test.

## Indicators

### NORMAL STATE

The smoke detector operates in the normal state in the absence of any trouble conditions and when its sensing chamber is free of smoke. In the normal state, the Power LED on both the sensor and the controller are on and all other LEDs are off.

### ALARM STATE

The smoke detector enters the alarm state when the amount of smoke particulate in the sensor's sensing chamber exceeds the alarm threshold value. (See Table 10.) Upon entering the alarm state:

- The sensor's Alarm LED and the controller's Alarm LED turn on.
- The contacts on the controller's 2 auxiliary relays switch positions.
- The contacts on the controller's alarm initiation relay close.
- The controller's remote Alarm LED output is activated (turned on).
- The controller's high impedance multiple fan shutdown control line is pulled to ground.

**Table 10 – Detector Indicators**

CONTROL OR INDICATOR	DESCRIPTION
<b>Magnetic test/reset switch</b>	Resets the sensor when it is in the alarm or trouble state. Activates or tests the sensor when it is in the normal state.
<b>Alarm LED</b>	Indicates the sensor is in the alarm state.
<b>Trouble LED</b>	Indicates the sensor is in the trouble state.
<b>Dirty LED</b>	Indicates the amount of environmental compensation used by the sensor (flashing continuously = 100%).
<b>Power LED</b>	Indicates the sensor is energized.

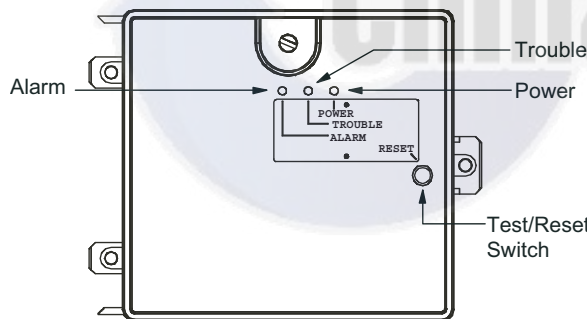
**TROUBLE STATE**

The SuperDuct™<sup>TM1</sup> duct smoke detector enters the trouble state under the following conditions:

- A sensor’s cover is removed and 20 minutes pass before it is properly secured.
- A sensor’s environmental compensation limit is reached (100% dirty).
- A wiring fault between a sensor and the controller is detected.
- An internal sensor fault is detected.

Upon entering the trouble state:

- The contacts on the controller’s supervisory relay switch positions. (See Fig. 52.)
- If a sensor trouble, the sensor’s Trouble LED and the controller’s Trouble LED turn on.
- If 100% dirty, the sensor’s Dirty LED turns on and the controller’s Trouble LED flashes continuously.
- If a wiring fault between a sensor and the controller, the controller’s Trouble LED turns on but not the sensor’s.



**Fig. 52 – Controller Assembly**

**NOTE:** All troubles are latched by the duct smoke detector. The trouble condition must be cleared and then the duct smoke detector must be reset in order to restore it to the normal state.

**RESETTING ALARM AND TROUBLE CONDITION TRIPS**

Manual reset is required to restore smoke detector systems to Normal operation. For installations using 2 sensors, the duct smoke

1. Third-party trademarks and logos are the property of their respective owners.

detector does not differentiate which sensor signals an alarm or trouble condition. Check each sensor for Alarm or Trouble status (indicated by LED). Clear the condition that has generated the trip at this sensor. Then reset the sensor by pressing and holding the reset button (on the side) for 2 seconds. Verify that the sensor’s Alarm and Trouble LEDs are now off. At the controller, clear its Alarm or Trouble state by pressing and holding the manual reset button (on the front cover) for 2 seconds. Verify that the controller’s Alarm and Trouble LEDs are now off. Replace all panels.

**Troubleshooting**

**CONTROLLER’S TROUBLE LED IS ON**

1. Check the Trouble LED on each sensor connected to the controller. If a sensor’s Trouble LED is on, determine the cause and make the necessary repairs.
2. Check the wiring between the sensor and the controller. If wiring is loose or missing, repair or replace as required.

**CONTROLLER’S TROUBLE LED IS FLASHING**

1. One or both of the sensors is 100% dirty.
2. Determine which Dirty LED is flashing then clean that sensor assembly as described in the detector cleaning section.

**SENSOR’S TROUBLE LED IS ON**

1. Check the sensor’s Dirty LED. If it is flashing, the sensor is dirty and must be cleaned.
2. Check the sensor’s cover. If it is loose or missing, secure the cover to the sensor housing.
3. Replace sensor assembly.

**SENSOR’S POWER LED IS OFF**

1. Check the controller’s Power LED. If it is off, determine why the controller does not have power and make the necessary repairs.
2. Check the wiring between the sensor and the controller. If wiring is loose or missing, repair or replace as required.

**CONTROLLER’S POWER LED IS OFF**

1. Make sure the circuit supplying power to the controller is operational. If not, make sure JP2 and JP3 are set correctly on the controller before applying power.
2. Verify that power is applied to the controller’s supply input terminals. If power is not present, replace or repair wiring as required.

**REMOTE TEST/RESET STATION’S TROUBLE LED DOES NOT FLASH WHEN PERFORMING A DIRTY TEST, BUT THE CONTROLLER’S TROUBLE LED DOES**

1. Verify that the remote test/station is wired as shown in Fig. 50. Repair or replace loose or missing wiring.
2. Configure the sensor dirty test to activate the controller’s supervision relay. See “Dirty Sensor Test” on page 29.

**SENSOR’S TROUBLE LED IS ON, BUT THE CONTROLLER’S TROUBLE LED IS OFF**

Remove JP1 on the controller.

## PROTECTIVE DEVICES

### Compressor Protection

#### OVERCURRENT

The compressor has internal line-break motor protection.

#### OVERTEMPERATURE

The compressor has an internal protector to protect it against excessively high discharge gas temperatures.

#### HIGH PRESSURE SWITCH

The system is provided with a high pressure switch mounted on the discharge line. The switch is stem-mounted and brazed into the discharge tube. Trip setting is 630 psig  $\pm$  10 psig (4344  $\pm$  69 kPa) when hot. Reset is automatic at 505 psig (3482 kPa).

#### LOW PRESSURE SWITCH

The system is protected against a loss of charge and low evaporator coil loading condition by a low pressure switch located on the suction line near the compressor. The switch is stem-mounted. Trip setting is 54 psig  $\pm$  5 psig (372  $\pm$  34 kPa). Reset is automatic at 117  $\pm$  5 psig (807  $\pm$  34 kPa).

#### EVAPORATOR FREEZE PROTECTION

The system is protected against evaporator coil frosting and low temperature conditions by a temperature switch mounted on the evaporator coil hairpin. Trip setting is 30°F  $\pm$  5°F (-1°C  $\pm$  3°C). Reset is automatic at 45°F (7°C).

#### SUPPLY (INDOOR) FAN MOTOR PROTECTION

Disconnect and lockout power when servicing fan motor.

The standard supply fan motor is equipped with internal overcurrent and over-temperature protection. Protection devices reset automatically.

The high static option supply fan motor is equipped with a pilot-circuit Thermix combination over-temperature/over-current protection device. This device resets automatically. Do not bypass this switch to correct trouble. Determine the cause and correct it.

#### CONDENSER FAN MOTOR PROTECTION

The condenser fan motor is internally protected against over-temperature.

### Relief Device

A soft solder joint at the suction service access port provides pressure relief under abnormal temperature and pressure conditions (i.e., fire in building). Protect this joint during brazing operations near this joint.

### Control Circuit, 24-V

The control circuit is protected against overcurrent conditions by a circuit breaker mounted on control transformer TRAN. Reset is manual.

## SYSTEMVU CONTROL SYSTEM

The SystemVu™ control is a comprehensive unit-management system. The control system is easy to access, configure, diagnose and troubleshoot.

The SystemVu control system is fully communicating and cable-ready for connection to the Carrier Comfort Network® (CCN), Carrier i-Vu®, and Third Party BACnet®<sup>1</sup> building management systems. The control provides high-speed communications for remote monitoring via the Internet. Multiple units can be linked together (and to other Direct Digital Control (DDC) equipped units) using a 3-wire communication bus.

The SystemVu control system is easy to access through the use of an integrated display module. A computer is not required for start-up. Access to control menus is simplified by the ability to quickly select from 7 main menu items. An expanded readout provides detailed explanations of control information. Only 6 buttons are required to maneuver through the entire controls menu. The display readout is designed to be visible even in bright sunlight. See Fig. 53.

### SystemVu Interface

This integrated device is the keypad interface used to access the control information, read sensor values, and test the unit. The interface is located in the main control box.

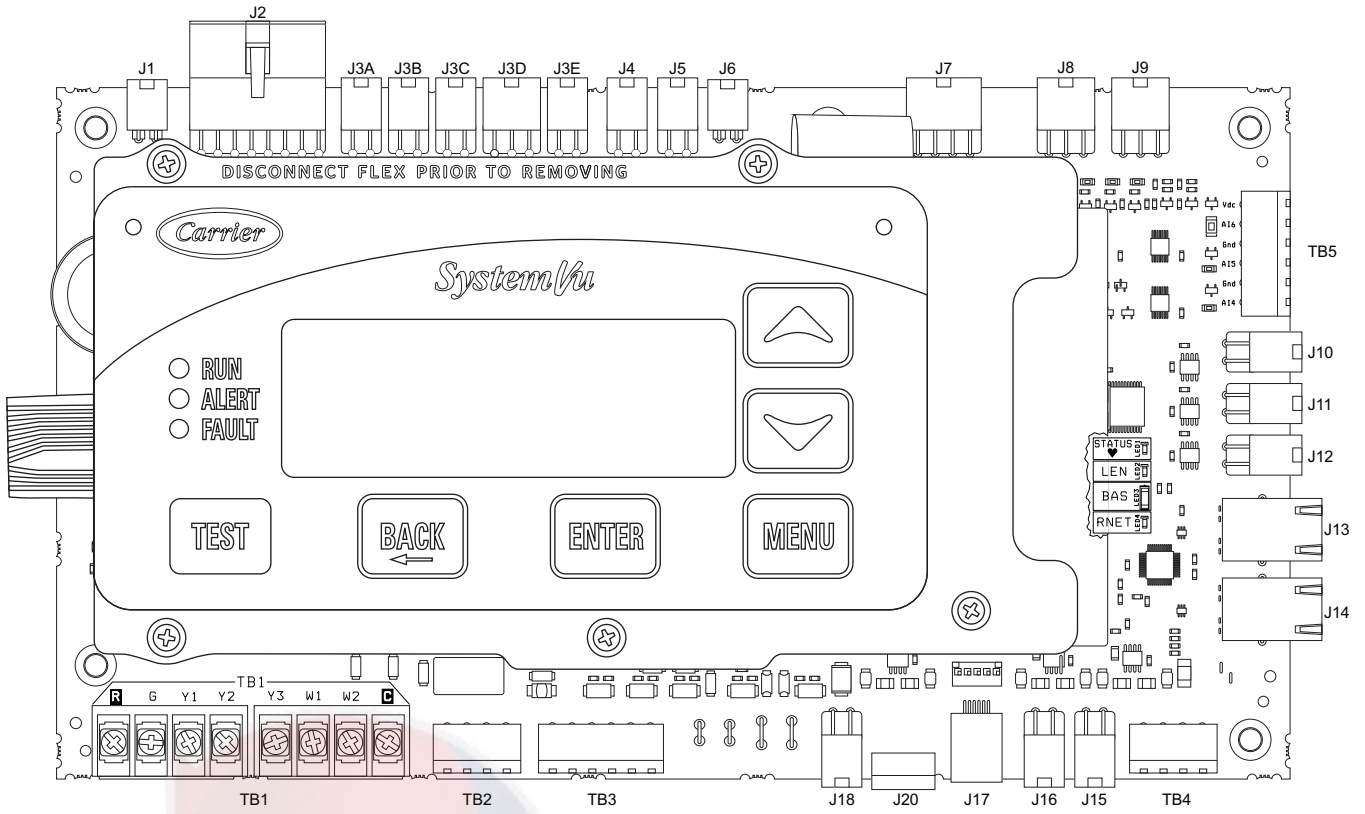
Through the SystemVu interface, the user can access all of the inputs and outputs to check on their values and status, configure operating parameters, and evaluate the current decision status for operating modes. The control also includes an alarm history which can be accessed from the display. The user can access a built-in test routine that can be used at start-up commissioning and troubleshooting.

### Additional SystemVu Installation and Troubleshooting

Additional installation, wiring and troubleshooting information for the SystemVu Controller can be found in the following manual: "50FCQ 04-07, 50GCQ 04-06 Single Package Rooftop Units with SystemVu™ Controls Version X.X Controls, Start-up, Operation and Troubleshooting."

1. Third-party trademarks and logos are the property of their respective owners.





**Fig. 53 — SystemVu Control**



## RTU OPEN CONTROL SYSTEM

The RTU Open controller is an integrated component of the Carrier rooftop unit. Its internal application programming provides optimum performance and energy efficiency. RTU Open enables the unit to run in 100% stand-alone control mode, Carrier's i-Vu® Open network, or a Third Party Building Automation System (BAS). On-board DIP switches allow the user to select your protocol (and baud rate) of choice among the 4 most popular protocols in use today: BACnet, Modbus®<sup>1</sup>, Johnson N2 and LonWorks®<sup>1</sup>. See Fig. 54.

The RTU Open control is factory-mounted in the unit's main control box, to the left of the UCB (unit control board). Factory wiring is completed through harnesses connected to the UCB. Field connections for RTU Open sensors will be made at the PCB connectors on the RTU Open board. The factory-installed RTU Open control includes the supply-air temperature (SAT) sensor. The outdoor air temperature (OAT) sensor is included in the FIOP/accessory EconoMiSer® 2 package.

### Sensory/Accessory Installation

There are a variety of sensors and accessories available for the RTU Open. Some of these can be factory or field installed, while

1. Third-party trademarks and logos are the property of their respective owners.

others are only field installable. The RTU Open controller may also require connection to a building network system or building zoning system. All field control wiring that connects to the RTU Open must be routed through the raceway built into the corner post of the unit or secured to the unit control box with electrical conduit. The unit raceway provides the UL required clearance between high and low-voltage wiring. Pass the control wires through the hole provided in the corner post, then feed the wires through the hole provided in the corner post, then feed the wires through the raceway to the RTU Open. Connect the wires to the removable PCB connectors and then reconnect the connectors to the board.

**IMPORTANT:** Refer to the specific sensor or accessory instructions for its proper installation and for rooftop unit installation refer to base unit installation instructions and the unit's wiring diagrams.

**⚠ WARNING**

**ELECTRICAL SHOCK HAZARD**

Failure to follow this warning could result in personal injury, death and/or equipment damage.

Disconnect and lockout/tag-out electrical power before wiring the RTU Open controller.

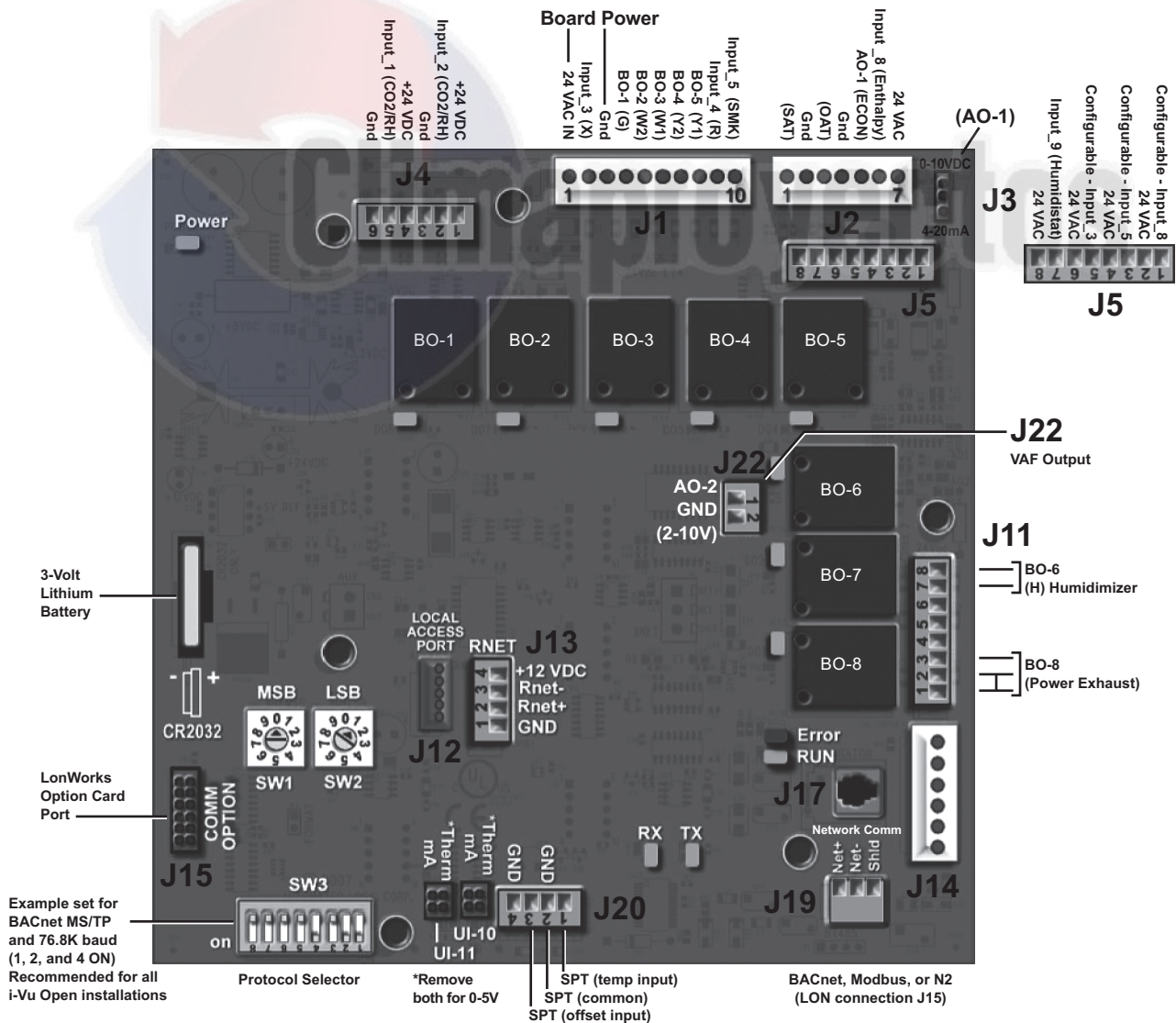


Fig. 54 – RTU Open Control Module

## Additional RTU Open Installation and Troubleshooting

Additional installation, wiring and troubleshooting information for the RTU Open Controller can be found in the following manual: “RTU Open Multi-Protocol Controller Factory-Installed Option — Controls, Start-up, Operation and Troubleshooting Instructions.”

### ECONOMIZER SYSTEMS

The unit may be equipped with a factory-installed or accessory (field-installed) economizer system. Three types are available: 2 with logic control systems (EconoMiSer® X and EconoMiSer IV) and one without a control system (EconoMiSer 2). See Fig. 55-57 for component locations on each type.

NOTE: For 50FCQ rooftop units EconoMiSer IV is available as a factory-installed option for 04-06 units only.

Economizers use direct-drive damper actuators.

**IMPORTANT:** Any economizer that meets the economizer requirements as laid out in California’s Title 24 mandatory section 120.2 (fault detection and diagnostics) and/or prescriptive section 140.4 (life-cycle tests, damper leakage, 5 year warranty, sensor accuracy, etc), will have a label on the economizer. Any economizer without this label does not meet California’s Title 24. The 5 year limited parts warranty referred to in section 140.4 only applies to factory installed economizers. Please refer to your economizer on your unit.

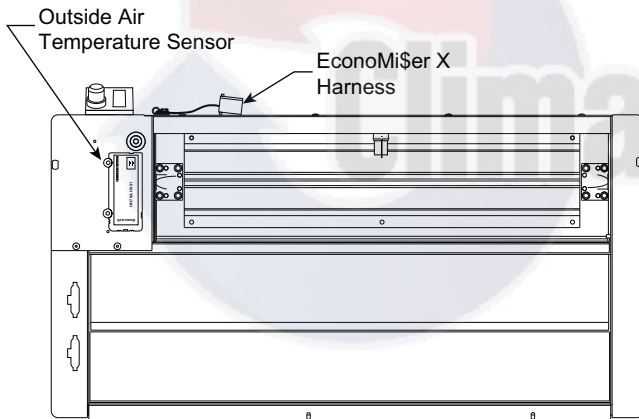


Fig. 55 — EconoMiSer X Component Locations

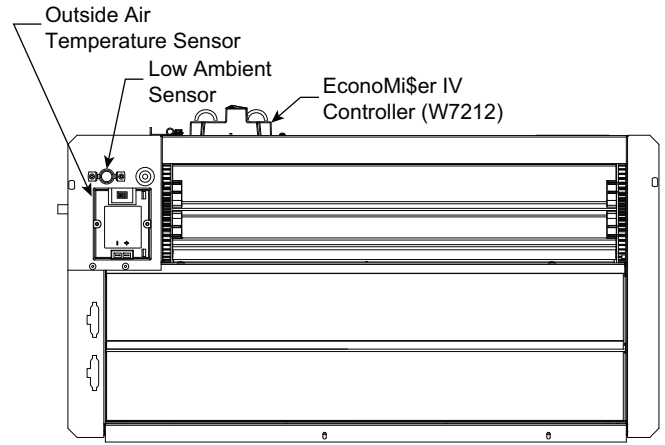


Fig. 56 — EconoMiSer IV Component Locations

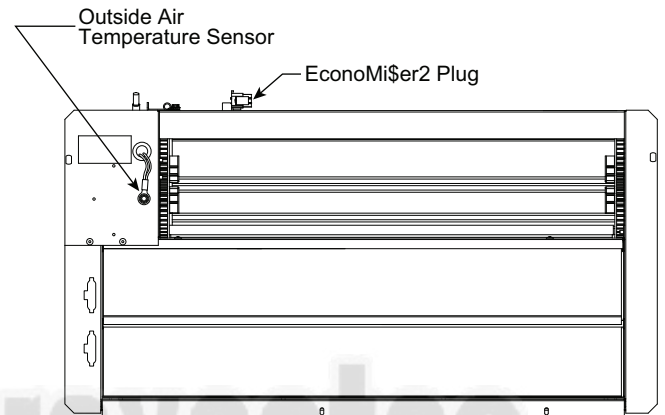
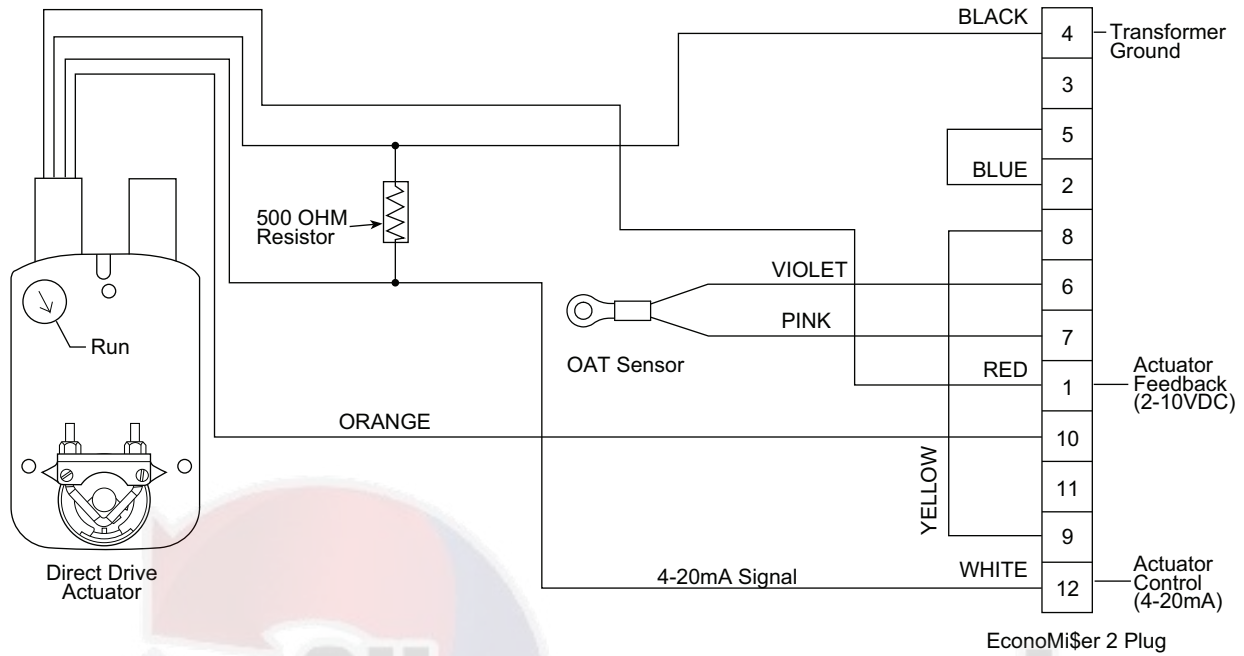


Fig. 57 — EconoMiSer 2 Component Locations

## EconoMiSer 2

**IMPORTANT:** The optional EconoMiSer<sup>®</sup> 2 does not include a controller. The EconoMiSer 2 is operated by a 4 to 20 mA signal from an existing field-supplied controller. See Fig. 58 for wiring information.



**Fig. 58 — EconoMiSer 2 with 4 to 20 mA Control Wiring**

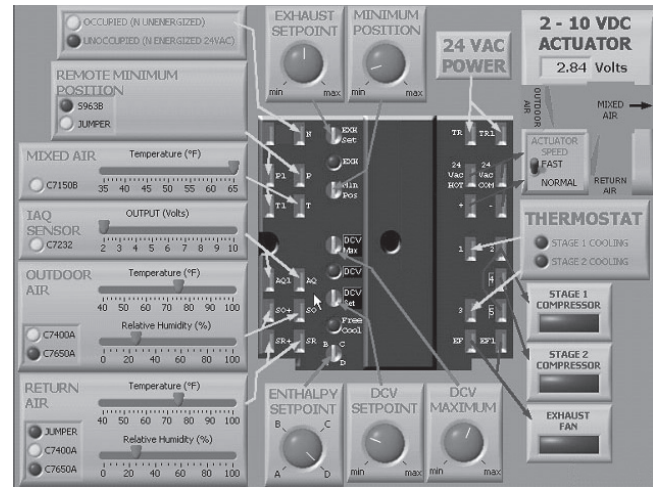


## EconoMi\$er IV (Field-Installed Accessory)

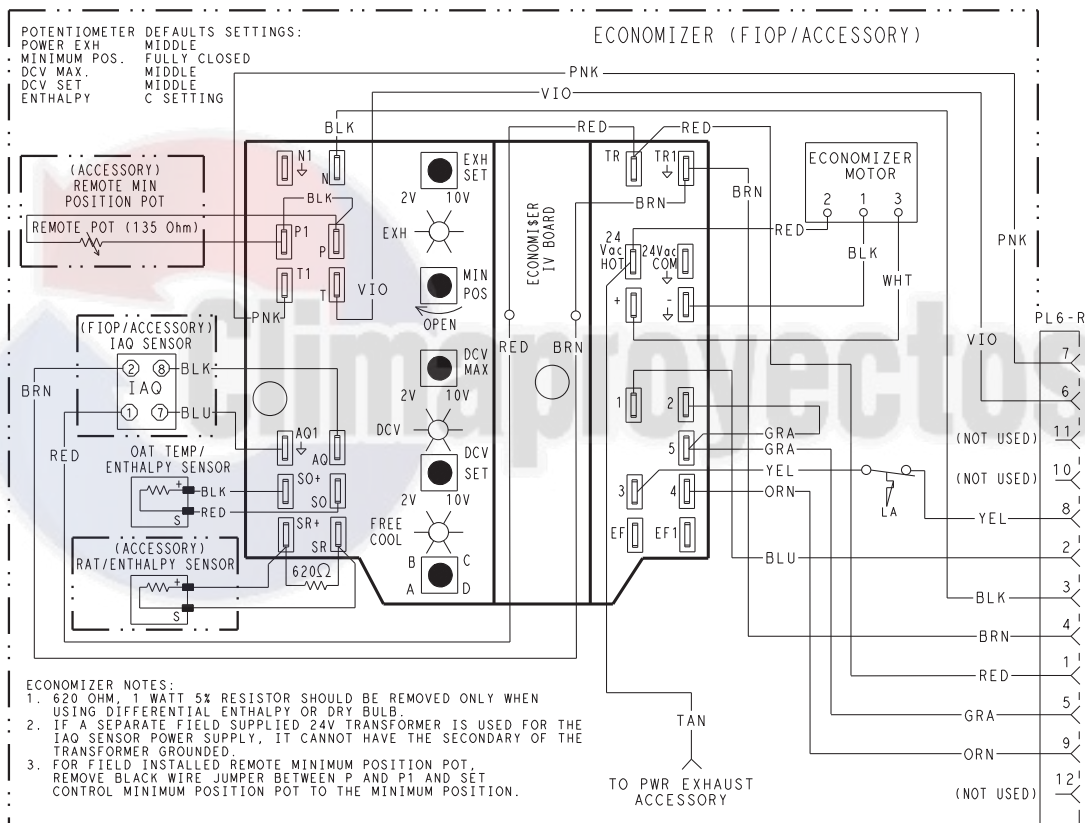
**IMPORTANT:** For FCQ rooftop units EconoMi\$er IV is available as a factory-installed option for 04-06 units only.

### ECONOMISER IV STANDARD SENSORS

Troubleshooting instructions are enclosed. A functional view of the EconoMi\$er® IV accessory is shown in Fig. 59. Typical settings, sensor ranges, and jumper positions are also shown. An EconoMi\$er IV simulator program is available to help with EconoMi\$er IV training and troubleshooting. See Fig. 60 and Table 11 for further details.



**Fig. 59 — EconoMi\$er IV Functional View**



### LEGEND

- DCV** — Demand Controlled Ventilation
- IAQ** — Indoor Air Quality
- LA** — Low Ambient Lockout Device
- OAT** — Outdoor-Air Temperature
- POT** — Potentiometer
- RAT** — Return-Air Temperature

**Fig. 60 — Typical EconoMi\$er IV (W7212 Controller) Wiring**

**Table 11 – EconoMi\$er IV Input/Output Logic**

Demand Controlled Ventilation (DCV)	INPUTS				OUTPUTS			
	Enthalpy <sup>a</sup>		Y1	Y2	Compressor		N Terminal <sup>b</sup>	
	Outdoor	Return			Stage 1	Stage 2	Occupied	Unoccupied
Below Set (DCV LED Off)	High (Free Cooling LED Off)	Low	On	On	On	On	Minimum position	Closed
			On	Off	On	Off		
			Off	Off	Off	Off		
	Low (Free Cooling LED On)	High	On	On	On	Off	Modulating <sup>c</sup> (between minimum position and full-open)	Modulating <sup>c</sup> (between closed and full-open)
			On	Off	Off	Off		
			Off	Off	Off	Off		
Above Set (DCV LED On)	High (Free Cooling LED Off)	Low	On	On	On	On	Modulating <sup>d</sup> (between minimum position and DCV maximum)	Modulating <sup>d</sup> (between closed and DCV maximum)
			On	Off	On	Off		
			Off	Off	Off	Off		
	Low (Free Cooling LED On)	High	On	On	On	Off	Modulating <sup>e</sup>	Modulating <sup>f</sup>
			On	Off	Off	Off		
			Off	Off	Off	Off		

NOTE(S):

- a. For single enthalpy control, the module compares outdoor enthalpy to the ABCD set point.
- b. Power at N terminal determines Occupied/Unoccupied setting: 24 vac (Occupied), no power (Unoccupied).
- c. Modulation is based on the supply-air sensor signal.
- d. Modulation is based on the DCV signal.
- e. Modulation is based on the greater of DCV and supply-air sensor signals, between minimum position and either maximum position (DCV) or fully open (supply-air signal).
- f. Modulation is based on the greater of DCV and supply-air sensor signals, between closed and either maximum position (DCV) or fully open (supply-air signal).

**Outdoor Air Temperature (OAT) Sensor**

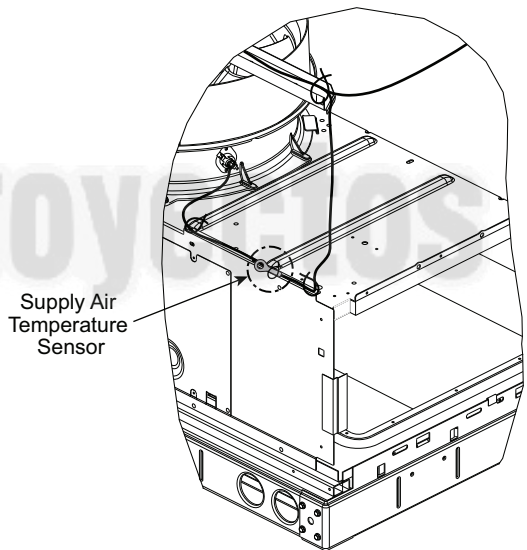
The outdoor air temperature sensor (P/N: HH57AC074) is a 10 to 20 mA device used to measure the outdoor-air temperature. The outdoor-air temperature is used to determine when the EconoMi\$er IV can be used for free cooling. The sensor has 8 selectable temperature changeover setpoints, ranging from 48°F to 78°F. The temperature changeover is set using the 3 DIP switches on the sensor. See Fig. 61.



**Fig. 61 – C7660 Temperature Sensor**

**Supply Air Temperature (SAT) Sensor**

The supply air temperature sensor is a field-installed 3 K thermistor located on the fan deck. See Fig. 62. This sensor is factory installed. The operating range of temperature measurement is 0°F to 158°F (-18°C to 70°C). See Table 12 on page 39 for sensor temperature/resistance values.



**Fig. 62 – Supply Air Sensor Location**

The temperature sensor looks like an eyelet terminal with wires running to it. The sensor is located in the “crimp end” and is sealed from moisture.

**Outdoor Air Lockout Sensor**

The EconoMi\$er IV is equipped with an ambient temperature lockout switch located in the outdoor airstream which is used to lock out the compressors below a 42°F (6°C) ambient temperature. See Fig. 56 on page 35.

**Table 12 — Supply Air Sensor Temperature/Resistance Values**

TEMPERATURE (°F)	RESISTANCE (ohms)
-58	220,250
-40	100,000
-22	53,010
-4	29,091
14	16,500
32	9,795
50	5,970
68	3,747
77	3,000
86	2,416
104	1,597
122	1,080
140	746
158	525
176	376
185	321
194	274
212	203
230	153
248	116
257	102
266	89
284	70
302	55

**ECONOMISER IV CONTROL MODES**

Determine the EconoMiSer IV control mode before set up of the control. Some modes of operation may require different sensors. The EconoMiSer IV accessory is supplied from the factory with a supply-air temperature sensor and an outdoor-air temperature sensor. This allows for operation of the EconoMiSer IV with outdoor air dry bulb changeover control. Additional accessories can be added to allow for different types of changeover control and operation of the EconoMiSer IV and unit.

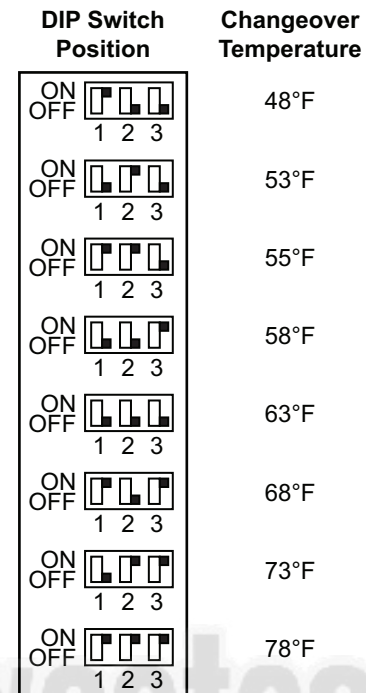
**Outdoor Dry Bulb Changeover**

The standard controller is shipped from the factory configured for outdoor dry bulb changeover control. For this control mode, the outdoor temperature is compared to a selectable set point on the OAT sensor. If the outdoor air temperature is above the set point, the EconoMiSer IV will adjust the outdoor air dampers to minimum position. If the outdoor air temperature is below the set point, the position of the outdoor air dampers will be controlled to provide free cooling using outdoor air. When in this mode, the Free Cool LED next to the outdoor enthalpy set point (ABCD) potentiometer will be on. The changeover temperature set point is controlled by the DIP switches on the sensor. See Fig. 63 for the switch positions corresponding to the temperature changeover values. The ABCD potentiometer on the controller should be turned fully clockwise (CW) to the “D” position. See Fig. 64 for damper leakage.

**Outdoor Enthalpy Changeover**

For enthalpy control, accessory enthalpy sensor (P/N: HH57AC078) is required. Replace the standard outdoor dry

bulb temperature sensor with the accessory enthalpy sensor in the same mounting location. See Fig. 65. When the outdoor air enthalpy rises above the outdoor enthalpy changeover set point, the outdoor-air damper moves to its minimum position. The outdoor enthalpy changeover set point is set with the outdoor enthalpy set point potentiometer on the EconoMiSer® IV controller. The set points are A, B, C, and D. See Fig. 66 and 67. The factory-installed 620-ohm jumper must be in place across terminals S<sub>R</sub> and SR+ on the EconoMiSer IV controller.

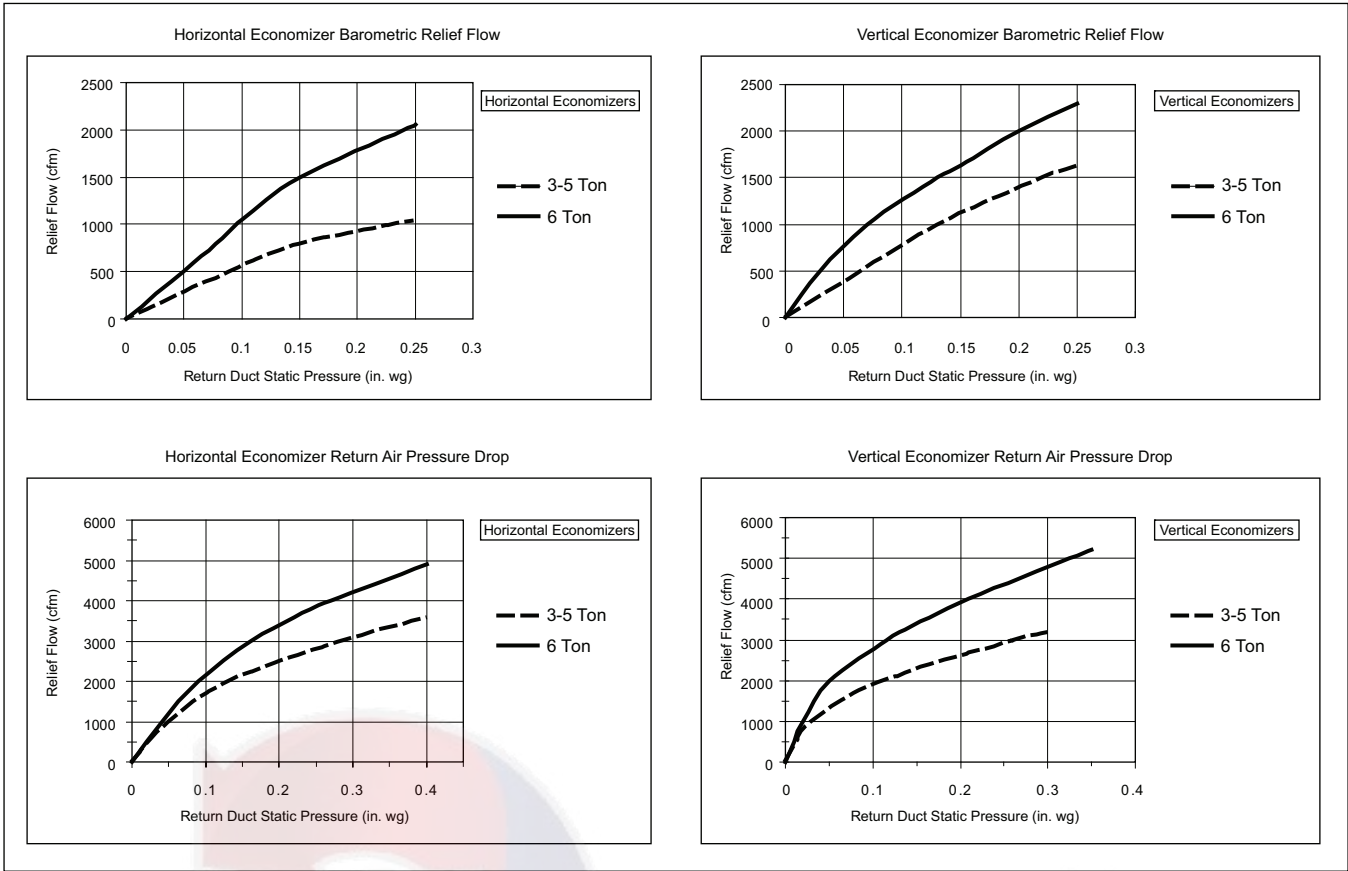


**Fig. 63 — Outdoor Air Temperature Changeover Set Points**

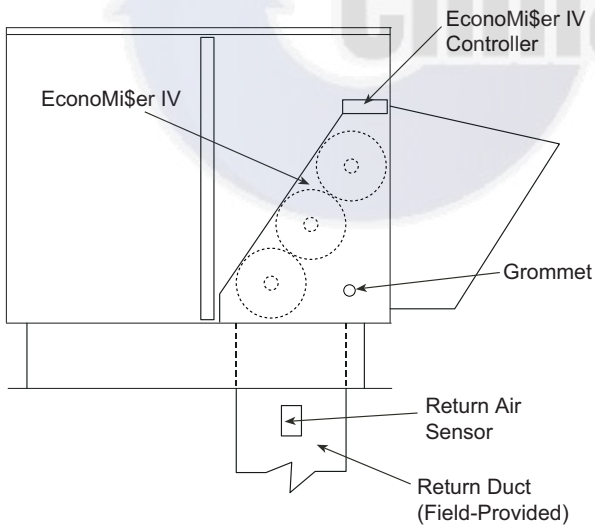
**Differential Enthalpy Control**

For differential enthalpy control, the EconoMiSer IV controller uses 2 enthalpy sensors (P/N: HH57AC078 and CRENT-DIF004A00), one in the outside air and one in the return air duct. The EconoMiSer IV controller compares the outdoor air enthalpy to the return air enthalpy to determine EconoMiSer IV use. The controller selects the lower enthalpy air (return or outdoor) for cooling. For example, when the outdoor air has a lower enthalpy than the return air, the EconoMiSer IV opens to bring in outdoor air for free cooling.

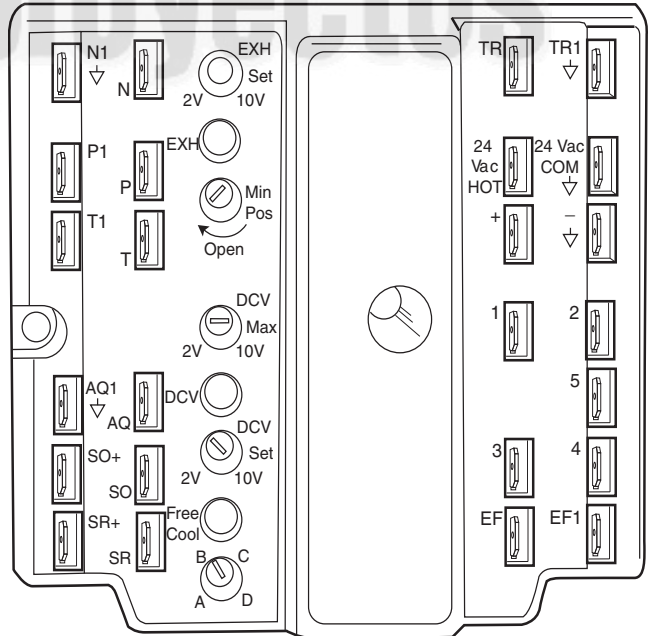
Replace the standard outside air dry bulb temperature sensor with the accessory enthalpy sensor in the same mounting location. See Fig. 56 on page 35. Mount the return air enthalpy sensor in the return air duct. See Fig. 65. Wiring is provided in the EconoMiSer IV wiring harness. See Fig. 60 on page 37. The outdoor enthalpy changeover set point is set with the outdoor enthalpy set point potentiometer on the EconoMiSer IV controller. When using this mode of changeover control, turn the enthalpy set point potentiometer fully clockwise to the D setting. See Fig. 66 and 67.



**Fig. 64 — Outdoor-Air Damper Leakage**

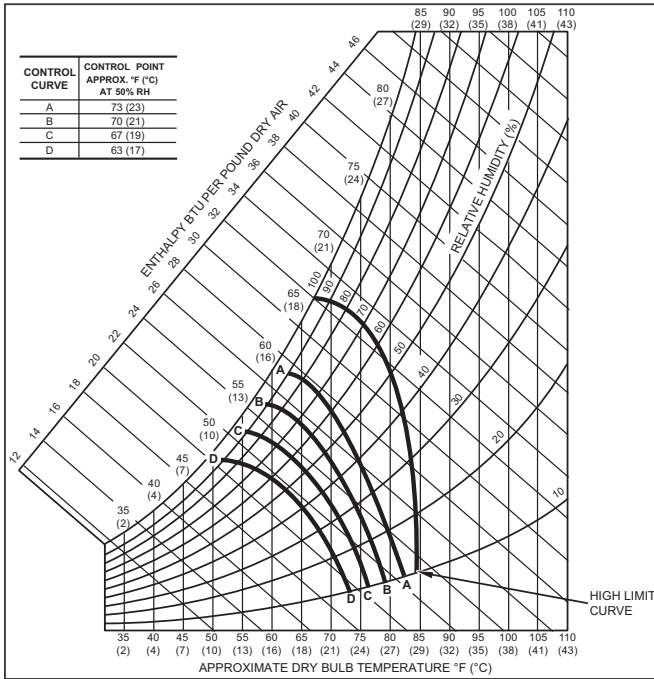


**Fig. 65 — Return Air Temperature or Enthalpy Sensor Mounting Location**



**Fig. 66 — EconoMiSer IV W7212 Control**





**Fig. 67 — Enthalpy Changeover Set Points**

**Indoor Air Quality (IAQ) Sensor Input**

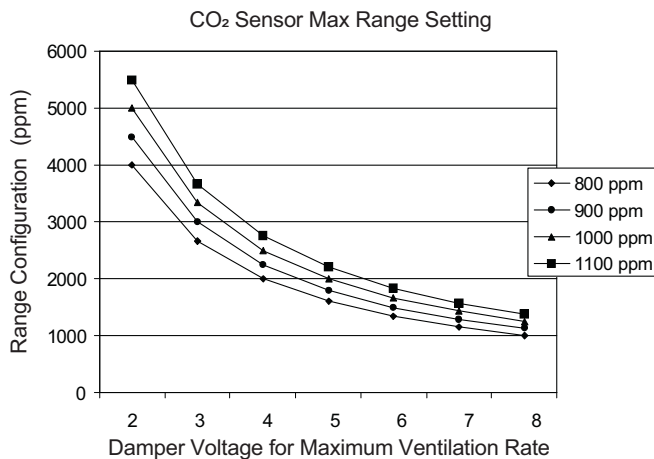
The IAQ input can be used for demand controlled ventilation control based on the level of CO<sub>2</sub> measured in the space or return air duct.

Mount the accessory IAQ sensor according to manufacturer specifications. The IAQ sensor should be wired to the AQ and AQ1 terminals of the controller. Adjust the DCV potentiometers to correspond to the DCV voltage output of the indoor air quality sensor at the user-determined set point. See Fig. 68.

If a separate field-supplied transformer is used to power the IAQ sensor, the sensor must not be grounded or the EconoMiSer® IV control board will be damaged.

When using demand controlled ventilation, the minimum damper position represents the minimum ventilation position for VOC (volatile organic compounds) ventilation requirements. The maximum demand ventilation position is used for fully occupied ventilation.

When demand controlled ventilation is not being used, the minimum position potentiometer should be used to set the occupied ventilation position. The maximum demand ventilation position should be turned fully clockwise.



**Fig. 68 — CO<sub>2</sub> Sensor Maximum Range Settings**

**Exhaust Set Point Adjustment**

The exhaust set point will determine when the exhaust fan runs based on damper position (if accessory power exhaust is installed). The set point is modified with the Exhaust Fan set point (EXH SET) potentiometer. See Fig. 66. The set point represents the damper position above which the exhaust fans will be turned on. When there is a call for exhaust, the EconoMiSer IV controller provides a 45 ± 15 second delay before exhaust fan activation to allow the dampers to open. This delay allows the damper to reach the appropriate position to avoid unnecessary fan overload.

**Minimum Position Control**

There is a minimum damper position potentiometer on the EconoMiSer IV controller. See Fig. 66. The minimum damper position maintains the minimum airflow into the building during the occupied period.

When using demand controlled ventilation, the minimum damper position represents the minimum ventilation position for Volatile Organic Compound (VOC) ventilation requirements. The maximum demand ventilation position is used for fully occupied ventilation.

When demand controlled ventilation is not being used, the minimum position potentiometer should be used to set the occupied ventilation position. The maximum demand ventilation position should be turned fully clockwise.

Adjust the minimum position potentiometer to allow the minimum amount of outdoor air, as required by local codes, to enter the building. Make minimum position adjustments with at least 10°F temperature difference between the outdoor and return-air temperatures.

To determine the minimum position setting, perform the following procedure:

1. Calculate the appropriate mixed air temperature using the following formula:

$$(T_O \times \frac{OA}{100}) + (T_R \times \frac{RA}{100}) = T_M$$

T<sub>O</sub> = Outdoor-Air Temperature

OA = Percent of Outdoor Air

T<sub>R</sub> = Return-Air Temperature

RA = Percent of Return Air

T<sub>M</sub> = Mixed-Air Temperature

As an example, if local codes require 10% outdoor air during occupied conditions, outdoor-air temperature is 60°F, and return-air temperature is 75°F.

$$(60 \times 0.10) + (75 \times 0.90) = 73.5^\circ\text{F}$$

2. Disconnect the supply air sensor from terminals T and T1.
3. Ensure that the factory-installed jumper is in place across terminals P and P1. If remote damper positioning is being used, make sure that the terminals are wired according to Fig. 60 and that the minimum position potentiometer is turned fully clockwise.
4. Connect 24 vac across terminals TR and TR1.
5. Carefully adjust the minimum position potentiometer until the measured mixed air temperature matches the calculated value.
6. Reconnect the supply air sensor to terminals T and T1.

Remote control of the EconoMiSer IV damper is desirable when requiring additional temporary ventilation. If a field-supplied remote potentiometer (Honeywell P/N: S963B1128) is wired to the EconoMiSer IV controller, the minimum position of the damper can be controlled from a remote location.

To control the minimum damper position remotely, remove the factory-installed jumper on the P and P1 terminals on the EconoMiSer IV controller. Wire the field-supplied potentiometer to the P and P1 terminals on the EconoMiSer® IV controller. (See Fig. 66.)

### Damper Movement

Damper movement from full open to full closed (or vice versa) takes 2-1/2 minutes.

### Thermostats

The EconoMiSer IV control works with conventional thermostats that have a Y1 (cool stage 1), Y2 (cool stage 2), W1 (heat stage 1), W2 (heat stage 2), and G (fan). The EconoMiSer IV control does not support space temperature sensors. Connections are made at the thermostat terminal connection board located in the main control box.

### Occupancy Control

The factory default configuration for the EconoMiSer IV control is occupied mode. Occupied status is provided by the black jumper from terminal TR to terminal N. When unoccupied mode is desired, install a field-supplied timeclock function in place of the jumper between TR and N. When the timeclock contacts are closed, the EconoMiSer IV control will be in occupied mode. When the timeclock contacts are open (removing the 24-v signal from terminal N), the EconoMiSer IV will be in unoccupied mode.

### Demand Controlled Ventilation (DCV)

When using the EconoMiSer IV for demand controlled ventilation, there are some equipment selection criteria which should be considered. When selecting the heat capacity and cool capacity of the equipment, the maximum ventilation rate must be evaluated for design conditions. The maximum damper position must be calculated to provide the desired fresh air.

Typically the maximum ventilation rate will be about 5 to 10% more than the typical cfm required per person, using normal outside air design criteria.

A proportional anticipatory strategy should be taken with the following conditions: a zone with a large area, varied occupancy, and equipment that cannot exceed the required ventilation rate at design conditions. Exceeding the required ventilation rate means the equipment can condition air at a maximum ventilation rate that is greater than the required ventilation rate for maximum occupancy. A proportional-anticipatory strategy will cause the fresh air supplied to increase as the room CO<sub>2</sub> level increases even though the CO<sub>2</sub> set point has not been reached. By the time the CO<sub>2</sub> level reaches the set point, the damper will be at maximum ventilation and should maintain the set point.

In order to have the CO<sub>2</sub> sensor control the economizer damper in this manner, first determine the damper voltage output for minimum or base ventilation. Base ventilation is the ventilation required to remove contaminants during unoccupied periods. The following equation may be used to determine the percent of outside air entering the building for a given damper position. For best results, there should be at least a 10 degree difference in outside and return-air temperatures.

$$(T_O \times \frac{OA}{100}) + (T_R \times \frac{RA}{100}) = T_M$$

T<sub>O</sub> = Outdoor-Air Temperature

OA = Percent of Outdoor Air

T<sub>R</sub> = Return-Air Temperature

RA = Percent of Return Air

T<sub>M</sub> = Mixed-Air Temperature

Once base ventilation has been determined, set the minimum damper position potentiometer to the correct position.

The same equation can be used to determine the occupied or maximum ventilation rate to the building. For example, an output of 3.6 volts to the actuator provides a base ventilation rate of 5% and an output of 6.7 volts provides the maximum ventilation rate of 20% (or base plus 15 cfm per person). Use Fig. 68 to determine the maximum setting of the CO<sub>2</sub> sensor. For example, an 1100 ppm set point relates to a 15 cfm per person design. Use the 1100 ppm curve on Fig. 68 to find the point when the CO<sub>2</sub> sensor

output will be 6.7 volts. Line up the point on the graph with the left side of the chart to determine that the range configuration for the CO<sub>2</sub> sensor should be 1800 ppm. The EconoMiSer IV controller will output the 6.7 volts from the CO<sub>2</sub> sensor to the actuator when the CO<sub>2</sub> concentration in the space is at 1100 ppm. The DCV set point may be left at 2 volts since the CO<sub>2</sub> sensor voltage will be ignored by the EconoMiSer IV controller until it rises above the 3.6 volt setting of the minimum position potentiometer.

Once the fully occupied damper position has been determined, set the maximum damper demand controlled ventilation potentiometer to this position. Do not set to the maximum position as this can result in over-ventilation to the space and potential high humidity levels.

### CO<sub>2</sub> Sensor Configuration

The CO<sub>2</sub> sensor has preset standard voltage settings that can be selected anytime after the sensor is powered up.

Use setting 1 or 2 for Carrier equipment.

1. Press Clear and Mode buttons. Hold at least 5 seconds until the sensor enters the Edit mode.
2. Press Mode twice. The STDSET Menu will appear.
3. Use the Up/Down button to select the preset number.
4. Press Enter to lock in the selection.
5. Press Mode to exit and resume normal operation.

The custom settings of the CO<sub>2</sub> sensor can be changed anytime after the sensor is energized. Follow the steps below to change the non-standard settings:

1. Press Clear and Mode buttons. Hold at least 5 seconds until the sensor enters the Edit mode.
2. Press Mode twice. The STDSET Menu will appear.
3. Use the Up/Down button to toggle to the NONSTD menu and press Enter.
4. Use the Up/Down button to toggle through each of the 9 variables, starting with Altitude, until the desired setting is reached.
5. Press Mode to move through the variables.
6. Press Enter to lock in the selection, then press Mode to continue to the next variable.

### Dehumidification of Fresh Air with DCV (Demand Controlled Ventilation) Control

If normal rooftop heating and cooling operation is not adequate for the outdoor humidity level, an energy recovery unit and/or a dehumidification option should be considered.

### ECONOMISER IV PREPARATION

This procedure is used to prepare the EconoMiSer® IV for troubleshooting. No troubleshooting or testing is done by performing the following procedure.

NOTE: This procedure requires a 9-v battery, 1.2 kilo-ohm resistor, and a 5.6 kilo-ohm resistor which are not supplied with the EconoMiSer IV.

**IMPORTANT:** Be sure to record the positions of all potentiometers before starting troubleshooting.

1. Disconnect power at TR and TR1. All LEDs should be off. Exhaust fan contacts should be open.
2. Disconnect device at P and P1.
3. Jumper P to P1.
4. Disconnect wires at T and T1. Place 5.6 kilo-ohm resistor across T and T1.
5. Jumper TR to 1.
6. Jumper TR to N.
7. If connected, remove sensor from terminals SO and +. Connect 1.2 kilo-ohm 4074EJM checkout resistor across terminals SO and +.

8. Put 620-ohm resistor across terminals SR and +.
9. Set minimum position, DCV set point, and exhaust potentiometers fully CCW (counterclockwise).
10. Set DCV maximum position potentiometer fully CW (clockwise).
11. Set enthalpy potentiometer to D.
12. Apply power (24 vac) to terminals TR and TR1.

#### DIFFERENTIAL ENTHALPY

To check differential enthalpy:

1. Make sure EconoMiSer® IV preparation procedure has been performed.
2. Place 620-ohm resistor across SO and +.
3. Place 1.2 kilo-ohm resistor across SR and +. The Free Cool LED should be lit.
4. Remove 620-ohm resistor across SO and +. The Free Cool LED should turn off.
5. Return EconoMiSer IV settings and wiring to normal after completing troubleshooting.

#### SINGLE ENTHALPY

To check single enthalpy:

1. Make sure EconoMiSer IV preparation procedure has been performed.
2. Set the enthalpy potentiometer to A (fully CCW). The Free Cool LED should be lit.
3. Set the enthalpy potentiometer to D (fully CW). The Free Cool LED should turn off.
4. Return EconoMiSer IV settings and wiring to normal after completing troubleshooting.

#### DCV (DEMAND CONTROLLED VENTILATION) AND POWER EXHAUST

To check DCV and Power Exhaust:

1. Make sure EconoMiSer IV preparation procedure has been performed.
2. Ensure terminals AQ and AQ1 are open. The LED for both DCV and Exhaust should be off. The actuator should be fully closed.
3. Connect a 9-v battery to AQ (positive node) and AQ1 (negative node). The LED for both DCV and Exhaust should turn on. The actuator should drive to between 90 and 95% open.
4. Turn the Exhaust potentiometer CW until the Exhaust LED turns off. The LED should turn off when the potentiometer is approximately 90%. The actuator should remain in position.
5. Turn the DCV set point potentiometer CW until the DCV LED turns off. The DCV LED should turn off when the potentiometer is approximately 9-v. The actuator should drive fully closed.
6. Turn the DCV and Exhaust potentiometers CCW until the Exhaust LED turns on. The exhaust contacts will close 30 to 120 seconds after the Exhaust LED turns on.
7. Return EconoMiSer IV settings and wiring to normal after completing troubleshooting.

#### DCV MINIMUM AND MAXIMUM POSITION

To check the DCV minimum and maximum position:

1. Make sure EconoMiSer IV preparation procedure has been performed.
2. Connect a 9-v battery to AQ (positive node) and AQ1 (negative node). The DCV LED should turn on. The actuator should drive to between 90 and 95% open.
3. Turn the DCV Maximum Position potentiometer to mid-point. The actuator should drive to between 20 and 80% open.
4. Turn the DCV Maximum Position potentiometer to fully CCW. The actuator should drive fully closed.
5. Turn the Minimum Position potentiometer to mid-point. The actuator should drive to between 20 and 80% open.
6. Turn the Minimum Position Potentiometer fully CW. The actuator should drive fully open.
7. Remove the jumper from TR and N. The actuator should drive fully closed.
8. Return EconoMiSer IV settings and wiring to normal after completing troubleshooting.

#### SUPPLY-AIR SENSOR INPUT

To check supply-air sensor input:

1. Make sure EconoMiSer IV preparation procedure has been performed.
2. Set the Enthalpy potentiometer to A. The Free Cool LED turns on. The actuator should drive to between 20 and 80% open.
3. Remove the 5.6 kilo-ohm resistor and jumper T to T1. The actuator should drive fully open.
4. Remove the jumper across T and T1. The actuator should drive fully closed.
5. Return EconoMiSer IV settings and wiring to normal after completing troubleshooting.

#### ECONOMISER IV TROUBLESHOOTING COMPLETION

This procedure is used to return the EconoMiSer IV to operation. No troubleshooting or testing is done by performing the following procedure.

1. Disconnect power at TR and TR1.
2. Set enthalpy potentiometer to previous setting.
3. Set DCV maximum position potentiometer to previous setting.
4. Set minimum position, DCV set point, and exhaust potentiometers to previous settings.
5. Remove 620-ohm resistor from terminals SR and +.
6. Remove 1.2 kilo-ohm checkout resistor from terminals SO and +. If used, reconnect sensor from terminals SO and +.
7. Remove jumper from TR to N.
8. Remove jumper from TR to 1.
9. Remove 5.6 kilo-ohm resistor from T and T1. Reconnect wires at T and T1.
10. Remove jumper from P to P1. Reconnect device at P and P1.
11. Apply power (24 vac) to terminals TR and TR1.



## EconoMi\$er X (Factory Option)

The EconoMi\$er<sup>®</sup> X system is an expandable economizer control system, which includes a W7220 economizer module (controller) with an LCD and keypad (see Fig. 69). The W7220 can be configured with optional sensors. See Fig. 70 for wiring.



Fig. 69 — W7220 Economizer Module

The W7220 economizer module can be used as a stand-alone economizer module wired directly to a commercial set-back space thermostat and sensors to provide outside air dry-bulb economizer control.

The W7220 economizer module can be connected to optional sensors for single or differential enthalpy control. The W7220 economizer module provides power and communications for the sensors.

The W7220 economizer module automatically detects sensors by polling to determine which sensors are present. If a sensor loses communications after it has been detected, the W7220 economizer controller indicates a device fail error on its LCD.

### SYSTEM COMPONENTS

The EconoMi\$er X system includes an economizer module, 20k mixed air sensor, damper actuator, and either a 20k outdoor air temperature sensor or S-Bus enthalpy sensors.

## Economizer Module

The module is the core of the EconoMi\$er X system. The module is mounted in the unit's control box, and includes the user interface for the system. The W7220 economizer module provides the basic inputs and outputs to provide simple economizer control. When used with the optional sensors, the economizer module provides more advanced economizer functionality.

### S-Bus Enthalpy Control Sensors

The sensor is a combination temperature and humidity sensor which is powered by and communicates on the S-Bus. Up to 3 sensors may be configured with the W7220 economizer module.

### CO<sub>2</sub> Sensor (optional)

The sensor can be added for Demand Controlled Ventilation (DCV).

## SPECIFICATIONS

### W7220 Economizer Module

The module is designed for use with 2 to 10 vdc or bus communicating actuator. The module includes terminals for CO<sub>2</sub> sensor, Mixed Air sensor, and an Outdoor Dry Bulb sensor. Enthalpy and other options are available with bus sensors.

### User Interface

Provides status for normal operation, setup parameters, checkout tests, and alarm and error conditions with a 2-line 16 character LCD display and 4 button keypad.

### Electrical

- Rated Voltage — 20 to 30 vac RMS, 50/60 Hz
- Transformer — 100 va maximum system input
- Nominal Power Consumption (at 24 vac, 60 Hz) — 11.5 VA without sensors or actuators
- Relay Digital Output Rating at 30 vac (maximum power from Class 2 input only) — 1.5A run: 3.5A inrush at 0.45PF (200,000 cycles) or 7.5A inrush at 0.45PF (100,000 cycles)
- External Sensors Power Output — 21 vdc  $\pm$  5% at 48 mA

**IMPORTANT:** All inputs and outputs must be Class 2 wiring.

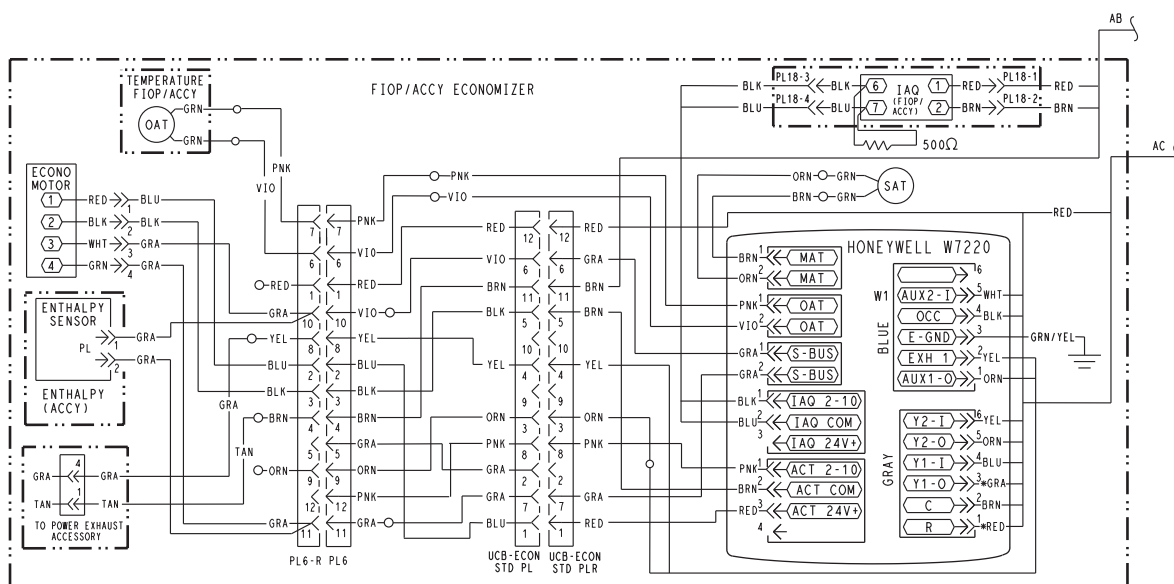


Fig. 70 — Typical EconoMi\$er X (W7220 Controller) Wiring



## INPUTS

### Sensors

NOTE: A Mixed Air (MA) analog sensor is required on all W7220 units; either an Outdoor Air (OA) sensor for dry bulb change over or an OA bus sensor for outdoor enthalpy change over is required in addition to the MA sensor. An additional Return Air (RA) bus sensor can be added to the system for differential enthalpy or dry bulb changeover. For differential dry bulb changeover a 20k ohm sensor is required in the OA and a bus sensor in the RA. DIP switch on RA bus sensor must be set in the RA position.

#### Dry Bulb Temperature (optional) and Mixed Air (required), 20k NTC

2-wire (18 to 22 AWG);

Temperature range -40 to 150°F (-40 to 65°C)

Temperature accuracy -0°F/+2°F

#### Temperature and Humidity, C7400S1000 (optional)

S-Bus; 2-wire (18 to 22 AWG)

Temperature: range -40 to 150°F (-40 to 65°C)

Temperature accuracy -0°F/+2°F

Humidity: range 0 to 100% RH with 5% accuracy.

NOTE: Up to 3 S-Bus sensors may be connected to the W7220 economizer module. For outdoor air (OA), return air (RA) and discharge (supply) air (DA).

#### 4 Binary Inputs

1-wire 24 vac + common GND (see page 46 for wiring details).

#### 24 vac power supply

20 to 30 vac 50/60 Hz; 100 VA Class 2 transformer.

## OUTPUTS

### Actuator Signal

2-10 vdc; minimum actuator impedance is 2k ohm; bus 2-wire output for bus communicating actuators.

#### Exhaust fan, Y1, Y2 and AUX1 O

All Relay Outputs (at 30 vac):

Running: 1.5A maximum

Inrush: 7.5A maximum

## ENVIRONMENTAL

### Operating Temperature

-40 to 150°F (-40 to 65°C).

Exception of display operation down to -4°F (-20°C) with full recovery at -4°F (-20°C) from exposure to -40°F (-40°C).

#### Storage Temperature

-40 to 150°F (-40 to 65°C)

#### Shipping Temperature

-40 to 150°F (-40 to 65°C)

#### Relative Humidity

5% to 95% RH non-condensing

## ECONOMIZER MODULE WIRING DETAILS

Use Fig. 71 and Tables 13 and 14 to locate the wiring terminals for the Economizer module.

NOTE: The 4 terminal blocks are removable. Slide out each terminal block, wire it, and then slide it back into place.

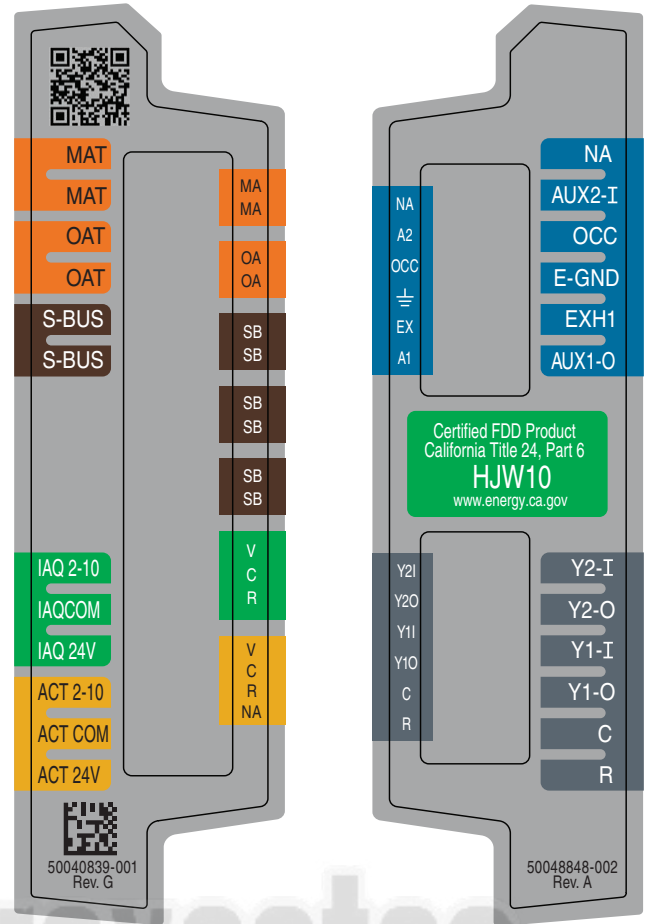


Fig. 71 — W7220 Wiring Terminals

Table 13 — Economizer Module — Left Hand Terminal Blocks

LABEL	TYPE	DESCRIPTION
<b>Top Left Terminal Block</b>		
<b>MAT</b>	20k NTC and COM	Mixed Air Temperature Sensor (Polarity Insensitive Connection)
<b>OAT</b>	20k NTC and COM	Outdoor Air Temperature Sensor (Polarity Insensitive Connection)
<b>S-BUS</b>	S-BUS (Sylk™ <sup>a</sup> Bus)	Enthalpy Control Sensor (Polarity Insensitive Connection)
<b>Bottom Left Terminal Block</b>		
<b>IAQ 2-10</b>	2-10 vdc	Air Quality Sensor Input (e.g. CO <sub>2</sub> sensor)
<b>IAQ COM</b>	COM	Air Quality Sensor Common
<b>IAQ 24V</b>	24 vac	Air Quality Sensor 24 vac Source
<b>ACT 2-10</b>	2-10 vdc	Damper Actuator Output (2-10 vdc)
<b>ACT COM</b>	COM	Damper Actuator Output Common
<b>ACT 24v</b>	24 vac	Damper Actuator 24 vac Source

NOTE(S):

- Third-party trademarks and logos are the property of their respective owners.

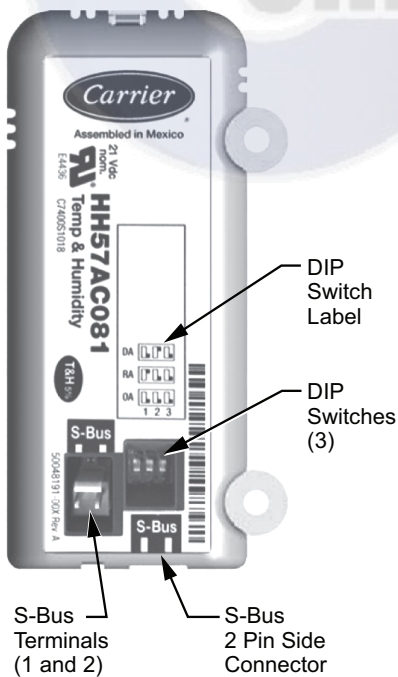
**Table 14 — Economizer Module — Right Hand Terminal Blocks**

LABEL	TYPE	DESCRIPTION
<b>Top Right Terminal Blocks</b>		
AUX2 I	24 vac IN	The first terminal is not used.
OCC	24 vac IN	Shut Down (SD) or HEAT (W) Conventional only and Heat Pump Changeover (O-B) in Heat Pump mode
E-GND	E-GND	Occupied/Unoccupied Input
EXH1	24 vac OUT	Exhaust Fan 1 Output
AUX1 O	24 vac OUT	Programmable: Exhaust fan 2 output or ERV or System alarm output
<b>Bottom Right Terminal Blocks</b>		
Y2-I	24 vac IN	Y2 in — Cooling Stage 2 Input from space thermostat
Y2-O	24 vac OUT	Y2 out — Cooling Stage 2 Output to stage 2 mechanical cooling
Y1-I	24 vac IN	Y1 in — Cooling Stage 2 Input from space thermostat
Y1-O	24 vac OUT	Y1 out — Cooling Stage 2 Output to stage 2 mechanical cooling
C	COM	24 vac Common
R	24 vac	24 vac Power (hot)

**S-BUS SENSOR WIRING**

The labels on the sensors and controller are color coded for ease of installation. Orange labeled sensors can only be wired to orange terminals on the controller. Brown labeled sensors can only be wired to S-bus (brown) terminals. Use Fig. 72 and Table 15 to locate the wiring terminals for each S-Bus sensor.

Use Fig. 72 and Table 15 to locate the wiring terminals for each enthalpy control sensor.



**Fig. 72 — S-Bus Sensor DIP Switches**

**Table 15 — P/N HH57AC081 Sensor Wiring Terminations**

TERMINAL		TYPE	DESCRIPTION
NUMBER	LABEL		
1	S-BUS	S-BUS	S-BUS Communications (Enthalpy Control Sensor Bus)
2	S-BUS	S-BUS	S-BUS Communications (Enthalpy Control Sensor Bus)

Use Fig. 72 and Table 16 to set the DIP switches for the desired use of the sensor.

**Table 16 — P/N HH57AC081 Sensor DIP Switch**

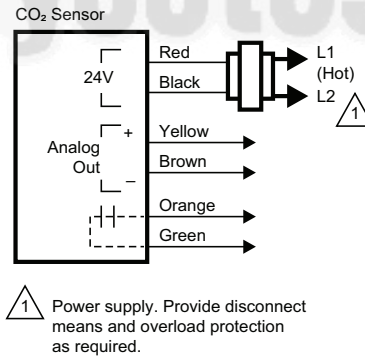
USE	DIP SWITCH POSITIONS FOR SWITCHES 1, 2, AND 3		
	1	2	3
DA	OFF	ON	OFF
RA	ON	OFF	OFF
OA	OFF	OFF	OFF

NOTE: When an S-Bus sensor is connected to an existing network, it will take 60 minutes for the network to recognize and auto-configure itself to use the new sensor.

During the 60-minute setup period, no alarms for sensor failures (except SAT) will be issued and no economizing function will be available.

**CO<sub>2</sub> SENSOR WIRING**

When using a CO<sub>2</sub> sensor the black and brown common wires are internally connected and only one is connected to “IAQ COM” on the W7220. Use the power from the W7220 to power the CO<sub>2</sub> sensor OR make sure the ground for the power supplies are common. See Fig. 73 for CO<sub>2</sub> sensor wiring.



**Fig. 73 — CO<sub>2</sub> Sensor Wiring**

## INTERFACE OVERVIEW

This section describes how to use the EconoMiSer® X user interface for:

- Keypad and menu navigation
- Settings and parameter changes
- Menu structure and selection

### User Interface

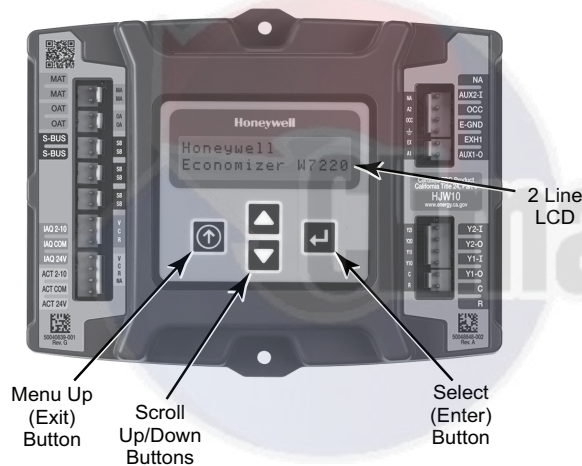
The user interface consists of a 2-line LCD display and a 4-button keypad on the front of the economizer controller.

### Keypad

Use the 4 navigation buttons (see Fig. 74) to scroll through the menus and menu items, select menu items, and to change parameter and configuration settings.

To use the keypad when working with menus:

- Press the ▲ (Up arrow) button to move to the previous menu.
- Press the ▼ (Down arrow) button to move to the next menu.
- Press the ↵ (Enter) button to display the first item in the currently displayed menu.
- Press the ⏪ (Menu Up/Exit) button to exit a menu's item and return to the list of menus.



**Fig. 74 — W7220 Controller Navigation Buttons**

To use the keypad when working with Setpoints, System and Advanced Settings, Checkout tests and Alarms:

1. Navigate to the desired menu.
2. Press the ↵ (Enter) button to display the first item in the currently displayed menu.
3. Use the ▲ and ▼ buttons to scroll to the desired parameter.

4. Press the ↵ (Enter) button to display the value of the currently displayed item.
5. Press the ▲ button to increase (change) the displayed parameter value.
6. Press the ▼ button to decrease (change) the displayed parameter value.

NOTE: When values are displayed, pressing and holding the ▲ or ▼ button causes the display to automatically increment or decrement.

7. Press the ↵ (Enter) button to accept the displayed value and store it in nonvolatile RAM. “CHANGE STORED” displays.
8. Press the ↵ (Enter) button to return to the current menu parameter.
9. Press the ⏪ (Menu Up/Exit) button to return to the previous menu.

### Menu Structure

Table 17 illustrates the complete hierarchy of menus and parameters for the EconoMiSer® X system.

The Menus in display order are:

- STATUS
- SETPOINTS
- SYSTEM SETUP
- ADVANCED SETUP
- CHECKOUT
- ALARMS

NOTE: Some parameters in the menu use the letters MA or MAT, indicating a mixed air temperature sensor location before the cooling coil. This unit application has the control sensor located after the cooling coil, in the fan section, where it is designated as (Cooling) Supply Air Temperature or SAT sensor.

### Setup and Configuration

Before being placed into service, the W7220 Economizer module must be set up and configured for the installed system.

**IMPORTANT:** During setup, the economizer module is live at all times.

The setup process uses a hierarchical menu structure that is easy to use. Press the ▲ and ▼ arrow buttons to move forward and backward through the menus and press the button to select and confirm setup item changes.

### Time-Out and Screensaver

When no buttons have been pressed for 10 minutes, the LCD displays a screen saver, which cycles through the Status items. Each Status items displays in turn and cycles to the next item after 5 seconds.

**Table 17 – W7220 Menu Structure<sup>a</sup>**

MENU	PARAMETER	PARAMETER DEFAULT VALUE	PARAMETER RANGE AND INCREMENT <sup>b</sup>	EXPANDED PARAMETER NAME NOTES
STATUS	ECON AVAIL	NO	YES/NO	FIRST STAGE COOLING DEMAND (Y1-IN) YES = economizing available; the system can use outside air for free cooling when required.
	ECONOMIZING	NO	YES/NO	FIRST STAGE COOLING RELAY OUTPUT YES = outside air being used for first stage cooling
	OCCUPIED <sup>c</sup>	NO	YES/NO	OCCUPIED YES = OCC signal received from space thermostat or unitary controller YES = 24 vac on terminal OCC NO = 0 vac on terminal OCC
	HEAT PUMP	N/A <sup>d</sup>	COOL HEAT	HEAT PUMP MODE Displays COOL or HEAT when system is set to heat pump (Non-conventional)
	COOL Y1—IN	OFF	ON/OFF	FIRST STAGE COOLING DEMAND (Y1-IN) Y1-I signal from space thermostat or unitary controller for cooling stage 1. ON = 24 vac on terminal Y1-I OFF = 0 vac on terminal Y1-I
	COOL Y1—OUT	OFF	ON/OFF	FIRST STAGE COOLING RELAY OUTPUT Cool stage 1 Relay Output to stage 1 mechanical cooling (Y1—OUT terminal)
	COOL Y2—IN	OFF	ON/OFF	SECOND STAGE COOLING DEMAND (Y2-IN) Y2-I signal from space thermostat or unitary controller for second stage cooling. ON = 24 vac on terminal Y2-I OFF = 0 vac on terminal Y2-I
	COOL Y2—OUT	OFF	ON/OFF	SECOND STAGE COOLING RELAY OUTPUT Cool Stage 2 Relay Output to mechanical cooling (Y2—OUT terminal)
	MA TEMP <sup>e</sup>	___ °F (or ___ °C)	-40°F to 150°F (-40°C to 66°C)	SUPPLY AIR TEMPERATURE, Cooling Mode Displays value of measured mixed air from MAT sensor. Displays ___ °F if not connected, short, or out of range.
	DA TEMP	___ °F (or ___ °C)	-40°F to 150°F (-40°C to 66°C)	DISCHARGE AIR TEMPERATURE, after Heating section Displays when Discharge Air Syk Bus sensor is connected and displays measured discharge temperature. Displays ___ °F if sensor sends invalid value, not connected, short, or out of range.
	OA TEMP	___ °F (or ___ °C)	-40°F to 140°F (-40°C to 60°C)	OUTSIDE AIR TEMP Displays measured value of outdoor air temperature. Displays ___ °F if sensor sends invalid value, short, or out of range.
	OA HUM	__ %	0 to 100%	OUTSIDE AIR RELATIVE HUMIDITY Displays measured value of outdoor humidity from OA Syk Bus sensor. Displays __ % if not connected, short, or out of range.
	RA TEMP	___ °F (or ___ °C)	0°F to 140°F (-18°C to 60°C)	RETURN AIR TEMPERATURE Displays measured value of return air temperature from RAT Syk Bus sensor. Displays ___ °F if sensor sends invalid value, not connected, short, or out of range.
	RA HUM	__ %	0 to 100%	RETURN AIR RELATIVE HUMIDITY Displays measured value of return air humidity from RA Syk Bus sensor. Displays __ % if sensor sends invalid value, not connected, short, or out of range.
	IN CO2	___ ppm	0 to 2000 ppm	SPACE/RETURN AIR CO <sub>2</sub> Displays value of measured CO <sub>2</sub> from CO <sub>2</sub> sensor. Invalid if not connected, short, or out of range. May be adjusted in Advanced menu by Zero offset and Span.
	DCV STATUS	N/A	ON/OFF	DEMAND CONTROLLED VENTILATION STATUS Displays ON if above set point and OFF if below set point, and ONLY if a CO <sub>2</sub> sensor is connected.
	DAMPER OUT	2.0-v	2.0 to 10.0-v	Displays voltage output to the damper actuator. <sup>f</sup>
	ACT POS	N/A	0 to 100%	Displays actual position of actuator.
	ACT COUNT	N/A	1 to 65,535	Displays number of times actuator has cycled. 1 cycle equals 180 degrees of actuator movement in any direction.
	ACTUATOR	N/A	OK/Alarm (on Alarm menu)	Displays ERROR if voltage or torque is below actuator range.
EXH1 OUT	OFF	ON/OFF	EXHAUST STAGE 1 RELAY OUTPUT Displays ON when damper position reaches programmed percentage set point. Output of EXH1 terminal: ON = relay closed OFF = relay open	



**Table 17 – W7220 Menu Structure<sup>a</sup> (cont)**

MENU	PARAMETER	PARAMETER DEFAULT VALUE	PARAMETER RANGE AND INCREMENT <sup>b</sup>	EXPANDED PARAMETER NAME NOTES
STATUS (cont)	EXH2 OUT	OFF	ON/OFF	EXHAUST STAGE 2 RELAY OUTPUT Output of AUX1 O terminal Displays ON when damper position reaches programmed percentage set point. ON = 24 vac output OFF = No output Displays only if AUX1 O = EXH2
	ERV	OFF	ON/OFF	ENERGY RECOVERY VENTILATOR Output of AUX1 O terminal; displays only if AUX1 O = ERV ON = 24 vac output OFF = No Output
	MECH COOL ON or HEAT STAGES ON	0	0, 1, or 2	Displays stage of mechanical cooling that is active. Displays the stage of heat pump heating that is active.
	FAN SPEED	N/A	LOW or HIGH	SUPPLY FAN SPEED Displays speed setting of fan on a 2-speed fan unit.
	W (HEAT IN)	N/A	ON/OFF	HEAT DEMAND STATUS Displays status of heat demand on a 2-speed fan unit.
SETPOINTS	MAT SET <sup>e</sup>	53°F (12°C)	38°F to 70°F (3°C to 21°C); increment by 1°F	SUPPLY AIR SETPOINT The economizer will modulate the OA damper to maintain the mixed air temperature at the set point.
	LOW T LOCK	32°F (0°C)	-45°F to 80°F (-43°C to 27°C); increment by 1°F	COMPRESSOR LOW TEMPERATURE LOCKOUT Set point determines outdoor temperature when the mechanical cooling cannot be turned on. Commonly referred to as the Compressor lockout. At or below the set point, the Y1-O and Y2-O will not be energized on the controller.
	DRYBLB SET <sup>g</sup>	63°F (17°C)	48°F to 80°F (9°C to 27°C); increment by 1°F	OA DRY BULB TEMPERATURE CHANGEOVER SETPOINT Dry bulb set point will only appear if using dry bulb changeover. Set point determines where the economizer will assume outdoor air temperature is good for free cooling; e.g.; at 63°F unit will economize at 62°F and below and not economize at 64°F and above. There is a 2°F deadband.
	ENTH CURVE	ES3	ES1,ES2,ES3,ES4, or ES5	ENTHALPY CHANGEOVER CURVE ES curve will only appear if using enthalpy changeover. Enthalpy boundary "curves" for economizing using single enthalpy. See page 57 for description of enthalpy curves.
	DCV SET	1100 ppm	500 to 2000 ppm; increment by 100	DEMAND CONTROLLED VENTILATION Displays only if CO <sub>2</sub> sensor is connected. Set point for Demand Controlled Ventilation of space. Above the set point, the OA dampers will modulate open to bring in additional OA to maintain a space ppm level below the set point.
	MIN POS	2.8-v	2 to 10 vdc	VENTILATION MINIMUM POSITION Displays ONLY if a CO <sub>2</sub> sensor is NOT connected. With 2-speed fan units, MIN POS L (low speed fan) and MIN POS H (high speed fan) settings are required. Default for MIN POS L is 3.2-v and MIN POS H is 2.8-v.
	VENTMAX	2.8-v	2 to 10 vdc	DCV MAXIMUM DAMPER POSITION Displays only if a CO <sub>2</sub> sensor is connected. Used for Vbz (ventilation maximum cfm) set point. VENTMAX is the same setting as MIN POS would be if unit did not have CO <sub>2</sub> sensor.
			100 to 9990 cfm; increment by 10	If OA, MA, RA, and CO <sub>2</sub> sensors are connected and DCV CAL ENABLE is set to AUTO mode, the OA dampers are controlled by cfm and displays from 100 to 9990 cfm.
			2 to 10 vdc	With 2-speed fan units, VENTMAX L (low speed fan) and VENTMAX H (high speed fan) settings are required. Default for VENTMAX L is 3.2-v and VENTMAX H is 2.8-v.
	VENTMIN	2.25-v	2 to 10 vdc or 100 to 9990 cfm increment by 10	DCV MINIMUM DAMPER POSITION Displays only if a CO <sub>2</sub> sensor is connected. Used for Va (ventilation min cfm) set point. This is the ventilation for less than maximum occupancy of the space.
100 to 9990 cfm; increment by 10			If OA, MA, RA, and CO <sub>2</sub> sensors are connected and DCV CAL ENABLE is set to AUTO mode, the OA dampers are controlled by cfm and displays from 100 to 9990 cfm.	
2 to 10 vdc			With 2-speed fan units VENTMIN L (low speed fan) and VENTMIN H (high speed fan) settings are required. Default for VENTMIN L is 2.5-v and VENTMIN H is 2.25-v.	
ERV OAT SP <sup>h</sup>	32°F (0°C)	0°F to 50°F (-18°C to 10°C); increment by 1°F	ENERGY RECOVERY VENTILATOR UNIT OUTDOOR AIR TEMPERATURE SETPOINT Only when AUX1 O = ERV	

**Table 17 – W7220 Menu Structure<sup>a</sup> (cont)**

MENU	PARAMETER	PARAMETER DEFAULT VALUE	PARAMETER RANGE AND INCREMENT <sup>b</sup>	EXPANDED PARAMETER NAME NOTES
SETPOINTS (cont)	EXH1 SET	50%	0 to 100%; increment by 1	EXHAUST FAN STAGE 1 SETPOINT Set point for OA damper position when exhaust fan 1 is powered by the economizer. With 2-speed fan units, Exh1 L (low speed fan) and Exh1 H (high speed fan) settings are required. Default for Exh1 L is 65% and Exh1 H is 50%.
	EXH2 SET	75%	0 to 100%; increment by 1	EXHAUST FAN STAGE 2 SETPOINT Set point for OA damper position when exhaust fan 2 is powered by the economizer. Only used when AUX1 O is set to EHX2. With 2-speed fan units, Exh2 L (low speed fan) and Exh2 H (high speed fan) settings are required. Default for Exh2 L is 80% and Exh2 H is 75%.
SYSTEM SETUP <sup>i</sup>	INSTALL	01/01/10	N/A	Display order = MM/DD/YY Setting order = DD, MM, then YY.
	UNITS DEG	°F	°F or °C	Sets economizer controller in degrees Fahrenheit or Celsius.
	EQUIPMENT	CONV	CONV or HP	CONV = conventional; HP O/B = Enable Heat Pump mode. Use AUX2 I for Heat Pump input from thermostat or controller.
	AUX2 IN	W	Shutdown (SD) Heat (W1) HP(O) HP(B)	In CONV mode: SD = Enables configuration of shutdown (default); W = Informs controller that system is in heating mode. NOTE: If using 2-speed fan mode, you must program CONV mode for W. Shutdown is not available in 2-speed fan mode. In HP O/B mode: HP(O) = energize heat pump on Cool (default); HP(B) = energize heat pump on heat.
	FAN SPEED	2 speed	1 speed/2 speed	Sets the economizer controller for operation of 1-speed or 2-speed supply fan. The controller does not control the fan, but positions the OA and RA dampers to heating or cooling mode. NOTE: 2-speed fan option also needs Heat (W1) programmed in AUX 2 In.
	FAN CFM	5000 cfm	100 to 15000 cfm; increment by 100	UNIT DESIGN AIRFLOW (cfm) Enter only if using DCVCAL ENA = AUTO. This is the capacity of the RTU. The value is found on the nameplate label for the specific unit.
	AUX1 OUT	NONE	NONE ERV EXH2 SYS	Select OUTPUT for AUX1 O relay: • NONE = not configured (output is not used) • ERV = Energy Recovery Ventilator <sup>h</sup> • EXH2 = second damper position 24 vac out for second exhaust fan • SYS = use output as an alarm signal
	OCC	INPUT	INPUT or ALWAYS	OCCUPIED MODE BY EXTERNAL SIGNAL When using a setback thermostat with occupancy out (24 vac), the 24 vac is input "INPUT" to the OCC terminal. If no occupancy output from the thermostat, then change program to "ALWAYS" OR add a jumper from terminal R to OCC terminal.
	FACTORY DEFAULT	NO	NO or YES	Resets all set points to factory defaults when set to YES. LCD will briefly flash YES and change to NO but all parameters will change to the factory default values.
ADVANCED SETUP	MA LO SET	45°F (7°C)	35°F to 65°F (2°C to 18°C); Increment by 1°F	SUPPLY AIR TEMPERATURE LOW LIMIT Temperature to activate Freeze Protection (close damper or modulate to MIN POS if temp falls below set value).
	FREEZE POS	CLO	CLO or MIN	FREEZE PROTECTION DAMPER POSITION Damper position when freeze protection is active (closed or MIN POS).
	CO2 ZERO	0 ppm	0 to 500 ppm; Increment by 10	CO <sub>2</sub> ppm level to match CO <sub>2</sub> sensor start level.
	CO2 SPAN	2000 ppm	1000 to 3000 ppm; Increment by 50	CO <sub>2</sub> ppm span to match CO <sub>2</sub> sensor, e.g.: 500-1500 sensor output would be 500 CO <sub>2</sub> zero and 1000 CO <sub>2</sub> span.
	STG3 DLY	2.0h	0 min, 5 min, 15 min, then 15 min intervals. Up to 4 hrs or OFF	COOLING STAGE 3 DELAY Delay after stage 2 cool has been active. Turns on second stage of cooling when economizer is first stage call and mechanical cooling is second stage call. Allows 3 stages of cooling, 1 economizer and 2 mechanical. OFF = no Stage 3 cooling.
	SD DMPR POS	CLO	CLO or OPN	Indicates shutdown signal from space thermostat or unitary controller. When controller receives 24 vac input on the SD terminal in conventional mode, the OA damper will open if programmed for OPN and OA damper will close if programmed for CLO. All other controls, e.g., fans, etc. will shut off.
	DA LO ALM	45°F (7°C)	NONE 35°F to 65°F (2°C to 18°C); Increment by 5°F	Used for alarm for when the DA air temperature is too low. Set lower range of alarm, below this temperature the alarm will show on the display.

**Table 17 – W7220 Menu Structure<sup>a</sup> (cont)**

MENU	PARAMETER	PARAMETER DEFAULT VALUE	PARAMETER RANGE AND INCREMENT <sup>b</sup>	EXPANDED PARAMETER NAME NOTES
ADVANCED SETUP (cont)	DA HI ALM	80°F (27°C)	NONE 70°F to 180°F (21°C to 82°C); Increment by 5°F	Used for alarm for when the DA air temperature is too high. Sets upper range of alarm; above this temperature, the alarm will show on the display.
	DCVCAL ENA	MAN	MAN (manual) AUTO	Turns on the DCV automatic control of the dampers. Resets ventilation based on the RA, OA, and MA sensor conditions. Requires all (RA, OA, MA, CO <sub>2</sub> ) sensors. This operation is not operable with a 2-speed fan unit.
	MAT T CAL	0.0°F	± 2.5°F	SUPPLY AIR TEMPERATURE CALIBRATION Allows for the operator to adjust for an out of calibration temperature sensor.
	OAS T CAL	0.0°F	± 2.5°F	OUTSIDE AIR TEMPERATURE CALIBRATION Allows for the operator to adjust for an out of calibration temperature sensor.
	OA H CAL	0% RH	±10% RH	OUTSIDE AIR HUMIDITY CALIBRATION Allows for operator to adjust for an out of calibration humidity sensor.
	RA T CAL	0.0°F	± 2.5°F	RETURN AIR TEMPERATURE CALIBRATION Allows for the operator to adjust for an out of calibration temperature sensor.
	RA H CAL	0% RH	±10% RH	RETURN AIR HUMIDITY CALIBRATION Allows for operator to adjust for an out of calibration humidity sensor.
	DA T CAL	0.0°F	± 2.5°F	DISCHARGE AIR TEMPERATURE CALIBRATION Allows for the operator to adjust for an out of calibration temperature sensor.
	2SP FAN DELAY	5 Minutes	0 to 20 minutes in 1 minute increments	TIME DELAY ON SECOND STAGE ECONOMIZING When in economizing mode, this is the delay for the high speed fan to try to satisfy the call for second stage cooling before the first stage mechanical cooling is enabled.
CHECKOUT <sup>c</sup>	DAMPER MINIMUM POSITION	N/A	N/A	The checkout for the damper minimum position is based on the system. See Table 18.
	DAMPER OPEN	N/A	N/A	Position damper to the full open position. Exhaust fan contacts enable during the DAMPER OPEN test. Make sure to pause in the mode to allow exhaust contacts to energize due to the delay in the system.
	DAMPER CLOSE	N/A	N/A	Positions damper to the fully closed position.
	CONNECT Y1-O	N/A	N/A	Closes the Y1-O relay (Y1-O).
	CONNECT Y2-O	N/A	N/A	Closes the Y2-O relay (Y2-O).
	CONNECT AUX1-O	N/A	N/A	Energizes the AUX output. If Aux setting is: • NONE — no action taken. • ERV — 24 vac out. Turns on or signals an ERV that the conditions are not good for economizing but are for ERV operation. <sup>h</sup> • SYS — 24 vac out. Issues a system alarm.
CONNECT EXH1	N/A	N/A	Closes the power exhaust fan 1 relay (EXH1).	
ALARMS	Alarms display only when they are active. The menu title "ALARMS(#)" includes the number of active alarms in parenthesis ( ). When using SYLK bus sensors, "SYLK" will appear on the screen, and when using 20k OA temperature sensors, "SENS T" will appear on the screen.			
	MA T SENS ERR	N/A	N/A	SUPPLY AIR TEMPERATURE SENSOR ERROR Mixed air sensor has failed or become disconnected — check wiring, then replace sensor if the alarm continues.
	CO2 SENS ERR	N/A	N/A	CO <sub>2</sub> SENSOR ERROR CO <sub>2</sub> sensor has failed, gone out of range or become disconnected — check wiring then replace sensor if the alarm continues.
	OA SYLK T ERR	N/A	N/A	OUTSIDE AIR S-BUS SENSOR ERROR Outdoor air enthalpy sensor has failed or become disconnected — check wiring, then replace sensor if the alarm continues.
	OA SYLK H ERR	N/A	N/A	
	RA SYLK T ERR	N/A	N/A	RETURN AIR S-BUS SENSOR ERROR Return air enthalpy sensor has failed or become disconnected — check wiring, then replace sensor if the alarm continues.
	RA SYLK H ERR	N/A	N/A	
	DA SYLK T ERR	N/A	N/A	DISCHARGE AIR S-BUS SENSOR ERROR Discharge air sensor has failed or become disconnected — check wiring, then replace sensor if the alarm continues.
	OA SENS T ERR	N/A	N/A	OUTSIDE AIR TEMPERATURE SENSOR ERROR Outdoor air temperature sensor has failed or become disconnected — check wiring, then replace if the alarm continues.
ACT ERROR	N/A	N/A	ACTUATOR ERROR Actuator has failed or become disconnected — check for stall, over voltage, under voltage and actuator count. Replace actuator if damper is movable and supply voltage is between 21.6-v and 26.4-v. Check actuator count on STATUS menu.	

**Table 17 — W7220 Menu Structure<sup>a</sup> (cont)**

MENU	PARAMETER	PARAMETER DEFAULT VALUE	PARAMETER RANGE AND INCREMENT <sup>b</sup>	EXPANDED PARAMETER NAME NOTES
<b>ALARMS (cont)</b>	FREEZE ALARM	N/A	N/A	Check if outdoor temperature is below the LOW Temp Lockout on set point menu. Check if Mixed air temperature on STATUS menu is below the Low Set point on Advanced menu. When conditions are back in normal range, the alarm will go away.
	SHUTDOWN ACTIVE	N/A	N/A	AUX2 IN is programmed for SHUTDOWN and 24-v has been applied to AUX2 IN terminal.
	DMP CAL RUNNING	N/A	N/A	<b>DAMPER CALIBRATION ROUTINE RUNNING</b> If DCV Auto enable has been programmed, this alarm will display when the W7220 is completing a calibration on the dampers. Wait until the calibration is completed and the alarm will go away. Must have OA, MA and RA sensors for DCV calibration; set up is in the Advanced setup menu.
	DA SENS ALM	N/A	N/A	<b>DISCHARGE AIR TEMPERATURE SENSOR ALARM</b> Discharge air temperature is out of the range set in the ADVANCED SETUP Menu. Check the temperature of the discharge air.
	SYS ALARM	N/A	N/A	When AUX1-O is set to SYS and there is any alarm (e.g., failed sensors, etc.), the AUX1-O terminal has 24 vac out.
	ACT UNDER V	N/A	N/A	<b>ACTUATOR VOLTAGE LOW</b> Voltage received by actuator is above expected range.
	ACT OVER V	N/A	N/A	<b>ACTUATOR VOLTAGE HIGH</b> Voltage received by actuator is below expected range.
	ACT STALLED	N/A	N/A	<b>ACTUATOR STALLED</b> Actuator stopped before achieving commanded position.

NOTE(S):

- This table illustrates the complete hierarchy. Your menu parameters may be different depending on your configuration. For example, if you do not have a DCV (CO<sub>2</sub>) sensor, then none of the DCV parameters appear.
- When values are displayed, pressing and holding the ▲ or ▼ button causes the display to automatically increment.
- STATUS → OCCUPIED — The factory-standard Occupancy signal originates with a thermostat or other controller call for indoor fan operation at CTB terminal G. This signal passes through the Central Terminal Board's OCCUPANCY jumper to the ECONO connector and to the W7220's OCC input terminal. An external timeclock or relay is required to implement an Occupancy schedule on the economizer damper position.
- N/A = Not Applicable.
- STATUS → MA TEMP, SETPOINTS → MAT SET — The W7220 menu parameters and labels include designations MA, MAT and Mixed Air for the economizer cooling control sensor. On these rooftop units, the economizer control sensor is located downstream of the evaporator/indoor coil in the supply fan section where this sensor is designated as Supply Air Temperature (SAT) sensor.
- After 10 minutes without a command or mode change, the controller will change to normal operation.
- SETPOINTS → DRYBLB SET — This point is not displayed if a Return Air (differential) temperature sensor or an Outdoor Air enthalpy sensor is connected.
- ERV Operation: When in cooling mode AND the conditions are NOT OK for economizing — the ERV terminal will be energized. In the Heating mode, the ERV terminal will be energized when the OA is below the ERV OAT set point in the set point menu.
- SYSTEM SETUP parameters must be configured as noted for 2-Speed unit operation:  
EQUIPMENT = CONV  
AUX2 I = W  
FAN SPEED = 2SPEED

LEGEND

- CLO** — Compressor Lockout
- ERV** — Energy Recovery Ventilator
- LCD** — Liquid Crystal Display
- MA** — Mixed Air
- MAT** — Mixed Air Temperature
- N/A** — Not Applicable
- OA** — Outdoor Air
- OAT** — Outdoor Air Temperature
- OCC** — Occupied
- RA** — Return Air
- RAT** — Return Air Temperature
- RTU** — Rooftop Unit
- SYS** — System

For damper minimum position settings and checkout menu readings, see Table 18. For dry bulb operation with a one-speed fan, with or without DCV, see Tables 19 and 20. For enthalpy operation with a one-speed fan, with or without DCV see Tables 21 and 22. For dry bulb operation with a 2-speed indoor fan, with or without DCV, see Tables 23 and 24. For enthalpy operation with a 2-speed indoor fan, with or without DCV, see Tables 25 and 26.



**Table 18 – Damper Minimum Position Settings and Readings on Checkout Menu**

DEMAND CONTROLLED VENTILATION (CO <sub>2</sub> SENSOR)	FAN SPEED	SETPOINTS	CHECKOUT
NO	1	MIN POS	VMAX-HS
		N/A	N/A
	2	MIN POS H	VMAX-HS
MIN POS L		VMAX-LS	
YES	1	VENT MIN	VMAX-HS
		VENT MAX	VMAX-HS
	2	VENT MIN H	VMAX-HS
		VENT MAX H	VMAX-LS
		VENT MIN L	N/A
		VENT MAX L	N/A

**Table 19 – Dry Bulb Operation without DCV (CO<sub>2</sub> Sensor) – One-Speed Fan**

DEMAND CONTROLLED VENTILATION (DCV)	OUTSIDE AIR GOOD TO ECONOMIZE	Y1-I	Y2-I	FAN SPEED	Y1-O	Y2-O	OCCUPIED	UNOCCUPIED
NONE	No	Off	Off	High	0-v/Off	0-v/Off	MIN POS	Closed
		On	Off	High	24-v/On	0-v/Off	MIN POS	Closed
		On	On	High	24-v/On	24-v/On	MIN POS	Closed
	Yes	Off	Off	High	0-v/Off	0-v/Off	MIN POS	Closed
		On	Off	High	0-v/Off	0-v/Off	MIN POS to Full-Open	Closed to Full-Open
		On	On	High	24-v/On	0-v/Off <sup>a</sup>	MIN POS to Full-Open	Closed to Full-Open

NOTE(S):

- a. With stage 3 delay (STG3 DLY) in Advanced setup menu can turn on second stage of mechanical cooling Y2-O after the delay if the call for Y-I and Y2-I have not been satisfied.

**Table 20 – Dry Bulb Operation with DCV (CO<sub>2</sub> Sensor) – One-Speed Fan**

DEMAND CONTROLLED VENTILATION (DCV)	OUTSIDE AIR GOOD TO ECONOMIZE	Y1-I	Y2-I	FAN SPEED	Y1-O	Y2-O	OCCUPIED	UNOCCUPIED
Below CO <sub>2</sub> set	No	Off	Off	High	0-v/Off	0-v/Off	VENTMIN	Closed
		On	Off	High	24-v/On	0-v/Off	VENTMIN	Closed
		On	On	High	24-v/On	24-v/On	VENTMIN	Closed
	Yes	Off	Off	High	0-v/Off	0-v/Off	VENTMIN	Closed
		On	Off	High	0-v/Off	0-v/Off	VENTMIN to Full-Open	Closed to Full-Open
		On	On	High	24-v/On	0-v/Off <sup>a</sup>	VENTMIN to Full-Open	Closed to Full-Open
Above CO <sub>2</sub> set	No	Off	Off	High	0-v/Off	0-v/Off	VENTMIN to VENTMAX	Closed
		On	Off	High	24-v/On	0-v/Off	VENTMIN to VENTMAX	Closed
		On	On	High	24-v/On	24-v/On	VENTMIN to VENTMAX	Closed
	Yes	Off	Off	High	0-v/Off	0-v/Off	VENTMIN to VENTMAX	Closed
		On	Off	High	0-v/Off	0-v/Off	VENTMIN to Full-Open	Closed to Full-Open
		On	On	High	24-v/On	0-v/Off <sup>a</sup>	VENTMIN to Full-Open	Closed to Full-Open

NOTE(S):

- a. With stage 3 delay (STG3 DLY) in Advanced setup menu can turn on second stage of mechanical cooling Y2-O after the delay if the call for Y-I and Y2-I have not been satisfied.

**Table 21 – Enthalpy Operation without DCV (CO<sub>2</sub> Sensor) – One-Speed Fan**

DEMAND CONTROLLED VENTILATION (DCV)	OUTSIDE AIR GOOD TO ECONOMIZE	Y1-I	Y2-I	FAN SPEED	Y1-O	Y2-O	OCCUPIED	UNOCCUPIED
NONE	No	Off	Off	High	0-v/Off	0-v/Off	MIN POS	Closed
		On	Off	High	24-v/On	0-v/Off	MIN POS	Closed
		On	On	High	24-v/On	24-v/On	MIN POS	Closed
	Yes	Off	Off	High	0-v/Off	0-v/Off	MIN POS	Closed
		On	Off	High	0-v/Off	0-v/Off	MIN POS to Full-Open	Closed to Full-Open
		On	On	High	24-v/On	0-v/Off <sup>a</sup>	MIN POS to Full-Open	Closed to Full-Open

NOTE(S):

- a. With stage 3 delay (STG3 DLY) in Advanced setup menu can turn on second stage of mechanical cooling Y2-O after the delay if the call for Y-I and Y2-I have not been satisfied.

**Table 22 – Enthalpy Operation with DCV (CO<sub>2</sub> Sensor) – One-Speed Fan**

DEMAND CONTROLLED VENTILATION (DCV)	OUTSIDE AIR GOOD TO ECONOMIZE	Y1-I	Y2-I	FAN SPEED	Y1-O	Y2-O	OCCUPIED	UNOCCUPIED
Below CO <sub>2</sub> set	No	Off	Off	High	0-v/Off	0-v/Off	VENTMIN	Closed
		On	Off	High	24-v/On	0-v/Off	VENTMIN	Closed
		On	On	High	24-v/On	24-v/On	VENTMIN	Closed
	Yes	Off	Off	High	0-v/Off	0-v/Off	VENTMIN	Closed
		On	Off	High	0-v/Off	0-v/Off	VENTMIN to Full-Open	Closed to Full-Open
		On	On	High	24-v/On	0-v/Off†	VENTMIN to Full-Open	Closed to Full-Open
Above CO <sub>2</sub> set	No	Off	Off	High	0-v/Off	0-v/Off	VENTMIN to VENTMAX	Closed
		On	Off	High	24-v/On	0-v/Off	VENTMIN L to VENTMAX	Closed
		On	On	High	24-v/On	24-v/On	VENTMIN H to VENTMAX	Closed
	Yes	Off	Off	High	0-v/Off	0-v/Off	VENTMIN L to VENTMAX	Closed
		On	Off	High	0-v/Off	0-v/Off	VENTMIN to Full-Open	Closed to Full-Open
		On	On	High	DELAY <sup>a</sup> 24-v/On	0-v/Off <sup>b</sup>	VENTMIN to Full-Open	Closed to Full-Open

NOTE(S):

- a. With 2SP FAN DELAY (Advanced Setup Menu) when in the economizing mode there is a delay for the high speed fan to try to satisfy the call for second stage cooling by turning on the fan to high and opening the OA damper 100% before the first stage mechanical cooling is enabled.  
 b. With stage 3 delay (STG3 DLY) in Advanced setup menu can turn on second stage of mechanical cooling Y2-O after the delay if the call for Y-I and Y2-I have not been satisfied.

**Table 23 – Dry Bulb Operation without DCV (CO<sub>2</sub> Sensor) – Two-Speed Fan**

DEMAND CONTROLLED VENTILATION (DCV)	OUTSIDE AIR GOOD TO ECONOMIZE	Y1-I	Y2-I	FAN SPEED	Y1-O	Y2-O	OCCUPIED	UNOCCUPIED
NONE	No	Off	Off	Low	0-v/Off	0-v/Off	MIN POS L	Closed
		On	Off	Low	24-v/On	0-v/Off	MIN POS L	Closed
		On	On	High	24-v/On	24-v/On	MIN POS H	Closed
NONE	Yes	Off	Off	Low	0-v/Off	0-v/Off	MIN POS L	Closed
		On	Off	Low	0-v/Off	0-v/Off	MIN POS L to Full-Open	Closed to Full-Open
		On	On	High	DELAY <sup>a</sup> 24-v/On	0-v/Off <sup>b</sup>	MIN POS H to Full-Open	Closed to Full-Open

NOTE(S):

- a. With 2SP FAN DELAY (Advanced Setup Menu) when in the economizing mode there is a delay for the high speed fan to try to satisfy the call for second stage cooling by turning on the fan to high and opening the OA damper 100% before the first stage mechanical cooling is enabled.  
 b. With stage 3 delay (STG3 DLY) in Advanced setup menu can turn on second stage of mechanical cooling Y2-O after the delay if the call for Y-I and Y2-I have not been satisfied.

**Table 24 – Dry Bulb Operation with DCV (CO<sub>2</sub> Sensor) – Two-Speed Fan**

DEMAND CONTROLLED VENTILATION (DCV)	OUTSIDE AIR GOOD TO ECONOMIZE	Y1-I	Y2-I	FAN SPEED	Y1-O	Y2-O	OCCUPIED	UNOCCUPIED
Below CO <sub>2</sub> Set	No	OFF	OFF	LOW	0-v/Off	0-v/Off	VENTMIN	Closed
		ON	OFF	LOW	24-v/On	0-v/Off	VENTMIN	Closed
		ON	ON	HIGH	24-v/On	24-v/On	VENTMIN	Closed
	Yes	OFF	OFF	LOW	0-v/Off	0-v/Off	VENTMIN	Closed
		ON	OFF	LOW	0-v/Off	0-v/Off	VENTMIN to Full-Open	Closed to Full-Open
		ON	ON	HIGH	24-v/On	0-v/Off	VENTMIN to Full-Open	Closed to Full-Open
Above CO <sub>2</sub> Set	No	OFF	OFF	LOW	0-v/Off	0-v/Off	VENTMIN to VENTMAX	Closed
		ON	OFF	LOW	24-v/On	0-v/Off	VENTMIN to VENTMAX	Closed
		ON	ON	HIGH	24-v/On	24-v/On	VENTMIN to VENTMAX	Closed
	Yes	OFF	OFF	LOW	0-v/Off	0-v/Off	VENTMIN to VENTMAX	Closed
		ON	OFF	LOW	0-v/Off	0-v/Off	VENTMIN to Full-Open	Closed to Full-Open
		ON	ON	HIGH	DELAY <sup>a</sup> 24-v/On	0-v/Off <sup>b</sup>	VENTMIN to Full-Open	Closed to Full-Open

NOTE(S):

- With 2SP FAN DELAY (Advanced Setup Menu) when in the economizing mode there is a delay for the high speed fan to try to satisfy the call for second stage cooling by turning on the fan to high and opening the OA damper 100% before the first stage mechanical cooling is enabled.
- With stage 3 delay (STG3 DLY) in Advanced setup menu can turn on second stage of mechanical cooling Y2-O after the delay if the call for Y1-I and Y2-I have not been satisfied.

**Table 25 – Enthalpy Operation without DCV (CO<sub>2</sub> Sensor) – Two-Speed Fan**

DEMAND CONTROLLED VENTILATION (DCV)	OUTSIDE AIR GOOD TO ECONOMIZE	Y1-I	Y2-I	FAN SPEED	Y1-O	Y2-O	OCCUPIED	UNOCCUPIED
NO CO <sub>2</sub> SENSOR	NO	OFF	OFF	LOW	0-v/Off	0-v/Off	MIN POS	Closed
		ON	OFF	LOW	24-v/On	0-v/Off	MIN POS	Closed
		ON	ON	HIGH	24-v/On	24-v/On	MIN POS	Closed
	YES	OFF	OFF	LOW	0-v/Off	0-v/Off	MIN POS	Closed
		ON	OFF	LOW	0-v/Off	0-v/Off	MIN POS to Full Open	Closed to Full-Open
		ON	ON	HIGH	DELAY <sup>a</sup> 24-v/On	0-v/Off <sup>b</sup>	MIN POS to Full Open	Closed to Full-Open

NOTE(S):

- With 2SP FAN DELAY (Advanced Setup Menu) when in the economizing mode there is a delay for the high speed fan to try to satisfy the call for second stage cooling by turning on the fan to high and opening the OA damper 100% before the first stage mechanical cooling is enabled.
- With stage 3 delay (STG3 DLY) in Advanced setup menu can turn on second stage of mechanical cooling Y2-O after the delay if the call for Y1-I and Y2-I have not been satisfied.

**Table 26 – Enthalpy Operation with DCV (CO<sub>2</sub> Sensor) – Two-Speed Fan**

DEMAND CONTROLLED VENTILATION (DCV)	OUTSIDE AIR GOOD TO ECONOMIZE	Y1-I	Y2-I	FAN SPEED	Y1-O	Y2-O	OCCUPIED	UNOCCUPIED
<b>Below CO<sub>2</sub> Set</b>	No	OFF	OFF	LOW	0-v/Off	0-v/Off	VENTMIN	Closed
		ON	OFF	LOW	24-v/On	0-v/Off	VENTMIN	Closed
		ON	ON	HIGH	24-v/On	24-v/On	VENTMIN	Closed
	Yes	OFF	OFF	LOW	0-v/Off	0-v/Off	VENTMIN	Closed
		ON	OFF	LOW	0-v/Off	0-v/Off	VENTMIN to Full-Open	Closed to Full-Open
		ON	ON	HIGH	24-v/On	0-v/Off	VENTMIN to Full-Open	Closed to Full-Open
<b>Above CO<sub>2</sub> Set</b>	No	OFF	OFF	LOW	0-v/Off	0-v/Off	VENTMIN to VENTMAX	Closed
		ON	OFF	LOW	24-v/On	0-v/Off	VENTMIN to VENTMAX	Closed
		ON	ON	HIGH	24-v/On	24-v/On	VENTMIN to VENTMAX	Closed
	Yes	OFF	OFF	LOW	0-v/Off	0-v/Off	VENTMIN to VENTMAX	Closed
		ON	OFF	LOW	0-v/Off	0-v/Off	VENTMIN to Full-Open	Closed to Full-Open
		ON	ON	HIGH	DELAY <sup>a</sup> 24-v/On	0-v/Off <sup>b</sup>	VENTMIN to Full-Open	Closed to Full-Open

NOTE(S):

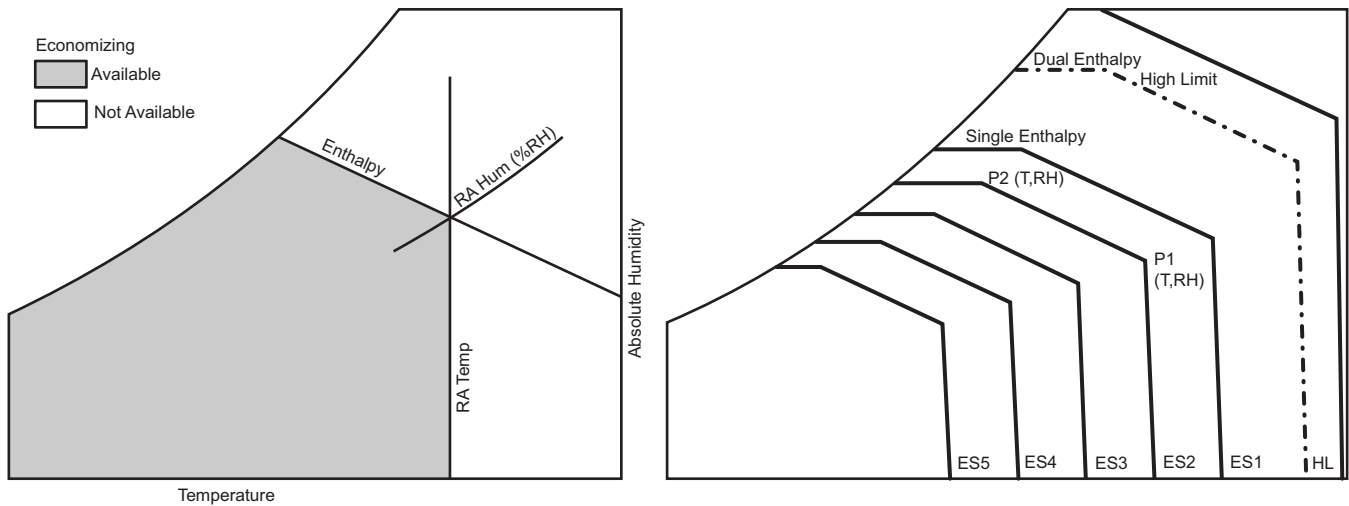
- With 2SP FAN DELAY (Advanced Setup Menu) when in the economizing mode there is a delay for the high speed fan to try to satisfy the call for second stage cooling by turning on the fan to high and opening the OA damper 100% before the first stage mechanical cooling is enabled.
- With stage 3 delay (STG3 DLY) in Advanced setup menu can turn on second stage of mechanical cooling Y2-O after the delay if the call for Y1-I and Y2-I have not been satisfied.

#### ENTHALPY SETTINGS

When the OA temperature, enthalpy and dew point are below the respective set points, the Outdoor Air can be used for economizing. Figure 75 shows the new single enthalpy boundaries in the W7220. There are 5 boundaries (set points ES1 through ES5), which are defined by dry bulb temperature, enthalpy and dew point.

Refer to Table 27 for ENTH CURVE set point values.





**Fig. 75 – Single Enthalpy Curve Boundaries**

**Table 27 – Single Enthalpy and Dual Enthalpy High Limit Curves**

ENTHALPY CURVE	TEMP. DRY BULB (°F)	TEMP. DEWPOINT (°F)	ENTHALPY (btu/lb/da)	POINT P1		POINT P2	
				TEMP. (°F)	HUMIDITY (%RH)	TEMP. (°F)	HUMIDITY (%RH)
ES1	80	60	28.0	80	36.8	66.3	80.1
ES2	75	57	26.0	75	39.6	63.3	80.0
ES3	70	54	24.0	70	42.3	59.7	81.4
ES4	65	51	22.0	65	44.8	55.7	84.2
ES5	60	48	20.0	60	46.9	51.3	88.5
HL	86	66	32.4	86	38.9	72.4	80.3

The W7220 calculates the enthalpy and dew point using the OA temperature and humidity input from the OA enthalpy sensor. When the OA temperature, OA humidity and OA dew point are all below the selected boundary, the economizer sets the economizing mode to YES, economizing is available.

When all of the OA conditions are above the selected boundary, the conditions are not good to economize and the mode is set to NO.

Figure 75 shows the 5 current boundaries. There is also a high limit boundary for differential enthalpy. The high limit boundary is ES1 when there are no stages of mechanical cooling energized and HL (high limit) when a compressor stage is energized.

**TWO-SPEED FAN OPERATION**

NOTE: Two-Speed Fan operation applies to size 07 models only.

The W7220 controller has the capability to work with a system using a 2-speed supply fan. The W7220 does not control the supply directly but uses the following input status to determine the speed of the supply fan and controls the OA damper to the required position, see Table 28.

**Table 28 – Fan Speed**

STATE	FAN SPEED
OCC	Low
Y1	Low
Y2	High
W	High

The W (heating mode) is not controlled by the W7220 but it requires the status to know where to position the OA damper for minimum position for the fan speed.

The 2-speed fan delay is available when the system is programmed for 2-speed fan (in the System Setup menu item). The 2-speed fan delay is defaulted to 5 minutes and can be changed in

the Advanced Setup menu item. When the unit has a call for Y1 In and in the free cooling mode and there is a call for Y2 In, the 2-speed fan delay starts and the OA damper will modulate 100% open, the supply fan should be set to high speed by the unit controller.

After the delay one of 2 actions will happen:

- The Y2 In call will be satisfied with the damper 100% open and fan on high speed and the call will turn off
- OR
- If the call for additional cooling in the space has not been satisfied then the first stage of mechanical cooling will be enabled through Y1 Out.

**CHECKOUT**

Inspect all wiring connections at the economizer module’s terminals, and verify compliance with the installation wiring diagrams. For checkout, review the Status of each configured parameter and perform the Checkout tests.

NOTE: For information about menu navigation and use of the keypad, see Interface Overview on page 47.

**Power Up**

After the W7220 module is mounted and wired, apply power.

**Initial Menu Display**

On initial start up, Honeywell displays on the first line and economizer W7220 on the second line. After a brief pause, the revision of the software appears on the first line and the second line will be blank.

**Power Loss (Outage or Brownout)**

All set points and advanced settings are restored after any power loss or interruption.

NOTE: All settings are stored in non-volatile flash memory.

### Status

Use the Status menu (see Table 17) to check the parameter values for the various devices and sensors configured.

NOTE: For information about menu navigation and use of the keypad, see Interface Overview on page 47.

### Checkout Tests

Use the Checkout menu (see page 51) to test the damper operation and any configured outputs. Only items that are configured are shown in the Checkout menu.

NOTE: For information about menu navigation and use of the keypad, see Interface Overview on page 47.

To perform a Checkout test:

1. Scroll to the desired test in the Checkout menu using the ▲ and ▼ buttons.
2. Press the ↵ (Enter) button to select the item. RUN? appears.
3. Press the ↵ (Enter) button to start the test. The unit pauses and then displays IN PROGRESS. When the test is complete, DONE appears.
4. When all desired parameters have been tested, press the ⏴ (Menu Up) button to end the test.

The Checkout tests can all be performed at the time of installation or at any time during the operation of the system as a test that the system is operable.

**⚠ CAUTION**

**EQUIPMENT DAMAGE HAZARD**  
Failure to follow this caution may result in equipment damage.  
Be sure to allow enough time for compressor start-up and shut-down between checkout tests so that you do not short-cycle the compressors.

### TROUBLESHOOTING

#### Alarms

The economizer module provides alarm messages that display on the 2-line LCD.

NOTE: Upon power up, the module waits 60 minutes before checking for alarms. This allows time for all the configured devices (e.g. sensors, actuator) to become operational. The exception is the SAT sensor which will alarm immediately.

If one or more alarms are present and there has been no keypad activity for at least 5 minutes, the Alarms menu displays and cycles through the active alarms.

You can also navigate to the Alarms menu at any time.

#### Clearing Alarms

Once the alarm has been identified and the cause has been removed (e.g. replaced faulty sensor) the alarm can be cleared from the display.

To clear an alarm, perform the following:

1. Navigate to the desired alarm.
2. Press the ↵ (Enter) button. ERASE? displays.
3. Press the ↵ (Enter) button. ALARM ERASED displays.

4. Press the ⏴ (Menu up/Exit) button to complete the action and return to the previous menu.

NOTE: If the alarm still exists after clearing it, it is redisplayed within 5 seconds.

## PRE-START-UP/START-UP

**⚠ WARNING**

**PERSONAL INJURY HAZARD**  
Failure to follow this warning could result in personal injury or death.

1. Follow recognized safety practices and wear approved Personal Protective Equipment (PPE), including safety glasses and gloves when checking or servicing refrigerant system.
2. Do not use a torch to remove any component. System contains oil and refrigerant under pressure. To remove a component, wear PPE and proceed as follows:
  - a. Shut off all electrical power to unit. Apply applicable lockout/tag-out procedures.
  - b. Recover refrigerant to relieve all pressure from system using both high-pressure and low pressure ports.
  - c. Do not use a torch. Cut component connection tubing with tubing cutter and remove component from unit.
  - d. Carefully un-sweat remaining tubing stubs when necessary. Oil can ignite when exposed to torch flame.
3. Do not operate compressor or provide any electric power to unit unless compressor terminal cover is in place and secured.
4. Do not remove compressor terminal cover until all electrical power is disconnected and approved lock-out/tag-out procedures are in place.
5. Relieve all pressure from system before touching or disturbing anything inside terminal box whenever refrigerant leak is suspected around compressor terminals.
6. Never attempt to repair a soldered connection while refrigerant system is under pressure.

**⚠ WARNING**

**ELECTRICAL OPERATION HAZARD**  
Failure to follow this warning could result in personal injury or death.  
The unit must be electrically grounded in accordance with local codes and NEC ANSI/NFPA 70 (American National Standards Institute/National Fire Protection Association).

Proceed as follows to inspect and prepare the unit for initial start-up:

1. Remove all access panels.
2. Read and follow instructions on all WARNING, CAUTION, and INFORMATION labels attached to, or shipped with, unit.

3. Make the following inspections:
  - a. Inspect for shipping and handling damages such as broken lines, loose parts, or disconnected wires, etc.
  - b. Inspect for oil at all refrigerant tubing connections and on unit base. Detecting oil generally indicates a refrigerant leak. Leak-test all refrigerant tubing connections using electronic leak detector, halide torch, or liquid-soap solution.
  - c. Inspect all field-wiring and factory-wiring connections. Be sure that connections are completed and tight. Be sure that wires are not in contact with refrigerant tubing or sharp edges.
  - d. Inspect coil fins. If damaged during shipping and handling, carefully straighten fins with a fin comb.
4. Verify the following conditions:
  - a. Make sure that condenser-fan blade are correctly positioned in fan orifice. See Condenser Fan Adjustment section for more details.
  - b. Make sure that air filter(s) is in place.
  - c. Make sure that condensate drain trap is filled with water to ensure proper drainage.
  - d. Make sure that all tools and miscellaneous loose parts have been removed.

## START-UP, GENERAL

### Unit Preparation

Make sure that unit has been installed in accordance with installation instructions and applicable codes.

In addition to the base unit start-up (unit with electro-mechanical control), there are a few steps needed to properly start-up units with optional direct digital controls (DDC). The DDC's Service Test function should be used to assist in the base unit start-up and also allows verification of output operation. Controller configuration is also part of start-up. This is especially important when field accessories have been added to the unit. The factory pre-configures options installed at the factory. There may also be additional installation steps or inspection required during the start-up process.

### Additional Installation/Inspection

Inspect the field-installed accessories for proper installation, making note of which ones do or do not require configuration changes. Inspect the DDC Alarms for initial insight to any potential issues. Refer to the Controls, Start-up, Operation and Troubleshooting Instructions manual for the specific DDC. Inspect the SAT sensor for relocation as intended during installation. Inspect special wiring as directed below.

### Return-Air Filters

Ensure correct filters are installed in unit. (See "PHYSICAL DATA" on page 62.). Do not operate unit without return-air filters.

### Outdoor-Air Inlet Screens

Outdoor-air inlet screen must be in place before operating unit.

### Compressor Mounting

Compressors are internally spring mounted. Do not loosen or remove compressor hold down bolts.

### Internal Wiring

Check all electrical connections in unit control boxes. Tighten as required.

### Refrigerant Service Ports

Each unit system has two 1/4 in. SAE flare (with check valves) service ports: one on the suction line, and one on the compressor discharge line. Be sure that caps on the ports are tight.

### Compressor Rotation

#### ⚠ CAUTION

#### EQUIPMENT DAMAGE HAZARD

Failure to follow this caution can result in premature wear and damage to equipment.

Scroll compressors can only compress refrigerant if rotating in the right direction. Reverse rotation for extended times can result in internal damage to the compressor. Scroll compressors are sealed units and cannot be repaired on site location.

On 3-phase units with scroll compressors, it is important to be certain compressor is rotating in the proper direction. To determine whether or not compressor is rotating in the proper direction:

1. Connect service gauges to suction and discharge pressure fittings.
2. Energize the compressor.
3. The suction pressure should drop and the discharge pressure should rise, as is normal on any start-up.

If the suction pressure does not drop and the discharge pressure does not rise to normal levels:

1. Note that the evaporator fan is probably also rotating in the wrong direction.
2. Turn off power to the unit and install lockout tag.
3. Reverse any 2 of the unit power leads.
4. Re-energize to the compressor. Check pressures.

The suction and discharge pressure levels should now move to their normal start-up levels.

NOTE: When the compressor is rotating in the wrong direction, the unit will make an elevated level of noise and will not provide cooling.

### Refrigerant Service Ports

Each system has two 1/4 in. SAE flare (with check valves) service ports: one on the suction line, and one on the compressor discharge line. Be sure that caps on the ports are tight.

### Cooling

Set space thermostat to OFF position. To start unit, turn on main power supply. Set system selector switch at COOL position and fan switch at AUTO. position. Adjust thermostat to a setting below room temperature. Compressor starts on closure of contactor.

Check unit charge. Refer to Refrigerant Charge section on page 16.

Reset thermostat at a position above room temperature. Compressor will shut off. Evaporator fan will shut off after a 30-second delay.

To shut off unit, set system selector switch at OFF position. Resetting thermostat at a position above room temperature shuts unit off temporarily until space temperature exceeds thermostat setting.

## Heating

To start unit, turn on main power supply. Set system selector switch to the HEAT position and set thermostat at a setting above room temperature. Set fan to AUTO position.

First stage of thermostat energizes the first stage of the electric heaters. Second stage of thermostat energizes the second stage of electric heaters (if installed). Check heating effects at air supply grille(s).

If electric heaters do not energize, reset limit switch (located on supply-fan scroll) by pressing button located between terminals on the switch.

To shut unit off, set system selector switch to the OFF position. Resetting thermostat at a position below room temperature temporarily shuts unit off until space temperature falls below thermostat setting.

## Ventilation (Continuous Fan)

Set fan and system selector switches at ON and OFF positions, respectively. Evaporator fan operates continuously to provide constant air circulation.

## FASTENER TORQUE VALUES

Heat shield screws	30 in.-lb (3.4 Nm) ±2 in.-lb (0.2 Nm)
Stator motor mounting screws	23 in.-lb (2.6 Nm) ±2 in.-lb (0.2 Nm)
Fan rotor mounting screws	23 in.-lb (2.6 Nm) ±2 in.-lb (0.2 Nm)
Limit switch screws	50 in.-lb (5.7 Nm) ±5 in.-lb (0.6 Nm)
Fan Deck bracket screws	50 in.-lb (5.7 Nm) ±5 in.-lb (0.6 Nm)
Condenser fan motor mounting screws	30 in.-lb (3.4 Nm) ±3 in.-lb (0.3 Nm)
Condenser fan hub set screw	60 in.-lb (6.8 Nm) ±5 in.-lb (0.6 Nm)
Compressor mounting bolts	65 in.-lb (7.3 Nm) +10 in.-lb (1.2 Nm)

## START-UP, RTU OPEN CONTROLS

### IMPORTANT: SET-UP INSTRUCTIONS

Installation, wiring and troubleshooting information for the RTU Open Controller.: “RTU Open Multi-Protocol Controller Factory-Installed Option — Controls, Start-up, Operation and Troubleshooting Instructions.” Have a copy of this manual available at unit start-up.

## START-UP, SYSTEMVU CONTROLS

### IMPORTANT: SET-UP INSTRUCTIONS

Installation, wiring and troubleshooting information for the SystemVu™ Controller.: “50FCQ 04-07, 50GCQ 04-06 Single Package Rooftop Units with SystemVu Controls Version X.X Controls, Start-up, Operation and Troubleshooting.” Have a copy of this manual available at unit start-up.



## APPENDIX A — MODEL NUMBER NOMENCLATURE

Position:	1	2	3	4	5	6	7	8	9	10	11	12	13	14	15	16	17	18
Example:	5	0	F	C	Q	A	0	4	A	2	A	5	-	0	A	0	A	0

### Unit/Series/Model

50FCQ – Packaged Rooftop Heat Pump  
 14.3 SEER Standard Efficiency, sizes 04-06  
 13.4 SEER2 Standard Efficiency, sizes 04-06  
 15.0 IEER Standard Efficiency, size 07

### Refrig. Systems Options

A = Standard One Stage Cooling Models<sup>1,2</sup>  
 C = Standard One Stage Cooling Models, 1-phase voltage (size 05 only)<sup>3</sup>  
 M = Single Circuit, Two Stage Cooling Models<sup>4</sup>

### Cooling Tons

04 = 3 tons  
 05 = 4 tons  
 06 = 5 tons  
 07 = 6 tons

### Sensor Options

A = None  
 B = Return Air (RA) Smoke Detector  
 C = Supply Air (SA) Smoke Detector  
 D = RA + SA Smoke Detector  
 E = CO<sub>2</sub> Sensor  
 F = RA Smoke Detector and CO<sub>2</sub> Sensor  
 G = SA Smoke Detector and CO<sub>2</sub> Sensor  
 H = RA + SA Smoke Detector and CO<sub>2</sub> Sensor  
 J = Condensate Overflow Switch (Electromechanical controls only)  
 K = Condensate Overflow Switch and RA Smoke Detector  
 L = Condensate Overflow Switch and RA and SA Smoke Detectors  
 M = Condensate Overflow Switch and SA Smoke Detector

### Indoor Fan Options

1 = Direct Drive – EcoBlue – Standard Static  
 2 = Direct Drive – EcoBlue – Medium Static  
 3 = Direct Drive – EcoBlue – High Static

### Coil Options – (Outdoor - Indoor — Hail Guard)

A = Al/Cu - Al/Cu  
 B = Precoat Al/Cu - Al/Cu  
 C = E-coat Al/Cu - Al/Cu  
 D = E-coat Al/Cu - E-coat Al/Cu  
 E = Cu/Cu - Al/Cu  
 F = Cu/Cu - Cu/Cu  
 M = Al/Cu - Al/Cu — Louvered Hail Guard  
 N = Precoat Al/Cu - Al/Cu — Louvered Hail Guard  
 P = E-coat Al/Cu - Al/Cu — Louvered Hail Guard  
 Q = E-coat Al/Cu - E-coat Al/Cu — Louvered Hail Guard  
 R = Cu/Cu - Al/Cu — Louvered Hail Guard  
 S = Cu/Cu - Cu/Cu — Louvered Hail Guard

### Voltage

1 = 575-3-60  
 3 = 208/230-1-60<sup>1,5</sup>  
 5 = 208/230-3-60  
 6 = 460-3-60

### Packaging & Seismic Compliance

0 = Standard  
 1 = LTL

### Electrical Options

A = None  
 C = Non-Fused Disconnect (NFD)  
 D = Thru-The-Base Connections (TTB)  
 F = Non-Fused Disconnect and TTB Connections  
 N = Phase Monitor Protection  
 Q = Phase Monitor Protection and NFD  
 R = Phase Monitor Protection and TTB Conn.  
 T = Phase Monitor Protection, NFD, and TTB Connections

### Service Options

0 = None  
 1 = Unpowered Convenience Outlet (CO)  
 2 = Powered Convenience Outlet  
 3 = Hinged Access Panels  
 4 = Hinged Access Panels and Unpowered CO  
 5 = Hinged Access Panels and Powered CO  
 6 = MERV-8 High Efficiency (HE) Filters  
 7 = Unpowered CO and MERV-8 HE Filters  
 8 = Powered CO and MERV-8 HE Filters  
 9 = Hinged Access Panels and MERV-8 HE Filters  
 A = Hinged Access Panels, Unpowered CO, and MERV-8 HE Filters  
 B = Hinged Access Panels, Powered CO, and MERV-8 HE Filters

### Intake / Exhaust Options

A = None  
 B = Temperature Economizer w/ Barometric Relief  
 F = Enthalpy Economizer w/ Barometric Relief  
 K = Two-Position Damper  
 U = Temperature Ultra Low Leak Economizer with Barometric Relief  
 W = Enthalpy Ultra Low Leak Economizer with Barometric Relief

### Base Unit Controls

0 = Electromechanical Controls – can be used with field-installed W7212 EconoMiSer® IV (Non-Fault Detection and Diagnostic)<sup>1</sup>  
 2 = RTU Open Multi-Protocol Controller  
 3 = SystemVu™ Controls  
 6 = Electromechanical Controls – can be used with W7220 EconoMiSer X (with Fault Detection and Diagnostic)

### Design Revision

- = Factory Design Revision

<sup>1</sup> Size 04/05/06 models only.

<sup>2</sup> Size 04 and 06 single-phase voltage units meet Department of Energy SEER2 requirements.

<sup>3</sup> Units meet Department of Energy 2023 SEER2 requirements; available on size 05 single-phase voltage models only.

<sup>4</sup> Size 07 units only.

<sup>5</sup> The following are not available as a factory-installed options for models with this voltage code: Coated Coils or Cu Fin Coils, Louvered Hail Guards, Economizer or Two-Position Damper, Powered 115 Volt Convenience Outlet.

**Fig. A — Model Number Nomenclature**

## APPENDIX B – PHYSICAL DATA

### 50FCQ Physical Data

50FCQ UNIT	50FCQA04	50FCQA05	50FCQC05	50FCQA06	50FCQM07
<b>NOMINAL TONS</b>	3	4	4	5	6
<b>BASE UNIT OPERATING WT (lb)<sup>a</sup></b>	467	473	473	584	589
<b>REFRIGERATION SYSTEM</b>					
<b>No. Circuits/No. Compressors/Type</b>	1 / 1 / Scroll	1 / 1 / Scroll	1 / 1 / Scroll	1 / 1 / Scroll	1 / 1 / 2-Stage Scroll
<b>Puron® (R-410A) Charge (lb-oz)</b>	8-0	11-13	11-12.8	14-13	16-0
<b>Metering Device</b>	Acutrol	Acutrol	Acutrol	Acutrol	TXV
<b>High-Pressure Trip/Reset (psig)</b>	630/505	630/505	630/505	630/505	630/505
<b>Low-Pressure Trip/Reset (psig)</b>	54/117	54/117	54/117	54/117	54/117
<b>EVAPORATOR COIL (Indoor)</b>					
<b>Material (Tube/Fin)</b>	Cu/Al	Cu/Al	Cu/Al	Cu/Al	Cu/Al
<b>Coil Type</b>	3/8 in. RTPF	3/8 in. RTPF	3/8 in. RTPF	3/8 in. RTPF	3/8 in. RTPF
<b>Rows/FPI</b>	3/15	3/15	3/15	4/15	4/15
<b>Total Face Area (ft<sup>2</sup>)</b>	5.5	5.5	5.5	7.3	7.3
<b>Condensate Drain Connection Size</b>	3/4 in.	3/4 in.	3/4 in.	3/4 in.	3/4 in.
<b>CONDENSER COIL (Outdoor)</b>					
<b>Material</b>	Cu/Al	Cu/Al	Cu/Al	Cu/Al	Cu/Al
<b>Coil Type</b>	5/16 in. RTPF	5/16 in. RTPF	5/16 in. RTPF	5/16 in. RTPF	5/16 in. RTPF
<b>Rows/FPI</b>	2/18	2/18	2/18	2/18	2/18
<b>Total Face Area (ft<sup>2</sup>)</b>	10.7	15.9	15.9	18.8	20.5
<b>EVAPORATOR FAN AND MOTOR (Indoor)</b>					
<b>Standard Static 1 Phase</b>					
<b>Motor Qty/Drive Type</b>	1/Direct	—	1/Direct	1/Direct	—
<b>Max Cont Bhp</b>	0.44	—	0.72	1.06	—
<b>Rpm Range</b>	189-1890	—	190-1900	215-2150	—
<b>Fan Qty/Type</b>	1/Vane Axial	—	1/Vane Axial	1/Vane Axial	—
<b>Fan Diameter (in.)</b>	16.6	—	16.6	16.6	—
<b>Medium Static 1 Phase</b>					
<b>Motor Qty/Drive Type</b>	1/Direct	—	1/Direct	1/Direct	—
<b>Max Cont Bhp</b>	0.71	—	1.06	1.44	—
<b>Rpm Range</b>	219-2190	—	217-2170	239-2390	—
<b>Fan Qty/Type</b>	1/Vane Axial	—	1/Vane Axial	1/Vane Axial	—
<b>Fan Diameter (in.)</b>	16.6	—	16.6	16.6	—
<b>High Static 1 Phase</b>					
<b>Motor Qty/Drive Type</b>	1/Direct	—	1/Direct	—	—
<b>Max Cont Bhp</b>	1.07	—	1.53	—	—
<b>Rpm Range</b>	249-2490	—	246-2460	—	—
<b>Fan Qty/Type</b>	1/Vane Axial	—	1/Vane Axial	—	—
<b>Fan Diameter (in.)</b>	16.6	—	16.6	—	—
<b>Standard Static 3 Phase</b>					
<b>Motor Qty/Drive Type</b>	1/Direct	1/Direct	—	1/Direct	1/Direct
<b>Max Cont Bhp</b>	0.44	0.72	—	1.06	1.31
<b>Rpm Range</b>	189-1890	190-1900	—	215-2150	230-2300
<b>Fan Qty/Type</b>	1/Vane Axial	1/Vane Axial	—	1/Vane Axial	1/Vane Axial
<b>Fan Diameter (in.)</b>	16.6	16.6	—	16.6	16.6
<b>Medium Static 3 Phase</b>					
<b>Motor Qty/Drive Type</b>	1/Direct	1/Direct	—	1/Direct	1/Direct
<b>Max Cont Bhp</b>	0.71	1.06	—	1.44	1.76
<b>Rpm Range</b>	219-2190	217-2170	—	239-2390	253-2530
<b>Fan Qty/Type</b>	1/Vane Axial	1/Vane Axial	—	1/Vane Axial	1/Vane Axial
<b>Fan Diameter (in.)</b>	16.6	16.6	—	16.6	16.6
<b>High Static 3 Phase</b>					
<b>Motor Qty/Drive Type</b>	1/Direct	1/Direct	—	1/Direct	1/Direct
<b>Max Cont Bhp</b>	1.07	1.96	—	2.43	2.43
<b>Rpm Range</b>	249-2490	266-2660	—	284-2836	284-2836
<b>Fan Qty/Type</b>	1/Vane Axial	1/Vane Axial	—	1/Vane Axial	1/Vane Axial
<b>Fan Diameter (in.)</b>	16.6	16.6	—	16.6	16.6

**APPENDIX B — PHYSICAL DATA (cont)**

**50FCQ Physical Data (cont)**

<b>50FCQ UNIT</b>	<b>50FCQA04</b>	<b>50FCQA05</b>	<b>50FCQC05</b>	<b>50FCQA06</b>	<b>50FCQM07</b>
<b>CONDENSER FAN AND MOTOR (Outdoor)</b>					
Qty / Motor Drive Type	1 / Direct	1 / Direct	1 / Direct	1 / Direct	1 / Direct
Motor Hp/Rpm	1/4 / 1100	1/4 / 1100	1/4 / 1100	1/4 / 1100	1/4 / 1100
Fan Diameter (in.)	23	23	23	23	23
<b>FILTERS</b>					
RA Filter Qty / Size (in.)	2 / 16x25x2	2 / 16x25x2	2 / 16x25x2	4 / 16x16x2	4 / 16x16x2
OA Inlet Screen Qty / Size (in.)	1 / 20x24x1	1 / 20x24x1	1 / 20x24x1	1 / 20x24x1	1 / 20x24x1

NOTE(S):

- a. Base unit operating weight does not include weight of options.



## APPENDIX C — FAN PERFORMANCE

### GENERAL FAN PERFORMANCE NOTES

1. Interpolation is permissible. Do not extrapolate.
2. External static pressure is the static pressure difference between the return duct and the supply duct plus the static pressure caused by any FIOPs or accessories.
3. Tabular data accounts for pressure loss due to clean filters, unit casing, and wet coils.
4. Factory options and accessories may effect static pressure losses. Selection software is available, through your salesperson, to help you select the best motor/drive combination for your application.
5. The fan performance tables offer motor/drive recommendations. In cases when 2 motor/drive combinations would work, Carrier recommends the lower horsepower option.
6. For information on the electrical properties of Carrier motors, please see the Electrical Data section of the product data book for this model and size.
7. For more information on the performance limits of Carrier motors, see the application data section of the product data book for this model and size.
8. The EPACT (Energy Policy Act of 1992) regulates energy requirements for specific types of indoor fan motors. Motors regulated by EPACT include any general purpose, T-frame (3-digit, 143 and larger), single-speed, foot mounted, polyphase, squirrel cage induction motors of NEMA (National Electrical Manufacturers Association) design A and B, manufactured for use in the United States. Ranging from 1 to 200 hp, these continuous-duty motors operate on 230 and 460 volt, 60 Hz power. If a motor does not fit into these specifications, the motor does not have to be replaced by an EPACT compliant energy-efficient motor. Variable-speed motors are exempt from EPACT compliance requirements.





**APPENDIX C – FAN PERFORMANCE (cont)**

**50FCQA04 Single Phase – 3 Ton Vertical Supply (rpm - bhp)**

CFM	AVAILABLE EXTERNAL STATIC PRESSURE (in. wg)									
	0.2		0.4		0.6		0.8		1.0	
	rpm	bhp	rpm	bhp	rpm	bhp	rpm	bhp	rpm	bhp
900	1060	0.08	1325	0.16	1541	0.25	1718	0.35	1871	0.46
975	1103	0.09	1355	0.17	1572	0.27	1752	0.37	1906	0.48
1050	1150	0.11	1387	0.19	1602	0.29	1784	0.40	1941	0.51
1125	1198	0.12	1422	0.20	1632	0.30	1815	0.42	1974	0.54
1200	1249	0.14	1459	0.22	1662	0.32	1845	0.44	2005	0.56
1275	1303	0.15	1499	0.23	1694	0.34	1874	0.46	2036	0.59
1350	1357	0.17	1542	0.26	1728	0.36	1905	0.48	2066	0.61
1425	1413	0.20	1587	0.28	1765	0.38	1936	0.51	2095	0.64
1500	1469	0.22	1635	0.30	1803	0.41	1969	0.53	2126	0.67

CFM	AVAILABLE EXTERNAL STATIC PRESSURE (in. wg)									
	1.2		1.4		1.6		1.8		2.0	
	rpm	bhp	rpm	bhp	rpm	bhp	rpm	bhp	rpm	bhp
900	2006	0.56	2130	0.67	2244	0.79	2352	0.91	2453	1.03
975	2044	0.59	2168	0.71	2283	0.83	2391	0.95	—	—
1050	2080	0.63	2206	0.75	2322	0.87	2430	1.00	—	—
1125	2115	0.66	2242	0.78	2359	0.91	2468	1.05	—	—
1200	2148	0.69	2277	0.82	2396	0.96	—	—	—	—
1275	2180	0.72	2311	0.86	2431	1.00	—	—	—	—
1350	2211	0.75	2343	0.90	2465	1.04	—	—	—	—
1425	2241	0.78	2375	0.93	—	—	—	—	—	—
1500	2271	0.82	2405	0.97	—	—	—	—	—	—

Standard Static 1060-1890 rpm, 0.44 max bhp

Medium Static 1060-2190 rpm, 0.71 max bhp

High Static 1060-2490 rpm, 1.07 max bhp

**50FCQA04 Single Phase – Standard Static – 3 Ton Vertical Supply (rpm - vdc)**

CFM	AVAILABLE EXTERNAL STATIC PRESSURE (in. wg)									
	0.2		0.4		0.6		0.8		1.0	
	rpm	vdc	rpm	vdc	rpm	vdc	rpm	vdc	rpm	vdc
900	1060	5.6	1325	7.0	1541	8.2	1718	9.1	1871	9.9
975	1103	5.8	1355	7.2	1572	8.3	1752	9.3	—	—
1050	1150	6.1	1387	7.3	1602	8.5	1784	9.4	—	—
1125	1198	6.3	1422	7.5	1632	8.6	1815	9.6	—	—
1200	1249	6.6	1459	7.7	1662	8.8	1845	9.8	—	—
1275	1303	6.9	1499	7.9	1694	9.0	1874	9.9	—	—
1350	1357	7.2	1542	8.2	1728	9.1	—	—	—	—
1425	1413	7.5	1587	8.4	1765	9.3	—	—	—	—
1500	1469	7.8	1635	8.7	1803	9.5	—	—	—	—

CFM	AVAILABLE EXTERNAL STATIC PRESSURE (in. wg)									
	1.2		1.4		1.6		1.8		2.0	
	rpm	vdc	rpm	vdc	rpm	vdc	rpm	vdc	rpm	vdc
900	—	—	—	—	—	—	—	—	—	—
975	—	—	—	—	—	—	—	—	—	—
1050	—	—	—	—	—	—	—	—	—	—
1125	—	—	—	—	—	—	—	—	—	—
1200	—	—	—	—	—	—	—	—	—	—
1275	—	—	—	—	—	—	—	—	—	—
1350	—	—	—	—	—	—	—	—	—	—
1425	—	—	—	—	—	—	—	—	—	—
1500	—	—	—	—	—	—	—	—	—	—

Standard Static 1060-1890 rpm

## APPENDIX C – FAN PERFORMANCE (cont)

### 50FCQA04 Single Phase – Medium Static – 3 Ton Vertical Supply (rpm - vdc)

CFM	AVAILABLE EXTERNAL STATIC PRESSURE (in. wg)									
	0.2		0.4		0.6		0.8		1.0	
	rpm	vdc	rpm	vdc	rpm	vdc	rpm	vdc	rpm	vdc
900	1060	4.8	1325	6.1	1541	7.0	1718	7.8	1871	8.5
975	1103	5.0	1355	6.2	1572	7.2	1752	8.0	1906	8.7
1050	1150	5.3	1387	6.3	1602	7.3	1784	8.1	1941	8.9
1125	1198	5.5	1422	6.5	1632	7.5	1815	8.3	1974	9.0
1200	1249	5.7	1459	6.7	1662	7.6	1845	8.4	2005	9.2
1275	1303	5.9	1499	6.8	1694	7.7	1874	8.6	2036	9.3
1350	1357	6.2	1542	7.0	1728	7.9	1905	8.7	2066	9.4
1425	1413	6.5	1587	7.2	1765	8.1	1936	8.8	2095	9.6
1500	1469	6.7	1635	7.5	1803	8.2	1969	9.0	2126	9.7

CFM	AVAILABLE EXTERNAL STATIC PRESSURE (in. wg)									
	1.2		1.4		1.6		1.8		2.0	
	rpm	vdc	rpm	vdc	rpm	vdc	rpm	vdc	rpm	vdc
900	2006	9.2	2130	9.7	—	—	—	—	—	—
975	2044	9.3	2168	9.9	—	—	—	—	—	—
1050	2080	9.5	—	—	—	—	—	—	—	—
1125	2115	9.7	—	—	—	—	—	—	—	—
1200	2148	9.8	—	—	—	—	—	—	—	—
1275	2180	10.0	—	—	—	—	—	—	—	—
1350	—	—	—	—	—	—	—	—	—	—
1425	—	—	—	—	—	—	—	—	—	—
1500	—	—	—	—	—	—	—	—	—	—

Medium Static 1060-2190 rpm

### 50FCQA04 Single Phase – High Static – 3 Ton Vertical Supply (rpm - vdc)

CFM	AVAILABLE EXTERNAL STATIC PRESSURE (in. wg)									
	0.2		0.4		0.6		0.8		1.0	
	rpm	vdc	rpm	vdc	rpm	vdc	rpm	vdc	rpm	vdc
900	1060	4.3	1325	5.3	1541	6.2	1718	6.9	1871	7.5
975	1103	4.4	1355	5.4	1572	6.3	1752	7.0	1906	7.7
1050	1150	4.6	1387	5.6	1602	6.4	1784	7.2	1941	7.8
1125	1198	4.8	1422	5.7	1632	6.6	1815	7.3	1974	7.9
1200	1249	5.0	1459	5.9	1662	6.7	1845	7.4	2005	8.1
1275	1303	5.2	1499	6.0	1694	6.8	1874	7.5	2036	8.2
1350	1357	5.4	1542	6.2	1728	6.9	1905	7.7	2066	8.3
1425	1413	5.7	1587	6.4	1765	7.1	1936	7.8	2095	8.4
1500	1469	5.9	1635	6.6	1803	7.2	1969	7.9	2126	8.5

CFM	AVAILABLE EXTERNAL STATIC PRESSURE (in. wg)									
	1.2		1.4		1.6		1.8		2.0	
	rpm	vdc	rpm	vdc	rpm	vdc	rpm	vdc	rpm	vdc
900	2006	8.1	2130	8.6	2244	9.0	2352	9.4	2453	9.9
975	2044	8.2	2168	8.7	2283	9.2	2391	9.6	—	—
1050	2080	8.4	2206	8.9	2322	9.3	2430	9.8	—	—
1125	2115	8.5	2242	9.0	2359	9.5	2468	9.9	—	—
1200	2148	8.6	2277	9.1	2396	9.6	—	—	—	—
1275	2180	8.8	2311	9.3	2431	9.8	—	—	—	—
1350	2211	8.9	2343	9.4	2465	9.9	—	—	—	—
1425	2241	9.0	2375	9.5	—	—	—	—	—	—
1500	2271	9.1	2405	9.7	—	—	—	—	—	—

High Static 1060-2490 rpm

**APPENDIX C – FAN PERFORMANCE (cont)**

**50FCQA04 Three Phase – 3 Ton Vertical Supply (rpm - bhp)**

CFM	AVAILABLE EXTERNAL STATIC PRESSURE (in. wg)									
	0.2		0.4		0.6		0.8		1.0	
	rpm	bhp	rpm	bhp	rpm	bhp	rpm	bhp	rpm	bhp
900	1060	0.08	1325	0.16	1541	0.25	1718	0.35	1871	0.46
975	1103	0.09	1355	0.17	1572	0.27	1752	0.37	1906	0.48
1050	1150	0.11	1387	0.19	1602	0.29	1784	0.40	1941	0.51
1125	1198	0.12	1422	0.20	1632	0.30	1815	0.42	1974	0.54
1200	1249	0.14	1460	0.22	1662	0.32	1845	0.44	2005	0.56
1275	1303	0.15	1499	0.23	1694	0.34	1874	0.46	2036	0.59
1350	1357	0.17	1542	0.26	1728	0.36	1905	0.48	2066	0.61
1425	1413	0.20	1587	0.28	1765	0.38	1936	0.51	2095	0.64
1500	1469	0.22	1635	0.30	1803	0.41	1969	0.53	2126	0.67

CFM	AVAILABLE EXTERNAL STATIC PRESSURE (in. wg)									
	1.2		1.4		1.6		1.8		2.0	
	rpm	bhp	rpm	bhp	rpm	bhp	rpm	bhp	rpm	bhp
900	2006	0.56	2130	0.67	2245	0.79	2352	0.91	2454	1.03
975	2044	0.59	2169	0.71	2284	0.83	2391	0.95	—	—
1050	2080	0.63	2206	0.75	2322	0.87	2430	1.00	—	—
1125	2115	0.66	2242	0.78	2360	0.92	2469	1.05	—	—
1200	2148	0.69	2277	0.82	2396	0.96	—	—	—	—
1275	2180	0.72	2311	0.86	2431	1.00	—	—	—	—
1350	2211	0.75	2343	0.90	2465	1.04	—	—	—	—
1425	2241	0.78	2375	0.93	—	—	—	—	—	—
1500	2271	0.82	2405	0.97	—	—	—	—	—	—

Standard Static 1060-1890 rpm, 0.44 max bhp

Medium Static 1060-2190 rpm, 0.71 max bhp

High Static 1060-2490 rpm, 1.07 max bhp

**50FCQA04 Three Phase – Standard Static – 3 Ton Vertical Supply (rpm - vdc)**

CFM	AVAILABLE EXTERNAL STATIC PRESSURE (in. wg)									
	0.2		0.4		0.6		0.8		1.0	
	rpm	vdc	rpm	vdc	rpm	vdc	rpm	vdc	rpm	vdc
900	1060	5.6	1325	7.0	1541	8.2	1718	9.1	1871	9.9
975	1103	5.8	1355	7.2	1572	8.3	1752	9.3	—	—
1050	1150	6.1	1387	7.3	1602	8.5	1784	9.4	—	—
1125	1198	6.3	1422	7.5	1632	8.6	1815	9.6	—	—
1200	1249	6.6	1460	7.7	1662	8.8	1845	9.8	—	—
1275	1303	6.9	1499	7.9	1694	9.0	1874	9.9	—	—
1350	1357	7.2	1542	8.2	1728	9.1	—	—	—	—
1425	1413	7.5	1587	8.4	1765	9.3	—	—	—	—
1500	1469	7.8	1635	8.7	1803	9.5	—	—	—	—

CFM	AVAILABLE EXTERNAL STATIC PRESSURE (in. wg)									
	1.2		1.4		1.6		1.8		2.0	
	rpm	vdc	rpm	vdc	rpm	vdc	rpm	vdc	rpm	vdc
900	—	—	—	—	—	—	—	—	—	—
975	—	—	—	—	—	—	—	—	—	—
1050	—	—	—	—	—	—	—	—	—	—
1125	—	—	—	—	—	—	—	—	—	—
1200	—	—	—	—	—	—	—	—	—	—
1275	—	—	—	—	—	—	—	—	—	—
1350	—	—	—	—	—	—	—	—	—	—
1425	—	—	—	—	—	—	—	—	—	—
1500	—	—	—	—	—	—	—	—	—	—

Standard Static 1060-1890 rpm

## APPENDIX C – FAN PERFORMANCE (cont)

### 50FCQA04 Three Phase – Medium Static – 3 Ton Vertical Supply (rpm - vdc)

CFM	AVAILABLE EXTERNAL STATIC PRESSURE (in. wg)									
	0.2		0.4		0.6		0.8		1.0	
	rpm	vdc	rpm	vdc	rpm	vdc	rpm	vdc	rpm	vdc
900	1060	4.8	1325	6.1	1541	7.0	1718	7.8	1871	8.5
975	1103	5.0	1355	6.2	1572	7.2	1752	8.0	1906	8.7
1050	1150	5.3	1387	6.3	1602	7.3	1784	8.1	1941	8.9
1125	1198	5.5	1422	6.5	1632	7.5	1815	8.3	1974	9.0
1200	1249	5.7	1460	6.7	1662	7.6	1845	8.4	2005	9.2
1275	1303	5.9	1499	6.8	1694	7.7	1874	8.6	2036	9.3
1350	1357	6.2	1542	7.0	1728	7.9	1905	8.7	2066	9.4
1425	1413	6.5	1587	7.2	1765	8.1	1936	8.8	2095	9.6
1500	1469	6.7	1635	7.5	1803	8.2	1969	9.0	2126	9.7

CFM	AVAILABLE EXTERNAL STATIC PRESSURE (in. wg)									
	1.2		1.4		1.6		1.8		2.0	
	rpm	vdc	rpm	vdc	rpm	vdc	rpm	vdc	rpm	vdc
900	2006	9.2	2130	9.7	—	—	—	—	—	—
975	2044	9.3	2169	9.9	—	—	—	—	—	—
1050	2080	9.5	—	—	—	—	—	—	—	—
1125	2115	9.7	—	—	—	—	—	—	—	—
1200	2148	9.8	—	—	—	—	—	—	—	—
1275	2180	10.0	—	—	—	—	—	—	—	—
1350	—	—	—	—	—	—	—	—	—	—
1425	—	—	—	—	—	—	—	—	—	—
1500	—	—	—	—	—	—	—	—	—	—

Medium Static 1060-2190 rpm

### 50FCQA04 Three Phase – High Static – 3 Ton Vertical Supply (rpm - vdc)

CFM	AVAILABLE EXTERNAL STATIC PRESSURE (in. wg)									
	0.2		0.4		0.6		0.8		1.0	
	rpm	vdc	rpm	vdc	rpm	vdc	rpm	vdc	rpm	vdc
900	1060	4.3	1325	5.3	1541	6.2	1718	6.9	1871	7.5
975	1103	4.4	1355	5.4	1572	6.3	1752	7.0	1906	7.7
1050	1150	4.6	1387	5.6	1602	6.4	1784	7.2	1941	7.8
1125	1198	4.8	1422	5.7	1632	6.6	1815	7.3	1974	7.9
1200	1249	5.0	1460	5.9	1662	6.7	1845	7.4	2005	8.1
1275	1303	5.2	1499	6.0	1694	6.8	1874	7.5	2036	8.2
1350	1357	5.4	1542	6.2	1728	6.9	1905	7.7	2066	8.3
1425	1413	5.7	1587	6.4	1765	7.1	1936	7.8	2095	8.4
1500	1469	5.9	1635	6.6	1803	7.2	1969	7.9	2126	8.5

CFM	AVAILABLE EXTERNAL STATIC PRESSURE (in. wg)									
	1.2		1.4		1.6		1.8		2.0	
	rpm	vdc	rpm	vdc	rpm	vdc	rpm	vdc	rpm	vdc
900	2006	8.1	2130	8.6	2245	9.0	2352	9.4	2454	9.9
975	2044	8.2	2169	8.7	2284	9.2	2391	9.6	—	—
1050	2080	8.4	2206	8.9	2322	9.3	2430	9.8	—	—
1125	2115	8.5	2242	9.0	2360	9.5	2469	9.9	—	—
1200	2148	8.6	2277	9.1	2396	9.6	—	—	—	—
1275	2180	8.8	2311	9.3	2431	9.8	—	—	—	—
1350	2211	8.9	2343	9.4	2465	9.9	—	—	—	—
1425	2241	9.0	2375	9.5	—	—	—	—	—	—
1500	2271	9.1	2405	9.7	—	—	—	—	—	—

High Static 1060-2490 rpm



**APPENDIX C – FAN PERFORMANCE (cont)**

**50FCQC05 Single Phase – 4 Ton Vertical Supply (rpm - bhp)**

CFM	AVAILABLE EXTERNAL STATIC PRESSURE (in. wg)									
	0.2		0.4		0.6		0.8		1.0	
	rpm	bhp	rpm	bhp	rpm	bhp	rpm	bhp	rpm	bhp
1200	1095	0.14	1302	0.24	1484	0.35	1646	0.48	1794	0.63
1300	1151	0.16	1347	0.26	1523	0.38	1681	0.51	1826	0.66
1400	1209	0.19	1395	0.29	1565	0.41	1719	0.55	1860	0.69
1500	1269	0.22	1444	0.32	1608	0.45	1758	0.58	1897	0.73
1600	1331	0.25	1496	0.36	1654	0.48	1800	0.62	1935	0.78
1700	1396	0.29	1550	0.40	1701	0.53	1843	0.67	1975	0.82
1800	1462	0.33	1605	0.44	1750	0.57	1888	0.72	2017	0.87
1900	1528	0.38	1663	0.49	1801	0.62	1934	0.77	2060	0.93
2000	1596	0.43	1722	0.54	1854	0.68	1982	0.83	2105	0.99

CFM	AVAILABLE EXTERNAL STATIC PRESSURE (in. wg)									
	1.2		1.4		1.6		1.8		2.0	
	rpm	bhp	rpm	bhp	rpm	bhp	rpm	bhp	rpm	bhp
1200	1931	0.78	2058	0.95	2177	1.12	2288	1.30	2394	1.49
1300	1961	0.82	2086	0.98	2205	1.16	2316	1.34	2422	1.54
1400	1993	0.85	2116	1.02	2233	1.20	2344	1.39	2450	1.58
1500	2026	0.89	2148	1.06	2264	1.25	2373	1.44	—	—
1600	2062	0.94	2181	1.11	2296	1.30	2404	1.49	—	—
1700	2099	0.99	2217	1.16	2328	1.35	2435	1.54	—	—
1800	2138	1.04	2254	1.22	2363	1.41	—	—	—	—
1900	2179	1.10	2292	1.28	2400	1.47	—	—	—	—
2000	2221	1.16	2332	1.34	2438	1.54	—	—	—	—

Standard Static 1095-1900 rpm, 0.72 max bhp

Medium Static 1095-2170 rpm, 1.06 max bhp

High Static 1095-2460 rpm, 1.53 max bhp

**50FCQC05 Single Phase – Standard Static – 4 Ton Vertical Supply (rpm - vdc)**

CFM	AVAILABLE EXTERNAL STATIC PRESSURE (in. wg)									
	0.2		0.4		0.6		0.8		1.0	
	rpm	vdc	rpm	vdc	rpm	vdc	rpm	vdc	rpm	vdc
1200	1094	5.8	1302	6.9	1484	7.8	1646	8.7	1794	9.4
1300	1150	6.1	1347	7.1	1523	8.0	1681	8.8	1826	9.6
1400	1209	6.4	1395	7.3	1565	8.2	1719	9.0	1860	9.8
1500	1269	6.7	1444	7.6	1608	8.5	1758	9.3	1897	10.0
1600	1332	7.0	1496	7.9	1654	8.7	1800	9.5	—	—
1700	1396	7.3	1549	8.2	1701	9.0	1843	9.7	—	—
1800	1461	7.7	1605	8.4	1750	9.2	1888	9.9	—	—
1900	1528	8.0	1662	8.7	1801	9.5	—	—	—	—
2000	1596	8.4	1721	9.1	1853	9.8	—	—	—	—

CFM	AVAILABLE EXTERNAL STATIC PRESSURE (in. wg)									
	1.2		1.4		1.6		1.8		2.0	
	rpm	vdc	rpm	vdc	rpm	vdc	rpm	vdc	rpm	vdc
1200	—	—	—	—	—	—	—	—	—	—
1300	—	—	—	—	—	—	—	—	—	—
1400	—	—	—	—	—	—	—	—	—	—
1500	—	—	—	—	—	—	—	—	—	—
1600	—	—	—	—	—	—	—	—	—	—
1700	—	—	—	—	—	—	—	—	—	—
1800	—	—	—	—	—	—	—	—	—	—
1900	—	—	—	—	—	—	—	—	—	—
2000	—	—	—	—	—	—	—	—	—	—

Standard Static 1094-1900 rpm

## APPENDIX C – FAN PERFORMANCE (cont)

### 50FCQC05 Single Phase – Medium Static – 4 Ton Vertical Supply (rpm - vdc)

CFM	AVAILABLE EXTERNAL STATIC PRESSURE (in. wg)									
	0.2		0.4		0.6		0.8		1.0	
	rpm	vdc	rpm	vdc	rpm	vdc	rpm	vdc	rpm	vdc
1200	1094	5.0	1302	6.0	1484	6.8	1646	7.6	1794	8.3
1300	1150	5.3	1347	6.2	1523	7.0	1681	7.7	1826	8.4
1400	1209	5.6	1395	6.4	1565	7.2	1719	7.9	1860	8.6
1500	1269	5.8	1444	6.7	1608	7.4	1758	8.1	1897	8.7
1600	1332	6.1	1496	6.9	1654	7.6	1800	8.3	1935	8.9
1700	1396	6.4	1549	7.1	1701	7.8	1843	8.5	1975	9.1
1800	1461	6.7	1605	7.4	1750	8.1	1888	8.7	2017	9.3
1900	1528	7.0	1662	7.7	1801	8.3	1934	8.9	2060	9.5
2000	1596	7.4	1721	7.9	1853	8.5	1982	9.1	2105	9.7

CFM	AVAILABLE EXTERNAL STATIC PRESSURE (in. wg)									
	1.2		1.4		1.6		1.8		2.0	
	rpm	vdc	rpm	vdc	rpm	vdc	rpm	vdc	rpm	vdc
1200	1930	8.9	2058	9.5	—	—	—	—	—	—
1300	1960	9.0	2086	9.6	—	—	—	—	—	—
1400	1992	9.2	2116	9.8	—	—	—	—	—	—
1500	2026	9.3	2148	9.9	—	—	—	—	—	—
1600	2062	9.5	—	—	—	—	—	—	—	—
1700	2099	9.7	—	—	—	—	—	—	—	—
1800	2138	9.9	—	—	—	—	—	—	—	—
1900	—	—	—	—	—	—	—	—	—	—
2000	—	—	—	—	—	—	—	—	—	—

Medium Static 1094-2170 rpm

### 50FCQC05 Single Phase – High Static – 4 Ton Vertical Supply (rpm - vdc)

CFM	AVAILABLE EXTERNAL STATIC PRESSURE (in. wg)									
	0.2		0.4		0.6		0.8		1.0	
	rpm	vdc	rpm	vdc	rpm	vdc	rpm	vdc	rpm	vdc
1200	1094	4.4	1302	5.3	1484	6.0	1646	6.7	1794	7.3
1300	1150	4.7	1347	5.5	1523	6.2	1681	6.8	1826	7.4
1400	1209	4.9	1395	5.7	1565	6.4	1719	7.0	1860	7.6
1500	1269	5.2	1444	5.9	1608	6.5	1758	7.1	1897	7.7
1600	1332	5.4	1496	6.1	1654	6.7	1800	7.3	1935	7.9
1700	1396	5.7	1549	6.3	1701	6.9	1843	7.5	1975	8.0
1800	1461	5.9	1605	6.5	1750	7.1	1888	7.7	2017	8.2
1900	1528	6.2	1662	6.8	1801	7.3	1934	7.9	2060	8.4
2000	1596	6.5	1721	7.0	1853	7.5	1982	8.1	2105	8.6

CFM	AVAILABLE EXTERNAL STATIC PRESSURE (in. wg)									
	1.2		1.4		1.6		1.8		2.0	
	rpm	vdc	rpm	vdc	rpm	vdc	rpm	vdc	rpm	vdc
1200	1930	7.8	2058	8.4	2177	8.8	2288	9.3	2394	9.7
1300	1960	8.0	2086	8.5	2205	9.0	2316	9.4	2422	9.8
1400	1992	8.1	2116	8.6	2233	9.1	2344	9.5	2450	10.0
1500	2026	8.2	2148	8.7	2263	9.2	2373	9.6	—	—
1600	2062	8.4	2181	8.9	2295	9.3	2403	9.8	—	—
1700	2099	8.5	2217	9.0	2328	9.5	2435	9.9	—	—
1800	2138	8.7	2254	9.2	2363	9.6	—	—	—	—
1900	2179	8.9	2292	9.3	2400	9.8	—	—	—	—
2000	2221	9.0	2332	9.5	2438	9.9	—	—	—	—

High Static 1094-2460 rpm

**APPENDIX C – FAN PERFORMANCE (cont)**

**50FCQA05 Three Phase – 4 Ton Vertical Supply (rpm - bhp)**

CFM	AVAILABLE EXTERNAL STATIC PRESSURE (in. wg)									
	0.2		0.4		0.6		0.8		1.0	
	rpm	bhp	rpm	bhp	rpm	bhp	rpm	bhp	rpm	bhp
1200	1094	0.14	1302	0.24	1484	0.35	1646	0.48	1794	0.63
1300	1150	0.16	1347	0.26	1524	0.38	1681	0.51	1826	0.66
1400	1209	0.19	1395	0.29	1565	0.41	1719	0.55	1860	0.69
1500	1269	0.22	1444	0.32	1608	0.45	1759	0.58	1897	0.73
1600	1332	0.25	1496	0.36	1654	0.48	1800	0.62	1935	0.78
1700	1396	0.29	1549	0.40	1701	0.53	1843	0.67	1976	0.82
1800	1461	0.33	1605	0.44	1750	0.57	1888	0.72	2017	0.87
1900	1528	0.38	1662	0.49	1801	0.62	1934	0.77	2060	0.93
2000	1596	0.43	1721	0.54	1853	0.67	1982	0.83	2105	0.99

CFM	AVAILABLE EXTERNAL STATIC PRESSURE (in. wg)									
	1.2		1.4		1.6		1.8		2.0	
	rpm	bhp	rpm	bhp	rpm	bhp	rpm	bhp	rpm	bhp
1200	1930	0.78	2058	0.95	2177	1.12	2288	1.30	2394	1.49
1300	1960	0.81	2086	0.98	2205	1.16	2316	1.34	2422	1.54
1400	1992	0.85	2116	1.02	2233	1.20	2344	1.39	2450	1.58
1500	2026	0.89	2148	1.06	2263	1.24	2373	1.44	2478	1.63
1600	2062	0.94	2181	1.11	2295	1.29	2403	1.49	2507	1.69
1700	2099	0.99	2217	1.16	2328	1.35	2435	1.54	2538	1.75
1800	2138	1.04	2254	1.22	2363	1.40	2469	1.60	2570	1.81
1900	2180	1.10	2292	1.28	2400	1.47	2503	1.67	2603	1.87
2000	2222	1.16	2332	1.34	2438	1.54	2540	1.74	2638	1.95

- Standard Static 1094-1900 rpm, 0.72 max bhp
- Medium Static 1094-2170 rpm, 1.06 max bhp
- High Static 1094-2660 rpm, 1.96 max bhp

**50FCQA05 Three Phase – Standard Static – 4 Ton Vertical Supply (rpm - vdc)**

CFM	AVAILABLE EXTERNAL STATIC PRESSURE (in. wg)									
	0.2		0.4		0.6		0.8		1.0	
	rpm	vdc	rpm	vdc	rpm	vdc	rpm	vdc	rpm	vdc
1200	1094	5.8	1302	6.9	1484	7.8	1646	8.7	1794	9.4
1300	1150	6.1	1347	7.1	1524	8.0	1681	8.8	1826	9.6
1400	1209	6.4	1395	7.3	1565	8.2	1719	9.0	1860	9.8
1500	1269	6.7	1444	7.6	1608	8.5	1759	9.3	1897	10.0
1600	1332	7.0	1496	7.9	1654	8.7	1800	9.5	—	—
1700	1396	7.3	1549	8.2	1701	9.0	1843	9.7	—	—
1800	1461	7.7	1605	8.4	1750	9.2	1888	9.9	—	—
1900	1528	8.0	1662	8.7	1801	9.5	—	—	—	—
2000	1596	8.4	1721	9.1	1853	9.8	—	—	—	—

CFM	AVAILABLE EXTERNAL STATIC PRESSURE (in. wg)									
	1.2		1.4		1.6		1.8		2.0	
	rpm	vdc	rpm	vdc	rpm	vdc	rpm	vdc	rpm	vdc
1200	—	—	—	—	—	—	—	—	—	—
1300	—	—	—	—	—	—	—	—	—	—
1400	—	—	—	—	—	—	—	—	—	—
1500	—	—	—	—	—	—	—	—	—	—
1600	—	—	—	—	—	—	—	—	—	—
1700	—	—	—	—	—	—	—	—	—	—
1800	—	—	—	—	—	—	—	—	—	—
1900	—	—	—	—	—	—	—	—	—	—
2000	—	—	—	—	—	—	—	—	—	—

- Standard Static 1094-1900 rpm

## APPENDIX C – FAN PERFORMANCE (cont)

### 50FCQA05 Three Phase – Medium Static – 4 Ton Vertical Supply (rpm - vdc)

CFM	AVAILABLE EXTERNAL STATIC PRESSURE (in. wg)									
	0.2		0.4		0.6		0.8		1.0	
	rpm	vdc	rpm	vdc	rpm	vdc	rpm	vdc	rpm	vdc
1200	1094	5.0	1302	6.0	1484	6.8	1646	7.6	1794	8.3
1300	1150	5.3	1347	6.2	1524	7.0	1681	7.7	1826	8.4
1400	1209	5.6	1395	6.4	1565	7.2	1719	7.9	1860	8.6
1500	1269	5.8	1444	6.7	1608	7.4	1759	8.1	1897	8.7
1600	1332	6.1	1496	6.9	1654	7.6	1800	8.3	1935	8.9
1700	1396	6.4	1549	7.1	1701	7.8	1843	8.5	1976	9.1
1800	1461	6.7	1605	7.4	1750	8.1	1888	8.7	2017	9.3
1900	1528	7.0	1662	7.7	1801	8.3	1934	8.9	2060	9.5
2000	1596	7.4	1721	7.9	1853	8.5	1982	9.1	2105	9.7

CFM	AVAILABLE EXTERNAL STATIC PRESSURE (in. wg)									
	1.2		1.4		1.6		1.8		2.0	
	rpm	vdc	rpm	vdc	rpm	vdc	rpm	vdc	rpm	vdc
1200	1930	8.9	2058	9.5	—	—	—	—	—	—
1300	1960	9.0	2086	9.6	—	—	—	—	—	—
1400	1992	9.2	2116	9.8	—	—	—	—	—	—
1500	2026	9.3	2148	9.9	—	—	—	—	—	—
1600	2062	9.5	—	—	—	—	—	—	—	—
1700	2099	9.7	—	—	—	—	—	—	—	—
1800	2138	9.9	—	—	—	—	—	—	—	—
1900	—	—	—	—	—	—	—	—	—	—
2000	—	—	—	—	—	—	—	—	—	—

Medium Static 1094-2170 rpm

### 50FCQA05 Three Phase – High Static – 4 Ton Vertical Supply (rpm - vdc)

CFM	AVAILABLE EXTERNAL STATIC PRESSURE (in. wg)									
	0.2		0.4		0.6		0.8		1.0	
	rpm	vdc	rpm	vdc	rpm	vdc	rpm	vdc	rpm	vdc
1200	1094	4.1	1302	4.9	1484	5.6	1646	6.2	1794	6.7
1300	1150	4.3	1347	5.1	1524	5.7	1681	6.3	1826	6.9
1400	1209	4.5	1395	5.2	1565	5.9	1719	6.5	1860	7.0
1500	1269	4.8	1444	5.4	1608	6.0	1759	6.6	1897	7.1
1600	1332	5.0	1496	5.6	1654	6.2	1800	6.8	1935	7.3
1700	1396	5.2	1549	5.8	1701	6.4	1843	6.9	1976	7.4
1800	1461	5.5	1605	6.0	1750	6.6	1888	7.1	2017	7.6
1900	1528	5.7	1662	6.2	1801	6.8	1934	7.3	2060	7.7
2000	1596	6.0	1721	6.5	1853	7.0	1982	7.5	2105	7.9

CFM	AVAILABLE EXTERNAL STATIC PRESSURE (in. wg)									
	1.2		1.4		1.6		1.8		2.0	
	rpm	vdc	rpm	vdc	rpm	vdc	rpm	vdc	rpm	vdc
1200	1930	7.3	2058	7.7	2177	8.2	2288	8.6	2394	9.0
1300	1960	7.4	2086	7.8	2205	8.3	2316	8.7	2422	9.1
1400	1992	7.5	2116	8.0	2233	8.4	2344	8.8	2450	9.2
1500	2026	7.6	2148	8.1	2263	8.5	2373	8.9	2478	9.3
1600	2062	7.8	2181	8.2	2295	8.6	2403	9.0	2507	9.4
1700	2099	7.9	2217	8.3	2328	8.8	2435	9.2	2538	9.5
1800	2138	8.0	2254	8.5	2363	8.9	2469	9.3	2570	9.7
1900	2180	8.2	2292	8.6	2400	9.0	2503	9.4	2603	9.8
2000	2222	8.4	2332	8.8	2438	9.2	2540	9.5	2638	9.9

High Static 1094-2660 rpm



## APPENDIX C — FAN PERFORMANCE (cont)

### 50FCQA06 Single Phase — 5 Ton Vertical Supply (rpm - bhp)

CFM	AVAILABLE EXTERNAL STATIC PRESSURE (in. wg)									
	0.2		0.4		0.6		0.8		1.0	
	rpm	bhp	rpm	bhp	rpm	bhp	rpm	bhp	rpm	bhp
1500	1228	0.20	1394	0.29	1554	0.40	1701	0.53	1836	0.66
1625	1305	0.24	1457	0.33	1609	0.44	1750	0.57	1882	0.71
1750	1384	0.28	1523	0.37	1666	0.49	1802	0.62	1930	0.76
1875	1466	0.33	1592	0.43	1726	0.54	1857	0.67	1981	0.82
2000	1549	0.39	1664	0.48	1789	0.60	1914	0.74	2034	0.88
2125	1633	0.46	1739	0.55	1855	0.67	1974	0.81	2089	0.95
2250	1718	0.53	1816	0.63	1924	0.74	2036	0.88	2146	1.03
2375	1803	0.61	1894	0.71	1995	0.83	2100	0.97	2206	1.12
2500	1890	0.70	1974	0.80	2068	0.92	2167	1.06	2268	1.21

CFM	AVAILABLE EXTERNAL STATIC PRESSURE (in. wg)									
	1.2		1.4		1.6		1.8		2.0	
	rpm	bhp	rpm	bhp	rpm	bhp	rpm	bhp	rpm	bhp
1500	1961	0.80	2079	0.96	2191	1.12	2297	1.29	—	—
1625	2004	0.85	2120	1.01	2229	1.18	2334	1.35	—	—
1750	2050	0.91	2163	1.07	2270	1.24	2373	1.41	—	—
1875	2098	0.97	2208	1.13	2314	1.31	—	—	—	—
2000	2148	1.04	2256	1.21	2359	1.38	—	—	—	—
2125	2200	1.11	2305	1.28	—	—	—	—	—	—
2250	2254	1.20	2357	1.37	—	—	—	—	—	—
2375	2310	1.28	—	—	—	—	—	—	—	—
2500	2368	1.38	—	—	—	—	—	—	—	—

Standard Static 1228-2150 rpm, 1.06 max bhp

Medium Static 1228-2390 rpm, 1.44 max bhp

### 50FCQA06 Single Phase — Standard Static — 5 Ton Vertical Supply (rpm - vdc)

CFM	AVAILABLE EXTERNAL STATIC PRESSURE (in. wg)									
	0.2		0.4		0.6		0.8		1.0	
	rpm	vdc	rpm	vdc	rpm	vdc	rpm	vdc	rpm	vdc
1500	1228	5.7	1394	6.5	1554	7.2	1701	7.9	1836	8.5
1625	1305	6.1	1457	6.8	1609	7.5	1750	8.1	1882	8.8
1750	1384	6.4	1523	7.1	1666	7.7	1802	8.4	1930	9.0
1875	1466	6.8	1592	7.4	1726	8.0	1857	8.6	1981	9.2
2000	1549	7.2	1664	7.7	1789	8.3	1914	8.9	2034	9.5
2125	1633	7.6	1739	8.1	1855	8.6	1974	9.2	2089	9.7
2250	1718	8.0	1816	8.4	1924	8.9	2036	9.5	2146	10.0
2375	1803	8.4	1894	8.8	1995	9.3	2100	9.8	—	—
2500	1890	8.8	1974	9.2	2068	9.6	—	—	—	—

CFM	AVAILABLE EXTERNAL STATIC PRESSURE (in. wg)									
	1.2		1.4		1.6		1.8		2.0	
	rpm	vdc	rpm	vdc	rpm	vdc	rpm	vdc	rpm	vdc
1500	1961	9.1	2079	9.7	—	—	—	—	—	—
1625	2004	9.3	2120	9.9	—	—	—	—	—	—
1750	2050	9.5	—	—	—	—	—	—	—	—
1875	2098	9.8	—	—	—	—	—	—	—	—
2000	2148	10.0	—	—	—	—	—	—	—	—
2125	—	—	—	—	—	—	—	—	—	—
2250	—	—	—	—	—	—	—	—	—	—
2375	—	—	—	—	—	—	—	—	—	—
2500	—	—	—	—	—	—	—	—	—	—

Standard Static 1228-2150 rpm

## APPENDIX C – FAN PERFORMANCE (cont)

### 50FCQA06 Single Phase – Medium Static – 5 Ton Vertical Supply (rpm - vdc)

CFM	AVAILABLE EXTERNAL STATIC PRESSURE (in. wg)									
	0.2		0.4		0.6		0.8		1.0	
	rpm	vdc	rpm	vdc	rpm	vdc	rpm	vdc	rpm	vdc
1500	1228	5.1	1394	5.8	1554	6.5	1701	7.1	1836	7.7
1625	1305	5.5	1457	6.1	1609	6.7	1750	7.3	1882	7.9
1750	1384	5.8	1523	6.4	1666	7.0	1802	7.5	1930	8.1
1875	1466	6.1	1592	6.7	1726	7.2	1857	7.8	1981	8.3
2000	1549	6.5	1664	7.0	1789	7.5	1914	8.0	2034	8.5
2125	1633	6.8	1739	7.3	1855	7.8	1974	8.3	2089	8.7
2250	1718	7.2	1816	7.6	1924	8.1	2036	8.5	2146	9.0
2375	1803	7.5	1894	7.9	1995	8.3	2100	8.8	2206	9.2
2500	1890	7.9	1974	8.3	2068	8.7	2167	9.1	2268	9.5

CFM	AVAILABLE EXTERNAL STATIC PRESSURE (in. wg)									
	1.2		1.4		1.6		1.8		2.0	
	rpm	vdc	rpm	vdc	rpm	vdc	rpm	vdc	rpm	vdc
1500	1961	8.2	2079	8.7	2191	9.2	2297	9.6	—	—
1625	2004	8.4	2120	8.9	2229	9.3	2334	9.8	—	—
1750	2050	8.6	2163	9.1	2270	9.5	2373	9.9	—	—
1875	2098	8.8	2208	9.2	2314	9.7	—	—	—	—
2000	2148	9.0	2256	9.4	2359	9.9	—	—	—	—
2125	2200	9.2	2305	9.6	—	—	—	—	—	—
2250	2254	9.4	2357	9.9	—	—	—	—	—	—
2375	2310	9.7	—	—	—	—	—	—	—	—
2500	2368	9.9	—	—	—	—	—	—	—	—

Medium Static 1228-2390 rpm



**APPENDIX C – FAN PERFORMANCE (cont)**

**50FCQA06 Three Phase – 5 Ton Vertical Supply (rpm - bhp)**

CFM	AVAILABLE EXTERNAL STATIC PRESSURE (in. wg)									
	0.2		0.4		0.6		0.8		1.0	
	rpm	bhp	rpm	bhp	rpm	bhp	rpm	bhp	rpm	bhp
1500	1228	0.20	1394	0.29	1554	0.40	1701	0.53	1836	0.66
1625	1305	0.24	1457	0.33	1609	0.44	1750	0.57	1882	0.71
1750	1384	0.28	1523	0.37	1666	0.49	1802	0.62	1930	0.76
1875	1466	0.33	1592	0.43	1726	0.54	1857	0.67	1981	0.82
2000	1549	0.39	1664	0.48	1789	0.60	1914	0.74	2034	0.88
2125	1633	0.46	1739	0.55	1855	0.67	1974	0.81	2089	0.95
2250	1718	0.53	1816	0.63	1924	0.74	2036	0.88	2146	1.03
2375	1803	0.61	1894	0.71	1995	0.83	2100	0.97	2206	1.12
2500	1889	0.70	1974	0.80	2068	0.92	2167	1.06	2268	1.21

CFM	AVAILABLE EXTERNAL STATIC PRESSURE (in. wg)									
	1.2		1.4		1.6		1.8		2.0	
	rpm	bhp	rpm	bhp	rpm	bhp	rpm	bhp	rpm	bhp
1500	1961	0.80	2079	0.96	2191	1.12	2297	1.29	2399	1.47
1625	2004	0.85	2120	1.01	2229	1.18	2334	1.35	2434	1.53
1750	2050	0.91	2163	1.07	2271	1.24	2373	1.41	2472	1.60
1875	2098	0.97	2208	1.13	2314	1.31	2415	1.48	2511	1.67
2000	2148	1.04	2256	1.21	2359	1.38	2458	1.56	2553	1.75
2125	2200	1.11	2305	1.28	2407	1.46	2504	1.64	2597	1.83
2250	2254	1.20	2357	1.37	2456	1.55	2551	1.73	2643	1.93
2375	2310	1.28	2410	1.46	2507	1.64	2600	1.83	2690	2.03
2500	2368	1.38	2465	1.56	2560	1.75	2651	1.94	2739	2.14

Standard Static 1228-2150 rpm, 1.06 max bhp

Medium Static 1228-2390 rpm, 1.44 max bhp

High Static 1228-2836 rpm, 2.43 max bhp

**50FCQA06 Three Phase – Standard Static – 5 Ton Vertical Supply (rpm - vdc)**

CFM	AVAILABLE EXTERNAL STATIC PRESSURE (in. wg)									
	0.2		0.4		0.6		0.8		1.0	
	rpm	vdc	rpm	vdc	rpm	vdc	rpm	vdc	rpm	vdc
1500	1228	5.7	1394	6.5	1554	7.2	1701	7.9	1836	8.5
1625	1305	6.1	1457	6.8	1609	7.5	1750	8.1	1882	8.8
1750	1384	6.4	1523	7.1	1666	7.7	1802	8.4	1930	9.0
1875	1466	6.8	1592	7.4	1726	8.0	1857	8.6	1981	9.2
2000	1549	7.2	1664	7.7	1789	8.3	1914	8.9	2034	9.5
2125	1633	7.6	1739	8.1	1855	8.6	1974	9.2	2089	9.7
2250	1718	8.0	1816	8.4	1924	8.9	2036	9.5	2146	10.0
2375	1803	8.4	1894	8.8	1995	9.3	2100	9.8	—	—
2500	1889	8.8	1974	9.2	2068	9.6	—	—	—	—

CFM	AVAILABLE EXTERNAL STATIC PRESSURE (in. wg)									
	1.2		1.4		1.6		1.8		2.0	
	rpm	vdc	rpm	vdc	rpm	vdc	rpm	vdc	rpm	vdc
1500	1961	9.1	2079	9.7	—	—	—	—	—	—
1625	2004	9.3	2120	9.9	—	—	—	—	—	—
1750	2050	9.5	—	—	—	—	—	—	—	—
1875	2098	9.8	—	—	—	—	—	—	—	—
2000	2148	10.0	—	—	—	—	—	—	—	—
2125	—	—	—	—	—	—	—	—	—	—
2250	—	—	—	—	—	—	—	—	—	—
2375	—	—	—	—	—	—	—	—	—	—
2500	—	—	—	—	—	—	—	—	—	—

Standard Static 1228-2150 rpm

## APPENDIX C – FAN PERFORMANCE (cont)

### 50FCQA06 Three Phase – Medium Static – 5 Ton Vertical Supply (rpm - vdc)

CFM	AVAILABLE EXTERNAL STATIC PRESSURE (in. wg)									
	0.2		0.4		0.6		0.8		1.0	
	rpm	vdc	rpm	vdc	rpm	vdc	rpm	vdc	rpm	vdc
1500	1228	5.1	1394	5.8	1554	6.5	1701	7.1	1836	7.7
1625	1305	5.5	1457	6.1	1609	6.7	1750	7.3	1882	7.9
1750	1384	5.8	1523	6.4	1666	7.0	1802	7.5	1930	8.1
1875	1466	6.1	1592	6.7	1726	7.2	1857	7.8	1981	8.3
2000	1549	6.5	1664	7.0	1789	7.5	1914	8.0	2034	8.5
2125	1633	6.8	1739	7.3	1855	7.8	1974	8.3	2089	8.7
2250	1718	7.2	1816	7.6	1924	8.1	2036	8.5	2146	9.0
2375	1803	7.5	1894	7.9	1995	8.3	2100	8.8	2206	9.2
2500	1889	7.9	1974	8.3	2068	8.7	2167	9.1	2268	9.5

CFM	AVAILABLE EXTERNAL STATIC PRESSURE (in. wg)									
	1.2		1.4		1.6		1.8		2.0	
	rpm	vdc	rpm	vdc	rpm	vdc	rpm	vdc	rpm	vdc
1500	1961	8.2	2079	8.7	2191	9.2	2297	9.6	—	—
1625	2004	8.4	2120	8.9	2229	9.3	2334	9.8	—	—
1750	2050	8.6	2163	9.1	2271	9.5	2373	9.9	—	—
1875	2098	8.8	2208	9.2	2314	9.7	—	—	—	—
2000	2148	9.0	2256	9.4	2359	9.9	—	—	—	—
2125	2200	9.2	2305	9.6	—	—	—	—	—	—
2250	2254	9.4	2357	9.9	—	—	—	—	—	—
2375	2310	9.7	—	—	—	—	—	—	—	—
2500	2368	9.9	—	—	—	—	—	—	—	—

Medium Static 1228-2390 rpm

### 50FCQA06 Three Phase – High Static – 5 Ton Vertical Supply (rpm - vdc)

CFM	AVAILABLE EXTERNAL STATIC PRESSURE (in. wg)									
	0.2		0.4		0.6		0.8		1.0	
	rpm	vdc	rpm	vdc	rpm	vdc	rpm	vdc	rpm	vdc
1500	1228	4.3	1394	4.9	1554	5.5	1701	6.0	1836	6.5
1625	1305	4.6	1457	5.1	1609	5.7	1750	6.2	1882	6.6
1750	1384	4.9	1523	5.4	1666	5.9	1802	6.4	1930	6.8
1875	1466	5.2	1592	5.6	1726	6.1	1857	6.5	1981	7.0
2000	1549	5.5	1664	5.9	1789	6.3	1914	6.7	2034	7.2
2125	1633	5.8	1739	6.1	1855	6.5	1974	7.0	2089	7.4
2250	1718	6.1	1816	6.4	1924	6.8	2036	7.2	2146	7.6
2375	1803	6.4	1894	6.7	1995	7.0	2100	7.4	2206	7.8
2500	1889	6.7	1974	7.0	2068	7.3	2167	7.6	2268	8.0

CFM	AVAILABLE EXTERNAL STATIC PRESSURE (in. wg)									
	1.2		1.4		1.6		1.8		2.0	
	rpm	vdc	rpm	vdc	rpm	vdc	rpm	vdc	rpm	vdc
1500	1961	6.9	2079	7.3	2191	7.7	2297	8.1	2399	8.5
1625	2004	7.1	2120	7.5	2229	7.9	2334	8.2	2434	8.6
1750	2050	7.2	2163	7.6	2271	8.0	2373	8.4	2472	8.7
1875	2098	7.4	2208	7.8	2314	8.2	2415	8.5	2511	8.9
2000	2148	7.6	2256	8.0	2359	8.3	2458	8.7	2553	9.0
2125	2200	7.8	2305	8.1	2407	8.5	2504	8.8	2597	9.2
2250	2254	7.9	2357	8.3	2456	8.7	2551	9.0	2643	9.3
2375	2310	8.1	2410	8.5	2507	8.8	2600	9.2	2690	9.5
2500	2368	8.3	2465	8.7	2560	9.0	2651	9.3	2739	9.7

High Static 1228-2836 rpm



**APPENDIX C – FAN PERFORMANCE (cont)**

**50FCQM07 Three Phase – 6 Ton Vertical Supply (rpm - bhp)**

CFM	AVAILABLE EXTERNAL STATIC PRESSURE (in. wg)									
	0.2		0.4		0.6		0.8		1.0	
	rpm	bhp	rpm	bhp	rpm	bhp	rpm	bhp	rpm	bhp
1800	1416	0.30	1549	0.39	1690	0.51	1824	0.64	1950	0.78
1950	1516	0.37	1635	0.46	1764	0.58	1891	0.71	2012	0.86
2100	1616	0.44	1724	0.54	1841	0.65	1961	0.79	2078	0.94
2250	1718	0.53	1815	0.62	1924	0.74	2036	0.88	2146	1.03
2400	1820	0.63	1910	0.73	2009	0.84	2113	0.98	2218	1.14
2550	1924	0.74	2007	0.84	2098	0.96	2195	1.10	2293	1.25
2700	2028	0.87	2105	0.97	2189	1.09	2279	1.23	2371	1.38
2850	2133	1.01	2205	1.11	2282	1.23	2366	1.37	2453	1.53
3000	2239	1.16	2306	1.27	2378	1.39	2456	1.53	2537	1.69

CFM	AVAILABLE EXTERNAL STATIC PRESSURE (in. wg)									
	1.2		1.4		1.6		1.8		2.0	
	rpm	bhp	rpm	bhp	rpm	bhp	rpm	bhp	rpm	bhp
1800	2069	0.93	2181	1.10	2287	1.26	2389	1.44	2487	1.62
1950	2127	1.01	2237	1.18	2341	1.35	2440	1.53	2536	1.71
2100	2189	1.10	2295	1.27	2397	1.44	2494	1.63	2588	1.82
2250	2254	1.20	2357	1.37	2456	1.55	2551	1.73	2643	1.93
2400	2321	1.30	2421	1.48	2517	1.66	2610	1.85	2700	2.05
2550	2392	1.42	2488	1.60	2581	1.79	2672	1.98	2759	2.18
2700	2465	1.55	2557	1.73	2648	1.93	2736	2.13	2821	2.33
2850	2541	1.70	2630	1.88	2717	2.08	2802	2.28	—	—
3000	2621	1.86	2705	2.05	2788	2.24	—	—	—	—

Standard Static 1416-2300 rpm, 1.31 max bhp

Medium Static 1416-2530 rpm, 1.76 max bhp

High Static 1416-2836 rpm, 2.43 max bhp

**50FCQM07 Three Phase – Standard Static – 6 Ton Vertical Supply (rpm - vdc)**

CFM	AVAILABLE EXTERNAL STATIC PRESSURE (in. wg)									
	0.2		0.4		0.6		0.8		1.0	
	rpm	vdc	rpm	vdc	rpm	vdc	rpm	vdc	rpm	vdc
1800	1416	6.2	1549	6.7	1690	7.3	1824	7.9	1950	8.5
1950	1516	6.6	1635	7.1	1764	7.7	1891	8.2	2012	8.7
2100	1616	7.0	1724	7.5	1841	8.0	1961	8.5	2078	9.0
2250	1718	7.5	1815	7.9	1924	8.4	2036	8.9	2146	9.3
2400	1820	7.9	1910	8.3	2009	8.7	2113	9.2	2218	9.6
2550	1924	8.4	2007	8.7	2098	9.1	2195	9.5	2293	10.0
2700	2028	8.8	2105	9.2	2189	9.5	2279	9.9	—	—
2850	2133	9.3	2205	9.6	2282	9.9	—	—	—	—
3000	2239	9.7	—	—	—	—	—	—	—	—

CFM	AVAILABLE EXTERNAL STATIC PRESSURE (in. wg)									
	1.2		1.4		1.6		1.8		2.0	
	rpm	vdc	rpm	vdc	rpm	vdc	rpm	vdc	rpm	vdc
1800	2069	9.0	2181	9.5	2287	9.9	—	—	—	—
1950	2127	9.2	2237	9.7	—	—	—	—	—	—
2100	2189	9.5	2295	10.0	—	—	—	—	—	—
2250	2254	9.8	—	—	—	—	—	—	—	—
2400	—	—	—	—	—	—	—	—	—	—
2550	—	—	—	—	—	—	—	—	—	—
2700	—	—	—	—	—	—	—	—	—	—
2850	—	—	—	—	—	—	—	—	—	—
3000	—	—	—	—	—	—	—	—	—	—

Standard Static 1416-2300 rpm

## APPENDIX C – FAN PERFORMANCE (cont)

### 50FCQM07 Three Phase – Medium Static – 6 Ton Vertical Supply (rpm - vdc)

CFM	AVAILABLE EXTERNAL STATIC PRESSURE (in. wg)									
	0.2		0.4		0.6		0.8		1.0	
	rpm	vdc	rpm	vdc	rpm	vdc	rpm	vdc	rpm	vdc
1800	1416	5.6	1549	6.1	1690	6.7	1824	7.2	1950	7.7
1950	1516	6.0	1635	6.5	1764	7.0	1891	7.5	2012	8.0
2100	1616	6.4	1724	6.8	1841	7.3	1961	7.8	2078	8.2
2250	1718	6.8	1815	7.2	1924	7.6	2036	8.0	2146	8.5
2400	1820	7.2	1910	7.5	2009	7.9	2113	8.4	2218	8.8
2550	1924	7.6	2007	7.9	2098	8.3	2195	8.7	2293	9.1
2700	2028	8.0	2105	8.3	2189	8.7	2279	9.0	2371	9.4
2850	2133	8.4	2205	8.7	2282	9.0	2366	9.4	2453	9.7
3000	2239	8.8	2306	9.1	2378	9.4	2456	9.7	—	—

CFM	AVAILABLE EXTERNAL STATIC PRESSURE (in. wg)									
	1.2		1.4		1.6		1.8		2.0	
	rpm	vdc	rpm	vdc	rpm	vdc	rpm	vdc	rpm	vdc
1800	2069	8.2	2181	8.6	2287	9.0	2389	9.4	2487	9.8
1950	2127	8.4	2237	8.8	2341	9.3	2440	9.6	—	—
2100	2189	8.7	2295	9.1	2397	9.5	2494	9.9	—	—
2250	2254	8.9	2357	9.3	2456	9.7	—	—	—	—
2400	2321	9.2	2421	9.6	2517	9.9	—	—	—	—
2550	2392	9.5	2488	9.8	—	—	—	—	—	—
2700	2465	9.7	—	—	—	—	—	—	—	—
2850	—	—	—	—	—	—	—	—	—	—
3000	—	—	—	—	—	—	—	—	—	—

Medium Static 1416-2530 rpm

### 50FCQM07 Three Phase – High Static – 6 Ton Vertical Supply (rpm - vdc)

CFM	AVAILABLE EXTERNAL STATIC PRESSURE (in. wg)									
	0.2		0.4		0.6		0.8		1.0	
	rpm	vdc	rpm	vdc	rpm	vdc	rpm	vdc	rpm	vdc
1800	1416	5.0	1549	5.5	1690	6.0	1824	6.4	1950	6.9
1950	1516	5.3	1635	5.8	1764	6.2	1891	6.7	2012	7.1
2100	1616	5.7	1724	6.1	1841	6.5	1961	6.9	2078	7.3
2250	1718	6.1	1815	6.4	1924	6.8	2036	7.2	2146	7.6
2400	1820	6.4	1910	6.7	2009	7.1	2113	7.5	2218	7.8
2550	1924	6.8	2007	7.1	2098	7.4	2195	7.7	2293	8.1
2700	2028	7.2	2105	7.4	2189	7.7	2279	8.0	2371	8.4
2850	2133	7.5	2205	7.8	2282	8.0	2366	8.3	2453	8.6
3000	2239	7.9	2306	8.1	2378	8.4	2456	8.7	2537	8.9

CFM	AVAILABLE EXTERNAL STATIC PRESSURE (in. wg)									
	1.2		1.4		1.6		1.8		2.0	
	rpm	vdc	rpm	vdc	rpm	vdc	rpm	vdc	rpm	vdc
1800	2069	7.3	2181	7.7	2287	8.1	2389	8.4	2487	8.8
1950	2127	7.5	2237	7.9	2341	8.3	2440	8.6	2536	8.9
2100	2189	7.7	2295	8.1	2397	8.5	2494	8.8	2588	9.1
2250	2254	7.9	2357	8.3	2456	8.7	2551	9.0	2643	9.3
2400	2321	8.2	2421	8.5	2517	8.9	2610	9.2	2700	9.5
2550	2392	8.4	2488	8.8	2581	9.1	2672	9.4	2759	9.7
2700	2465	8.7	2557	9.0	2648	9.3	2736	9.6	2821	9.9
2850	2541	9.0	2630	9.3	2717	9.6	2802	9.9	—	—
3000	2621	9.2	2705	9.5	2788	9.8	—	—	—	—

High Static 1416-2836 rpm

**APPENDIX C – FAN PERFORMANCE (cont)**

**50FCQA04 Single Phase – 3 Ton Horizontal Supply (rpm - bhp)**

CFM	AVAILABLE EXTERNAL STATIC PRESSURE (in. wg)									
	0.2		0.4		0.6		0.8		1.0	
	rpm	bhp	rpm	bhp	rpm	bhp	rpm	bhp	rpm	bhp
900	1036	0.08	1301	0.15	1517	0.24	1698	0.34	1855	0.44
975	1077	0.09	1331	0.16	1546	0.26	1727	0.36	1885	0.47
1050	1119	0.10	1362	0.18	1574	0.27	1755	0.38	1915	0.49
1125	1164	0.11	1394	0.19	1603	0.29	1783	0.39	1944	0.51
1200	1211	0.12	1429	0.20	1632	0.30	1813	0.41	1972	0.53
1275	1261	0.14	1466	0.22	1663	0.32	1841	0.43	2000	0.56
1350	1312	0.16	1506	0.24	1695	0.34	1870	0.46	2029	0.58
1425	1365	0.18	1547	0.26	1729	0.36	1901	0.48	2057	0.61
1500	1419	0.20	1591	0.28	1765	0.38	1932	0.50	2087	0.63

CFM	AVAILABLE EXTERNAL STATIC PRESSURE (in. wg)									
	1.2		1.4		1.6		1.8		2.0	
	rpm	bhp	rpm	bhp	rpm	bhp	rpm	bhp	rpm	bhp
900	1996	0.55	2123	0.67	2242	0.78	2352	0.91	2455	1.03
975	2027	0.58	2157	0.70	2276	0.82	2387	0.95	—	—
1050	2058	0.61	2189	0.73	2309	0.86	2421	0.99	—	—
1125	2088	0.63	2219	0.76	2341	0.89	2454	1.03	—	—
1200	2117	0.66	2249	0.79	2372	0.93	2486	1.07	—	—
1275	2146	0.69	2278	0.82	2402	0.97	—	—	—	—
1350	2174	0.72	2307	0.86	2431	1.00	—	—	—	—
1425	2202	0.74	2336	0.89	2460	1.04	—	—	—	—
1500	2230	0.77	2364	0.92	2488	1.07	—	—	—	—

Standard Static 1036-1890 rpm, 0.44 max bhp

Medium Static 1036-2190 rpm, 0.71 max bhp

High Static 1036-2490 rpm, 1.07 max bhp

**50FCQA04 Single Phase – Standard Static – 3 Ton Horizontal Supply (rpm - vdc)**

CFM	AVAILABLE EXTERNAL STATIC PRESSURE (in. wg)									
	0.2		0.4		0.6		0.8		1.0	
	rpm	vdc	rpm	vdc	rpm	vdc	rpm	vdc	rpm	vdc
900	1036	5.5	1301	6.9	1517	8.0	1698	9.0	1855	9.8
975	1077	5.7	1331	7.0	1546	8.2	1727	9.1	1885	10.0
1050	1119	5.9	1362	7.2	1574	8.3	1755	9.3	—	—
1125	1164	6.2	1394	7.4	1603	8.5	1783	9.4	—	—
1200	1211	6.4	1429	7.6	1632	8.6	1813	9.6	—	—
1275	1261	6.7	1466	7.8	1663	8.8	1841	9.7	—	—
1350	1312	6.9	1506	8.0	1695	9.0	1870	9.9	—	—
1425	1365	7.2	1547	8.2	1729	9.1	—	—	—	—
1500	1419	7.5	1591	8.4	1765	9.3	—	—	—	—

CFM	AVAILABLE EXTERNAL STATIC PRESSURE (in. wg)									
	1.2		1.4		1.6		1.8		2.0	
	rpm	vdc	rpm	vdc	rpm	vdc	rpm	vdc	rpm	vdc
900	—	—	—	—	—	—	—	—	—	—
975	—	—	—	—	—	—	—	—	—	—
1050	—	—	—	—	—	—	—	—	—	—
1125	—	—	—	—	—	—	—	—	—	—
1200	—	—	—	—	—	—	—	—	—	—
1275	—	—	—	—	—	—	—	—	—	—
1350	—	—	—	—	—	—	—	—	—	—
1425	—	—	—	—	—	—	—	—	—	—
1500	—	—	—	—	—	—	—	—	—	—

Standard Static 1036-1890 rpm

## APPENDIX C – FAN PERFORMANCE (cont)

### 50FCQA04 Single Phase – Medium Static – 3 Ton Horizontal Supply (rpm - vdc)

CFM	AVAILABLE EXTERNAL STATIC PRESSURE (in. wg)									
	0.2		0.4		0.6		0.8		1.0	
	rpm	vdc	rpm	vdc	rpm	vdc	rpm	vdc	rpm	vdc
900	1036	4.7	1301	5.9	1517	6.9	1698	7.8	1855	8.5
975	1077	4.9	1331	6.1	1546	7.1	1727	7.9	1885	8.6
1050	1119	5.1	1362	6.2	1574	7.2	1755	8.0	1915	8.7
1125	1164	5.3	1394	6.4	1603	7.3	1783	8.1	1944	8.9
1200	1211	5.5	1429	6.5	1632	7.5	1813	8.3	1972	9.0
1275	1261	5.8	1466	6.7	1663	7.6	1841	8.4	2000	9.1
1350	1312	6.0	1506	6.9	1695	7.7	1870	8.5	2029	9.3
1425	1365	6.2	1547	7.1	1729	7.9	1901	8.7	2057	9.4
1500	1419	6.5	1591	7.3	1765	8.1	1932	8.8	2087	9.5

CFM	AVAILABLE EXTERNAL STATIC PRESSURE (in. wg)									
	1.2		1.4		1.6		1.8		2.0	
	rpm	vdc	rpm	vdc	rpm	vdc	rpm	vdc	rpm	vdc
900	1996	9.1	2123	9.7	—	—	—	—	—	—
975	2027	9.3	2157	9.8	—	—	—	—	—	—
1050	2058	9.4	2189	10.0	—	—	—	—	—	—
1125	2088	9.5	—	—	—	—	—	—	—	—
1200	2117	9.7	—	—	—	—	—	—	—	—
1275	2146	9.8	—	—	—	—	—	—	—	—
1350	2174	9.9	—	—	—	—	—	—	—	—
1425	—	—	—	—	—	—	—	—	—	—
1500	—	—	—	—	—	—	—	—	—	—

Medium Static 1036-2190 rpm

### 50FCQA04 Single Phase – High Static – 3 Ton Horizontal Supply (rpm - vdc)

CFM	AVAILABLE EXTERNAL STATIC PRESSURE (in. wg)									
	0.2		0.4		0.6		0.8		1.0	
	rpm	vdc	rpm	vdc	rpm	vdc	rpm	vdc	rpm	vdc
900	1036	4.2	1301	5.2	1517	6.1	1698	6.8	1855	7.4
975	1077	4.3	1331	5.3	1546	6.2	1727	6.9	1885	7.6
1050	1119	4.5	1362	5.5	1574	6.3	1755	7.0	1915	7.7
1125	1164	4.7	1394	5.6	1603	6.4	1783	7.2	1944	7.8
1200	1211	4.9	1429	5.7	1632	6.6	1813	7.3	1972	7.9
1275	1261	5.1	1466	5.9	1663	6.7	1841	7.4	2000	8.0
1350	1312	5.3	1506	6.0	1695	6.8	1870	7.5	2029	8.1
1425	1365	5.5	1547	6.2	1729	6.9	1901	7.6	2057	8.3
1500	1419	5.7	1591	6.4	1765	7.1	1932	7.8	2087	8.4

CFM	AVAILABLE EXTERNAL STATIC PRESSURE (in. wg)									
	1.2		1.4		1.6		1.8		2.0	
	rpm	vdc	rpm	vdc	rpm	vdc	rpm	vdc	rpm	vdc
900	1996	8.0	2123	8.5	2242	9.0	2352	9.4	2455	9.9
975	2027	8.1	2157	8.7	2276	9.1	2387	9.6	—	—
1050	2058	8.3	2189	8.8	2309	9.3	2421	9.7	—	—
1125	2088	8.4	2219	8.9	2341	9.4	2454	9.9	—	—
1200	2117	8.5	2249	9.0	2372	9.5	2486	10.0	—	—
1275	2146	8.6	2278	9.1	2402	9.6	—	—	—	—
1350	2174	8.7	2307	9.3	2431	9.8	—	—	—	—
1425	2202	8.8	2336	9.4	2460	9.9	—	—	—	—
1500	2230	9.0	2364	9.5	2488	10.0	—	—	—	—

High Static 1036-2490 rpm



**APPENDIX C – FAN PERFORMANCE (cont)**

**50FCQA04 Three Phase – 3 Ton Horizontal Supply (rpm - bhp)**

CFM	AVAILABLE EXTERNAL STATIC PRESSURE (in. wg)									
	0.2		0.4		0.6		0.8		1.0	
	rpm	bhp	rpm	bhp	rpm	bhp	rpm	bhp	rpm	bhp
900	1036	0.08	1301	0.15	1517	0.24	1698	0.34	1855	0.44
975	1076	0.09	1330	0.16	1545	0.26	1727	0.36	1885	0.47
1050	1119	0.10	1361	0.18	1573	0.27	1756	0.38	1915	0.49
1125	1164	0.11	1395	0.19	1602	0.29	1784	0.40	1944	0.51
1200	1211	0.12	1429	0.20	1632	0.30	1812	0.41	1973	0.53
1275	1261	0.14	1466	0.22	1663	0.32	1841	0.43	2001	0.56
1350	1313	0.16	1506	0.24	1695	0.34	1870	0.46	2029	0.58
1425	1366	0.18	1548	0.26	1729	0.36	1900	0.48	2058	0.61
1500	1420	0.20	1591	0.28	1765	0.38	1932	0.50	2087	0.63

CFM	AVAILABLE EXTERNAL STATIC PRESSURE (in. wg)									
	1.2		1.4		1.6		1.8		2.0	
	rpm	bhp	rpm	bhp	rpm	bhp	rpm	bhp	rpm	bhp
900	1995	0.55	2124	0.67	2242	0.78	2352	0.91	2455	1.03
975	2027	0.58	2157	0.70	2276	0.82	2387	0.95	—	—
1050	2058	0.61	2189	0.73	2309	0.86	2421	0.99	—	—
1125	2088	0.63	2219	0.76	2341	0.89	2454	1.03	—	—
1200	2117	0.66	2249	0.79	2372	0.93	2485	1.07	—	—
1275	2146	0.69	2278	0.82	2401	0.96	—	—	—	—
1350	2174	0.72	2307	0.86	2431	1.00	—	—	—	—
1425	2202	0.74	2335	0.89	2460	1.04	—	—	—	—
1500	2231	0.77	2364	0.92	2488	1.07	—	—	—	—

Standard Static 1136-1890 rpm, 0.44 max bhp

Medium Static 1136-2190 rpm, 0.71 max bhp

High Static 1136-2490 rpm, 1.07 max bhp

**50FCQA04 Three Phase – Standard Static – 3 Ton Horizontal Supply (rpm - vdc)**

CFM	AVAILABLE EXTERNAL STATIC PRESSURE (in. wg)									
	0.2		0.4		0.6		0.8		1.0	
	rpm	vdc	rpm	vdc	rpm	vdc	rpm	vdc	rpm	vdc
900	1036	5.5	1301	6.9	1517	8.0	1698	9.0	1855	9.8
975	1076	5.7	1330	7.0	1545	8.2	1727	9.1	1885	10.0
1050	1119	5.9	1361	7.2	1573	8.3	1756	9.3	—	—
1125	1164	6.2	1395	7.4	1602	8.5	1784	9.4	—	—
1200	1211	6.4	1429	7.6	1632	8.6	1812	9.6	—	—
1275	1261	6.7	1466	7.8	1663	8.8	1841	9.7	—	—
1350	1313	6.9	1506	8.0	1695	9.0	1870	9.9	—	—
1425	1366	7.2	1548	8.2	1729	9.1	—	—	—	—
1500	1420	7.5	1591	8.4	1765	9.3	—	—	—	—

CFM	AVAILABLE EXTERNAL STATIC PRESSURE (in. wg)									
	1.2		1.4		1.6		1.8		2.0	
	rpm	vdc	rpm	vdc	rpm	vdc	rpm	vdc	rpm	vdc
900	—	—	—	—	—	—	—	—	—	—
975	—	—	—	—	—	—	—	—	—	—
1050	—	—	—	—	—	—	—	—	—	—
1125	—	—	—	—	—	—	—	—	—	—
1200	—	—	—	—	—	—	—	—	—	—
1275	—	—	—	—	—	—	—	—	—	—
1350	—	—	—	—	—	—	—	—	—	—
1425	—	—	—	—	—	—	—	—	—	—
1500	—	—	—	—	—	—	—	—	—	—

Standard Static 1136-1890 rpm

## APPENDIX C – FAN PERFORMANCE (cont)

### 50FCQA04 Three Phase – Medium Static – 3 Ton Horizontal Supply (rpm - vdc)

CFM	AVAILABLE EXTERNAL STATIC PRESSURE (in. wg)									
	0.2		0.4		0.6		0.8		1.0	
	rpm	vdc	rpm	vdc	rpm	vdc	rpm	vdc	rpm	vdc
900	1036	4.7	1301	5.9	1517	6.9	1698	7.8	1855	8.5
975	1076	4.9	1330	6.1	1545	7.1	1727	7.9	1885	8.6
1050	1119	5.1	1361	6.2	1573	7.2	1756	8.0	1915	8.7
1125	1164	5.3	1395	6.4	1602	7.3	1784	8.1	1944	8.9
1200	1211	5.5	1429	6.5	1632	7.5	1812	8.3	1973	9.0
1275	1261	5.8	1466	6.7	1663	7.6	1841	8.4	2001	9.1
1350	1313	6.0	1506	6.9	1695	7.7	1870	8.5	2029	9.3
1425	1366	6.2	1548	7.1	1729	7.9	1900	8.7	2058	9.4
1500	1420	6.5	1591	7.3	1765	8.1	1932	8.8	2087	9.5

CFM	AVAILABLE EXTERNAL STATIC PRESSURE (in. wg)									
	1.2		1.4		1.6		1.8		2.0	
	rpm	vdc	rpm	vdc	rpm	vdc	rpm	vdc	rpm	vdc
900	1995	9.1	2124	9.7	—	—	—	—	—	—
975	2027	9.3	2157	9.8	—	—	—	—	—	—
1050	2058	9.4	2189	10.0	—	—	—	—	—	—
1125	2088	9.5	—	—	—	—	—	—	—	—
1200	2117	9.7	—	—	—	—	—	—	—	—
1275	2146	9.8	—	—	—	—	—	—	—	—
1350	2174	9.9	—	—	—	—	—	—	—	—
1425	—	—	—	—	—	—	—	—	—	—
1500	—	—	—	—	—	—	—	—	—	—

Medium Static 1136-2190 rpm

### 50FCQA04 Three Phase – High Static – 3 Ton Horizontal Supply (rpm - vdc)

CFM	AVAILABLE EXTERNAL STATIC PRESSURE (in. wg)									
	0.2		0.4		0.6		0.8		1.0	
	rpm	vdc	rpm	vdc	rpm	vdc	rpm	vdc	rpm	vdc
900	1036	4.2	1301	5.2	1517	6.1	1698	6.8	1855	7.4
975	1076	4.3	1330	5.3	1545	6.2	1727	6.9	1885	7.6
1050	1119	4.5	1361	5.5	1573	6.3	1756	7.1	1915	7.7
1125	1164	4.7	1395	5.6	1602	6.4	1784	7.2	1944	7.8
1200	1211	4.9	1429	5.7	1632	6.6	1812	7.3	1973	7.9
1275	1261	5.1	1466	5.9	1663	6.7	1841	7.4	2001	8.0
1350	1313	5.3	1506	6.0	1695	6.8	1870	7.5	2029	8.1
1425	1366	5.5	1548	6.2	1729	6.9	1900	7.6	2058	8.3
1500	1420	5.7	1591	6.4	1765	7.1	1932	7.8	2087	8.4

CFM	AVAILABLE EXTERNAL STATIC PRESSURE (in. wg)									
	1.2		1.4		1.6		1.8		2.0	
	rpm	vdc	rpm	vdc	rpm	vdc	rpm	vdc	rpm	vdc
900	1995	8.0	2124	8.5	2242	9.0	2352	9.4	2455	9.9
975	2027	8.1	2157	8.7	2276	9.1	2387	9.6	—	—
1050	2058	8.3	2189	8.8	2309	9.3	2421	9.7	—	—
1125	2088	8.4	2219	8.9	2341	9.4	2454	9.9	—	—
1200	2117	8.5	2249	9.0	2372	9.5	2485	10.0	—	—
1275	2146	8.6	2278	9.1	2401	9.6	—	—	—	—
1350	2174	8.7	2307	9.3	2431	9.8	—	—	—	—
1425	2202	8.8	2335	9.4	2460	9.9	—	—	—	—
1500	2231	9.0	2364	9.5	2488	10.0	—	—	—	—

High Static 1136-2490 rpm

## APPENDIX C – FAN PERFORMANCE (cont)

### 50FCQC05 Single Phase – 4 Ton Horizontal Supply (rpm - bhp)

CFM	AVAILABLE EXTERNAL STATIC PRESSURE (in. wg)									
	0.2		0.4		0.6		0.8		1.0	
	rpm	bhp	rpm	bhp	rpm	bhp	rpm	bhp	rpm	bhp
1200	1066	0.13	1280	0.22	1473	0.34	1644	0.47	1798	0.61
1300	1120	0.15	1320	0.24	1506	0.36	1674	0.49	1826	0.64
1400	1177	0.17	1363	0.26	1541	0.38	1705	0.52	1856	0.67
1500	1236	0.20	1409	0.29	1579	0.41	1739	0.55	1886	0.70
1600	1297	0.23	1458	0.32	1620	0.44	1774	0.58	1918	0.73
1700	1359	0.26	1509	0.35	1663	0.47	1811	0.61	1952	0.77
1800	1423	0.30	1563	0.39	1708	0.51	1851	0.65	1987	0.81
1900	1487	0.34	1619	0.44	1756	0.56	1893	0.70	2025	0.85
2000	1552	0.38	1677	0.48	1806	0.60	1937	0.74	2064	0.90

CFM	AVAILABLE EXTERNAL STATIC PRESSURE (in. wg)									
	1.2		1.4		1.6		1.8		2.0	
	rpm	bhp	rpm	bhp	rpm	bhp	rpm	bhp	rpm	bhp
1200	1938	0.77	2069	0.93	2192	1.11	2309	1.29	2420	1.49
1300	1965	0.79	2095	0.96	2216	1.14	2331	1.33	2441	1.52
1400	1993	0.82	2121	0.99	2242	1.17	2356	1.36	—	—
1500	2023	0.86	2149	1.03	2269	1.21	2382	1.40	—	—
1600	2053	0.89	2178	1.07	2297	1.25	2409	1.45	—	—
1700	2084	0.93	2209	1.11	2326	1.30	2437	1.49	—	—
1800	2117	0.98	2239	1.15	2356	1.34	—	—	—	—
1900	2151	1.02	2272	1.20	2386	1.39	—	—	—	—
2000	2187	1.07	2305	1.25	2418	1.45	—	—	—	—

Standard Static 1066-1900 rpm, 0.72 max bhp

Medium Static 1066-2170 rpm, 1.06 max bhp

High Static 1066-2460 rpm, 1.53 max bhp

### 50FCQC05 Single Phase – Standard Static – 4 Ton Horizontal Supply (Rpm - vdc)

CFM	AVAILABLE EXTERNAL STATIC PRESSURE (in. wg)									
	0.2		0.4		0.6		0.8		1.0	
	rpm	vdc	rpm	vdc	rpm	vdc	rpm	vdc	rpm	vdc
1200	1066	5.6	1280	6.7	1473	7.8	1644	8.7	1798	9.5
1300	1120	5.9	1320	6.9	1506	7.9	1674	8.8	1826	9.6
1400	1177	6.2	1363	7.2	1541	8.1	1705	9.0	1856	9.8
1500	1236	6.5	1409	7.4	1579	8.3	1739	9.2	1886	9.9
1600	1297	6.8	1458	7.7	1620	8.5	1774	9.3	—	—
1700	1359	7.2	1509	7.9	1663	8.8	1811	9.5	—	—
1800	1423	7.5	1563	8.2	1708	9.0	1851	9.7	—	—
1900	1487	7.8	1619	8.5	1756	9.2	1893	10.0	—	—
2000	1552	8.2	1677	8.8	1806	9.5	—	—	—	—

CFM	AVAILABLE EXTERNAL STATIC PRESSURE (in. wg)									
	1.2		1.4		1.6		1.8		2.0	
	rpm	vdc	rpm	vdc	rpm	vdc	rpm	vdc	rpm	vdc
1200	—	—	—	—	—	—	—	—	—	—
1300	—	—	—	—	—	—	—	—	—	—
1400	—	—	—	—	—	—	—	—	—	—
1500	—	—	—	—	—	—	—	—	—	—
1600	—	—	—	—	—	—	—	—	—	—
1700	—	—	—	—	—	—	—	—	—	—
1800	—	—	—	—	—	—	—	—	—	—
1900	—	—	—	—	—	—	—	—	—	—
2000	—	—	—	—	—	—	—	—	—	—

Standard Static 1066-1900 rpm

## APPENDIX C – FAN PERFORMANCE (cont)

### 50FCQC05 Single Phase – Medium Static – 4 Ton Horizontal Supply (rpm - vdc)

CFM	AVAILABLE EXTERNAL STATIC PRESSURE (in. wg)									
	0.2		0.4		0.6		0.8		1.0	
	rpm	vdc	rpm	vdc	rpm	vdc	rpm	vdc	rpm	vdc
1200	1066	4.9	1280	5.9	1473	6.8	1644	7.6	1798	8.3
1300	1120	5.2	1320	6.1	1506	6.9	1674	7.7	1826	8.4
1400	1177	5.4	1363	6.3	1541	7.1	1705	7.9	1856	8.6
1500	1236	5.7	1409	6.5	1579	7.3	1739	8.0	1886	8.7
1600	1297	6.0	1458	6.7	1620	7.5	1774	8.2	1918	8.8
1700	1359	6.3	1509	7.0	1663	7.7	1811	8.3	1952	9.0
1800	1423	6.6	1563	7.2	1708	7.9	1851	8.5	1987	9.2
1900	1487	6.9	1619	7.5	1756	8.1	1893	8.7	2025	9.3
2000	1552	7.2	1677	7.7	1806	8.3	1937	8.9	2064	9.5

CFM	AVAILABLE EXTERNAL STATIC PRESSURE (in. wg)									
	1.2		1.4		1.6		1.8		2.0	
	rpm	vdc	rpm	vdc	rpm	vdc	rpm	vdc	rpm	vdc
1200	1938	8.9	2069	9.5	—	—	—	—	—	—
1300	1965	9.1	2095	9.7	—	—	—	—	—	—
1400	1993	9.2	2121	9.8	—	—	—	—	—	—
1500	2023	9.3	2149	9.9	—	—	—	—	—	—
1600	2053	9.5	—	—	—	—	—	—	—	—
1700	2084	9.6	—	—	—	—	—	—	—	—
1800	2117	9.8	—	—	—	—	—	—	—	—
1900	2151	9.9	—	—	—	—	—	—	—	—
2000	—	—	—	—	—	—	—	—	—	—

Medium Static 1066-2170 rpm

### 50FCQC05 Single Phase – High Static – 4 Ton Horizontal Supply (rpm - vdc)

CFM	AVAILABLE EXTERNAL STATIC PRESSURE (in. wg)									
	0.2		0.4		0.6		0.8		1.0	
	rpm	vdc	rpm	vdc	rpm	vdc	rpm	vdc	rpm	vdc
1200	1066	4.3	1280	5.2	1473	6.0	1644	6.7	1798	7.3
1300	1120	4.6	1320	5.4	1506	6.1	1674	6.8	1826	7.4
1400	1177	4.8	1363	5.5	1541	6.3	1705	6.9	1856	7.5
1500	1236	5.0	1409	5.7	1579	6.4	1739	7.1	1886	7.7
1600	1297	5.3	1458	5.9	1620	6.6	1774	7.2	1918	7.8
1700	1359	5.5	1509	6.1	1663	6.8	1811	7.4	1952	7.9
1800	1423	5.8	1563	6.4	1708	6.9	1851	7.5	1987	8.1
1900	1487	6.0	1619	6.6	1756	7.1	1893	7.7	2025	8.2
2000	1552	6.3	1677	6.8	1806	7.3	1937	7.9	2064	8.4

CFM	AVAILABLE EXTERNAL STATIC PRESSURE (in. wg)									
	1.2		1.4		1.6		1.8		2.0	
	rpm	vdc	rpm	vdc	rpm	vdc	rpm	vdc	rpm	vdc
1200	1938	7.9	2069	8.4	2192	8.9	2309	9.4	2420	9.8
1300	1965	8.0	2095	8.5	2216	9.0	2331	9.5	2441	9.9
1400	1993	8.1	2121	8.6	2242	9.1	2356	9.6	—	—
1500	2023	8.2	2149	8.7	2269	9.2	2382	9.7	—	—
1600	2053	8.3	2178	8.9	2297	9.3	2409	9.8	—	—
1700	2084	8.5	2209	9.0	2326	9.5	2437	9.9	—	—
1800	2117	8.6	2239	9.1	2356	9.6	—	—	—	—
1900	2151	8.7	2272	9.2	2386	9.7	—	—	—	—
2000	2187	8.9	2305	9.4	2418	9.8	—	—	—	—

High Static 1066-2460 rpm

**APPENDIX C — FAN PERFORMANCE (cont)**

**50FCQA05 Three Phase — 4 Ton Horizontal Supply (rpm - bhp)**

CFM	AVAILABLE EXTERNAL STATIC PRESSURE (in. wg)									
	0.2		0.4		0.6		0.8		1.0	
	rpm	bhp	rpm	bhp	rpm	bhp	rpm	bhp	rpm	bhp
1200	1067	0.13	1280	0.22	1473	0.34	1645	0.47	1798	0.61
1300	1121	0.15	1320	0.24	1506	0.36	1675	0.49	1827	0.64
1400	1177	0.17	1363	0.26	1542	0.38	1706	0.52	1856	0.67
1500	1237	0.20	1409	0.29	1579	0.41	1739	0.55	1887	0.70
1600	1297	0.23	1458	0.32	1620	0.44	1774	0.58	1919	0.73
1700	1359	0.26	1510	0.35	1663	0.47	1811	0.61	1952	0.77
1800	1423	0.30	1563	0.39	1708	0.51	1851	0.65	1988	0.81
1900	1487	0.34	1619	0.44	1756	0.56	1893	0.70	2025	0.85
2000	1552	0.38	1677	0.48	1807	0.60	1937	0.74	2064	0.90

CFM	AVAILABLE EXTERNAL STATIC PRESSURE (in. wg)									
	1.2		1.4		1.6		1.8		2.0	
	rpm	bhp	rpm	bhp	rpm	bhp	rpm	bhp	rpm	bhp
1200	1939	0.77	2070	0.93	2192	1.11	2309	1.29	2420	1.49
1300	1965	0.79	2095	0.96	2217	1.14	2332	1.33	2442	1.52
1400	1993	0.82	2121	0.99	2242	1.17	2356	1.36	2465	1.56
1500	2022	0.86	2149	1.03	2269	1.21	2382	1.40	2490	1.60
1600	2053	0.89	2178	1.07	2297	1.25	2409	1.45	2516	1.65
1700	2085	0.93	2208	1.11	2326	1.30	2437	1.49	2543	1.69
1800	2117	0.98	2240	1.16	2356	1.34	2466	1.54	2571	1.75
1900	2152	1.02	2272	1.20	2386	1.39	2496	1.59	2600	1.80
2000	2188	1.07	2306	1.25	2418	1.45	2526	1.65	2630	1.86

Standard Static 1067-1900 rpm, 0.72 max bhp

Medium Static 1067-2170 rpm, 1.06 max bhp

High Static 1067-2660 rpm, 1.96 max bhp

**50FCQA05 Three Phase — Standard Static — 4 Ton Horizontal Supply (rpm - vdc)**

CFM	AVAILABLE EXTERNAL STATIC PRESSURE (in. wg)									
	0.2		0.4		0.6		0.8		1.0	
	rpm	vdc	rpm	vdc	rpm	vdc	rpm	vdc	rpm	vdc
1200	1067	5.6	1280	6.7	1473	7.8	1645	8.7	1798	9.5
1300	1121	5.9	1320	6.9	1506	7.9	1675	8.8	1827	9.6
1400	1177	6.2	1363	7.2	1542	8.1	1706	9.0	1856	9.8
1500	1237	6.5	1409	7.4	1579	8.3	1739	9.2	1887	9.9
1600	1297	6.8	1458	7.7	1620	8.5	1774	9.3	—	—
1700	1359	7.2	1510	7.9	1663	8.8	1811	9.5	—	—
1800	1423	7.5	1563	8.2	1708	9.0	1851	9.7	—	—
1900	1487	7.8	1619	8.5	1756	9.2	1893	10.0	—	—
2000	1552	8.2	1677	8.8	1807	9.5	—	—	—	—

CFM	AVAILABLE EXTERNAL STATIC PRESSURE (in. wg)									
	1.2		1.4		1.6		1.8		2.0	
	rpm	vdc	rpm	vdc	rpm	vdc	rpm	vdc	rpm	vdc
1200	—	—	—	—	—	—	—	—	—	—
1300	—	—	—	—	—	—	—	—	—	—
1400	—	—	—	—	—	—	—	—	—	—
1500	—	—	—	—	—	—	—	—	—	—
1600	—	—	—	—	—	—	—	—	—	—
1700	—	—	—	—	—	—	—	—	—	—
1800	—	—	—	—	—	—	—	—	—	—
1900	—	—	—	—	—	—	—	—	—	—
2000	—	—	—	—	—	—	—	—	—	—

Standard Static 1067-1900 rpm



## APPENDIX C – FAN PERFORMANCE (cont)

### 50FCQA05 Three Phase – Medium Static – 4 Ton Horizontal Supply (rpm - vdc)

CFM	AVAILABLE EXTERNAL STATIC PRESSURE (in. wg)									
	0.2		0.4		0.6		0.8		1.0	
	rpm	vdc	rpm	vdc	rpm	vdc	rpm	vdc	rpm	vdc
1200	1067	4.9	1280	5.9	1473	6.8	1645	7.6	1798	8.3
1300	1121	5.2	1320	6.1	1506	6.9	1675	7.7	1827	8.4
1400	1177	5.4	1363	6.3	1542	7.1	1706	7.9	1856	8.6
1500	1237	5.7	1409	6.5	1579	7.3	1739	8.0	1887	8.7
1600	1297	6.0	1458	6.7	1620	7.5	1774	8.2	1919	8.8
1700	1359	6.3	1510	7.0	1663	7.7	1811	8.3	1952	9.0
1800	1423	6.6	1563	7.2	1708	7.9	1851	8.5	1988	9.2
1900	1487	6.9	1619	7.5	1756	8.1	1893	8.7	2025	9.3
2000	1552	7.2	1677	7.7	1807	8.3	1937	8.9	2064	9.5

CFM	AVAILABLE EXTERNAL STATIC PRESSURE (in. wg)									
	1.2		1.4		1.6		1.8		2.0	
	rpm	vdc	rpm	vdc	rpm	vdc	rpm	vdc	rpm	vdc
1200	1939	8.9	2070	9.5	—	—	—	—	—	—
1300	1965	9.1	2095	9.7	—	—	—	—	—	—
1400	1993	9.2	2121	9.8	—	—	—	—	—	—
1500	2022	9.3	2149	9.9	—	—	—	—	—	—
1600	2053	9.5	—	—	—	—	—	—	—	—
1700	2085	9.6	—	—	—	—	—	—	—	—
1800	2117	9.8	—	—	—	—	—	—	—	—
1900	2152	9.9	—	—	—	—	—	—	—	—
2000	—	—	—	—	—	—	—	—	—	—

Medium Static 1067-2170 rpm

### 50FCQA05 Three Phase – High Static – 4 Ton Horizontal Supply (rpm - vdc)

CFM	AVAILABLE EXTERNAL STATIC PRESSURE (in. wg)									
	0.2		0.4		0.6		0.8		1.0	
	rpm	vdc	rpm	vdc	rpm	vdc	rpm	vdc	rpm	vdc
1200	1067	4.0	1280	4.8	1473	5.5	1645	6.2	1798	6.8
1300	1121	4.2	1320	5.0	1506	5.7	1675	6.3	1827	6.9
1400	1177	4.4	1363	5.1	1542	5.8	1706	6.4	1856	7.0
1500	1237	4.7	1409	5.3	1579	5.9	1739	6.5	1887	7.1
1600	1297	4.9	1458	5.5	1620	6.1	1774	6.7	1919	7.2
1700	1359	5.1	1510	5.7	1663	6.3	1811	6.8	1952	7.3
1800	1423	5.3	1563	5.9	1708	6.4	1851	7.0	1988	7.5
1900	1487	5.6	1619	6.1	1756	6.6	1893	7.1	2025	7.6
2000	1552	5.8	1677	6.3	1807	6.8	1937	7.3	2064	7.8

CFM	AVAILABLE EXTERNAL STATIC PRESSURE (in. wg)									
	1.2		1.4		1.6		1.8		2.0	
	rpm	vdc	rpm	vdc	rpm	vdc	rpm	vdc	rpm	vdc
1200	1939	7.3	2070	7.8	2192	8.2	2309	8.7	2420	9.1
1300	1965	7.4	2095	7.9	2217	8.3	2332	8.8	2442	9.2
1400	1993	7.5	2121	8.0	2242	8.4	2356	8.9	2465	9.3
1500	2022	7.6	2149	8.1	2269	8.5	2382	9.0	2490	9.4
1600	2053	7.7	2178	8.2	2297	8.6	2409	9.1	2516	9.5
1700	2085	7.8	2208	8.3	2326	8.7	2437	9.2	2543	9.6
1800	2117	8.0	2240	8.4	2356	8.9	2466	9.3	2571	9.7
1900	2152	8.1	2272	8.5	2386	9.0	2496	9.4	2600	9.8
2000	2188	8.2	2306	8.7	2418	9.1	2526	9.5	2630	9.9

High Static 1067-2660 rpm

**APPENDIX C – FAN PERFORMANCE (cont)**

**50FCQA06 Single Phase – 5 Ton Horizontal Supply (rpm - bhp)**

CFM	AVAILABLE EXTERNAL STATIC PRESSURE (in. wg)									
	0.2		0.4		0.6		0.8		1.0	
	rpm	bhp	rpm	bhp	rpm	bhp	rpm	bhp	rpm	bhp
1500	1197	0.18	1360	0.26	1525	0.37	1679	0.49	1822	0.62
1625	1271	0.21	1421	0.29	1574	0.40	1721	0.52	1860	0.66
1750	1348	0.25	1485	0.33	1627	0.44	1767	0.56	1901	0.70
1875	1425	0.29	1553	0.38	1684	0.49	1817	0.61	1945	0.75
2000	1504	0.35	1623	0.43	1745	0.54	1870	0.66	1992	0.80
2125	1585	0.40	1695	0.49	1809	0.60	1926	0.72	2043	0.86
2250	1666	0.47	1769	0.56	1876	0.67	1986	0.79	2096	0.93
2375	1747	0.54	1844	0.63	1945	0.74	2049	0.87	2153	1.01
2500	1830	0.62	1921	0.71	2016	0.82	2114	0.95	2213	1.09

CFM	AVAILABLE EXTERNAL STATIC PRESSURE (in. wg)									
	1.2		1.4		1.6		1.8		2.0	
	rpm	bhp	rpm	bhp	rpm	bhp	rpm	bhp	rpm	bhp
1500	1954	0.77	2078	0.92	2194	1.09	2304	1.26	—	—
1625	1990	0.81	2112	0.97	2227	1.13	2336	1.31	—	—
1750	2028	0.85	2148	1.01	2262	1.18	2370	1.36	—	—
1875	2069	0.90	2186	1.06	2298	1.23	—	—	—	—
2000	2111	0.95	2226	1.12	2336	1.29	—	—	—	—
2125	2157	1.02	2268	1.18	2375	1.36	—	—	—	—
2250	2206	1.08	2313	1.25	—	—	—	—	—	—
2375	2258	1.16	2361	1.33	—	—	—	—	—	—
2500	2312	1.24	—	—	—	—	—	—	—	—

Standard Static 1197-2150 rpm, 1.06 max bhp

Medium Static 1197-2390 rpm, 1.44 max bhp

**50FCQA06 Single Phase – Standard Static – 5 Ton Horizontal Supply (rpm - vdc)**

CFM	AVAILABLE EXTERNAL STATIC PRESSURE (in. wg)									
	0.2		0.4		0.6		0.8		1.0	
	rpm	vdc	rpm	vdc	rpm	vdc	rpm	vdc	rpm	vdc
1500	1197	5.6	1360	6.3	1525	7.1	1679	7.8	1822	8.5
1625	1271	5.9	1421	6.6	1574	7.3	1721	8.0	1860	8.7
1750	1348	6.3	1485	6.9	1627	7.6	1767	8.2	1901	8.8
1875	1425	6.6	1553	7.2	1684	7.8	1817	8.5	1945	9.0
2000	1504	7.0	1623	7.5	1745	8.1	1870	8.7	1992	9.3
2125	1585	7.4	1695	7.9	1809	8.4	1926	9.0	2043	9.5
2250	1666	7.7	1769	8.2	1876	8.7	1986	9.2	2096	9.7
2375	1747	8.1	1844	8.6	1945	9.0	2049	9.5	—	—
2500	1830	8.5	1921	8.9	2016	9.4	2114	9.8	—	—

CFM	AVAILABLE EXTERNAL STATIC PRESSURE (in. wg)									
	1.2		1.4		1.6		1.8		2.0	
	rpm	vdc	rpm	vdc	rpm	vdc	rpm	vdc	rpm	vdc
1500	1954	9.1	2078	9.7	—	—	—	—	—	—
1625	1990	9.3	2112	9.8	—	—	—	—	—	—
1750	2028	9.4	2148	10.0	—	—	—	—	—	—
1875	2069	9.6	—	—	—	—	—	—	—	—
2000	2111	9.8	—	—	—	—	—	—	—	—
2125	—	—	—	—	—	—	—	—	—	—
2250	—	—	—	—	—	—	—	—	—	—
2375	—	—	—	—	—	—	—	—	—	—
2500	—	—	—	—	—	—	—	—	—	—

Standard Static 1197-2150 rpm

## APPENDIX C – FAN PERFORMANCE (cont)

### 50FCQA06 Single Phase – Medium Static – 5 Ton Horizontal Supply (rpm - vdc)

CFM	AVAILABLE EXTERNAL STATIC PRESSURE (in. wg)									
	0.2		0.4		0.6		0.8		1.0	
	rpm	vdc	rpm	vdc	rpm	vdc	rpm	vdc	rpm	vdc
1500	1197	5.0	1360	5.7	1525	6.4	1679	7.0	1822	7.6
1625	1271	5.3	1421	5.9	1574	6.6	1721	7.2	1860	7.8
1750	1348	5.6	1485	6.2	1627	6.8	1767	7.4	1901	8.0
1875	1425	6.0	1553	6.5	1684	7.0	1817	7.6	1945	8.1
2000	1504	6.3	1623	6.8	1745	7.3	1870	7.8	1992	8.3
2125	1585	6.6	1695	7.1	1809	7.6	1926	8.1	2043	8.5
2250	1666	7.0	1769	7.4	1876	7.8	1986	8.3	2096	8.8
2375	1747	7.3	1844	7.7	1945	8.1	2049	8.6	2153	9.0
2500	1830	7.7	1921	8.0	2016	8.4	2114	8.8	2213	9.3

CFM	AVAILABLE EXTERNAL STATIC PRESSURE (in. wg)									
	1.2		1.4		1.6		1.8		2.0	
	rpm	vdc	rpm	vdc	rpm	vdc	rpm	vdc	rpm	vdc
1500	1954	8.2	2078	8.7	2194	9.2	2304	9.6	—	—
1625	1990	8.3	2112	8.8	2227	9.3	2336	9.8	—	—
1750	2028	8.5	2148	9.0	2262	9.5	2370	9.9	—	—
1875	2069	8.7	2186	9.1	2298	9.6	—	—	—	—
2000	2111	8.8	2226	9.3	2336	9.8	—	—	—	—
2125	2157	9.0	2268	9.5	2375	9.9	—	—	—	—
2250	2206	9.2	2313	9.7	—	—	—	—	—	—
2375	2258	9.4	2361	9.9	—	—	—	—	—	—
2500	2312	9.7	—	—	—	—	—	—	—	—

Medium Static 1197-2390 rpm



**APPENDIX C – FAN PERFORMANCE (cont)**

**50FCQA06 Three Phase – 5 Ton Horizontal Supply (rpm - bhp)**

CFM	AVAILABLE EXTERNAL STATIC PRESSURE (in. wg)									
	0.2		0.4		0.6		0.8		1.0	
	rpm	bhp	rpm	bhp	rpm	bhp	rpm	bhp	rpm	bhp
1500	1196	0.18	1360	0.26	1525	0.37	1679	0.49	1822	0.62
1625	1271	0.21	1421	0.29	1574	0.40	1721	0.52	1860	0.66
1750	1348	0.25	1485	0.33	1627	0.44	1767	0.56	1901	0.70
1875	1425	0.29	1553	0.38	1684	0.49	1817	0.61	1945	0.75
2000	1504	0.35	1622	0.43	1745	0.54	1870	0.66	1993	0.80
2125	1585	0.40	1695	0.49	1809	0.60	1926	0.72	2043	0.86
2250	1666	0.47	1769	0.56	1876	0.67	1986	0.79	2096	0.93
2375	1747	0.54	1844	0.63	1945	0.74	2049	0.87	2153	1.01
2500	1829	0.62	1921	0.71	2016	0.82	2114	0.95	2213	1.09

CFM	AVAILABLE EXTERNAL STATIC PRESSURE (in. wg)									
	1.2		1.4		1.6		1.8		2.0	
	rpm	bhp	rpm	bhp	rpm	bhp	rpm	bhp	rpm	bhp
1500	1954	0.77	2078	0.92	2194	1.09	2304	1.26	2408	1.44
1625	1990	0.81	2112	0.97	2227	1.13	2336	1.31	2439	1.49
1750	2028	0.85	2148	1.01	2262	1.18	2370	1.36	2472	1.54
1875	2069	0.90	2186	1.06	2298	1.23	2404	1.41	2506	1.60
2000	2112	0.96	2226	1.12	2336	1.29	2441	1.48	2541	1.66
2125	2157	1.02	2268	1.18	2376	1.36	2479	1.54	2578	1.73
2250	2206	1.08	2313	1.25	2418	1.43	2518	1.61	2616	1.81
2375	2258	1.16	2361	1.33	2462	1.50	2560	1.69	2656	1.89
2500	2312	1.24	2411	1.41	2508	1.59	2604	1.78	2698	1.97

Standard Static 1196-2150 rpm, 1.06 max bhp

Medium Static 1196-2390 rpm, 1.44 max bhp

High Static 1196-2836 rpm, 2.43 max bhp

**50FCQA06 Three Phase – Standard Static – 5 Ton Horizontal Supply (rpm - vdc)**

CFM	AVAILABLE EXTERNAL STATIC PRESSURE (in. wg)									
	0.2		0.4		0.6		0.8		1.0	
	rpm	vdc	rpm	vdc	rpm	vdc	rpm	vdc	rpm	vdc
1500	1196	5.6	1360	6.3	1525	7.1	1679	7.8	1822	8.5
1625	1271	5.9	1421	6.6	1574	7.3	1721	8.0	1860	8.7
1750	1348	6.3	1485	6.9	1627	7.6	1767	8.2	1901	8.8
1875	1425	6.6	1553	7.2	1684	7.8	1817	8.5	1945	9.0
2000	1504	7.0	1622	7.5	1745	8.1	1870	8.7	1993	9.3
2125	1585	7.4	1695	7.9	1809	8.4	1926	9.0	2043	9.5
2250	1666	7.7	1769	8.2	1876	8.7	1986	9.2	2096	9.7
2375	1747	8.1	1844	8.6	1945	9.0	2049	9.5	—	—
2500	1829	8.5	1921	8.9	2016	9.4	2114	9.8	—	—

CFM	AVAILABLE EXTERNAL STATIC PRESSURE (in. wg)									
	1.2		1.4		1.6		1.8		2.0	
	rpm	vdc	rpm	vdc	rpm	vdc	rpm	vdc	rpm	vdc
1500	1954	9.1	2078	9.7	—	—	—	—	—	—
1625	1990	9.3	2112	9.8	—	—	—	—	—	—
1750	2028	9.4	2148	10.0	—	—	—	—	—	—
1875	2069	9.6	—	—	—	—	—	—	—	—
2000	2112	9.8	—	—	—	—	—	—	—	—
2125	—	—	—	—	—	—	—	—	—	—
2250	—	—	—	—	—	—	—	—	—	—
2375	—	—	—	—	—	—	—	—	—	—
2500	—	—	—	—	—	—	—	—	—	—

Standard Static 1196-2150 rpm

## APPENDIX C – FAN PERFORMANCE (cont)

### 50FCQA06 Three Phase – Medium Static – 5 Ton Horizontal Supply (rpm - vdc)

CFM	AVAILABLE EXTERNAL STATIC PRESSURE (in. wg)									
	0.2		0.4		0.6		0.8		1.0	
	rpm	vdc	rpm	vdc	rpm	vdc	rpm	vdc	rpm	vdc
1500	1196	5.0	1360	5.7	1525	6.4	1679	7.0	1822	7.6
1625	1271	5.3	1421	5.9	1574	6.6	1721	7.2	1860	7.8
1750	1348	5.6	1485	6.2	1627	6.8	1767	7.4	1901	8.0
1875	1425	6.0	1553	6.5	1684	7.0	1817	7.6	1945	8.1
2000	1504	6.3	1622	6.8	1745	7.3	1870	7.8	1993	8.3
2125	1585	6.6	1695	7.1	1809	7.6	1926	8.1	2043	8.5
2250	1666	7.0	1769	7.4	1876	7.8	1986	8.3	2096	8.8
2375	1747	7.3	1844	7.7	1945	8.1	2049	8.6	2153	9.0
2500	1829	7.7	1921	8.0	2016	8.4	2114	8.8	2213	9.3

CFM	AVAILABLE EXTERNAL STATIC PRESSURE (in. wg)									
	1.2		1.4		1.6		1.8		2.0	
	rpm	vdc	rpm	vdc	rpm	vdc	rpm	vdc	rpm	vdc
1500	1954	8.2	2078	8.7	2194	9.2	2304	9.6	—	—
1625	1990	8.3	2112	8.8	2227	9.3	2336	9.8	—	—
1750	2028	8.5	2148	9.0	2262	9.5	2370	9.9	—	—
1875	2069	8.7	2186	9.1	2298	9.6	—	—	—	—
2000	2112	8.8	2226	9.3	2336	9.8	—	—	—	—
2125	2157	9.0	2268	9.5	2376	9.9	—	—	—	—
2250	2206	9.2	2313	9.7	—	—	—	—	—	—
2375	2258	9.4	2361	9.9	—	—	—	—	—	—
2500	2312	9.7	—	—	—	—	—	—	—	—

Medium Static 1196-2390 rpm

### 50FCQA06 Three Phase – High Static – 5 Ton Horizontal Supply (rpm - vdc)

CFM	AVAILABLE EXTERNAL STATIC PRESSURE (in. wg)									
	0.2		0.4		0.6		0.8		1.0	
	rpm	vdc	rpm	vdc	rpm	vdc	rpm	vdc	rpm	vdc
1500	1196	4.2	1360	4.8	1525	5.4	1679	5.9	1822	6.4
1625	1271	4.5	1421	5.0	1574	5.6	1721	6.1	1860	6.6
1750	1348	4.8	1485	5.2	1627	5.7	1767	6.2	1901	6.7
1875	1425	5.0	1553	5.5	1684	5.9	1817	6.4	1945	6.9
2000	1504	5.3	1622	5.7	1745	6.2	1870	6.6	1993	7.0
2125	1585	5.6	1695	6.0	1809	6.4	1926	6.8	2043	7.2
2250	1666	5.9	1769	6.2	1876	6.6	1986	7.0	2096	7.4
2375	1747	6.2	1844	6.5	1945	6.9	2049	7.2	2153	7.6
2500	1829	6.4	1921	6.8	2016	7.1	2114	7.5	2213	7.8

CFM	AVAILABLE EXTERNAL STATIC PRESSURE (in. wg)									
	1.2		1.4		1.6		1.8		2.0	
	rpm	vdc	rpm	vdc	rpm	vdc	rpm	vdc	rpm	vdc
1500	1954	6.9	2078	7.3	2194	7.7	2304	8.1	2408	8.5
1625	1990	7.0	2112	7.4	2227	7.9	2336	8.2	2439	8.6
1750	2028	7.2	2148	7.6	2262	8.0	2370	8.4	2472	8.7
1875	2069	7.3	2186	7.7	2298	8.1	2404	8.5	2506	8.8
2000	2112	7.4	2226	7.8	2336	8.2	2441	8.6	2541	9.0
2125	2157	7.6	2268	8.0	2376	8.4	2479	8.7	2578	9.1
2250	2206	7.8	2313	8.2	2418	8.5	2518	8.9	2616	9.2
2375	2258	8.0	2361	8.3	2462	8.7	2560	9.0	2656	9.4
2500	2312	8.2	2411	8.5	2508	8.8	2604	9.2	2698	9.5

High Static 1196-2836 rpm



**APPENDIX C – FAN PERFORMANCE (cont)**

**50FCQM07 Three Phase – 6 Ton Horizontal Supply (rpm - bhp)**

CFM	AVAILABLE EXTERNAL STATIC PRESSURE (in. wg)									
	0.2		0.4		0.6		0.8		1.0	
	rpm	bhp	rpm	bhp	rpm	bhp	rpm	bhp	rpm	bhp
1800	1378	0.27	1512	0.35	1649	0.46	1786	0.58	1918	0.72
1950	1473	0.32	1594	0.41	1721	0.52	1848	0.64	1973	0.78
2100	1569	0.39	1680	0.48	1796	0.59	1915	0.71	2032	0.85
2250	1666	0.47	1769	0.56	1876	0.67	1986	0.79	2096	0.93
2400	1764	0.55	1860	0.65	1959	0.76	2061	0.88	2165	1.02
2550	1863	0.65	1952	0.75	2045	0.86	2140	0.99	2237	1.13
2700	1962	0.76	2046	0.86	2133	0.97	2222	1.10	2313	1.24
2850	2062	0.88	2141	0.98	2223	1.10	2307	1.23	2392	1.37
3000	2163	1.01	2238	1.12	2315	1.24	2394	1.37	2474	1.52

CFM	AVAILABLE EXTERNAL STATIC PRESSURE (in. wg)									
	1.2		1.4		1.6		1.8		2.0	
	rpm	bhp	rpm	bhp	rpm	bhp	rpm	bhp	rpm	bhp
1800	2044	0.87	2163	1.03	2276	1.20	2383	1.38	2486	1.57
1950	2094	0.93	2210	1.10	2320	1.27	2426	1.45	2527	1.64
2100	2148	1.00	2259	1.17	2367	1.34	2471	1.53	2570	1.72
2250	2206	1.08	2313	1.25	2417	1.43	2518	1.61	2616	1.81
2400	2268	1.18	2370	1.34	2471	1.52	2568	1.71	2664	1.90
2550	2335	1.28	2432	1.45	2528	1.62	2622	1.81	2714	2.01
2700	2405	1.40	2497	1.56	2589	1.74	2679	1.93	2768	2.13
2850	2479	1.53	2566	1.69	2653	1.87	2740	2.06	2826	2.26
3000	2556	1.67	2639	1.84	2722	2.02	2804	2.21	—	—

Standard Static 1378-2300 rpm, 1.31 max bhp

Medium Static 1378-2530 rpm, 1.76 max bhp

High Static 1378-2836 rpm, 2.43 max bhp

**50FCQM07 Three Phase – Standard Static – 6 Ton Horizontal Supply (rpm - vdc)**

CFM	AVAILABLE EXTERNAL STATIC PRESSURE (in. wg)									
	0.2		0.4		0.6		0.8		1.0	
	rpm	vdc	rpm	vdc	rpm	vdc	rpm	vdc	rpm	vdc
1800	1378	6.0	1512	6.6	1649	7.2	1786	7.8	1918	8.3
1950	1473	6.4	1594	6.9	1721	7.5	1848	8.0	1973	8.6
2100	1569	6.8	1680	7.3	1796	7.8	1915	8.3	2032	8.8
2250	1666	7.2	1769	7.7	1876	8.2	1986	8.6	2096	9.1
2400	1764	7.7	1860	8.1	1959	8.5	2061	9.0	2165	9.4
2550	1863	8.1	1952	8.5	2045	8.9	2140	9.3	2237	9.7
2700	1962	8.5	2046	8.9	2133	9.3	2222	9.7	—	—
2850	2062	9.0	2141	9.3	2223	9.7	—	—	—	—
3000	2163	9.4	2238	9.7	—	—	—	—	—	—

CFM	AVAILABLE EXTERNAL STATIC PRESSURE (in. wg)									
	1.2		1.4		1.6		1.8		2.0	
	rpm	vdc	rpm	vdc	rpm	vdc	rpm	vdc	rpm	vdc
1800	2044	8.9	2163	9.4	2276	9.9	—	—	—	—
1950	2094	9.1	2210	9.6	—	—	—	—	—	—
2100	2148	9.3	2259	9.8	—	—	—	—	—	—
2250	2206	9.6	—	—	—	—	—	—	—	—
2400	2268	9.9	—	—	—	—	—	—	—	—
2550	—	—	—	—	—	—	—	—	—	—
2700	—	—	—	—	—	—	—	—	—	—
2850	—	—	—	—	—	—	—	—	—	—
3000	—	—	—	—	—	—	—	—	—	—

Standard Static 1378-2300 rpm

## APPENDIX C – FAN PERFORMANCE (cont)

### 50FCQM07 Three Phase – Medium Static – 6 Ton Horizontal Supply (rpm - vdc)

CFM	AVAILABLE EXTERNAL STATIC PRESSURE (in. wg)									
	0.2		0.4		0.6		0.8		1.0	
	rpm	vdc	rpm	vdc	rpm	vdc	rpm	vdc	rpm	vdc
1800	1378	5.4	1512	6.0	1649	6.5	1786	7.1	1918	7.6
1950	1473	5.8	1594	6.3	1721	6.8	1848	7.3	1973	7.8
2100	1569	6.2	1680	6.6	1796	7.1	1915	7.6	2032	8.0
2250	1666	6.6	1769	7.0	1876	7.4	1986	7.8	2096	8.3
2400	1764	7.0	1860	7.4	1959	7.7	2061	8.1	2165	8.6
2550	1863	7.4	1952	7.7	2045	8.1	2140	8.5	2237	8.8
2700	1962	7.8	2046	8.1	2133	8.4	2222	8.8	2313	9.1
2850	2062	8.2	2141	8.5	2223	8.8	2307	9.1	2392	9.5
3000	2163	8.5	2238	8.8	2315	9.2	2394	9.5	2474	9.8

CFM	AVAILABLE EXTERNAL STATIC PRESSURE (in. wg)									
	1.2		1.4		1.6		1.8		2.0	
	rpm	vdc	rpm	vdc	rpm	vdc	rpm	vdc	rpm	vdc
1800	2044	8.1	2163	8.5	2276	9.0	2383	9.4	2486	9.8
1950	2094	8.3	2210	8.7	2320	9.2	2426	9.6	2527	10.0
2100	2148	8.5	2259	8.9	2367	9.4	2471	9.8	—	—
2250	2206	8.7	2313	9.1	2417	9.6	2518	10.0	—	—
2400	2268	9.0	2370	9.4	2471	9.8	—	—	—	—
2550	2335	9.2	2432	9.6	2528	10.0	—	—	—	—
2700	2405	9.5	2497	9.9	—	—	—	—	—	—
2850	2479	9.8	—	—	—	—	—	—	—	—
3000	—	—	—	—	—	—	—	—	—	—

Medium Static 1378-2530 rpm

### 50FCQM07 Three Phase – High Static – 6 Ton Horizontal Supply (rpm - vdc)

CFM	AVAILABLE EXTERNAL STATIC PRESSURE (in. wg)									
	0.2		0.4		0.6		0.8		1.0	
	rpm	vdc	rpm	vdc	rpm	vdc	rpm	vdc	rpm	vdc
1800	1378	4.9	1512	5.3	1649	5.8	1786	6.3	1918	6.8
1950	1473	5.2	1594	5.6	1721	6.1	1848	6.5	1973	7.0
2100	1569	5.5	1680	5.9	1796	6.3	1915	6.8	2032	7.2
2250	1666	5.9	1769	6.2	1876	6.6	1986	7.0	2096	7.4
2400	1764	6.2	1860	6.6	1959	6.9	2061	7.3	2165	7.6
2550	1863	6.6	1952	6.9	2045	7.2	2140	7.5	2237	7.9
2700	1962	6.9	2046	7.2	2133	7.5	2222	7.8	2313	8.2
2850	2062	7.3	2141	7.5	2223	7.8	2307	8.1	2392	8.4
3000	2163	7.6	2238	7.9	2315	8.2	2394	8.4	2474	8.7

CFM	AVAILABLE EXTERNAL STATIC PRESSURE (in. wg)									
	1.2		1.4		1.6		1.8		2.0	
	rpm	vdc	rpm	vdc	rpm	vdc	rpm	vdc	rpm	vdc
1800	2044	7.2	2163	7.6	2276	8.0	2383	8.4	2486	8.8
1950	2094	7.4	2210	7.8	2320	8.2	2426	8.6	2527	8.9
2100	2148	7.6	2259	8.0	2367	8.3	2471	8.7	2570	9.1
2250	2206	7.8	2313	8.2	2417	8.5	2518	8.9	2616	9.2
2400	2268	8.0	2370	8.4	2471	8.7	2568	9.1	2664	9.4
2550	2335	8.2	2432	8.6	2528	8.9	2622	9.2	2714	9.6
2700	2405	8.5	2497	8.8	2589	9.1	2679	9.4	2768	9.8
2850	2479	8.7	2566	9.0	2653	9.4	2740	9.7	2826	10.0
3000	2556	9.0	2639	9.3	2722	9.6	2804	9.9	—	—

High Static 1378-2836 rpm

## APPENDIX D – WIRING DIAGRAMS

### Wiring Diagrams

50FCQ*04-07 UNITS					
SIZE	VOLTAGE	CONTROL (OVERLAY)	PAGE	POWER	PAGE
<b>04-06 Electro-Mechanical W7212 Controller</b>	208/230-1-60	48TC003166	94	48TC003163	101
	208/230-3-60			48TC003162	102
	460/575-3-60			48TC003164	103
<b>04-06 Electro-Mechanical W7220 Controller</b>	208/230-1-60	48TC003166 (48TC003217)	95	48TC003163	101
	208/230-3-60			48TC003162	102
	460/575-3-60			48TC003164	103
<b>07 Electro-Mechanical W7220 Controller</b>	208/230-3-60	48TC003160	96	48TC003162	102
	460/575-3-60	48TC003161	97	48TC003164	103
<b>04-06 RTU Open Controller (Factory Option)</b>	208/230-1-60	48TC003166 (48TC003214)	98	48TC003163	101
	208/230-3-60			48TC003162	102
	460/575-3-60			48TC003164	103
<b>07 RTU Open Controller (Factory Option)</b>	208/230-3-60	48TC003160 (48TC003214)	99	48TC003162	102
	460/575-3-60	48TC003161 (48TC003214)	100	48TC003164	103
<b>04-06 SystemVu™ Controller (Factory Option)</b>	208/230-1-60	48TC003206	104	48TC003211	106
	208/230-3-60			48TC003212	107
	460/575-3-60			48TC003213	108
<b>07 SystemVu Controller (Factory Option)</b>	208/230-3-60	48TC003207	105	48TC003212	107
	460/575-3-60			48TC003213	108



# APPENDIX D – WIRING DIAGRAMS (cont)

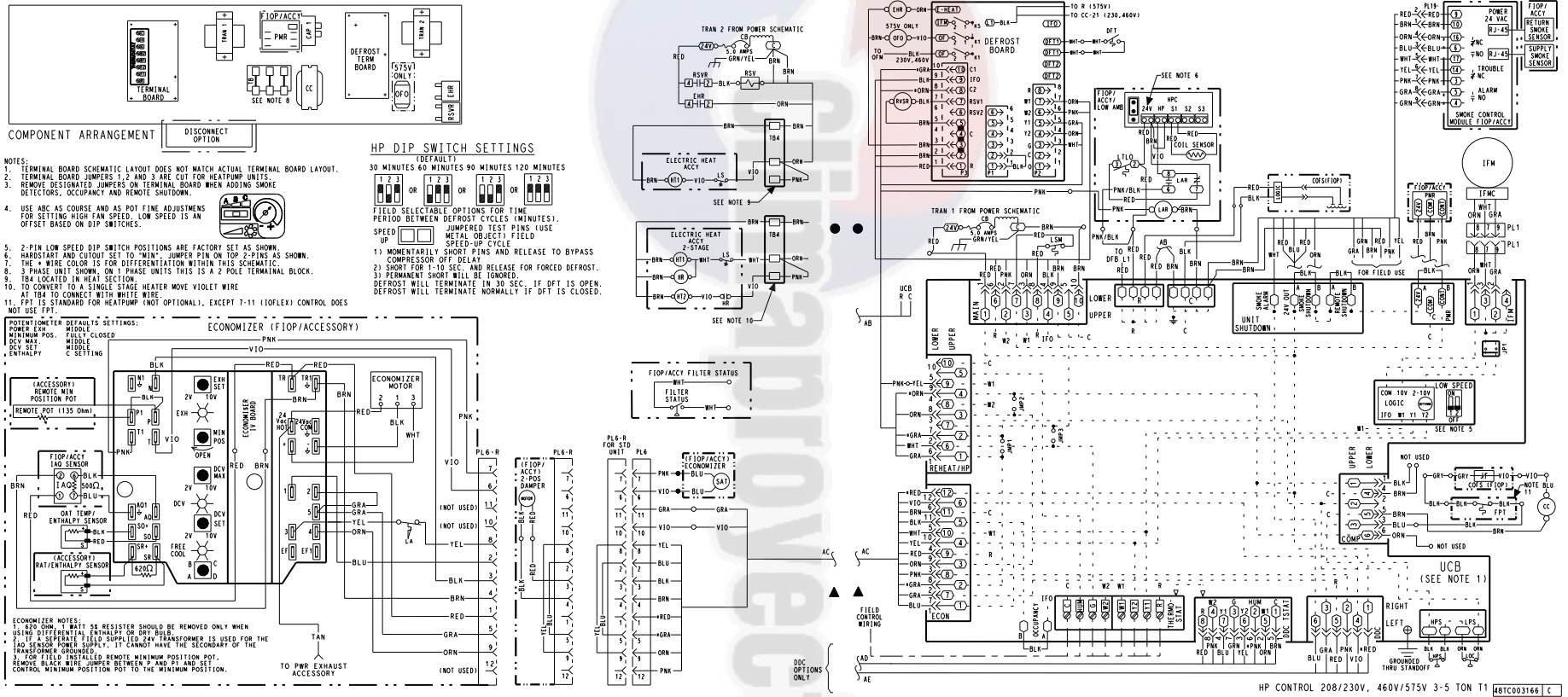


Fig. B – 50FCQ\*04-06 Electro-Mechanical Control Wiring Diagram – 208/230-3-60 (with W7212 Control)

# APPENDIX D – WIRING DIAGRAMS (cont)

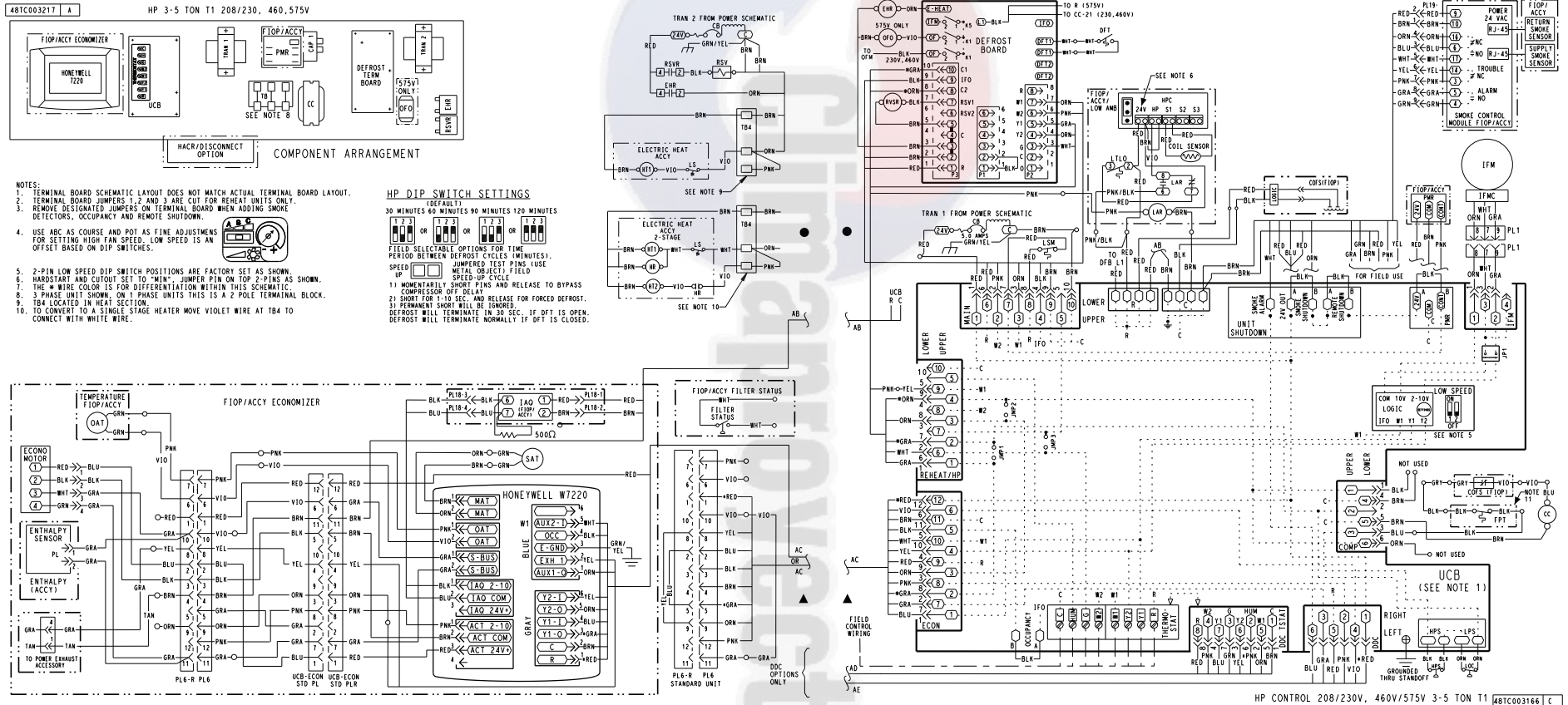
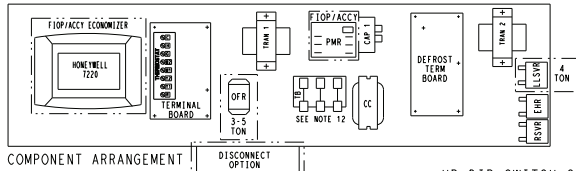


Fig. C – 50FCQ\*04-06 Electro-Mechanical Control Wiring Diagram – All Voltages (with W720 Control)



# APPENDIX D – WIRING DIAGRAMS (cont)



- NOTES**
1. TERMINAL BOARD SCHEMATIC LAYOUT DOES NOT MATCH ACTUAL TERMINAL BOARD LAYOUT.
  2. TERMINAL BOARD JUMPERS 1, 2 AND 3 ARE CUT FOR HEATPUMP UNITS.
  3. REMOVE DESIGNATED JUMPERS ON TERMINAL BOARD WHEN ADDING SMOKE DETECTORS, OCCUPANCY AND REMOTE SHUTDOWN.
  4. USE ABC AS COURSE AND AS POT FINE ADJUSTMENTS FOR SETTING HIGH FAN SPEED. LOW SPEED IS AN OFFSET BASED ON DIP SWITCHES.
  5. 2-PIN LOW SPEED DIP SWITCH POSITIONS ARE FACTORY SET AS SHOWN. HARDSTART AND CUTOFF SET TO "MIN". JUMPER PIN ON TOP 2-PINS AS SHOWN.
  6. THE "A" WIRE COLOR IS FOR DIFFERENTIATION WITHIN THIS SCHEMATIC.
  7. COMPRESSOR LEADER PLUG CONTAINS BRIDGE RECTIFIER TO CONVERT AC TO DC.
  8. TB4 LOCATED IN HEAT SECTION.
  9. TO CONVERT TO A SINGLE STAGE HEATER MOVE VIOLET WIRE
  10. AT TB4 TO CONNECT WITH WHITE WIRE
  11. ON 3 & 5 TON UNITS, PINK FROM MPC CONNECTS DIRECTLY TO YEL FROM PIN 13
  12. 3 PHASE TB SHOWN. COMPONENTS MAY VARY BASED ON EXACT PRODUCT & OPTIONS.
  13. FPT IS STANDARD FOR HEATPUMP (NOT OPTIONAL), EXCEPT 7-11 (F10P/ACT) CONTROL DOES NOT USE FPT.

### HP DIP SWITCH SETTINGS

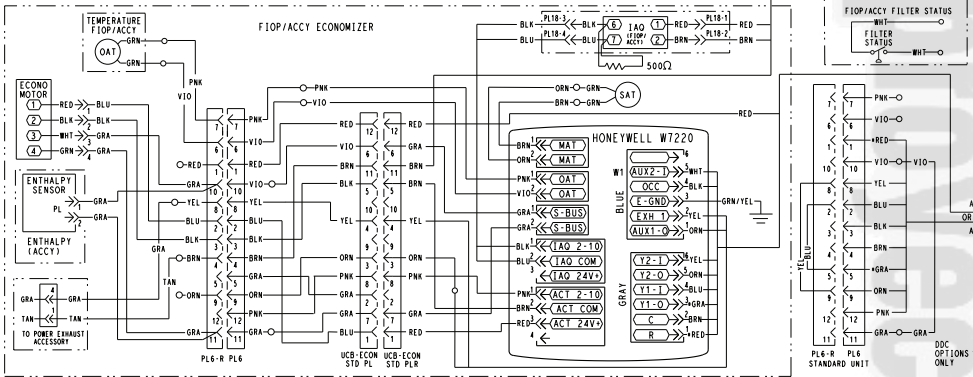
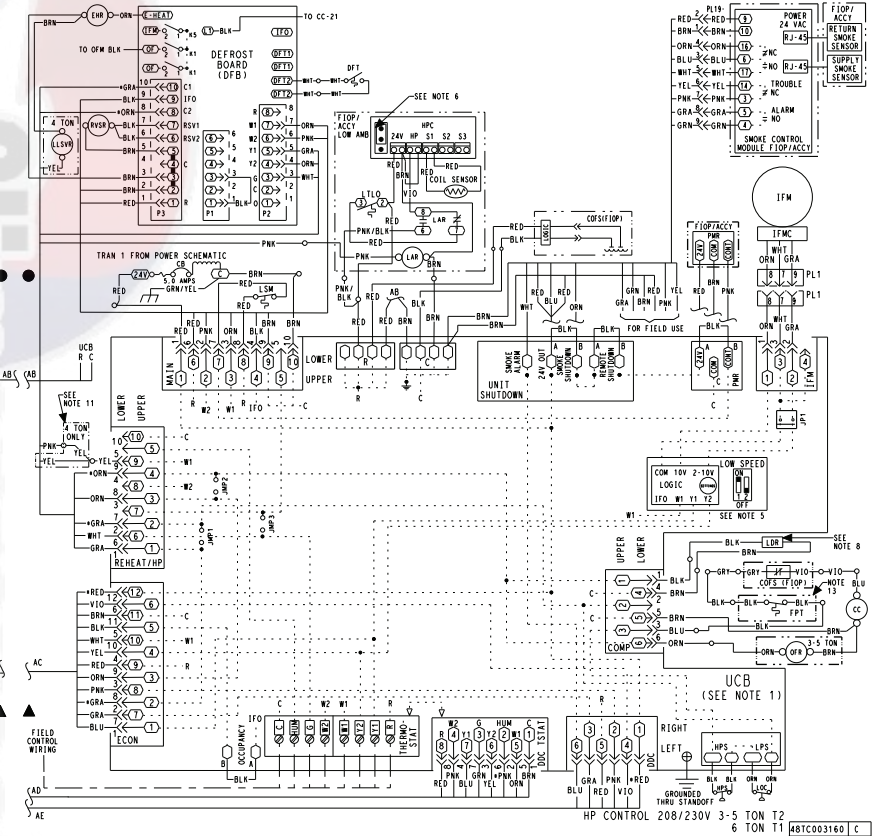
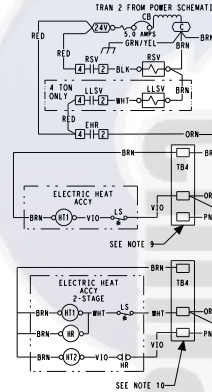
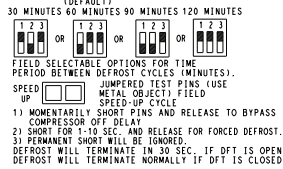
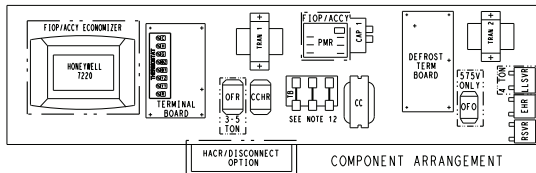


Fig. D – 50FCQ\*07 Electro-Mechanical Control Wiring Diagram – 208/230-3-60 (with W220 Control)

# APPENDIX D – WIRING DIAGRAMS (cont)



- NOTES:**
1. TERMINAL BOARD SCHEMATIC LAYOUT DOES NOT MATCH ACTUAL TERMINAL BOARD LAYOUT.
  2. TERMINAL BOARD JUMPERS 1, 2, AND 3 ARE CUT FOR REMEAT UNITS ONLY.
  3. REMOVE DESIGNATED JUMPERS ON TERMINAL BOARD WHEN ADDING SMOKE DETECTORS, OCCUPANCY AND REMOTE SHUTDOWN.
  4. USE ABC AS COURSE AND POT AS FINE ADJUSTMENTS FOR SETTING HIGH FAN SPEED. LOW SPEED IS AN OFFSET BASED ON DIP SWITCHES.
  5. 2-PIN LOW SPEED DIP SWITCH POSITIONS ARE FACTORY SET AS SHOWN. HARDSTART AND CUTOFF SET TO "MIN". JUMPER PIN ON TOP 2-PINS AS SHOWN.
  6. THE 4 WIRE COLOR IS FOR DIFFERENTIATION WITHIN THIS SCHEMATIC.
  7. COMPRESSOR LONGER PLUG CONTAINS BRIDGE RECTIFIER TO CONVERT AC TO DC.
  8. TB4 LOCATED IN HEAT SECTION.
  9. TO CONVERT TO A SINGLE STAGE HEATER MOVE VIOLET WIRE AT TB4 TO CONNECT WITH WHITE WIRE.
  10. ON 3 & 5 TON UNITS, PNK FROM HFC CONNECTS DIRECTLY TO YEL FROM PIN 13.
  11. COMPONENT MAY VARY BASED ON PRODUCT & OPTIONS.
  12. FRT IS STANDARD FOR HEATPUMP (NOT OPTIONAL), EXCEPT 7-11 (IOFLX) CONTROL DOES NOT USE FRT.

### HP DIP SWITCH SETTINGS

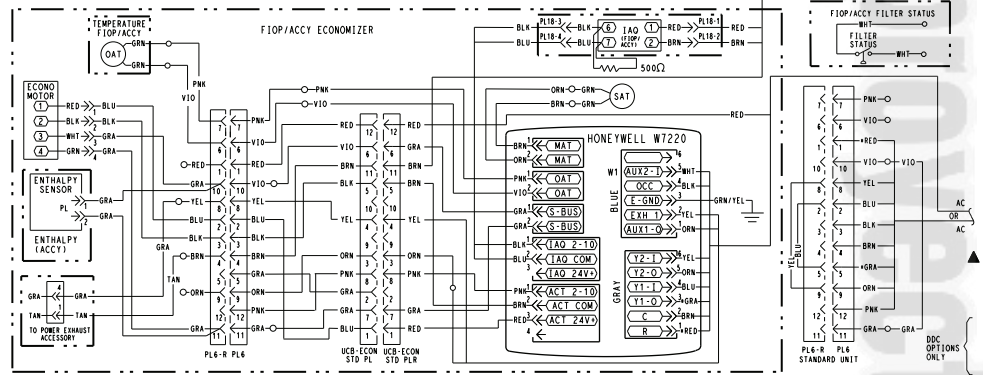
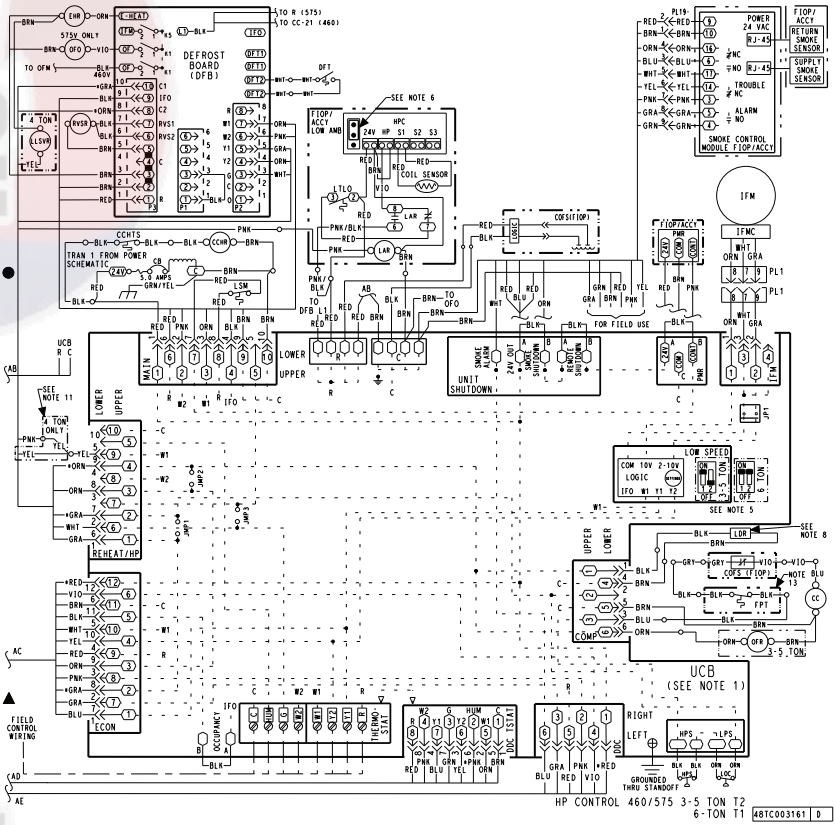
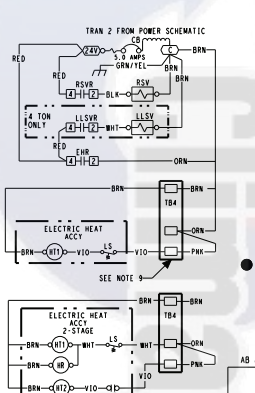
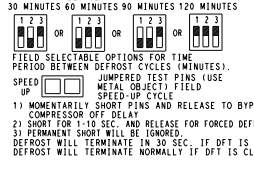
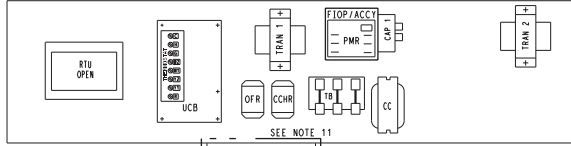


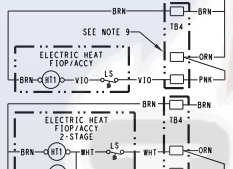
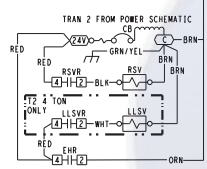
Fig. E – 50FCQ\*07 Electro-Mechanical Control Wiring Diagram – 460/575-3-60 (with W7220 Control)

# APPENDIX D – WIRING DIAGRAMS (cont)

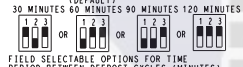
48TC003214 A HP 3-5 TON T2 & 3-6 TON T1 208/230,460,575V RTU OPEN



- NOTES:
1. TERMINAL BOARD SCHEMATIC LAYOUT DOES NOT MATCH ACTUAL TERMINAL BOARD LAYOUT.
  2. TERMINAL BOARD JUMPERS 1, 2 AND 3 ARE OUT FOR REHEAT UNITS ONLY.
  3. REMOVE DESIGNATED JUMPERS ON TERMINAL BOARD WHEN ADDING SMOKE DETECTORS, OCCUPANCY AND REMOTE SHUTDOWN.
  4. NOT USED ON RTU OPEN.
  5. USE RTU OPEN SETTING TO ADJUST FAN SPEED.
  6. HANDSTART AND CUTOFF SET TO "MIN" JUMPER PIN ON TOP 2-PINS AS SHOWN.
  7. THE \* WIRE COLOR IS FOR DIFFERENTIATION WITHIN THIS SCHEMATIC.
  8. COMPRESSOR LEADER PLUG CONTAINING BRIDGE RECTIFIER TO CONVERT AC TO DC.
  9. TBA LOCATED IN THE HEAT SECTION.
  10. TO CONVERT TO A SINGLE STAGE HEATER MOVE VIOLET WIRE AT TBA TO CONNECT WITH WHITE WIRE.
  11. COMPONENTS MAY VARY BASED ON EXACT PRODUCT AND OPTIONS.
  12. FOLLOW THIS WIRING FOR IFM CONNECTOR WITH RTU OPEN, IGNORE IFM WIRING AT UCB.

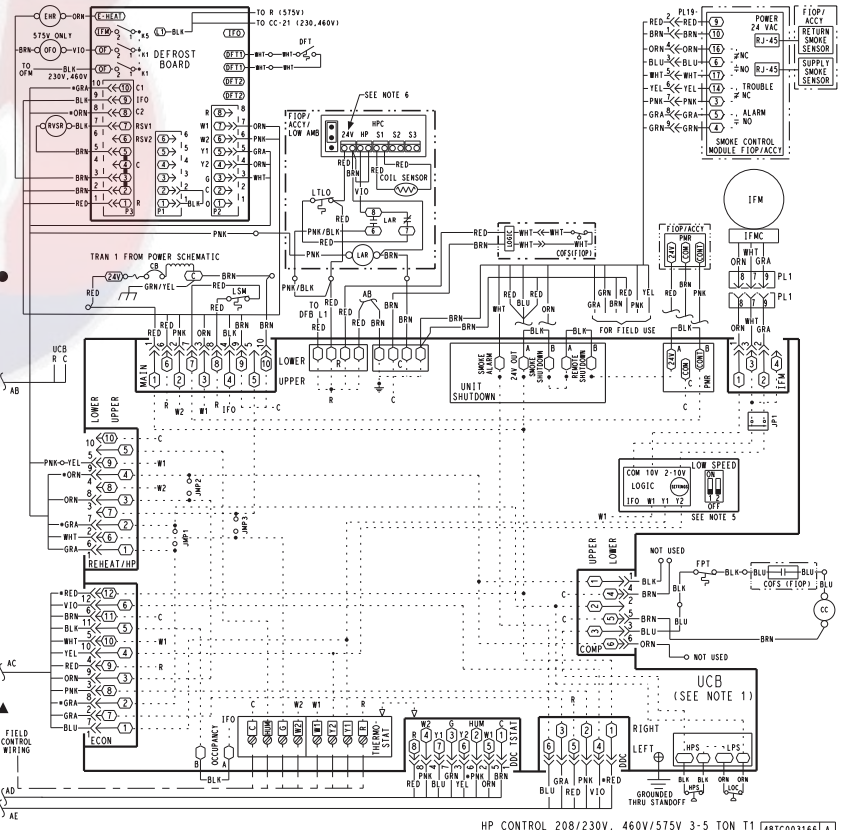
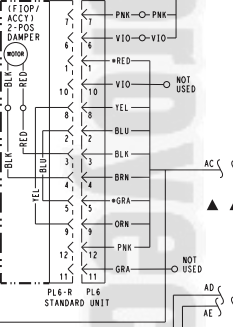
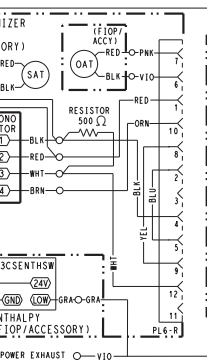
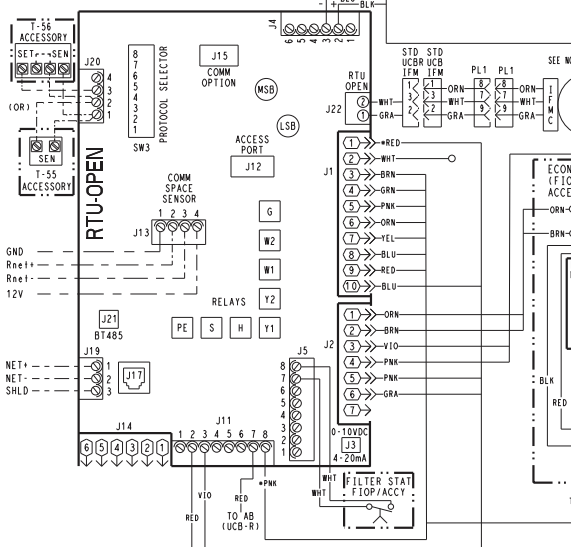


### HP DIP SWITCH SETTINGS



### FIELD SELECTABLE OPTIONS FOR TIME PERIOD BETWEEN DEFROST CYCLES (MINUTES).

- JUMPERED TEST PINS USE SPEED UP METAL OBJECT FIELD.
- 1) MOMENTARILY SHORT PINS AND RELEASE TO BYPASS COMPRESSOR OF DELAY.
  - 2) SHORT FOR 1-10 SEC. AND RELEASE FOR FORCED DEFROST.
  - 3) PERMANENT SHORT WILL BE IGNORED. DEFROST WILL TERMINATE IN 30 SEC. IF DFT IS OPEN. DEFROST WILL TERMINATE NORMALLY IF DFT IS CLOSED.



HP CONTROL 208/230V, 460V/575V 3-5 TON T1 48TC003166 A

Fig. F – 50FCQ\*04-06 Units, All Voltages – with Optional Factory-Installed RTU Open Controller

# APPENDIX D – WIRING DIAGRAMS (cont)

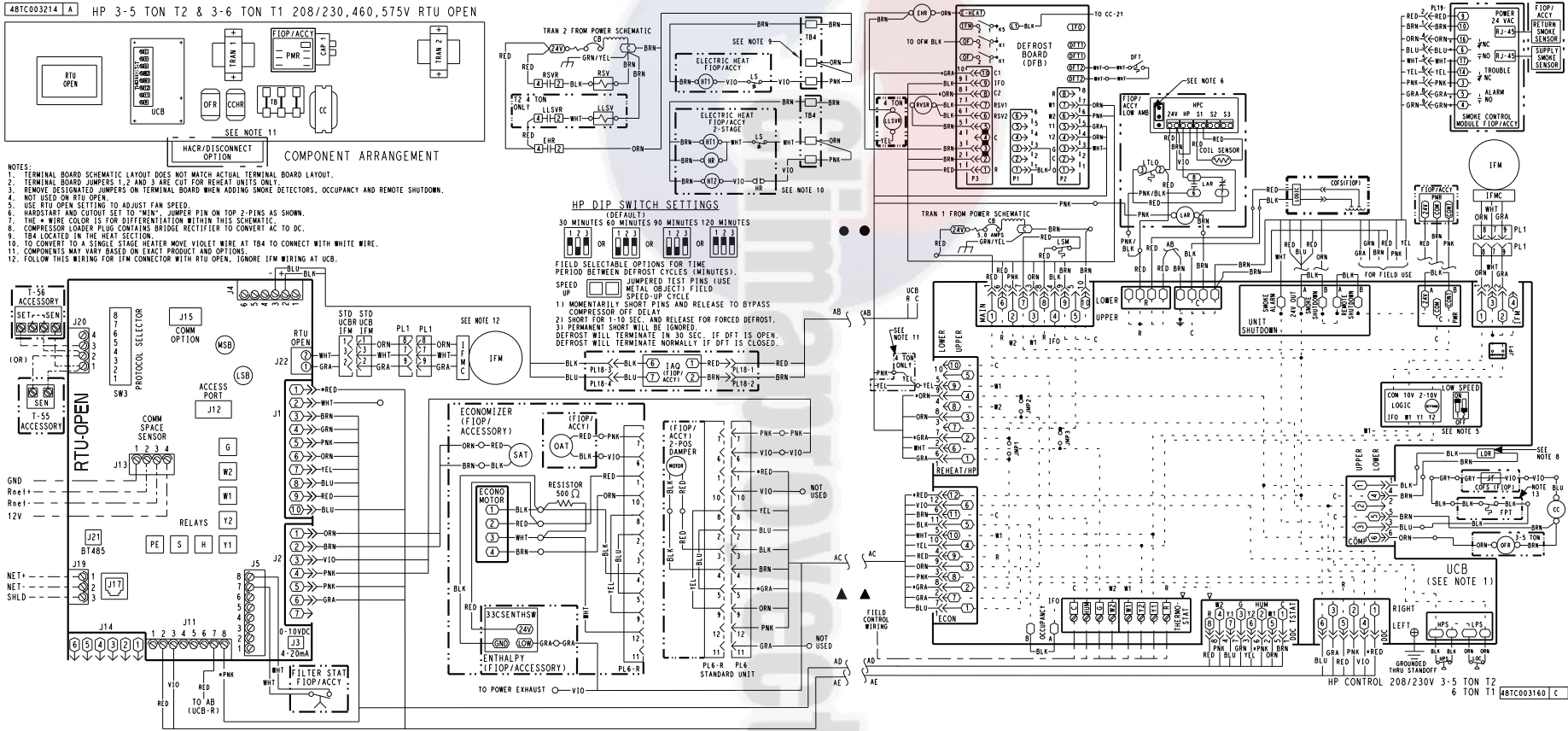


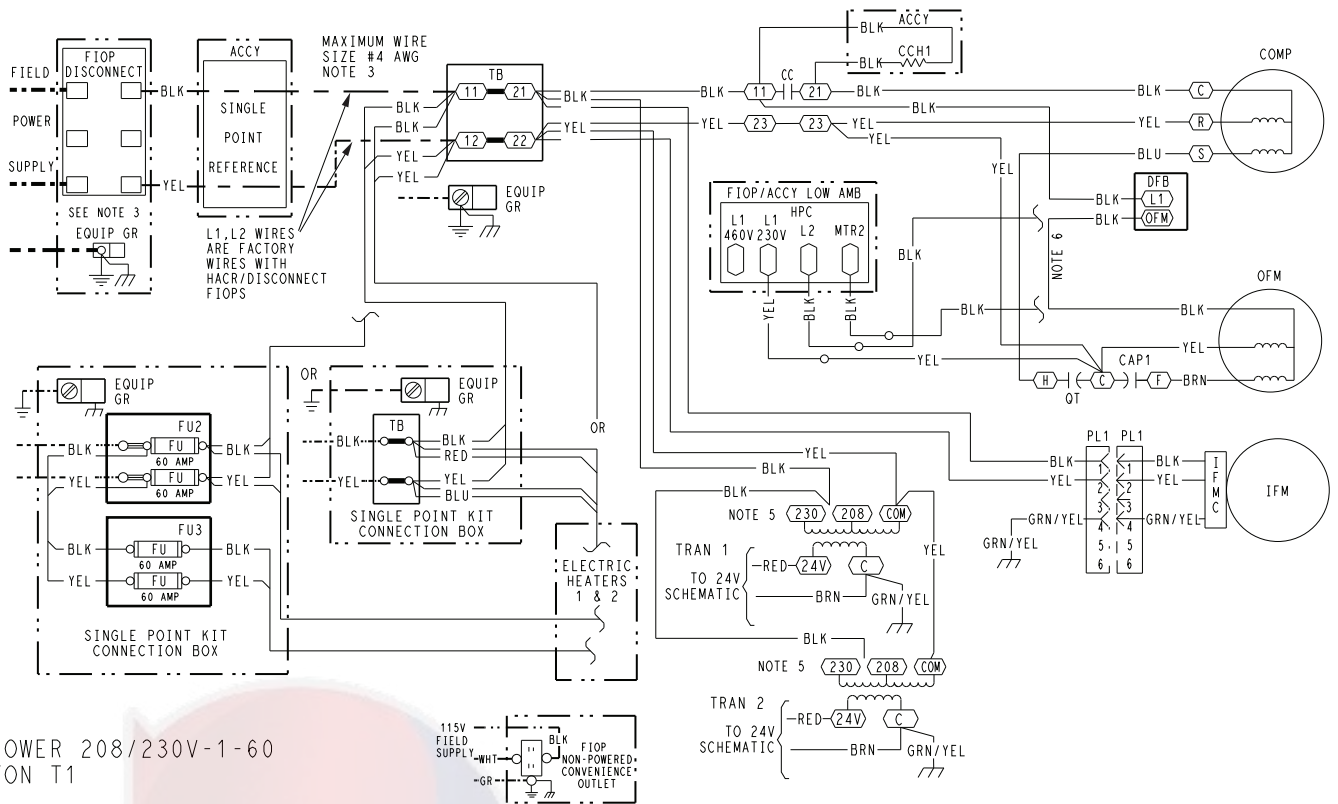
Fig. G – 50FCQ\*07 208/230-3-60 Units – with Optional Factory-Installed RTU Open Controller







## APPENDIX D — WIRING DIAGRAMS (cont)



HP POWER 208/230V-1-60  
3-5TON T1

**NOTES**

1. IF ANY OF THE ORIGINAL WIRE FURNISHED MUST BE REPLACED, IT MUST BE REPLACED WITH TYPE 90° C WIRE OR ITS EQUIVALENT.
2. COMPRESSOR AND FAN MOTORS ARE THERMALLY PROTECTED.
3. USE COPPER CONDUCTOR ONLY.
4. DO NOT DISCONNECT POWER PLUG OR SIGNAL WIRE WHILE UNDER LOAD.
5. ON 208/230V UNITS, TRAN IS WIRED FOR 230V. IF UNIT IS TO BE RUN WITH 208V POWER SUPPLY, DISCONNECT BLK WIRE FROM 230V TAP AND CONNECT TO 208V TAP.
6. THIS WIRE NOT USED WITH LOW AMBIENT FIOP/ACCY.

**LEGEND**

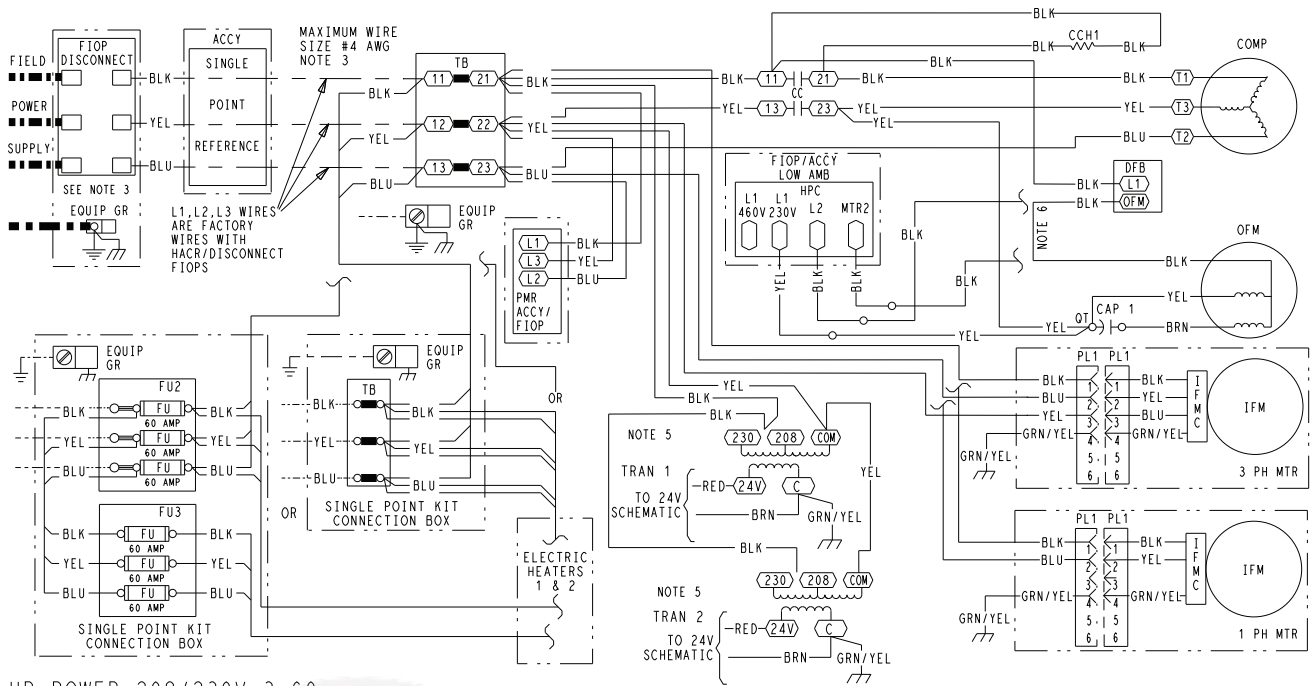
- X MARKED WIRE
- X TERMINAL (MARKED)
- TERMINAL (UNMARKED)
- X TERMINAL BLOCK
- SPLICE
- X SPLICE (MARKED)
- FACTORY WIRING
- - - FIELD CONTROL WIRING
- - - - - FIELD POWER WIRING
- - - - - CIRCUIT BOARD TRACE
- - - - - ACCESSORY OR OPTIONAL WIRING

ACCY	ACCESSORY	HR	HEATER RELAY	PER	POWER EXHAUST RELAY
AWG	AMERICAN WIRE GAGE	HGRH	HOT GAS REHEAT	PH	PHASE
BAS	BUILDING AUTOMATION NETWORK	HPC	HEAD PRESSURE CONTROL	PL	PLUG ASSEMBLY
CC	CONTACTOR, COMPRESSOR COMMON	HPS	HIGH PRESSURE SWITCH	POT	POTENTIOMETER
C	COMMON	HUM	HUMIDISTAT	PMR	PHASE MONITOR RELAY
CAP	CAPACITOR	IAQ	INDOOR AIR QUALITY SENSORS	PS	PRESSURE SWITCH
CB	CIRCUIT BREAKER	IFM	INDOOR FAN MOTOR	PWM	PULSE WIDTH MODULATION
CCH	CRANKCASE HEATER	IFMC	INDOOR FAN MOTOR CONTROL	QT	QUADRUPLE TERMINAL
CCHR	CRANKCASE HEATER RELAY	IFO	INDOOR FAN ON SIGNAL	R	THERMOSTAT POWER
CCHT S	CRANKCASE HEATER TEMP SWITCH	IRH	INDOOR RELATIVE HUMIDITY	RAT	RETURN AIR TEMP. SEN
CLO	COMPRESSOR LOCKOUT	JMP	JUMPER	RDV	REHEAT DISCHARGE VALVE
CLV	COOLING LIQUID VALVE	L	LINE 1	RH	RELATIVE HUMIDITY
COFS	CONDENSATE OVERFLOW SWITCH	LA	LOW AMBIENT LOCKOUT	RLV	REHEAT LIQUID VALVE
COM	SIGNAL COMMON	LAR	LOW AMBIENT RELAY	RNET	LOCAL ACCESS NETWORK
COMP	COMPRESSOR MOTOR	LAS	LOW AMBIENT SWITCH	RVS	REVERSING VALVE SOLENOID
DDC	DIRECT DIGITAL CONTROL	LDR	COMPRESSOR LOADER	SAT	SUPPLY AIR TEMP SENSOR
DFB	DEFROST BOARD	LEN	LOCAL EQUIPMENT NETWORK	SDP	SYSTEM DISCHARGE PRESSURE
DFT	DEFROST THERMOSTAT	LOC	LOSS OF CHARGE	SPRH	SPACE RELATIVE HUMIDITY
EHR	ELECTRIC HEAT RELAY	LPS	LOW PRESSURE SWITCH	SPT	SPACE TEMPERATURE SENSOR
ENTH	ENTHALPY	LS	LIMIT SWITCH	SPTO	SPACE TEMPERATURE OFFSET
ERV	ENERGY RECOVERY VENTILATOR	LSM	LIMIT SWITCH (MANUAL RESET)	SSP	SYSTEM SUCTION PRESSURE SWITCH
ESL	ENTHALPY SENSOR - LOW	LTL0	LOW TEMP LOCKOUT	SW	SWITCH
FB	FUSE BLOCK	MTR	MOTOR	TB	TERMINAL BLOCK
FIOP	FACTORY INSTALLED OPTION	OAO	OUTDOOR AIR QUALITY	TDR	TIME DELAY RELAY
FPT	FREEZE PROTECTION THERMOSTAT	OAT	OUTDOOR AIR TEMP. SEN	TRAN	TRANSFORMER
FST	FAN HOUSING TEMP SENSOR	OFM	OUTDOOR FAN MOTOR	UCB	UNIT CONTROL BOARD
FU	FUSE	OFMR	OUTDOOR FAN RELAY	W1	1st STAGE OF HEATING CALL
G	THERMOSTAT FAN CALL	OL	OVERLOAD	W2	2nd STAGE OF HEATING CALL
GR(GND)	GROUND			Y1	1st STAGE OF COOLING CALL
HACR	HEATING, AIR-CONDITIONING, REFRIGERATION BREAKER			Y2	2nd STAGE OF COOLING CALL

48TC003163 | A

**Fig. I — 50FCQ\*04-06 Power Wiring Diagram — 208/230-1-60**

## APPENDIX D – WIRING DIAGRAMS (cont)



HP POWER 208/230V-3-60  
3-6TON T1

- NOTES
- IF ANY OF THE ORIGINAL WIRE FURNISHED MUST BE REPLACED, IT MUST BE REPLACED WITH TYPE 90° C WIRE OR ITS EQUIVALENT.
  - COMPRESSOR AND FAN MOTORS ARE THERMALLY PROTECTED.
  - USE COPPER CONDUCTOR ONLY.
  - DO NOT DISCONNECT POWER PLUG OR SIGNAL WIRE WHILE UNDER LOAD.
  - ON 208/230V UNITS, TRAN IS WIRED FOR 230V. IF UNIT IS TO BE RUN WITH 208V POWER SUPPLY, DISCONNECT BLK WIRE FROM 230V TAP AND CONNECT TO 208V TAP.
  - THIS WIRE NOT USED WITH LOW AMBIENT FIOP/ACCY.

### LEGEND

- (X) MARKED WIRE
- (X) TERMINAL (MARKED)
- (O) TERMINAL (UNMARKED)
- (Y) TERMINAL BLOCK
- (•) SPLICE
- (•) SPLICE (MARKED)
- FACTORY WIRING
- FIELD CONTROL WIRING
- FIELD POWER WIRING
- - - CIRCUIT BOARD TRACE
- - - ACCESSORY OR OPTIONAL WIRING

- ACCY ACCESSORY
- AWG AMERICAN WIRE GAGE
- BAS BUILDING AUTOMATION NETWORK
- CC CONTACTOR, COMPRESSOR
- C COMMON
- CAP CAPACITOR
- CB CIRCUIT BREAKER
- CCH CRANKCASE HEATER
- CCHR CRANKCASE HEATER RELAY
- CCHTS CRANKCASE HEATER TEMP SWITCH
- CLO COMPRESSOR LOCKOUT
- CLV COOLING LIQUID VALVE
- COFS CONDENSATE OVERFLOW SWITCH
- COM SIGNAL COMMON
- COMP COMPRESSOR MOTOR
- DDC DIRECT DIGITAL CONTROL
- DFB DEFROST BOARD
- DFT DEFROST THERMOSTAT
- EHR ELECTRIC HEAT RELAY
- ENTH ENTHALPY
- ERV ENERGY RECOVERY VENTILATOR
- ESL ENTHALPY SENSOR - LOW
- FB FUSE BLOCK
- FIOP FACTORY INSTALLED OPTION
- FFT FRETZE PROTECTION THERMOSTAT
- FST FAN HOUSING TEMP SENSOR
- FU FUSE

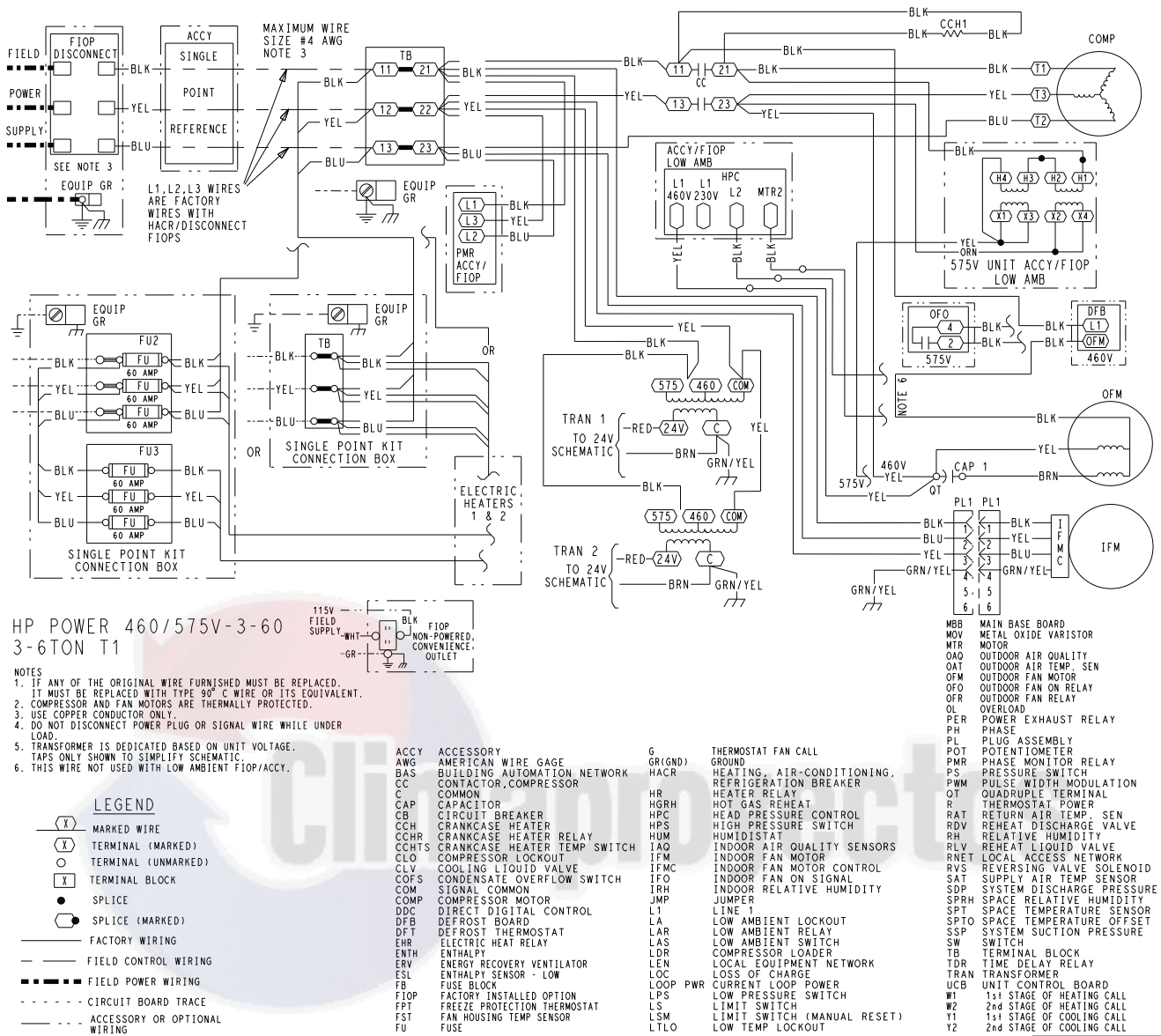
- G THERMOSTAT FAN CALL
- GR(ND) GROUND
- HACR HEATING, AIR-CONDITIONING, REFRIGERATION BREAKER
- HR HEATER RELAY
- HPC HEAD PRESSURE CONTROL
- HPS HIGH PRESSURE SWITCH
- IAQ INDOOR AIR QUALITY SENSORS
- IFM INDOOR FAN MOTOR
- IFMC INDOOR FAN MOTOR CONTROL
- IFO INDOOR FAN ON SIGNAL
- IRH INDOOR RELATIVE HUMIDITY
- JMP JUMPER
- L LINE 1
- LA LOW AMBIENT LOCKOUT
- LAR LOW AMBIENT RELAY
- LAS LOW AMBIENT SWITCH
- LPS LOW PRESSURE SWITCH
- LS LIMIT SWITCH
- LSM LIMIT SWITCH (MANUAL RESET)
- LTLO LOW TEMP LOCKOUT

- MTR MOTOR
- OAO OUTDOOR AIR QUALITY
- OAT OUTDOOR AIR TEMP. SEN
- OFM OUTDOOR FAN MOTOR
- OFR OUTDOOR FAN RELAY
- OL OVERLOAD
- PER POWER EXHAUST RELAY
- PH PHASE
- PL PLUG ASSEMBLY
- POT POTENTIOMETER
- PMR PHASE MONITOR RELAY
- PS PRESSURE SWITCH
- PWM PULSE WIDTH MODULATION
- OL QUADRUPLE TERMINAL
- R THERMOSTAT POWER
- RAT RETURN AIR TEMP. SENSOR
- RLV REHEAT LIQUID VALVE
- RNET LOCAL ACCESS NETWORK
- RVS REVERSING VALVE SOLENOID
- RVSR REVERSING VALVE RELAY
- SAT SUPPLY AIR TEMP SENSOR
- SDP SYSTEM DISCHARGE PRESSURE
- SPT SPACE TEMPERATURE SENSOR
- SPTO SPACE TEMPERATURE OFFSET
- SSP SYSTEM SUCTION PRESSURE
- SW SWITCH
- TB TERMINAL BLOCK
- TDR TIME DELAY RELAY
- TRAN TRANSFORMER
- UCB UNIT CONTROL BOARD
- W1 1st STAGE OF HEATING CALL
- W2 2nd STAGE OF HEATING CALL
- Y1 1st STAGE OF COOLING CALL
- Y2 2nd STAGE OF COOLING CALL

48TC003162 D

Fig. J — 50FCQ\*04-07 Power Wiring Diagram — 208/230-3-60

## APPENDIX D — WIRING DIAGRAMS (cont)



**Fig. K — 50FCQ\*04-07 Power Wiring Diagram — 460/575-3-60**

# APPENDIX D – WIRING DIAGRAMS (cont)

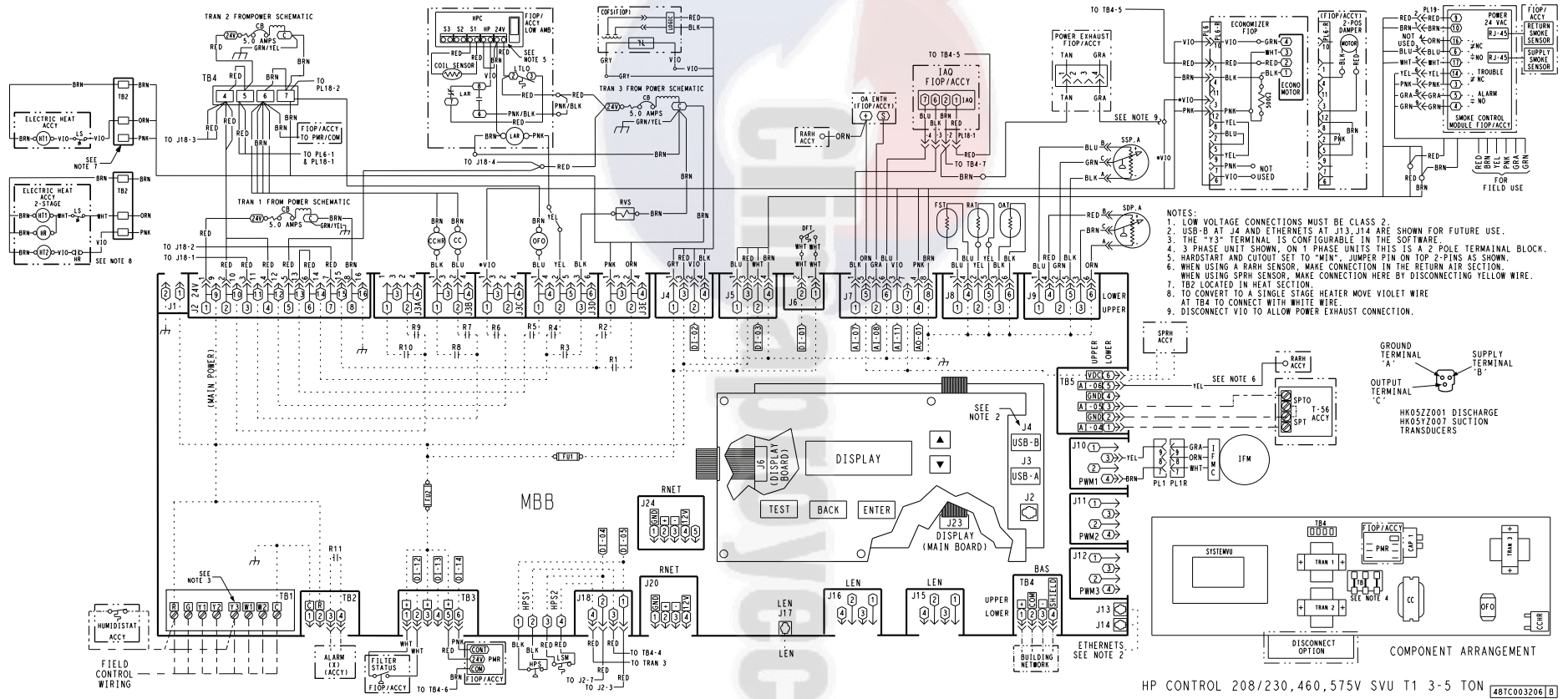


Fig. L – 50FCQ\*04-06 Units, All Voltages – Optional Factory-Installed SystemVu™ Controller

# APPENDIX D – WIRING DIAGRAMS (cont)

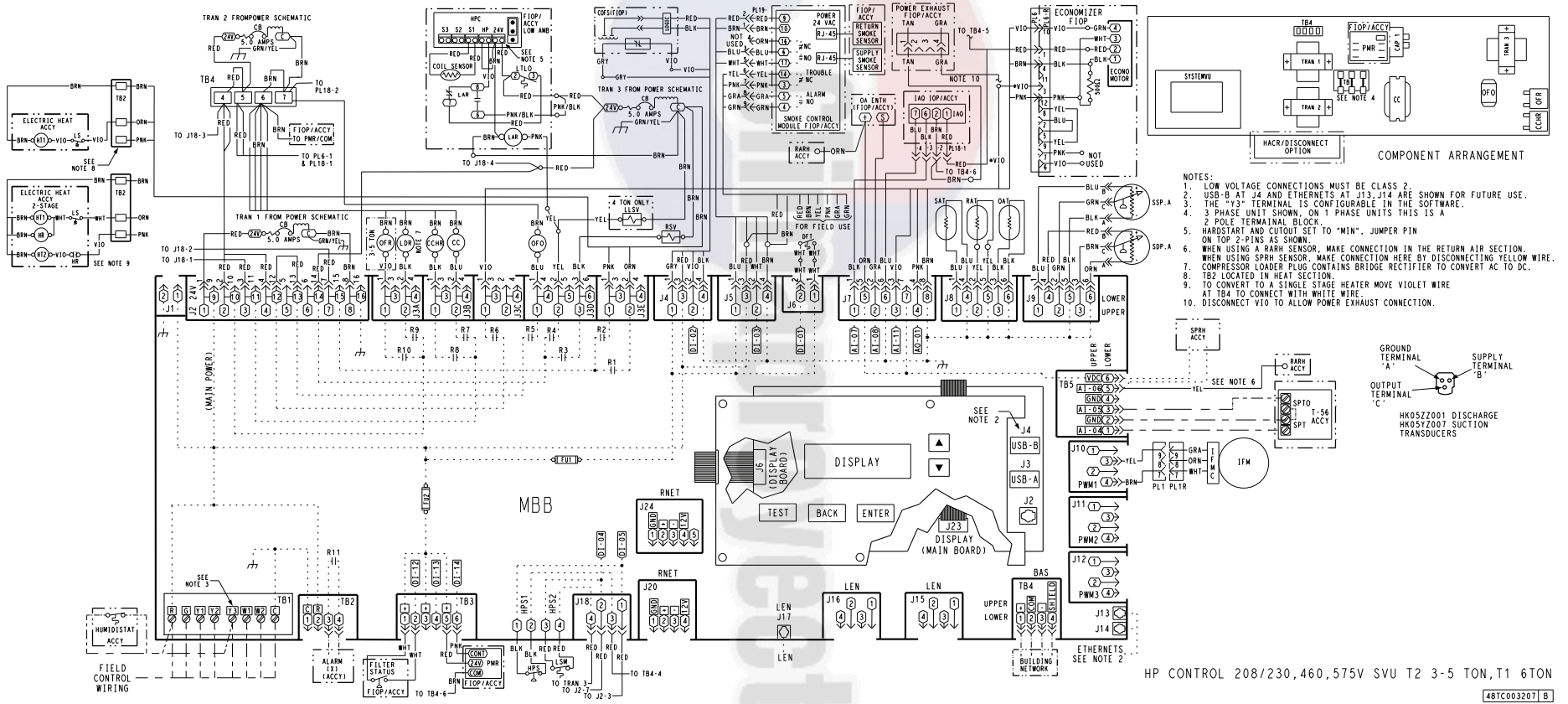
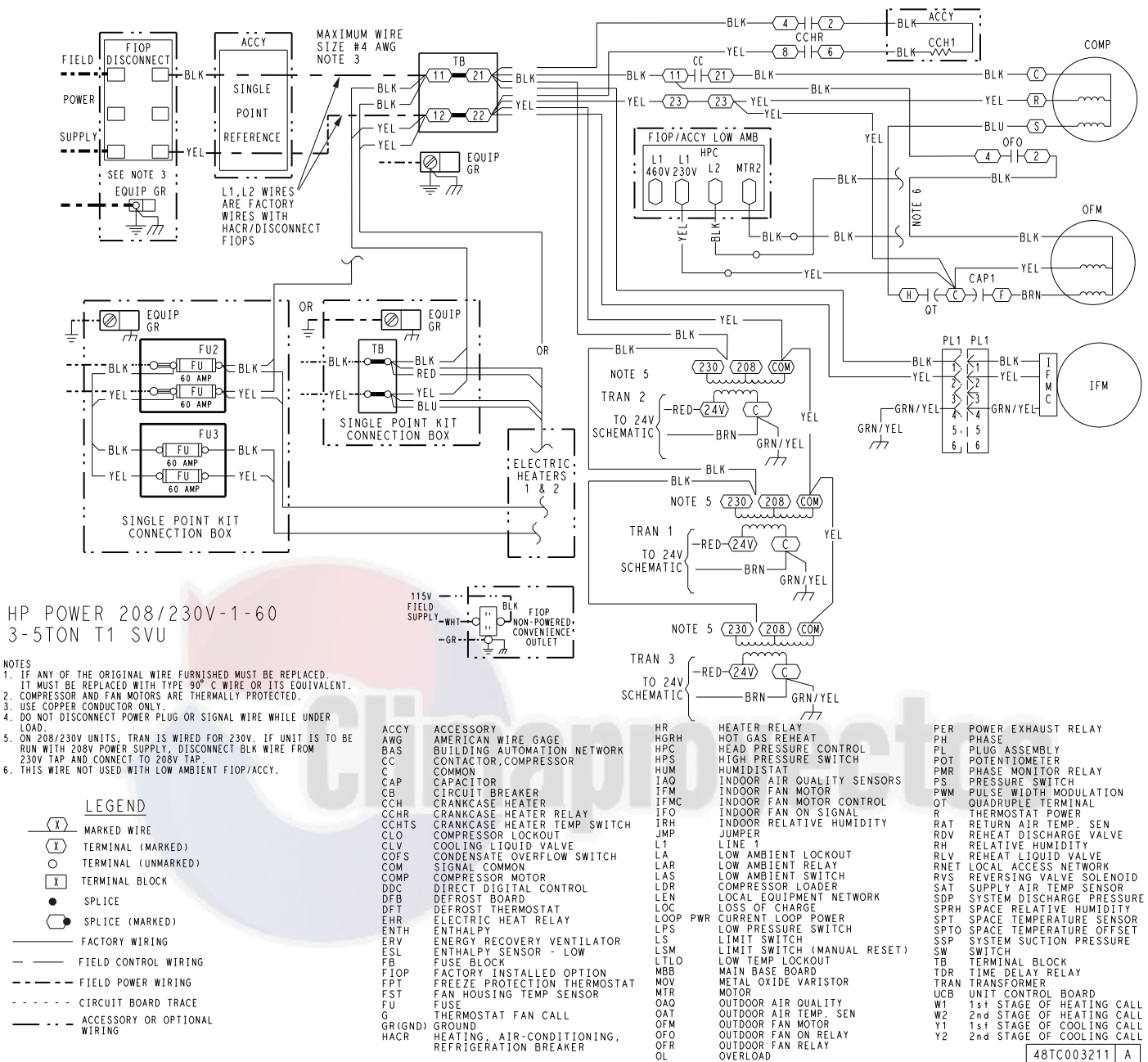


Fig. M – 50FCQ\*07 Units, All Voltages – Optional Factory-Installed SystemVu™ Controller



## APPENDIX D – WIRING DIAGRAMS (cont)

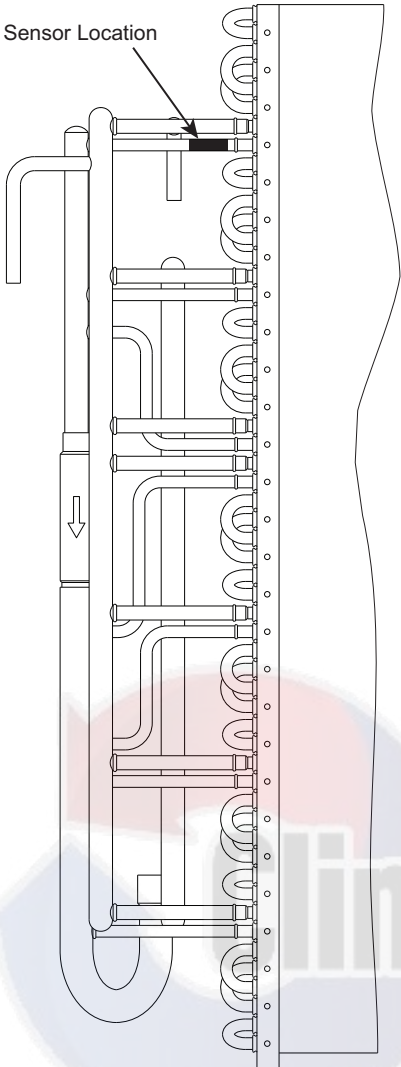


**Fig. N – 50FCQ\*04-06 SystemVu™ Power Wiring Diagram – 208/230-1-60**

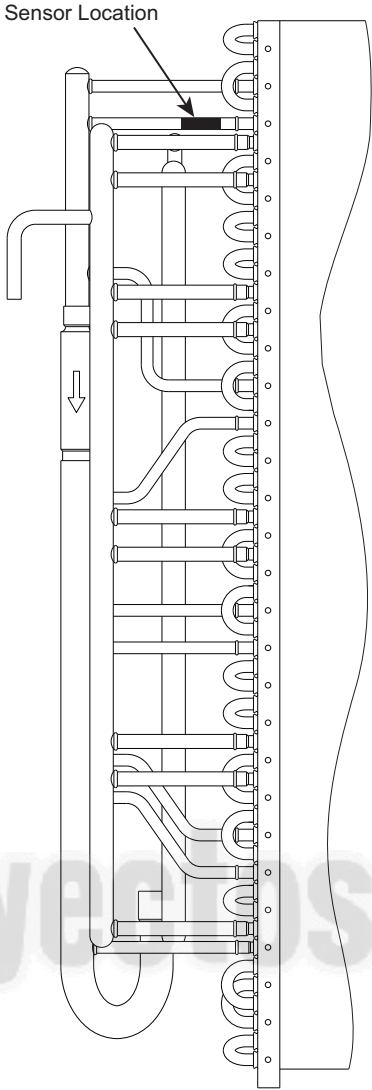




**APPENDIX E – LOW AMBIENT CONTROL SENSOR LOCATION**



**Fig. Q – 50FCQ\*04 Outdoor Circuiting**



**Fig. R – 50FCQ\*05 Outdoor Circuiting**

## APPENDIX E – LOW AMBIENT CONTROL SENSOR LOCATION (cont)

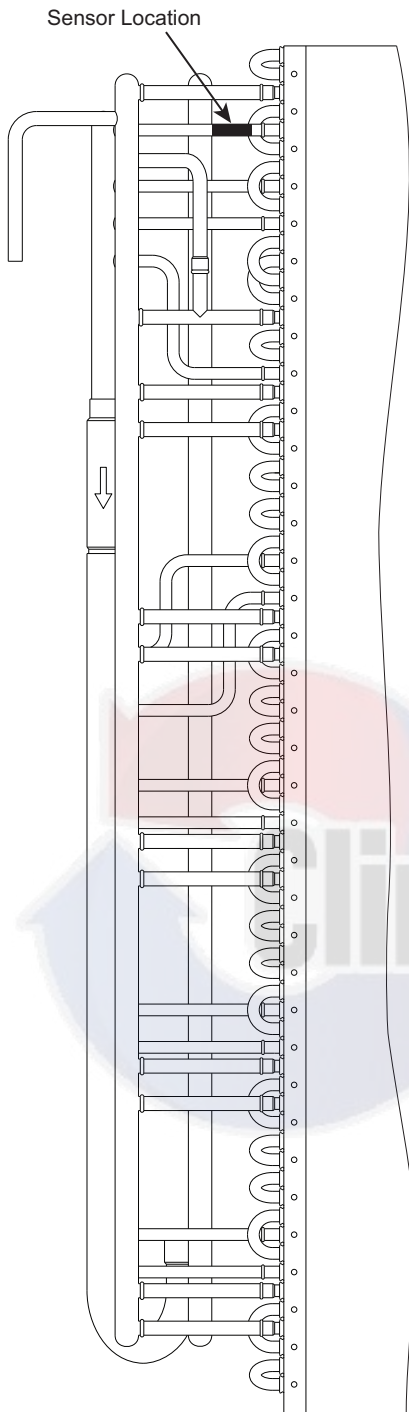


Fig. S – 50FCQ\*06 Outdoor Circuiting

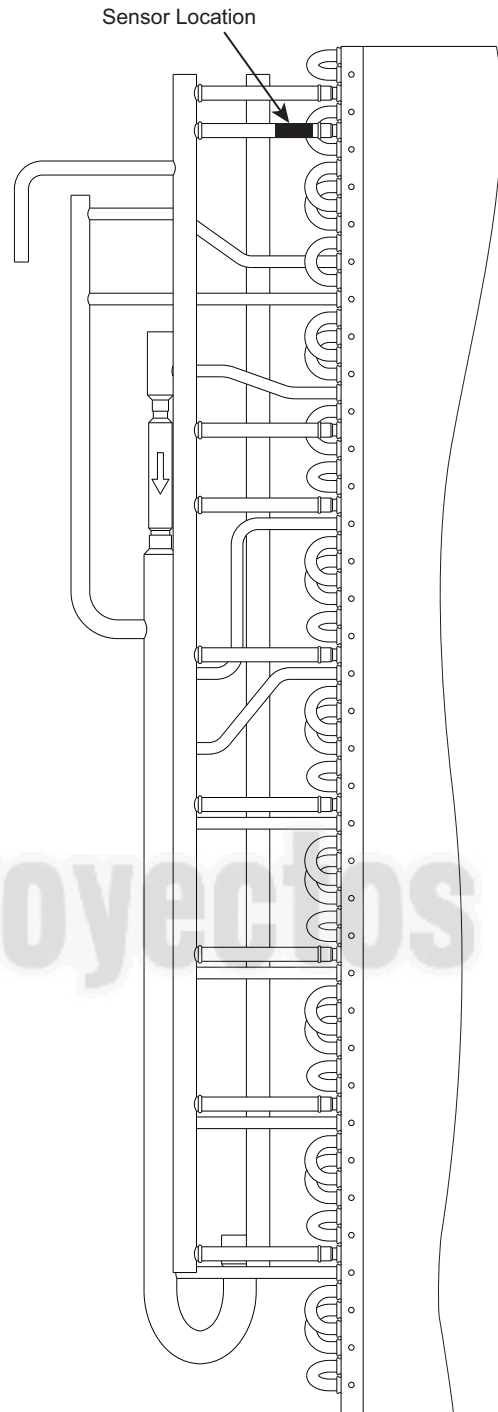


Fig. T – 50FCQ\*07 Outdoor Circuiting



# START-UP CHECKLIST FOR 50FCQ\*04-07 SINGLE PACKAGE ROOFTOP HEAT PUMP UNITS

(Remove and use for job file)

**NOTE: To avoid injury to personnel and damage to equipment or property when completing the procedures listed in this start-up checklist, use good judgment, follow safe practices, and adhere to the safety considerations/information as outlined in preceding sections of this Service and Maintenance document.**

## I. PRELIMINARY INFORMATION

MODEL NO. \_\_\_\_\_  
JOB NAME \_\_\_\_\_  
SERIAL NO. \_\_\_\_\_  
ADDRESS \_\_\_\_\_  
START-UP DATE \_\_\_\_\_  
TECHNICIAN NAME \_\_\_\_\_  
ADDITIONAL ACCESSORIES \_\_\_\_\_

## II. PRE-START-UP

Verify that all packaging materials have been removed from unit. (Y/N) \_\_\_\_\_  
Verify installation of outdoor air hood. (Y/N) \_\_\_\_\_  
Verify that condensate connection is installed per instructions. (Y/N) \_\_\_\_\_  
Verify that all electrical connections and terminals are tight. (Y/N) \_\_\_\_\_  
Verify ground integrity with a continuity test. (Y/N) \_\_\_\_\_  
Check that indoor-air filters are clean and in place. (Y/N) \_\_\_\_\_  
Check that outdoor air inlet screens are in place. (Y/N) \_\_\_\_\_  
Verify that unit is level. (Y/N) \_\_\_\_\_  
Verify that fan assembly is free of obstructions and rotor spins freely. (Y/N) \_\_\_\_\_  
Verify that scroll compressors are rotating in the correct direction. (Y/N) \_\_\_\_\_  
Verify installation of thermostat. (Y/N) \_\_\_\_\_

## III. START-UP

### ELECTRICAL

Supply Voltage	L1-L2 _____	L2-L3 _____	L3-L1 _____
Compressor Amps 1	L1 _____	L2 _____	L3 _____
Compressor Amps 2	L1 _____	L2 _____	L3 _____
Supply Fan Amps	L1 _____	L2 _____	L3 _____
Outdoor Fan Amps	L1 _____	L2 _____	

### TEMPERATURES

Outdoor-Air Temperature \_\_\_\_\_ °F DB (Dry Bulb)  
Return-Air Temperature \_\_\_\_\_ °F DB \_\_\_\_\_ °F WB (Wet Bulb)  
Cooling Supply Air Temperature \_\_\_\_\_ °F

Manufacturer reserves the right to discontinue, or change at any time, specifications or designs without notice and without incurring obligations.

**PRESSURES**

Refrigerant Suction \_\_\_\_\_ PSIG  
Refrigerant Discharge \_\_\_\_\_ PSIG  
Verify Refrigerant Charge using Charging Charts. (Y/N) \_\_\_\_\_

**GENERAL**

Economizer minimum vent and changeover settings to job requirements (if equipped). (Y/N) \_\_\_\_\_  
Verify smoke detector unit shutdown by utilizing magnet test. (Y/N) \_\_\_\_\_



CUT ALONG DOTTED LINE

CUT ALONG DOTTED LINE