

INSTALLATION INSTRUCTIONS

PACKAGE HEAT PUMP & AIR CONDITIONER

FEATURING R-410A

13 SEER SERIES - (2-5Tons)

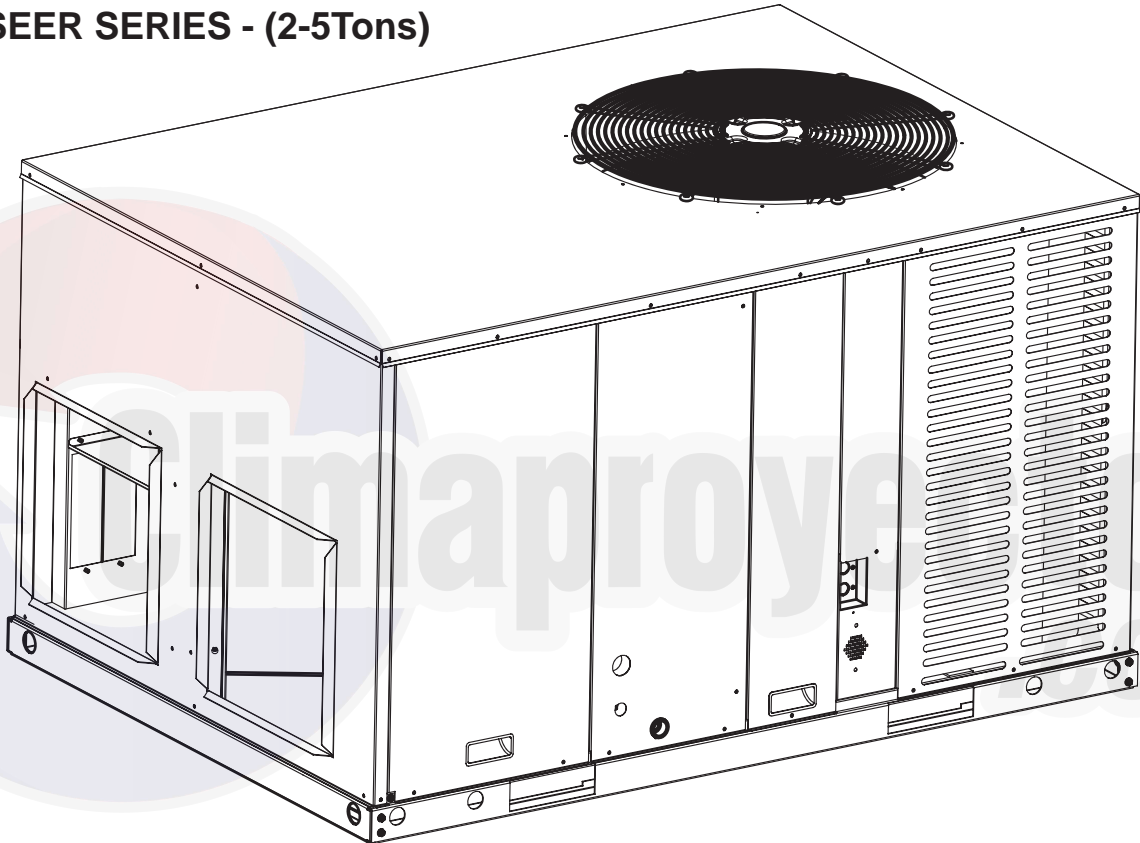

RECOGNIZE THIS SYMBOL AS AN INDICATION OF IMPORTANT SAFETY INFORMATION

WARNING

These instructions are intended as an aid to qualified, licensed service personnel for proper installation, adjustment and operation of this unit. Read these instructions thoroughly before attempting installation or operation. Failure to follow these instructions may result in improper installation, adjustment, service or maintenance possibly resulting in fire, electrical shock, property damage, personal injury or death.



DO NOT DESTROY THIS MANUAL

Please read carefully and keep in a safe place for future reference by a serviceman.

TABLE OF CONTENTS

1.0 SAFETY.....	3
1.1 INSPECTION.....	4
1.2 LIMITATIONS.....	4
2.0 INSTALLATION.....	4
2.1 PRE-INSTALLATION.....	4
2.2 CLEARANCE.....	5
2.3 RIGGING AND HANDING.....	5
3.0 DUCTWORK.....	8
4.0 CONDENSATE DRAIN CONNECTION.....	8
4.1 INSTALL DRAIN PIPE.....	8
5.0 FILTERS.....	9
6.0 ELECTRICAL WIRING.....	9
6.1 POWER WIRING.....	9
6.2 GROUNDING.....	10
6.3 CONTROL WIRING.....	10
7.0 AIRFLOW PERFORMANCE.....	14
7.1 AIRFLOW PERFORMANCE DATA.....	14
8.0 SYSTEM OPERATION.....	20
8.1 COMPRESSOR CRANKCASE HEATER.....	20
8.2 OPERATION.....	20
8.3 DEFROST MODE.....	21
8.4 MANUAL DEFROST MODE.....	21
8.5 THERMOSTAT SIGNALS.....	21
9.0 OPERATION CHECK-UP.....	23
10.0 TROUBLE SHOOTING.....	23

LIST OF TABLES

TABLE 2-1 UNIT CLEARANCE.....	7
TABLE 6-1 13 SEER HEAT PUMP W/WITHOUT ELECTRIC HEAT.....	12
TABLE 6-2 13 SEER COOLING ONLY W/WITHOUT ELECTRIC HEAT.....	12
TABLE 6-3 13 SEER PHYSICAL DATA.....	13
TABLE 7-1 DUCT APPLICATION(208V).....	14
TABLE 7-2 DUCT APPLICATION(230V).....	15
TABLE 7-3 REFRIGERANT CHARGE FOR A/C SYSTEM.....	16
TABLE 7-4 & 7-5 REFRIGERANT CHARGE FOR H/P SYSTEM.....	16
TABLE 7-6 REFRIGERANT CHARGE FOR A/C SYSTEM.....	17
TABLE 7-7 & 7-8 REFRIGERANT CHARGE FOR H/P SYSTEM.....	17
TABLE 7-9 REFRIGERANT CHARGE FOR A/C SYSTEM.....	18
TABLE 7-10 & 7-11 REFRIGERANT CHARGE FOR H/P SYSTEM.....	18
TABLE 7-12 REFRIGERANT CHARGE FOR A/C SYSTEM.....	19
TABLE 7-13 & 7-14 REFRIGERANT CHARGE FOR H/P SYSTEM.....	19
TABLE 8-1 THERMOSTAT SIGNALS.....	22

LIST OF FIGURES

FIG. 2-1 COMPONENT LOCATION.....	5
FIG. 2-2 UNIT DIMENSIONS.....	6
FIG. 2-3 UNIT DIMENSIONS.....	7
FIG. 6-1 TYPICAL FIELD CONTROL WIRING DIAGRAM.....	11
FIG. 6-2 TYPICAL FIELD POWER WIRING DIAGRAM.....	11
AC SYSTEM WIRING DIAGRAM (GMCC & LG COMPRESSOR).....	25
HP SYSTEM WIRING DIAGRAM (GMCC & LG COMPRESSOR).....	26

This document is customer property and is to remain with this unit. These instructions do not cover all the different variations of systems nor does it provide for every possible contingency to be met in connection with installation. All phases of this installation must comply with NATIONAL, STATE and LOCAL CODES. If additional information is required please contact your local distributor.

1.0 SAFETY

When you see the symbols below on the labels or in the manuals, be alert to the potential or immediate hazards of personal injury, property and/or product damage. It is the owner's or installer's responsibility to comply with all safety instructions and information accompanying these symbols.

 **WARNING:** This is a safety alert symbol indicating a potential hazardous situation, which could result in personal injury, property and/or product damage or death.

 **CAUTION:** This is a safety alert symbol indicating a potential hazardous situation, which could result in moderate personal injury, property and/or product damage.



WARNING

These instructions are intended as an aid to qualified, licensed service personnel for proper installation, adjustment and operation of this unit. Read these instructions thoroughly before attempting installation or operation. Failure to follow these instructions may result in improper installation, adjustment, service or maintenance possibly resulting in fire, electrical shock, property damage, personal injury or death.



WARNING

The manufacturer's warranty does not cover any damage or defect to the heat pump caused by the attachment or use of any components, accessories or devices (other than those authorized by the manufacturer) into, onto or in conjunction with the heat pump. You should be aware that the use of unauthorized components, accessories or devices may adversely affect the operation of the heat pump and may also endanger life and property. The manufacturer disclaims any responsibility for such loss or injury resulting from the use of such unauthorized components, accessories or devices.



WARNING

Disconnect all power to the unit before starting maintenance. Failure to do so can result in severe electrical shock or death.



WARNING

Do not, under any circumstances, connect return ductwork to any other heat producing device such as a fireplace insert, stove, etc. Unauthorized use of such devices may result in fire, carbon monoxide poisoning, explosion, property damage, severe personal injury or death.



WARNING

The unit must be permanently grounded. A grounding lug is provided. Failure to ground this unit can result in fire or electrical shock causing property damage, severe personal injury or death.



WARNING

Only electric heater kits supplied by this manufacturer as described in this publication have been designed, tested, and evaluated by a nationally recognized safety testing agency for use with this unit. Use of any other manufactured electric heaters installed within this unit may cause hazardous conditions resulting in property damage, fire, body injury or death.



WARNING

Proposition 65: This appliance contains fiberglass insulation. Respirable particles of fiberglass are known to the state of California to cause cancer.

1.1 INSPECTION

As soon as unit is received, it should be inspected and noted for possible shipping damage during transportation. It is carrier's responsibility to cover the cost of shipping damage. Manufacturer or distributor will not accept the claims from dealer for any transportation damage.

1.2 LIMITATIONS

Refer to *Fig. 2-2, 2-3* for unit physical data and to *Table 6-1 & 6-2* for electrical data. If components are to be added to a unit they must meet local codes, they are to be installed at the dealer's and /or the customer's expense.

Size of unit for proposed installation should be based on heat loss / heat gain calculations made in accordance with industry recognized procedures identified by the Air conditioning contractors of America.

2.0 INSTALLATION

2.1 PRE-INSTALLATION

Before installation, carefully check the following:

1. Unit should be installed in accordance with national and local safety codes, including but not limit to ANSI/NFPA No. 70 or Canadian Electrical Code Part 1, C22.1, local plumbing and wastewater codes and any other applicable codes.
2. For rooftop installation, be sure the structure has enough strength to support the weight of unit. Unit should be installed on roof curb and leveled.
3. For ground level installation, a level slab should be used.
4. Condenser airflow should not be restricted.
5. On applications when a roof curb is used, the unit must be positioned on the curb so the front of the unit is tight against the curb.

2.2 CLEARANCE

All units require certain clearance for proper operation and service. Refer to *Table 2-1* for the clearances required for construction, servicing and proper unit operation.

2.3 RIGGING AND HANDING

Exercise care when moving the unit. Do not remove any packaging until the unit is near the place of installation. Rig the unit by attaching chain or cable slings to the lifting holes provided in the base rails. Spreader bars, whose length exceeds the largest dimension across the unit, **MUST** be used across the top of the unit.



CAUTION

Before lifting, make sure the unit weight is distributed equally on the rigging cables so it will lift evenly.

Units may be moved or lifted with a forklift. Slotted openings in the base rails are provided for this purpose.



CAUTION

All panels must be secured in place when the unit is lifted. The condenser coils should be protected from rigging cable damage with plywood or other suitable material.

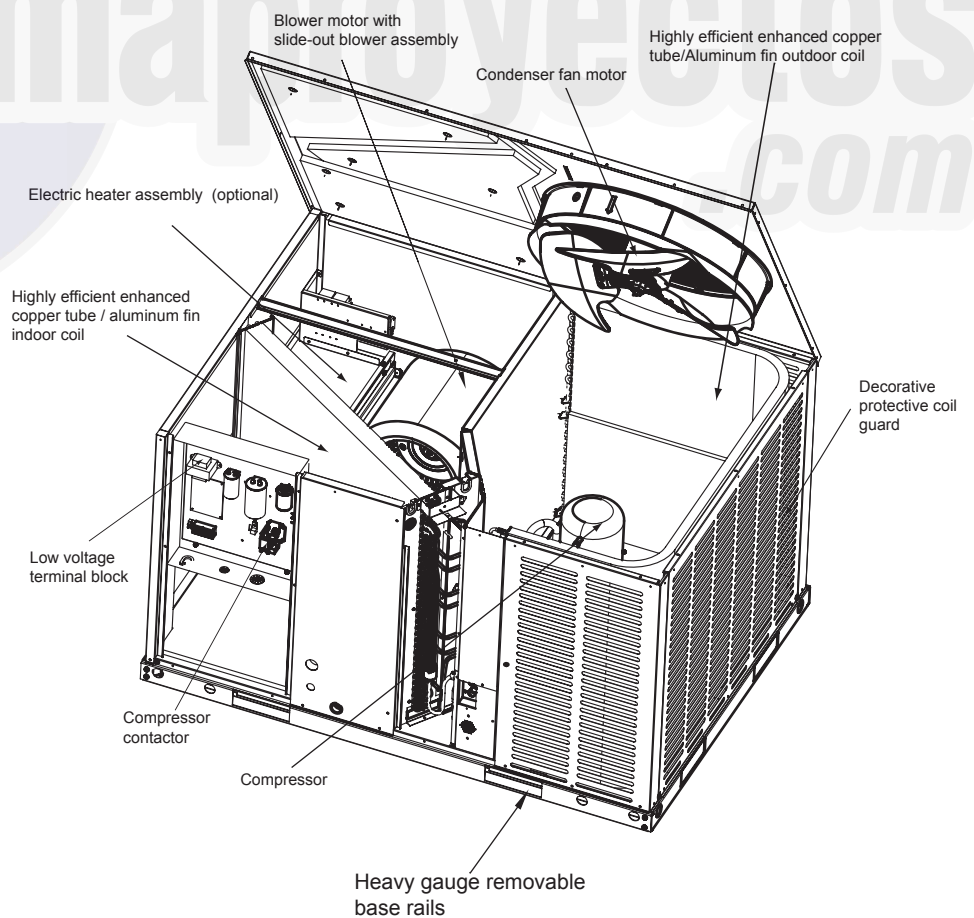

Fig. 2-1 Component Location

* The above figure for reference purpose only.

Unit size: 024, 036

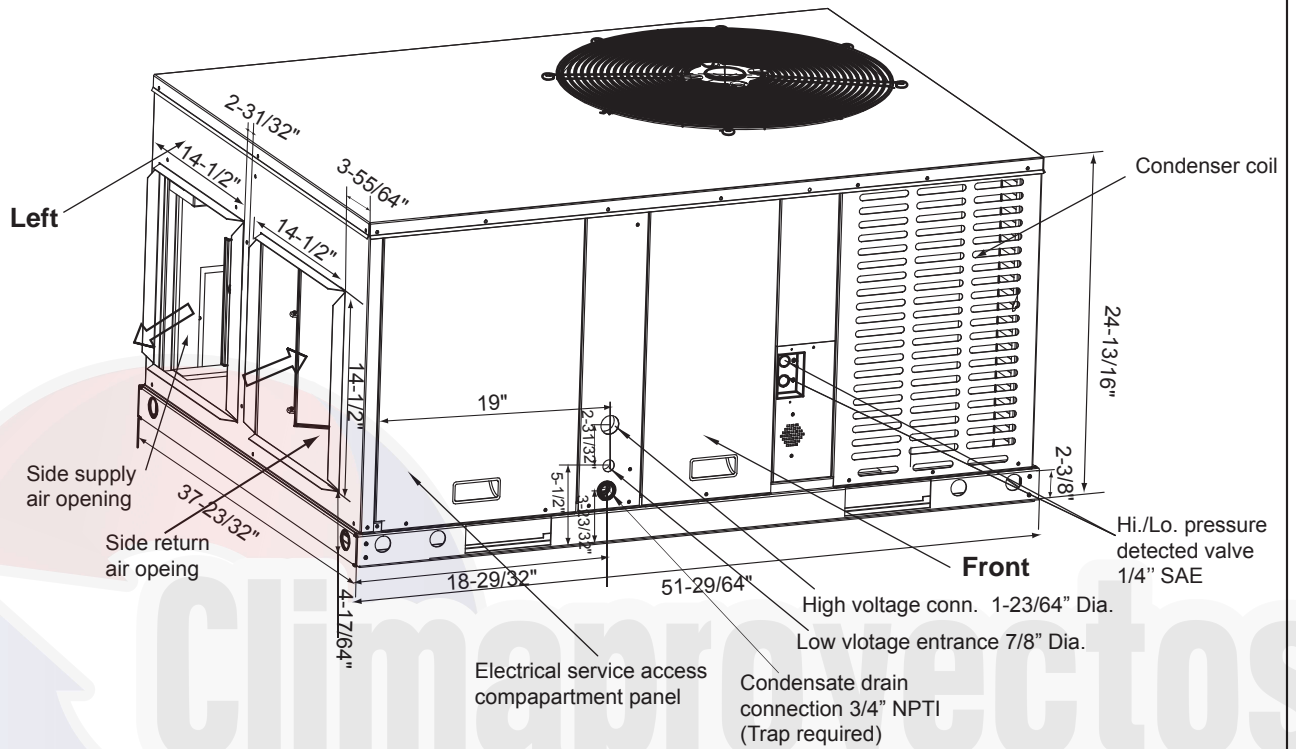

Fig. 2-2 Unit Dimensions

* The above figure for reference purpose only.

Unit size: 048, 060

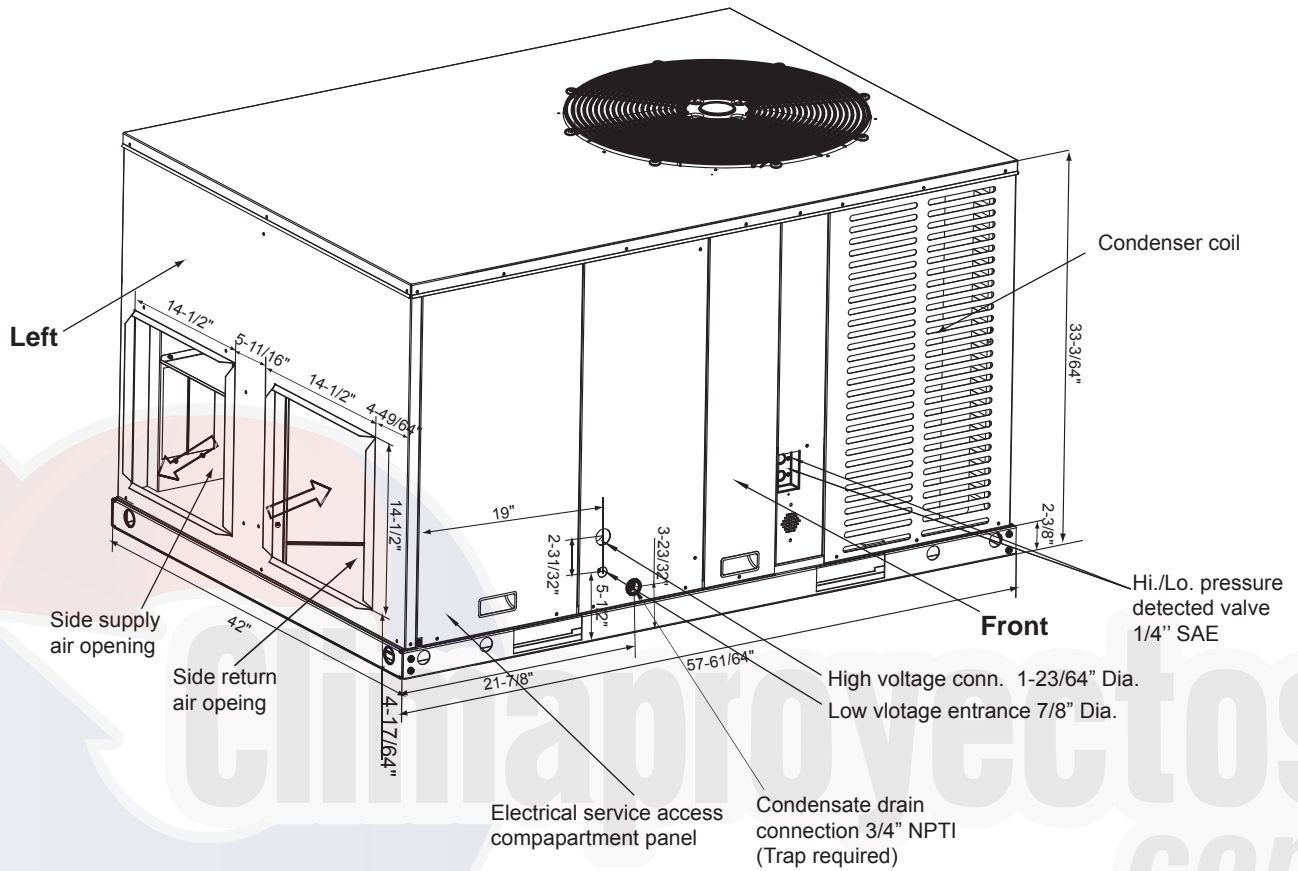

Fig. 2-3 Unit Dimensions

* The above figure for reference purpose only.

Table 2-1: Unit Clearance

Direction	Distance (in.)	Direction	Distance (in.)
Top ¹	60	Right	12
Front	30	Left	24
Rear	18 ²	Bottom ³	0

Duct clearance: 1 inch clearance for all sides of air supply duct.

1. Units must be installed outdoors. Over hanging structure or shrubs should not obscure condenser air discharge outlet.
2. The minimum clearance without economizer/fresh air damper. For distance with Economizer/fresh air damper, please refer to the relevant Install requirement.
3. Units may be installed on combustible floors made from wood or class A, B or C roof covering materials.



NOTE

For units applied with a roof curb, the minimum clearance may be reduced from 1 inch to 1/2 inch between combustible roof curb material and this supply air duct.

3.0 DUCTWORK

Ductwork should be made and sized by installer and in accordance with Air Manual from Conditioning Contractors of America and local codes.

	NOTE
On ductwork exposed to outside air conditioning space, use at least 2" of insulation and a vapor barrier. Flexible joint may be used to reduce noise.	

A closed return duct system shall be used. This shall not preclude use of economizers or ventilation air intake. Flexible joints may be used in the supply and return duct work to minimize the transmission of noise.

	CAUTION
When fastening duct work to the side duct flanges on the unit, insert the screws through the duct flanges only. DO NOT insert the screws through the casing. Outdoor duct work must be insulation and waterproofed.	

	NOTE
Be sure to note supply and return openings. Refer to Fig. 2-2 and 2-3 for information concerning supply and return air duct openings.	

4.0 CONDENSATE DRAIN CONNECTION

Consult local codes for special requirements.

To provide extra protection from water damage, install an additional drain pan, provided by installer, under the entire unit with a separate drain line. Manufacturer will not be responsible for any damages due to the failure to follow these requirements.

4.1 INSTALL DRAIN PIPE

1. Use female NPT threaded fitting for outside connection and make sure that drain holes are not blocked.
2. Insulation may be needed for drain line to prevent sweating.
3. Drain pan has two drain connections on each side to provide flexibility of connection and drainage. Make sure proper pitch and plugging if second connection is not used.
4. Use a sealing compound on male pipe threads. Install the condensate drain line (NPT) to spill into an open drain.

5.0 FILTERS

Units are shipped without a filter or filter racks. It is the responsibility of the installer to secure a filter in the return air ductwork or install a filter/frame Kit.

Filter must always be used and must be kept clean. When filter become dirt laden, insufficient air will be delivered by the blower, decreasing your units efficiency and increasing operation costs and wear-and tear on the unit and controls.

Filters should be checked monthly; this is especially important since this unit is used for both heating and cooling.

6.0 ELECTRICAL WIRING

Field wiring must comply with the National Electric Code (NEC) or Canadian Electrical Code (CEC) and any applicable local ordinance.



WARNING

Disconnect all power to unit before installing or servicing. More than one disconnect switch may be required to de-energize the equipment. Hazardous voltage can cause severe personal injury or death.

6.1 POWER WIRING

1. Proper electrical power should be available at unit. Voltage tolerance should not be over 10% from rating voltage.
2. If any of the wire must be replaced, replacement wire must be the same type as shown in nameplate, wiring diagram and electrical data sheet.
3. Install a branch circuit disconnect of adequate size to handle starting current, located within sight of, and readily accessible to the unit.
4. ELECTRIC HEATER - If the Electric Heater is installed, unit may be equipped with 30~60A. circuit breakers or fuse. These breaker(s) protect the internal wiring in the event of a short circuit and serve as a disconnect. Circuit breakers installed within the unit do not provide over-current protection of the supply wiring and therefore may be sized larger than the branch circuit protection.
 - Supply circuit power wiring must be 221 °F minimum copper conductors only. See Electrical Data in this section for ampacity, wire size and circuit protector requirements. Supply circuit protective devices may be either fuses or "HACR" type circuit breakers.
 - Two 1-3/8" knockouts on the back panel are provided for connection of power wiring to electric heater.
 - Power wiring is connected to the power terminal block in unit electric heater cabinet.

See Electrical Heater Installation Instruction for details.

6.2 GROUNDING



WARNING

The unit must be permanently grounded. Failure to do so can result in electrical shock causing personal injury or death.

- Grounding may be accomplished by grounding metal conduit when installed in accordance with electrical codes to the unit cabinet.
- Grounding may also be accomplished by attaching ground wire(s) to ground lug(s) provided in the unit wiring compartment.

6.3 CONTROL WIRING

IMPORTANT: Class 2 low voltage control wiring SHOULD NOT be run in conduit with main power wiring and must be separated from power wiring, unless class 1 wire of proper voltage rating is used.

- Low voltage control wiring should be 18 AWG color-coded. For lengths longer than 50 ft, 16 AWG wire should be used.
- Two 7/8" holes can be used for control wires going into the unit, one on left side and one at the bottom.
- Make sure, after installation, separation of control wiring and power wiring has been maintained.

Thermostat should be mounted on an inside wall about 58" from floor and will not be affected by unconditioned air, sun and/or heat exposure. Follow the instruction carefully because there are many wiring requirements. See *Fig. 6-1 ~ 2, Table 6-1 ~ 2*

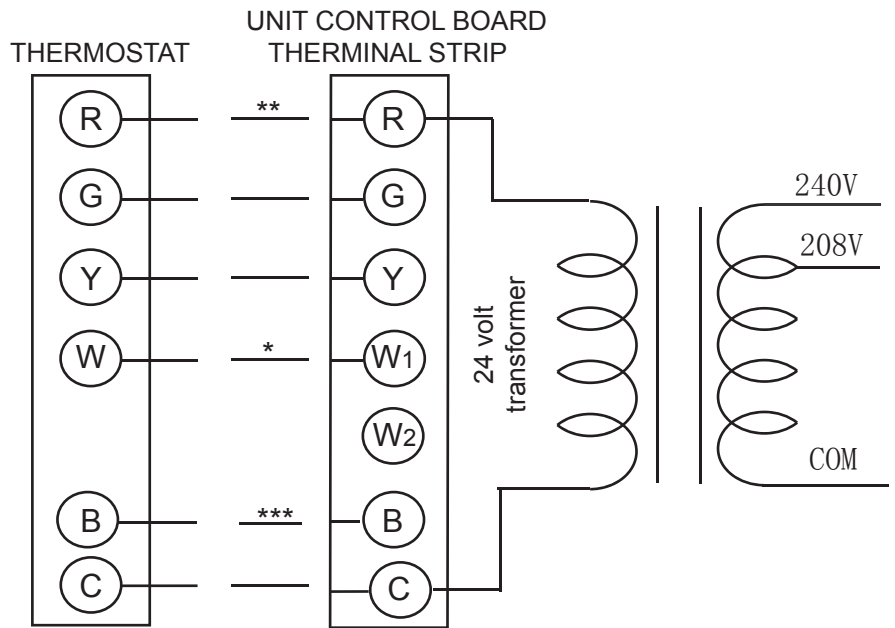

Fig. 6-1 Typical Field Control Wiring Diagram

- *** B wire be used with heat pump system only.
- ** Minimum wire size of 18 AWG wire should be used for all field installed 24 volt wire.
- * Only required on units with supplemental electric heat.



CAUTION

Label all wire prior to disconnection when servicing controls. Wiring errors can cause improper and dangerous operation. Verify proper operation after servicing.

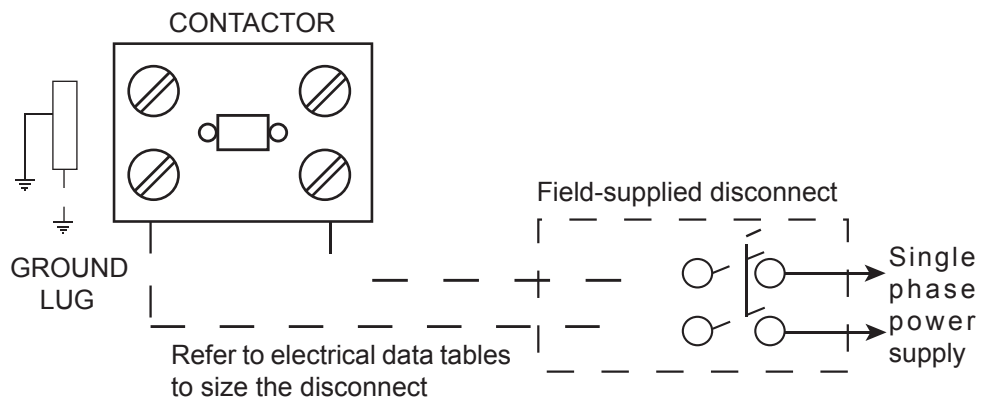

Fig. 6-2 Typical Field Power Wiring Diagram

Table 6-1: 13 SEER Heat Pump W/Without Electric Heat

Size (Tons)	Volt	Compressors (each)			OD Fan Motors (each)	Supply Blower Motor	Electric Heat Option				MCA1 (Amps)	Max Fuse2/ Breaker3 Size (Amps)
		RLA	LRA	MCC	FLA	FLA	Model	kW	Stages	Amps		
024T (2.0)	208/230-1-60	9.7A	34.8A	15.1A	0.61A	1.71A	None	-	-	None	14.5	20
							EHK-05E	3.8/5	1	18.1/20.8	32.6/40.5	40/45
							EHK-08E	5.6/7.5	1	27.1/31.3	41.6/53.6	50/60
							EHK-10E	7.5/10	1	36.1/41.7	50.6/66.6	60/70
036L (3.0)	208/230-1-60	14.0A	70A	18.7A	0.95A	2.84A	None	-	-	None	21.3	30
							EHK-05E	3.8/5	1	18.1/20.8	44.0/47.3	50/50
							EHK-08E	5.6/7.5	1	27.1/31.3	55.2/60.5	60/70
							EHK-10E	7.5/10	1	36.1/41.7	66.5/73.5	70/80
048L (4.0)	208/230-1-60	19.0A	100A	29.6A	1.68A	3.66A	EHK-15E	11.3/15	2	54.2/62.5	89.1/99.5	90/100
							None	-	-	None	29.1	45
							EHK-05E	3.8/5	1	18.1/20.8	47.2/55.1	60/60
							EHK-08E	5.6/7.5	1	27.1/31.3	56.2/68.3	70/80
060L (5.0)	208/230-1-60	21.5A	125A	33.5A	1.68A	3.82A	EHK-10E	7.5/10	1	36.1/41.7	65.2/81.3	80/90
							EHK-15E	11.3/15	2	54.2/62.5	83.3/107.3	100/110
							EHK-20E	15/20	2	72.2/83.3	101.3/133.3	125/150
							None	-	-	None	32.4	50

024T: GMCC compressor
036L/048L/060L: LG compressor

Table 6-2: 13 SEER Cooling only W/Without Electric Heat

Size (Tons)	Volt	Compressors (each)			OD Fan Motors (each)	Supply Blower Motor	Electric Heat Option				MCA1 (Amps)	Max Fuse2/ Breaker3 Size (Amps)
		RLA	LRA	MCC	FLA	FLA	Model	kW	Stages	Amps		
024T (2.0)	208/230-1-60	9.7A	34.8A	15.1A	0.61A	1.71A	None	-	-	None	14.5	20
							EHK-05E	3.8/5	1	18.1/20.8	24.8/28.2	25/30
							EHK-08E	5.6/7.5	1	27.1/31.3	36.1/41.3	40/45
							EHK-10E	7.5/10	1	36.1/41.7	47.3/54.3	50/60
036L (3.0)	208/230-1-60	14.0A	70A	18.7A	0.95A	2.84A	None	-	-	None	21.3	30
							EHK-05E	3.8/5	1	18.1/20.8	26.2/29.6	30/30
							EHK-08E	5.6/7.5	1	27.1/31.3	37.5/42.7	40/45
							EHK-10E	7.5/10	1	36.1/41.7	48.7/55.7	50/60
048L (4.0)	208/230-1-60	19.0A	100A	29.6A	1.68A	3.66A	EHK-15E	11.3/15	2	54.2/62.5	71.3/81.7	80/90
							None	-	-	None	29.1	45
							EHK-05E	3.8/5	1	18.1/20.8	27.2/30.6	30/40
							EHK-08E	5.6/7.5	1	27.1/31.3	38.5/43.7	40/45
060L (5.0)	208/230-1-60	21.5A	125A	33.5A	1.68A	3.82A	EHK-10E	7.5/10	1	36.1/41.7	49.7/56.7	50/60
							EHK-15E	11.3/15	2	54.2/62.5	72.4/82.7	80/90
							EHK-20E	15/20	2	72.2/83.3	94.9/108.7	100/110
							None	-	-	None	32.4	50

024T: GMCC compressor
036L/048L/060L: LG compressor

1. Minimum Circuit Ampacity.
2. Maximum Over Current Protection per Standard UL 1995.
3. Fuse or HACR circuit breaker size installed at factory or field installed.

Table 6-3: 13 SEER Physical Data

Component	Models							
	MRC-24CWN1-M13L	MRC-24HWN1-M13L	MRC-36CWN1-M13L	MRC-36HWN1-M13L	MRC-48CWN1-M13L	MRC-48HWN1-M13L	MRC-60CWN1-M13L	MRC-60HWN1-M13L
Nominal Tonnage	2.0	2.0	3.0	3.0	4.0	4.0	5.0	5.0
ARI COOLING PERFORMANCE								
Gross Capacity @ ARI A point (Btu)	23,935	23,735	35,963	35,563	48,813	48,313	58,075	58,075
ARI net capacity (Btu)	23,000	22,800	34,800	34,000	47,000	46,500	56,000	56,000
EER	10.85	10.85	10.40	10.10	10.90	10.80	10.55	10.40
SEER	13	13	13	13	13	13	13	13
Nominal CFM	730	730	1220	1220	1600	1600	2000	2000
System power (kW)	2.0	2.0	3.2	3.2	4.22	4.22	5.27	5.27
Refrigerant type	R410A	R410A	R410A	R410A	R410A	R410A	R410A	R410A
Refrigerant charge (lb-oz)	3-15	3-15	4-14	5-12	8-3	8-6	8-13	9-1
ARI HEATING PERFORMANCE								
47°F Capacity rating (Btu)	—	22,000	—	34,800	—	47,500	—	57,500
System power (kW)	—	1.85	—	2.80	—	3.95	—	4.65
17°F Capacity rating (Btu)	—	11,200	—	19,000	—	26,500	—	31,000
System power (kW)	—	1.60	—	2.50	—	3.40	—	4.05
HSPF (BTU/Watts-hr.)	—	7.7	—	7.7	—	7.7	—	7.7
DIMENSIONS (Inches)								
Length	51-25/64	51-25/64	51-25/64	51-25/64	57-61/64	57-61/64	57-61/64	57-61/64
Width	37-23/32	37-23/32	37-23/32	37-23/32	42	42	42	42
Height	24-13/16	24-13/16	24-13/16	24-13/16	33-3/64	33-3/64	33-3/64	33-3/64
OPERATING WT. (lbs)	304	309	335	340	445	454	463	472
COMPRESSORS								
Type	Rotary	Rotary	Scroll 1-spd	Scroll 1-spd	Scroll 1-spd	Scroll 1-spd	Scroll 1-spd	Scroll 1-spd
Quantity	1	1	1	1	1	1	1	1
CONDENSER COIL DATA								
Face area (Sq. Ft)	10.17	10.17	10.17	10.17	15.77	15.77	15.77	15.77
Rows	1.5	1.5	2	2	2	2	2.5	2.5
Fins per inch	20	20	20	20	20	20	20	20
Tube diameter(inch)	9/32	9/32	9/32	9/32	9/32	9/32	9/32	9/32
Circuitry type	interlaced	interlaced	interlaced	interlaced	interlaced	interlaced	interlaced	interlaced
EVAPORATOR COIL DATA								
Face area (Sq. Ft)	3.36	3.36	3.36	3.36	6.43	6.43	6.43	6.43
Rows	3	3	4	4	3	3	4	4
Fins per inch	17	17	17	17	17	17	17	17
Tube diameter(inch)	9/32	9/32	9/32	9/32	9/32	9/32	9/32	9/32
Circuitry type	interlaced	interlaced	interlaced	interlaced	interlaced	interlaced	interlaced	interlaced
Refrigerant control	Orifice	Orifice	Orifice	Orifice	Orifice	Orifice	Orifice	Orifice
CONDENSER FAN DATA								
Fan diameter (inch)	22-3/64	22-3/64	22-3/64	22-3/64	23-5/8	23-5/8	23-5/8	23-5/8
Type	Prop	Prop	Prop	Prop	Prop	Prop	Prop	Prop
Drive type	Direct	Direct	Direct	Direct	Direct	Direct	Direct	Direct
No. speeds	1	1	1	1	1	1	1	1
Number of motors	1	1	1	1	1	1	1	1
Motor HP each	1/12	1/12	1/6	1/6	1/3	1/3	1/3	1/3
RPM	1075	1075	825	825	1075	1075	1075	1075
Nominal total CFM	1960	1960	2565	2565	3960	3960	3960	3960
DIRECT DRIVE EVAP FAN DATA								
Quantity	1	1	1	1	1	1	1	1
Fan Size (Inch)	9×9	9×9	9×9	9×9	10×10	10×10	10×10	10×10
Type	Centrifugal	Centrifugal	Centrifugal	Centrifugal	Centrifugal	Centrifugal	Centrifugal	Centrifugal
No. speeds	3	3	3	3	3	3	3	3
Motor HP each	1/4	1/4	3/4	3/4	3/4	3/4	1	1
RPM	1075	1075	1075	1075	1075	1075	1075	1075
Motor frame size	48	48	48	48	48	48	48	48
FILTERS								
(No.) Size Recommended in.	(1) 22×14×1	(1) 22×14×1	(1) 22×14×1	(1) 22×14×1	(1) 22×14×1	(1) 22×14×1	(1) 22×14×1	(1) 22×14×1

7.0 AIRFLOW PERFORMANCE

Airflow performance data is based on cooling performance with a coil and no filter in place. Use this performance table for appropriate unit size, external static applied to unit and allow operation within the minimum and maximum limits shown in table below for both cooling and electric heat operation.

7.1 AIRFLOW PERFORMANCE DATA

Table 7-1 Duct Application(208v)

Model Number	Motor Speed	CFM(L/S)(Watts)								
		External Static Pressure-Inches W.C.[kPa]								
		0[0]	0.1[.02]	0.2[.05]	0.3[.07]	0.4[.10]	0.5[.12]	0.6[.15]	0.7[.17]	
24	Low	CFM(L/S)	756(357)	706 (333)	654 (309)	600(283)				
		RPM	460	553	638	710				
		Watts	161	159	156	152				
		Amps	0.78	0.77	0.75	0.73				
	Middle	CFM(L/S)				842(397)	782(369)	718(339)	625(295)	
		RPM				776	831	884	930	
		Watts				228	220	213	203	
		Amps				1.1	1.06	1.03	0.99	
	High	CFM(L/S)						889(419)	805(380)	693(327)
		RPM						929	970	1004
		Watts						280	266	253
		Amps						1.37	1.32	1.26
36	Low	CFM(L/S)	1170(525)	1143(539)	1110(524)	1070(505)	1021(428)			
		RPM	694	752	806	859	902			
		Watts	390	376	360	343	326			
		Amps	1.88	1.81	1.73	1.66	1.58			
	Middle	CFM(L/S)			1251(590)	1206(569)	1148(541)	1080(509)	989(466)	
		RPM			869	910	949	983	1017	
		Watts			436	416	392	368	340	
		Amps			2.11	2.01	1.91	1.8	1.68	
	High	CFM(L/S)				1345(634)	1272(600)	1192(562)	1107(522)	980(462)
		RPM				965	995	1022	1045	1070
		Watts				499	470	441	413	377
		Amps				2.43	2.31	2.18	2.07	1.91
48	Low	CFM(L/S)	1497(706)	1449(683)	1401(661)	1349(636)	1291(609)			
		RPM	676	722	773	816	853			
		Watts	457	448	437	426	413			
		Amps	2.26	2.22	2.18	2.14	2.08			
	Middle	CFM(L/S)			1571(741)	1511(713)	1445(681)	1370(646)	1249(589)	
		RPM			834	872	905	936	972	
		Watts			527	510	493	473	443	
		Amps			2.65	2.59	2.53	2.46	2.35	
	High	CFM(L/S)				1685(795)	1610(759)	1527(720)	1428(673)	1192(562)
		RPM				927	954	980	1003	1041
		Watts				626	604	580	556	510
		Amps				3.22	3.15	3.07	2.98	2.83
60	Low	CFM(L/S)	1865(879)	1822(859)	1770(835)	1712(808)	1643(775)			
		RPM	851	886	919	948	974			
		Watts	641	620	598	578	555			
		Amps	3.08	2.98	2.88	2.79	2.69			
	Middle	CFM(L/S)			1875(884)	1808(853)	1729(816)	1642(774)	1542(727)	
		RPM			961	984	1005	1024	1043	
		Watts			664	639	613	587	558	
		Amps			3.21	3.11	3.0	2.89	2.78	
	High	CFM(L/S)				1905(898)	1826(861)	1736(819)	1615(762)	1479(698)
		RPM				1017	1034	1049	1063	1079
		Watts				703	677	648	619	585
		Amps				3.44	3.34	3.22	3.1	2.97

Table 7-2 Duct Application(230v)

Model Number	Motor Speed	CFM(L/S)(Watts)									
		External Static Pressure-Inches W.C.[kPa]									
		0[0]	0.1[.02]	0.2[.05]	0.3[.07]	0.4[.10]	0.5[.12]	0.6[.15]	0.7[.17]		
24	Low	CFM(L/S)	847(399)	800 (378)	754 (356)	701(331)					
		RPM	509	591	671	737					
		Watts	195	191	187	183					
		Amps	0.85	0.83	0.81	0.79					
	Middle	CFM(L/S)				932(440)	878(414)	806(380)	725(342)		
		RPM				812	866	911	949		
		Watts				271	261	251	240		
		Amps				1.18	1.14	1.1	1.06		
	High	CFM(L/S)						974(459)	889(419)	794(375)	
		RPM						960	993	1023	
		Watts						328	314	299	
		Amps						1.47	1.41	1.36	
36	Low	CFM(L/S)	1312(619)	1280(604)	1243(586)	1197(565)	1143(539)				
		RPM	770	817	863	902	943				
		Watts	455	442	423	402	380				
		Amps	1.98	1.92	1.85	1.76	1.67				
	Middle	CFM(L/S)			1376(649)	1323(624)	1257(593)	1176(554)	1082(510)		
		RPM			919	951	983	1011	1039		
		Watts			494	470	444	418	388		
		Amps			2.17	2.07	1.97	1.87	1.75		
	High	CFM(L/S)				1451(684)	1372(647)	1279(603)	1178(556)	1041(491)	
		RPM				1005	1028	1050	1069	1089	
		Watts				563	533	502	469	434	
		Amps				2.5	2.38	2.26	2.14	2.0	
48	Low	CFM(L/S)	1676(790)	1623(766)	1568(740)	1510(712)	1443(681)				
		RPM	751	793	833	870	903				
		Watts	536	522	508	493	468				
		Amps	2.42	2.37	2.32	2.27	2.21				
	Middle	CFM(L/S)			1721(812)	1669(787)	1593(751)	1516(715)	1429(674)		
		RPM			891	922	948	973	997		
		Watts			608	591	570	550	529		
		Amps			2.82	2.76	2.69	2.62	2.55		
	High	CFM(L/S)				1822(859)	1742(822)	1661(784)	1566(739)	1455(686)	
		RPM				966	988	1007	1025	1046	
		Watts				725	701	675	650	623	
		Amps				3.44	3.36	3.27	3.20	3.12	
60	Low	CFM(L/S)	2037(961)	1984(936)	1936(913)	1859(877)	1780(840)				
		RPM	932	957	980	1001	1020				
		Watts	721	700	676	651	625				
		Amps	3.15	3.06	2.96	2.87	2.77				
	Middle	CFM(L/S)			1998(943)	1931(911)	1855(875)	1757(829)	1654(780)		
		RPM			1010	1027	1043	1056	1071		
		Watts			729	706	677	651	623		
		Amps			3.24	3.14	3.04	2.94	2.83		
	High	CFM(L/S)				2006(946)	1916(904)	1817(857)	1710(807)	1582(746)	
		RPM				1053	1065	1076	1086	1097	
		Watts				778	753	724	694	661	
		Amps				3.5	3.4	3.3	3.19	3.07	

* The above airflow data for reference only.

* In any situation , the airflow of the unit should be in the range of 80% to 130% of 400CFM/Ton.

- The air distribution system has the greatest effect on airflow. The duct system is totally controlled by the contractor. For this reason, the contractor should use only industry-recognized procedures.
- Heat pump systems require a specified airflow. Each ton of cooling requires between 350 and 450 cubic feet of air per minute (CFM), or 400 CFM nominally.
- Duct design and construction should be carefully done. System performance can be lowered dramatically through bad planning or workmanship.
- Air supply diffusers must be selected and located carefully. They must be sized and positioned to deliver treated air along the perimeter of the space. If they are too small for their intended airflow, they become noisy. If they are not located properly, they cause drafts. Return air grilles must be properly sized to carry air back to the blower. If they are too small, they also cause noise.
- The installers should balance the air distribution system to ensure proper quiet airflow to all rooms in the home. This ensures a comfortable living space.
- An air velocity meter or airflow hood can give a reading of system CFM.
- When installation, installer should select the air speed according to the actual setting static pressure. Please refer to the *Table 7-1 AIRFLOW PERFORMANCE DATA*.

Table 7-3 Refrigerant charge for A/C system

MRC-24CWN1-M13T Cooling Mode Mode De Refroidissement		Cooling Charge Chart/Tableau De Charge de Refroidissement											
		Outdoor Ambient Temperature(°F)/Temperature Amdiante Exterieur(en °F)											
		55	60	65	70	75	80	85	90	95	100	105	110
Low Pressure Detected Valve(psig) Vanne Détectée de Pression Basse(en psig)		High Pressure Detected Valve(psig)/Vanne Détecté de Pression Haute(en psig)											
		165			284	304	325	345	365	385	405	430	455
161			282	302	323	343	363	383	403	428	453	478	503
157			280	300	321	341	361	381	401	426	451	476	501
153		258	278	298	319	339	359	379	399	424	449	474	499
149		256	276	296	317	337	357	377	397	422	447	472	497
145		253	274	295	316	337	355	372	390	416	443	469	495
141	230	251	272	293	314	335	353	370	388	414	441	467	493
137	228	249	270	291	312	333	351	368	386	412	439	465	491
133	226	247	268	289	310	331	349	366	384	410	437	463	489
129	224	245	266	287	308	329	347	364	382	408	435	461	487
125	222	243	264	285	306	327	345	362	380	406	433	459	485
121	220	241	262	283	304	325	343	360	378	404	431	457	483
117	218	239	260	281	302	323	341	358	376	402	429	455	481
113	216	237	258	279	300	321	339	356	374	400	427	453	479
109	214	235	256	277	298	319	337	354	372	398	425	451	477
105	212	233	254	275	296	317	335	352	370	396	423	449	475

Table 7-4 Refrigerant charge for H/P system

MRC-24HWN1-M13T Cooling Mode Mode De Refroidissement		Cooling Charge Chart/Tableau De Charge de Refroidissement											
		Outdoor Ambient Temperature(°F)/Temperature Amdiante Exterieur(en °F)											
		55	60	65	70	75	80	85	90	95	100	105	110
Low Pressure Detected Valve(psig) Vanne Détectée de Pression Basse(en psig)		High Pressure Detected Valve(psig)/Vanne Détecté de Pression Haute(en psig)											
		165			284	305	326	347	367	386	406	431	456
161			282	303	324	345	365	384	404	429	454	478	503
157			280	301	322	343	363	382	402	427	452	476	501
153		257	278	299	320	341	361	380	400	425	450	474	499
149		255	276	297	318	339	359	378	398	423	448	472	497
145		253	274	295	316	337	356	376	395	420	445	470	495
141	230	251	272	293	314	335	354	374	393	418	443	468	493
137	228	249	270	291	312	333	352	372	391	416	441	466	491
133	226	247	268	289	310	331	350	370	389	414	439	464	489
129	224	245	266	287	308	329	348	368	387	412	437	462	487
125	222	243	264	285	306	327	346	366	385	410	435	460	485
121	220	241	262	283	304	325	344	364	383	408	433	458	483
117	218	239	260	281	302	323	342	362	381	406	431	456	481
113	216	237	258	279	300	321	340	360	379	404	429	454	479
109	214	235	256	277	298	319	338	358	377	402	427	452	477
105	209	230	252	274	295	317	336	356	375	400	425	450	475

Table 7-5 Refrigerant charge for H/P system

MRC-24HWN1-M13T Heating Mode Mode De Chauffage		Heating Charge Chart/Tableau De Charge de Chauffage											
		Indoor Dry Bulb Temperature(°F)/Temperature Interieur au Themometre sec(en °F)											
		60	62	64	66	68	70	72	74	76	78	80	82
Low Pressure Detected Valve(psig) Vanne Détectée de Pression Basse(en psig)		High Pressure Detected Valve(psig)/Vanne Détecté de Pression Haute(en psig)											
		135	341	349	356	361	368	375	383	389	393	398	404
128	330	342	350	356	362	369	375	381	387	391	396	401	
121	316	324	343	349	354	362	367	374	380	385	392	396	
114	305	312	325	339	347	356	361	368	373	378	383	388	
107	297	301	312	327	340	349	354	361	367	372	377	383	
100	283	289	301	316	333	342	348	354	359	363	370	375	
93	274	281	290	301	322	331	339	345	352	358	363	369	
86	261	276	284	290	307	320	325	336	341	350	356	361	
79	256	272	281	290	302	311	317	326	331	340	347	352	
72	241	251	262	272	280	294	310	317	323	331	340	346	
65	231	240	250	262	271	283	296	308	312	320	329	339	
58					261	270	277	298	309	313	318	325	
51						262	271	278	297	302	308	316	
44							262	268	277	289	294	308	
37								259	263	274	288	296	
30													

Table 7-6 Refrigerant charge for A/C system

MRC-36CWN1-M13L Cooling Mode Mode De Refroidissement		Cooling Charge Chart/Tableau De Charge de Refroidissement													
		Outdoor Ambient Temperature(°F)/Temperature Amdiante Exterieur(en °F)													
		55	60	65	70	75	80	85	90	95	100	105	110	115	
Low Pressure Detected Valve(psig) Vanne Détectée de Pression Basse(en psig)		High Pressure Detected Valve(psig)/Vanne Détecté de Pression Haute(en psig)													
		165			289	308	328	347	372	398	423	454	485	516	547
		161			287	306	326	345	370	396	421	452	483	514	545
		157			285	304	324	343	368	394	419	450	481	512	543
		153		264	283	302	322	341	366	392	417	448	479	510	541
		149		262	281	300	320	339	364	390	415	446	477	508	539
		145		260	279	298	318	337	362	388	413	444	475	506	537
		141	238	258	277	296	316	335	360	386	411	442	473	504	535
		137	236	256	275	294	314	333	358	384	409	440	471	502	533
		133	234	254	273	292	312	331	356	382	407	438	469	500	531
		129	232	252	271	290	310	329	354	380	405	436	467	498	529
		125	230	250	269	288	308	327	352	378	403	434	465	496	527
		121	228	248	267	286	306	325	350	376	401	432	463	494	525
		117	226	246	265	284	304	323	348	374	399	430	461	492	523
		113	224	244	263	282	302	321	346	372	397	428	459	490	521
109	222	242	261	280	300	319	344	370	395	426	457	488	519		
105	220	240	259	278	298	317	342	368	393	424	455	486	517		

Table 7-7 Refrigerant charge for H/P system

MRC-36HWN1-M13L Cooling Mode Mode De Refroidissement		Cooling Charge Chart/Tableau De Charge de Refroidissement													
		Outdoor Ambient Temperature(°F)/Temperature Amdiante Exterieur(en °F)													
		55	60	65	70	75	80	85	90	95	100	105	110	115	
Low Pressure Detected Valve(psig) Vanne Détectée de Pression Basse(en psig)		High Pressure Detected Valve(psig)/Vanne Détecté de Pression Haute(en psig)													
		165			298	322	345	369	388	408	427	458	488	519	549
		161			296	320	343	367	386	406	425	456	486	517	547
		157			294	318	341	365	384	404	423	454	484	515	545
		153		268	292	316	339	363	382	402	421	452	482	513	543
		149		266	290	314	337	361	380	400	419	450	480	511	541
		145		264	288	312	335	359	378	397	416	447	478	508	539
		141	239	263	286	309	333	356	375	395	414	445	476	506	537
		137	237	261	284	307	331	354	373	393	412	443	474	504	535
		133	235	259	282	305	329	352	371	391	410	441	472	502	533
		129	233	257	280	303	327	350	369	389	408	439	470	500	531
		125	231	255	278	301	325	348	367	387	406	437	468	498	529
		121	229	253	276	299	323	346	365	385	404	435	466	496	527
		117	227	251	274	297	321	344	363	383	402	433	464	494	525
		113	224	247	271	295	318	342	361	381	400	431	462	492	523
109	222	245	269	293	316	340	359	379	398	429	460	490	521		
105	220	243	267	291	314	338	357	377	396	427	458	488	519		

Table 7-8 Refrigerant charge for H/P system

MRC-36HWN1-M13L Heating Mode Mode De Chauffage		Heating Charge Chart/Tableau De Charge de Chauffage														
		Indoor Dry Bulb Temperature(°F)/Temperature Interieur au Themometre sec(en °F)														
		60	62	64	66	68	70	72	74	76	78	80	82			
Low Pressure Detected Valve(psig) Vanne Détectée de Pression Basse(en psig)		High Pressure Detected Valve(psig)/Vanne Détecté de Pression Haute(en psig)														
		135	328	341	350	358	364	367	372	378	383	387	393	401		
		128	322	331	342	350	357	360	365	371	376	381	386	392		
		121	313	320	333	341	346	352	360	365	371	376	379	386		
		114	305	314	325	332	340	347	353	359	366	372	377	380		
		107	296	306	314	323	330	340	346	352	358	365	372	376		
		100	288	294	303	311	319	332	339	345	351	358	364	368		
		93	280	285	296	303	311	323	330	337	345	352	357	361		
		86	271	278	284	292	303	312	321	328	335	344	353	356		
		79	263	267	271	280	291	302	311	319	324	336	341	347		
		72	251	256	260	268	279	291	303	310	315	318	329	338		
		65	241	245	249	254	261	277	285	292	304	309	318	326		
		58					252	265	276	282	296	302	311	318		
		51						254	262	268	284	289	301	310		
		44							255	260	269	273	288	295		
37								254	261	265	275	282				
30																

Table 7-9 Refrigerant charge for A/C system

MRB-48CWN1-M13L Cooling Mode Mode De Refroidissement		Cooling Charge Chart/Tableau De Charge de Refroidissement													
		Outdoor Ambient Temperature(°F)/Temperature Amiante Exterieur(en °F)													
		55	60	65	70	75	80	85	90	95	100	105	110	115	
Low Pressure Detected Valve(psig) Vanne Détectée de Pression Basse(en psig)		High Pressure Detected Valve(psig)/Vanne Détecté de Pression Haute(en psig)													
		165			284	307	329	352	372	392	412	439	467	494	521
		161			282	305	327	350	370	390	410	437	464	491	518
		157			280	303	325	348	368	388	408	435	462	489	516
		153		255	278	301	323	346	366	386	406	433	460	487	514
		149		253	276	299	321	344	364	384	404	431	458	485	512
		145		251	274	297	319	342	362	382	402	429	456	483	510
		141	227	249	272	295	317	340	358	376	394	423	451	480	508
		137	225	247	270	293	315	338	358	378	398	425	452	479	506
		133	223	245	268	291	313	336	356	376	396	423	450	477	504
		129	221	243	266	289	311	334	354	374	394	421	448	475	502
		125	219	241	264	287	309	332	352	372	392	419	446	473	500
		121	217	239	262	285	307	330	350	370	390	417	444	471	498
		117	215	237	260	283	305	328	348	368	388	415	442	469	496
		113	211	234	257	280	303	326	346	366	386	413	440	467	494
109	209	232	255	278	301	324	344	364	384	411	438	465	492		
105	207	230	253	276	299	322	342	362	382	409	436	463	490		

Table 7-10 Refrigerant charge for H/P system

MRB-48HWN1-M13L Cooling Mode Mode De Refroidissement		Cooling Charge Chart/Tableau De Charge de Refroidissement													
		Outdoor Ambient Temperature(°F)/Temperature Amiante Exterieur(en °F)													
		55	60	65	70	75	80	85	90	95	100	105	110	115	
Low Pressure Detected Valve(psig) Vanne Détectée de Pression Basse(en psig)		High Pressure Detected Valve(psig)/Vanne Détecté de Pression Haute(en psig)													
		165			282	305	329	352	372	392	412	437	461	486	510
		161			280	303	327	350	370	390	410	435	459	484	508
		157			278	301	325	348	368	388	408	433	457	482	506
		153		253	276	299	323	346	366	386	406	431	455	480	504
		149		251	274	297	321	344	364	384	404	429	453	478	502
		145		249	272	295	319	342	362	382	402	427	451	476	500
		141	223	247	270	293	317	340	358	376	394	420	446	472	498
		137	221	245	268	291	315	338	357	377	396	421	446	471	496
		133	219	243	266	289	313	336	355	375	394	419	444	469	494
		129	219	241	264	287	309	332	352	372	392	417	442	467	492
		125	217	239	262	285	307	330	350	370	390	415	440	465	490
		121	215	237	260	283	305	328	348	368	388	413	438	463	488
		117	213	235	258	281	303	326	346	366	386	411	436	461	486
		113	211	233	256	279	301	324	344	364	384	409	434	459	484
109	209	231	254	277	299	322	342	362	382	407	432	457	482		
105	207	229	252	275	297	320	340	360	380	405	430	455	480		

Table 7-11 Refrigerant charge for H/P system

MRB-48HWN1-M13L Heating Mode Mode De Chauffage		Heating Charge Chart/Tableau De Charge de Chauffage													
		Indoor Dry Bulb Temperature(°F)/Temperature Interieur au Themometre sec(en °F)													
		60	62	64	66	68	70	72	74	76	78	80	82		
Low Pressure Detected Valve(psig) Vanne Détectée de Pression Basse(en psig)		High Pressure Detected Valve(psig)/Vanne Détecté de Pression Haute(en psig)													
		135	333	340	348	353	361	368	375	381	388	394	400	408	
		128	324	332	339	347	353	360	367	372	379	385	393	401	
		121	313	323	329	336	348	353	359	366	371	378	384	395	
		114	306	314	322	330	338	347	352	359	363	370	377	386	
		107	295	305	313	321	331	339	345	353	358	364	371	378	
		100	286	294	304	312	323	332	338	345	351	357	363	370	
		93	277	285	293	302	315	325	329	337	344	350	358	362	
		86	267	276	285	291	304	312	319	328	338	342	349	356	
		79	258	265	271	281	295	303	308	316	323	333	341	347	
		72	243	253	260	270	283	294	301	309	317	325	332	340	
		65	231	241	247	255	269	281	288	295	310	317	326	333	
		58					254	268	275	282	297	308	317	325	
		51						255	263	273	283	299	308	316	
		44							255	264	274	289	297	307	
37								254	265	276	288	298			
30															

Table 7-12 Refrigerant charge for A/C system

MRB-60CWN1-M13L Cooling Mode Mode De Refroidissement		Cooling Charge Chart/Tableau De Charge de Refroidissement													
		Outdoor Ambient Temperature(°F)/Temperature Amdiante Exterieur(en °F)													
		55	60	65	70	75	80	85	90	95	100	105	110	115	
		High Pressure Detected Valve(psig)/Vanne Détecté de Pression Haute(en psig)													
Low Pressure Detected Valve(psig)	Vanne Détectée de Pression Basse(en psig)	165			290	311	333	354	375	396	417	450	482	515	547
		161			288	309	331	352	373	394	415	448	480	513	545
		157			286	307	329	350	371	392	413	446	478	511	543
		153		263	284	305	327	348	369	390	411	444	476	509	541
		149		261	282	303	325	346	367	388	409	442	474	507	539
		145		259	280	301	323	344	365	386	407	440	472	505	537
		141	235	257	278	299	321	342	363	384	405	438	470	503	535
		137	233	254	276	298	319	341	360	379	398	432	466	499	533
		133	231	252	274	296	317	339	358	377	396	430	464	497	531
		129	229	251	272	294	315	337	356	375	394	428	462	495	529
		125	227	249	270	292	313	335	354	373	392	426	460	493	527
		121	225	247	268	290	311	333	352	371	390	424	458	491	525
		117	223	245	266	288	309	331	350	369	388	422	456	489	523
		113	221	243	264	286	307	329	348	367	386	420	454	487	521
		109	219	241	262	284	305	327	346	365	384	418	452	485	519
105	217	239	260	282	303	325	344	363	382	416	450	483	517		

Table 7-13 Refrigerant charge for H/P system

MRB-60HWN1-M13L Cooling Mode Mode De Refroidissement		Cooling Charge Chart/Tableau De Charge de Refroidissement													
		Outdoor Ambient Temperature(°F)/Temperature Amdiante Exterieur(en °F)													
		55	60	65	70	75	80	85	90	95	100	105	110	115	
		High Pressure Detected Valve(psig)/Vanne Détecté de Pression Haute(en psig)													
Low Pressure Detected Valve(psig)	Vanne Détectée de Pression Basse(en psig)	165			290	311	333	354	377	400	423	450	478	505	532
		161			288	309	331	352	375	398	421	448	476	503	530
		157			286	307	329	350	373	396	419	446	474	501	528
		153		263	284	305	327	348	371	394	417	444	472	499	526
		149		261	282	303	325	346	369	392	415	442	470	497	524
		145		259	280	301	323	344	367	390	413	440	468	495	522
		141	235	257	278	299	321	342	365	388	411	438	466	493	520
		137	228	252	276	300	324	348	368	389	409	436	464	491	518
		133	231	252	274	296	317	339	362	384	407	434	462	489	516
		129	229	251	272	294	315	337	359	382	405	432	460	487	514
		125	227	249	270	292	313	335	357	380	403	430	458	485	512
		121	225	247	268	290	311	333	355	378	401	428	456	483	510
		117	223	245	266	288	309	331	353	376	399	426	454	481	508
		113	223	244	265	286	307	329	351	374	397	424	452	479	506
		109	221	242	263	284	305	327	349	372	395	422	450	477	504
105	219	240	261	282	303	325	347	370	393	420	448	475	502		

Table 7-14 Refrigerant charge for H/P system

MRB-60HWN1-M13L Heating Mode Mode De Chauffage		Heating Charge Chart/Tableau De Charge de Chauffage													
		Indoor Dry Bulb Temperature(°F)/Temperature Interieur au Themometre sec(en °F)													
		60	62	64	66	68	70	72	74	76	78	80	82		
		High Pressure Detected Valve(psig)/Vanne Détecté de Pression Haute(en psig)													
Low Pressure Detected Valve(psig)	Vanne Détectée de Pression Basse(en psig)	135	333	338	345	354	361	369	375	382	390	397	408	415	
		128	321	327	337	346	353	360	368	374	383	391	396	407	
		121	312	320	328	338	345	352	361	367	375	384	390	398	
		114	301	311	319	329	337	345	353	360	366	375	383	390	
		107	289	299	310	318	326	334	346	352	359	366	375	382	
		100	276	288	298	309	317	325	335	344	351	358	367	374	
		93	266	275	287	297	308	314	326	333	343	350	359	366	
		86	257	267	276	289	298	305	315	325	332	342	351	358	
		79	249	256	268	277	287	294	306	313	324	333	343	351	
		72	240	247	254	269	276	286	295	307	311	325	332	342	
		65				256	267	278	287	296	305	314	324	331	
		58					258	270	278	286	293	303	315	322	
		51						260	267	275	284	295	304	314	
		44							261	266	269	285	297	305	
		37								258	263	272	280	299	
		30													

8.0 SYSTEM OPERATION

8.1 COMPRESSOR CRANKCASE HEATER(OPTIONAL)

Refrigerant migration during the off cycle can result in a noisy start up. Add a crankcase heater to minimize refrigeration migration, and to help eliminate any start up noise or bearing "wash out".

All heaters are located on the lower half of the compressor shell. Its purpose is to drive refrigerant from the compressor shell during long off cycles, thus preventing damage to the compressor during start-up.

At initial start-up or after extended shutdown periods, make sure the heater is energized for at least 12 hours before the compressor is started. (Disconnect switch on and wall thermostat off.)

The crankcase heater start-up conditions:

If the outdoor ambient temp. is $< 37.4^{\circ}\text{F}$ and the compressor stopped for more than three hours or the unit powered on once more, the crank heater will be on.

Crankcase heater shut-down conditions:

If the outdoor ambient temp. is $> 44.6^{\circ}\text{F}$ or the compressor start running ,the crank heater will be off.

8.2 Protection

8.2.1 Protection for AC system

Discharge temperature protection :

When discharge temp. is $> 275^{\circ}\text{F}$, the compressor will be off,

When discharge temp. is $< 194^{\circ}\text{F}$, the compressor will start running.

8.2.2 Protection for HP system

When the sensor(T3&T4) was checked open-circuit or short-circuit, the compressor ,outdoor fan motor and 4-way valve will be off.

Discharge temperature protection:

When discharge temp. is $> 275^{\circ}\text{F}$, the compressor will be off, When discharge temp. is $< 194^{\circ}\text{F}$, the compressor will start running.

Low pressure protection

When low pressure is < 21 PSIG, the compressor and the outdoor fan motor will stop running.

When low pressure is > 44 PSIG, the compressor and the outdoor fan motor will start running (3 minutes delay necessary).

In stand-by status, if low pressure protection was checked out, the compressor would not start running.

If protection cycles occur four times within 30 mins, the system must power on once more.

T4 function:

When T4 is < 5 °F, the compressor will stop. If the electrical heater kit is installed in the indoor unit, the outdoor unit will send the operation signal to the indoor unit.

When T4 is > 10.4 °F, the compressor will restart

8.3 DEFROST MODE* (For HP system only)

Defrosting condition:

When JUMP switch is set to "1", the defrost mode will start if one of following conditions is satisfied:

1. Compressor keeps running, when T4 is > 28.4 °F and T3 is < 32 °F and last for 40 minutes;
2. Compressor keeps running, when T4 is < 28.4 °F and T3 is < 32 °F and last for 50 minutes.

* When defrosting actions, if the electrical heater kit is installed, the unit would deliver the Aux. heater operation signal to the electrical heater kit.

When JUMP switch is set to "0":

Compressor keeps running, when T3 is < 32 °F and last for 30 minutes.

Ending conditions of defrost mode:

The mode will end if one of following conditions is satisfied:

1. The defrosted time lasting for 10 minutes;
2. When JUMP switch is set to "1", T3 is ≥ 64.4 °F;
3. When JUMP switch is set to "0", T3 is ≥ 77 °F.

8.4 MANUAL DEFROST MODE (For HP system only)

When MANUAL DEFROST switch in PCB is set to "1", system will perform as above 8.3 description.

When the switch is set to "0", T3 < 32 °F, compressor keeps running and lasting for 40 seconds, the system turns to the Defrost Mode. By the logic of 8.3 to exit the Defrost Mode.

Caution: Once finishes the manual defrost, please switch the MANUAL DEFROST in PCB to "1".

8.5 THERMOSTAT SIGNALS

Table 8-1: Thermostat Signals

Signal	State	Board Function
G	ON	Blower instant ON
	OFF	Blower 90 sec. delay OFF
G & W1	ON	Blower instant ON Heater bank 1 elec.onstant ON
	OFF	Heater bank 1 elec.instant OFF Blower 90 sec. delay OFF
G & W & W2	ON	Blower instant ON Heater 1 instant ON Heater 2 instant ON
	OFF	Blower 90 sec. delay OFF Heater 1 instant OFF Heater 2 instant OFF
G & Y	ON	Blower instant ON Compressor and outdoor fan instant ON
	OFF	Compressor and outdoor fan instant OFF Blower fan delay 90 sec. OFF
G & B & Y	ON	Blower instant ON Compressor and outdoor fan instant ON 4-way valve instant ON
	OFF	Compressor and outdoor fan instant OFF Blower fan delay 90 sec. OFF 4-way valve instant OFF
G & B & Y & W1	ON	Blower instant ON Compressor and outdoor fan instant ON 4-way valve instant ON Heater 1 instant ON
	OFF	Blower fan delay 90 sec. OFF Compressor and outdoor fan instant OFF 4-way valve instant OFF Heater 1 instant OFF
G & B & Y & W1 & W2	ON	Blower instant ON Compressor and outdoor fan instant ON 4-way valve instant ON Heater 1 instant ON Heater 2 instant ON
	OFF	Blower fan delay 90 sec. OFF Compressor and outdoor fan instant OFF 4-way valve instant OFF Heater 1 instant OFF Heater 2 instant OFF

9.0 OPERATION CHECK-UP

- **Cooling Startup**

1. Turn thermostat to OFF and turn power to ON
2. Turn ON thermostat and set as high as possible
3. Turn Fan switch ON and indoor blower should run
4. Turn fan switch to AUTO, system switch to COOL and thermostat temperature setting below room temperature.
Unit should run in COOLING mode.

- **Heating Startup**

After normal cooling run

1. Turn thermostat switch to HEAT. After unit stops, wait about 5 minutes.
2. Turn thermostat setting above room temperature.
Unit should run in HEATING mode.

After unit has run for a while, check the following:

1. Are fans running properly?
2. Is compressor running correctly?
3. Check refrigerant charge.
4. Check duct connection and leaks.
5. Check tubing and sheet metal rattles.

(See Wiring Diagram for electric connection detail.)

10.0 TROUBLE SHOOTING



WARNING

Components trouble shooting requires opening control box with power on. Use extreme care while working on this condition. Check nameplate and this instruction when making wire connections.

AC System Wiring Diagram (GMCC & LG compressor):

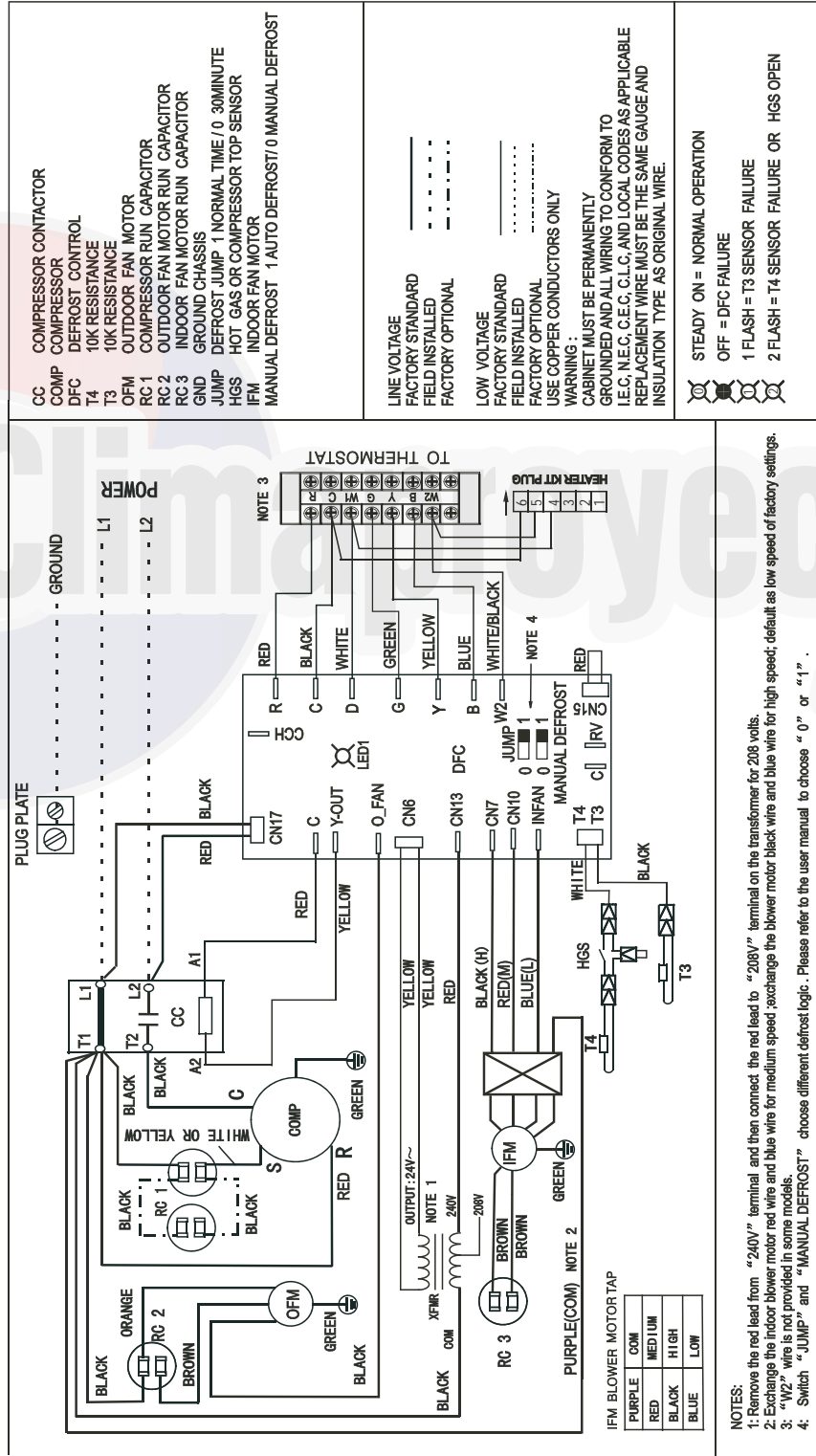

HP System Wiring Diagram (GMCC & LG compressor):

