

SERVICE MANUAL

MIDEA AIRCONDITIONER
DC INVERTER
SPLIT WALL-MOUNTED TYPE

Climaproyectos
.com

CONTENTS

1. Precaution	1
1.1 Safety Precaution.....	1
1.2 Warning.....	1
2. Function	6
3. Dimension	8
3.1 Indoor Units.....	8
3.2 Outdoor Units.....	11
4. Refrigerant Cycle Diagram	12
5. Wiring Diagram	14
5.1 Indoor Units.....	14
5.2 Outdoor Units.....	19
6. Installation details	25
6.1 Wrench torque sheet for installation	25
6.2 Connecting the cables	26
6.3 Pipe length and the elevation	27
6.4 Installation for the first time.....	28
6.5 Adding the refrigerant after running the system for many years	31
6.6 Re-installation while the indoor unit need to be repaired	32
6.7 Re-installation while the outdoor unit need to be repaired	34
7. Operation characteristics	37
8. Electronic function	38
8.1 Abbreviation	38
8.2 Display function.....	38
8.3 Main Protection	39
8.4 Operation Modes and Functions.....	40
9. Troubleshooting	54
9.1 Indoor Unit Error Display.....	55
9.2 Outdoor unit error display	57
9.3 Diagnosis and Solution	59

1. Precaution

1.1 Safety Precaution

- To prevent injury to the user or other people and property damage, the following instructions must be followed.
- Incorrect operation due to ignoring instruction will cause harm or damage.
- Before service unit, be sure to read this service manual at first.

1.2 Warning

➤ Installation

- Do not use a defective or underrated circuit breaker. Use this appliance on a dedicated circuit.

There is risk of fire or electric shock.

- For electrical work, contact the dealer, seller, a qualified electrician, or an Authorized service center.

Do not disassemble or repair the product, there is risk of fire or electric shock.

- Always ground the product.

There is risk of fire or electric shock.

- Install the panel and the cover of control box securely.

There is risk of fire of electric shock.

- Always install a dedicated circuit and breaker.

Improper wiring or installation may cause fire or electric shock.

- Use the correctly rated breaker or fuse.

There is risk of fire or electric shock.

- Do not modify or extend the power cable.

There is risk of fire or electric shock.

- Do not install, remove, or reinstall the unit by yourself(customer).

There is risk of fire, electric shock, explosion, or injury.

- Be caution when unpacking and installing the product.

Sharp edges could cause injury, be especially careful of the case edges and the fins on the

condenser and evaporator.

- **For installation, always contact the dealer or an Authorized service center.**

There is risk of fire, electric shock, explosion, or injury.

- **Do not install the product on a defective installation stand.**

It may cause injury, accident, or damage to the product.

- **Be sure the installation area does not deteriorate with age.**

If the base collapses, the air conditioner could fall with it, causing property damage, product failure, and personal injury.

- **Do not let the air conditioner run for a long time when the humidity is very high and a door or a window is left open.**

Moisture may condense and wet or damage furniture.

- **Take care to ensure that power cable could not be pulled out or damaged during operation.**

There is risk of fire or electric shock.

- **Do not place anything on the power cable.**

There is risk of fire or electric shock.

- **Do not plug or unplug the power supply plug during operation.**

There is risk of fire or electric shock.

- **Do not touch (operation) the product with wet hands.**

There is risk of fire or electric shock.

- **Do not place a heater or other appliance near the power cable.**

There is risk of fire and electric shock.

- **Do not allow water to run into electric parts.**

It may cause fire, failure of the product, or electric shock.

- **Do not store or use flammable gas or combustible near the product.**

There is risk of fire or failure of product.

- **Do not use the product in a tightly closed space for a long time.**

Oxygen deficiency could occur.

- **When flammable gas leaks, turn off the gas and open a window for ventilation before turn the product on.**

Do not use the telephone or turn switches on or off.

There is risk of explosion or fire.

- **If strange sounds, or small or smoke comes from product. Turn the breaker off or disconnect the power supply cable.**

There is risk of electric shock or fire.

- **Stop operation and close the window in storm or hurricane. If possible, remove the product from the window before the hurricane arrives.**

There is risk of property damage, failure of product, or electric shock.

- **Do not open the inlet grill of the product during operation. (Do not touch the electrostatic filter, if the unit is so equipped.)**

There is risk of physical injury, electric shock, or product failure.

- **When the product is soaked (flooded or submerged), contact an Authorized service center.**

There is risk of fire or electric shock.

- **Be caution that water could not enter the product.**

There is risk of fire, electric shock, or product damage.

- **Ventilate the product from time to time when operating it together with a stove, etc.**

There is risk of fire or electric shock.

- **Turn the main power off when cleaning or maintaining the product.**

There is risk of electric shock.

- **When the product is not be used for a long time, disconnect the power supply plug or turn off the breaker.**

There is risk of product damage or failure, or unintended operation.

- **Take care to ensure that nobody could step on or fall onto the outdoor unit.**

This could result in personal injury and product damage.

➤ CAUTION

- **Always check for gas (refrigerant) leakage after installation or repair of product.**

Low refrigerant levels may cause failure of product.

- **Install the drain hose to ensure that water is drained away properly.**

A bad connection may cause water leakage.

- **Keep level even when installing the product.**

It can avoid vibration of water leakage.

- **Do not install the product where the noise or hot air from the outdoor unit could damage the neighborhoods.**

It may cause a problem for your neighbors.

- **Use two or more people to lift and transport the product.**

Avoid personal injury.

- **Do not install the product where it will be exposed to sea wind (salt spray) directly.**

It may cause corrosion on the product. Corrosion, particularly on the condenser and evaporator fins, could cause product malfunction or inefficient operation.

➤ **Operational**

- **Do not expose the skin directly to cool air for long periods of time. (Do not sit in the draft).**

This could harm to your health.

- **Do not use the product for special purposes, such as preserving foods, works of art, etc.**

It is a consumer air conditioner, not a precision refrigerant system.

There is risk of damage or loss of property.

- **Do not block the inlet or outlet of air flow.**

It may cause product failure.

- **Use a soft cloth to clean. Do not use harsh detergents, solvents, etc.**

There is risk of fire, electric shock, or damage to the plastic parts of the product.

- **Do not touch the metal parts of the product when removing the air filter. They are very sharp.**

There is risk of personal injury.

- **Do not step on or put anything on the product. (outdoor units)**

There is risk of personal injury and failure of product.

- **Always insert the filter securely. Clean the filter every two weeks or more often if necessary.**

A dirty filter reduces the efficiency of the air conditioner and could cause product malfunction or

damage.

- **Do not insert hands or other object through air inlet or outlet while the product is operated.**

There are sharp and moving parts that could cause personal injury.

- **Do not drink the water drained from the product.**

It is not sanitary could cause serious health issues.

- **Use a firm stool or ladder when cleaning or maintaining the product.**

Be careful and avoid personal injury.

- **Replace the all batteries in the remote control with new ones of the same type. Do not mix old and new batteries or different types of batteries.**

There is risk of fire or explosion.

- **Do not recharge or disassemble the batteries. Do not dispose of batteries in a fire.**

They may burn or explode.

- **If the liquid from the batteries gets onto your skin or clothes, wash it well with clean water. Do not use the remote if the batteries have leaked.**

The chemical in batteries could cause burns or other health hazards

2. Function

Model Names of Indoor/Outdoor Units

	Capacity	Model	Indoor units	Outdoor units
DC Inverter	9K	MS9A-09HRDN1-MP0W	MS9A-09HRDN1-MP0W	MOC-09HDN1-MP0W
		MS9A-09CRDN1-BS0W	MS9A-09CRDN1-BS0W	MOC-09CFN1-BS0W
		MS9A-09HRDN1-BS0W	MS9A-09HRDN1-BS0W	MOC-09HRFN1-BS0W
		MS9A-09HRDN1-BQ0W	MS9A-09HRDN1-BQ0W	MOC-09HFN1-BQ0W
	12K	MS9A-12HRDN1-MP0W	MS9A-12HRDN1-MP0W	MOC-12HDN1-MP0W
		MS9A-12CRDN1-BS0W	MS9A-12CRDN1-BS0W	MOC-12CFN1-BS0W
		MS9A-12CRDN1-MS0W	MS9A-12CRDN1-MS0W	MOC-12CRDN1-MS0W
		MS9A-12HRDN1-BS0W	MS9A-12HRDN1-BS0W	MOC-12HRFN1-BS0W
		MS9A-12HRDN1-MS0W	MS9A-12HRDN1-MS0W	MOC-12HRFN1-MS0W
		MS9A-12HRDN1-BS0W(B)	MS9A-12HRDN1-BS0W(B)	MOC-12HFN1-BS0W
	18K	MS9A-18HRDN1-MP0W	MS9A-18HRDN1-MP0W	MOF-18HDN1-MP0W
		MS9A-18CRDN1-MS0W	MS9A-18CRDN1-MS0W	MOF-18CRFN1-MS0W
		MS9A-18HRDN1-MS0W	MS9A-18HRDN1-MS0W	MOF-18HRFN1-MS0W
	24K	MS9A-24HRDN1-MP0W	MS9A-24HRDN1-MP0W	MOG-24HDN1-MP0W
		MS9A-24HRDN1-MP0W	MS9A-24HRDN1-MP0W	MOF-24HDN1-MP0W
		MS9A-24HRDN1-MS0W	MS9A-24HRDN1-MS0W	MOG-24HDN1-MS0W
MS9A-24CRDN1-MP0W		MOF-24CDN1-MP0W	MOF-24CDN1-MP0W	

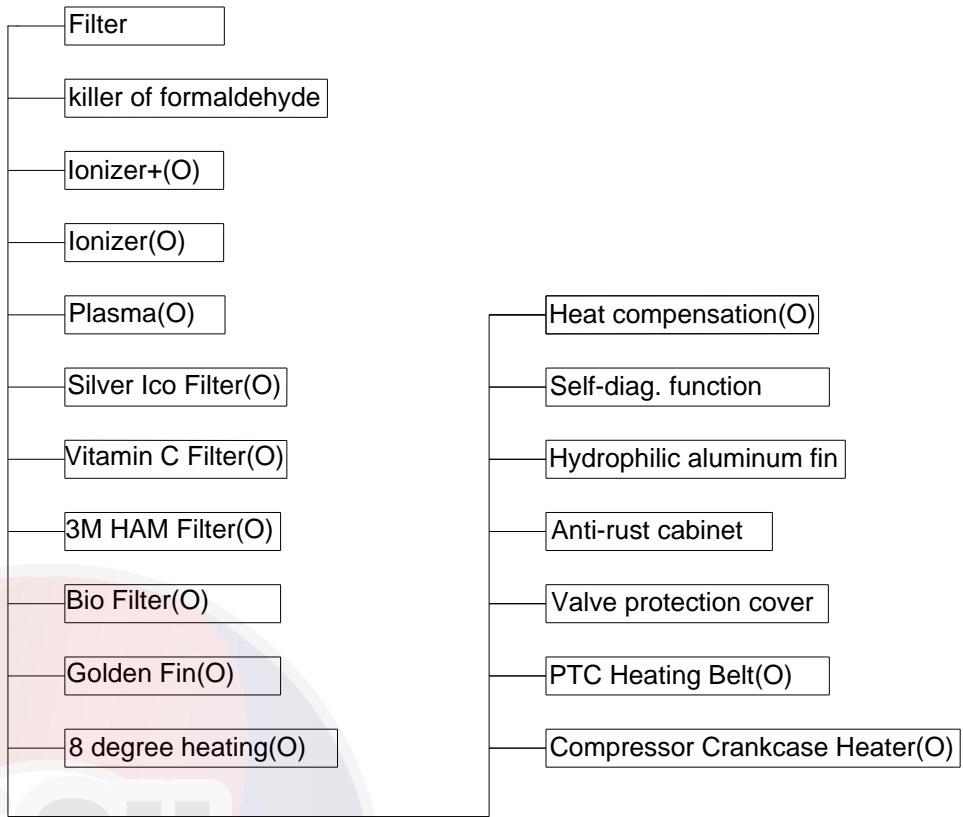

O: optional function

Climaproyectos.com

3. Dimension

3.1 Indoor Units

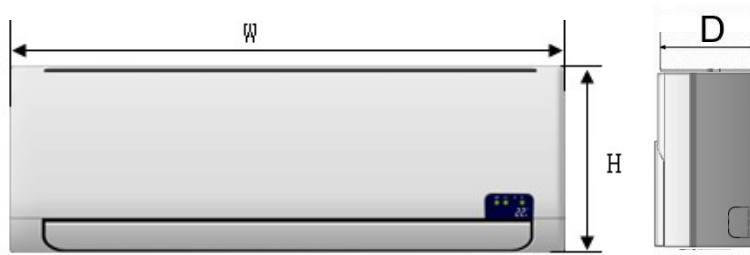

Model	W(mm)	H(mm)	D(mm)
MS9A-09HRDN1-MP0W	790	265	198
MS9A-09HRDN1-BQ0W	(31.10in)	(10.43in)	(7.80in)
MS9A-09CRDN1-BS0W	920 (36.22in)	292 (11.50in)	223 (8.78in)
MS9A-09HRDN1-BS0W			
MS9A-12HRDN1-MP0W			
MS9A-12CRDN1-BS0W			
MS9A-12HRDN1-BS0W			
MS9A-12CRDN1-MS0W			
MS9A-12HRDN1-MS0W			
MS9A-12HRDN1-BS0W(B)			
MS9A-18HRDN1-MP0W	998 (39.29in)	322 (12.68in)	240 (9.45in)
MS9A-18CRDN1-MS0W			
MS9A-18HRDN1-MS0W			
MS9A-24HRDN1-MP0W			
MS9A-24CRDN1-MP0W			
MS9A-24HRDN1-MS0W	1450 (57.09in)	340 (13.39in)	265 (10.43in)

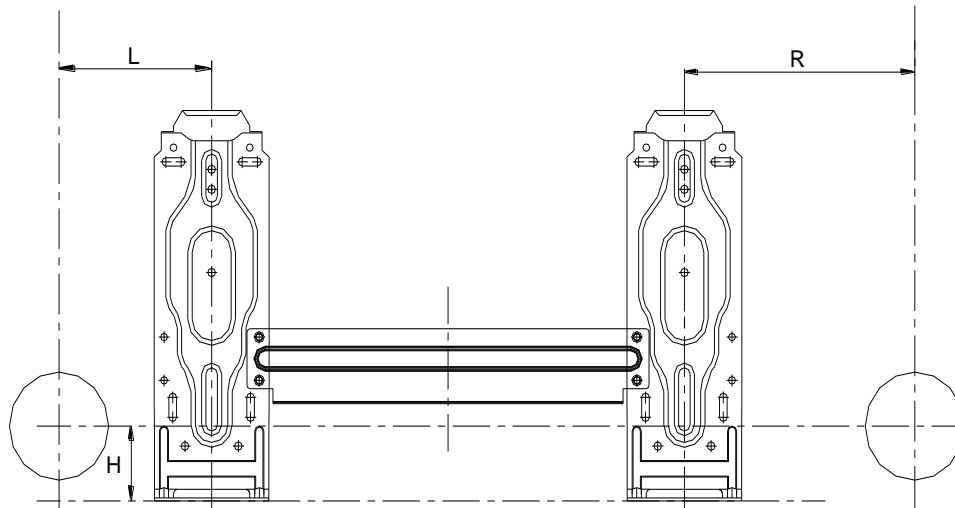

Model	L(mm)	R(mm)	H(mm)	Dimension of installation hole(mm)
MS9A-09HRDN1-MP0W	100	151	45	Φ65
MS9A-09HRDN1-BQ0W				

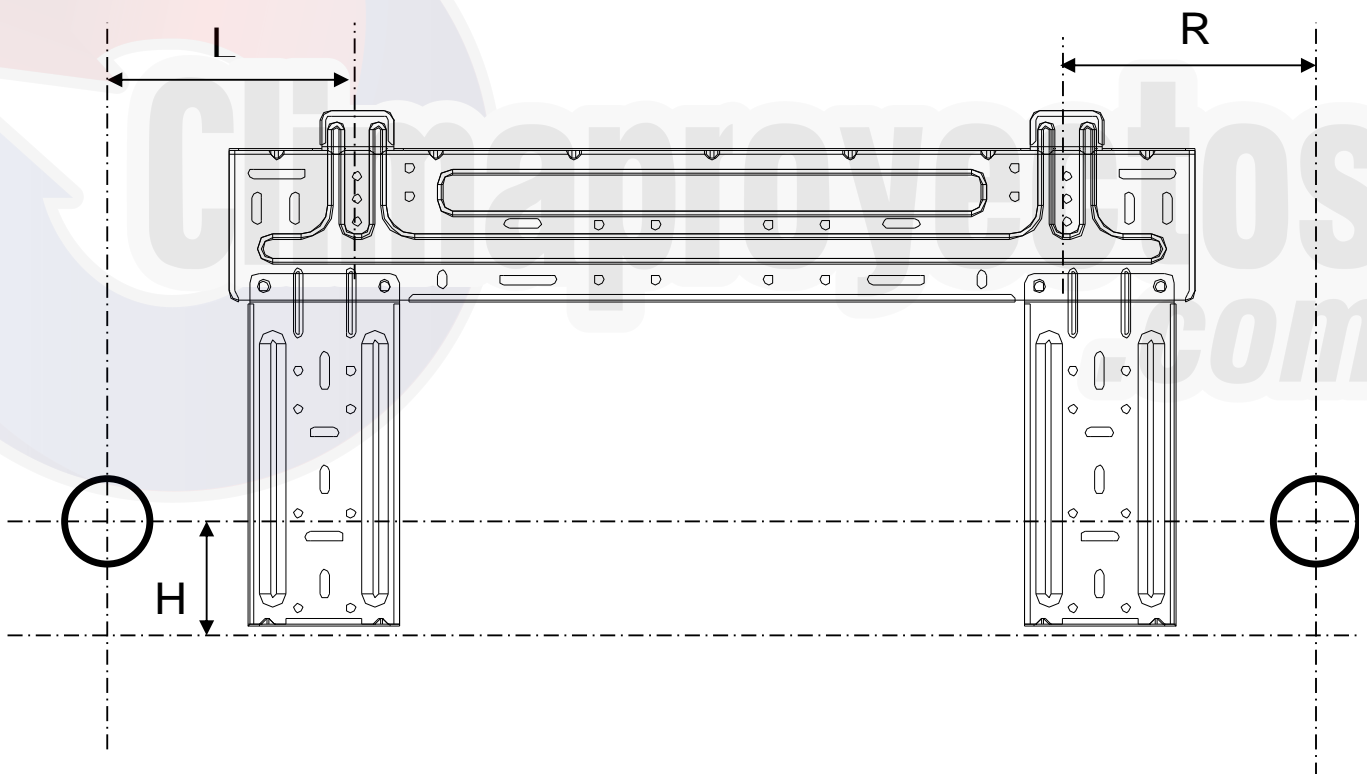

Model	L(mm)	R(mm)	H(mm)	Dimension of installation hole(mm)
MS9A-09CRDN1-BS0W	150	187	45	Φ65
MS9A-09HRDN1-BS0W				
MS9A-12HRDN1-MP0W				
MS9A-12CRDN1-BS0W				
MS9A-12HRDN1-BS0W				

MS9A-12CRDN1-MS0W				
MS9A-12HRDN1-MS0W				
MS9A-12HRDN1-BS0W(B)				

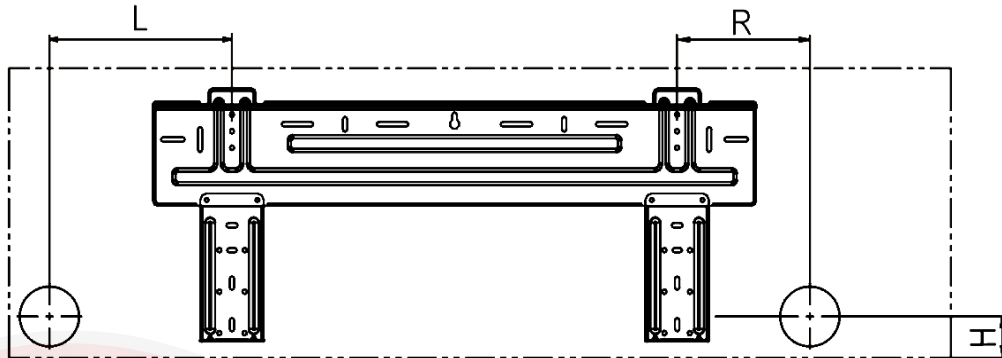

Model	L(mm)	R(mm)	H(mm)	Dimension of installation hole(mm)
MS9A-18HRDN1-MP0W	100	119	45	Φ65
MS9A-18CRDN1-MS0W				
MS9A-18HRDN1-MS0W				
MS9A-24HRDN1-MP0W				
MS9A-24CRDN1-MP0W				

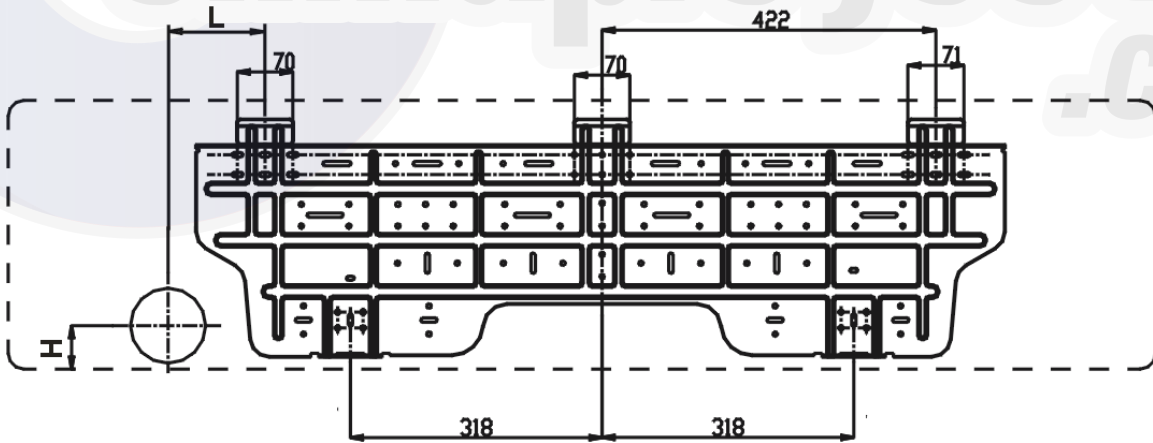

Model	L(mm)	H(mm)	Dimension of installation hole(mm)
MS9A-24HRDN1-MS0W	120.5	55	Φ95

3.2 Outdoor Units

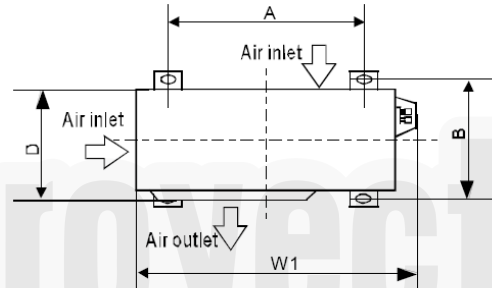
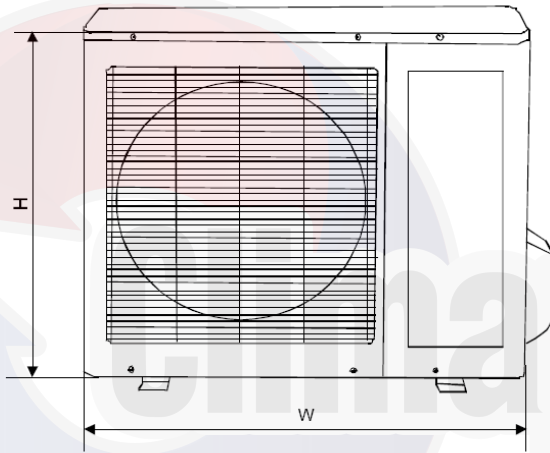
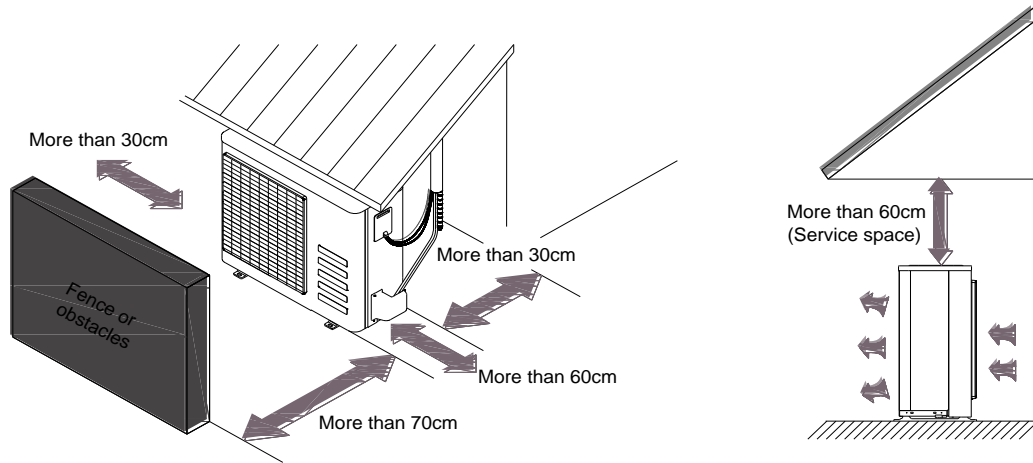

Model	W(mm)	D(mm)	H(mm)	W1(mm)	A(mm)	B(mm)
MOC-09HDN1-MP0W	760 (29.92in)	285 (11.22in)	590 (23.23in)	823 (32.40in)	530 (20.87in)	290 (11.42in)
MOC-09CFN1-BS0W						
MOC-09HRFN1-BS0W						
MOC-09HFN1-BQ0W						
MOC-12HDN1-MP0W						
MOC-12CFN1-BS0W						
MOC-12CRDN1-MS0W						
MOC-12HRFN1-BS0W						
MOC-12HRFN1-MS0W						
MOC-12HFN1-BS0W						
MOF-18HDN1-MP0W	845 (33.27in)	320 (12.60in)	700 (27.56in)	908 (35.75in)	560 (22.05in)	335 (13.19in)
MOF-18CRFN1-MS0W						
MOF-18HRFN1-MS0W						
MOF-24HDN1-MP0W						
MOF-24CDN1-MP0W	900 (35.43in)	315 (12.40in)	860 (33.86in)	980 (38.58in)	590 (23.23in)	333 (13.11in)
MOG-24HDN1-MS0W						

4. Refrigerant Cycle Diagram

For cooling only models:

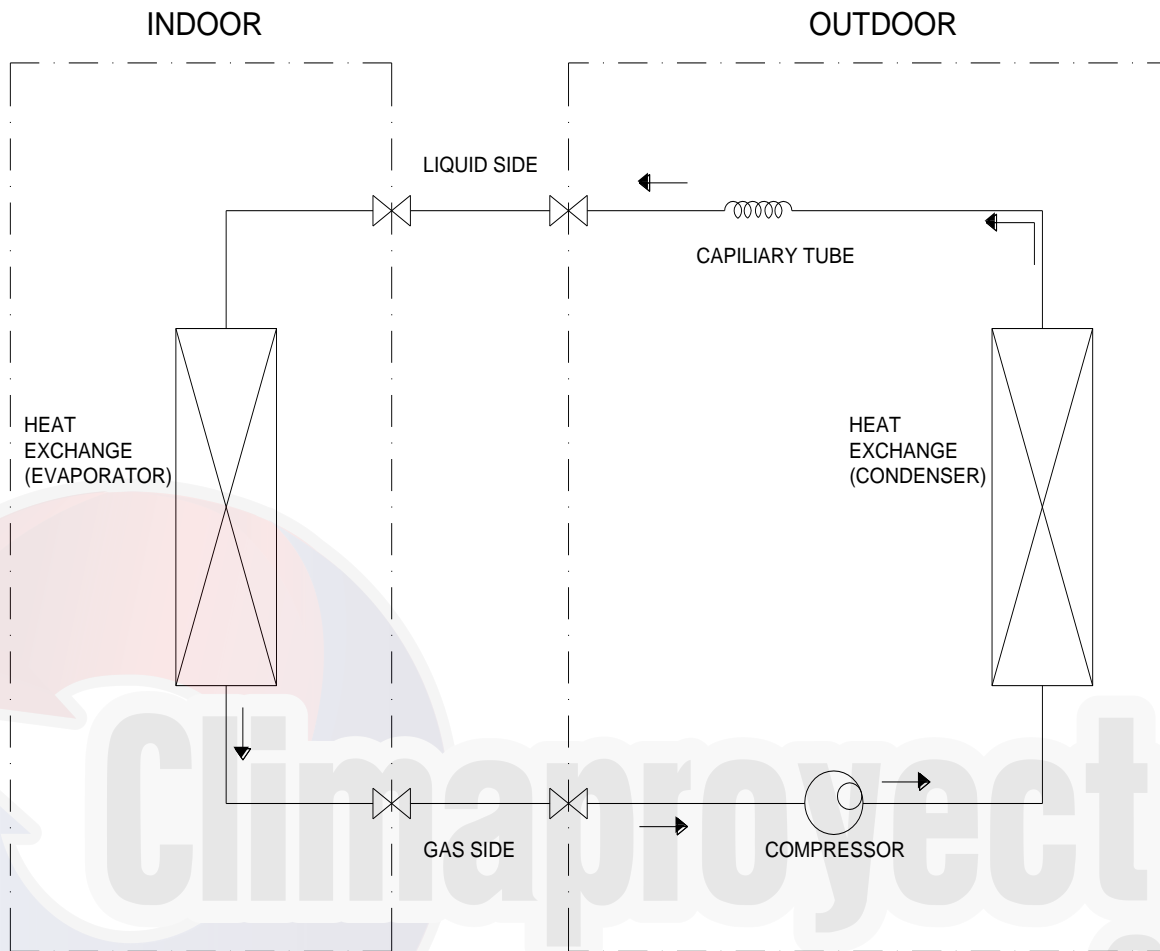

For heat pump models:

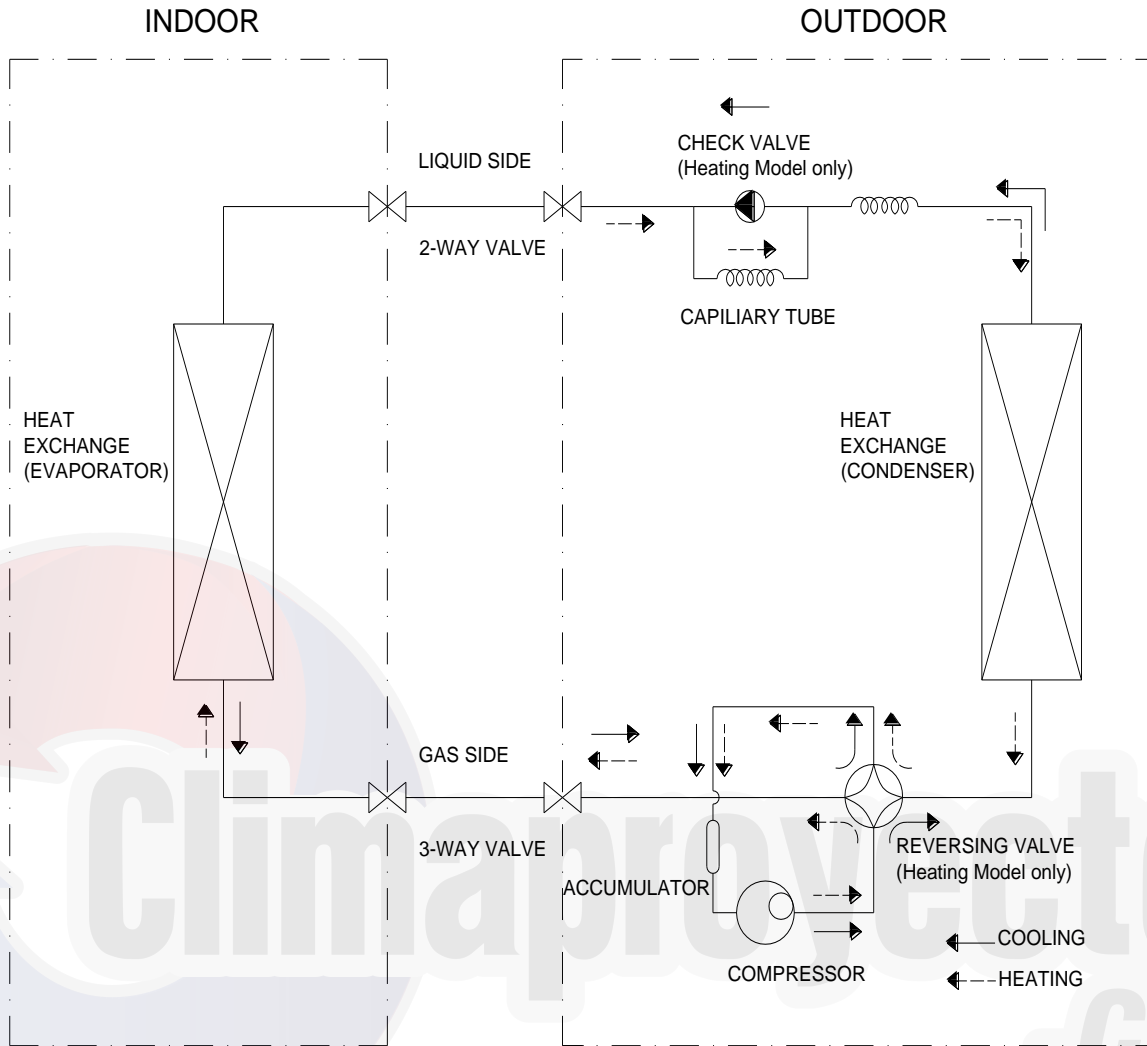

5. Wiring Diagram

5.1 Indoor Units

MS9A-09HRDN1-MP0W; MS9A-12HRDN1-MP0W; MS9A-12CRDN1-MS0W;

MS9A-12HRDN1-MS0W

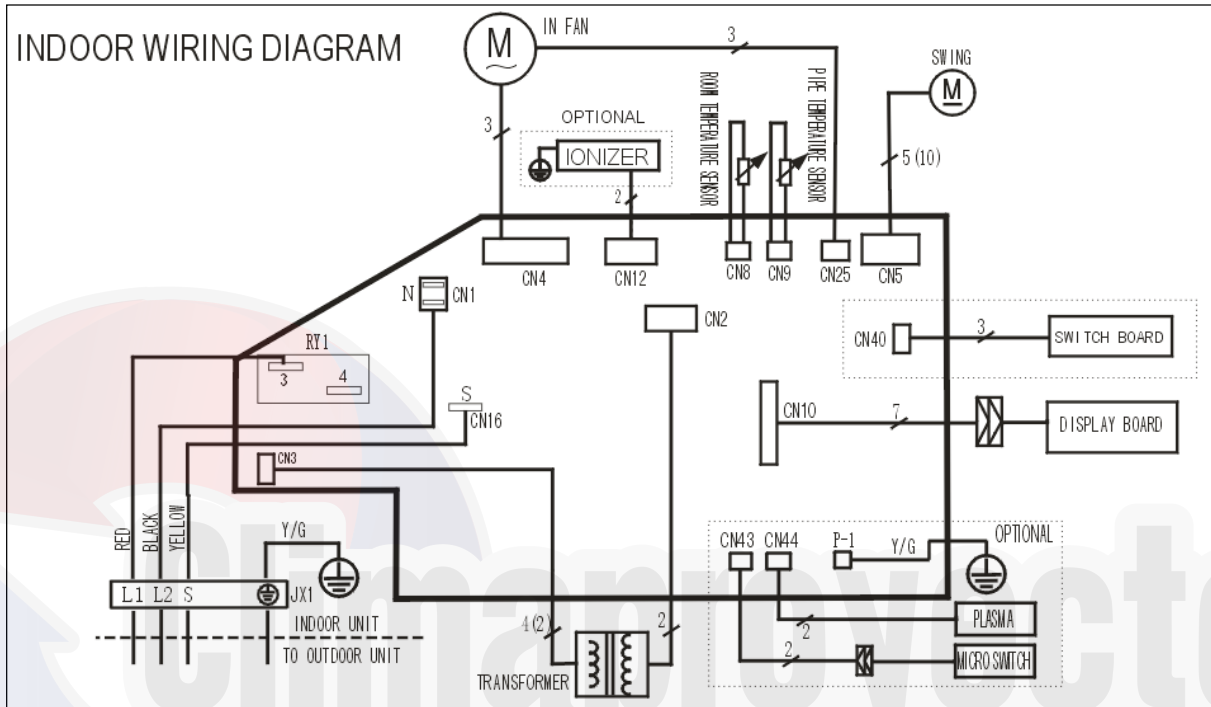

MS9A-09CRDN1-BS0W; MS9A-09HRDN1-BS0W; MS9A-12CRDN1-BS0W; MS9A-12HRDN1-BS0W

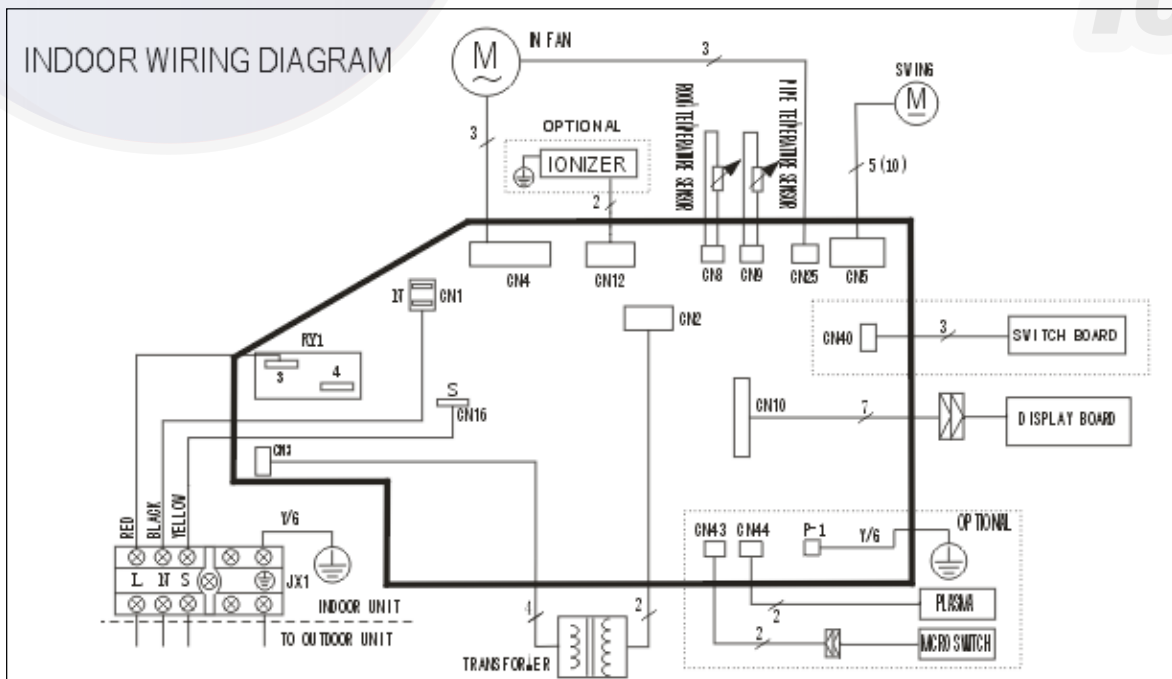

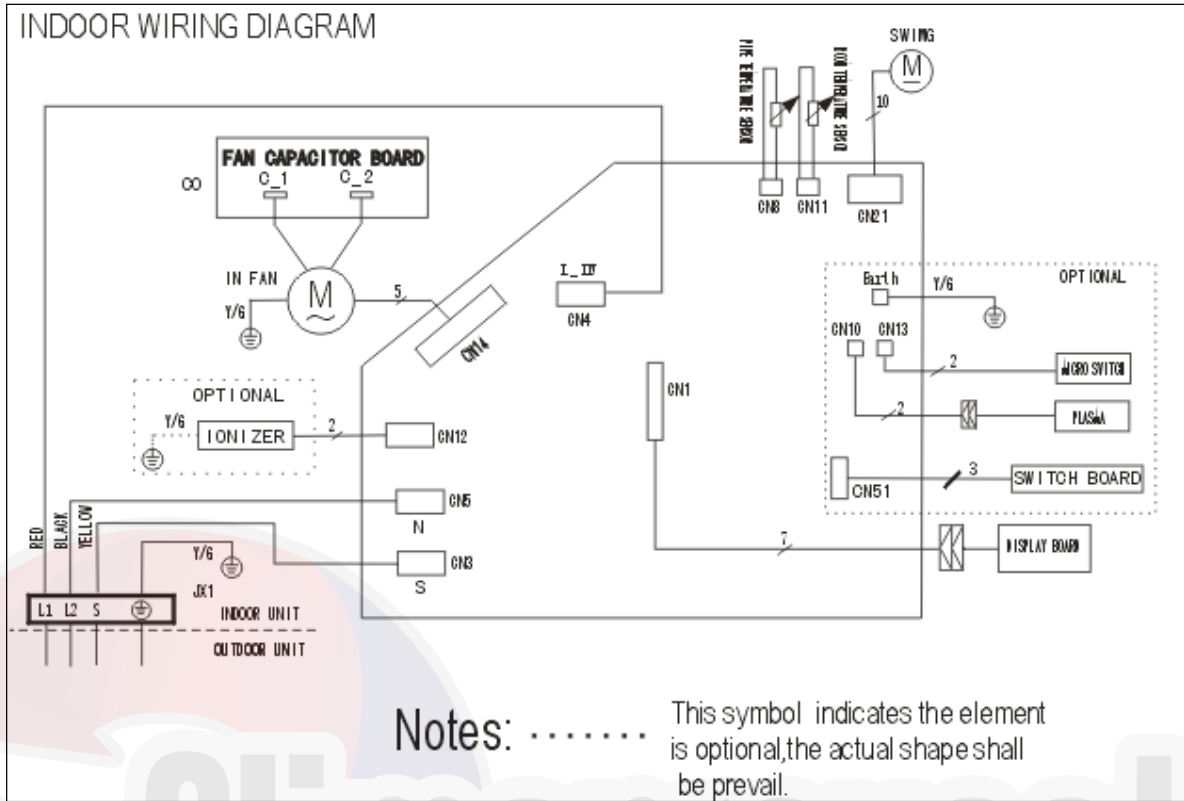

MS9A-09HRDN1-BQ0W

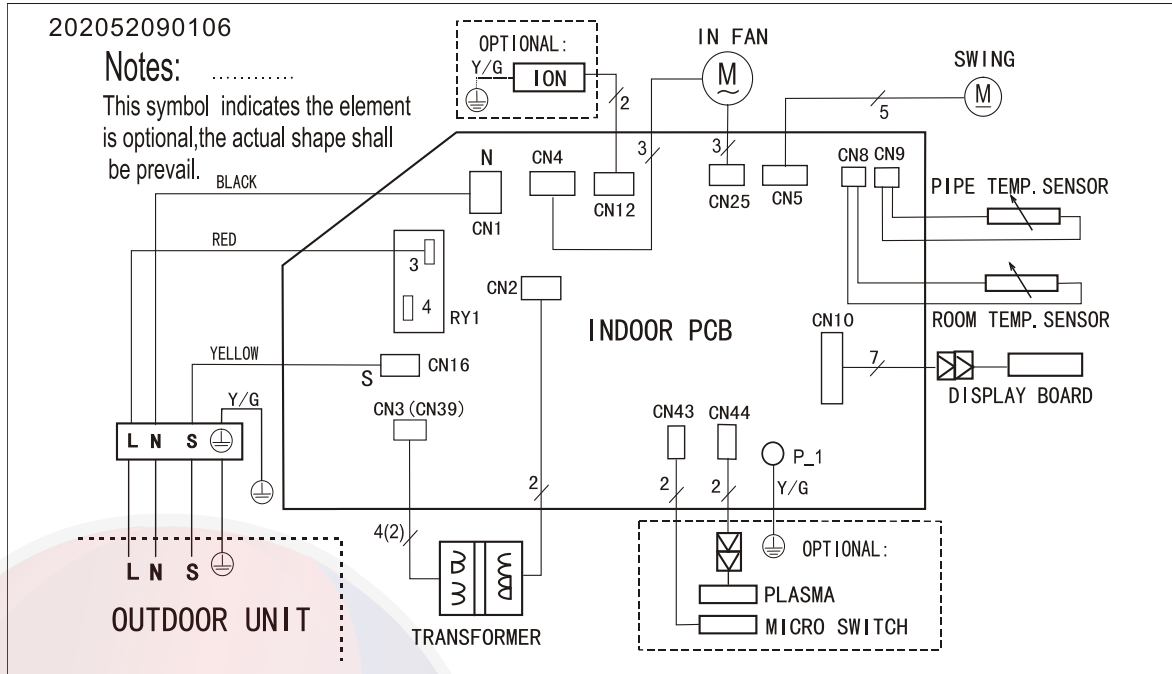

MS9A-12HRDN1-BS0W(B)

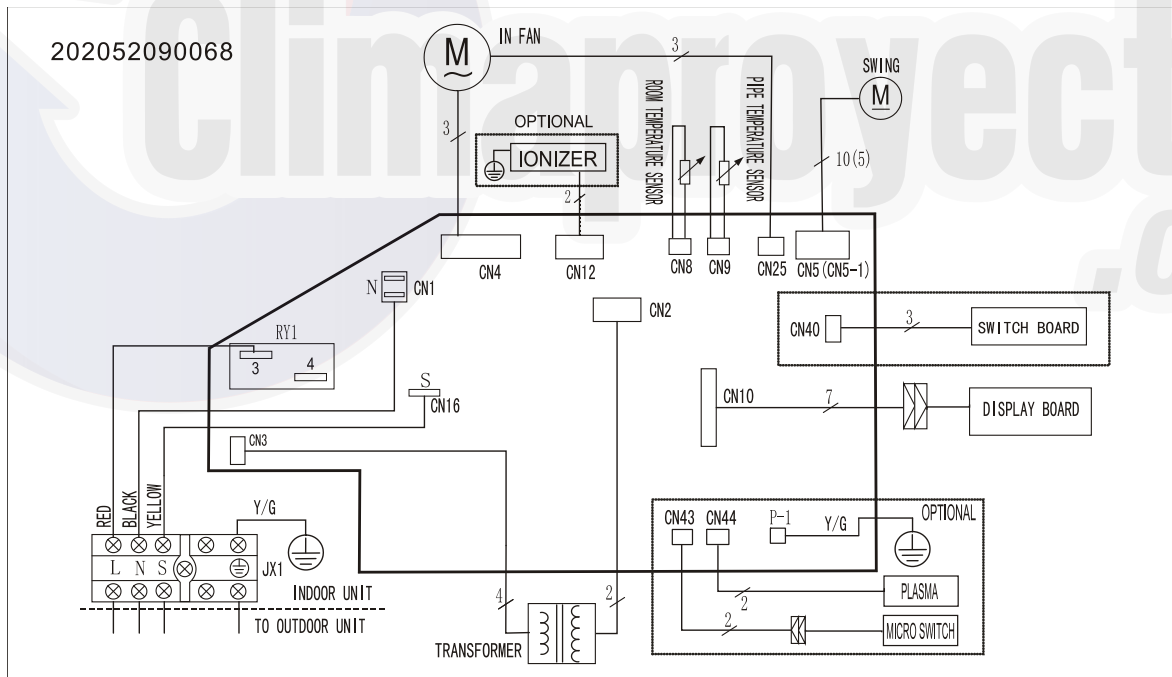

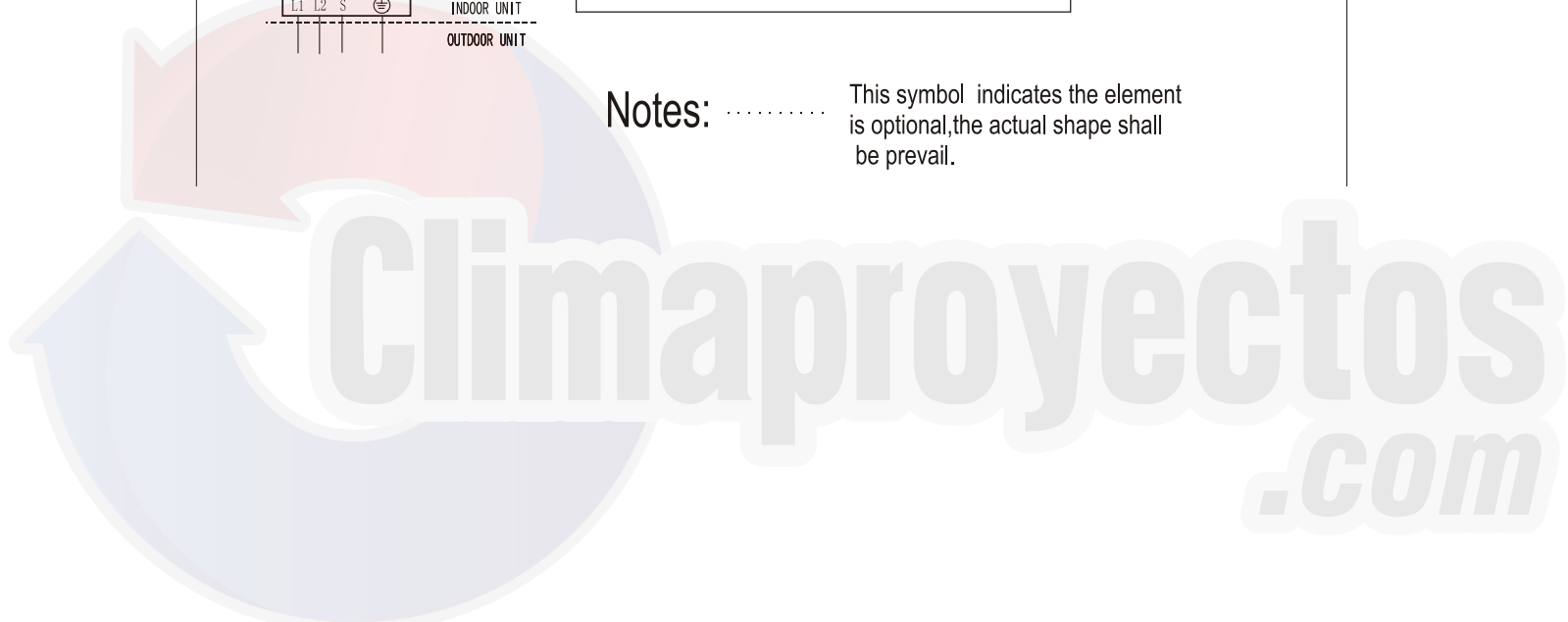
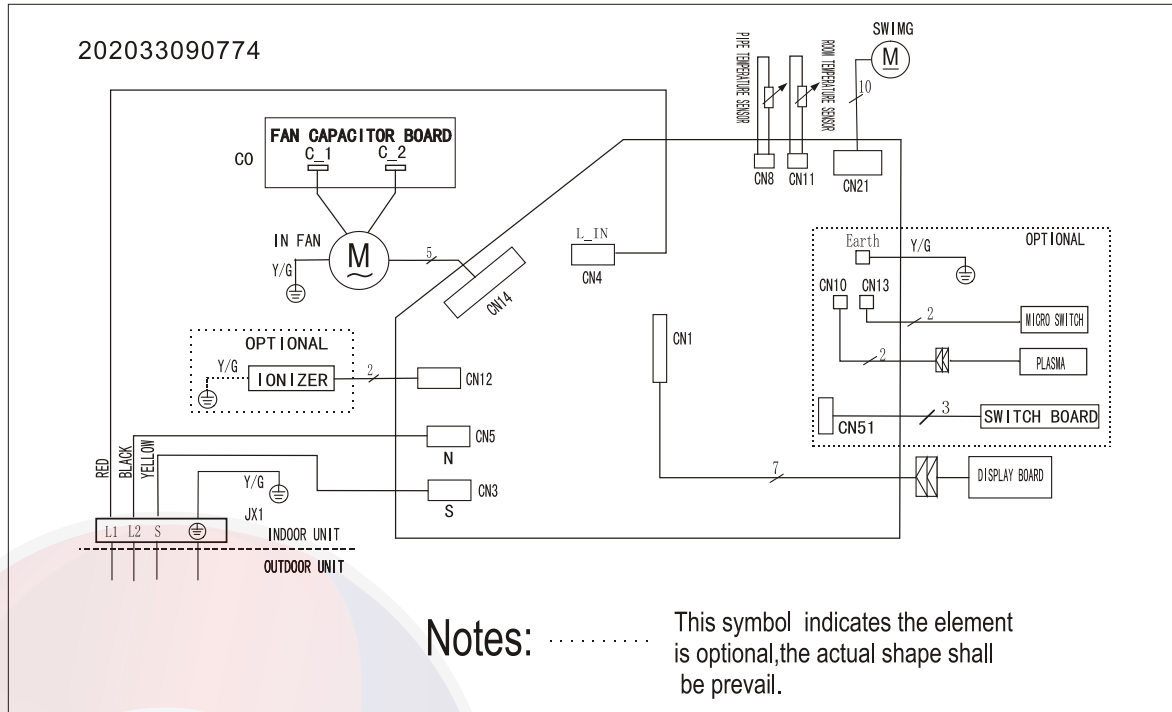

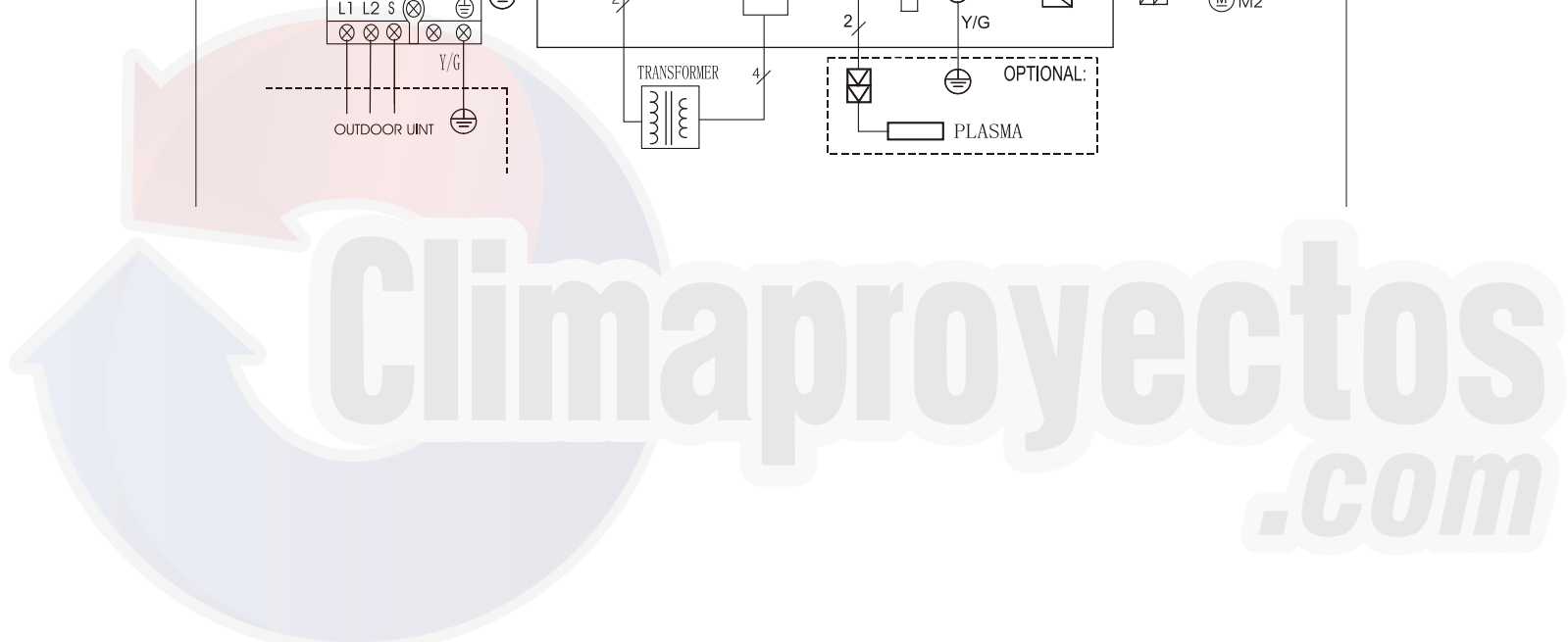
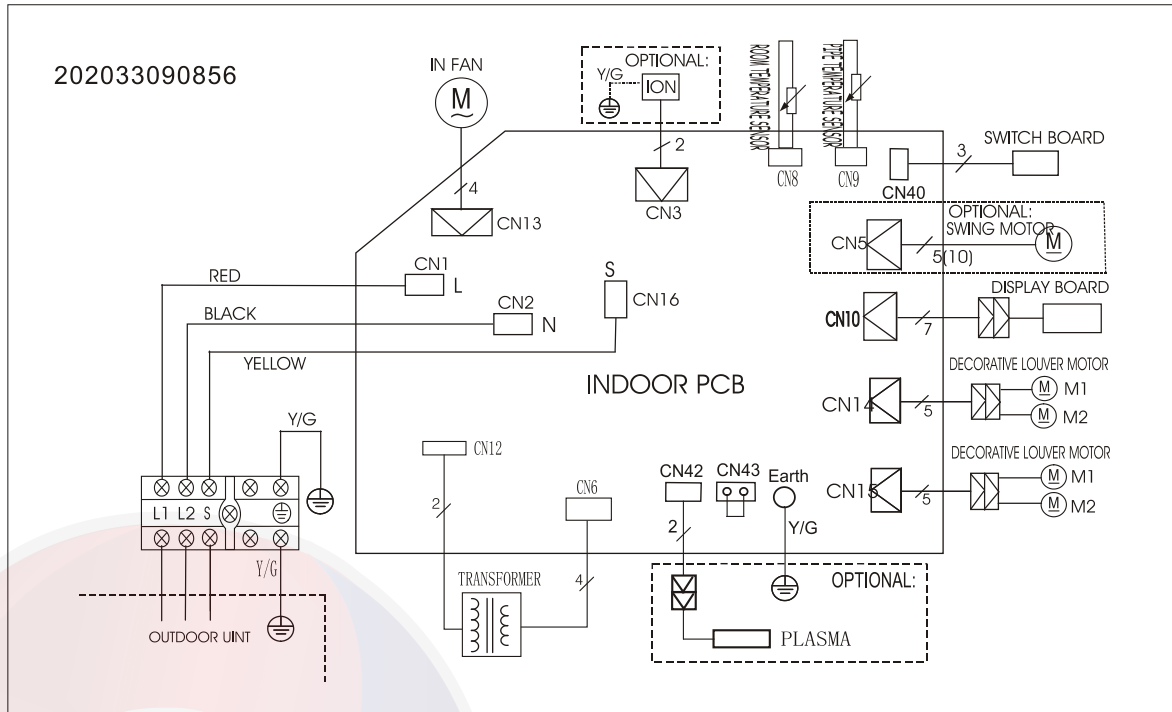

5.2 Outdoor Units

MOC-09HDN1-MP0W; MOC-12HDN1-MP0W

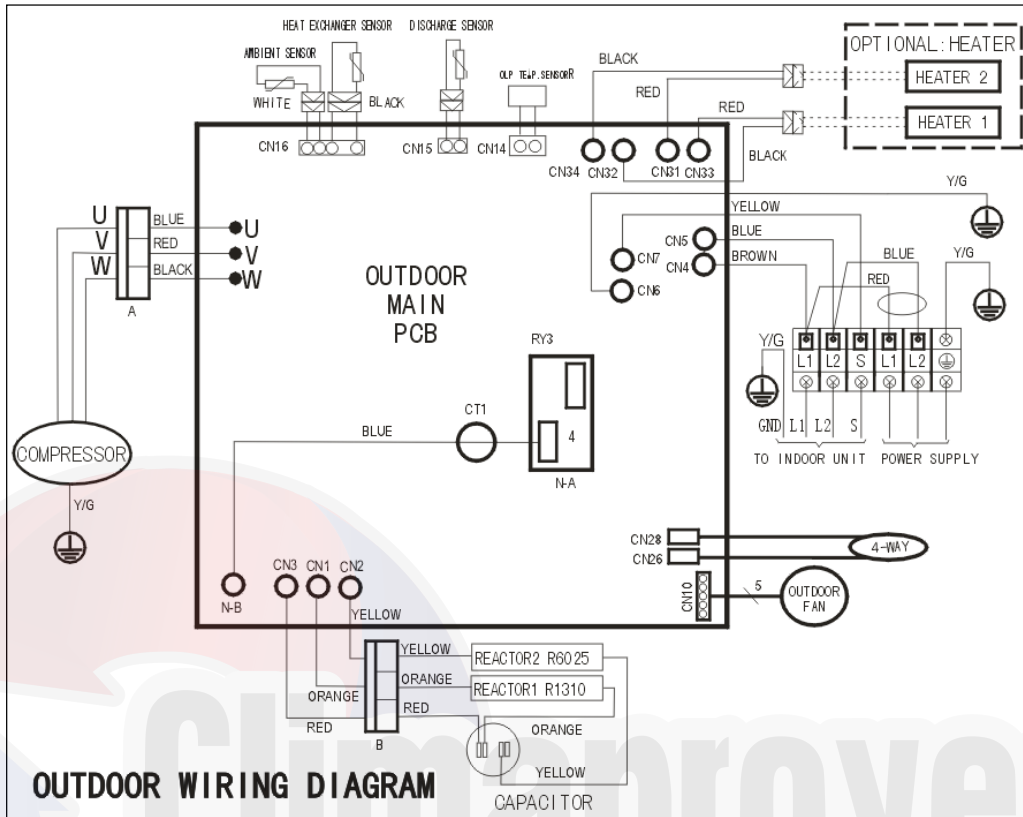

MOC-09CFN1-BS0W; MOC-09HRFN1-BS0W; MOC-12CFN1-BS0W; MOC-12HRFN1-BS0W

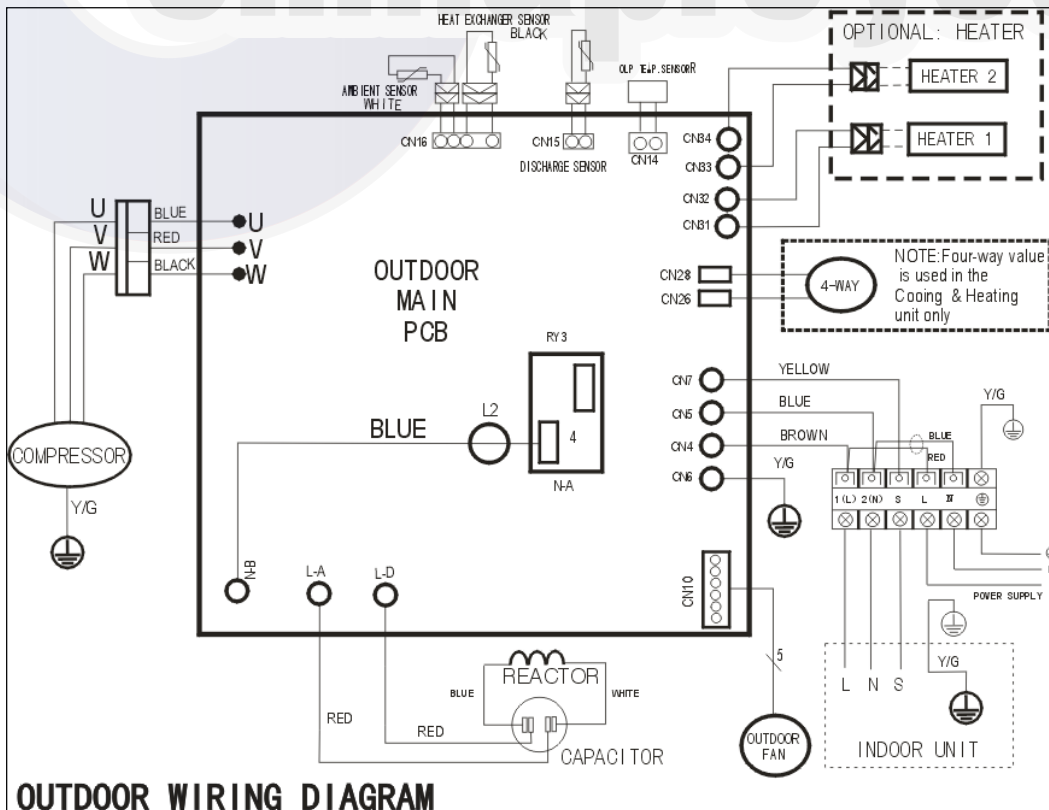

MOC-12CRDN1-MS0W

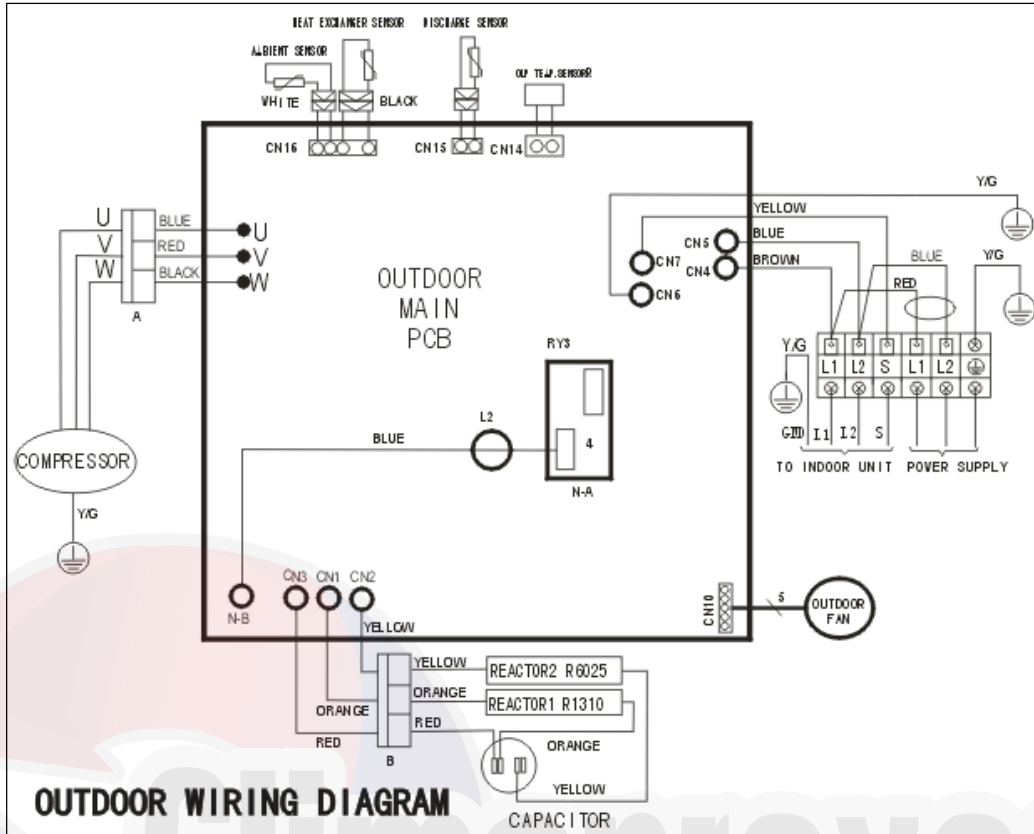

MOC-12HRFN1-MS0W

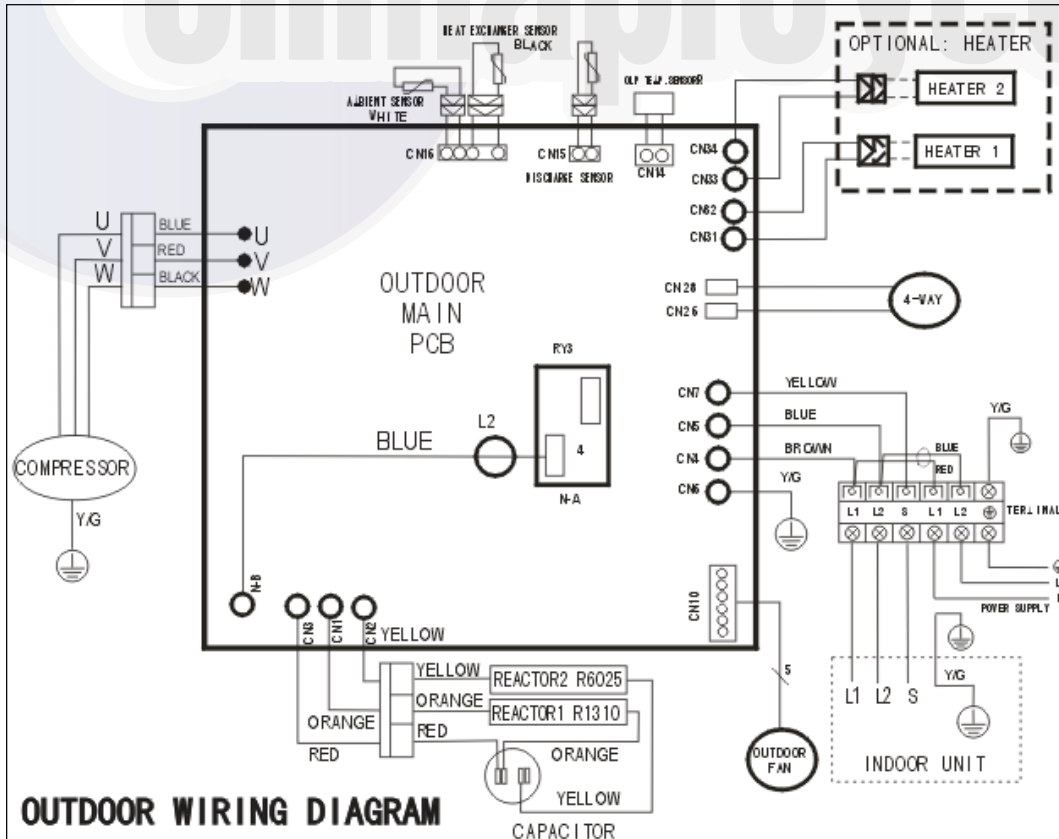

MOF-18HDN1-MP0W

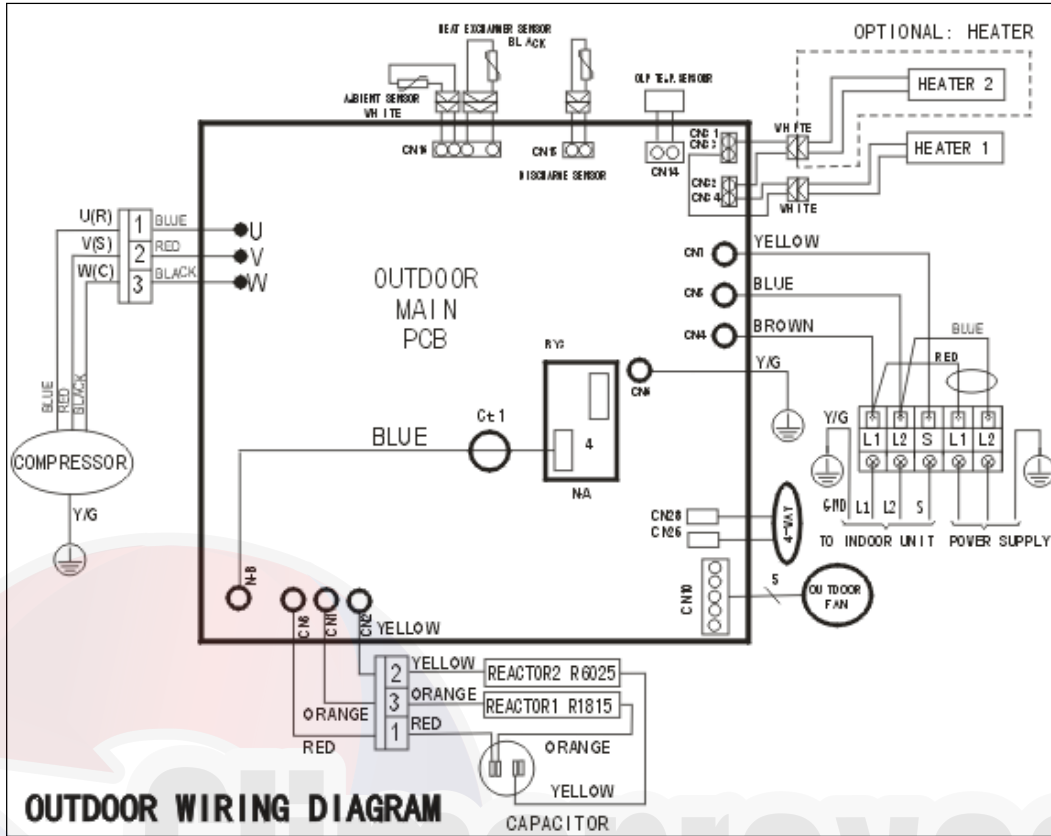

MOF-18CRFN1-MS0W

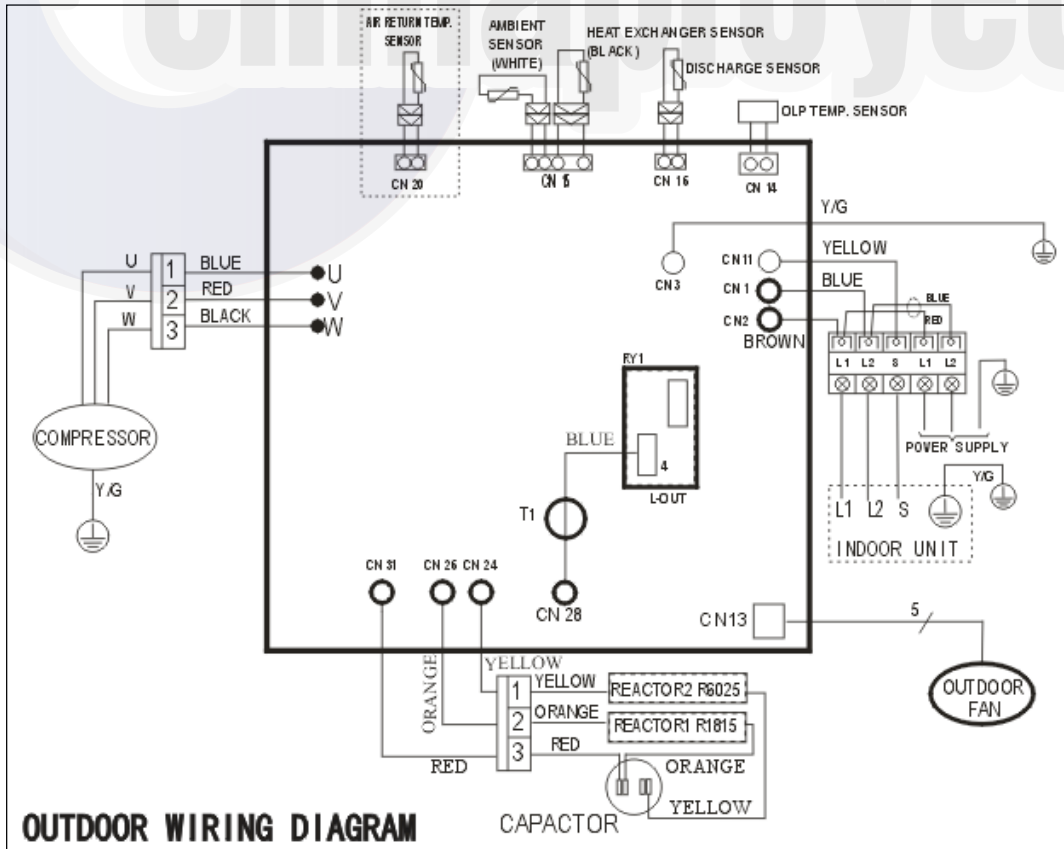

MOF-18HRFN1-MS0W

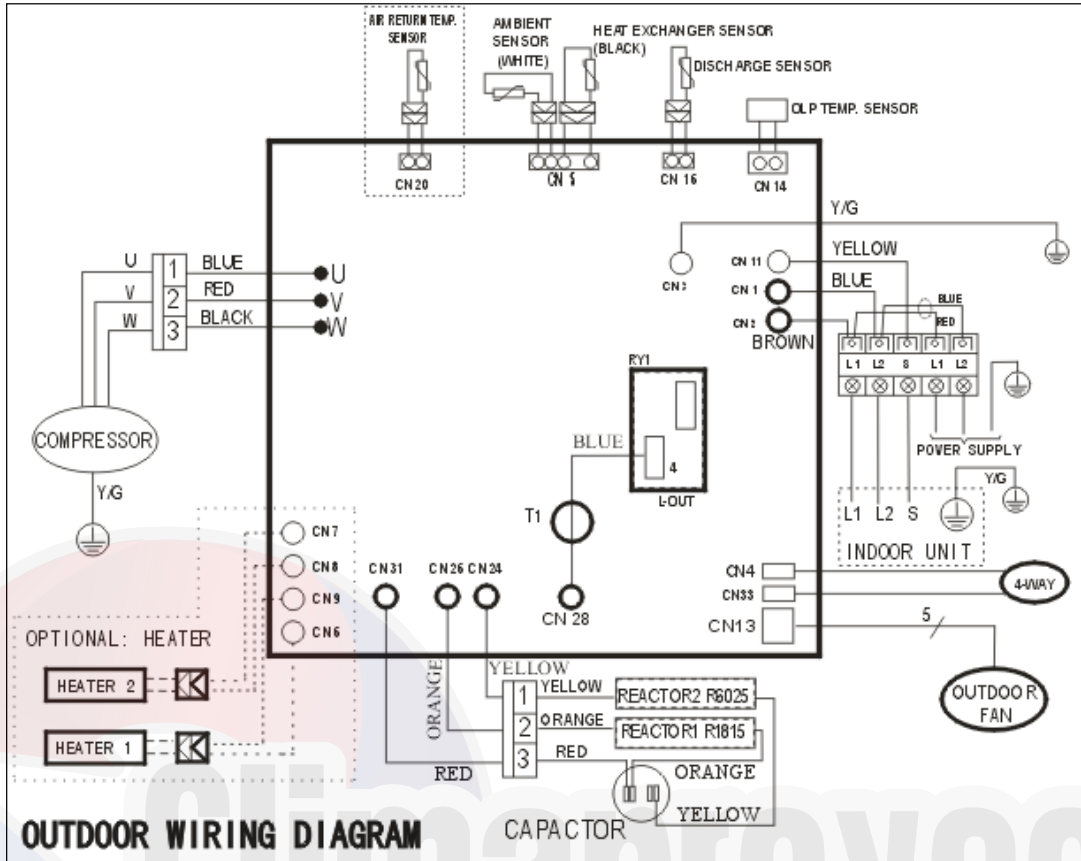

MOG-24HDN1-MP0W

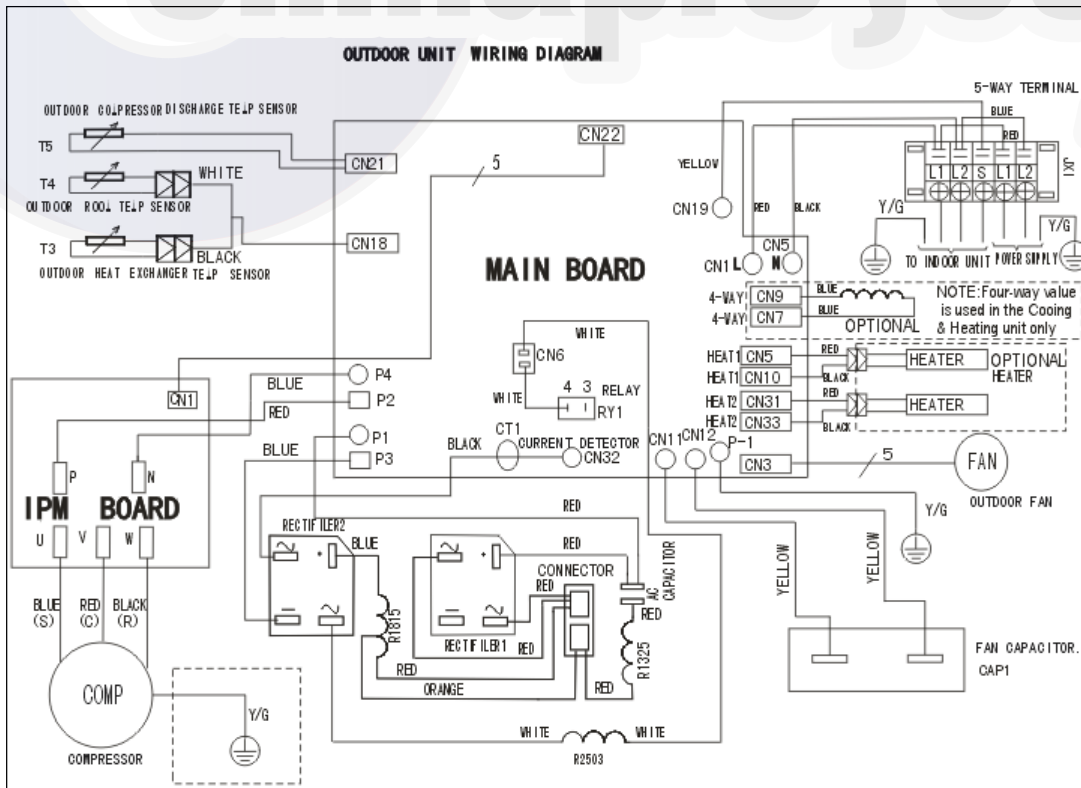

MOC-09HFN1-BQ0W, MOC-12HFN1-BS0W

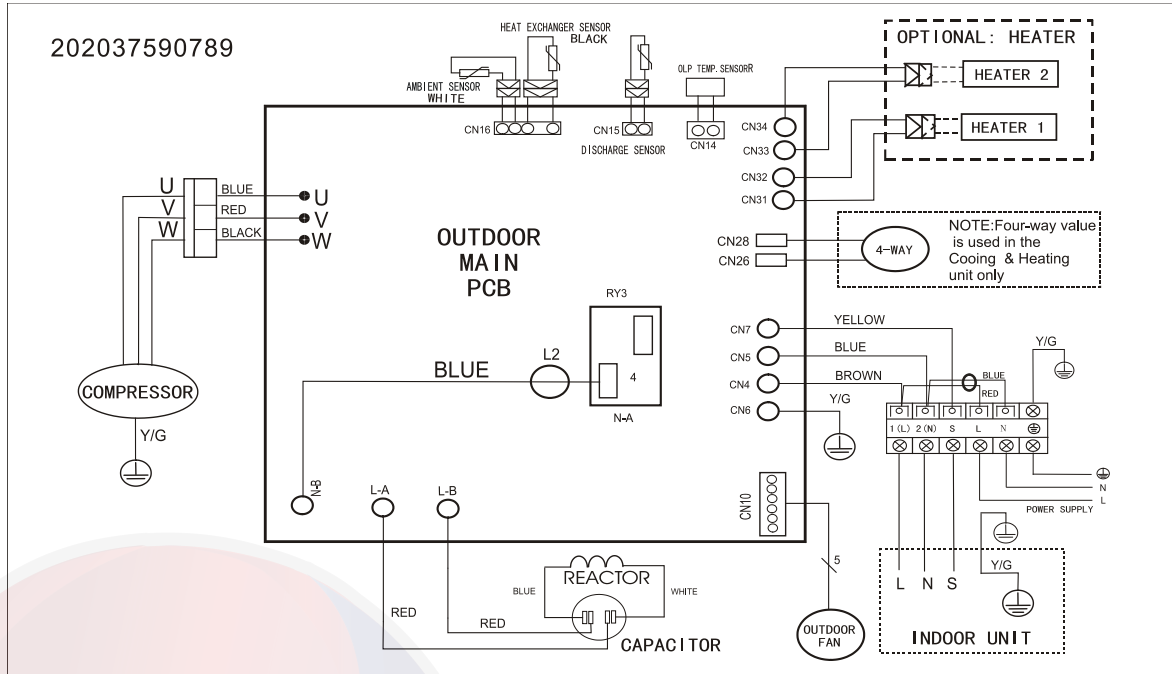

MOF-24HDN1-MP0W

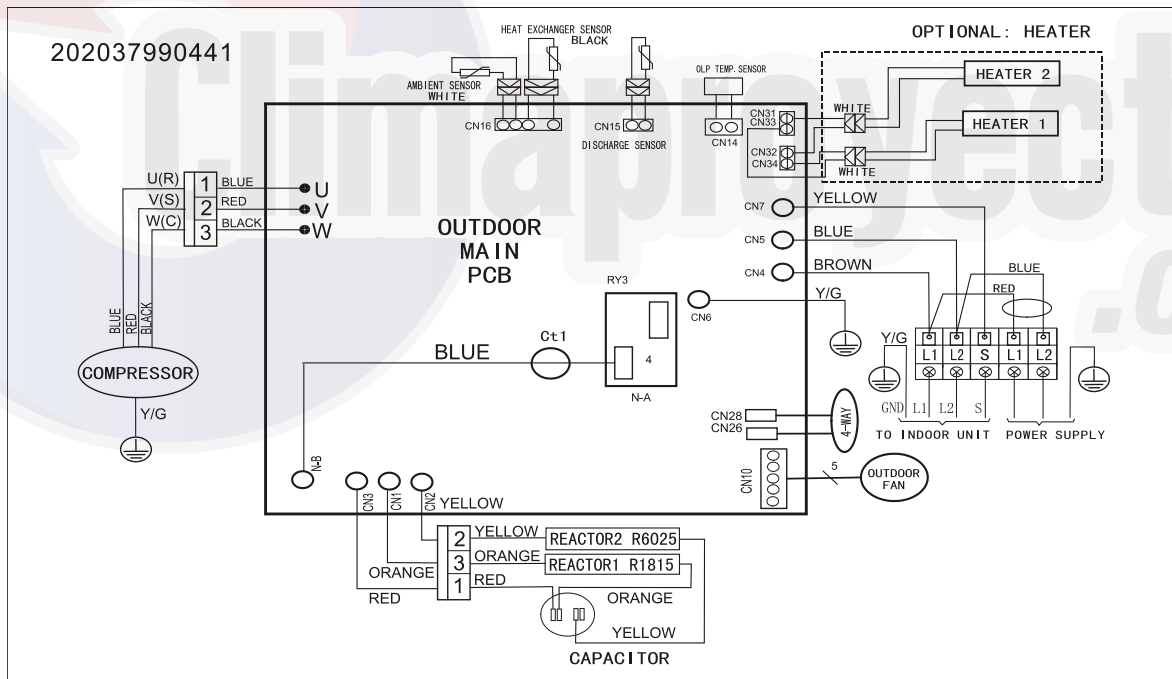

MOG-24HDN1-MS0W

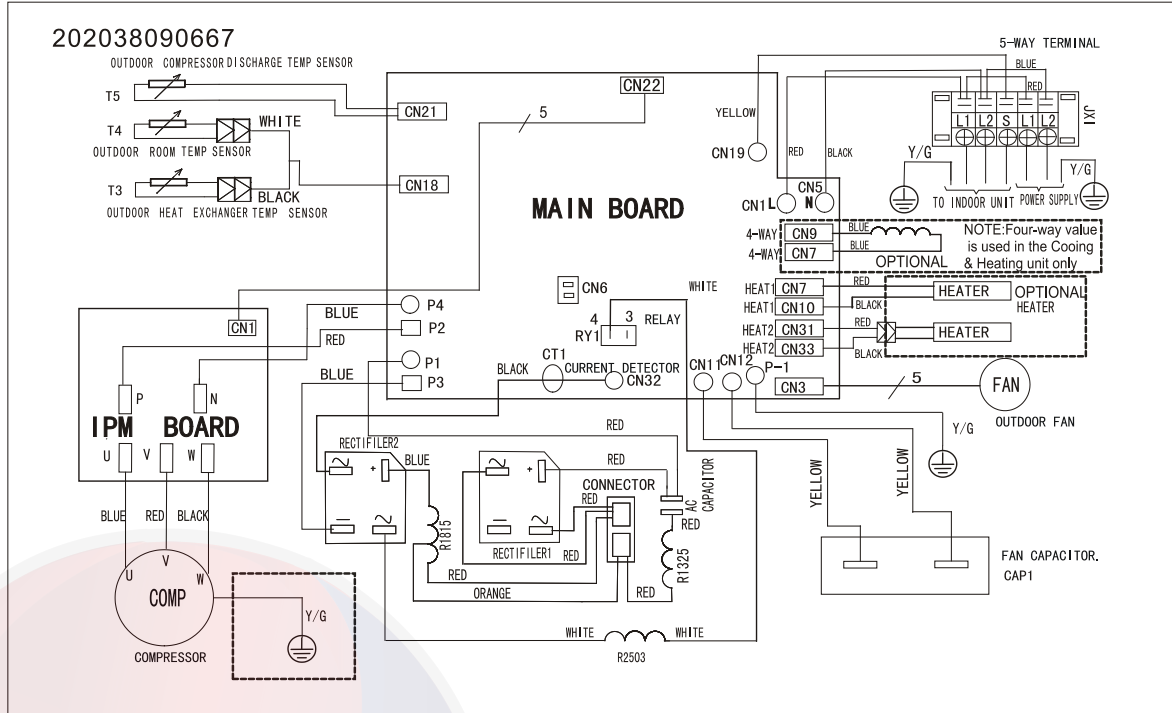

MOF-24CDN1-MP0W

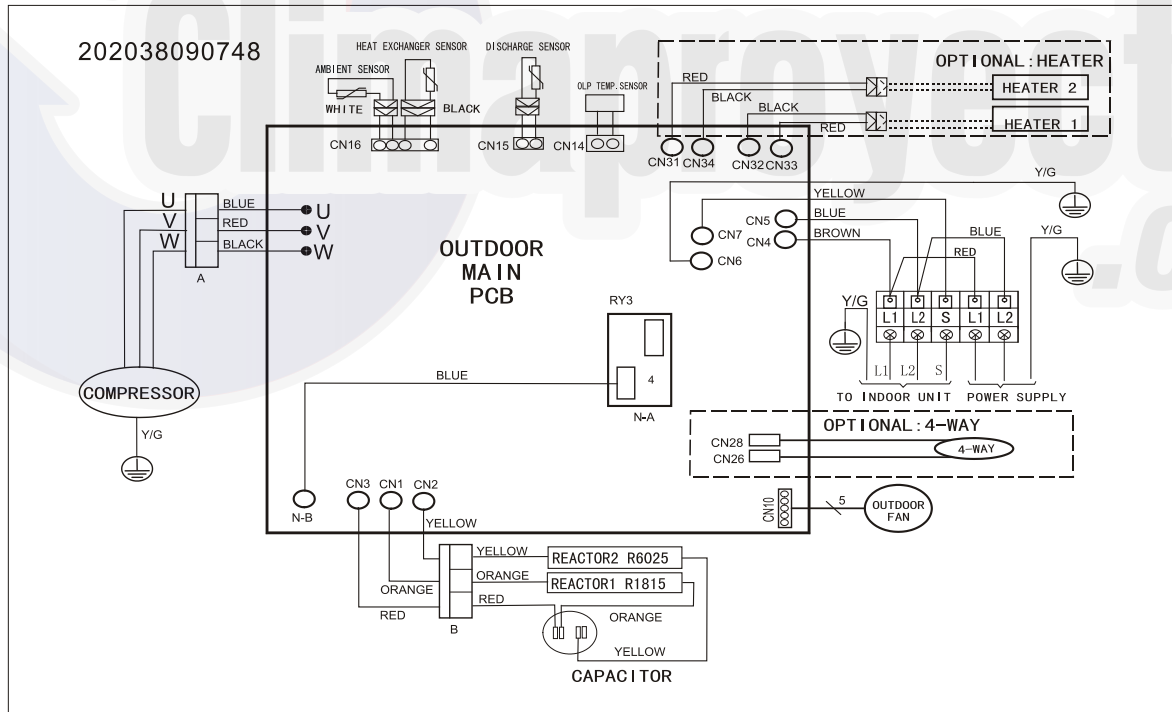

6. Installation details

6.1 Wrench torque sheet for installation

Outside diameter		Torque	Additional tightening torque
mm	inch	N.cm	N.cm
Φ6.35	1/4	1500(153kgf.cm)	1600(163kgf.cm)
Φ9.52	3/8	2500(255kgf.cm)	2600(265kgf.cm)
Φ12.7	1/2	3500(357kgf.cm)	3600(367kgf.cm)
Φ15.9	5/8	4500(459kgf.cm)	4700(479kgf.cm)
Φ19	3/4	6500(663kgf.cm)	6700(683kgf.cm)



6.2 Connecting the cables

The power cord of connect should be selected according to the following specifications sheet.

Appliance Amps	AWG Wire Size
10	18
13	16
18	14
25	12
30	10

The cable size and the current of the fuse or switch are determined by the maximum current indicated on the nameplate which located on the side panel of the unit. Please refer to the nameplate before selecting the cable, fuse and switch.



6.3 Pipe length and the elevation

The pipe length and refrigerant amount:

Model	Connective pipe length	Air purging method	Additional amount of refrigerant to be charged
All	Less than 5m	Use vacuum pump	-----
9k/12k	More than 5m	Use vacuum pump	(Pipe length – 5) × 20g/m
18k/24k	More than 5m	Use vacuum pump	(Pipe length – 5) × 40g/m

Model	Standard length (m)	Max. Elevation B (m)	Max. Length A (m)
9k/12k	5	8	20
18k/24k	5	10	25

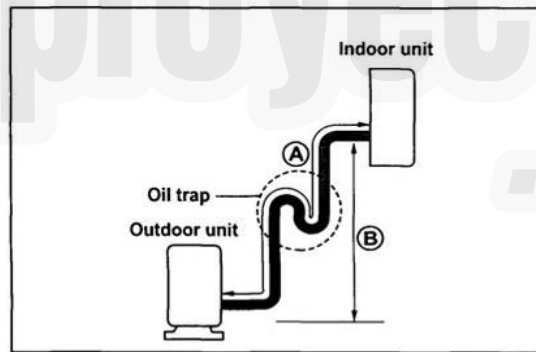
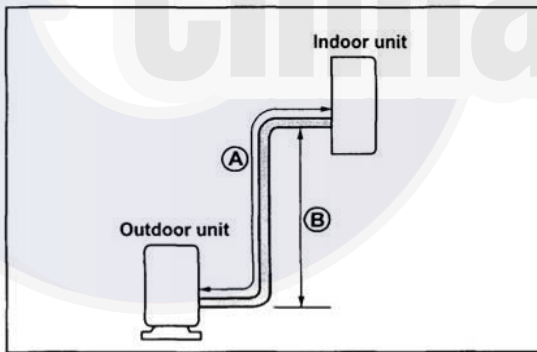

Caution:

The capacity test is based on the standard length and the maximum permissible length is based on the system reliability.

The oil trap should be installed per 5-7 meters.

6.4 Installation for the first time

Air and moisture in the refrigerant system have undesirable effects as below:

- Pressure in the system rises.
- Operating current rises.
- Cooling or heating efficiency drops.
- Moisture in the refrigerant circuit may freeze and block capillary tubing.
- Water may lead to corrosion of parts in the refrigerant system.

Therefore, the indoor units and the pipes between indoor and outdoor units must be leak tested and evacuated to remove gas and moisture from the system.

Gas leak check (Soap water method):

Apply soap water or a liquid neutral detergent on the indoor unit connections or outdoor unit connections by a soft brush to check for leakage of the connecting points of the piping. If bubbles come out, the pipes have leakage.

1. Air purging with vacuum pump

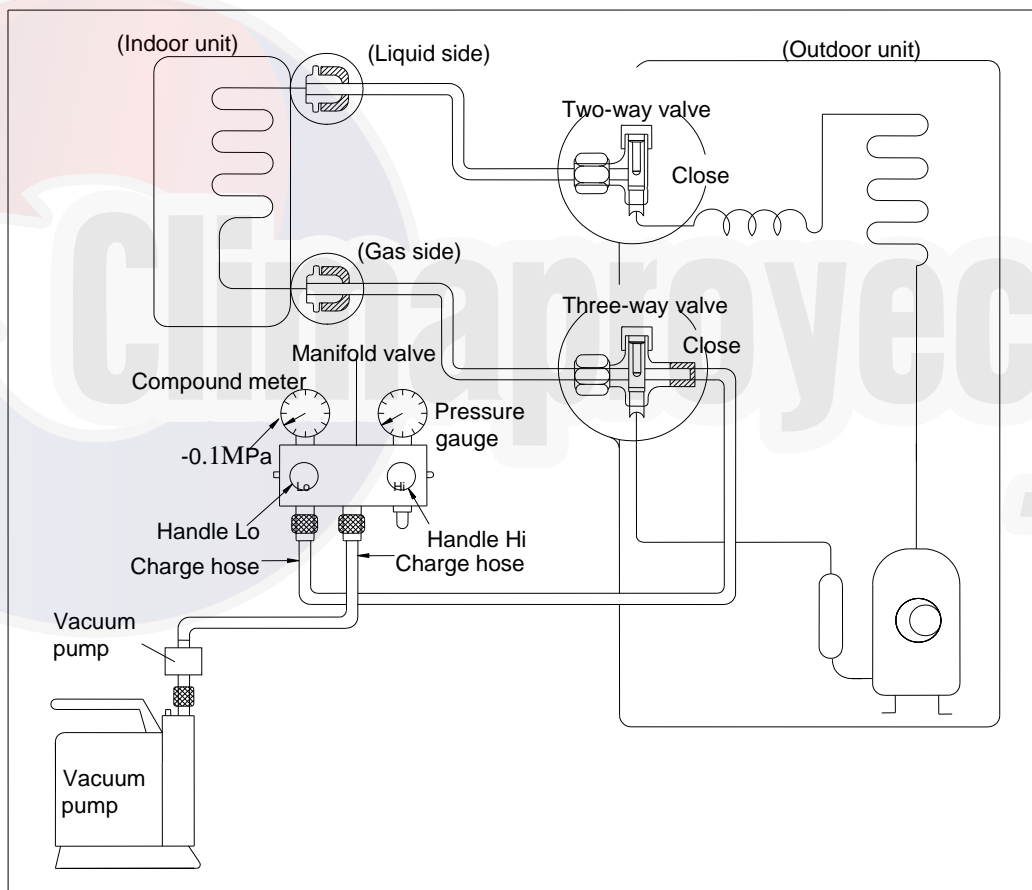

- 1) Completely tighten the flare nuts of the indoor and outdoor units, confirm that both the 2-way and 3-way valves are set to the closed position.
- 2) Connect the charge hose with the push pin of handle lo to the 3-way valves gas service port..
- 3) Connect the charge hose of handle hi connection to the vacuum pump.
- 4) Fully open the handle Lo of the manifold valve.
- 5) Operate the vacuum pump to evacuate.
- 6) Make evacuation for 30 minutes and check whether the compound meter indicates -0.1Mpa. If

the meter does not indicate -0.1Mpa after pumping 30 minutes, it should be pumped 20 minutes more. If the pressure can't achieve -0.1Mpa after pumping 50 minutes, please check if there are some leakage points.

Fully close the handle Lo valve of the manifold valve and stop the operation of the vacuum pump. Confirm that the gauge needle does not move (approximately 5 minutes after turning off the vacuum pump).

7) Turn the flare nut of the 3-way valves about 45° counterclockwise for 6 or 7seconds after the gas coming out, then tighten the flare nut again. Make sure the pressure display in the pressure indicator is a little higher than the atmosphere pressure. Then remove the charge hose from the 3 way valve.

8) Fully open the 2 way valve and 3 way valve and securely tighten the cap of the 3 way valve.

2. Air purging by refrigerant

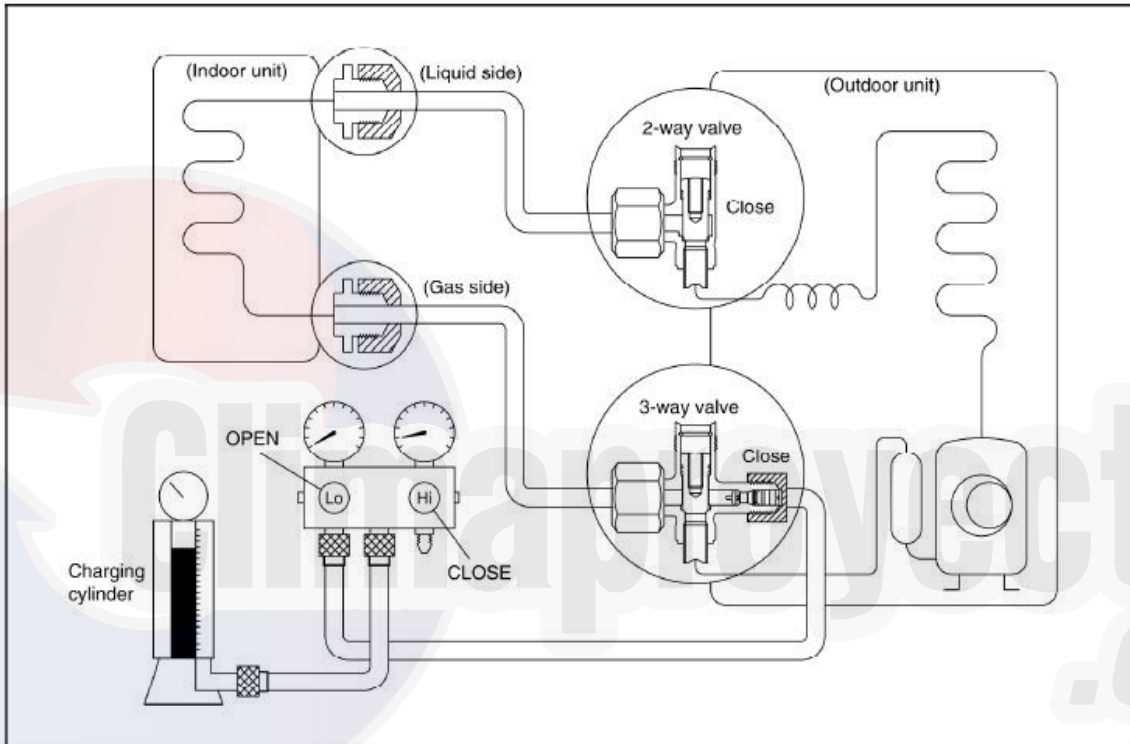

Procedure:

- 1). Confirm that both the 2-way and 3-way valves are set to the closed position.
- 2). Connect the charge set and a charging cylinder to the service port of the 3-way valve.
- 3). Air purging.

Open the valves on the charging cylinder and the charge set. Purge the air by loosening the flare nut on the 2-way valve approximately 45' for 3 seconds then closing it for 1 minute; repeat 3 times.

After purging the air, use a torque wrench to tighten the flare nut on the 2-way valve.

- 4). Check the gas leakage.

Check the flare connections for gas leakage.

- 5). Discharge the refrigerant.

Close the valve on the charging cylinder and discharge the refrigerant by loosening the flare nut on the 2-way valve approximately 45' until the gauge indicates 0.3 to 0.5 Mpa.

6). Disconnect the charge set and the charging cylinder, and set the 2-way and 3-way valves to the open position.

Be sure to use a hexagonal wrench to operate the valve stems.

7). Mount the valve stems nuts and the service port cap.

Be sure to use a torque wrench to tighten the service port cap to a torque 18N·m.

Be sure to check the gas leakage.

3. Adding the refrigerant if the pipe length >5m

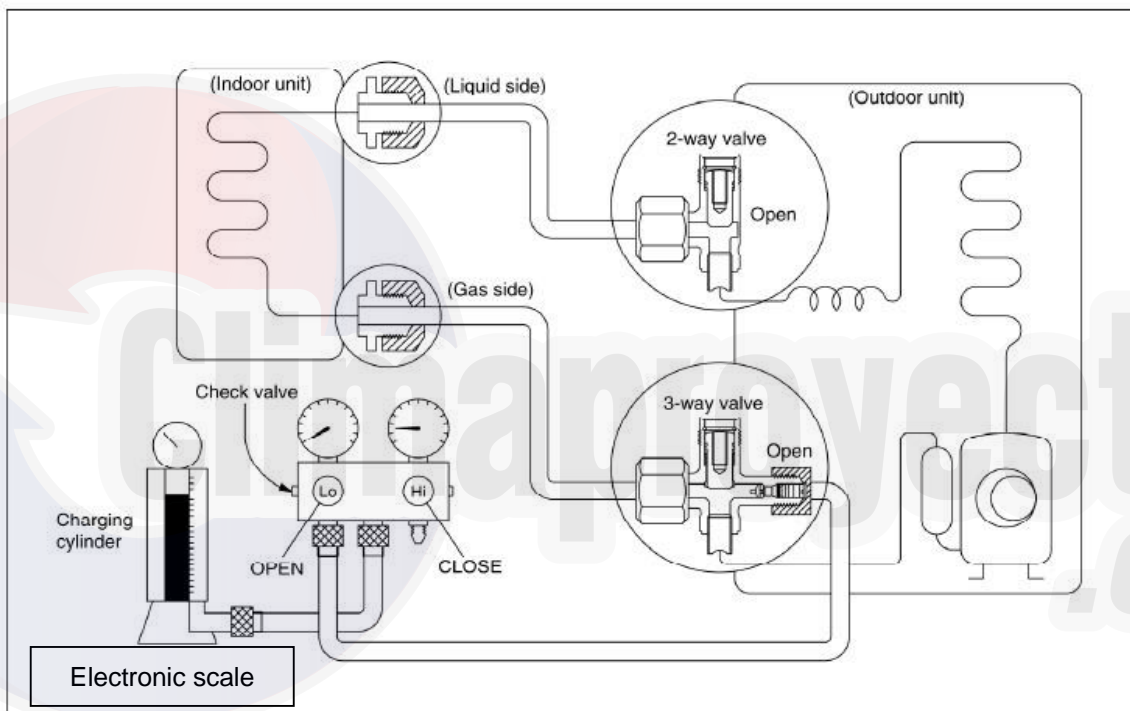

Procedure:

1). Connect the charge hose to the charging cylinder, open the 2-way valve and the 3-way valve.

Connect the charge hose which you disconnected from the vacuum pump to the valve at the bottom of the cylinder. If the refrigerant is R410A, make the cylinder bottom up to ensure the liquid charge.

2). Purge the air from the charge hose.

Open the valve at the bottom of the cylinder and press the check valve on the charge set to purge the air (be careful of the liquid refrigerant).

3) Put the charging cylinder onto the electronic scale and record the weight.

4) Operate the air conditioner at the cooling mode.

5) Open the valves (Low side) on the charge set and charge the system with liquid refrigerant.

6). When the electronic scale displays the proper weight (refer to the table), disconnect the charge hose from the 3-way valve's service port immediately and turn off the air conditioner before disconnecting the hose.

7). Mount the valve stem caps and the service port

Use torque wrench to tighten the service port cap to a torque of 18N.m.

Be sure to check for gas leakage.

6.5 Adding the refrigerant after running the system for many years

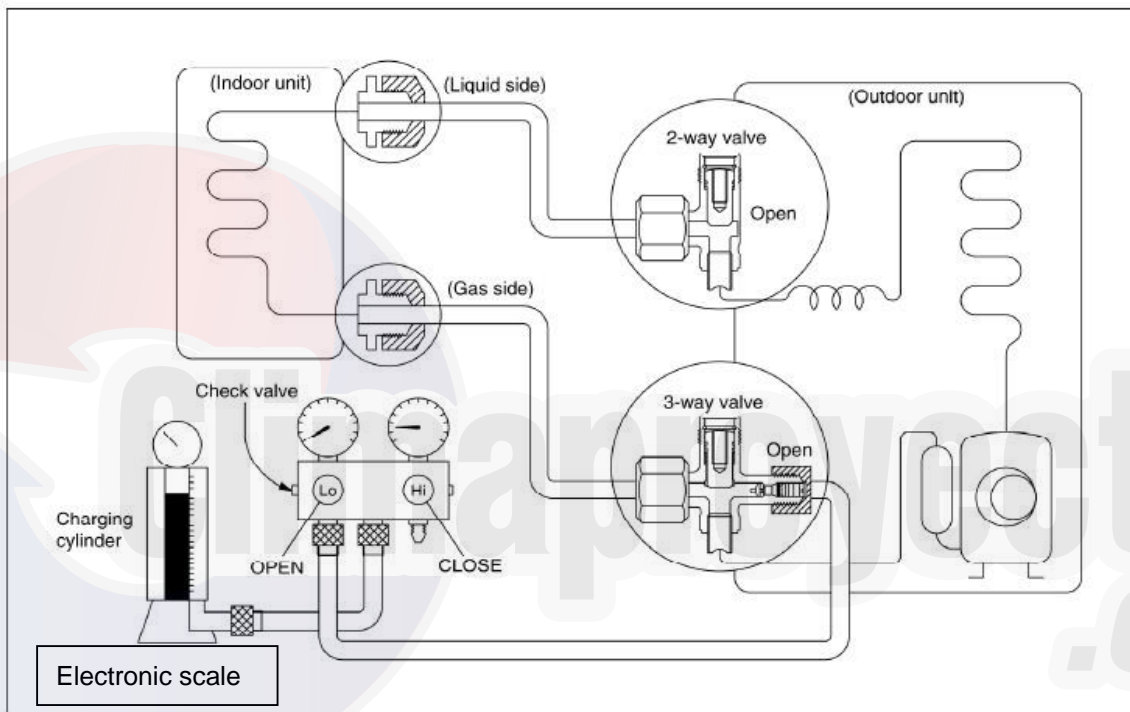

Procedure:

- 1). Connect the charge hose to the 3-way service port, open the 2-way valve and the 3-way valve. Connect the charge hose to the valve at the bottom of the cylinder. If the refrigerant is R410A, make the cylinder bottom up to ensure liquid charge.
- 2). Purge the air from the charge hose. Open the valve at the bottom of the cylinder and press the check valve on the charge set to purge the air (be careful of the liquid refrigerant).
- 3) Put the charging cylinder onto the electronic scale and record the weight.
- 4) Operate the air conditioner at the cooling mode.
- 5) Open the valves (Low side) on the charge set and charge the system with liquid refrigerant.

6).When the electronic scale displays the proper weight (refer to the gauge and the pressure of the low side), disconnect the charge hose from the 3-way valve's service port immediately and turn off the air conditioner before disconnecting the hose.

7). Mount the valve stem caps and the service port

Use torque wrench to tighten the service port cap to a torque of 18N.m.

Be sure to check for gas leakage.

6.6 Re-installation while the indoor unit need to be repaired

1. Collecting the refrigerant into the outdoor unit

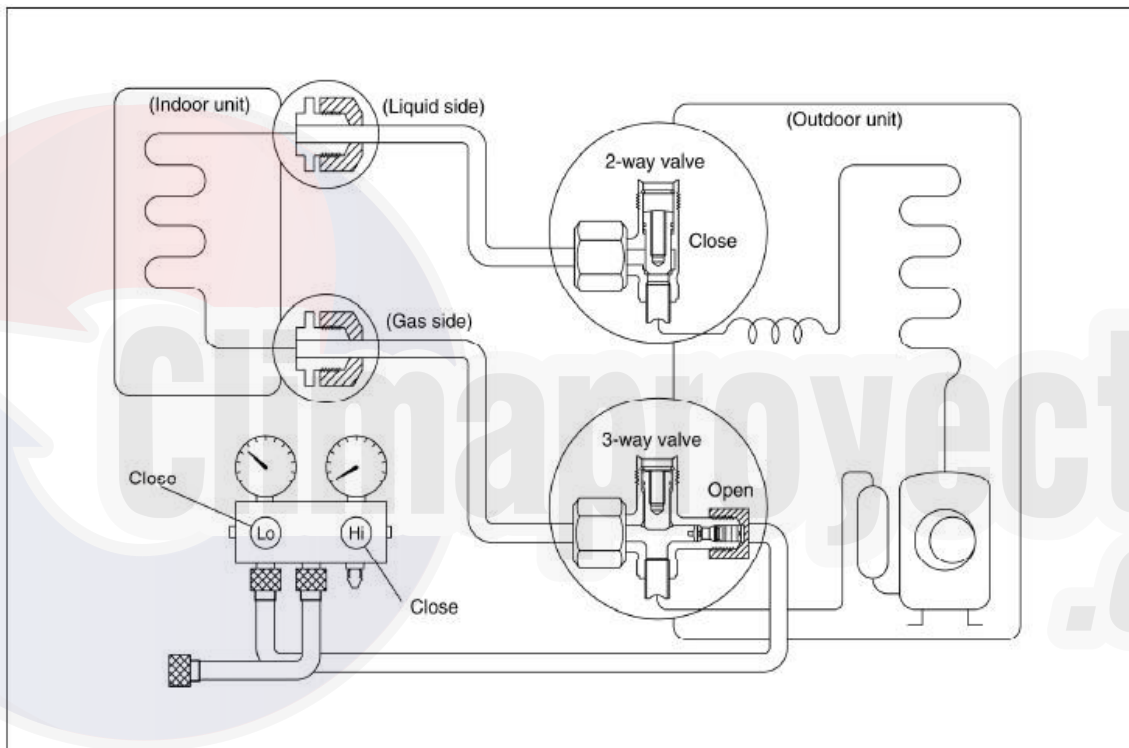

Procedure

1). Confirm that both the 2-way and 3-way valves are set to the opened position

Remove the valve stem caps and confirm that the valve stems are in the opened position.

Be sure to use a hexagonal wrench to operate the valve stems.

2). Connect the charge hose with the push pin of handle lo to the 3-way valves gas service port.

3). Air purging of the charge hose.

Open the handle Lo valve of the manifold valve slightly to purge air from the charge hose for 5 seconds and then close it quickly.

4). Set the 2-way valve to the close position.

- 5). Operate the air conditioner at the cooling cycle and stop it when the gauge indicates 0.1MPa.
- 6). Set the 3-way valve to the closed position immediately

Do this quickly so that the gauge ends up indicating 0.3 to 0.5Mpa.

Disconnect the charge set, and tighten the 2-way and 3-way valve's stem nuts.

Use a torque wrench to tighten the 3-way valves service port cap to a torque of 18N.m.

Be sure to check for gas leakage.

2. Air purging by the refrigerant

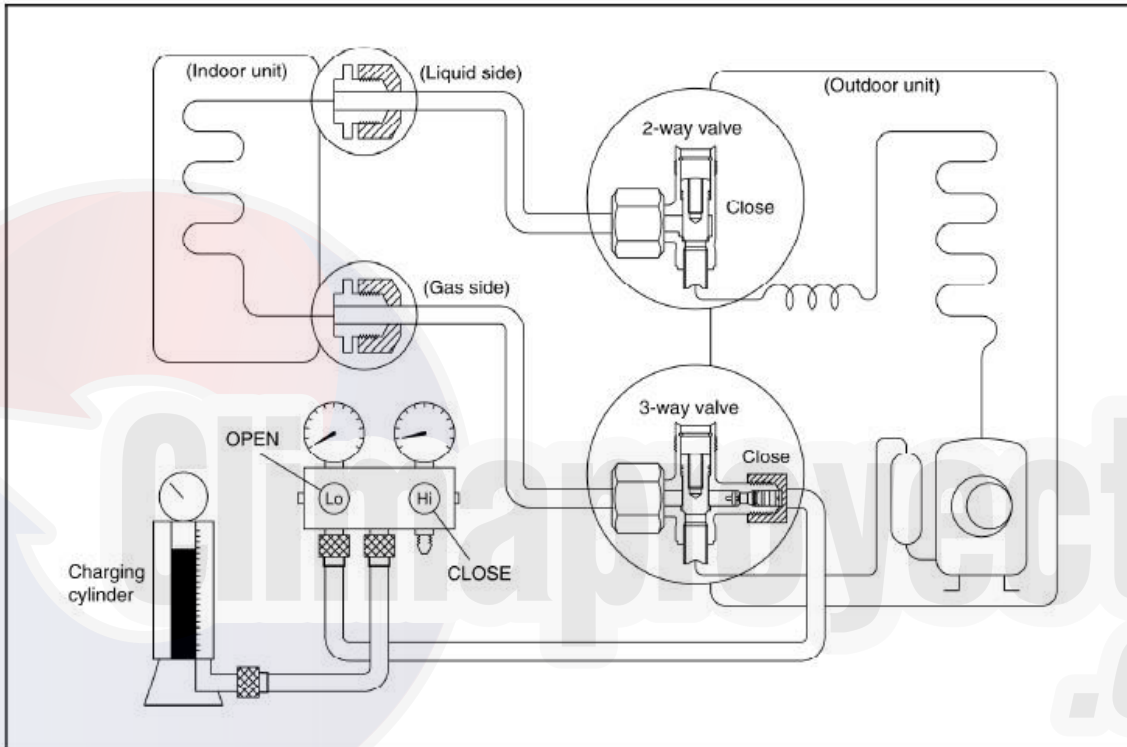

Procedure:

- 1). Confirm that both the 2-way and 3-way valves are set to the closed position.
- 2). Connect the charge set and a charging cylinder to the service port of the 3-way valve
Leave the valve on the charging cylinder closed.

- 3). Air purging.

Open the valves on the charging cylinder and the charge set. Purge the air by loosening the flare nut on the 2-way valve approximately 45' for 3 seconds then closing it for 1 minute; repeat 3 times.

After purging the air, use a torque wrench to tighten the flare nut on the 2-way valve.

- 4). Check the gas leakage

Check the flare connections for gas leakage.

- 5). Discharge the refrigerant.

Close the valve on the charging cylinder and discharge the refrigerant by loosening the flare nut on the 2-way valve approximately 45' until the gauge indicates 0.3 to 0.5 Mpa.

6). Disconnect the charge set and the charging cylinder, and set the 2-way and 3-way valves to the open position

Be sure to use a hexagonal wrench to operate the valve stems.

7). Mount the valve stems nuts and the service port cap

Be sure to use a torque wrench to tighten the service port cap to a torque 18N.m.

Be sure to check the gas leakage.

6.7 Re-installation while the outdoor unit need to be repaired

1. Evacuation for the whole system

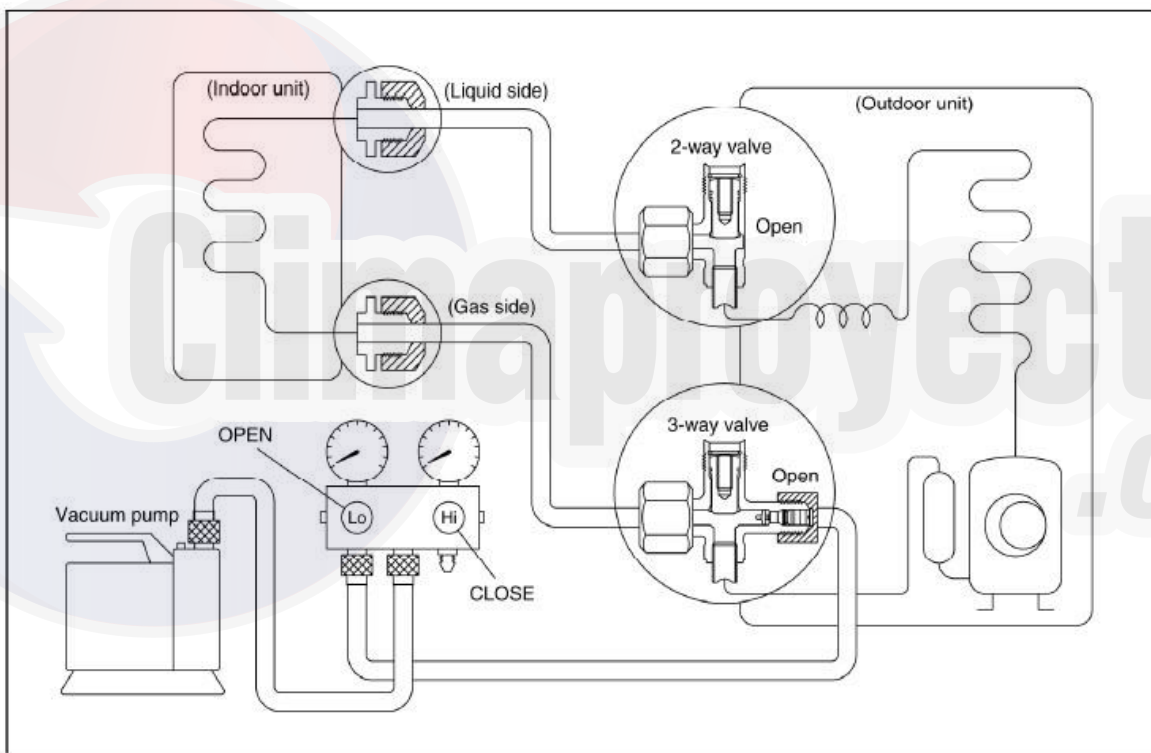

Procedure:

- 1). Confirm that both the 2-way and 3-way valves are set to the opened position.
- 2). Connect the vacuum pump to 3-way valve's service port.
- 3). Evacuation for approximately one hour. Confirm that the compound meter indicates -0.1Mpa.
- 4). Close the valve (Low side) on the charge set, turn off the vacuum pump, and confirm that the gauge needle does not move (approximately 5 minutes after turning off the vacuum pump).
- 5). Disconnect the charge hose from the vacuum pump.

2. Refrigerant charging

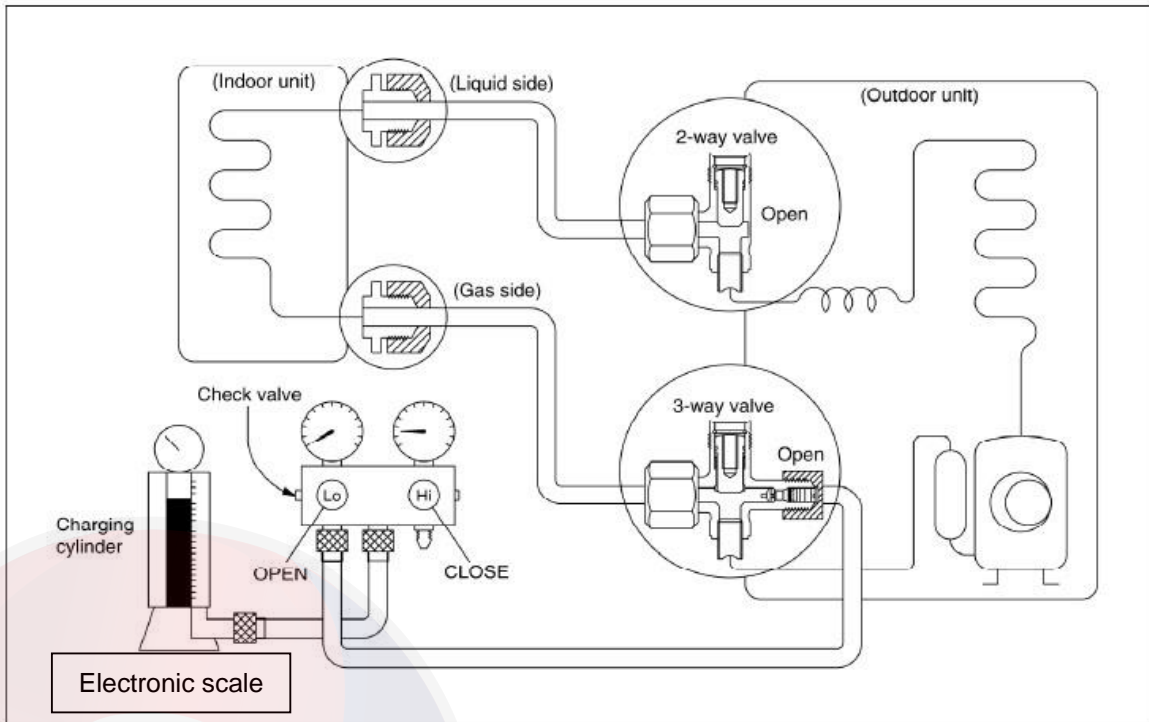

Procedure:

- 1). Connect the charge hose to the charging cylinder, open the 2-way valve and the 3-way valve
Connect the charge hose which you disconnected from the vacuum pump to the valve at the bottom of the cylinder. If the refrigerant is R410A, make the cylinder bottom up to ensure liquid charge.
- 2). Purge the air from the charge hose
Open the valve at the bottom of the cylinder and press the check valve on the charge set to purge the air (be careful of the liquid refrigerant).
- 3) Put the charging cylinder onto the electronic scale and record the weight.
- 4). Open the valves (Low side) on the charge set and charge the system with liquid refrigerant
If the system cannot be charge with the specified amount of refrigerant, or can be charged with a little at a time (approximately 150g each time) , operating the air conditioner in the cooling cycle; however, one time is not sufficient, wait approximately 1 minute and then repeat the procedure.
- 5).When the electronic scale displays the proper weight, disconnect the charge hose from the 3-way valve's service port immediately
If the system has been charged with liquid refrigerant while operating the air conditioner, turn off the air conditioner before disconnecting the hose.
- 6). Mounted the valve stem caps and the service port

Use torque wrench to tighten the service port cap to a torque of 18N.m.

Be sure to check for gas leakage.



7. Operation characteristics

Temperature Mode	Cooling operation	Heating operation	Drying operation
Room temperature	$\geq 17^{\circ}\text{C}(62^{\circ}\text{F})$	$\leq 30^{\circ}\text{C}(86^{\circ}\text{F})$	$> 10^{\circ}\text{C}(50^{\circ}\text{F})$
Outdoor temperature	$0^{\circ}\text{C} \sim 50^{\circ}\text{C}$ ($32^{\circ}\text{F} \sim 122^{\circ}\text{F}$)	$-15^{\circ}\text{C} \sim 30^{\circ}\text{C}$ ($5^{\circ}\text{F} \sim 86^{\circ}\text{F}$)	$0^{\circ}\text{C} \sim 50^{\circ}\text{C}$ ($32^{\circ}\text{F} \sim 122^{\circ}\text{F}$)
	$-15^{\circ}\text{C} \sim 50^{\circ}\text{C}(5^{\circ}\text{F} \sim 122^{\circ}\text{F})$ (For the models with low temperature cooling system)		

CAUTION:

1. If air conditioner is used outside of the above conditions, certain safety protection features may come into operation and cause the unit to function abnormally.
2. Room relative humidity less than 80%. If the air conditioner operates in excess of this figure, the surface of the air conditioner may attract condensation. Please sets the vertical air flow louver to its maximum angle (vertically to the floor), and set HIGH fan mode.
3. Optimum performance will be achieved within this operating temperature.

8. Electronic function

8.1 Abbreviation

T1: Indoor room temperature

T2: Coil temperature of evaporator

T3: Coil temperature of condenser





T4: Outdoor ambient temperature

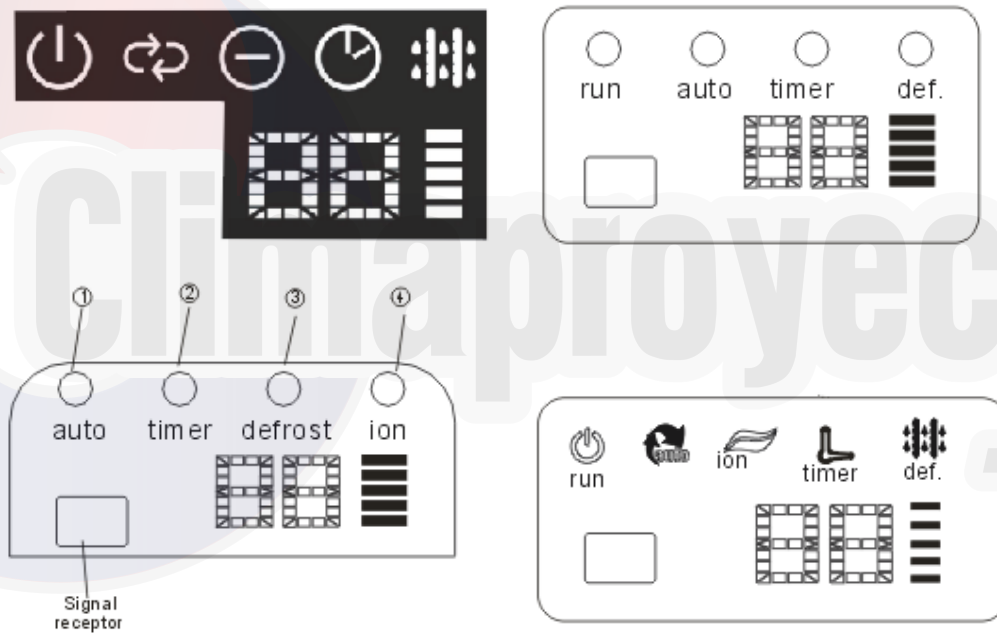

T5: Compressor discharge temperature

8.2 Display function

8.2.1 Icon explanation on indoor display board.



	OPERATION indication lamp: This lamp illuminates when the air conditioner is in operation.
	AUTO indication lamp: Lights up during the Auto operation.
	Ion indication lamp(optional function): Lights up when Clean Air feature is activated and Ionizer can generate abundant anions to fill the room with refreshing and natural air.
	TIMER indication lamp: Lights up during Timer operation.

	<p>DEFROST indication lamp (For cooling & heating models only):</p> <p>Lights up when the air conditioner starts defrosting automatically or when the warm air control feature is activated in heating operation.</p>
	<p>DIGITAL DISPLAY:</p> <p>Displays the current setting temperature and malfunction/protection code when the air conditioner is in operation.</p>
	<p>Frequency display: This display is separated into five zones. The zones illuminate based on the compressor current frequency. For example, higher frequency will illuminate more zones.</p>

8.3 Main Protection

8.3.1 Three Minutes Delay at restart for compressor

1 minute delay for the 1st time start-up and 3 minutes delay for others.

8.3.2 Temperature protection of compressor top

The unit will stop working when the compressor top temp. protector cut off, and will restart after the compressor top temp. protector restart.

8.3.3 Temperature protection of compressor discharge

When the compressor discharge temp. is getting higher, the running frequency will be limited as below rules:

---Compressor discharge temp. $T_5 > 115^\circ\text{C}$ for 5s, compressor stops.

--- $108 < T_5 < 115^\circ\text{C}$, decrease the frequency to the lower level every 3 minutes.

--- $90 < T_5 < 105^\circ\text{C}$, keep running at the current frequency.

---- $T_5 < 90^\circ\text{C}$, no limit for frequency.

8.3.4 Fan Speed is out of control

When Indoor Fan Speed keeps too low (300RPM) for certain time, the unit will stop and the LED will display the failure

8.3.5 Inverter module Protection

The Inverter module has a protection function about current, voltage and temperature. If these protections happen, the corresponding code will display on indoor unit and the unit will stop working.

8.3.6 Indoor fan delayed open function

When the unit starts up, the louver will be active immediately and the indoor fan will open 10s later.

If the unit runs in heating mode, the indoor fan will be also controlled by anti-cold wind function.

8.3.7 Compressor preheating functions

Preheating permitting condition:

If $T_4(\text{outdoor ambient temperature}) < 3^\circ\text{C}$ and the machine connects to power supply newly or if $T_4 < 3^\circ\text{C}$ and compressor has stopped for over 3 hours, the compressor heating cable will work.

Preheating mode:

A weak current flow through the coil of compressor from the wiring terminal of the compressor, then the compressor is heated without operation.

Preheating release condition:

If $T_4 > 5^\circ\text{C}$ or the compressor starts running, the preheating function will stop.

8.3.8 Zero crossing detection error protection

If AC detects time interval is not correct for continuous 240s, the unit will stop and the LED will display the failure. The correct zero crossing signal time interval should be between 6-13ms.

8.4 Operation Modes and Functions

8.4.1 Fan mode

- (1) Outdoor fan and compressor stop.
- (2) Temperature setting function is disabled, and no setting temperature is displayed.
- (3) Indoor fan can be set to high/med/low/auto.
- (4) The louver operates same as in cooling mode.
- (5) Auto fan:

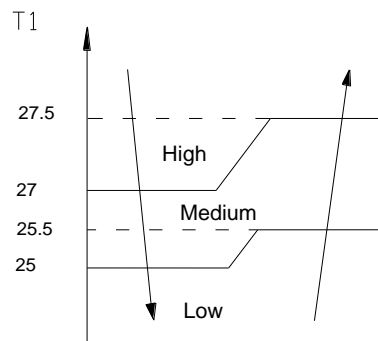

8.4.2 Cooling Mode

8.4.2.1 Compressor running rules:

The operation frequency of compressor after starting submits to following rule.

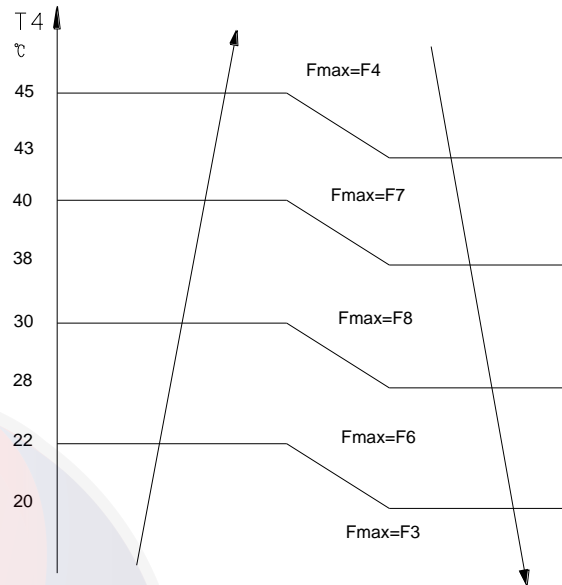

If users switch on AC by remote controller, the compressor will run at the Fmax frequency for 7 minutes according to the outdoor ambient temp. During the 7 minutes, the frequency limitation is active. 7 minutes later, the compressor running frequency will be controlled as below:

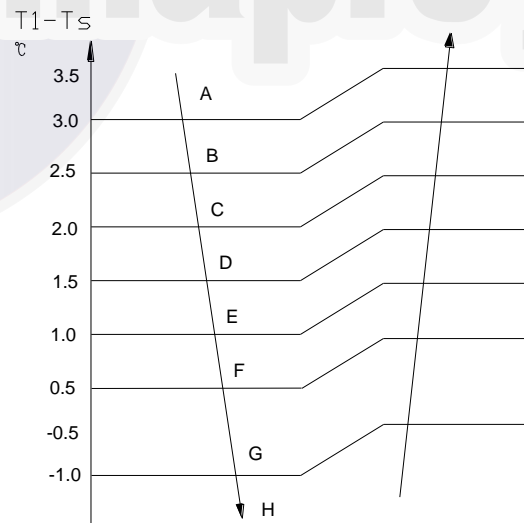

While the zones of A,B,C... are corresponding to different compressor running frequency.

Note:

When T1-Ts keeps in the same temp. zone for 3 minutes, the compressor will run as the below rules:

A~E: Increase the frequency to the higher level until to F8.

F: Keep the current frequency.

G: Decrease the frequency to the lower level until to F1.

H: Run at F1 for 1h.(if $T_1 - T_s < -2^\circ\text{C}$, the compressor will stop)

Meanwhile, the compressor running frequency is limited by the current.

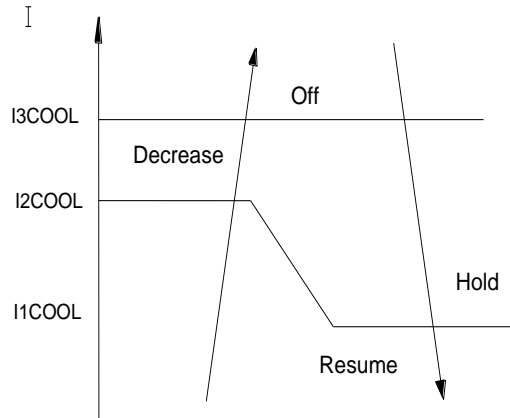

Off: Compressor stops.

Decrease: Decrease the running frequency to the lower level.

Hold: Keep the current frequency.

Resume: No limitation for frequency.

Note:

When AC is in "hold" zone for 3 minutes, the compressor frequency will rise to the higher level.(frequency will increase twice at most)

8.4.2.2 Outdoor fan running rules:

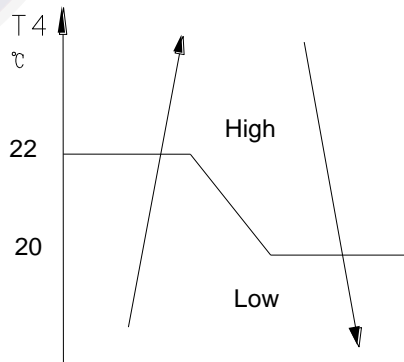

8.4.2.3 Indoor fan running rules

In cooling mode, indoor fan runs all the time and the speed can be selected as high, medium, low and auto.

Auto fan in cooling mode acts as follow:

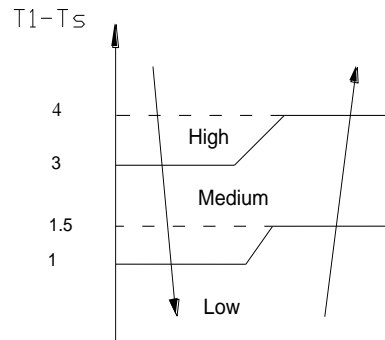

8.4.2.4 Condenser high temperature T3 protection.

--- $55^{\circ}\text{C} < \text{T3} < 60^{\circ}\text{C}$, the compressor frequency will decrease to the lower level until to F1 and then runs at F1. If $\text{T3} < 54^{\circ}\text{C}$, the compressor will keep running at the current frequency.

--- $\text{T3} < 52^{\circ}\text{C}$, the compressor will not limit the frequency and resume to the former frequency.

--- $\text{T3} > 60^{\circ}\text{C}$ for 5 seconds, the compressor will stop until $\text{T3} < 52^{\circ}\text{C}$.

8.4.2.5 Evaporator low temperature T2 protection.

--- $\text{T2} < 0^{\circ}\text{C}$, the compressor will stop and restart when $\text{T2} \geq 5^{\circ}\text{C}$.

--- $0^{\circ}\text{C} \leq \text{T2} < 4^{\circ}\text{C}$, the compressor frequency will be limited and decreased to the lower level

--- $4^{\circ}\text{C} \leq \text{T2} \leq 7^{\circ}\text{C}$, the compressor will keep the current frequency.

--- $\text{T2} > 7^{\circ}\text{C}$, the compressor frequency will not be limited.

8.4.3 Heating Mode

8.4.3.1 Compressor running rules:

The maximum operation frequency of the compressor after starting submits to the following rule.

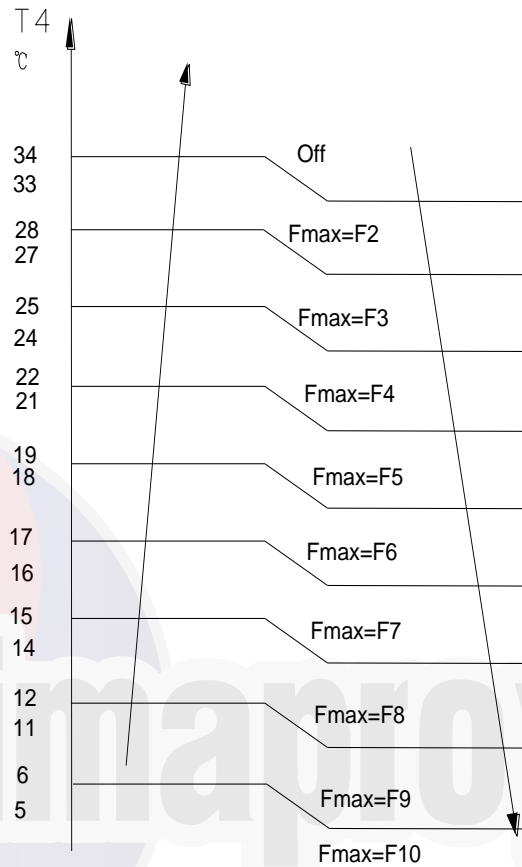

If users switch on AC by remote controller, the compressor will run at the Fmax frequency for 7 minutes according to outdoor ambient temp. During the 7 minutes, the frequency limitation is active.

7 minutes later, the compressor running frequency will be controlled as below:

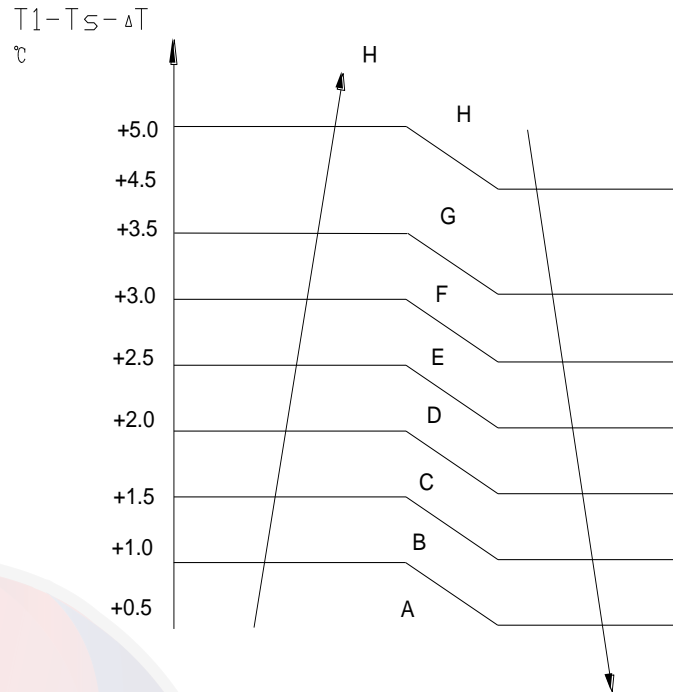

While the zones of A,B,C... are corresponding to different compressor running frequency.

$\Delta T = 0^\circ\text{C}$ as factory setting.

Note:

When $T_1 - T_s$ keeps in the same temp. zone for 3 minutes, the compressor will run as the below rules:

A~E: Increase the frequency to the higher level until to F10.

F: Keep the current frequency.

G: Decrease the frequency to the lower level until to F1.

H: Run at F1 for 1h. (if $T_1 - T_s - \Delta T > 6^\circ\text{C}$, the compressor will stop)

Meanwhile, the compressor running frequency is limited by the current.

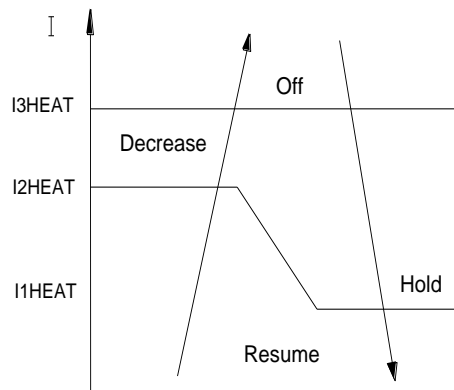

Off: Compressor stops.

Decrease: Decrease the running frequency to the lower level.

Hold: Keep the current frequency.

Resume: No limitation for frequency.

Note:

When AC is in “hold” zone for 3 minutes, the compressor frequency will rise to the higher level. (The frequency will increase twice at most)

8.4.3.2 Outdoor fan running rules:

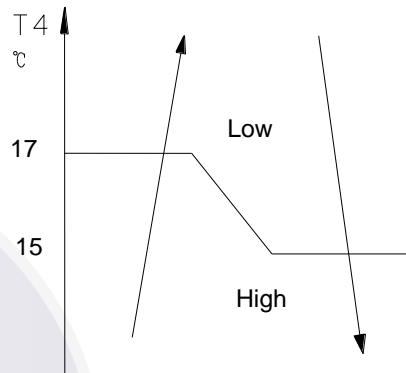

8.4.3.3 Indoor fan running rules:

For 9k,12k, MS9A-18HRDN1-MS0W models:

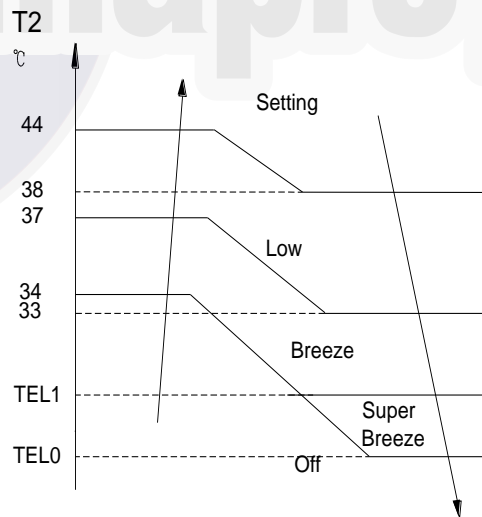

TEL1=24, TEL0=17.

For other models:

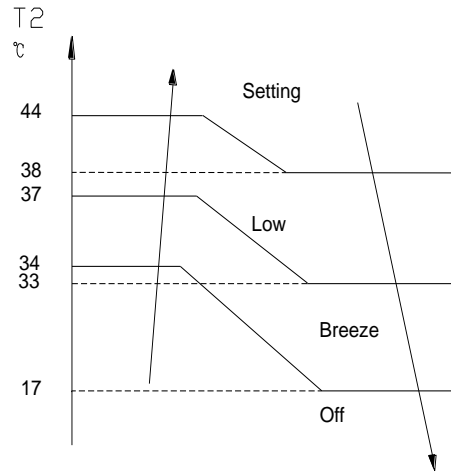

If the compressor stops caused by the room temperature rising, the indoor fan will be forced to run 127 seconds with breeze. During this period, the anti-cold-wind is disabled.

If the machine runs in rating capacity test mode, the indoor fan will run with rating speed and the anti-cold-wind function is disabled.

Indoor fan speed can be set as high, medium, low or auto fan and the anti-cold-wind function is preferential.

Auto fan action in heating mode:

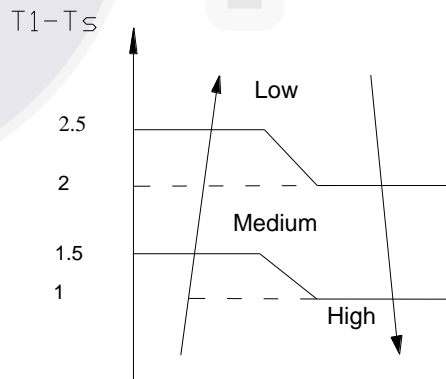

8.4.3.4 Defrosting mode

Condition of defrosting:

---- $T_4 > 0^\circ\text{C}$,

When the units are running, if the following two items are satisfied, the units start defrosting:

The units run with $T_3 < 3^\circ\text{C}$ for 40 minutes and T_3 keeps lower than $T_{CDI}^\circ\text{C}$ for more than 3 minutes.

The units run with $T_3 < 3^\circ\text{C}$ for 80 minutes and T_3 keeps lower than $T_{CDI} + 2^\circ\text{C}$ for more than 3

minutes.

---- $T_4 < 0^\circ\text{C}$,

If the 1st condition and 2nd condition items are satisfied, then the program judges if T2 has decreased more than 5°C . When T2 has decreased more than 5°C , enter the defrosting mode.

----No matter what value T4 is, if the machine runs with $T_3 < 3^\circ\text{C}$ for more than 120 minutes and T3 keeps lower than $\text{TCDI} + 4^\circ\text{C}$ for more than 3 minutes, the machine will enter defrosting mode no matter if T2 drops more than 5°C or not.

Condition of ending defrosting:

If any one of the following items is satisfied, the defrosting will finish and the machine will turn to normal heating mode.

----T3 rises to be higher than $\text{TCDE}1^\circ\text{C}$.

----T3 keeps to be higher than $\text{TCDE}2^\circ\text{C}$ for 80 seconds.

----The machine has run for 10 minutes in defrosting mode.

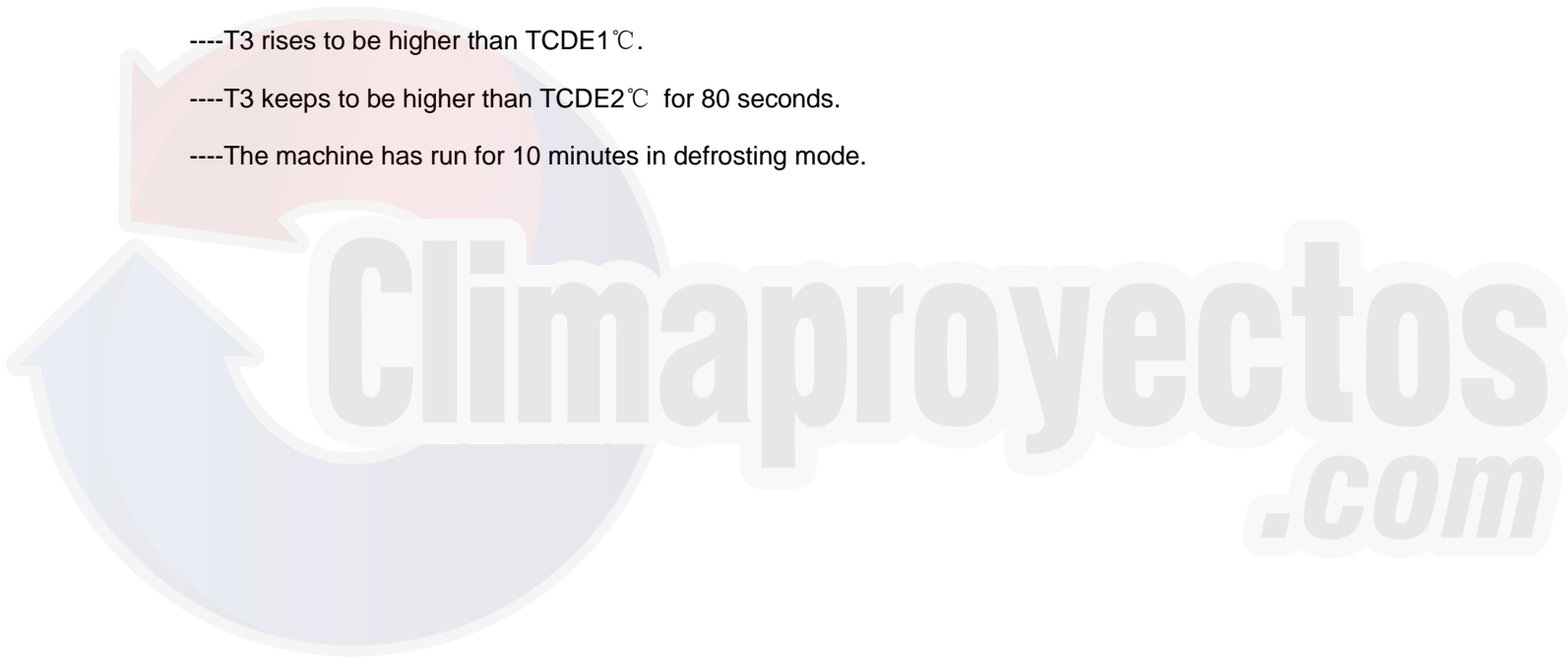

Defrosting action:

For 18k, 24k models:

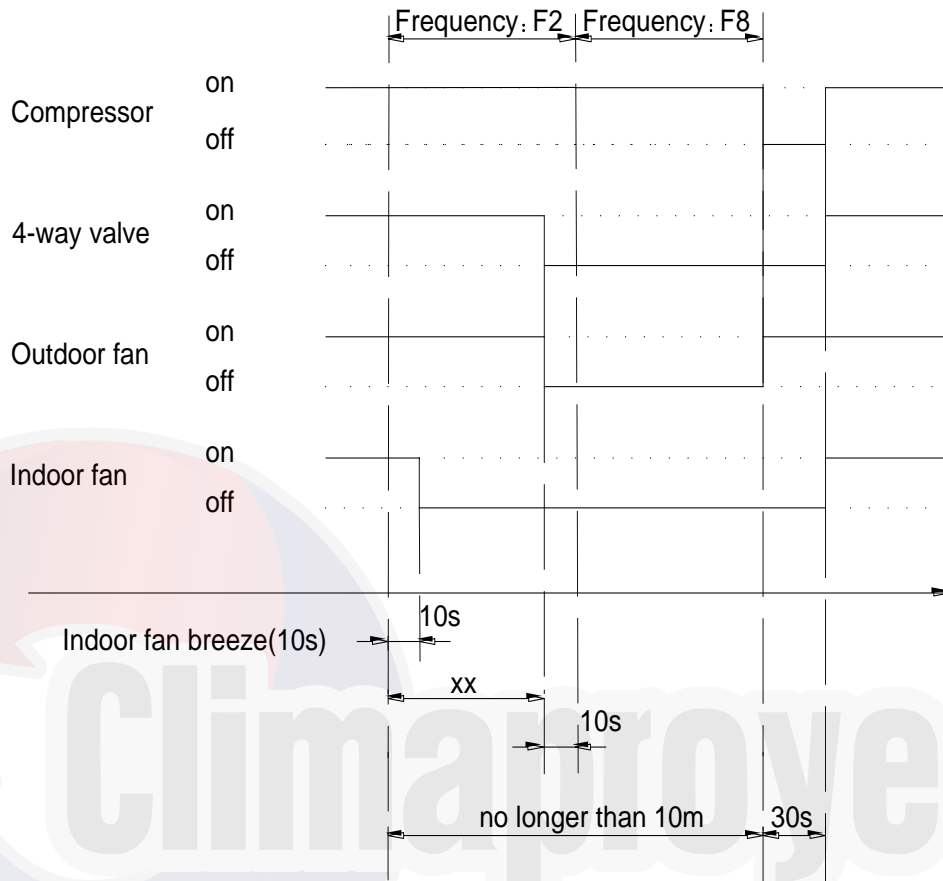

Model	XX
MS9A-18HRDN1-MS0W, MS9A-24HRDN1-MS0W	60
MS9A-18HRDN1-MP0W MS9A-24HRDN1-MP0W MS9A-24CRDN1-MP0W	90

For other models:

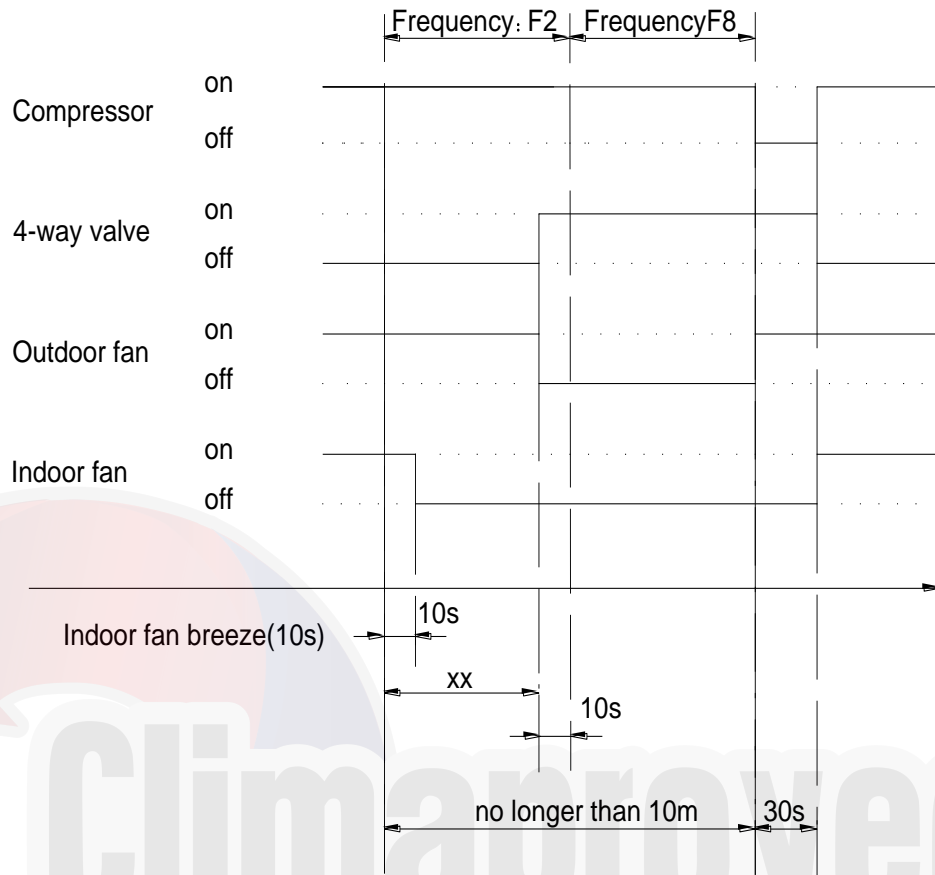

XX=60.

8.4.3.5 Evaporator coil temperature protection

--- $T_2 > TEH2^{\circ}C$, the compressor running frequency decreases to the lower level and runs for 20s.

When the frequency decreases to F2 and the T_2 is still over $TEH2^{\circ}C$ for 3 minutes, the compressor will stop.

--- $T_2 < 48^{\circ}C$ or T_2 stays in $48^{\circ}C \sim TEH2^{\circ}C$ for 6 minutes, the frequency will not be limited by T_2 .

--- $T_2 > 60^{\circ}C$, the compressor will stop and restart when $T_2 < 48^{\circ}C$.

8.4.4 Auto-mode

This mode can be chosen with remote controller and the setting temperature can be changed between $17 \sim 30^{\circ}C$.

In auto mode, the machine will choose cooling, heating or fan-only mode according to ΔT ($\Delta T = T_1 - T_s$).

$\Delta T = T_1 - T_s$	Running mode
$\Delta T > 1^{\circ}C$	Cooling

$-1 < \Delta T \leq 1^{\circ}\text{C}$	Fan-only
$\Delta T \leq -1^{\circ}\text{C}$	Heating

Indoor fan will run at auto fan of the relevant mode.

The louver operates same as in relevant mode.

If the machine switches mode between heating and cooling, the compressor will keep stopping for 15 minutes and then choose mode according to $T1 - T_s$.

If the setting temperature is modified, the machine will choose running function again.

8.4.5 Drying mode

8.4.5.1 Indoor fan speed is fixed at breeze and can't be changed. The louver angle is the same as in cooling mode.

8.4.5.2 Compressor running rules

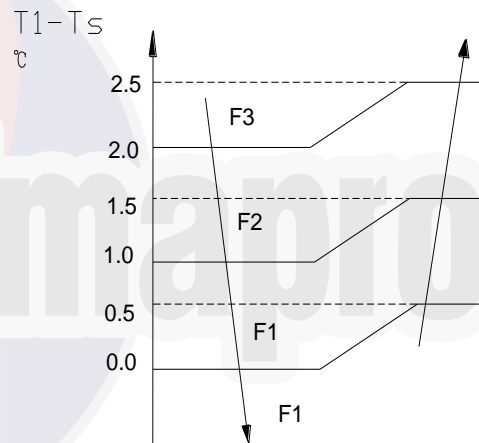

8.4.5.3 Low indoor room temperature protection

In drying mode, if room temperature is lower than 10°C , the compressor will stop and not resume until room temperature exceeds 12°C .

8.4.5.4 Evaporator anti-freezing protection, condenser high temperature protection and outdoor unit frequency limit are active and the same as that in cooling mode.

8.4.5.5 The outdoor fan operates the same as in cooling mode.

8.4.6 Forced operation function

8.4.6.1 Enter forced operation function:

When the machine is off, pressing the touch button will carry the machine to forced auto mode. After this, pressing the button once again within 5 seconds, the machine will turn into forced cooling mode.

In forced auto, forced cooling or any other operation mode, pressing touch button will turn off the

machine.

8.4.6.2 In forced operation mode, all general protections and remote control are available.

8.4.6.3 Operation rules:

Forced cooling mode:

The compressor runs at F2 frequency and indoor fan runs as breeze. After running for 30 minutes, the machine will turn to auto mode as 24°C setting temperature.

Forced auto mode:

The action of forced auto mode is the same as normal auto mode with 24°C setting temperature.

8.4.7 Timer function

8.4.7.1 Timing range is 24 hours.

8.4.7.2 Timer on. The machine will turn on automatically when reaching the setting time.

8.4.7.3 Timer off. The machine will turn off automatically when reaching the setting time.

8.4.7.4 Timer on/off. The machine will turn on automatically when reaching the setting “on” time, and then turn off automatically when reaching the setting “off” time.

8.4.7.5 Timer off/on. The machine will turn off automatically when reaching the setting “off” time, and then turn on automatically when reaching the setting “on” time.

8.4.7.6 The timer function will not change the AC current operation mode. Suppose AC is off now, it will not start up firstly after setting the “timer off” function. And when reaching the setting time, the timer LED will be off and the AC running mode has not been changed.

8.4.7.7 The setting time is relative time.

8.4.8 Sleep function mode

8.4.8.1 Operation time in sleep mode is 7 hours. After 7 hours the AC quits this mode and turns off.

8.4.8.2. Operation process in sleep mode is as follow:

When cooling, the setting temperature rises 1°C (be lower than 30°C) every one hour, 2 hours later the setting temperature stops rising and indoor fan is fixed as low speed.

When heating, the setting temperature decreases 1°C (be higher than 17°C) every one hour, 2 hours later the setting temperature stops rising and indoor fan is fixed as low speed. (Anti-cold wind function has the priority)

8.4.8.3 Timer setting is available

8.4.8.4 When user uses timer off function in sleep mode (or sleep function in timer off mode), if the

timing is less than 7 hours, sleep function will be cancelled when reaching the setting time. If the timing is more than 7 hours, the machine will not stop until reaches the setting time in sleep mode.

8.4.9 Auto-Restart function

The indoor unit is equipped with auto-restart function, which is carried out through an auto-restart module. In case of a sudden power failure, the module memorizes the setting conditions before the power failure. The unit will resume the previous operation setting (not including swing function) automatically after 3 minutes when power returns.

If the memorization condition is forced cooling mode, the unit will run in cooling mode for 30 minutes and turn to auto mode as 24°C setting temp.

If AC is off before power off and AC is required to start up now, the compressor will have 1 minute delay when power on. Other conditions, the compressor will have 3 minutes delay when restarts.

8.4.10 8°C Heating(optional)

In heating operation, the preset temperature of the air conditioner can be as lower as 8°C, which keeps the room temperature steady at 8°C and prevents household things freezing when the house is unoccupied for a long time in severe cold weather.

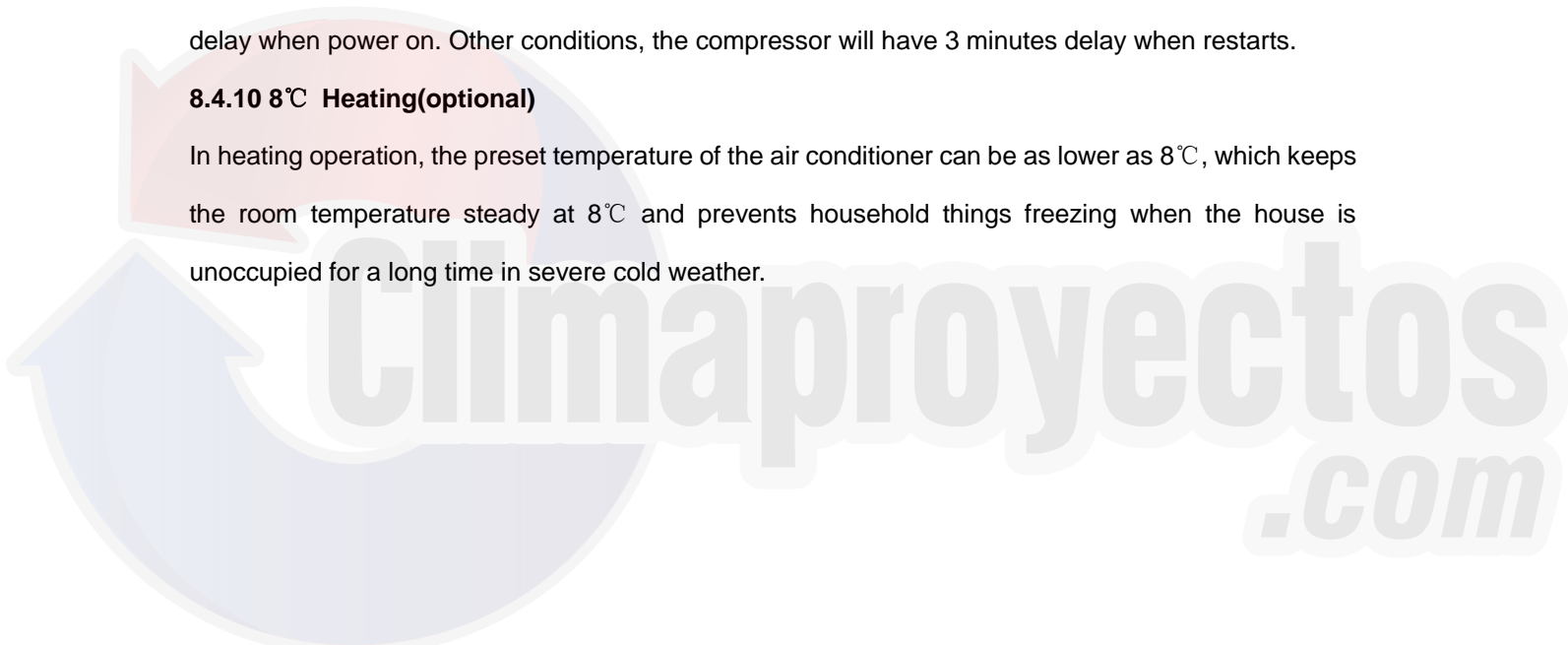

9. Troubleshooting

Safety

Electricity power is still kept in capacitors even the power supply is shut off. Do not forget to discharge the electricity power in capacitor.

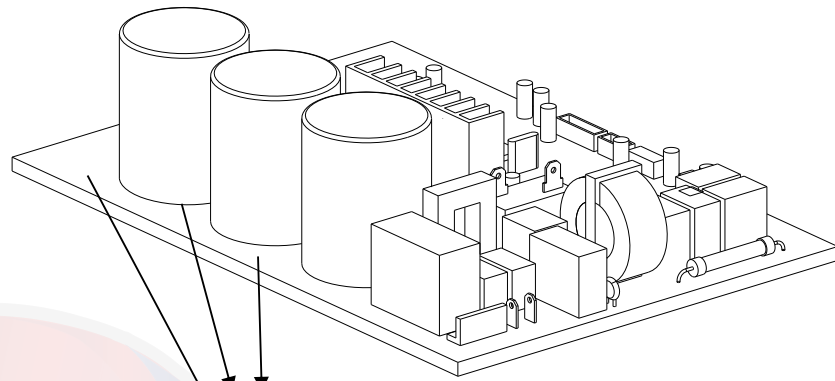

Electrolytic Capacitors
(HIGH VOLTAGE! CAUTION!)

Connect discharge resistance (approx.100Ω 40W) or soldering iron (plug) between +, - terminals of the electrolytic capacitor on the contrary side of the outdoor PCB.

Discharging position
(Discharging period
10 seconds or more)

Plug of soldering
iron

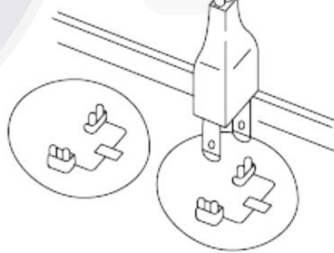

Note: The picture above is only for reference. The plug of your side may be different.

9.1 Indoor Unit Error Display

Display	LED STATUS
E0	EEPROM parameter error
E1	Indoor / outdoor units communication protection
E2	Zero-crossing signal error
E3	Indoor fan speed has been out of control
E5	Open circuit or short circuit of outdoor temperature sensor or outdoor unit EEPROM parameter error
E6	Open circuit or short circuit of room or evaporator temperature sensor
E7	Outdoor fan speed has been out of control(only for MS9A-09HRDN1-BQ0W, MS9A-12HRDN1-BS0W(B), MS9A-09CRDN1-BS0W, MS9A-12CRDN1-BS0W, MS9A-09HRDN1-BS0W, MS9A-12HRDN1-BS0W, MS9A-18CRDN1-MS0W, MS9A-12HRDN1-MS0W, MS9A-18HRDN1-MS0W)
P0	IPM malfunction or IGBT over-strong current protection
P1	Over voltage or too low voltage protection
P2	Temperature protection of compressor top.(except MS9A-24HRDN1-MP0W 2T0033000364, MS9A-24HRDN1-MS0W 2T0033000389)
P3	Outdoor temperature is lower than 15 °C (optional function)
P4	Inverter compressor drive error

Note: E4 & P3: Reserved function.

Note

P3: If the outdoor temperature ≤ -15 °C for 1 hour, then the machine stops running, the indoor display shows the error code "P3". The unit can still receive remote control signals.

If the outdoor ≥ -12 °C for 10 minutes, the compressor stops running more than one hour,

Or the outdoor temperature ≥ 5 °C for 10 minutes, then AC will recover to the last mode and fan speed.

E4 : Reserved function.



9.2 Outdoor unit error display

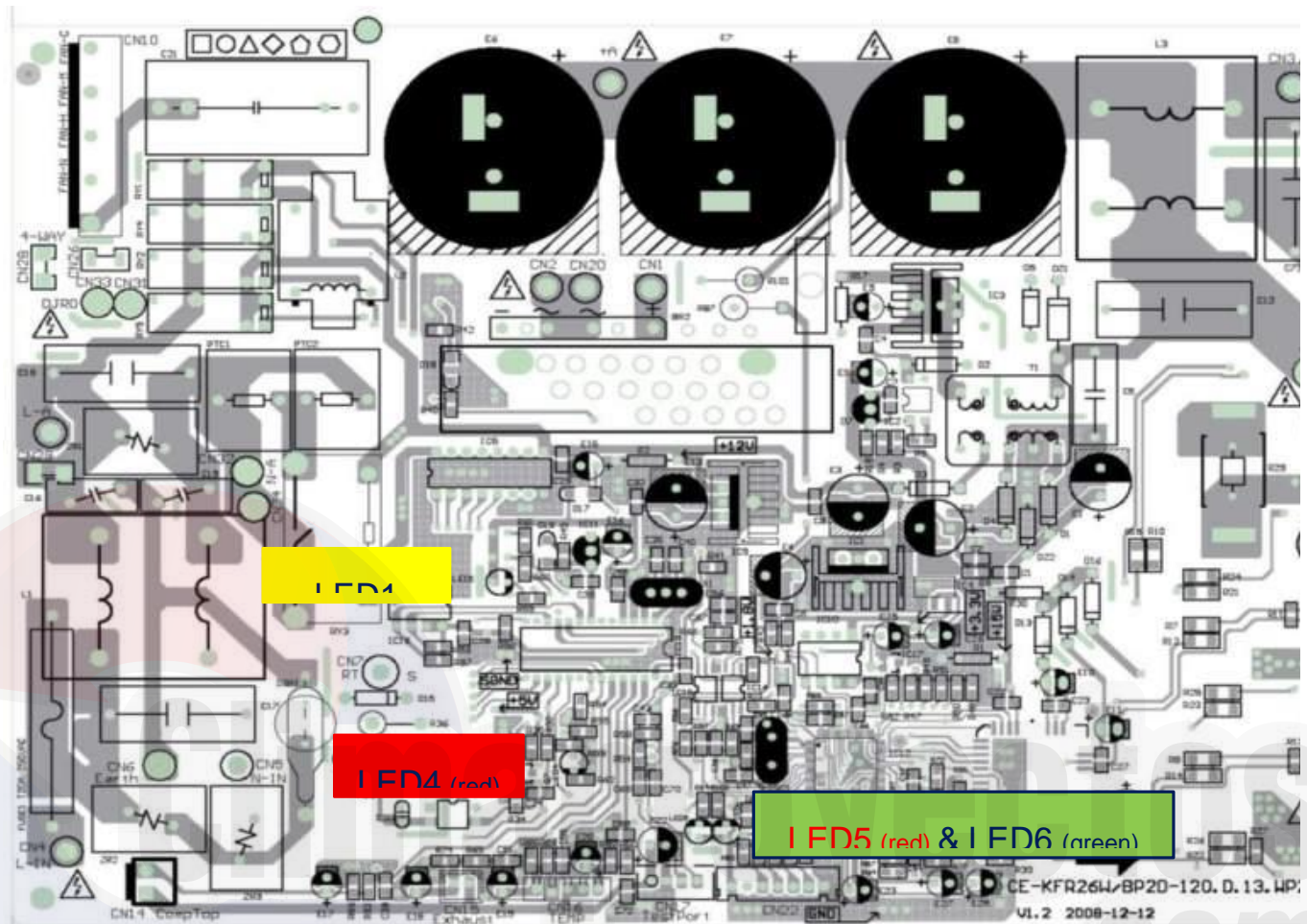

	standby	operating
LED1	slow flashing	on
LED4	on	on

The picture of PCB above is only for reference.

LED 4 is a red light and for the PCB POWER display.

LED 1 is a yellow light. After power on, it will be slow flash when the unit is in standby and quick flash(2.5Hz) if the unit has some problems.

LED 6(green) and LED5(red) are two lights controlled by the compressor drive chip. Below is meanings for those lights.

No.	Problems	LED6	LED5	IU display
1	standby for normal	O	X	
2	Operation normally	X	O	
3	IPM malfunction or IGBT over-strong current protection	☆	X	P0

4	Over voltage or too low voltage protection	O	O	P1
5	Over voltage or too low voltage protection	O	☆	P1
6	Inverter compressor drive error	X	☆	P4
7	Inverter compressor drive error	☆	O	P4
8	Inverter compressor drive error	☆	☆	P4

O (light)

X (off)

☆ (2.5Hz flash)



9.3 Diagnosis and Solution

9.3.1 EEPROM parameter error diagnosis and solution(E0)

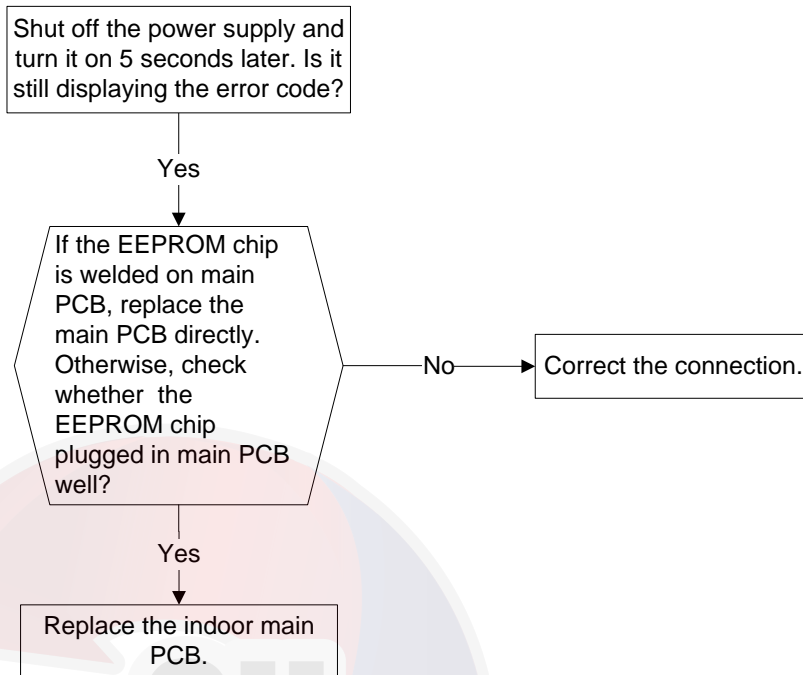

EEPROM: a read-only memory whose contents can be erased and reprogrammed using a pulsed voltage.

9.3.2 Indoor / outdoor units communication diagnosis and solution(E1)

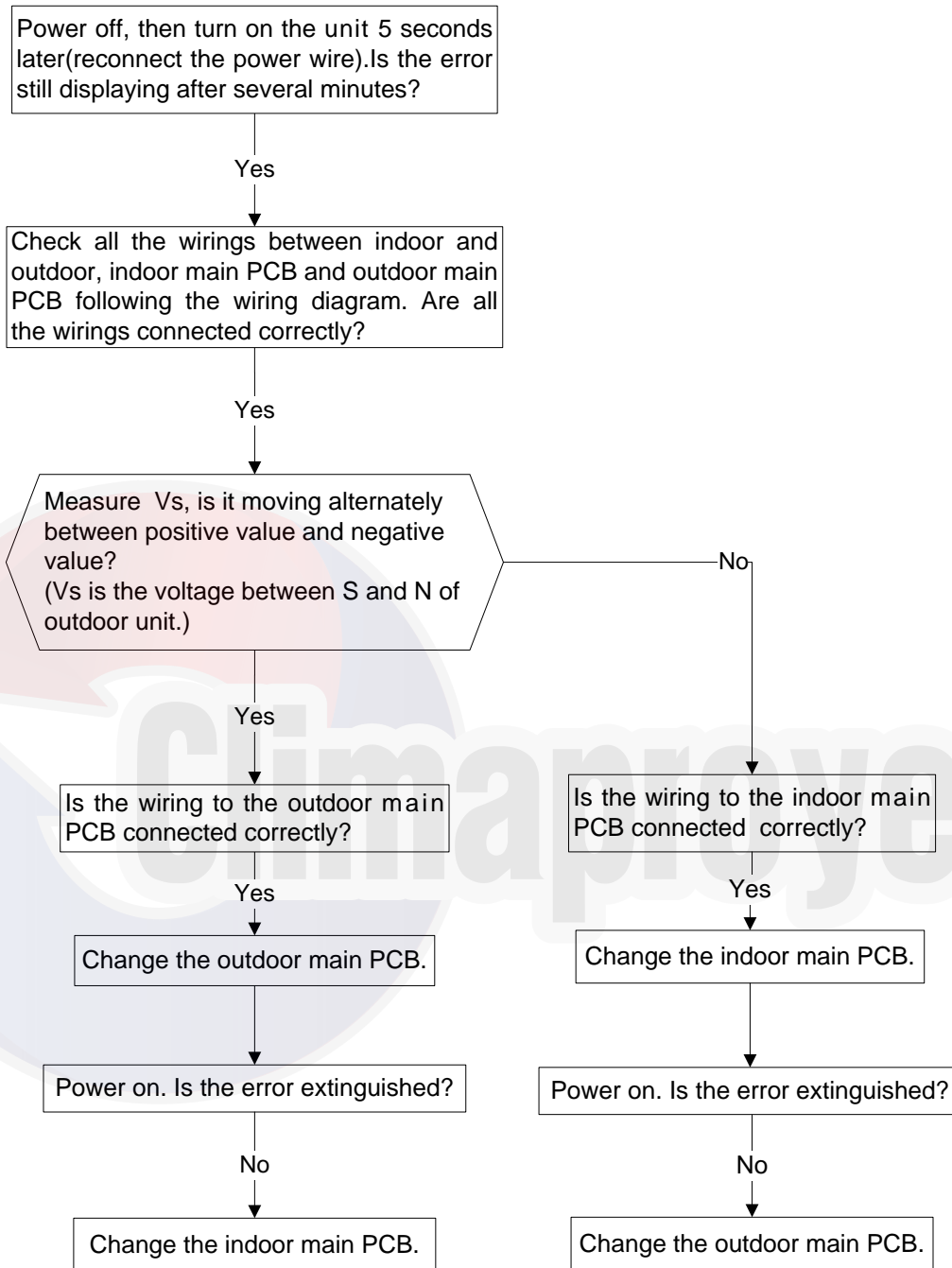

9.3.3 Zero crossing detection error diagnosis and solution(E2)

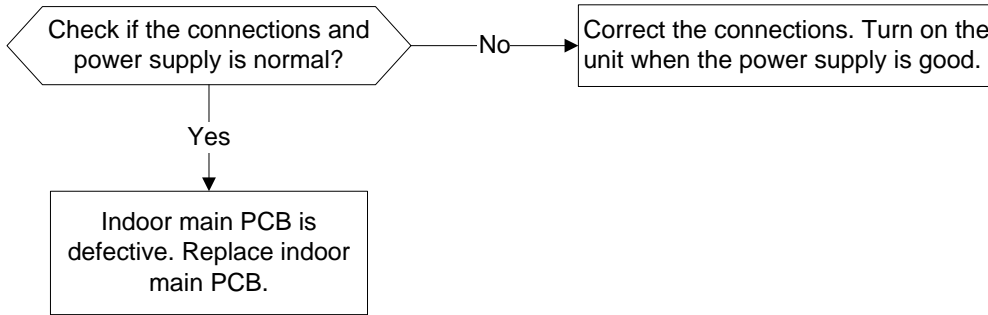

9.3.4 Fan speed has been out of control diagnosis and solution(E3/E7)

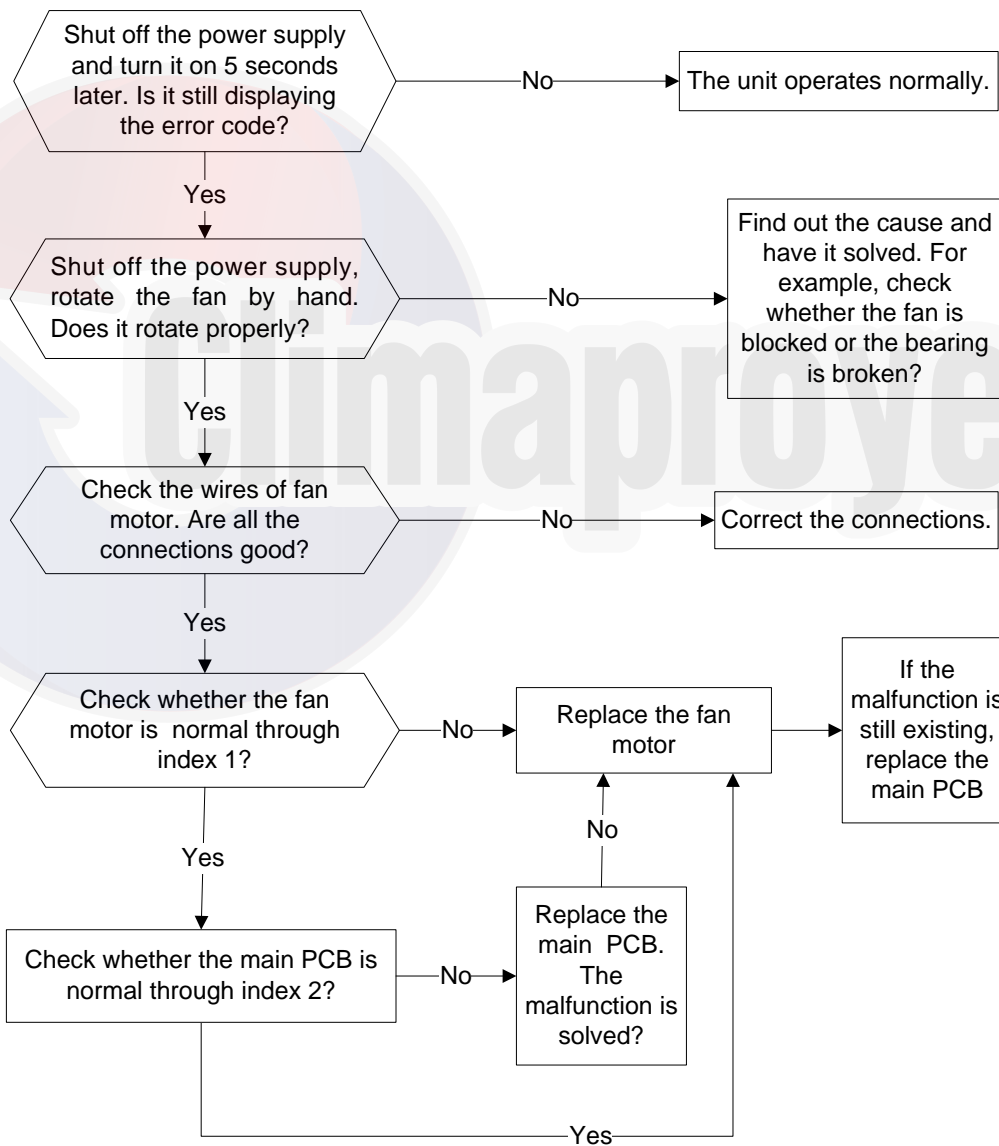

Index 1:

1. Indoor AC Fan Motor

Measure the resistance value of each winding by using the tester.

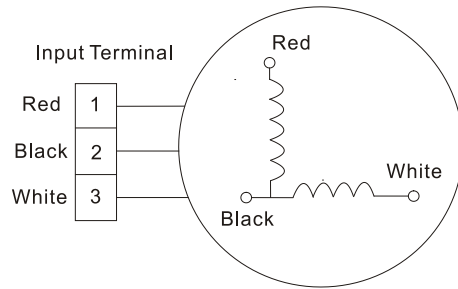

For the definite value of the resistance, contact the technical engineer.

2. Outdoor DC Fan Motor(control chip is in fan motor)

Measure the resistance value of each winding by using the tester. If any resistance value is zero, the fan motor must has problems and need to be replaced.

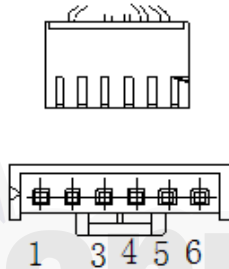

Index2:

1: Indoor AC Fan Motor

Power on and set the unit running in fan mode at high fan speed. After running for 15 seconds, measure the voltage of pin1 and pin2. If the value of the voltage is less than 100V(208~240V power supply)or 50V(115V power supply), the PCB must has problems and need to be replaced.

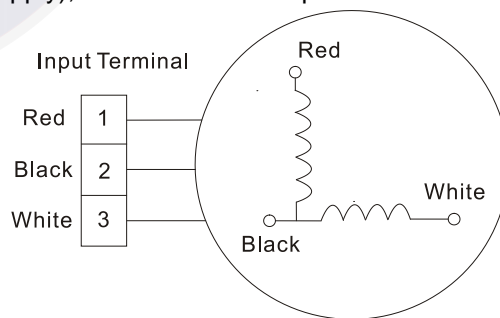

2. Outdoor DC Fan Motor(control chip is in fan motor)

Power on and when the unit is in standby, measure the voltage of pin1-pin3, pin4-pin3 in fan motor connector. If the value of the voltage is not in the range showing in below table, the PCB must has problems and need to be replaced.

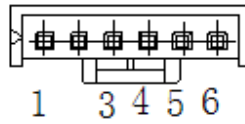
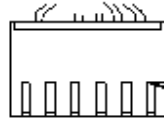

DC motor voltage input and output

NO.	Color	Signal	Voltage
1	Red	Vs/Vm	280V~380V
2	---	---	---
3	Black	GND	0V
4	White	Vcc	14-17.5V
5	Yellow	Vsp	0~5.6V
6	Blue	FG	14-17.5V

Climaproyectos
.com

9.3.5 Open circuit or short circuit of temperature sensor diagnosis and solution(E5/E6)

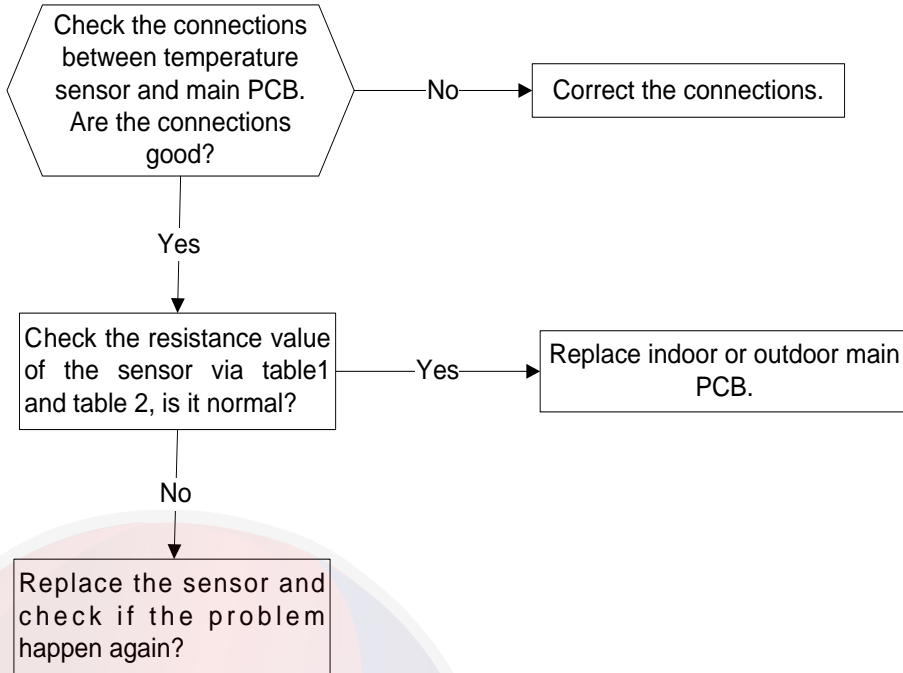

9.3.6 IPM malfunction or IGBT over-strong current protection diagnosis and solution(P0)

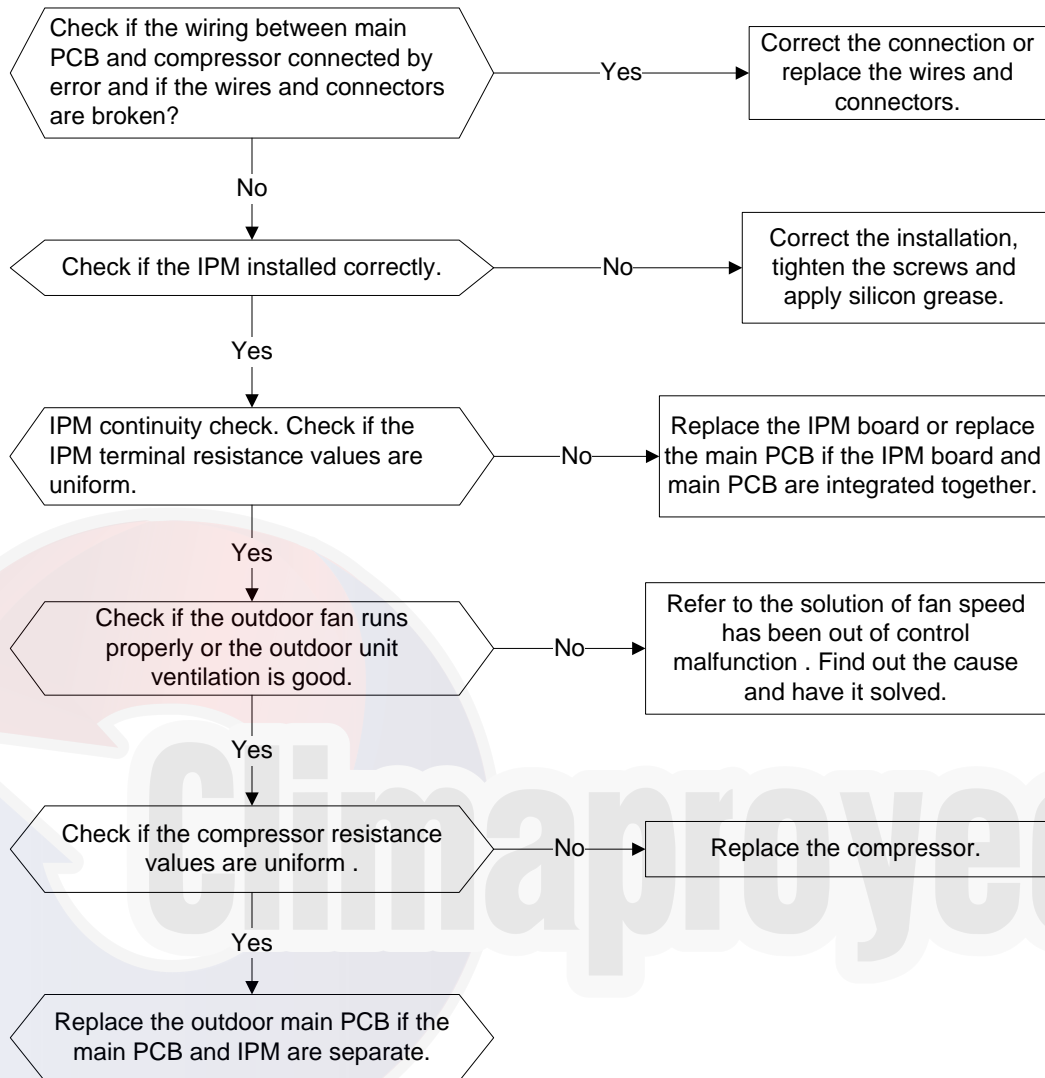

9.3.8 Over voltage or too low voltage protection diagnosis and solution(P1)

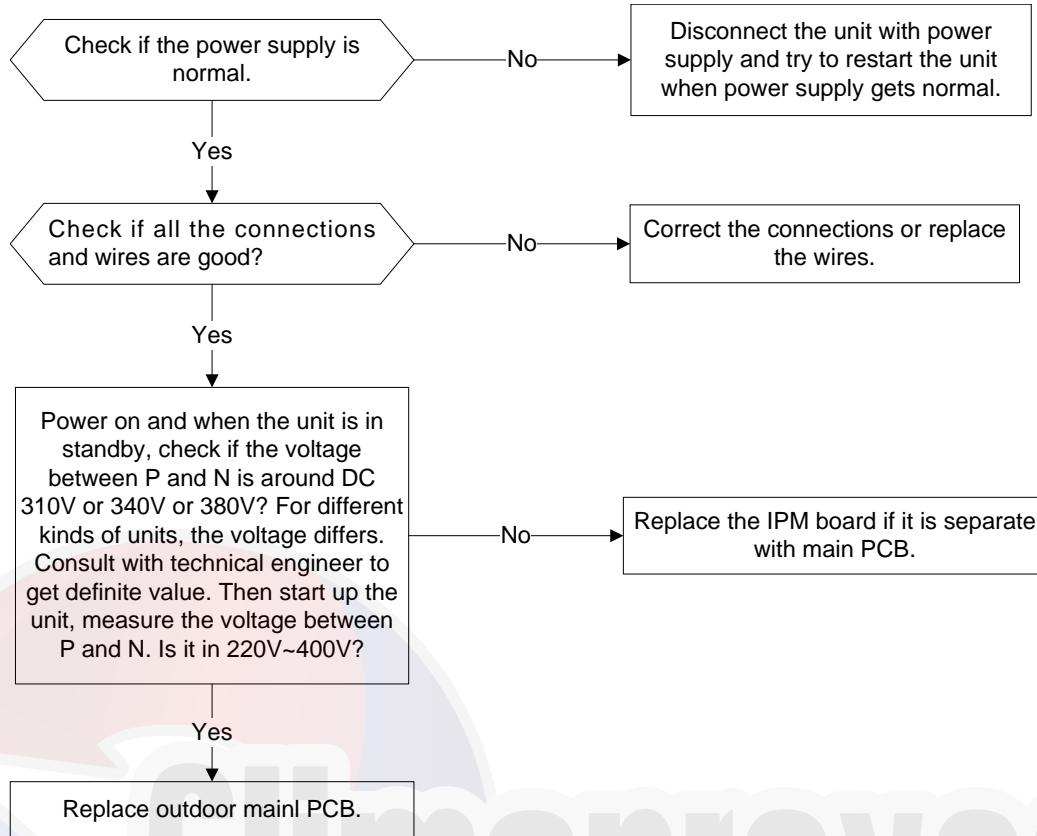

9.3.9 High temperature protection of compressor top diagnosis and solution(P2)

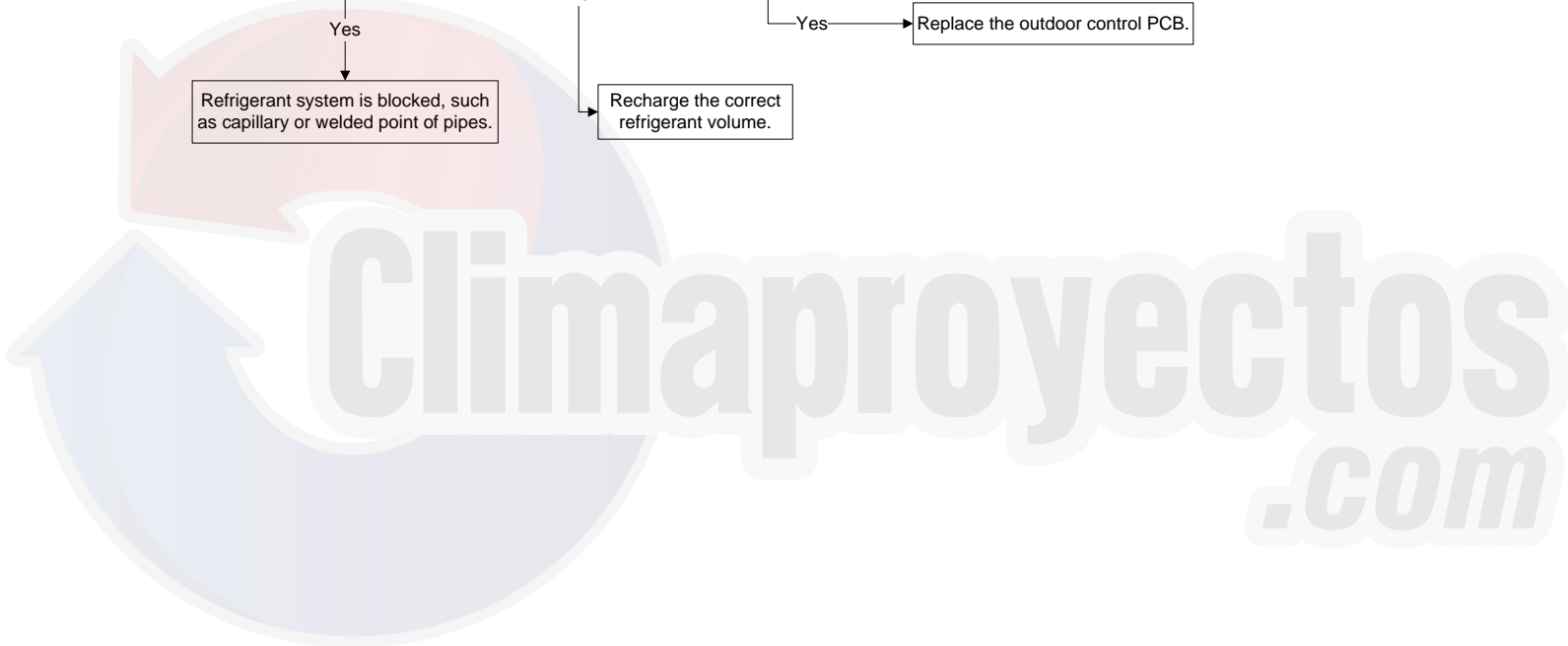
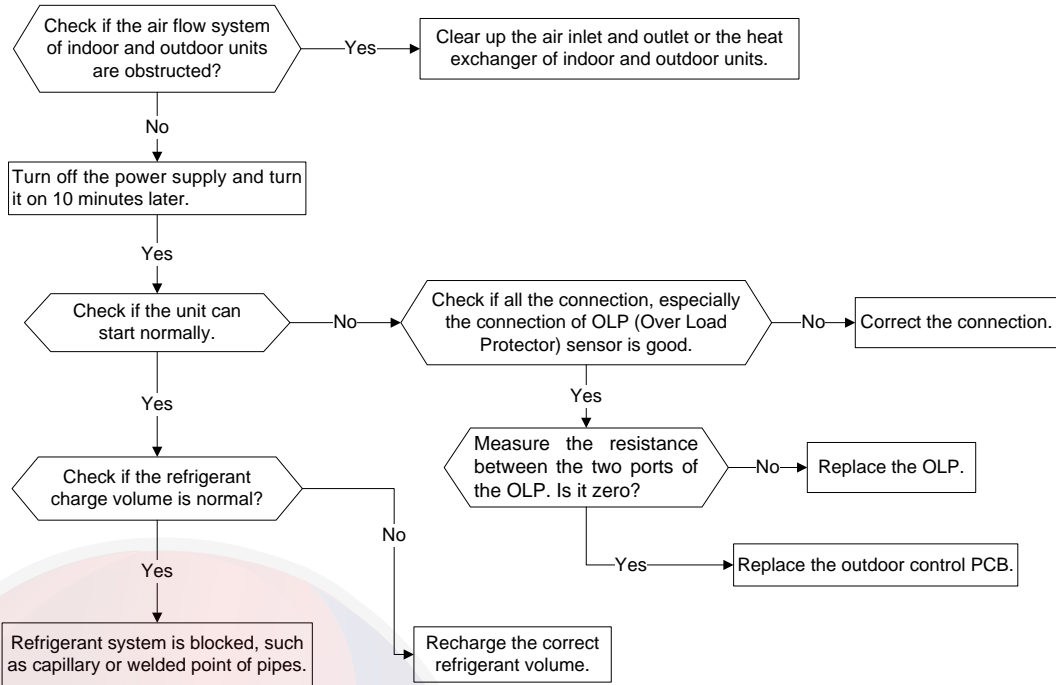

9.3.10 Inverter compressor drive error diagnosis and solution(P4)

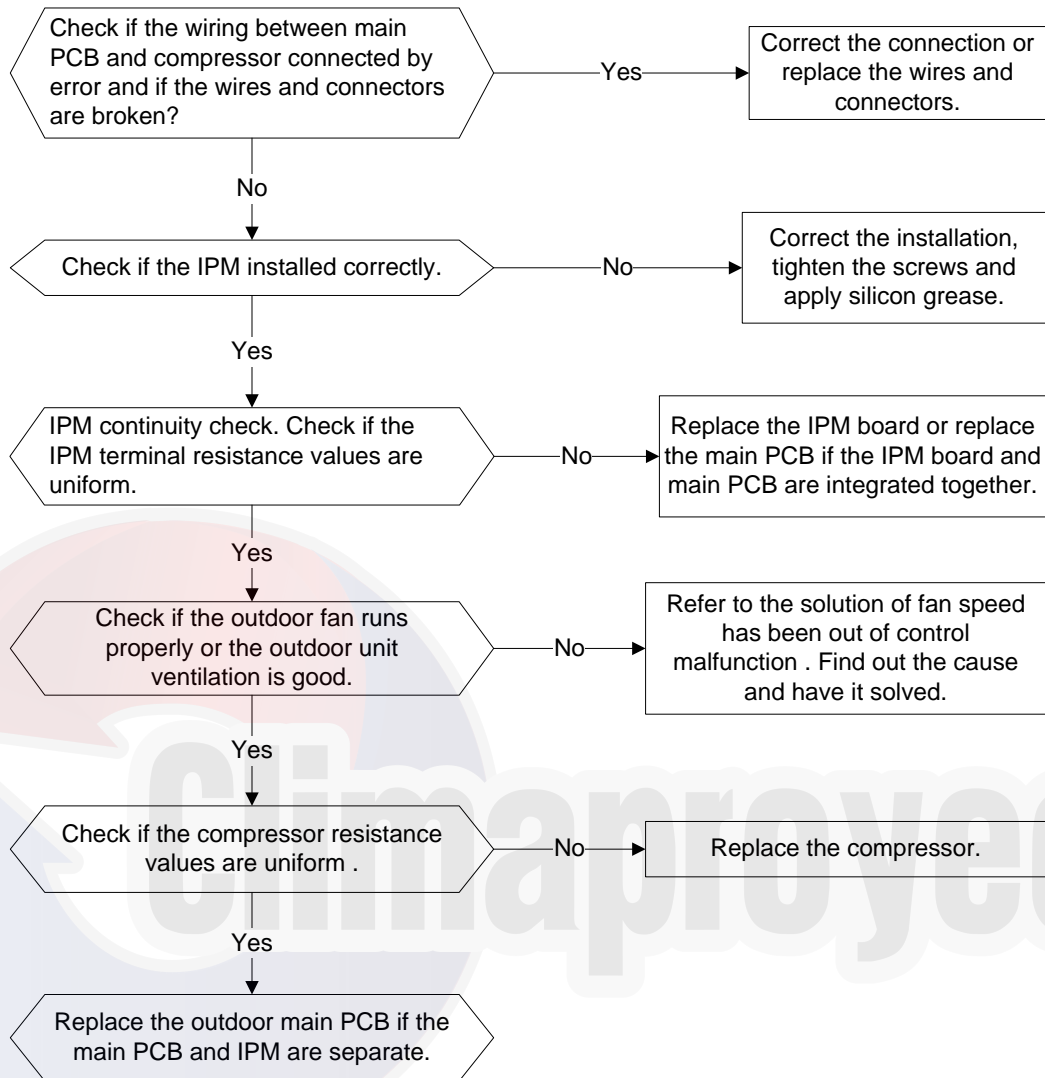

Main parts check

➤ **Temperature sensor checking**

Disconnect the temperature sensor from PCB, measure the resistance value with a tester.

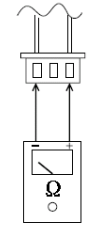

Tester

Temperature Sensors.

- Room temp.(T1) sensor,
- Indoor coil temp.(T2) sensor,
- Outdoor coil temp.(T3) sensor,
- Outdoor ambient temp.(T4) sensor,
- Compressor discharge temp.(T5) sensor.

Measure the resistance value of each winding by using the multi-meter.

Table 1: Some frequently-used R-T data for T1,T2,T3 and T4 sensor:

Temperature (°C)	5	10	15	20	25	30	40	50	60
Resistance Value (KΩ)	26.9	20.7	16.1	12.6	10	8	5.2	3.5	2.4

Table 2: Some frequently-used R-T data for T5 sensor:

Temperature (°C)	5	15	25	35	60	70	80	90	100
Resistance Value (KΩ)	141.6	88	56.1	36.6	13.8	9.7	6.9	5	3.7

Resistance value (KΩ)

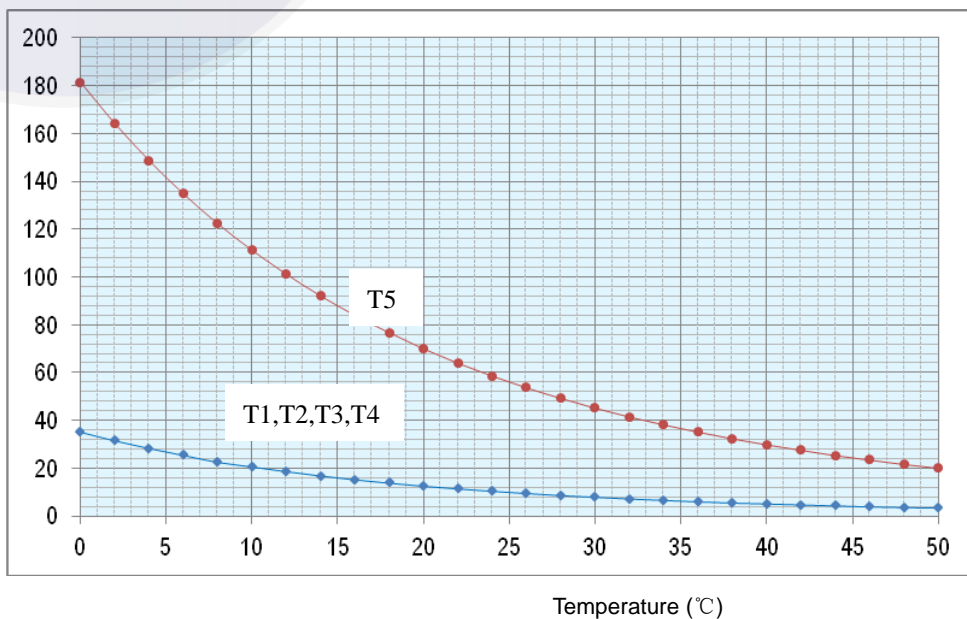



Appendix:

°C	10	11	12	13	14	15	16
F	48	50	52	54	56	58	60
°C	17	18	19	20	21	22	23
F	62	64	66	68	70	72	74
°C	24	25	26	27	28	29	30
F	76	78	80	82	84	86	88
°C	31	32	33	34	35		
F	90	92	94	96	98		

