



# Technical Service Manual

Mini VRF



**Model:**

1 phase, 208-230V, 60Hz

MDV-V105W/DVN1

MDV-V120W/DVN1

MDV-V140W/DVN1

MDV-V160W/DVN1

# Contents

---

001 Part 1 General Information

009 Part 2 Outdoor Units

053 Part 3 Installation



# Part 1 General Information

1. Product Lineup ..... 2

2. Nomenclature..... 3

3. Features..... 4

4. Indoor Units Lineup..... 8



# 1. Product Lineup

## Outdoor Units



**10.5kW Model**



**12~16kW Model**

Model name	Dimension body Inch (mm)	Net/Gross weight lbs(kg)	Power supply
MDV-V105W/DVN1	Width:42-21/64 (1075) Height: 38-1/32(966) Depth: 15-19/32(396)	171.8/187.4(78/85)	208-230V-1ph ~60Hz
MDV-V120W/DVN1	Width:35-7/14 (900) Height: 52-1/4(1327) Depth: 15-3/4(400)	209.4/233.7(95/106)	208-230V-1ph ~60Hz
MDV-V140W/DVN1		209.4/233.7(95/106)	208-230V-1ph ~60Hz
MDV-V160W/DVN1		224.9/249.1(102/113)	208-230V-1ph ~60Hz

## 2. Nomenclature

### MDV-V120W/DVN1

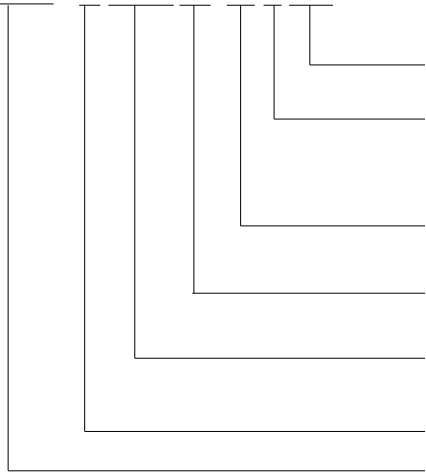
**Refrigerant**

N1:R410A

**Power supply**

V: 208~230V-60Hz-1ph

D: 208~230V, 60Hz, 3ph

C: 380~415V, 60Hz, 3ph

**Inverter Type**

D: DC Inverter

**W: Outdoor unit****Cooling Capacity (X100W)\*****Inverter****Midea VRF**

\*Note: the actual cooling capacity please refers to the nameplate.

**Climaproyectos**  
**.com**

### 3. Features

#### 3.1 Wide application

The All DC Inverter Mini VRF system is a highly efficient solution for small commercial buildings requiring heating and cooling of up to 7 zones with one outdoor unit. Such as villa, restaurant, school etc.

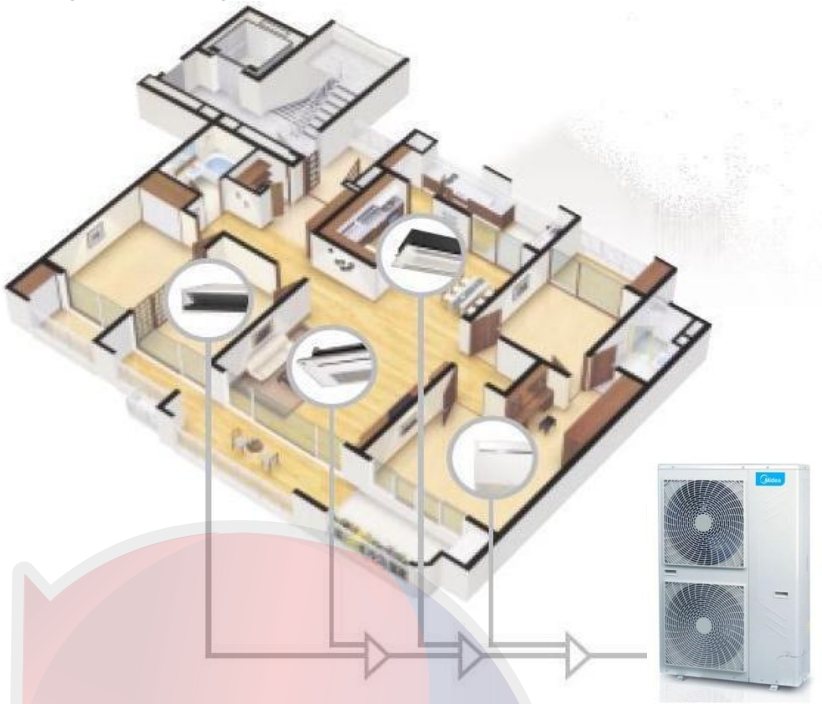

Midea offers a variety of indoor unit, more than 100 models of 15 types. Capacity ranges are from 1.8kW to 16kW. It is full compliance with residential and light commercial place. Our systems can operate up to 130% of capacity which allows any system to be designed to the customers' and applications' needs.



### 3.2 High efficiency DC inverter compressor

All DC inverter Mini VRF adopt highly intelligent inverter-driven compressor. This advanced technology enables the output of the outdoor unit to be modulated by the real heat load demands. This advanced system ensures precise temperature regulation and highly efficient energy usage, making a significant contribution to the limiting the impact on the environment.

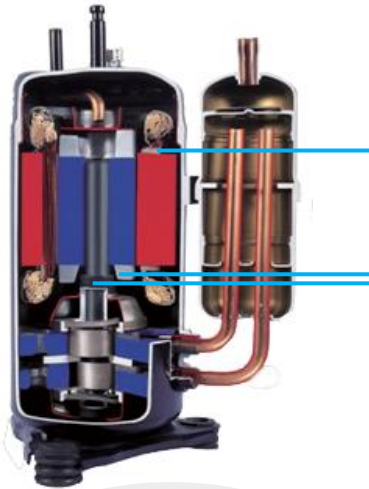

- Highly Efficient DC Motor:**
  - Creative motor core design
  - High density neodymium magnet
  - Concentrated type stator
  - Wider operating frequency range
- Better balance and Extremely Low Vibration:**
  - Twin eccentric cams
  - 2 balance weights
- Highly Stable Moving Parts:**
  - Optimal material matching rollers and vanes
  - Optimize compressor drive technology
  - Highly robust bearings
  - Compact structure

### 3.3 High performance heat exchanger

The new designed window fins enlarge the heat-exchanging area , decrease the air resistance, save more power and enhance heat exchange performance. Hydrophilic film fins and inner-threaded copper pipes optimize heat exchange efficiency.

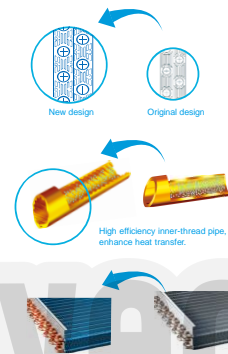

### 3.4 Low-operating sound design

Optimally design fan shape and new designed discharge air grille and air deflector, making higher air volume and lower operation sound.

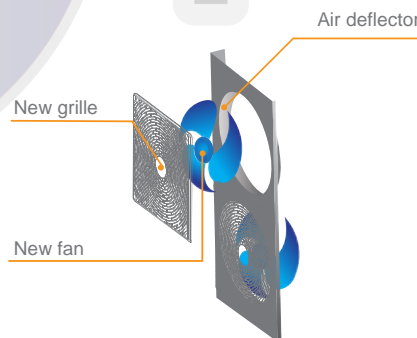

### 3.5 Quick warm-up & cool-down design and less temperature fluctuation

Utilizing the inverter compressor benefits, the system can reach full load quickly and shorten warm-up or cool-down time for an immediate comfortable air solution. Less temperature fluctuation will create a better living environment.

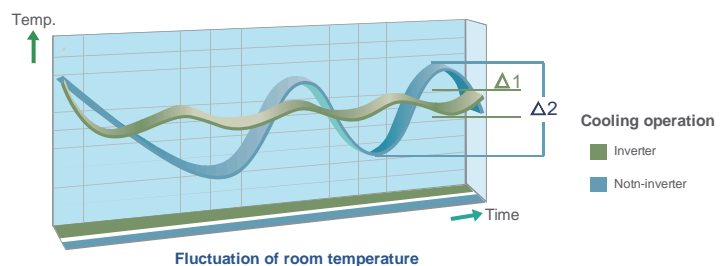

### 3.6 Wide operation temperature range

No matter in extremely cold winter when outdoor temperature gets as low as -15°C or in hot summer when temperature is up to 43°C, the Mini VRF system will keep stable performance.

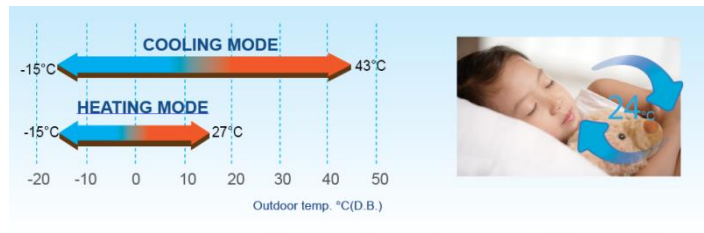

### 3.7 Flexible piping design

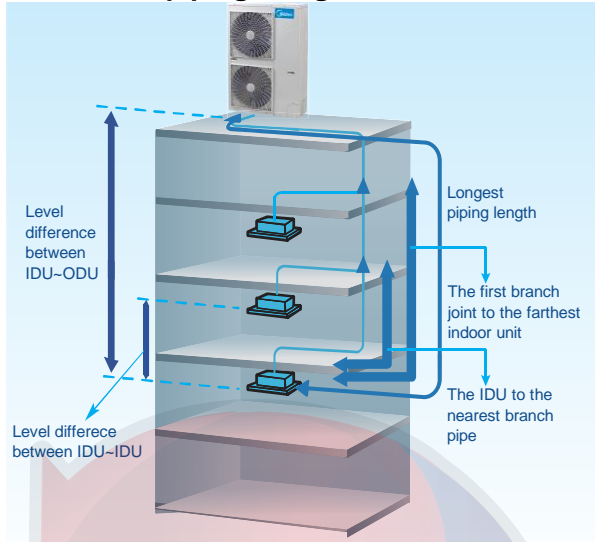

Piping Length		Permitted Value
Total piping length (Actual)		100m
Longest piping length	Actual	45m(10.5kW)
		60m (12~16kW)
	Equivalent	50m(10.5kW)
		70m (12~16kW)
The first branch joint to the farthest IDU		20m
The IDU to the nearest branch pipe		15m
Level difference between ODU~IDU	ODU up	30m
	ODU down	20m
Level difference between IDU~IDU		8m

### 3.8 Flexible indoor unit's connection

Mini VRF with intelligent control gives you independent zoning control with maximum flexibility. A single outdoor unit supports up to nine indoor units, freeing up considerable space outside. Use your backyard more wisely with much more space available created by less number of outdoor units.

- Max. 5 indoor units for a 10.5kW outdoor unit installation
- Max. 6 indoor units for a 12kW outdoor unit installation
- Max. 6 indoor units for a 14kW outdoor unit installation
- Max. 7 indoor units for a 16kW outdoor unit installation

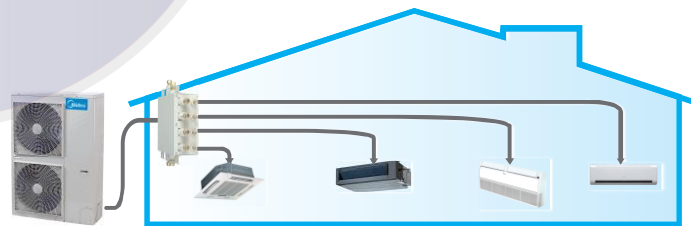

### 3.9 Simple signal line connection

Installation is much easier as the communication wiring between indoor & outdoor units can be shared. It's easy for the user to retrofit the existing system with a centralized control by simply connecting to outdoor units.

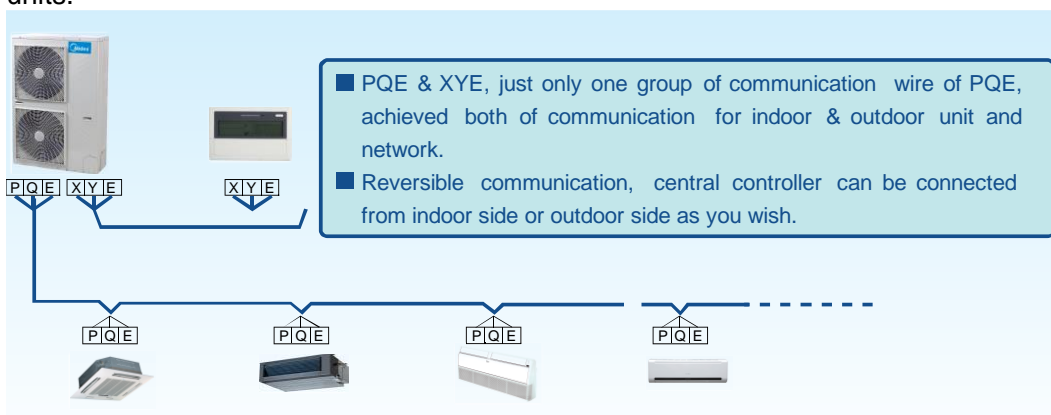



### 3.10 Auto address setting function

The addresses of indoor units can be set automatically by outdoor unit.

Wired controller and wireless controller can enquire and modify the address of each indoor unit.

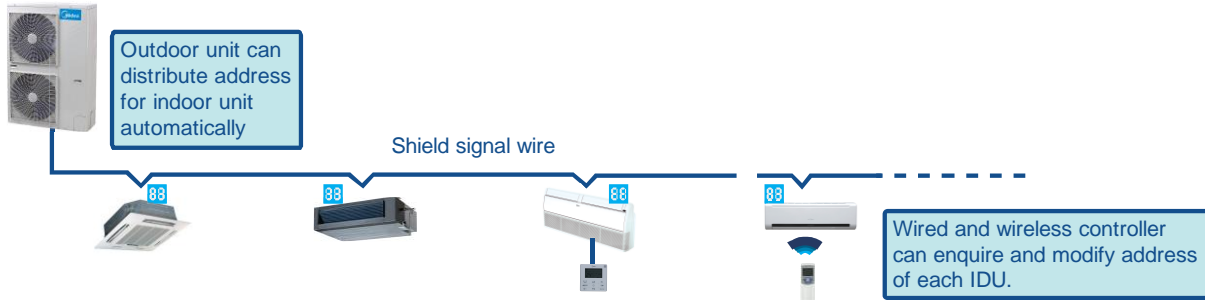

### 3.11 Easy piping connection

Offering four directions to connect pipes and wirings to meet various installation requests.

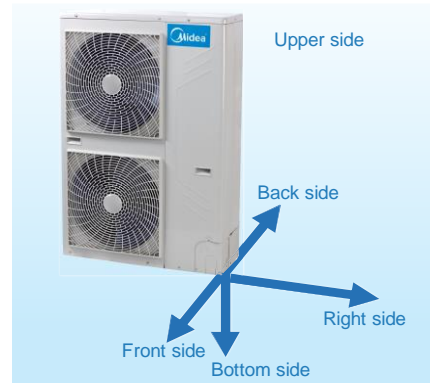
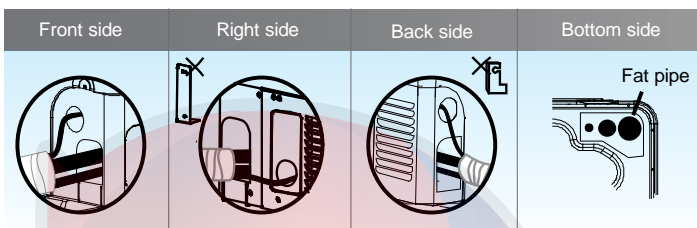

### 3.12 Easy installation

The mini VRF can be transported by elevator which makes installation dramatically easy, and effectively reduces time and labor thanks to the small size.

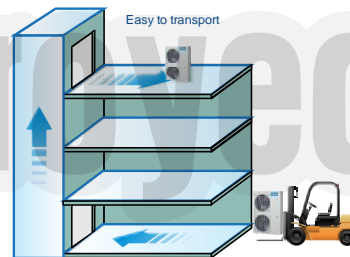

### 3.13 Easy maintenance

Forced cooling button makes outdoor unit run in cooling mode at any condition, so it is very easy for you to charge refrigerant to the system when it needs to be done. The self-diagnosis function detects malfunctions in major locations in the system and displays the type of malfunction and location. This allows service and maintenance to be performed more efficiently.

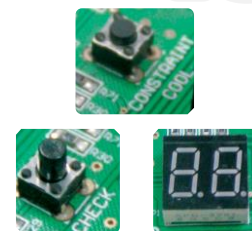





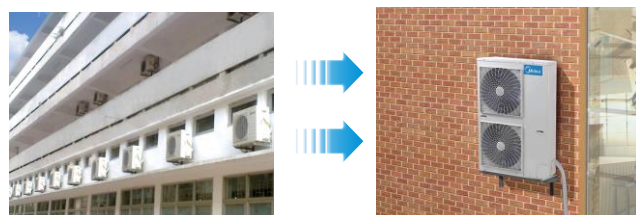



### 3.14 Space saving



The Mini VRF units are more compact, resulting in significant savings in installation space. It is particularly suitable for small offices, villas, shops, etc.

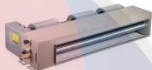

### 4. Indoor Units Lineup

Capacity (x100W)	Capacity (Btu/h)	Cassette type			
		One-way cassette	Two-way cassette	Compact four-way cassette	Four-way cassette
					
18	6140	•			
22	7500	•	•	•	
28	9600	•	•	•	•
36	12300	•	•	•	•
45	15400	•	•	•	•
56	19100	•	•		•
71	24200	•	•		•
80	27300				•
90	30700				•
100	34100				•
112	38200				•
140	42600				•

Capacity (x100W)	Capacity (Btu/h)	Duct type			
		Low static pressure duct	Medium static pressure duct	High static pressure duct	
					
18	6140	•			
22	7500	•	•		
28	9600	•	•		
36	12300	•	•		
45	15400	•	•		
56	19100	•	•		
71	24200		•	•	
80	27300		•	•	
90	30700		•	•	
100	34100			•	
112	38200		•	•	
140	42600		•		
160	54600				•

Capacity (x100W)	Capacity (Btu/h)	Wall mounted			Ceiling & Floor
		S panel	M panel	R panel	
					
22	7500	•	•		
28	9600	•	•		
36	12300	•	•		•
45	15400	•	•		•
56	19100	•	•		•
71	24200		•	•	•
80	27300		•	•	•
90	30700		•	•	•
112	34100				•
140	38200				•
160	42600				•

**Note:** If ODU connect only one IDU, the capacity of IDU should be not more than ODU.  
 If ODU connect more than one IDU, the capacity of each IDU should be not more than 8kW for refrigerant uniform distribution.  
 Due to continuous improvement, specifications are subject to change without prior notice.

# Part 2 Outdoor Units

- 1. Specifications ..... 10
- 2. Dimensions ..... 13
- 3. Service Space ..... 14
- 4. Piping Diagrams ..... 15
- 5. Wiring Diagrams ..... 16
- 6. Capacity Tables ..... 19
- 7. Electric Characteristics ..... 51
- 8. Sound Levels ..... 51
- 9. Operation Limits ..... 52



# 1. Specifications

Sale Model			MDV-V105W/DVN1	MDV-V120W/DVN1	
Code			220095103400	220095101900	
Power supply		V-Ph-Hz	208-230V-1Ph~60Hz	208-230V-1Ph~60Hz	
Cooling	Capacity	kW	10.5	12	
		Btu/h	35800	40900	
	Input	kW	2.68	3.25	
Heating	Capacity	kW	11.5	13.2	
		Btu/h	39200	45000	
	Input	kW	2.9	3.47	
Compressor	Model		TNB220FLHMC	TNB306FPGMC	
	Type		Rotary	Rotary	
	Brand		MITSUBISHI	MITSUBISHI	
	Capacity	Btu/h	24330	33710	
	Input	W	2200	3010	
	Rated current(RLA)	A	9.7	13.5	
	Crankcase	W	25	27	
	Refrigerant oil	gal(ml)	FV50S 0.053+0.177(200+670)	FV50S 0.230+0.166(870+630)	
Outdoor fan motor	Model		WZDK170-38G-1	WZDK100-38G	
	Type		DC motor	DC motor	
	Brand		Panasonic	Panasonic	
	Insulation class		E	E	
	Safe class		IP23	IP23	
	Input	W	200	2 x 100	
	Output	W	170	2 x 85	
	Rated current	A	1.6	2 x 0.9	
	Capacitor	uF	/	/	
	Speed	r/min	820	800	
Outdoor fan	Material		ASG20	ASG20	
	Type		Axial fan	Axial fan	
	Diameter	in.(mm)	(22)560	20(508)	
	Height	in.(mm)	6-11/16(170)	6-11/16(170)	
Outdoor coil	Number of rows		2	2	
	Tube pitch(a)x row pitch(b)	in.(mm)	55/64 x 3/4(22 x19.05)	7/8 x3/4 (22 x 19.05)	
	Fin spacing	in.(mm)	1/16(1.6)	1/16(1.6)	
	Fin type (code)		Hydrophilic aluminum		
	Tube outside dia.and type	in.(mm)		5/16(Φ7.94)	5/16(Φ7.94)
				Inner groove tube	Inner groove tube
	Coil length x height	in.(mm)	34-27/32 x 34-41/64(885 x 880)	50-1/4 x 34-1/4(1276 x 870)	
Number of circuits		6	7		
Outdoor air flow	CFM(m <sup>3</sup> /h)	3000(5100)	3531(6000)		

Sale Model			MDV-V105W/DVN1	MDV-V120W/DVN1
Code			220095103400	220095101900
Outdoor sound level(sound pressure level )		dB(A)	57	57
Outdoor unit	Dimension (W x H x D)	in.(mm)	42-21/64 x38-1/32 x15-19/32 (1075x966x396)	35-7/14x52-1/4x15-3/4 (900x1327x400)
	Packing (W x H x D)	in.(mm)	44-3/32 x43-5/16 x17-1/8 (1120x1100x435)	40-9/16x57-5/16x17-1/8 (1030x1456x435)
	Net/Gross weight	Lbs(kg)	171.9/187.3(78/85)	209.4/233.7 (95/106)
Refrigerant	Type		R410a	R410A
	Charged volume	Lbs(kg)	6.6(3.0)	7.3(3.3)
Throttle type			Electronic expansion valve	
Design pressure		MPa	4.4/2.6	
Refrigerant piping	Liquid side	in.(mm)	Φ3/8(Φ9.53)	Φ3/8(Φ9.53)
	Gas side	in.(mm)	Φ5/8(Φ15.9)	Φ5/8(Φ15.9)
	Max. refrigerant pipe length	ft.(m)	328(100)	328(100)
	Max. difference in level	ft.(m)	26(8)	26(8)
Connection wiring	Power wiring	mm <sup>2</sup>	3 core x 4.0	3 core x 4.0
	Signal wiring	mm <sup>2</sup>	3 core shielded wire x 0.75	3 core shielded wire x 0.75
Ambient temperature		°F(°C)	Cooling 5~109.4°F (-15~43°C) Heating 5~80.6°F (-15~27°C)	

Model			MDV-V140W/DVN1	MDV-V160W/DVN1
Code			220095101890	220095102980
Power supply		V-Ph-Hz	208-230V-1Ph~60Hz	208-230V-1Ph~60Hz
Cooling	Capacity	kW	14	15.5
		Btu/h	47800	52900
	Input	kW	3.95	4.52
Heating	Capacity	kW	15.4	17
		Btu/h	52500	58020
	Input	kW	4.16	4.77
Compressor	Model		TNB306FPGMC	LNB42FSCMC
	Type		Rotary	Rotary
	Brand		MITSUBISHI	MITSUBISHI
	Capacity	Btu/h	33710	47713
	Input	W	3010	14573
	Rated current(RLA)	A	13.5	24
	Crankcase	W	25	20
	Refrigerant oil	gal(ml)	FV50S 0.230+0.166 (870+630)	FV50S 0.36+0.05(1400+250)
Outdoor fan motor	Model		WZDK100-38G	WZDK100-38G
	Type		DC motor	DC motor
	Brand		Panasonic	Panasonic
	Insulation class		E	E
	Safe class		IP23	IP23
	Input	W	2 x 100	2 x 100
	Output	W	2 x 85	2 x 85
	Rated current	A	2 x 0.9	2 x 0.9

Model			MDV-V140W/DVN1	MDV-V160W/DVN1
Code			220095101890	220095102980
Outdoor fan motor	Capacitor	uF	/	/
	Speed	r/min	800	800
Outdoor fan	Material		ASG20	ASG20
	Type		Axial fan	Axial fan
	Diameter	in.(mm)	20(508)	20(508)
	Height	in.(mm)	6-11/16(170)	6-11/16(170)
Outdoor coil	Number of rows		2	2
	Tube pitch(a)x row pitch(b)	in.(mm)	7/8 x3/4 (22 x 19.05)	7/8 x3/4 (22 x 19.05)
	Fin spacing	in.(mm)	1/16(1.6)	1/16(1.6)
	Fin type (code)		Hydrophilic aluminum	Hydrophilic aluminum
	Tube outside dia.and type	in.(mm)	5/16(Φ7.94)	5/16(Φ7.94)
			Inner groove tube	Inner groove tube
	Coil length x height	in.(mm)	50-1/4 x 34-1/4(1276 x 870)	50-1/4 x 34-1/4(1276 x 870)
Number of circuits		7	7	
Outdoor air flow		CFM(m <sup>3</sup> /h)	3531(6000)	3531(6000)
Outdoor sound level(sound pressure level )		dB(A)	57	57
Outdoor unit	Dimension (W x H x D)	in.(mm)	35-7/14x52-1/4x 15-3/4(900x1327x400)	
	Packing (W x H x D)	in.(mm)	40-35/64 x 57-21/64 x 17-1/8(1030 x1456 x435)	
	Net/Gross weight	Lbs(kg)	209.4/233.7 (95/106)	224.9/249.1(102/113)
Refrigerant	Type		R410A	R410A
	Charged volume	Lbs(kg)	8.6 (3.9)	8.6 (3.9)
Throttle type			Electronic expansion valve	
Design pressure		MPa	4.4/2.6	
Refrigerant piping	Liquid side	in.(mm)	Φ3/8(Φ9.53)	Φ3/8(Φ9.53)
	Gas side	in.(mm)	Φ5/8(Φ15.9)	Φ3/4(Φ19.1)
	Max. refrigerant pipe length	ft.(m)	328(100)	328(100)
	Max. difference in level	ft.(m)	26(8)	26(8)
Connection wiring	Power wiring	mm <sup>2</sup>	3 core x 4.0	3 core x 4.0
	Signal wiring	mm <sup>2</sup>	3 core shielded wire x 0.75	3 core shielded wire x 0.75
Ambient temperature		°F(°C)	Cooling 5~109.4°F (-15~43°C) Heating 5~80.6°F (-15~27°C)	

**Notes:**

- The cooling conditions: indoor temp.: 27°CDB (80.6°F), 19°CWB (66.2°F) outdoor temp.: 35°CDB (95°F) equivalent pipe length: 5m drop length: 0m.
- The heating conditions: indoor temp.: 20°CDB (68°F), 15°CWB (44.6°F) outdoor temp.: 7°CDB (42.8°F) equivalent pipe length: 5m drop length: 0m.
- Sound level: Anechoic chamber conversion value, measured at a point 3.28ft (1.0m) in front of the unit at a height of \*m (1m (3.28ft.)for 105 model,1.2m(3.94ft.) for 120~160 model ). During actual operation, these values are normally somewhat higher as a result of ambient conditions.
- The above data may be changed without notice for future improvement on quality and performance.

## 2. Dimensions

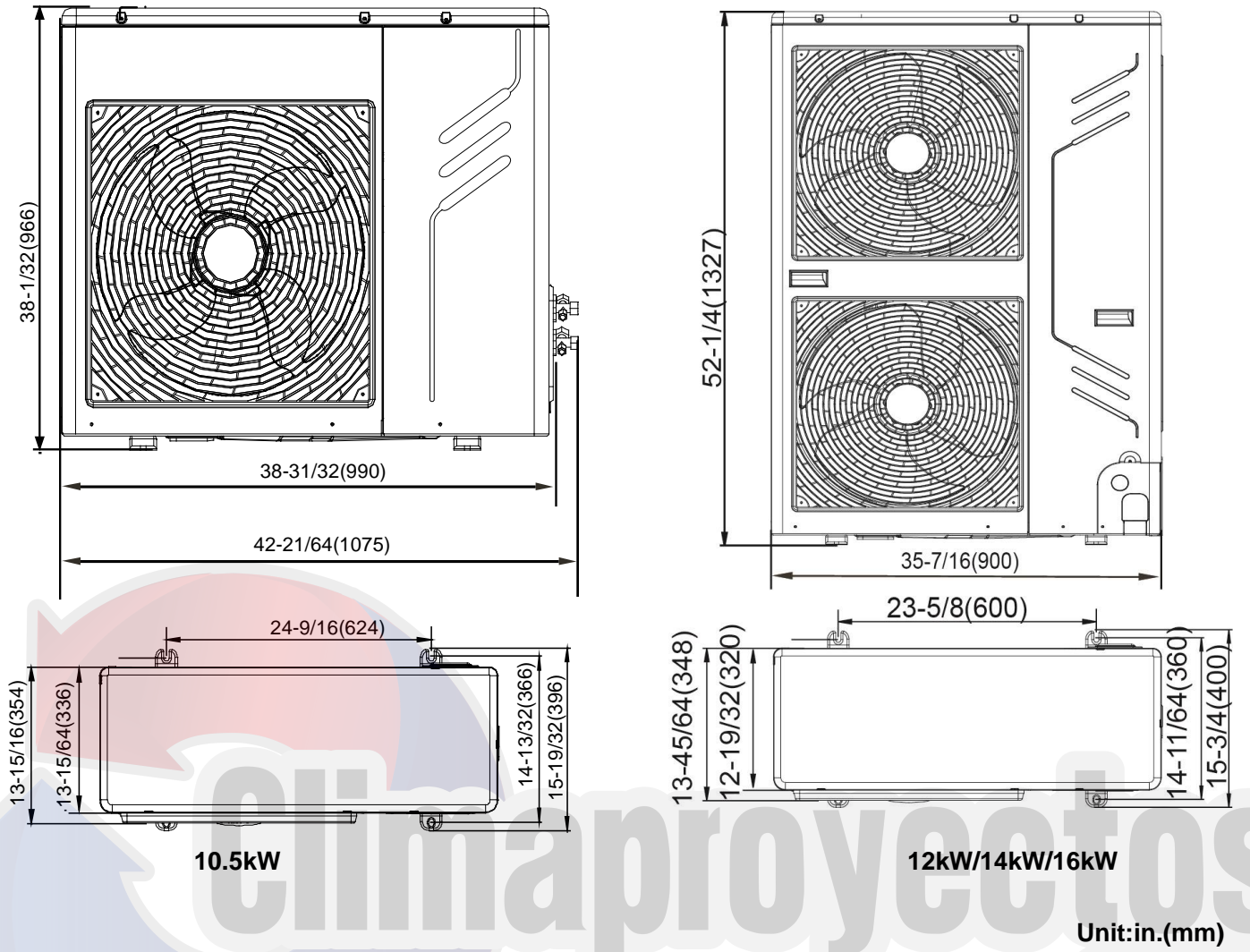

### 3. Service Space

- Single unit installation

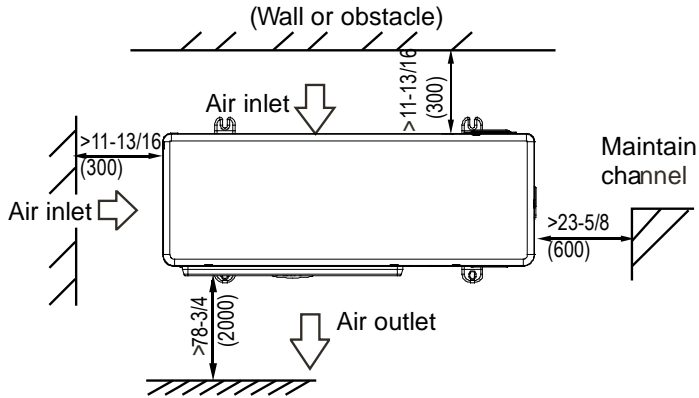

- Parallel connect the two units or above

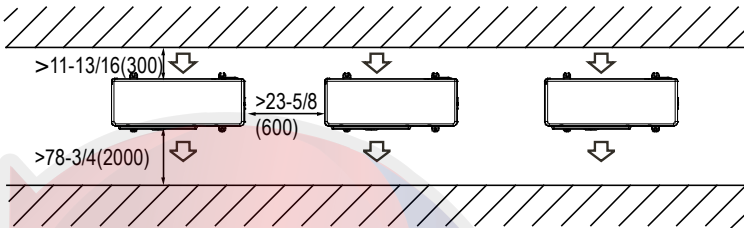

- Parallel connect the front with rear sides

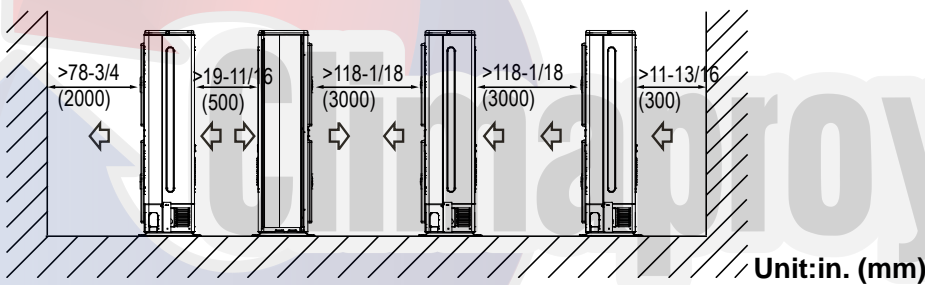



### 4. Piping Diagrams

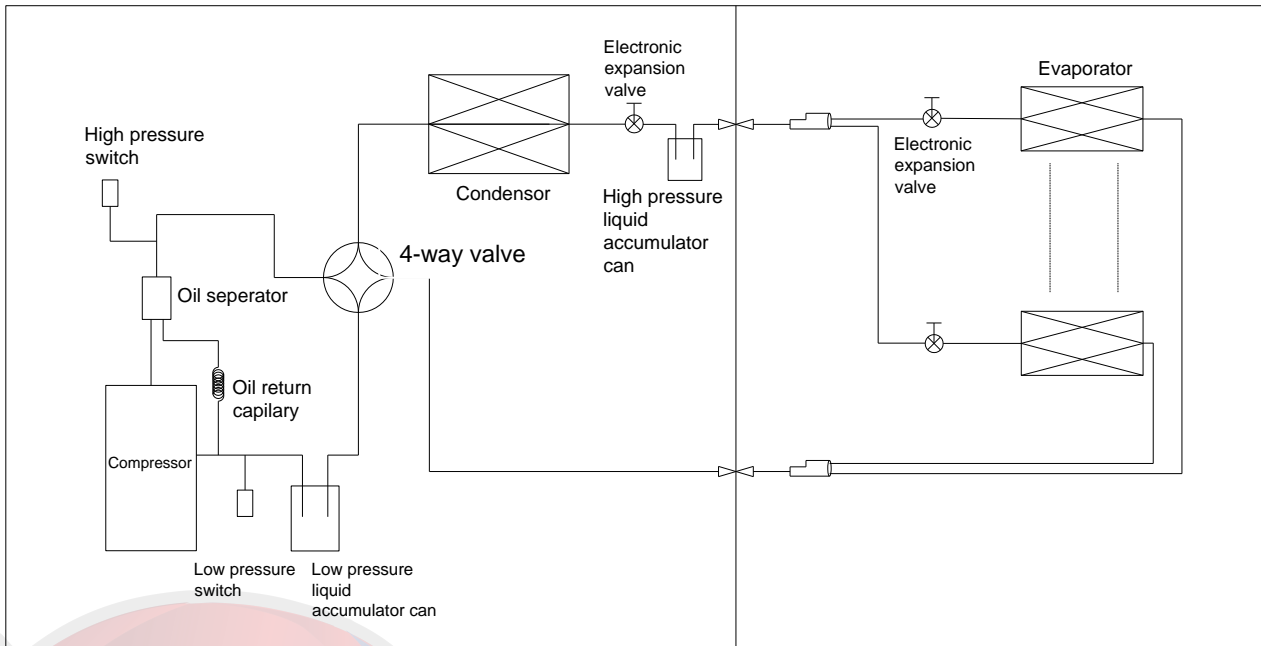

**Oil separator:** used to separate oil from high pressure & temperature gas refrigerant, which is pumped out from compressor. It makes the oil return back to each compressor very soon.

**Low pressure liquid receiver & High pressure liquid receiver:** It is used to store the liquid refrigerant and oil; it can protect the compressor from liquid hammer.

**4-way valve:** Closed in cooling mode and open in heating mode

**Electronic expansion valve:** The opening is of the valve is regulated according to the discharge air temperature of compressor, used to regulating refrigerant flow.

**High Pressure Switch:** When the discharge pressure of compressor is 4.2Mpa or higher, the protection switch will be triggered, and if the discharge pressure is down to 3.3MPa, the protection switch will be recovered.

**Low Pressure Switch:** When the gas pressure back to compressor is 0.14Mpa or lower, the protection switch will be triggered, and if the discharge pressure is down to 0.3MPa, the protection switch will be recovered.

# 5. Wiring Diagrams

10.5kW

CODE	PART NAME
COMP.	COMPRESSOR
CAP1	CAPACITANCE
CT1	AC CURRENT DETECTOR
EEV.	ELECTRIC EXPANSIVE VALVE
FAN1	OUTDOOR FAN MOTOR
HEAT	CRANKCASE HEATING
H-PRO	HIGH PRESSURE SWITCH
L-PRO	LOW PRESSURE SWITCH
L	PFC INDUCTANCE
D1	RECTIFIER
R1	RESISTANCE
4-WAY	4-WAY VALVE
T3	CONDENSER TEMPERATURE SENSOR
T4	OUTDOOR AMBIENT TEMPERATURE SENSOR
T5	COMP. DISCHARGE TEMPERATURE SENSOR
XT1	3-WAY TERMINAL
XT2	6-WAY TERMINAL

Display	Malfunction or Protection
E0	EEPROM malfunction
E2	Communication malfunction between indoor/outdoor units
E3	Communication malfunction between R321/outdoor units
E4	T3874 temperature sensor malfunction
E5	Voltage protection
E6	Dc fan motor malfunction
E7	A fan in the A region run for more than 5 minutes in Heat mode
E8	2 times of B protection in 10 minutes
P1	High pressure protection
P2	Low pressure protection
P3	Outdoor input current protection
P4	Compressor discharge temperature protection
P5	Condenser high temperature protection
P6	IPM protection
P7	Evaporator high temperature protection
P8	Typhoon protection

SW3	
ON	Obtain net address automatically
OFF	Obtain net address manually
ON	Reversion indoor unit net address
OFF	Undefined

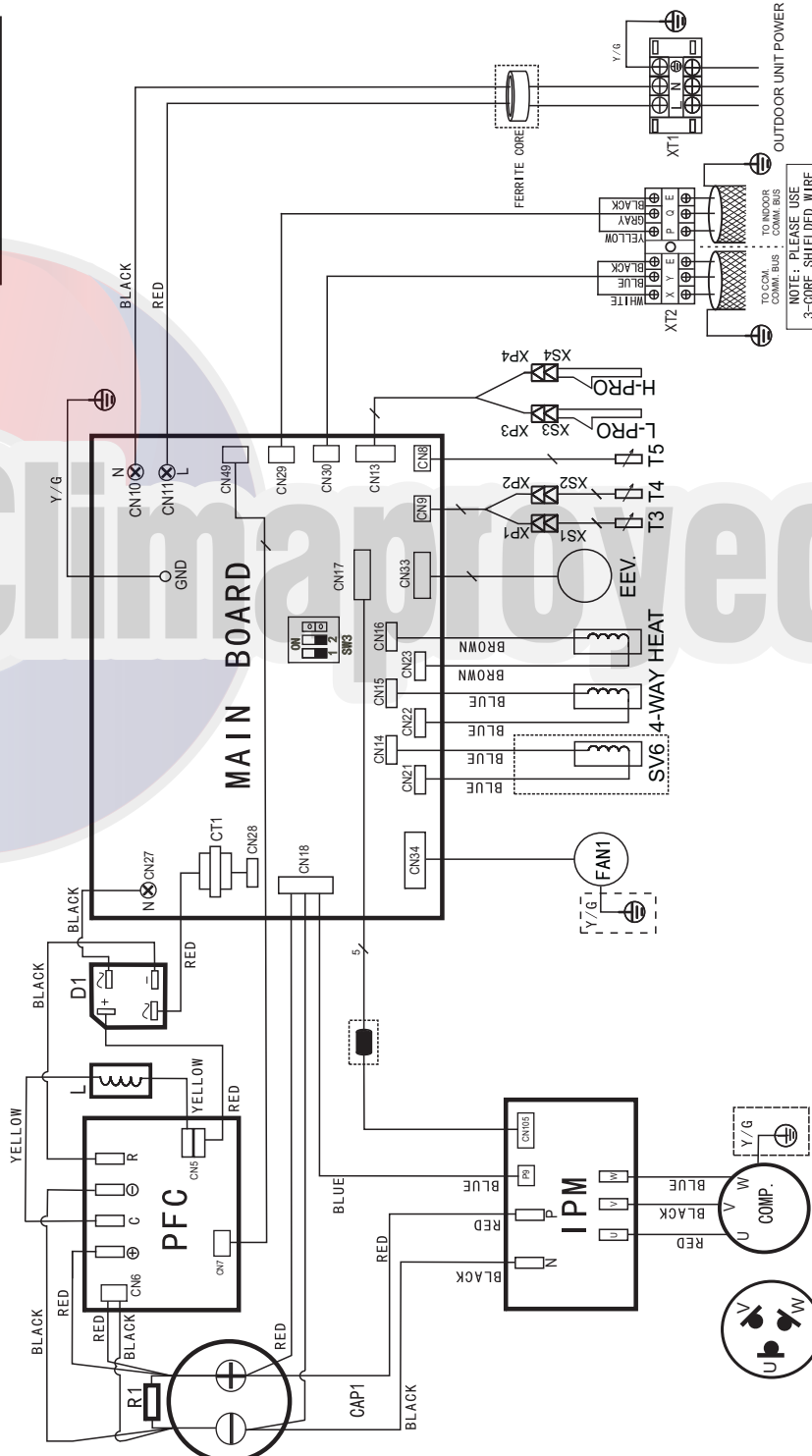

12-16kW

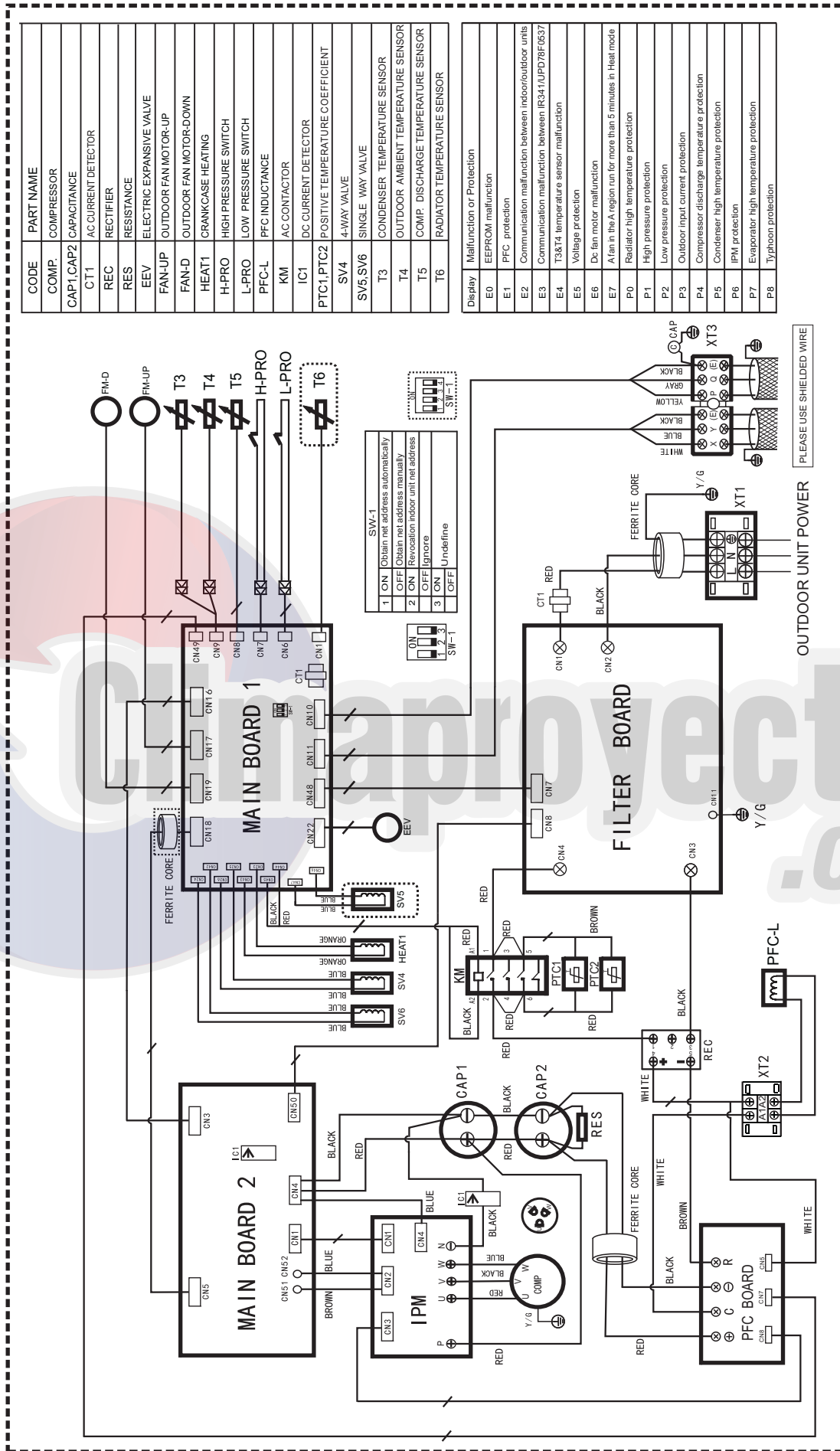

### 6. Field Wiring

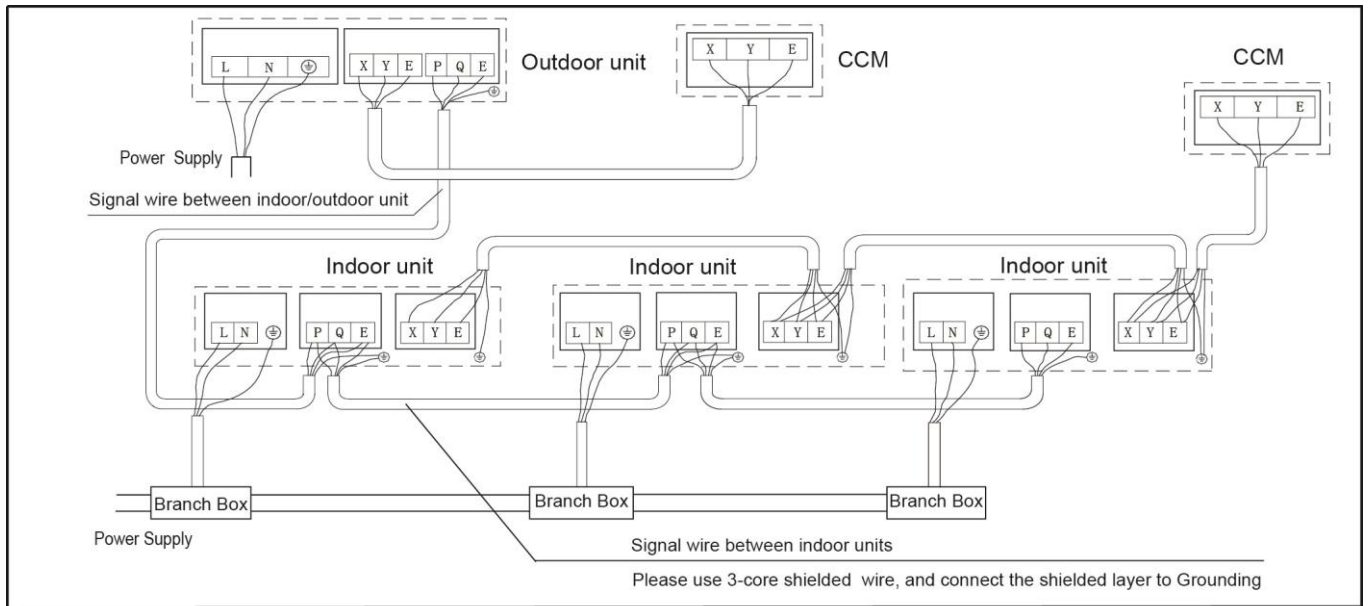

For 8~16kw(1-Phase)

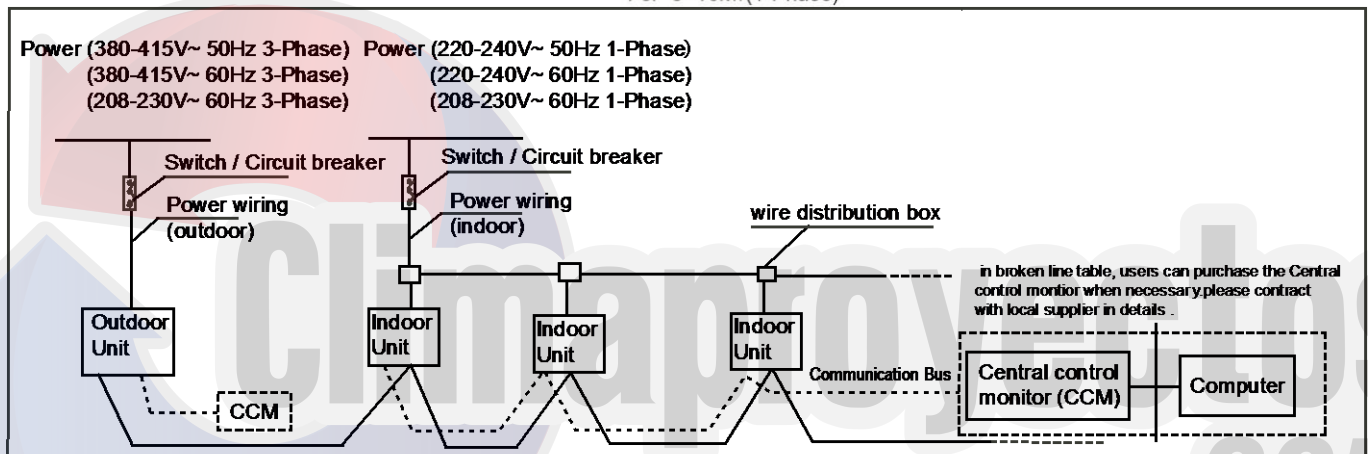

For 10.5~18kw

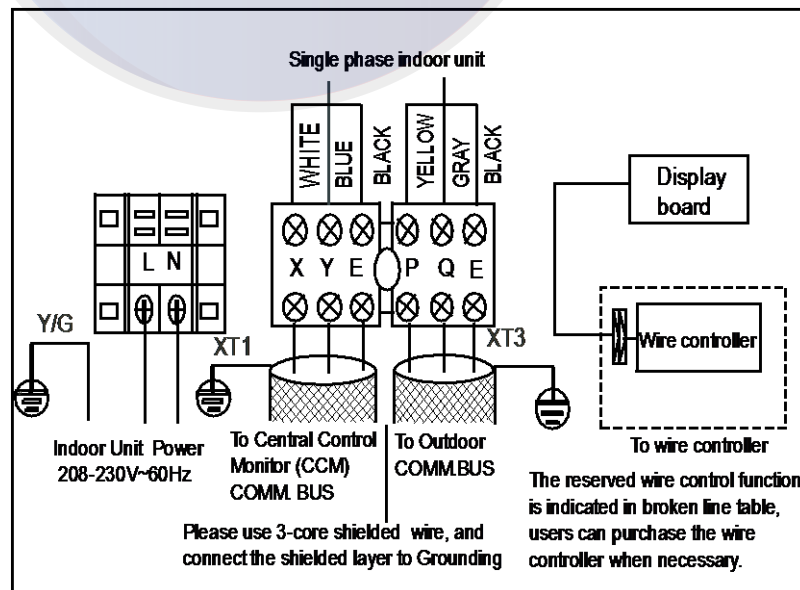

# 7. Capacity Tables

## MDV-V105W/DVN1

### Cooling

Combination (%) (Capacity index)	Outdoor temperature (°F DB)	Indoor temperature(°FDB/WB)													
		DB:69.4,WB:57.2		DB:73.9,WB:60.8		DB:78.4,WB:64.4		DB:80.6,WB:66.2		DB:82.7,WB:68		DB:87.3,WB:71.6		DB:89.6,WB:75.2	
		TC	PI	TC	PI	TC	PI	TC	PI	TC	PI	TC	PI	TC	PI
		kW	kW	kW	kW	kW	kW	kW	kW	kW	kW	kW	kW	kW	kW
130%	23	9.22	1.1	10.99	1.34	12.75	1.43	13.24	1.49	13.87	1.53	14.21	1.67	14.57	1.68
	28.4	9.22	1.1	10.99	1.36	12.75	1.43	13.24	1.5	13.87	1.53	14.21	1.69	14.57	1.7
	32	9.22	1.11	10.99	1.39	12.75	1.49	13.24	1.58	13.87	1.62	14.21	1.71	14.57	1.72
	35.6	9.22	1.13	10.99	1.39	12.75	1.54	13.24	1.67	13.87	1.64	14.21	1.72	14.57	1.74
	39.2	9.22	1.16	10.99	1.42	12.75	1.59	13.24	1.68	13.87	1.66	14.21	1.72	14.57	1.78
	42.8	9.22	1.18	10.99	1.44	12.75	1.65	13.24	1.69	13.72	1.71	14.04	1.72	14.41	1.79
	46.4	9.22	1.21	10.99	1.48	12.75	1.73	13.24	1.78	13.55	1.77	13.89	3.9	14.23	1.81
	50	9.22	1.24	10.99	1.51	12.75	1.8	13.24	1.84	13.39	4.04	13.72	4.06	14.06	1.86
	53.6	9.22	1.26	10.99	1.54	12.75	1.83	13.05	4.03	13.24	4.06	13.54	4.07	13.87	1.87
	57.2	9.22	1.28	10.99	1.57	12.71	4.05	12.9	4.06	13.05	4.08	13.39	4.09	13.72	1.91
	60.8	9.22	1.3	10.99	1.6	12.56	4.06	12.71	4.08	12.86	4.1	13.2	4.12	13.54	1.94
	64.4	9.22	1.33	10.99	1.63	12.37	1.91	12.52	1.93	12.71	1.94	13.05	1.95	13.39	1.97
	68	9.22	1.36	10.99	1.74	12.19	2.01	12.37	2.02	12.52	2.03	12.86	2.05	13.2	2.07
	69.8	9.22	1.39	10.99	1.8	12.11	2.06	12.3	2.07	12.45	2.08	12.79	2.1	13.12	2.12
	73.4	9.22	1.5	10.99	1.93	11.96	2.15	12.11	2.16	12.26	2.17	12.6	2.19	12.94	2.21
	77	9.22	1.6	10.99	2.07	11.77	2.24	11.92	2.25	12.11	2.27	12.45	2.29	12.79	2.31
	80.6	9.22	1.7	10.99	2.21	11.62	2.34	11.77	2.35	11.92	2.36	12.26	2.39	12.6	2.41
	84.2	9.22	1.82	10.99	2.36	11.44	2.43	11.59	2.45	11.77	2.46	12.11	2.49	12.45	2.51
	87.8	9.22	1.94	10.95	2.5	11.25	2.53	11.44	2.54	11.59	2.55	11.92	2.58	12.26	2.61
	91.4	9.22	2.07	10.76	2.59	11.1	2.62	11.25	2.64	11.44	2.65	11.77	2.68	12.07	2.71
95	9.22	2.21	10.57	2.69	10.91	2.72	11.1	2.73	11.25	2.75	11.59	2.78	11.92	2.81	
98.6	9.22	2.35	10.42	2.78	10.76	2.82	10.91	2.83	11.1	2.85	11.4	2.88	11.74	2.92	
102.2	9.22	2.5	10.24	2.81	10.57	2.91	10.76	2.93	10.91	2.95	11.25	2.98	11.59	3.02	
105.8	9.22	2.63	10.13	2.84	10.46	2.94	10.65	2.96	10.8	2.97	11.14	2.99	11.14	3.04	
109.4	9.22	2.7	10.06	2.85	10.41	2.95	10.6	2.97	10.69	2.98	10.94	2.99	11.01	3.05	
120%	23	8.51	1.06	10.12	1.28	11.78	1.52	12.6	1.65	13.2	1.72	13.5	1.78	13.8	1.83
	28.4	8.51	1.07	10.12	1.3	11.78	1.53	12.6	1.66	13.2	1.74	13.5	1.79	13.8	1.83
	32	8.51	1.08	10.12	1.3	11.78	1.55	12.6	1.67	13.2	1.76	13.5	1.8	13.8	1.84
	35.6	8.51	1.08	10.12	1.32	11.78	1.56	12.6	1.68	13.2	1.77	13.5	1.82	13.8	1.84
	39.2	8.51	1.09	10.12	1.33	11.78	1.58	12.6	1.7	13.2	1.79	13.5	1.82	13.8	1.84
	42.8	8.51	1.1	10.12	1.34	11.78	1.6	12.6	1.72	13.2	1.81	13.5	1.84	13.8	1.85
	46.4	8.51	1.11	10.12	1.36	11.78	1.62	12.6	1.74	13.2	1.83	13.5	1.84	13.8	1.86
	50	8.51	1.13	10.12	1.38	11.78	1.64	12.6	1.77	13.2	1.83	13.5	1.85	13.8	1.87
	53.6	8.51	1.15	10.12	1.4	11.78	1.67	12.6	1.8	13.01	1.84	13.31	1.84	13.61	1.88
	57.2	8.51	1.17	10.12	1.43	11.78	1.7	12.6	1.84	12.82	1.85	13.16	1.86	13.46	1.9
	60.8	8.51	1.19	10.12	1.46	11.78	1.73	12.52	4.1	12.67	1.87	12.97	1.9	13.27	1.93
	64.4	8.51	1.21	10.12	1.49	11.78	1.79	12.34	1.91	12.49	1.92	12.79	1.94	13.12	1.96
	68	8.51	1.24	10.12	1.55	11.78	1.93	12.19	2.01	12.34	2.02	12.64	2.03	12.94	2.05
	69.8	8.51	1.25	10.12	1.6	11.78	2	12.07	2.06	12.22	2.06	12.56	2.08	12.86	2.1
	73.4	8.51	1.34	10.12	1.72	11.78	2.14	11.93	2.15	12.07	2.16	12.37	2.18	12.67	2.2
	77	8.51	1.43	10.12	1.83	11.59	2.23	11.74	2.24	11.89	2.25	12.22	2.27	12.52	2.29
	80.6	8.51	1.52	10.12	1.96	11.44	2.32	11.59	2.34	11.74	2.35	12.04	2.37	12.34	2.39
	84.2	8.51	1.63	10.12	2.09	11.25	2.42	11.4	2.43	11.55	2.44	11.85	2.47	12.19	2.49
	87.8	8.51	1.73	10.12	2.24	11.06	2.51	11.25	2.52	11.4	2.54	11.7	2.56	12	2.59
	91.4	8.51	1.85	10.12	2.38	10.91	2.61	11.06	2.62	11.21	2.63	11.51	2.66	11.81	2.69
95	8.51	1.96	10.12	2.54	10.72	2.7	10.87	2.72	11.06	2.73	11.36	2.76	11.66	2.79	
98.6	8.51	2.09	10.12	2.71	10.57	2.8	10.72	2.81	10.87	2.83	11.17	2.86	11.48	2.89	
102.2	8.51	2.22	10.09	2.86	10.39	2.89	10.54	2.91	10.69	2.93	11.02	2.96	11.33	2.99	
105.8	8.51	2.29	10.01	2.88	10.31	2.91	10.46	2.93	10.61	2.95	10.94	2.97	11	3.01	
109.4	8.51	2.32	9.95	2.9	10.22	2.93	10.37	2.94	10.52	2.96	10.75	2.97	10.83	3.07	

**MDV-V105W/DVN1**  
**Cooling**

Combination (%) (Capacity index)	Outdoor temperature (°F DB)	Indoor temperature(°FDB/WB)													
		DB:69.4,WB:57.2		DB:73.9,WB:60.8		DB:78.4,WB:64.4		DB:80.6,WB:66.2		DB:82.7,WB:68		DB:87.3,WB:71.6		DB:89.6,WB:75.2	
		TC	PI	TC	PI	TC	PI	TC	PI	TC	PI	TC	PI	TC	PI
		kW	kW	kW	kW	kW	kW	kW	kW	kW	kW	kW	kW	kW	kW
110%	23	7.8	0.92	9.3	1.15	10.8	1.37	11.55	1.47	12.3	1.59	13.24	1.65	13.54	1.7
	28.4	7.8	0.94	9.3	1.17	10.8	1.38	11.55	1.49	12.3	1.6	13.24	1.66	13.54	1.71
	32	7.8	0.95	9.3	1.17	10.8	1.39	11.55	1.5	12.3	1.62	13.24	1.68	13.54	1.73
	35.6	7.8	0.97	9.3	1.18	10.8	1.42	11.55	1.51	12.3	1.63	13.24	1.7	13.54	1.75
	39.2	7.8	0.99	9.3	1.2	10.8	1.43	11.55	1.53	12.3	1.66	13.24	1.73	13.54	1.76
	42.8	7.8	1	9.3	1.21	10.8	1.44	11.55	1.56	12.3	1.68	13.24	1.74	13.54	1.79
	46.4	7.8	1.01	9.3	1.23	10.8	1.46	11.55	1.57	12.3	1.7	13.24	1.76	13.54	1.81
	50	7.8	1.02	9.3	1.25	10.8	1.48	11.55	1.6	12.3	1.72	13.24	1.77	13.54	1.83
	53.6	7.8	1.04	9.3	1.27	10.8	1.51	11.55	1.63	12.3	1.76	13.09	1.8	13.35	1.85
	57.2	7.8	1.06	9.3	1.29	10.8	1.54	11.55	1.66	12.3	1.79	12.9	1.81	13.2	1.86
	60.8	7.8	1.08	9.3	1.32	10.8	1.57	11.55	1.69	12.3	1.82	12.75	1.83	13.01	1.88
	64.4	7.8	1.1	9.3	1.34	10.8	1.6	11.55	1.74	12.3	1.91	12.56	1.93	12.86	1.94
	68	7.8	1.12	9.3	1.37	10.8	1.69	11.55	1.87	12.11	2	12.41	2.02	12.68	2.04
	69.8	7.8	1.13	9.3	1.41	10.8	1.76	11.55	1.94	12.04	2.05	12.3	2.07	12.6	2.08
	73.4	7.8	1.19	9.3	1.51	10.8	1.88	11.55	2.08	11.85	2.14	12.15	2.16	12.41	2.18
	77	7.8	1.27	9.3	1.62	10.8	2.01	11.55	2.23	11.7	2.24	11.96	2.26	12.26	2.28
	80.6	7.8	1.35	9.3	1.73	10.8	2.15	11.36	2.32	11.51	2.33	11.81	2.35	12.08	2.37
	84.2	7.8	1.44	9.3	1.85	10.8	2.3	11.21	2.42	11.36	2.43	11.63	2.45	11.93	2.47
	87.8	7.8	1.54	9.3	1.97	10.8	2.46	11.03	2.51	11.18	2.52	11.48	2.54	11.74	2.57
	91.4	7.8	1.63	9.3	2.1	10.73	2.59	10.87	2.6	11.03	2.62	11.29	2.64	11.59	2.67
95	7.8	1.74	9.3	2.24	10.54	2.68	10.69	2.7	10.84	2.71	11.1	2.74	11.4	2.76	
98.6	7.8	1.85	9.3	2.38	10.39	2.78	10.54	2.79	10.65	2.81	10.95	2.84	11.21	2.86	
102.2	7.8	1.96	9.3	2.54	10.2	2.88	10.35	2.89	10.5	2.9	10.76	2.93	11.06	2.96	
105.8	7.8	1.99	9.3	2.56	10.12	2.9	10.27	2.91	10.42	2.92	10.63	2.95	10.73	2.98	
109.4	7.8	2.01	9.3	2.59	10.04	2.92	10.19	2.93	10.34	2.94	10.53	2.96	10.57	3.04	
100%	23	7.09	0.84	8.44	1.01	9.82	1.21	10.5	1.29	11.18	1.4	12.56	1.6	13.28	1.67
	28.4	7.09	0.85	8.44	1.03	9.82	1.22	10.5	1.32	11.18	1.42	12.56	1.62	13.28	1.68
	32	7.09	0.86	8.44	1.04	9.82	1.23	10.5	1.33	11.18	1.43	12.56	1.64	13.28	1.7
	35.6	7.09	0.88	8.44	1.05	9.82	1.25	10.5	1.35	11.18	1.45	12.56	1.67	13.28	1.72
	39.2	7.09	0.88	8.44	1.06	9.82	1.26	10.5	1.37	11.18	1.47	12.56	1.68	13.28	1.74
	42.8	7.09	0.9	8.44	1.08	9.82	1.28	10.5	1.39	11.18	1.49	12.56	1.71	13.28	1.77
	46.4	7.09	0.91	8.44	1.1	9.82	1.3	10.5	1.41	11.18	1.51	12.56	1.73	13.28	1.8
	50	7.09	0.92	8.44	1.12	9.82	1.33	10.5	1.43	11.18	1.54	12.56	1.76	13.28	1.82
	53.6	7.09	0.94	8.44	1.14	9.82	1.35	10.5	1.46	11.18	1.57	12.56	1.8	13.09	1.84
	57.2	7.09	0.96	8.44	1.16	9.82	1.38	10.5	1.49	11.18	1.6	12.56	1.83	12.94	1.86
	60.8	7.09	0.98	8.44	1.18	9.82	1.41	10.5	1.52	11.18	1.63	12.49	1.85	12.75	1.88
	64.4	7.09	0.99	8.44	1.21	9.82	1.43	10.5	1.55	11.18	1.67	12.34	1.91	12.6	1.93
	68	7.09	1.01	8.44	1.23	9.82	1.47	10.5	1.63	11.18	1.78	12.15	2	12.41	2.02
	69.8	7.09	1.02	8.44	1.24	9.82	1.53	10.5	1.68	11.18	1.85	12.08	2.05	12.34	2.07
	73.4	7.09	1.05	8.44	1.33	9.82	1.64	10.5	1.8	11.18	1.98	11.92	2.15	12.15	2.16
	77	7.09	1.12	8.44	1.42	9.82	1.75	10.5	1.93	11.18	2.12	11.74	2.24	12	2.26
	80.6	7.09	1.19	8.44	1.51	9.82	1.87	10.5	2.07	11.18	2.27	11.55	2.33	11.81	2.35
	84.2	7.09	1.27	8.44	1.61	9.82	2	10.5	2.21	11.14	2.41	11.4	2.43	11.66	2.45
	87.8	7.09	1.35	8.44	1.72	9.82	2.13	10.5	2.35	10.99	2.5	11.21	2.52	11.47	2.55
	91.4	7.09	1.43	8.44	1.83	9.82	2.27	10.5	2.51	10.8	2.6	11.06	2.62	11.33	2.64
95	7.09	1.52	8.44	1.95	9.82	2.42	10.5	2.68	10.61	2.69	10.87	2.72	11.14	2.74	
98.6	7.09	1.62	8.44	2.07	9.82	2.58	10.31	2.77	10.46	2.79	10.72	2.81	10.95	2.84	
102.2	7.09	1.72	8.44	2.2	9.82	2.75	10.16	2.87	10.27	2.88	10.54	2.91	10.8	2.94	
105.8	7.09	1.8	8.44	2.28	9.82	2.85	10	2.89	10.2	2.93	10.35	2.98	10.64	3	
109.4	7.09	1.88	8.44	2.36	9.82	2.9	9.85	2.92	10.12	2.95	10.42	3	10.46	3.03	

**MDV-V105W/DVN1**

**Cooling**

Combination (%) (Capacity index)	Outdoor temperature (°F DB)	Indoor temperature(°FDB/WB)													
		DB:69.4,WB:57.2		DB:73.9,WB:60.8		DB:78.4,WB:64.4		DB:80.6,WB:66.2		DB:82.7,WB:68		DB:87.3,WB:71.6		DB:89.6,WB:75.2	
		TC	PI	TC	PI	TC	PI	TC	PI	TC	PI	TC	PI	TC	PI
		kW	kW	kW	kW	kW	kW	kW	kW	kW	kW	kW	kW	kW	kW
90%	23	6.37	0.74	7.61	0.89	8.85	1.05	9.45	1.15	10.05	1.22	11.29	1.41	12.53	1.61
	28.4	6.37	0.75	7.61	0.9	8.85	1.07	9.45	1.17	10.05	1.24	11.29	1.42	12.53	1.63
	32	6.37	0.76	7.61	0.91	8.85	1.08	9.45	1.18	10.05	1.25	11.29	1.44	12.53	1.64
	35.6	6.37	0.77	7.61	0.93	8.85	1.09	9.45	1.2	10.05	1.27	11.29	1.47	12.53	1.66
	39.2	6.37	0.79	7.61	0.94	8.85	1.11	9.45	1.21	10.05	1.29	11.29	1.49	12.53	1.69
	42.8	6.37	0.8	7.61	0.96	8.85	1.13	9.45	1.24	10.05	1.31	11.29	1.51	12.53	1.72
	46.4	6.37	0.81	7.61	0.98	8.85	1.16	9.45	1.25	10.05	1.33	11.29	1.54	12.53	1.73
	50	6.37	0.83	7.61	1	8.85	1.18	9.45	1.27	10.05	1.37	11.29	1.56	12.53	1.76
	53.6	6.37	0.84	7.61	1.01	8.85	1.2	9.45	1.29	10.05	1.39	11.29	1.59	12.53	1.79
	57.2	6.37	0.86	7.61	1.03	8.85	1.22	9.45	1.32	10.05	1.42	11.29	1.62	12.53	1.82
	60.8	6.37	0.87	7.61	1.05	8.85	1.25	9.45	1.34	10.05	1.44	11.29	1.65	12.49	1.86
	64.4	6.37	0.88	7.61	1.07	8.85	1.27	9.45	1.37	10.05	1.47	11.29	1.68	12.34	1.91
	68	6.37	0.9	7.61	1.1	8.85	1.29	9.45	1.4	10.05	1.53	11.29	1.81	12.15	2
	69.8	6.37	0.91	7.61	1.11	8.85	1.31	9.45	1.44	10.05	1.58	11.29	1.87	12.08	2.05
	73.4	6.37	0.93	7.61	1.15	8.85	1.41	9.45	1.55	10.05	1.7	11.29	2.01	11.89	2.15
	77	6.37	0.98	7.61	1.23	8.85	1.51	9.45	1.66	10.05	1.81	11.29	2.15	11.74	2.24
	80.6	6.37	1.04	7.61	1.31	8.85	1.61	9.45	1.77	10.05	1.94	11.29	2.3	11.55	2.33
	84.2	6.37	1.11	7.61	1.39	8.85	1.72	9.45	1.89	10.05	2.07	11.17	2.41	11.4	2.43
	87.8	6.37	1.18	7.61	1.48	8.85	1.83	9.45	2.02	10.05	2.21	10.99	2.5	11.21	2.52
	91.4	6.37	1.25	7.61	1.58	8.85	1.95	9.45	2.15	10.05	2.36	10.84	2.6	11.06	2.62
95	6.37	1.33	7.61	1.68	8.85	2.08	9.45	2.29	10.05	2.51	10.65	2.69	10.88	2.72	
98.6	6.37	1.41	7.61	1.78	8.85	2.21	9.45	2.44	10.05	2.68	10.46	2.79	10.72	2.81	
102.2	6.37	1.5	7.61	1.9	8.85	2.35	9.45	2.6	10.05	2.85	10.31	2.89	10.54	2.91	
105.8	6.37	1.55	7.61	1.99	8.85	2.44	9.45	2.67	10.05	2.87	10.24	2.96	10.47	2.98	
109.4	6.37	1.62	7.61	2.07	8.85	2.52	9.45	2.73	10.05	2.93	10.19	3	10.38	3.02	
80%	23	5.66	0.66	6.75	0.78	7.84	0.92	8.4	0.98	8.96	1.05	10.05	1.22	11.14	1.39
	28.4	5.66	0.67	6.75	0.79	7.84	0.93	8.4	0.99	8.96	1.06	10.05	1.23	11.14	1.4
	32	5.66	0.68	6.75	0.79	7.84	0.94	8.4	1	8.96	1.08	10.05	1.24	11.14	1.42
	35.6	5.66	0.69	6.75	0.81	7.84	0.95	8.4	1.02	8.96	1.1	10.05	1.27	11.14	1.45
	39.2	5.66	0.7	6.75	0.82	7.84	0.97	8.4	1.05	8.96	1.12	10.05	1.29	11.14	1.47
	42.8	5.66	0.71	6.75	0.84	7.84	0.98	8.4	1.07	8.96	1.14	10.05	1.31	11.14	1.49
	46.4	5.66	0.73	6.75	0.86	7.84	1.01	8.4	1.09	8.96	1.16	10.05	1.33	11.14	1.52
	50	5.66	0.73	6.75	0.88	7.84	1.03	8.4	1.11	8.96	1.19	10.05	1.36	11.14	1.54
	53.6	5.66	0.74	6.75	0.89	7.84	1.05	8.4	1.13	8.96	1.22	10.05	1.39	11.14	1.56
	57.2	5.66	0.76	6.75	0.91	7.84	1.07	8.4	1.15	8.96	1.24	10.05	1.41	11.14	1.59
	60.8	5.66	0.77	6.75	0.92	7.84	1.09	8.4	1.17	8.96	1.26	10.05	1.44	11.14	1.62
	64.4	5.66	0.78	6.75	0.94	7.84	1.11	8.4	1.2	8.96	1.29	10.05	1.47	11.14	1.65
	68	5.66	0.8	6.75	0.96	7.84	1.13	8.4	1.22	8.96	1.31	10.05	1.52	11.14	1.77
	69.8	5.66	0.81	6.75	0.97	7.84	1.14	8.4	1.24	8.96	1.34	10.05	1.58	11.14	1.83
	73.4	5.66	0.82	6.75	0.99	7.84	1.2	8.4	1.31	8.96	1.43	10.05	1.69	11.14	1.97
	77	5.66	0.85	6.75	1.05	7.84	1.28	8.4	1.41	8.96	1.53	10.05	1.81	11.14	2.11
	80.6	5.66	0.9	6.75	1.12	7.84	1.37	8.4	1.5	8.96	1.64	10.05	1.93	11.14	2.25
	84.2	5.66	0.96	6.75	1.19	7.84	1.46	8.4	1.6	8.96	1.75	10.05	2.06	11.14	2.41
	87.8	5.66	1.01	6.75	1.27	7.84	1.55	8.4	1.7	8.96	1.86	10.05	2.2	10.95	2.5
	91.4	5.66	1.08	6.75	1.35	7.84	1.65	8.4	1.81	8.96	1.98	10.05	2.35	10.8	2.6
95	5.66	1.14	6.75	1.43	7.84	1.76	8.4	1.93	8.96	2.11	10.05	2.5	10.61	2.69	
98.6	5.66	1.21	6.75	1.52	7.84	1.87	8.4	2.06	8.96	2.25	10.05	2.67	10.46	2.78	
102.2	5.66	1.29	6.75	1.62	7.84	1.99	8.4	2.19	8.96	2.39	10.05	2.84	10.27	2.88	
105.8	5.66	1.31	6.75	1.64	7.84	2.02	8.4	2.24	8.96	2.44	10.05	2.91	10.21	2.93	
109.4	5.66	1.35	6.75	1.65	7.84	2.04	8.4	2.28	8.96	2.47	10.05	2.95	10.15	2.96	

**MDV-V105W/DVN1**

**Cooling**

Combination (%) (Capacity index)	Outdoor temperature (°F DB)	Indoor temperature(°FDB/WB)													
		DB:69.4,WB:57.2		DB:73.9,WB:60.8		DB:78.4,WB:64.4		DB:80.6,WB:66.2		DB:82.7,WB:68		DB:87.3,WB:71.6		DB:89.6,WB:75.2	
		TC	PI	TC	PI	TC	PI	TC	PI	TC	PI	TC	PI	TC	PI
		kW	kW	kW	kW	kW	kW	kW	kW	kW	kW	kW	kW	kW	kW
70%	23	4.95	0.59	5.92	0.69	6.86	0.78	7.35	0.83	7.84	0.89	8.78	1.02	9.75	1.17
	28.4	4.95	0.59	5.92	0.69	6.86	0.78	7.35	0.85	7.84	0.91	8.78	1.03	9.75	1.19
	32	4.95	0.59	5.92	0.7	6.86	0.8	7.35	0.87	7.84	0.92	8.78	1.06	9.75	1.2
	35.6	4.95	0.6	5.92	0.7	6.86	0.81	7.35	0.88	7.84	0.94	8.78	1.08	9.75	1.22
	39.2	4.95	0.6	5.92	0.72	6.86	0.83	7.35	0.9	7.84	0.96	8.78	1.1	9.75	1.25
	42.8	4.95	0.61	5.92	0.73	6.86	0.85	7.35	0.93	7.84	0.98	8.78	1.11	9.75	1.27
	46.4	4.95	0.63	5.92	0.75	6.86	0.87	7.35	0.94	7.84	1	8.78	1.15	9.75	1.3
	50	4.95	0.64	5.92	0.77	6.86	0.89	7.35	0.96	7.84	1.03	8.78	1.17	9.75	1.31
	53.6	4.95	0.65	5.92	0.78	6.86	0.91	7.35	0.98	7.84	1.05	8.78	1.19	9.75	1.34
	57.2	4.95	0.66	5.92	0.79	6.86	0.92	7.35	0.99	7.84	1.07	8.78	1.21	9.75	1.37
	60.8	4.95	0.68	5.92	0.81	6.86	0.94	7.35	1.01	7.84	1.09	8.78	1.24	9.75	1.39
	64.4	4.95	0.69	5.92	0.82	6.86	0.96	7.35	1.03	7.84	1.11	8.78	1.26	9.75	1.42
	68	4.95	0.7	5.92	0.83	6.86	0.98	7.35	1.05	7.84	1.13	8.78	1.29	9.75	1.46
	69.8	4.95	0.7	5.92	0.84	6.86	0.99	7.35	1.06	7.84	1.14	8.78	1.3	9.75	1.51
	73.4	4.95	0.72	5.92	0.86	6.86	1.01	7.35	1.1	7.84	1.2	8.78	1.4	9.75	1.62
	77	4.95	0.73	5.92	0.89	6.86	1.07	7.35	1.17	7.84	1.27	8.78	1.5	9.75	1.73
	80.6	4.95	0.77	5.92	0.95	6.86	1.15	7.35	1.25	7.84	1.36	8.78	1.6	9.75	1.85
	84.2	4.95	0.82	5.92	1.01	6.86	1.22	7.35	1.33	7.84	1.45	8.78	1.7	9.75	1.98
	87.8	4.95	0.87	5.92	1.07	6.86	1.3	7.35	1.42	7.84	1.54	8.78	1.81	9.75	2.11
	91.4	4.95	0.92	5.92	1.14	6.86	1.38	7.35	1.51	7.84	1.64	8.78	1.93	9.75	2.25
95	4.95	0.98	5.92	1.21	6.86	1.46	7.35	1.6	7.84	1.75	8.78	2.06	9.75	2.39	
98.6	4.95	1.03	5.92	1.28	6.86	1.56	7.35	1.7	7.84	1.86	8.78	2.19	9.75	2.55	
102.2	4.95	1.09	5.92	1.35	6.86	1.65	7.35	1.81	7.84	1.98	8.78	2.33	9.75	2.72	
105.8	4.95	1.14	5.92	1.4	6.86	1.7	7.35	1.87	7.84	2.04	8.78	2.43	9.75	2.84	
109.4	4.95	1.23	5.92	1.5	6.86	1.77	7.35	1.97	7.84	2.1	8.78	2.51	9.75	2.92	
60%	23	4.24	0.5	5.06	0.58	5.89	0.67	6.3	0.72	6.71	0.78	7.54	0.87	8.36	1
	28.4	4.24	0.5	5.06	0.59	5.89	0.69	6.3	0.73	6.71	0.78	7.54	0.89	8.36	1.01
	32	4.24	0.51	5.06	0.6	5.89	0.7	6.3	0.74	6.71	0.8	7.54	0.9	8.36	1.02
	35.6	4.24	0.52	5.06	0.61	5.89	0.71	6.3	0.75	6.71	0.81	7.54	0.92	8.36	1.03
	39.2	4.24	0.53	5.06	0.62	5.89	0.72	6.3	0.76	6.71	0.82	7.54	0.93	8.36	1.05
	42.8	4.24	0.54	5.06	0.63	5.89	0.74	6.3	0.78	6.71	0.84	7.54	0.95	8.36	1.07
	46.4	4.24	0.55	5.06	0.64	5.89	0.75	6.3	0.79	6.71	0.85	7.54	0.97	8.36	1.09
	50	4.24	0.56	5.06	0.66	5.89	0.76	6.3	0.82	6.71	0.87	7.54	0.99	8.36	1.11
	53.6	4.24	0.57	5.06	0.67	5.89	0.78	6.3	0.83	6.71	0.88	7.54	1	8.36	1.12
	57.2	4.24	0.58	5.06	0.68	5.89	0.79	6.3	0.85	6.71	0.9	7.54	1.02	8.36	1.14
	60.8	4.24	0.59	5.06	0.69	5.89	0.8	6.3	0.86	6.71	0.92	7.54	1.04	8.36	1.17
	64.4	4.24	0.6	5.06	0.7	5.89	0.82	6.3	0.87	6.71	0.94	7.54	1.06	8.36	1.19
	68	4.24	0.6	5.06	0.72	5.89	0.83	6.3	0.89	6.71	0.95	7.54	1.08	8.36	1.21
	69.8	4.24	0.61	5.06	0.72	5.89	0.84	6.3	0.9	6.71	0.96	7.54	1.09	8.36	1.22
	73.4	4.24	0.62	5.06	0.73	5.89	0.85	6.3	0.92	6.71	0.98	7.54	1.13	8.36	1.3
	77	4.24	0.63	5.06	0.74	5.89	0.88	6.3	0.96	6.71	1.04	7.54	1.21	8.36	1.39
	80.6	4.24	0.65	5.06	0.79	5.89	0.94	6.3	1.03	6.71	1.11	7.54	1.29	8.36	1.48
	84.2	4.24	0.69	5.06	0.84	5.89	1	6.3	1.09	6.71	1.18	7.54	1.38	8.36	1.59
	87.8	4.24	0.73	5.06	0.89	5.89	1.07	6.3	1.16	6.71	1.26	7.54	1.46	8.36	1.69
	91.4	4.24	0.77	5.06	0.94	5.89	1.13	6.3	1.23	6.71	1.34	7.54	1.56	8.36	1.8
95	4.24	0.82	5.06	1	5.89	1.2	6.3	1.31	6.71	1.42	7.54	1.66	8.36	1.91	
98.6	4.24	0.87	5.06	1.06	5.89	1.27	6.3	1.39	6.71	1.51	7.54	1.76	8.36	2.04	
102.2	4.24	0.91	5.06	1.12	5.89	1.35	6.3	1.47	6.71	1.6	7.54	1.87	8.36	2.17	
105.8	4.24	0.94	5.06	1.17	5.89	1.4	6.3	1.53	6.71	1.66	7.54	1.96	8.36	2.26	
109.4	4.24	0.97	5.06	1.22	5.89	1.45	6.3	1.57	6.71	1.72	7.54	2.04	8.36	2.36	



**MDV-V105W/DVN1**

**Cooling**

Combination (%) (Capacity index)	Outdoor temperature (°F DB)	Indoor temperature(°FDB/WB)													
		DB:69.4, WB:57.2		DB:73.9, WB:60.8		DB:78.4, WB:64.4		DB:80.6, WB:66.2		DB:82.7, WB:68		DB:87.3, WB:71.6		DB:89.6, WB:75.2	
		TC	PI	TC	PI	TC	PI	TC	PI	TC	PI	TC	PI	TC	PI
		kW	kW	kW	kW	kW	kW	kW	kW	kW	kW	kW	kW	kW	kW
50%	23	3.54	0.43	4.24	0.5	4.91	0.58	5.25	0.6	5.59	0.64	6.26	0.72	6.98	0.78
	28.4	3.54	0.44	4.24	0.51	4.91	0.58	5.25	0.61	5.59	0.65	6.26	0.73	6.98	0.79
	32	3.54	0.44	4.24	0.52	4.91	0.59	5.25	0.62	5.59	0.66	6.26	0.75	6.98	0.8
	35.6	3.54	0.45	4.24	0.53	4.91	0.6	5.25	0.63	5.59	0.67	6.26	0.75	6.98	0.82
	39.2	3.54	0.45	4.24	0.54	4.91	0.61	5.25	0.64	5.59	0.68	6.26	0.77	6.98	0.84
	42.8	3.54	0.46	4.24	0.54	4.91	0.62	5.25	0.65	5.59	0.69	6.26	0.78	6.98	0.87
	46.4	3.54	0.47	4.24	0.55	4.91	0.63	5.25	0.67	5.59	0.7	6.26	0.79	6.98	0.89
	50	3.54	0.48	4.24	0.56	4.91	0.64	5.25	0.68	5.59	0.72	6.26	0.81	6.98	0.91
	53.6	3.54	0.49	4.24	0.57	4.91	0.65	5.25	0.69	5.59	0.74	6.26	0.83	6.98	0.92
	57.2	3.54	0.49	4.24	0.57	4.91	0.66	5.25	0.7	5.59	0.75	6.26	0.84	6.98	0.94
	60.8	3.54	0.5	4.24	0.58	4.91	0.67	5.25	0.72	5.59	0.76	6.26	0.86	6.98	0.95
	64.4	3.54	0.51	4.24	0.59	4.91	0.68	5.25	0.73	5.59	0.77	6.26	0.87	6.98	0.97
	68	3.54	0.52	4.24	0.6	4.91	0.69	5.25	0.74	5.59	0.79	6.26	0.88	6.98	0.99
	69.8	3.54	0.52	4.24	0.61	4.91	0.7	5.25	0.74	5.59	0.79	6.26	0.9	6.98	1
	73.4	3.54	0.53	4.24	0.61	4.91	0.71	5.25	0.76	5.59	0.81	6.26	0.91	6.98	1.02
	77	3.54	0.53	4.24	0.62	4.91	0.72	5.25	0.77	5.59	0.83	6.26	0.96	6.98	1.09
	80.6	3.54	0.55	4.24	0.65	4.91	0.76	5.25	0.82	5.59	0.88	6.26	1.02	6.98	1.16
	84.2	3.54	0.57	4.24	0.69	4.91	0.81	5.25	0.87	5.59	0.94	6.26	1.08	6.98	1.24
	87.8	3.54	0.61	4.24	0.73	4.91	0.86	5.25	0.93	5.59	1	6.26	1.15	6.98	1.32
	91.4	3.54	0.64	4.24	0.77	4.91	0.91	5.25	0.98	5.59	1.06	6.26	1.22	6.98	1.4
95	3.54	0.68	4.24	0.81	4.91	0.96	5.25	1.04	5.59	1.12	6.26	1.3	6.98	1.49	
98.6	3.54	0.72	4.24	0.86	4.91	1.02	5.25	1.1	5.59	1.19	6.26	1.38	6.98	1.58	
102.2	3.54	0.75	4.24	0.91	4.91	1.08	5.25	1.17	5.59	1.26	6.26	1.46	6.98	1.68	
105.8	3.54	0.79	4.24	0.95	4.91	1.12	5.25	1.22	5.59	1.32	6.26	1.54	6.98	1.76	
109.4	3.54	0.84	4.24	1.01	4.91	1.15	5.25	1.28	5.59	1.35	6.26	1.62	6.98	1.84	

**Note:**

1. is tested under our standard condition.
2. Avoid to run the unit when the temperature is above 109.4°F (43°C).
3. The above table shows the average value of conditions may operate.
4. It is recommended to connect less than 130%.

**MDV-V105W/DVN1**  
**Heating**

Combination (%) (Capacity index)	Outdoor Air temperature(°F)		Indoor temperature(°F WB)											
			60.8		64.4		68		69.8		71.6		75.2	
	°F DB	°F WB	TC	PI	TC	PI	TC	PI	TC	PI	TC	PI	TC	PI
			kW	kW	kW	kW	kW	kW	kW	kW	kW	kW	kW	kW
130%	7.34	5	8.18	2.29	8.14	2.43	8.1	2.56	8.1	2.62	8.07	2.69	8.07	2.82
	10.76	8.6	8.51	2.4	8.51	2.52	8.47	2.65	8.43	2.71	8.43	2.78	8.4	2.9
	14.36	12.2	8.91	2.5	8.87	2.62	8.83	2.74	8.83	2.8	8.83	2.86	8.8	2.98
	14.9	14	9.13	2.55	9.09	2.67	9.05	2.79	9.05	2.85	9.02	2.9	9.02	3.02
	16.7	15.62	9.31	2.6	9.27	2.71	9.27	2.83	9.24	2.88	9.24	2.94	9.2	3.06
	19.4	18.32	9.64	2.67	9.64	2.79	9.6	2.9	9.6	2.95	9.56	3.01	9.53	3.12
	23	21.92	10.15	2.78	10.11	2.88	10.08	2.99	10.08	3.04	10.04	3.09	10.04	3.19
	26.6	25.34	10.62	2.87	10.59	2.97	10.59	3.07	10.55	3.12	10.55	3.17	10.51	3.27
	32	30.74	11.46	3.01	11.46	3.1	11.43	3.19	11.43	3.22	11.39	3.28	11.39	3.37
	37.4	35.96	12.38	3.13	12.34	3.22	12.3	3.3	12.3	3.34	12.3	3.39	12.27	3.47
	41	39.38	13	3.21	12.96	3.29	12.96	3.37	12.92	3.41	12.92	3.45	12.89	3.53
	44.6	42.8	13.65	3.28	13.62	3.36	13.62	3.44	13.58	3.48	13.58	3.51	13.03	3.37
	48.2	46.22	14.35	3.35	14.31	3.43	14.31	3.5	14.27	3.54	13.98	3.46	13.03	3.17
	51.8	49.64	15.08	3.42	15.04	3.49	14.97	3.53	14.46	3.39	13.98	3.25	13.03	2.99
	55.4	53.24	15.88	3.48	15.84	3.55	14.97	3.31	14.46	3.18	13.98	3.05	13.03	2.8
59	56.66	16.65	3.54	15.92	3.36	14.97	3.12	14.46	3	13.98	2.88	13.03	2.64	
120%	7.34	5	8.14	2.47	8.11	2.59	8.07	2.71	8.07	2.78	8.07	2.84	8.03	2.96
	10.76	8.6	8.47	2.56	8.47	2.68	8.43	2.8	8.43	2.86	8.4	2.91	8.4	3.03
	14.36	12.2	8.87	2.66	8.83	2.77	8.83	2.88	8.8	2.94	8.8	2.99	8.76	3.11
	14.9	14	9.09	2.71	9.05	2.82	9.02	2.93	9.02	2.98	9.02	3.04	8.98	3.14
	16.7	15.62	9.27	2.75	9.24	2.86	9.24	2.96	9.2	3.02	9.2	3.07	9.16	3.18
	19.4	18.32	9.6	2.82	9.6	2.93	9.57	3.03	9.57	3.08	9.53	3.13	9.53	3.23
	23	21.92	10.11	2.91	10.08	3.01	10.04	3.11	10.04	3.16	10.04	3.21	10	3.3
	26.6	25.34	10.59	3	10.59	3.1	10.55	3.19	10.55	3.23	10.51	3.28	10.51	3.37
	32	30.74	11.43	3.13	11.43	3.22	11.39	3.3	11.39	3.34	11.35	3.39	11.35	3.47
	37.4	35.96	12.34	3.25	12.3	3.33	12.3	3.4	12.27	3.45	12.27	3.48	12.01	3.47
	41	39.38	12.96	3.32	12.92	3.39	12.92	3.47	12.89	3.51	12.89	3.54	12.01	3.25
	44.6	42.8	13.62	3.39	13.62	3.46	13.58	3.53	13.36	3.48	12.92	3.34	12.01	3.06
	48.2	46.22	14.31	3.45	14.28	3.52	13.8	3.4	13.36	3.27	12.92	3.14	12.01	2.88
	51.8	49.64	15.04	3.51	14.68	3.45	13.8	3.2	13.36	3.08	12.92	2.95	12.01	2.72
	55.4	53.24	15.59	3.48	14.68	3.24	13.8	3	13.36	2.89	12.92	2.78	12.01	2.55
59	56.66	15.59	3.28	14.68	3.05	13.8	2.83	13.36	2.72	12.92	2.62	12.01	2.41	
110%	7.34	5	8.11	2.65	8.07	2.76	8.03	2.87	8.03	2.93	8.03	2.98	8	3.09
	10.76	8.6	8.43	2.74	8.43	2.84	8.4	2.95	8.4	3	8.36	3.05	8.36	3.16
	14.36	12.2	8.83	2.82	8.8	2.93	8.8	3.03	8.76	3.08	8.76	3.13	8.76	3.23
	14.9	14	9.05	2.87	9.02	2.97	8.98	3.07	8.98	3.12	8.98	3.17	8.95	3.27
	16.7	15.62	9.24	2.91	9.2	3.01	9.2	3.1	9.16	3.15	9.16	3.2	9.16	2.92
	19.4	18.32	9.56	2.98	9.56	3.07	9.53	3.16	9.53	3.21	9.53	3.25	9.49	3.35
	23	21.92	10.08	3.06	10.04	3.15	10	3.24	10	3.28	10	3.33	9.97	3.42
	26.6	25.34	10.55	3.14	10.55	3.22	10.51	3.31	10.51	3.35	10.48	3.39	10.48	3.48
	32	30.74	11.39	3.25	11.39	3.33	11.35	3.41	11.35	3.45	11.35	3.49	11.03	3.42
	37.4	35.96	12.3	3.36	12.27	3.44	12.27	3.51	12.23	3.54	11.83	3.4	11.03	3.11
	41	39.38	12.92	3.43	12.92	3.5	12.67	3.46	12.23	3.33	11.83	3.19	11.03	2.93
	44.6	42.8	13.58	3.49	13.47	3.51	12.67	3.25	12.23	3.13	11.83	3	11.03	2.76
	48.2	46.22	14.27	3.55	13.47	3.3	12.67	3.06	12.23	2.94	11.83	2.82	11.03	2.6
	51.8	49.64	14.27	3.34	13.47	3.11	12.67	2.88	12.23	2.77	11.83	2.66	11.03	2.45
	55.4	53.24	14.27	3.13	13.47	2.92	12.67	2.71	12.23	2.61	11.83	2.5	11.03	2.31
59	56.66	14.27	2.78	13.47	2.75	12.67	2.56	12.23	2.46	11.83	2.37	11.03	2.18	

**MDV-V105W/DVN1**

**Heating**

Combination (%) (Capacity index)	Outdoor Air temperature(°F)		Indoor temperature(°F WB)											
			60.8		64.4		68		69.8		71.6		75.2	
	°F DB	°F WB	TC	PI	TC	PI	TC	PI	TC	PI	TC	PI	TC	PI
			kW	kW	kW	kW	kW	kW	kW	kW	kW	kW	kW	kW
100%	7.34	5	8.07	2.82	8.03	2.93	7.99	3.03	7.99	3.08	7.99	3.13	7.96	3.23
	10.76	8.6	8.4	2.91	8.4	3	8.36	3.1	8.36	3.15	8.36	3.2	8.32	3.3
	14.36	12.2	8.8	2.99	8.76	3.08	8.76	3.17	8.76	3.22	8.73	3.27	8.73	3.36
	14.9	14	9.02	3.03	8.98	3.12	8.98	3.21	8.94	3.25	8.94	3.3	8.91	3.39
	16.7	15.62	9.2	3.06	9.16	3.15	9.16	3.24	9.16	3.28	9.13	3.33	9.13	3.42
	19.4	18.32	9.53	3.12	9.53	3.21	9.49	3.29	9.49	3.34	9.49	3.38	9.46	3.46
	23	21.92	10.04	3.2	10	3.28	10	3.36	9.97	3.4	9.97	3.44	9.93	3.53
	26.6	25.34	10.51	3.27	10.51	2.97	10.48	3.43	10.48	3.46	10.48	3.5	10.04	3.36
	32	30.74	11.35	3.38	11.35	3.45	11.32	3.52	11.14	3.46	10.77	3.32	10.04	3.05
	37.4	35.96	12.27	3.48	12.23	3.54	11.5	3.28	11.14	3.15	10.77	3.02	10.04	2.78
	41	39.38	12.89	3.54	12.23	3.33	11.5	3.08	11.14	2.96	10.77	2.85	10.04	2.62
	44.6	42.8	12.96	3.36	12.23	3.13	11.5	2.9	11.14	2.79	10.77	2.68	10.04	2.47
	48.2	46.22	12.96	3.16	12.23	2.94	11.5	2.73	11.14	2.59	10.77	2.53	10.04	2.33
	51.8	49.64	12.96	2.97	12.23	2.77	11.5	2.58	11.14	2.48	10.77	2.38	10.04	2.2
	55.4	53.24	12.96	2.79	12.23	2.61	11.5	2.43	11.14	2.34	10.77	2.25	10.04	2.08
	59	56.66	12.96	2.63	12.23	2.46	11.5	2.29	11.14	2.21	10.77	2.12	10.04	1.97
90%	7.34	5	8.02	3.01	7.98	3.1	7.98	3.19	7.94	3.23	7.94	3.28	7.94	3.37
	10.76	8.6	8.35	3.08	8.35	3.16	8.31	3.25	8.31	3.3	8.31	3.34	8.27	3.42
	14.36	12.2	8.75	3.15	8.75	3.23	8.71	3.31	8.71	3.36	8.71	3.4	8.67	3.48
	14.9	14	8.97	3.19	8.93	3.27	8.93	3.35	8.89	3.39	8.89	3.43	8.89	3.51
	16.7	15.62	9.15	3.22	9.15	3.3	9.11	3.38	9.11	3.42	9.11	3.46	9	3.49
	19.4	18.32	9.48	3.27	9.48	3.35	9.44	3.43	9.44	3.46	9.44	3.5	9	3.33
	23	21.92	9.99	3.34	9.95	3.42	9.95	3.49	9.91	3.53	9.66	3.42	9	3.13
	26.6	25.34	10.46	3.41	10.46	3.48	10.35	3.49	9.99	3.35	9.66	3.22	9	2.95
	32	30.74	11.33	3.51	11.01	3.42	10.35	3.17	9.99	3.04	9.66	2.92	9	2.69
	37.4	35.96	11.66	3.34	11.01	3.11	10.35	2.88	9.99	2.78	9.66	2.67	9	2.46
	41	39.38	11.66	3.14	11.01	2.93	10.35	2.72	9.99	2.61	9.66	2.52	9	2.32
	44.6	42.8	11.66	2.95	11.01	2.76	10.35	2.56	9.99	2.47	9.66	2.37	9	2.19
	48.2	46.22	11.66	2.78	11.01	2.59	10.35	2.41	9.99	2.33	9.66	2.24	9	2.07
	51.8	49.64	11.66	2.62	11.01	2.45	10.35	2.28	9.99	2.2	9.66	2.12	9	1.96
	55.4	53.24	11.66	2.47	11.01	2.31	10.35	2.15	9.99	2.08	9.66	2	9	1.85
	59	56.66	11.66	2.33	11.01	2.18	10.35	2.04	9.99	1.97	9.66	1.89	9	1.76
80%	7.34	5	7.99	3.18	7.96	3.26	7.96	3.34	7.96	3.38	7.92	3.42	7.92	3.51
	10.76	8.6	8.32	3.25	8.32	3.33	8.29	3.4	8.29	3.44	8.29	3.48	8.03	3.39
	14.36	12.2	8.73	3.31	8.73	3.39	8.69	3.46	8.69	3.49	8.62	3.49	8.03	3.2
	14.9	14	8.94	3.34	8.91	3.42	8.91	3.49	8.91	3.53	8.62	3.39	8.03	3.1
	16.7	15.62	9.13	3.37	8.48	3.45	9.09	3.51	8.91	3.43	8.62	3.3	8.03	3.02
	19.4	18.32	9.46	3.42	9.46	3.49	9.2	3.42	8.91	3.28	8.62	3.15	8.03	2.89
	23	21.92	9.97	3.48	9.78	3.46	9.2	3.21	8.91	3.08	8.62	2.96	8.03	2.72
	26.6	25.34	10.37	3.5	9.78	3.26	9.2	3.02	8.91	2.91	8.62	2.79	8.03	2.57
	32	30.74	10.37	3.18	9.78	2.96	9.2	2.75	8.91	2.65	8.62	2.54	8.03	2.34
	37.4	35.96	10.37	2.9	9.78	2.7	9.2	2.51	8.91	2.42	8.62	2.33	8.03	2.15
	41	39.38	10.37	2.73	9.78	2.55	9.2	2.37	8.91	2.28	8.62	2.2	8.03	2.03
	44.6	42.8	10.37	2.57	9.78	2.4	9.2	2.24	8.91	2.16	8.62	2.08	8.03	1.92
	48.2	46.22	10.37	2.43	9.78	2.27	9.2	2.11	8.91	2.04	8.62	1.97	8.03	1.82
	51.8	49.64	10.37	2.29	9.78	2.14	9.2	2	8.91	1.93	8.62	1.86	8.03	1.72
	55.4	53.24	10.37	2.16	9.78	2.02	9.2	1.89	8.91	1.82	8.62	1.76	8.03	1.63
	59	56.66	10.37	2.04	9.78	1.92	9.2	1.79	8.91	1.73	8.62	1.67	8.03	1.55

**MDV-V105W/DVN1**

**Heating**

Combination (%) (Capacity index)	Outdoor Air temperature(°F)		Indoor temperature(°F WB)											
			60.8		64.4		68		69.8		71.6		75.2	
	°F DB	°F WB	TC	PI	TC	PI	TC	PI	TC	PI	TC	PI	TC	PI
70%	7.34	5	7.94	3.36	7.9	3.43	7.9	3.5	7.76	3.45	7.5	3.31	6.99	3.04
	10.76	8.6	8.27	3.42	8.27	3.48	8.05	3.4	7.76	3.27	7.5	3.14	6.99	2.88
	14.36	12.2	8.67	3.47	8.56	3.47	8.05	3.21	7.76	3.09	7.5	2.96	6.99	2.72
	14.9	14	8.89	3.5	8.56	3.37	8.05	3.12	7.76	3	7.5	2.88	6.99	2.65
	16.7	15.62	9.07	3.52	8.56	3.28	8.05	3.04	7.76	2.92	7.5	2.81	6.99	2.58
	19.4	18.32	9.07	3.36	8.56	3.13	8.05	2.9	7.76	2.79	7.5	2.69	6.99	2.47
	23	21.92	9.07	3.16	8.56	2.94	8.05	2.73	7.76	2.63	7.5	3.11	6.99	2.33
	26.6	25.34	9.07	2.98	8.56	2.78	8.05	2.58	7.76	2.48	7.5	2.39	6.99	2.2
	32	30.74	9.07	2.71	8.56	2.53	8.05	2.35	7.76	2.27	7.5	2.18	6.99	2.02
	37.4	35.96	9.07	2.47	8.56	2.32	8.05	2.16	7.76	2.08	7.5	2	6.99	1.85
	41	39.38	9.07	2.33	8.56	2.18	8.05	2.04	7.76	1.97	7.5	1.89	6.99	1.76
	44.6	42.8	9.07	2.21	8.56	2.07	8.05	1.93	7.76	1.86	7.5	1.8	6.99	1.66
	48.2	46.22	9.07	2.09	8.56	1.95	8.05	1.83	7.76	1.76	7.5	1.7	6.99	1.58
	51.8	49.64	9.07	1.97	8.56	1.85	8.05	1.73	7.76	1.67	7.5	1.62	6.99	1.5
	55.4	53.24	9.07	1.86	8.56	1.75	8.05	1.64	7.76	1.59	7.5	1.53	6.99	1.42
59	56.66	9.07	1.77	8.56	1.66	8.05	1.56	7.76	1.51	7.5	1.45	6.99	1.36	
60%	7.34	5	7.78	3.45	7.34	3.21	6.9	2.98	6.68	2.86	6.46	2.75	6.02	2.53
	10.76	8.6	7.78	3.27	7.34	3.04	6.9	2.82	6.68	2.72	6.46	2.61	6.02	2.41
	14.36	12.2	7.78	3.08	7.34	2.87	6.9	2.67	6.68	2.57	6.46	2.47	6.02	2.28
	14.9	14	7.78	3	7.34	2.79	6.9	2.59	6.68	2.5	6.46	2.4	6.02	2.21
	16.7	15.62	7.78	2.92	7.34	2.72	6.9	2.53	6.68	2.44	6.46	2.34	6.02	2.16
	19.4	18.32	7.78	2.79	7.34	2.61	6.9	2.42	6.68	2.33	6.46	2.24	6.02	2.08
	23	21.92	7.78	2.63	7.34	2.46	6.9	2.29	6.68	2.2	6.46	2.12	6.02	1.96
	26.6	25.34	7.78	2.48	7.34	2.32	6.9	2.16	6.68	2.09	6.46	2.01	6.02	1.86
	32	30.74	7.78	2.27	7.34	2.12	6.9	1.98	6.68	1.91	6.46	1.84	6.02	1.71
	37.4	35.96	7.78	2.08	7.34	1.95	6.9	1.82	6.68	1.76	6.46	1.7	6.02	1.57
	41	39.38	7.78	1.97	7.34	1.85	6.9	1.72	6.68	1.67	6.46	1.61	6.02	1.5
	44.6	42.8	7.78	1.86	7.34	1.75	6.9	1.63	6.68	1.58	6.46	1.53	6.02	1.42
	48.2	46.22	7.78	1.76	7.34	1.66	6.9	1.55	6.68	1.5	6.46	1.45	6.02	1.35
	51.8	49.64	7.78	1.67	7.34	1.57	6.9	1.48	6.68	1.43	6.46	1.38	6.02	1.29
	55.4	53.24	7.78	1.58	7.34	1.49	6.9	1.4	6.68	1.36	6.46	1.31	6.02	1.22
59	56.66	7.78	1.51	7.34	1.42	6.9	1.33	6.68	1.29	6.46	1.25	6.02	1.17	
50%	7.34	5	6.48	2.76	6.11	2.58	5.75	2.4	5.53	2.31	5.35	2.23	4.99	2.06
	10.76	8.6	6.48	2.62	6.11	2.45	5.75	2.28	5.53	2.2	5.35	2.12	4.99	1.96
	14.36	12.2	6.48	2.49	6.11	2.32	5.75	2.17	5.53	2.09	5.35	2.01	4.99	1.86
	14.9	14	6.48	2.42	6.11	2.26	5.75	2.11	5.53	2.03	5.35	1.96	4.99	1.81
	16.7	15.62	6.48	2.36	6.11	2.21	5.75	2.06	5.53	1.98	5.35	1.91	4.99	1.77
	19.4	18.32	6.48	2.26	6.11	2.12	5.75	1.97	5.53	1.91	5.35	1.84	4.99	1.7
	23	21.92	6.48	2.13	6.11	2	5.75	1.87	5.53	1.8	5.35	1.74	4.99	1.61
	26.6	25.34	6.48	2.02	6.11	1.89	5.75	1.77	5.53	1.71	5.35	1.65	4.99	1.53
	32	30.74	6.48	1.85	6.11	1.74	5.75	1.63	5.53	1.57	5.35	1.52	4.99	1.42
	37.4	35.96	6.48	1.71	6.11	1.6	5.75	1.5	5.53	1.45	5.35	1.4	4.99	1.31
	41	39.38	6.48	1.62	6.11	1.52	5.75	1.43	5.53	1.38	5.35	1.34	4.99	1.25
	44.6	42.8	6.48	1.54	6.11	1.45	5.75	1.36	5.53	1.31	5.35	1.27	4.99	1.19
	48.2	46.22	6.48	1.46	6.11	1.37	5.75	1.29	5.53	1.25	5.35	1.21	4.99	1.13
	51.8	49.64	6.48	1.39	6.11	1.31	5.75	1.23	5.53	1.19	5.35	1.16	4.99	1.08
	55.4	53.24	6.48	1.32	6.11	1.24	5.75	1.17	5.53	1.14	5.35	1.1	4.99	1.03
59	56.66	6.48	1.25	6.11	1.19	5.75	1.12	5.53	1.08	5.35	1.05	4.99	0.99	

**Note:**

1. [ ] is tested under our standard condition.
2. Avoid to run the unit when the temperature is below 5°F (-15°C).
3. The above table shows the average value of conditions may operate.
4. It is recommended to connect less than 130%.

**MDV-V120W/DVN1**

**Cooling**

Combination (%) (Capacity index)	Outdoor temperature (°F DB)	Indoor temperature(°FDB/WB)													
		DB:69.4,WB:57.2		DB:73.9,WB:60.8		DB:78.4,WB:64.4		DB:80.6,WB:66.2		DB:82.7,WB:68		DB:87.3,WB:71.6		DB:89.6,WB:75.2	
		TC	PI	TC	PI	TC	PI	TC	PI	TC	PI	TC	PI	TC	PI
		kW	kW	kW	kW	kW	kW	kW	kW	kW	kW	kW	kW	kW	kW
130%	23	10.54	1.33	12.56	1.62	14.57	1.74	15.13	1.81	15.86	1.86	16.24	2.02	16.65	2.04
	28.4	10.54	1.33	12.56	1.65	14.57	1.74	15.13	1.82	15.86	1.86	16.24	2.05	16.65	2.06
	32	10.54	1.35	12.56	1.68	14.57	1.8	15.13	1.92	15.86	1.97	16.24	2.07	16.65	2.08
	35.6	10.54	1.38	12.56	1.69	14.57	1.86	15.13	2.03	15.86	1.99	16.24	2.09	16.65	2.11
	39.2	10.54	1.41	12.56	1.72	14.57	1.93	15.13	2.04	15.86	2.02	16.24	2.09	16.65	2.15
	42.8	10.54	1.43	12.56	1.75	14.57	2	15.13	2.05	15.68	2.08	16.04	2.09	16.47	2.17
	46.4	10.54	1.47	12.56	1.79	14.57	2.1	15.13	2.15	15.48	2.15	15.87	3.9	16.26	2.19
	50	10.54	1.5	12.56	1.83	14.57	2.18	15.13	2.23	15.3	4.04	15.69	4.06	16.07	2.25
	53.6	10.54	1.52	12.56	1.87	14.57	2.22	14.91	4.03	15.13	4.06	15.47	4.07	15.86	2.27
	57.2	10.54	1.56	12.56	1.9	14.53	4.05	14.74	4.06	14.91	4.08	15.3	4.09	15.69	2.32
	60.8	10.54	1.58	12.56	1.94	14.36	4.06	14.53	4.08	14.7	4.1	15.09	4.12	15.47	2.36
	64.4	10.54	1.61	12.56	1.98	14.14	2.32	14.31	2.33	14.53	2.35	14.91	2.37	15.3	2.39
	68	10.54	1.65	12.56	2.11	13.93	2.44	14.14	2.45	14.31	2.46	14.7	2.48	15.09	2.51
	69.8	10.54	1.69	12.56	2.18	13.84	2.49	14.06	2.51	14.23	2.52	14.61	2.55	15	2.57
	73.4	10.54	1.81	12.56	2.34	13.67	2.61	13.84	2.62	14.01	2.63	14.4	2.66	14.78	2.69
	77	10.54	1.94	12.56	2.51	13.46	2.72	13.63	2.73	13.84	2.75	14.23	2.78	14.61	2.8
	80.6	10.54	2.07	12.56	2.68	13.29	2.83	13.46	2.85	13.63	2.86	14.01	2.9	14.4	2.93
	84.2	10.54	2.21	12.56	2.86	13.07	2.95	13.24	2.97	13.46	2.98	13.84	3.01	14.23	3.04
	87.8	10.54	2.36	12.51	3.03	12.86	3.07	13.07	3.08	13.24	3.1	13.63	3.13	14.01	3.17
	91.4	10.54	2.51	12.3	3.15	12.69	3.18	12.86	3.2	13.07	3.22	13.46	3.25	13.8	3.29
95	10.54	2.68	12.09	3.26	12.47	3.3	12.69	3.32	12.86	3.33	13.24	3.37	13.63	3.41	
98.6	10.54	2.85	11.91	3.38	12.3	3.42	12.47	3.43	12.69	3.46	13.03	3.5	13.41	3.54	
102.2	10.54	3.03	11.7	3.41	12.09	3.53	12.3	3.55	12.47	3.57	12.86	3.61	13.24	3.66	
105.8	10.54	3.19	11.58	3.45	11.96	3.56	12.17	3.59	12.34	3.61	12.73	3.62	12.73	3.69	
109.4	10.54	3.27	11.49	3.46	11.89	3.57	12.11	3.6	12.22	3.61	12.5	3.63	12.58	3.7	
120%	23	9.73	1.28	11.57	1.55	13.46	1.84	14.4	2	15.09	2.09	15.43	2.16	15.77	2.21
	28.4	9.73	1.3	11.57	1.57	13.46	1.86	14.4	2.02	15.09	2.11	15.43	2.17	15.77	2.22
	32	9.73	1.31	11.57	1.58	13.46	1.88	14.4	2.02	15.09	2.13	15.43	2.19	15.77	2.23
	35.6	9.73	1.31	11.57	1.6	13.46	1.89	14.4	2.04	15.09	2.14	15.43	2.2	15.77	2.23
	39.2	9.73	1.32	11.57	1.62	13.46	1.92	14.4	2.06	15.09	2.17	15.43	2.21	15.77	2.24
	42.8	9.73	1.34	11.57	1.63	13.46	1.94	14.4	2.08	15.09	2.19	15.43	2.23	15.77	2.24
	46.4	9.73	1.35	11.57	1.65	13.46	1.97	14.4	2.11	15.09	2.22	15.43	2.23	15.77	2.25
	50	9.73	1.37	11.57	1.67	13.46	1.98	14.4	2.15	15.09	2.22	15.43	2.24	15.77	2.26
	53.6	9.73	1.39	11.57	1.7	13.46	2.02	14.4	2.19	14.87	2.23	15.21	2.23	15.56	2.28
	57.2	9.73	1.42	11.57	1.73	13.46	2.06	14.4	2.23	14.66	2.24	15.04	2.26	15.39	2.31
	60.8	9.73	1.45	11.57	1.77	13.46	2.1	14.31	4.1	14.49	2.27	14.83	2.3	15.17	2.34
	64.4	9.73	1.47	11.57	1.8	13.46	2.17	14.1	2.32	14.27	2.33	14.61	2.35	15	2.37
	68	9.73	1.5	11.57	1.87	13.46	2.34	13.93	2.44	14.1	2.44	14.44	2.47	14.79	2.49
	69.8	9.73	1.52	11.57	1.94	13.46	2.42	13.8	2.49	13.97	2.5	14.36	2.52	14.7	2.55
	73.4	9.73	1.62	11.57	2.08	13.46	2.59	13.63	2.6	13.8	2.62	14.14	2.64	14.49	2.66
	77	9.73	1.73	11.57	2.23	13.24	2.71	13.41	2.72	13.59	2.73	13.97	2.75	14.31	2.78
	80.6	9.73	1.85	11.57	2.38	13.07	2.82	13.24	2.83	13.41	2.85	13.76	2.87	14.1	2.9
	84.2	9.73	1.97	11.57	2.54	12.86	2.93	13.03	2.95	13.2	2.96	13.54	2.99	13.93	3.02
	87.8	9.73	2.1	11.57	2.71	12.64	3.05	12.86	3.06	13.03	3.08	13.37	3.11	13.71	3.14
	91.4	9.73	2.24	11.57	2.89	12.47	3.16	12.64	3.18	12.81	3.19	13.16	3.23	13.5	3.26
95	9.73	2.38	11.57	3.08	12.26	3.28	12.43	3.29	12.64	3.31	12.99	3.35	13.33	3.38	
98.6	9.73	2.54	11.57	3.28	12.09	3.39	12.26	3.41	12.43	3.43	12.77	3.46	13.11	3.5	
102.2	9.73	2.7	11.53	3.47	11.87	3.51	12.04	3.53	12.21	3.55	12.6	3.59	12.94	3.62	
105.8	9.73	2.77	11.44	3.49	11.78	3.53	11.95	3.56	12.12	3.57	12.51	3.6	12.57	3.65	
109.4	9.73	2.81	11.37	3.52	11.69	3.55	11.86	3.57	12.03	3.59	12.29	3.61	12.38	3.72	

**MDV-V120W/DVN1**  
**Cooling**

Combination (%) (Capacity index)	Outdoor temperature (°F DB)	Indoor temperature(°FDB/WB)													
		DB:69.4,WB:57.2		DB:73.9,WB:60.8		DB:78.4,WB:64.4		DB:80.6,WB:66.2		DB:82.7,WB:68		DB:87.3,WB:71.6		DB:89.6,WB:75.2	
		TC	PI	TC	PI	TC	PI	TC	PI	TC	PI	TC	PI	TC	PI
		kW	kW	kW	kW	kW	kW	kW	kW	kW	kW	kW	kW	kW	kW
110%	23	8.91	1.12	10.63	1.39	12.34	1.66	13.2	1.79	14.06	1.92	15.13	2	15.47	2.06
	28.4	8.91	1.14	10.63	1.41	12.34	1.68	13.2	1.8	14.06	1.94	15.13	2.02	15.47	2.07
	32	8.91	1.15	10.63	1.42	12.34	1.69	13.2	1.82	14.06	1.96	15.13	2.04	15.47	2.09
	35.6	8.91	1.18	10.63	1.43	12.34	1.72	13.2	1.84	14.06	1.98	15.13	2.07	15.47	2.12
	39.2	8.91	1.2	10.63	1.45	12.34	1.73	13.2	1.86	14.06	2.01	15.13	2.09	15.47	2.14
	42.8	8.91	1.21	10.63	1.47	12.34	1.75	13.2	1.89	14.06	2.03	15.13	2.12	15.47	2.17
	46.4	8.91	1.23	10.63	1.49	12.34	1.77	13.2	1.91	14.06	2.06	15.13	2.13	15.47	2.2
	50	8.91	1.24	10.63	1.51	12.34	1.8	13.2	1.94	14.06	2.09	15.13	2.15	15.47	2.21
	53.6	8.91	1.27	10.63	1.54	12.34	1.83	13.2	1.98	14.06	2.13	14.96	2.18	15.26	2.24
	57.2	8.91	1.29	10.63	1.57	12.34	1.87	13.2	2.01	14.06	2.17	14.74	2.19	15.09	2.26
	60.8	8.91	1.31	10.63	1.6	12.34	1.9	13.2	2.05	14.06	2.21	14.57	2.22	14.87	2.28
	64.4	8.91	1.34	10.63	1.63	12.34	1.94	13.2	2.11	14.06	2.32	14.36	2.33	14.7	2.36
	68	8.91	1.36	10.63	1.66	12.34	2.05	13.2	2.27	13.84	2.43	14.19	2.45	14.49	2.47
	69.8	8.91	1.38	10.63	1.71	12.34	2.13	13.2	2.35	13.76	2.49	14.06	2.51	14.4	2.53
	73.4	8.91	1.44	10.63	1.84	12.34	2.28	13.2	2.52	13.54	2.6	13.89	2.62	14.19	2.65
	77	8.91	1.54	10.63	1.96	12.34	2.44	13.2	2.7	13.37	2.71	13.67	2.74	14.01	2.76
	80.6	8.91	1.64	10.63	2.1	12.34	2.61	12.99	2.82	13.16	2.83	13.5	2.85	13.8	2.88
	84.2	8.91	1.75	10.63	2.24	12.34	2.79	12.81	2.93	12.99	2.94	13.29	2.97	13.63	3
	87.8	8.91	1.86	10.63	2.39	12.34	2.98	12.6	3.04	12.77	3.06	13.12	3.08	13.41	3.11
	91.4	8.91	1.98	10.63	2.55	12.26	3.14	12.43	3.16	12.6	3.17	12.9	3.2	13.24	3.23
95	8.91	2.11	10.63	2.71	12.04	3.25	12.21	3.27	12.39	3.29	12.69	3.32	13.03	3.35	
98.6	8.91	2.24	10.63	2.89	11.87	3.37	12.04	3.39	12.17	3.4	12.52	3.44	12.81	3.47	
102.2	8.91	2.38	10.63	3.08	11.66	3.49	11.83	3.5	12	3.52	12.3	3.56	12.64	3.59	
105.8	8.91	2.41	10.63	3.1	11.57	3.51	11.74	3.53	11.91	3.55	12.14	3.58	12.26	3.62	
109.4	8.91	2.43	10.63	3.14	11.47	3.54	11.65	3.55	11.82	3.57	12.04	3.59	12.07	3.69	
100%	23	8.1	1.02	9.64	1.23	11.23	1.46	12	1.57	12.77	1.7	14.36	1.94	15.17	2.02
	28.4	8.1	1.03	9.64	1.24	11.23	1.48	12	1.6	12.77	1.72	14.36	1.96	15.17	2.03
	32	8.1	1.04	9.64	1.26	11.23	1.5	12	1.62	12.77	1.74	14.36	1.99	15.17	2.06
	35.6	8.1	1.06	9.64	1.27	11.23	1.51	12	1.64	12.77	1.76	14.36	2.02	15.17	2.09
	39.2	8.1	1.07	9.64	1.29	11.23	1.53	12	1.66	12.77	1.78	14.36	2.04	15.17	2.11
	42.8	8.1	1.09	9.64	1.31	11.23	1.55	12	1.69	12.77	1.81	14.36	2.07	15.17	2.15
	46.4	8.1	1.11	9.64	1.33	11.23	1.58	12	1.71	12.77	1.84	14.36	2.1	15.17	2.18
	50	8.1	1.12	9.64	1.36	11.23	1.61	12	1.74	12.77	1.87	14.36	2.14	15.17	2.21
	53.6	8.1	1.14	9.64	1.38	11.23	1.64	12	1.77	12.77	1.91	14.36	2.18	14.96	2.23
	57.2	8.1	1.16	9.64	1.41	11.23	1.67	12	1.8	12.77	1.94	14.36	2.22	14.79	2.26
	60.8	8.1	1.18	9.64	1.44	11.23	1.7	12	1.84	12.77	1.98	14.27	2.25	14.57	2.28
	64.4	8.1	1.2	9.64	1.46	11.23	1.73	12	1.87	12.77	2.02	14.1	2.32	14.4	2.34
	68	8.1	1.23	9.64	1.49	11.23	1.79	12	1.97	12.77	2.16	13.89	2.43	14.19	2.45
	69.8	8.1	1.24	9.64	1.51	11.23	1.85	12	2.04	12.77	2.24	13.8	2.49	14.1	2.51
	73.4	8.1	1.27	9.64	1.61	11.23	1.98	12	2.19	12.77	2.4	13.63	2.6	13.89	2.62
	77	8.1	1.35	9.64	1.72	11.23	2.12	12	2.34	12.77	2.57	13.41	2.72	13.71	2.74
	80.6	8.1	1.45	9.64	1.83	11.23	2.27	12	2.51	12.77	2.75	13.2	2.83	13.5	2.86
	84.2	8.1	1.54	9.64	1.95	11.23	2.42	12	2.68	12.73	2.92	13.03	2.95	13.33	2.97
	87.8	8.1	1.64	9.64	2.08	11.23	2.58	12	2.86	12.56	3.04	12.81	3.06	13.11	3.09
	91.4	8.1	1.74	9.64	2.22	11.23	2.76	12	3.05	12.34	3.15	12.64	3.18	12.94	3.21
95	8.1	1.85	9.64	2.36	11.23	2.94	12	3.25	12.13	3.26	12.43	3.29	12.73	3.32	
98.6	8.1	1.97	9.64	2.51	11.23	3.13	11.78	3.36	11.96	3.38	12.26	3.41	12.51	3.44	
102.2	8.1	2.09	9.64	2.67	11.23	3.33	11.61	3.48	11.74	3.5	12.04	3.53	12.34	3.56	
105.8	8.1	2.19	9.64	2.77	11.23	3.46	11.43	3.5	11.65	3.55	11.83	3.61	12.16	3.63	
109.4	8.1	2.28	9.64	2.87	11.23	3.52	11.25	3.54	11.57	3.58	11.9	3.63	11.95	3.67	

**MDV-V120W/DVN1**

**Cooling**

Combination (%) (Capacity index)	Outdoor temperature (°F DB)	Indoor temperature(°FDB/WB)													
		DB:69.4,WB:57.2		DB:73.9,WB:60.8		DB:78.4,WB:64.4		DB:80.6,WB:66.2		DB:82.7,WB:68		DB:87.3,WB:71.6		DB:89.6,WB:75.2	
		TC	PI	TC	PI	TC	PI	TC	PI	TC	PI	TC	PI	TC	PI
		kW	kW	kW	kW	kW	kW	kW	kW	kW	kW	kW	kW	kW	kW
90%	23	7.29	0.9	8.7	1.08	10.11	1.28	10.8	1.39	11.49	1.48	12.9	1.7	14.31	1.95
	28.4	7.29	0.91	8.7	1.09	10.11	1.29	10.8	1.41	11.49	1.5	12.9	1.72	14.31	1.97
	32	7.29	0.92	8.7	1.11	10.11	1.31	10.8	1.43	11.49	1.52	12.9	1.74	14.31	1.99
	35.6	7.29	0.94	8.7	1.12	10.11	1.33	10.8	1.45	11.49	1.54	12.9	1.78	14.31	2.02
	39.2	7.29	0.95	8.7	1.14	10.11	1.35	10.8	1.47	11.49	1.56	12.9	1.8	14.31	2.05
	42.8	7.29	0.97	8.7	1.16	10.11	1.37	10.8	1.5	11.49	1.59	12.9	1.83	14.31	2.08
	46.4	7.29	0.98	8.7	1.18	10.11	1.4	10.8	1.52	11.49	1.62	12.9	1.87	14.31	2.1
	50	7.29	1	8.7	1.21	10.11	1.43	10.8	1.54	11.49	1.66	12.9	1.89	14.31	2.13
	53.6	7.29	1.02	8.7	1.23	10.11	1.45	10.8	1.57	11.49	1.69	12.9	1.93	14.31	2.17
	57.2	7.29	1.04	8.7	1.25	10.11	1.48	10.8	1.6	11.49	1.72	12.9	1.96	14.31	2.21
	60.8	7.29	1.06	8.7	1.27	10.11	1.51	10.8	1.63	11.49	1.75	12.9	2	14.27	2.25
	64.4	7.29	1.07	8.7	1.3	10.11	1.54	10.8	1.66	11.49	1.79	12.9	2.04	14.1	2.32
	68	7.29	1.09	8.7	1.33	10.11	1.57	10.8	1.69	11.49	1.85	12.9	2.19	13.89	2.43
	69.8	7.29	1.09	8.7	1.33	10.11	1.57	10.8	1.69	11.49	1.85	12.9	2.19	13.89	2.43
	73.4	7.29	1.1	8.7	1.34	10.11	1.59	10.8	1.75	11.49	1.92	12.9	2.27	13.8	2.49
	77	7.29	1.13	8.7	1.39	10.11	1.71	10.8	1.88	11.49	2.06	12.9	2.44	13.59	2.6
	80.6	7.29	1.19	8.7	1.49	10.11	1.83	10.8	2.01	11.49	2.2	12.9	2.61	13.41	2.72
	84.2	7.29	1.26	8.7	1.59	10.11	1.95	10.8	2.15	11.49	2.35	12.9	2.79	13.2	2.83
	87.8	7.29	1.34	8.7	1.69	10.11	2.08	10.8	2.29	11.49	2.51	12.77	2.92	13.03	2.94
	91.4	7.29	1.43	8.7	1.8	10.11	2.22	10.8	2.44	11.49	2.68	12.56	3.04	12.81	3.06
95	7.29	1.52	8.7	1.91	10.11	2.37	10.8	2.61	11.49	2.86	12.39	3.15	12.64	3.18	
98.6	7.29	1.61	8.7	2.04	10.11	2.52	10.8	2.78	11.49	3.05	12.17	3.27	12.43	3.29	
102.2	7.29	1.71	8.7	2.16	10.11	2.68	10.8	2.96	11.49	3.25	11.96	3.38	12.26	3.41	
105.8	7.29	1.81	8.7	2.3	10.11	2.85	10.8	3.15	11.49	3.46	11.79	3.5	12.04	3.53	
109.4	7.29	1.88	8.7	2.41	10.11	2.96	10.8	3.23	11.49	3.48	11.7	3.59	11.96	3.61	
80%	23	7.29	2.21	8.7	2.76	10.11	3.3	10.8	3.47	11.49	3.69	12.76	3.72	12.62	3.76
	28.4	6.47	0.8	7.71	0.94	8.96	1.11	9.6	1.18	10.24	1.27	11.49	1.47	12.73	1.68
	32	6.47	0.81	7.71	0.95	8.96	1.12	9.6	1.2	10.24	1.29	11.49	1.49	12.73	1.7
	35.6	6.47	0.82	7.71	0.96	8.96	1.14	9.6	1.22	10.24	1.31	11.49	1.51	12.73	1.72
	39.2	6.47	0.84	7.71	0.98	8.96	1.15	9.6	1.24	10.24	1.33	11.49	1.54	12.73	1.75
	42.8	6.47	0.85	7.71	0.99	8.96	1.17	9.6	1.27	10.24	1.36	11.49	1.57	12.73	1.78
	46.4	6.47	0.87	7.71	1.02	8.96	1.19	9.6	1.3	10.24	1.38	11.49	1.59	12.73	1.81
	50	6.47	0.88	7.71	1.04	8.96	1.22	9.6	1.32	10.24	1.41	11.49	1.61	12.73	1.84
	53.6	6.47	0.89	7.71	1.06	8.96	1.25	9.6	1.35	10.24	1.45	11.49	1.65	12.73	1.86
	57.2	6.47	0.9	7.71	1.08	8.96	1.27	9.6	1.38	10.24	1.48	11.49	1.68	12.73	1.9
	60.8	6.47	0.92	7.71	1.1	8.96	1.3	9.6	1.4	10.24	1.5	11.49	1.71	12.73	1.93
	64.4	6.47	0.93	7.71	1.12	8.96	1.32	9.6	1.42	10.24	1.53	11.49	1.75	12.73	1.97
	68	6.47	0.95	7.71	1.14	8.96	1.35	9.6	1.45	10.24	1.56	11.49	1.78	12.73	2.01
	69.8	6.47	0.97	7.71	1.17	8.96	1.38	9.6	1.48	10.24	1.59	11.49	1.85	12.73	2.15
	73.4	6.47	0.98	7.71	1.17	8.96	1.39	9.6	1.5	10.24	1.63	11.49	1.91	12.73	2.23
	77	6.47	0.99	7.71	1.2	8.96	1.45	9.6	1.59	10.24	1.74	11.49	2.05	12.73	2.39
	80.6	6.47	1.02	7.71	1.27	8.96	1.55	9.6	1.7	10.24	1.86	11.49	2.19	12.73	2.55
	84.2	6.47	1.09	7.71	1.36	8.96	1.66	9.6	1.82	10.24	1.98	11.49	2.34	12.73	2.73
	87.8	6.47	1.16	7.71	1.45	8.96	1.77	9.6	1.94	10.24	2.12	11.49	2.5	12.73	2.92
	91.4	6.47	1.23	7.71	1.54	8.96	1.88	9.6	2.06	10.24	2.26	11.49	2.67	12.51	3.04
95	6.47	1.31	7.71	1.63	8.96	2	9.6	2.2	10.24	2.4	11.49	2.85	12.34	3.15	
98.6	6.47	1.39	7.71	1.74	8.96	2.13	9.6	2.34	10.24	2.56	11.49	3.04	12.13	3.26	
102.2	6.47	1.47	7.71	1.84	8.96	2.26	9.6	2.49	10.24	2.73	11.49	3.24	11.96	3.38	
105.8	6.47	1.56	7.71	1.97	8.96	2.41	9.6	2.65	10.24	2.9	11.49	3.45	11.74	3.5	
109.4	6.47	1.59	7.71	1.98	8.96	2.44	9.6	2.72	10.24	2.96	11.49	3.53	11.67	3.56	

**MDV-V120W/DVN1**  
**Cooling**

Combination (%) (Capacity index)	Outdoor temperature (°F DB)	Indoor temperature(°FDB/WB)													
		DB:69.4,WB:57.2		DB:73.9,WB:60.8		DB:78.4,WB:64.4		DB:80.6,WB:66.2		DB:82.7,WB:68		DB:87.3,WB:71.6		DB:89.6,WB:75.2	
		TC	PI	TC	PI	TC	PI	TC	PI	TC	PI	TC	PI	TC	PI
		kW	kW	kW	kW	kW	kW	kW	kW	kW	kW	kW	kW	kW	kW
70%	23	6.47	1.74	7.71	2.04	10.08	2.57	9.6	2.86	10.24	3.08	11.49	3.65	12.78	3.7
	28.4	5.66	0.71	6.77	0.83	7.84	0.94	8.4	1.01	8.96	1.08	10.03	1.23	11.14	1.42
	32	5.66	0.72	6.77	0.84	7.84	0.95	8.4	1.03	8.96	1.1	10.03	1.25	11.14	1.44
	35.6	5.66	0.72	6.77	0.85	7.84	0.97	8.4	1.05	8.96	1.12	10.03	1.28	11.14	1.46
	39.2	5.66	0.72	6.77	0.85	7.84	0.98	8.4	1.07	8.96	1.14	10.03	1.31	11.14	1.48
	42.8	5.66	0.73	6.77	0.87	7.84	1.01	8.4	1.09	8.96	1.16	10.03	1.33	11.14	1.52
	46.4	5.66	0.74	6.77	0.89	7.84	1.03	8.4	1.12	8.96	1.19	10.03	1.35	11.14	1.55
	50	5.66	0.76	6.77	0.91	7.84	1.05	8.4	1.14	8.96	1.22	10.03	1.39	11.14	1.58
	53.6	5.66	0.77	6.77	0.93	7.84	1.08	8.4	1.17	8.96	1.25	10.03	1.42	11.14	1.59
	57.2	5.66	0.79	6.77	0.94	7.84	1.1	8.4	1.19	8.96	1.27	10.03	1.45	11.14	1.63
	60.8	5.66	0.81	6.77	0.96	7.84	1.12	8.4	1.2	8.96	1.29	10.03	1.47	11.14	1.66
	64.4	5.66	0.82	6.77	0.98	7.84	1.14	8.4	1.23	8.96	1.32	10.03	1.5	11.14	1.69
	68	5.66	0.83	6.77	0.99	7.84	1.17	8.4	1.25	8.96	1.34	10.03	1.53	11.14	1.72
	69.8	5.66	0.85	6.77	1.01	7.84	1.19	8.4	1.27	8.96	1.37	10.03	1.56	11.14	1.77
	73.4	5.66	0.85	6.77	1.02	7.84	1.2	8.4	1.29	8.96	1.38	10.03	1.58	11.14	1.83
	77	5.66	0.87	6.77	1.04	7.84	1.22	8.4	1.33	8.96	1.45	10.03	1.7	11.14	1.96
	80.6	5.66	0.88	6.77	1.08	7.84	1.3	8.4	1.42	8.96	1.55	10.03	1.81	11.14	2.1
	84.2	5.66	0.94	6.77	1.15	7.84	1.39	8.4	1.52	8.96	1.65	10.03	1.94	11.14	2.24
	87.8	5.66	0.99	6.77	1.22	7.84	1.48	8.4	1.62	8.96	1.76	10.03	2.06	11.14	2.4
	91.4	5.66	1.05	6.77	1.3	7.84	1.57	8.4	1.72	8.96	1.87	10.03	2.2	11.14	2.55
95	5.66	1.12	6.77	1.38	7.84	1.67	8.4	1.83	8.96	1.99	10.03	2.34	11.14	2.72	
98.6	5.66	1.25	6.77	1.55	7.84	1.89	8.4	2.06	8.96	2.26	10.03	2.66	11.14	3.09	
102.2	5.66	1.32	6.77	1.64	7.84	2	8.4	2.19	8.96	2.4	10.03	2.83	11.14	3.29	
105.8	5.66	1.38	6.77	1.7	7.84	2.06	8.4	2.27	8.96	2.47	10.03	2.94	11.14	3.44	
109.4	5.66	1.49	6.77	1.82	7.84	2.14	8.4	2.39	8.96	2.54	10.03	3.05	11.14	3.55	
60%	23	4.84	0.61	5.79	0.7	6.73	0.82	7.2	0.87	7.67	0.94	8.61	1.06	9.56	1.21
	28.4	4.84	0.61	5.79	0.71	6.73	0.83	7.2	0.88	7.67	0.95	8.61	1.07	9.56	1.22
	32	4.84	0.62	5.79	0.72	6.73	0.84	7.2	0.9	7.67	0.97	8.61	1.09	9.56	1.24
	35.6	4.84	0.63	5.79	0.74	6.73	0.86	7.2	0.91	7.67	0.98	8.61	1.11	9.56	1.25
	39.2	4.84	0.65	5.79	0.75	6.73	0.88	7.2	0.92	7.67	0.99	8.61	1.13	9.56	1.27
	42.8	4.84	0.65	5.79	0.77	6.73	0.89	7.2	0.94	7.67	1.01	8.61	1.15	9.56	1.3
	46.4	4.84	0.67	5.79	0.78	6.73	0.91	7.2	0.96	7.67	1.04	8.61	1.17	9.56	1.32
	50	4.84	0.68	5.79	0.8	6.73	0.92	7.2	0.99	7.67	1.06	8.61	1.2	9.56	1.34
	53.6	4.84	0.69	5.79	0.81	6.73	0.94	7.2	1.01	7.67	1.07	8.61	1.22	9.56	1.36
	57.2	4.84	0.7	5.79	0.82	6.73	0.95	7.2	1.02	7.67	1.09	8.61	1.24	9.56	1.39
	60.8	4.84	0.71	5.79	0.84	6.73	0.97	7.2	1.04	7.67	1.11	8.61	1.26	9.56	1.41
	64.4	4.84	0.72	5.79	0.85	6.73	0.99	7.2	1.06	7.67	1.13	8.61	1.28	9.56	1.44
	68	4.84	0.73	5.79	0.87	6.73	1.01	7.2	1.08	7.67	1.16	8.61	1.31	9.56	1.47
	69.8	4.84	0.74	5.79	0.87	6.73	1.02	7.2	1.09	7.67	1.16	8.61	1.32	9.56	1.48
	73.4	4.84	0.75	5.79	0.89	6.73	1.03	7.2	1.11	7.67	1.19	8.61	1.38	9.56	1.58
	77	4.84	0.76	5.79	0.9	6.73	1.07	7.2	1.16	7.67	1.26	8.61	1.47	9.56	1.69
	80.6	4.84	0.79	5.79	0.96	6.73	1.14	7.2	1.24	7.67	1.34	8.61	1.56	9.56	1.8
	84.2	4.84	0.84	5.79	1.02	6.73	1.22	7.2	1.32	7.67	1.43	8.61	1.67	9.56	1.92
	87.8	4.84	0.89	5.79	1.08	6.73	1.29	7.2	1.41	7.67	1.52	8.61	1.77	9.56	2.05
	91.4	4.84	0.94	5.79	1.14	6.73	1.37	7.2	1.49	7.67	1.62	8.61	1.89	9.56	2.18
95	4.84	0.99	5.79	1.21	6.73	1.45	7.2	1.59	7.67	1.72	8.61	2.01	9.56	2.32	
98.6	4.84	1.05	5.79	1.28	6.73	1.54	7.2	1.68	7.67	1.83	8.61	2.14	9.56	2.47	
102.2	4.84	1.11	5.79	1.36	6.73	1.63	7.2	1.78	7.67	1.94	8.61	2.27	9.56	2.63	
105.8	4.84	1.14	5.79	1.42	6.73	1.69	7.2	1.85	7.67	2.01	8.61	2.38	9.56	2.75	
109.4	4.84	1.18	5.79	1.48	6.73	1.75	7.2	1.91	7.67	2.08	8.61	2.48	9.56	2.87	



**MDV-V120W/DVN1**

**Cooling**

Combination (%) (Capacity index)	Outdoor temperature (°F DB)	Indoor temperature(°FDB/WB)													
		DB:69.4,WB:57.2		DB:73.9,WB:60.8		DB:78.4,WB:64.4		DB:80.6,WB:66.2		DB:82.7,WB:68		DB:87.3,WB:71.6		DB:89.6,WB:75.2	
		TC	PI	TC	PI	TC	PI	TC	PI	TC	PI	TC	PI	TC	PI
		kW	kW	kW	kW	kW	kW	kW	kW	kW	kW	kW	kW	kW	kW
50%	23	4.05	0.53	4.84	0.61	5.61	0.7	6	0.73	6.39	0.77	7.16	0.88	7.97	0.95
	28.4	4.05	0.53	4.84	0.62	5.61	0.71	6	0.74	6.39	0.79	7.16	0.89	7.97	0.96
	32	4.05	0.54	4.84	0.63	5.61	0.72	6	0.75	6.39	0.79	7.16	0.9	7.97	0.98
	35.6	4.05	0.55	4.84	0.64	5.61	0.73	6	0.76	6.39	0.81	7.16	0.91	7.97	0.99
	39.2	4.05	0.55	4.84	0.65	5.61	0.74	6	0.77	6.39	0.82	7.16	0.93	7.97	1.02
	42.8	4.05	0.56	4.84	0.66	5.61	0.75	6	0.79	6.39	0.84	7.16	0.95	7.97	1.05
	46.4	4.05	0.58	4.84	0.67	5.61	0.76	6	0.81	6.39	0.85	7.16	0.96	7.97	1.08
	50	4.05	0.59	4.84	0.68	5.61	0.78	6	0.82	6.39	0.88	7.16	0.99	7.97	1.1
	53.6	4.05	0.59	4.84	0.69	5.61	0.79	6	0.84	6.39	0.89	7.16	1	7.97	1.12
	57.2	4.05	0.6	4.84	0.7	5.61	0.8	6	0.85	6.39	0.91	7.16	1.02	7.97	1.14
	60.8	4.05	0.61	4.84	0.71	5.61	0.81	6	0.87	6.39	0.92	7.16	1.04	7.97	1.16
	64.4	4.05	0.62	4.84	0.72	5.61	0.82	6	0.88	6.39	0.94	7.16	1.06	7.97	1.18
	68	4.05	0.63	4.84	0.73	5.61	0.84	6	0.89	6.39	0.95	7.16	1.07	7.97	1.2
	69.8	4.05	0.63	4.84	0.74	5.61	0.85	6	0.9	6.39	0.96	7.16	1.09	7.97	1.21
	73.4	4.05	0.64	4.84	0.74	5.61	0.86	6	0.92	6.39	0.98	7.16	1.1	7.97	1.24
	77	4.05	0.65	4.84	0.76	5.61	0.88	6	0.94	6.39	1.01	7.16	1.16	7.97	1.32
	80.6	4.05	0.66	4.84	0.79	5.61	0.92	6	1	6.39	1.07	7.16	1.24	7.97	1.41
	84.2	4.05	0.7	4.84	0.83	5.61	0.98	6	1.06	6.39	1.14	7.16	1.31	7.97	1.5
	87.8	4.05	0.74	4.84	0.88	5.61	1.04	6	1.13	6.39	1.21	7.16	1.4	7.97	1.6
	91.4	4.05	0.78	4.84	0.93	5.61	1.1	6	1.19	6.39	1.29	7.16	1.48	7.97	1.7
95	4.05	0.82	4.84	0.99	5.61	1.16	6	1.26	6.39	1.36	7.16	1.58	7.97	1.8	
98.6	4.05	0.87	4.84	1.04	5.61	1.24	6	1.34	6.39	1.45	7.16	1.67	7.97	1.92	
102.2	4.05	0.92	4.84	1.1	5.61	1.31	6	1.41	6.39	1.53	7.16	1.77	7.97	2.04	
105.8	4.05	0.95	4.84	1.15	5.61	1.35	6	1.48	6.39	1.6	7.16	1.87	7.97	2.13	
109.4	4.05	1.02	4.84	1.23	5.61	1.4	6	1.55	6.39	1.64	7.16	1.96	7.97	2.23	

**Note:**

1. [ ] is tested under our standard condition.
2. Avoid to run the unit when the temperature is above 109.4°F (43°C).
3. The above table shows the average value of conditions may operate.
4. It is recommended to connect less than 130%.

**MDV-V120W/DVN1**  
**Heating**

Combination (%) (Capacity index)	Outdoor Air temperature(°F)		Indoor temperature(°F WB)											
			60.8		64.4		68		69.8		71.6		75.2	
	°F DB	°F WB	TC	PI	TC	PI	TC	PI	TC	PI	TC	PI	TC	PI
130%	7.34	5	9.39	3.14	9.35	3.32	9.3	3.5	9.3	3.59	9.26	3.68	9.26	3.86
	10.76	8.6	9.76	3.28	9.76	3.45	9.72	3.62	9.68	3.71	9.68	3.8	9.64	3.97
	14.36	12.2	10.23	3.42	10.18	3.59	10.14	3.75	10.14	3.84	10.14	3.92	10.1	4.08
	14.9	14	10.48	3.5	10.43	3.66	10.39	3.82	10.39	3.9	10.35	3.98	10.35	4.13
	16.7	15.62	10.68	3.56	10.64	3.71	10.64	3.87	10.6	3.95	10.6	4.03	10.56	4.19
	19.4	18.32	11.06	3.66	11.06	3.82	11.02	3.96	11.02	4.04	10.98	4.11	10.94	4.27
	23	21.92	11.65	3.8	11.61	3.94	11.56	4.09	11.56	4.16	11.52	4.23	11.52	4.37
	26.6	25.34	12.19	3.92	12.15	4.06	12.15	4.2	12.11	4.27	12.11	4.34	12.07	4.47
	32	30.74	13.16	4.11	13.16	4.24	13.12	4.37	13.12	4.41	13.07	4.5	13.07	4.62
	37.4	35.96	14.2	4.28	14.16	4.4	14.12	4.52	14.12	4.58	14.12	4.64	14.08	4.75
	41	39.38	14.92	4.39	14.88	4.51	14.88	4.61	14.83	4.67	14.83	4.73	14.79	4.84
	44.6	42.8	15.67	4.5	15.63	4.6	15.63	4.71	15.59	4.76	15.59	4.81	14.96	4.62
	48.2	46.22	16.47	4.59	16.43	4.69	16.43	4.79	16.39	4.84	16.05	4.74	14.96	4.34
	51.8	49.64	17.31	4.68	17.27	4.77	17.18	4.84	16.59	4.65	16.05	4.45	14.96	4.09
	55.4	53.24	18.23	4.77	18.19	4.86	17.18	4.53	16.59	4.35	16.05	4.18	14.96	3.84
	59	56.66	19.11	4.85	18.27	4.6	17.18	4.27	16.59	4.1	16.05	3.94	14.96	3.62
120%	7.34	5	9.35	3.38	9.3	3.55	9.26	3.71	9.26	3.8	9.26	3.88	9.22	4.05
	10.76	8.6	9.72	3.51	9.72	3.67	9.68	3.83	9.68	3.91	9.64	3.99	9.64	4.15
	14.36	12.2	10.18	3.65	10.14	3.79	10.14	3.95	10.1	4.03	10.1	4.1	10.06	4.25
	14.9	14	10.44	3.71	10.39	3.86	10.35	4.01	10.35	4.08	10.35	4.16	10.31	4.3
	16.7	15.62	10.64	3.77	10.6	3.91	10.6	4.06	10.56	4.13	10.56	4.21	10.52	4.35
	19.4	18.32	11.02	3.87	11.02	4.01	10.98	4.15	10.98	4.22	10.94	4.28	10.94	4.42
	23	21.92	11.61	3.99	11.57	4.12	11.52	4.26	11.52	4.33	11.52	4.39	11.48	4.52
	26.6	25.34	12.15	4.11	12.15	4.24	12.11	4.36	12.11	4.42	12.07	4.49	12.07	4.61
	32	30.74	13.12	4.28	13.12	4.4	13.07	4.52	13.07	4.58	13.03	4.63	13.03	4.75
	37.4	35.96	14.16	4.44	14.12	4.55	14.12	4.66	14.08	4.72	14.08	4.77	13.79	4.74
	41	39.38	14.88	4.54	14.83	4.65	14.83	4.75	14.79	4.8	14.79	4.85	13.79	4.45
	44.6	42.8	15.63	4.63	15.63	4.73	15.59	4.83	15.34	4.76	14.83	4.57	13.79	4.19
	48.2	46.22	16.43	4.73	16.39	4.82	15.84	4.66	15.34	4.48	14.83	4.29	13.79	3.94
	51.8	49.64	17.27	4.81	16.85	4.73	15.84	4.38	15.34	4.21	14.83	4.04	13.79	3.72
	55.4	53.24	17.89	4.76	16.85	4.43	15.84	4.11	15.34	3.95	14.83	3.8	13.79	3.5
	59	56.66	17.89	4.49	16.85	4.18	15.84	3.88	15.34	3.73	14.83	3.58	13.79	3.3
110%	7.34	5	9.3	3.62	9.26	3.78	9.22	3.93	9.22	4.01	9.22	4.08	9.18	4.23
	10.76	8.6	9.68	3.75	9.68	3.89	9.64	4.04	9.64	4.11	9.6	4.18	9.6	4.33
	14.36	12.2	10.14	3.87	10.1	4.01	10.1	4.15	10.06	4.22	10.06	4.28	10.06	4.42
	14.9	14	10.39	3.93	10.35	4.06	10.31	4.2	10.31	4.27	10.31	4.34	10.27	4.47
	16.7	15.62	10.6	3.98	10.56	4.11	10.56	4.25	10.52	4.32	10.52	4.38	10.52	4
	19.4	18.32	10.98	4.07	10.98	4.2	10.94	4.33	10.94	4.39	10.94	4.45	10.9	4.58
	23	21.92	11.57	4.19	11.52	4.31	11.48	4.43	11.48	4.49	11.48	4.55	11.44	4.68
	26.6	25.34	12.11	4.29	12.11	4.41	12.07	4.53	12.07	4.58	12.03	4.64	12.03	4.76
	32	30.74	13.07	4.45	13.07	4.56	13.03	4.67	13.03	4.72	13.03	4.78	12.66	4.69
	37.4	35.96	14.12	4.6	14.08	4.7	14.08	4.8	14.04	4.85	13.58	4.65	12.66	4.26
	41	39.38	14.83	4.69	14.83	4.79	14.54	4.74	14.04	4.55	13.58	4.37	12.66	4.01
	44.6	42.8	15.59	4.78	15.46	4.81	14.54	4.45	14.04	4.28	13.58	4.11	12.66	3.77
	48.2	46.22	16.38	4.86	15.46	4.52	14.54	4.19	14.04	4.03	13.58	3.87	12.66	3.56
	51.8	49.64	16.38	4.57	15.46	4.25	14.54	3.94	14.04	3.79	13.58	3.65	12.66	3.36
	55.4	53.24	16.38	4.28	15.46	3.99	14.54	3.71	14.04	3.57	13.58	3.43	12.66	3.16
	59	56.66	16.38	3.81	15.46	3.76	14.54	3.5	14.04	3.37	13.58	3.24	12.66	2.99

**MDV-V120W/DVN1**  
**Heating**

Combination (%) (Capacity index)	Outdoor Air temperature(°F)		Indoor temperature(°F WB)											
			60.8		64.4		68		69.8		71.6		75.2	
	°F DB	°F WB	TC	PI	TC	PI	TC	PI	TC	PI	TC	PI	TC	PI
100%	7.34	5	9.26	3.87	9.22	4.01	9.18	4.15	9.18	4.22	9.18	4.28	9.14	4.42
	10.76	8.6	9.64	3.98	9.64	4.11	9.6	4.24	9.6	4.31	9.6	4.38	9.55	4.51
	14.36	12.2	10.1	4.09	10.06	4.22	10.06	4.34	10.06	4.41	10.01	4.47	10.01	4.59
	14.9	14	10.35	4.15	10.31	4.27	10.31	4.39	10.27	4.45	10.27	4.52	10.22	4.64
	16.7	15.62	10.56	4.19	10.52	4.32	10.52	4.43	10.52	4.5	10.48	4.56	10.48	4.68
	19.4	18.32	10.94	4.27	10.94	4.39	10.9	4.51	10.9	4.57	10.9	4.62	10.85	4.74
	23	21.92	11.52	4.38	11.48	4.49	11.48	4.6	11.44	4.66	11.44	4.71	11.4	4.83
	26.6	25.34	12.07	4.48	12.07	4.07	12.03	4.69	12.03	4.74	12.03	4.79	11.52	4.59
	32	30.74	13.03	4.62	13.03	4.72	12.99	4.82	12.78	4.74	12.36	4.55	11.52	4.17
	37.4	35.96	14.08	4.76	14.04	4.85	13.2	4.49	12.78	4.31	12.36	4.14	11.52	3.8
	41	39.38	14.79	4.85	14.04	4.55	13.2	4.22	12.78	4.06	12.36	3.9	11.52	3.58
	44.6	42.8	14.88	4.6	14.04	4.28	13.2	3.97	12.78	3.82	12.36	3.67	11.52	3.38
	48.2	46.22	14.88	4.32	14.04	4.03	13.2	3.74	12.78	3.55	12.36	3.46	11.52	3.19
	51.8	49.64	14.88	4.07	14.04	3.79	13.2	3.53	12.78	3.39	12.36	3.26	11.52	3.01
	55.4	53.24	14.88	3.82	14.04	3.57	13.2	3.32	12.78	3.2	12.36	3.08	11.52	2.84
	59	56.66	14.88	3.6	14.04	3.37	13.2	3.13	12.78	3.02	12.36	2.91	11.52	2.69
90%	7.34	5	9.2	4.11	9.16	4.24	9.16	4.36	9.12	4.42	9.12	4.49	9.12	4.61
	10.76	8.6	9.58	4.21	9.58	4.33	9.54	4.45	9.54	4.51	9.54	4.57	9.5	4.69
	14.36	12.2	10.04	4.31	10.04	4.42	10	4.54	10	4.59	10	4.66	9.96	4.77
	14.9	14	10.29	4.36	10.25	4.48	10.25	4.58	10.21	4.64	10.21	4.7	10.21	4.81
	16.7	15.62	10.5	4.41	10.5	4.52	10.46	4.62	10.46	4.68	10.46	4.73	10.33	4.78
	19.4	18.32	10.88	4.48	10.88	4.58	10.83	4.69	10.83	4.74	10.83	4.79	10.33	4.56
	23	21.92	11.46	4.58	11.42	4.68	11.42	4.77	11.38	4.83	11.09	4.68	10.33	4.29
	26.6	25.34	12.01	4.67	12.01	4.76	11.88	4.78	11.46	4.59	11.09	4.4	10.33	4.04
	32	30.74	13.01	4.8	12.63	4.68	11.88	4.34	11.46	4.17	11.09	4	10.33	3.68
	37.4	35.96	13.39	4.57	12.63	4.26	11.88	3.95	11.46	3.8	11.09	3.65	10.33	3.36
	41	39.38	13.39	4.3	12.63	4.01	11.88	3.72	11.46	3.58	11.09	3.44	10.33	3.17
	44.6	42.8	13.39	4.04	12.63	3.77	11.88	3.51	11.46	3.38	11.09	3.25	10.33	3
	48.2	46.22	13.39	3.81	12.63	3.55	11.88	3.3	11.46	3.19	11.09	3.07	10.33	2.83
	51.8	49.64	13.39	3.59	12.63	3.35	11.88	3.12	11.46	3.01	11.09	2.9	10.33	2.68
	55.4	53.24	13.39	3.38	12.63	3.16	11.88	2.94	11.46	2.84	11.09	2.74	10.33	2.53
	59	56.66	13.39	3.19	12.63	2.99	11.88	2.79	11.46	2.69	11.09	2.59	10.33	2.4
80%	7.34	5	9.18	4.36	9.14	4.46	9.14	4.58	9.14	4.63	9.09	4.69	9.09	4.8
	10.76	8.6	9.55	4.44	9.55	4.55	9.51	4.66	9.51	4.71	9.51	4.76	9.22	4.64
	14.36	12.2	10.02	4.53	10.02	4.64	9.97	4.74	9.97	4.78	9.89	4.77	9.22	4.38
	14.9	14	10.27	4.58	10.22	4.68	10.23	4.77	10.23	4.83	9.89	4.64	9.22	4.25
	16.7	15.62	10.48	4.62	9.74	4.72	10.43	4.81	10.23	4.7	9.89	4.51	9.22	4.13
	19.4	18.32	10.85	4.69	10.85	4.78	10.56	4.68	10.23	4.49	9.89	4.31	9.22	3.95
	23	21.92	11.44	4.77	11.23	4.74	10.56	4.39	10.23	4.22	9.89	4.05	9.22	3.72
	26.6	25.34	11.9	4.79	11.23	4.46	10.56	4.13	10.23	3.98	9.89	3.82	9.22	3.52
	32	30.74	11.9	4.35	11.23	4.05	10.56	3.76	10.23	3.62	9.89	3.48	9.22	3.21
	37.4	35.96	11.9	3.96	11.23	3.7	10.56	3.44	10.23	3.31	9.89	3.19	9.22	2.94
	41	39.38	11.9	3.73	11.23	3.49	10.56	3.24	10.23	3.12	9.89	3.01	9.22	2.78
	44.6	42.8	11.9	3.52	11.23	3.29	10.56	3.06	10.23	2.95	9.89	2.85	9.22	2.63
	48.2	46.22	11.9	3.32	11.23	3.1	10.56	2.89	10.23	2.79	9.89	2.69	9.22	2.49
	51.8	49.64	11.9	3.13	11.23	2.93	10.56	2.74	10.23	2.64	9.89	2.55	9.22	2.36
	55.4	53.24	11.9	2.95	11.23	2.77	10.56	2.59	10.23	2.5	9.89	2.41	9.22	2.23
	59	56.66	11.9	2.79	11.23	2.62	10.56	2.45	10.23	2.37	9.89	2.28	9.22	2.12

**MDV-V120W/DVN1**

**Heating**

Combination (%) (Capacity index)	Outdoor Air temperature(°F)		Indoor temperature(°F WB)											
			60.8		64.4		68		69.8		71.6		75.2	
			TC	PI	TC	PI	TC	PI	TC	PI	TC	PI	TC	PI
	°F DB	°F WB	kW	kW	kW	kW	kW	kW	kW	kW	kW	kW	kW	kW
70%	7.34	5	9.11	4.6	9.07	4.7	9.07	4.79	8.91	4.72	8.61	4.53	8.03	4.16
	10.76	8.6	9.49	4.68	9.49	4.77	9.24	4.66	8.91	4.48	8.61	4.29	8.03	3.94
	14.36	12.2	9.95	4.75	9.82	4.75	9.24	4.4	8.91	4.23	8.61	4.06	8.03	3.73
	14.9	14	10.2	4.79	9.82	4.61	9.24	4.27	8.91	4.1	8.61	3.94	8.03	3.62
	16.7	15.62	10.41	4.82	9.82	4.49	9.24	4.16	8.91	4	8.61	3.84	8.03	3.53
	19.4	18.32	10.41	4.6	9.82	4.28	9.24	3.98	8.91	3.83	8.61	3.68	8.03	3.38
	23	21.92	10.41	4.33	9.82	4.03	9.24	3.74	8.91	3.6	8.61	4.25	8.03	3.19
	26.6	25.34	10.41	4.07	9.82	3.8	9.24	3.53	8.91	3.4	8.61	3.27	8.03	3.02
	32	30.74	10.41	3.71	9.82	3.46	9.24	3.22	8.91	3.1	8.61	2.99	8.03	2.76
	37.4	35.96	10.41	3.39	9.82	3.17	9.24	2.95	8.91	2.85	8.61	2.74	8.03	2.54
	41	39.38	10.41	3.2	9.82	2.99	9.24	2.79	8.91	2.69	8.61	2.59	8.03	2.4
	44.6	42.8	10.41	3.02	9.82	2.83	9.24	2.64	8.91	2.55	8.61	2.46	8.03	2.28
	48.2	46.22	10.41	2.86	9.82	2.68	9.24	2.5	8.91	2.41	8.61	2.33	8.03	2.16
	51.8	49.64	10.41	2.7	9.82	2.53	9.24	2.37	8.91	2.29	8.61	2.21	8.03	2.05
	55.4	53.24	10.41	2.55	9.82	2.4	9.24	2.24	8.91	2.17	8.61	2.09	8.03	1.95
59	56.66	10.41	2.42	9.82	2.27	9.24	2.13	8.91	2.06	8.61	1.99	8.03	1.86	
60%	7.34	5	8.93	4.72	8.42	4.39	7.92	4.07	7.67	3.92	7.42	3.76	6.91	3.46
	10.76	8.6	8.93	4.47	8.42	4.16	7.92	3.86	7.67	3.72	7.42	3.57	6.91	3.3
	14.36	12.2	8.93	4.22	8.42	3.93	7.92	3.66	7.67	3.52	7.42	3.38	6.91	3.12
	14.9	14	8.93	4.1	8.42	3.83	7.92	3.55	7.67	3.42	7.42	3.29	6.91	3.03
	16.7	15.62	8.93	4	8.42	3.73	7.92	3.46	7.67	3.34	7.42	3.21	6.91	2.96
	19.4	18.32	8.93	3.82	8.42	3.57	7.92	3.32	7.67	3.2	7.42	3.07	6.91	2.84
	23	21.92	8.93	3.6	8.42	3.36	7.92	3.13	7.67	3.02	7.42	2.9	6.91	2.69
	26.6	25.34	8.93	3.4	8.42	3.18	7.92	2.96	7.67	2.86	7.42	2.75	6.91	2.54
	32	30.74	8.93	3.1	8.42	2.91	7.92	2.71	7.67	2.62	7.42	2.52	6.91	2.34
	37.4	35.96	8.93	2.85	8.42	2.67	7.92	2.5	7.67	2.41	7.42	2.33	6.91	2.15
	41	39.38	8.93	2.69	8.42	2.53	7.92	2.36	7.67	2.28	7.42	2.2	6.91	2.05
	44.6	42.8	8.93	2.55	8.42	2.39	7.92	2.24	7.67	2.17	7.42	2.09	6.91	1.94
	48.2	46.22	8.93	2.41	8.42	2.27	7.92	2.12	7.67	2.06	7.42	1.98	6.91	1.85
	51.8	49.64	8.93	2.29	8.42	2.15	7.92	2.02	7.67	1.95	7.42	1.89	6.91	1.76
	55.4	53.24	8.93	2.17	8.42	2.04	7.92	1.92	7.67	1.86	7.42	1.79	6.91	1.68
59	56.66	8.93	2.06	8.42	1.94	7.92	1.83	7.67	1.77	7.42	1.71	6.91	1.6	
50%	7.34	5	7.44	3.78	7.02	3.53	6.6	3.28	6.35	3.17	6.14	3.05	5.72	2.81
	10.76	8.6	7.44	3.59	7.02	3.36	6.6	3.12	6.35	3.01	6.14	2.9	5.72	2.68
	14.36	12.2	7.44	3.4	7.02	3.18	6.6	2.96	6.35	2.86	6.14	2.75	5.72	2.55
	14.9	14	7.44	3.31	7.02	3.09	6.6	2.89	6.35	2.78	6.14	2.68	5.72	2.48
	16.7	15.62	7.44	3.23	7.02	3.02	6.6	2.81	6.35	2.72	6.14	2.62	5.72	2.42
	19.4	18.32	7.44	3.09	7.02	2.9	6.6	2.7	6.35	2.61	6.14	2.52	5.72	2.33
	23	21.92	7.44	2.92	7.02	2.74	6.6	2.56	6.35	2.47	6.14	2.38	5.72	2.21
	26.6	25.34	7.44	2.76	7.02	2.59	6.6	2.42	6.35	2.34	6.14	2.26	5.72	2.1
	32	30.74	7.44	2.54	7.02	2.38	6.6	2.23	6.35	2.16	6.14	2.08	5.72	1.94
	37.4	35.96	7.44	2.34	7.02	2.2	6.6	2.06	6.35	1.99	6.14	1.92	5.72	1.79
	41	39.38	7.44	2.22	7.02	2.08	6.6	1.95	6.35	1.89	6.14	1.83	5.72	1.71
	44.6	42.8	7.44	2.1	7.02	1.98	6.6	1.86	6.35	1.8	6.14	1.74	5.72	1.63
	48.2	46.22	7.44	2	7.02	1.88	6.6	1.77	6.35	1.72	6.14	1.66	5.72	1.55
	51.8	49.64	7.44	1.9	7.02	1.79	6.6	1.69	6.35	1.63	6.14	1.58	5.72	1.48
	55.4	53.24	7.44	1.8	7.02	1.7	6.6	1.6	6.35	1.56	6.14	1.51	5.72	1.41
59	56.66	7.44	1.72	7.02	1.62	6.6	1.53	6.35	1.48	6.14	1.44	5.72	1.35	

**Note:**

1. [ ] is tested under our standard condition.
2. Avoid to run the unit when the temperature is below 5°F (-15°C).
3. The above table shows the average value of conditions may operate.
4. It is recommended to connect less than 130%.

**MDV-V140W/DVN1**  
**Cooling**

Combination (%) (Capacity index)	Outdoor temperature (°F DB)	Indoor temperature(°F DB/WB)													
		DB:69.4,WB:57.2		DB:73.9,WB:60.8		DB:78.4,WB:64.4		DB:80.6,WB:66.2		DB:82.7,WB:68		DB:87.3,WB:71.6		DB:89.6,WB:75.2	
		TC	PI	TC	PI	TC	PI	TC	PI	TC	PI	TC	PI	TC	PI
		kW	kW	kW	kW	kW	kW	kW	kW	kW	kW	kW	kW	kW	kW
130%	23	12.3	1.94	14.65	2.36	17	2.54	17.65	2.64	18.5	2.71	18.95	2.95	19.43	2.97
	28.4	12.3	1.94	14.65	2.41	17	2.54	17.65	2.65	18.5	2.71	18.95	2.99	19.43	3
	32	12.3	1.97	14.65	2.45	17	2.63	17.65	2.8	18.5	2.87	18.95	3.02	19.43	3.04
	35.6	12.3	2.01	14.65	2.46	17	2.72	17.65	2.96	18.5	2.9	18.95	3.05	19.43	3.08
	39.2	12.3	2.05	14.65	2.51	17	2.81	17.65	2.97	18.5	2.94	18.95	3.04	19.43	3.14
	42.8	12.3	2.09	14.65	2.56	17	2.92	17.65	2.99	18.29	3.03	18.72	3.04	19.21	3.17
	46.4	12.3	2.14	14.65	2.61	17	3.06	17.65	3.14	18.07	3.13	18.51	3.9	18.97	3.2
	50	12.3	2.19	14.65	2.67	17	3.17	17.65	3.25	17.85	4.04	18.3	4.06	18.75	3.29
	53.6	12.3	2.22	14.65	2.72	17	3.24	17.4	4.03	17.65	4.06	18.05	4.07	18.5	3.31
	57.2	12.3	2.27	14.65	2.77	16.95	4.05	17.2	4.06	17.4	4.08	17.85	4.09	18.3	3.38
	60.8	12.3	2.31	14.65	2.83	16.75	4.06	16.95	4.08	17.15	4.1	17.6	4.12	18.05	3.44
	64.4	12.3	2.35	14.65	2.89	16.5	3.39	16.7	3.41	16.95	3.42	17.4	3.46	17.85	3.49
	68	12.3	2.4	14.65	3.07	16.25	3.55	16.5	3.57	16.7	3.59	17.15	3.62	17.6	3.66
	69.8	12.3	2.47	14.65	3.18	16.15	3.64	16.4	3.65	16.6	3.67	17.05	3.71	17.5	3.74
	73.4	12.3	2.64	14.65	3.41	15.95	3.8	16.15	3.82	16.35	3.84	16.8	3.88	17.25	3.92
	77	12.3	2.82	14.65	3.65	15.7	3.97	15.9	3.99	16.15	4.01	16.6	4.05	17.05	4.09
	80.6	12.3	3.02	14.65	3.91	15.5	4.13	15.7	4.16	15.9	4.18	16.35	4.22	16.8	4.27
	84.2	12.3	3.22	14.65	4.18	15.25	4.3	15.45	4.33	15.7	4.35	16.15	4.4	16.6	4.44
	87.8	12.3	3.44	14.6	4.42	15	4.47	15.25	4.5	15.45	4.52	15.9	4.57	16.35	4.62
	91.4	12.3	3.66	14.35	4.59	14.8	4.64	15	4.66	15.25	4.69	15.7	4.74	16.1	4.79
95	12.3	3.9	14.1	4.75	14.55	4.81	14.8	4.84	15	4.86	15.45	4.92	15.9	4.97	
98.6	12.3	4.15	13.9	4.93	14.35	4.98	14.55	5.01	14.8	5.04	15.2	5.1	15.65	5.16	
102.2	12.3	4.42	13.65	4.98	14.1	5.15	14.35	5.18	14.55	5.21	15	5.27	15.45	5.33	
105.8	12.3	4.65	13.51	5.03	13.95	5.2	14.2	5.23	14.4	5.26	14.85	5.28	14.86	5.38	
109.4	12.3	4.77	13.41	5.05	13.88	5.21	14.13	5.25	14.25	5.27	14.58	5.29	14.68	5.39	
120%	23	11.35	1.87	13.5	2.27	15.7	2.68	16.8	2.92	17.6	3.05	18	3.14	18.4	3.23
	28.4	11.35	1.89	13.5	2.29	15.7	2.71	16.8	2.94	17.6	3.08	18	3.17	18.4	3.24
	32	11.35	1.91	13.5	2.31	15.7	2.74	16.8	2.95	17.6	3.11	18	3.19	18.4	3.25
	35.6	11.35	1.91	13.5	2.33	15.7	2.76	16.8	2.98	17.6	3.12	18	3.21	18.4	3.25
	39.2	11.35	1.93	13.5	2.36	15.7	2.8	16.8	3	17.6	3.16	18	3.22	18.4	3.26
	42.8	11.35	1.95	13.5	2.38	15.7	2.83	16.8	3.04	17.6	3.2	18	3.25	18.4	3.27
	46.4	11.35	1.97	13.5	2.4	15.7	2.87	16.8	3.07	17.6	3.23	18	3.26	18.4	3.29
	50	11.35	1.99	13.5	2.43	15.7	2.89	16.8	3.13	17.6	3.23	18	3.27	18.4	3.3
	53.6	11.35	2.03	13.5	2.48	15.7	2.95	16.8	3.19	17.35	3.25	17.75	3.25	18.15	3.32
	57.2	11.35	2.07	13.5	2.53	15.7	3.01	16.8	3.25	17.1	3.27	17.55	3.3	17.95	3.36
	60.8	11.35	2.11	13.5	2.58	15.7	3.07	16.7	4.1	16.9	3.31	17.3	3.35	17.7	3.41
	64.4	11.35	2.15	13.5	2.63	15.7	3.17	16.45	3.39	16.65	3.4	17.05	3.43	17.5	3.46
	68	11.35	2.19	13.5	2.73	15.7	3.41	16.25	3.55	16.45	3.56	16.85	3.6	17.25	3.63
	69.8	11.35	2.21	13.5	2.83	15.7	3.53	16.1	3.63	16.3	3.65	16.75	3.68	17.15	3.72
	73.4	11.35	2.36	13.5	3.03	15.7	3.78	15.9	3.79	16.1	3.81	16.5	3.85	16.9	3.88
	77	11.35	2.52	13.5	3.25	15.45	3.95	15.65	3.96	15.85	3.98	16.3	4.02	16.7	4.06
	80.6	11.35	2.7	13.5	3.47	15.25	4.11	15.45	4.13	15.65	4.15	16.05	4.19	16.45	4.23
	84.2	11.35	2.87	13.5	3.71	15	4.27	15.2	4.3	15.4	4.32	15.8	4.36	16.25	4.4
	87.8	11.35	3.07	13.5	3.95	14.75	4.45	15	4.47	15.2	4.49	15.6	4.54	16	4.58
	91.4	11.35	3.26	13.5	4.22	14.55	4.61	14.75	4.64	14.95	4.66	15.35	4.71	15.75	4.75
95	11.35	3.48	13.5	4.5	14.3	4.78	14.5	4.8	14.75	4.83	15.15	4.88	15.55	4.93	
98.6	11.35	3.7	13.5	4.79	14.1	4.95	14.3	4.98	14.5	5	14.9	5.05	15.3	5.11	
102.2	11.35	3.93	13.45	5.06	13.85	5.12	14.05	5.15	14.25	5.17	14.7	5.23	15.1	5.28	
105.8	11.35	4.04	13.34	5.1	13.74	5.15	13.94	5.18	14.14	5.21	14.59	5.25	14.67	5.32	
109.4	11.35	4.1	13.27	5.13	13.63	5.18	13.83	5.2	14.03	5.23	14.34	5.26	14.44	5.43	

MDV-V140W/DVN1

Cooling

Combination (%) (Capacity index)	Outdoor temperature (°F DB)	Indoor temperature(°F DB/WB)													
		DB:69.4,WB:57.2		DB:73.9,WB:60.8		DB:78.4,WB:64.4		DB:80.6,WB:66.2		DB:82.7,WB:68		DB:87.3,WB:71.6		DB:89.6,WB:75.2	
		TC	PI	TC	PI	TC	PI	TC	PI	TC	PI	TC	PI	TC	PI
		kW	kW	kW	kW	kW	kW	kW	kW	kW	kW	kW	kW	kW	kW
110%	23	10.4	1.63	12.4	2.03	14.4	2.43	15.4	2.61	16.4	2.8	17.65	2.91	18.05	3
	28.4	10.4	1.67	12.4	2.06	14.4	2.45	15.4	2.63	16.4	2.83	17.65	2.94	18.05	3.02
	32	10.4	1.68	12.4	2.07	14.4	2.47	15.4	2.65	16.4	2.86	17.65	2.97	18.05	3.05
	35.6	10.4	1.72	12.4	2.09	14.4	2.51	15.4	2.68	16.4	2.89	17.65	3.01	18.05	3.09
	39.2	10.4	1.75	12.4	2.12	14.4	2.53	15.4	2.71	16.4	2.93	17.65	3.05	18.05	3.12
	42.8	10.4	1.77	12.4	2.14	14.4	2.55	15.4	2.75	16.4	2.96	17.65	3.09	18.05	3.17
	46.4	10.4	1.79	12.4	2.17	14.4	2.58	15.4	2.78	16.4	3	17.65	3.11	18.05	3.2
	50	10.4	1.81	12.4	2.2	14.4	2.62	15.4	2.83	16.4	3.05	17.65	3.13	18.05	3.23
	53.6	10.4	1.85	12.4	2.25	14.4	2.67	15.4	2.89	16.4	3.1	17.45	3.17	17.8	3.27
	57.2	10.4	1.88	12.4	2.29	14.4	2.72	15.4	2.94	16.4	3.16	17.2	3.2	17.6	3.3
	60.8	10.4	1.91	12.4	2.33	14.4	2.77	15.4	3	16.4	3.23	17	3.24	17.35	3.33
	64.4	10.4	1.95	12.4	2.38	14.4	2.83	15.4	3.08	16.4	3.38	16.75	3.4	17.15	3.44
	68	10.4	1.99	12.4	2.43	14.4	3	15.4	3.31	16.15	3.55	16.55	3.57	16.9	3.6
	69.8	10.4	2.01	12.4	2.5	14.4	3.1	15.4	3.43	16.05	3.63	16.4	3.65	16.8	3.69
	73.4	10.4	2.1	12.4	2.68	14.4	3.33	15.4	3.68	15.8	3.79	16.2	3.83	16.55	3.86
	77	10.4	2.24	12.4	2.86	14.4	3.56	15.4	3.94	15.6	3.95	15.95	3.99	16.35	4.02
	80.6	10.4	2.39	12.4	3.06	14.4	3.81	15.15	4.11	15.35	4.12	15.75	4.16	16.1	4.2
	84.2	10.4	2.55	12.4	3.26	14.4	4.07	14.95	4.27	15.15	4.29	15.5	4.33	15.9	4.37
	87.8	10.4	2.71	12.4	3.48	14.4	4.34	14.7	4.44	14.9	4.46	15.3	4.5	15.65	4.54
	91.4	10.4	2.89	12.4	3.71	14.3	4.58	14.5	4.61	14.7	4.63	15.05	4.67	15.45	4.71
95	10.4	3.07	12.4	3.95	14.05	4.75	14.25	4.77	14.45	4.8	14.8	4.84	15.2	4.89	
98.6	10.4	3.27	12.4	4.21	13.85	4.92	14.05	4.94	14.2	4.96	14.6	5.02	14.95	5.06	
102.2	10.4	3.48	12.4	4.48	13.6	5.09	13.8	5.11	14	5.14	14.35	5.19	14.75	5.24	
105.8	10.4	3.51	12.4	4.52	13.49	5.12	13.69	5.15	13.89	5.17	14.17	5.22	14.31	5.27	
109.4	10.4	3.55	12.4	4.58	13.39	5.16	13.59	5.18	13.79	5.21	14.04	5.24	14.09	5.38	
100%	23	9.45	1.49	11.25	1.79	13.1	2.13	14	2.28	14.9	2.48	16.75	2.83	17.7	2.95
	28.4	9.45	1.51	11.25	1.82	13.1	2.16	14	2.33	14.9	2.51	16.75	2.86	17.7	2.97
	32	9.45	1.52	11.25	1.83	13.1	2.18	14	2.36	14.9	2.54	16.75	2.91	17.7	3
	35.6	9.45	1.55	11.25	1.86	13.1	2.2	14	2.39	14.9	2.56	16.75	2.95	17.7	3.05
	39.2	9.45	1.56	11.25	1.88	13.1	2.24	14	2.42	14.9	2.6	16.75	2.98	17.7	3.08
	42.8	9.45	1.59	11.25	1.91	13.1	2.27	14	2.46	14.9	2.64	16.75	3.02	17.7	3.13
	46.4	9.45	1.62	11.25	1.94	13.1	2.31	14	2.49	14.9	2.68	16.75	3.07	17.7	3.18
	50	9.45	1.64	11.25	1.98	13.1	2.34	14	2.54	14.9	2.73	16.75	3.12	17.7	3.23
	53.6	9.45	1.66	11.25	2.02	13.1	2.39	14	2.58	14.9	2.78	16.75	3.17	17.45	3.25
	57.2	9.45	1.69	11.25	2.06	13.1	2.43	14	2.63	14.9	2.83	16.75	3.24	17.25	3.29
	60.8	9.45	1.72	11.25	2.1	13.1	2.49	14	2.68	14.9	2.89	16.65	3.28	17	3.33
	64.4	9.45	1.76	11.25	2.13	13.1	2.53	14	2.73	14.9	2.94	16.45	3.39	16.8	3.41
	68	9.45	1.79	11.25	2.18	13.1	2.61	14	2.87	14.9	3.16	16.2	3.55	16.55	3.58
	69.8	9.45	1.81	11.25	2.2	13.1	2.7	14	2.98	14.9	3.26	16.1	3.63	16.45	3.66
	73.4	9.45	1.85	11.25	2.34	13.1	2.89	14	3.19	14.9	3.5	15.9	3.79	16.2	3.83
	77	9.45	1.97	11.25	2.5	13.1	3.1	14	3.42	14.9	3.75	15.65	3.96	16	3.99
	80.6	9.45	2.11	11.25	2.67	13.1	3.31	14	3.65	14.9	4.01	15.4	4.13	15.75	4.17
	84.2	9.45	2.24	11.25	2.85	13.1	3.53	14	3.9	14.85	4.26	15.2	4.3	15.55	4.33
	87.8	9.45	2.39	11.25	3.04	13.1	3.77	14	4.17	14.65	4.43	14.95	4.47	15.3	4.5
	91.4	9.45	2.54	11.25	3.24	13.1	4.02	14	4.45	14.4	4.59	14.75	4.63	15.1	4.68
95	9.45	2.7	11.25	3.44	13.1	4.29	14	4.74	14.15	4.76	14.5	4.8	14.85	4.84	
98.6	9.45	2.87	11.25	3.67	13.1	4.57	13.75	4.91	13.95	4.93	14.3	4.98	14.6	5.01	
102.2	9.45	3.05	11.25	3.9	13.1	4.86	13.55	5.07	13.7	5.1	14.05	5.14	14.4	5.19	
105.8	9.45	3.19	11.25	4.04	13.1	5.04	13.34	5.11	13.59	5.18	13.81	5.26	14.19	5.3	
109.4	9.45	3.33	11.25	4.18	13.1	5.13	13.13	5.17	13.5	5.23	13.89	5.3	13.94	5.36	

**MDV-V140W/DVN1**

**Cooling**

Combination (%) (Capacity index)	Outdoor temperature (°F DB)	Indoor temperature(°F DB/WB)													
		DB:69.4,WB:57.2		DB:73.9,WB:60.8		DB:78.4,WB:64.4		DB:80.6,WB:66.2		DB:82.7,WB:68		DB:87.3,WB:71.6		DB:89.6,WB:75.2	
		TC	PI	TC	PI	TC	PI	TC	PI	TC	PI	TC	PI	TC	PI
		kW	kW	kW	kW	kW	kW	kW	kW	kW	kW	kW	kW	kW	kW
90%	23	8.5	1.32	10.15	1.58	11.8	1.86	12.6	2.03	13.4	2.16	15.05	2.49	16.7	2.85
	28.4	8.5	1.33	10.15	1.6	11.8	1.89	12.6	2.06	13.4	2.19	15.05	2.51	16.7	2.88
	32	8.5	1.35	10.15	1.62	11.8	1.92	12.6	2.09	13.4	2.22	15.05	2.54	16.7	2.9
	35.6	8.5	1.37	10.15	1.64	11.8	1.94	12.6	2.12	13.4	2.25	15.05	2.59	16.7	2.94
	39.2	8.5	1.39	10.15	1.66	11.8	1.97	12.6	2.15	13.4	2.28	15.05	2.63	16.7	2.98
	42.8	8.5	1.41	10.15	1.69	11.8	2	12.6	2.19	13.4	2.32	15.05	2.67	16.7	3.03
	46.4	8.5	1.44	10.15	1.73	11.8	2.05	12.6	2.22	13.4	2.36	15.05	2.72	16.7	3.06
	50	8.5	1.46	10.15	1.76	11.8	2.08	12.6	2.25	13.4	2.41	15.05	2.76	16.7	3.11
	53.6	8.5	1.49	10.15	1.79	11.8	2.12	12.6	2.29	13.4	2.46	15.05	2.81	16.7	3.17
	57.2	8.5	1.51	10.15	1.83	11.8	2.16	12.6	2.33	13.4	2.5	15.05	2.86	16.7	3.23
	60.8	8.5	1.54	10.15	1.86	11.8	2.2	12.6	2.38	13.4	2.56	15.05	2.92	16.65	3.28
	64.4	8.5	1.56	10.15	1.9	11.8	2.24	12.6	2.42	13.4	2.61	15.05	2.98	16.45	3.39
	68	8.5	1.6	10.15	1.94	11.8	2.29	12.6	2.47	13.4	2.7	15.05	3.2	16.2	3.55
	69.8	8.5	1.61	10.15	1.95	11.8	2.33	12.6	2.56	13.4	2.8	15.05	3.32	16.1	3.63
	73.4	8.5	1.64	10.15	2.03	11.8	2.49	12.6	2.74	13.4	3	15.05	3.56	15.85	3.79
	77	8.5	1.73	10.15	2.17	11.8	2.66	12.6	2.93	13.4	3.21	15.05	3.81	15.65	3.96
	80.6	8.5	1.84	10.15	2.31	11.8	2.84	12.6	3.13	13.4	3.43	15.05	4.08	15.4	4.13
	84.2	8.5	1.96	10.15	2.47	11.8	3.03	12.6	3.34	13.4	3.67	14.9	4.26	15.2	4.29
	87.8	8.5	2.08	10.15	2.63	11.8	3.23	12.6	3.56	13.4	3.91	14.65	4.43	14.95	4.46
	91.4	8.5	2.21	10.15	2.79	11.8	3.45	12.6	3.8	13.4	4.17	14.45	4.6	14.75	4.63
95	8.5	2.35	10.15	2.97	11.8	3.67	12.6	4.05	13.4	4.45	14.2	4.77	14.5	4.8	
98.6	8.5	2.49	10.15	3.16	11.8	3.91	12.6	4.31	13.4	4.74	13.95	4.93	14.3	4.97	
102.2	8.5	2.64	10.15	3.36	11.8	4.16	12.6	4.59	13.4	5.05	13.75	5.1	14.05	5.14	
105.8	8.5	2.74	10.15	3.51	11.8	4.31	12.6	4.71	13.4	5.08	13.65	5.23	13.96	5.26	
109.4	8.5	2.87	10.15	3.66	11.8	4.46	12.6	4.84	13.4	5.19	13.58	5.3	13.84	5.35	
80%	23	7.55	1.16	9	1.37	10.45	1.62	11.2	1.73	11.95	1.86	13.4	2.15	14.85	2.45
	28.4	7.55	1.18	9	1.39	10.45	1.64	11.2	1.75	11.95	1.88	13.4	2.17	14.85	2.48
	32	7.55	1.2	9	1.41	10.45	1.66	11.2	1.77	11.95	1.91	13.4	2.2	14.85	2.51
	35.6	7.55	1.22	9	1.43	10.45	1.68	11.2	1.81	11.95	1.94	13.4	2.24	14.85	2.56
	39.2	7.55	1.24	9	1.45	10.45	1.71	11.2	1.85	11.95	1.98	13.4	2.29	14.85	2.59
	42.8	7.55	1.26	9	1.48	10.45	1.74	11.2	1.89	11.95	2.02	13.4	2.32	14.85	2.64
	46.4	7.55	1.29	9	1.52	10.45	1.78	11.2	1.92	11.95	2.06	13.4	2.35	14.85	2.69
	50	7.55	1.3	9	1.55	10.45	1.83	11.2	1.97	11.95	2.11	13.4	2.41	14.85	2.72
	53.6	7.55	1.32	9	1.58	10.45	1.86	11.2	2.01	11.95	2.15	13.4	2.45	14.85	2.77
	57.2	7.55	1.34	9	1.61	10.45	1.89	11.2	2.04	11.95	2.19	13.4	2.5	14.85	2.82
	60.8	7.55	1.36	9	1.64	10.45	1.93	11.2	2.08	11.95	2.23	13.4	2.55	14.85	2.87
	64.4	7.55	1.39	9	1.67	10.45	1.97	11.2	2.12	11.95	2.27	13.4	2.6	14.85	2.93
	68	7.55	1.41	9	1.7	10.45	2.01	11.2	2.16	11.95	2.32	13.4	2.7	14.85	3.13
	69.8	7.55	1.42	9	1.71	10.45	2.02	11.2	2.18	11.95	2.37	13.4	2.79	14.85	3.25
	73.4	7.55	1.45	9	1.75	10.45	2.12	11.2	2.33	11.95	2.54	13.4	2.99	14.85	3.48
	77	7.55	1.49	9	1.86	10.45	2.27	11.2	2.49	11.95	2.71	13.4	3.2	14.85	3.72
	80.6	7.55	1.59	9	1.98	10.45	2.41	11.2	2.65	11.95	2.89	13.4	3.42	14.85	3.99
	84.2	7.55	1.69	9	2.11	10.45	2.57	11.2	2.82	11.95	3.09	13.4	3.65	14.85	4.26
	87.8	7.55	1.8	9	2.24	10.45	2.74	11.2	3.01	11.95	3.3	13.4	3.9	14.6	4.43
	91.4	7.55	1.91	9	2.38	10.45	2.92	11.2	3.21	11.95	3.51	13.4	4.15	14.4	4.59
95	7.55	2.02	9	2.54	10.45	3.1	11.2	3.41	11.95	3.74	13.4	4.43	14.15	4.76	
98.6	7.55	2.15	9	2.69	10.45	3.3	11.2	3.63	11.95	3.98	13.4	4.72	13.95	4.93	
102.2	7.55	2.27	9	2.87	10.45	3.51	11.2	3.87	11.95	4.24	13.4	5.03	13.7	5.1	
105.8	7.55	2.33	9	2.89	10.45	3.56	11.2	3.97	11.95	4.31	13.4	5.16	13.62	5.19	
109.4	7.55	2.39	9	2.92	10.45	3.62	11.2	4.04	11.95	4.37	13.4	5.22	13.53	5.24	

**MDV-V140W/DVN1**  
**Cooling**

Combination (%) (Capacity index)	Outdoor temperature (°F DB)	Indoor temperature(°F DB/WB)													
		DB:69.4,WB:57.2		DB:73.9,WB:60.8		DB:78.4,WB:64.4		DB:80.6,WB:66.2		DB:82.7,WB:68		DB:87.3,WB:71.6		DB:89.6,WB:75.2	
		TC	PI	TC	PI	TC	PI	TC	PI	TC	PI	TC	PI	TC	PI
		kW	kW	kW	kW	kW	kW	kW	kW	kW	kW	kW	kW	kW	kW
70%	23	6.6	1.04	7.9	1.21	9.15	1.38	9.8	1.47	10.45	1.57	11.7	1.8	13	2.07
	28.4	6.6	1.04	7.9	1.22	9.15	1.38	9.8	1.5	10.45	1.6	11.7	1.83	13	2.1
	32	6.6	1.05	7.9	1.24	9.15	1.41	9.8	1.53	10.45	1.63	11.7	1.87	13	2.13
	35.6	6.6	1.06	7.9	1.24	9.15	1.44	9.8	1.56	10.45	1.66	11.7	1.91	13	2.16
	39.2	6.6	1.07	7.9	1.27	9.15	1.47	9.8	1.59	10.45	1.7	11.7	1.94	13	2.21
	42.8	6.6	1.09	7.9	1.3	9.15	1.5	9.8	1.64	10.45	1.74	11.7	1.97	13	2.25
	46.4	6.6	1.11	7.9	1.33	9.15	1.54	9.8	1.66	10.45	1.77	11.7	2.03	13	2.3
	50	6.6	1.13	7.9	1.35	9.15	1.58	9.8	1.7	10.45	1.82	11.7	2.07	13	2.33
	53.6	6.6	1.16	7.9	1.37	9.15	1.61	9.8	1.73	10.45	1.85	11.7	2.11	13	2.37
	57.2	6.6	1.18	7.9	1.4	9.15	1.64	9.8	1.76	10.45	1.88	11.7	2.15	13	2.41
	60.8	6.6	1.19	7.9	1.42	9.15	1.67	9.8	1.8	10.45	1.92	11.7	2.18	13	2.46
	64.4	6.6	1.21	7.9	1.45	9.15	1.7	9.8	1.83	10.45	1.95	11.7	2.23	13	2.51
	68	6.6	1.23	7.9	1.48	9.15	1.73	9.8	1.86	10.45	1.99	11.7	2.27	13	2.58
	69.8	6.6	1.25	7.9	1.49	9.15	1.74	9.8	1.88	10.45	2.01	11.7	2.31	13	2.67
	73.4	6.6	1.26	7.9	1.51	9.15	1.78	9.8	1.94	10.45	2.11	11.7	2.47	13	2.86
	77	6.6	1.29	7.9	1.58	9.15	1.9	9.8	2.08	10.45	2.25	11.7	2.64	13	3.06
	80.6	6.6	1.37	7.9	1.68	9.15	2.03	9.8	2.21	10.45	2.41	11.7	2.82	13	3.27
	84.2	6.6	1.45	7.9	1.78	9.15	2.15	9.8	2.36	10.45	2.56	11.7	3.01	13	3.49
	87.8	6.6	1.53	7.9	1.89	9.15	2.29	9.8	2.5	10.45	2.73	11.7	3.21	13	3.72
	91.4	6.6	1.63	7.9	2.01	9.15	2.44	9.8	2.66	10.45	2.91	11.7	3.42	13	3.97
95	6.6	1.72	7.9	2.13	9.15	2.59	9.8	2.84	10.45	3.09	11.7	3.64	13	4.24	
98.6	6.6	1.82	7.9	2.26	9.15	2.75	9.8	3.01	10.45	3.29	11.7	3.88	13	4.51	
102.2	6.6	1.93	7.9	2.4	9.15	2.92	9.8	3.2	10.45	3.49	11.7	4.12	13	4.8	
105.8	6.6	2.01	7.9	2.48	9.15	3	9.8	3.31	10.45	3.6	11.7	4.29	13	5.02	
109.4	6.6	2.18	7.9	2.65	9.15	3.13	9.8	3.48	10.45	3.71	11.7	4.45	13	5.17	
60%	23	5.65	0.88	6.75	1.02	7.85	1.19	8.4	1.27	8.95	1.37	10.05	1.54	11.15	1.77
	28.4	5.65	0.89	6.75	1.04	7.85	1.22	8.4	1.29	8.95	1.39	10.05	1.57	11.15	1.78
	32	5.65	0.9	6.75	1.05	7.85	1.23	8.4	1.31	8.95	1.41	10.05	1.59	11.15	1.8
	35.6	5.65	0.92	6.75	1.08	7.85	1.25	8.4	1.33	8.95	1.43	10.05	1.62	11.15	1.83
	39.2	5.65	0.94	6.75	1.1	7.85	1.28	8.4	1.35	8.95	1.45	10.05	1.65	11.15	1.85
	42.8	5.65	0.95	6.75	1.12	7.85	1.3	8.4	1.38	8.95	1.48	10.05	1.68	11.15	1.9
	46.4	5.65	0.97	6.75	1.14	7.85	1.33	8.4	1.4	8.95	1.51	10.05	1.71	11.15	1.93
	50	5.65	0.99	6.75	1.16	7.85	1.35	8.4	1.44	8.95	1.54	10.05	1.74	11.15	1.95
	53.6	5.65	1.01	6.75	1.18	7.85	1.37	8.4	1.47	8.95	1.56	10.05	1.78	11.15	1.99
	57.2	5.65	1.02	6.75	1.2	7.85	1.39	8.4	1.49	8.95	1.6	10.05	1.81	11.15	2.02
	60.8	5.65	1.03	6.75	1.22	7.85	1.42	8.4	1.52	8.95	1.62	10.05	1.84	11.15	2.06
	64.4	5.65	1.05	6.75	1.24	7.85	1.44	8.4	1.55	8.95	1.65	10.05	1.87	11.15	2.1
	68	5.65	1.07	6.75	1.26	7.85	1.47	8.4	1.58	8.95	1.69	10.05	1.91	11.15	2.15
	69.8	5.65	1.08	6.75	1.27	7.85	1.48	8.4	1.59	8.95	1.7	10.05	1.93	11.15	2.17
	73.4	5.65	1.09	6.75	1.3	7.85	1.51	8.4	1.62	8.95	1.73	10.05	2.01	11.15	2.31
	77	5.65	1.11	6.75	1.32	7.85	1.56	8.4	1.7	8.95	1.84	10.05	2.14	11.15	2.46
	80.6	5.65	1.16	6.75	1.4	7.85	1.67	8.4	1.81	8.95	1.96	10.05	2.28	11.15	2.63
	84.2	5.65	1.22	6.75	1.48	7.85	1.78	8.4	1.93	8.95	2.09	10.05	2.43	11.15	2.8
	87.8	5.65	1.3	6.75	1.57	7.85	1.88	8.4	2.05	8.95	2.22	10.05	2.59	11.15	2.98
	91.4	5.65	1.37	6.75	1.67	7.85	2	8.4	2.18	8.95	2.36	10.05	2.75	11.15	3.18
95	5.65	1.45	6.75	1.77	7.85	2.12	8.4	2.31	8.95	2.51	10.05	2.93	11.15	3.39	
98.6	5.65	1.53	6.75	1.87	7.85	2.25	8.4	2.45	8.95	2.66	10.05	3.12	11.15	3.6	
102.2	5.65	1.62	6.75	1.98	7.85	2.38	8.4	2.6	8.95	2.83	10.05	3.31	11.15	3.83	
105.8	5.65	1.67	6.75	2.07	7.85	2.47	8.4	2.7	8.95	2.93	10.05	3.46	11.15	4.01	
109.4	5.65	1.72	6.75	2.15	7.85	2.56	8.4	2.78	8.95	3.04	10.05	3.61	11.15	4.18	



**MDV-V140W/DVN1**

**Cooling**

Combination (%) (Capacity index)	Outdoor temperature (°F DB)	Indoor temperature(°F DB/WB)													
		DB:69.4,WB:57.2		DB:73.9,WB:60.8		DB:78.4,WB:64.4		DB:80.6,WB:66.2		DB:82.7,WB:68		DB:87.3,WB:71.6		DB:89.6,WB:75.2	
		TC	PI	TC	PI	TC	PI	TC	PI	TC	PI	TC	PI	TC	PI
		kW	kW	kW	kW	kW	kW	kW	kW	kW	kW	kW	kW	kW	kW
50%	23	4.73	0.77	5.65	0.89	6.55	1.02	7	1.07	7.45	1.13	8.35	1.28	9.3	1.38
	28.4	4.73	0.77	5.65	0.91	6.55	1.03	7	1.08	7.45	1.15	8.35	1.3	9.3	1.4
	32	4.73	0.79	5.65	0.92	6.55	1.05	7	1.1	7.45	1.16	8.35	1.32	9.3	1.42
	35.6	4.73	0.8	5.65	0.93	6.55	1.07	7	1.11	7.45	1.18	8.35	1.32	9.3	1.45
	39.2	4.73	0.8	5.65	0.95	6.55	1.08	7	1.13	7.45	1.2	8.35	1.36	9.3	1.49
	42.8	4.73	0.82	5.65	0.96	6.55	1.09	7	1.15	7.45	1.23	8.35	1.38	9.3	1.53
	46.4	4.73	0.84	5.65	0.98	6.55	1.11	7	1.18	7.45	1.24	8.35	1.4	9.3	1.58
	50	4.73	0.86	5.65	0.99	6.55	1.13	7	1.2	7.45	1.28	8.35	1.44	9.3	1.6
	53.6	4.73	0.86	5.65	1	6.55	1.15	7	1.22	7.45	1.3	8.35	1.46	9.3	1.63
	57.2	4.73	0.88	5.65	1.02	6.55	1.16	7	1.25	7.45	1.32	8.35	1.49	9.3	1.66
	60.8	4.73	0.89	5.65	1.03	6.55	1.18	7	1.26	7.45	1.34	8.35	1.51	9.3	1.69
	64.4	4.73	0.9	5.65	1.05	6.55	1.2	7	1.28	7.45	1.37	8.35	1.54	9.3	1.72
	68	4.73	0.91	5.65	1.06	6.55	1.22	7	1.3	7.45	1.39	8.35	1.56	9.3	1.75
	69.8	4.73	0.92	5.65	1.07	6.55	1.23	7	1.32	7.45	1.41	8.35	1.58	9.3	1.77
	73.4	4.73	0.93	5.65	1.09	6.55	1.25	7	1.34	7.45	1.43	8.35	1.61	9.3	1.81
	77	4.73	0.95	5.65	1.11	6.55	1.28	7	1.37	7.45	1.48	8.35	1.69	9.3	1.93
	80.6	4.73	0.96	5.65	1.15	6.55	1.35	7	1.46	7.45	1.56	8.35	1.8	9.3	2.06
	84.2	4.73	1.02	5.65	1.21	6.55	1.43	7	1.55	7.45	1.67	8.35	1.92	9.3	2.19
	87.8	4.73	1.07	5.65	1.28	6.55	1.51	7	1.64	7.45	1.77	8.35	2.04	9.3	2.33
	91.4	4.73	1.14	5.65	1.36	6.55	1.61	7	1.74	7.45	1.88	8.35	2.17	9.3	2.48
95	4.73	1.2	5.65	1.44	6.55	1.7	7	1.84	7.45	1.99	8.35	2.3	9.3	2.63	
98.6	4.73	1.26	5.65	1.52	6.55	1.8	7	1.95	7.45	2.11	8.35	2.44	9.3	2.8	
102.2	4.73	1.33	5.65	1.6	6.55	1.9	7	2.06	7.45	2.24	8.35	2.59	9.3	2.97	
105.8	4.73	1.39	5.65	1.67	6.55	1.97	7	2.16	7.45	2.33	8.35	2.72	9.3	3.11	
109.4	4.73	1.48	5.65	1.79	6.55	2.04	7	2.26	7.45	2.39	8.35	2.86	9.3	3.25	

**Note:**

1. \_\_\_\_\_ is tested under our standard condition.
2. Avoid to run the unit when the temperature is above 109.4°F (43°C).
3. The above table shows the average value of conditions may operate.
4. It is recommended to connect less than 130%.

**MDV-V140W/DVN1**  
**Heating**

Combination (%) (Capacity index)	Outdoor Air temperature(°F)		Indoor temperature(°F WB)											
			60.8		64.4		68		69.8		71.6		75.2	
	°F DB	°F WB	TC	PI	TC	PI	TC	PI	TC	PI	TC	PI	TC	PI
			kW	kW	kW	kW	kW	kW	kW	kW	kW	kW	kW	kW
130%	7.34	5	10.95	3.92	10.9	4.15	10.85	4.37	10.85	4.48	10.8	4.6	10.8	4.82
	10.76	8.6	11.39	4.1	11.39	4.32	11.34	4.53	11.29	4.64	11.29	4.75	11.24	4.96
	14.36	12.2	11.93	4.28	11.88	4.48	11.83	4.69	11.83	4.79	11.83	4.9	11.78	5.1
	14.9	14	12.22	4.37	12.17	4.57	12.12	4.77	12.12	4.87	12.08	4.97	12.08	5.17
	16.7	15.62	12.47	4.44	12.42	4.64	12.42	4.84	12.37	4.93	12.37	5.03	12.32	5.23
	19.4	18.32	12.91	4.57	12.91	4.77	12.86	4.95	12.86	5.05	12.81	5.14	12.76	5.33
	23	21.92	13.59	4.75	13.54	4.93	13.49	5.11	13.49	5.2	13.44	5.28	13.44	5.46
	26.6	25.34	14.23	4.9	14.18	5.08	14.18	5.24	14.13	5.33	14.13	5.42	14.08	5.58
	32	30.74	15.35	5.14	15.35	5.3	15.3	5.46	15.3	5.51	15.25	5.62	15.25	5.77
	37.4	35.96	16.57	5.35	16.52	5.5	16.48	5.65	16.48	5.72	16.48	5.8	16.43	5.94
	41	39.38	17.4	5.49	17.35	5.63	17.35	5.77	17.31	5.84	17.31	5.91	17.26	6.04
	44.6	42.8	18.28	5.62	18.24	5.75	18.24	5.88	18.19	5.95	18.19	6.01	17.45	5.77
	48.2	46.22	19.21	5.73	19.16	5.86	19.16	5.98	19.12	6.05	18.72	5.92	17.45	5.42
	51.8	49.64	20.19	5.85	20.14	5.96	20.04	6.04	19.36	5.8	18.72	5.57	17.45	5.11
	55.4	53.24	21.27	5.96	21.22	6.07	20.04	5.66	19.36	5.44	18.72	5.22	17.45	4.79
59	56.66	22.29	6.06	21.32	5.75	20.04	5.33	19.36	5.13	18.72	4.92	17.45	4.52	
120%	7.34	5	10.9	4.23	10.85	4.43	10.81	4.64	10.81	4.75	10.81	4.85	10.76	5.06
	10.76	8.6	11.34	4.39	11.34	4.59	11.29	4.79	11.29	4.89	11.25	4.99	11.25	5.19
	14.36	12.2	11.88	4.55	11.83	4.74	11.83	4.93	11.78	5.03	11.78	5.12	11.73	5.31
	14.9	14	12.17	4.64	12.13	4.83	12.08	5	12.08	5.1	12.08	5.19	12.03	5.38
	16.7	15.62	12.42	4.71	12.37	4.89	12.37	5.07	12.32	5.16	12.32	5.26	12.27	5.44
	19.4	18.32	12.86	4.83	12.86	5	12.81	5.18	12.81	5.27	12.76	5.35	12.76	5.53
	23	21.92	13.54	4.99	13.49	5.15	13.44	5.32	13.44	5.4	13.44	5.49	13.4	5.65
	26.6	25.34	14.18	5.13	14.18	5.3	14.13	5.45	14.13	5.53	14.08	5.61	14.08	5.77
	32	30.74	15.3	5.35	15.3	5.5	15.25	5.64	15.25	5.72	15.2	5.79	15.2	5.94
	37.4	35.96	16.53	5.55	16.48	5.69	16.48	5.82	16.43	5.89	16.43	5.96	16.08	5.93
	41	39.38	17.36	5.67	17.31	5.8	17.31	5.93	17.26	6	17.26	6.06	16.08	5.57
	44.6	42.8	18.24	5.79	18.24	5.91	18.19	6.04	17.89	5.95	17.31	5.71	16.08	5.24
	48.2	46.22	19.17	5.91	19.12	6.02	18.48	5.82	17.89	5.59	17.31	5.37	16.08	4.93
	51.8	49.64	20.14	6.01	19.65	5.91	18.48	5.48	17.89	5.26	17.31	5.05	16.08	4.64
	55.4	53.24	20.88	5.95	19.65	5.54	18.48	5.13	17.89	4.94	17.31	4.75	16.08	4.37
59	56.66	20.88	5.6	19.65	5.22	18.48	4.84	17.89	4.66	17.31	4.48	16.08	4.12	
110%	7.34	5	10.85	4.53	10.81	4.72	10.76	4.91	10.76	5.01	10.76	5.1	10.71	5.29
	10.76	8.6	11.29	4.68	11.29	4.86	11.24	5.04	11.24	5.13	11.19	5.22	11.19	5.41
	14.36	12.2	11.83	4.83	11.78	5.01	11.78	5.18	11.73	5.27	11.73	5.35	11.73	5.53
	14.9	14	12.12	4.91	12.08	5.08	12.03	5.25	12.03	5.33	12.03	5.42	11.98	5.59
	16.7	15.62	12.37	4.97	12.32	5.14	12.32	5.31	12.27	5.39	12.27	5.48	12.27	4.99
	19.4	18.32	12.81	5.09	12.81	5.24	12.76	5.4	12.76	5.49	12.76	5.57	12.71	5.73
	23	21.92	13.49	5.23	13.44	5.39	13.4	5.53	13.4	5.61	13.4	5.69	13.35	5.84
	26.6	25.34	14.13	5.37	14.13	5.51	14.08	5.66	14.08	5.73	14.03	5.8	14.03	5.95
	32	30.74	15.25	5.57	15.25	5.7	15.21	5.84	15.21	5.9	15.21	5.97	14.76	5.86
	37.4	35.96	16.48	5.75	16.43	5.88	16.43	6	16.38	6.06	15.84	5.81	14.76	5.33
	41	39.38	17.31	5.86	17.31	5.98	16.96	5.93	16.38	5.69	15.84	5.46	14.76	5.01
	44.6	42.8	18.19	5.97	18.04	6.01	16.96	5.57	16.38	5.35	15.84	5.13	14.76	4.72
	48.2	46.22	19.12	6.07	18.04	5.65	16.96	5.24	16.38	5.03	15.84	4.83	14.76	4.44
	51.8	49.64	19.12	5.71	18.04	5.31	16.96	4.93	16.38	4.74	15.84	4.55	14.76	4.19
	55.4	53.24	19.12	5.35	18.04	4.99	16.96	4.63	16.38	4.46	15.84	4.28	14.76	3.95
59	56.66	19.12	4.75	18.04	4.7	16.96	4.37	16.38	4.21	15.84	4.05	14.76	3.74	

**MDV-V140W/DVN1**

**Heating**

Combination (%) (Capacity index)	Outdoor Air temperature(°F)		Indoor temperature(°F WB)											
			60.8		64.4		68		69.8		71.6		75.2	
	°F DB	°F WB	TC	PI	TC	PI	TC	PI	TC	PI	TC	PI	TC	PI
			kW	kW	kW	kW	kW	kW	kW	kW	kW	kW	kW	kW
100%	7.34	5	10.8	4.83	10.76	5.01	10.71	5.18	10.71	5.27	10.71	5.35	10.66	5.53
	10.76	8.6	11.25	4.97	11.25	5.13	11.2	5.3	11.2	5.39	11.2	5.47	11.15	5.64
	14.36	12.2	11.78	5.11	11.73	5.27	11.73	5.42	11.73	5.51	11.68	5.58	11.68	5.74
	14.9	14	12.08	5.18	12.03	5.33	12.03	5.49	11.98	5.57	11.98	5.64	11.93	5.8
	16.7	15.62	12.32	5.24	12.27	5.39	12.27	5.54	12.27	5.62	12.22	5.69	12.22	5.84
	19.4	18.32	12.76	5.34	12.76	5.49	12.71	5.63	12.71	5.71	12.71	5.78	12.66	5.93
	23	21.92	13.44	5.48	13.39	5.61	13.39	5.75	13.35	5.82	13.35	5.89	13.3	6.03
	26.6	25.34	14.08	5.6	14.08	5.08	14.03	5.86	14.03	5.93	14.03	5.99	13.44	5.74
	32	30.74	15.2	5.78	15.2	5.9	15.16	6.02	14.91	5.93	14.42	5.68	13.44	5.21
	37.4	35.96	16.43	5.95	16.38	6.06	15.4	5.6	14.91	5.39	14.42	5.17	13.44	4.75
	41	39.38	17.26	6.06	16.38	5.69	15.4	5.27	14.91	5.07	14.42	4.87	13.44	4.48
	44.6	42.8	17.36	5.75	16.38	5.35	15.4	4.96	14.91	4.77	14.42	4.59	13.44	4.22
	48.2	46.22	17.36	5.4	16.38	5.03	15.4	4.67	14.91	4.44	14.42	4.32	13.44	3.98
	51.8	49.64	17.36	5.08	16.38	4.74	15.4	4.41	14.91	4.24	14.42	4.08	13.44	3.76
	55.4	53.24	17.36	4.77	16.38	4.46	15.4	4.15	14.91	3.99	14.42	3.85	13.44	3.55
59	56.66	17.36	4.5	16.38	4.21	15.4	3.92	14.91	3.77	14.42	3.63	13.44	3.36	
90%	7.34	5	10.74	5.14	10.69	5.29	10.69	5.45	10.64	5.53	10.64	5.6	10.64	5.76
	10.76	8.6	11.18	5.26	11.18	5.41	11.13	5.56	11.13	5.64	11.13	5.71	11.08	5.86
	14.36	12.2	11.71	5.38	11.71	5.53	11.66	5.67	11.66	5.74	11.66	5.82	11.61	5.96
	14.9	14	12.01	5.45	11.96	5.59	11.96	5.73	11.91	5.8	11.91	5.87	11.91	6
	16.7	15.62	12.25	5.51	12.25	5.64	12.2	5.78	12.2	5.84	12.2	5.91	12.05	5.97
	19.4	18.32	12.69	5.6	12.69	5.73	12.64	5.86	12.64	5.93	12.64	5.99	12.05	5.7
	23	21.92	13.37	5.72	13.32	5.84	13.32	5.96	13.27	6.03	12.93	5.84	12.05	5.36
	26.6	25.34	14.01	5.83	14.01	5.95	13.86	5.97	13.37	5.73	12.93	5.5	12.05	5.05
	32	30.74	15.18	6	14.74	5.85	13.86	5.42	13.37	5.2	12.93	5	12.05	4.59
	37.4	35.96	15.62	5.71	14.74	5.32	13.86	4.93	13.37	4.75	12.93	4.56	12.05	4.2
	41	39.38	15.62	5.37	14.74	5	13.86	4.65	13.37	4.47	12.93	4.3	12.05	3.96
	44.6	42.8	15.62	5.05	14.74	4.72	13.86	4.38	13.37	4.22	12.93	4.06	12.05	3.74
	48.2	46.22	15.62	4.76	14.74	4.44	13.86	4.13	13.37	3.98	12.93	3.83	12.05	3.54
	51.8	49.64	15.62	4.48	14.74	4.19	13.86	3.9	13.37	3.76	12.93	3.62	12.05	3.35
	55.4	53.24	15.62	4.22	14.74	3.95	13.86	3.68	13.37	3.55	12.93	3.42	12.05	3.16
59	56.66	15.62	3.99	14.74	3.73	13.86	3.48	13.37	3.36	12.93	3.24	12.05	3	
80%	7.34	5	10.71	5.44	10.66	5.58	10.66	5.72	10.66	5.78	10.61	5.86	10.61	6
	10.76	8.6	11.15	5.55	11.15	5.69	11.1	5.82	11.1	5.88	11.1	5.95	10.76	5.79
	14.36	12.2	11.68	5.66	11.68	5.79	11.64	5.92	11.64	5.98	11.54	5.96	10.76	5.47
	14.9	14	11.98	5.72	11.93	5.84	11.93	5.96	11.93	6.03	11.54	5.79	10.76	5.31
	16.7	15.62	12.22	5.77	11.36	5.89	12.17	6.01	11.93	5.87	11.54	5.64	10.76	5.17
	19.4	18.32	12.66	5.86	12.66	5.97	12.32	5.84	11.93	5.61	11.54	5.38	10.76	4.94
	23	21.92	13.35	5.96	13.1	5.93	12.32	5.49	11.93	5.28	11.54	5.06	10.76	4.65
	26.6	25.34	13.88	5.99	13.1	5.58	12.32	5.17	11.93	4.97	11.54	4.77	10.76	4.39
	32	30.74	13.88	5.44	13.1	5.06	12.32	4.7	11.93	4.53	11.54	4.35	10.76	4.01
	37.4	35.96	13.88	4.95	13.1	4.62	12.32	4.3	11.93	4.14	11.54	3.98	10.76	3.67
	41	39.38	13.88	4.66	13.1	4.35	12.32	4.05	11.93	3.9	11.54	3.76	10.76	3.47
	44.6	42.8	13.88	4.39	13.1	4.11	12.32	3.83	11.93	3.69	11.54	3.56	10.76	3.29
	48.2	46.22	13.88	4.15	13.1	3.88	12.32	3.61	11.93	3.48	11.54	3.36	10.76	3.11
	51.8	49.64	13.88	3.92	13.1	3.67	12.32	3.42	11.93	3.3	11.54	3.18	10.76	2.95
	55.4	53.24	13.88	3.69	13.1	3.46	12.32	3.23	11.93	3.12	11.54	3.01	10.76	2.79
59	56.66	13.88	3.49	13.1	3.28	12.32	3.07	11.93	2.96	11.54	2.85	10.76	2.65	

**MDV-V140W/DVN1**  
**Heating**

Combination (%) (Capacity index)	Outdoor Air temperature(°F)		Indoor temperature(°F WB)											
			60.8		64.4		68		69.8		71.6		75.2	
	°F DB	°F WB	TC	PI	TC	PI	TC	PI	TC	PI	TC	PI	TC	PI
70%	7.34	5	10.63	5.75	10.58	5.87	10.58	5.99	10.39	5.9	10.05	5.66	9.37	5.19
	10.76	8.6	11.07	5.84	11.07	5.96	10.78	5.82	10.39	5.59	10.05	5.37	9.37	4.92
	14.36	12.2	11.61	5.94	11.46	5.93	10.78	5.49	10.39	5.28	10.05	5.07	9.37	4.66
	14.9	14	11.9	5.99	11.46	5.76	10.78	5.33	10.39	5.13	10.05	4.93	9.37	4.53
	16.7	15.62	12.15	6.02	11.46	5.6	10.78	5.19	10.39	4.99	10.05	4.8	9.37	4.41
	19.4	18.32	12.15	5.75	11.46	5.35	10.78	4.97	10.39	4.78	10.05	4.59	9.37	4.23
	23	21.92	12.15	5.4	11.46	5.04	10.78	4.68	10.39	4.5	10.05	5.31	9.37	3.99
	26.6	25.34	12.15	5.09	11.46	4.75	10.78	4.41	10.39	4.24	10.05	4.08	9.37	3.77
	32	30.74	12.15	4.63	11.46	4.33	10.78	4.03	10.39	3.88	10.05	3.74	9.37	3.45
	37.4	35.96	12.15	4.23	11.46	3.96	10.78	3.69	10.39	3.56	10.05	3.43	9.37	3.17
	41	39.38	12.15	3.99	11.46	3.74	10.78	3.49	10.39	3.36	10.05	3.24	9.37	3
	44.6	42.8	12.15	3.77	11.46	3.54	10.78	3.3	10.39	3.18	10.05	3.07	9.37	2.85
	48.2	46.22	12.15	3.57	11.46	3.34	10.78	3.12	10.39	3.01	10.05	2.91	9.37	2.7
	51.8	49.64	12.15	3.38	11.46	3.16	10.78	2.96	10.39	2.86	10.05	2.76	9.37	2.56
	55.4	53.24	12.15	3.19	11.46	3	10.78	2.8	10.39	2.71	10.05	2.62	9.37	2.43
59	56.66	12.15	3.02	11.46	2.84	10.78	2.66	10.39	2.58	10.05	2.49	9.37	2.32	
60%	7.34	5	10.41	5.9	9.83	5.49	9.24	5.09	8.95	4.9	8.65	4.7	8.07	4.32
	10.76	8.6	10.41	5.58	9.83	5.2	9.24	4.82	8.95	4.64	8.65	4.46	8.07	4.13
	14.36	12.2	10.41	5.28	9.83	4.91	9.24	4.57	8.95	4.39	8.65	4.23	8.07	3.9
	14.9	14	10.41	5.13	9.83	4.78	9.24	4.44	8.95	4.28	8.65	4.11	8.07	3.79
	16.7	15.62	10.41	4.99	9.83	4.66	9.24	4.33	8.95	4.17	8.65	4.01	8.07	3.7
	19.4	18.32	10.41	4.77	9.83	4.46	9.24	4.14	8.95	3.99	8.65	3.84	8.07	3.55
	23	21.92	10.41	4.5	9.83	4.2	9.24	3.91	8.95	3.77	8.65	3.63	8.07	3.36
	26.6	25.34	10.41	4.24	9.83	3.97	9.24	3.7	8.95	3.57	8.65	3.43	8.07	3.18
	32	30.74	10.41	3.88	9.83	3.63	9.24	3.39	8.95	3.27	8.65	3.15	8.07	2.92
	37.4	35.96	10.41	3.56	9.83	3.34	9.24	3.12	8.95	3.01	8.65	2.91	8.07	2.69
	41	39.38	10.41	3.36	9.83	3.16	9.24	2.95	8.95	2.85	8.65	2.75	8.07	2.56
	44.6	42.8	10.41	3.18	9.83	2.99	9.24	2.8	8.95	2.71	8.65	2.62	8.07	2.43
	48.2	46.22	10.41	3.01	9.83	2.83	9.24	2.65	8.95	2.57	8.65	2.48	8.07	2.31
	51.8	49.64	10.41	2.86	9.83	2.69	9.24	2.52	8.95	2.44	8.65	2.36	8.07	2.2
	55.4	53.24	10.41	2.71	9.83	2.55	9.24	2.4	8.95	2.32	8.65	2.24	8.07	2.09
59	56.66	10.41	2.58	9.83	2.42	9.24	2.28	8.95	2.21	8.65	2.14	8.07	2	
50%	7.34	5	8.67	4.73	8.19	4.41	7.7	4.1	7.41	3.95	7.16	3.81	6.68	3.52
	10.76	8.6	8.67	4.49	8.19	4.19	7.7	3.9	7.41	3.76	7.16	3.62	6.68	3.35
	14.36	12.2	8.67	4.25	8.19	3.97	7.7	3.7	7.41	3.57	7.16	3.44	6.68	3.18
	14.9	14	8.67	4.14	8.19	3.86	7.7	3.61	7.41	3.48	7.16	3.35	6.68	3.1
	16.7	15.62	8.67	4.03	8.19	3.77	7.7	3.52	7.41	3.39	7.16	3.27	6.68	3.03
	19.4	18.32	8.67	3.86	8.19	3.62	7.7	3.38	7.41	3.26	7.16	3.14	6.68	2.91
	23	21.92	8.67	3.65	8.19	3.42	7.7	3.19	7.41	3.09	7.16	2.98	6.68	2.76
	26.6	25.34	8.67	3.45	8.19	3.24	7.7	3.03	7.41	2.92	7.16	2.82	6.68	2.62
	32	30.74	8.67	3.17	8.19	2.98	7.7	2.79	7.41	2.69	7.16	2.6	6.68	2.42
	37.4	35.96	8.67	2.92	8.19	2.74	7.7	2.57	7.41	2.49	7.16	2.4	6.68	2.24
	41	39.38	8.67	2.77	8.19	2.6	7.7	2.44	7.41	2.36	7.16	2.29	6.68	2.13
	44.6	42.8	8.67	2.63	8.19	2.47	7.7	2.33	7.41	2.25	7.16	2.18	6.68	2.04
	48.2	46.22	8.67	2.49	8.19	2.35	7.7	2.21	7.41	2.14	7.16	2.07	6.68	1.94
	51.8	49.64	8.67	2.37	8.19	2.24	7.7	2.11	7.41	2.04	7.16	1.98	6.68	1.85
	55.4	53.24	8.67	2.25	8.19	2.13	7.7	2	7.41	1.95	7.16	1.88	6.68	1.76
59	56.66	8.67	2.14	8.19	2.03	7.7	1.91	7.41	1.86	7.16	1.8	6.68	1.69	

**Note:**

1. [ ] is tested under our standard condition.
2. Avoid to run the unit when the temperature is below 5°F (-15°C).
3. The above table shows the average value of conditions may operate.
4. It is recommended to connect less than 130%.

**MDV-V160W/DVN1**

**Cooling**

Combination (%) (Capacity index)	Outdoor temperature (°F DB)	Indoor temperature(°F DB/WB)													
		DB:69.4,WB:57.2		DB:73.9,WB:60.8		DB:78.4,WB:64.4		DB:80.6,WB:66.2		DB:82.7,WB:68		DB:87.3,WB:71.6		DB:89.6,WB:75.2	
		TC	PI	TC	PI	TC	PI	TC	PI	TC	PI	TC	PI	TC	PI
		kW	kW	kW	kW	kW	kW	kW	kW	kW	kW	kW	kW	kW	kW
130%	23	13.62	1.85	16.22	2.26	18.82	2.42	19.54	2.52	20.48	2.59	20.98	2.81	21.51	2.83
	28.4	13.62	1.85	16.22	2.3	18.82	2.42	19.54	2.53	20.48	2.59	20.98	2.85	21.51	2.86
	32	13.62	1.88	16.22	2.34	18.82	2.51	19.54	2.67	20.48	2.74	20.98	2.88	21.51	2.9
	35.6	13.62	1.91	16.22	2.34	18.82	2.59	19.54	2.82	20.48	2.77	20.98	2.9	21.51	2.94
	39.2	13.62	1.96	16.22	2.39	18.82	2.68	19.54	2.83	20.48	2.8	20.98	2.9	21.51	3
	42.8	13.62	1.99	16.22	2.44	18.82	2.78	19.54	2.86	20.25	2.89	20.72	2.9	21.27	3.02
	46.4	13.62	2.04	16.22	2.49	18.82	2.92	19.54	2.99	20	2.99	20.5	3.9	21	3.05
	50	13.62	2.08	16.22	2.55	18.82	3.03	19.54	3.09	19.76	4.04	20.26	4.06	20.76	3.14
	53.6	13.62	2.12	16.22	2.6	18.82	3.09	19.26	4.03	19.54	4.06	19.98	4.07	20.48	3.16
	57.2	13.62	2.16	16.22	2.64	18.77	4.05	19.04	4.06	19.26	4.08	19.76	4.09	20.26	3.23
	60.8	13.62	2.2	16.22	2.7	18.54	4.06	18.77	4.08	18.99	4.1	19.49	4.12	19.98	3.28
	64.4	13.62	2.24	16.22	2.75	18.27	3.23	18.49	3.25	18.77	3.27	19.26	3.3	19.76	3.33
	68	13.62	2.29	16.22	2.93	17.99	3.39	18.27	3.41	18.49	3.42	18.99	3.45	19.49	3.49
	69.8	13.62	2.35	16.22	3.03	17.88	3.47	18.16	3.48	18.38	3.5	18.88	3.54	19.37	3.57
	73.4	13.62	2.52	16.22	3.25	17.66	3.62	17.88	3.64	18.1	3.66	18.6	3.7	19.1	3.73
	77	13.62	2.69	16.22	3.48	17.38	3.78	17.6	3.8	17.88	3.83	18.38	3.86	18.88	3.9
	80.6	13.62	2.88	16.22	3.73	17.16	3.94	17.38	3.97	17.6	3.98	18.1	4.03	18.6	4.07
	84.2	13.62	3.07	16.22	3.98	16.88	4.1	17.1	4.12	17.38	4.15	17.88	4.19	18.38	4.23
	87.8	13.62	3.28	16.16	4.22	16.61	4.26	16.88	4.29	17.1	4.31	17.6	4.36	18.1	4.4
	91.4	13.62	3.49	15.89	4.37	16.39	4.42	16.61	4.45	16.88	4.47	17.38	4.52	17.82	4.57
95	13.62	3.72	15.61	4.53	16.11	4.59	16.39	4.61	16.61	4.64	17.1	4.69	17.6	4.74	
98.6	13.62	3.96	15.39	4.7	15.89	4.75	16.11	4.78	16.39	4.81	16.83	4.86	17.33	4.92	
102.2	13.62	4.22	15.11	4.75	15.61	4.91	15.89	4.94	16.11	4.97	16.61	5.03	17.1	5.09	
105.8	13.62	4.44	14.96	4.79	15.45	4.96	15.72	4.99	15.94	5.02	16.44	5.04	16.45	5.13	
109.4	13.62	4.55	14.85	4.82	15.36	4.97	15.64	5.01	15.78	5.02	16.14	5.05	16.25	5.14	
120%	23	12.57	1.78	14.95	2.16	17.38	2.56	18.6	2.79	19.49	2.91	19.93	3	20.37	3.08
	28.4	12.57	1.8	14.95	2.18	17.38	2.58	18.6	2.8	19.49	2.94	19.93	3.02	20.37	3.09
	32	12.57	1.82	14.95	2.2	17.38	2.61	18.6	2.81	19.49	2.97	19.93	3.04	20.37	3.1
	35.6	12.57	1.82	14.95	2.22	17.38	2.63	18.6	2.84	19.49	2.98	19.93	3.06	20.37	3.1
	39.2	12.57	1.84	14.95	2.25	17.38	2.67	18.6	2.86	19.49	3.02	19.93	3.07	20.37	3.11
	42.8	12.57	1.86	14.95	2.27	17.38	2.7	18.6	2.9	19.49	3.05	19.93	3.1	20.37	3.12
	46.4	12.57	1.88	14.95	2.29	17.38	2.73	18.6	2.93	19.49	3.08	19.93	3.11	20.37	3.13
	50	12.57	1.9	14.95	2.32	17.38	2.76	18.6	2.98	19.49	3.08	19.93	3.12	20.37	3.15
	53.6	12.57	1.94	14.95	2.36	17.38	2.81	18.6	3.04	19.21	3.1	19.65	3.1	20.09	3.17
	57.2	12.57	1.97	14.95	2.41	17.38	2.87	18.6	3.1	18.93	3.12	19.43	3.14	19.87	3.21
	60.8	12.57	2.01	14.95	2.46	17.38	2.92	18.49	4.1	18.71	3.16	19.15	3.2	19.6	3.26
	64.4	12.57	2.05	14.95	2.51	17.38	3.02	18.21	3.23	18.43	3.24	18.88	3.27	19.37	3.3
	68	12.57	2.09	14.95	2.61	17.38	3.25	17.99	3.39	18.21	3.4	18.66	3.43	19.1	3.46
	69.8	12.57	2.11	14.95	2.7	17.38	3.37	17.82	3.47	18.05	3.48	18.54	3.51	18.99	3.55
	73.4	12.57	2.25	14.95	2.89	17.38	3.61	17.6	3.62	17.82	3.64	18.27	3.67	18.71	3.7
	77	12.57	2.41	14.95	3.09	17.1	3.76	17.33	3.78	17.55	3.8	18.05	3.83	18.49	3.87
	80.6	12.57	2.57	14.95	3.31	16.88	3.92	17.1	3.94	17.33	3.96	17.77	4	18.21	4.03
	84.2	12.57	2.74	14.95	3.53	16.61	4.08	16.83	4.1	17.05	4.12	17.49	4.16	17.99	4.2
	87.8	12.57	2.92	14.95	3.77	16.33	4.24	16.61	4.26	16.83	4.28	17.27	4.32	17.71	4.37
	91.4	12.57	3.11	14.95	4.02	16.11	4.4	16.33	4.42	16.55	4.44	16.99	4.49	17.44	4.53
95	12.57	3.31	14.95	4.29	15.83	4.56	16.05	4.58	16.33	4.61	16.77	4.65	17.22	4.7	
98.6	12.57	3.53	14.95	4.57	15.61	4.72	15.83	4.75	16.05	4.77	16.5	4.82	16.94	4.87	
102.2	12.57	3.75	14.89	4.82	15.33	4.88	15.56	4.91	15.78	4.93	16.27	4.99	16.72	5.04	
105.8	12.57	3.86	14.77	4.86	15.21	4.91	15.44	4.94	15.66	4.97	16.15	5	16.24	5.08	
109.4	12.57	3.91	14.69	4.89	15.09	4.94	15.31	4.96	15.54	4.99	15.87	5.02	15.98	5.18	

**MDV-V160W/DVN1**  
**Cooling**

Combination (%) (Capacity index)	Outdoor temperature (°F DB)	Indoor temperature(°F DB/WB)													
		DB:69.4,WB:57.2		DB:73.9,WB:60.8		DB:78.4,WB:64.4		DB:80.6,WB:66.2		DB:82.7,WB:68		DB:87.3,WB:71.6		DB:89.6,WB:75.2	
		TC	PI	TC	PI	TC	PI	TC	PI	TC	PI	TC	PI	TC	PI
		kW	kW	kW	kW	kW	kW	kW	kW	kW	kW	kW	kW	kW	kW
110%	23	11.51	1.56	13.73	1.94	15.94	2.31	17.05	2.48	18.16	2.67	19.54	2.78	19.99	2.86
	28.4	11.51	1.59	13.73	1.97	15.94	2.33	17.05	2.51	18.16	2.69	19.54	2.8	19.99	2.88
	32	11.51	1.6	13.73	1.98	15.94	2.35	17.05	2.53	18.16	2.72	19.54	2.83	19.99	2.91
	35.6	11.51	1.64	13.73	2	15.94	2.39	17.05	2.55	18.16	2.75	19.54	2.87	19.99	2.95
	39.2	11.51	1.67	13.73	2.02	15.94	2.41	17.05	2.58	18.16	2.8	19.54	2.91	19.99	2.98
	42.8	11.51	1.69	13.73	2.04	15.94	2.44	17.05	2.63	18.16	2.83	19.54	2.94	19.99	3.02
	46.4	11.51	1.7	13.73	2.07	15.94	2.46	17.05	2.65	18.16	2.86	19.54	2.96	19.99	3.05
	50	11.51	1.72	13.73	2.1	15.94	2.5	17.05	2.7	18.16	2.91	19.54	2.98	19.99	3.08
	53.6	11.51	1.76	13.73	2.14	15.94	2.55	17.05	2.75	18.16	2.96	19.32	3.03	19.71	3.12
	57.2	11.51	1.79	13.73	2.18	15.94	2.6	17.05	2.8	18.16	3.02	19.04	3.05	19.49	3.14
	60.8	11.51	1.82	13.73	2.22	15.94	2.64	17.05	2.86	18.16	3.08	18.82	3.09	19.21	3.18
	64.4	11.51	1.86	13.73	2.27	15.94	2.7	17.05	2.94	18.16	3.22	18.54	3.25	18.99	3.28
	68	11.51	1.89	13.73	2.31	15.94	2.86	17.05	3.16	17.88	3.38	18.32	3.41	18.71	3.44
	69.8	11.51	1.91	13.73	2.38	15.94	2.96	17.05	3.27	17.77	3.46	18.16	3.48	18.6	3.51
	73.4	11.51	2	13.73	2.55	15.94	3.17	17.05	3.51	17.49	3.61	17.94	3.65	18.32	3.68
	77	11.51	2.14	13.73	2.73	15.94	3.39	17.05	3.76	17.27	3.77	17.66	3.81	18.1	3.84
	80.6	11.51	2.28	13.73	2.92	15.94	3.63	16.77	3.92	17	3.93	17.44	3.97	17.83	4
	84.2	11.51	2.43	13.73	3.11	15.94	3.88	16.55	4.08	16.77	4.09	17.16	4.13	17.6	4.17
	87.8	11.51	2.59	13.73	3.32	15.94	4.14	16.28	4.23	16.5	4.25	16.94	4.29	17.33	4.33
	91.4	11.51	2.75	13.73	3.54	15.83	4.37	16.05	4.39	16.28	4.41	16.66	4.45	17.11	4.5
95	11.51	2.93	13.73	3.77	15.56	4.53	15.78	4.55	16	4.58	16.39	4.62	16.83	4.66	
98.6	11.51	3.12	13.73	4.01	15.33	4.69	15.56	4.71	15.72	4.73	16.17	4.78	16.55	4.82	
102.2	11.51	3.31	13.73	4.28	15.06	4.85	15.28	4.87	15.5	4.9	15.89	4.95	16.33	5	
105.8	11.51	3.35	13.73	4.31	14.94	4.88	15.16	4.91	15.38	4.93	15.69	4.98	15.84	5.03	
109.4	11.51	3.38	13.73	4.37	14.82	4.92	15.04	4.94	15.26	4.97	15.55	5	15.6	5.13	
100%	23	10.46	1.42	12.46	1.71	14.5	2.03	15.5	2.18	16.5	2.36	18.54	2.69	19.6	2.81
	28.4	10.46	1.44	12.46	1.73	14.5	2.06	15.5	2.22	16.5	2.4	18.54	2.73	19.6	2.83
	32	10.46	1.45	12.46	1.75	14.5	2.08	15.5	2.25	16.5	2.42	18.54	2.77	19.6	2.86
	35.6	10.46	1.48	12.46	1.77	14.5	2.1	15.5	2.28	16.5	2.45	18.54	2.81	19.6	2.91
	39.2	10.46	1.49	12.46	1.79	14.5	2.13	15.5	2.31	16.5	2.48	18.54	2.84	19.6	2.94
	42.8	10.46	1.51	12.46	1.83	14.5	2.16	15.5	2.35	16.5	2.51	18.54	2.88	19.6	2.98
	46.4	10.46	1.54	12.46	1.85	14.5	2.2	15.5	2.38	16.5	2.55	18.54	2.92	19.6	3.03
	50	10.46	1.56	12.46	1.89	14.5	2.24	15.5	2.42	16.5	2.6	18.54	2.97	19.6	3.08
	53.6	10.46	1.58	12.46	1.93	14.5	2.28	15.5	2.46	16.5	2.65	18.54	3.03	19.32	3.1
	57.2	10.46	1.61	12.46	1.96	14.5	2.32	15.5	2.51	16.5	2.7	18.54	3.09	19.1	3.14
	60.8	10.46	1.64	12.46	2	14.5	2.37	15.5	2.56	16.5	2.75	18.43	3.13	18.82	3.17
	64.4	10.46	1.68	12.46	2.03	14.5	2.41	15.5	2.61	16.5	2.81	18.21	3.23	18.6	3.25
	68	10.46	1.71	12.46	2.08	14.5	2.49	15.5	2.74	16.5	3.01	17.94	3.38	18.32	3.41
	69.8	10.46	1.72	12.46	2.1	14.5	2.58	15.5	2.84	16.5	3.11	17.83	3.46	18.21	3.49
	73.4	10.46	1.77	12.46	2.24	14.5	2.76	15.5	3.04	16.5	3.34	17.6	3.62	17.94	3.65
	77	10.46	1.88	12.46	2.39	14.5	2.95	15.5	3.26	16.5	3.58	17.33	3.78	17.71	3.81
	80.6	10.46	2.01	12.46	2.55	14.5	3.16	15.5	3.48	16.5	3.83	17.05	3.94	17.44	3.97
	84.2	10.46	2.14	12.46	2.72	14.5	3.37	15.5	3.72	16.44	4.06	16.83	4.1	17.22	4.13
	87.8	10.46	2.28	12.46	2.9	14.5	3.59	15.5	3.97	16.22	4.22	16.55	4.26	16.94	4.29
	91.4	10.46	2.42	12.46	3.09	14.5	3.83	15.5	4.24	15.94	4.38	16.33	4.42	16.72	4.46
95	10.46	2.57	12.46	3.28	14.5	4.09	15.5	4.52	15.67	4.54	16.05	4.58	16.44	4.62	
98.6	10.46	2.74	12.46	3.5	14.5	4.36	15.22	4.68	15.44	4.7	15.83	4.74	16.16	4.78	
102.2	10.46	2.91	12.46	3.72	14.5	4.64	15	4.84	15.17	4.86	15.56	4.9	15.94	4.95	
105.8	10.46	3.04	12.46	3.85	14.5	4.81	14.77	4.87	15.05	4.94	15.29	5.02	15.71	5.05	
109.4	10.46	3.18	12.46	3.99	14.5	4.89	14.54	4.93	14.94	4.98	15.38	5.05	15.43	5.11	

**MDV-V160W/DVN1**

**Cooling**

Combination (%) (Capacity index)	Outdoor temperature (°F DB)	Indoor temperature(°F DB/WB)													
		DB:69.4,WB:57.2		DB:73.9,WB:60.8		DB:78.4,WB:64.4		DB:80.6,WB:66.2		DB:82.7,WB:68		DB:87.3,WB:71.6		DB:89.6,WB:75.2	
		TC	PI	TC	PI	TC	PI	TC	PI	TC	PI	TC	PI	TC	PI
		kW	kW	kW	kW	kW	kW	kW	kW	kW	kW	kW	kW	kW	kW
90%	23	9.41	1.26	11.24	1.51	13.06	1.78	13.95	1.94	14.84	2.06	16.66	2.37	18.49	2.72
	28.4	9.41	1.27	11.24	1.52	13.06	1.8	13.95	1.97	14.84	2.09	16.66	2.39	18.49	2.74
	32	9.41	1.29	11.24	1.54	13.06	1.83	13.95	1.99	14.84	2.11	16.66	2.42	18.49	2.76
	35.6	9.41	1.31	11.24	1.56	13.06	1.85	13.95	2.02	14.84	2.15	16.66	2.47	18.49	2.8
	39.2	9.41	1.33	11.24	1.58	13.06	1.88	13.95	2.05	14.84	2.17	16.66	2.51	18.49	2.84
	42.8	9.41	1.34	11.24	1.61	13.06	1.91	13.95	2.09	14.84	2.21	16.66	2.55	18.49	2.89
	46.4	9.41	1.37	11.24	1.65	13.06	1.95	13.95	2.11	14.84	2.25	16.66	2.6	18.49	2.92
	50	9.41	1.39	11.24	1.68	13.06	1.99	13.95	2.14	14.84	2.3	16.66	2.63	18.49	2.97
	53.6	9.41	1.42	11.24	1.71	13.06	2.02	13.95	2.18	14.84	2.35	16.66	2.68	18.49	3.02
	57.2	9.41	1.44	11.24	1.74	13.06	2.06	13.95	2.22	14.84	2.39	16.66	2.73	18.49	3.08
	60.8	9.41	1.47	11.24	1.77	13.06	2.1	13.95	2.27	14.84	2.44	16.66	2.78	18.43	3.13
	64.4	9.41	1.49	11.24	1.81	13.06	2.14	13.95	2.31	14.84	2.49	16.66	2.84	18.21	3.23
	68	9.41	1.52	11.24	1.85	13.06	2.18	13.95	2.36	14.84	2.58	16.66	3.05	17.94	3.38
	69.8	9.41	1.54	11.24	1.86	13.06	2.22	13.95	2.44	14.84	2.67	16.66	3.16	17.83	3.46
	73.4	9.41	1.57	11.24	1.94	13.06	2.38	13.95	2.61	14.84	2.86	16.66	3.39	17.55	3.62
	77	9.41	1.65	11.24	2.07	13.06	2.54	13.95	2.8	14.84	3.06	16.66	3.63	17.33	3.78
	80.6	9.41	1.75	11.24	2.21	13.06	2.71	13.95	2.98	14.84	3.27	16.66	3.89	17.05	3.93
	84.2	9.41	1.87	11.24	2.35	13.06	2.89	13.95	3.19	14.84	3.5	16.5	4.06	16.83	4.09
	87.8	9.41	1.99	11.24	2.5	13.06	3.08	13.95	3.4	14.84	3.73	16.22	4.22	16.55	4.26
	91.4	9.41	2.11	11.24	2.66	13.06	3.29	13.95	3.62	14.84	3.98	16	4.39	16.33	4.42
95	9.41	2.24	11.24	2.83	13.06	3.5	13.95	3.86	14.84	4.24	15.72	4.54	16.05	4.58	
98.6	9.41	2.38	11.24	3.01	13.06	3.73	13.95	4.11	14.84	4.52	15.44	4.7	15.83	4.74	
102.2	9.41	2.52	11.24	3.2	13.06	3.97	13.95	4.38	14.84	4.81	15.22	4.87	15.56	4.9	
105.8	9.41	2.61	11.24	3.35	13.06	4.11	13.95	4.5	14.84	4.84	15.12	4.99	15.45	5.02	
109.4	9.41	2.73	11.24	3.49	13.06	4.26	13.95	4.61	14.84	4.94	15.04	5.06	15.32	5.1	
80%	23	8.36	1.11	9.96	1.31	11.57	1.55	12.4	1.65	13.23	1.77	14.84	2.05	16.44	2.34
	28.4	8.36	1.12	9.96	1.32	11.57	1.56	12.4	1.67	13.23	1.79	14.84	2.07	16.44	2.36
	32	8.36	1.14	9.96	1.34	11.57	1.58	12.4	1.69	13.23	1.82	14.84	2.1	16.44	2.39
	35.6	8.36	1.16	9.96	1.36	11.57	1.6	12.4	1.72	13.23	1.85	14.84	2.14	16.44	2.44
	39.2	8.36	1.18	9.96	1.38	11.57	1.63	12.4	1.76	13.23	1.89	14.84	2.18	16.44	2.47
	42.8	8.36	1.2	9.96	1.42	11.57	1.66	12.4	1.8	13.23	1.92	14.84	2.21	16.44	2.51
	46.4	8.36	1.23	9.96	1.45	11.57	1.7	12.4	1.83	13.23	1.96	14.84	2.24	16.44	2.56
	50	8.36	1.24	9.96	1.48	11.57	1.74	12.4	1.88	13.23	2.01	14.84	2.3	16.44	2.59
	53.6	8.36	1.26	9.96	1.5	11.57	1.77	12.4	1.91	13.23	2.05	14.84	2.34	16.44	2.64
	57.2	8.36	1.28	9.96	1.54	11.57	1.8	12.4	1.94	13.23	2.09	14.84	2.38	16.44	2.69
	60.8	8.36	1.3	9.96	1.56	11.57	1.84	12.4	1.98	13.23	2.13	14.84	2.43	16.44	2.74
	64.4	8.36	1.32	9.96	1.59	11.57	1.88	12.4	2.02	13.23	2.17	14.84	2.48	16.44	2.79
	68	8.36	1.35	9.96	1.62	11.57	1.91	12.4	2.06	13.23	2.21	14.84	2.57	16.44	2.98
	69.8	8.36	1.36	9.96	1.63	11.57	1.93	12.4	2.08	13.23	2.26	14.84	2.66	16.44	3.09
	73.4	8.36	1.38	9.96	1.67	11.57	2.02	12.4	2.22	13.23	2.42	14.84	2.85	16.44	3.32
	77	8.36	1.43	9.96	1.77	11.57	2.16	12.4	2.37	13.23	2.58	14.84	3.05	16.44	3.55
	80.6	8.36	1.52	9.96	1.89	11.57	2.3	12.4	2.53	13.23	2.76	14.84	3.26	16.44	3.8
	84.2	8.36	1.61	9.96	2.01	11.57	2.46	12.4	2.69	13.23	2.95	14.84	3.48	16.44	4.06
	87.8	8.36	1.71	9.96	2.14	11.57	2.61	12.4	2.87	13.23	3.14	14.84	3.72	16.16	4.22
	91.4	8.36	1.82	9.96	2.27	11.57	2.78	12.4	3.06	13.23	3.34	14.84	3.96	15.94	4.38
95	8.36	1.93	9.96	2.42	11.57	2.96	12.4	3.25	13.23	3.56	14.84	4.22	15.67	4.54	
98.6	8.36	2.05	9.96	2.56	11.57	3.15	12.4	3.47	13.23	3.8	14.84	4.5	15.44	4.7	
102.2	8.36	2.17	9.96	2.74	11.57	3.35	12.4	3.69	13.23	4.04	14.84	4.79	15.17	4.86	
105.8	8.36	2.22	9.96	2.76	11.57	3.4	12.4	3.78	13.23	4.11	14.84	4.92	15.07	4.95	
109.4	8.36	2.28	9.96	2.78	11.57	3.45	12.4	3.85	13.23	4.17	14.84	4.97	14.98	5	

**MDV-V160W/DVN1**  
**Cooling**

Combination (%) (Capacity index)	Outdoor temperature (°F DB)	Indoor temperature(°F DB/WB)													
		DB:69.4,WB:57.2		DB:73.9,WB:60.8		DB:78.4,WB:64.4		DB:80.6,WB:66.2		DB:82.7,WB:68		DB:87.3,WB:71.6		DB:89.6,WB:75.2	
		TC	PI	TC	PI	TC	PI	TC	PI	TC	PI	TC	PI	TC	PI
		kW	kW	kW	kW	kW	kW	kW	kW	kW	kW	kW	kW	kW	kW
70%	23	7.31	0.99	8.75	1.16	10.13	1.31	10.85	1.41	11.57	1.5	12.95	1.72	14.39	1.97
	28.4	7.31	1	8.75	1.16	10.13	1.32	10.85	1.43	11.57	1.53	12.95	1.74	14.39	2
	32	7.31	1	8.75	1.18	10.13	1.35	10.85	1.46	11.57	1.56	12.95	1.78	14.39	2.03
	35.6	7.31	1.01	8.75	1.18	10.13	1.37	10.85	1.49	11.57	1.58	12.95	1.82	14.39	2.06
	39.2	7.31	1.02	8.75	1.21	10.13	1.4	10.85	1.51	11.57	1.62	12.95	1.85	14.39	2.11
	42.8	7.31	1.04	8.75	1.24	10.13	1.43	10.85	1.56	11.57	1.66	12.95	1.88	14.39	2.15
	46.4	7.31	1.05	8.75	1.27	10.13	1.47	10.85	1.59	11.57	1.69	12.95	1.93	14.39	2.19
	50	7.31	1.08	8.75	1.29	10.13	1.5	10.85	1.62	11.57	1.74	12.95	1.97	14.39	2.22
	53.6	7.31	1.1	8.75	1.31	10.13	1.54	10.85	1.65	11.57	1.77	12.95	2.01	14.39	2.26
	57.2	7.31	1.12	8.75	1.33	10.13	1.56	10.85	1.68	11.57	1.8	12.95	2.05	14.39	2.3
	60.8	7.31	1.14	8.75	1.36	10.13	1.59	10.85	1.71	11.57	1.83	12.95	2.08	14.39	2.35
	64.4	7.31	1.16	8.75	1.38	10.13	1.62	10.85	1.74	11.57	1.86	12.95	2.13	14.39	2.39
	68	7.31	1.18	8.75	1.41	10.13	1.65	10.85	1.77	11.57	1.9	12.95	2.17	14.39	2.46
	69.8	7.31	1.19	8.75	1.42	10.13	1.66	10.85	1.79	11.57	1.92	12.95	2.2	14.39	2.55
	73.4	7.31	1.21	8.75	1.44	10.13	1.7	10.85	1.85	11.57	2.02	12.95	2.36	14.39	2.73
	77	7.31	1.23	8.75	1.5	10.13	1.81	10.85	1.98	11.57	2.15	12.95	2.52	14.39	2.92
	80.6	7.31	1.3	8.75	1.6	10.13	1.93	10.85	2.11	11.57	2.3	12.95	2.69	14.39	3.12
	84.2	7.31	1.38	8.75	1.7	10.13	2.05	10.85	2.25	11.57	2.44	12.95	2.87	14.39	3.33
	87.8	7.31	1.46	8.75	1.8	10.13	2.19	10.85	2.39	11.57	2.6	12.95	3.06	14.39	3.55
	91.4	7.31	1.55	8.75	1.92	10.13	2.33	10.85	2.54	11.57	2.77	12.95	3.26	14.39	3.79
95	7.31	1.64	8.75	2.03	10.13	2.47	10.85	2.7	11.57	2.95	12.95	3.47	14.39	4.04	
98.6	7.31	1.74	8.75	2.16	10.13	2.63	10.85	2.87	11.57	3.14	12.95	3.7	14.39	4.3	
102.2	7.31	1.84	8.75	2.28	10.13	2.78	10.85	3.05	11.57	3.33	12.95	3.93	14.39	4.58	
105.8	7.31	1.92	8.75	2.37	10.13	2.87	10.85	3.15	11.57	3.43	12.95	4.09	14.39	4.78	
109.4	7.31	2.08	8.75	2.53	10.13	2.98	10.85	3.32	11.57	3.54	12.95	4.24	14.39	4.93	
60%	23	6.26	0.84	7.47	0.98	8.69	1.14	9.3	1.21	9.91	1.31	11.13	1.47	12.34	1.69
	28.4	6.26	0.85	7.47	0.99	8.69	1.16	9.3	1.23	9.91	1.32	11.13	1.49	12.34	1.7
	32	6.26	0.86	7.47	1	8.69	1.17	9.3	1.25	9.91	1.34	11.13	1.51	12.34	1.72
	35.6	6.26	0.88	7.47	1.03	8.69	1.2	9.3	1.27	9.91	1.36	11.13	1.55	12.34	1.74
	39.2	6.26	0.9	7.47	1.05	8.69	1.22	9.3	1.29	9.91	1.38	11.13	1.57	12.34	1.77
	42.8	6.26	0.91	7.47	1.07	8.69	1.24	9.3	1.31	9.91	1.41	11.13	1.6	12.34	1.81
	46.4	6.26	0.93	7.47	1.08	8.69	1.27	9.3	1.34	9.91	1.44	11.13	1.63	12.34	1.84
	50	6.26	0.94	7.47	1.11	8.69	1.29	9.3	1.38	9.91	1.47	11.13	1.66	12.34	1.86
	53.6	6.26	0.96	7.47	1.13	8.69	1.31	9.3	1.4	9.91	1.49	11.13	1.69	12.34	1.89
	57.2	6.26	0.97	7.47	1.14	8.69	1.33	9.3	1.43	9.91	1.52	11.13	1.72	12.34	1.93
	60.8	6.26	0.99	7.47	1.16	8.69	1.35	9.3	1.45	9.91	1.55	11.13	1.75	12.34	1.97
	64.4	6.26	1	7.47	1.18	8.69	1.38	9.3	1.47	9.91	1.58	11.13	1.78	12.34	2
	68	6.26	1.02	7.47	1.21	8.69	1.4	9.3	1.5	9.91	1.61	11.13	1.82	12.34	2.05
	69.8	6.26	1.03	7.47	1.21	8.69	1.41	9.3	1.52	9.91	1.62	11.13	1.84	12.34	2.06
	73.4	6.26	1.04	7.47	1.24	8.69	1.44	9.3	1.55	9.91	1.65	11.13	1.91	12.34	2.2
	77	6.26	1.06	7.47	1.25	8.69	1.49	9.3	1.62	9.91	1.75	11.13	2.04	12.34	2.34
	80.6	6.26	1.1	7.47	1.33	8.69	1.59	9.3	1.73	9.91	1.87	11.13	2.17	12.34	2.5
	84.2	6.26	1.16	7.47	1.41	8.69	1.69	9.3	1.84	9.91	1.99	11.13	2.32	12.34	2.67
	87.8	6.26	1.24	7.47	1.5	8.69	1.8	9.3	1.96	9.91	2.12	11.13	2.47	12.34	2.84
	91.4	6.26	1.3	7.47	1.59	8.69	1.91	9.3	2.08	9.91	2.25	11.13	2.63	12.34	3.03
95	6.26	1.38	7.47	1.69	8.69	2.02	9.3	2.2	9.91	2.39	11.13	2.8	12.34	3.23	
98.6	6.26	1.46	7.47	1.78	8.69	2.14	9.3	2.34	9.91	2.54	11.13	2.97	12.34	3.44	
102.2	6.26	1.54	7.47	1.89	8.69	2.27	9.3	2.48	9.91	2.7	11.13	3.15	12.34	3.65	
105.8	6.26	1.59	7.47	1.97	8.69	2.35	9.3	2.58	9.91	2.8	11.13	3.3	12.34	3.82	
109.4	6.26	1.64	7.47	2.05	8.69	2.44	9.3	2.66	9.91	2.9	11.13	3.44	12.34	3.99	



**MDV-V160W/DVN1**

**Cooling**

Combination (%) (Capacity index)	Outdoor temperature (°F DB)	Indoor temperature(°F DB/WB)													
		DB:69.4,WB:57.2		DB:73.9,WB:60.8		DB:78.4,WB:64.4		DB:80.6,WB:66.2		DB:82.7,WB:68		DB:87.3,WB:71.6		DB:89.6,WB:75.2	
		TC	PI	TC	PI	TC	PI	TC	PI	TC	PI	TC	PI	TC	PI
		kW	kW	kW	kW	kW	kW	kW	kW	kW	kW	kW	kW	kW	kW
50%	23	5.23	0.73	6.26	0.85	7.25	0.97	7.75	1.02	8.25	1.07	9.24	1.22	10.3	1.32
	28.4	5.23	0.74	6.26	0.86	7.25	0.98	7.75	1.03	8.25	1.09	9.24	1.24	10.3	1.33
	32	5.23	0.75	6.26	0.88	7.25	1	7.75	1.05	8.25	1.11	9.24	1.26	10.3	1.36
	35.6	5.23	0.76	6.26	0.89	7.25	1.02	7.75	1.06	8.25	1.12	9.24	1.26	10.3	1.38
	39.2	5.23	0.77	6.26	0.9	7.25	1.03	7.75	1.07	8.25	1.15	9.24	1.29	10.3	1.42
	42.8	5.23	0.78	6.26	0.92	7.25	1.04	7.75	1.1	8.25	1.17	9.24	1.31	10.3	1.46
	46.4	5.23	0.8	6.26	0.93	7.25	1.06	7.75	1.12	8.25	1.18	9.24	1.34	10.3	1.51
	50	5.23	0.82	6.26	0.94	7.25	1.08	7.75	1.14	8.25	1.22	9.24	1.37	10.3	1.53
	53.6	5.23	0.82	6.26	0.96	7.25	1.1	7.75	1.16	8.25	1.24	9.24	1.39	10.3	1.55
	57.2	5.23	0.83	6.26	0.97	7.25	1.11	7.75	1.19	8.25	1.26	9.24	1.42	10.3	1.58
	60.8	5.23	0.85	6.26	0.98	7.25	1.13	7.75	1.21	8.25	1.28	9.24	1.44	10.3	1.61
	64.4	5.23	0.86	6.26	1	7.25	1.15	7.75	1.22	8.25	1.3	9.24	1.47	10.3	1.64
	68	5.23	0.87	6.26	1.01	7.25	1.16	7.75	1.24	8.25	1.33	9.24	1.49	10.3	1.67
	69.8	5.23	0.88	6.26	1.02	7.25	1.18	7.75	1.25	8.25	1.34	9.24	1.51	10.3	1.69
	73.4	5.23	0.89	6.26	1.04	7.25	1.19	7.75	1.28	8.25	1.36	9.24	1.53	10.3	1.72
	77	5.23	0.9	6.26	1.05	7.25	1.22	7.75	1.3	8.25	1.41	9.24	1.61	10.3	1.84
	80.6	5.23	0.92	6.26	1.1	7.25	1.29	7.75	1.39	8.25	1.49	9.24	1.72	10.3	1.96
	84.2	5.23	0.97	6.26	1.16	7.25	1.36	7.75	1.47	8.25	1.59	9.24	1.83	10.3	2.09
	87.8	5.23	1.02	6.26	1.22	7.25	1.44	7.75	1.57	8.25	1.69	9.24	1.94	10.3	2.22
	91.4	5.23	1.08	6.26	1.3	7.25	1.53	7.75	1.66	8.25	1.79	9.24	2.06	10.3	2.36
95	5.23	1.15	6.26	1.37	7.25	1.62	7.75	1.75	8.25	1.89	9.24	2.19	10.3	2.51	
98.6	5.23	1.21	6.26	1.45	7.25	1.72	7.75	1.86	8.25	2.01	9.24	2.33	10.3	2.67	
102.2	5.23	1.27	6.26	1.53	7.25	1.82	7.75	1.97	8.25	2.13	9.24	2.47	10.3	2.83	
105.8	5.23	1.33	6.26	1.59	7.25	1.88	7.75	2.06	8.25	2.22	9.24	2.6	10.3	2.96	
109.4	5.23	1.41	6.26	1.7	7.25	1.95	7.75	2.15	8.25	2.28	9.24	2.73	10.3	3.1	

**Note:**

1. \_\_\_\_\_ is tested under our standard condition.
2. Avoid to run the unit when the temperature is above 109.4°F (43°C).
3. The above table shows the average value of conditions may operate.
4. It is recommended to connect less than 130%.

**MDV-V160W/DVN1**  
**Heating**

Combination (%) (Capacity index)	Outdoor Air temperature(°F)		Indoor temperature(°F WB)											
			60.8		64.4		68		69.8		71.6		75.2	
	°F DB	°F WB	TC	PI	TC	PI	TC	PI	TC	PI	TC	PI	TC	PI
130%	7.34	5	12.09	3.77	12.04	3.99	11.98	4.21	11.98	4.31	11.93	4.42	11.93	4.64
	10.76	8.6	12.58	3.94	12.58	4.15	12.52	4.35	12.47	4.46	12.47	4.57	12.41	4.77
	14.36	12.2	13.17	4.11	13.11	4.31	13.06	4.51	13.06	4.61	13.06	4.71	13.01	4.91
	14.9	14	13.49	4.2	13.44	4.39	13.38	4.58	13.38	4.68	13.33	4.78	13.33	4.97
	16.7	15.62	13.76	4.27	13.71	4.46	13.71	4.65	13.65	4.75	13.65	4.84	13.6	5.03
	19.4	18.32	14.25	4.4	14.25	4.58	14.19	4.76	14.19	4.86	14.14	4.94	14.08	5.13
	23	21.92	15	4.57	14.95	4.74	14.89	4.91	14.89	5	14.84	5.08	14.84	5.25
	26.6	25.34	15.71	4.71	15.65	4.88	15.65	5.04	15.6	5.13	15.6	5.21	15.54	5.37
	32	30.74	16.95	4.94	16.95	5.1	16.89	5.25	16.89	5.3	16.84	5.4	16.84	5.55
	37.4	35.96	18.29	5.15	18.24	5.29	18.19	5.43	18.19	5.5	18.19	5.58	18.13	5.71
	41	39.38	19.21	5.28	19.16	5.41	19.16	5.54	19.11	5.61	19.11	5.68	19.05	5.81
	44.6	42.8	20.18	5.4	20.13	5.53	20.13	5.66	20.08	5.72	20.08	5.78	19.27	5.55
	48.2	46.22	21.21	5.51	21.15	5.64	21.15	5.75	21.1	5.82	20.67	5.69	19.27	5.22
	51.8	49.64	22.29	5.62	22.24	5.74	22.13	5.81	21.37	5.58	20.67	5.35	19.27	4.91
	55.4	53.24	23.48	5.73	23.42	5.84	22.13	5.45	21.37	5.23	20.67	5.02	19.27	4.61
	59	56.66	24.61	5.83	23.53	5.53	22.13	5.13	21.37	4.93	20.67	4.73	19.27	4.35
120%	7.34	5	12.04	4.06	11.98	4.26	11.93	4.46	11.93	4.57	11.93	4.66	11.87	4.86
	10.76	8.6	12.52	4.22	12.52	4.41	12.47	4.6	12.47	4.7	12.41	4.79	12.41	4.99
	14.36	12.2	13.11	4.38	13.06	4.56	13.06	4.75	13.01	4.84	13.01	4.93	12.95	5.11
	14.9	14	13.44	4.46	13.39	4.64	13.33	4.81	13.33	4.91	13.33	4.99	13.28	5.17
	16.7	15.62	13.71	4.53	13.65	4.7	13.65	4.88	13.6	4.96	13.6	5.06	13.55	5.23
	19.4	18.32	14.19	4.65	14.19	4.81	14.14	4.98	14.14	5.07	14.09	5.15	14.09	5.32
	23	21.92	14.95	4.79	14.9	4.96	14.84	5.12	14.84	5.2	14.84	5.28	14.79	5.43
	26.6	25.34	15.65	4.94	15.65	5.09	15.6	5.24	15.6	5.32	15.54	5.4	15.54	5.54
	32	30.74	16.89	5.15	16.89	5.29	16.84	5.43	16.84	5.5	16.78	5.57	16.78	5.71
	37.4	35.96	18.24	5.34	18.19	5.47	18.19	5.6	18.13	5.67	18.13	5.73	17.76	5.7
	41	39.38	19.16	5.46	19.11	5.58	19.11	5.71	19.05	5.77	19.05	5.83	17.76	5.35
	44.6	42.8	20.13	5.57	20.13	5.69	20.08	5.8	19.75	5.72	19.11	5.49	17.76	5.04
	48.2	46.22	21.16	5.68	21.1	5.79	20.4	5.6	19.75	5.38	19.11	5.16	17.76	4.74
	51.8	49.64	22.24	5.78	21.7	5.68	20.4	5.27	19.75	5.06	19.11	4.86	17.76	4.47
	55.4	53.24	23.04	5.72	21.7	5.33	20.4	4.94	19.75	4.75	19.11	4.57	17.76	4.2
	59	56.66	23.04	5.39	21.7	5.02	20.4	4.66	19.75	4.48	19.11	4.31	17.76	3.96
110%	7.34	5	11.98	4.36	11.93	4.54	11.87	4.72	11.87	4.81	11.87	4.91	11.82	5.09
	10.76	8.6	12.47	4.5	12.47	4.68	12.41	4.85	12.41	4.94	12.36	5.02	12.36	5.2
	14.36	12.2	13.06	4.65	13.01	4.81	13.01	4.98	12.95	5.07	12.95	5.15	12.95	5.32
	14.9	14	13.38	4.72	13.33	4.88	13.28	5.05	13.28	5.13	13.28	5.21	13.22	5.37
	16.7	15.62	13.65	4.78	13.6	4.94	13.6	5.1	13.55	5.19	13.55	5.27	13.55	4.8
	19.4	18.32	14.14	4.89	14.14	5.04	14.09	5.2	14.09	5.28	14.09	5.35	14.03	5.51
	23	21.92	14.9	5.03	14.84	5.18	14.79	5.32	14.79	5.4	14.79	5.47	14.73	5.62
	26.6	25.34	15.6	5.16	15.6	5.3	15.54	5.44	15.54	5.51	15.49	5.58	15.49	5.72
	32	30.74	16.84	5.35	16.84	5.48	16.79	5.61	16.79	5.67	16.79	5.74	16.3	5.63
	37.4	35.96	18.19	5.53	18.13	5.65	18.13	5.77	18.08	5.82	17.49	5.59	16.3	5.12
	41	39.38	19.11	5.64	19.11	5.75	18.73	5.7	18.08	5.47	17.49	5.25	16.3	4.82
	44.6	42.8	20.08	5.74	19.91	5.78	18.73	5.35	18.08	5.14	17.49	4.94	16.3	4.53
	48.2	46.22	21.1	5.84	19.91	5.43	18.73	5.04	18.08	4.84	17.49	4.65	16.3	4.27
	51.8	49.64	21.1	5.49	19.91	5.11	18.73	4.74	18.08	4.56	17.49	4.38	16.3	4.03
	55.4	53.24	21.1	5.15	19.91	4.79	18.73	4.45	18.08	4.29	17.49	4.12	16.3	3.8
	59	56.66	21.1	4.57	19.91	4.52	18.73	4.21	18.08	4.05	17.49	3.9	16.3	3.59

**MDV-V160W/DVN1**  
**Heating**

Combination (%) (Capacity index)	Outdoor Air temperature(°F)		Indoor temperature(°F WB)											
			60.8		64.4		68		69.8		71.6		75.2	
	°F DB	°F WB	TC	PI	TC	PI	TC	PI	TC	PI	TC	PI	TC	PI
		kW	kW	kW	kW	kW	kW	kW	kW	kW	kW	kW	kW	kW
100%	7.34	5	11.93	4.65	11.87	4.81	11.82	4.98	11.82	5.07	11.82	5.15	11.77	5.31
	10.76	8.6	12.41	4.78	12.41	4.94	12.36	5.1	12.36	5.18	12.36	5.26	12.3	5.42
	14.36	12.2	13.01	4.91	12.95	5.07	12.95	5.22	12.95	5.3	12.9	5.37	12.9	5.52
	14.9	14	13.33	4.98	13.28	5.13	13.28	5.28	13.22	5.35	13.22	5.43	13.17	5.58
	16.7	15.62	13.6	5.04	13.55	5.18	13.55	5.33	13.55	5.4	13.49	5.48	13.49	5.62
	19.4	18.32	14.09	5.14	14.09	5.28	14.03	5.41	14.03	5.49	14.03	5.56	13.98	5.7
	23	21.92	14.84	5.27	14.79	5.4	14.79	5.53	14.73	5.59	14.73	5.66	14.68	5.8
	26.6	25.34	15.54	5.38	15.54	4.89	15.49	5.64	15.49	5.7	15.49	5.76	14.84	5.52
	32	30.74	16.78	5.56	16.78	5.67	16.73	5.79	16.46	5.7	15.92	5.46	14.84	5.01
	37.4	35.96	18.13	5.72	18.08	5.82	17	5.39	16.46	5.18	15.92	4.97	14.84	4.57
	41	39.38	19.05	5.82	18.08	5.47	17	5.07	16.46	4.87	15.92	4.68	14.84	4.31
	44.6	42.8	19.16	5.53	18.08	5.14	17	4.77	16.46	4.59	15.92	4.41	14.84	4.06
	48.2	46.22	19.16	5.19	18.08	4.84	17	4.49	16.46	4.27	15.92	4.16	14.84	3.83
	51.8	49.64	19.16	4.89	18.08	4.56	17	4.24	16.46	4.08	15.92	3.92	14.84	3.62
	55.4	53.24	19.16	4.59	18.08	4.29	17	3.99	16.46	3.84	15.92	3.7	14.84	3.41
	59	56.66	19.16	4.33	18.08	4.05	17	3.77	16.46	3.63	15.92	3.49	14.84	3.23
90%	7.34	5	11.85	4.94	11.8	5.09	11.8	5.24	11.74	5.31	11.74	5.39	11.74	5.54
	10.76	8.6	12.34	5.06	12.34	5.2	12.28	5.35	12.28	5.42	12.28	5.49	12.23	5.63
	14.36	12.2	12.93	5.18	12.93	5.32	12.87	5.45	12.87	5.52	12.87	5.59	12.82	5.73
	14.9	14	13.25	5.24	13.2	5.38	13.2	5.51	13.15	5.58	13.15	5.64	13.15	5.77
	16.7	15.62	13.52	5.3	13.52	5.43	13.47	5.56	13.47	5.62	13.47	5.69	13.31	5.74
	19.4	18.32	14.01	5.38	14.01	5.51	13.95	5.64	13.95	5.7	13.95	5.76	13.31	5.48
	23	21.92	14.76	5.5	14.71	5.62	14.71	5.74	14.65	5.8	14.28	5.62	13.31	5.15
	26.6	25.34	15.46	5.61	15.46	5.72	15.3	5.74	14.76	5.51	14.28	5.29	13.31	4.86
	32	30.74	16.76	5.77	16.27	5.62	15.3	5.21	14.76	5.01	14.28	4.81	13.31	4.42
	37.4	35.96	17.24	5.49	16.27	5.12	15.3	4.75	14.76	4.57	14.28	4.39	13.31	4.04
	41	39.38	17.24	5.17	16.27	4.81	15.3	4.47	14.76	4.3	14.28	4.14	13.31	3.81
	44.6	42.8	17.24	4.86	16.27	4.53	15.3	4.21	14.76	4.06	14.28	3.9	13.31	3.6
	48.2	46.22	17.24	4.58	16.27	4.27	15.3	3.97	14.76	3.83	14.28	3.69	13.31	3.4
	51.8	49.64	17.24	4.31	16.27	4.03	15.3	3.75	14.76	3.62	14.28	3.48	13.31	3.22
	55.4	53.24	17.24	4.06	16.27	3.8	15.3	3.54	14.76	3.41	14.28	3.29	13.31	3.04
	59	56.66	17.24	3.83	16.27	3.59	15.3	3.35	14.76	3.23	14.28	3.12	13.31	2.89
80%	7.34	5	11.82	5.23	11.77	5.36	11.77	5.5	11.77	5.56	11.71	5.63	11.71	5.77
	10.76	8.6	12.31	5.34	12.31	5.47	12.25	5.59	12.25	5.66	12.25	5.72	11.87	5.57
	14.36	12.2	12.9	5.45	12.9	5.57	12.84	5.69	12.84	5.75	12.74	5.74	11.87	5.26
	14.9	14	13.22	5.5	13.17	5.62	13.17	5.74	13.17	5.8	12.74	5.57	11.87	5.1
	16.7	15.62	13.49	5.55	12.54	5.67	13.44	5.78	13.17	5.65	12.74	5.42	11.87	4.97
	19.4	18.32	13.98	5.63	13.98	5.74	13.6	5.62	13.17	5.4	12.74	5.18	11.87	4.75
	23	21.92	14.73	5.73	14.46	5.7	13.6	5.28	13.17	5.07	12.74	4.87	11.87	4.47
	26.6	25.34	15.33	5.76	14.46	5.36	13.6	4.97	13.17	4.78	12.74	4.59	11.87	4.22
	32	30.74	15.33	5.23	14.46	4.87	13.6	4.52	13.17	4.35	12.74	4.18	11.87	3.85
	37.4	35.96	15.33	4.76	14.46	4.44	13.6	4.13	13.17	3.98	12.74	3.83	11.87	3.53
	41	39.38	15.33	4.49	14.46	4.19	13.6	3.9	13.17	3.75	12.74	3.62	11.87	3.34
	44.6	42.8	15.33	4.22	14.46	3.95	13.6	3.68	13.17	3.55	12.74	3.42	11.87	3.16
	48.2	46.22	15.33	3.99	14.46	3.73	13.6	3.47	13.17	3.35	12.74	3.23	11.87	2.99
	51.8	49.64	15.33	3.77	14.46	3.52	13.6	3.29	13.17	3.17	12.74	3.06	11.87	2.84
	55.4	53.24	15.33	3.55	14.46	3.33	13.6	3.11	13.17	3	12.74	2.89	11.87	2.68
	59	56.66	15.33	3.36	14.46	3.15	13.6	2.95	13.17	2.84	12.74	2.74	11.87	2.55

**MDV-V160W/DVN1**  
**Heating**

Combination (%) (Capacity index)	Outdoor Air temperature(°F)		Indoor temperature(°F WB)											
			60.8		64.4		68		69.8		71.6		75.2	
	°F DB	°F WB	TC	PI	TC	PI	TC	PI	TC	PI	TC	PI	TC	PI
70%	7.34	5	11.74	5.53	11.68	5.64	11.68	5.76	11.47	5.67	11.09	5.44	10.34	4.99
	10.76	8.6	12.22	5.62	12.22	5.73	11.9	5.59	11.47	5.38	11.09	5.16	10.34	4.73
	14.36	12.2	12.82	5.71	12.65	5.71	11.9	5.28	11.47	5.08	11.09	4.88	10.34	4.48
	14.9	14	13.14	5.76	12.65	5.54	11.9	5.13	11.47	4.93	11.09	4.74	10.34	4.35
	16.7	15.62	13.41	5.79	12.65	5.39	11.9	4.99	11.47	4.8	11.09	4.61	10.34	4.24
	19.4	18.32	13.41	5.53	12.65	5.15	11.9	4.78	11.47	4.6	11.09	4.42	10.34	4.06
	23	21.92	13.41	5.2	12.65	4.84	11.9	4.5	11.47	4.32	11.09	5.11	10.34	3.83
	26.6	25.34	13.41	4.89	12.65	4.57	11.9	4.24	11.47	4.08	11.09	3.93	10.34	3.62
	32	30.74	13.41	4.45	12.65	4.16	11.9	3.87	11.47	3.73	11.09	3.59	10.34	3.32
	37.4	35.96	13.41	4.07	12.65	3.81	11.9	3.55	11.47	3.42	11.09	3.3	10.34	3.05
	41	39.38	13.41	3.84	12.65	3.59	11.9	3.36	11.47	3.23	11.09	3.12	10.34	2.89
	44.6	42.8	13.41	3.63	12.65	3.4	11.9	3.17	11.47	3.06	11.09	2.95	10.34	2.74
	48.2	46.22	13.41	3.43	12.65	3.22	11.9	3	11.47	2.9	11.09	2.8	10.34	2.6
	51.8	49.64	13.41	3.25	12.65	3.04	11.9	2.85	11.47	2.75	11.09	2.66	10.34	2.47
	55.4	53.24	13.41	3.07	12.65	2.88	11.9	2.69	11.47	2.61	11.09	2.52	10.34	2.34
59	56.66	13.41	2.91	12.65	2.73	11.9	2.56	11.47	2.48	11.09	2.39	10.34	2.23	
60%	7.34	5	11.5	5.67	10.85	5.28	10.2	4.89	9.88	4.71	9.55	4.52	8.9	4.16
	10.76	8.6	11.5	5.37	10.85	5	10.2	4.64	9.88	4.47	9.55	4.29	8.9	3.97
	14.36	12.2	11.5	5.07	10.85	4.73	10.2	4.39	9.88	4.22	9.55	4.06	8.9	3.75
	14.9	14	11.5	4.93	10.85	4.6	10.2	4.27	9.88	4.11	9.55	3.95	8.9	3.64
	16.7	15.62	11.5	4.8	10.85	4.48	10.2	4.16	9.88	4.01	9.55	3.85	8.9	3.56
	19.4	18.32	11.5	4.59	10.85	4.29	10.2	3.98	9.88	3.84	9.55	3.69	8.9	3.41
	23	21.92	11.5	4.32	10.85	4.04	10.2	3.76	9.88	3.62	9.55	3.49	8.9	3.23
	26.6	25.34	11.5	4.08	10.85	3.82	10.2	3.56	9.88	3.43	9.55	3.3	8.9	3.05
	32	30.74	11.5	3.73	10.85	3.49	10.2	3.26	9.88	3.15	9.55	3.03	8.9	2.81
	37.4	35.96	11.5	3.42	10.85	3.21	10.2	3	9.88	2.89	9.55	2.79	8.9	2.59
	41	39.38	11.5	3.23	10.85	3.04	10.2	2.84	9.88	2.74	9.55	2.65	8.9	2.46
	44.6	42.8	11.5	3.06	10.85	2.87	10.2	2.69	9.88	2.6	9.55	2.51	8.9	2.34
	48.2	46.22	11.5	2.9	10.85	2.73	10.2	2.55	9.88	2.47	9.55	2.38	8.9	2.22
	51.8	49.64	11.5	2.75	10.85	2.59	10.2	2.43	9.88	2.35	9.55	2.27	8.9	2.12
	55.4	53.24	11.5	2.6	10.85	2.45	10.2	2.3	9.88	2.23	9.55	2.16	8.9	2.01
59	56.66	11.5	2.48	10.85	2.33	10.2	2.19	9.88	2.12	9.55	2.06	8.9	1.92	
50%	7.34	5	9.58	4.55	9.04	4.24	8.5	3.95	8.18	3.8	7.91	3.66	7.37	3.38
	10.76	8.6	9.58	4.32	9.04	4.03	8.5	3.75	8.18	3.62	7.91	3.48	7.37	3.22
	14.36	12.2	9.58	4.09	9.04	3.82	8.5	3.56	8.18	3.43	7.91	3.31	7.37	3.06
	14.9	14	9.58	3.98	9.04	3.72	8.5	3.47	8.18	3.34	7.91	3.22	7.37	2.98
	16.7	15.62	9.58	3.88	9.04	3.63	8.5	3.38	8.18	3.26	7.91	3.15	7.37	2.91
	19.4	18.32	9.58	3.72	9.04	3.48	8.5	3.25	8.18	3.13	7.91	3.02	7.37	2.8
	23	21.92	9.58	3.51	9.04	3.29	8.5	3.07	8.18	2.97	7.91	2.86	7.37	2.65
	26.6	25.34	9.58	3.32	9.04	3.12	8.5	2.91	8.18	2.81	7.91	2.71	7.37	2.52
	32	30.74	9.58	3.05	9.04	2.86	8.5	2.68	8.18	2.59	7.91	2.5	7.37	2.33
	37.4	35.96	9.58	2.81	9.04	2.64	8.5	2.47	8.18	2.39	7.91	2.31	7.37	2.16
	41	39.38	9.58	2.66	9.04	2.5	8.5	2.35	8.18	2.27	7.91	2.2	7.37	2.05
	44.6	42.8	9.58	2.53	9.04	2.38	8.5	2.24	8.18	2.16	7.91	2.09	7.37	1.96
	48.2	46.22	9.58	2.4	9.04	2.26	8.5	2.12	8.18	2.06	7.91	1.99	7.37	1.86
	51.8	49.64	9.58	2.28	9.04	2.15	8.5	2.03	8.18	1.96	7.91	1.9	7.37	1.78
	55.4	53.24	9.58	2.17	9.04	2.04	8.5	1.93	8.18	1.87	7.91	1.81	7.37	1.7
59	56.66	9.58	2.06	9.04	1.95	8.5	1.84	8.18	1.78	7.91	1.73	7.37	1.62	

Note:

1. [shaded] is tested under our standard condition.
2. Avoid to run the unit when the temperature is below 5°F (-15°C).
3. The above table shows the average value of conditions may operate.
4. It is recommended to connect less than 130%.

### 8. Electric Characteristics

Model	Outdoor Unit				Power Supply			Compressor		OFM	
	Hz	Voltage	Min.	Max.	MCA	TOCA	MFA	MSC	RLA	kW	FLA
MDV-V105W/DVN1	60	208-230	187	253	27.5	24	32	/	9.7	0.17	1.7
MDV-V120W/DVN1	60	208-230	187	253	31.25	30	40	/	13.5	2x0.1	2x0.9
MDV-V140W/DVN1	60	208-230	187	253	36.25	30	40	/	13.5	2x0.1	2x0.9
MDV-V160W/DVN1	60	208-230	187	253	36.25	30	40	/	16.1	2x0.1	2x0.9

**Remark:**

- TOCA: Total Over-current Amps. (A)
- MFA: Max. Fuse Amps. (A)
- RLA: Rated Locked Amps. (A)
- OFM: Outdoor Fan Motor.
- FLA: Full Load Amps. (A)
- kW: Rated Motor Output (KW)

### 9. Sound Levels

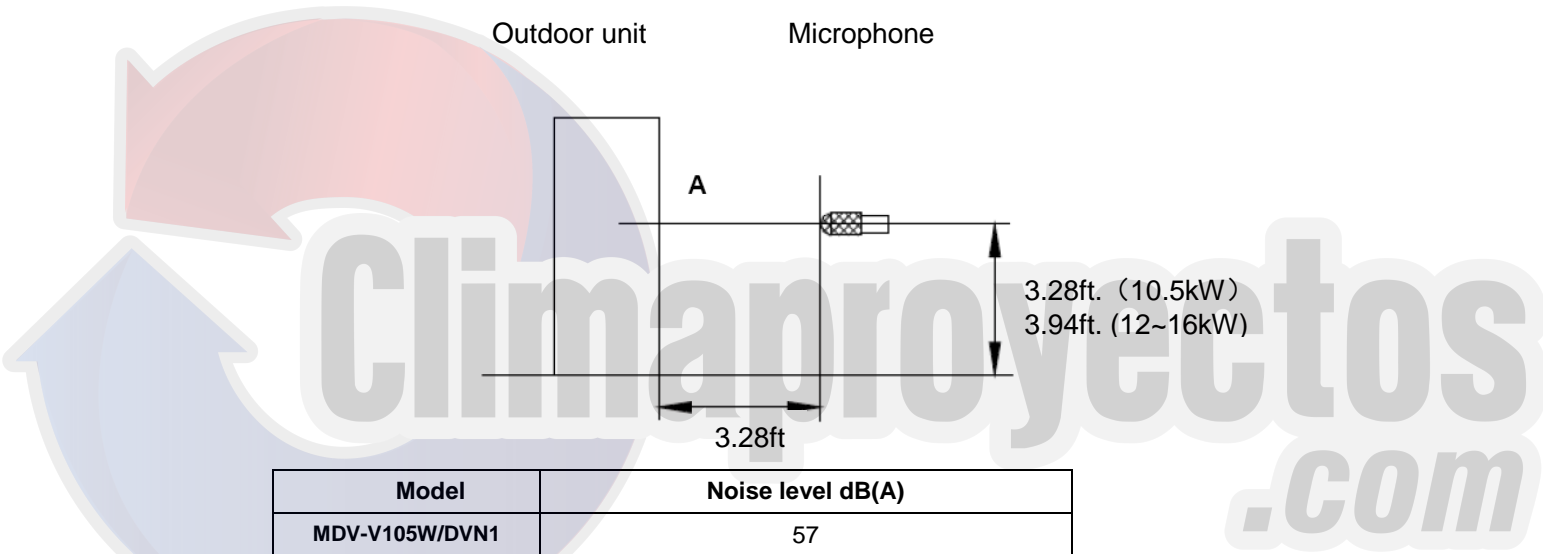

Model	Noise level dB(A)
MDV-V105W/DVN1	57
MDV-V120W/DVN1	57
MDV-V140W/DVN1	57
MDV-V160W/DVN1	57

# 10. Operation Limits

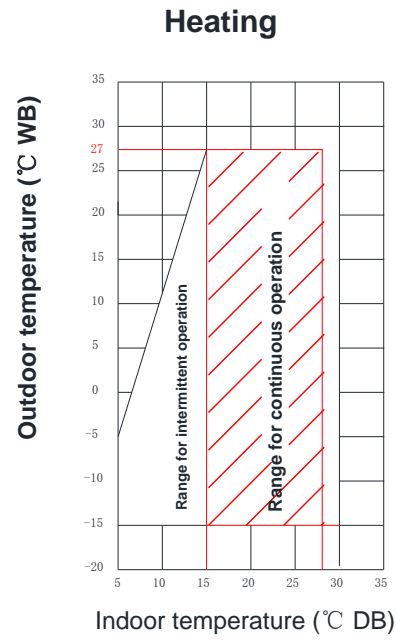
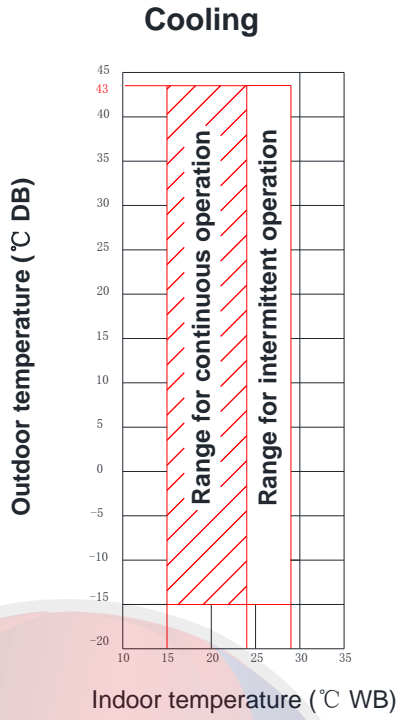

**Note:**

1. These figures assume the following operating conditions:  
Equivalent piping length: 7.5m  
Level difference: 0m
2. If the system is running in cooling mode, when the ambient temperature is lower than -15°C (5°F) or higher than 43°C(109.4 °F), the unit will stop for protection control.

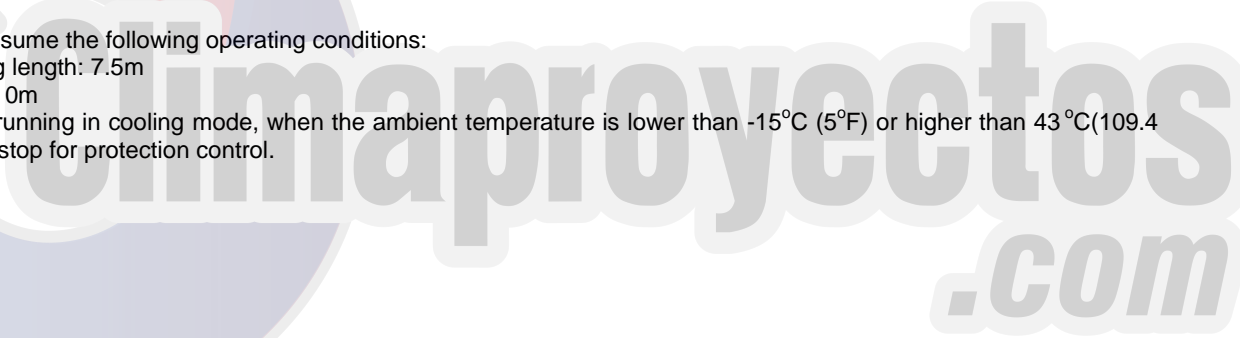

## Part 3 Installation

1. Precautions .....	54
2. Accessories .....	55
3. Outdoor unit installation .....	55
4. Piping installation.....	57
5. Electric Wiring Installations.....	61
6. Outdoor Unit Wiring .....	63
7. Test Running .....	64
8. Precautions on Refrigerant Leakage .....	64



Climaproyectos  
.com

## 1. Precautions

- Ensure that all Local, National and International regulations are satisfied.
- Read this "PRECAUTIONS" carefully before Installation.
- The precautions describe below including the important Items regarding safety.
- Observe them without fail.
- After the installation work, perform a trial operation to check for any problem.
- Follow the Owner's Manual to explain how to use and maintain the unit to the customer.
- Turn off the main power supply switch (or breaker) before maintain the unit.
- Tell the customer that the Installation Manual and the Owner's manual should be kept together.

### Caution 1:

The characteristics of R410A refrigerant are Hydrophilic, oxidizing membrane or oil, and its pressure is approx.1.6 times higher than that of refrigerant R22. Accompanied with the new refrigerant, refrigerating oil has also been changed, Therefore, during installation work, be sure that water, dust, former refrigerant, or refrigerating oil does not enter the refrigerating cycle.

To prevent charging an incorrect refrigerant and refrigerating oil, the sizes of connecting sections of charging port of the main unit and installation tools are charged from those for the conventional refrigerant.

Accordingly the exclusive tools are required for the new refrigerant (R410A).

For connecting pipes, use new and clean piping designed for R410A, and please care so that water or dust does not enter.

Moreover, do not use the existing piping because there are problems with pressure-resistance force and impurity in it.

### Caution 2:

This unit must be connected to the main power supply by means of a switch with a contact separation of at least 3 mm. The installation fuse must be used for the power supply line of this conditioner.

### Caution 3:

Ask an authorized dealer or qualified installation professional to install/maintain the air conditioner. Inappropriate installation may result in water leakage, electric shock or fire.

Turn off the main power supply switch or breaker before attempting any electrical work. Make sure all power switches are off.

Failure to do so may cause electric shock.

Connect the connecting cable correctly. If the connecting cable is connected in a wrong way, electric parts may be damaged.

When moving the air conditioner for the installation into another place, be very careful not to enter any gaseous matter other than the specified refrigerant into the refrigeration cycle. If air or any other has is mixed in refrigerant, the gas pressure in the refrigeration cycle becomes abnormally high and it may resultantly causes pipe burst and injuries on persons.

Do not modify this unit by removing any of the safety guards or by by-passing any of the safety inter lock switches. Exposure of unit to water or other moisture before installation may cause a short circuit of electrical parts.

Do not store it in a wet basement or expose to rain or water. After unpacking the unit, examine it carefully if there are possible damage.

Do not install in a place that might increase the vibration of the unit. To avoid personal injury (with sharp edges) be careful when handling parts.

Perform installation work properly according to the Installation Manual. Inappropriate installation may result in water leakage, electric shock or fire. When the air conditioner is installed in a small room, provide appropriate measures to ensure that the concentration of refrigerant leakage occur in the room does not exceed the critical level. If refrigerant gas has leaked during the installation work, ventilate the room immediately. If the leaked refrigerant gas comes in contact with fire, noxious gas may generate. After the installation work, confirm that refrigerant gas doer not leak. If refrigerant gas leaks into the room and flows near a fire source, such as a cooking range, noxious gas might generate.

Install the air conditioner securely in a location where the base can sustain the weight adequately. Perform the specified installation work to guard against an earthquake. If the air conditioner is not installed appropriately, accidents may occur due to the falling unit.

Electrical work must be performed by a qualified electrician in accordance with the Installation Manual. Make sure the air conditioner uses an exclusive power supply. An insufficient power supply capacity or inappropriate installation may cause fire.





Use the specified cables for wiring connect the terminals securely fix. To prevent external forces applied to the terminals from affecting the terminals. Be sure to provide grounding. Do not connect ground wires to gas pipes, water pipes, lightning rods or ground wires for telephone cables. Conform to the regulations of the local electric company when wiring the power supply.

Inappropriate grounding may cause electric shock Do not install the air conditioner in a location subject to a risk of exposure to a combustible gas. If a combustible gas leaks, and stays around the unit, a fire may occur.



## 2. Accessories

Please check whether the following fittings are of full scope. If there are some spare fittings, please restore them carefully.

	NAME	SHAPE	QUANTITY
INSTALLATION FITTINGS	1. Outdoor unit installation manual		1
	2. Outdoor unit owner's manual		1
	3. Indoor unit owner's manual		1
	4. Outflow connecting tube		1

## 3. Outdoor unit installation

### 3.1 Installation space selection

- Install the outdoor unit at a place where discharge air is not blocked. When an outdoor unit is installed in a place that is always exposed
- To a strong wind like a coast or on the high store of a building, secure a normal fan operation by using a duct or a wind shield.
- When installing the outdoor unit in a place that is constantly exposed to a strong wind such as the upper stairs or rooftop of a building, apply the windproof measures referring to the following examples.
- Install the unit so that its discharge port faces to the wall of the building. Keep a distance 2000mm (78.7 inch) or more between the unit and the wall surface.
- Supposing the wind direction during the operation season of the discharge port is set at right angle to the wind direction.

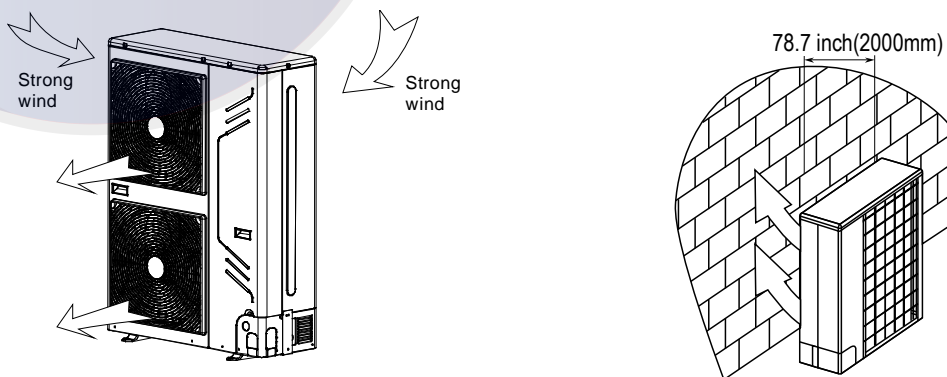

- Do not install the unit in a place full of machine oil.
- Do not install the unit in a place full of sulphuric gas.
- Do not install the unit in a place where high-frequency radio waves are likely to be.

### 3.2 Installation space (units: mm)

- Since the gravity center of the unit is not at its physical center, so please be careful when lifting it with a sling.
- Never hold the inlet of the outdoor unit to prevent it from deforming.
- Do not touch the fan with hands or other objects.
- Do not lean it more than 45°, and do not lay it sidelong.

- Make concrete foundation according to the specifications of the outdoor units.
- Fasten the feet of this unit with bolts firmly to prevent it from collapsing in case of earthquake or strong wind.

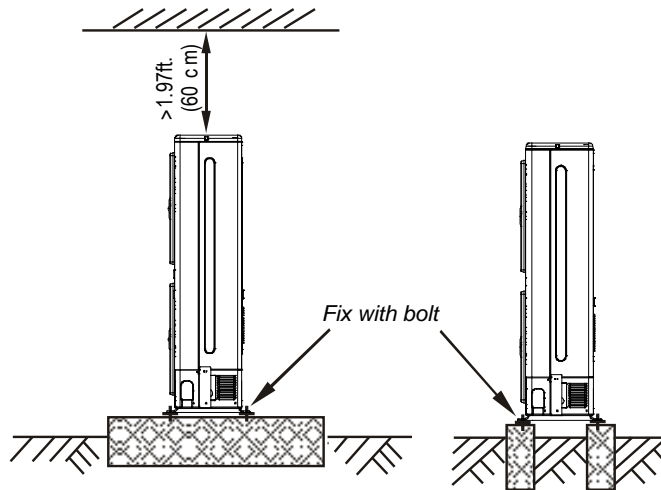

**Single unit installation**

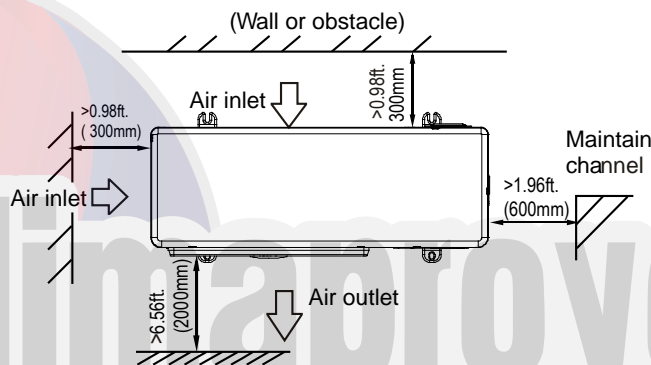

**Parallel connect two units or above**

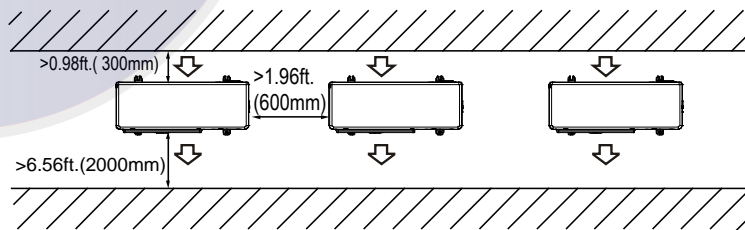

**Parallel connect the front with rear sides**

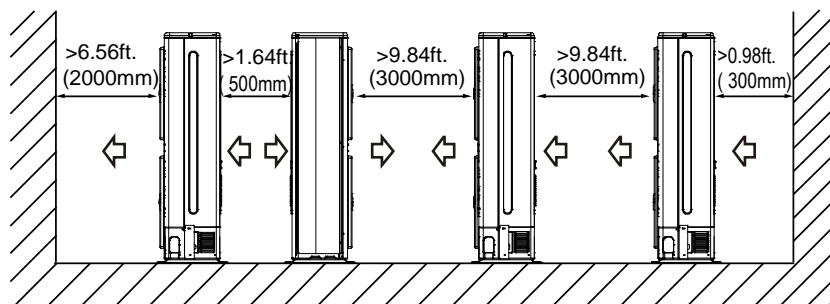

All the pictures in this manual are for explanation purpose only. They may be slightly different from the air conditioner you purchased (depend on model).The actual shape shall prevail.

### 3.3 Water Outlet

Four condensed water outlets on the chassis for selection display as the follow figure:

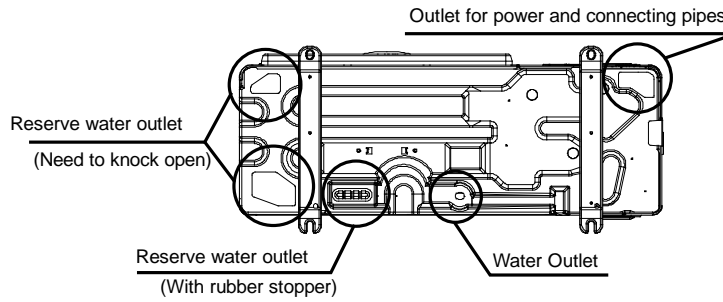

While installing the outdoor unit, pay attention to the installation place and the drainage pattern; if it's installed at the alpine zone, the frozen condensed water will block up the water outlet, please pull out the rubber stopper of the reserve water outlet. If that still fails to satisfy for the water draining, please knock open the other two water outlets, and keep the water can drain in time. Pay attention to the knock the reserve water outlet from outside to inside, and it will be beyond repair after knocking open, please pay attention to the installation place, lest cause the inconvenience. Please do the moth proofing for the knocked out hole, to avoid the pest processing into and destroy the components.

## 4. Piping installation

### 4.1 Piping connection

Offering four directions to connect pipes and wirings for meet a variety of installation requests.

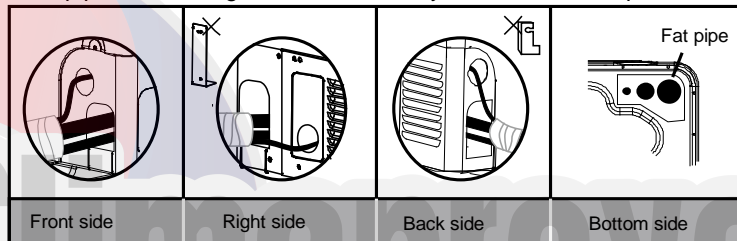

Right side pipe connection: please remove the L-shape metal plate, otherwise cannot wiring.

Back side pipe connection: please wipe off the piping support rubber blanket beside the inner outlet pipe cover of the machine while back side getting out pipes.

Bottom side pipe connection: the knock out should from inside to outside, and then piping and wiring through this.

Pay attention to the piping the fat connecting pipe should out from the largest hole, otherwise the pipes will be rubbed. Please do the moth proofing for the knocked out hole, to avoid the pest processing into and destroy the components.

### 4.2 Allowable length and level difference of refrigerant pipe

		Permitted value	Piping	
Pipe Length	Total Pipe Length(Actual)	≤382ft.(100m)	L1+L2+L3+L4+L5+a+b+c+d+e+f	
	Maximum Piping(L)	Actual Length	L1+L2+L3+L4+L5+f(The first connecting method) or L1+L3+L5+f(The second connecting method)	
		Equivalent Length		≤147.6ft. (10.5kW)
	≤196.9ft.(60m) (12~16kW)			
	≤164ft.(50m) (10.5kW)			
	≤229.7ft.(70m) (12~16kW)			
	Pipe Length (from the first branch to the furthest IDU)	≤65.6ft.(20m)	L2+L3+L4+L5+f(The first connecting method) or L3+L5+f(The second connecting method)	
	Pipe Length(IDU to the nearest branch)	≤49.2ft.(15m)	a,b,c,d,e	
Level difference	Level difference between IDU~ODU	Outdoor Unit up	≤98.4ft.(30m)	-----
		Outdoor Unit Down	≤65.6ft.(20m)	-----
		Level difference between IDU~IDU	≤26.2ft.(8m)	-----

Note: When the total equivalent piping length of liquid + gas side is ≥295.3ft. (90m), it must increase the size of air side main pipe. Besides, according to the distance of refrigerant pipe and the over matched state of indoor unit, when the capacity is decreasing it still can increase the gas side main pipe size.

**The first connecting method**

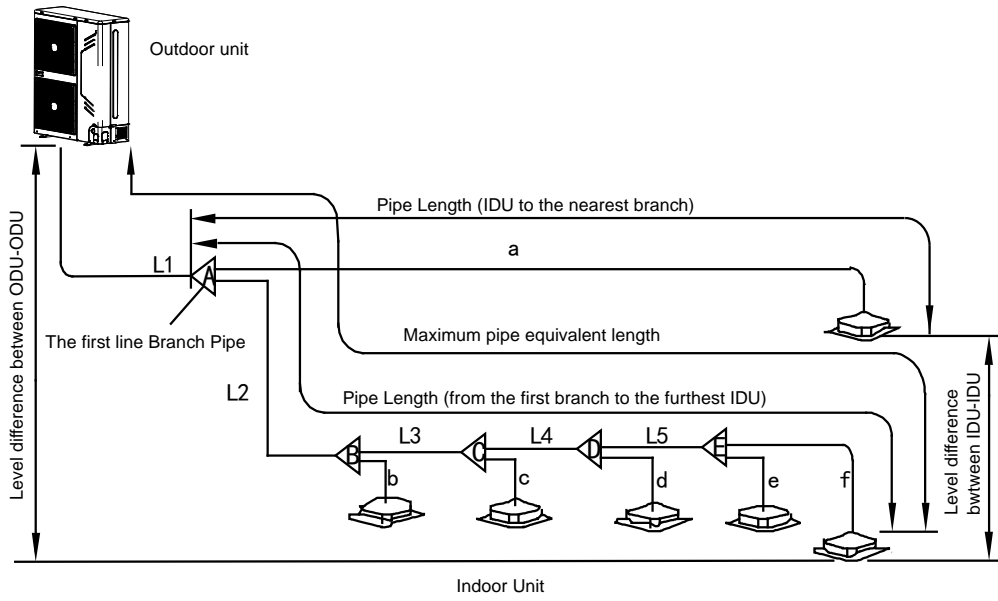

**The second connecting method**

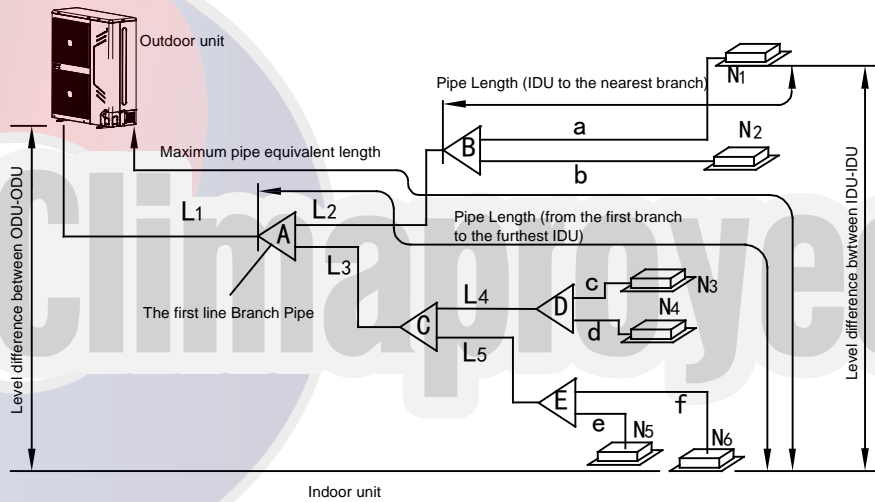

**4.3 Refrigerant pipe selection**

**The first connecting method**

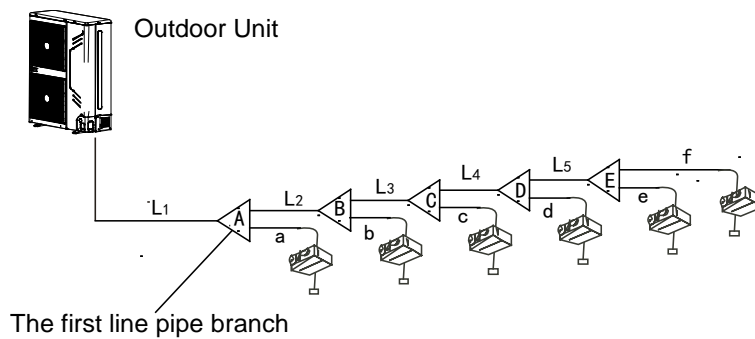

**The second connecting method**

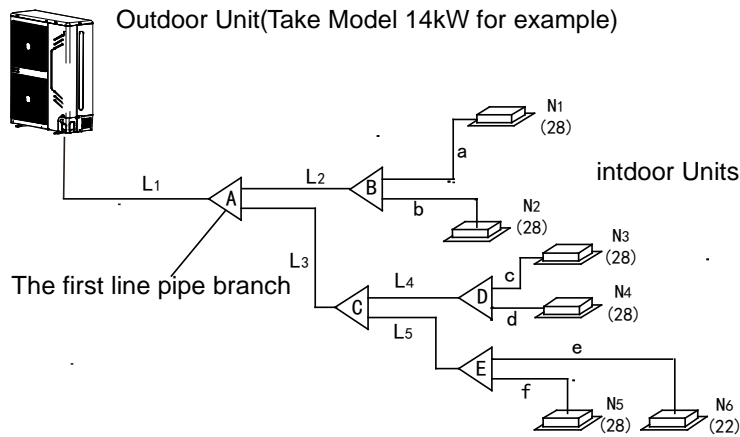

Pipe definition	Pipe connecting position	Code
Main pipe	The pipe between outdoor units to the first branch of indoor unit.	L1
The main pipes of indoor unit	The pipe after the first branch does not direct connect with the indoor unit.	L2~L5
The branch pipes of indoor unit	The pipe after the branch connects with the indoor unit.	a,b,c,d,e,f
Indoor unit branch pipes components	The pipes connect with the main pipe, the branch pipe and the main pipe of indoor unit.	A,B,C,D,E

Note: The distance between the first branch to the last indoor unit is more than 65.6ft. (20m), choose the second connecting method. The pipe between the indoor units to the closest branch must be less than 49.2ft. (15m).

**Table 1: Indoor unit branch pipes selection (a~f)**

A: Capacity of indoor units (kW)

A (kW)	Gas Side(Φ)	Liquid Side(Φ)
Wall mounted 1.5~4.5	1/2in.(12.7mm)(Flaring nut)	1/4in.(6.35mm)(Flaring nut)
Wall mounted 5.6	5/8in.(15.9mm)(Flaring nut)	3/8in.(9.53mm)(Flaring nut)
Four way cassette type 7.1~16	5/8in.(15.9mm)(Flaring nut)	3/8in.(9.53mm)(Flaring nut)
Four way cassette compact type 2.2~4.5	1/2in.(12.7mm)(Flaring nut)	1/4in.(6.35mm)(Flaring nut)
Four way cassette compact type 5.6	5/8in.(15.9mm)(Flaring nut)	3/8in.(9.53mm)(Flaring nut)
Duct type 2.2~4.5	1/2in.(12.7mm)(Flaring nut)	1/4in.(6.35mm)(Flaring nut)
Duct type 5.6~14	5/8in.(15.9mm)(Flaring nut)	3/8in.(9.53mm)(Flaring nut)
Ceiling & Floor 3.6~4.5	1/2in.(12.7mm)(Flaring nut)	1/4in.(6.35mm)(Flaring nut)
Ceiling & Floor 5.6~16	5/8in.(15.9mm)(Flaring nut)	3/8in.(9.53mm)(Flaring nut)

Note: The maximum length of the branch pipe should not be longer than 50ft. (15m).

**Table 2: Indoor unit main pipes selection (L1~L5)**

Total capacity of downstream indoor units (kW)	Main pipe size(mm)		Branch Pipe
	Air pipe	Liquid pipe	
A < 16.6	Φ5/8(Φ15.9)	Φ3/8(Φ9.53)	FQZHN-01D
16.6 ≤ A < 23	Φ3/4(Φ19.1)	Φ3/8(Φ9.53)	FQZHN-01D

**Table 3: Main pipes selection (L1)**

Total capacity of outdoor units (kW)	When the equivalent length of all liquid and air pipes < 90m			When the equivalent length of all liquid and air pipes ≥ 90m		
	gas side (mm)	liquid side (mm)	The first line branch pipe	gas side (mm)	liquid side (mm)	The first line branch pipe
A < 16	Φ5/8(Φ15.9)	Φ3/8(Φ9.53)	FQZHN-01D	Φ3/4(Φ19.1)	Φ3/8(Φ9.53)	FQZHN-01D
16 ≤ A < 23	Φ3/4(Φ19.1)	Φ3/8(Φ9.53)	FQZHN-01D	Φ7/8(Φ22.2)	Φ3/8(Φ9.53)	FQZHN-02D

Note: Main pipe L1 can be selected from table 2 and table 3, the larger size should be finally selected.

The straight distance between copper pipe turning and the contiguous branch pipe is at least 1.6ft.(0.5m);

The straight distance between the contiguous branch pipes is at least 1.6ft.(0.5m);

The straight distance which the branch pipes connected to the indoor unit is at least 1.6ft.(0.5m);

**Table4: Outdoor unit pipe connection**

MODEL	Piping side	Outdoor unit pipe connection (mm)	
		Gas Side	Liquid Side
10.5kW		Φ5/8(Φ15.9)	Φ3/8(Φ9.53)
12kW		Φ5/8(Φ15.9)	Φ3/8(Φ9.53)
14kW		Φ5/8(Φ15.9)	Φ3/8(Φ9.53)
16kW		Φ3/4(Φ19.1)	Φ3/8(Φ9.53)

Outdoor Unit (kW)	Maximum Quantity of Indoor unit	Total Capacity of Indoor unit
10.5	5	45%~130%
12	6	45%~130%
14	6	45%~130%
16	7	45%~130%

If ODU connect only one IDU, the capacity of IDU should be not more than ODU.

If ODU connect more than one IDU, the capacity of each IDU should be not more than 8kW for refrigerant uniform distribution.

When capacity of indoor unit greater than the sum of 100%, capacity of indoor unit will be attenuated.

When capacity of indoor unit greater than or equal to the sum of 120%, in order to ensure the effectiveness of machine, and then try to open the indoor units at different time.

When the capacity of indoor unit is greater than or equal to 16.8kW, the caliber of primary gas pipe should be augmented from Φ16 toΦ19.

#### 4.4 Remove Dirt or Water in the Piping

Make sure there is no any dirt or water before connecting the piping to the outdoor units.

Wash the piping with high pressure nitrogen, never use refrigerant of outdoor unit.

#### 4.5 Airtight Test

Charge pressured nitrogen after connecting indoor/outdoor unit piping to do airtight test.

Cautions:

1. Pressured nitrogen [4.3MPa (44kg/cm<sup>3</sup>) for R410A] should be used in the airtight test.
2. Tighten high pressure/low pressure valves before applying pressured nitrogen.
3. Apply pressure from air vent mouth on the high pressure/low pressure valves.
4. The high pressure/low pressure valves are closed when applying pressured nitrogen.
5. The airtight test should never be used any oxygen, flammable gas or poisonous gas.

#### 4.6 Vacuum

Using vacuum pump to do the vacuum and never using refrigerant to expel the air.

Vacuum should be done from both liquid side and gas side simultaneously.

#### 4.7 Additional refrigerant charge

Calculate the added refrigerant according to the diameter and the length of the liquid side pipe of the outdoor unit/indoor unit connection.

When the outdoor unit connects one indoor unit:

Liquid Side Piping Diameter	Refrigerant to be Added Perimeter Piping
Φ1/4(Φ6.35)	0.05lbs.(0.023kg)
Φ3/8(Φ9.53)	0.13lbs.(0.060kg)
Φ1/2(Φ12.7)	0.26lbs(0.120kg)
Φ5/8(Φ15.9)	0.39lbs(0.180kg)
Φ3/4(Φ19.1)	0.59lbs(0.270kg)
Φ7/8(Φ22.2)	0.84lbs(0.380kg)

Note: Additional refrigerant volume of divergent pipe is 0.1kg per item (Consider the liquid side of branch pipe only).

## 4.8 Leak detection

Use soap water or leak detector to check every joint whether leaks or not.

Note: A is low pressure side stop valve.

B is high pressure side stop valve.

C and D are connecting pipes interface of indoor and outdoor units.

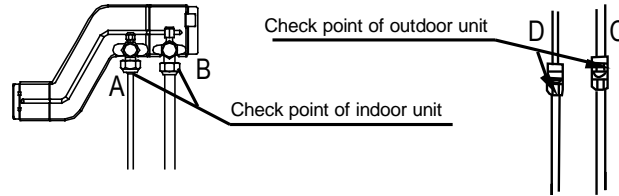

## 4.9 Heat Insulation

Do the heat insulation to the pipes of air side and liquid side separately. The temperature of the pipes of air side and liquid side when cooling, for avoiding condensation please do the heat insulation fully.

- The air side pipe should use closed cell foamed insulation material, which the fire-retardant is B1 grade and the heat resistance over 120°C.
- When the external diameter of copper pipe  $\leq \Phi 12.7\text{mm}$ , the thickness of the insulating layer at least more than 5ft.(15mm); When the external diameter of copper pipe  $\geq \Phi 5/8(15.9\text{mm})$ , the thickness of the insulating layer at least more than 6.56ft.( 20mm).
- Please use attached heat-insulating materials to do the heat insulation without clearance for the connecting parts of the indoor unit pipes.

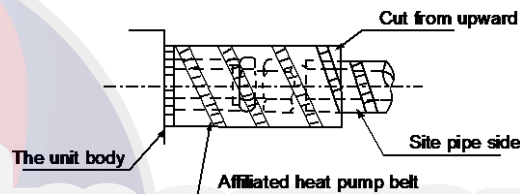

## 5. Electric Wiring Installations

### 5.1 Highlights of electrical installation

- 1) Please separately design the special power of indoor units and outdoor units.
- 2) The power adopts special circuit, and installs creepage protector and manual switch.
- 3) The indoor units' power, creepage protector and manual switch connecting to the same outdoor unit must be general. All indoor units must be the same circuit, and must simultaneously on or off; otherwise, system life will seriously effect, and appear the situation not to solve.
- 4) The communication line between indoor units and outdoor units please use 3 core shielded wiring, while don't use the multi core wiring without shielded affect, for the interference is reduced each other
- 5) Purchased wiring, parts and materials should be in compliance with the local and national regulations.
- 6) All field wiring construction should be finished by qualified electrician.
- 7) Air conditioning equipment should be grounded according to the relevant local and national electrical regulations.
- 8) Current leakage protection switch should be installed (select current leakage breaker in light of the 1.5-2 times of total loading rated current.)
- 9) When connecting wiring and wire holder, use cable clamp to fix and make sure no exposure.
- 10) Refrigerant piping system and wiring system of indoor and outdoor unit belongs to the different system.
- 11) Do not connect the power wire to the terminal of signal wire.
- 12) When power wire is parallel with signal wire, put wires to their own wire tube and remain proper gap (the current capacity of power wire is: 10A below 300mm, 50A below 500mm).
- 13) Voltage discrepancy of power wire terminal (side of power transformer) and end voltage (side of unit) should be less than 2%. If its length could not be shortened, thicken the power wire. Voltage discrepancy between phases shall not pass 2% rated value and Current discrepancy between highest and lowest phase should be less than 3% rated value.

**5.2 Selection of wiring**

1. The selection of wiring area shall in accordance with the requirements below:
    - 1) Voltage loss of wire shall meet the requirement of terminal voltage for normal operation and startup.
    - 2) The wiring current-carrying capacity determined by installed method and environment is not less than the largest current of unit.
    - 3) Conductor shall ensure the stability of movement and heating.
    - 4) The conductor’s smallest sectional area should satisfy the requirement of mechanical strength.
- When earth protection line (shortly called PE line) is made of material the same as phase line, the smallest sectional area of PE line should be in accordance with the regulation below:

Sectional area of core to phase lines(mm)	Smallest sectional area of PE line(mm)
$S \leq 16$	S
$16 < S \leq 35$	16
$S > 35$	S/2

**5.3 Distribution highlights of distribution wiring**

1. When distributing wiring, select wirings with different colors for phase line, zero line and protection earth according to relevant regulations.
2. The power wire and control wire of concealed engineering is prohibited to bind together with refrigerant piping. It is necessary to pass through wire tube and be distributed separately, and the gap between control line and power wire should be 500mm at least.
3. When distributing wiring by passing through pipe, the following should be paid attention to:
  - 1) Metal wire tube could be used in indoor and outdoor, but it is not suitable to the place with acid – alkali corrosion.
  - 2) Plastic wire tube is generally used in indoor and place with corrosion, but it is not suitable to situation with mechanical damage.
  - 3) The wiring through pipe shall not be in the form with ends jointing. If there must be joint, connection box should be installed at the corresponding place.
  - 4) The wiring with different voltage should not pass through the same wire tube.
  - 5) Total sectional area of wiring through wire tube shall not exceed 40% valid area of stuffing tube.
  - 6) Fixing point of wire tube support shall follow the standard below:

Normal diameter of wire tube Mm	Largest gap between fixed points of wire tube	
	Metal pipe	Plastic pipe
15~20	4.9ft.(1.5m)	3.3ft.(1m)
25~32	6.6ft.(2m)	4.9ft.(1.5m)
40~50	8.2ft.(2.5m)	6.6ft.(2m)

**5.4 Example connection of wiring**

**5.4.1 Indoor unit power supply wiring**

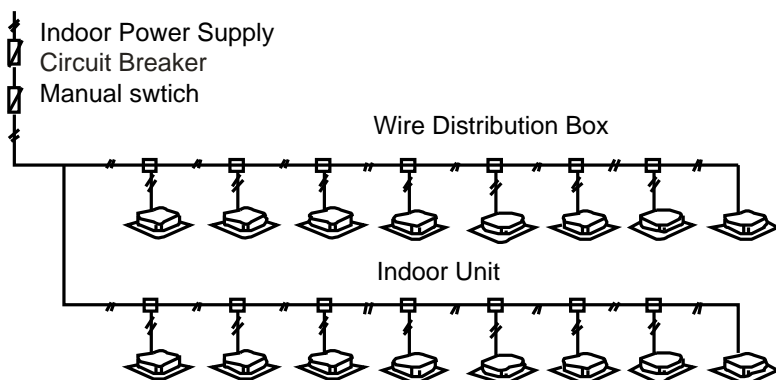



5.4.2 Indoor/Outdoor unit signal wire wiring

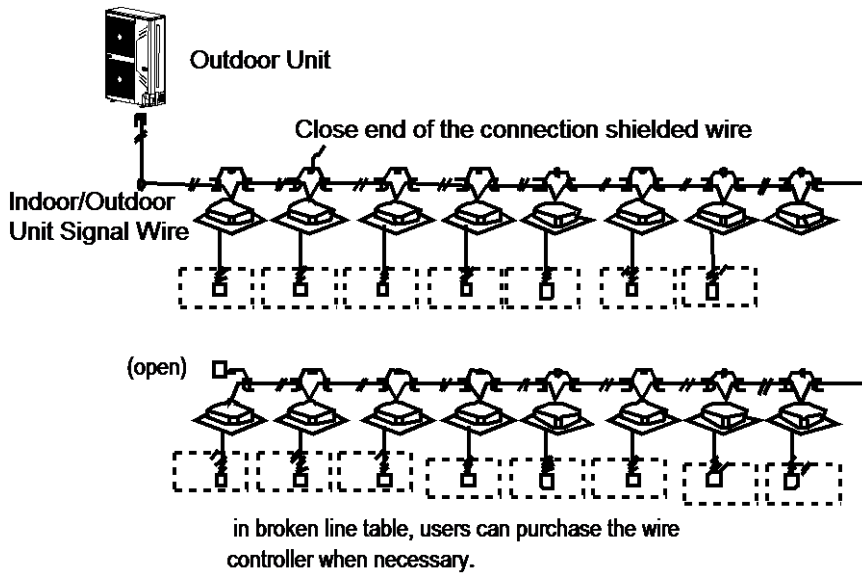

Note:

- 1) Set refrigerant piping system, signal wires between indoor-indoor unit, and that between outdoor-outdoor units into one system.
- 2) Please do not put the signal wire and power wire in the same wire tube; keep distance between the two tubes. (Current capacity of power supply: less than 10A--300mm, less than 50A--500mm.)

6. Outdoor Unit Wiring

The Specification of Power

Table 6-1

Capacity		10.5kW	12-14kW	16kW
Outdoor Unit power	Phase	1 phase	1 phase	1 phase
	Voltage and Frequency	208-230V~ 1Ph 60Hz	208-230V~ 1Ph 60Hz	208-230V~ 1Ph 60Hz
	Power Wiring(mm <sup>2</sup> )	3-core X4.0	3-core X4.0	3-core X4.0
Circuit Breaker/Fuse (A)		30	40	63
Indoor unit/Outdoor unit Signal wire (Weak electric signal) (mm <sup>2</sup> )		3-core shielded wire 3X0.75		

CAUTION

A disconnection device having an air gap contact separation in all active conductors should be incorporated in the fixed wiring according to the National Wiring Regulation.

Caution:

- Employ an electrical engineer for wiring.
- Complete wiring according to national electrical standards.
- To reduce interference, use a three-core shielded twisted pair as the outdoor unit signal cable. Do not use a multi-core cable.
- Incorporate the outdoor unit and indoor unit connection wiring system and refrigerant pipe system for the same system.
- The power supply, electric leakage protectors, and manual switches of the indoor units that connect to the same outdoor unit must be universal. Use the same loop for the indoor unit power. Connect to the same outdoor unit must be universal. Use the same loop for the indoor unit power supplies in the same system. Power on/off at the same time.
- If the power supply uses a branch loop, install an electricity leakage protector and a manual switch.
- Design a dedicated power supply for the indoor unit and outdoor unit.

Indoor/Outdoor Unit Signal Wire

Connect the wire according to their numbers. Wrong connection may cause malfunction.

Wiring Connection

Seal the wiring connection with the insulation material, or the condensing dew will be caused.

**NOTE**

The air-conditioners can connect with Central Control Monitor (CCM). Before operation, please wiring correctly and set system.

**7. Test Running**

Operate according to “key points for test running” on the electric control box cover.

**CAUTION**

- Test running cannot start until the outdoor unit has been connected to the power for 12 hours.
- Test running cannot start until all the valves are affirmed open.
- Never make the test running if the machine has malfunction.
- Make sure the communication between outdoor unit and indoor unit is normal before test running.

**8. Precautions on Refrigerant Leakage**

This air conditioner (A/C) adopts innocuous and nonflammable refrigerant. The locating room of the A/C should big enough that any refrigerant leakage is unable to reach critical thickness. So certain essential action can be taken on time.

**Refrigerant critical thickness: 0.44[kg/m<sup>3</sup>] for R410A.**

Confirm the critical thickness through follow steps, and take necessary actions.

1. Calculate the sum of the charge volume (A[kg]) Total Refrigerant volume of 10HP=factory refrigerant volume + super addition.
2. Calculate the indoor cubage (B[m<sup>3</sup>]) (as the minimum cubage).
3. Calculate the refrigerant thickness.

$$\frac{A[\text{kg}]}{B[\text{m}^3]} \leq \text{critical thickness}$$

Counter measure against over high thickness.

1. Install mechanical ventilator to reduce the refrigerant thickness under critical level. (Ventilate regularly).
2. Install leak alarm facility related to mechanical ventilator if you cannot regularly ventilate.

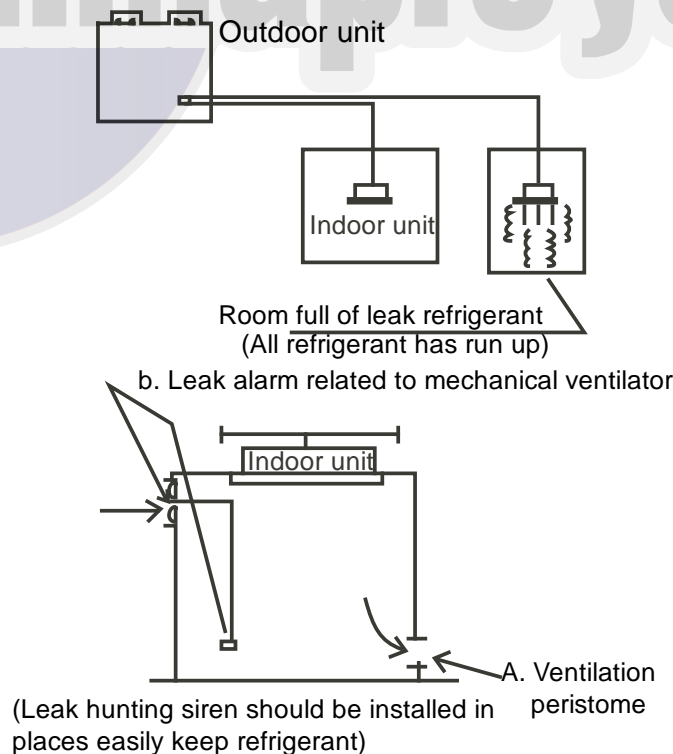

**NOTE**

Please press “constraint cool” button to carry out refrigerant recycling process. Keep the low pressure above 0.2MPa; otherwise compressor may be burnt out.



GD Midea Heating & Ventilating Equipment Co., Ltd.  
Is certified under the ISO 14001 International standard  
for environmental management.  
Certificate No.15912E10020R0L



GD Midea Heating & Ventilating Equipment Co., Ltd.  
Is certified under the ISO 9001 International standard  
for quality assurance.  
NO.01 100 019209



GD Midea Heating & Ventilating Equipment Co., Ltd.  
Certificate of Occupational Health and Safety Management System  
Certificate No. 15912S20006R0L-1.

## Commercial Air Conditioner Division Midea Group

Address: Midea Headquarters Building, 6 Midea Avenue, Beijiao, Shunde, Foshan,  
Guangdong, China

Postal code: 528311

Tel: +86-757-26338346 Fax: +86-757-22390205

cac.midea.com    global.midea.com

Note: The data in this book may be changed without notice for further improvement on  
quality and performance.

Midea CAC After-service Application



iOS Version



Android Version

Midea CAC News Application



iOS Version