

TECHNICAL SUPPORT MANUAL

Split System Air Conditioner

R2AM, R2A3, WCA3**2

Safety Labeling and Signal Words

DANGER, WARNING, CAUTION, and NOTE

The signal words **DANGER**, **WARNING**, **CAUTION**, and **NOTE** are used to identify levels of hazard seriousness. The signal word **DANGER** is only used on product labels to signify an immediate hazard. The signal words **WARNING**, **CAUTION**, and **NOTE** will be used on product labels and throughout this manual and other manuals that may apply to the product.

DANGER – Immediate hazards which **will** result in severe personal injury or death.

WARNING – Hazards or unsafe practices which **could** result in severe personal injury or death.

CAUTION – Hazards or unsafe practices which **may** result in minor personal injury or product or property damage.

NOTE – Used to highlight suggestions which **will** result in enhanced installation, reliability, or operation.

Signal Words in Manuals

The signal word **WARNING** is used throughout this manual in the following manner:



The signal word **CAUTION** is used throughout this manual in the following manner:



Signal Words on Product Labeling

Signal words are used in combination with colors and/or pictures on product labels.

TABLE OF CONTENTS

Model Number Identification	2 – 3
Wiring Diagram	4 – 5
Charging Chart	6
Tech Labels (Expanded Data)	7 – 13
R2AM Parts Cooling Multiplying Factors	14
R2A3 Cooling Multiplying Factors	15 – 19
WCA3**2 Cooling Multiplying Factors	20
Exploded Drawing	21
R2AM Parts List	22 – 24
R2A3 Parts List	25 – 26
WCA3**2 Parts List	27 – 28



DEATH, PERSONAL INJURY, AND/OR PROPERTY DAMAGE HAZARD

Failure to carefully read and follow this warning could result in equipment malfunction, property damage, personal injury and/or death.

Installation or repairs made by unqualified persons could result in equipment malfunction, property damage, personal injury and/or death.

The information contained in this manual is intended for use by a qualified service technician familiar with safety procedures and equipped with the proper tools and test instruments.

Installation must conform with local building codes and with the National Electrical Code NFPA70 current edition or Canadian Electrical Code Part 1 CSA C.22.1.

OUTDOOR UNIT MODEL NUMBER IDENTIFICATION GUIDE (single phase)												
Digit Position:	1	2	3	4	5, 6	7	8	9	10	11	12	
Example Part Number:	R	2	A	3	18	A	K	C	1	0	0	
Product Family	REFRIGERANT		TYPE									
2 = R-22												
4 = R-410A												
A = Air Conditioner												
H = Heat Pump	NOMINAL EFFICIENCY											
M = NOM (13 SEER)												
3 = 13 SEER												
4 = 14 SEER												
18 = 18,000 BTUH = 1½ tons	NOMINAL CAPACITY											
24 = 24,000 BTUH = 2 tons												
30 = 30,000 BTUH = 2½ tons												
36 = 36,000 BTUH = 3 tons												
42 = 42,000 BTUH = 3½ tons												
48 = 48,000 BTUH = 4 tons												
60 = 60,000 BTUH = 5 tons												
A = Standard Grille	FEATURES											
G = Coil Guard Grille												
K = 208/230-1-60	VOLTAGE											
Sales Code												
Engineering Revision												
Extra Digit												
Extra Digit												

OUTDOOR UNIT MODEL NUMBER IDENTIFICATION GUIDE (single phase)									
Digit Position:	1,2	3	4	5,6	7	8	9	10	11
Example Part Number:	WC	A	3	24	2	G	K	A	1
WC = Condensing Unit									
A = Air Conditioner									
H = Heat Pump									
TYPE									
3 = 13 SEER									
4 = 14 SEER									
SEER									
18 = 18,000 BTUH = 1½ tons									
24 = 24,000 BTUH = 2 tons									
30 = 30,000 BTUH = 2½ tons									
36 = 36,000 BTUH = 3 tons									
42 = 42,000 BTUH = 3½ tons									
48 = 48,000 BTUH = 4 tons									
60 = 60,000 BTUH = 5 tons									
NOMINAL CAPACITY									
2 = R-22									
4 = R-410A									
REFRIGERANT									
A = Standard Grille									
G = Coil Guard Grille									
FEATURE									
K = 208/230-1-60									
VOLTAGE									
Sales Code									
Extra Digit									

ACCESSORIES PART NUMBER IDENTIFICATION GUIDE									
Digit Position:	1	2	3	4	5	6, 7	8, 9	10, 11	
Example Part Number:	N	A	S	A	0	01	01	CH	
N = Non-Branded									
BRANDING									
A = Accessory									
PRODUCT GROUP									
S = Split System (AC & HP)									
KIT USAGE									
A = Original									
B = 2nd Generation									
MAJOR SERIES									
0 = Generic or Not Applicable									
2 = R-22									
4 = R-410A									
REFRIGERANT									
Product Identifier Number									
Package Quantity									
Type of Kit (Example: CH = Crankcase Heater)									

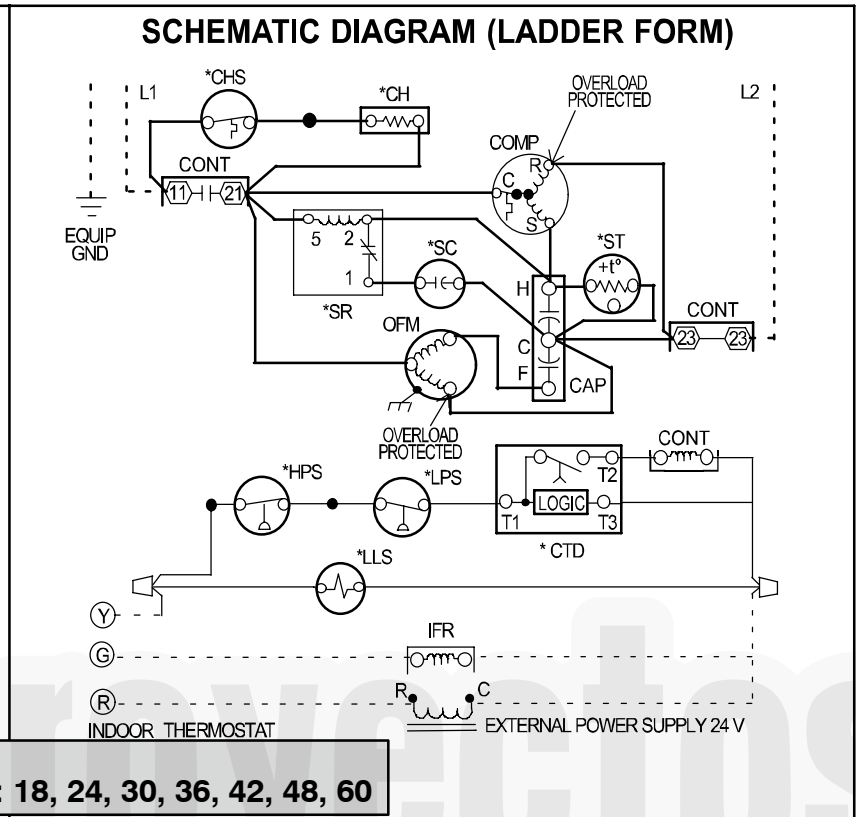
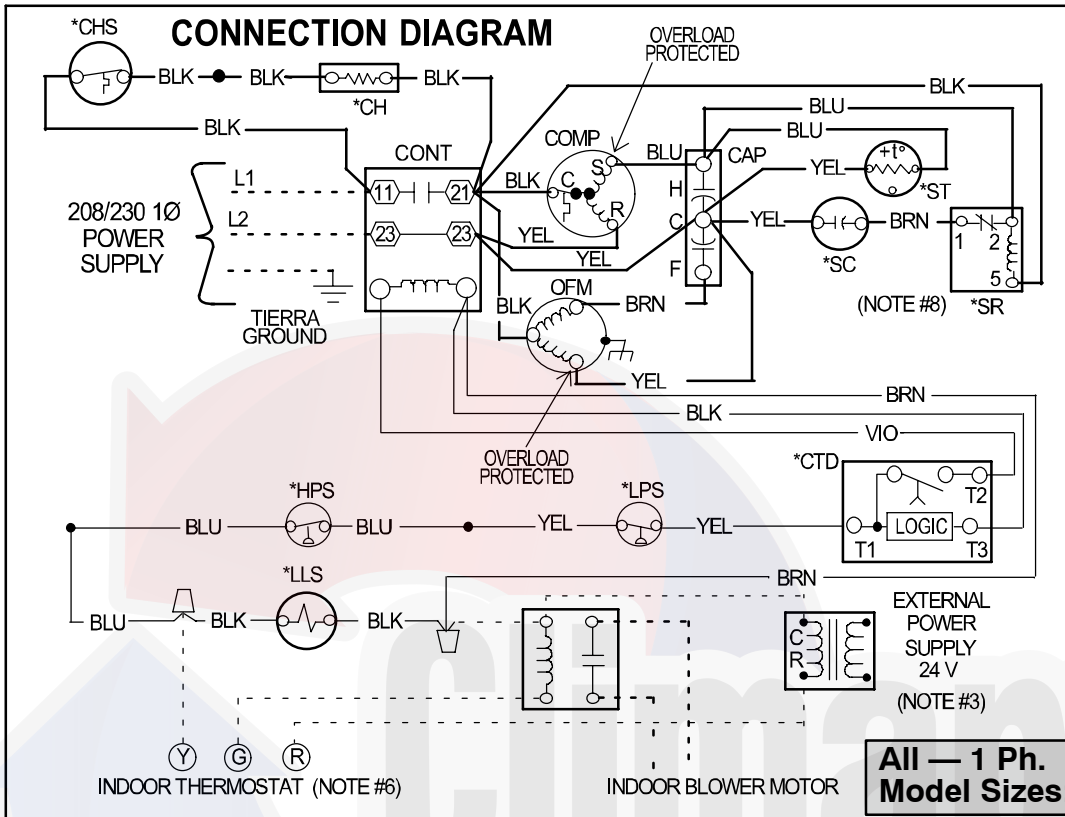

All — 1 Ph.
Model Sizes: 18, 24, 30, 36, 42, 48, 60

1. Symbols are electrical representation only.
2. Compressor and fan motor furnished with inherent thermal protection.
3. To be wired in accordance with National Electric N.E.C. and local codes.
4. N.E.C. class 2, 24 V circuit, min. 40 VA required, 60 VA on units installed with LLS.
5. Use copper conductors only. Use conductors suitable for at least 75°C (167°F).
6. Connection for typical cooling only thermostat. For other arrangements see installation instructions.
7. If indoor section has a transformer with a grounded secondary, connect the grounded side to the BRN/YEL lead.
8. When start capacitor and relay are installed, start thermistor (PTC) is not used.
9. CH not used on all units.
10. If any of the original wire, as supplied, must be replaced, use the same or equivalent wire.
11. Check all electrical connections inside control box for tightness.
12. Do not attempt to operate unit until service valves have been opened.
13. Do not rapid cycle compressor. Compressor must be off 3 minutes to allow pressures to equalize between high and low side before starting.
14. Wire not present if HPS, LPS or CTD are used.

LEGEND

—	FACTORY POWER WIRING
—	FACTORY CONTROL WIRING
- - -	FIELD CONTROL WIRING
- - -	FIELD POWER WIRING
○	COMPONENT CONNECTION
⊕	FIELD SPLICE
•	JUNCTION
⊔	PLUG RECEPTACLE
CONT	CONTACTOR
CAP	CAPACITOR (DUAL RUN)
*CH	CRANKCASE HEATER
*CHS	CRANKCASE HEATER SWITCH
COMP	COMPRESSOR
*CTD	COMPRESSOR TIME DELAY
*DTS	DISCHARGE TEMP SWITCH
*HPS	HIGH PRESSURE SWITCH
IFR	INDOOR FAN RELAY
*LLS	LIQ LINE SOLENOID VALVE
*LPS	LOW PRESSURE SWITCH
OFM	OUTDOOR FAN MOTOR
*SC	START CAPICATOR
*SR	START RELAY
*ST	START THERMISTOR

* MAY BE FACTORY INSTALLED

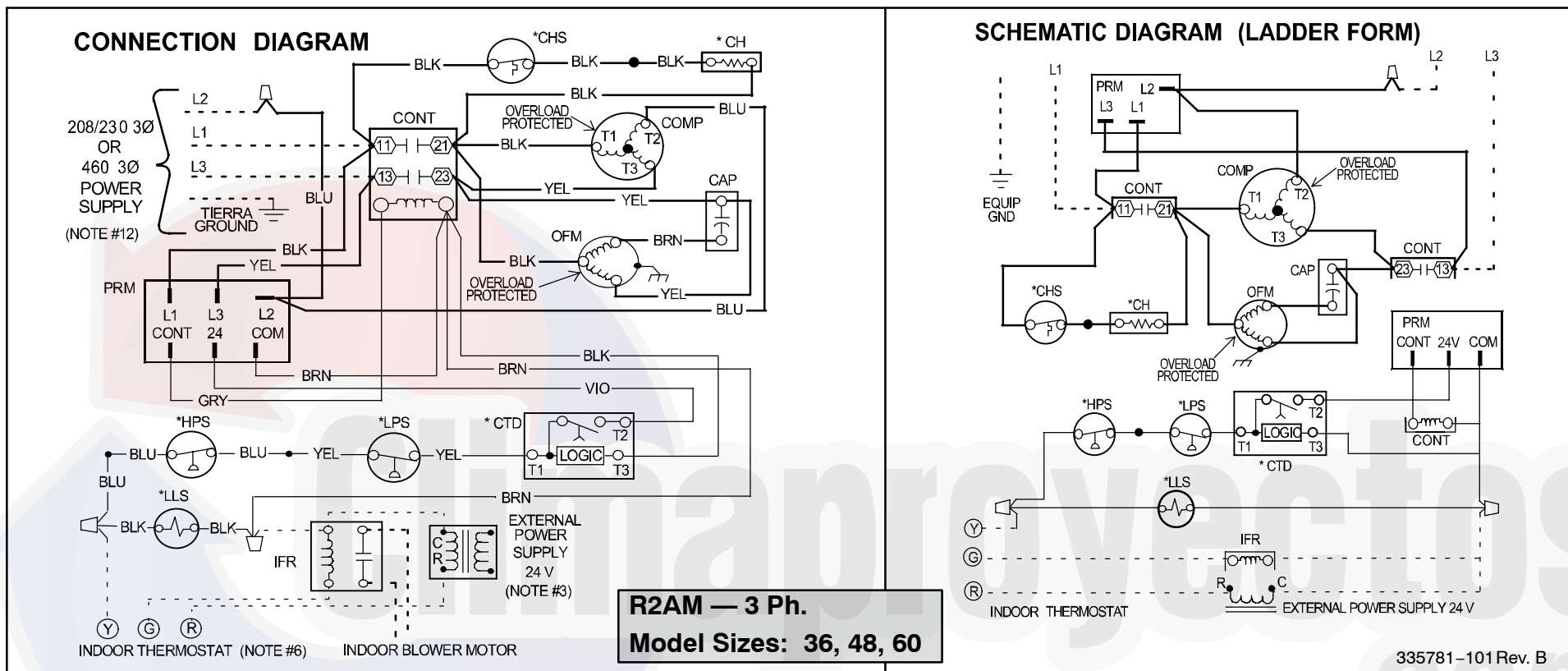

1. Symbols are electrical representation only.
2. Compressor and fan motor furnished with inherent thermal protection.
3. To be wired in accordance with National Electric N.E.C. and local codes.
4. N.E.C. class 2, 24 V circuit, min. 40 VA required, 60 VA on units installed with LLS.
5. Use copper conductors only. Use conductors suitable for at least 75°C (167°F).
6. Connection for typical cooling only thermostat. For other arrangements see installation instructions.
7. If indoor section has a transformer with a grounded secondary, connect the grounded side to the BRN/YEL lead.
8. When start capacitor and relay are installed, start thermistor (PTC) is not used.
9. CH not used on all units.
10. If any of the original wire, as supplied, must be replaced, use the same or equivalent wire.
11. Check all electrical connections inside control box for tightness.
12. Do not attempt to operate unit until service valves have been opened.
13. Do not rapid cycle compressor. Compressor must be off 3 minutes to allow pressures to equalize between high and low side before starting.
14. Wire not present if HPS, LPS or CTD are used.

LEGEND

—	FACTORY POWER WIRING
—	FACTORY CONTROL WIRING
- - -	FIELD CONTROL WIRING
- - -	FIELD POWER WIRING
- - -	COMPONENT CONNECTION
○	FIELD SPICE
●	JUNCTION
⊚	PLUG RECEPTACLE
CONT	CONTACTOR
CAP	CAPACITOR (DUAL RUN)
*CH	CRANKCASE HEATER
*CHS	CRANKCASE HEATER SWITCH
COMP	COMPRESSOR
*CTD	COMPRESSOR TIME DELAY
*DTS	DISCHARGE TEMP SWITCH
*HPS	HIGH PRESSURE SWITCH
IFR	INDOOR FAN RELAY
*LLS	LIQ LINE SOLENOID VALVE
*LPS	LOW PRESSURE SWITCH
OFM	OUTDOOR FAN MOTOR
*SC	START CAPICATOR
*SR	START RELAY
*ST	START THERMISTOR

* MAY BE FACTORY INSTALLED

R-22 CHARGING CHART

- Find the required Subcooling Temperature on the unit Rating Plate. Use the closest column on the chart below (5, 10, 15, or 20) .
- Add or remove refrigerant until both the Liquid Line Temperature and Liquid Pressure agree with chart data.

Measured Liquid Pressure (psig)	Rating Plate (required) Subcooling Temperature (° F)			
	5	10	15	20
R-22 Required Liquid Line Temperature (° F)				
163	83	78	73	68
171	86	81	76	71
179	89	84	79	74
187	92	87	82	77
196	95	90	85	80
205	98	93	88	83
214	101	96	91	86
223	104	99	94	89
233	107	102	97	92
243	110	105	100	95
253	113	108	103	98
264	116	111	106	101
274	119	114	109	104
285	122	117	112	107
297	125	120	115	110
309	128	123	118	113

COOLING		18 Size Outdoor With EB2X24** / W*A*242AA* Indoor Cooling																			
		Outdoor Ambient Temperature – Degrees F, Dry Bulb																			
		75				85				95				105				115			
		Entering Indoor Temperature – Degrees F, Wet Bulb																			
CFM		57	62	67	72	57	62	67	72	57	62	67	72	57	62	67	72	57	62	67	72
525	MBh†	16.03	16.56	18.25	20.18	15.41	15.78	17.43	19.30	14.83	15.05	16.65	18.50	14.26	14.37	15.91	17.76	13.74	13.75	15.20	17.04
	S/T‡	1.00	0.91	0.70	0.52	1.00	0.93	0.71	0.53	1.00	0.95	0.73	0.53	1.00	0.97	0.74	0.54	1.00	1.00	0.76	0.55
	AMPS*	5.58	5.56	5.49	5.41	6.07	6.06	6.02	5.95	6.63	6.63	6.61	6.56	7.28	7.28	7.28	7.26	8.03	8.03	8.06	8.06
	HI PR	164	165	167	169	192	192	195	198	223	223	226	229	257	257	260	264	295	295	298	302
	LO PR	73	75	82	91	75	77	84	92	77	78	85	93	79	80	86	95	81	81	88	96
600	MBh†	16.81	17.04	18.65	20.61	16.15	16.25	17.80	19.67	15.54	15.55	17.00	18.85	14.95	14.95	16.25	18.09	14.39	14.39	15.52	17.35
	S/T‡	1.00	0.95	0.73	0.54	1.00	0.98	0.75	0.55	1.00	1.00	0.76	0.55	1.00	1.00	0.78	0.56	1.00	1.00	0.80	0.57
	AMPS*	5.67	5.66	5.59	5.51	6.17	6.17	6.12	6.05	6.75	6.75	6.72	6.67	7.41	7.41	7.40	7.37	8.17	8.17	8.18	8.18
	HI PR	165	166	168	170	193	193	196	199	224	224	227	230	259	259	261	265	297	297	299	303
	LO PR	77	78	84	93	79	79	86	94	81	81	87	95	83	83	88	97	85	85	89	98
675	MBh†	17.45	17.48	18.96	20.93	16.77	16.76	18.08	19.96	16.12	16.12	17.26	19.10	15.52	15.51	16.50	18.32	14.93	14.93	15.76	17.57
	S/T‡	1.00	0.99	0.77	0.55	1.00	1.00	0.78	0.56	1.00	1.00	0.80	0.57	1.00	1.00	0.82	0.58	1.00	1.00	0.84	0.59
	AMPS*	5.76	5.76	5.70	5.61	6.27	6.27	6.23	6.15	6.86	6.86	6.83	6.78	7.53	7.53	7.52	7.49	8.30	8.30	8.31	8.30
	HI PR	166	166	168	171	194	194	196	199	225	225	227	231	260	260	262	266	298	298	300	304
	LO PR	80	80	86	95	82	82	87	96	84	84	89	97	86	86	90	98	87	87	91	99

† Total capacities are net (I.D. blower heat subtracted) system capacities based on 25' line set.
If additional tubing length and/or indoor unit is located above outdoor unit, a slight variation in capacity may occur.

†† At TVA rating indoor condition (75 °F db, 63 °F wb), all other indoor air temperatures are at 80 °F db
If additional tubing length and/or indoor unit is located above outdoor unit, a slight variation in capacity may occur.

^ System amps are total of indoor and outdoor amps.

‡ Chart data is for 80° F indoor dry bulb. For indoor db temperatures other than 80° F, measure Indoor db and Indoor CFM, and plug these into the formula below. Measure outdoor db and indoor wet bulb, apply these to the chart above, find MBh and S/T, and plug these into the formula below.
(Note: if indoor db is the only thing changing, total capacity, MBh, stays the same.)

$$\text{Sensible Capacity at Indoor db LOWER than } 80^\circ \text{ F} = (\text{MBh} \times \text{S/T}) - \left(\frac{(\text{80} - \text{Indoor db}) \times 835 \times \text{Indoor CFM}}{1000} \right)$$

$$\text{Sensible Capacity at Indoor db HIGHER than } 80^\circ \text{ F} = (\text{MBh} \times \text{S/T}) + \left(\frac{(\text{Indoor db} - 80) \times 835 \times \text{Indoor CFM}}{1000} \right)$$

COOLING		24 Size Outdoor With EB*2X24B** / W*A*242AA* Indoor Cooling																								
		Outdoor Ambient Temperature – Degrees F, Dry Bulb																								
		75					85					95					105					115				
		Entering Indoor Temperature – Degrees F, Wet Bulb																								
CFM		57	62	67	72	57	62	67	72	57	62	67	72	57	62	67	72	57	62	67	72					
700	MBh†	21.96	22.39	24.32	26.68	21.39	21.68	23.53	25.79	20.72	20.89	22.66	24.83	19.97	20.02	21.70	23.80	19.13	19.12	20.63	22.68					
	S/T‡	1.00	0.89	0.69	0.51	1.00	0.91	0.70	0.51	1.00	0.92	0.71	0.52	1.00	0.94	0.73	0.53	1.00	1.00	0.74	0.54					
	AMPS*	7.28	7.30	7.36	7.44	8.00	8.01	8.08	8.17	8.82	8.83	8.91	9.00	9.76	9.76	9.84	9.94	10.83	10.83	10.90	11.00					
	HI PR	168	168	171	173	197	198	201	204	230	230	233	237	264	265	268	272	302	302	306	310					
	LO PR	74	75	82	91	75	76	83	92	77	77	84	93	79	79	86	94	81	81	87	96					
800	MBh†	22.82	22.92	24.73	27.10	22.19	22.20	23.91	26.18	21.49	21.48	23.00	25.18	20.70	20.70	22.01	24.11	19.82	19.82	20.92	22.95					
	S/T‡	1.00	0.93	0.72	0.53	1.00	0.99	0.73	0.53	1.00	1.00	0.75	0.54	1.00	1.00	0.76	0.55	1.00	1.00	0.78	0.56					
	AMPS*	7.48	7.49	7.55	7.62	8.20	8.20	8.27	8.35	9.02	9.02	9.09	9.19	9.97	9.97	10.03	10.13	11.03	11.03	11.09	11.19					
	HI PR	169	169	171	174	199	199	201	205	231	231	234	237	266	266	269	273	304	304	307	311					
	LO PR	77	78	84	93	79	79	85	94	80	80	86	95	82	82	88	96	84	84	89	97					
900	MBh†	23.51	23.51	25.03	27.41	22.85	22.85	24.19	26.45	22.11	22.11	23.25	25.42	21.29	21.29	22.24	24.32	20.38	20.38	21.13	23.14					
	S/T‡	1.00	1.00	0.76	0.54	1.00	1.00	0.77	0.55	1.00	1.00	0.78	0.56	1.00	1.00	0.80	0.57	1.00	1.00	0.82	0.58					
	AMPS*	7.67	7.68	7.72	7.80	8.40	8.40	8.45	8.53	9.22	9.22	9.27	9.37	10.17	10.17	10.21	10.31	11.23	11.23	11.27	11.37					
	HI PR	170	170	172	175	200	200	202	205	233	233	234	238	268	268	270	274	306	306	308	312					
	LO PR	81	81	86	95	82	82	87	96	84	84	88	97	85	85	89	98	87	87	90	99					

- † Total capacities are net (I.D. blower heat subtracted) system capacities based on 25' line set. If additional tubing length and/or indoor unit is located above outdoor unit, a slight variation in capacity may occur.
- †† At TVA rating indoor condition (75 °F db, 63 °F wb), all other indoor air temperatures are at 80 °F db. If additional tubing length and/or indoor unit is located above outdoor unit, a slight variation in capacity may occur.
- ^ System amps are total of indoor and outdoor amps.
- ‡ Chart data is for 80° F indoor dry bulb. For indoor db temperatures other than 80° F, measure Indoor db and Indoor CFM, and plug these into the formula below. Measure outdoor db and indoor wet bulb, apply these to the chart above, find MBh and S/T, and plug these into the formula below. (Note: if indoor db is the only thing changing, total capacity, MBh, stays the same.)

Sensible Capacity at Indoor db LOWER than 80 °F = (MBh x S/T) - $\left(\frac{(80 - \text{Indoor db}) \times 835 \times \text{Indoor CFM}}{1000} \right)$

Sensible Capacity at Indoor db HIGHER than 80 °F = (MBh x S/T) + $\left(\frac{(\text{Indoor db} - 80) \times 835 \times \text{Indoor CFM}}{1000} \right)$

COOLING		30 Size Outdoor With EB*2X36F** / W*A*362BA* Indoor Cooling																								
		Outdoor Ambient Temperature – Degrees F, Dry Bulb																								
		75					85					95					105					115				
		Entering Indoor Temperature – Degrees F, Wet Bulb																								
CFM		57	62	67	72	57	62	67	72	57	62	67	72	57	62	67	72	57	62	67	72					
875	MBh†	26.88	27.35	29.65	32.52	26.11	26.43	28.69	31.46	25.27	25.44	27.60	30.31	24.38	24.42	26.46	29.12	23.44	23.44	25.27	27.88					
	S/T‡	1.00	0.91	0.71	0.52	1.00	0.93	0.72	0.53	1.00	0.95	0.73	0.53	1.00	0.99	0.74	0.54	1.00	1.00	0.76	0.55					
	AMPS*	8.88	8.91	9.01	9.07	9.78	9.79	9.88	9.93	10.76	10.77	10.85	10.89	11.86	11.86	11.94	11.97	13.11	13.11	13.18	13.20					
	HI PR	176	177	180	184	206	206	210	214	238	238	242	247	273	273	277	283	312	312	316	322					
	LO PR	73	75	82	90	75	76	83	91	77	77	84	93	79	79	85	94	81	81	87	95					
1000	MBh†	27.87	27.99	30.13	33.01	27.08	27.05	29.12	31.88	26.19	26.19	28.00	30.71	25.26	25.26	26.83	29.49	24.28	24.28	25.61	28.22					
	S/T‡	1.00	0.95	0.74	0.54	1.00	1.00	0.75	0.55	1.00	1.00	0.77	0.55	1.00	1.00	0.78	0.56	1.00	1.00	0.80	0.57					
	AMPS*	9.14	9.15	9.22	9.27	10.03	10.03	10.10	10.12	11.01	11.01	11.07	11.08	12.11	12.11	12.16	12.16	13.35	13.35	13.39	13.39					
	HI PR	178	178	181	185	207	207	211	215	240	240	243	248	275	275	278	284	314	314	317	323					
	LO PR	77	77	84	92	79	79	85	93	80	80	86	94	82	82	87	96	84	84	88	97					
1175	MBh†	29.00	29.01	30.58	33.46	28.14	28.13	29.53	32.27	27.21	27.20	28.39	31.08	26.23	26.22	27.20	29.82	25.20	25.20	25.96	28.52					
	S/T‡	1.00	1.00	0.79	0.56	1.00	1.00	0.80	0.57	1.00	1.00	0.82	0.58	1.00	1.00	0.84	0.59	1.00	1.00	0.86	0.60					
	AMPS*	9.48	9.48	9.52	9.54	10.36	10.36	10.39	10.39	11.33	11.33	11.36	11.35	12.43	12.43	12.44	12.43	13.67	13.67	13.68	13.66					
	HI PR	180	180	182	186	210	210	212	216	242	242	244	249	278	278	280	285	317	317	318	324					
	LO PR	81	81	86	94	83	83	87	95	84	84	88	96	86	86	89	97	88	88	90	98					

† Total capacities are net (I.D. blower heat subtracted) system capacities based on 25' line set.
If additional tubing length and/or indoor unit is located above outdoor unit, a slight variation in capacity may occur.

†† At TVA rating indoor condition (75 °F db, 63 °F wb), all other indoor air temperatures are at 80 °F db
If additional tubing length and/or indoor unit is located above outdoor unit, a slight variation in capacity may occur.

^ System amps are total of indoor and outdoor amps.

‡ Chart data is for 80° F indoor dry bulb. For indoor db temperatures other than 80° F, measure Indoor db and Indoor CFM, and plug these into the formula below. Measure outdoor db and indoor wet bulb, apply these to the chart above, find MBh and S/T, and plug these into the formula below.
(Note: if indoor db is the only thing changing, total capacity, MBh, stays the same.)

$$\text{Sensible Capacity at Indoor db LOWER than } 80^\circ \text{ F} = (\text{MBh} \times \text{S/T}) - \left(\frac{(\text{80} - \text{Indoor db}) \times 835 \times \text{Indoor CFM}}{1000} \right)$$

$$\text{Sensible Capacity at Indoor db HIGHER than } 80^\circ \text{ F} = (\text{MBh} \times \text{S/T}) + \left(\frac{(\text{Indoor db} - 80) \times 835 \times \text{Indoor CFM}}{1000} \right)$$

COOLING		36 Size Outdoor With EB*2X36F** / W*A*362BA* Indoor Cooling																								
		Outdoor Ambient Temperature – Degrees F, Dry Bulb																								
		75					85					95					105					115				
		Entering Indoor Temperature – Degrees F, Wet Bulb																								
CFM		57	62	67	72	57	62	67	72	57	62	67	72	57	62	67	72	57	62	67	72					
1050	MBh†	32.20	33.03	36.00	39.49	31.28	31.91	34.76	38.17	30.32	30.76	33.49	36.80	29.32	29.57	32.16	35.37	28.28	28.36	30.78	33.89					
	S/T‡	1.00	0.90	0.70	0.52	1.00	0.92	0.71	0.52	1.00	0.93	0.72	0.53	1.00	0.95	0.73	0.54	1.00	0.97	0.75	0.54					
	AMPS*	10.81	10.84	10.95	11.09	11.87	11.89	12.00	12.14	13.04	13.06	13.17	13.31	14.36	14.37	14.48	14.61	15.81	15.82	15.92	16.06					
	HI PR	159	159	161	163	188	188	190	192	219	219	221	224	254	254	256	259	291	291	293	297					
	LO PR	71	73	80	88	72	74	81	89	74	75	82	90	76	76	83	92	78	78	84	93					
1200	MBh†	33.45	33.79	36.60	40.12	32.48	32.65	35.31	38.75	31.46	31.51	34.00	37.33	30.41	30.38	32.64	35.85	29.30	29.30	31.22	34.32					
	S/T‡	1.00	0.94	0.73	0.53	1.00	0.96	0.74	0.54	1.00	0.97	0.75	0.55	1.00	1.00	0.77	0.55	1.00	1.00	0.78	0.56					
	AMPS*	11.10	11.11	11.22	11.37	12.16	12.16	12.27	12.41	13.34	13.34	13.44	13.58	14.65	14.65	14.74	14.88	16.11	16.11	16.19	16.32					
	HI PR	160	160	161	163	188	189	190	193	220	220	222	225	255	255	257	260	292	292	294	297					
	LO PR	74	75	82	90	76	76	83	91	77	78	84	92	79	79	85	93	81	81	86	95					
1350	MBh†	34.50	34.52	37.06	40.58	33.46	33.44	35.74	39.17	32.40	32.40	34.39	37.71	31.29	31.29	33.00	36.20	30.13	30.12	31.55	34.62					
	S/T‡	1.00	0.97	0.76	0.55	1.00	1.00	0.77	0.56	1.00	1.00	0.79	0.56	1.00	1.00	0.80	0.57	1.00	1.00	0.82	0.58					
	AMPS*	11.39	11.39	11.49	11.63	12.44	12.44	12.53	12.67	13.62	13.62	13.70	13.84	14.94	14.94	15.01	15.15	16.39	16.39	16.45	16.59					
	HI PR	160	160	162	164	189	189	191	193	221	221	223	225	256	256	257	260	293	293	295	298					
	LO PR	77	77	83	92	79	79	84	93	80	80	85	94	82	82	87	95	84	84	88	96					

- † Total capacities are net (I.D. blower heat subtracted) system capacities based on 25' line set. If additional tubing length and/or indoor unit is located above outdoor unit, a slight variation in capacity may occur.
- †† At TVA rating indoor condition (75 °F db, 63 °F wb), all other indoor air temperatures are at 80 °F db. If additional tubing length and/or indoor unit is located above outdoor unit, a slight variation in capacity may occur.
- ^ System amps are total of indoor and outdoor amps.
- ‡ Chart data is for 80° F indoor dry bulb. For indoor db temperatures other than 80° F, measure Indoor db and Indoor CFM, and plug these into the formula below. Measure outdoor db and indoor wet bulb, apply these to the chart above, find MBh and S/T, and plug these into the formula below. (Note: if indoor db is the only thing changing, total capacity, MBh, stays the same.)

$$\text{Sensible Capacity at Indoor db LOWER than } 80^\circ \text{ F} = (\text{MBh} \times \text{S/T}) - \left(\frac{(\text{80} - \text{Indoor db}) \times 835 \times \text{Indoor CFM}}{1000} \right)$$

$$\text{Sensible Capacity at Indoor db HIGHER than } 80^\circ \text{ F} = (\text{MBh} \times \text{S/T}) + \left(\frac{(\text{Indoor db} - 80) \times 835 \times \text{Indoor CFM}}{1000} \right)$$

COOLING		42 Size Outdoor With EB*2X48J** / W*A*482CA* Indoor Cooling																								
		Outdoor Ambient Temperature – Degrees F, Dry Bulb																								
		75					85					95					105					115				
		Entering Indoor Temperature – Degrees F, Wet Bulb																								
CFM		57	62	67	72	57	62	67	72	57	62	67	72	57	62	67	72	57	62	67	72					
1225	MBh†	37.84	38.80	42.39	46.49	36.74	37.45	40.92	44.90	35.59	36.05	39.37	43.25	34.40	34.62	37.76	41.52	33.14	33.16	36.09	39.73					
	S/T‡	1.00	0.84	0.65	0.48	1.00	0.85	0.66	0.48	1.00	0.87	0.67	0.49	1.00	0.88	0.68	0.50	1.00	0.99	0.69	0.50					
	AMPS*	12.51	12.53	12.62	12.74	13.87	13.89	13.98	14.09	15.40	15.41	15.50	15.61	17.09	17.10	17.19	17.31	18.95	18.96	19.05	19.17					
	HI PR	165	166	167	169	195	195	197	199	227	227	230	232	262	263	265	268	301	301	304	307					
	LO PR	71	73	80	89	73	74	81	90	74	75	82	91	76	77	84	92	78	78	85	93					
1400	MBh†	39.37	39.71	43.15	47.26	38.20	38.33	41.60	45.61	36.98	36.95	40.00	43.90	35.71	35.71	38.34	42.11	34.38	34.37	36.62	40.25					
	S/T‡	1.00	0.88	0.68	0.49	1.00	0.89	0.69	0.50	1.00	1.00	0.70	0.51	1.00	1.00	0.71	0.51	1.00	1.00	0.73	0.52					
	AMPS*	12.84	12.85	12.94	13.05	14.20	14.20	14.29	14.40	15.73	15.72	15.81	15.93	17.42	17.42	17.50	17.62	19.29	19.29	19.36	19.48					
	HI PR	166	166	168	169	196	196	198	200	228	228	230	233	264	264	266	269	302	302	305	308					
	LO PR	75	75	82	91	76	76	83	92	78	78	84	93	80	80	85	94	82	82	87	95					
1575	MBh†	40.61	40.59	43.70	47.81	39.38	39.38	42.11	46.13	38.10	38.09	40.47	44.36	36.76	36.76	38.77	42.52	35.36	35.36	37.00	40.61					
	S/T‡	1.00	1.00	0.71	0.51	1.00	1.00	0.72	0.52	1.00	1.00	0.73	0.52	1.00	1.00	0.75	0.53	1.00	1.00	0.77	0.54					
	AMPS*	13.16	13.16	13.24	13.36	14.52	14.52	14.60	14.71	16.05	16.05	16.11	16.23	17.74	17.74	17.80	17.92	19.61	19.61	19.67	19.79					
	HI PR	167	167	168	170	197	197	198	200	229	229	231	233	265	265	266	269	304	304	305	309					
	LO PR	78	78	84	92	79	79	85	93	81	81	86	94	83	83	87	95	84	84	88	97					

- † Total capacities are net (I.D. blower heat subtracted) system capacities based on 25' line set. If additional tubing length and/or indoor unit is located above outdoor unit, a slight variation in capacity may occur.
- †† At TVA rating indoor condition (75 °F db, 63 °F wb), all other indoor air temperatures are at 80 °F db. If additional tubing length and/or indoor unit is located above outdoor unit, a slight variation in capacity may occur.
- ^ System amps are total of indoor and outdoor amps.
- ‡ Chart data is for 80° F indoor dry bulb. For indoor db temperatures other than 80° F, measure Indoor db and Indoor CFM, and plug these into the formula below. Measure outdoor db and indoor wet bulb, apply these to the chart above, find MBh and S/T, and plug these into the formula below. (Note: if indoor db is the only thing changing, total capacity, MBh, stays the same.)

Sensible Capacity at Indoor db LOWER than 80 °F = (MBh x S/T) - $\left(\frac{(80 - \text{Indoor db}) \times 835 \times \text{Indoor CFM}}{1000} \right)$

Sensible Capacity at Indoor db HIGHER than 80 °F = (MBh x S/T) + $\left(\frac{(\text{Indoor db} - 80) \times 835 \times \text{Indoor CFM}}{1000} \right)$

COOLING		48 Size Outdoor With EB*2X60L** / W*A*602DA* Indoor Cooling																								
		Outdoor Ambient Temperature – Degrees F, Dry Bulb																								
		75					85					95					105					115				
		Entering Indoor Temperature – Degrees F, Wet Bulb																								
CFM		57	62	67	72	57	62	67	72	57	62	67	72	57	62	67	72	57	62	67	72					
1400	MBh†	43.26	44.59	48.98	54.00	41.85	42.83	47.06	51.98	40.42	41.06	45.14	49.95	38.95	39.28	43.19	47.88	37.44	37.50	41.18	45.76					
	S/T‡	1.00	0.91	0.70	0.52	1.00	0.93	0.71	0.53	1.00	0.95	0.73	0.53	1.00	0.97	0.74	0.54	1.00	0.99	0.76	0.55					
	AMPS*	14.78	14.84	15.04	15.26	16.06	16.11	16.33	16.58	17.49	17.54	17.80	18.08	19.08	19.11	19.42	19.76	20.84	20.85	21.20	21.61					
	HI PR	169	170	172	174	199	200	202	205	231	232	235	239	267	267	271	275	306	306	310	315					
	LO PR	71	73	80	88	73	74	81	89	74	75	82	91	76	77	84	92	78	79	85	93					
1600	MBh†	45.21	45.76	49.97	55.05	43.70	43.97	47.98	52.95	42.19	42.23	46.00	50.84	40.64	40.63	43.98	48.69	39.04	39.04	41.91	46.50					
	S/T‡	1.00	0.95	0.73	0.54	1.00	0.97	0.75	0.54	1.00	0.99	0.76	0.55	1.00	1.00	0.78	0.56	1.00	1.00	0.80	0.57					
	AMPS*	15.20	15.22	15.41	15.63	16.49	16.50	16.71	16.96	17.94	17.95	18.18	18.47	19.56	19.56	19.81	20.15	21.35	21.35	21.61	22.01					
	HI PR	170	171	173	175	200	200	203	206	233	233	236	240	269	269	272	276	308	308	311	316					
	LO PR	74	75	82	90	76	76	83	91	78	78	84	93	80	80	86	94	82	82	87	95					
1800	MBh†	46.81	46.88	50.71	55.81	45.23	45.22	48.68	53.66	43.64	43.64	46.64	51.48	42.02	42.02	44.57	49.27	40.35	40.35	42.46	47.02					
	S/T‡	1.00	0.99	0.76	0.55	1.00	1.00	0.78	0.56	1.00	1.00	0.80	0.57	1.00	1.00	0.81	0.58	1.00	1.00	0.84	0.59					
	AMPS*	15.60	15.60	15.77	15.99	16.90	16.90	17.08	17.32	18.37	18.37	18.55	18.83	20.01	20.01	20.19	20.52	21.82	21.82	22.00	22.39					
	HI PR	171	171	173	175	201	201	204	207	234	234	237	240	270	270	273	277	309	309	312	317					
	LO PR	77	77	84	92	79	79	85	93	81	81	86	94	83	83	87	95	85	85	88	97					

† Total capacities are net (I.D. blower heat subtracted) system capacities based on 25' line set.
If additional tubing length and/or indoor unit is located above outdoor unit, a slight variation in capacity may occur.

†† At TVA rating indoor condition (75 °F db, 63 °F wb), all other indoor air temperatures are at 80 °F db
If additional tubing length and/or indoor unit is located above outdoor unit, a slight variation in capacity may occur.

^ System amps are total of indoor and outdoor amps.

‡ Chart data is for 80° F indoor dry bulb. For indoor db temperatures other than 80° F, measure Indoor db and Indoor CFM, and plug these into the formula below. Measure outdoor db and indoor wet bulb, apply these to the chart above, find MBh and S/T, and plug these into the formula below.
(Note: if indoor db is the only thing changing, total capacity, MBh, stays the same.)

$$\text{Sensible Capacity at Indoor db LOWER than } 80^\circ \text{ F} = (\text{MBh} \times \text{S/T}) - \left(\frac{(\text{80} - \text{Indoor db}) \times 835 \times \text{Indoor CFM}}{1000} \right)$$

$$\text{Sensible Capacity at Indoor db HIGHER than } 80^\circ \text{ F} = (\text{MBh} \times \text{S/T}) + \left(\frac{(\text{Indoor db} - 80) \times 835 \times \text{Indoor CFM}}{1000} \right)$$

COOLING		60 Size Outdoor With EB*2X60L** / W*A*602DA* Indoor Cooling																								
		Outdoor Ambient Temperature – Degrees F, Dry Bulb																								
		75					85					95					105					115				
		Entering Indoor Temperature – Degrees F, Wet Bulb																								
CFM		57	62	67	72	57	62	67	72	57	62	67	72	57	62	67	72	57	62	67	72					
1750	MBh†	54.71	55.82	60.82	66.73	53.01	53.75	58.53	64.28	51.22	51.62	56.15	61.69	49.33	49.43	53.64	58.96	47.32	47.32	51.01	56.11					
	S/T‡	1.00	0.92	0.71	0.52	1.00	0.94	0.72	0.53	1.00	0.95	0.73	0.54	1.00	0.97	0.75	0.54	1.00	1.00	0.77	0.55					
	AMPS*	18.05	18.09	18.27	18.48	19.86	19.89	20.08	20.32	21.84	21.86	22.07	22.33	24.00	24.01	24.24	24.53	26.32	26.32	26.57	26.89					
	HI PR	175	176	179	182	205	206	209	213	238	238	242	247	273	273	278	283	312	312	316	321					
	LO PR	71	72	79	87	72	73	80	89	74	75	81	90	76	76	83	91	78	78	84	93					
2000	MBh†	56.82	57.13	61.84	67.79	55.01	55.06	59.48	65.25	53.10	53.10	57.00	62.56	51.10	51.09	54.41	59.74	48.97	48.96	51.69	56.79					
	S/T‡	1.00	0.96	0.74	0.54	1.00	0.99	0.76	0.55	1.00	1.00	0.77	0.56	1.00	1.00	0.79	0.57	1.00	1.00	0.81	0.58					
	AMPS*	18.54	18.55	18.72	18.94	20.35	20.35	20.53	20.77	22.35	22.35	22.53	22.79	24.52	24.52	24.70	24.99	26.86	26.86	27.04	27.35					
	HI PR	177	177	179	183	207	207	210	214	240	240	243	248	276	276	279	284	314	314	317	323					
	LO PR	74	75	81	89	76	76	82	91	78	78	83	92	80	80	85	93	82	82	86	94					
2250	MBh†	58.54	58.54	62.62	68.56	56.64	56.63	60.18	65.95	54.64	54.63	57.63	63.18	52.53	52.52	54.97	60.28	50.29	50.29	52.19	57.24					
	S/T‡	1.00	1.00	0.78	0.56	1.00	1.00	0.79	0.57	1.00	1.00	0.81	0.58	1.00	1.00	0.83	0.59	1.00	1.00	0.85	0.60					
	AMPS*	19.01	19.01	19.16	19.37	20.83	20.83	20.97	21.21	22.83	22.83	22.97	23.23	25.02	25.02	25.15	25.43	27.37	27.37	27.49	27.80					
	HI PR	178	178	180	183	208	208	211	215	241	241	244	248	277	277	280	285	316	316	318	323					
	LO PR	77	77	83	91	79	79	84	92	81	81	85	93	82	82	86	94	84	84	88	96					

† Total capacities are net (I.D. blower heat subtracted) system capacities based on 25' line set.
If additional tubing length and/or indoor unit is located above outdoor unit, a slight variation in capacity may occur.

†† At TVA rating indoor condition (75 °F db, 63 °F wb), all other indoor air temperatures are at 80 °F db
If additional tubing length and/or indoor unit is located above outdoor unit, a slight variation in capacity may occur.

^ System amps are total of indoor and outdoor amps.

‡ Chart data is for 80° F indoor dry bulb. For indoor db temperatures other than 80° F, measure Indoor db and Indoor CFM, and plug these into the formula below. Measure outdoor db and indoor wet bulb, apply these to the chart above, find MBh and S/T, and plug these into the formula below.
(Note: if indoor db is the only thing changing, total capacity, MBh, stays the same.)

$$\text{Sensible Capacity at Indoor db LOWER than } 80^\circ \text{ F} = (\text{MBh} \times \text{S/T}) - \left(\frac{(80 - \text{Indoor db}) \times 835 \times \text{Indoor CFM}}{1000} \right)$$

$$\text{Sensible Capacity at Indoor db HIGHER than } 80^\circ \text{ F} = (\text{MBh} \times \text{S/T}) + \left(\frac{(\text{Indoor db} - 80) \times 835 \times \text{Indoor CFM}}{1000} \right)$$

COOLING Multiplying Factors for other Indoor Combinations (continued)								
Indoor Model	Capac. (MBh)	Power (AMPS)	Indoor Model	Capac. (MBh)	Power (AMPS)	Indoor Model	Capac. (MBh)	Power (AMPS)
R2AM18								
FEM2X18****	1.02	1.02	FS(M,U)2X24***	0.96	0.96	FSA2X24****	0.96	0.96
FEM2X24****	0.96	0.88	FSA2X18****	0.96	0.96	FVM2X24****	0.96	0.88
R2AM24								
FEM2X24****	0.98	0.98	FS(M,U)2X30***	0.98	0.98	FVM2X24****	1.00	0.92
FEM2X30****	1.00	1.00	FSA2X24****	0.98	0.98	FVM2X36****	0.99	0.91
FS(M,U)2X24***	0.98	0.98	FSA2X30****	0.98	0.98			
R2AM30								
FEM2X30****	0.96	0.96	FS(M,U)2X30***	0.96	0.96	FSM2X36****	1.00	1.00
FEM2X35****	1.00	1.00	FSA2X30****	0.96	0.96	FVM2X24****	1.00	1.00
FEM2X36****	1.00	1.00	FSA2X36****	1.00	1.00	FVM2X36****	1.00	0.92
						FVM2X48****	1.00	0.92
R2AM36								
Indoor Model	Capac. (MBh)	Power (AMPS)	Indoor Model	Capac. (MBh)	Power (AMPS)	Indoor Model	Capac. (MBh)	Power (AMPS)
FEM2X35****	1.00	1.00	FSA2X36****	1.00	1.00	FVM2X36****	1.00	0.92
FEM2X36****	1.00	1.00	FSM2X36****	1.00	1.00	FVM2X48****	1.00	0.92
FEM2X42****	1.00	1.00	FSU2X36****	1.00	1.00	FVM2X60****	1.00	0.92
FS(M,U)2X42***	1.00	1.00	FVM2X24****	0.97	0.97			
R2AM42								
FEM2X48****	1.00	1.00	FVM2X36****	0.98	0.98	FVM2X60****	1.00	0.92
FS(M,U)2X48***	1.00	1.00	FVM2X48****	1.00	1.00			
R2AM48								
FEM2X60****	1.00	1.00	FS(M,U)2X60***	1.00	1.00	FVM2X60****	1.00	1.00
R2AM60								
FEM2X60****	1.00	1.00	FS(M,U)2X60***	0.98	0.98	FVM2X60****	1.00	1.00

> Indicates Tested Indoor Model

COOLING Multiplying Factors for other Indoor Combinations

Indoor Model	Furnace Model	Capac. (MBh)	Power (AMPS)	Indoor Model	Furnace Model	Capac. (MBh)	Power (AMPS)	Indoor Model	Furnace Model	Capac. (MBh)	Power (AMPS)
R2A318											
>EB*2X24B**		1.00	1.00	ED*2X18B**	MV08B15**B*	0.96	0.88	EHD2X24A**	*9MPV075	0.96	0.88
EB*2X18B**	*8MPV050	0.96	0.96	ED*2X18B**		0.96	0.96	EHD2X24A**	MV08B15**B*	0.96	0.88
EB*2X18B**	MV08B15**B*	0.96	0.88	ED*2X24B**	*8MPV050	0.96	0.88	EHD2X24A**		1.00	1.00
EB*2X18B**		0.96	0.96	ED*2X24B**	MV08B15**B*	0.96	0.88	EMA2X24D**		1.00	1.00
EB*2X24B**	*8MPV050	0.96	0.88	ED*2X24B**		1.00	1.00	FEM2X18***		1.02	1.02
EB*2X24B**	MV08B15**B*	0.96	0.88	ED*2X24F**	*9MPV050	0.96	0.88	FEM2X24***		0.96	0.88
EB*2X24F**	*9MPV050	0.96	0.88	ED*2X24F**	*9MPV075	0.96	0.88	FS(M,U)2X24***		0.96	0.96
EB*2X24F**	*9MPV075	0.96	0.88	ED*2X24F**		1.00	1.00	FSA2X18***		0.96	0.96
EB*2X24F**		1.00	1.00	EHD2X24A**	*8MPV050	0.96	0.88	FSA2X24***		0.96	0.96
ED*2X18B**	*8MPV050	0.96	0.96	EHD2X24A**	*9MPV050	0.96	0.88	FVM2X24***		0.96	0.88
R2A324											
>EB*2X24B**		1.00	1.00	EHD2X24A**	*8MPV100	1.00	0.92	EB*2X30B**	MV08B15**B*	1.00	0.92
FEM2X24***		0.98	0.98	EHD2X30A**	*8MPV100	1.00	0.92	ED*2X24B**	MV08B15**B*	1.00	0.92
FEM2X30***		1.00	1.00	EHD2X24A**	*8MPV125	1.00	0.92	ED*2X30B**	MV08B15**B*	1.00	0.92
FS(M,U)2X24***		0.98	0.98	EHD2X30A**	*8MPV125	1.00	0.92	EHD2X24A**	MV08B15**B*	1.00	0.92
FS(M,U)2X30***		0.98	0.98	EB*2X24F**	*9MPV050	1.00	1.00	EHD2X30A**	MV08B15**B*	1.00	0.92
FSA2X24***		0.98	0.98	EB*2X30F**	*9MPV050	1.00	1.00	EB*2X24F**	MV12F19**B*	1.00	0.92
FSA2X30***		0.98	0.98	ED*2X24F**	*9MPV050	1.00	1.00	EB*2X30F**	MV12F19**B*	1.00	0.92
FVM2X24***		1.00	0.92	ED*2X30F**	*9MPV050	1.00	1.00	ED*2X24F**	MV12F19**B*	1.00	0.92
FVM2X36***		0.99	0.91	EHD2X24A**	*9MPV050	1.00	1.00	ED*2X30F**	MV12F19**B*	1.00	0.92
EB*2X24B**	*8MPV050	1.00	1.00	EHD2X30A**	*9MPV050	1.00	1.00	EHD2X24A**	MV12F19**B*	1.00	0.92
EB*2X30B**	*8MPV050	1.00	1.00	EB*2X24F**	*9MPV075	1.00	1.00	EHD2X30A**	MV12F19**B*	1.00	0.92
ED*2X24B**	*8MPV050	1.00	1.00	EB*2X30F**	*9MPV075	1.00	1.00	EB*2X24F**		1.00	1.00
ED*2X30B**	*8MPV050	1.00	1.00	ED*2X24F**	*9MPV075	1.00	1.00	EB*2X30B**		1.00	1.00
EHD2X24A**	*8MPV050	1.00	1.00	ED*2X30F**	*9MPV075	1.00	1.00	EB*2X30F**		1.00	1.00

> Indicates Tested Indoor Model

- continued on next page -

COOLING Multiplying Factors for other Indoor Combinations (continued)

Indoor Model	Furnace Model	Capac. (MBh)	Power (AMPS)	Indoor Model	Furnace Model	Capac. (MBh)	Power (AMPS)	Indoor Model	Furnace Model	Capac. (MBh)	Power (AMPS)
EHD2X30A**	*8MPV050	1.00	1.00	EHD2X24A**	*9MPV075	1.00	1.00	ED*2X24B**		1.00	1.00
EB*2X24F**	*8MPV075	1.00	0.92	EHD2X30A**	*9MPV075	1.00	1.00	ED*2X24F**		1.00	1.00
EB*2X30F**	*8MPV075	1.00	0.92	EHD2X24A**	*9MPV100	1.00	1.00	ED*2X30B**		1.00	1.00
ED*2X24F**	*8MPV075	1.00	0.92	EHD2X30A**	*9MPV100	1.00	1.00	ED*2X30F**		1.00	1.00
ED*2X30F**	*8MPV075	1.00	0.92	EHD2X24A**	*9MPV125	1.00	1.00	EHD2X24A**		1.00	1.00
EHD2X24A**	*8MPV075	1.00	1.00	EHD2X30A**	*9MPV125	1.00	0.92	EHD2X30A**		1.00	1.00
EHD2X30A**	*8MPV075	1.00	0.92	EB*2X24B**	MV08B15**B*	1.00	0.92	EMA2X24D**		1.00	1.00
R2A330											
>EB*2X36F**		1.00	1.00	ED*2X30F**	*9MPV075	1.00	1.00	EHD2X30A**		0.96	0.96
EB*2X30B**	MV08B15**B*	1.00	1.00	ED*2X30F**	MV12F19**B*	1.00	0.92	EHD2X36A**	*8MPV075	1.00	1.00
EB*2X30B**		0.96	0.96	ED*2X30F**		0.96	0.96	EHD2X36A**	*8MPV100	1.00	0.92
EB*2X30F**	*8MPV075	1.00	1.00	ED*2X36B**	MV08B15**B*	1.00	1.00	EHD2X36A**	*8MPV125	1.00	1.00
EB*2X30F**	*9MPV050	0.96	0.96	ED*2X36B**		1.00	1.00	EHD2X36A**	*9MPV050	1.00	1.00
EB*2X30F**	*9MPV075	0.96	0.96	ED*2X36F**	*8MPV075	1.00	1.00	EHD2X36A**	*9MPV075	1.00	1.00
EB*2X30F**	MV12F19**B*	1.00	0.92	ED*2X36F**	*9MPV050	1.00	1.00	EHD2X36A**	*9MPV100	1.00	1.00
EB*2X30F**		0.96	0.96	ED*2X36F**	*9MPV075	1.00	1.00	EHD2X36A**	*9MPV125	1.00	0.92
EB*2X36B**	MV08B15**B*	1.00	1.00	ED*2X36F**	MV12F19**B*	1.00	0.92	EHD2X36A**	MV08B15**B*	1.00	0.92
EB*2X36B**		1.00	1.00	ED*2X36F**		1.00	1.00	EHD2X36A**	MV12F19**B*	1.00	0.92
EB*2X36F**	*8MPV075	1.00	1.00	ED*2X36J**	*8MPV125	1.00	1.00	EHD2X36A**		1.00	1.00
EB*2X36F**	*9MPV050	1.00	1.00	ED*2X36J**	*9MPV100	1.00	1.00	EMA2X36D**		1.00	1.00
EB*2X36F**	*9MPV075	1.00	1.00	ED*2X36J**		1.00	1.00	FEM2X30***		0.96	0.96
EB*2X36F**	MV12F19**B*	1.00	0.92	EHD2X30A**	*8MPV075	1.00	1.00	FEM2X35***		1.00	1.00
EB*2X36J**	*8MPV100	1.00	1.00	EHD2X30A**	*8MPV100	1.00	1.00	FEM2X36***		1.00	1.00
EB*2X36J**	*8MPV125	1.00	1.00	EHD2X30A**	*8MPV125	1.00	1.00	FS(M,U)2X30***		0.96	0.96
EB*2X36J**	*9MPV100	1.00	1.00	EHD2X30A**	*9MPV050	0.96	0.96	FSA2X30***		0.96	0.96
EB*2X36J**		1.00	1.00	EHD2X30A**	*9MPV075	0.96	0.96	FSA2X36***		1.00	1.00

> Indicates Tested Indoor Model

- continued on next page -

COOLING Multiplying Factors for other Indoor Combinations (continued)											
Indoor Model	Furnace Model	Capac. (MBh)	Power (AMPS)	Indoor Model	Furnace Model	Capac. (MBh)	Power (AMPS)	Indoor Model	Furnace Model	Capac. (MBh)	Power (AMPS)
ED*2X30B**	MV08B15**B*	1.00	1.00	EHD2X30A**	*9MPV100	1.00	1.00	FSM2X36***		1.00	1.00
ED*2X30B**		0.96	0.96	EHD2X30A**	*9MPV125	1.00	1.00	FVM2X24***		1.00	1.00
ED*2X30F**	*8MPV075	1.00	1.00	EHD2X30A**	MV08B15**B*	1.00	0.92	FVM2X36***		1.00	0.92
ED*2X30F**	*9MPV050	0.96	0.96	EHD2X30A**	MV12F19**B*	1.00	0.92	FVM2X48***		1.00	0.92
R2A336											
>EB*2X36F**		1.00	1.00	ED*2X36J**	*8MPV100	1.00	1.00	EHD2X36A**	MV20L24**B*	1.00	0.92
EB*2X36B**	MV08B15**B*	1.00	1.00	ED*2X36J**	*8MPV125	1.00	1.00	EHD2X36A**		1.00	1.00
EB*2X36B**		0.97	0.97	ED*2X36J**	*9MPV100	1.00	1.00	EHD2X42A**	*8MPV075	1.00	1.00
EB*2X36F**	*8MPV075	1.00	1.00	ED*2X36J**	MV16J22**B*	1.00	0.92	EHD2X42A**	*8MPV100	1.00	1.00
EB*2X36F**	MV12F19**B*	1.00	1.00	ED*2X36J**		1.00	1.00	EHD2X42A**	*8MPV125	1.00	0.92
EB*2X36J**	*8MPV100	1.00	1.00	ED*2X42F**	*8MPV075	1.00	1.00	EHD2X42A**	*9MPV050	1.00	1.00
EB*2X36J**	*8MPV125	1.00	1.00	ED*2X42F**	MV12F19**B*	1.00	0.92	EHD2X42A**	*9MPV075	1.00	1.00
EB*2X36J**	*9MPV100	1.00	1.00	ED*2X42F**		1.00	1.00	EHD2X42A**	*9MPV100	1.00	1.00
EB*2X36J**	MV16J22**B*	1.00	0.92	ED*2X42J**	*8MPV100	1.00	1.00	EHD2X42A**	*9MPV125	1.00	1.00
EB*2X36J**		1.00	1.00	ED*2X42J**	*8MPV125	1.00	1.00	EHD2X42A**	MV08B15**B*	1.00	0.92
EB*2X42F**	*8MPV075	1.00	1.00	ED*2X42J**	*9MPV100	1.00	1.00	EHD2X42A**	MV12F19**B*	1.00	0.92
EB*2X42F**	MV12F19**B*	1.00	0.92	ED*2X42J**	MV16J22**B*	1.00	0.92	EHD2X42A**	MV16J22**B*	1.00	0.92
EB*2X42F**		1.00	1.00	ED*2X42J**		1.00	1.00	EHD2X42A**	MV20L24**B*	1.00	0.92
EB*2X42J**	*8MPV100	1.00	1.00	ED*2X42L**	*9MPV125	1.00	1.00	EHD2X42A**		1.00	1.00
EB*2X42J**	*8MPV125	1.00	1.00	ED*2X42L**	MV20L24**B*	1.00	0.92	EMA2X36D**		1.00	1.00
EB*2X42J**	*9MPV100	1.00	1.00	ED*2X42L**		1.00	1.00	FEM2X35***		1.00	1.00
EB*2X42J**	MV16J22**B*	1.00	0.92	EHD2X36A**	*8MPV075	1.00	1.00	FEM2X36***		1.00	1.00
EB*2X42J**		1.00	1.00	EHD2X36A**	*8MPV100	1.00	1.00	FEM2X42***		1.00	1.00
EB*2X42L**	*9MPV125	1.00	1.00	EHD2X36A**	*8MPV125	1.00	1.00	FS(M,U)2X42***		1.00	1.00
EB*2X42L**	MV20L24**B*	1.00	0.92	EHD2X36A**	*9MPV050	1.00	1.00	FSA2X36***		1.00	1.00
EB*2X42L**		1.00	1.00	EHD2X36A**	*9MPV075	1.00	1.00	FSM2X36***		1.00	1.00
ED*2X36B**	MV08B15**B*	1.00	1.00	EHD2X36A**	*9MPV100	1.00	1.00	FSU2X36***		1.00	1.00

> Indicates Tested Indoor Model

- continued on next page -

COOLING Multiplying Factors for other Indoor Combinations (continued)

Indoor Model	Furnace Model	Capac. (MBh)	Power (AMPS)	Indoor Model	Furnace Model	Capac. (MBh)	Power (AMPS)	Indoor Model	Furnace Model	Capac. (MBh)	Power (AMPS)
ED*2X36B**		0.97	0.97	EHD2X36A**	*9MPV125	1.00	1.00	FVM2X24***		0.97	0.97
ED*2X36F**	*8MPV075	1.00	1.00	EHD2X36A**	MV08B15**B*	1.00	0.92	FVM2X36***		1.00	0.92
ED*2X36F**	MV12F19**B*	1.00	1.00	EHD2X36A**	MV12F19**B*	1.00	0.92	FVM2X48***		1.00	0.92
ED*2X36F**		1.00	1.00	EHD2X36A**	MV16J22**B*	1.00	0.92	FVM2X60***		1.00	0.92
R2A342											
>EB*2X48J**		1.00	1.00	ED*2X42J**	*8MPV125	0.98	0.98	EHD2X42A**	MV12F19**B*	0.98	0.98
EB*2X42F**	MV12F19**B*	0.98	0.98	ED*2X42J**	MV16J22**B*	0.98	0.98	EHD2X42A**	MV16J22**B*	0.98	0.98
EB*2X42J**	*8MPV100	0.98	0.98	ED*2X42L**	*9MPV125	0.98	0.98	EHD2X42A**	MV20L24**B*	0.98	0.98
EB*2X42J**	*8MPV125	0.98	0.98	ED*2X42L**	MV20L24**B*	0.98	0.98	EHD2X48A**	*8MPV100	0.98	0.98
EB*2X42J**	MV16J22**B*	0.98	0.98	ED*2X48F**	MV12F19**B*	0.98	0.98	EHD2X48A**	*8MPV125	0.98	0.98
EB*2X42L**	*9MPV125	0.98	0.98	ED*2X48F**		1.00	1.00	EHD2X48A**	*9MPV100	1.00	1.00
EB*2X42L**	MV20L24**B*	0.98	0.98	ED*2X48J**	*8MPV100	0.98	0.98	EHD2X48A**	*9MPV125	1.00	1.00
EB*2X48F**	MV12F19**B*	0.98	0.98	ED*2X48J**	*8MPV125	0.98	0.98	EHD2X48A**	MV12F19**B*	1.00	1.00
EB*2X48F**		1.00	1.00	ED*2X48J**	*9MPV100	0.98	0.98	EHD2X48A**	MV16J22**B*	1.00	0.92
EB*2X48J**	*8MPV100	0.98	0.98	ED*2X48J**	MV16J22**B*	0.98	0.98	EHD2X48A**	MV20L24**B*	1.00	0.92
EB*2X48J**	*8MPV125	0.98	0.98	ED*2X48J**		1.00	1.00	EMA2X48D**		0.98	0.98
EB*2X48J**	*9MPV100	0.98	0.98	ED*2X48L**	*9MPV125	0.98	0.98	FEM2X48***		1.00	1.00
EB*2X48J**	MV16J22**B*	0.98	0.89	ED*2X48L**	MV20L24**B*	0.98	0.89	FS(M,U)2X48***		1.00	1.00
EB*2X48L**	*9MPV125	0.98	0.98	ED*2X48L**		1.00	1.00	FVM2X36***		0.98	0.98
EB*2X48L**	MV20L24**B*	0.98	0.98	EHD2X42A**	*8MPV100	0.98	0.98	FVM2X48***		1.00	1.00
EB*2X48L**		1.00	1.00	EHD2X42A**	*8MPV125	0.98	0.98	FVM2X60***		1.00	0.92
ED*2X42F**	MV12F19**B*	0.98	0.98	EHD2X42A**	*9MPV100	0.98	0.98				
ED*2X42J**	*8MPV100	0.98	0.98	EHD2X42A**	*9MPV125	0.98	0.98				

> Indicates Tested Indoor Model

- continued on next page -

COOLING Multiplying Factors for other Indoor Combinations (continued)

Indoor Model	Furnace Model	Capac. (MBh)	Power (AMPS)	Indoor Model	Furnace Model	Capac. (MBh)	Power (AMPS)	Indoor Model	Furnace Model	Capac. (MBh)	Power (AMPS)
R2A348											
>EB*2X60L**		1.00	1.00	ED*2X48L**	MV20L24**B*	0.98	0.98	EHD2X60A**	*8MPV100	0.98	0.98
EB*2X48J**	MV16J22**B*	0.98	0.98	ED*2X60J**	*8MPV125	0.98	0.98	EHD2X60A**	*8MPV125	0.98	0.98
EB*2X48L**	MV20L24**B*	0.98	0.98	ED*2X60J**	MV16J22**B*	0.98	0.98	EHD2X60A**	MV16J22**B*	0.98	0.98
EB*2X60J**	*8MPV125	0.98	0.98	ED*2X60J**		1.00	1.00	EHD2X60A**	MV20L24**B*	1.00	1.00
EB*2X60J**	MV16J22**B*	0.98	0.98	ED*2X60L**	MV20L24**B*	0.98	0.98	EHD2X60A**		1.00	1.00
EB*2X60J**		1.00	1.00	ED*2X60L**		1.00	1.00	FEM2X60***		1.00	1.00
EB*2X60L**	MV20L24**B*	0.98	0.98	EHD2X48A**	MV16J22**B*	0.98	0.98	FS(M,U)2X60***		1.00	1.00
ED*2X48J**	MV16J22**B*	0.98	0.98	EHD2X48A**	MV20L24**B*	0.98	0.98	FVM2X60***		1.00	1.00
R2A360											
>EB*2X60L**		1.00	1.00	ED*2X60J**		0.98	0.98	FEM2X60***		1.00	1.00
EB*2X60J**	MV16J22**B*	0.98	0.98	ED*2X60L**		1.00	1.00	FS(M,U)2X60***		0.98	0.98
EB*2X60J**		0.98	0.98	EHD2X60A**	MV16J22**B*	0.98	0.98	FVM2X60***		1.00	1.00
EB*2X60L**	MV20L24**B*	0.98	0.98	EHD2X60A**	MV20L24**B*	0.98	0.98				
ED*2X60J**	MV16J22**B*	0.98	0.98	EHD2X60A**		1.00	1.00				

> Indicates Tested Indoor Model

COOLING Multiplying Factors for other Indoor Combinations

Indoor Model	Capac. (MBh)	Power (AMPS)	Indoor Model	Capac. (MBh)	Power (AMPS)	Indoor Model	Capac. (MBh)	Power (AMPS)
WCA3182								
>W*A*242AA*	1.00	1.00	W*NC182AA*	0.96	0.96	W*NH242BA*	1.00	1.00
W*A*182AA*	0.96	0.96	W*NC242AA*	1.00	1.00	WAH*182A*	0.96	0.88
W*A*242BA*	1.00	1.00	W*NC242BA*	1.00	1.00	WAH*242A*	1.00	0.92
WCA3242								
>W*A*242AA*	1.00	1.00	W*NC242AA*	1.00	1.00	W*NH242BA*	1.00	1.00
W*A*242BA*	1.00	1.00	W*NC242BA*	1.00	1.00	W*NH302BA*	1.00	1.00
W*A*302AA*	1.00	1.00	W*NC302AA*	1.00	1.00	WAH*242A*	1.01	0.92
W*A*302BA*	1.00	1.00	W*NC302BA*	1.00	1.00	WAH*302A*	1.01	0.92
WCA3302								
>W*A*362BA*	1.00	1.00	W*NC302AA*	0.98	0.98	W*NH302BA*	0.98	0.98
W*A*302AA*	0.98	0.98	W*NC302BA*	0.98	0.98	W*NH362BA*	1.00	1.00
W*A*302BA*	0.98	0.98	W*NC362BA*	1.00	1.00	WAH*302A*	0.99	0.99
W*A*362AA*	1.00	1.00	W*NC362CA*	1.00	1.00	WAH*362A*	1.00	1.00
W*A*362CA*	1.00	1.00						
WCA3362								
>W*A*362BA*	1.00	1.00	W*A*422CA*	1.01	1.01	W*NH362BA*	1.00	1.00
W*A*362AA*	0.97	0.97	W*NC362BA*	1.00	1.00	W*NH422CA*	1.01	1.01
W*A*362BA*	1.00	1.00	W*NC362CA*	1.00	1.00	WAH*362A*	1.01	0.97
W*A*362CA*	1.00	1.00	W*NC422CA*	1.01	1.01	WAH*422A*	1.01	0.97
WCA3422								
>W*A*482CA*	1.00	1.00	W*NC482CA*	1.00	1.00	WAH*422A*	0.98	0.98
W*A*482BA*	0.98	0.98	W*NC482DA*	1.00	1.00	WAH*482A*	1.00	1.00
W*A*482DA*	1.00	1.00	W*NH482DA*	1.00	1.00			
WCA3482								
>W*A*602DA*	1.00	1.00	W*NC602DA*	1.00	1.00	WAH*482A*	0.98	0.94
W*A*602CA*	1.00	1.00	W*NH602DA*	1.00	1.00	WAH*602A*	1.00	0.96
WCA3602								
>W*A*602DA*	1.00	1.00	W*NC602DA*	1.00	1.00	WAH*602A*	1.00	0.96
W*A*602CA*	0.98	0.98	W*NH602DA*	1.00	1.00			

NOTE: This illustration is for reference only. Your unit may differ in appearance or may not include all components shown. Please refer to Parts List for exact parts listing.

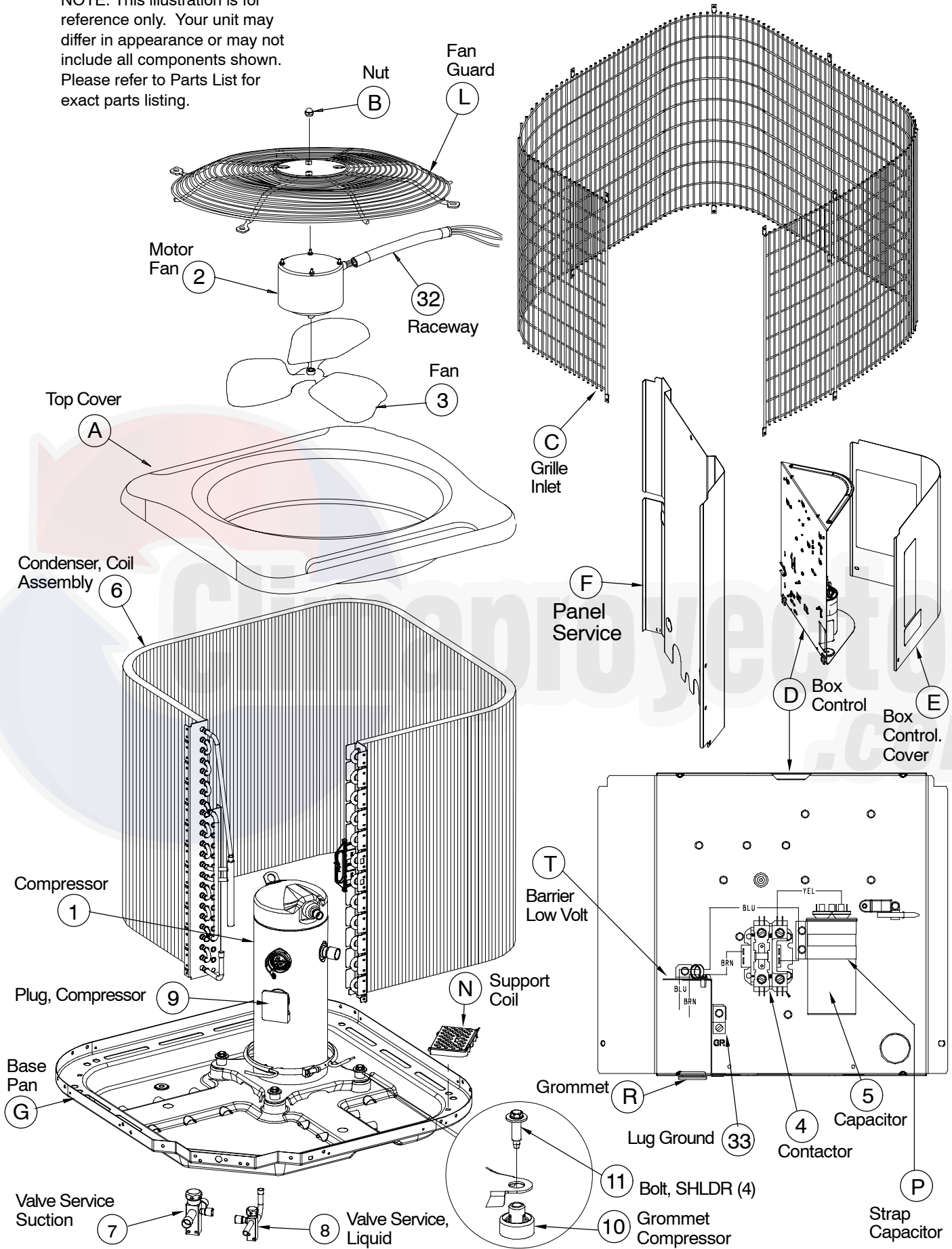

R2AM — 1 Ph PARTS LIST

KEY NO.	DESCRIPTION	PART NO.	R2AM18AKA100	R2AM24AKA100	R2AM30AKA100	R2AM36AKA100	R2AM42AKA100	R2AM48AKA100	R2AM60AKA100
01	COMP ZR16KA-PFV-130	ZR16KAPFV130	1	-	-	-	-	-	-
01	COMP ZR21KA-PFV-130	ZR21KAPFV130	-	1	-	-	-	-	-
01	COMP ZR26KA-PFV-130	ZR26KAPFV130	-	-	1	-	-	-	-
01	COMP ZR32KA-PFV-130	ZR32KAPFV130	-	-	-	1	-	-	-
01	COMP ZR38KA-PFV-130	ZR38KAPFV130	-	-	-	-	1	-	-
01	COMP ZR44KA-PFV-130	ZR44KAPFV130	-	-	-	-	-	1	-
01	COMP ZR54KA-PFV-130	ZR54KAPFV130	-	-	-	-	-	-	1
02	MTR COND 1/230 1/12 1100	1172706	1	1	-	-	-	-	-
02	MTR COND 1/230 1/10 1100	1172707	-	-	1	-	-	-	-
02	MTR COND 1/230 1/5	1172775	-	-	-	1	-	-	-
02	MTR COND 1/230 1/4	1172709	-	-	-	-	1	1	1
03	FAN C 18" 2B 1/2" 23 INT	1172027	1	1	-	-	-	-	-
03	FAN C 18" 3B 1/2" 26 INT	1174760	-	-	1	-	-	-	-
03	FAN C 24" 2B 1/2" 18 INT	1172713	-	-	-	1	-	-	-
03	FAN C 24" 3B 1/2" 19 INT	1173854	-	-	-	-	1	1	1
04	CONTACTOR 1P 30A 24V W/SHUNT	1172472	1	1	1	1	1	1	-
04	CONTACTOR 1P 40A	1176763	-	-	-	-	-	-	1
04	CAP RN RD 370V 5+30	1172109	1	-	-	-	-	-	-
05	CAP RN RD 370V 5+35	1172110	-	1	-	-	-	-	-
05	CAP RN RD 370V 5+45	1172124	-	-	1	-	-	-	-
05	CAP RN RD 370V 5+50	1172111	-	-	-	1	-	-	-
05	CAP RN RD 370V 5+55	1172123	-	-	-	-	1	-	-
05	CAP RN RD 370V 5+60	1172112	-	-	-	-	-	1	-
05	CAP RN RD 370V 5+80	1172113	-	-	-	-	-	-	1
06	COND COIL ASY	1179190	1	-	-	-	-	-	-
06	COND COIL ASY	1179191	-	1	-	-	-	-	-
06	COND COIL ASY	1179192	-	-	1	-	-	-	-
06	COND COIL ASY	1179193	-	-	-	1	-	-	-
06	COND COIL ASY	1179194	-	-	-	-	1	-	-
06	COND COIL ASY	1179195	-	-	-	-	-	1	-
06	COND COIL ASY	1179196	-	-	-	-	-	-	1
07	VALVE SVC PARK SUC 12S-12S	1172726	1	1	1	-	-	-	-
07	VALVE SVC PARK SUC 14S-14S	1172727	-	-	-	1	1	1	1
08	VALVE SVC PARK LIQ 06S-06S	1172792	1	1	1	1	1	1	1
09	PLUG COMP WIRE (SM) 14GAx38"	1172729	1	1	1	-	-	-	-
09	PLUG COMP WIRE (SM) 12GAx38"	1172730	-	-	-	1	1	-	-
09	PLUG COMP WIRE (SM) 12GAx44"	1172731	-	-	-	-	-	1	-
09	PLUG COMP WIRE (SM) 10GAx54"	1172732	-	-	-	-	-	-	1
10	GROMMET COMPRESSOR 1.62"DIA	1171270	4	4	4	4	4	4	4
11	BOLT COMPRESSOR	1179201	4	4	4	4	4	4	4
32	RACEWAY CARFLEX 7.5"	1174769	1	1	1	-	-	-	-
32	RACEWAY	1171428	-	-	-	1	1	1	1
33	LUG GROUND	1172300	1	1	1	1	1	1	1
A	TOP COVER ASSY	1176739	1	1	1	-	-	-	-
A	TOP COVER ASSY	1176738	-	-	-	1	1	1	1
B	NUT CAP HEX	1172740	4	4	4	4	4	4	4
C	INLET GRILLE MINI	1177079	1	-	-	-	-	-	-
C	INLET GRILLE MINI	1177080	-	1	1	-	-	-	-
C	INLET GRILLE MEDIUM	1177081	-	-	-	1	-	-	-

R2AM — 1 Ph PARTS LIST (continued)									
KEY NO.	DESCRIPTION	PART NO.	R2AM18AKA100	R2AM24AKA100	R2AM30AKA100	R2AM36AKA100	R2AM42AKA100	R2AM48AKA100	R2AM60AKA100
C	INLET GRILLE MEDIUM	1177082	-	-	-	-	1	-	-
C	INLET GRILLE MEDIUM	1177084	-	-	-	-	-	1	-
C	INLET GRILLE MEDIUM	1177083	-	-	-	-	-	-	1
D	BOX CONTROL	1179198	1	1	1	1	1	1	1
E	KIT CONTROL BOX COVER	1179197	1	1	1	1	1	1	1
F	SERVICE PANEL	1176740	1	-	-	1	-	-	-
F	SERVICE PANEL	1176741	-	1	1	-	-	-	-
F	SERVICE PANEL	1176742	-	-	-	-	1	-	-
F	SERVICE PANEL	1176744	-	-	-	-	-	1	-
F	SERVICE PANEL	1176743	-	-	-	-	-	-	1
G	BASE PAN ASSY	1176737	1	1	1	-	-	-	-
G	BASE PAN	1176764	-	-	-	1	1	1	1
L	GUARD FAN	1179199	1	1	1	-	-	-	-
L	GUARD FAN	1179200	-	-	-	1	1	1	1
N	SUPPORT COIL	1174068	3	3	3	5	5	5	5
P	CLAMP CAPACITOR ROUND 2.0"D	1172734	1	1	1	1	-	-	-
P	CLAMP CAPACITOR ROUND 2.5"D	1172735	-	-	-	-	1	1	1
R	GROMMET	1171737	1	1	1	1	1	1	1
T	BARRIER LOW VOLTAGE	1176762	1	1	1	1	1	1	1
Parts Not Shown									
)	CAP SERVICE KIT 11/16-20	1175650	1	1	1	1	1	1	1
)	CAP SERVICE KIT 15/16-20	1175651	1	1	1	1	-	-	-
)	CAP SERVICE KIT 1-1/16-20	1175652	-	-	-	-	1	1	1
)	DISTRIBUTOR	1172021	-	-	-	-	1	-	-
)	DISTRIBUTOR	1172022	-	-	-	-	-	1	-
)	DISTRIBUTOR	1173667	-	-	-	-	-	-	1
)	PAINT TOUCH UP 1 PT DARK GRAY	1174762	1	1	1	1	1	1	1
)	SCREW 10 X 1/2 25 PACK	1174880	1	1	1	1	1	1	1
)	SCREW HEX HD 10AB X 3/8	1176782	10	10	10	10	10	10	10
)	SCREW HEX HD 12AB X 5/8	1176781	4	4	4	4	4	4	4

R2AM — 3Ph PARTS LIST

KEY NO.	DESCRIPTION	PART NO.	R2AM36AHA100	R2AM48AHA100	R2AM60AHA100
01	COMP ZR32KA-TF5-130	ZR32KATF5130	1	-	-
01	COMP ZR44KA-TF5-130	ZR44KATF5130	-	1	-
01	COMP ZR54KA-TF5-130	ZR54KATF5130	-	-	1
02	MTR CND 1/230 1/5	1172775	1	-	-
02	MTR CND 1/230 1/4	1172709	-	1	1
03	FAN C 24" 2B 1/2" 18 INT	1172713	1	-	-
03	FAN C 24" 3B 1/2" 19 INT	1173854	-	1	1
04	CONTACTOR 2P 30A 24V	1173785	1	1	1
05	CAP RN OV 370V 5	1171727	1	1	1
06	COND COIL ASY	1179193	1	-	-
06	COND COIL ASY	1179195	-	1	-
06	COND COIL ASY	1179196	-	-	1
07	VALVE SVC PARK SUC 14S-14S	1172727	1	1	1
08	VALVE SVC PARK LIQ 06S-06S	1172792	1	1	1
09	PLUG COMPRESSOR 3PH MONITOR	1174072	1	-	-
09	PLUG COMPRESSOR 3PH MONITOR	1174082	-	1	1
10	GROMMET COMPRESSOR 1.62"DIA	1171270	4	4	4
11	BOLT COMPRESSOR	1179201	4	4	4
32	RACEWAY	1171428	1	1	1
33	LUG GROUND	1172300	1	1	1
34	RELAY PHASE MONITOR	1173408	1	1	1
35	HTR CC WP 40W240V	1172358	-	-	1
36	SWITCH TEMP DISC O85 C65	1172359	-	-	1
A	TOP COVER ASSY	1176738	1	1	1
B	NUT CAP HEX	1172740	4	4	4
C	INLET GRILLE MEDIUM	1177081	1	-	-
C	INLET GRILLE MEDIUM	1177084	-	1	-
C	INLET GRILLE MEDIUM	1177083	-	-	1
D	BOX CONTROL	1179207	1	1	1
E	KIT CONTROL BOX COVER	1179208	1	1	1
F	SERVICE PANEL	1176740	1	-	-
F	SERVICE PANEL	1176744	-	1	-
F	SERVICE PANEL	1176743	-	-	1
G	BASE PAN	1176764	1	1	1
L	GUARD FAN	1179200	1	1	1
N	SUPPORT COIL	1174068	5	5	5
P	STRAP CAPACITOR	1174073	1	1	1
R	GROMMET	1171737	1	1	1
T	BARRIER LOW VOLTAGE	1176762	1	1	1
Parts Not Shown					
)	CAP SERVICE KIT 11/16-20	1175650	1	1	1
)	CAP SERVICE KIT 15/16-20	1175651	1	-	-
)	CAP SERVICE KIT 1-1/16-20	1175652	-	1	1
)	DISTRIBUTOR	1172022	-	1	-
)	DISTRIBUTOR	1173667	-	-	1
)	PAINT TOUCH UP 1 PT DARK GRAY	1174762	1	1	1
)	SCREW 10 X 1/2 25 PACK	1174880	1	1	1
)	SCREW HEX HD 10AB X 3/8	1176782	10	10	10
)	SCREW HEX HD 12AB X 5/8	1176781	4	4	4

R2A3 PARTS LIST																
KEY NO.	DESCRIPTION	PART NO.	R2A318AKC100	R2A318GKC100	R2A324AKC100	R2A324GKC100	R2A330AKC100	R2A330GKC100	R2A336AKC100	R2A336GKC100	R2A342AKC100	R2A342GKC100	R2A348AKC100	R2A348GKC100	R2A360AKC100	R2A360GKC100
01	COMPRESSOR	ZR16KAPFV130	1	1	-	-	-	-	-	-	-	-	-	-	-	-
01	COMPRESSOR	ZR21KAPFV130	-	-	1	1	-	-	-	-	-	-	-	-	-	-
01	COMPRESSOR	ZR26KAPFV130	-	-	-	-	1	1	-	-	-	-	-	-	-	-
01	COMPRESSOR	ZR32KAPFV130	-	-	-	-	-	-	1	1	-	-	-	-	-	-
01	COMPRESSOR	ZR38KAPFV130	-	-	-	-	-	-	-	-	1	1	-	-	-	-
01	COMPRESSOR	ZR44KAPFV130	-	-	-	-	-	-	-	-	-	-	1	1	-	-
01	COMPRESSOR	ZR54KAPFV130	-	-	-	-	-	-	-	-	-	-	-	-	1	1
02	MOTOR CONDENSER FAN	1172706	1	1	1	1	-	-	-	-	-	-	-	-	-	-
02	MOTOR CONDENSER FAN	1172707	-	-	-	-	1	1	-	-	-	-	-	-	-	-
02	MOTOR CONDENSER FAN	1172775	-	-	-	-	-	-	1	1	-	-	-	-	-	-
02	MOTOR CONDENSER FAN	1172709	-	-	-	-	-	-	-	-	1	1	1	1	1	1
03	FAN BLADE	1172027	1	1	1	1	-	-	-	-	-	-	-	-	-	-
03	FAN BLADE	1174760	-	-	-	-	1	1	-	-	-	-	-	-	-	-
03	FAN BLADE	1172713	-	-	-	-	-	-	1	1	-	-	-	-	-	-
03	FAN BLADE	1173854	-	-	-	-	-	-	-	-	1	1	1	1	1	1
04	CONTACTOR 30 AMP	1172472	1	1	1	1	1	1	1	1	1	1	1	1	-	-
04	CONTACTOR 40AMP	1176763	-	-	-	-	-	-	-	-	-	-	-	-	1	1
04	CAPACITOR 370V 30+5 MFD	1172109	1	1	-	-	-	-	-	-	-	-	-	-	-	-
05	CAPACITOR 370V 35+5 MFD	1172110	-	-	1	1	-	-	-	-	-	-	-	-	-	-
05	CAPACITOR 370V 45+5 MFD	1172124	-	-	-	-	1	1	-	-	-	-	-	-	-	-
05	50+5 MFD 370V	1172111	-	-	-	-	-	-	1	1	-	-	-	-	-	-
05	55+5 MFD 370V	1172123	-	-	-	-	-	-	-	-	1	1	-	-	-	-
05	60+5 MFD 370V	1172112	-	-	-	-	-	-	-	-	-	-	1	1	-	-
05	80+5 MFD 370V	1172113	-	-	-	-	-	-	-	-	-	-	-	-	1	1
06	KIT CONDENSER COIL	1176754	1	1	-	-	-	-	-	-	-	-	-	-	-	-
06	KIT CONDENSER COIL	1176755	-	-	1	1	-	-	-	-	-	-	-	-	-	-
06	KIT CONDENSER COIL	1176756	-	-	-	-	1	1	-	-	-	-	-	-	-	-
06	KIT CONDENSER COIL	1176757	-	-	-	-	-	-	1	1	-	-	-	-	-	-
06	KIT CONDENSER COIL	1176758	-	-	-	-	-	-	-	-	1	1	-	-	-	-
06	KIT CONDENSER COIL	1176759	-	-	-	-	-	-	-	-	-	-	1	1	-	-
06	KIT CONDENSER COIL	1176760	-	-	-	-	-	-	-	-	-	-	-	-	1	1
07	SERVICE VALVE SUCTION	1172726	1	1	1	1	1	1	-	-	-	-	-	-	-	-
07	SERVICE VALVE SUCTION	1172727	-	-	-	-	-	-	1	1	1	1	1	1	1	1
08	SERVICE VALVE LIQUID	1172792	1	1	1	1	1	1	1	1	1	1	1	1	1	1
09	PLUG COMPRESSOR HARNESS	1172729	1	1	1	1	1	1	-	-	-	-	-	-	-	-
09	PLUG COMPRESSOR HARNESS	1172730	-	-	-	-	-	-	1	1	-	1	-	-	-	-
09	PLUG COMPRESSOR HARNESS	1172731	-	-	-	-	-	-	-	-	-	-	1	1	-	-
09	PLUG COMPRESSOR HARNESS	1174780	-	-	-	-	-	-	-	-	1	-	-	-	-	-
09	PLUG COMPRESSOR HARNESS	1172732	-	-	-	-	-	-	-	-	-	-	-	-	1	1
10	GROMMET COMPRESSOR	1171270	4	4	4	4	4	4	4	4	4	4	4	4	4	4
11	BOLT COMPRESSOR MOUNTING	1173630	4	4	4	4	4	4	4	4	4	4	4	4	4	4
32	RACEWAY	1174769	1	1	1	1	1	1	-	-	-	-	-	-	-	-
32	RACEWAY	1171428	-	-	-	-	-	-	1	1	1	1	1	1	1	1
33	LUG GROUND	1172300	1	1	1	1	1	1	1	1	1	1	1	1	1	1
A	PANEL TOP	1176739	1	1	1	1	1	1	-	-	-	-	-	-	-	-
A	PANEL TOP	1176738	-	-	-	-	-	-	1	1	1	1	1	1	1	1
B	NUT HEX	1172740	4	4	4	4	4	4	4	4	4	4	4	4	4	4
C	GRILLE INLET	1176985		1	-	-	-	-	-	-	-	-	-	-	-	-

- continued on next page -

R2A3 PARTS LIST (continued)															
KEY NO.	DESCRIPTION	PART NO.	R2A318AKC100	R2A318GKC100	R2A324AKC100	R2A324GKC100	R2A330AKC100	R2A330GKC100	R2A336AKC100	R2A336GKC100	R2A342AKC100	R2A342GKC100	R2A348AKC100	R2A348GKC100	R2A360AKC100
C	GRILLE INLET	1177079	1	-	-	-	-	-	-	-	-	-	-	-	-
C	GRILLE INLET	1176986	-	-	-	1	-	1	-	-	-	-	-	-	-
C	GRILLE INLET	1177080	-	-	1	-	1	-	-	-	-	-	-	-	-
C	GRILLE INLET	1176987	-	-	-	-	-	-	-	1	-	-	-	-	-
C	GRILLE INLET	1177081	-	-	-	-	-	-	1	-	-	-	-	-	-
C	GRILLE INLET	1176989	-	-	-	-	-	-	-	-	-	1	-	-	-
C	GRILLE INLET	1177082	-	-	-	-	-	-	-	-	1	-	-	-	-
C	GRILLE INLET	1176991	-	-	-	-	-	-	-	-	-	-	-	1	-
C	GRILLE INLET	1177084	-	-	-	-	-	-	-	-	-	-	1	-	-
C	GRILLE INLET	1176993	-	-	-	-	-	-	-	-	-	-	-	-	1
C	GRILLE INLET	1177083	-	-	-	-	-	-	-	-	-	-	-	-	1
D	BOX CONTROL	1176761	1	1	1	1	1	1	1	1	1	1	1	1	1
E	KIT COVER CONTROL BOX	1176753	1	1	1	1	1	1	1	1	1	1	1	1	1
F	PANEL SERVICE	1176740	1	1	-	-	-	-	-	1	-	-	-	-	-
F	PANEL SERVICE	1176741	-	-	1	1	1	1	1	-	-	-	-	-	-
F	PANEL SERVICE	1176742	-	-	-	-	-	-	-	-	1	1	-	-	-
F	PANEL SERVICE	1176744	-	-	-	-	-	-	-	-	-	-	1	1	-
F	PANEL SERVICE	1176743	-	-	-	-	-	-	-	-	-	-	-	-	1
G	PAN BASE	1176737	1	1	1	1	1	1	-	-	-	-	-	-	-
G	PAN BASE	1176764	-	-	-	-	-	-	1	1	1	1	1	1	1
L	GUARD FAN	1176745	1	1	1	1	1	1	-	-	-	-	-	-	-
L	GUARD FAN	1176746	-	-	-	-	-	-	1	1	1	1	1	1	1
N	SUPPORT COIL	1174068	3	3	3	3	3	3	5	5	5	5	5	5	5
P	STRAP CAPACITOR	1172734	1	1	1	1	1	1	1	1	-	-	-	-	-
P	STRAP CAPACITOR	1172735	-	-	-	-	-	-	-	-	1	1	1	1	1
R	GROMMET	1171737	1	1	1	1	1	1	1	1	1	1	1	1	1
T	BARRIER LOW VOLTAGE	1176762	1	1	1	1	1	1	1	1	1	1	1	1	1
Parts Not Shown															
)	CAP SERVICE KIT 11/16-20	1175650	1	1	1	1	1	1	1	1	1	1	1	1	1
)	CAP SERVICE KIT 15/16-20	1175651	1	1	1	1	1	1	1	1	-	-	-	-	-
)	CAP SERVICE KIT 1-1/16-20	1175652	-	-	-	-	-	-	-	-	1	1	1	1	1
)	DISTRUBITOR	1172021	-	-	-	-	-	-	-	-	1	1	-	-	-
)	DISTRUBITOR	1172022	-	-	-	-	-	-	-	-	-	-	1	1	-
)	DISTRUBITOR	1173667	-	-	-	-	-	-	-	-	-	-	-	-	1
)	PAINT TOUCH UP 1PT	1174762	1	1	1	1	1	1	1	1	1	1	1	1	1
)	SCREW 10 X 1/2 25 PACK	1174880	1	1	1	1	1	1	1	1	1	1	1	1	1
)	SCREW HEX HD 10AB 3/8	1176782	10	10	10	10	10	10	10	10	10	10	10	10	10
)	SCREW HEX HD 12AB 5/8	1176781	4	4	4	4	4	4	4	4	4	4	4	4	4
)	Manual, Installation	42101520200	1	1	1	1	1	1	1	1	1	1	1	1	1
)	Manual, Owner's	42102500000	1	1	1	1	1	1	1	1	1	1	1	1	1
)	Warranty Card	40106403503	1	1	1	1	1	1	1	1	1	1	1	1	1

WCA3**2 PARTS LIST									
KEY NO.	DESCRIPTION	PART NO.	WCA3182GKA1	WCA3242GKA1	WCA3302GKA1	WCA3362GKA1	WCA3422GKA1	WCA3482GKA1	WCA3602GKA1
01	COMPRESSOR	ZR16KAPFV130	1	-	-	-	-	-	-
01	COMPRESSOR	ZR21KAPFV130	-	1	-	-	-	-	-
01	COMPRESSOR	ZR26KAPFV130	-	-	1	-	-	-	-
01	COMPRESSOR	ZR32KAPFV130	-	-	-	1	-	-	-
01	COMPRESSOR	ZR38KAPFV130	-	-	-	-	1	-	-
01	COMPRESSOR	ZR44KAPFV130	-	-	-	-	-	1	-
01	COMPRESSOR	ZR54KAPFV130	-	-	-	-	-	-	1
02	MOTOR CONDENSER FAN	1172706	1	1	-	-	-	-	-
02	MOTOR CONDENSER FAN	1172707	-	-	1	-	-	-	-
02	MOTOR CONDENSER FAN	1172775	-	-	-	1	-	-	-
02	MOTOR CONDENSER FAN	1172709	-	-	-	-	1	1	1
03	FAN BLADE	1172027	1	1	-	-	-	-	-
03	FAN BLADE	1174760	-	-	1	-	-	-	-
03	FAN BLADE	1172713	-	-	-	1	-	-	-
03	FAN BLADE	1173854	-	-	-	-	1	1	1
04	CONTACTOR 30 AMP	1172472	1	1	1	1	1	1	-
04	CONTACTOR 40AMP	1176763	-	-	-	-	-	-	1
04	CAPACITOR 370V 30+5 MFD	1172109	1	-	-	-	-	-	-
05	CAPACITOR 370V 35+5 MFD	1172110	-	1	-	-	-	-	-
05	CAPACITOR 370V 45+5 MFD	1172124	-	-	1	-	-	-	-
05	50+5 MFD 370V	1172111	-	-	-	1	-	-	-
05	55+5 MFD 370V	1172123	-	-	-	-	1	-	-
05	60+5 MFD 370V	1172112	-	-	-	-	-	1	-
05	80+5 MFD 370V	1172113	-	-	-	-	-	-	1
06	KIT CONDENSER COIL	1176754	1	-	-	-	-	-	-
06	KIT CONDENSER COIL	1176755	-	1	-	-	-	-	-
06	KIT CONDENSER COIL	1176756	-	-	1	-	-	-	-
06	KIT CONDENSER COIL	1176757	-	-	-	1	-	-	-
06	KIT CONDENSER COIL	1176758	-	-	-	-	1	-	-
06	KIT CONDENSER COIL	1176759	-	-	-	-	-	1	-
06	KIT CONDENSER COIL	1176760	-	-	-	-	-	-	1
07	SERVICE VALVE SUCTION	1172726	1	1	1	-	-	-	-
07	SERVICE VALVE SUCTION	1172727	-	-	-	1	1	1	1
08	SERVICE VALVE LIQUID	1172792	1	1	1	1	1	1	1
09	PLUG COMPRESSOR HARNESS	1172729	1	1	1	-	-	-	-
09	PLUG COMPRESSOR HARNESS	1172730	-	-	-	1	1	-	-
09	PLUG COMPRESSOR HARNESS	1172731	-	-	-	-	-	1	-
09	PLUG COMPRESSOR HARNESS	1172732	-	-	-	-	-	-	1
10	GROMMET COMPRESSOR	1171270	4	4	4	4	4	4	4
11	BOLT COMPRESSOR MOUNTING	1173630	4	4	4	4	4	4	4
32	RACEWAY	1174769	1	1	1	-	-	-	-
32	RACEWAY	1171428	-	-	-	1	1	1	1
33	LUG GROUND	1172300	1	1	1	1	1	1	1
A	PANEL TOP	1176739	1	1	1	-	-	-	-
A	PANEL TOP	1176738	-	-	-	1	1	1	1
B	NUT HEX	1172740	4	4	4	4	4	4	4
C	GRILLE INLET	1176985	1	-	-	-	-	-	-
C	GRILLE INLET	1176986	-	1	1	-	-	-	-

- continued on next page -

WCA3**2 PARTS LIST (continued)									
KEY NO.	DESCRIPTION	PART NO.	WCA3182GKA1	WCA3242GKA1	WCA3302GKA1	WCA3362GKA1	WCA3422GKA1	WCA3482GKA1	WCA3602GKA1
C	GRILLE INLET	1176987	-	-	-	1	-	-	-
C	GRILLE INLET	1176989	-	-	-	-	1	-	-
C	GRILLE INLET	1176991	-	-	-	-	-	1	-
C	GRILLE INLET	1176993	-	-	-	-	-	-	1
D	BOX CONTROL	1176761	1	1	1	1	1	1	1
E	KIT COVER CONTROL BOX	1176753	1	1	1	1	1	1	1
F	PANEL SERVICE	1176740	1	-	-	1	-	-	-
F	PANEL SERVICE	1176741	-	1	1	-	-	-	-
F	PANEL SERVICE	1176742	-	-	-	-	1	-	-
F	PANEL SERVICE	1176744	-	-	-	-	-	1	-
F	PANEL SERVICE	1176743	-	-	-	-	-	-	1
G	PAN BASE	1176737	1	1	1	-	-	-	-
G	PAN BASE	1176764	-	-	-	1	1	1	1
L	GUARD FAN	1176745	1	1	1	-	-	-	-
L	GUARD FAN	1176746	-	-	-	1	1	1	1
N	SUPPORT COIL	1174068	3	3	3	5	5	5	5
P	STRAP CAPACITOR	1172734	1	1	1	1	-	-	-
P	STRAP CAPACITOR	1172735	-	-	-	-	1	1	1
R	GROMMET	1171737	1	1	1	1	1	1	1
T	BARRIER LOW VOLTAGE	1176762	1	1	1	1	1	1	1
Parts Not Shown									
)	CAP SERVICE KIT 11/16-20	1175650	1	1	1	1	1	1	1
)	CAP SERVICE KIT 15/16-20	1175651	1	1	1	1	-	-	-
)	CAP SERVICE KIT 1-1/16-20	1175652	-	-	-	-	1	1	1
)	DISTRUBITOR	1172021	-	-	-	-	1	-	-
)	DISTRUBITOR	1172022	-	-	-	-	-	1	-
)	DISTRUBITOR	1173667	-	-	-	-	-	-	1
)	PAINT TOUCH UP 1PT	1174762	1	1	1	1	1	1	1
)	SCREW 10 X 1/2 25 PACK	1174880	1	1	1	1	1	1	1
)	SCREW HEX HD 10AB 3/8	1176782	10	10	10	10	10	10	10
)	SCREW HEX HD 12AB 5/8	1176781	4	4	4	4	4	4	4
)	Manual, Installation	42101520200	1	1	1	1	1	1	1
)	Manual, Owner's	42102500000	1	1	1	1	1	1	1
)	Warranty Card	40106410000	1	1	1	1	1	1	1