



Mission ON-OFF SERIES

Service Manual 2015

MBSSA-A-1501



CONTENTS

| | |
|--|-----------|
| 1. Precaution | 3 |
| 1.1 Safety Precaution..... | 3 |
| 1.2 Warning | 3 |
| 2. Function | 6 |
| 3. Dimension | 7 |
| 3.1 Indoor Unit..... | 7 |
| 3.2 Outdoor Unit..... | 9 |
| 4. Refrigerant Cycle Diagram | 10 |
| 5 Installation Details | 12 |
| 5.1 Wrench torque sheet for installation | 12 |
| 5.2 Connecting the cables | 12 |
| 5.3 Pipe length and the elevation | 13 |
| 5.4 Installation for the first time | 14 |
| 5.5 Adding the refrigerant after running the system for many years | 15 |
| 5.6 Re-installation while the indoor unit need to be repaired | 16 |
| 5.7 Re-installation while the outdoor unit need to be repaired | 17 |
| 6. Operation Characteristics | 18 |
| 7. Electronic function | 19 |
| 7.1 Abbreviation | 19 |
| 7.2 Display function..... | 19 |
| 7.3 Main Protection | 20 |
| 7.4 Operation Modes and Functions..... | 20 |
| 8. Troubleshooting | 24 |
| 8.1 Indoor Unit Error Display..... | 24 |
| 8.2 Diagnosis and Solution | 25 |

1. Precaution

1.1 Safety Precaution

- To prevent injury to the user or other people and property damage, the following instructions must be followed.

- Incorrect operation due to ignoring instruction will cause harm or damage.

- Before service the unit, be sure to read this service manual at first.

1.2 Warning

➤ Installation

- Do not use a defective or underrated circuit breaker. Use this appliance on a dedicated circuit.

There is risk of fire or electric shock.

- For electrical work, contact the dealer, seller, a qualified electrician, or an authorized service center.

Do not disassemble or repair the product, there is risk of fire or electric shock.

- Always ground the product.

There is risk of fire or electric shock.

- Install the panel and the cover of control box securely.

There is risk of fire of electric shock.

- Always install a dedicated circuit and breaker.

Improper wiring or installation may cause fire or electric shock.

- Use the correctly rated breaker of fuse.

There is risk of fire or electric shock.

- Do not modify or extend the power cable.

There is risk of fire or electric shock.

- Do not install, remove, or reinstall the unit by yourself (customer).

There is risk of fire, electric shock, explosion, or injury.

- Be caution when unpacking and installing the product.

Sharp edges could cause injury, be especially

careful of the case edges and the fins on the condenser and evaporator.

- For installation, always contact the dealer or an authorized service center.

- Do not install the product on a defective installation stand.

- Be sure the installation area does not deteriorate with age.

If the base collapses, the air conditioner could fall with it, causing property damage, product failure, and personal injury.

- Do not let the air conditioner run for a long time when the humidity is very high and a door or a window is left open.

- Take care to ensure that power cable could not be pulled out or damaged during operation.

There is risk of fire or electric shock.

- Do not place anything on the power cable.

There is risk of fire or electric shock.

- Do not plug or unplug the power supply plug during operation.

There is risk of fire or electric shock.

- Do not touch (operation) the product with wet hands.

- Do not place a heater or other appliance near the power cable.

There is risk of fire and electric shock.

- Do not allow water to run into electrical parts.

It may cause fire, failure of the product, or electric shock.

- Do not store or use flammable gas or combustible near the product.

There is risk of fire or failure of product.

- Do not use the product in a tightly closed space for a long time.

Oxygen deficiency could occur.

- When flammable gas leaks, turn off the gas and open a window for ventilation before turn the product on.

- If strange sounds or smoke comes from product, turn the breaker off or disconnect the power supply cable.

There is risk of electric shock or fire.

- **Stop operation and close the window in storm or hurricane. If possible, remove the product from the window before the hurricane arrives.**

There is risk of property damage, failure of product, or electric shock.

- **Do not open the inlet grill of the product during operation. (Do not touch the electrostatic filter, if the unit is so equipped.)**

There is risk of physical injury, electric shock, or product failure.

- **When the product is soaked, contact an authorized service center.**

There is risk of fire or electric shock.

- **Be caution that water could not enter the product.**

There is risk of fire, electric shock, or product damage.

- **Ventilate the product from time to time when operating it together with a stove etc.**

There is risk of fire or electric shock.

- **Turn the main power off when cleaning or maintaining the product.**

There is risk of electric shock.

- **When the product is not be used for a long time, disconnect the power supply plug or turn off the breaker.**

There is risk of product damage or failure, or unintended operation.

- **Take care to ensure that nobody could step on or fall onto the outdoor unit.**

This could result in personal injury and product damage.

➤ **CAUTION**

- **Always check for gas (refrigerant) leakage after installation or repair of product.**

Low refrigerant levels may cause failure of product.

- **Install the drain hose to ensure that water is drained away properly.**

A bad connection may cause water leakage.

- **Keep level even when installing the product.**

It can avoid vibration of water leakage.

- **Do not install the product where the noise or hot air from the outdoor unit could damage the neighborhoods.**

It may cause a problem for your neighbors.

- **Use two or more people to lift and transport the product.**

- **Do not install the product where it will be exposed to sea wind (salt spray) directly.**

It may cause corrosion on the product.

Corrosion, particularly on the condenser and evaporator fins, could cause product malfunction or inefficient operation.

➤ **Operational**

- **Do not expose the skin directly to cool air for long time. (Do not sit in the draft).**

- **Do not use the product for special purposes, such as preserving foods, works of art etc. It is a consumer air conditioner, not a precision refrigerant system.**

There is risk of damage or loss of property.

- **Do not block the inlet or outlet of air flow.**

- **Use a soft cloth to clean. Do not use harsh detergents, solvents, etc.**

There is risk of fire, electric shock, or damage to the plastic parts of the product.

- **Do not touch the metal parts of the product when removing the air filter. They are very sharp.**

- **Do not step on or put anything on the product. (outdoor units)**

- **Always insert the filter securely.**

Clean the filter every two weeks or more often if necessary.

A dirty filter reduces the efficiency of the air conditioner and could cause product malfunction or damage.

- **Do not insert hands or other objects through air inlet or outlet while the product is operated.**

- **Do not drink the water drained from the product.**

- **Use a firm stool or ladder when**

cleaning or maintaining the product.

Be careful and avoid personal injury.

■ **Replace the all batteries in the remote control with new ones of the same type. Do not mix old and new batteries or different types of batteries.**

There is risk of fire or explosion.

■ **Do not recharge or disassemble the batteries. Do not dispose of batteries in a fire.**

They may burn or explode.

■ **If the liquid from the batteries gets onto your skin or clothes, wash it well with clean water. Do not use the remote if the batteries have leaked.**



2. Function

Model Names of Indoor/Outdoor Units

| | Capacity | Indoor units | Outdoor units |
|--------|----------|-----------------|---------------|
| On-Off | 12k | MSMBB-12CR-BB8 | MOA2-12C-BB8 |
| | 12k | MSMBB-12HR-BB8 | MOA1-12H-BB8 |
| | 12k | MSMBB-12CR-NB8 | MOB3-12C-NB8 |
| | 12k | MSMBB-12HR-NB8 | MOB3-12H-NB8 |
| | 17k | MSMBC-17CR-NB8 | MOB2-17C-NB8 |
| | 17k | MSMBC-17HR-NB8 | MOB1-17H-NB8 |
| | 21k | MSMBD-21CR-NB8W | MOF3-21C-NB8W |
| | 21k | MSMBD-21HR-NB8W | MOF2-21H-NB8W |



3. Dimension

3.1 Indoor Unit

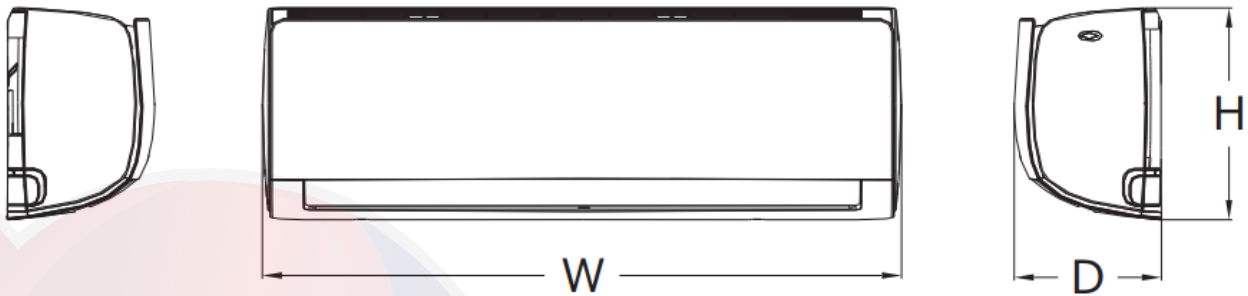
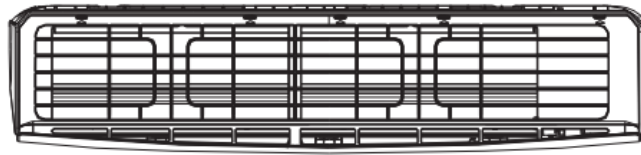

| Model | W | D | H |
|-----------------|------|-----|-----|
| MSMBB-12CR-BB8 | 810 | 200 | 300 |
| MSMBB-12HR-BB8 | 810 | 200 | 300 |
| MSMBB-12CR-NB8 | 810 | 200 | 300 |
| MSMBB-12HR-NB8 | 810 | 200 | 300 |
| MSMBC-17CR-NB8 | 980 | 225 | 325 |
| MSMBC-17HR-NB8 | 980 | 225 | 325 |
| MSMBD-21CR-NB8W | 1090 | 235 | 338 |
| MSMBD-21HR-NB8W | 1090 | 235 | 338 |

For MSMBB-12CR-BB8, MSMBB-12HR-BB8, MSMBB-12CR-NB8, MSMBB-12HR-NB8,

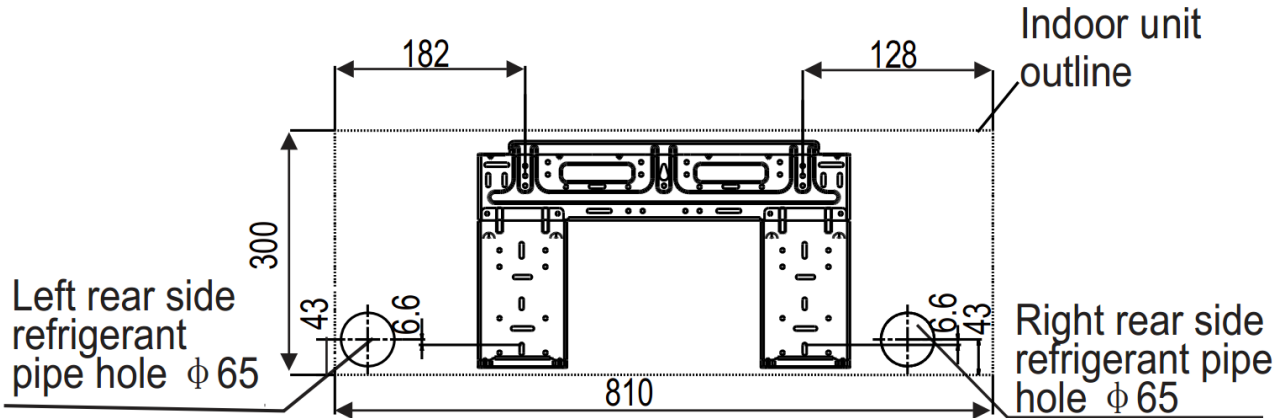

For MSMBB-17CR-NB8, MSMBB-17HR-NB8,

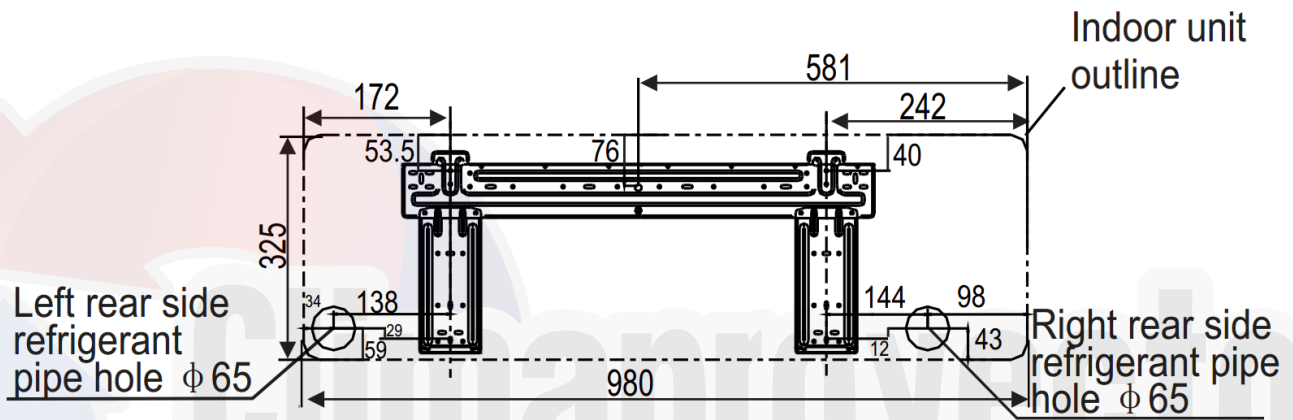

For MSMBD-21CR-NB8W, MSMBD-21HR-NB8W,

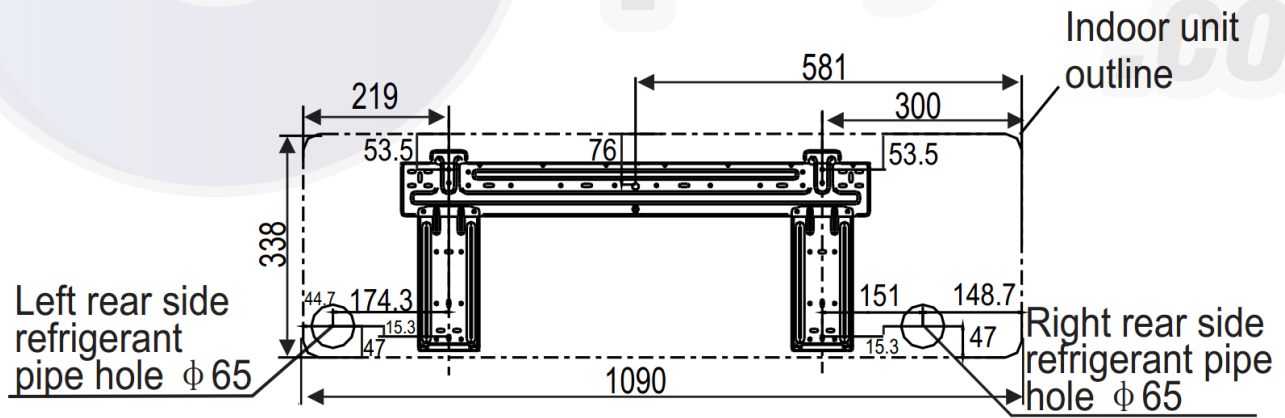

3.2 Outdoor Unit

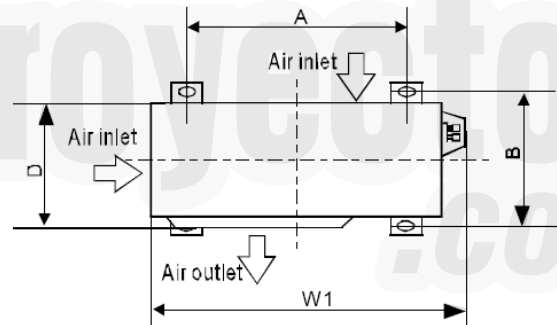
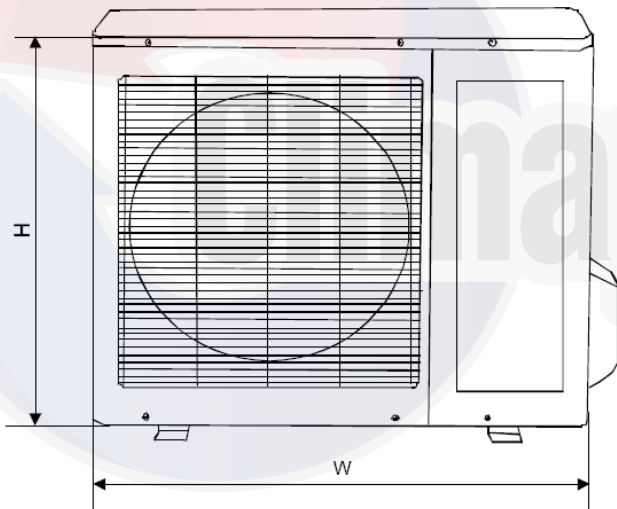
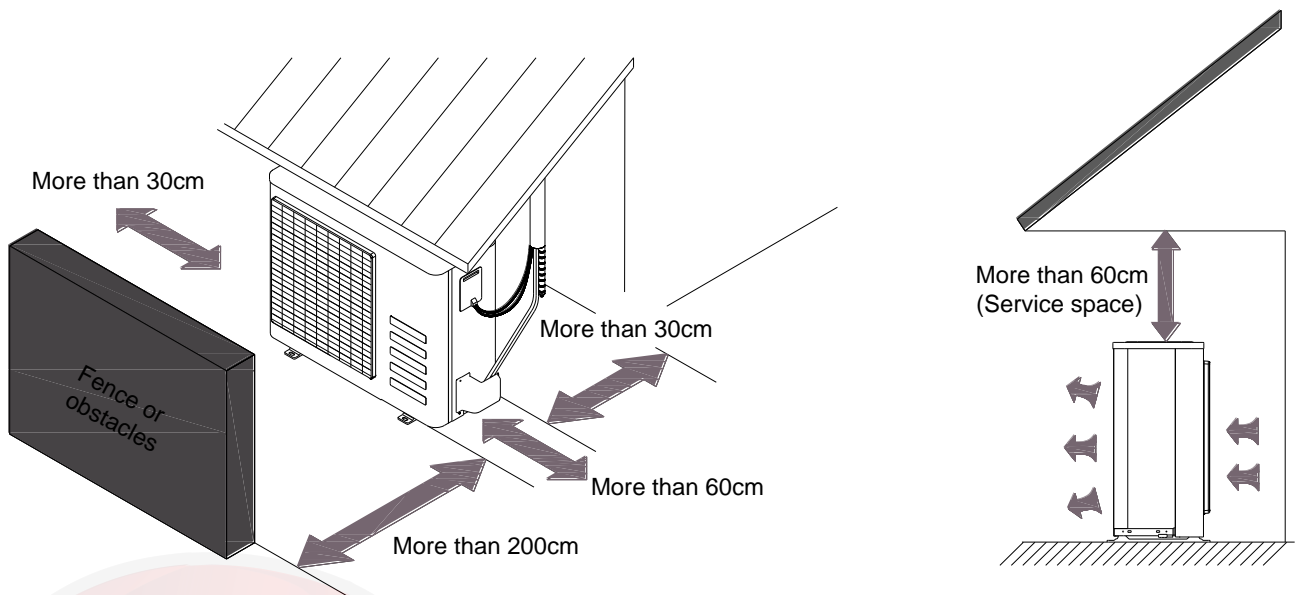

| Model | W | D | H | W1 | A | B |
|---------------|-----|-----|-----|-----|-----|-----|
| MOA2-12C-BB8 | 700 | 240 | 540 | 757 | 458 | 250 |
| MOA1-12H-BB8 | 700 | 240 | 540 | 757 | 458 | 250 |
| MOB3-12C-NB8 | 780 | 250 | 540 | 843 | 549 | 276 |
| MOB3-12H-NB8 | 780 | 250 | 540 | 843 | 549 | 276 |
| MOB2-17C-NB8 | 780 | 250 | 540 | 843 | 549 | 276 |
| MOB1-17H-NB8 | 780 | 250 | 540 | 843 | 549 | 276 |
| MOF3-21C-NB8W | 845 | 320 | 700 | 908 | 560 | 335 |
| MOF2-21H-NB8W | 845 | 320 | 700 | 908 | 560 | 335 |

4. Refrigerant Cycle Diagram

For cooling only models:

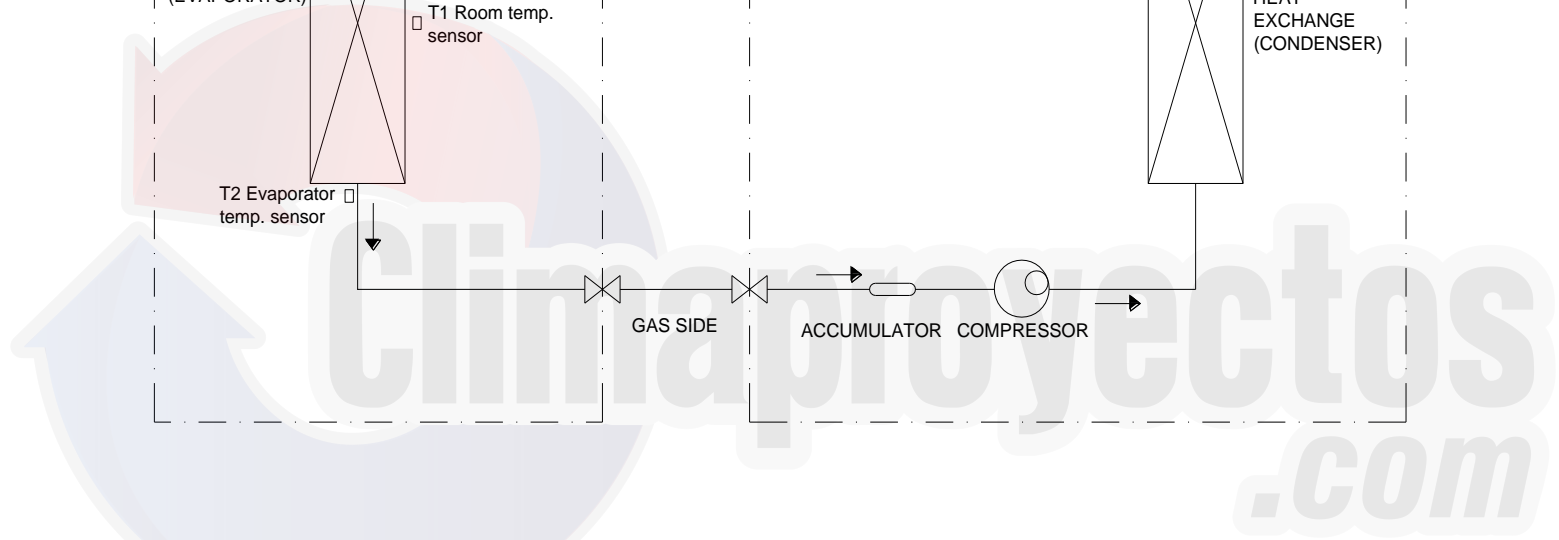
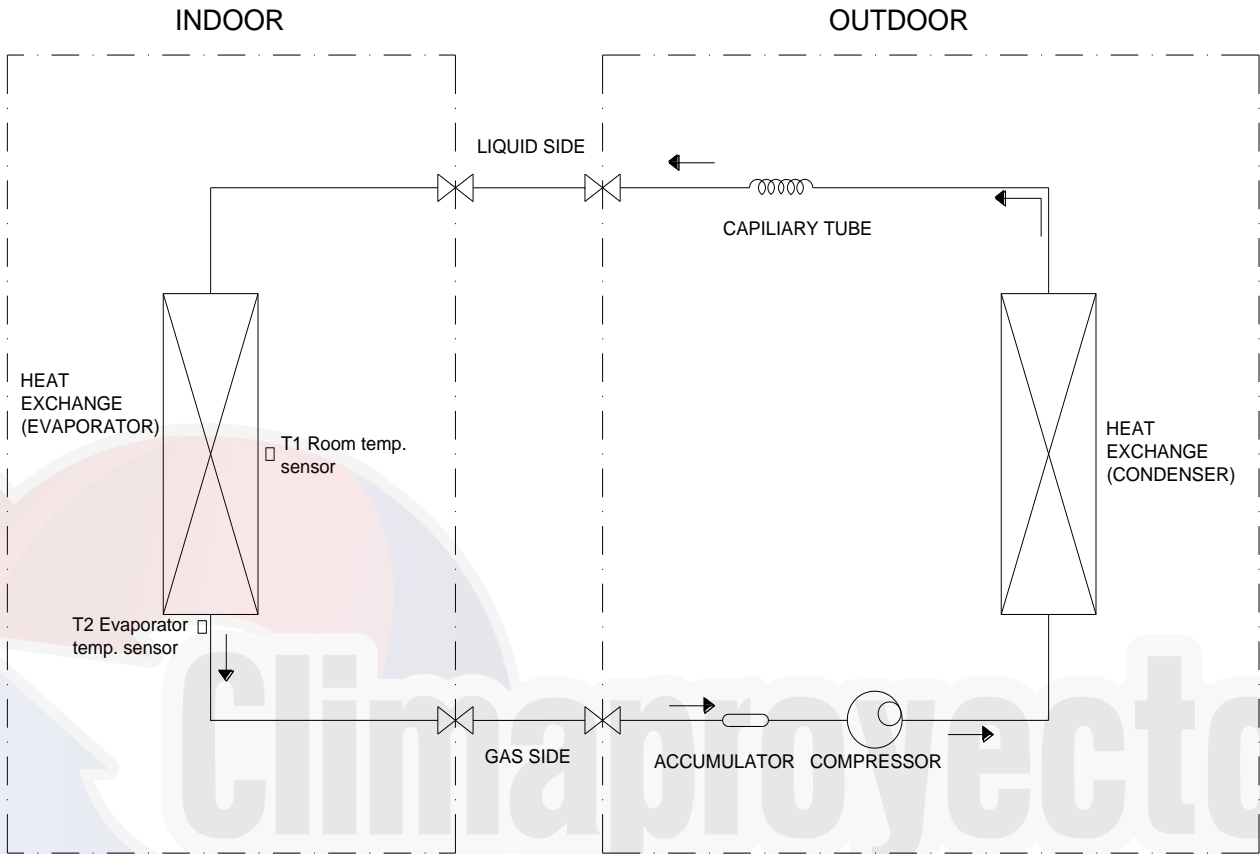

For heat pump models:

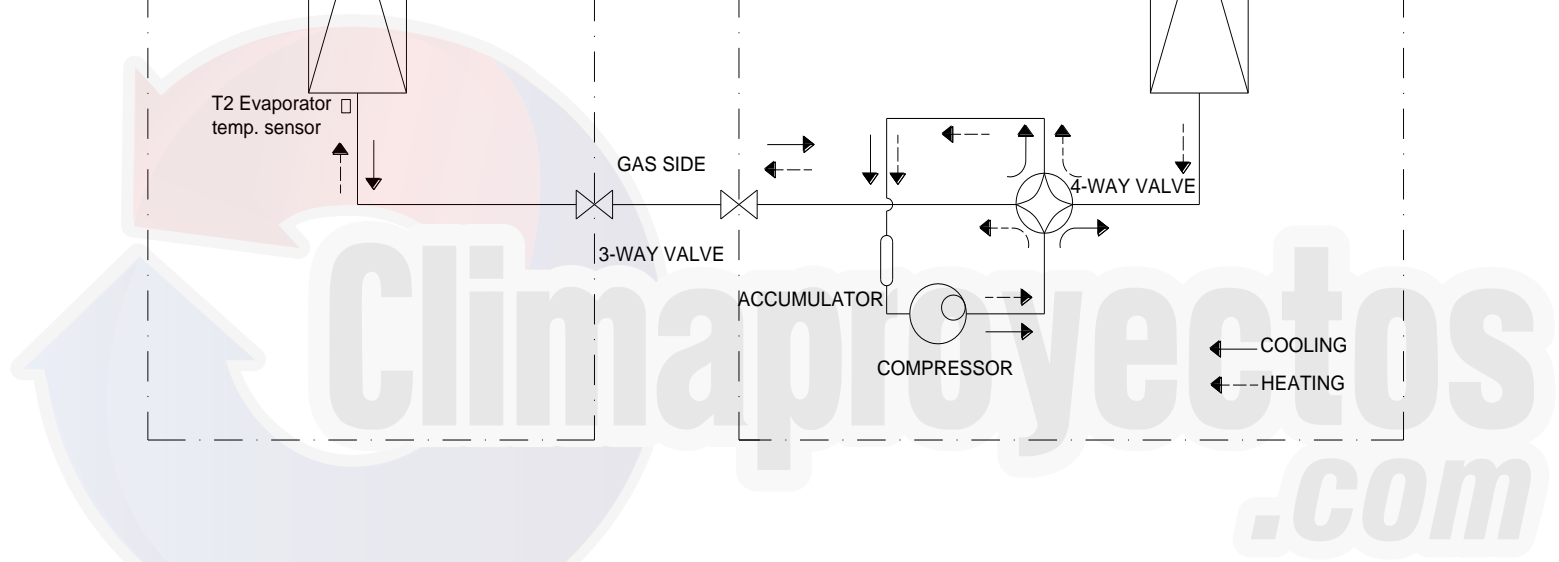
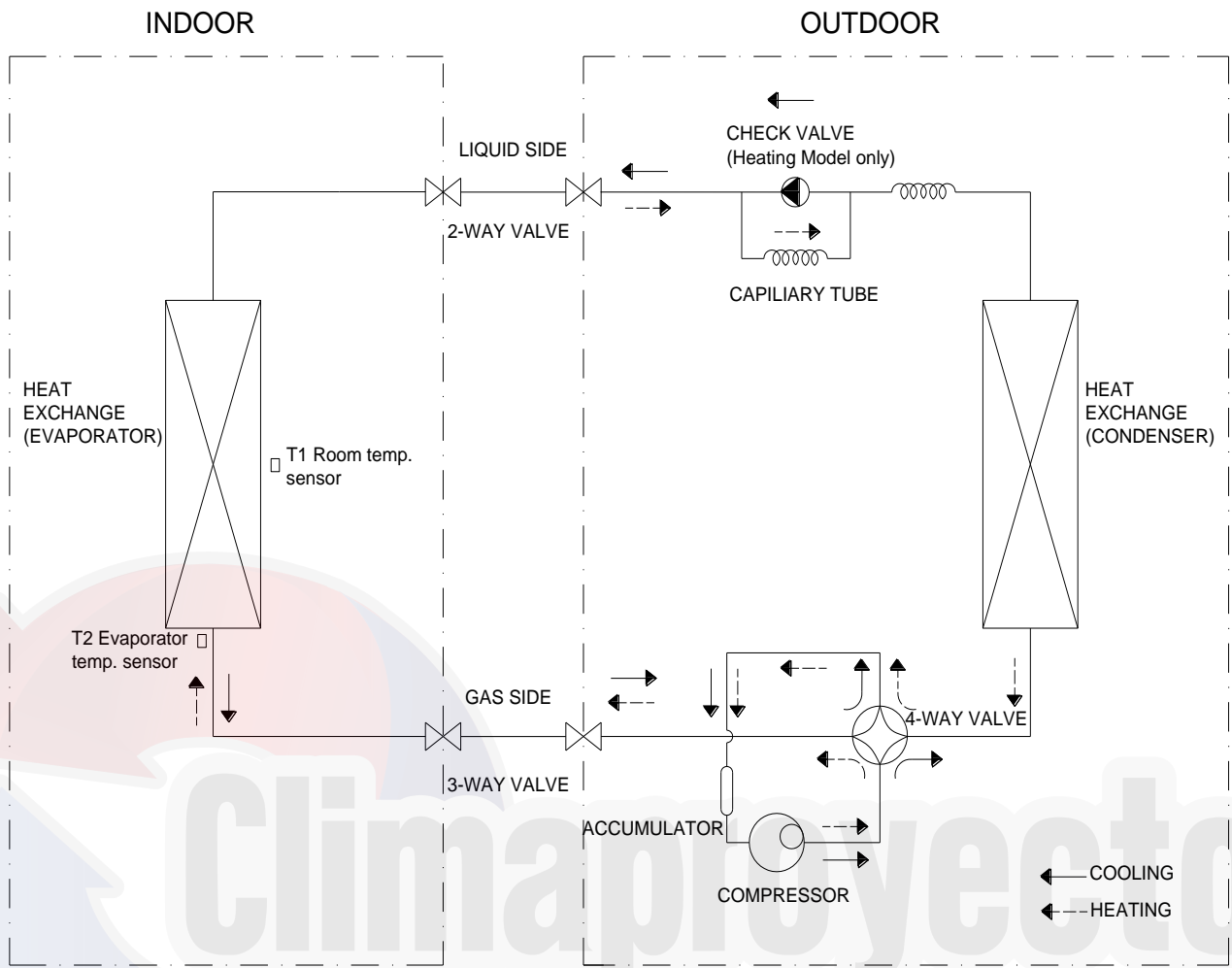

5 Installation Details

5.1 Wrench torque sheet for installation

| Outside diameter | | Torque | Additional tightening torque |
|------------------|------|-----------------|------------------------------|
| mm | inch | N.cm | N.cm |
| Φ6.35 | 1/4 | 1500(153kgf.cm) | 1600(163kgf.cm) |
| Φ9.52 | 3/8 | 2500(255kgf.cm) | 2600(265kgf.cm) |
| Φ12.7 | 1/2 | 3500(357kgf.cm) | 3600(367kgf.cm) |
| Φ15.9 | 5/8 | 4500(459kgf.cm) | 4700(479kgf.cm) |
| Φ19 | 3/4 | 6500(663kgf.cm) | 6700(683kgf.cm) |

5.2 Connecting the cables

The power cord of connect should be selected according to the following specifications sheet.

| Rated current of appliance | Nominal cross-sectional area (mm ²) |
|----------------------------|---|
| >3 and ≤6 | 0.75 |
| >6 and ≤10 | 1 |
| >10 and ≤16 | 1.5 |
| >16 and ≤25 | 2.5 |

The cable size and the current of the fuse or switch are determined by the maximum current indicated on the nameplate which located on the side panel of the unit. Please refer to the nameplate before selecting the cable, fuse and switch.

climaproyectos.com

5.3 Pipe length and the elevation

The pipe length and refrigerant amount:

| Model | Pipe size | | Standard length (m) | Max. Elevation B (m) | Max. Length A (m) | Additional refrigerant (g/m) |
|--------------------------------|-----------------|-----------------|---------------------|----------------------|-------------------|------------------------------|
| | Gas | Liquid | | | | |
| MSMBB-12CR-BB8+ MOA2-12C-BB8 | 1/2" (Φ12.7) | 1/4" (Φ6.35) | 5 | 5 | 10 | 15 |
| MSMBB-12HR-BB8+ MOA1-12H-BB8 | 1/2" (Φ12.7) | 1/4" (Φ6.35) | 5 | 5 | 10 | 15 |
| MSMBB-12CR-NB8+ MOB3-12C-NB8 | 1/2" (Φ12.7) | 1/4" (Φ6.35) | 5 | 5 | 10 | 15 |
| MSMBB-12HR-NB8+ MOB3-12H-NB8 | 1/2" (Φ12.7) | 1/4" (Φ6.35) | 5 | 5 | 10 | 15 |
| MSMBC-17CR-NB8+ MOB2-17C-NB8 | 1/2" (Φ12.7) | 1/4" (Φ6.35) | 5 | 5 | 10 | 15 |
| MSMBC-17HR-NB8+ MOB1-17H-NB8 | 1/2" (Φ12.7) | 1/4" (Φ6.35) | 5 | 5 | 10 | 15 |
| MSMBD-21CR-NB8W+ MOF3-21C-NB8W | 5/8" (Φ16.0) | 3/8" (Φ9.52) | 5 | 10 | 20 | 30 |
| MSMBD-21HR-NB8W+ MOF2-21H-NB8W | 5/8" (Φ16.0) | 3/8" (Φ9.52) | 5 | 10 | 20 | 30 |

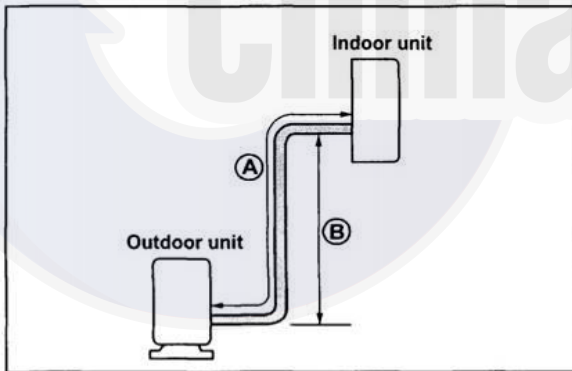

Caution:

The capacity test is based on the standard length and the maximum permissible length is based on the system reliability.

5.4 Installation for the first time

Air and moisture in the refrigerant system have undesirable effects as below:

- Pressure in the system rises.
- Operating current rises.
- Cooling or heating efficiency drops.
- Moisture in the refrigerant circuit may freeze and block capillary tubing.
- Water may lead to corrosion of parts in the refrigerant system.

Therefore, the indoor units and the pipes between indoor and outdoor units must be leak tested and evacuated to remove gas and moisture from the system.

Gas leak check (Soap water method):

Apply soap water or a liquid neutral detergent on the indoor unit connections or outdoor unit connections by a soft brush to check for leakage of the connecting points of the piping. If bubbles come out, the pipes have leakage.

1. Air purging with vacuum pump

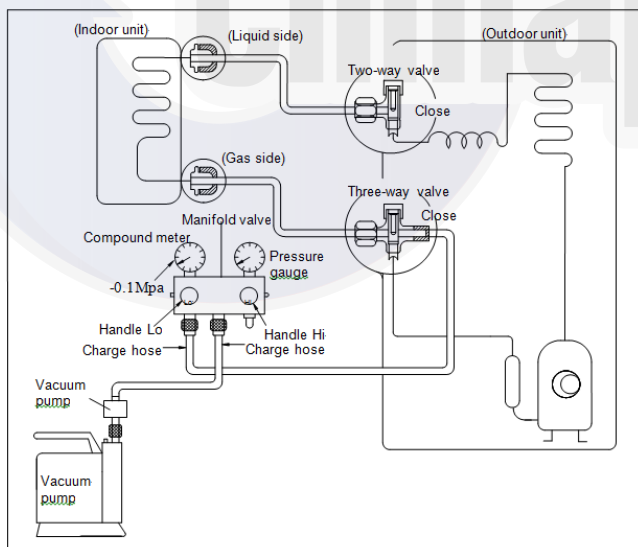

- 1) Completely tighten the flare nuts of the indoor and outdoor units, confirm that both the 2-way and 3-way valves are set to the closed position.
- 2) Connect the charge hose with the push pin of handle lo to the 3-way valves gas service port..
- 3) Connect the charge hose of handle hi connection to the vacuum pump.

- 4) Fully open the handle Lo of the manifold valve.
- 5) Operate the vacuum pump to evacuate.
- 6) Make evacuation for 30 minutes and check whether the compound meter indicates -0.1Mpa. If the meter does not indicate -0.1Mpa after pumping 30 minutes, it should be pumped 20 minutes more. If the pressure can't achieve -0.1Mpa after pumping 50 minutes, please check if there are some leakage points.

Fully close the handle Lo valve of the manifold valve and stop the operation of the vacuum pump. Confirm that the gauge needle does not move (approximately 5 minutes after turning off the vacuum pump).

- 7) Turn the flare nut of the 3-way valves about 45° counterclockwise for 6 or 7seconds after the gas

coming out, then tighten the flare nut again. Make sure the pressure display in the pressure indicator is a little higher than the atmosphere pressure. Then remove the charge hose from the 3 way valve.

- 8) Fully open the 2 way valve and 3 way valve and securely tighten the cap of the 3 way valve.

2. Air purging by refrigerant

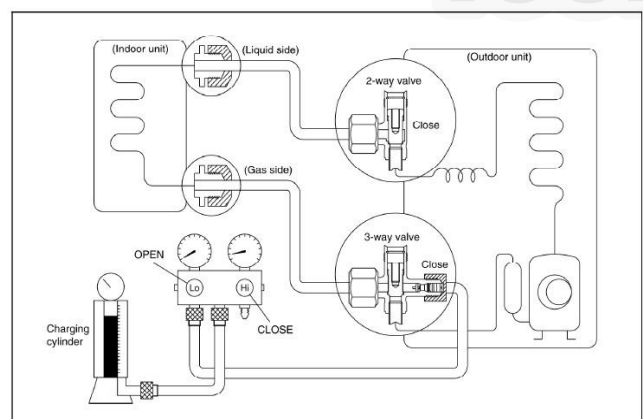

Procedure:

- 1). Confirm that both the 2-way and 3-way valves are set to the closed position.
- 2). Connect the charge set and a charging cylinder to the service port of the 3-way valve.
- 3). Air purging.
Open the valves on the charging cylinder and the

charge set. Purge the air by loosening the flare nut on the 2-way valve approximately 45' for 3 seconds then closing it for 1 minute; repeat 3 times.

After purging the air, use a torque wrench to tighten the flare nut on the 2-way valve.

4). Check the gas leakage.

Check the flare connections for gas leakage.

5). Discharge the refrigerant.

Close the valve on the charging cylinder and discharge the refrigerant by loosening the flare nut on the 2-way valve approximately 45' until the gauge indicates 0.3 to 0.5 Mpa.

6). Disconnect the charge set and the charging cylinder, and set the 2-way and 3-way valves to the open position.

Be sure to use a hexagonal wrench to operate the valve stems.

7). Mount the valve stems nuts and the service port cap.

Be sure to use a torque wrench to tighten the service port cap to a torque 18N·m.

Be sure to check the gas leakage.

3. Adding the refrigerant if the pipe length >5m

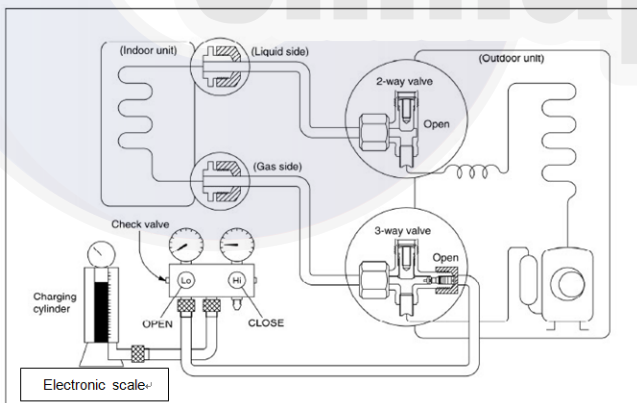

Procedure:

1). Connect the charge hose to the charging cylinder, open the 2-way valve and the 3-way valve.

Connect the charge hose which you disconnected from the vacuum pump to the valve at the bottom of the cylinder. If the refrigerant is R410A, make the cylinder bottom up to ensure the liquid charge.

2). Purge the air from the charge hose.

Open the valve at the bottom of the cylinder

and press the check valve on the charge set to purge the air (be careful of the liquid refrigerant).

3) Put the charging cylinder onto the electronic scale and record the weight.

4) Operate the air conditioner at the cooling mode.

5) Open the valves (Low side) on the charge set and charge the system with liquid refrigerant.

6).When the electronic scale displays the proper weight (refer to the table), disconnect the charge hose from the 3-way valve's service port immediately and turn off the air conditioner before disconnecting the hose.

7). Mount the valve stem caps and the service port

Use torque wrench to tighten the service port cap to a torque of 18N.m.

Be sure to check for gas leakage.

5.5 Adding the refrigerant after running the system for many years

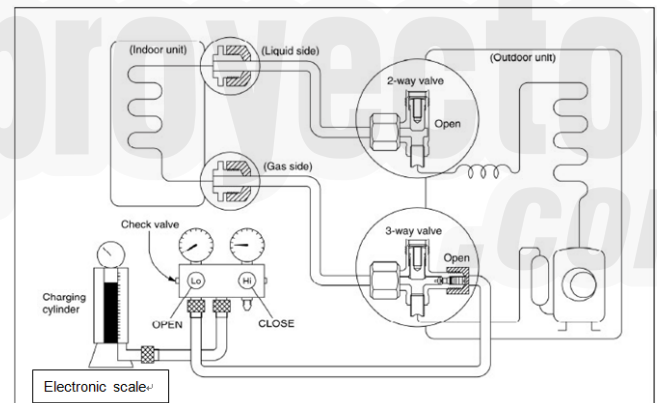

Procedure:

1). Connect the charge hose to the 3-way service port, open the 2-way valve and the 3-way valve.

Connect the charge hose to the valve at the bottom of the cylinder. If the refrigerant is R410A, make the cylinder bottom up to ensure liquid charge.

2). Purge the air from the charge hose.

Open the valve at the bottom of the cylinder and press the check valve on the charge set to purge the air (be careful of the liquid refrigerant).

3) Put the charging cylinder onto the electronic scale and record the weight.

4) Operate the air conditioner at the cooling

mode.

5) Open the valves (Low side) on the charge set and charge the system with liquid refrigerant.

6).When the electronic scale displays the proper weight (refer to the gauge and the pressure of the low side), disconnect the charge hose from the 3-way valve's service port immediately and turn off the air conditioner before disconnecting the hose.

7). Mount the valve stem caps and the service port

Use torque wrench to tighten the service port cap to a torque of 18N.m.

Be sure to check for gas leakage.

5.6 Re-installation while the indoor unit need to be repaired

1. Collecting the refrigerant into the outdoor unit

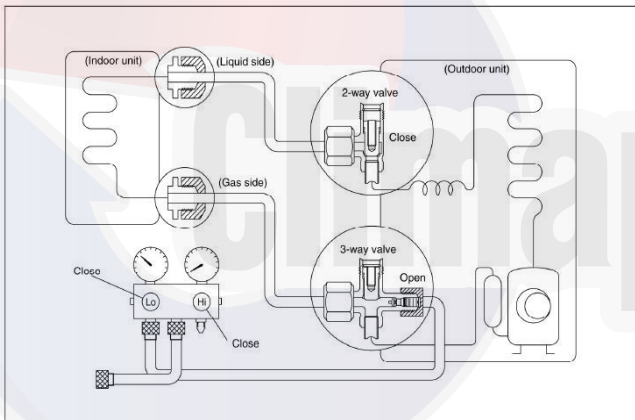

Procedure

1). Confirm that both the 2-way and 3-way valves are set to the opened position

Remove the valve stem caps and confirm that the valve stems are in the opened position.

Be sure to use a hexagonal wrench to operate the valve stems.

2). Connect the charge hose with the push pin of handle lo to the 3-way valves gas service port.

3). Air purging of the charge hose.

Open the handle Lo valve of the manifold valve slightly to purge air from the charge hose for 5 seconds and then close it quickly.

4). Set the 2-way valve to the close position.

5). Operate the air conditioner at the cooling cycle and stop it when the gauge indicates 0.1MPa.

6). Set the 3-way valve to the closed position

immediately

Do this quickly so that the gauge ends up indicating 0.3 to 0.5Mpa.

Disconnect the charge set, and tighten the 2-way and 3-way valve's stem nuts.

Use a torque wrench to tighten the 3-way valves service port cap to a torque of 18N.m.

Be sure to check for gas leakage.

2. Air purging by the refrigerant

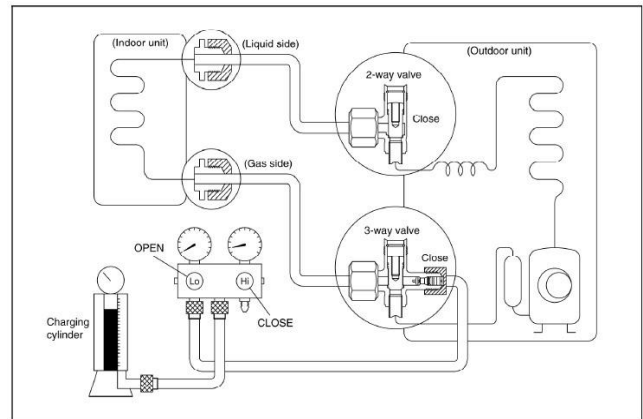

Procedure:

1). Confirm that both the 2-way and 3-way valves are set to the closed position.

2). Connect the charge set and a charging cylinder to the service port of the 3-way valve Leave the valve on the charging cylinder closed.

3). Air purging.

Open the valves on the charging cylinder and the charge set. Purge the air by loosening the flare nut on the 2-way valve approximately 45° for 3 seconds then closing it for 1 minute; repeat 3 times.

After purging the air, use a torque wrench to tighten the flare nut on the 2-way valve.

4). Check the gas leakage

Check the flare connections for gas leakage.

5). Discharge the refrigerant.

Close the valve on the charging cylinder and discharge the refrigerant by loosening the flare nut on the 2-way valve approximately 45° until the gauge indicates 0.3 to 0.5 Mpa.

6). Disconnect the charge set and the charging cylinder, and set the 2-way and 3-way valves to the open position

Be sure to use a hexagonal wrench to operate the valve stems.

7). Mount the valve stems nuts and the service port cap

Be sure to use a torque wrench to tighten the service port cap to a torque 18N.m.

Be sure to check the gas leakage.

5.7 Re-installation while the outdoor unit need to be repaired

1. Evacuation for the whole system

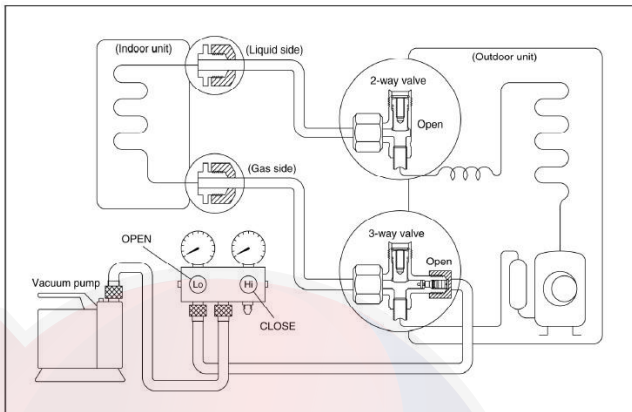

Procedure:

- 1). Confirm that both the 2-way and 3-way valves are set to the opened position.
- 2). Connect the vacuum pump to 3-way valve's service port.
- 3). Evacuation for approximately one hour. Confirm that the compound meter indicates -0.1Mpa.
- 4). Close the valve (Low side) on the charge set, turn off the vacuum pump, and confirm that the gauge needle does not move (approximately 5 minutes after turning off the vacuum pump).
- 5). Disconnect the charge hose from the vacuum pump.

2. Refrigerant charging

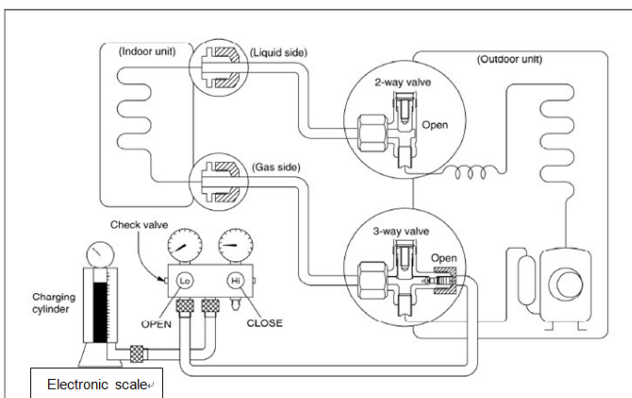

Procedure:

- 1). Connect the charge hose to the charging cylinder, open the 2-way valve and the 3-way valve

Connect the charge hose which you disconnected from the vacuum pump to the valve at the bottom of the cylinder. If the refrigerant is R410A, make the cylinder bottom up to ensure liquid charge.

- 2). Purge the air from the charge hose

Open the valve at the bottom of the cylinder and press the check valve on the charge set to purge the air (be careful of the liquid refrigerant).

- 3) Put the charging cylinder onto the electronic scale and record the weight.

- 4). Open the valves (Low side) on the charge set and charge the system with liquid refrigerant

If the system cannot be charge with the specified amount of refrigerant, or can be charged with a little at a time (approximately 150g each time) , operating the air conditioner in the cooling cycle; however, one time is not sufficient, wait approximately 1 minute and then repeat the procedure.

- 5).When the electronic scale displays the proper weight, disconnect the charge hose from the 3-way valve's service port immediately

If the system has been charged with liquid refrigerant while operating the air conditioner, turn off the air conditioner before disconnecting the hose.

- 6). Mounted the valve stem caps and the service port

Use torque wrench to tighten the service port cap to a torque of 18N.m.

Be sure to check for gas leakage

6. Operation Characteristics

| Mode | Cooling operation | Heating operation | Drying operation |
|----------------------------|--|--------------------------|--|
| Temperature | | | |
| Room temperature | 17°C~32°C (62°F~90°F) | 0°C~30°C (32°F~86°F) | 10°C~32°C (50°F~90°F) |
| Outdoor temperature | 18°C~43°C (64°F~109°F) | -7°C~24°C (20°F~78°F) | 11°C~43°C (52°F~109°F) |
| | -7°C~43°C (20°F~109°F) (For the models with low temperature cooling system) | | 18°C~52°C (64°F~126°F) (For special tropical models) |
| | 18°C~52°C (64°F~126°F) (For special tropical models) | | |

CAUTION:

1. If the air conditioner is used beyond the above conditions, certain safety protection features may come into operation and cause the unit to operate abnormally.
2. The room relative humidity should be less than 80%. If the air conditioner operates beyond this figure, the surface of the air conditioner may attract condensation. Please set the vertical air flow louver to its maximum angle (vertically to the floor), and set HIGH fan mode.
3. The optimum performance will be achieved during this operating temperature zone.

7. Electronic function

7.1 Abbreviation

- T1: Indoor room temperature
- T2: Coil temperature of evaporator
- T3: Coil temperature of condenser
- T4: Outdoor ambient temperature
- T5: Compressor discharge temperature

7.2 Display function

7.2.1 Icon explanation on indoor display board.



Digital display:

Displays the temperature settings when the air conditioner is operational.

Displays the room temperature in FAN mode.

Displays the self-diagnostic codes.

Displays '00' for three seconds when Timer ON, Fresh, Swing, Turbo or Silence feature is activated.

Displays 'DF' for three seconds when Timer OFF is set.

Displays 'DF' for three seconds when Fresh,

Swing, Turbo or Silence feature is cancelled.

Displays 'DF' under defrosting operation.

Displays 'CF' when anti-cold air feature is activated under heating mode.

Displays 'SC' during self clean operation (if applicable).

Displays 'FP' under 8°C heating operation (if applicable).

When ECO function(optional) is activated, the

"00" illuminates gradually one by one as E → C → 0 → set temperature → E

In one second interval.



WiFi control display(optional)

Displays when the WiFi control feature is activated.(Not available when the unit does not have this function)

NOTE:

A guide on using the infrared remote is included in this literature package..

7.3 Main Protection

7.3.1 Time Delay at restart for compressor.

7.3.2 Sensor protection at open circuit and breaking disconnection.

7.3.3 Zero crossing detection error protection

If AC can not detect zero crossing signal for 4 minutes or the zero crossing signal time interval is not correct, the unit will stop and the LED will display the failure. The correct zero crossing signal time interval should be between 6-13ms.

7.3.4 Fan Speed is out of control

When Indoor Fan Speed is too low(lower than 300RPM) lasting 2 minutes, the unit stops and LED displays failure information and can't returns to normal operation automatically.

7.3.5 Current protection

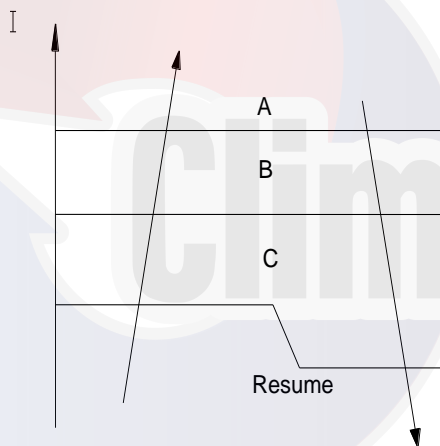

The current exceeds setting value for certain time, the compressor and outdoor fan will shut off.

7.4 Operation Modes and Functions

8.4.1 Fan mode

- (1) Outdoor fan and compressor stop.
- (2) Temperature setting function is disabled, and no setting temperature is displayed.
- (3) Indoor fan can be set to high/med/low/auto.
- (4) The louver operates the same as in cooling mode.
- (5) Auto fan:

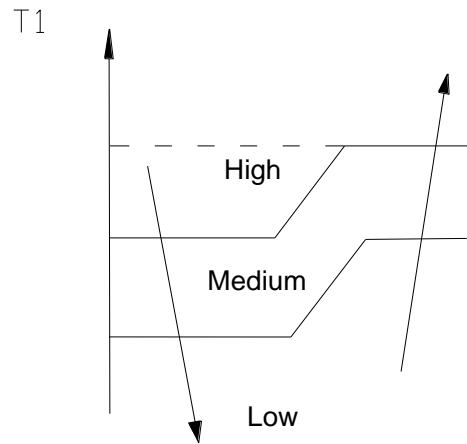

7.4.2 Cooling Mode

7.4.2.1 Compressor running rules

When indoor room temp.T1 is lower than setting value, the compressor and outdoor fan will shut off.

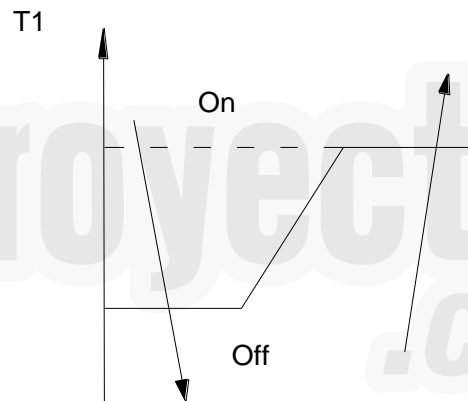

7.4.2.2 Outdoor fan running rules

The On-off outdoor units have single fan speed. The outdoor fan will run following the compressor except when AC is in evaporator high temp. protection in heating mode ,condenser high temp. protection in cooling mode, defrosting mode and the current protection.

7.4.2.3 Indoor fan running rules

In cooling mode, indoor fan runs all the time and the speed can be selected as high, medium, low and auto.

The auto fan:

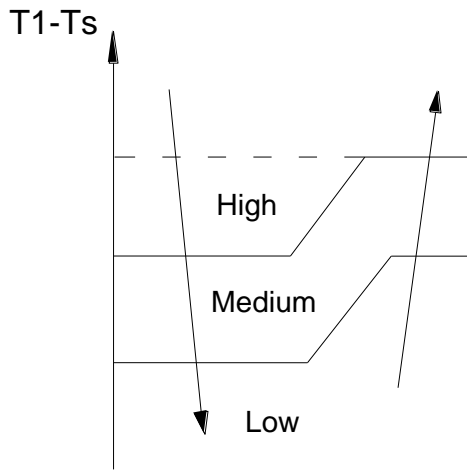

setting value, the compressor will stop. During the protection, the outdoor fan keeps working.

7.4.3 Heating Mode(only for heat pump models)

7.4.3.1 Compressor running rules:

When indoor room temp.T1 is higher than setting value the compressor and outdoor fan will shut off.

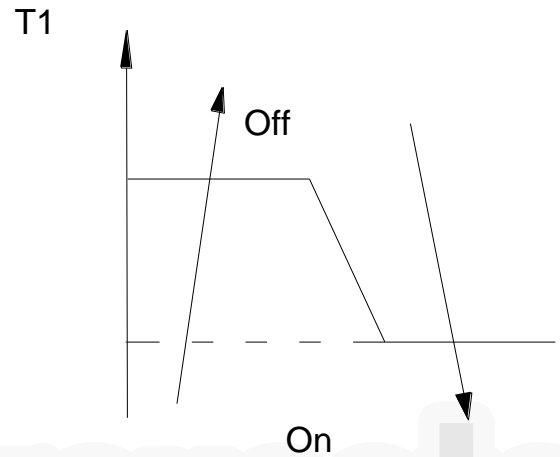

7.4.2.4 Low evaporator coil temperature T2 protection

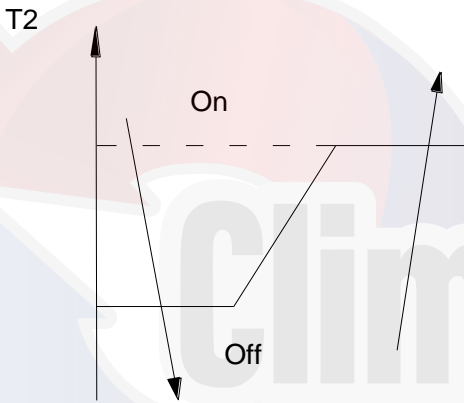

When the evaporator coil temp.T2 keeps lower than setting value, the compressor and outdoor fan will shut off.

7.4.3.2 Outdoor fan running rules:

The outdoor units have single fan speed. The outdoor fan will run following the compressor except when AC is in evaporator high temp. protection in heating mode , condenser high temp. protection in cooling mode ,defrosting mode and the current protection.

7.4.2.5 High condenser temperature T3 protection (only for MSMBD-21HR-NB8W)

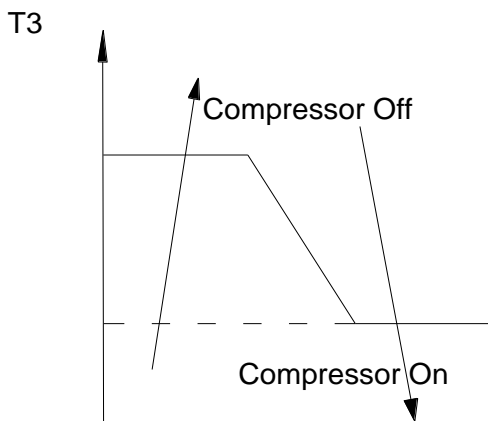

7.4.3.3 Indoor fan running rules:

When the compressor is on, the indoor fan can be set to high/med/low/auto. And the anti-cold wind function has the priority.

Auto fan action:

When high condenser temp. T3 is more than

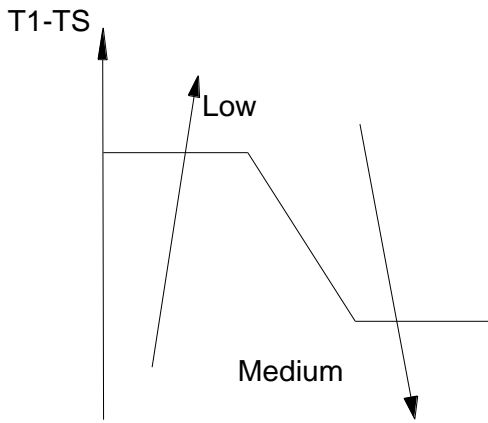

The indoor fan speed will adjust according to the value of T1-Ts.

7.4.3.4 Defrosting mode:

For **MSMBB-12HR-BB8, MSMBB-12HR-NB8, MSMBC-17HR-NB8,**

AC will enter the defrosting mode according to the value of temp difference between T2 and T1, and also the compressor running time.

During the defrosting mode, the compressor keep running, indoor and outdoor motor will stop, defrost lamp of the indoor unit will be lighted

“**DF**.” Will be displayed.

For **MSMBD-21HR-NB8W,**

AC will enter the defrosting mode according to the value of temp. of T3 and the value range of temp. change of T3 and also the compressor running time.

During the defrosting mode, the compressor keep running, indoor and outdoor motor will stop, defrost lamp of the indoor unit will be lighted

“**DF**.” Will be displayed.

7.4.3.5 High evaporator coil temp.T2 protection:

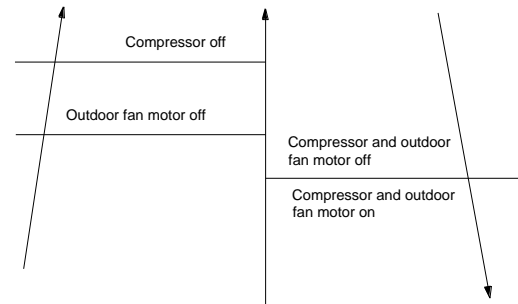

7.4.4 Auto-mode

This mode can be chosen with remote controller.

In auto mode, the machine will choose operation mode according to ΔT ($\Delta T = T1 - Ts$).

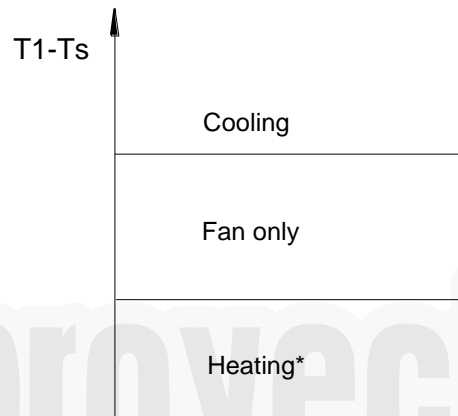

Heating*: For cooling only models, they will run at fan speed

AC will run in auto mode in the below cases:

- (1) Pressing the forced auto button.
- (2) If AC is off, it will run in auto mode when the timer on function is active.
- (3) After setting the mode, AC will run in auto mode if the compressor keeps not running for certain time.

7.4.5 Drying mode

8.4.5.1 The compressor is cycled running with 10 minutes on and then 5 minutes off. The indoor fan will keep running at low speed.

8.4.5.2 In drying mode, if room temperature is lower than 10°C, the compressor will stop and not resume until room temperature exceeds 13°C.

8.4.5.3 The evaporator anti-freezing protection is the same as that in cooling mode.

7.4.6 Forced operation function

Forced cooling mode:

The compressor and outdoor fan keep running and the indoor fan runs at low speed. After running for 30 minutes, AC will turn to auto mode with 24°C setting temperature.

Forced auto mode:

The action of forced auto mode is the same as normal auto mode with 24°C setting temperature.

When AC receives signals, such as switch on, switch off, timer on, timer off, mode setting, fan speed setting, sleeping mode setting, follow me setting, it will quit the forced operation.

7.4.9 Auto-Restart function

The indoor unit is equipped with auto-restart function, which is carried out through an auto-restart module. In case of a sudden power failure, the module memorizes the setting conditions before the power failure. The unit will resume the previous operation setting (not including swing function) automatically after 3 minutes when power returns.

If the memorization condition is forced cooling mode, the unit will run in cooling mode for 30 minutes and turn to auto mode as 24°C setting temp.

If AC is off before power off and AC is required to start up now, the compressor will have 1 minute delay when power on. Other conditions, the compressor will have 3 minutes delay when restarts.

7.4.10 Refrigerant Leakage Detection

With this new technology, the display area will show "EC" when the outdoor unit detects refrigerant leakage.

When compressor is active, the value of the Coil temperature of evaporator T2 has no change or very little change.

7.4.12 8°C Heating(optional)

When the compressor is running, the indoor fan motor will run without anti-cold air function.

When the compressor is off, the indoor fan

motor is off .

proyectos.com

8. Troubleshooting

8.1 Indoor Unit Error Display

| Operation lamp | Timer lamp | Display | LED STATUS |
|----------------|------------|---------|--|
| ☆ 1 time | X | E1 | EEPROM parameter error |
| ☆ 2 times | X | E2 | Zero-crossing signal detection error |
| ☆ 3 times | X | E3 | Indoor fan speed has been out of control |
| ☆ 5 times | X | E5 | Indoor room temperature sensor T1 open circuit or short circuit |
| ☆ 6 times | X | E6 | Evaporator coil temperature sensor T2 open circuit or short circuit |
| ☆ 7 times | X | E7 | Condenser coil temperature sensor T3 or T4 open circuit or short circuit(only for MSMBD-21HR-NB8W) |
| ☆ 2 times | O | EC | Refrigerant Leakage Detection |
| ☆ 9 times | X | E9 | Indoor / outdoor units communication error(only for MSMBD-21CR-NB8W, MSMBD-21HR-NB8W) |

O (light)

X (off)

☆ (flash)

Climaproyectos
.com

8.2 Diagnosis and Solution

8.2.1 EEPROM parameter error diagnosis and solution

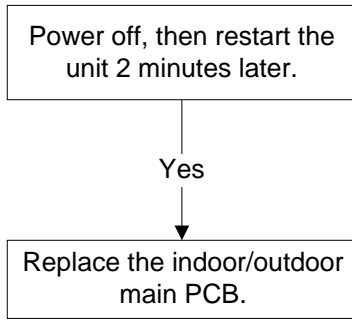

EEPROM: a read-only memory whose contents can be erased and reprogrammed using a pulsed voltage.



8.2.2 Zero crossing detection error diagnosis and solution

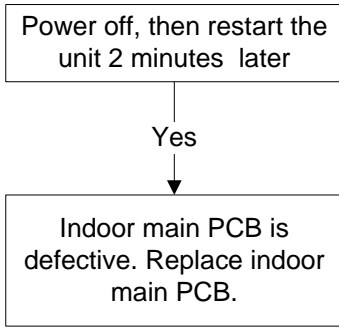

8.2.3 Indoor fan speed has been out of control diagnosis and solution

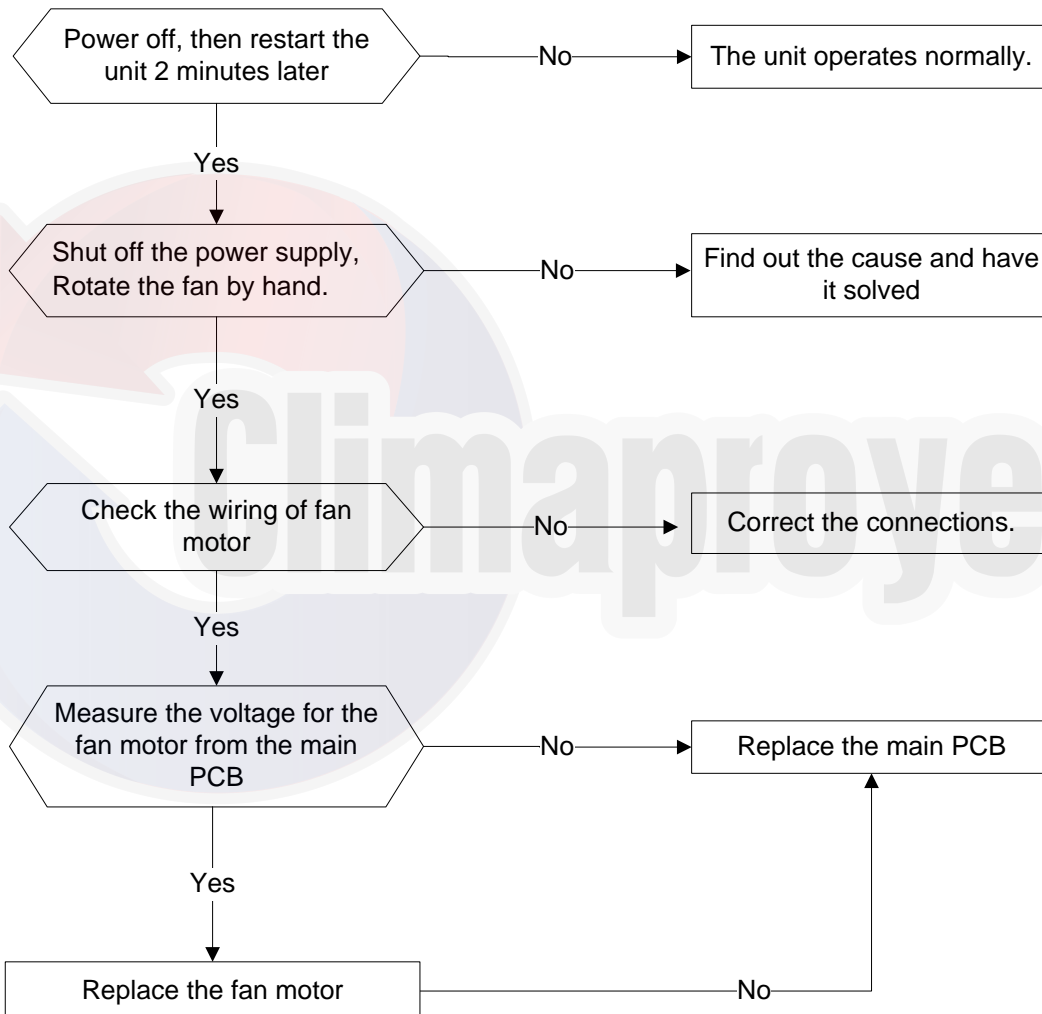

Index 1:

1: Indoor AC Fan Motor

Measure the resistance value of each winding by using the tester.

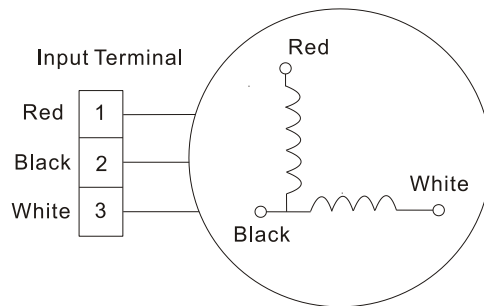

For the resistance value of the motor, please contact the technical engineer.

Index2:

1: Indoor AC Fan Motor

Power on and set the unit running in fan mode at high fan speed. After running for 15 seconds, measure the voltage of pin1 and pin2. If the value of the voltage is less than 100V(208~240V power supply) or 50V(115V power supply), the PCB must have problems and need to be replaced.

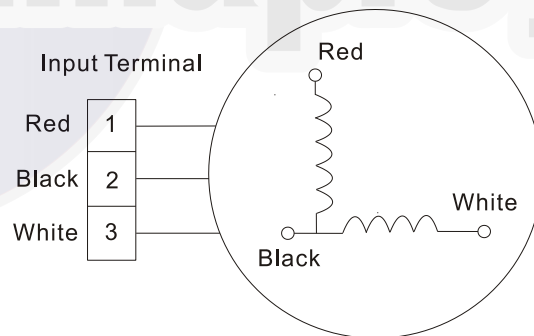

8.2.4 Open circuit or short circuit of temperature sensors diagnosis and solution

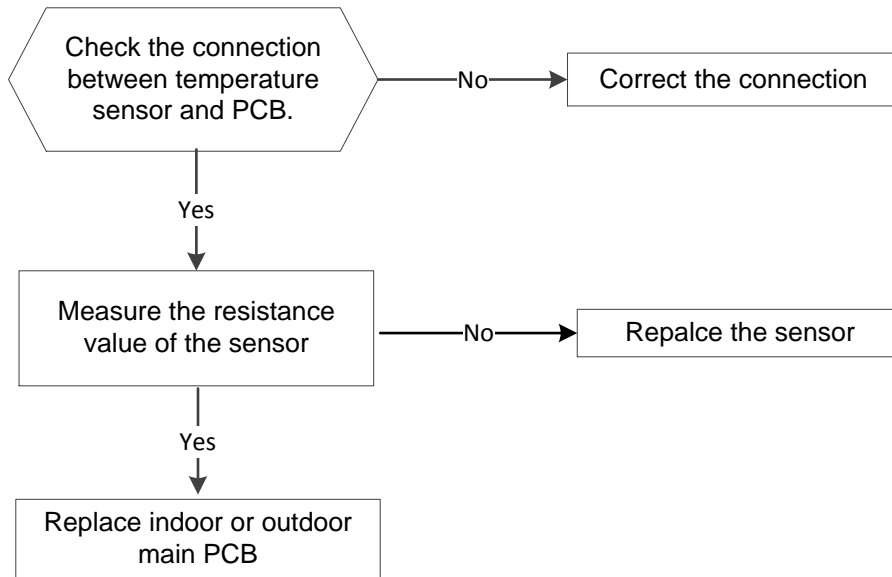

8.2.5 Refrigerant Leakage Detection diagnosis and solution

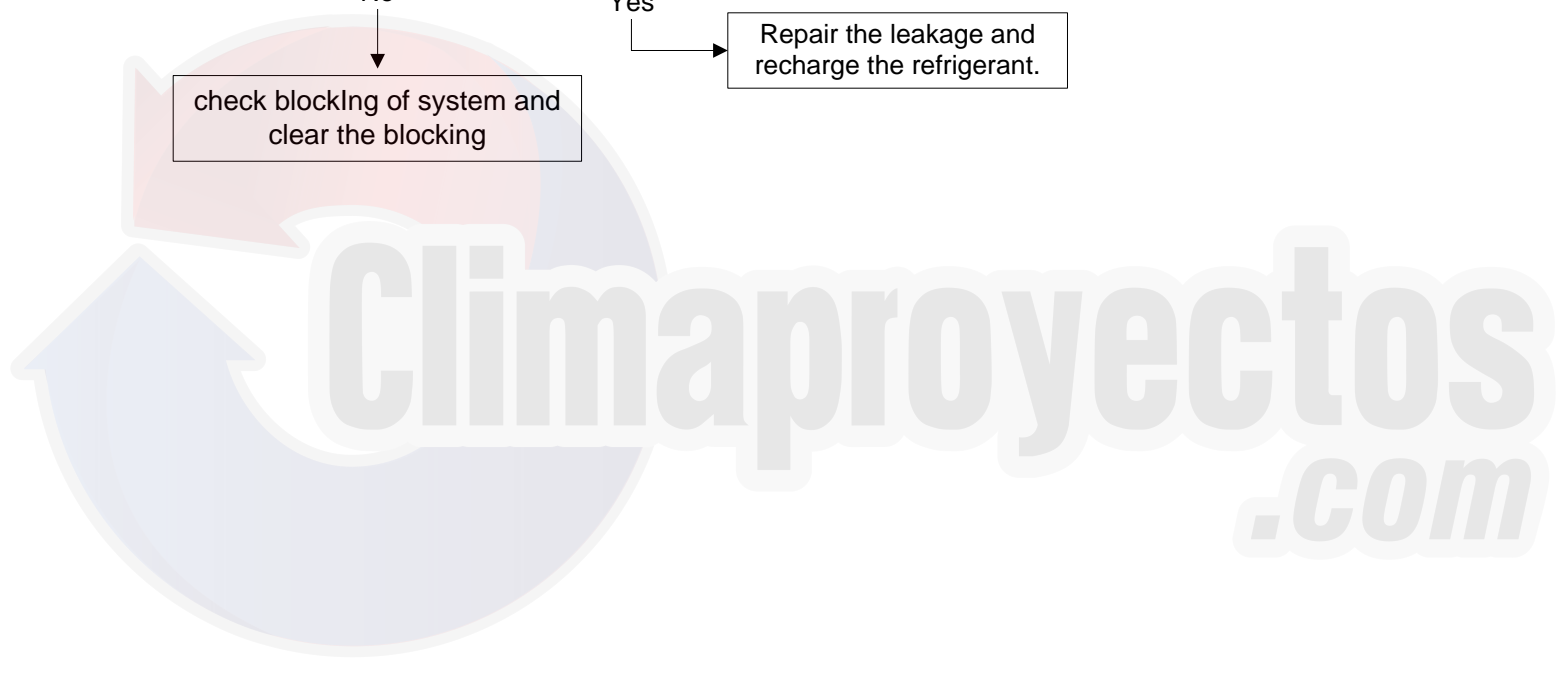
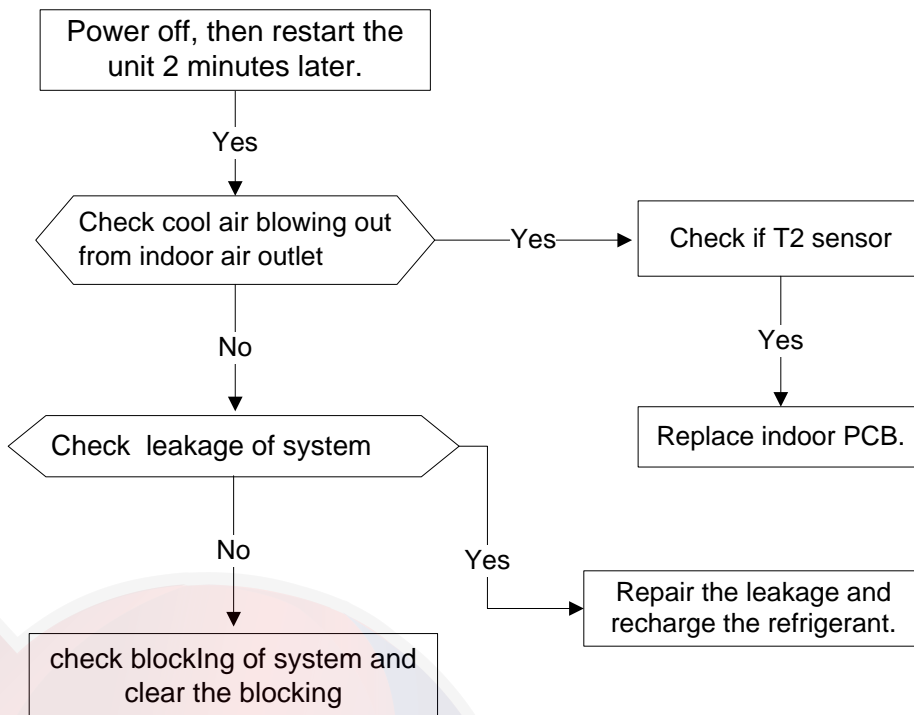

8.2.6 Indoor / outdoor units communication error diagnosis and solution

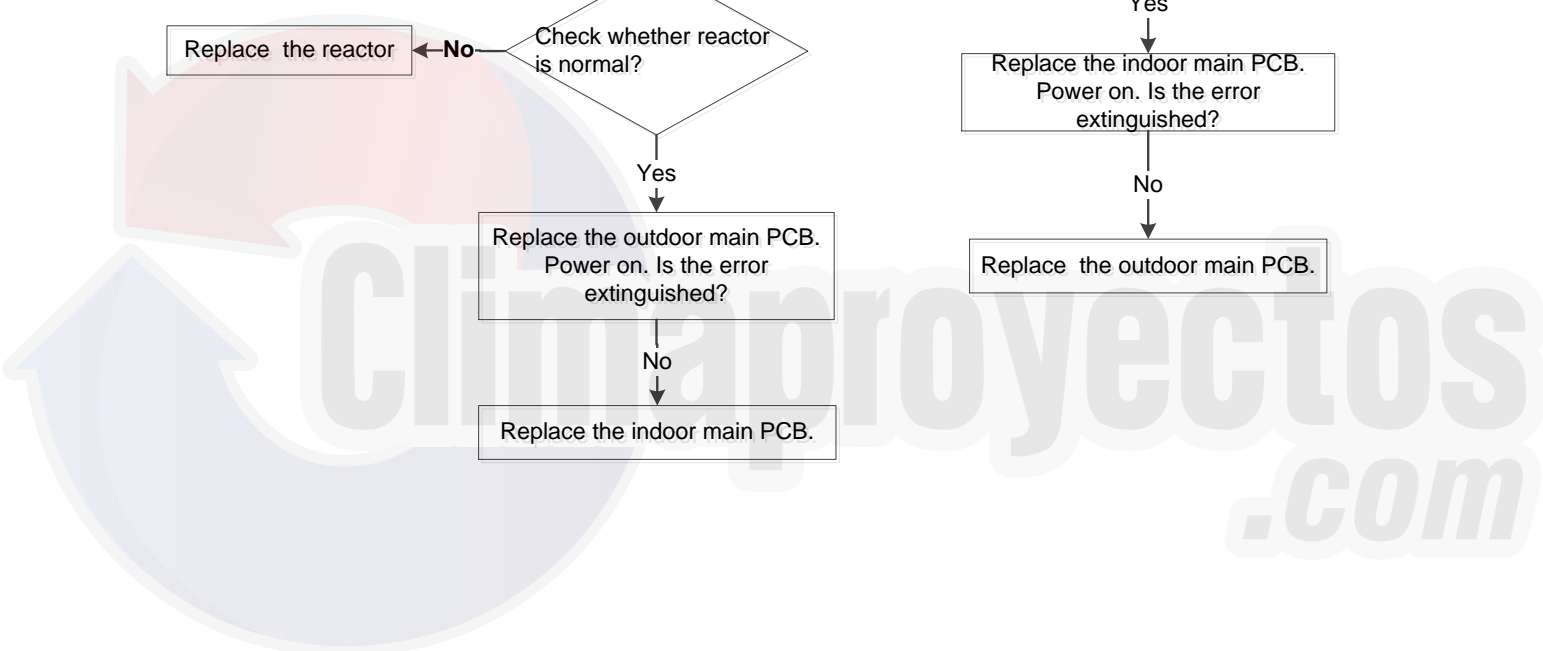
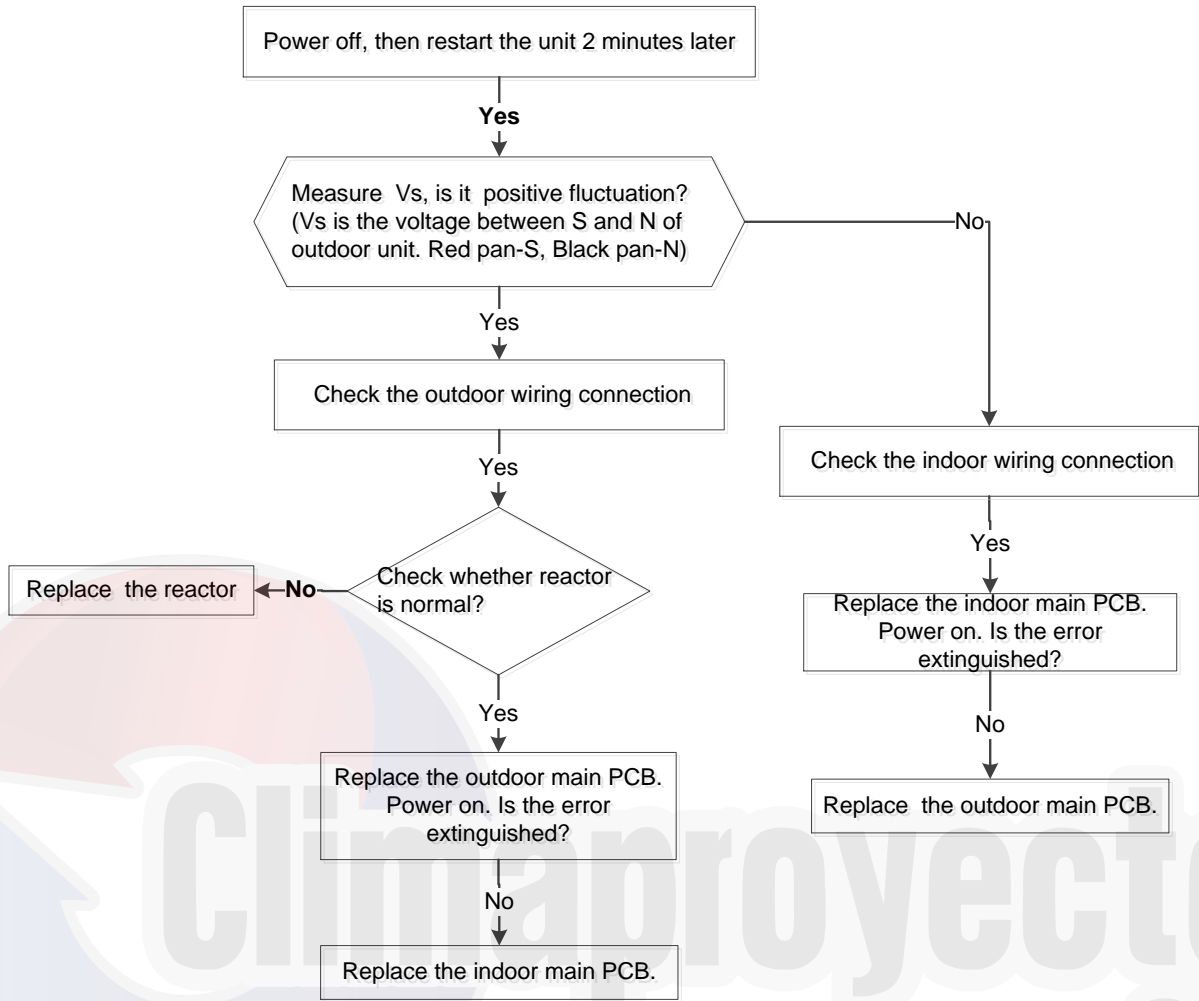

Main parts check

1. Temperature sensor checking

Disconnect the temperature sensor from PCB, measure the resistance value with a tester.

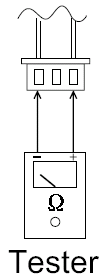

Temperature Sensors.

- Room temp.(T1) sensor,
 - Indoor coil temp.(T2) sensor,
 - Outdoor coil temp.(T3) sensor,
 - Outdoor ambient temp.(T4) sensor,
 - Compressor discharge temp.(T5) sensor.
- Measure the resistance value of each winding by using the multi-meter.

Table1:Some frequently-used R-T data for T1,T2,T3 and T4 sensor:

| | | | | | | | | | |
|-----------------------|------|------|------|------|----|----|-----|-----|-----|
| Temperature (°C) | 5 | 10 | 15 | 20 | 25 | 30 | 40 | 50 | 60 |
| Resistance Value (KΩ) | 26.9 | 20.7 | 16.1 | 12.6 | 10 | 8 | 5.2 | 3.5 | 2.4 |

Table2:Some frequently-used R-T data for T5 sensor:

| | | | | | | | | | |
|-----------------------|-------|----|------|------|------|-----|-----|----|-----|
| Temperature (°C) | 5 | 15 | 25 | 35 | 60 | 70 | 80 | 90 | 100 |
| Resistance Value (KΩ) | 141.6 | 88 | 56.1 | 36.6 | 13.8 | 9.7 | 6.9 | 5 | 3.7 |

Resistance value (KΩ)

