

# Service Manual

## TABLE OF CONTENTS

	PAGE
SAFETY CONSIDERATIONS .....	1
INTRODUCTION .....	1
MODEL / SERIAL NUMBER NOMENCLATURE .....	2
STANDARD FEATURES AND ACCESSORIES .....	3
SPECIFICATIONS (HEAT PUMP ONLY UNITS) MAQ .....	4
DIMENSIONS - INDOOR .....	5
DIMENSIONS - OUTDOOR .....	6
CLEARANCES - INDOOR .....	9
CLEARANCES - OUTDOOR .....	9
WIRING .....	10
CONNECTION DIAGRAMS .....	11
WIRING DIAGRAMS .....	12
FAN AND MOTOR SPECIFICATIONS .....	17
SOUND DATA SPECIFICATION .....	17
REFRIGERATION CYCLE DIAGRAM .....	21
REFRIGERANT LINES .....	21
SYSTEM EVACUATION AND CHARGING .....	22
CONTROL SYSTEM .....	24
SEQUENCE OF OPERATION .....	25
MODES OF OPERATION .....	25
TROUBLESHOOTING .....	29
APPENDIX .....	61

## SAFETY CONSIDERATIONS

Installing, starting up, and servicing air-conditioning equipment can be hazardous due to system pressures, electrical components, and equipment location (roofs, elevated structures, etc.).

Only trained, qualified installers and service mechanics should install, start-up, and service this equipment.

Untrained personnel can perform basic maintenance functions such as cleaning coils. All other operations should be performed by trained service personnel.

When working on the equipment, observe precautions in the literature and on tags, stickers, and labels attached to the equipment.

Follow all safety codes. Wear safety glasses and work gloves. Keep quenching cloth and fire extinguisher nearby when brazing. Use care in handling, rigging, and setting bulky equipment.

Read this manual thoroughly and follow all warnings or cautions included in literature and attached to the unit. Consult local building codes and National Electrical Code (NEC) for special requirements.

Recognize safety information. This is the safety-alert symbol . When you see this symbol on the unit and in instructions or manuals, be alert to the potential for personal injury. Understand these signal words: DANGER, WARNING, and CAUTION.

These words are used with the safety-alert symbol. DANGER identifies the most serious hazards which **will** result in severe personal injury or death. WARNING signifies hazards which **could** result in personal injury or death. CAUTION is used to identify unsafe practices which **may** result in minor personal injury or product and property damage. NOTE is used to highlight suggestions which **will** result in enhanced installation, reliability, or operation.



## WARNING

**ELECTRICAL SHOCK HAZARD**

Failure to follow this warning could result in personal injury or death.

Before installing, modifying, or servicing system, main electrical disconnect switch must be in the OFF position. There may be more than 1 disconnect switch. Lock out and tag switch with a suitable warning label.



## WARNING



**EXPLOSION HAZARD**

Failure to follow this warning could result in death, serious personal injury, and/or property damage.

Never use air or gases containing oxygen for leak testing or operating refrigerant compressors. Pressurized mixtures of air or gases containing oxygen can lead to an explosion.



## CAUTION

**EQUIPMENT DAMAGE HAZARD**

Failure to follow this caution may result in equipment damage or improper operation.

Do not bury more than 36 in. (914 mm) of refrigerant pipe in the ground. If any section of pipe is buried, there must be a 6 in. (152 mm) vertical rise to the valve connections on the outdoor units. If more than the recommended length is buried, refrigerant may migrate to the cooler buried section during extended periods of system shutdown. This causes refrigerant slugging and could possibly damage the compressor at start-up.

## INTRODUCTION

This Service Manual provides the necessary information to service, repair, and maintain the 38-40MA family of Puron air conditioners and heat pumps. Section 2 of this manual has an appendix with data required to perform troubleshooting. Use the Table of Contents to locate a desired topic.

# MODEL / SERIAL NUMBER NOMENCLATURES

Size	Voltage	Outdoor Model	Indoor Model
9	115//60	38MAQB09---1	40MAQB09B--1
12		38MAQB12---1	40MAQB12B--1
9	208-230//60	38MAQB09---3	40MAQB09B--3
12		38MAQB12---3	40MAQB12B--3
18		38MAQB18---3	40MAQB18B--3
24		38MAQB24---3	40MAQB24B--3
30		38MAQB30---3	40MAQB30B--3

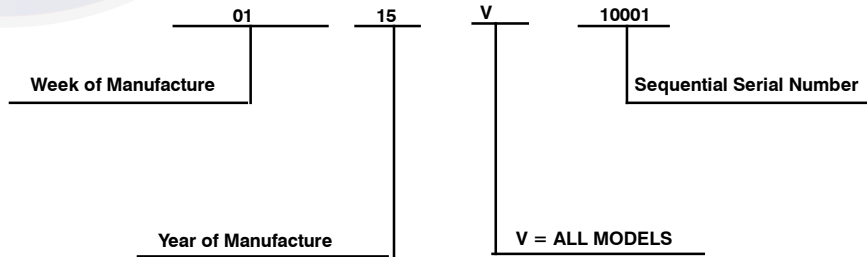
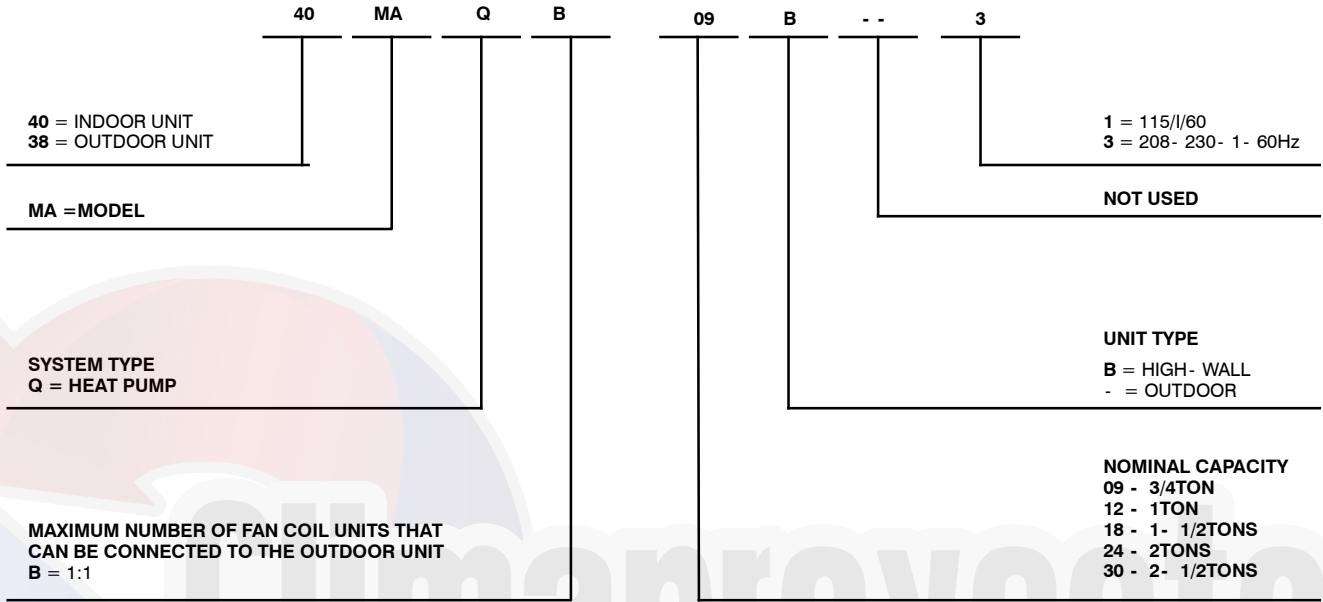

Use of the AHRI Certified TM Mark indicates a manufacturer's participation in the program For verification of certification for individual products, go to [www.ahridirectory.org](http://www.ahridirectory.org).



## STANDARD FEATURES AND ACCESSORIES

<b>Ease Of Installation</b>	
Mounting Brackets	S
Low Voltage Controls	S
<b>Comfort Features</b>	
Microprocessor Controls	S
Wired Remote Control	A
Wireless Remote Control	S
Automatic Horizontal Air Sweep	S
Air Direction Control	S
Auto Restart Function	S
Cold Blow Protection On Heat Pumps	S
Freeze Protection Mode On Heat Pumps	S
Turbo Mode	S
Silence Mode	S
Auto Changeover On Heat Pumps	S
Follow Me	S
<b>Energy Saving Features</b>	
Sleep Mode	S
Stop/Start Timer	S
46° F Heating Mode (Heating Setback)	S
<b>Safety And Reliability</b>	
3 Minute Time Delay For Compressor	S
Over Current Protection For Compressor	S
Indoor Coil Freeze Protection	S
Indoor Coil High Temp Protection in Heating Mode	S
Condenser High Temp Protection in Cooling Mode	S
<b>Ease Of Service And Maintenance</b>	
Cleanable Filters	S
Diagnostics	S
Liquid Line Pressure Taps	S
<b>Application Flexibility</b>	
Condensate Pumps	A
Crankcase Heater	S

**Legend**  
 S Standard  
 A Accessory

## INDOOR UNITS

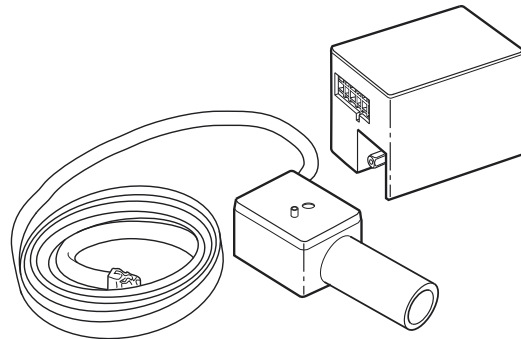

**Fig. 1 – Condensate Pump Accessory**

On high wall fan coils, the condensate pump has a lift capability of 12 ft (3.6 m) on the discharge side with the pump mounted in the fan coil or 6 ft (1.8 m) on the suction side if the pump is remote mounted. The pump is recommended when adequate drain line pitch cannot be provided, or when the condensate must move up to exit.

**NOTE:** An external 115v power source will be required to run the pump on unit sizes 9k and 12k.

## OUTDOOR UNITS

### Crankcase Heater

Standard on all unit sizes. Heater clamps around compressor oil stump.

# SPECIFICATIONS - HEAT PUMP ONLY UNITS (MAQ SERIES)

System	Size		9	12	9	12	18	24	30
		Outdoor Model		38MAQB09--1	38MAQB12--1	38MAQB09--3	38MAQB12--3	38MAQB18--3	38MAQB24--3
	Indoor Model		40MAQB09B--1	40MAQB12B--1	40MAQB09B--3	40MAQB12B--3	40MAQB18B--3	40MAQB24B--3	40MAQB30B--3
	Energy Star		YES	YES	YES	YES	YES	YES	NO
Performance	Cooling Rated Capacity	Btu/h	9,000	12,000	9,000	12,000	17,500	23,000	30,000
	Cooling Cap. Range Min - Max	Btu/h	3500~11000	4000~13000	3500~11000	4000~13000	4500~18000	5500~23500	8000~30500
	SEER		23.5	21.5	23.5	21.5	19.5	20.0	16.5
	EER		14.5	13	14.5	13	12.5	12.5	9.5
	Heating Rated Capacity	Btu/h	10,000	12,000	10,000	12,000	18,000	25,000	32,000
	Heating Cap. Range Min - Max	Btu/h	4,500~11,500	5,000~13,500	4,500~11,500	5,000~13,500	5,500~19,000	6,000~26,000	9,000~34,000
	HSPF		10.0	10.0	10.0	10.0	9.6	10.0	9.6
	COP	W/W	3.36	3.22	3.66	3.36	3.36	3.22	2.92
Controls	Wireless Remote Controller (*F/*C Convertible)		Standard						
	Wired Remote Controller (*F/*C Convertible)		Optional						
Operating Range	Cooling Outdoor DB Min - Max	*F	4~122	4~122	4~122	4~122	4~122	4~122	4~122
	Heating Outdoor DB Min - Max	*F	4~86	4~86	4~86	4~86	4~86	4~86	4~86
	Cooling Indoor DB Min -Max	*F	63~90	63~90	63~90	63~90	63~90	63~90	63~90
	Heating Indoor DB Min -Max	*F	32~86	32~86	32~86	32~86	32~86	32~86	32~86
Piping	Total Piping Length	Ft.	82	82	82	82	98	98	164
	Piping Lift	Ft.	32	32	32	32	65	65	82
	Pipe Connection Size - Liquid	In.	1/4	1/4	1/4	1/4	1/4	3/8	3/8
	Pipe Connection Size - Suction	In.	3/8	1/2	3/8	1/2	1/2	5/8	5/8
Refrigerant	Type		R410A						
	Design Pressure	PSIG	550	550	550	550	550	550	550
	Metering Device		EEV	EEV	EEV	EEV	EEV	Capillary Tube	Capillary Tube
Refrigerant	Charge	Lb.	2.76	2.76	2.76	2.76	4.19	5.18	6.62
Outdoor Coil	Face Area	Sq. Ft.	9.2	9.2	9.2	9.2	16.0	21.1	17.2
	No. Rows		2	2	2	2	2	3	3
	Fins per inch		21	21	21	21	18	18	17
	Circuits		4	4	4	4	6	8	6
Indoor Coil	Face Area (sq. ft.)	Sq. Ft.	2.2	2.2	2.2	2.2	2.6	3.7	3.7
	No. Rows		2	2	2	2	2	3	3
	Fins per inch		20	20	20	20	20	18	18
	Circuits		3	3	3	3	4	7	7
Compressor	Type		Hermetic Rotary DC Inverter Compressor						
	Model		ASM98D1UFZA	ASM108D1UFZA	ASM98D1UFZA	ASM108D1UFZA	ASM135D23UFZ	DA250S2C-30MT	TNB306FPGMC-L
	Oil Type		VG74	VG74	VG74	VG74	VG74	VG74	FV50S
	Oil Charge	Fl. Oz.	12.5	12.5	12.5	12.5	15.2	27.7	36.2
	Rated Current	RLA	5.3	5.7	5.3	5.7	7.3	8.8	13.5
Electrical	Voltage, Phase, Cycle	V/Ph/H z	115-1-60	115-1-60	208/230-1-60	208/230-1-60	208/230-1-60	208/230-1-60	208/230-1-60
	Power Supply		Indoor unit powered from outdoor unit						
	MCA	A.	15	15	15	15	15	15	20
	MOCP - Fuse Rating	A.	20	20	15	15	20	25	30
Outdoor	Unit Width	In.	31.9	31.9	.9	31.9	33.3	37.2	37.2
	Unit Height	In.	22.0	22.0	.0	22.0	.6	31.9	31.9
	Unit Depth	In.	12.2	12.2	.2	12.2	.6	15.6	15.6
	Net Weight	Lbs.	82.5	82.5	82.5	82.5	102.5	137.6	157.6
	Airflow	CFM	1200	1200	1200	1200	1390	1210	2130
	Sound Pressure	dB(A)	56	56	56	56	59	60	63
Indoor	Unit Width	In.	32.9	32.9	32.9	32.9	39.0	46.7	46.7
	Unit Height	In.	11.0	11.0	11.0	11.0	12.4	13.4	13.4
	Unit Depth	In.	7.8	7.8	7.8	7.8	8.6	10.2	10.2
	Net Weight	Lbs.	19.2	19.2	19.2	19.2	26.5	40.1	40.1
	Number of Fan Speeds		4	4	4	4	4	4	4
	Airflow (lowest to highest)	CFM	210/290/360/380	210/300/360/380	210/290/360/380	210/300/360/380	310/450/650/680	520/620/780/870	520/620/780/870
	Sound Pressure (lowest to highest)	dB(A)	27/34/42	27/34/42	27/34/42	27/34/42	33/40/46	39/45/50	39/45/50
Air throw Data	Ft.	23	23	23	23	30	36	36	

**Legend**

- SEER** - Seasonal Energy Efficiency Ratio
- EER** - Energy Efficiency Ratio
- MCA** - Minimum Circuit Amps
- MOCP** - Max. Over-Current Protection



## DIMENSIONS - INDOOR

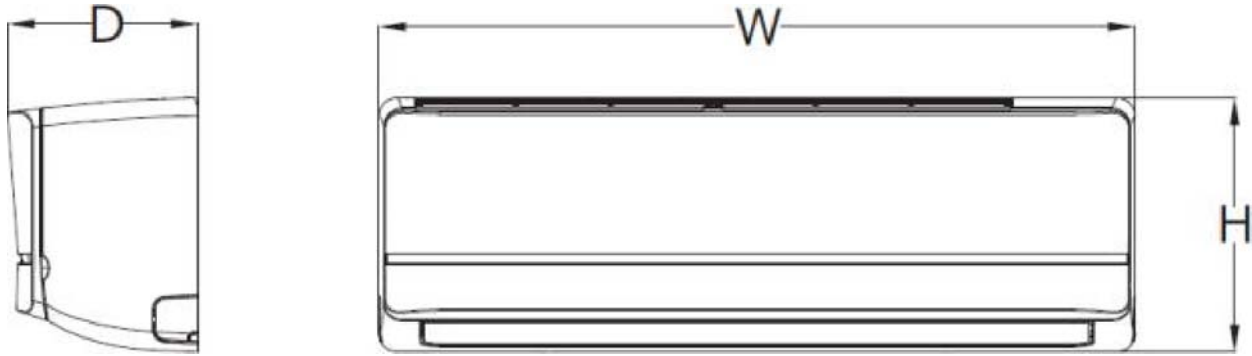

Fig. 2 – Indoor units

Unit Size	W in (mm)	D in (mm)	H in (mm)	Operating Weight lb (kg)
9K/12K	32.9 (835)	7.8 (198)	11.0 (280)	19.2 (8.7)
18K	39.0 (990)	8.6 (218)	12.4 (315)	26.5 (12.0)
24K/30K	46.7 (1186)	10.2 (258)	13.4 (343)	40.8 (18.5)



# DIMENSIONS - OUTDOOR

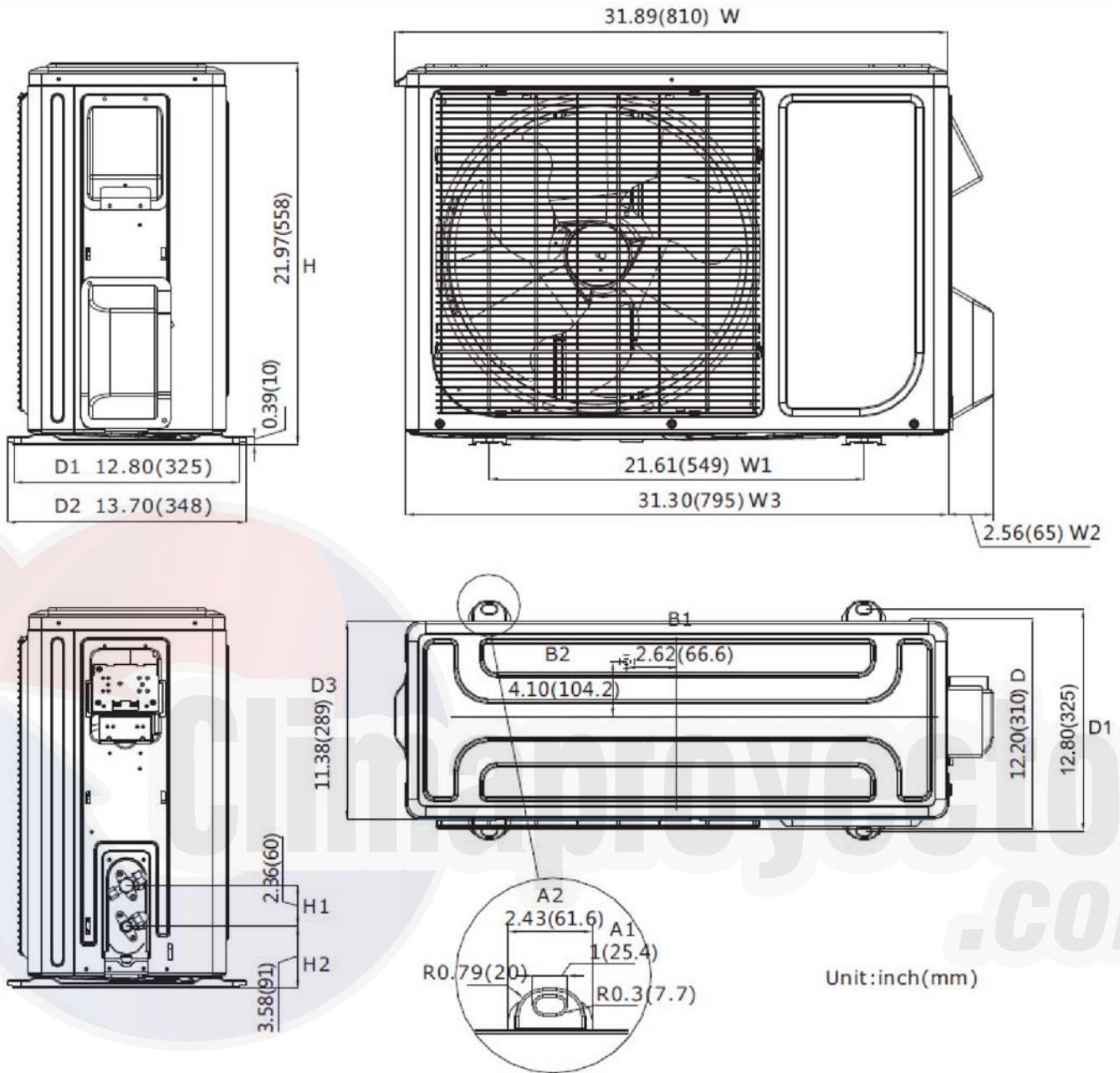

Fig. 3 – Outdoor Unit Sizes 09 and 12

Model	W in (mm)	D1 in (mm)	H in (mm)	W1 in (mm)	D1 in (mm)	Operating Weight lb (kg)
9K/12K	32.0 (810)	12.2 (310)	22.0 (558)	20.9 (530)	11.4 (290)	82.5 (37.4)
18K	33.2 (845)	13.2 (335)	27.6 (700)	22.1 (560)	13.2 (335)	102.5 (46.5)
24K	37.2 (945)	15.9 (405)	31.9 (810)	25.2 (640)	15.9 (405)	137.6 (62.4)
30K	37.2 (945)	15.9 (405)	31.9 (810)	25.2 (640)	15.9 (405)	157.6 (71.5)

# DIMENSIONS - OUTDOOR (CONTINUED)

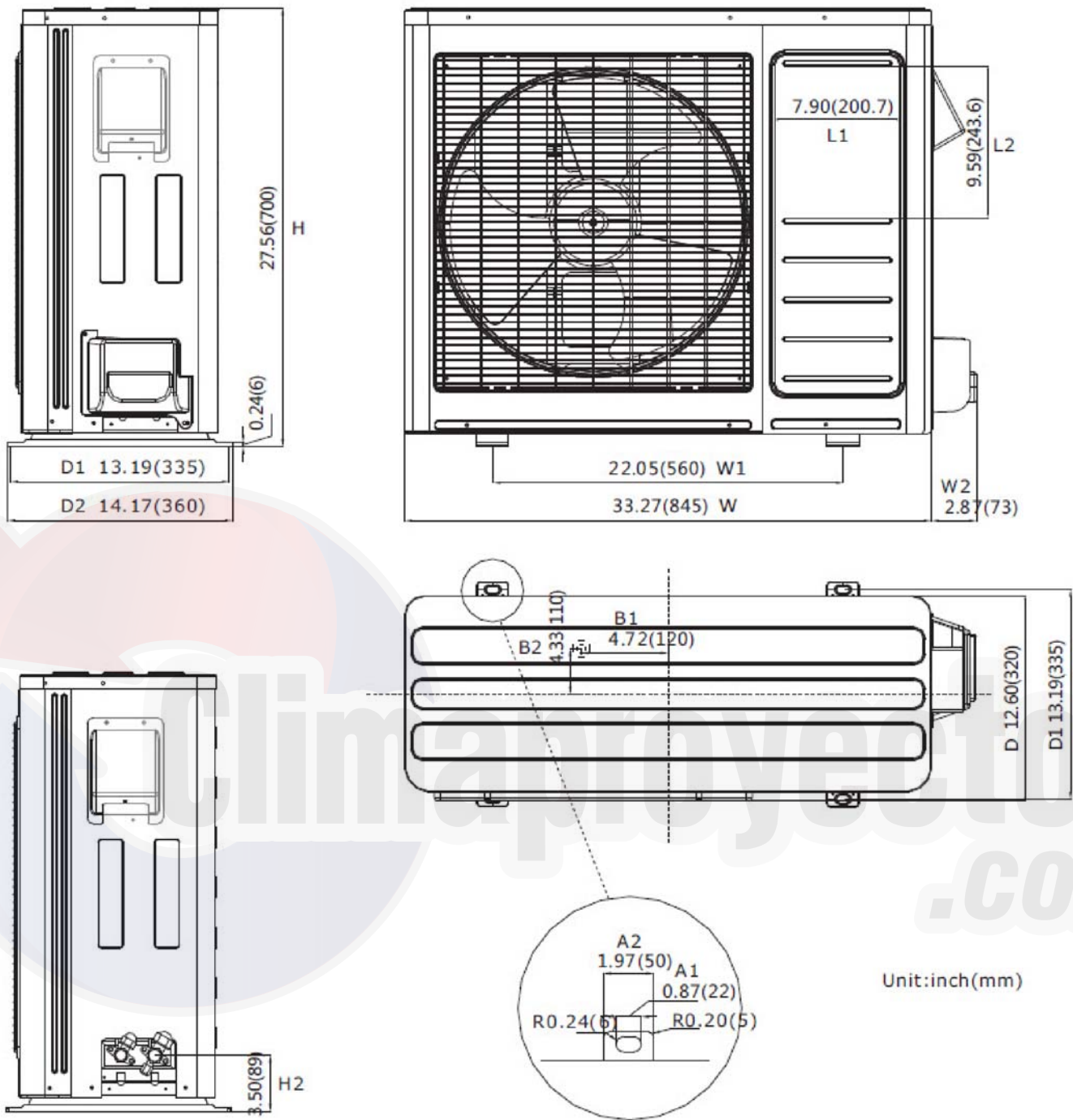
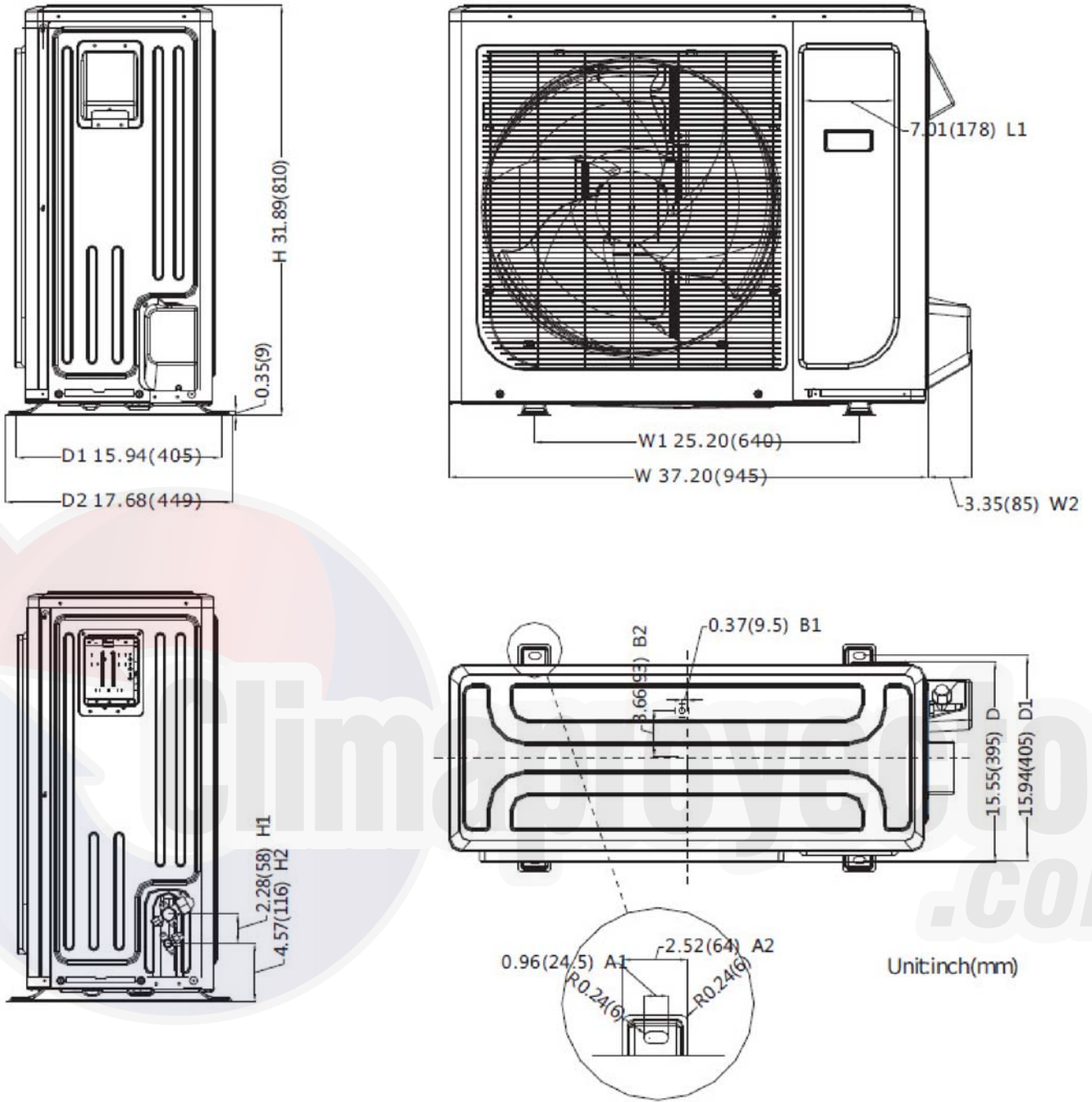

Fig. 4 – Outdoor Units Size 18

**DIMENSIONS - OUTDOOR (CONTINUED)**



**Fig. 5 – Outdoor Units Size 24 and 30**

## CLEARANCES - INDOOR

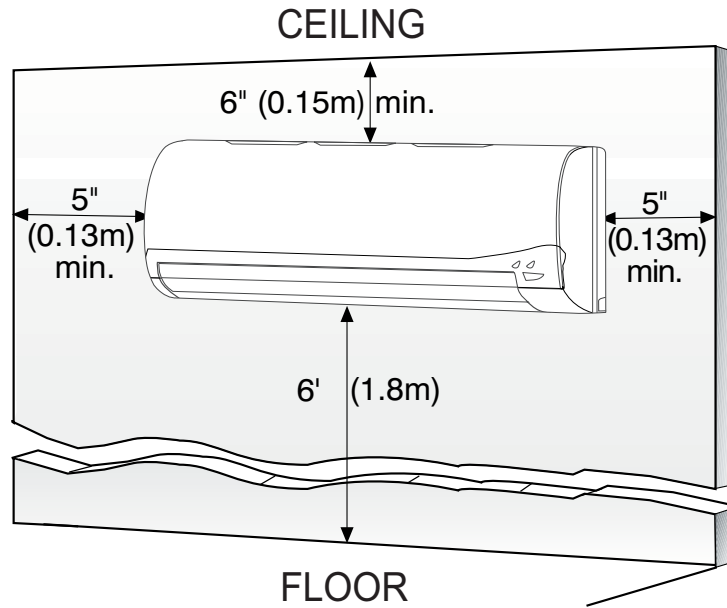

Fig. 6 – Indoor Unit Clearance

## CLEARANCES - OUTDOOR

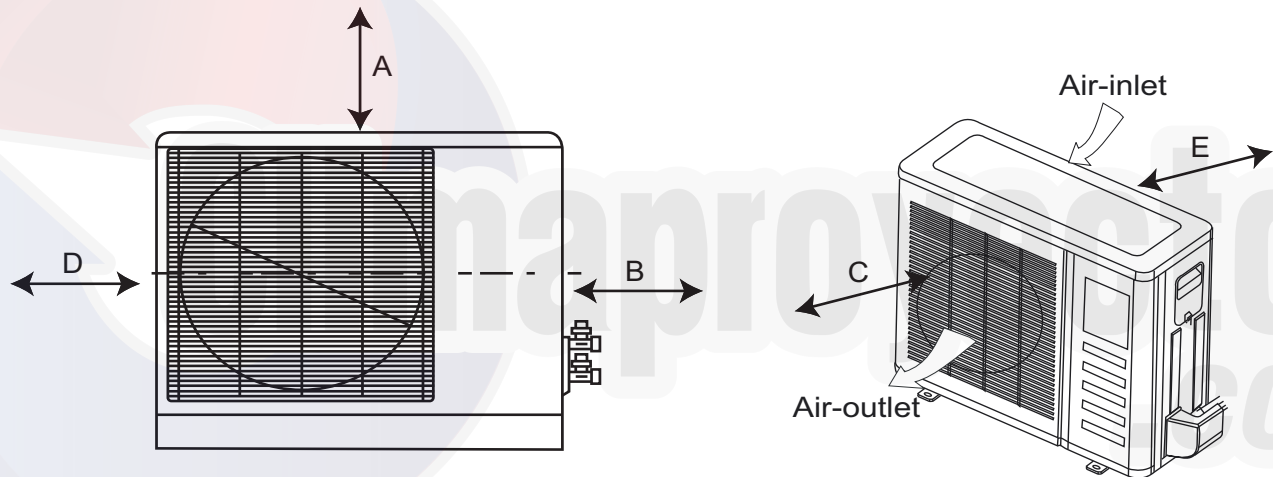

Fig. 7 – Outdoor Unit Clearance

UNIT	Minimum Value in. (mm)
A	24 (609)
B	24 (609)
C	24 (609)
D	4 (101)
E	4 (101)

## ELECTRICAL DATA

UNIT SIZE	OPER. VOLTAGE MAX / MIN*	COMPRESSOR		OUTDOOR FAN				INDOOR FAN				MCA	MAX FUSE CB AMP
		V/PH/HZ	RLA	V/PH/HZ	FLA	HP	W	V/PH/HZ	FLA	HP	W		
9K	127 / 104	115/1/60	5.3	115/1/60	0.14	0.053	40	115/1/60	0.17	0.027	20	15	20
12K			5.7										
9K	253 / 187	208-230/1/60	5.3	208-230/1/60	0.42	0.053	40	208-230/1/60	0.07	0.027	20	15	15
12K			5.70		0.42	0.053	40		0.07	0.027	20	15	
18K			7.3		0.95	0.067	50		0.17	0.077	58	15	20
24K			8.8		0.47	0.16	120		0.23	0.080	60	15	25
30K			13.5		1.21	0.16	120		0.23	0.080	60	20	30

\*Permissible limits of the voltage range at which the unit will operate satisfactorily.

### LEGEND

FLA - Full Load Amps

MCA - Minimum Circuit Amps

RLA - Rated Load Amps

## WIRING

### Recommended Connection Method for Power and Communication Wiring (To minimize communication wiring interference)

#### Power Wiring:

The main power is supplied to the outdoor unit. The field supplied connecting cable from the outdoor unit to indoor unit consists of three (3) wires and provides the power for the indoor unit. Two wires are high voltage AC power and one is a ground wire.

Consult your local building codes and the NEC (National Electrical Code) or CEC (Canadian Electrical Code) for special requirements.

All wires must be sized per NEC or CEC and local codes. Use Electrical Data table MCA (minimum circuit amps) and MOCP (maximum over current protection) to correctly size the wires and the disconnect fuse or breakers respectively.

Per caution note, only copper conductors with a minimum 300 volt rating and 2/64- inch thick insulation must be used.

#### Communication Wiring:

A separate shielded copper conductor only, with a minimum 300 volt rating and 2/64- inch thick insulation, must be used as the communication wire from the outdoor unit to the indoor unit.

To minimize voltage drop of the control wire, the factory recommendation is 14/3 wire with a ground. In special instances, where there is high electrical interferences, use a separate 16ga shielded wire to ensure proper communication.

The main power is supplied to the outdoor unit. The field supplied connecting cable from the outdoor unit to indoor unit consists of four (4) wires and provides the power and communication signals for the indoor unit. Two conductors are for power wiring (L1/L2, or L/N), one is a ground wire, and one is a DC communication wire.

Consult your local building codes and the NEC (National Electrical Code) or CEC (Canadian Electrical Code) for special requirements. All power wires must be sized per NEC or CEC and local codes. Use Electrical Data table MCA (minimum circuit amps) and MOCP (maximum over current protection) to correctly size the wires and the disconnect fuse or breakers respectively.

Per caution note, only copper conductors with a minimum 300 volt rating and 2/64- inch thick insulation must be used.

**CAUTION**

**EQUIPMENT DAMAGE HAZARD**

Failure to follow this caution may result in equipment damage or improper operation.

- Wires should be sized based on NEC and local codes.
- Use copper conductors only with a minimum 300 volt rating and 2/64 inch thick insulation.

**CAUTION**

**EQUIPMENT DAMAGE HAZARD**

Failure to follow this caution may result in equipment damage or improper operation.

- Be sure to comply with local codes while running wire from indoor unit to outdoor unit.
- Every wire must be connected firmly. Loose wiring may cause terminal to overheat or result in unit malfunction. A fire hazard may also exist. Therefore, be sure all wiring is tightly connected.
- No wire should be allowed to touch refrigerant tubing compressor or any moving parts.
- Disconnecting means must be provided and shall be located within sight and readily accessible from the air conditioner.
- Connecting cable with conduit shall be routed through hole in the conduit panel.



# CONNECTION DIAGRAMS

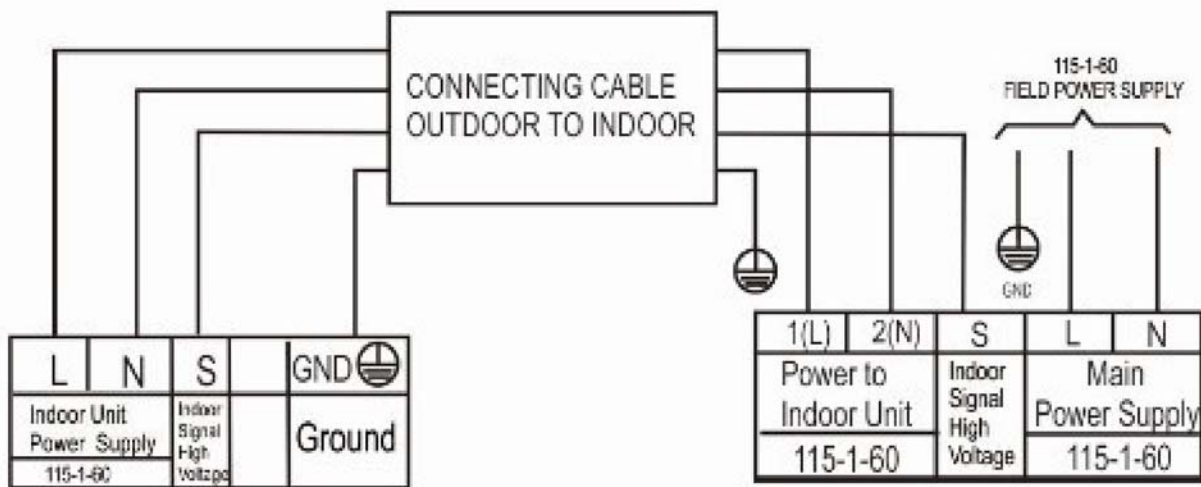

Fig. 8 – 115V

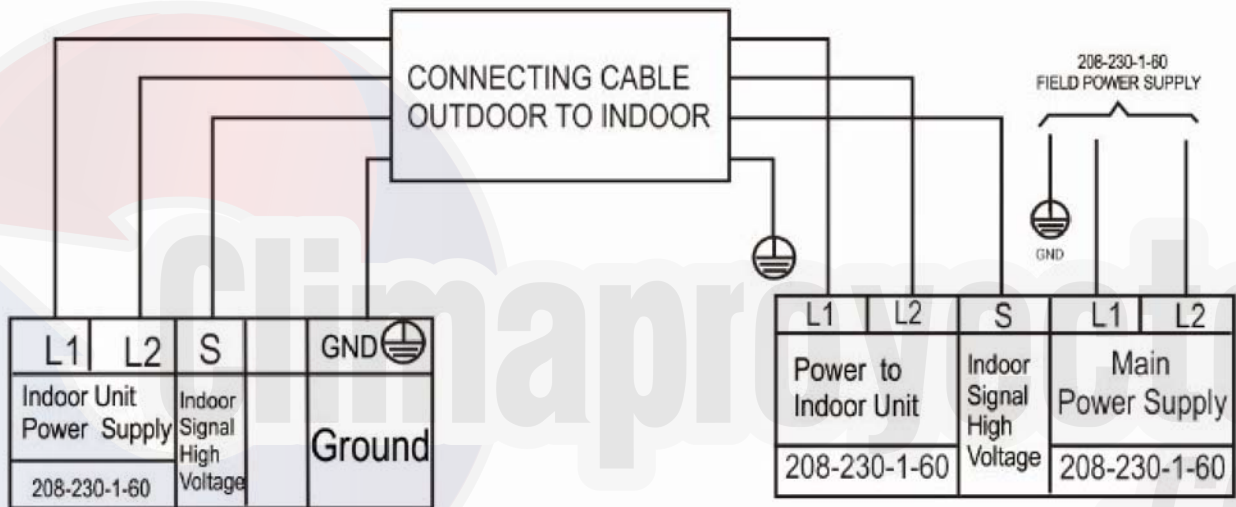

Fig. 9 – 208-230V

**Notes:**

1. Do not use thermostat wire for any connection between indoor and outdoor units.
2. All connections between indoor and outdoor units must be as shown. **The connections are sensitive to polarity and will result in a fault code.**



# WIRING DIAGRAMS

## Indoor Unit

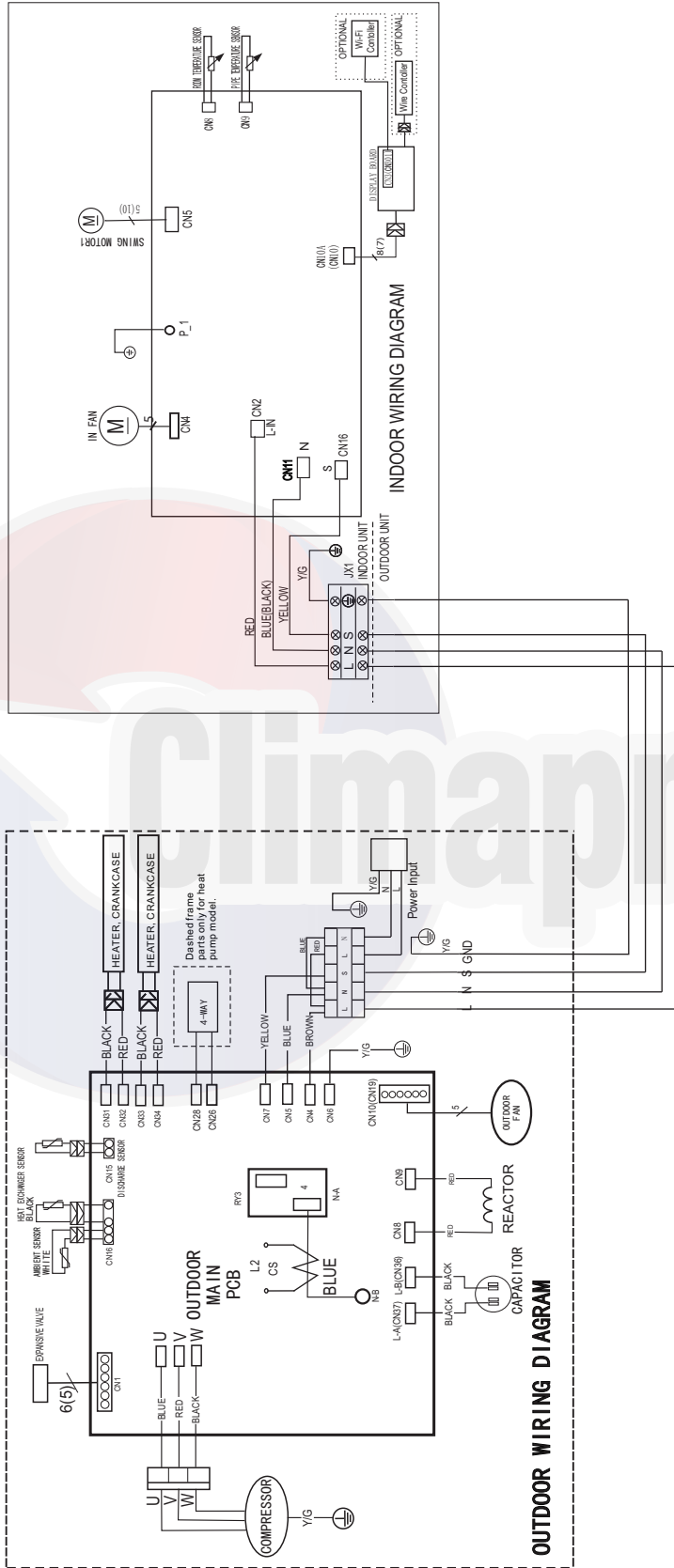

Fig. 10 – Wiring Diagram Sizes 09- 12 (115V)

INDOOR UNIT CONTROL BOARD	
INPUT or OUTPUT VALUE	
L,IN	Power Voltage : AC 115V
CN11	Power Voltage : AC115V
CN16	Relative to the N terminal voltage : DC 24V
CN15	Maximum voltage : DC5V
CN4	Indoor fan interface,Maximum voltage : DC310V
CN5	Stepper motor interface,Maximum voltage between the lines : DC12V
P_1	Ground
CN8	Room temperature sensor interface, maximum voltage : DC5V
CN9	Pipe temperature sensor interface, maximum voltage : DC5V
CN10A	Display interface, maximum voltage between the lines : DC5V
OUTDOOR UNIT CONTROL BOARD	
PART NAME	
CN1	OutputPins&6(2V) Pm1-Pm4:Pulse waveform(0-12V)
CN15	InputPm1-Pm2(0-1.8V)
CN16	Input: Pm1-Pm3 -Pm4:Pins(0-1.8V)
CN19	OutputPm1 -Pm5(0-115V High voltage)
CN31,CN33	Output115VAC High voltage
CN32,CN34	Output115VAC High voltage
CN26,CN28	Output115VAC for 4-way control
CN4	Input:115 VAC High voltage
CN5	Input:115 VAC High voltage
CN6	Connection to the earth
CN7	Output: Connection of the high voltage
CN8,CN9	Output: High voltage
CN36,CN37	Output: High voltage
N-B	Output: High voltage
UV,W	Output: Pulse(0-320VDC)

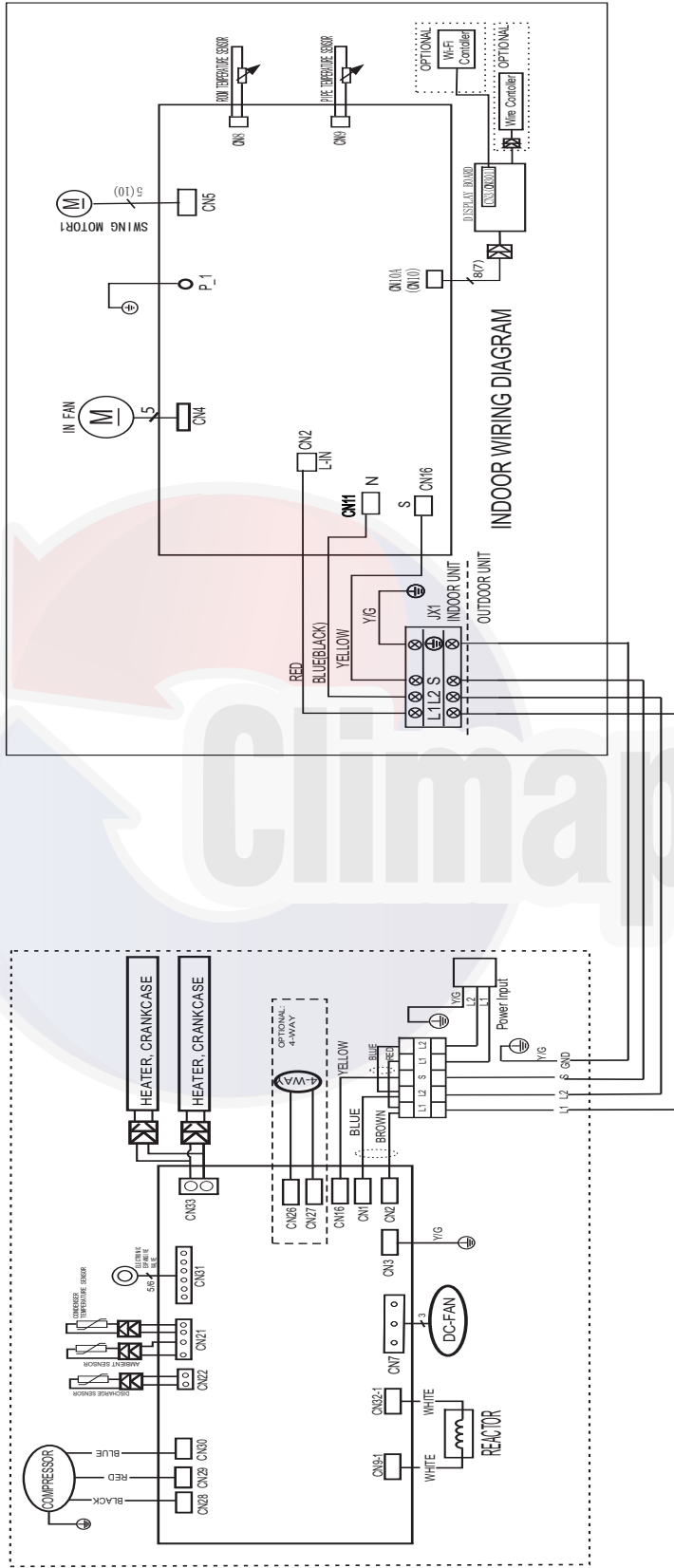

Fig. 11 – Wiring Diagram Sizes 09-12 (208-230V)

**INDOOR UNIT CONTROL BOARD**

	INPUT or OUTPUT VALUE
L_IN	Power Voltage : AC 230V
CN11	Power Voltage : AC 230V
CN16	Relative to the N terminal voltage : DC 24V
CN15	Maximum voltage : DC 5V
CN4	Indoor fan interface, Maximum voltage : DC 310V
CN5	Stepper motor interface, Maximum voltage between the lines : DC 12V
P_1	Ground
CN8	Room temperature sensor interface, maximum voltage : DC 5V
CN9	Pipe temperature sensor interface, maximum voltage : DC 5V
CN10A	Display interface, maximum voltage between the lines : DC 5V

**OUTDOOR UNIT CONTROL BOARD**

	INPUT or OUTPUT VALUE
CN31	Output, Pin5&6 (12V) Pin1-Pin4, Pulse waveform, (0-12V)
CN21	Input, Pin3-4 (3.3V) Pin2(0V), Pin1, Pin5(0-3.3V)
CN22	Input, Pin1 (3.3V) Pin2(0-3.3V)
CN37	Output, 230VAC High voltage
CN9-1, CN32-1	Output, Connection of the high voltage
CN1	Input, 230VAC High voltage
CN2	Input, 230 VAC High voltage
CN3	Connection to the earth
CN16	Output, Connection of the high voltage
CN26, CN27	Output, High voltage for 4-way control
CN7	Output, Pulse(0-320VDC) for DC FAN
U V W	Output, Pulse(0-320VDC) for COMPRESSOR

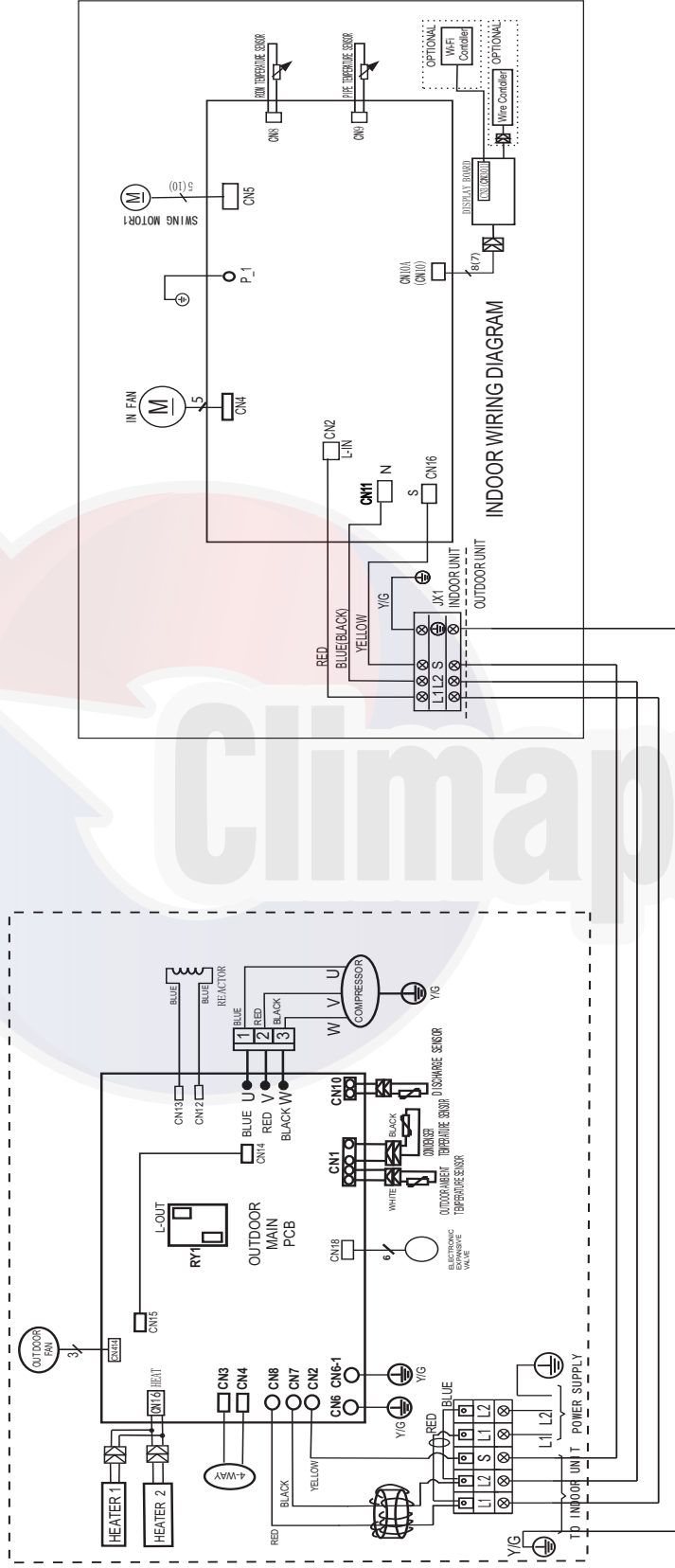

Fig. 12 – Wiring Diagram Size 18 (208-230V)

**INDOOR UNIT CONTROL BOARD**

	INPUT or OUTPUT VALUE
L,IN	Power Voltage : AC 230V
CN11	Power Voltage : AC230V
CN16	Relative to the N terminal voltage : DC 24V
CN15	Maximum voltage : DC5V
CN4	Indoor fan interface Maximum voltage : DC3.10V
CN5	Stepper motor interface Maximum voltage between the lines : DC12V
P_1	Ground
CN8	Room temperature sensor interface maximum voltage : DC5V
CN9	Pipe temperature sensor interface maximum voltage : DC5V
CN10A	Display interface maximum voltage between the lines : DC5V

**OUTDOOR UNIT CONTROL BOARD**

	INPUT or OUTPUT VALUE
CN7、CN8	Input: 230V High voltage
CN2	Output: Connection of the high voltage
CN3、CN4	Output: High voltage for 4-way control
CN11、CN16	Output: 230V High voltage for HEATER
CN5	Output: Pulse(0-320V) for DC FAN
CN12、CN13	Output: Connection of the high voltage
U V W	Output: Pulse(0-320V) for compressor
CN10	Input:Pin1 (5V) Pin2(0-5V)
CN1	Input:Pin3-4 (5V) Pin2(0V),Pin1,Pin5(0-5V)
CN18	Output:Pin5&6(2V) Pin1-Pin4:Pulse waveform,(0-12V)

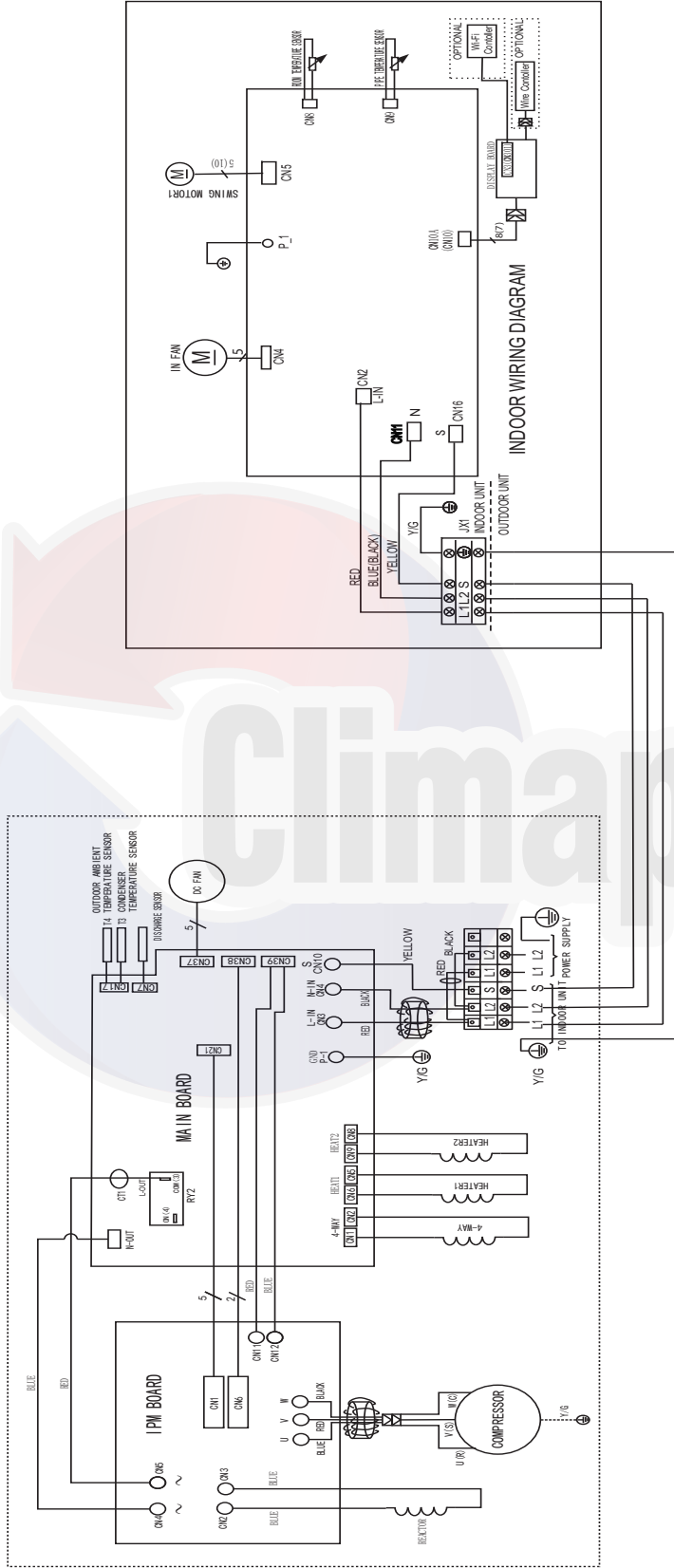

Fig. 13 – Wiring Diagram Size 24 (208-230V)

**INDOOR UNIT CONTROL BOARD**

	INPUT or OUTPUT VALUE
L_IN	Power Voltage : AC 230V
CN11	Power Voltage : AC230V
CN16	Relative to the N terminal voltage : DC 24V
CN15	Maximum voltage : DC5V
CN4	Indoor fan interface Maximum voltage : DC3.10V
CN5	Stepper motor interface Maximum voltage between the lines : DC12V
P_1	Ground
CN8	Room temperature sensor interface maximum voltage : DC5V
CN9	Pipe temperature sensor interface maximum voltage : DC5V
CN10A	Display interface maximum voltage between the lines : DC5V

**OUTDOOR UNIT CONTROL BOARD**

	INPUT or OUTPUT VALUE
L_IN	Power Voltage : AC 230V
CN11	Power Voltage : AC230V
CN16	Relative to the N terminal voltage : DC 24V
CN15	Maximum voltage : DC5V
CN6	Maximum output voltage : AC230V
CN4	Indoor fan interface Maximum voltage : DC3.10V
CN5	Stepper motor interface Maximum voltage between the lines : DC12V
P_1	Ground
CN8	Room temperature sensor interface maximum voltage : DC5V
CN9	Pipe temperature sensor interface maximum voltage : DC5V
CN10A	Display interface maximum voltage between the lines : DC5V
CN14	Stepper motor interface (optional) maximum voltage between the lines : DC12V

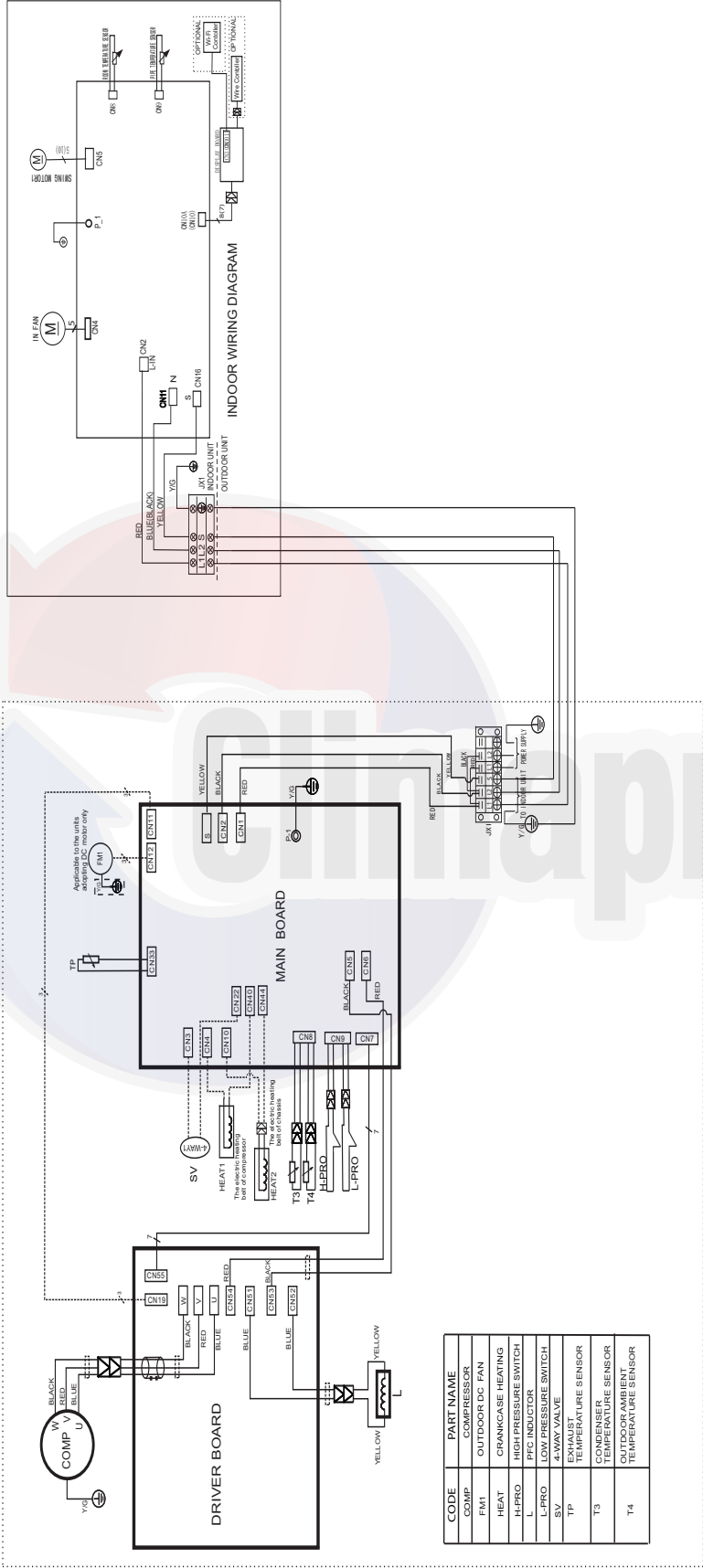

Fig. 14 – Wiring Diagram Size 30 (208-230V)

**INDOOR UNIT CONTROL BOARD**

INPUT or OUTPUT VALUE
L IN Power Voltage : AC 230V
CN11 Power Voltage : AC230V
CN16 Relative to the N terminal voltage : DC 24V
CN15 Maximum voltage : DC5V
CN4 Indoor fan interface.Maximum voltage : DC310V
CN5 Stepper motor interface.Maximum voltage between the lines : DC12V
P-1 Ground
CN8 Room temperature sensor interface.maximum voltage : DC5V
CN9 Pipe temperature sensor interface maximum voltage : DC5V
CN10A Display interface maximum voltage between the lines : DC5V

**OUTDOOR UNIT CONTROL BOARD**

INPUT or OUTPUT VALUE
CN1, CN2 Input: 230V High voltage
S Output: Connection of the high voltage
CN11, CN12 Output: Pulse(0-320V) for DC FAN
CN33 Input:Pin1 (5V) Pin2(0-5V)
CN3, CN22 Output: High voltage for 4-way control
CN4, CN40 Output: 230V High voltage for HEATER1
CN10, CN44 Output: 230V High voltage for HEATER2
CN8 Input:Pin3-4 (5V) Pin2(0V),Pin1,Pin5(0-5V)
CN9 Input:Pin1-3 (0V) Pin2-4(0-5V)
CN51 CN52 Output: Connection of the high voltage
U V W Output: Pulse(0-380V) for compressor

# FAN AND MOTOR SPECIFICATIONS

System size		9K (115V)	12K (115V)	9K (208-230 V)	12K (208-230 V)	18K (208-230 V)	24K (208-230 V)	30K (208-230 V)
Indoor fan	material	AS	AS	AS	AS	AS	AS	AS
	Type	GL-98*655-N	GL-98*655-N	GL-98*655-N	GL-98*655-N	GL-107.5*760-IN	GL-118*895-IN	GL-118*895-IN
	Diameter	inch 98	inch 98	inch 98	inch 98	107.5	118	118
	Height	inch 655	inch 655	inch 655	inch 655	760	895	895
Outdoor fan	material	AS	AS	AS	AS	AS	AS	AS
	Type	ZL-421*117*8-3K	ZL-421*117*8-3K	ZL-421*117*8-3K	ZL-421*117*8-3K	ZL-460*180*10-3N	ZL-560*139*12-3KN	ZL-560*139*12-3KN
	Diameter	inch 421	inch 421	inch 421	inch 421	460	560	560
	Height	inch 117	inch 117	inch 117	inch 117	180	139	139
Indoor fan motor	Model	WZDK20-38M	WZDK20-38M	WZDK20-38G	WZDK20-38G	WZDK58-38G	WZDK60-38G	WZDK60-38G
	Type	DC	DC	DC	DC	DC	DC	DC
	Phase	3	3	3	3	3	3	3
	FLA	0.17	0.17	0.07	0.07	0.17	0.23	0.23
	Insulation class	E	E	E	E	E	E	E
	Safe class	IPX0	IPX0	IPX0	IPX0	IPX0	IPX0	IPX0
	Input	W 25	W 25	W 22	W 22	W 52	W 72	W 72
	Output	W 20	W 20	W 20	W 20	W 58	W 60	W 60
	Range of current	Amps 0.17±10%	Amps 0.17±10%	Amps 0.07±10%	Amps 0.07±10%	Amps 0.17±10%	Amps 0.23±10%	Amps 0.23±10%
	Rated current	Amps 0.17	Amps 0.17	Amps 0.07	Amps 0.07	Amps 0.17	Amps 0.23	Amps 0.23
	Rated HP	HP 0.027	HP 0.027	HP 0.027	HP 0.027	HP 0.077	HP 0.08	HP 0.08
	Speed	rev/m in 1300/1170/900/700	rev/m in 1300/1170/900/700	rev/m in 1300/1170/900/700	rev/m in 1300/1170/900/700	rev/m in 1300/1170/900/700	rev/m in 1250/1200/1100/900	rev/m in 250/1200/1100/900
	Rated RPM	rev/m in 1350	rev/m in 1350	rev/m in 1350	rev/m in 1350	rev/m in 1350	rev/m in 1350	rev/m in 1350
	Max. input	W 25	W 25	W 22	W 22	W 52	W 72	W 72
Outdoor fan motor	Model	WZDK40-38G-1	WZDK40-38G-1	WZDK40-38G-W-1	WZDK40-38G-W-1	ZKFN-50-8-2	WZDK120-38G-1	WZDK120-38G-W
	Phase	3	3	3	3	3	3	3
	FLA	0.14	0.14	0.42	0.42	0.95	0.47	1.21
	Type	DC	DC	DC	DC	DC	DC	DC
	Insulation class	E	E	E	E	E	E	E
	Safe class	IPX0	IPX0	IPX0	IPX0	IPX0	IPX0	IPX0
	Input	W 42	W 42	W 46	W 46	W 116	W 145	W 150
	Output	W 40	W 40	W 40	W 40	W 50	W 120	W 120
	Range of current	Amps 0.14±10%	Amps 0.14±10%	Amps 0.42±10%	Amps 0.42±10%	Amps 0.95±10%	Amps 0.47±10%	Amps 1.21±10%
	Rated current	Amps 0.14	Amps 0.14	Amps 0.42	Amps 0.42	Amps 0.95	Amps 0.47	Amps 1.21
	Rated HP	HP 0.053	HP 0.053	HP 0.053	HP 0.053	HP 0.067	HP 0.16	HP 0.16
	Speed	rev/m in 800/700/600	rev/m in 800/700/600	rev/m in 800/700/600	rev/m in 800/700/600	rev/m in 800/700/600	rev/m in 850/750/700	rev/m in 850/800/750
	Rated RPM	rev/m in 900	rev/m in 900	rev/m in 900	rev/m in 900	rev/m in 900	rev/m in 1050	rev/m in 1050
	Max. input	W 42	W 42	W 46	W 46	W 116	W 145	W 150

## SOUND DATA SPECIFICATION

System Size		9K (115V)	12K (115V)	9K (208-230V)	12K (208-230V)	18K (208-230V)	24K (208-230V)	30K (208-230V)
Indoor Sound Pressure cooling mode (at different speeds)	dBa	42/34/27	42/34/27	42/34/27	42/34/27	46.5/40/33	50/45/39	50/45/39
Indoor Sound Pressure heating mode (at different speeds)	dBa	40/33/26	41/34/27	40/33/26	41/34/27	45/39/32	47/44/38	47/44/38
Outdoor sound pressure level	dBa	55.5	56	55.5	56	59	60	63

## ENVIRONMENTAL SPECIFICATIONS

System size			9K	12K	9K	12K	18K	24K	30K
			(115V)	(115V)	(208-230V)	(208-230V)	(208-230V)	(208-230V)	(208-230V)
Operating Range	<b>Cooling</b>								
	Outdoor Min - Max DB	°F (°C)	4-122 (-20-50)	4-122 (-20-50)	4-122 (-20-50)	4-122 (-20-50)	4-122 (-20-50)	4-122 (-20-50)	4-122 (-20-50)
	Indoor Min - Max DB	°F (°C)	63-90 (17-32)	63-90 (17-32)	63-90 (17-32)	63-90 (17-32)	63-90 (17-32)	63-90 (17-32)	63-90 (17-32)
	Indoor Min - Max WB	°F (°C)	59-84 (15-29)	59-84 (15-29)	59-84 (15-29)	59-84 (15-29)	59-84 (15-29)	59-84 (15-29)	59-84 (15-29)
	<b>Heating</b>								
	Outdoor DB Min - Max	°F (°C)	4-86 (-20-30)	4-86 (-20-30)	4-86 (-20-30)	4-86 (-20-30)	4-86 (-20-30)	4-86 (-20-30)	4-86 (-20-30)
	Outdoor WB Min - Max	°F (°C)	4-77 (-20-25)	4-77 (-20-25)	4-77 (-20-25)	4-77 (-20-25)	4-77 (-20-25)	4-77 (-20-25)	4-77 (-20-25)
	Indoor DB Min -Max	°F (°C)	32-86 (0-30)	32-86 (0-30)	32-86 (0-30)	32-86 (0-30)	32-86 (0-30)	32-86 (0-30)	32-86 (0-30)
Non-operating environment	Temperature range (DB)	°F	32-86 (0-30)	32-86 (0-30)	32-86 (0-30)	32-86 (0-30)	32-86 (0-30)	32-86 (0-30)	32-86 (0-30)
		(°C)	32-86 (0-30)	32-86 (0-30)	32-86 (0-30)	32-86 (0-30)	32-86 (0-30)	32-86 (0-30)	32-86 (0-30)
Operation Humidity	%	0-80 %	0-80 %	0-80 %	0-80 %	0-80 %	0-80 %	0-80 %	
Ambient Humidity	%	0-80 %	0-80 %	0-80 %	0-80 %	0-80 %	0-80 %	0-80 %	

## AIRFLOW SPECIFICATIONS

System size		9K	12K	9K	12K	18K	24K	30K
		(115V)	(115V)	(208-230V)	(208-230V)	(208-230V)	(208-230V)	(208-230V)
Indoor (CFM)	Turbo	380	380	380	380	680	870	870
	High	360	360	360	360	650	780	780
	Medium	290	300	290	300	450	620	620
	Low	210	210	210	210	310	520	520
Outdoor (CFM)		1200	1200	1200	1200	1390	2130	2130

## AIR THROW DATA

Unit Capacity	Max. Approximate Air Throw ft. (m)	Approximate Air Throw ft.(m) range
9K,12K	23 (7)	11 (3.5) ~ 23 (7)
18K	30 (9)	13 (4) ~ 30 (9)
24K	36 (11)	16 (5) ~ 36 (11)
30K	36 (11)	16 (5) ~ 36 (11)



# COOLING PERFORMANCE DATA

Model	Cooling			Outdoor conditions (DB)					
	Indoor Conditions DB	Indoor Conditions WB		77F(25C)	86F(30C)	95F(35C)	104F(40C)	113F(45C)	122F(50C)
09 (115V)	69.8F(21C)	59F(15C)	TC	7.43	7.83	9.74	8.38	6.11	5.11
			SC	6.68	6.69	8.18	7.37	4.36	3.74
			Input	0.35	0.54	0.81	0.8	0.75	0.75
	75.2F(24C)	62.6F(17C)	TC	7.78	9.14	9.89	8.65	6.92	5.83
			SC	3.58	8.11	6.27	5.52	4.85	4.29
			Input	0.35	0.54	0.81	0.8	0.75	0.75
	80.6F(27C)	66.2F(19C)	TC	8.21	9.22	10.41	9.27	7.32	6
			SC	7.39	5.88	8.22	7.79	5.11	4.37
			Input	0.35	0.75	0.82	0.81	0.75	0.75
	89.6F(32C)	73.4F(23C)	TC	8.41	9.72	11.59	10.22	8.82	7.51
			SC	3.68	5.76	6.9	6.2	5.55	5
			Input	0.36	0.56	0.83	0.82	0.76	0.77
12 (115V)	69.8F(21C)	59F(15C)	TC	8.21	11.75	11.42	9	7.85	6.68
			SC	7.06	9.05	8.68	7.38	6.42	5.58
			Input	0.38	0.8	1.04	0.87	0.82	0.81
	75.2F(24C)	62.6F(17C)	TC	8.42	11.84	12.01	9.35	8.32	7.34
			SC	7.28	8.69	8.66	7.62	6.53	5.81
			Input	0.57	0.94	1.25	1.27	0.98	0.94
	80.6F(27C)	66.2F(19C)	TC	8.81	11.95	12.23	9.69	8.87	7.95
			SC	7.49	8.32	8.63	7.85	6.64	6.04
			Input	0.39	0.75	1.06	0.89	0.85	0.82
	89.6F(32C)	73.4F(23C)	TC	9.01	12.15	12.43	9.89	9.07	8.15
			SC	7.7	8.53	8.84	8.06	6.85	6.25
			Input	0.4	0.97	1.3	1.34	0.92	0.85
09 (208-230V)	69.8F(21C)	59F(15C)	TC	7.41	7.82	9.73	8.34	6.12	5.1
			SC	6.64	6.69	8.18	7.37	4.36	3.74
			Input	0.35	0.54	0.81	0.8	0.75	0.75
	75.2F(24C)	62.6F(17C)	TC	7.76	9.16	9.89	8.62	6.92	5.83
			SC	3.58	8.11	6.27	5.52	4.85	4.29
			Input	0.35	0.54	0.81	0.8	0.75	0.75
	80.6F(27C)	66.2F(19C)	TC	8.21	9.22	10.41	9.27	7.32	6
			SC	7.39	5.88	8.22	7.79	5.11	4.37
			Input	0.35	0.75	0.82	0.81	0.75	0.75
	89.6F(32C)	73.4F(23C)	TC	8.41	9.72	11.59	10.22	8.82	7.51
			SC	3.68	5.76	6.9	6.2	5.55	5
			Input	0.36	0.56	0.83	0.82	0.76	0.77
12 (208-230V)	69.8F(21C)	59F(15C)	TC	8.21	11.75	11.42	9	7.85	6.68
			SC	7.06	9.05	8.68	7.38	6.42	5.58
			Input	0.38	0.8	1.04	0.87	0.82	0.81
	75.2F(24C)	62.6F(17C)	TC	8.42	11.84	12.01	9.35	8.32	7.34
			SC	7.28	8.69	8.66	7.62	6.53	5.81
			Input	0.57	0.94	1.25	1.27	0.98	0.94
	80.6F(27C)	66.2F(19C)	TC	8.81	11.95	12.23	9.69	8.87	7.95
			SC	7.49	8.32	8.63	7.85	6.64	6.04
			Input	0.39	0.75	1.06	0.89	0.85	0.82
	89.6F(32C)	73.4F(23C)	TC	9.01	12.15	12.43	9.89	9.07	8.15
			SC	7.7	8.53	8.84	8.06	6.85	6.25
			Input	0.4	0.97	1.3	1.34	0.92	0.85
18 (208-230V)	69.8F(21C)	59F(15C)	TC	12.58	15.24	16.25	11.04	8.32	6.78
			SC	8.34	10.3	10.6	7.93	6.18	5.16
			Input	0.58	0.93	1.53	1.2	1.42	1.32
	75.2F(24C)	62.6F(17C)	TC	13.48	16.41	16.66	12.3	9.43	7.74
			SC	8.85	10.94	11.35	8.62	6.87	5.91
			Input	0.57	0.93	1.56	1.22	1.45	1.35
	80.6F(27C)	66.2F(19C)	TC	14.43	18.04	18.37	13.35	9.97	7.96
			SC	9.59	11.95	12.37	9.28	7.23	6.02
			Input	0.57	0.94	1.59	1.24	1.48	1.38
	89.6F(32C)	73.4F(23C)	TC	14.7	19.03	20.18	15.36	12.02	9.97
			SC	9.08	11.72	12.5	9.69	7.85	6.89
			Input	0.6	0.97	1.62	1.27	1.51	1.41
24 (208-230V)	69.8F(21C)	59F(15C)	TC	19.5	20.69	21.43	18.05	14.27	13.32
			SC	15.15	15.61	15.49	14.23	10.03	8.78
			Input	1.2	1.88	2.29	2.14	1.9	1.86
	75.2F(24C)	62.6F(17C)	TC	20.01	21.21	22.31	18.51	15.08	13.3
			SC	15.25	15.71	15.59	14.33	10.13	8.88
			Input	1.2	1.87	2.3	2.21	2.14	1.92
	80.6F(27C)	66.2F(19C)	TC	20.54	21.75	23.21	18.98	15.91	13.3
			SC	15.35	15.81	15.69	14.43	10.23	8.98
			Input	1.21	1.86	2.31	2.26	2.16	1.93
	89.6F(32C)	73.4F(23C)	TC	20.61	22.94	24.4	21.84	19.17	16.66
			SC	15.58	16.04	15.92	14.66	10.46	9.21
			Input	1.22	1.87	2.34	2.33	2.32	1.96
30 (208-230V)	69.8F(21C)	59F(15C)	TC	27.33	27.43	27.51	22.77	18.29	17.32
			SC	19.4	19.48	19.56	17.21	16.32	15.28
			Input	2.28	3.29	3.63	3.11	2.35	2.25
	75.2F(24C)	62.6F(17C)	TC	29.41	30.01	29.82	24.53	20.71	18.24
			SC	19.95	20.47	20.07	17.73	17.24	16.29
			Input	2.31	3.32	3.68	3.17	2.41	2.31
	80.6F(27C)	66.2F(19C)	TC	31.57	32.68	32.21	26.37	23.2	19.21
			SC	20.55	21.52	20.65	18.3	18.21	17.35
			Input	2.35	3.35	3.74	3.23	2.47	2.38
	89.6F(32C)	73.4F(23C)	TC	32.6	33.71	33.24	27.4	24.23	20.24
			SC	20.9	21.87	21	18.65	18.56	17.7
			Input	2.42	3.42	3.81	3.3	2.54	2.45

## LEGEND

DB - Dry Bulb

WB - Wet Bulb

TC - Total Net Cooling Capacity (1000 Btu/hour)

SC - Sensible Capacity (1000 Btu/hour)

Input - Total power (kW)

# HEATING PERFORMANCE

Model	Heating		Outdoor conditions (DB)							
	Indoor Conditions DB		53.6F(12C)	44.6F(7C)	39.2F(4C)	32F(0C)	24.8F(-4C)	19.4F(-7C)	17F(-8C)	5F(-15C)
09(115V)	59F(15C)	TH	11.2	11.1	10.89	10.65	9.87	9.11	8.27	6.71
		Input	0.73	0.79	1.04	1.01	0.96	0.9	0.84	0.8
	64.4F(18C)	TH	11.1	10.8	10.65	10.54	9.63	8.84	8.01	5.46
		Input	0.78	0.8	1.08	1.03	0.98	0.94	0.9	0.82
	69F(20.5C)	TH	10.8	10.6	10.48	10.32	9.43	8.55	7.95	4.29
		Input	0.8	0.81	1.11	1.05	1	0.98	0.96	0.84
	71.6F(22C)	TH	10.6	10.3	10.21	10.11	9.23	8.41	7.89	4.11
		Input	0.82	0.83	1.15	1.07	1.02	1.02	0.92	0.86
12(115V)	59F(15C)	TH	11.8	12.7	12.42	11.32	10.4	9.54	8.9	5.75
		Input	0.79	1.01	1.05	1.1	1.02	1	0.98	0.83
	64.4F(18C)	TH	12.1	12.7	12.32	11.34	10.32	9.32	8.81	6.14
		Input	0.83	1.37	1.4	1.26	1.22	1.27	1.01	0.91
	69F(20.5C)	TH	12.3	12.6	12.12	11.32	10.21	9.12	8.43	6.49
		Input	0.83	1.1	1.12	1.19	1.19	1.25	1.03	0.98
	71.6F(22C)	TH	11.1	12.4	12.01	11.21	10.01	9.02	8.21	6.01
		Input	0.85	1.15	1.16	1.21	1.23	1.31	1.05	1
09 (208-230V)	59F(15C)	TH	11.2	11.1	10.89	10.65	9.87	9.11	8.27	6.71
		Input	0.73	0.79	1.04	1.01	0.96	0.9	0.84	0.8
	64.4F(18C)	TH	11.1	10.8	10.65	10.54	9.63	8.84	8.01	5.46
		Input	0.78	0.8	1.08	1.03	0.98	0.94	0.9	0.82
	69F(20.5C)	TH	10.8	10.6	10.48	10.32	9.43	8.55	7.95	4.29
		Input	0.8	0.81	1.11	1.05	1	0.98	0.96	0.84
	71.6F(22C)	TH	10.6	10.3	10.21	10.11	9.23	8.41	7.89	4.11
		Input	0.82	0.83	1.15	1.07	1.02	1.02	0.92	0.86
12 (208-230V)	59F(15C)	TH	11.8	12.7	12.42	11.32	10.4	9.54	8.9	5.75
		Input	0.79	1.01	1.05	1.1	1.02	1	0.98	0.83
	64.4F(18C)	TH	12.1	12.7	12.32	11.34	10.32	9.32	8.81	6.14
		Input	0.83	1.37	1.4	1.26	1.22	1.27	1.01	0.91
	69F(20.5C)	TH	12.3	12.6	12.12	11.32	10.21	9.12	8.43	6.49
		Input	0.83	1.1	1.12	1.19	1.19	1.25	1.03	0.98
	71.6F(22C)	TH	11.1	12.4	12.01	11.21	10.01	9.02	8.21	6.01
		Input	0.85	1.15	1.16	1.21	1.23	1.31	1.05	1
18 (208-230V)	59F(15C)	TH	23.2	20.5	19.42	17.56	16.52	14.28	12.08	9.39
		Input	1.58	1.49	1.48	1.58	1.46	1.4	1.35	1.21
	64.4F(18C)	TH	22.4	20.1	18.66	16.89	16.05	13.94	12.06	9.16
		Input	1.62	1.55	1.55	1.61	1.52	1.45	1.4	1.29
	69F(20.5C)	TH	21.7	19.7	17.93	16.26	15.62	13.62	12.07	8.95
		Input	1.67	1.62	1.63	1.65	1.58	1.5	1.45	1.38
	71.6F(22C)	TH	21	19	17.23	15.56	14.92	12.92	11.37	8.25
		Input	1.72	1.67	1.68	1.7	1.63	1.55	1.5	1.43
24 (208-230V)	59F(15C)	TH	28.6	27.8	25.85	23.56	23.42	23.22	23.16	18.93
		Input	2	2.25	2.24	2.21	2.2	2.23	2.24	2.17
	64.4F(18C)	TH	27.6	27.6	24.52	23.54	23.4	22.52	20.45	17.45
		Input	2.24	2.45	2.35	2.35	2.32	2.23	2.21	2.16
	69F(20.5C)	TH	29.1	29.3	26.75	24.63	22.98	21.85	19.61	16.38
		Input	2.39	2.74	2.64	2.58	2.42	2.25	2.2	2.18
	71.6F(22C)	TH	26.9	27.5	24.21	23.41	22.54	21.67	19.54	16.24
		Input	2	2.25	2.24	2.21	2.2	2.23	2.24	2.17
30 (208-230V)	59F(15C)	TH	43	41.2	37.52	34.65	32.32	30.65	28.84	20.51
		Input	3.79	3.99	3.69	3.43	3.2	2.96	2.82	2.61
	64.4F(18C)	TH	39.6	39.9	36.55	33.84	30.95	28.58	26.47	19.96
		Input	3.35	4.23	3.85	3.65	3.24	3.11	3.04	2.76
	69F(20.5C)	TH	36.3	38.6	35.62	33.07	29.62	26.54	24.13	19.43
		Input	3.45	4.46	4.01	3.9	3.31	3.2	3.16	2.89
	71.6F(22C)	TH	32.9	35.2	32.22	29.67	26.22	23.14	20.73	16.03
		Input	3.68	4.69	4.24	4.13	3.54	3.43	3.39	3.12

## LEGEND

DB - Dry Bulb

WB - Wet Bulb

TH - Total Net Heating Capacity (1000 Btu/hour)

Input - Total Power (KW)

# REFRIGERATION CYCLE DIAGRAMS

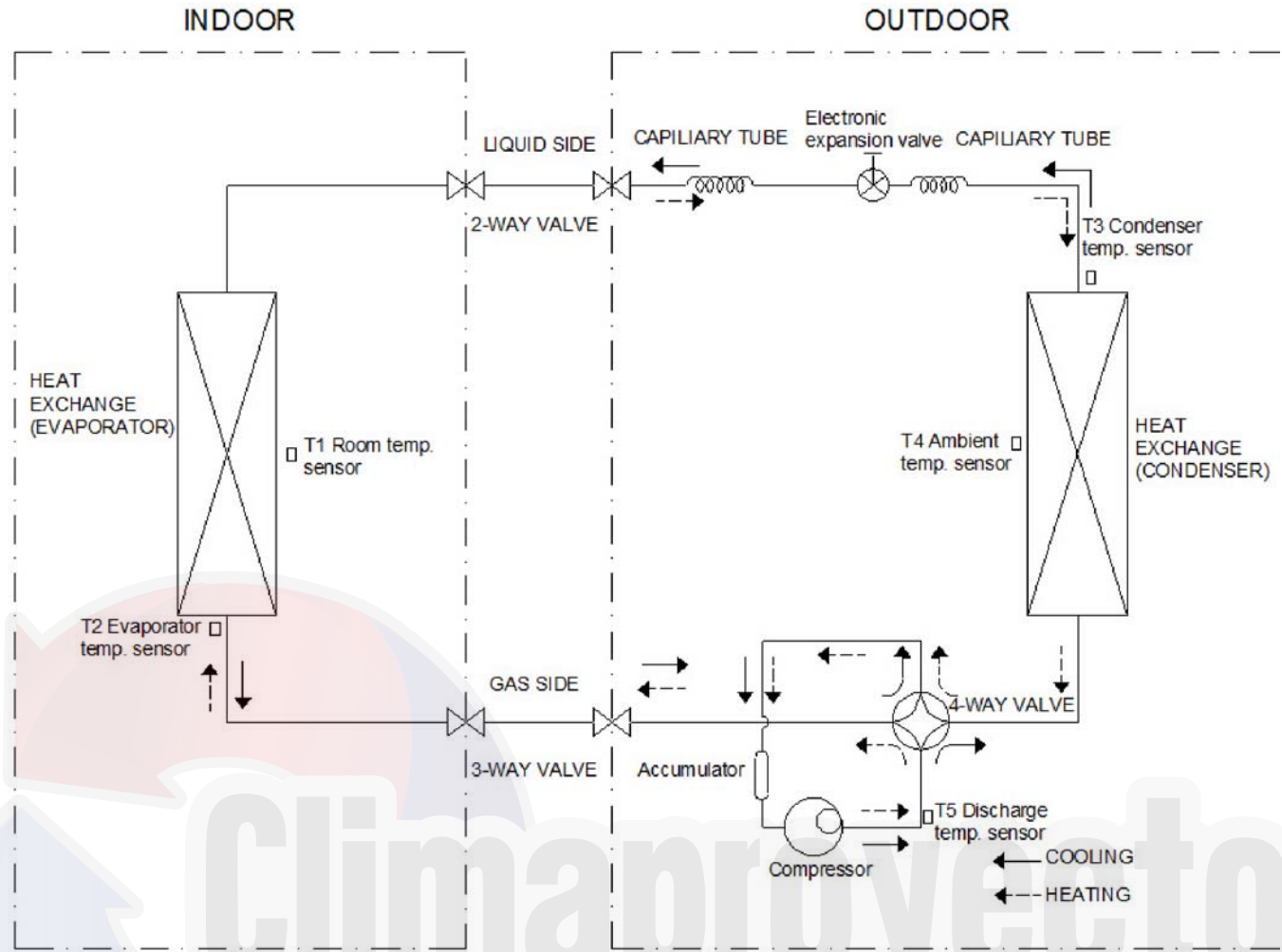

Fig. 15 – Heat Pumps

## REFRIGERANT LINES

### General refrigerant line sizing:

- 1 The outdoor units are shipped with a full charge of R410A refrigerant. All charges, line sizing, and capacities are based on runs of 25 ft (7.6 m). For runs over 25 ft (7.6 m), consult long-line section on this page for proper charge adjustments.
- 2 Minimum refrigerant line length between the indoor and outdoor units is 10 ft. (3 m).
- 3 Refrigerant lines should not be buried in the ground. If it is necessary to bury the lines, not more than 36-in (914 mm) should be buried. Provide a minimum 6-in (152 mm) vertical rise to the service valves to prevent refrigerant migration.
- 4 Both lines must be insulated. Use a minimum of 1/2-in. (12.7 mm) thick insulation. Closed-cell insulation is recommended in all long-line applications.
- 5 Special consideration should be given to isolating interconnecting tubing from the building structure. Isolate the tubing so that vibration or noise is not transmitted into the structure.

**IMPORTANT: Both refrigerant lines must be insulated separately.**

- The following maximum lengths are allowed:

System size		REFRIGERANT LINE LENGTHS ft. (m)							
		9K (115V)	12K (115V)	9K (208-230 V)	12K (208-230 V)	18K (208-230 V)	24K (208-230 V)	30K (208-230 V)	
Piping	Min. Piping Length	ft (m)	10 (3)	10 (3)	10 (3)	10 (3)	10 (3)	10 (3)	10 (3)
	Standard Piping Length	ft (m)	25 (7.5)	25 (7.5)	25 (7.5)	25 (7.5)	25 (7.5)	25 (7.5)	25 (7.5)
	Max. outdoor-indoor height difference	ft (m)	32(10)	32(10)	32(10)	32(10)	65(20)	65(20)	82(25)
	Max. Piping Length with no additional refrigerant charge	ft (m)	26(8)	26 (8)	26(8)	26(8)	26(8)	26(8)	26(8)
	Max. Piping Length	ft (m)	82(25)	82 (25)	82(25)	82(25)	98(30)	98(30)	164(50)
	Additional refrigerant charge (between Standard – Max piping length)	Oz/ft (g/m)	0.16(15)	0.16 (15)	0.16(15)	0.16(15)	0.16(15)	0.32(30)	0.32(30)
	Gas Pipe (size - connection type)	in (mm)	3/8 (9.52)	1/2 (12.7)	3/8 (9.52)	1/2 (12.7)	1/2 (12.7)	5/8 (16)	5/8 (16)
	Liquid Pipe (size - connection type)	in (mm)	1/4 in (6.35)	1/4 in (6.35)	1/4 in (6.35)	1/4 in (6.35)	1/4 in (6.35)	3/8 in (9.52)	3/8 in (9.52)
Refrigerant	Refrigerant Type		R410A	R410A	R410A	R410A	R410A	R410A	R410A
	Heat Pump Models Charge Amount	Lbs (kg)	2.76(1.25)	2.76 (1.25)	2.76(1.25)	2.76(1.25)	4.19(1.90)	5.18(2.35)	6.62(3.00)

- Above charge is for piping runs up to 25 ft. (7.6 m).
- For piping runs greater than 25 ft. (7.6 m), add refrigerant up to the allowable length as specified below.
- The outdoor unit (Sizes 09 - 18) has an electronic expansion valve to manage the refrigerant flow of the connected fan coil. Sizes 24 and 30 have capillary tube metering devices in the outdoor unit.

**Long Line Applications.:**

- No change in line sizing is required.
- Add refrigerant per table below.

**ADDITIONAL CHARGE TABLE**

Unit Size	Total Line Length ft		Additional Charge, oz/ft. ft (m)		
	Min	Max	10 - 25 (3 - 8)	>25 - 82 (8 - 25)	>82 - 164 (25 - 50)
9	10	82	None	0.16	
12		98			
18				0.32	
24					
30	164	0.32			

- Reduction in capacity due to long lines can be calculated from the chart below.

**SYSTEM EVACUATION AND CHARGING**

**⚠ CAUTION**

**UNIT DAMAGE HAZARD**

Failure to follow this caution may result in equipment damage or improper operation.

Never use the system compressor as a vacuum pump.

Refrigerant tubes and indoor coil should be evacuated using the recommended deep vacuum method of 500 microns. Always break a vacuum with dry nitrogen.

**SYSTEM VACUUM AND CHARGE**

**Using Vacuum Pump**

- Completely tighten all flare nuts and connect manifold gage charge hose to a charge port of the low side service valve. (See Fig. 16.)
- Connect charge hose to vacuum pump.
- Fully open the low side of manifold gage. (See Fig. 17)
- Start vacuum pump
- Evacuate using the triple evacuation method.
- After evacuation is complete, fully close the low side of manifold gage and stop operation of vacuum pump.
- The factory charge contained in the outdoor unit is good for up to 25 ft. (8 m) of line length. For refrigerant lines longer than 25 ft (8 m), add refrigerant as specified in the *ADDITIONAL REFRIGERANT CHARGE* table in this document.
- Disconnect charge hose from charge connection of the low side service valve.
- Fully open service valves B and A.
- Securely tighten caps of service valves.

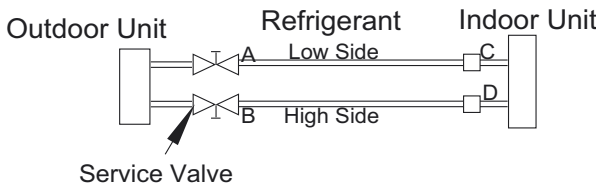

**Fig. 16 – Service Valve**

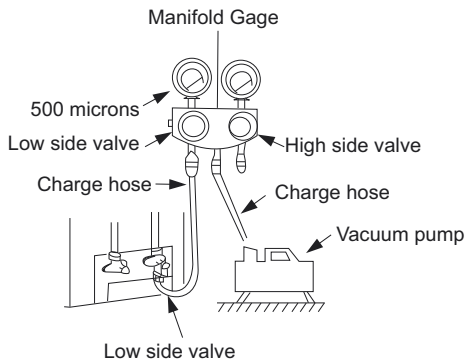

**Fig. 17 – Manifold**

**Deep Vacuum Method**

The deep vacuum method requires a vacuum pump capable of pulling a vacuum of 500 microns and a vacuum gage capable of accurately measuring this vacuum depth. The deep vacuum method is the most positive way of assuring a system is free of air and liquid water. (See Fig. 18)

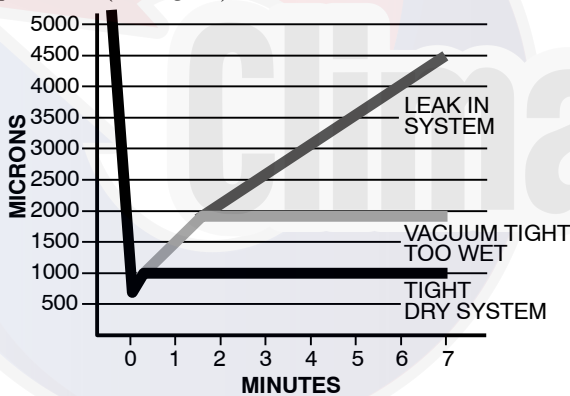
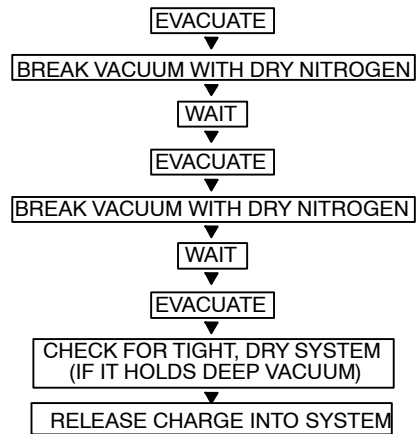

**Fig. 18 – Deep Vacuum Graph**

**Triple Evacuation Method**

The triple evacuation method should be used. Refer to Fig. 19 and proceed as follows:

- 1 Pump system down to 500 MICRONS of mercury and allow pump to continue operating for an additional 15 minutes.
- 2 Close service valves and shut off vacuum pump.
- 3 Connect a nitrogen cylinder and regulator to system and open until system pressure is 2 psig.
- 4 Close service valve and allow system to stand for 10 minutes. During this time, dry nitrogen will be able to diffuse throughout the system absorbing moisture.
- 5 Repeat this procedure as indicated in Fig. 19. System will then be free of any contaminants and water vapor.



**Fig. 19 – Triple Evacuation Method**

**Final Tubing Check**

**IMPORTANT:** Check to be certain factory tubing on both indoor and outdoor unit has not shifted during shipment. Ensure tubes are not rubbing against each other or any sheet metal. Pay close attention to feeder tubes, making sure wire ties on feeder tubes are secure and tight.

# CONTROL SYSTEM

The unit is equipped with a microprocessor control to perform two functions:

- 1 Provide safety for the system
- 2 Control the system and provide optimum levels of comfort and efficiency

The main microprocessor is located on the control board of outdoor unit. Outdoor and indoor units have thermistors used to monitor the system operation to maintain the unit within acceptable parameters and control the operating mode.

Indoor fan speed	Maximum frequency
High speed/turbo function	No limit
Silent mode	Fixed

If users switch on AC by remote controller, the compressor will run at the Fmax frequency for 7 minutes according to the outdoor ambient temp. During the 7 minutes, the frequency limitation is active. 7 minutes later, the compressor running frequency will be controlled as shown below. While the zones of A, B, C... are corresponding to different compressor running frequency.

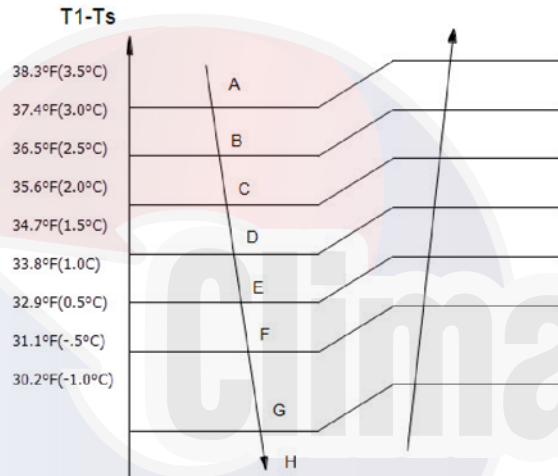

Fig. 20 – Zones

**NOTE:** When AC is in “hold” zone for 3 minutes, the compressor frequency will rise to the higher level.(frequency will increase twice at most).

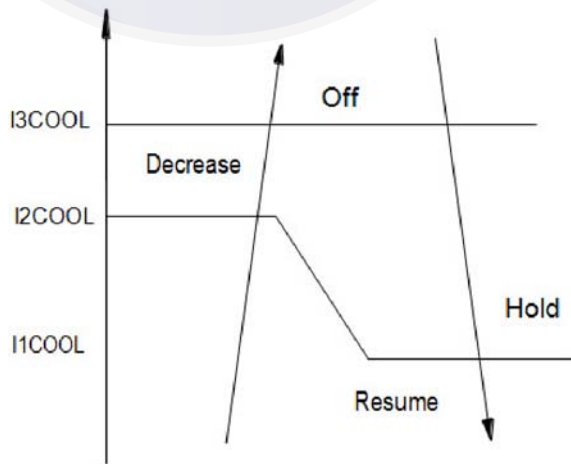

Fig. 21 – Zones

I3COOL, I2COOL, I1COOL mean different running current value.

- Off: Compressor stops.
- Decrease: Decrease the running frequency to the lower level.
- Hold: Keep the current frequency.
- Resume: No limitation for frequency.

**NOTE:** When AC is in “hold” zone for 3 minutes, the compressor frequency rises to the higher level. (Frequency increases twice at most).

When T1- Ts stays in the same temperature zone for 3 minutes, the compressor runs according to the following rules:

- 1 Increase the frequency to the higher level until F10.
- 2 Keep the current frequency.
- 3 Decrease the frequency to the lower level until F1.
- 4 Run at F1 for 1h.(if T1-Ts-ΔT>42.8°F(6°C), the compressor will stop).

Meanwhile, the compressor running frequency is limited by the current.

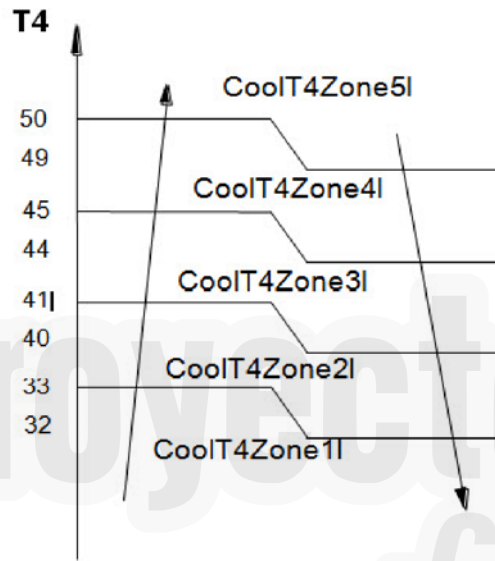

Fig. 22 – Running frequency

Setting Fan speed	T1-Ts	Actual fan speed
H	4.5	H+(H+=H+G)
	3.0	H (=H)
	1.5	H- (H=H-G)
M	4.5	M+(M+=M+Z)
	3.0	M(M=M)
	1.5	M-(M-=M-Z)
L	4.5	L+(L+=L+D)
	3.0	L(L=L)
	1.5	L-(L-=L-D)

Fig. 23 – Indoor fan running rules

In the cooling mode, indoor fan runs all the time and the speed can be selected as high, medium, low, auto and silent mode.



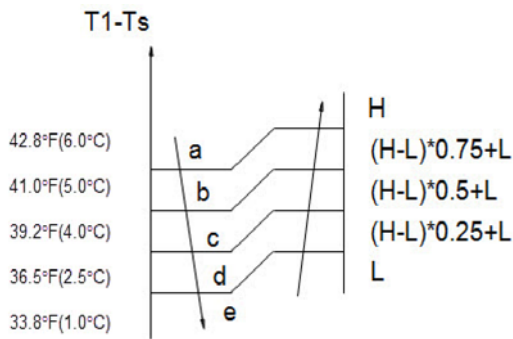

Fig. 24 – Condenser temperature protection

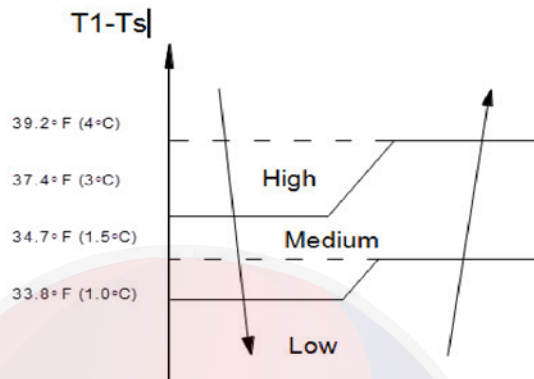

Fig. 25 – Condenser temperature protection

### Condenser temperature protection

The condenser temperature protection function acts as follows:

- If the condenser coil temperature ( $T_3$ ) is between  $131^\circ\text{F}$  and  $140^\circ\text{F}$  ( $55^\circ\text{C} < T_3 < 60^\circ\text{C}$ ), the compressor frequency will decrease to a lower level until it reaches the lowest value, F1. It then runs at this F1 frequency. Once  $T_3 < 129^\circ\text{F}$  ( $54^\circ\text{C}$ ), the compressor will continue running at the current frequency.
- Condenser temperature protection ( $131^\circ\text{F}(55^\circ\text{C}) < T_3 < 140^\circ\text{F}(60^\circ\text{C})$ ). The compressor frequency will decrease to the lower lever until to F1 and then runs at F1. If  $T_3 < 129.2^\circ\text{F}(54^\circ\text{C})$ , the compressor will keep running at the current frequency.  $T_3 < 125.6^\circ\text{F}(52^\circ\text{C})$ , the compressor will not limit the frequency and resume to the former frequency.
- When the coil temperature reaches a value lower than  $126^\circ\text{F}$  ( $52^\circ\text{C}$ ), the compressor will not limit the frequency and resumes to the required frequency.
- If  $T_3 > 140^\circ\text{F}$  ( $60^\circ\text{C}$ ) for 5 seconds, the compressor will stop and restart once the coil temperature reaches a value lower than  $126^\circ\text{F}$  ( $52^\circ\text{C}$ ).

### Evaporator Temperature Protection

The evaporator temperature protection function acts as follows:

- If the evaporator coil temperature ( $T_2$ ) is lower than  $32^\circ\text{F}$  ( $0^\circ\text{C}$ ), the compressor will stop and restarts once  $T_2 \geq 41^\circ\text{F}$  ( $5^\circ\text{C}$ ).
- $T_2 < 32^\circ\text{F}(0^\circ\text{C})$ , the compressor will stop and restart when  $T_2 \geq 41^\circ\text{F}$  ( $5^\circ\text{C}$ ).
- $32^\circ\text{F}(0^\circ\text{C}) \leq T_2 < 39.2^\circ\text{F}(4^\circ\text{C})$ , the compressor frequency will be limited and decreased to the lower level.
- $39.2^\circ\text{F}(4^\circ\text{C}) \leq T_2 \leq 44.6^\circ\text{F}(7^\circ\text{C})$ , the compressor will keep the current frequency.
- $T_2 > 44.6^\circ\text{F}(7^\circ\text{C})$ , the compressor frequency will not be limited.
- If  $32^\circ\text{F} \leq T_2 < 39^\circ\text{F}$  ( $0^\circ\text{C} \leq T_2 < 4^\circ\text{C}$ ), the compressor frequency will be limited and decreased to a lower level.
- Now, if  $39^\circ\text{F} \leq T_2 < 45^\circ\text{F}$  ( $4^\circ\text{C} \leq T_2 < 7^\circ\text{C}$ ), the compressor continue running at the current frequency.
- If  $T_2 > 45^\circ\text{F}$  ( $7^\circ\text{C}$ ), the compressor frequency will not be limited, and operation is normal.

## SEQUENCE OF OPERATION

### Interface

A wireless remote control, supplied with the unit, is the interface between the fan coil and the user. The wireless remote control has the following characteristics:

- Capable of displaying  $^\circ\text{C}$  and  $^\circ\text{F}$  with  $^\circ\text{F}$  being the default setting. To change the default setting, refer to the Owner's Manual.
- The remote control setpoint range is from  $62^\circ\text{F}$  ( $17^\circ\text{C}$ ) to  $86^\circ\text{F}$  ( $30^\circ\text{C}$ ) in increments of  $1^\circ\text{F}$  ( $1^\circ\text{C}$ ).
- The wireless remote control has an operating range of 25 ft. (7.62 m).
- The same remote control can be used to control more than one unit.
- If the remote control is lost, damaged, or the batteries are exhausted, the system can be operated by using the manual button (forced Auto) located under the front panel.

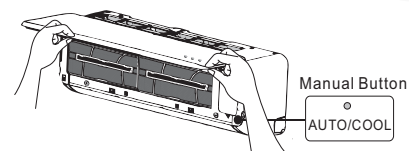

Fig. 26 – Manual Button Location on Unit

## MODES OF OPERATION

### COOLING MODE

In this mode, the system cools and dries the room air with the fan running continuously, either at a selected fan speed or Auto fan speed. The fan runs even when the compressor cycles off. This feature enhances room comfort and efficiency of the system.



**Compressor Operation in Cooling Mode:**

In cooling mode, the maximum operation frequency (Fmax) of the compressor, after it starts running, depends on the outdoor ambient temperature (T4).

Once the system starts running, the compressor will run at the Fmax frequency for 7 minutes at a specific T4. During this time, the frequency limitation is active, therefore the compressor will continue running even if the set point condition is satisfied. The compressor running frequency will then be controlled based on the difference between the room temperature and the temperature set point (T1-Ts).

**Outdoor Fan Operation in Cooling Mode:**

When in cooling mode, the outdoor fan motor cycles based on the outdoor ambient temperature as shown below:

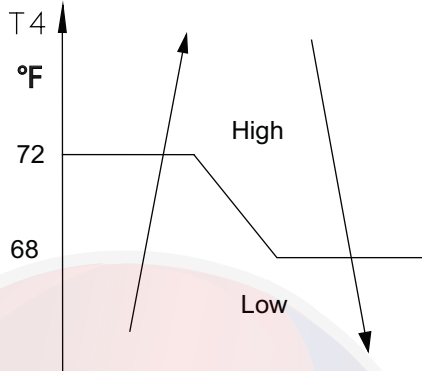

**Fig. 27 – Outdoor Fan Motor Cycles**

**Indoor Fan Operation in Cooling Mode:**

When in cooling mode, the indoor fan runs continuously either at the chosen set speed (high, medium, or low), or in Auto mode, where the speed is determined by the microprocessor based on the difference between the room temperature and the temperature set point as shown below:

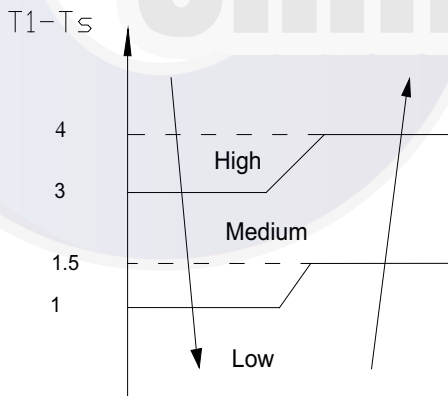

**Fig. 28 – Indoor Fan Operation**

**HEATING MODE**

In this mode, the system heats the room air with the indoor fan running at either the selected speed or on Auto. As in the cooling mode, the indoor fan will run continuously unless interrupted by the cold blow algorithm. This algorithm will not allow the fan to run if the indoor coil temperature drops below a preset value.

Defrost is controlled by the on-board microprocessor.

**Compressor Operation in Heating Mode**

In heating mode, the maximum operation frequency (Fmax) of the compressor, after it starts running, depends on the outdoor ambient temperature (T4).

Once the system starts running, the compressor will run at the Fmax frequency for 7 minutes at a specific outdoor ambient temperature (T4). During this time, the frequency limitation is active, therefore the compressor will continue running even if the set point condition is satisfied. The compressor running frequency will then be controlled based on the difference between the room temperature, the temperature set point, and a temperature difference that takes a default value of 32°F (T1-Ts-ΔT).

**Outdoor Fan Operation in Heating Mode**

When in heating mode, the outdoor fan motor cycles based on the outdoor ambient temperature as shown below:

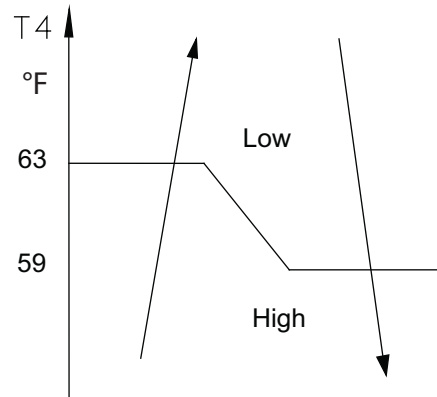

**Fig. 29 – Indoor Fan Motor Cycles**

**Indoor Fan Operation in Heating Mode**

In heating mode, the indoor fan runs depending on the evaporator coil temperature (T2).

If the set point conditions are satisfied and the compressor stops, the indoor fan will be forced to run for two minutes with breeze. During this period, the anti-cold-wind is disabled.

If the machine is running at the rated capacity test mode, the indoor fan will run at the rated speed and the anti-cold-wind function is disabled.

**Auto Mode in Heating Mode**

In heating mode, when the fan speed is set to Auto, the fan will run at a speed determined by the microprocessor based on the difference between the room temperature and the temperature set point as shown below:

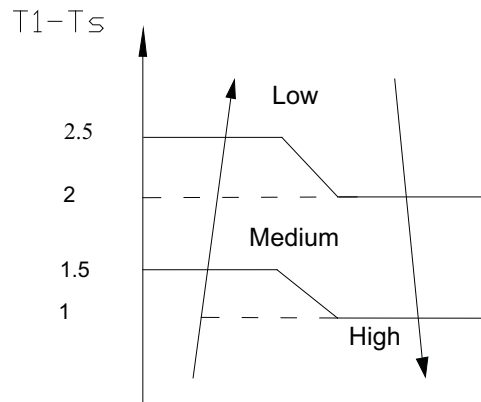

**Fig. 30 – Auto Mode**

**Defrost**

Defrost on heat pump units is controlled by the microprocessor and is initiated if either of the following conditions occur:

- 1 If the outdoor temperature,  $T4 > 32^{\circ}\text{F}$  ( $0^{\circ}\text{C}$ ):
  - The outdoor coil temperature (T3) has been lower than  $37^{\circ}\text{F}$  ( $3^{\circ}\text{C}$ ) for about 40 minutes. During that time, the coil temperature is lower than TCDI for more than 3 minutes.
- 2 If the outdoor temperature,  $T4 < 32^{\circ}\text{F}$  ( $0^{\circ}\text{C}$ ):
  - If the conditions described above are met, the program judges if the evaporator coil temperature (T2) has decreased more than  $41^{\circ}\text{F}$  ( $5^{\circ}\text{C}$ ). When the evaporator coil temperature has decreased more than  $41^{\circ}\text{F}$  ( $5^{\circ}\text{C}$ ), the defrost mode starts.
- 3 At any value of outdoor ambient temperature (T4):
  - If the machine runs with a condenser coil temperature lower than  $37^{\circ}\text{F}$  ( $3^{\circ}\text{C}$ ) for more than 120 minutes and the outdoor coil temperature (T3) has been lower than (TCDI+ $39^{\circ}\text{F}$ ) for more than 3 minutes, the machine enters the defrost mode.

Where: TCDI =  $-7^{\circ}\text{C}$  =  $19.4^{\circ}\text{F}$

**Indoor fan running rules**

Indoor fan speed can be set as high, medium, low, silent mode or auto grade. During all the fan speeds, the anti-cold-wind function is preferential. If the compressor stops caused by the room temperature rising, the indoor fan will run at super breeze. When the compressor is running, the indoor fan is controlled.

**Outdoor fan running rules**

In cooling mode the outdoor fan runs according to Fig 31.

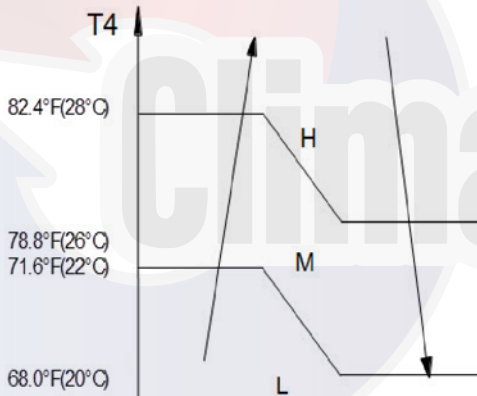

Fig. 31 – Outdoor fan running rules

**Condition of defrosting:**

----  $T4 < 32^{\circ}\text{F}$  ( $0^{\circ}\text{C}$ ),

When the unit is running and the following two items are satisfied, the unit starts defrosting. The units run with  $T3 < 37.4^{\circ}\text{F}$  ( $3^{\circ}\text{C}$ ) for 40 minutes and T3 keeps lower than TCDI for more than 3 minutes. The units run with  $T3 < 37.4^{\circ}\text{F}$  ( $3^{\circ}\text{C}$ ) for 80 minutes and T3 keeps lower than TCDI  $35.6^{\circ}\text{F}$  ( $2^{\circ}\text{C}$ ) for more than 3 minutes. ----  $T4 < 32^{\circ}\text{F}$  ( $0^{\circ}\text{C}$ ).

If the 1st condition and 2nd condition items are satisfied, then the program judges if T2 has decreased more than  $41^{\circ}\text{F}$  ( $2^{\circ}\text{C}$ ). When T2 has decreased more than  $41^{\circ}\text{F}$  ( $2^{\circ}\text{C}$ ) enter the defrosting mode.

No matter what value T4 is, if the machine runs with  $T3 < 37.4^{\circ}\text{F}$  ( $3^{\circ}\text{C}$ ) for more than 120 minutes and T3 keeps lower than TCDI+ $39.2^{\circ}\text{F}$  ( $4^{\circ}\text{C}$ ) for more than 3 minutes, the machine will enter defrosting mode no matter if T2 drops more than  $41^{\circ}\text{F}$  ( $5^{\circ}\text{C}$ ) or not.

**Condition of ending defrosting:**

If any one of the following items is satisfied, the defrosting will finish and the machine will turn to normal heating mode.

- T3 rises to be higher than TCDE  $1^{\circ}\text{F}$
- T3 keeps to be higher than TCDE  $4^{\circ}\text{F}$  for 80 seconds.
- The machine has run for 10 minutes in defrosting mode.

**Defrosting action:**

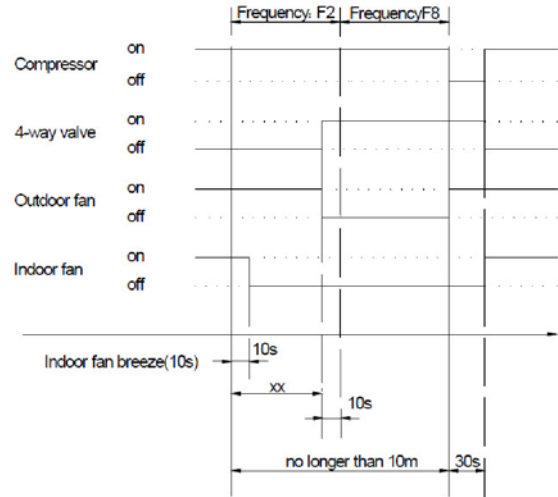

Fig. 32 – 9k,12k, 18k, 24k, 30k models

XX=60s

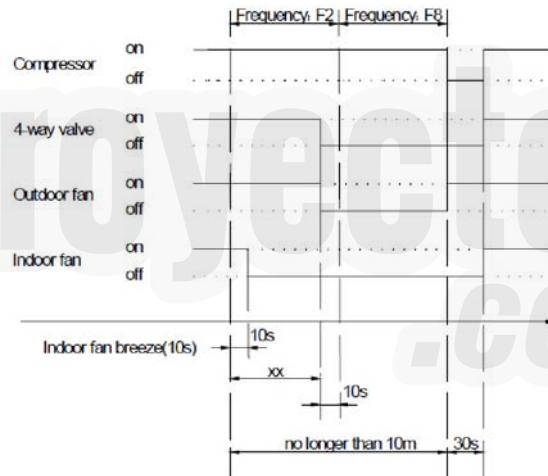

Fig. 33 – 9k,12k, 18k, 24k, 30k models

**Evaporator coil temperature protection**

----  $T2 > \text{TEH} 2^{\circ}\text{F}$ , the compressor running frequency decreases to the lower level and runs for 20s. When the frequency decreases to F2 and the T2 is still over TEH  $2^{\circ}\text{F}$  for 3 minutes, the compressor stops.

## AUTO MODE

In the Auto mode, the temperature can be set to values between 62~86°F (17~30°C). In this mode, the machine will choose cooling, heating or fan-only mode according to  $\Delta T$ .

**NOTE:**  $\Delta T = T1 - Ts$ , where T1 represents the indoor room temperature and Ts represents the set temperature.

$\Delta T = T1 - Ts$	Running mode
$\Delta T > 2^\circ F$	Cooling
$-1 < \Delta T \leq 2^\circ F$	Fan-only
$\Delta T \leq -2^\circ F$	Heating

Indoor fan will run at an automatic fan speed for each running mode. The louver will also operate depending in relevant mode taking place. If the machine switches mode between heating and cooling, the compressor will stop for 15 minutes and then choose a mode according to  $\Delta T$ .

If a new set temperature is commanded, the system will choose a running mode according to  $\Delta T$ .

## FORCED OPERATION FUNCTION

When the machine is off, pressing the manual button will carry the machine to forced auto mode. Pressing the button once again, within 5 seconds, the machine will turn into forced cooling mode.

In forced auto, forced cooling or any other operation mode, pressing the manual button will turn off the machine.

When in this mode, all general protections are available.

### Forced cooling mode:

The compressor runs at F2 frequency and indoor fan runs as breeze.

After running for 30 minutes, the machine will turn to auto mode with a 75°F (24°C) set temperature.

### Forced auto mode:

The action of forced auto mode is the same as normal auto mode with a 75°F (24°C) set temperature.

## TIMER FUNCTION

Timing range is 24 hours.

The timer function will not change the system's current operation mode.

The setting time is relative time.

### Timer on

The machine will turn on automatically when reaching the set time.

### Timer off

The machine will turn off automatically when reaching the setting time.

### Timer on/off

The machine will turn on automatically when reaching the set "on" time, and then turn off automatically when reaching the set "off" time.

The timer function will not change the AC current operation mode. Suppose AC is off now, it will not start up first after setting the "timer off" function. And when reaching the setting time, the timer LED will turn off and the AC running mode will not change.

## SLEEP MODE FUNCTION

Operation time in sleep mode is 7 hours. After 7 hours the system turns off.

Operation process in sleep mode is as follow:

### **SLEEP MODE - COOLING**

When in cooling mode, the set temperature rises 1.8°F (1°C) (up to a maximum 86°F (30°C)) every one hour. Two hours later the set temperature stops rising and indoor fan is fixed at low speed.

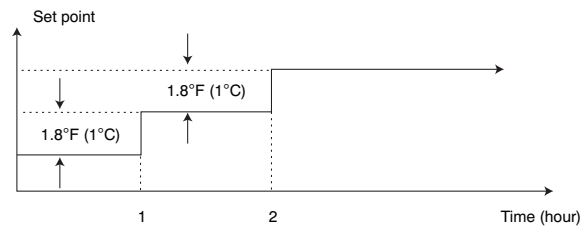

**Fig. 34 – Sleep Mode - Heating**

When in heating mode, the set temperature decreases 1.8°F (1°C) (down to a minimum 62°F (17°C)) every one hour. Two hours later the set temperature stops rising and indoor fan is fixed at low speed.

**NOTE:** Anti-cold wind function has the priority.

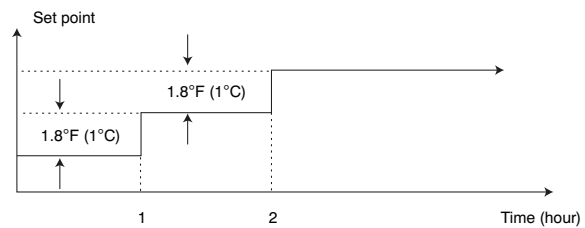

Timer setting is available.

When the user uses timer off function in sleep mode (or sleep function in timer off mode), if the timing is less than 7 hours, sleep function will be cancelled when reaching the setting time. If the timing is more than 7 hours, the machine will not stop until it reaches the set time in sleep mode.

## AUTO-RESTART FUNCTION

The indoor unit is equipped with auto-restart function, which is carried out through an auto-restart module. In case of a sudden power failure, the module memorizes the setting conditions present previous to the power failure. The unit will automatically resume to the previous operation settings (not including swing function) 3 minutes after the power returns.

If the memorization condition is forced cooling mode, the unit will run in cooling mode for 30 minutes and turn to auto mode at a 75°F (24°C) set temp.

If unit is off before power off and unit is required to start up now, the compressor will have 1 minute delay when power on. Other conditions, the compressor will have 3 minutes delay when restarts.

If the equipment was off before the power went off, and it is required to start up after this power failure, the compressor will have a 1 minute delay when powering on. In other conditions, the compressor will have a 3 minutes delay at re-start.

### **Follow me**

- 1 If the indoor PCB receives the signal which results from pressing the FOLLOW ME button on remote controller, the buzzer will emit a sound and this indicates the follow me function is initiated. But when the indoor PCB receives signal which sent from remote controller every 3 minutes, the buzzer will not respond. When the unit is running with follow me function, the PCB will control the unit according to the temperature from follow me signal, and the temperature collection function of room temperature sensor will be shielded, but the error detective function of room temperature sensor will be still valid.
- 2 When the follow me function is available, the PCB will control the unit according to the room temperature from the remote controller and the setting temperature.
- 3 The PCB will take action to the mode change information from remote controller signal, but it will not be affected by the setting temperature.
- 4 When the unit is running with follow me function, if the PCB does not receive any signal from remote controller for 7 minutes or pressing FOLLOW ME button again, the follow me function will be turned off automatically, and the temperature will control the unit according to the room temperature detected from its own room temperature sensor and setting temperature.

### **Self Clean**

For heat pump models which are provided with this function, after running in cooling or drying mode, if the user press "Self Clean" button on remote controller, indoor unit runs in fan only mode for 13 minutes, then low heat operation and finally in fan only again. This function can keep the inside of indoor unit dry and prevent breeding of mold.

### **Refrigerant Leakage Detection**

With this new technology, the display area will show "EC" when the outdoor unit detects refrigerant leakage. This feature is only available in the cooling mode for 1 to 1 systems.

T2: indoor coil temp. Tcool: sample temp. of T2 when the compressor starts. During the first 5 minutes after compressor's start, if the situation that  $T2 < Tcool - 3.6^{\circ} F$  does not last for 4 seconds continuously, the system will record suspected refrigerant leakage once, and the compressor will stop.

If the above case happened three times continuously, the system will judge refrigerant leakage. Indoor unit will indicate error code "EC" and the unit will turn off automatically.

Refrigerant leakage count will reset under following situation:

During the first 5 minutes after compressor's start, the situation that  $T2 < Tcool - 3.6^{\circ} F$  lasts for 4 seconds continuously.

Evaporator anti-freeze protection in cooling mode.  
Non-cooling mode.

### **Louver Position Memory Function**

When starting the unit again after shutting down, its louver will restore to the angle originally set by the user, but the precondition is that the angle must be within the allowable range, if it exceeds, it will memorize the maximum angle of the louver. During operation, if the power fails the louver will restore to the default angle.

### **46°F (8°C) Heating (heating setback)**

In heating operation, the preset temperature of the air conditioner can be as low as 46°F, which keeps the room temperature steady at 46°F and prevents household pipes from freezing when the house is unoccupied for a long time in severe cold weather.

### **Silence operation**

Press the "silence" button on remote controller to initiate SILENCE function. When the Silence function is activated, the compressor running frequency will keep lower than F2 and the indoor unit will supply faint breeze, which will reduce the noise to the lowest level and create a quiet and comfortable room for you.

## **TROUBLESHOOTING**

This section provides the required flow charts to troubleshoot problems that may arise.

**NOTE: Information required in the diagnoses can be found either on the wiring diagrams or in the appendix.**

### **Required Tools:**

The following tools are needed when diagnosing the units:

- Digital multimeter
- Screw drivers (Phillips and straight head)
- Needle-nose pliers
- Refrigeration gauges

### **Recommended Steps**

- 1 Refer to the diagnostic hierarchy charts below and determine the problem at hand.
- 2 Go to the chart listed in the diagnostic hierarchy and follow the steps in the chart for the selected problem.

For the ease of service, the systems are equipped with diagnostic code display LED's on both the indoor and outdoor units. The outdoor diagnostic display is on the outdoor unit board and is limited to very few errors. The indoor diagnostic display is a combination of flashing LED's on the display panel on the front of the unit. If possible always check the diagnostic codes displayed on the indoor unit first.

The diagnostic codes for the indoor and outdoor units are listed in the appendix.

Problems may occur that are not covered by a diagnostic code, but are covered by the diagnostic flow charts. These problems will be typical air conditioning mechanical or electrical issues that can be corrected using standard air conditioning repair techniques.

For problems requiring measurements at the control boards, note the following:

- 1 Always disconnect the main power.
- 2 When possible check the outdoor board first.
- 3 Start by removing the outdoor unit top cover.
- 4 Reconnect the main power
- 5 Probe the outdoor board inputs and outputs with a digital multi-meter referring to the wiring diagrams.
- 6 Connect the red probe to hot signal and the black probe to the ground or negative.
- 7 Note that some of the DC voltage signals are pulsating voltages for signal. this pulse should be rapidly moving at all times when there is a signal present.
- 8 If it is necessary to check the indoor unit board you must start by disconnecting the main power.
- 9 Next remove the front cover of the unit and then control box cover.
- 10 Carefully remove the indoor board from the control box, place it face up on a plastic surface (not metal).
- 11 Reconnect the main power and repeat steps 5,6, and 7.
- 12 Disconnect main power before reinstalling board to avoid shock hazard and board damage.

# INDOOR UNIT DIAGNOSTIC GUIDES

Operation lamp	Timer lamp	Display	LED STATUS
★ 1 time	X	E0	Indoor unit EEPROM parameter error
★ 2 times	X	E1	Indoor / outdoor units communication error
★ 3 times	X	E2	Zero-crossing signal detection error
★ 4 times	X	E3	Indoor fan speed has been out of control
★ 5 times	X	E4	Indoor room temperature sensor T1 open circuit or short circuit
★ 6 times	X	E5	Evaporator coil temperature sensor T2 open circuit or short circuit
★ 7 times	X	EC	Refrigerant leakage detection
★ 2 times	O	F1	Outdoor ambient temperature sensor T4 open circuit or short circuit
★ 3 times	O	F2	Condenser coil temperature sensor T3 open circuit or short circuit
★ 4 times	O	F3	Compressor discharge temperature sensor T5 open circuit or short circuit
★ 5 times	O	F4	Outdoor unit EEPROM parameter error
★ 6 times	O	F5	Outdoor fan speed has been out of control
★ 1 times	★	P0	IPM malfunction or IGBT over-strong current protection
★ 2 times	★	P1	Over voltage or over low voltage protection
★ 3 times	★	P2	High temperature protection of compressor top diagnosis and solution (only for 9k, 12k models)
★ 5 times	★	P4	Inverter compressor drive error

O(light) X(off) ★(flash)

## DIAGNOSIS AND SOLUTION

### EEPROM parameter error - diagnosis and solution (E0/F4)

<b>Error Code</b>	E0/F4
<b>Malfunction decision conditions</b>	Indoor or outdoor PCB main chip does not receive feedback from EEPROM chip.
<b>Supposed Causes</b>	<ul style="list-style-type: none"> <li>• Installation mistake</li> <li>• PCB faulty</li> </ul>

Trouble shooting:

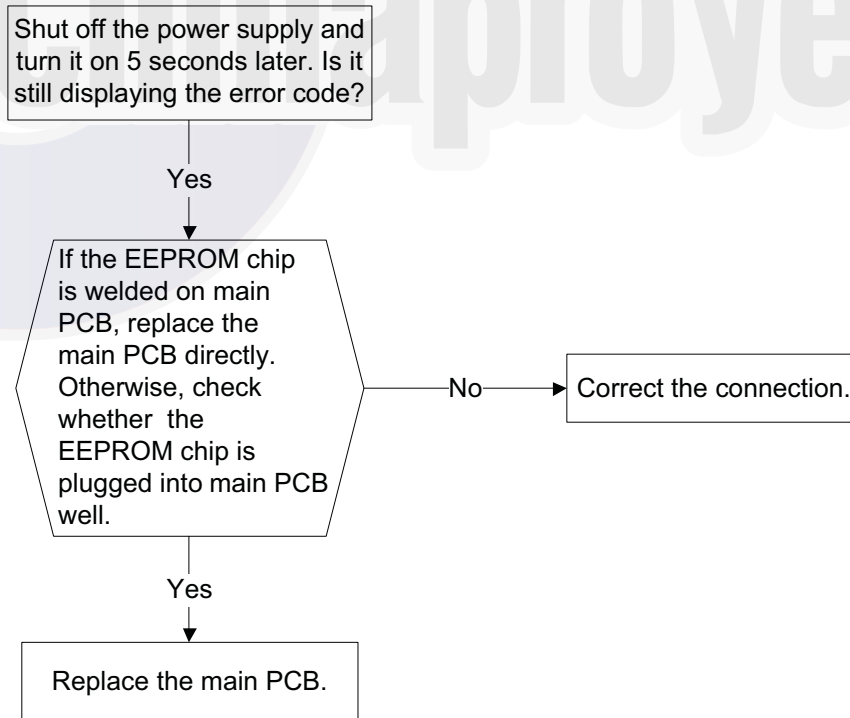

EEPROM: a read-only memory whose contents can be erased and reprogrammed using a pulsed voltage.



## Indoor / outdoor unit's communication error - diagnosis and solution (E1)

<b>Error Code</b>	E1
<b>Malfunction decision conditions</b>	Indoor unit does not receive feedback from outdoor unit in 110 seconds, and this condition occurs four times continuously.
<b>Supposed Causes</b>	Indoor and outdoor unit communications fault

### Troubleshooting:

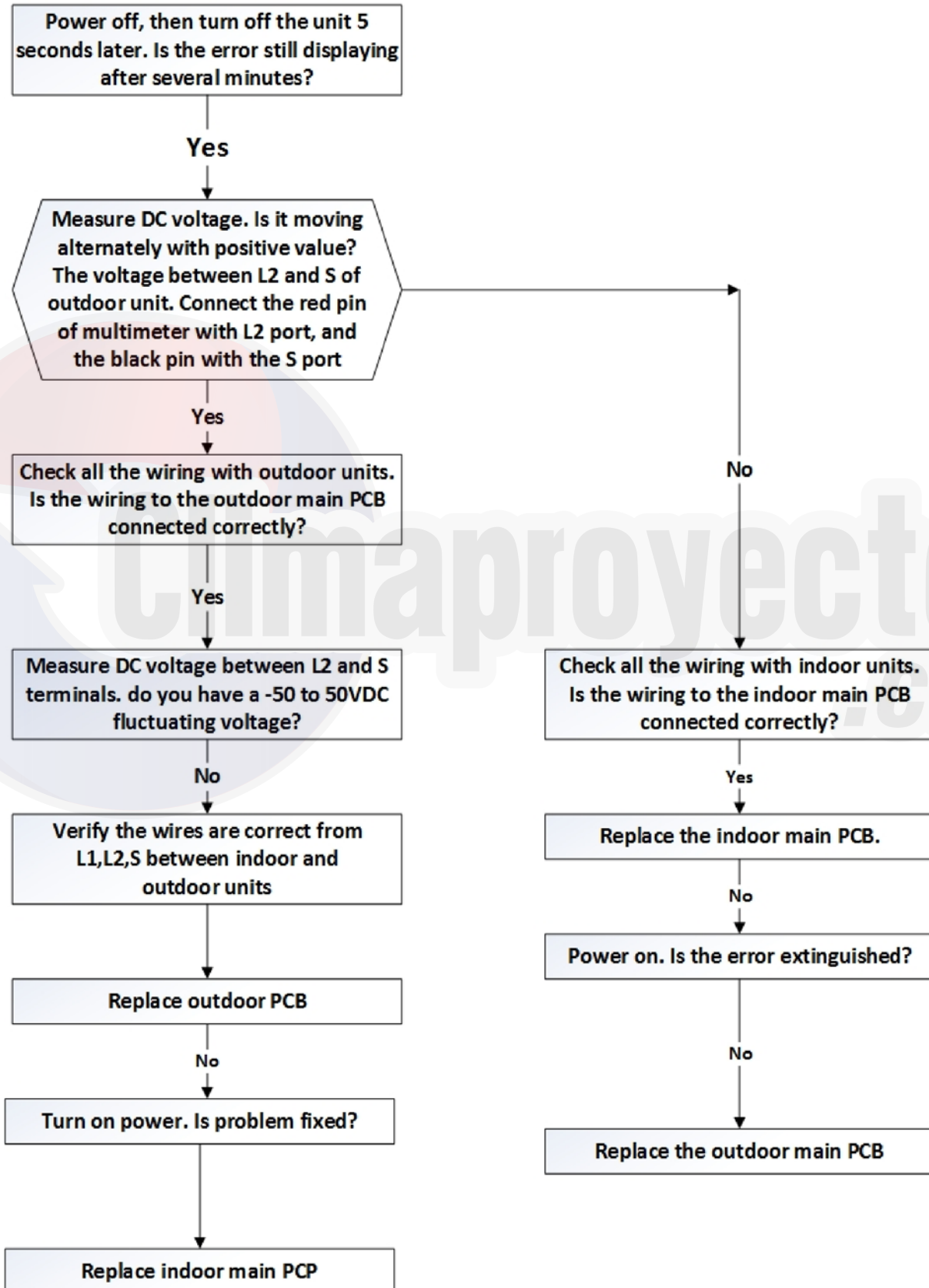

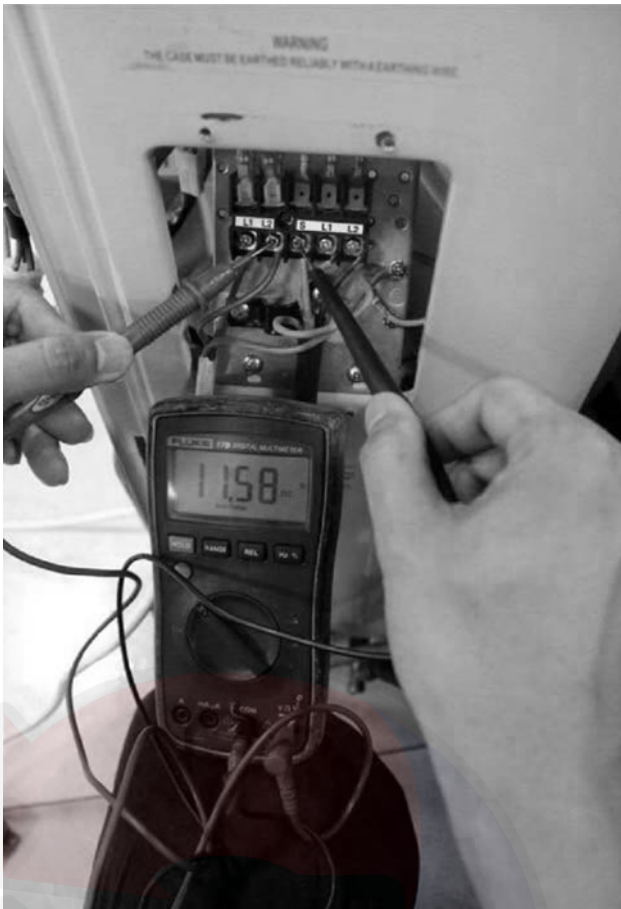

Fig. 35 – DC voltage test

### Remark

Use a multimeter to test the DC voltage between the L2 port and S ports of the outdoor unit. (Fig. 35) The red pin of multimeter connects with the L2 port while the black pin is for the S port.

When the AC is running normally, the voltage will move alternatively between -50V to 50V.

If the outdoor unit has a malfunction, the voltage will move alternatively with a positive value.

If the indoor unit has a malfunction, the voltage will be a certain value. Example: 10-13VDC small fluctuating amounts indicates indoor unit malfunction.



Fig. 36 – Reactor resistance test

### Remark

Use a multimeter to test the resistance of the reactor which does not connect with the capacitor (Fig. 36).

The normal values should be around zero ohm.

Otherwise, the reactor must have a malfunction and must be replaced.



## Zero crossing detection error diagnosis and solution (E2)

<b>Error Code</b>	<b>E2</b>
<b>Malfunction decision conditions</b>	When PCB does not receive zero crossing signal feedback for 4 minutes or the zero crossing signal interval is abnormal
<b>Supposed Causes</b>	<ul style="list-style-type: none"><li>• Connection mistake</li><li>• PCB faulty</li></ul>

### Troubleshooting:

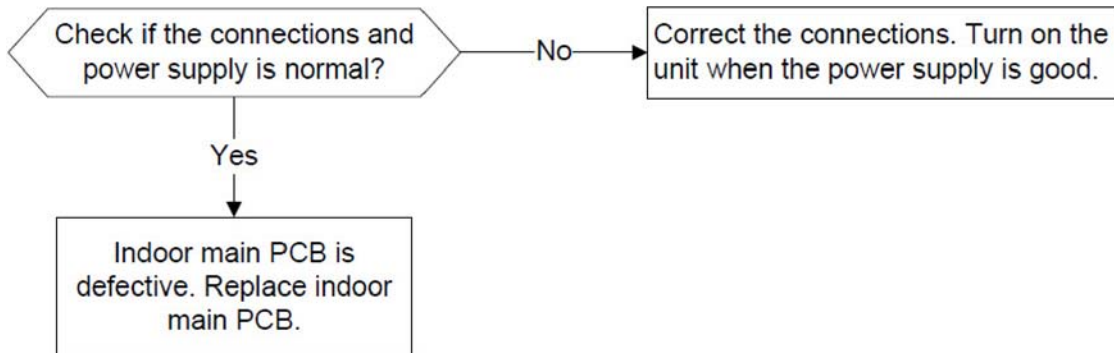

### Fan speed has been out of control diagnosis and solution (E3)

<b>Error Code</b>	<b>E3</b>
<b>Malfunction decision conditions</b>	When the indoor fan speed is too slow (300 RPM) for a certain time, the unit will stop and the LED will display the failure.
<b>Supposed Causes</b>	<ul style="list-style-type: none"> <li>• Wiring mistake</li> <li>• Fan assembly faulty</li> <li>• Fan motor faulty</li> <li>• PCB faulty</li> </ul>

#### Troubleshooting:

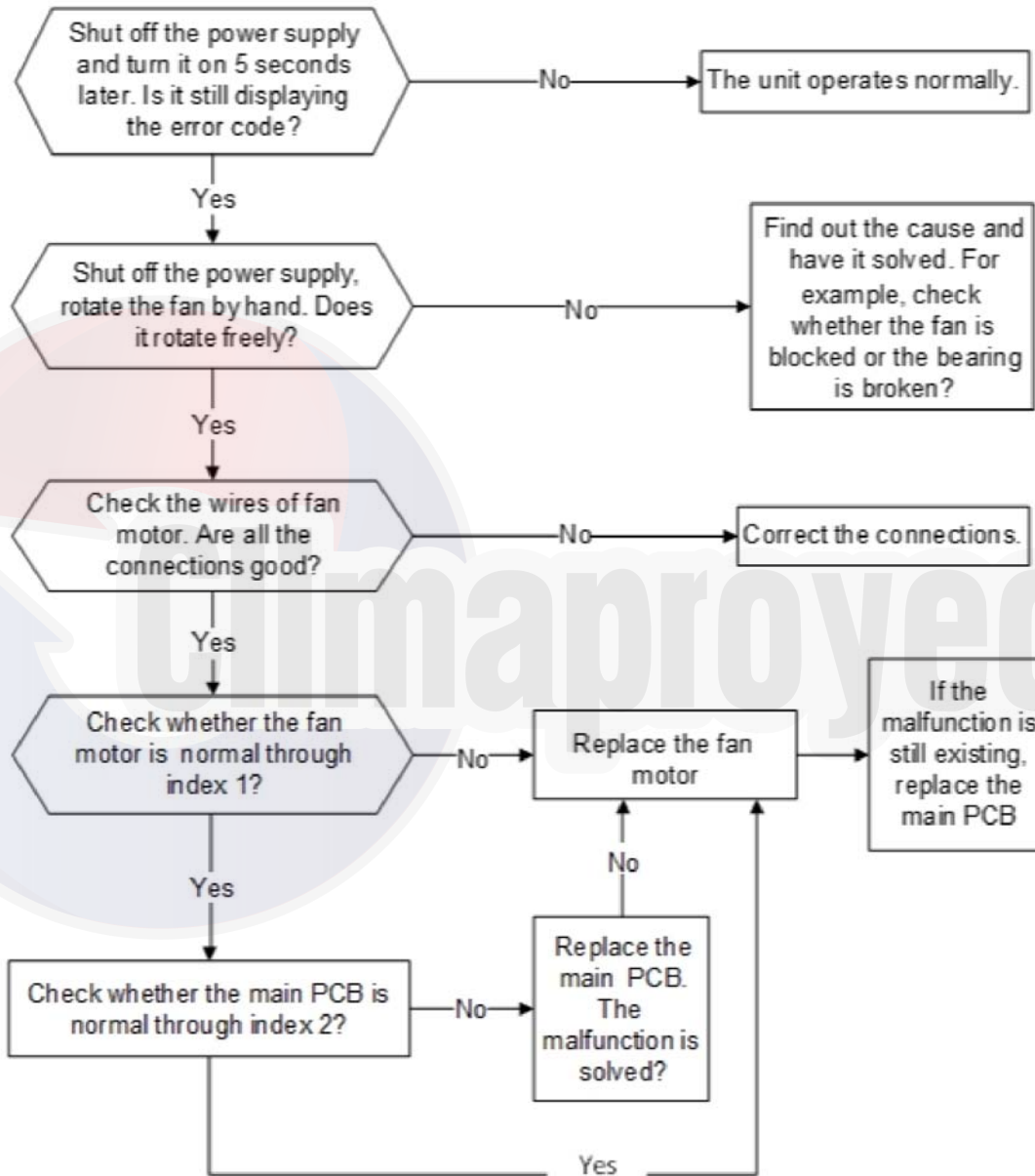

**Index 1:**

Indoor or outdoor DC fan motor (control chip is in fan motor) Measure the resistance value of each winding by using the tester. If any resistance value is zero, the fan motor must have problems and needs to be replaced.

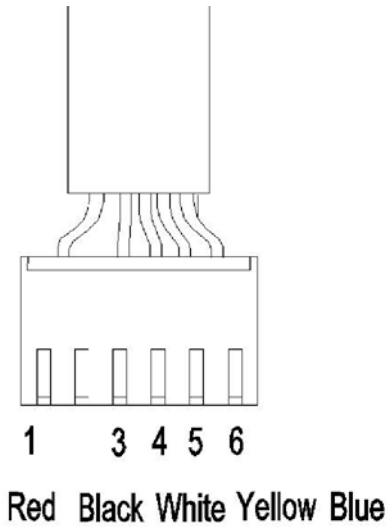

**Fig. 37 – Fan motor**

**Index 2:**

- 1 Indoor or Outdoor DC Fan Motor (control chip is in the fan motor). Power on and when the unit is in standby, measure the voltage of pin- 1 - pin3, pin4- pin3 in the fan motor connector. If the value of the voltage is not in the range showing in the table below, the PCB has an issue and needs to be replaced.

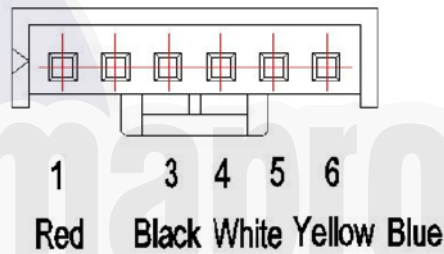
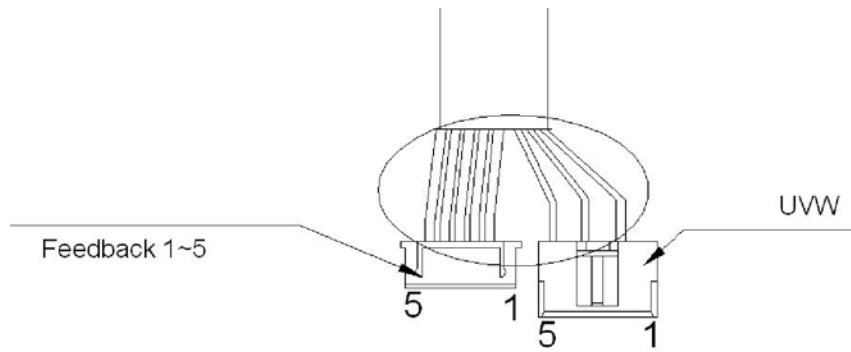

**Fig. 38 – Control chip**

**DC motor voltage input and output**

No.	Color	Signal	Voltage
1	Red	Vs/Vm	280V- 380V
2	---	---	---
3	Black	GND	0V
4	White	Vcc	14- 14.5V
5	Yellow	Vsp	0~5.6V
6	Blue	FG	14- 17.5V

2 Outdoor DC Fan Motor (control chip is in the outdoor PCB)



**Fig. 39 – Outdoor DC Fan Motor**

<b>No.</b>	<b>1</b>	<b>2</b>	<b>3</b>	<b>4</b>	<b>5</b>
Color	Orange	Grey	White	Pink	Black
Signal	Hu	Hv	Hw	Vcc	GND

<b>Color</b>	<b>Red</b>	<b>Blue</b>	<b>Yellow</b>
Signal	W	V	U

- 1 Release the UVW connector. Measure the resistance of U- V, U- W, V- W. If the resistance is not equal to each other, the fan motor has an issue and needs to be replaced. Otherwise, proceed to step 2.
- 2 Power on and when the unit is in standby, measure the voltage of pin 4-5 in the feedback signal connector. If the value is not 5V, change the PCB. Otherwise proceed to step 3.
- 3 Rotate the fan by hand, measure the voltage of pin 1-5, pin 2-5, and pin 3-5 in the feedback signal connector. If any voltage is not positive voltage fluctuation, the fan motor has an issue and must be replaced.



### Open circuit or short circuit of temperature sensor diagnosis and solution (E5)

Error Code	E5
Malfunction decision conditions	If the sampling voltage is lower than 0.06V or higher than 4.94V, the LED will display the failure.
Supposed Causes	<ul style="list-style-type: none"><li>• Wiring mistake</li><li>• Sensor faulty</li></ul>

Troubleshooting:

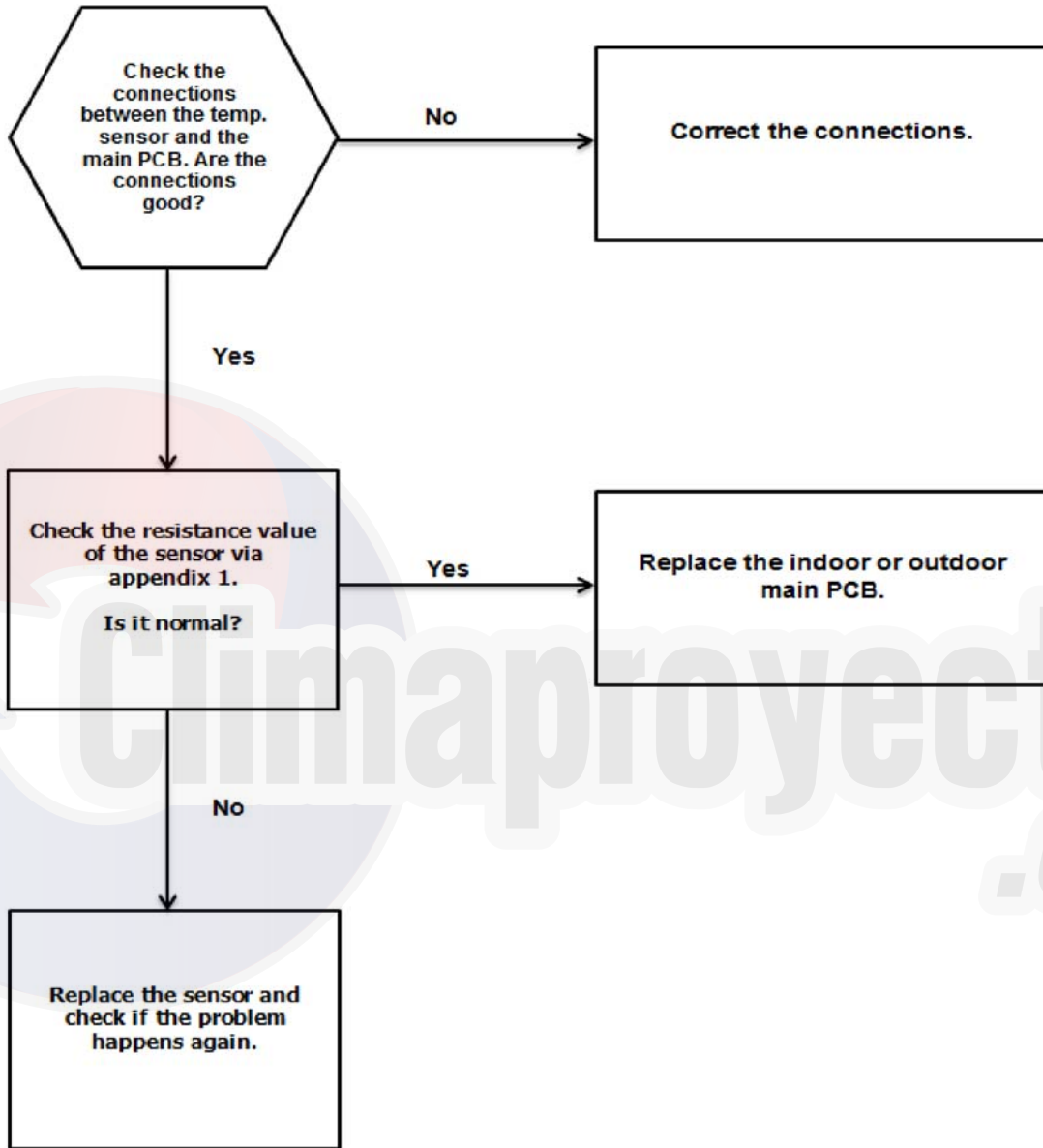
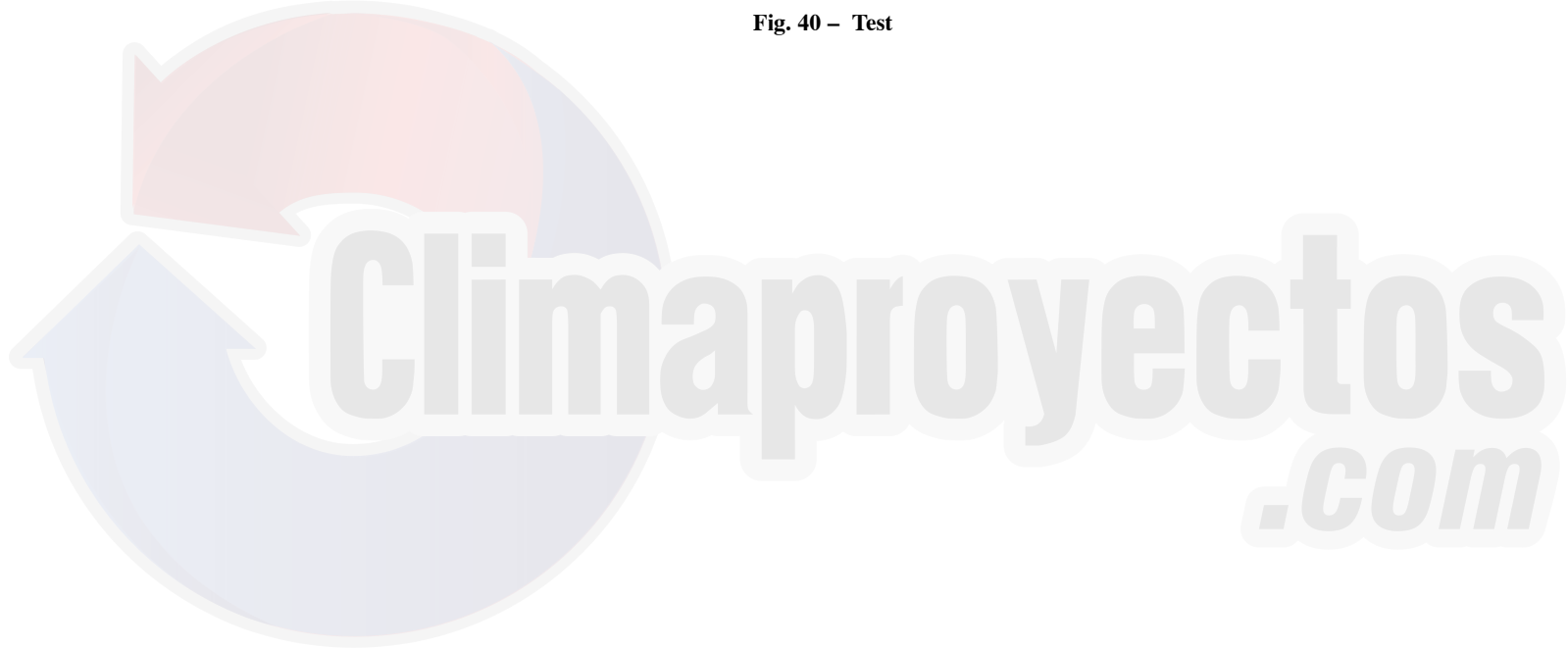



Fig. 40 – Test



**Refrigerant Leakage Detection Diagnosis and Solution (EC)**

Error Code	EC
Malfunction decision conditions	Define the evaporator coil temp.T2 of the compressor just starts running as Tcool. In the beginning 5 minutes after the compressor starts up, if $T2 < T_{cool} - 35.6^{\circ}\text{F} (T_{cool} - 2^{\circ}\text{C})$ does not keep continuous 4 seconds and this situation happens 3 times, the display area will show "EC" and AC will turn off.
Supposed caused	<ul style="list-style-type: none"> <li>• T2 sensor faulty</li> <li>• Indoor PCB faulty</li> <li>• System problems, such as leakage or blocking</li> </ul>

**Troubleshooting**

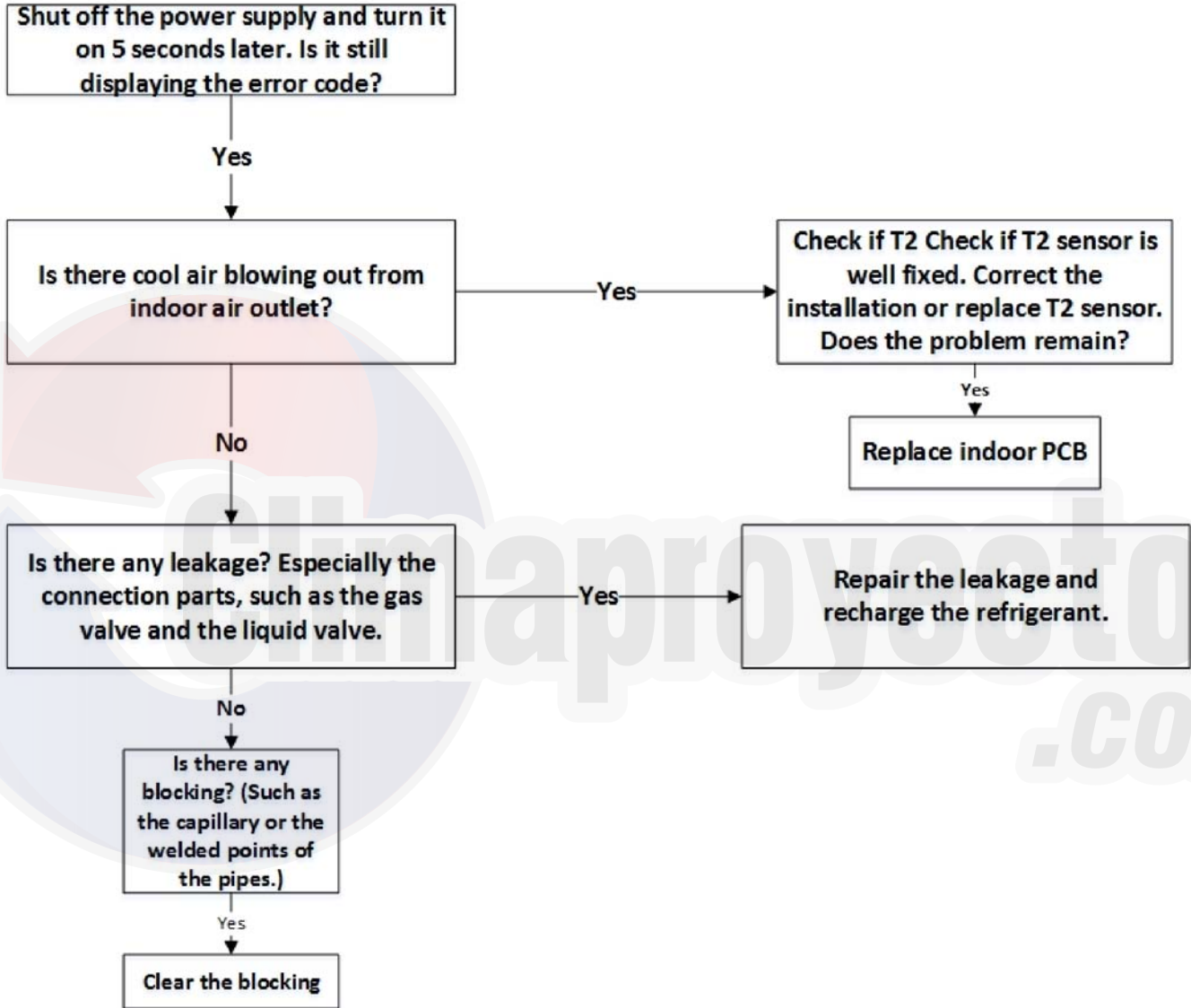



IPM malfunction or IGBT over-strong current protection diagnosis and solution (PO)

Error Code	PO
Malfunction decision conditions	When the voltage signal that IPM sends to the compressor drive chip is abnormal, the LED display will show "PO" and the AC will turn off.
Supposed causes	<ul style="list-style-type: none"> <li>• Wiring mistake</li> <li>• IPM malfunction</li> <li>• Outdoor fan assembly faulty</li> <li>• Compressor malfunction</li> <li>• Outdoor PCB faulty</li> </ul>

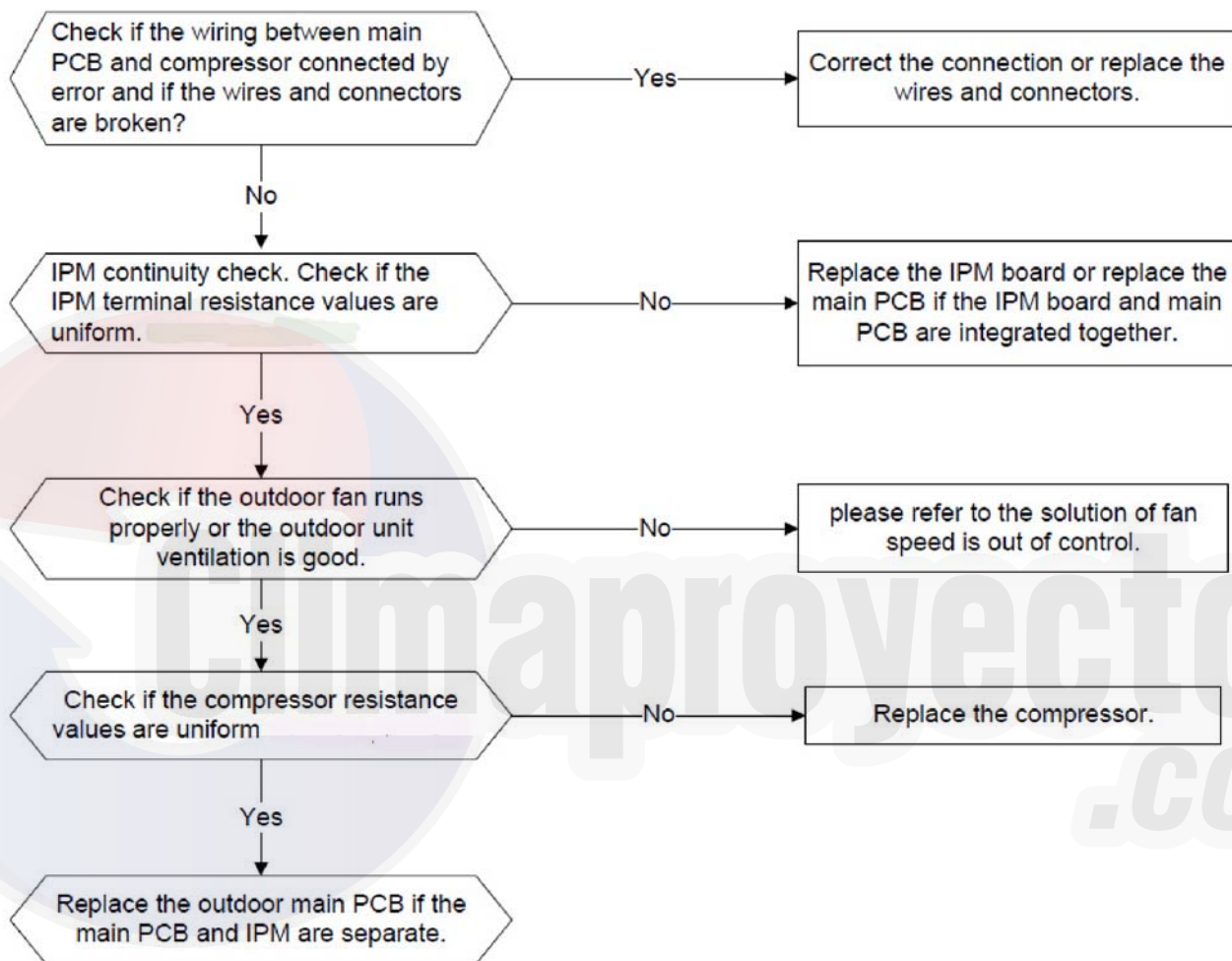

**NOTE:** In figures 41-46 the following is observed:

- U,V,W references compressor connection point
- P references input voltage
- N references output voltage

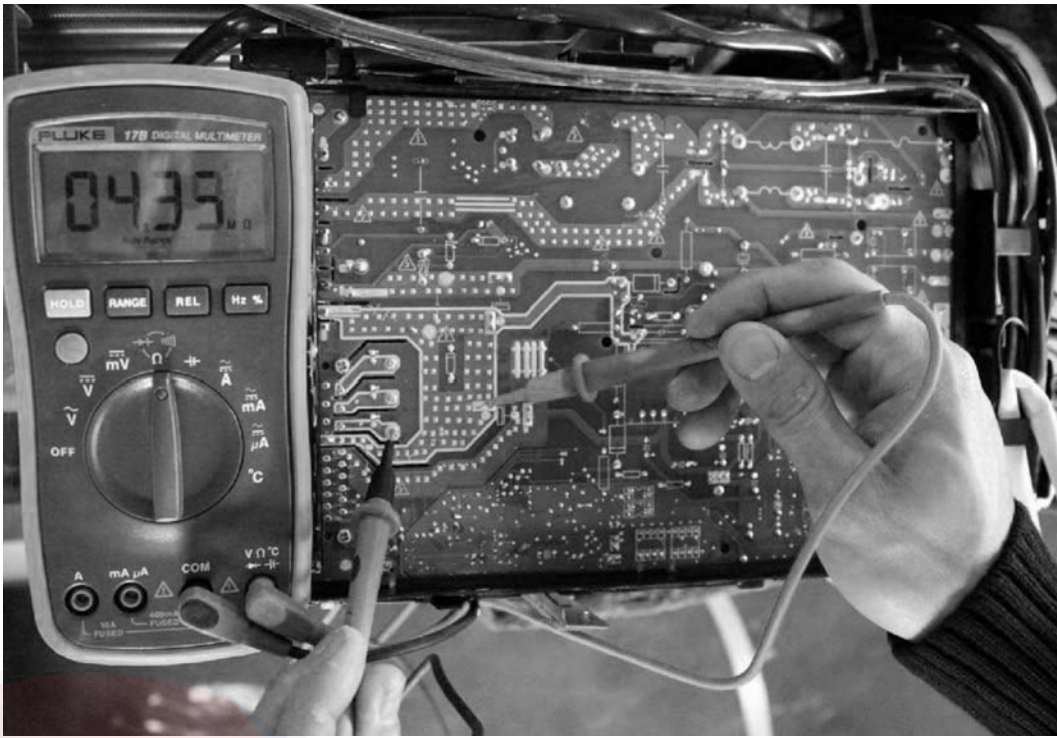

Fig. 41 – P-U

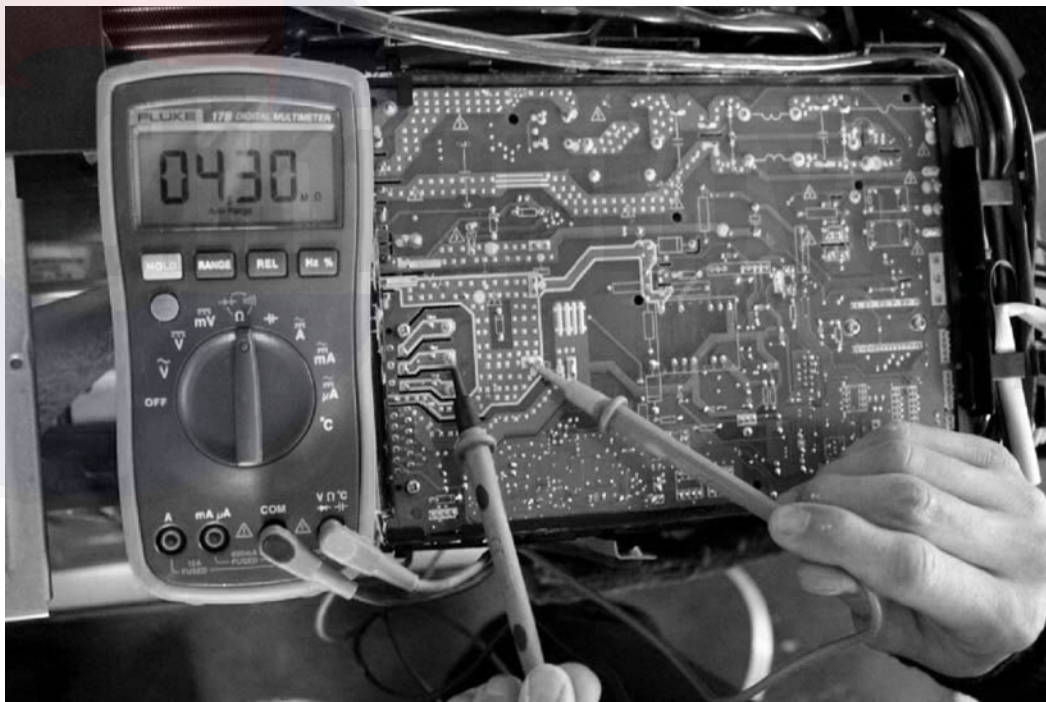

Fig. 42 – P-V

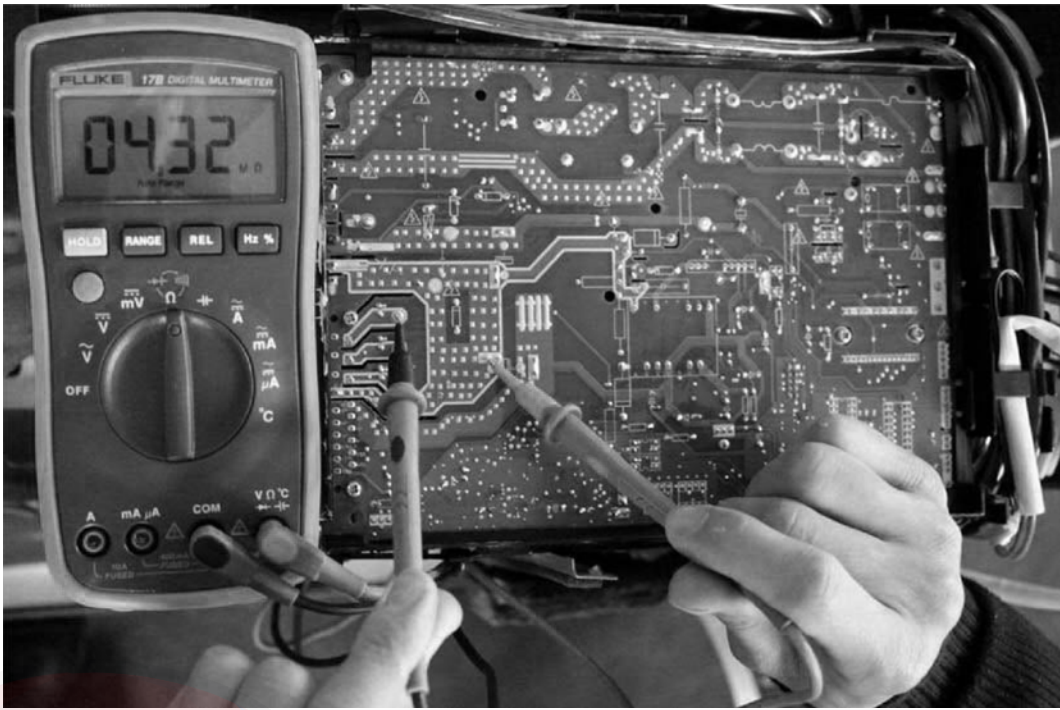

Fig. 43 – P-W

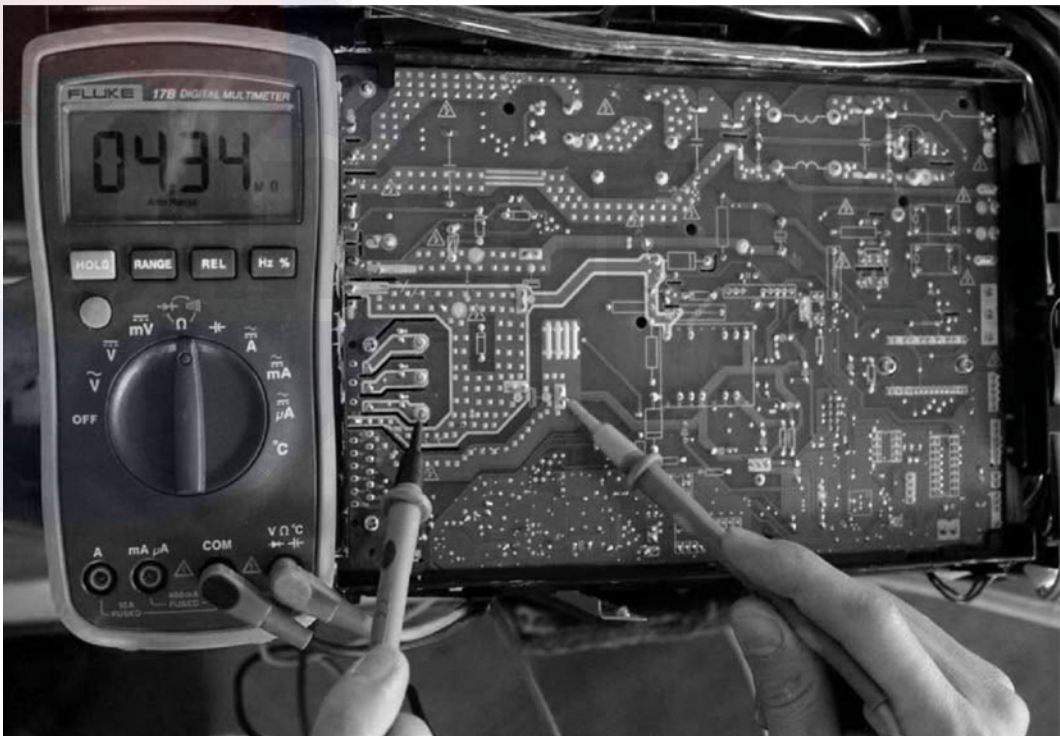

Fig. 44 – N-U



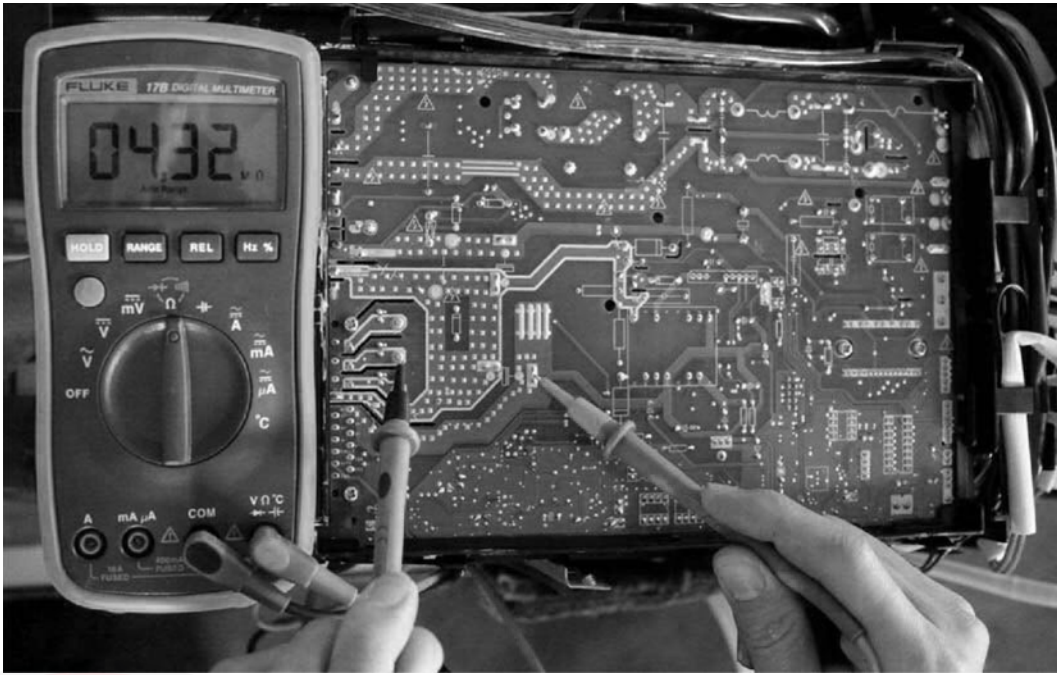

Fig. 45 – N-V

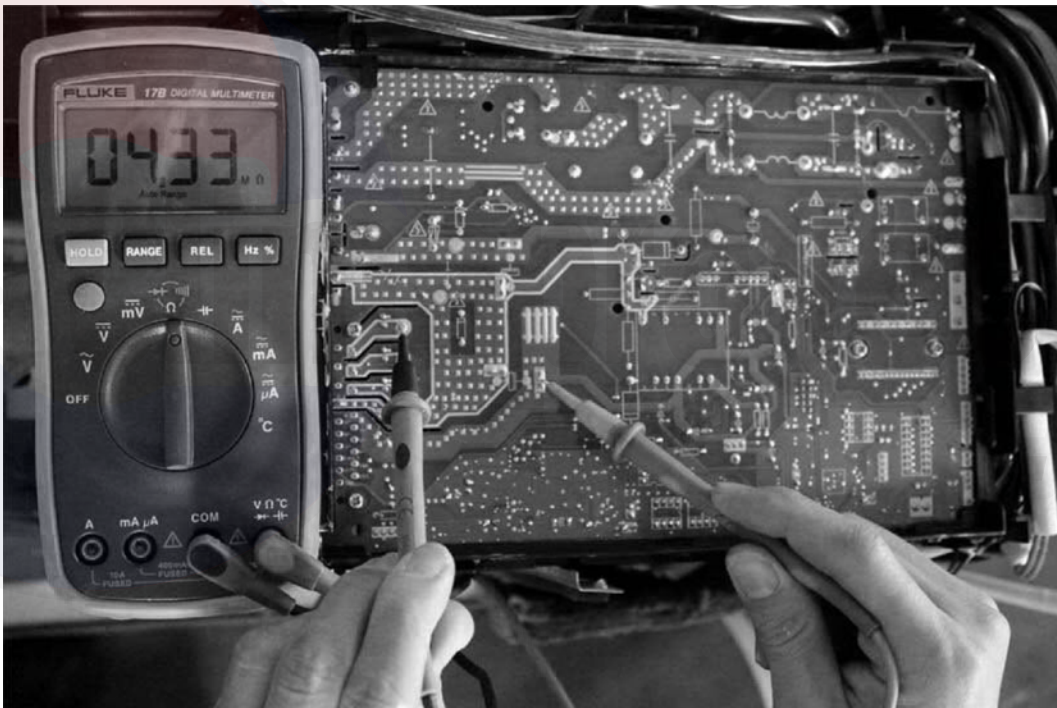
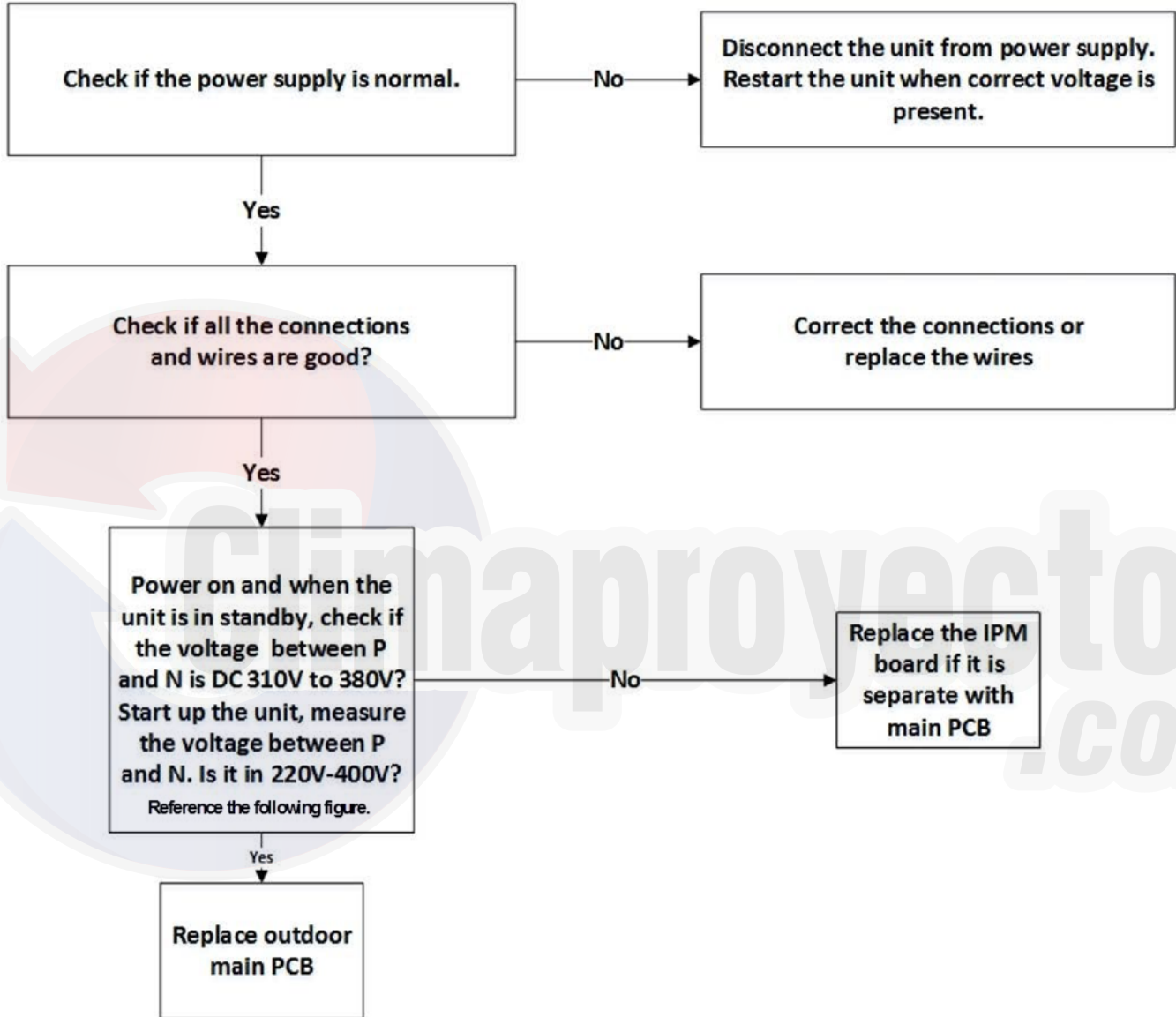

Fig. 46 – N-W

**Over voltage or too low voltage protection diagnosis and solution (P1)**

<b>Error Code</b>	<b>P1</b>
<b>Malfunction decision conditions</b>	An abnormal voltage rise or drop is detected by checking the specified voltage detection circuit.
<b>Supposed causes</b>	<ul style="list-style-type: none"> <li>• Power supply problems</li> <li>• System leakage or block</li> <li>• PCB faulty</li> </ul>

**Troubleshooting:**



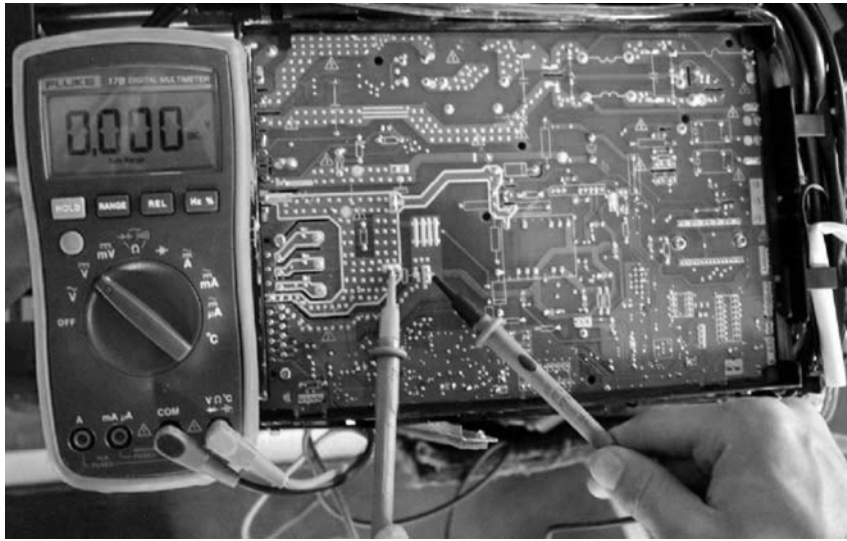

**Fig. 47 – Test**

**NOTE:** Measure the DC voltage between the P and N ports. The normal value should be around 310V.





**High temperature protection of compressor top diagnosis and solution (P2)**

<b>Error Code</b>	<b>P2</b>
Malfunction decision conditions	If the sampling voltage is not 5V, the LED will display the failure.
Supposed causes	<ul style="list-style-type: none"> <li>• Power supply problems</li> <li>• System leakage or block</li> <li>• PCB faulty</li> </ul>

**Troubleshooting**

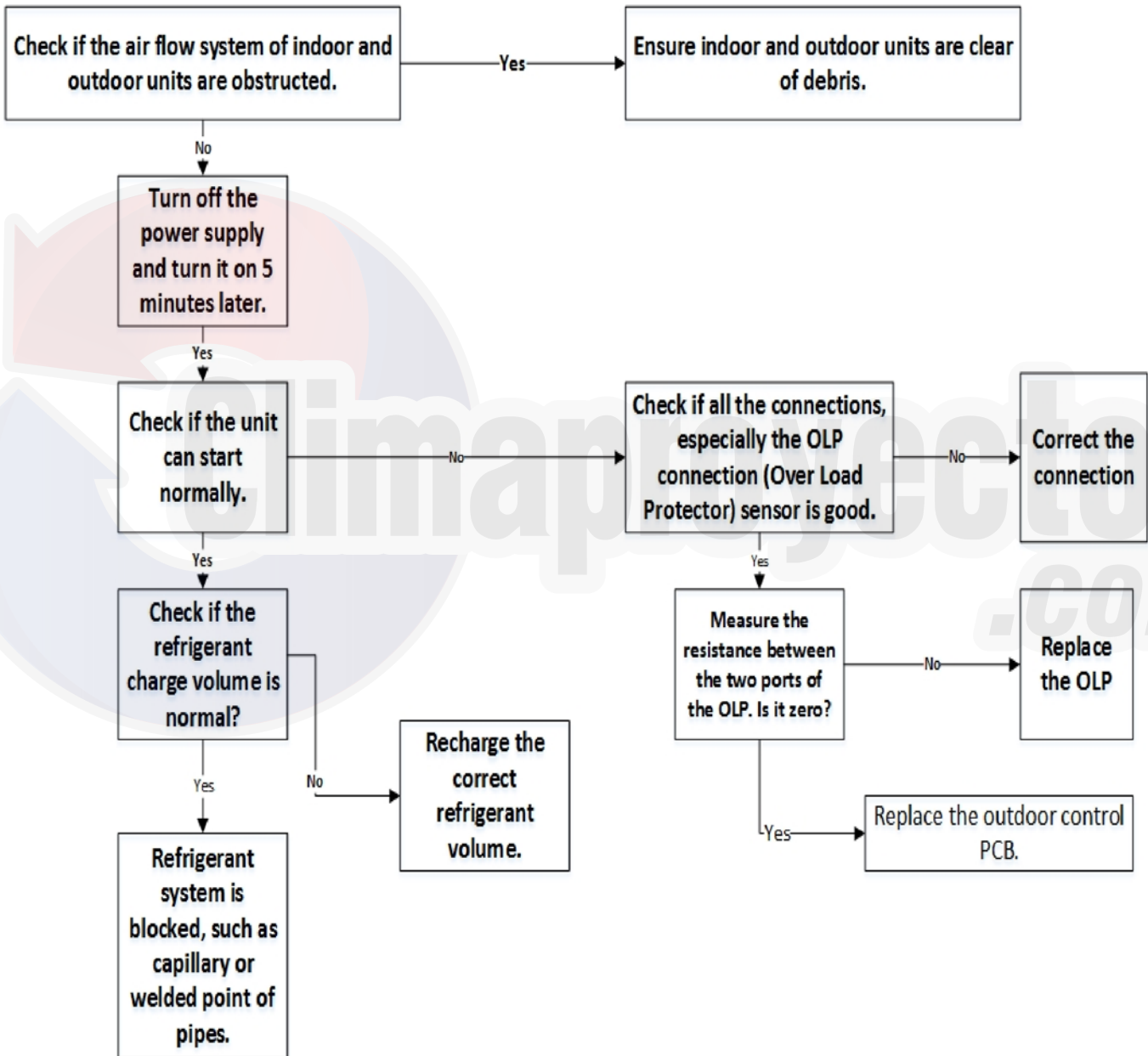

**Inverter compressor drive error diagnosis and solution(P4)**

<b>Error Code</b>	<b>P4</b>
<b>Malfunction decision conditions</b>	An abnormal inverter compressor drive is detected by a special detection circuit, including communication signal detection, voltage detection, compressor rotation speed signal detection and so on.
<b>Supposed causes</b>	<ul style="list-style-type: none"> <li>• Wiring mistake</li> <li>• IPM malfunction</li> <li>• Outdoor fan assembly fault</li> <li>• Compressor malfunction</li> <li>• Outdoor PCB faulty</li> </ul>

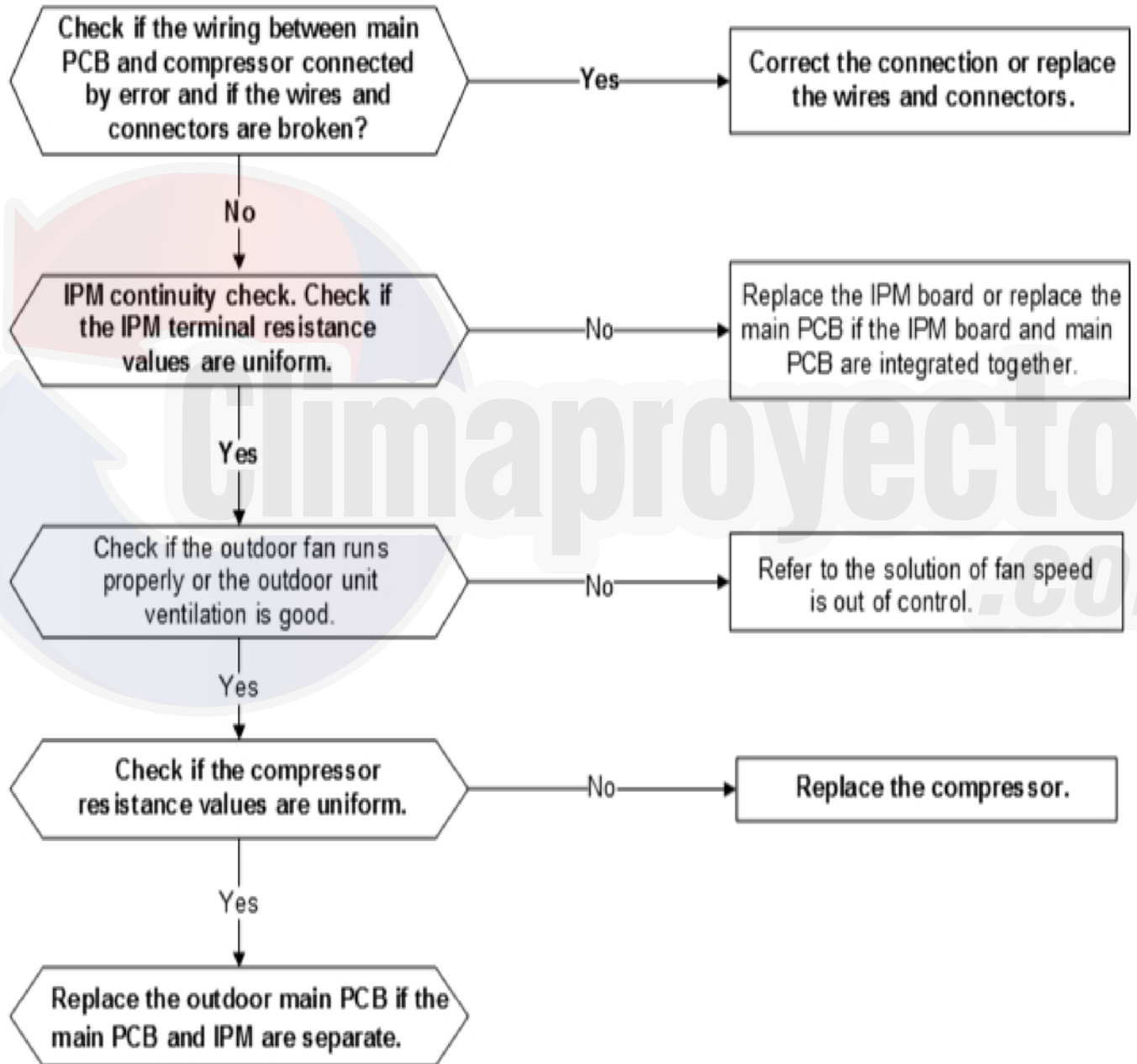

## Main parks check

### 1 Temperature sensor checking

Disconnect the temperature sensor from PCB, measure the resistance value with a tester.

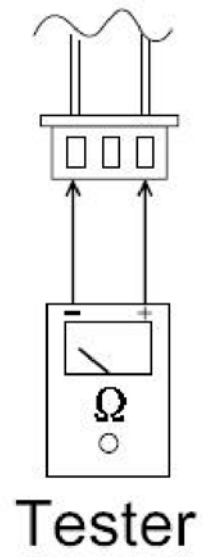

Fig. 48 – Tester

Temperature sensors.

- Room temp.
- (T1) sensor, Indoor coil temp.
- (T2) sensor, Outdoor coil temp.
- (T3) sensor, Outdoor ambient temp.
- (T4) sensor, Compressor discharge temp.
- (T5) sensor. Measure the resistance value of each winding by using the multi-meter.

## Compressor checking

Measure the resistance value of each winding by using the tester.

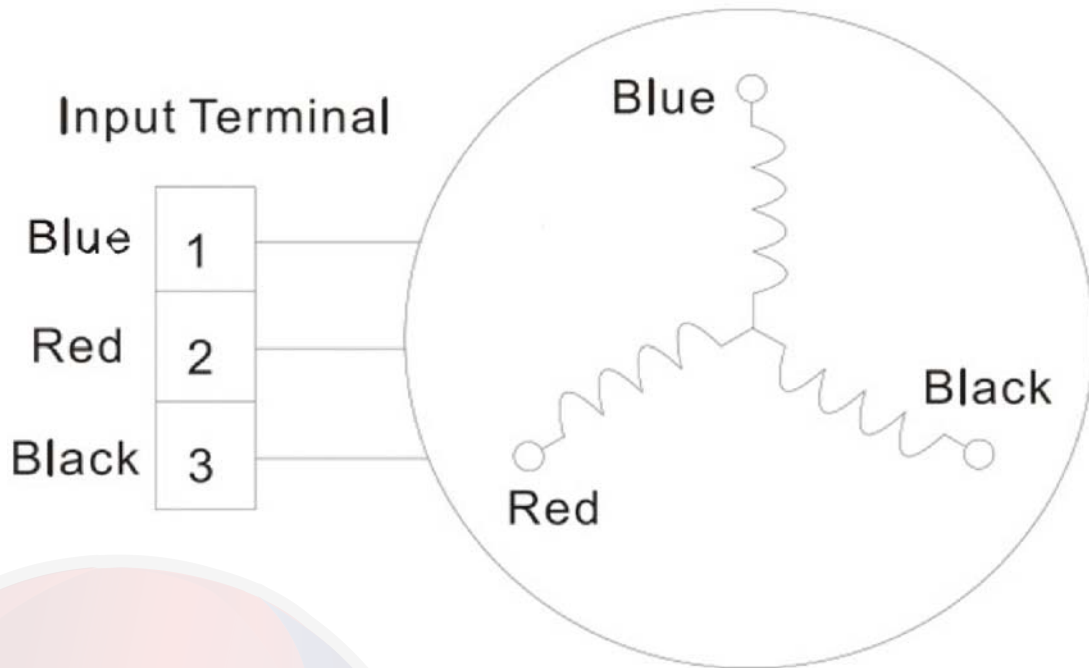

Fig. 49 – Tester

Terminal	Resistance Value		
	Terminal one	Terminal two	Terminal three
Blue - Red	0.8Ω (68°F/20°C)	1.77Ω (68°F/20°C)	0.55Ω (68°F/20°C)
Blue - Black			
Red - Blue			



Fig. 50 – Compressor checking

### IPM continuity check

Turn off the power, let the large capacity electrolytic capacitors discharge completely, and dismount the IPM. Use a digital tester to measure the resistance between P and UVWN; UVW and N.

Digital tester		Normal resistance value	Digital tester		Normal resistance value
(+)Red	(-)Black		(+)Red	(-)Black	
P	N	$\infty$ (Several M $\Omega$ )	U	N	$\infty$ (Several M $\Omega$ )
	U		V		
	V		W		
	W		(+)Red		

### Indoor AC Fan Motor

Measure the resistance value of each winding by using the tester.

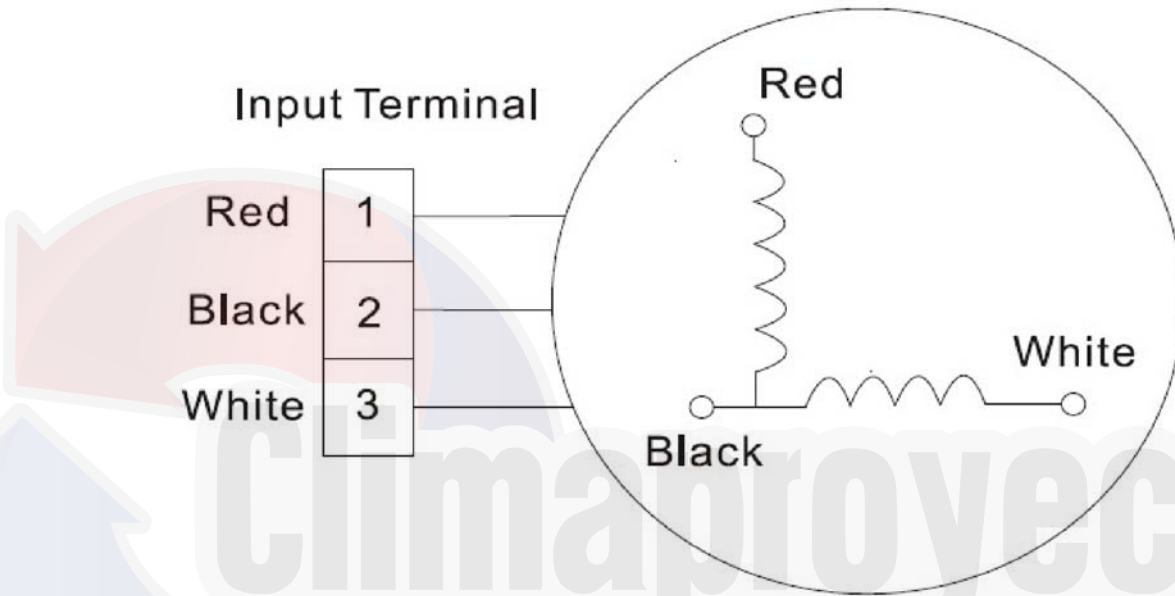

Fig. 51 – Indoor AC Fan Motor

Terminal	Resistance Value	
Black - Red	100.5 $\Omega$ ±8% (20°C /68°F) (Brand: Weiling)	100 $\Omega$ ±8% (20°C /68°F) (Brand: Dayang)
White - Black	64.5 $\Omega$ ±8% (20°C /68°F) (Brand: Weiling)	68.5 $\Omega$ ±8% (20°C /68°F) (Brand: Dayang)

# DISASSEMBLY INSTRUCTIONS

**NOTE:** This part is for reference only and the photos may differ from your unit.

## Indoor unit

No.	Parts name	Procedures	Remarks
1	Front panel	<p>How to remove the front panel.</p> <ol style="list-style-type: none"> <li>1) Pull the bottom side of the panel and release the clips. Then remove the front panel.</li> <li>2) Remove the filter and horizontal louver.</li> <li>3) Remove the four fixing screws.</li> <li>4) Remove the cover (one screw).</li> <li>5) Lift the panel frame and release the connector of display assembly. connectors. Then remove the panel frame assembly.</li> </ol>	<p><b>Overview:</b></p> <p>The 'Remarks' column contains three photographs illustrating the disassembly process. The top photograph shows the indoor unit with the front panel closed. The middle photograph shows the front panel being lifted away from the unit. Labels include 'Panel' pointing to the top of the panel, 'One screw fixing the cover' pointing to a screw on the right side, and 'Clip' pointing to two clips on the bottom edge. The bottom photograph shows the front panel removed, revealing the internal components. Labels include 'Clip' pointing to a clip on the left side, 'Filter' pointing to the air filter, 'Four screws' pointing to four screws on the front panel, and 'Connector for display ass'y' pointing to a connector on the right side.</p>

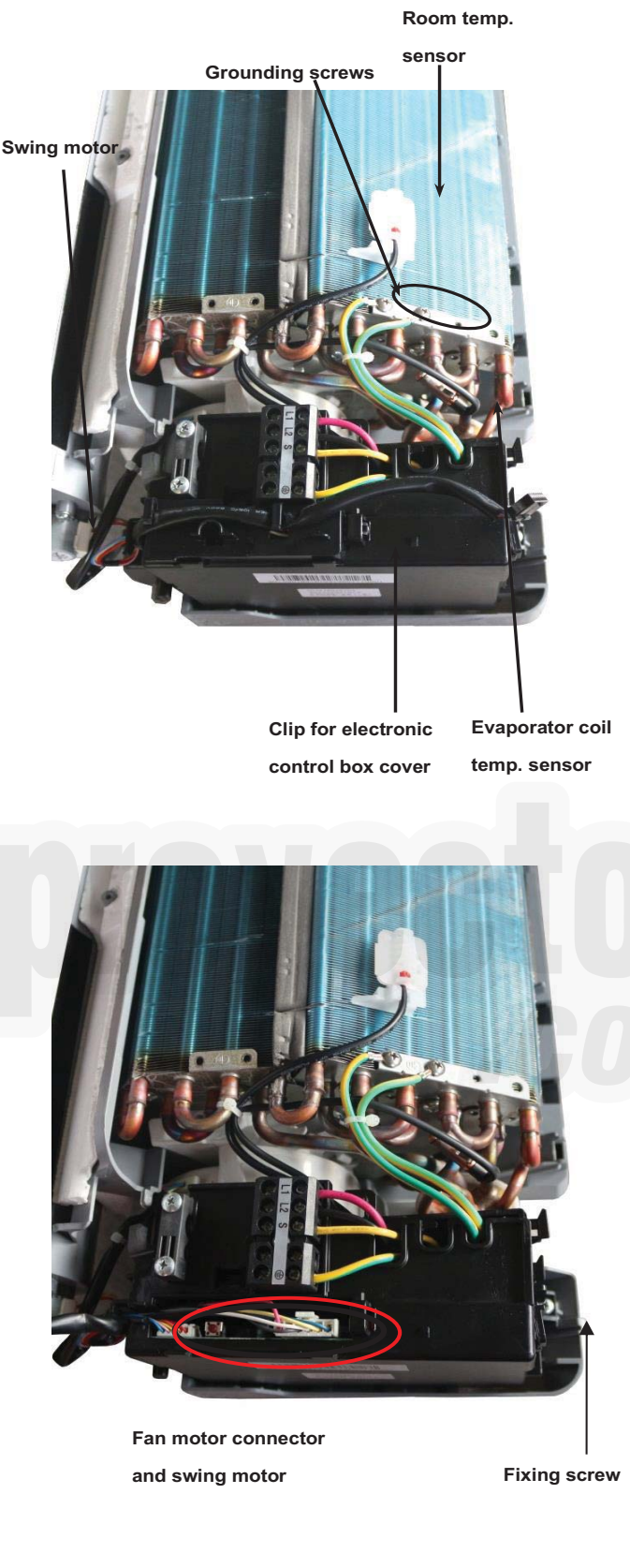

<p>2</p>	<p>Electrical parts</p>	<p>How to remove the electrical parts.</p> <p>1) After removing the front panel from procedure 1, pull out the room temp. sensor and evaporator coil sensor. Remove the grounding screws.</p> <p>2) Pull out the clip toward the left side and open the cover.</p> <p>3) Remove the fixing screw and open the electrical box cover.</p> <p>4) Pull out the connectors of the swing motor and fan motor .</p> <p>5) Remove the fixing screw and then remove the electronic control box and air outlet assembly.</p>	 <p>Room temp. sensor</p> <p>Grounding screws</p> <p>Swing motor</p> <p>Clip for electronic control box cover</p> <p>Evaporator coil temp. sensor</p> <p>Fan motor connector and swing motor</p> <p>Fixing screw</p>
----------	-------------------------	--	---

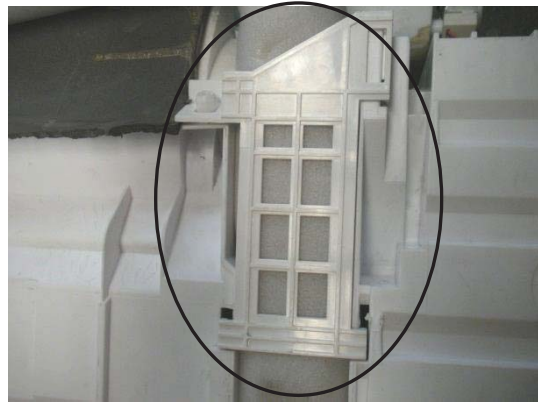

3	Evaporator	<p>How to remove the evaporator.</p> <p>1) After removing front panel ass'y and electrical parts following procedure 1 and procedure 2, remove the pipe holder at the rear side of the unit.</p> <p>2) Remove the two screws on the evaporator at the base bearing side.</p> <p>3) Remove two screws on the evaporator at the fixed plates and then lift the evaporator ass'y.</p>
---	------------	--

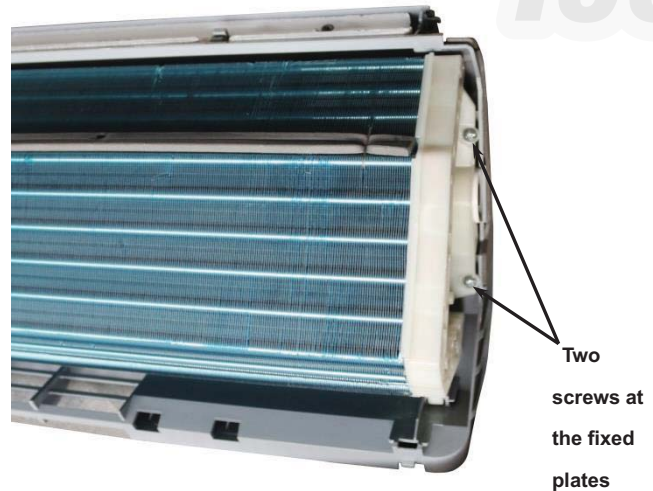

Two screws at the base bearing side



Two screws at the fixed plates

4	Fan and motor	<p>How to remove the fan and motor.</p> <p>1) After remove the evaporator ass'y following procedure 1, procedure 2 and procedure 3, remove the three screws fixing the cover</p> <p>2) Remove the screw fixing the motor and then pull out the motor.</p>	 <p>Three screws</p>  <p>One screw</p>
---	---------------	---	---

# OUTDOOR UNIT

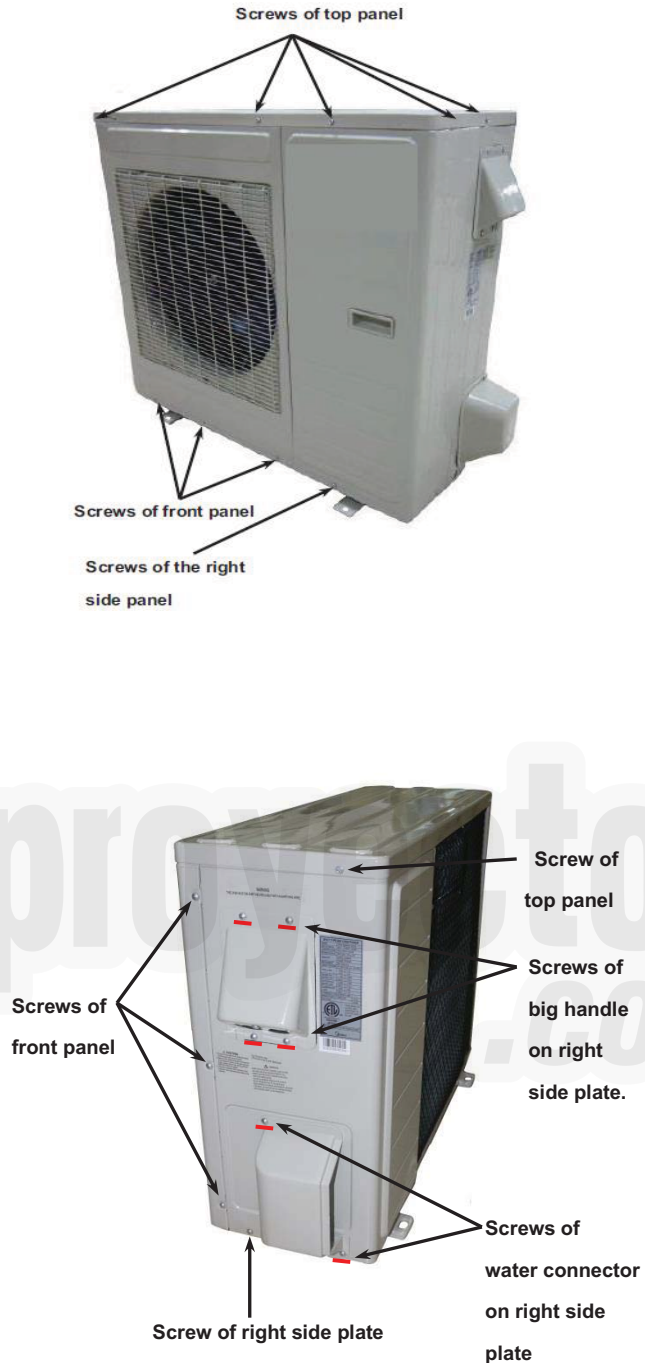
No.	Part name	Procedures	Remarks
1	Panel plate	<p>How to remove the panel plate.</p> <p>1) Stop operation of the air conditioner and turn "OFF" the breaker.</p> <p>2) Refer to the photos on the right to locate screws on the panels.</p> <p>3) Remove the screws of top panel and remove the top panel.</p>	 <p>Screws of top panel</p> <p>Screws of front panel</p> <p>Screws of the right side panel</p> <p>Screw of top panel</p> <p>Screws of front panel</p> <p>Screws of big handle on right side plate.</p> <p>Screw of right side plate</p> <p>Screws of water connector on right side plate</p>



4) Remove the screws of the front panel, including the fixing screws of motor holder and then remove the front panel.



5) Remove the screws of the right side plate and remove the right side plate.



2

Fan ass'y

How. to remove the fan assembly

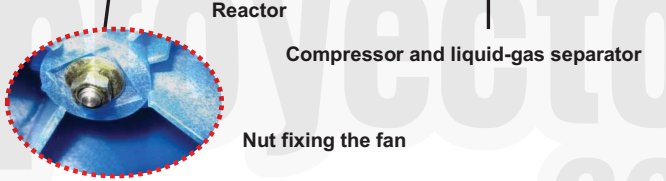
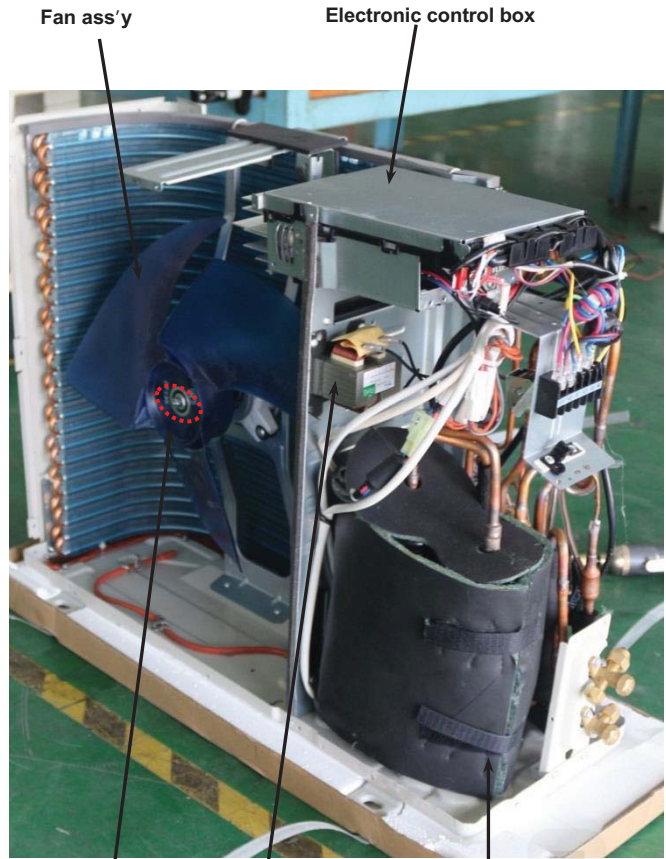

1) After removing the panel plate following procedure 1, remove the hex nut fixing the fan and then remove the fan.

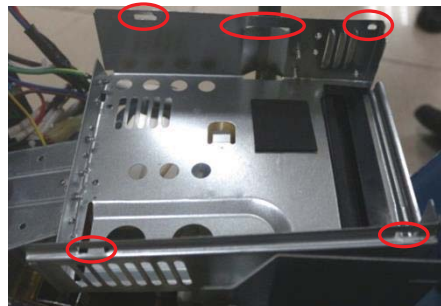
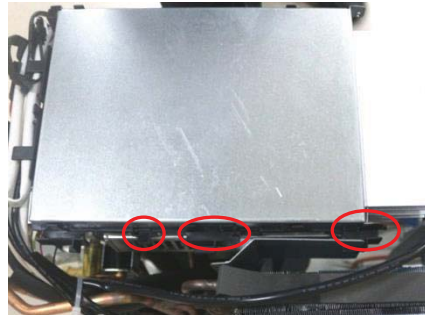

2) Unfix the hooks and then open the electronic control box cover.



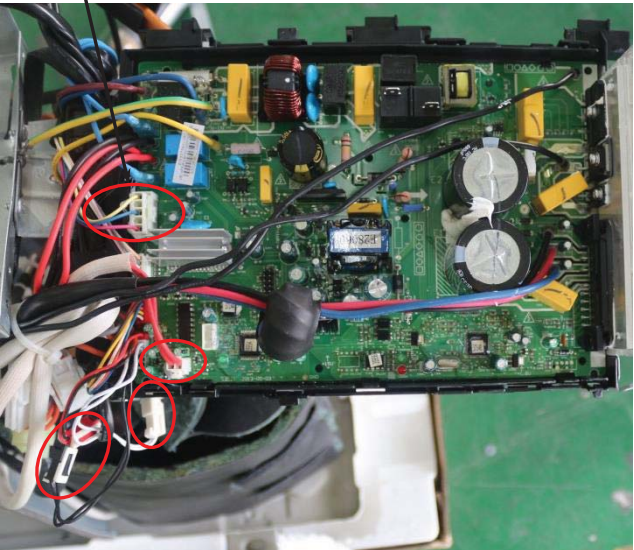

		<p>3) Disconnect the connector for fan motor from the electronic control board.</p> <p>4) Remove the four fixing screws of the fan motor.</p> <p>5) Then remove the fan motor.</p>	<p>Fan motor connector</p>   <p>Four screws</p>
3	Electrical parts	<p>How to remove the electrical parts.</p> <p>1) After finish work of item 1 and item 2, remove the three connectors for the compressor and electrical heaters.</p> <p>2) Release the connector of the reactor.</p>	 <p>Reactor connector</p> <p>Compressor connector and electrical heater connector</p> <p>Two blue wires of four way valve</p>

3) Pull out the two blue wires connected with the four way valve.

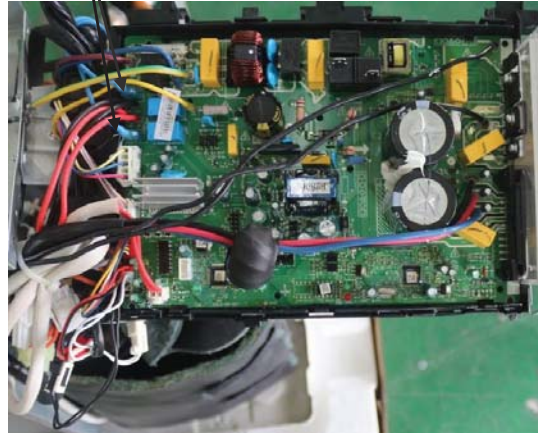

4) Pull out connectors of the compressor top temp. sensor, condenser coil temp. sensor(T3), outdoor ambient temp. sensor(T4) and discharge temp. sensor(T5).

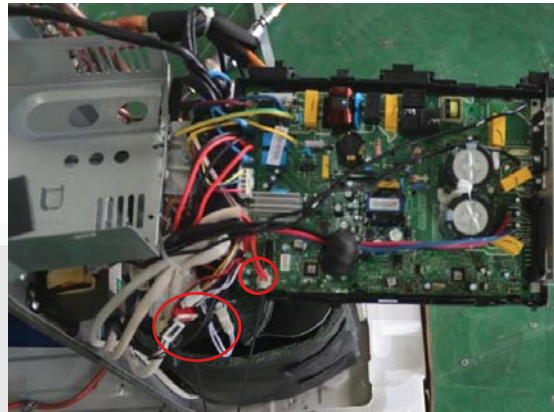



Four connectors of temp. sensors.

5) Remove the ground wires .

6) Remove the power supply wires(L1,L2,S).

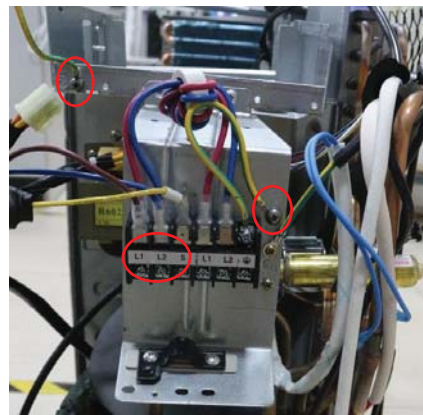
7) Then remove the electronic control box.

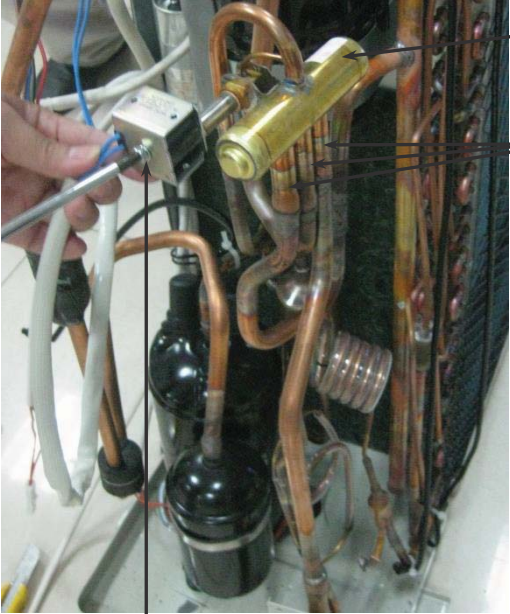

4	Four-way valve	<p>How to remove the four-way valve.</p> <ol style="list-style-type: none"> <li>1) Perform work of item 1,2,3.</li> <li>2) Recover refrigerant from the refrigerant circuit.</li> <li>3) Remove the screw of the coil and then remove the coil.</li> <li>4) Detach the welded parts of four-way valve and pipe.</li> <li>5) Then the four-way valve ass'y can be removed</li> </ol>	<p>The picture of four-way valve may be different from the one on your side.</p>  <p>Four-way valve</p> <p>Welded parts</p> <p>Coil of four-way valve, fixing by one screw.</p>
5	Compressor	<p>How to remove the compressor.</p> <ol style="list-style-type: none"> <li>1) After performing work of item 1,2,3.</li> <li>2) Remove the discharge pipe and suction pipe with a torch.</li> <li>3) Remove the hex nuts and washers fixing the compressor on bottom plate.</li> <li>4) Lift the compressor from the base pan assembly.</li> </ol>	 <p>Discharge pipe and suction pipe</p> <p>Nuts of compress</p>



# APPENDIX 1

Temperature Sensor Resistance Value Table for T1, T2, T3, T4 (°C--K)

°C	°F	K Ohm	°C	°F	K Ohm	°C	°F	K Ohm	°C	°F	K Ohm
-20	-4	115.266	20	68	12.6431	60	140	2.35774	100	212	0.62973
-19	-2	108.146	21	70	12.0561	61	142	2.27249	101	214	0.61148
-18	0	101.517	22	72	11.5	62	144	2.19073	102	216	0.59386
-17	1	96.3423	23	73	10.9731	63	145	2.11241	103	217	0.57683
-16	3	89.5865	24	75	10.4736	64	147	2.03732	104	219	0.56038
-15	5	84.219	25	77	10	65	149	1.96532	105	221	0.54448
-14	7	79.311	26	79	9.55074	66	151	1.89627	106	223	0.52912
-13	9	74.536	27	81	9.12445	67	153	1.83003	107	225	0.51426
-12	10	70.1698	28	82	8.71983	68	154	1.76647	108	226	0.49989
-11	12	66.0898	29	84	8.33566	69	156	1.70547	109	228	0.486
-10	14	62.2756	30	86	7.97078	70	158	1.64691	110	230	0.47256
-9	16	58.7079	31	88	7.62411	71	160	1.59068	111	232	0.45957
-8	18	56.3694	32	90	7.29464	72	162	1.53668	112	234	0.44699
-7	19	52.2438	33	91	6.98142	73	163	1.48481	113	235	0.43482
-6	21	49.3161	34	93	6.68355	74	165	1.43498	114	237	0.42304
-5	23	46.5725	35	95	6.40021	75	167	1.38703	115	239	0.41164
-4	25	44	36	97	6.13059	76	169	1.34105	116	241	0.4006
-3	27	41.5878	37	99	5.87359	77	171	1.29078	117	243	0.38991
-2	28	39.8239	38	100	5.62961	78	172	1.25423	118	244	0.37956
-1	30	37.1988	39	102	5.39689	79	174	1.2133	119	246	0.36954
0	32	35.2024	40	104	5.17519	80	176	1.17393	120	248	0.35982
1	34	33.3269	41	106	4.96392	81	178	1.13604	121	250	0.35042
2	36	31.5635	42	108	4.76253	82	180	1.09958	122	252	0.3413
3	37	29.9058	43	109	4.5705	83	181	1.06448	123	253	0.33246
4	39	28.3459	44	111	4.38736	84	183	1.03069	124	255	0.3239
5	41	26.8778	45	113	4.21263	85	185	0.99815	125	257	0.31559
6	43	25.4954	46	115	4.04589	86	187	0.96681	126	259	0.30754
7	45	24.1932	47	117	3.88673	87	189	0.93662	127	261	0.29974
8	46	22.5662	48	118	3.73476	88	190	0.90753	128	262	0.29216
9	48	21.8094	49	120	3.58962	89	192	0.8795	129	264	0.28482
10	50	20.7184	50	122	3.45097	90	194	0.85248	130	266	0.2777
11	52	19.6891	51	124	3.31847	91	196	0.82643	131	268	0.27078
12	54	18.7177	52	126	3.19183	92	198	0.80132	132	270	0.26408
13	55	17.8005	53	127	3.07075	93	199	0.77709	133	271	0.25757
14	57	16.9341	54	129	2.95896	94	201	0.75373	134	273	0.25125
15	59	16.1156	55	131	2.84421	95	203	0.73119	135	275	0.24512
16	61	15.3418	56	133	2.73823	96	205	0.70944	136	277	0.23916
17	63	14.6181	57	135	2.63682	97	207	0.68844	137	279	0.23338
18	64	13.918	58	136	2.53973	98	208	0.66818	138	280	0.22776
19	66	13.2631	59	138	2.44677	99	210	0.64862	139	282	0.22231

## APPENDIX 2

Temperature Sensor Resistance Value Table for T5 (°C--K)

°C	°F	K Ohm	°C	°F	K Ohm	°C	°F	K Ohm	°C	°F	K Ohm
-20	-4	542.7	20	68	68.66	60	140	13.59	100	212	3.702
-19	-2	511.9	21	70	65.62	61	142	13.11	101	214	3.595
-18	0	483	22	72	62.73	62	144	12.65	102	216	3.492
-17	1	455.9	23	73	59.98	63	145	12.21	103	217	3.392
-16	3	430.5	24	75	57.37	64	147	11.79	104	219	3.296
-15	5	406.7	25	77	54.89	65	149	11.38	105	221	3.203
-14	7	384.3	26	79	52.53	66	151	10.99	106	223	3.113
-13	9	363.3	27	81	50.28	67	153	10.61	107	225	3.025
-12	10	343.6	28	82	48.14	68	154	10.25	108	226	2.941
-11	12	325.1	29	84	46.11	69	156	9.902	109	228	2.86
-10	14	307.7	30	86	44.17	70	158	9.569	110	230	2.781
-9	16	291.3	31	88	42.33	71	160	9.248	111	232	2.704
-8	18	275.9	32	90	40.57	72	162	8.94	112	234	2.63
-7	19	261.4	33	91	38.89	73	163	8.643	113	235	2.559
-6	21	247.8	34	93	37.3	74	165	8.358	114	237	2.489
-5	23	234.9	35	95	35.78	75	167	8.084	115	239	2.422
-4	25	222.8	36	97	34.32	76	169	7.82	116	241	2.357
-3	27	211.4	37	99	32.94	77	171	7.566	117	243	2.294
-2	28	200.7	38	100	31.62	78	172	7.321	118	244	2.233
-1	30	190.5	39	102	30.36	79	174	7.086	119	246	2.174
0	32	180.9	40	104	29.15	80	176	6.859	120	248	2.117
1	34	171.9	41	106	28	81	178	6.641	121	250	2.061
2	36	163.3	42	108	26.9	82	180	6.43	122	252	2.007
3	37	155.2	43	109	25.86	83	181	6.228	123	253	1.955
4	39	147.6	44	111	24.85	84	183	6.033	124	255	1.905
5	41	140.4	45	113	23.89	85	185	5.844	125	257	1.856
6	43	133.5	46	115	22.89	86	187	5.663	126	259	1.808
7	45	127.1	47	117	22.1	87	189	5.488	127	261	1.762
8	46	121	48	118	21.26	88	190	5.32	128	262	1.717
9	48	115.2	49	120	20.46	89	192	5.157	129	264	1.674
10	50	109.8	50	122	19.69	90	194	5	130	266	1.632
11	52	104.6	51	124	18.96	91	196	4.849			
12	54	99.69	52	126	18.26	92	198	4.703			
13	55	95.05	53	127	17.58	93	199	4.562			
14	57	90.66	54	129	16.94	94	201	4.426			
15	59	86.49	55	131	16.32	95	203	4.294			
16	61	82.54	56	133	15.73	96	205	4.167			
17	63	78.79	57	135	15.16	97	207	4.045			
18	64	75.24	58	136	14.62	98	208	3.927			
19	66	71.86	59	138	14.09	99	210	3.812			

### APPENDIX 3

°C	°F	°C	°F	°C	°F	°C	°F	°C	°F
-5	23	21	69.8	51	123.8	82	179.6	113	235.4
-4	24.8	22	71.6	52	125.6	83	181.4	114	237.2
-3	26.6	23	73.4	53	127.4	84	183.2	115	239
-2	28.4	24	75.2	54	129.2	85	185	116	240.8
-1	30.2	25	77	55	131	86	186.8	117	242.6
0	32	25.5	77.9	56	132.8	87	188.6	118	244.4
0.5	32.9	26	78.8	57	134.6	88	190.4	119	246.2
1	33.8	27	80.6	58	136.4	89	192.2	120	248
1.5	34.7	28	82.4	59	138.2	90	194	121	249.8
2	35.6	29	84.2	60	140	91	195.8	122	251.6
2.5	36.5	30	86	61	141.8	92	197.6	123	253.4
3	37.4	31	87.8	62	143.6	93	199.4	124	255.2
3.5	38.3	32	89.6	63	145.4	94	201.2	125	257
4	39.2	33	91.4	64	147.2	95	203	126	258.8
4.5	40.1	34	93.2	65	149	96	204.8	127	260.6
5	41	35	95	66	150.8	97	206.6	128	262.4
6	42.8	36	96.8	67	152.6	98	208.4	129	264.2
7	44.6	37	98.6	68	154.4	99	210.2	130	266
8	46.4	38	100.4	69	156.2	100	212	131	267.8
9	48.2	39	102.2	70	158	101	213.8	132	269.6
10	50	40	104	71	159.8	102	215.6	133	271.4
11	51.8	41	105.8	72	161.6	103	217.4	134	273.2
12	53.6	42	107.6	73	163.4	104	219.2	135	275
13	55.4	43	109.4	74	165.2	105	221	136	276.8
14	57.2	44	111.2	75	167	106	222.8	137	278.6
15	59	45	113	76	168.8	107	224.6	138	280.4
16	60.8	46	114.8	77	170.6	108	226.4	139	282.2
17	62.6	47	116.6	78	172.4	109	228.2	140	284
18	64.4	48	118.4	79	174.2	110	230	141	285.8
19	66.2	49	120.2	80	176	111	231.8	142	287.6
20	68	50	122	81	177.8	112	233.6	143	289.4

