



INSTALLATION INSTRUCTIONS

T-CLASS™ TAA SERIES

AIR HANDLERS
6 TO 20 TONS
506149-01
04/11
Supersedes 8/09

TP Technical
Publications
Litho U.S.A.

**RETAIN THESE INSTRUCTIONS
FOR FUTURE REFERENCE**

⚠ WARNING

Improper installation, adjustment, alteration, service or maintenance can cause personal injury, loss of life, or damage to property.

Installation and service must be performed by a licensed professional installer (or equivalent) or a service agency.

⚠ CAUTION

Physical contact with metal edges and corners while applying excessive force or rapid motion can result in personal injury. Be aware of, and use caution when working near these areas during installation or while servicing this equipment.

⚠ IMPORTANT

The Clean Air Act of 1990 bans the intentional venting of refrigerant (CFCs, HCFCs and HFCs) as of July 1, 1992. Approved methods of recovery, recycling or reclaiming must be followed. Fines and/or incarceration may be levied for noncompliance.

⚠ WARNING

Electric Shock Hazard.

Can cause injury or death.

Foil-faced insulation has conductive characteristics similar to metal. Be sure there are no electrical connections within a ½" of the insulation. If the foil-faced insulation comes in contact with electrical voltage, the foil could provide a path for current to pass through to the outer metal cabinet. While the current produced may not be enough to trip existing electrical safety devices (e.g. fuses or circuit breakers), the current can be enough to cause an electric shock hazard that could cause personal injury or death.

Table of Contents

General	1
Shipping and Packing List	1
TAA072 and TAA090 Unit Dimensions	2
TAA120 and TAA150 Unit Dimensions	3
TAA180 and TAA240 Unit Dimensions	4
Unit Parts Arrangement	5
Unit Control Box Components Arrangement	6
Typical Installation Support Method	6
Requirements	7
Refrigerant Piping Connections	7
Installing Condensate Drain	8
Duct Connections	10
Sealing the Unit	11
Wiring	11
Blower Motor Belt Tensioning Adjustment	12
Pulley Alignment	13
Air Volume Adjustment	13
Blower Data	14
Blower Drive Components	15
Blower Performance	16
Repairing or Replacing Cabinet Insulation	20
Optional Accessories	20

General

The TAA Series air handler units are designed for installation with a matched remote outdoor unit that is charged with HFC-410A refrigerant and optional field-installed electric heat. The air handler units are for indoor installation only and are designed for upflow or horizontal applications.

Shipping and Packing List

Package contains the following:

1 — Assembled blower coil unit

8 — Supply and return air flanges which are stored inside unit and are listed in table 2, on page 9.

1 — Bag assembly that consists of the following:

- One installation instruction
- Two wiring diagrams (unit wiring and thermostat connections)
- Six plastic grommets (various sizes) for line set knockouts.

Check package contents for shipping damage; if found, immediately report damage to the last carrier.



TAA072 and TAA090 Unit Dimensions - Inches (mm)

Model No.	CORNER WEIGHTS								CENTER OF GRAVITY			
	AA		BB		CC		DD		EE		FF	
	lbs.	kg	lbs.	kg	lbs.	kg	lbs.	kg	in.	mm	in.	mm
TAA072	88	40	88	40	88	40	88	40	25-1/2	648	25-1/2	648
TAA090	88	40	88	40	88	40	88	40	25-1/2	648	25-1/2	648

UP-FLOW POSITION SHOWN

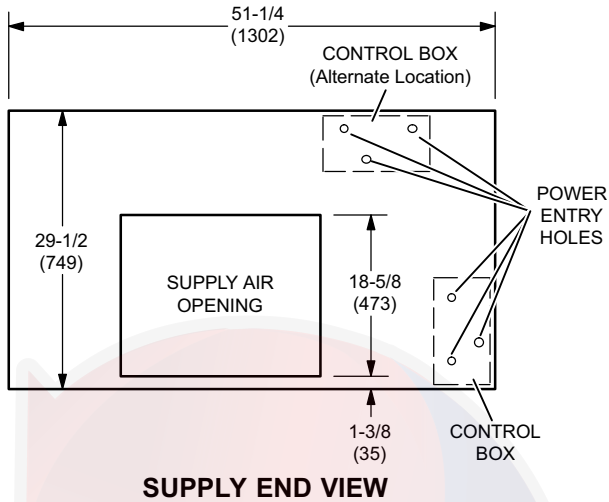

NOTE:
072 models only use one Suction and Liquid Line. Cabinet has knockouts for two. Either opening may be used.

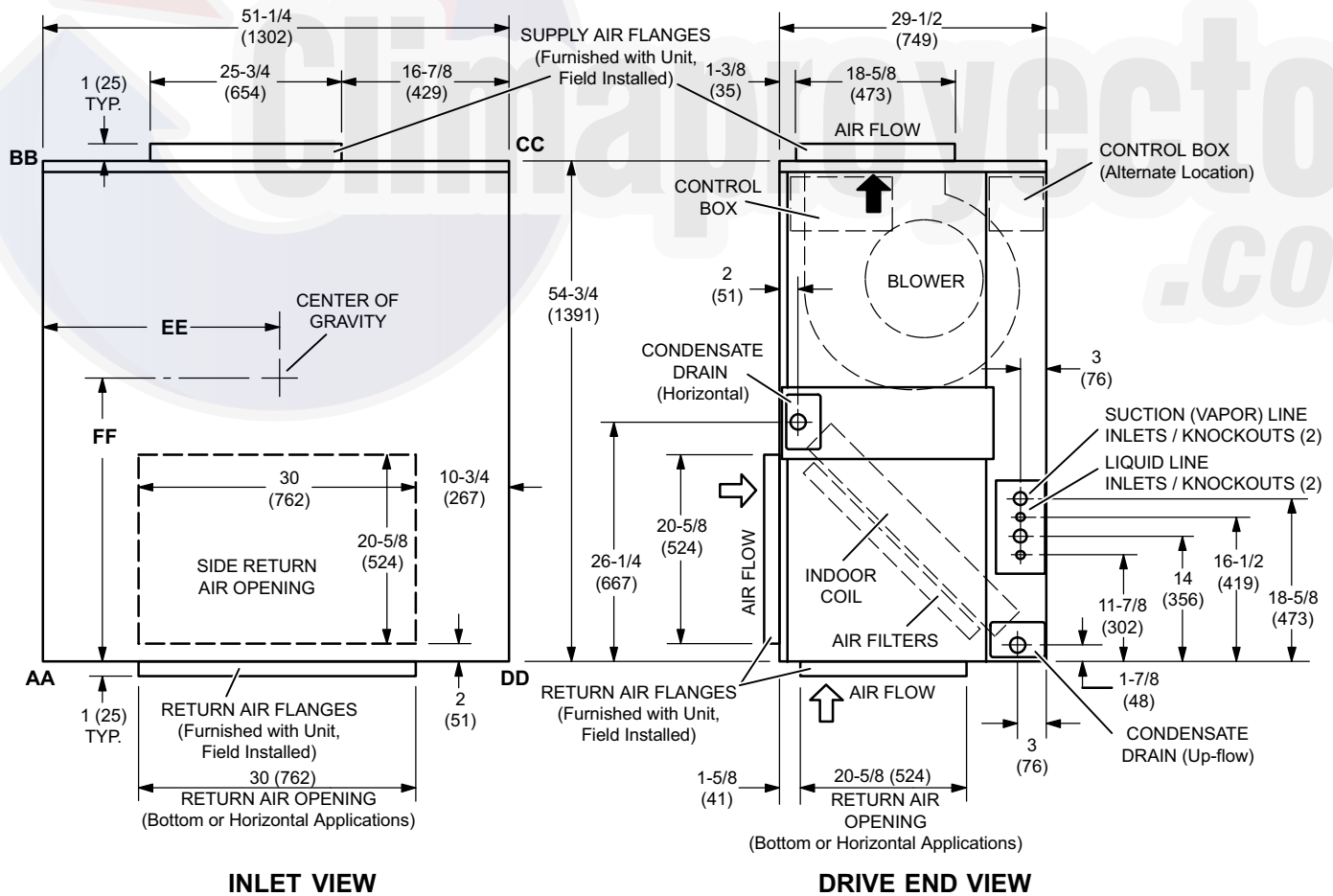

TAA120 and TAA150 Dimensions - Inches (mm)

Model No.	CORNER WEIGHTS								CENTER OF GRAVITY			
	AA		BB		CC		DD		EE		FF	
	lbs.	kg	lbs.	kg	lbs.	kg	lbs.	kg	in.	mm	in.	mm
TAA120-150	126	57	101	46	101	46	126	57	33-1/2	851	24-1/2	622

UP-FLOW POSITION SHOWN

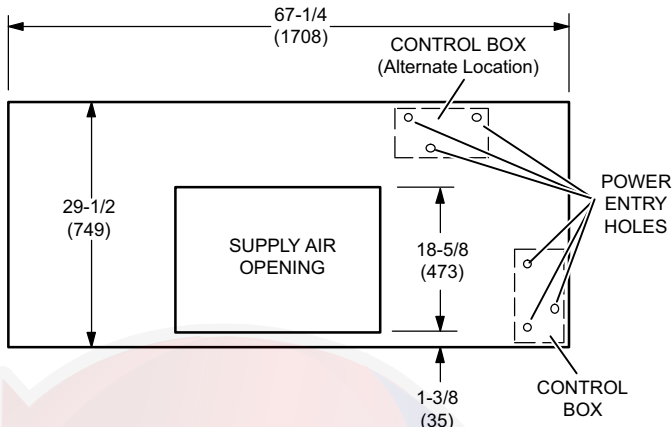

SUPPLY END VIEW

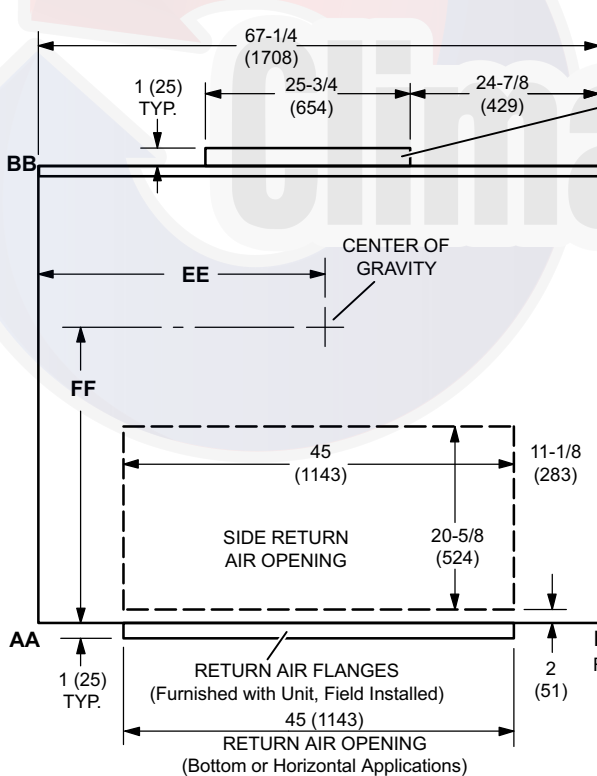

INLET VIEW

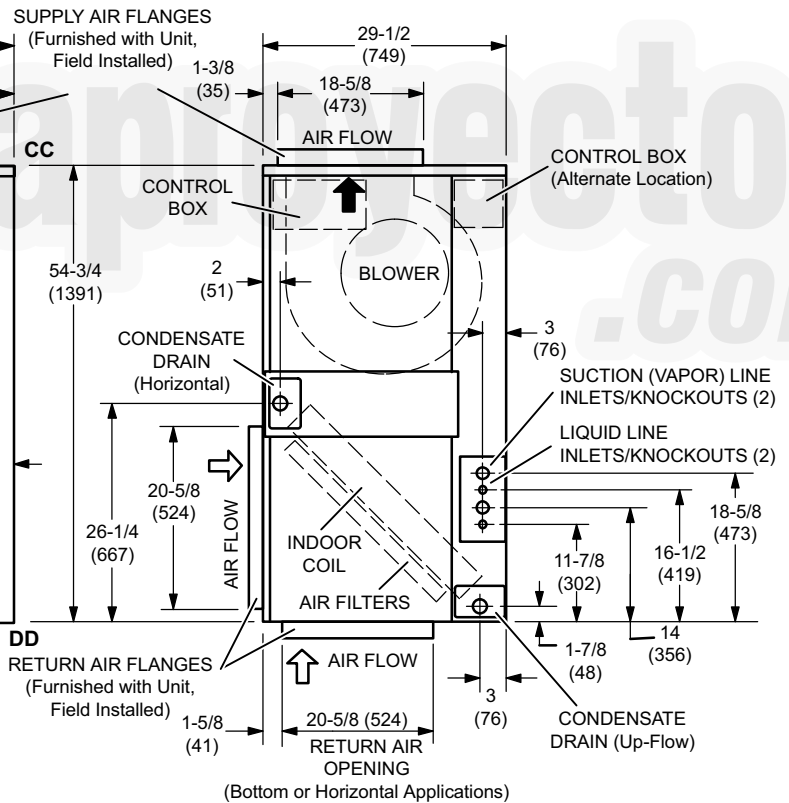

DRIVE END VIEW

TAA 180 and TAA 240 Unit Dimensions - Inches (mm)

Model No.	CORNER WEIGHTS								CENTER OF GRAVITY			
	AA		BB		CC		DD		EE		FF	
	lbs.	kg	lbs.	kg	lbs.	kg	lbs.	kg	in.	mm	in.	mm
TAA180-240	110	50	99	45	116	53	130	59	52	1321	25-3/4	654

UP-FLOW POSITION SHOWN

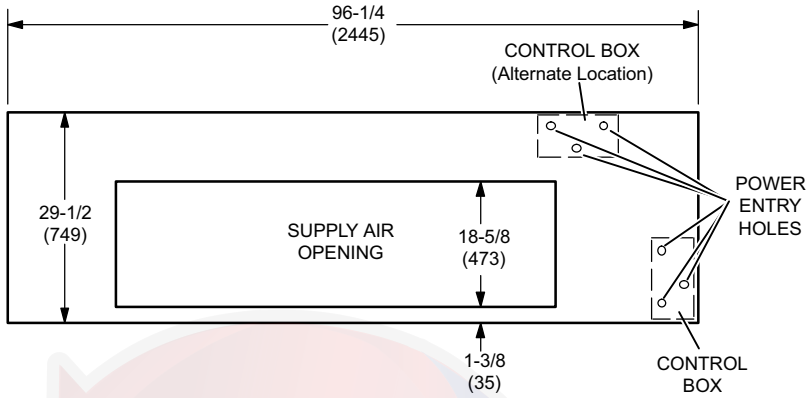

SUPPLY END VIEW

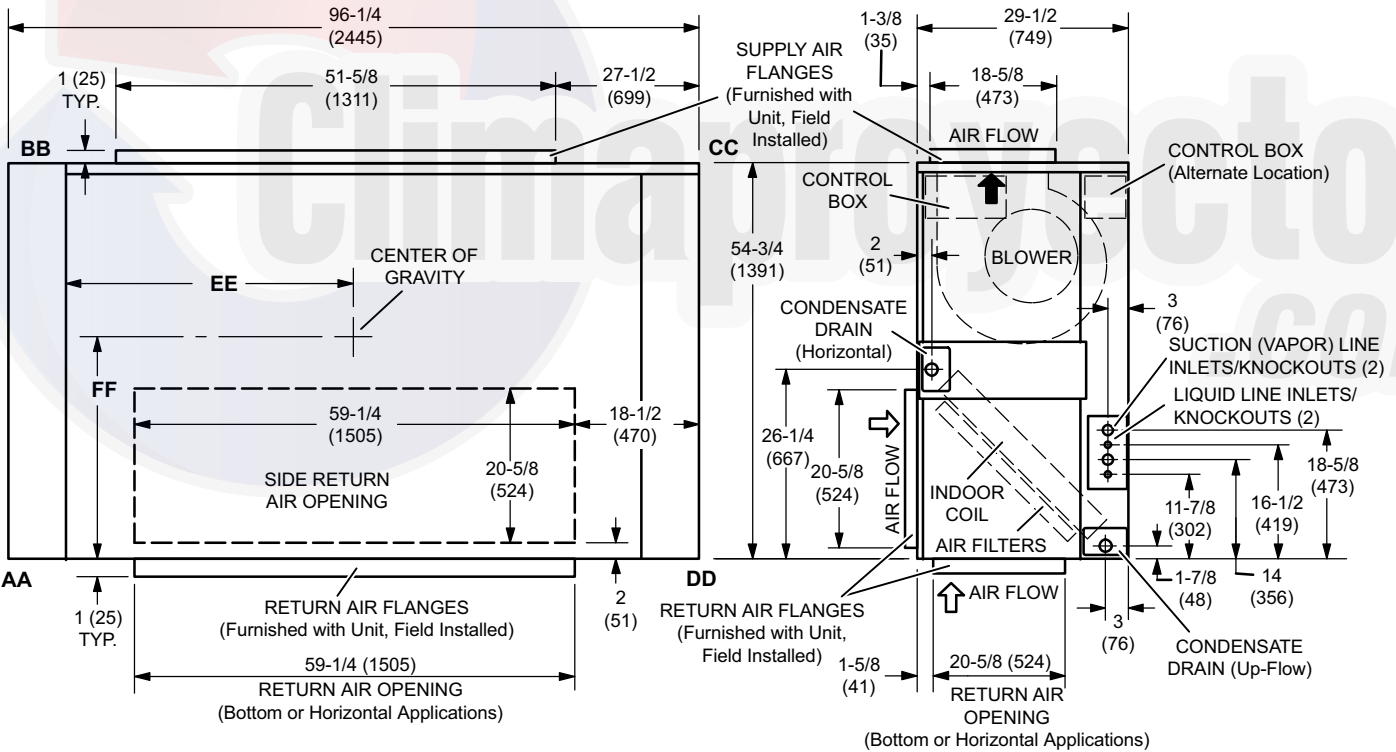

INLET VIEW

DRIVE END VIEW

Unit Parts Arrangement

All TAA Series

HORIZONTAL POSITION SHOWN

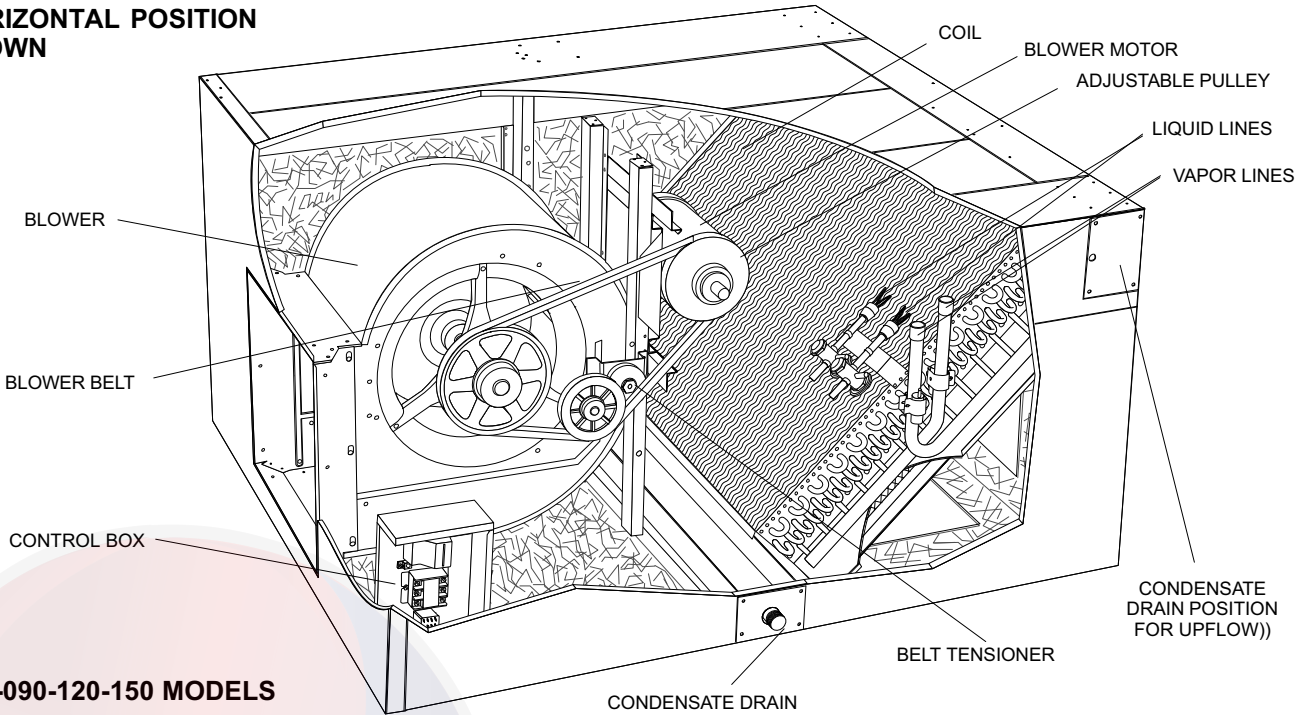

072-090-120-150 MODELS

HORIZONTAL POSITION SHOWN

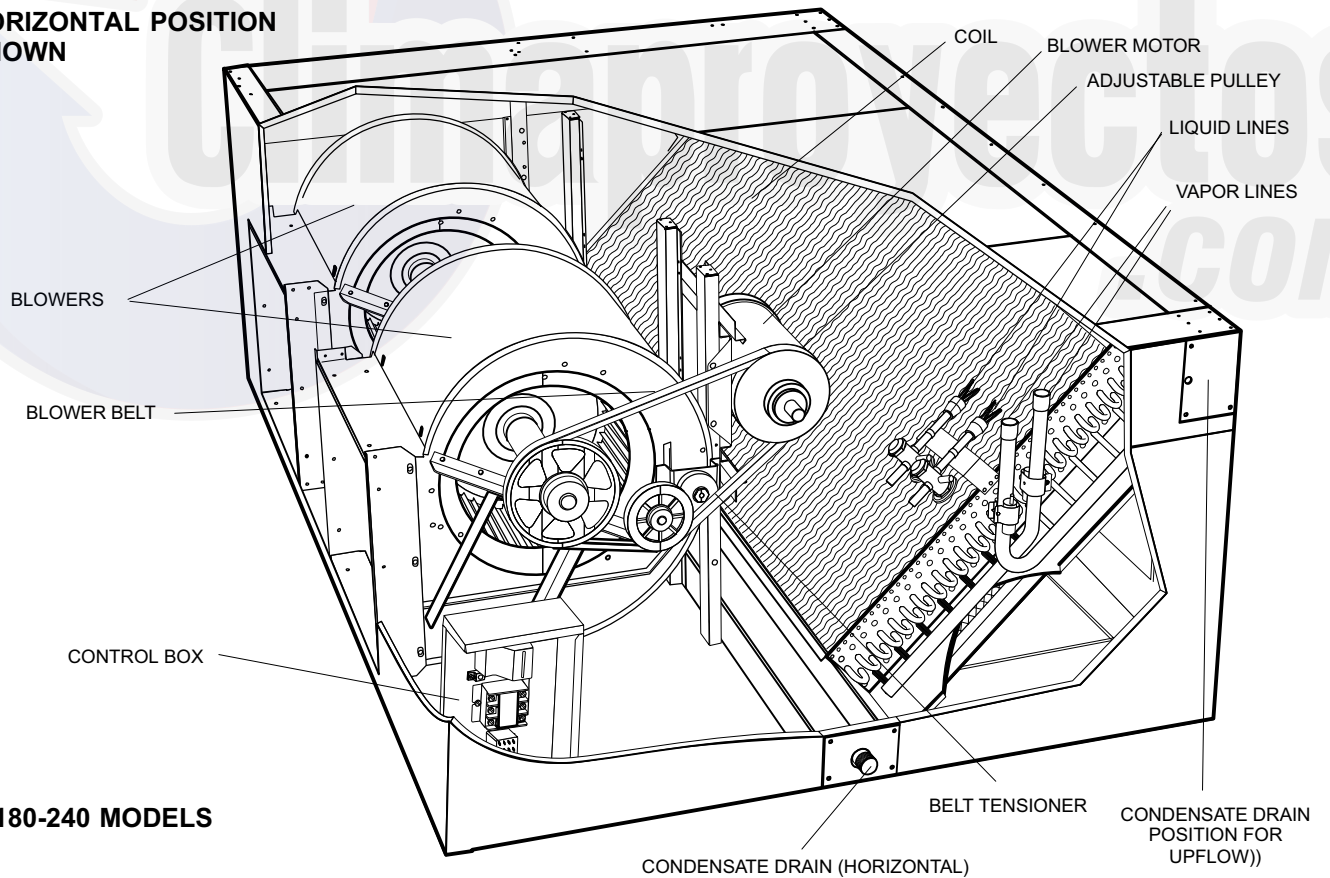

180-240 MODELS

Unit Control Box Components Arrangement

All TAA Series

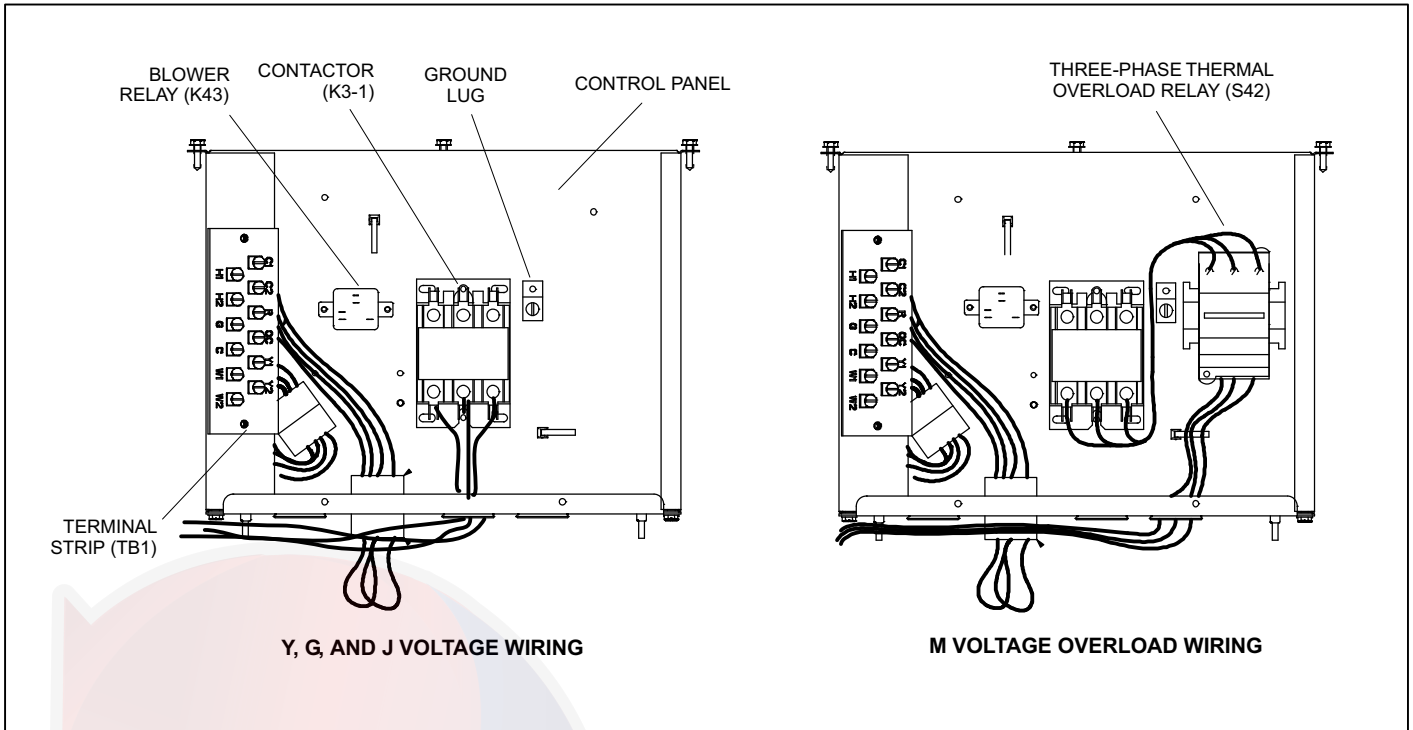

Typical Installation Support Method

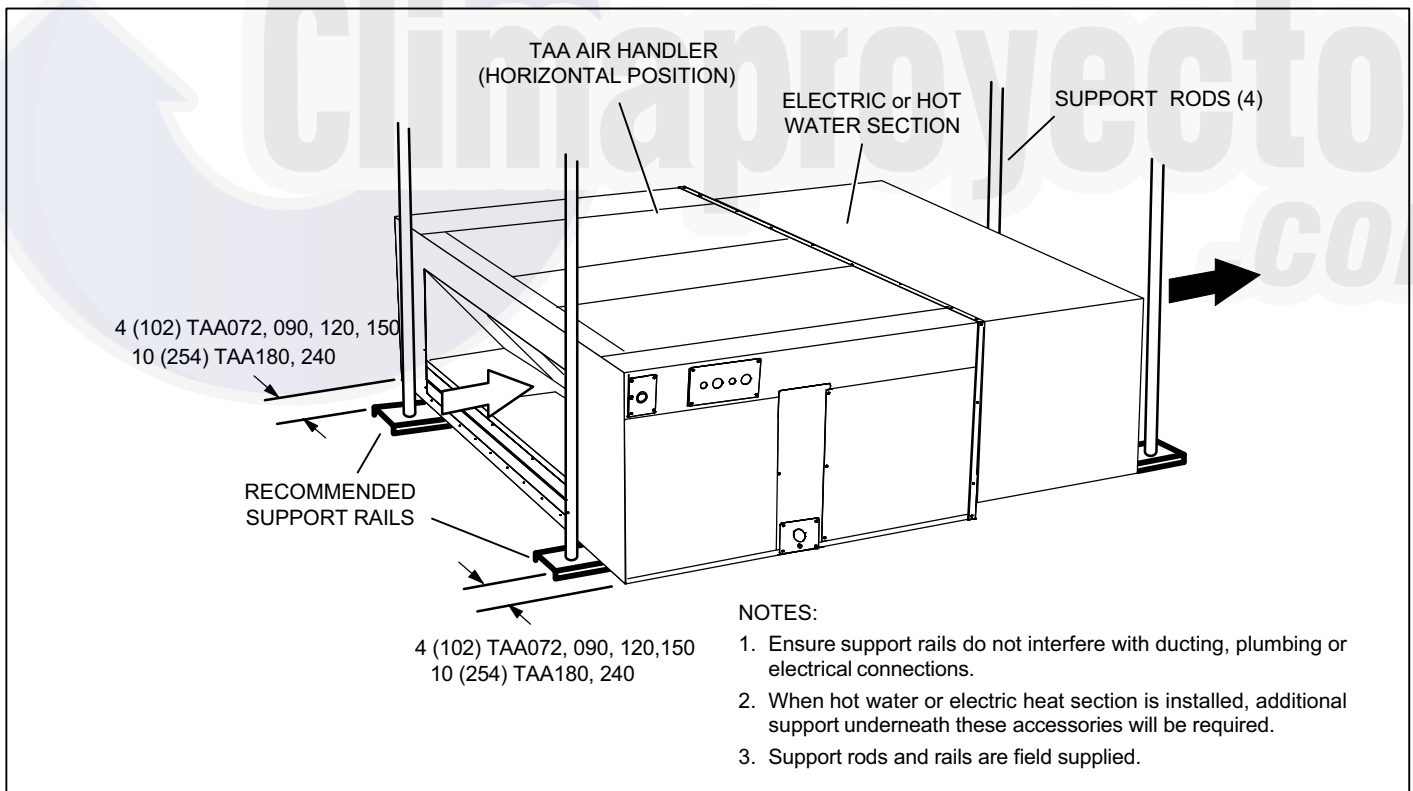

Requirements

These instructions are intended as a general guide and do not supersede local or national codes in any way. Consult authorities having jurisdiction before installation.

In addition to conforming to manufacturer's installation instructions and local municipal building codes, installation of Lennox air handler units (with or without optional electric heat), shall conform with the following National Fire Protection Association (NFPA) standards:

- NFPA No. 90A — Standard for Installation of Air Conditioning and Ventilation Systems
- NFPA No. 90B — Standard for Installation of Residence Type Warm Air Heating and Air Conditioning Systems

This unit is approved for installation clearance to combustible material as stated on the unit rating plate. Accessibility and service clearances must take precedence over combustible material clearances.

Refrigerant Piping Connections

TAA series evaporator coils have a holding charge of nitrogen or dry air. If there is no pressure when the rubber plugs are removed, check the coil for leaks before installing. After installation, pull a vacuum on the coil and line set before releasing the outdoor unit charge into the system.

Table 1. TAA Series Refrigerant Connections Size/Quantity

Models	Liquid Line	Vapor/ Suction Line
-072S4S	5/8" (1)	1-1/8" (1)
-090S4D, -120S4D, and -150S4D	5/8" (2)	7/8" (2)
-180S4D, and -240S4D	5/8" (2)	1-1/8" (2)

For single-stage applications, pipe the upper and lower evaporator circuits together (does not apply to TAA072).

For two-stage applications, pipe the stage 1 system to the lower part of the evaporator and the stage 2 system to the upper part of the evaporator. Table 1 lists piping connection sizes at the evaporator coil. The line set between the TAA air handler and outdoor unit should be sized per the Lennox Refrigerant Piping Guidelines.

4. Route piping through either side of the unit.
5. Remove the knockouts from the piping mullion. Install the rubber grommets into the piping holes.
6. Remove the plugs from the vapor and liquid line stubs.
7. Wrap a wet rag around each TXV before brazing to avoid overheating the valve.
8. Remove protective coil cover between TXVs and evaporator coil as illustrated in figure 1.

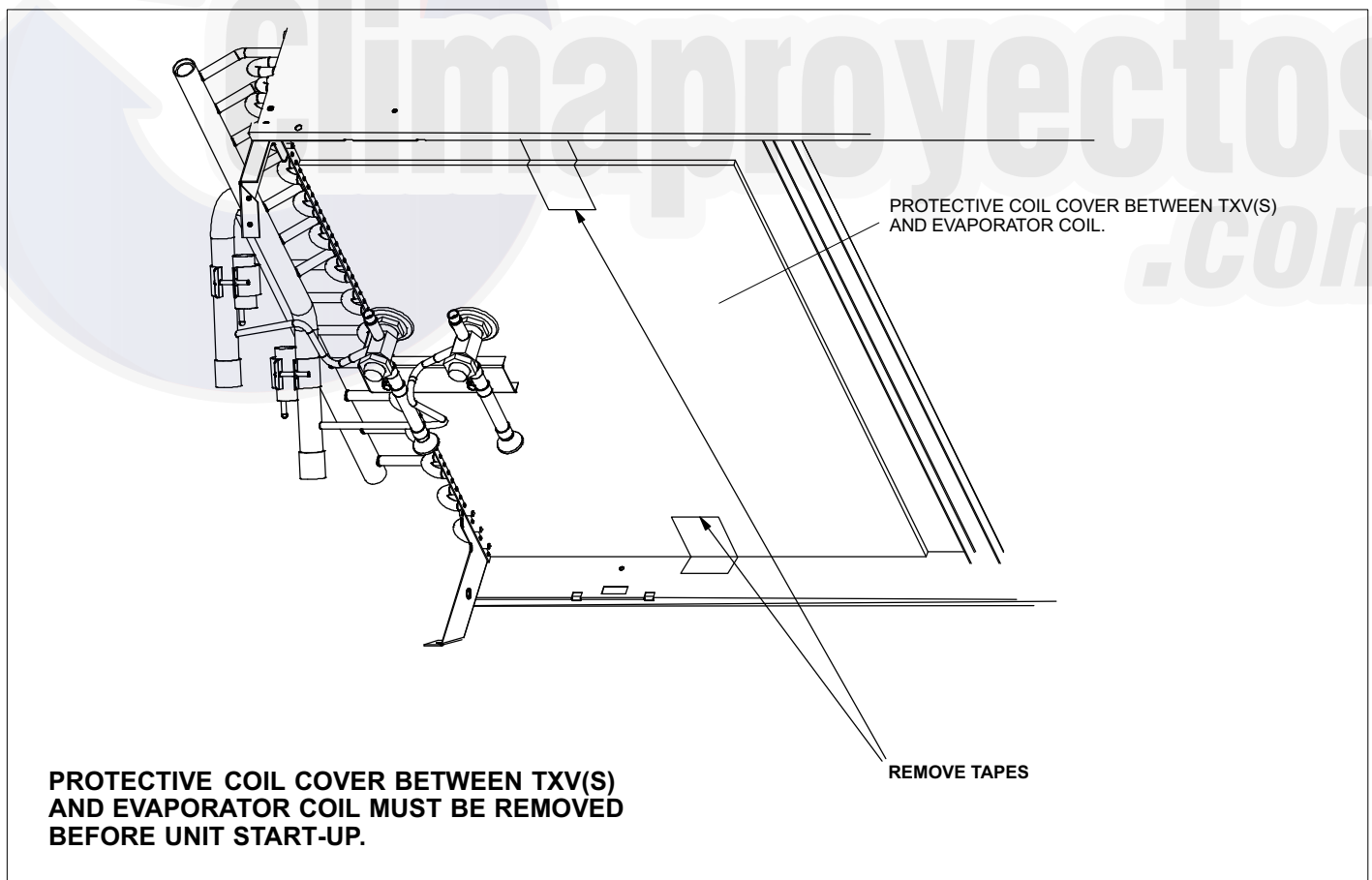

Figure 1. Protective Coil Cover Removal

Installing Condensate Drain

This section provides information concerning drain pan orientation and condensate drain installation.

DRAIN PAN ORIENTATION

This unit has the drain pan shipped in the upflow position. If the unit is installed for horizontal airflow, the drain pan must be repositioned as illustrated in figure 2.

Before connecting drain line, check drain hole to verify that drain opening is fully open and free of any debris. Also

check to make sure that no debris has fallen into the drain pan during installation that may plug up the drain opening.

CONDENSATE DRAIN INSTALLATION

Connect main condensate drain (one inch N.P.T.) and route downward to an open drain or sump. The drain pan is made with a glass reinforced engineered plastic capable of withstanding typical joint torque but can be damaged with excessive force. Tighten pipe nipple hand tight and turn an additional quarter turn. Do not connect drain to a closed waste system. See figure 3 for typical condensate trap configuration.

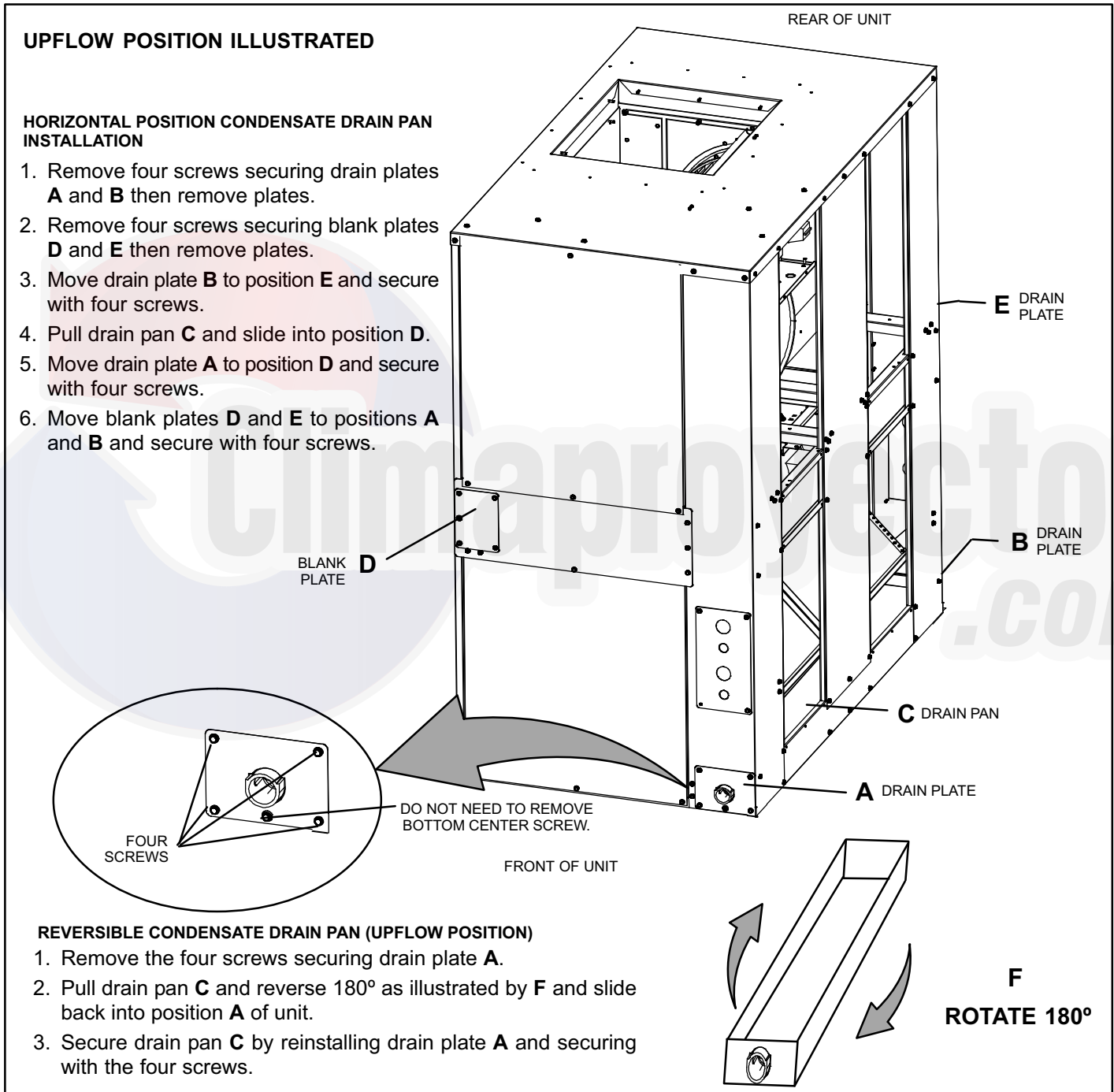

Figure 2. Condensate Drain Configurations

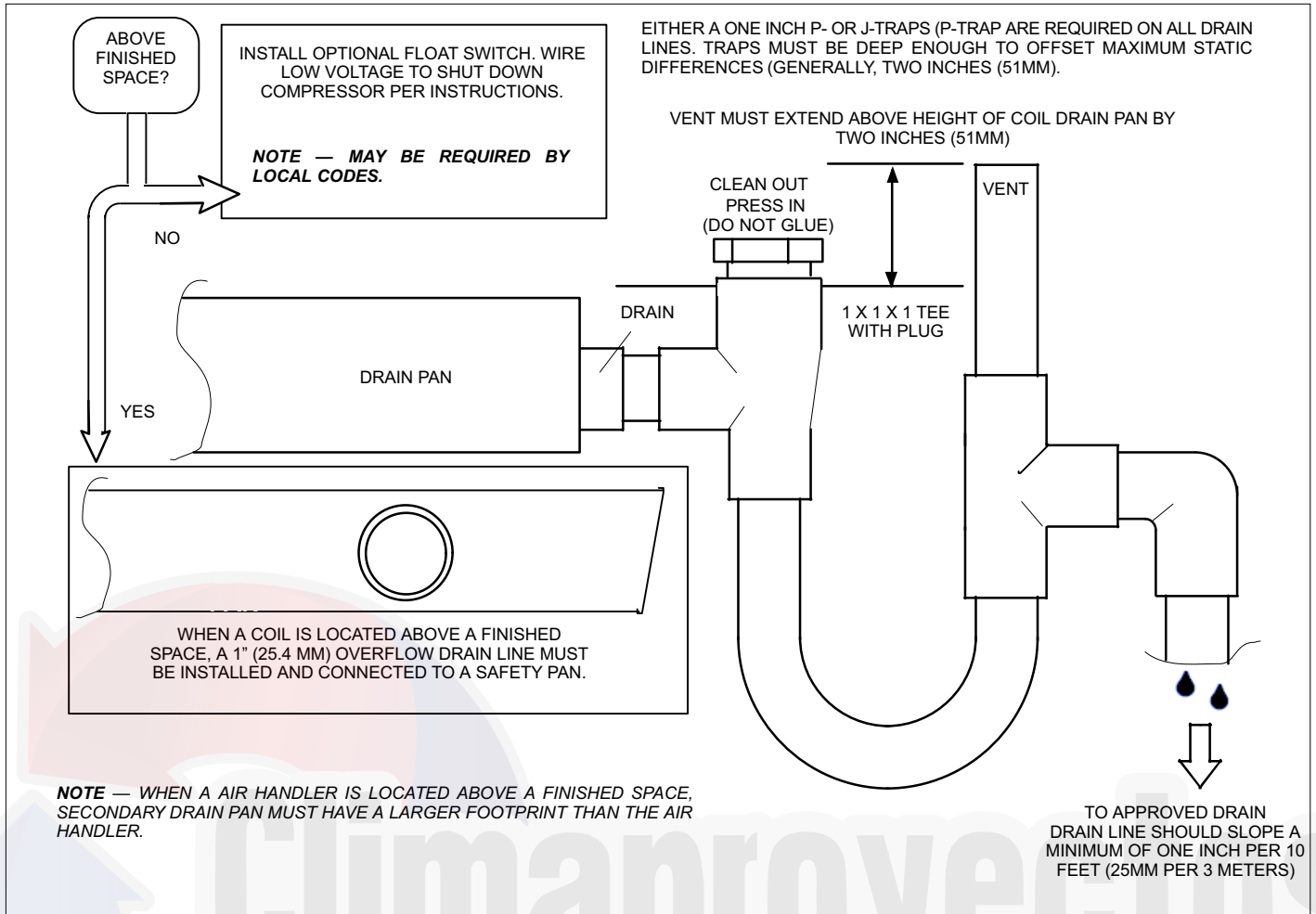

Figure 3. Typical Condensate Drain Connections

Table 2. TAA Duct Flange Lengths - inches (mm)

Models	TAA072/090	TAA120/150	TAA180/240
Return air flanges — Common (2)	20-1/2" (521)	20-1/2" (521)	20-1/2" (521)
Return air flanges — Long (2)	30" (762)	45" (1143)	59-3/8" (1508)
Discharge air flanges — Common (2)	18-1/2" (470)	18-1/2" (470)	18-1/2" (470)
Discharge air flanges — Long (2)	25-5/8" (651)	25-5/8" (651)	51-3/8" (1305)

Duct Connections

SIDE RETURN AIR COVER PLATE RELOCATION

UNIT IS SHIPPED FOR INSTALLATION IN AN UPFLOW OR HORIZONTAL APPLICATION WITH BOTTOM (OR END) RETURN AIR. IF UNIT WILL BE USED IN AN UPFLOW APPLICATION WITH SIDE RETURN AIR, REMOVE SCREWS THAT SECURE SIDE COVER PLATE ON SIDE RETURN AIR OPENING. USE EXISTING SCREWS TO RE-SECURE COVER PLATE OVER BOTTOM OPENING.

072-090-120-150 MODELS

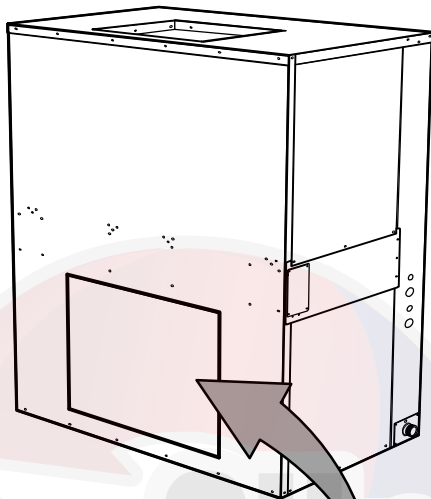

SIDE VIEW

SIDE RETURN AIR COVER PLATE (SHIPPED FROM FACTORY INSTALLED)

NOTE — SIDE RETURN AIR COVER PLATE CAN BE RELOCATED TO BOTTOM RETURN AIR LOCATION.

IF A RETURN AIR PLENUM IS NOT USED, INSTALLATION CODES MAY LIMIT INSTALLATION TO SINGLE-STORY STRUCTURES ONLY. DO NOT INSTALL THE SUPPLY AIR PLENUM WITHIN 18 INCHES (457 MM) OF THE BLOWER ACCESS PANEL.

NOTE — Use flexible duct to eliminate vibration.

INSTALLATION OF FLANGES

ALIGN PROVIDED FLANGES WITH PRE-DRILLED HOLES IN BOTH RETURN AND SUPPLY AIR LOCATIONS AND SECURE WITH FIELD-PROVIDED SHEET METAL SCREWS (#10-16 X 5/8").

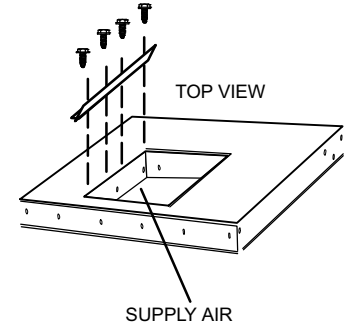

TOP VIEW

SUPPLY AIR

180-240 MODELS

NOTE — ON DUAL-BLOWER UNITS, FLANGES ENCOMPASS BOTH OPENINGS.

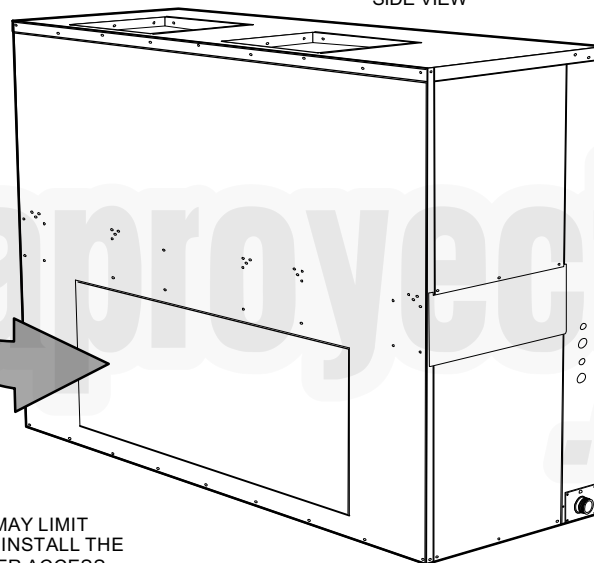

SIDE VIEW

Figure 4. Cover Plate Relocation and Installation of Flanges

Sealing the Unit

Seal the unit so that warm air is not allowed into the cabinet. Warm air introduces moisture, which results in water blow-off problems. This is especially important when the unit is installed in an unconditioned area.

⚠ WARNING

There must be an airtight seal between the bottom of the air handler and the return air plenum. Use fiberglass sealing strips, caulking, or equivalent sealing method between the plenum and the air handler cabinet to ensure a tight seal. Return air must not be drawn from a room where any gas-fueled appliance (i.e., water heater), or carbon monoxide-producing device (i.e., wood fireplace) is installed.

Wiring

⚠ WARNING

Run 24V Class II wiring only through specified low voltage opening. Run line voltage wiring only through specified high voltage opening. Do not combine voltage in one opening.

NATIONAL AND LOCAL CODE RESTRICTIONS

Wiring must conform to the current National Electric Code ANSI/NFPA No. 70, or Canadian Electric Code Part I, CSA Standard C22.1, and local building codes. Refer to following wiring diagrams. See unit nameplate for minimum circuit ampacity and maximum over-current protection size.

Select the proper supply circuit conductors in accordance with tables 310-16 and 310-17 in the National Electric Code, ANSI/NFPA No. 70 or tables 1 through 4 in the Canadian Electric Code, Part I, CSA Standard C22.1.

Separate openings have been provided for 24V low voltage and line voltage. Refer to the dimension illustration of specific location.

WIRING DIAGRAMS

Two wiring diagrams are included in the bag assembly and are for the following:

- Unit wiring diagram
- Thermostat connections

Both diagrams are to be installed on outside cabinet in a convenient location

⚠ CAUTION

USE COPPER CONDUCTORS ONLY.

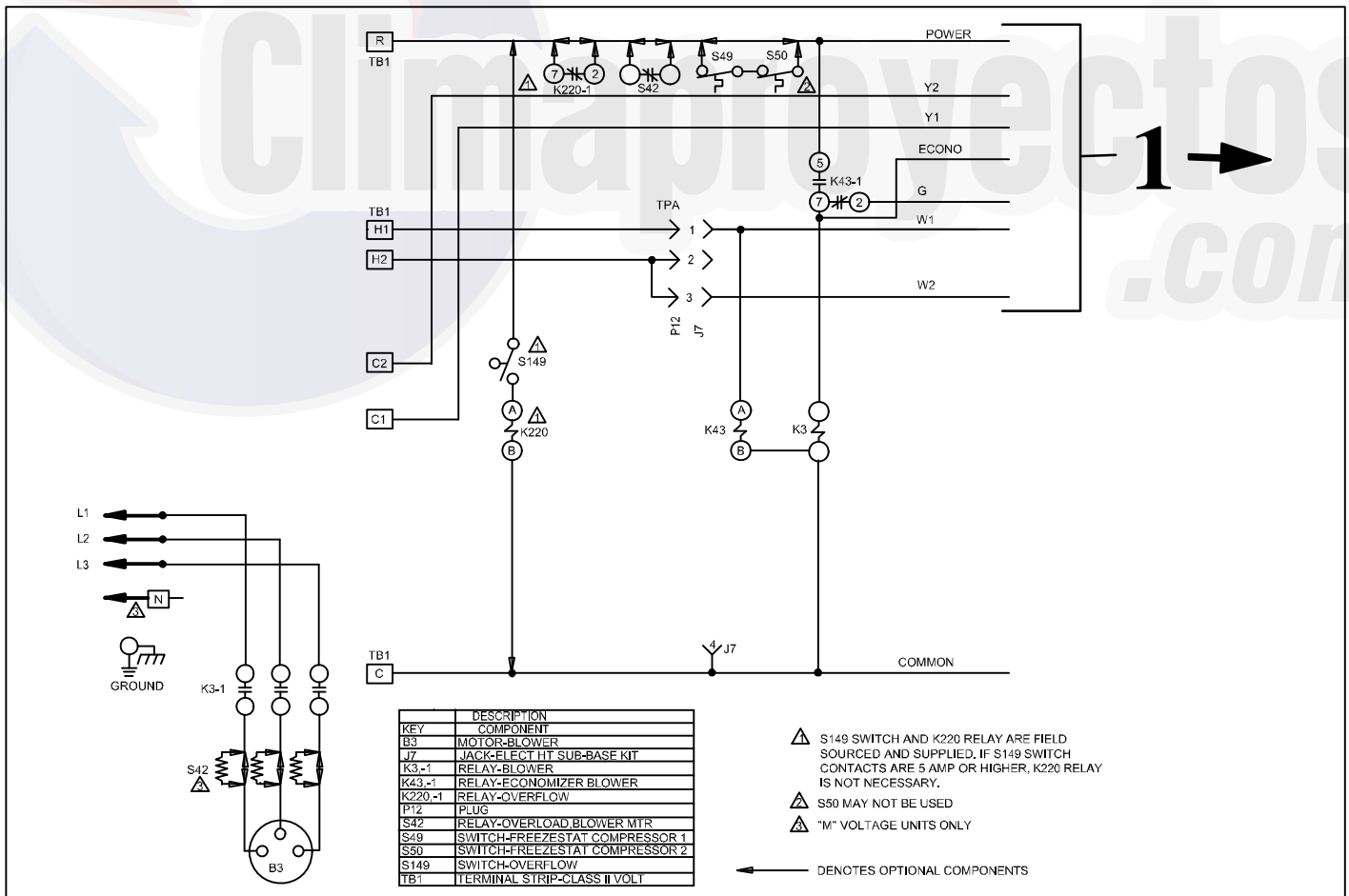

Figure 5. Typical Wiring Diagram

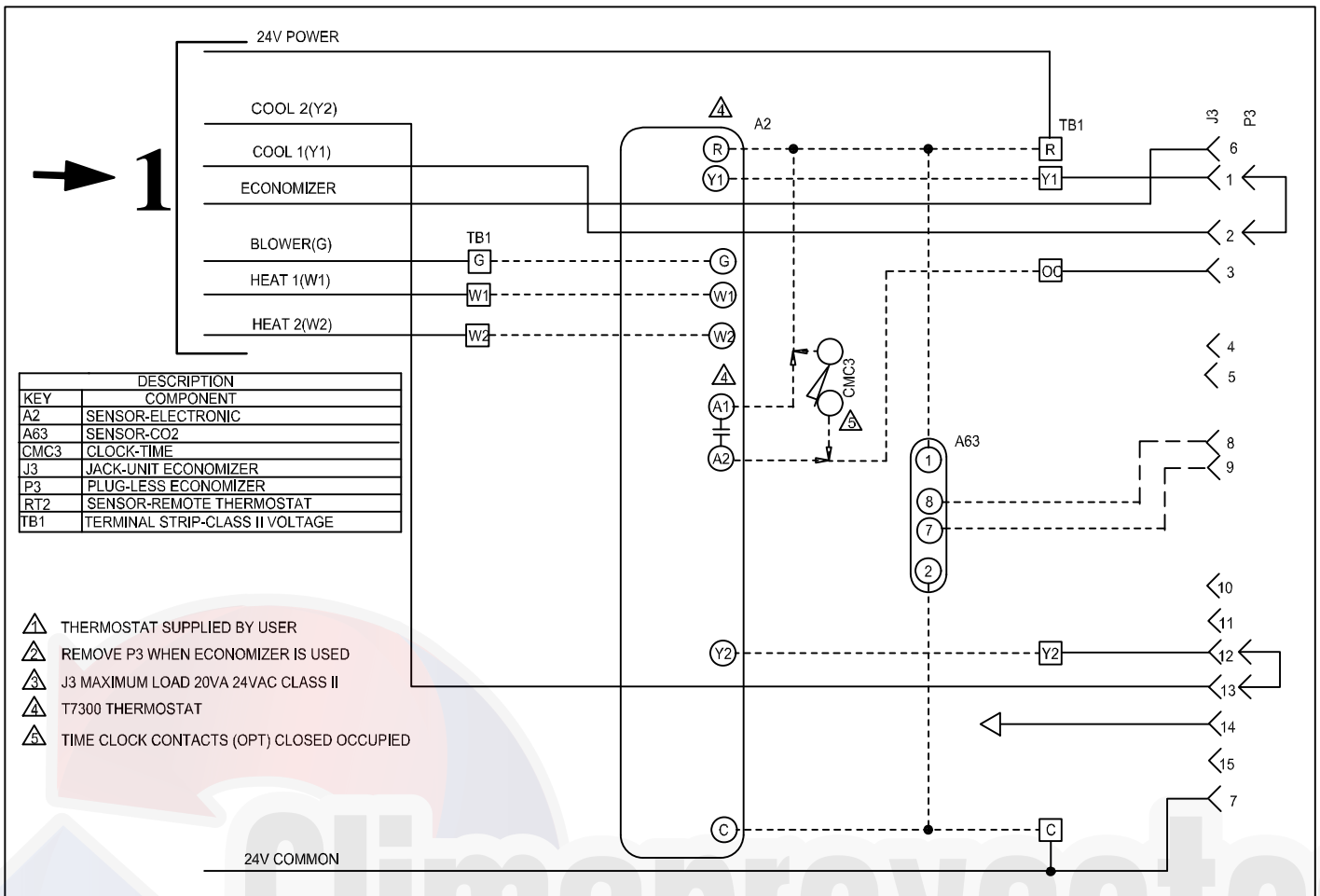

Figure 6. Typical Control Wiring used with TSA and TPA Outdoor Units.

Blower Motor Belt Tensioning Adjustment

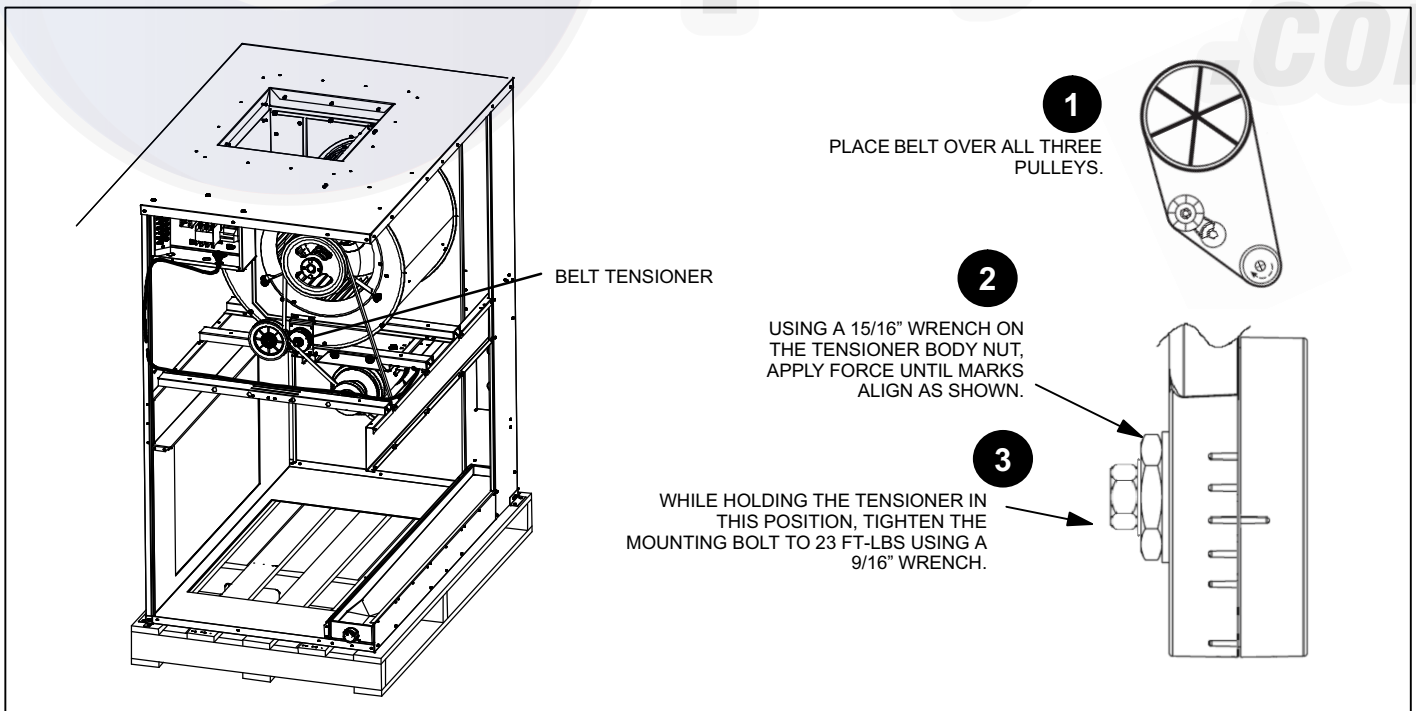

Figure 7. Typical Blower Belt Tensioner Adjustment Procedure

Pulley Alignment

AFTER ANY PULLEY ADJUSTMENT OR CHANGE OUT, PULLEYS SHOULD BE ALIGNED WITH THE TENSIONER AS SHOWN.

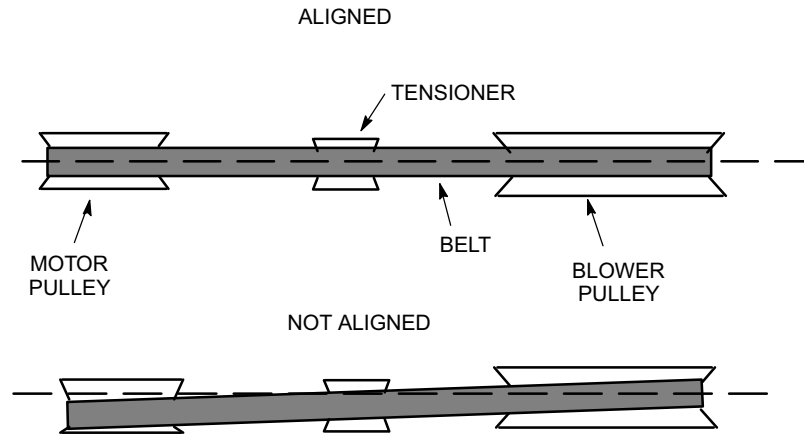

Figure 8. Typical Pulley Alignment

Air Volume Adjustment

The diagram shows a cutaway view of an HVAC unit's blower compartment. It highlights the motor, a fixed pulley, a blower belt, and an adjustable pulley. A detailed inset shows the adjustable pulley with an Allen screw used for adjustment.

- 1 RUN THE BLOWER WITHOUT A COOLING DEMAND.
- 2 MEASURE THE STATIC PRESSURE EXTERNAL TO THE UNIT.
- 3 MEASURE THE INDOOR BLOWER MOTOR'S RPM.
- 4 USE THE STATIC PRESSURE AND REV/MIN READINGS TO DETERMINE THE UNIT'S AIR VOLUME (SEE APPLICABLE BLOWER PERFORMANCE TABLES).
- 5 LOOSEN THE ALLEN SCREW ON THE ADJUSTABLE PULLEY.
- 6 TURN THE ADJUSTABLE SHEAVE CLOCKWISE TO INCREASE THE AIR VOLUME OR COUNTERCLOCKWISE TO DECREASE THE AIR VOLUME.
- 7 ONCE THE DESIRED AIR VOLUME HAS BEEN ACHIEVED, TIGHTEN THE ALLEN SCREW.

NOTE — THE INDOOR COIL MUST BE DRY AND THE AIR FILTERS MUST BE IN PLACE WHEN THE FOLLOWING MEASUREMENTS ARE TAKEN.

Figure 9. Typical Air Volume Adjustment Procedure

Blower Data

BLOWER DRIVE SPECIFICATIONS (60Hz)

Static	RPM Range	Motor HP		072	090	120	150	180	240
		Nominal	Maximum						
Low	552 - 782	1.5	1.72	○	---	---	---	---	---
Standard	690 - 936	1.5	1.72	S	---	---	---	---	---
High	906 - 1121	2	2.3	○	---	---	---	---	---
Low	644 - 874	2	2.3	---	○	---	---	---	---
Standard	782 - 1012	2	2.3	---	S	---	---	---	---
High	966 - 1196	3	3.45	---	○	---	---	---	---
Low	690 - 893	2	2.3	---	---	○	---	---	---
Standard	852 - 1055	2	2.3	---	---	S	---	---	---
High	986 - 1232	3	3.45	---	---	○	---	---	---
Low	782 - 1012	3	3.45	---	---	---	○	---	---
Standard	920 - 1150	3	3.45	---	---	---	S	---	---
High	1134 - 1380	5	5.75	---	---	---	○	---	---
Low	591 - 838	3	3.45	---	---	---	---	○	---
Standard	782 - 1012	5	5.75	---	---	---	---	S	---
High	920 - 1150	5	5.75	---	---	---	---	○	---
Low	679 - 863	5	5.75	---	---	---	---	---	○
Standard	808 - 1026	7.5	8.63	---	---	---	---	---	S
High	1002 - 1282	7.5	8.63	---	---	---	---	---	○

NOTE - Using total air volume and system static pressure requirements, determine from blower performance tables rpm and motor horsepower required. Maximum usable horsepower of motors furnished by Lennox are shown. In Canada, nominal motor horsepower is also maximum usable motor horsepower. If motors of comparable horsepower are used, be sure to keep within the service factor limitations outlined on the motor nameplate.

S - Factory installed standard

○ - Factory Installed with extended lead time.

BLOWER DRIVE SPECIFICATIONS (50Hz)

Static	Rev/min Range	Drive Kit	Motor kW		Motor HP		072	090	120	150	180	240
			Nominal	Maximum	Nominal	Maximum						
Low	541 - 735	4	1.5	1.7	2	2.3	○	---	---	---	---	---
Standard	704 - 911	18	1.5	1.7	2	2.3	S	---	---	---	---	---
High	889 - 1083	19	1.5	1.7	2	2.3	○	---	---	---	---	---
Low	616 - 798	20	1.5	1.7	2	2.3	---	○	---	---	---	---
Standard	773 - 967	10	1.5	1.7	2	2.3	---	S	---	---	---	---
High	953 - 1160	11	2.2	2.6	3	3.45	---	○	---	---	---	---
Low	657 - 851	5	1.5	1.7	2	2.3	---	---	○	---	---	---
Standard	812 - 1005	21	1.5	1.7	2	2.3	---	---	S	---	---	---
High	996 - 1212	22	2.2	2.6	3	3.45	---	---	○	---	---	---
Low	785 - 955	23	2.2	2.6	3	3.45	---	---	---	○	---	---
Standard	953 - 1160	11	2.2	2.6	3	3.45	---	---	---	S	---	---
High	1125 - 1342	24	3.5	4.3	5	5.75	---	---	---	○	---	---
Low	616 - 798	25	2.2	2.6	3	3.45	---	---	---	---	○	---
Standard	773 - 967	26	3.5	4.3	5	5.75	---	---	---	---	S	---
High	953 - 1160	27	3.5	4.0	5	5.75	---	---	---	---	○	---
Low	679 - 863	14	3.5	4.0	5	5.75	---	---	---	---	---	○
Standard	843 - 1078	17	5.6	6.4	7.5	8.62	---	---	---	---	---	S
High	1078 - 1274	28	5.6	6.4	7.5	8.62	---	---	---	---	---	○

NOTE - Using total air volume and system static pressure requirements, determine from blower performance tables Rev/min and motor horsepower required.

Maximum usable horsepower of motors furnished by Lennox are shown. If motors of comparable horsepower are used, be sure to keep within the service factor limitations outlined on the motor nameplate.

S - Factory installed standard

○ - Factory Installed with extended lead time.

Blower Drive Components

BLOWER DRIVE COMPONENTS, 60 HZ

Unit	Static	Adjustable Sheave		Fixed Sheave		Belt		Bushing		Key	
		OEM No	Manuf No	OEM No	Manuf No	OEM No	Manuf No	OEM No	Manuf No	OEM No	Dimensions
TAA072	Low	79J0301	1VP40 X 7/8	49K4101	BK85 X 1	100245-25	AX54	-	-	-	-
	Standard	P-8-1488	1VP44 X 7/8	100788-03	BK80H	100245-24	AX53	100073-04	H-1	LB-21259	1/4 X 1/4 X1-1/2
	High	80K5501	1VP60 X 7/8	P-8-9659	BK90 X 1	100245-28	AX57	-	-	LB-21259	1/4 X 1/4 X1-1/2
TAA090	Low	P-8-1488	1VP44 X 7/8	49K4101	BK85 X 1	100245-25	AX54	-	-	-	-
	Standard	P-8-2187	1VP50 X 7/8	49K4101	BK85 X 1	100245-26	AX55	-	-	-	-
	High	80K5501	1VP60 X 7/8	49K4101	BK85 X 1	100245-28	AX57	-	-	-	-
TAA120	Low	P-8-2187	1VP50 X 7/8	79J2701	BK95 X 1	100245-28	AX57	-	-	-	-
	Standard	80K5501	1VP60 X 7/8	79J2701	BK95 X 1	100245-28	AX57	-	-	-	-
	High	P-8-1494	1VP56 X 7/8	100788-03	BK80H	100245-25	AX54	100073-04	H-1	LB-21259	1/4 X 1/4 X1-1/2
TAA150	Low	P-8-2187	1VP50 X 7/8	49K4101	BK85 X 1	100245-26	AX55	-	-	-	-
	Standard	P-8-1494	1VP56 X 7/8	49K4101	BK85 X 1	100245-26	AX55	-	-	-	-
	High	P-8-2237	1VP62 X 1-1/8	100788-03	BK80H	100245-27	AX56	100073-04	H-1	LB-21259	1/4 X 1/4 X1-1/2
TAA180	Low	79J0301	1VP40 X 7/8	100788-03	BK80H	49K3901	BX54	49M6201	H-1-7/16	LB-21259	1/4 X 1/4 X1-1/2
	Standard	P-8-1977	1VP50 X 1-1/8	100244-09	BK85 X 1-7/16	78L5301	BX57	-	-	LB-20769	3/8 X 3/8 X 1-3/4
	High	100239-01	1VP56 X 1-1/8	100244-09	BK85 X 1-7/16	100245-07	BX58	-	-	LB-20769	3/8 X 3/8 X 1-3/4
TAA240	Low	P-8-1977	1VP50 X 1-1/8	39L1301	BK100 X 1-7/16	100245-10	BX60	-	-	LB-20769	3/8 X 3/8 X 1-3/4
	Standard	78L5501	1VP60 X 1-3/8	100788-05	BK100H	93J9801	BX61	49M6201	H-1-7/16	-	-
	High	78L5501	1VP60 X 1-3/8	100788-03	BK80H	100245-07	BX58	49M6201	H-1-7/16	-	-

BLOWER DRIVE COMPONENTS, 50 HZ

Unit	Static	Adjustable Sheave		Fixed Sheave		Belt		Bushing		Key	
		OEM No	Manuf No	OEM No	Manuf No	OEM No	Manuf No	OEM No	Manuf No	OEM No	Manuf No
TAA072	Low	P-8-1488	1VP44 X 7/8	49K4101	BK85 X 1	100245-25	AX54	-	-	-	-
	Standard	P-8-2187	1VP50 X 7/8	100788-03	BK80H	100245-25	AX54	100073-04	H-1	LB-21259	1/4 X 1/4 X1-1/2
	High	P-8-1491	1VP62 X 7/8	49K4101	BK85 X 1	93J9801	BX61	-	-	-	-
TAA090	Low	P-8-2187	1VP50 X 7/8	P-8-9659	BK90 X 1	100245-27	AX56	-	-	-	-
	Standard	P-8-1494	1VP56 X 7/8	49K4101	BK85 X 1	100245-26	AX55	-	-	-	-
	High	P-8-2237	1VP62 X 1-1/8	100788-03	BK80H	100245-27	AX56	100073-04	H-1	LB-21259	1/4 X 1/4 X1-1/2
TAA120	Low	P-8-2187	1VP50 X 7/8	49K4101	BK85 X 1	100245-26	AX55	-	-	-	-
	Standard	80K5501	1VP60 X 7/8	49K4101	BK85 X 1	100245-27	AX56	-	-	-	-
	High	P-8-2237	1VP62 X 1-1/8	49K4101	BK85 X 1	100245-26	AX55	-	-	LB-21259	1/4 X 1/4 X1-1/2
TAA150	Low	P-8-2237	1VP62 X 1-1/8	79J2701	BK95 X 1	100245-28	AX57	-	-	LB-21259	1/4 X 1/4 X1-1/2
	Standard	P-8-2237	1VP62 X 1-1/8	100788-03	BK80H	100245-27	AX56	100073-04	H-1	LB-21259	1/4 X 1/4 X1-1/2
	High	P-8-1493	1VP68 X 1-1/8	49K4001	BK77 X 1	100245-27	AX56	-	-	LB-21259	1/4 X 1/4 X1-1/2
TAA180	Low	P-8-1977	1VP50 X 1-1/8	100788-04	BK90H	100245-07	BX58	49M6201	H-1-7/16	-	-
	Standard	P-8-1492	1VP56 X 1-1/8	100244-09	BK85 X 1-7/16	100245-07	BX58	-	-	LB-20769	3/8 X 3/8 X 1-3/4
	High	P-8-2237	1VP62 X 1-1/8	100788-03	BK80H	100245-07	BX58	49M6201	H-1-7/16	-	-
TAA240	Low	P-8-1977	1VP50 X 1-1/8	100244-09	BK85 X 1-7/16	78L5301	BX57	-	-	LB-20769	3/8 X 3/8 X 1-3/4
	Standard	78L5501	1VP60 X 1-3/8	100788-03	BK80H	100245-07	BX58	49M6201	H-1-7/16	-	-
	High	100239-04	1VP68 X 1-3/8	100788-03	BK80H	59A5001	BX59	49M6201	H-1-7/16	-	-

Blower Performance

TA 072 BLOWER PERFORMANCE

Air Volume cfm	STATIC PRESSURE EXTERNAL TO UNIT — Inches Water Gauge															
	0.1		0.2		0.3		0.4		0.5		0.6		0.7		0.8	
	RPM	BHP	RPM	BHP	RPM	BHP	RPM	BHP	RPM	BHP	RPM	BHP	RPM	BHP	RPM	BHP
1900	428	0.57	479	0.66	531	0.74	581	0.81	629	0.88	675	0.94	718	1.01	758	1.07
2000	434	0.59	486	0.69	538	0.77	589	0.84	637	0.91	682	0.98	725	1.05	765	1.11
2100	441	0.62	493	0.72	545	0.8	596	0.88	644	0.95	689	1.02	732	1.09	771	1.15
2200	448	0.65	501	0.75	553	0.83	604	0.91	652	0.98	696	1.06	738	1.13	778	1.2
2300	456	0.68	508	0.78	561	0.86	612	0.94	659	1.02	704	1.1	746	1.17	785	1.24
2400	463	0.71	516	0.81	569	0.9	620	0.98	667	1.06	711	1.14	753	1.22	792	1.29
2500	470	0.74	524	0.84	578	0.94	629	1.02	675	1.1	719	1.19	760	1.27	798	1.34
2600	478	0.77	533	0.88	587	0.98	637	1.06	683	1.15	726	1.24	767	1.32	805	1.39
2700	486	0.81	542	0.92	596	1.02	646	1.11	692	1.2	734	1.29	775	1.37	812	1.45
2800	495	0.85	552	0.96	606	1.07	655	1.16	700	1.25	742	1.34	782	1.42	819	1.5
2900	504	0.89	561	1.01	616	1.11	665	1.2	708	1.3	750	1.39	789	1.48	826	1.56
3000	514	0.93	572	1.05	626	1.16	674	1.26	717	1.35	758	1.45	797	1.54	833	1.62

Air Volume cfm	STATIC PRESSURE EXTERNAL TO UNIT — Inches Water Gauge													
	0.9		1		1.1		1.2		1.3		1.4		1.5	
	RPM	BHP	RPM	BHP	RPM	BHP	RPM	BHP	RPM	BHP	RPM	BHP	RPM	BHP
1900	796	1.13	830	1.19	862	1.25	893	1.32	922	1.39	950	1.46	978	1.54
2000	802	1.17	836	1.23	868	1.3	898	1.37	928	1.44	956	1.52	983	1.6
2100	808	1.22	842	1.28	874	1.35	904	1.42	933	1.5	961	1.58	988	1.66
2200	814	1.26	848	1.33	879	1.4	909	1.48	938	1.56	966	1.64	993	1.73
2300	820	1.31	854	1.38	885	1.46	915	1.53	943	1.62	971	1.7	998	1.79
2400	827	1.36	860	1.43	891	1.51	920	1.59	949	1.68	976	1.77	1003	1.86
2500	833	1.41	866	1.49	897	1.57	926	1.66	954	1.75	981	1.84	1008	1.93
2600	840	1.47	872	1.55	902	1.63	932	1.72	960	1.81	987	1.91	1013	2.01
2700	846	1.53	878	1.61	908	1.7	937	1.79	965	1.88	992	1.98	1018	2.08
2800	853	1.58	884	1.67	914	1.76	943	1.86	970	1.96	997	2.06	1023	2.16
2900	859	1.65	890	1.74	920	1.83	948	1.93	975	2.03	1002	2.14	1028	2.24
3000	866	1.71	896	1.8	926	1.9	954	2	981	2.11	1007	2.22	1032	2.33

TA 090 BLOWER PERFORMANCE

Air Volume cfm	STATIC PRESSURE EXTERNAL TO UNIT — Inches Water Gauge															
	0.1		0.2		0.3		0.4		0.5		0.6		0.7		0.8	
	RPM	BHP	RPM	BHP	RPM	BHP	RPM	BHP	RPM	BHP	RPM	BHP	RPM	BHP	RPM	BHP
2400	508	0.79	565	0.89	619	0.98	667	1.06	710	1.14	750	1.23	787	1.3	822	1.38
2500	519	0.83	577	0.94	630	1.02	677	1.1	720	1.19	759	1.28	796	1.36	830	1.43
2600	531	0.87	588	0.98	641	1.07	688	1.16	729	1.25	769	1.34	805	1.42	839	1.49
2700	543	0.92	600	1.03	653	1.12	698	1.21	739	1.31	778	1.4	814	1.48	848	1.55
2800	555	0.97	613	1.08	664	1.17	709	1.27	749	1.37	788	1.46	824	1.54	857	1.62
2900	568	1.02	625	1.13	676	1.22	719	1.32	759	1.43	797	1.52	833	1.6	866	1.68
3000	581	1.07	638	1.18	687	1.28	730	1.39	769	1.49	807	1.58	842	1.67	875	1.75
3100	595	1.12	651	1.24	699	1.34	740	1.45	779	1.56	817	1.65	852	1.73	883	1.82
3200	609	1.18	664	1.3	710	1.41	751	1.52	789	1.63	827	1.72	861	1.8	892	1.89
3300	624	1.24	677	1.36	722	1.48	761	1.59	799	1.7	836	1.79	870	1.88	901	1.97
3400	639	1.3	690	1.43	733	1.55	772	1.67	810	1.77	846	1.86	879	1.95	909	2.05
3500	653	1.37	703	1.5	745	1.62	782	1.75	820	1.85	856	1.94	888	2.03	917	2.14
3600	668	1.44	715	1.57	756	1.7	793	1.83	830	1.93	865	2.02	897	2.12	925	2.24

Air Volume cfm	STATIC PRESSURE EXTERNAL TO UNIT — Inches Water Gauge													
	0.9		1		1.1		1.2		1.3		1.4		1.5	
	RPM	BHP	RPM	BHP	RPM	BHP	RPM	BHP	RPM	BHP	RPM	BHP	RPM	BHP
2400	855	1.44	888	1.51	920	1.59	950	1.67	979	1.77	1006	1.86	1033	1.96
2500	863	1.5	896	1.57	928	1.65	958	1.74	986	1.84	1013	1.94	1039	2.04
2600	872	1.56	904	1.64	936	1.72	965	1.82	993	1.92	1019	2.02	1045	2.12
2700	880	1.62	913	1.7	943	1.79	972	1.89	1000	2	1026	2.1	1052	2.2
2800	889	1.69	921	1.77	951	1.87	979	1.97	1006	2.08	1033	2.18	1058	2.29
2900	898	1.76	929	1.85	959	1.95	987	2.05	1013	2.16	1039	2.26	1064	2.37
3000	906	1.83	937	1.93	966	2.03	994	2.13	1020	2.24	1046	2.35	1070	2.46
3100	914	1.91	944	2.01	973	2.11	1001	2.22	1027	2.33	1052	2.44	1077	2.55
3200	922	1.99	952	2.09	980	2.2	1008	2.3	1033	2.41	1058	2.53	1083	2.64
3300	930	2.07	959	2.18	987	2.29	1014	2.39	1040	2.5	1065	2.62	1089	2.73
3400	938	2.16	966	2.27	994	2.38	1021	2.49	1046	2.6	1071	2.71	1095	2.83
3500	945	2.26	973	2.37	1001	2.48	1028	2.58	1053	2.69	1077	2.81	1101	2.93
3600	953	2.35	980	2.47	1008	2.58	1034	2.68	1059	2.79	1084	2.91	1107	3.03

TA 120 BLOWER PERFORMANCE

Air Volume cfm	STATIC PRESSURE EXTERNAL TO UNIT — Inches Water Gauge															
	0.1		0.2		0.3		0.4		0.5		0.6		0.7		0.8	
	RPM	BHP	RPM	BHP	RPM	BHP	RPM	BHP	RPM	BHP	RPM	BHP	RPM	BHP	RPM	BHP
3000	484	0.51	516	0.6	552	0.7	591	0.82	635	0.95	677	1.07	699	1.1	736	1.18
3200	499	0.62	531	0.7	566	0.8	606	0.92	651	1.06	684	1.15	707	1.18	746	1.28
3400	514	0.73	546	0.81	582	0.91	622	1.03	667	1.17	690	1.22	717	1.29	758	1.4
3600	529	0.84	562	0.93	598	1.03	639	1.15	679	1.28	697	1.31	730	1.4	772	1.52
3800	545	0.96	579	1.05	616	1.15	658	1.28	686	1.37	706	1.41	745	1.53	786	1.65
4000	562	1.09	596	1.18	634	1.29	674	1.41	693	1.46	720	1.54	761	1.67	802	1.79
4200	580	1.23	615	1.31	654	1.42	684	1.52	702	1.57	737	1.69	778	1.82	819	1.94
4400	600	1.37	635	1.45	672	1.56	691	1.62	717	1.72	756	1.86	796	1.98	836	2.09
4600	619	1.51	655	1.59	683	1.68	702	1.76	736	1.89	775	2.02	814	2.13	853	2.24
4800	639	1.65	673	1.73	692	1.81	719	1.93	757	2.08	795	2.19	832	2.3	871	2.4
5000	659	1.78	685	1.87	706	1.97	740	2.12	778	2.26	814	2.37	851	2.46	889	2.56

Air Volume cfm	STATIC PRESSURE EXTERNAL TO UNIT — Inches Water Gauge													
	0.9		1		1.1		1.2		1.3		1.4		1.5	
	RPM	BHP	RPM	BHP	RPM	BHP	RPM	BHP	RPM	BHP	RPM	BHP	RPM	BHP
3000	779	1.29	826	1.42	873	1.56	919	1.7	964	1.84	1009	1.98	1054	2.11
3200	790	1.4	836	1.53	882	1.66	929	1.8	974	1.94	1019	2.07	1063	2.21
3400	802	1.51	847	1.64	893	1.77	938	1.91	983	2.04	1028	2.17	1072	2.31
3600	815	1.64	859	1.76	904	1.89	949	2.03	993	2.16	1037	2.29	1080	2.42
3800	829	1.77	873	1.9	917	2.03	961	2.16	1005	2.29	1048	2.42	1090	2.55
4000	845	1.91	888	2.04	932	2.17	975	2.31	1018	2.43	1060	2.56	1102	2.69
4200	861	2.06	904	2.19	948	2.32	990	2.46	1033	2.59	1074	2.71	1116	2.84
4400	878	2.21	921	2.34	963	2.47	1006	2.6	1048	2.73	1089	2.86	1130	2.98
4600	894	2.36	936	2.49	979	2.61	1021	2.74	1063	2.87	1104	3	1145	3.12
4800	911	2.51	953	2.63	995	2.76	1036	2.88	1078	3.01	1119	3.13	1161	3.26
5000	928	2.67	969	2.78	1011	2.9	1052	3.03	1094	3.15	1135	3.27	1176	3.4

TA 150 BLOWER PERFORMANCE

Air Volume cfm	STATIC PRESSURE EXTERNAL TO UNIT — Inches Water Gauge															
	0.1		0.2		0.3		0.4		0.5		0.6		0.7		0.8	
	RPM	BHP	RPM	BHP	RPM	BHP	RPM	BHP	RPM	BHP	RPM	BHP	RPM	BHP	RPM	BHP
4000	627	1.26	669	1.39	690	1.45	714	1.52	754	1.65	795	1.76	835	1.87	877	1.98
4200	653	1.42	684	1.52	701	1.57	736	1.69	777	1.82	816	1.92	856	2.02	897	2.13
4400	676	1.57	694	1.63	721	1.73	761	1.87	800	1.99	838	2.08	877	2.18	917	2.28
4600	688	1.7	710	1.79	747	1.93	787	2.06	823	2.16	860	2.24	898	2.33	938	2.43
4800	702	1.85	735	1.99	774	2.14	812	2.25	846	2.32	882	2.4	920	2.49	959	2.58
5000	725	2.06	763	2.21	801	2.34	837	2.44	869	2.49	903	2.55	941	2.64	979	2.73
5200	754	2.3	791	2.43	828	2.55	862	2.63	891	2.66	925	2.71	962	2.79	1000	2.88
5400	783	2.53	819	2.65	855	2.75	887	2.82	913	2.82	946	2.86	983	2.95	1021	3.03
5600	810	2.74	845	2.85	881	2.95	912	3.01	935	2.98	967	3.01	1004	3.1	1041	3.19
5800	835	2.95	871	3.05	906	3.15	936	3.19	957	3.14	987	3.16	1024	3.25	1062	3.34
6000	860	3.14	896	3.25	931	3.35	960	3.37	978	3.3	1008	3.31	1045	3.4	1083	3.48

Air Volume cfm	STATIC PRESSURE EXTERNAL TO UNIT — Inches Water Gauge													
	0.9		1		1.1		1.2		1.3		1.4		1.5	
	RPM	BHP	RPM	BHP	RPM	BHP	RPM	BHP	RPM	BHP	RPM	BHP	RPM	BHP
4000	920	2.1	963	2.22	1006	2.34	1048	2.46	1091	2.58	1133	2.69	1174	2.81
4200	939	2.24	982	2.36	1024	2.48	1067	2.59	1109	2.71	1151	2.83	1193	2.95
4400	959	2.39	1001	2.5	1043	2.61	1085	2.73	1127	2.85	1169	2.96	1211	3.08
4600	979	2.53	1020	2.64	1062	2.76	1104	2.87	1146	2.99	1188	3.1	1230	3.22
4800	999	2.68	1040	2.79	1082	2.9	1123	3.01	1165	3.12	1207	3.24	1248	3.35
5000	1019	2.83	1060	2.93	1101	3.04	1142	3.15	1184	3.26	1226	3.38	1267	3.49
5200	1040	2.98	1080	3.08	1121	3.19	1162	3.29	1203	3.41	1245	3.52	1286	3.63
5400	1060	3.13	1100	3.23	1140	3.33	1181	3.44	1222	3.55	1264	3.66	1305	3.77
5600	1080	3.28	1120	3.37	1160	3.48	1201	3.58	1242	3.69	1283	3.8	1324	3.91
5800	1101	3.43	1140	3.52	1180	3.62	1220	3.72	1261	3.83	1302	3.94	1343	4.05
6000	1121	3.57	1160	3.67	1200	3.77	1240	3.87	1280	3.97	1321	4.08	1362	4.19

TA 180 BLOWER PERFORMANCE

Air Volume cfm	STATIC PRESSURE EXTERNAL TO UNIT — Inches Water Gauge															
	0.1		0.2		0.3		0.4		0.5		0.6		0.7		0.8	
	RPM	BHP	RPM	BHP	RPM	BHP	RPM	BHP	RPM	BHP	RPM	BHP	RPM	BHP	RPM	BHP
4800	440	0.78	486	1.16	534	1.46	582	1.7	628	1.9	670	2.07	709	2.18	744	2.24
5000	446	0.88	492	1.25	540	1.54	588	1.77	634	1.97	676	2.14	714	2.26	748	2.34
5200	452	0.98	499	1.34	547	1.62	595	1.84	640	2.04	682	2.22	719	2.34	753	2.43
5400	458	1.08	505	1.43	554	1.7	602	1.92	647	2.12	688	2.3	724	2.44	757	2.54
5600	465	1.18	512	1.52	561	1.77	609	1.99	653	2.2	694	2.39	729	2.53	762	2.65
5800	471	1.28	519	1.61	568	1.85	616	2.07	660	2.28	700	2.48	734	2.64	766	2.77
6000	478	1.38	526	1.7	575	1.93	623	2.15	667	2.37	706	2.58	740	2.76	771	2.91
6200	485	1.48	534	1.79	583	2.01	630	2.23	674	2.46	712	2.69	745	2.88	776	3.05
6400	493	1.59	542	1.88	591	2.1	638	2.32	681	2.56	718	2.81	750	3.01	780	3.2
6600	500	1.69	550	1.96	599	2.18	646	2.41	688	2.67	724	2.93	755	3.16	785	3.36
6800	508	1.79	558	2.05	607	2.27	654	2.51	695	2.78	730	3.07	761	3.32	789	3.54
7000	516	1.89	567	2.15	616	2.36	662	2.61	702	2.91	736	3.22	766	3.49	794	3.73
7200	525	1.99	575	2.24	625	2.46	670	2.73	709	3.05	742	3.38	771	3.68	798	3.94

Air Volume cfm	STATIC PRESSURE EXTERNAL TO UNIT — Inches Water Gauge													
	0.9		1		1.1		1.2		1.3		1.4		1.5	
	RPM	BHP	RPM	BHP	RPM	BHP	RPM	BHP	RPM	BHP	RPM	BHP	RPM	BHP
4800	778	2.33	811	2.47	844	2.69	876	2.94	907	3.18	936	3.38	966	3.58
5000	782	2.43	814	2.59	847	2.81	879	3.07	909	3.32	939	3.53	968	3.75
5200	786	2.54	818	2.71	850	2.95	881	3.22	912	3.48	941	3.7	970	3.93
5400	790	2.66	821	2.85	853	3.09	884	3.37	914	3.64	943	3.88	972	4.12
5600	794	2.79	825	2.99	856	3.24	887	3.54	917	3.82	946	4.07	975	4.33
5800	798	2.93	828	3.14	859	3.41	890	3.71	919	4.01	948	4.28	977	4.56
6000	801	3.07	832	3.3	862	3.58	892	3.9	922	4.22	951	4.51	980	4.81
6200	805	3.23	835	3.47	865	3.77	895	4.11	924	4.44	953	4.75	983	5.07
6400	809	3.4	839	3.65	868	3.97	898	4.32	927	4.68	956	5.01	986	5.35
6600	813	3.58	842	3.85	872	4.18	901	4.56	930	4.93	959	5.28	989	5.65
6800	817	3.77	846	4.06	875	4.41	904	4.8	933	5.2	962	5.58	993	5.97
7000	821	3.98	849	4.29	878	4.66	907	5.07	936	5.49	965	5.89	996	6.31
7200	825	4.21	853	4.53	881	4.92	910	5.35	939	5.79	969	6.22	1000	6.67

TA 240 BLOWER PERFORMANCE

Air Volume cfm	STATIC PRESSURE EXTERNAL TO UNIT — Inches Water Gauge															
	0.1		0.2		0.3		0.4		0.5		0.6		0.7		0.8	
	RPM	BHP	RPM	BHP	RPM	BHP	RPM	BHP	RPM	BHP	RPM	BHP	RPM	BHP	RPM	BHP
6400	535	1.84	583	2.06	630	2.28	674	2.51	713	2.77	746	3.03	776	3.25	805	3.44
6600	545	1.94	593	2.16	640	2.38	683	2.63	720	2.91	753	3.19	782	3.43	810	3.64
6800	555	2.05	604	2.27	650	2.5	692	2.76	728	3.06	759	3.36	787	3.62	815	3.85
7000	566	2.16	614	2.38	660	2.62	701	2.9	736	3.23	766	3.55	793	3.83	820	4.08
7200	577	2.27	625	2.49	671	2.75	710	3.05	743	3.4	772	3.75	799	4.05	825	4.32
7400	588	2.38	637	2.61	681	2.88	719	3.21	751	3.59	778	3.96	804	4.29	829	4.58
7600	600	2.49	648	2.74	691	3.03	727	3.39	758	3.79	784	4.18	809	4.54	834	4.85
7800	613	2.61	660	2.88	701	3.19	735	3.57	764	4	790	4.42	814	4.8	839	5.14
8000	626	2.73	671	3.02	711	3.36	743	3.77	771	4.22	796	4.67	819	5.08	844	5.45
8200	638	2.86	682	3.18	720	3.55	751	3.98	777	4.46	801	4.93	824	5.37	849	5.77
8400	651	3	694	3.35	729	3.75	758	4.21	784	4.7	807	5.21	829	5.68	853	6.12
8600	664	3.15	704	3.53	738	3.96	765	4.44	789	4.97	812	5.5	834	6	858	6.48
8800	676	3.32	714	3.73	746	4.19	772	4.7	795	5.25	817	5.81	839	6.35	863	6.86
9000	688	3.5	724	3.94	754	4.43	778	4.97	800	5.54	822	6.13	844	6.71	868	7.27
9200	700	3.71	733	4.17	761	4.69	784	5.26	806	5.86	826	6.48	848	7.09	873	7.69
9400	711	3.93	742	4.43	768	4.97	790	5.57	811	6.19	831	6.85	853	7.5	878	8.15
9600	721	4.17	750	4.71	775	5.28	796	5.9	816	6.56	836	7.25	858	7.94	884	8.63

Air Volume cfm	STATIC PRESSURE EXTERNAL TO UNIT — Inches Water Gauge													
	0.9		1		1.1		1.2		1.3		1.4		1.5	
	RPM	BHP	RPM	BHP	RPM	BHP	RPM	BHP	RPM	BHP	RPM	BHP	RPM	BHP
6400	833	3.66	863	3.92	892	4.24	922	4.59	952	4.93	981	5.28	1012	5.65
6600	838	3.87	867	4.15	896	4.49	926	4.86	956	5.22	986	5.6	1017	5.99
6800	842	4.09	871	4.39	900	4.75	930	5.14	960	5.54	991	5.94	1022	6.36
7000	847	4.34	875	4.65	905	5.03	934	5.45	964	5.87	996	6.3	1028	6.75
7200	851	4.6	880	4.94	909	5.34	939	5.78	969	6.22	1001	6.68	1034	7.16
7400	856	4.88	884	5.24	913	5.66	943	6.13	974	6.6	1006	7.09	1040	7.6
7600	861	5.18	888	5.56	918	6.01	948	6.5	980	7.01	1012	7.53	1047	8.07
7800	865	5.49	893	5.9	923	6.38	953	6.9	985	7.44	1019	7.99	1054	8.56
8000	870	5.83	898	6.27	928	6.77	959	7.32	991	7.89	1026	8.48	1062	9.08
8200	875	6.19	903	6.65	933	7.19	964	7.77	998	8.37	1033	9	1070	9.63
8400	879	6.56	908	7.07	938	7.63	970	8.25	1004	8.89	1040	9.54	1078	10.2
8600	884	6.96	913	7.5	944	8.1	977	8.75	1011	9.43	1048	10.12	1087	10.81
8800	890	7.39	919	7.96	950	8.6	983	9.29	1019	10	1057	10.73	1096	11.44
9000	895	7.83	924	8.45	956	9.13	991	9.85	1027	10.6	1066	11.36	1105	12.11
9200	900	8.31	931	8.97	963	9.69	998	10.45	1036	11.24	1075	12.03	1115	12.8
9400	906	8.81	937	9.51	970	10.28	1006	11.08	1045	11.91	1085	12.73	1125	13.52
9600	912	9.34	944	10.09	978	10.9	1015	11.75	1054	12.61	1095	13.46	1136	14.28

Repairing or Replacing Cabinet Insulation

⚠ IMPORTANT

DAMAGED INSULATION MUST BE REPAIRED OR REPLACED before the unit is put back into operation. Insulation loses its insulating value when wet, damaged, separated or torn.

⚠ WARNING

This product and/or the indoor unit it is matched with may contain fiberglass wool.

Disturbing the insulation during installation, maintenance, or repair will expose you to fiberglass wool dust. Breathing this may cause lung cancer. (Fiberglass wool is known to the State of California to cause cancer.)

Fiberglass wool may also cause respiratory, skin, and eye irritation.

To reduce exposure to this substance or for further information, consult material safety data sheets available from address shown below, or contact your supervisor.

Lennox Industries Inc.
P.O. Box 799900
Dallas, TX 75379-9900

Mat- or foil-faced insulation is installed in indoor equipment to provide a barrier between outside air conditions (surrounding ambient temperature and humidity) and the varying conditions inside the unit. If the insulation barrier is damaged (wet, ripped, torn or separated from the cabinet

walls), the surrounding ambient air will affect the inside surface temperature of the cabinet. The temperature/humidity difference between the inside and outside of the cabinet can cause condensation on the inside or outside of the cabinet which leads to sheet metal corrosion and subsequently, component failure.

REPAIRING DAMAGED INSULATION

Areas of condensation on the cabinet surface are an indication that the insulation is in need of repair.

If the insulation in need of repair is otherwise in good condition, the insulation should be cut in an X pattern, peeled open, glued with an appropriate all-purpose glue and placed back against the cabinet surface, being careful to not overly compress the insulation so the insulation can retain its original thickness. If such repair is not possible, replace the insulation. If using foil-faced insulation, any cut, tear, or separations in the insulation surface must be taped with a similar foil-faced tape.

Optional Accessories

Refer to the *Lennox TAA Series Engineering Handbook* for the latest available accessories for this unit.

- Float Switch Kit
- Freeze Stat Kit
- Return Air Grill Kit
- Economizer Kit
- UVC Germicidal Light Kit
- Air Filter Kit
- Hot Water Coil Heating Kit
- Electric Heat Kit
- Steam Coil Heating Kit